

***Building and Testing the
John Bedini Monopole
Mechanical Oscillator
Energizer with Simplified
Schoolgirl Circuit (SSG).***

“Everybody should have this knowledge so they can get energy for themselves. Energy shouldn’t be controlled.” – John Bedini

US Patent 6,454,444 Protected

Table of Contents

	Page
Introduction	4
Summary Statement	4
What I Understand the Monopole SSG To Be	4
Mental Preparation Necessary to Learn	4
Twofold Purpose of this Experiment	4
The Quest for Free Energy or Over Unity	4
Disclaimer	6
Bedini Monopole 3 Group Policy and Structure	7
Commitment to the Policy	7
Related Groups	7
Structure	7
Home	7
Messages	7
Files	8
Photos	8
Links	8
Database	8
Polls	8
Overview	9
Safety First	9
Assemble and Test Basic Unit	9
Tuning	9
Measure Output Current to Charging Battery	10
COP Testing	10
Table 1: SSG COP Calculator	11
Selecting a Lead-Acid Battery for Testing	12
The Charging Process	12
The Discharge Process	12
Selecting Charge/Discharge Criteria	12
Parts and Materials List	14
Parts and Materials	14
Tools Required	16
Detailed Construction Instructions	17
Tuning Instructions	18
Basic Tuning Instructions	18
1-Ohm Resistor Test	18

Bedini Monopole 3 Group Experiment

Detailed Testing Procedure	20
Measuring the “conventional” current into the charging battery	20
First method	20
Second Method	20
Selecting a battery and a testing schedule for the COP testing	21
The discharge cycle	21
The charge cycle	21
Further Testing	22
Invitation to the Advanced Groups	23
Resources for history, theory, and advancement	23
Conclusion	24

Bedini Monopole 3 Group Experiment

Introduction

Summary Statement:

Welcome to the Bedini_Monopole3 group! This document contains all the information needed for building and testing the Bedini Monopole Mechanical Oscillator Energizer with Simplified Schoolgirl Circuit (Monopole SSG, for short). It also provides additional references to related theory and advancement beyond this starting point.

Included are the policies of the Bedini_Monopole3 group, the purpose of this group experiment and how to build and test the Monopole SSG. Thus organized, it may not take the new student more than a day to learn the essential details and build as directed.

We recommend that the beginner reads this manually thoroughly before starting to build.

What I Understand the Monopole SSG to Be:

The Monopole SSG is not a conventional motor, but primarily a mechanical oscillator that triggers a signal so that a battery bank will become charged. No conventional systems charge batteries in this unique and fundamentally different way. This unconventional signal, in relation to the battery, is the key to understanding the system.

“We are surrounded by an electrical gas which we can tap, if we know how to utilize it.” – John Bedini

Mental Preparation Necessary to Learn:

As such, the learning process starts when one refrains from assuming a conventional energy transfer from the primary source (battery), driving the motor, thereby pushing electron current into the charging bank. Only an insignificant amount of conventional charging could take place with the arrangement in the schematic (circuit diagram). Therefore the student must let go of previous theories, avoid urges to change the system to charge in an accustomed manner, and examine the phenomenon as it actually appears.

“I made the Monopole very simple to show that what makes it work isn't electron current.” – John Bedini

Twofold Purpose of this Experiment:

The first purpose is to observe a different kind of charging, fundamentally opposite from conventional systems. Only after we notice two different kinds of energies involved in the process can we carefully distinguish and manipulate them for practical advantages in powering various loads. The second purpose is to investigate some of the advantages in this charging method over conventional methods.

“We pulse the coil to make it nonlinear. This opens the Bloch Wall – the place in the center of the magnet where the energy comes from. Opening and closing the window pumps in zero-point energy.” - John Bedini

The Quest for Free Energy or Over Unity:

Most researchers here want free electrical energy. When this desire takes the form of a blinding passion, it hinders proper scientific research and prevents one from learning how to get it. You will not discover free energy while gripped by a fierce desire to rush and bypass procedure. Only when the two purposes of this experiment are personally realized will the researcher understand what this technology offers in

Bedini Monopole 3 Group Experiment

relation to free energy.

This is why we emphasize following instructions and progressing naturally. Do not begin by attempting to charge one battery faster than the primary battery discharges, as most want to do right away. First we must know that our machines are built right and then get a feel for how they work. Then we must learn how batteries work in general and how they relate to this system. This requires time to cycle at least one battery through a charging and loading scheme many times to learn how it responds.

None of this is hard to do, but it takes patience, not blind passion. John Bedini has always said there is no truly "free" energy, as you have to work in several ways to gather and use it. Our first discovery of Over Unity may come unexpectedly. Instead of looking at the battery that powers the system, we look at the charging battery and measure its inputs and outputs over the charge and discharge cycle. When the machine is properly built and tuned, by measuring with conventional meters we will see more energy leaving the receiving battery via a constant load than entered it.

By the time this is realized, the student will also appreciate some of the other benefits of this kind of charging as compared with other chargers. The student who has observed Over Unity in the charging battery can then conclude that something else is charging the battery and will naturally progress onward in this research. Only those who are known for following directions and contributing to this research will be considered for invitation to other advanced groups.

Bedini Monopole 3 Group Experiment

Disclaimer

The group owner, the moderators, John Bedini and company, and any and all affiliated persons and entities, are in no way responsible for what is said on this group unless they say it themselves.

This forum is for educational purposes only. No information is to be used to violate any civil laws. No reader is permitted to infringe on registered patents or copyrighted materials. You do not have permission to sell this information or quote it contrary to copyright laws. By joining this forum, you signify your agreement with all of the foregoing terms and conditions.

Bedini Monopole 3 Group Experiment

Bedini Monopole 3 Group Policy and Structure

Commitment to the Policy:

The simple policy in this group experiment is to build as directed before changing anything, in accordance with the true scientific method.

There is a great temptation to use different parts because they are on hand, or to try and improve upon the system. If gratified, these temptations will result in frustration and wasting of time. For this research to progress, members are asked to commit to one simple directive: follow the instructions politely.

Do not assume you are entitled to receive personal instruction or other free gifts from others; such demands are out of place. All diversions from the simple purpose, no matter how useful or interesting, are outside the scope of this focused experiment. In the interest of educating as many people as possible without undue demands on the volunteer moderators, please rely on the public information sources that have been provided.

Occasionally the moderators may recommend some relevant information to encourage members and show what may lie ahead in this research. The membership list has become so large that we must all remain on topic to meet our learning/teaching objectives.

Related Groups

Related topics may be freely discussed without moderation on the companion forum:

<http://tech.groups.yahoo.com/group/Monopolemotor/>

Other related Yahoo! Groups:

http://tech.groups.yahoo.com/group/Bedini_Monopole2/ - intermediate, by invitation, private

http://tech.groups.yahoo.com/group/Bedini_Monopole/ - most advanced, private

http://tech.groups.yahoo.com/group/Bedini_sg3/ - newsletter, info

http://tech.groups.yahoo.com/group/Bedini_window_energizer/ - advanced, members only

Other related web sites:

<http://energenx.com> - Energenx Inc. - John Bedini's company

<http://r-charge.com> - Renaissance Charge LLC - Rick Friedrich's company, selling Energenx technology

<http://cheniere.org> - The Tom Bearden website, offering information, books and DVDs on the topic

<http://energyfromthevacuum.org> - Documentary DVDs

Structure

- [Home](#)

This is the Bedini_Monopole3 group homepage. It displays group activity within the last 7 days, the group's description message, the group experiment schematic, most recent messages (where search functions can be performed) and a message history table.

Along the left hand side of the screen are the links to the functional areas, which are described below.

- [Messages](#)

This is the section of the group where members may post new messages and respond to

Bedini Monopole 3 Group Experiment

previously posted messages. Members may only post messages in accordance with the group policy. Messages not conforming to the group policy will be rejected. Members that attempt to post spam to the group will be banned and their membership revoked without warning.

The Messages section also contains both basic and advanced search methods, which members are encouraged to use prior to posting any new questions.

All messages are moderated and will not appear until approved.

- [Files](#)

The Files section contains miscellaneous files that are helpful to the experimenter, such as instructions and parts information. There is also a folder called "[Experimenter's File Section](#)" where experimenters are encouraged to create their own folder to post their build descriptions and test results. PDF (Portable Document Format) files are preferred and there is a link to a [free PDF file converter](#) in the Links section.

It is the member's responsibility to ensure all files are checked for viruses, trojans, etc. before uploading or downloading files.

The moderators will delete any files that are not relevant to the group experiment.

- [Photos](#)

This section is available to members to upload photos of their replications to share with other members. Photos of other related subjects are allowed.

All photos must be approved by the moderators before they are visible to the members. Unrelated photos will be deleted by the moderators.

- [Links](#)

The Links section provides an area where members may post links to other web sites that are relevant to the group experiment. Mostly, links are used to advise members where to purchase the recommended parts for your projects or to aid in building the Monopole SSG.

Unrelated links will be deleted by the moderators and the moderators may ban members for non-compliance.

- [Database](#)

This section is used to record database type information, such as [FAQ](#) (Frequently Asked Questions) where members should check before posting messages, or [Summary of Group Experiments](#). Members are encouraged to record their Monopole SSG build information in this database.

- [Polls](#)

Members are encouraged to vote on existing polls or create their own polls. Please contact one of the moderators privately beforehand if you wish to create a poll.

Bedini Monopole 3 Group Experiment

Overview

Bedini Monopole 3 group members can meet the group's learning goals by building and testing a Bedini Monopole SSG according to the circuit shown here.

- What is charging the battery?
- What does the amp meter indicate is going into the battery?
- What do we get out of the battery on a repeated basis?

Do as many presentations as you wish to help in this group experiment.

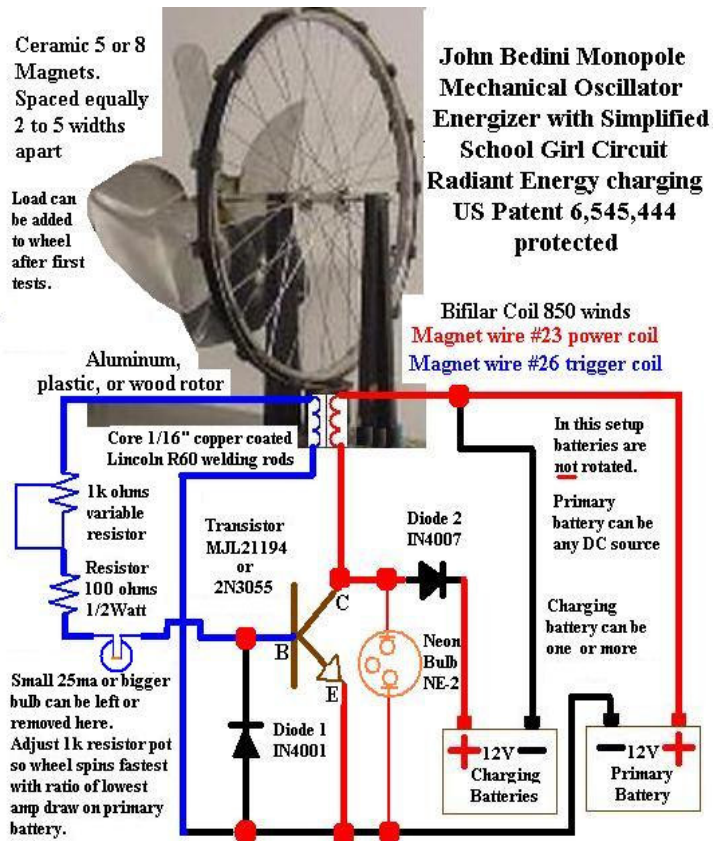

Safety First

Flying magnets are dangerous. Wrap fiberglass filament tape around the circumference of your wheel to restrain the magnets. This safety measure is in addition to regular gluing of the magnets.

Lead-acid batteries contain a diluted sulphuric acid electrolyte, which is a highly corrosive and poisonous.

When working with batteries, wear safety goggles, protective clothing and have plenty of ventilation, remove any jewelry, and exercise caution.

Wash you hands after contact with batteries. Neutralize spilled acid with baking soda.

Assemble and Test Basic Unit

After you have obtained your parts from either the kit or sources indicated in the parts list, construct the basic Monopole SSG.

Connect the batteries and verify the Monopole SSG runs.

See the [Messages](#) area for Troubleshooting information.

Tuning

Tune for the highest wheel speed for lowest supply battery draw current. This is reported in Magnets per Minute per milliamp of supply battery draw current (Mpm/mA).

Testing to see if the Monopole SSG is tuned can also be done using the 1Ω resistor test as detailed in the "Tuning" section on page 18.

Bedini Monopole 3 Group Experiment

Measure Output Current to Charging Battery

The best way is to use an **analog** current meter in series with the charge battery. If you use a digital current meter, average the readings.

Do not leave the current meter permanently connected as it reduces charge rate.

COP Testing

Batteries do not charge or discharge exactly as most people expect. Repeated load testing helps you understand the complexities of batteries. The best way to measure how much energy a battery has is to measure how much work it can do via a load test.

The Battery's Coefficient of Performance (COP) is calculated from these load tests. Tabulate data for each charging/discharge test as shown in the example below. A working version of this calculator can be found [here](#).

Coefficient of Performance (COP) is defined as "total energy performed as work / total energy paid for by the operator". It is expressed as a decimal figure, where 1.00 means energy output equals energy input.

Bedini Monopole 3 Group Experiment

Selecting a Lead-Acid Battery for Testing

The size and condition of the battery you use will affect the times required for charging and discharging cycles.

For the Monopole SSG to be most effective, the battery must be conditioned for about 5 to 10 charge/discharge cycles, or until the load times begin to stabilize. Older batteries go through a de-sulfating process at first which will take a longer time to condition, thus a brand new battery is recommended.

Further conditioning of the battery will continue to take place the more the battery is cycled.

For quicker results, select a 3 to 7 amp hour (Ah) battery.

For a battery rated in cold cranking amperes (CCA) see the manufacturer's website or contact the manufacturer to obtain the equivalent rating in Ah.

Lead-Acid batteries are recommended and come in Sealed Lead-Acid (SLA), Valve Regulated Lead-Acid (VRLA), deep cycle, flooded and many other constructions. We recommend flooded deep cycle construction as it gives better results.

Ni-cad, Lithium Ion, Carbon, Alkaline and non-rechargeable batteries are not recommended.

The Charging Process

The charging process is usually stopped after a predetermined voltage is reached or a fixed amount of time. See "**Selecting Charge/Discharge Criteria**" section for determining terminal voltage and/or time duration to use.

The Discharge Process

For best long-term results it is recommended to rest the battery a minimum of one hour before charging or discharging. However, in the short term it is fine to cycle the battery without a rest period.

Lead-acid batteries are rated for a 20-hour discharge. The current that will discharge the battery from fully charged (about 12.65 volts) to fully discharged (about 12.0 volts) in 20 hours is called the C20 rate. See this [graph](#) for more details.

Discharge rates higher than C20 reduce the life of a lead-acid battery. This is not as true for deep cycle batteries, however discharging at a higher rate than the C20 rate may reduce the life of the battery.

Discharging is done with a resistor or load of adequate power rating. It is stopped after a predetermined low voltage limit is reached. Use 12.2 volts or a value determined by the criteria in the next section.

Discharge times are tabulated in a spreadsheet similar to Table 1.

Selecting Charge/Discharge Criteria

Depth of Discharge (DOD) is the percentage of the battery capacity used. For maximum battery life DOD values should be a minimum of 10% and a maximum of 50%. 10% DOD of a 10 amp hour (Ah) battery used at the C20 rate requires 2 hours. 50% DOD requires 10 hours. See this [table](#) for common C20 rates.

The maximum discharge load value is calculated by 12.2 volts divided by discharge current. For a 10Ah battery discharged at the C20 rate (0.5 A) use a 24.4 ohm resistor or similar load. The minimum power rating of this resistor is 12.2 volts x discharge current (0.5 A) or 6.1 watts.

A State of Charge (SOC) table for your particular battery is required to determine what terminal voltage to use. Many variables such as temperature and battery construction affect the open circuit or "standing"

Bedini Monopole 3 Group Experiment

voltage measured with a digital voltmeter. Typical values for a flooded cell battery at 80 degrees F (26.7 C) are: 100% - 12.65v, 75% - 12.45v, 50% - 12.24v, 25% - 12.06v and 0% - 11.89. See this [table](#) for more details.

These open circuit or “standing” (i.e. nothing connected to the battery) values are not terminal voltages used for discharge limits. Do a trial discharge to some value such as 12.5 volts. Disconnect the discharge load. Measure the open circuit voltage of the battery after a few minutes. Use this voltage and a SOC table for your battery to determine how much battery capacity you have left.

Choosing a modest battery size and a lower DOD value makes the testing take less time.

Bedini Monopole 3 Group Experiment

Parts and Materials List

The following is the list of parts and materials required to replicate the Bedini Monopole SSG as presented in this manual.

You can also order parts for the Monopole SSG at the following website: <http://rpmgt.org/order.html>

For other sources of parts, refer to the [Links](#) section.

Parts, listed alphabetically.

BE SURE TO GET EXTRA OF EVERYTHING. YOU WILL PROBABLY NEED IT.

Alligator Clip Leads

Purpose - To connect batteries to circuit.

Specifications - Wires need to be larger than AWG#20, clips need to be rated for at least 5 Amps. At least 12" recommended. Ensure clips are soldered to wires to ensure proper connection.

Tolerance - Wide range, with the above minimums in mind, especially the wire and clip ratings.

Quantity - At least four. A dozen recommended for experimental variations (e.g. hooking up output batteries in parallel).

Batteries (Rechargeable) – see “**Selecting a Lead-Acid Battery for Testing**” section for details.

Bicycle Wheel Rim - Or Other Rotor Device

Non-magnetic wheel rim, steel shaft and spokes are OK. Other rotor devices have been used successfully: E.g. CD ROM drive mechanism, HDD platter, target board, child's bike wheel (plastic). Use your imagination.

Coil Core

Purpose – To create an electromagnet by applying current to the coil windings.

Specifications - Welding rod, 1/16" inch (1.6mm) diameter copper coated soft steel rod. 3' (750mm) lengths. Rods will be cut to length of the coil spool. Lincoln R60 works best but many others will work just fine.

Quantity – Get 3-5 lbs. (1-2kgs) (around 10 rods of 3 feet each).

Tolerances - Rough cut okay. Diameter not crucial - could be smaller by 50% or larger by 100%.

Consideration - The thicker the rod, the harder it is to cut. You're going to be cutting a lot to fill the spool hole. (around 50-100)

Coil Spool

Purpose - To wind the parallel lengths of magnet wire around to (1) create an electromagnet to pump the magnets on the wheel and (2) receive pulses of energy from the magnets for the charging battery.

Specifications - Plastic, 3" (75mm) diameter by 3" (75mm) long, with 3/4" (18mm) center opening.

Quantity - One

Tolerance - Opening can be +/- 20%. Length of spool can be +/- 40%. Material needs to be non-metallic, non-magnetic, and adequately sturdy.

Diode (D1)

Purpose – Transistor's Base to Emitter flyback diode

Specifications - 1N4001, 1A, 50V. (may use 1N914)

Parameters - Low power, fast silicon diode

Diode (D2)

Purpose – Output diode to charging battery

Specifications – 1N4007, 1A, 1000V (may use 1N5408)

Parameters - Low power, fast silicon diode

Bedini Monopole 3 Group Experiment

Heat Sink

Purpose – To keep transistor cool in case it gets warm.

Specification – Small piece of aluminum slightly larger than the transistor, or a suitable commercially available heat sink.

Quantity - One

Hookup Wire

Purpose – To connect all the components together.

Specifications – AWG#20 or similar, insulated.

Quantity – At least 3' (90cm).

Grain of Wheat Bulb (optional)

Purpose – To “servo” the current going to the Base of the transistor.

Specifications – 12V, 25mA (as commonly used in dolls houses)

Quantity – One, a few extra if you burn one up.

Magnet Wire

Purpose – To wind around coil spool. Both wires are wound together “bifilar” on the coil spool.

Specifications – Trigger wire: AWG#26 (0.40mm), Power wire: AWG#23 (0.56mm)

Tolerance – Trigger wire: no smaller than AWG#26, no bigger than AWG#21.

Power wire: no smaller than AWG#23, no bigger than AWG#18.

Make sure that each wire does not differ more than 3 gauges apart.

Quantity - One length of each wire, about 100'-150' (30m-45m)

Magnets

Purpose – To attach to the outside of the rotor, in order to maintain rotation and provide an induced voltage on the trigger wire to fire the transistor.

Specifications - Ceramic grade 5 or 8; dimensions: 1" x 2" x 3/8" inches. (25mm x 50mm x 18mm)

Quantity - 16 for a 24-inch wheel. Get some extra in case of breakage. You also might consider one or two for a control, to measure Gauss before and after experimental runs.

Tolerance - Must be ceramic (strontium ferrite). Can be +/- 20% in size. Number of magnets is not essential, though an even number and even spacing will be necessary if you wish to try and add more coil/circuits later. Neodymium magnets are NOT suitable for the Monopole SSG!

Neon Lamp

Purpose - The lamp provides a path for the output energy in case the receiving battery is disconnected while the motor is running. This prevents burn-out of the transistor. The light should not go on unless the output battery is disconnected.

Specifications - NE-2, 90V DC neon bulb.

Quantity - One

Resistor (R1)

Purpose – A minimum Base resistance for the transistor.

Specifications – 100 ohms, ½ watt.

Quantity – One

Resistor (Potentiometer)

Purpose - Varying the resistance to the base resistor to be able to tune the Monopole SSG.

Specifications – 1K ohms, 2 watt.

Tolerance – 1K ohms to 20K ohms, 1-2 watt. Smaller values allow for easier tuning.

Quantity - One, although once the Monopole SSG is tuned you should replace the potentiometer with a fixed value resistor of the same resistance.

Bedini Monopole 3 Group Experiment

Super Glue

Purpose – To attach the magnets to the rotor.

Quantity – A small tube or bottle.

Alternatives – 2 part epoxy, any thing that bonds well.

Tape

Purpose - For second level of adhesion of magnets to rotor (beyond just glue). Also to maintain wires to prevent snagging.

Specifications - One-sided, preferably nylon “strapping” tape, electric tape or duct tape.

Tolerances - Any tape that is adequately sticky and non-magnetic.

Quantity - Enough for the circumference of your wheel plus a little for overlap and do-over.

Transistor

Purpose – To switch the current through the coil, this in turn charges the secondary battery.

Specifications - 2N3055, 100V, TO-3 case; fully metal (may use MJL21194)

Quantity – One. Several extra in case you burn one up.

Wood (Stand)

Purpose - To hold the wheel steady, and to fasten the circuit and hold the coil.

Specifications - Plywood or solid wood, may use acrylic sheet. Anything non-magnetic is fine.

Quantity - One sheet approximately 3' x 2' feet (90cm x 60cm) square by ~3/4" inch (18mm) thick (to be cut into three pieces -- two for uprights and one for base).

Two lengths of 2" x 6" (50mm x 150mm) or larger of about 6" (150mm) long (to hold coil and stabilize uprights)

Tolerance - Any non-magnetic material of size and thickness adequate to hold the rotor.

Tools Needed

- Wire cutter.
- Analogue DC panel ammeter, rated to 5 amps. (may use smaller, but rated at least at 1 amp)
- Digital or analogue DC volt meter, rated to 20VDC.
- Digital or analogue ohm meter.
- Suitable wrench to attach rotor to stand.
- Something to cut the welding rods to length – heavy duty wire cutter, hacksaw, etc. (may want to use cutter available where you purchased the rods).
- Something to fabricate the stand for the rotor and coil. (E.g. jig saw to cut wood).
- Soldering gun and solder.
- Needle nose pliers, to hold components whilst soldering.
- Metal drill to put hole in aluminum heat sink to fasten circuit to device.
- Screw driver and 2-4 screws to screw heat sink to stand.
- Screws or glue to assemble stand.
- Drill, to wind wires on coil. (Optional)
- Bike computer or tachometer to measure speed of rotor (Optional).
- Stopwatch, wristwatch or clock for timing charge and discharge cycles.
- Compass, to determine North and South poles of magnets.

Bedini Monopole 3 Group Experiment

Detailed Construction Instructions

All right, now that we have all the parts we need and the tools to put it together it's time for the fun stuff – building the Monopole SSG!

Here are the steps you need to follow:

1. Work out how many magnets you will attach to the rotor. As a general rule of thumb, the magnets should be spaced 2-5 magnet widths apart. You can also use "[Gords Bedini SSG.xls](#)" calculator in the Files section to calculate this.
2. Mark out on the rotor where the magnets will go. Note: the magnets are placed on the rotor so that when the magnets go past the coil the width of the magnet passes over, NOT the length. Look at the picture on the [schematic](#) for details.
3. Attach the magnets (all North poles facing out) with glue and strap with tape. Use your compass to determine which side of the magnet is North.
4. Mount the rotor to the frame, ensure that the rotor spins freely. If necessary re-lube the bearings with a small amount of Excel plus lubricant.
5. Wind your coil with the magnet wire as per "[BifilarCoilConstruction.jpg](#)" in the Files section. 850 winds are recommended. Leave approximately 12" (30cm) of wire at the start and end of the coil for attaching to the circuit.
6. Fill the coil spool with the welding rods cut to the length of spool. The rods may extend out of spool up to 1/2" (12mm). Super glue the rods into the core when completed, to stop the magnets on the rotor "sucking" them out.
7. Mount the coil underneath the rotor, leaving approximately 1/8" (6mm) gap between the top of the coil and the magnets.
8. Build the circuit as per the schematic "[Schematic.JPG](#)" in the Files section.
9. Give the rotor a "free" spin before connecting the batteries.
10. Ensure all connections are secure and double check all the circuit connections.

Bedini Monopole 3 Group Experiment

Tuning Instructions

Once you have built the Monopole SSG, it needs to be tuned to its “sweet spot”. The “sweet spot” is defined as the highest rotor RPM for the lowest current draw on the primary battery. Now, this does not mean that you just adjust the potentiometer for the highest RPM, nor does it mean that you adjust it for the lowest current draw. You want a balance in between the two. After following the Basic Tuning Instructions below, you may wish to check this with the 1Ω resistor test.

Basic Tuning Instructions

1. Set the potentiometer to its highest resistance value (or around 1000 ohms if using a larger potentiometer).
2. Connect the secondary (charging) battery as per the [schematic](#).
3. Connect the analogue DC panel ammeter in series with the negative terminal of the primary (source) battery. You may also use a mains powered 12VDC power supply in place of a battery. If so, use one that is rated at least 3 amps.
4. Connect the primary (source) battery as per the schematic. You may hear a high pitched squeal coming from the coil. This is normal. Give the rotor a spin by hand to start the Monopole SSG.
5. If the rotor does not sustain rotation, decrease the resistance by adjusting the potentiometer.
6. Wait until the rotor speed stabilizes. (about 1 minute) You may see the ammeter fluctuate while the rotor is coming up to speed. This is also normal.
7. Slowly adjust the potentiometer, a little bit at a time, until you get the highest RPM for the minimum current drawn from the primary battery. If the potentiometer gets hot back off a little or it will burn out.
8. Wait for rotor speed to stabilize after making potentiometer adjustments (around 1-2 minutes).
9. Once you have tuned the Monopole SSG to its “sweet spot”, stop the Monopole SSG by disconnecting the primary battery.
10. Restart the Monopole SSG and see if the Monopole SSG maintains it’s “sweet spot” when restarted.
11. Replace the potentiometer with a fixed value resistor. Potentiometers have a tendency to fluctuate their resistance. Measure the resistance of the potentiometer and replace it with a fixed value resistor, or a combination of resistors of the same resistance value as the potentiometer.

Bedini Monopole 3 Group Experiment

1-ohm Resistor Test Procedure

Measure exact resistance of 1-ohm resistor before testing. It might be a little more or less than 1 ohm.

Place a volt meter over the 1-ohm resistor. If the meter reads less than 1 volt, the test passed.

If the meter reads more than one volt or the resistor gets hot the test failed. Re-tune the SSG.



**John Bedini Monopole
Mechanical Oscillator
Energizer with Simplified
School Girl Circuit
Radiant Energy charging
US Patent 6,545,444
protected**

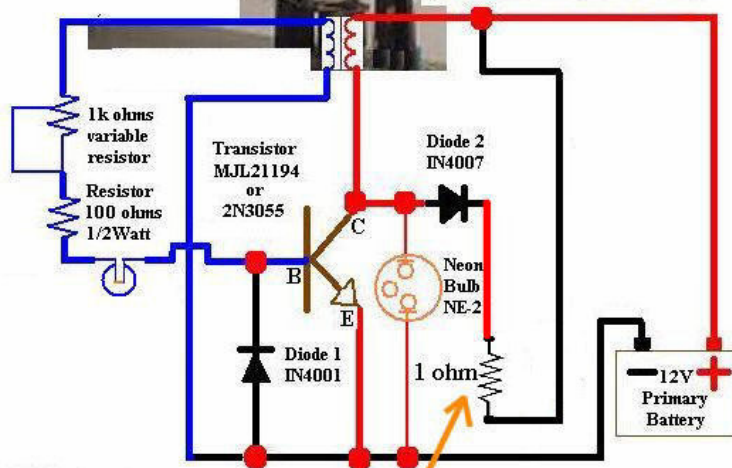

**1-ohm resistor here
in place of charging battery**

ML Stockton
12 November 2007
(updated 2 July 2008 by John K.)

1. Turn off the Monopole SSG, by disconnecting the primary battery.
2. Disconnect the charging battery. The charging battery is not connected to the Monopole SSG during the 1Ω resistor test.
3. Measure the exact ohms of the resistor. It may be a little more or less than 1Ω.
4. Connect the 1Ω resistor between the + and - terminals where the charging battery had been.
5. Turn on the Monopole SSG. Let it come up to speed.
6. If the neon bulb in the Monopole SSG circuit comes on, or if the 1Ω resistor is gets hot, then turn the Monopole SSG off immediately.
7. Use a voltmeter to measure voltage across the 1Ω resistance. This should be 1 volt or less, and the resistor should not get hot.
8. If the voltage is higher than 1 volt, or the resistor gets hot, then adjust the base resistance potentiometer. In this case you probably need to INCREASE the base resistance to reduce the voltage on the 1Ω test resistor.

Bedini Monopole 3 Group Experiment

The 1Ω resistor test is used to confirm that the Monopole SSG is tuned. It also helps us see that there are two kinds of energy going to the charging battery. The "conventional" kind of energy is not enough to account for the observed charging.

Therefore there must be something else happening that is hard to measure with our conventional instruments.

Note: If you have changed the size of the primary or secondary batteries, it may be necessary to re-tune the Monopole SSG.

Bedini Monopole 3 Group Experiment

Detailed Testing Procedure

The purpose of this test is to help you understand the two different types of energy that are found with the Monopole SSG. The first type is the conventional "Classical Electromagnetic" (CEM) energy that is taught in all the textbooks.

The second type of energy is what we call "Radiant Energy" (RE) or "Energy from the Vacuum" (EFTV). None of this type of energy can be found in the textbooks we have today, although it has been around long before text books!

What we are looking for is to bring out a phenomenon where we can extract more "conventional" energy out of the charging battery than the "conventional" energy we put into the charging battery. Bringing out this phenomenon is undeniable proof that "something" else is charging your battery.

Measuring the "conventional" current into the charging battery

Now that we have tuned the Monopole SSG to its "sweet spot", the next step is to measure the "conventional" current going into the output battery. At this point we will not be concerned with the current being used by the input battery. This will come into play later, so for now, as hard as it is, just try and forget it.

This circuit uses pulsed DC current, which is a little trickier than normal to measure. Try to measure it with at least two different methods until the two agree with each other. Here are the two easiest methods we have found to measure the conventional energy into the charging battery.

First method.

1. Place your analog amp meter in series with the positive terminal of the charging battery.
2. Start the Monopole SSG and wait until it comes up to speed.
3. Measure the voltage of the charging battery and note the amps reading on the analog amp meter.
4. Multiply the amps and the voltage together to get the watts.
5. Remove your analog amp meter before the start of the charge cycle.

Second Method.

1. Get 2 identical small flashlight bulbs (12v 100ma for example).
2. Replace the charging battery with one of the light bulbs.
3. Take the other light bulb and put it in series with a potentiometer and an amp meter.
4. Connect it in series with the same battery you are running the motor on.
5. Run the Monopole SSG.
6. Adjust the potentiometer until both light bulbs glow at the same brilliance. Then read the amp meter.
7. Put a voltmeter across the light bulb. Multiply the volts by the amps to get the watts.

Bedini Monopole 3 Group Experiment

Selecting a battery and a testing schedule for the COP testing.

Before starting the charge and discharge cycles for the COP testing it is a good idea to figure out what your testing schedule will be. You need to consider the size of your charging battery, which relates to how long it will take to charge, the size of the load and the time you have available to collect data.

Firstly, choose a battery size that will be easy to work with, keeping within the C20 rates for both charging and discharging. You don't want to pick a battery too small that heats up when being charged and you don't want a battery that is too large that it takes too long to charge. Generally, a battery rated between 3Ah and 7Ah will work well. Stick to 12V batteries for now. Try and use brand new batteries as older batteries will take more time to yield the best results. Save those old junk car starter batteries for later.

Next, find a load that will discharge your battery within the C20 rate. Fixed resistors work best, but you can choose anything where the load is constant. Auto bulbs and 12V DC fans also work well. Use your imagination. Laptop computers do not work well as the load can vary from time to time.

Next, figure out how much time you have to collect data. E.g. If you work during the day and want to sleep at night, choose a cycle that allows you enough time to charge and discharge.

For example, you could charge during the day and discharge through the night. Your schedule may also determine the size of the load you can use. I.e. you'll want to be there when the discharge cycle ends so the battery does not go under a certain voltage.

If you don't have time to do a charge or discharge cycle in the above example, you could pick a larger battery and smaller load than C20 so you could do a 24 hour charge and 24 hour discharge cycle. Sticking to the same cycle times will show trends better than if you were to vary the cycle times.

The discharge cycle

1. Before connecting the load to your battery, measure the voltage of the battery and write it down as the "Start Resting Voltage" in the Output Joules section of the ["SSG COP Calculator"](#) table.
2. Connect an amp meter (analog or digital) in series with the discharge load and connect the load. Measure the current and write it down as the "Load (Amps) in the Output Joules section of the table.
3. Start your stopwatch or write down the time you started the discharge.
4. Stop discharging before the voltage of the battery gets too low and starts damaging the battery. This voltage should be no lower than ~12.0V when loaded. Record the discharge time, in seconds, in the "Time (Seconds)" field of the Output Joules section of the table.
5. Wait a few minutes for the battery voltage to stabilize again. The battery voltage will bounce back up slowly after the load is released.
6. Record the voltage of the battery after it has rested in the "End Resting Voltage" field in the Output Joules section in the table. The table will calculate the Average Voltage, Load (Watts) and Output Joules.

The charge cycle

1. Before connecting the charge battery to the Monopole SSG, measure the voltage of the battery and write it down as the "Start Resting Voltage" in the Input Joules section of the ["SSG COP Calculator"](#) table.
2. Write down the "Input (Amps)" and "Input (Watts) figures that you obtained from the ["Measuring the "conventional" current into the charging battery"](#) process.
3. Connect the charging battery to the Monopole SSG and then connect the primary source battery (or power supply). Start the Monopole SSG.
4. Start your stopwatch or write down the time you started the charge cycle.
5. Stop charging before the voltage of the battery gets too high and starts damaging the battery. This voltage should be somewhere in between 13.0 and 15.0V when charging. Record the

Bedini Monopole 3 Group Experiment

- charging time, in seconds, in the "Time (Seconds)" field of the Input Joules section of the table.
6. Wait a few minutes for the battery voltage to stabilize again. The battery voltage will drop down slowly after the charging is finished.
 7. Record the voltage of the battery after it has rested in the "End Resting Voltage" field in the Input Joules section in the table. The table will calculate the Average Voltage, Load (Watts) and Input Joules.
 8. The table will also calculate the COP of the charging battery.

Note: The COP of the charging battery may not be as you expected, or >1.00 straight away. Most batteries, even when new start sulphating straight away as soon as they leave the factory. Some brands of batteries are better than others. However, repeated charge and discharge cycles should improve the COP figure. Do at least 10-15 cycles. You can do as many cycles as you can.

Record all of your results and post them in a folder you have created in the Files section, in the [Experimenter's Files Section](#). Do not worry if your numbers aren't as good as others, all data is considered important.

Further Testing

If you wish, you can do some load comparison testing with a battery that has been charged with a conventional battery charger.

What we want is to take two new batteries off the shelf with the same date stamp and being equal in all respects. Using the same test load for each, discharge the battery down to ~12.2v at the C20 rate. You only need to record the load times after each charging cycle. One battery is charged with the Bedini Monopole SSG, and the other with any conventional charger. You want to see if the load time increases or decreases with either charger used. You know already that the conventional charger with repeated load tests will result in less and less load time until the battery has no more capacity to be charged and power a load. But what about the Bedini Monopole SSG?

You want to charge these batteries up with either charger over an 8 to 24 hour period. Use between 3 and 7Ah batteries, lead acid for now (too big batteries will take too long to charge, so those \$20 lawnmower batteries are fine). Do not worry if one charger takes longer than the other. We are not presently concerned with how long it takes to charge, or even what amount of energy is consumed on the front end (you can use a 12v battery and/or 12v DC power source on the front end). Just try and get the charging batteries fully charged (and keep the primary battery charged as well), as in 13.5 to 14V (showing while still charging, or around 13V while soon disconnected from either charger). Let them settle a little after charging or discharging, but load them ASAP after that. If you use big batteries, and/or big deep cells, you may not get those high voltages, so just try and get them charged to full. Conventional chargers usually have a shutoff when they determine full charge. So then just use that voltage for turning off the Bedini Monopole SSG.

Do enough cycles so that you are certain of the trends. If you see an increase of load time in the Monopole SSG, you may want to continue until that comes to a peak end.

When you conclusively see that the regular charger has significantly reduced its load time, then you may want to start charging it on the Monopole SSG to see if that trend can be reversed.

Bedini Monopole 3 Group Experiment

Invitation to the Advanced Groups

OK, so by now you should have successfully built the Bedini Monopole SSG, tuned it to its “sweet spot” and completed the basic load testing.

So, what have you learnt?

- What is charging the battery?
- What does the amp meter indicate is going into the battery?
- What do we get out of the battery on a repeated basis?

Member's who have successfully completed building the Bedini Monopole SSG, have uploaded their basic load test data and have shown that they understand the basic concepts of this technology may now be invited to participate in the advanced Bedini groups to further their research.

There are many, many, more Bedini advanced designs that may be replicated for the experimenter's personal use. Schematics and building tips can be found on the advanced lists and other advanced builders are free to discuss their replications.

Resources for history, theory, and advancement.

There are many resources available for those members who wish to further their knowledge of the Bedini technology.

John Bedini has spent over 30 years developing this technology and has several U.S. and international patents to his name. He has based his research on the work of Nikola Tesla and has worked with many other noted scientists, physicists and inventors in this field.

The Internet is a valuable tool for researching this technology. Apart from the web sites that have already been listed, here are some more that are very useful.

<http://www.rexresearch.com/johnson/1johnson.htm> - Howard Johnson: Permanent Magnet Motor
<http://www.icehouse.net/john34/bedinibearden.html> - 20 Bedini_Bearden Years: Free Energy Generation
– By Tom Bearden and John Bedini
<http://www.icehouse.net/john1/index101.htm> - John Bedini's Formation of Negative Resistors in Batteries
- By Tom Bearden
[John Bedini's US Patent 6,454,444](#)

Or Google “Tesla”, “Bearden”, “Bedini”, etc.

There are also several books and DVDs on the market that may interest you. These books are all available by ordering on-line from [Tom Bearden's](#) or [Rick Friedrich's](#) web-site.

Free Energy Generation – Circuits and Schematics. By Tom Bearden and John Bedini, 2006 (includes John Bedini's original book from 1984)

Energy From The Vacuum – Concepts & Principles. By Tom Bearden, 2002.

Energy From The Vacuum – DVD Part 1 (Overview – Tom Bearden)

Energy From The Vacuum - DVD Part 2 (John Bedini)

Energy From The Vacuum – DVD Part 4 (Howard Johnson)

Energy From The Vacuum – DVD Part 5 (HIDDEN ELECTRODYNAMICS and THE FINAL SECRET OF FREE ENERGY)

Bedini Monopole 3 Group Experiment

Conclusion

We hope that this manual has helped you understand more about the *John Bedini Monopole Mechanical Oscillator Energizer with Simplified Schoolgirl Circuit (SSG)* and how to build it.

This machine may look very simple from the outset, but is in fact very complex in its operation. The way John Bedini has simplified the Energizer so it is simple to build to anyone with basic skills is a testament to his genius. Advanced builders that have built more advanced Bedini systems still marvel at the elegant simplicity of the Monopole SSG's design, as well as continuing to solve some of the more complex riddles that it holds.

Once someone has a grasp of the basic concepts of the Monopole SSG and understands the different types of energy involved, then can they easily move onto the more advanced systems which all have the basic concepts in common.

All the best in your research!