

Practical Guide to 'Free-Energy' Devices

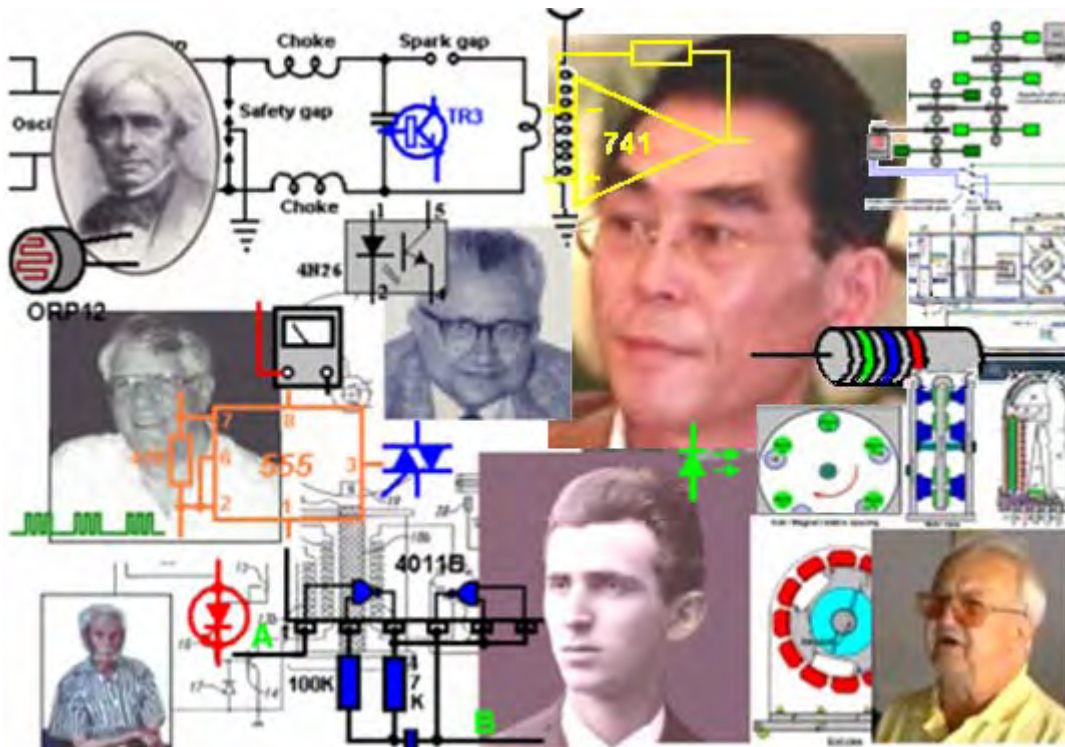

Author: Patrick J. Kelly

Version: 24.3 Release date: 5th October 2013

This eBook has more than 400 bookmarks to speed up your access to any section of interest. The contents of this eBook is only about 5% of the information on the <http://www.free-energy-info.tuks.nl> web site

A Practical Guide to 'Free-Energy' Devices

Preface

Here is a small amount of background information in order that you can understand the nature of this “**Practical Guide to Free-Energy Devices**”.

I am just an ordinary person who became interested in “free-energy” as a result of a television programme entitled ‘It Runs on Water’ shown in the 1980s by a UK television company called ‘Channel 4’. This programme has since been put on the internet and at this time can be seen at www.youtube.com/watch?v=vghjGwvmrqE. From my point of view, the content of this documentary seemed to be rather unsatisfactory as it suggested quite a number of very interesting things but gave no real hard and fast specifics for the viewer to follow up on to investigate the subject further. However, it had the enormous benefit of making me aware that there was such a thing as “free-energy”.

My attempts to find out more were not very successful. I bought paper copies of several of Stan Meyer’s hydroxy gas patents from the Patent Office in 1986 but while they were interesting, they did not provide much in the way of additional information. Searching on the internet at that time did not produce much more in the way of practical information. Things have changed dramatically since then and there has been an enormous increase in available information. But, even today, it is relatively difficult to find direct, useful and practical information on free-energy systems and techniques. Much of the information consists of chatty, lightweight articles describing people, events and inventions in vague, broad outline terms which are almost completely lacking in specifics.

These articles have the style of saying “There is a new invention called a ‘bus’ which is used to carry passengers from place to place. We saw one the other day, it was painted green and blue and looked most attractive. It is driven by Joe Bloggs who wears an engaging smile and a hand-knitted sweater. Joe says that even his children could drive a bus as it is so easy to do. Joe expects to retire in six months time as he is going to take up gold prospecting.” While I’m sure that an article like that is interesting, the sort of description which I would want would be: “There is a new invention called a ‘bus’ which is used to carry passengers from place to place. We saw one the other day, and were very impressed as it has seats for some forty-five people. It has bodywork made of pressed aluminium, a wheel at each corner of its considerable 40’ x 10’ structure, a five litre diesel engine made by the Bosworth Engineering Company of Newtown, and has power-assisted steering, hydraulic brakes and

There are also many articles, scientific papers and books which, quite frankly, I am not able to understand as the authors think mathematically and express themselves in equations (where they frequently do not define the terms which they use in their equations, making them effectively meaningless). I do not think in mathematical equations, so I do not share in this much higher level of thinking and analysis, though I do have some of these papers on my web site for the benefit of visitors who do have the ability to understand them easily.

After a long period of searching and investigating I was beginning to gather enough information to be fairly confident of what was being done, what had already been achieved, and some of the possible background reasons for the effects which were being observed. Early in 2005 I decided that as I had encountered so much difficulty and had to put in so much effort to find out the basics of “free-energy” that it could be helpful to others if I shared what I had found out. So I wrote the first edition of this presentation and created a simple web site to make it available to others. Of course, this body of information is not static – on the contrary, it is very fast-moving. Consequently, this information digest is updated and refined typically once or twice per week. The present form of presentation is the third style of layout which has been used as the volume of material has increased.

It should be stressed that this information is what I have discovered as part of my interest in the subject and is mainly a reporting on what is being said by other people. I have not built and proved every device described – to do that would take many lifetimes, so please understand that this is just an attempt to aid your own investigation. While it can be proved that some device works as described, through independent replication and verification, the reverse is not true. If someone were to build a device and fail to get it to work as described, then the most that can honestly be said is that an unsuccessful attempt was made to replicate it. It does not, of course, show that the original device did not operate exactly as described, just that the (possibly inept) attempt at replication, was not successful. In some instances, you will see that I have expressed the opinion that the device is not viable, or,

as in the case of the 'Nitro Cell' that I do think that it does work, but as many people have tried to build it and failed to get the results described, that it can't be recommended as an investigation project.

I do not suggest that this set of information covers every possible device, nor that my description is by any means the complete and definitive statement of everything to be known on the subject. The old saying applies here: "If you think you know all the answers, then you just haven't heard all the questions!" So, this material is just an introduction to the subject and not an encyclopaedia of every known device.

I should like to thank the very large number of people who have most kindly given me their permission to reproduce details of some of their work, providing photographs, checking what I have written, suggesting additions, etc. Also those kind people who have given me permission to reproduce their own works directly on my web sites or in my documents. There seems to be a common thread of concern among many people that shows as a desire to share this information freely rather than to try to make money from selling it, and I thank these people for their generosity.

Many people hold "conspiracy theory" views and believe that there is a concerted effort to suppress this information, and more especially, to prevent free-energy devices reaching the market. Personally, I think that while that is certainly true, the bulk of this opposition is just the normal reaction of vested commercial interests. If you were making a profit of literally millions per hour, would you welcome the introduction of a system which would eventually cut your income to zero? If not, then how much would you be willing to pay someone to make sure that the present system is never changed – a million? A billion? While this opposition is definitely there and people who stand to lose money and/or power through change will continue to oppose this knowledge, and to a much greater extent, the introduction of any commercial free-energy device, this is not something which I feel is immediately relevant to this presentation, and so almost the entire focus of the information is on devices – what they do, how they are made and how they may operate when they draw additional energy from the local environment.

Let me stress again, that this set of information is not by any means the final word on the subject, but just an introduction to the subject by a single person who makes no claims to knowing all the answers. Enjoy your research – I hope you are successful in every respect.

Patrick Kelly

April 2008

A Practical Guide to 'Free-Energy' Devices

Contents

Index	1
Introduction	I -1
Chapter 1: Magnet Power	
The ShenHe Wang permanent magnet motor-generator	1 - 1
The Ecklin-Brown generator	1 - 4
The Howard Johnson magnet motor	1 - 6
The 'Carousel' permanent magnet motor	1 - 7
The Robert Tracy permanent magnet motor	1 - 9
The Ben Teal electromagnet motor	1 - 9
The Jines permanent magnet motor	1 - 11
The Stephen Kundel permanent magnet motor	1 - 12
Charles Flynn's permanent magnet motor	1 - 15
Steorn's Magnet Motor	1 - 24
George Soukup's Magnet Motor	1 - 26
Dietmar Hohl's V-Magnet Motor and Jes Ascanius' implementation of it	1 - 29
Constructing a simple permanent magnet motor	1 - 30
Muammer Yildiz's Magnet Motor	1 - 35
Donald Kelly's Magnet Motor	1 - 54
Mike Brady's Perendev Magnet Motor	1 - 55
Chapter 2: Moving Pulsed Systems	
The Adams Motor/Generator	2 - 1
The Phemax Self-Powered motor/generator	2 - 12
The Kromrey No-Drag Electrical Generator	2 - 15
The Teruo Kawai Motor.	2 - 23
James Hardy's Water-jet Generator	2 - 25
Georges Mourier's COP=10,000 Motor/Generator Patent	2 - 27
The RotoVerter	2 - 37
Coil-shorting techniques	2 - 42
Raoul Hatem's Energy System.	2 - 46
Lawrence Tseung's COP = 3.3 Pulsed Rotor	2 - 48
Art Porter's Electromagnetic Motor System.	2 - 54
Raising DC Motor Efficiency	2 - 55
Chapter 3: Motionless Pulsed Systems	
Charles Flynn's devices	3 - 1
Lawrence Tseung's magnetic frame	3 - 1
Thane Heins' dual toroidal magnetic frame.	3 - 3
Cascading magnetic frames	3 - 6
The High-power Motionless Generator of Clemente Figuera	3 - 8
The Self-Powered Generators of Barbosa and Leal	3 - 28
The Motionless Generator of Theodore Annis and Patrick Eberly	3 - 61
The Richard Willis COP>1 Motionless Electrical Generator.	3 - 62
The 'silverhealtheu' bar generator	3 - 64
Stephan W. Leben's device	3 - 65
Floyd Sweet's VTA	3 - 66
Pavel Imris' Optical Generator	3 - 68
The Michel Meyer and Yves Mace Isotopic Generator	3 - 70
The Colman / Seddon-Gilliespie Generator.	3 - 71
Don Smith's Magnetic Resonance System	3 - 73
Using two Tesla Coils back-to-back	3 - 73
Joseph Boyd's power transformer	3 - 75
The 'Gegene' Magnetic Plate Arrangement	3 - 89
Tariel Kapanadze's Self-powered Devices	3 - 91

An analysis of the Kapanadze devices	3 - 96
The Cold Electricity Coil of 'UFOpolitics'	3 - 97
Stanley Meyer's Magnetic Particles Power Generator	3 - 106

Chapter 4: Gravity-Powered Systems

Lawrence Tseung's Gravity Impact wheel	4 - 1
The Chas Campbell System	4 - 4
Jacob Bitsadze's Pulley Ratio Information	4 - 9
The Wilson self-powered DC generator	4 - 10
The Bedini Pulsed Flywheel	4 - 11
James Hardy's Water-jet Generator	4 - 12
The Two-year magnetic Pendulum	4 - 12
Jerzy Zbikowski's Chain Drive system	4 - 16
Gravitational Effects	4 - 17
Mikhail Dmitriev's nudged weights gravity wheel	4 - 18
The Dale Simpson Gravity Wheel	4 - 21
Abdulsalam Al-Mayahi's Gravity Wheel	4 - 23
The Veljko Milkovic Pendulum / Lever system	4 - 27
Amr Al-Hossary's Hinged-PlateDesign	4 - 28
The Murilo Luciano Gravity Chain	4 - 28
Other Gravity Designs	4 - 37
James Kwok's "Hidro" Self-Powered Generator	4 - 37
The Ribero Buoyancy Patent	4 - 50

Chapter 5: Energy-Tapping Pulsed Systems

Frank Prentice's horizontal wire system	5 - 1
Dave Lawton's Water Fuel Cell	5 - 3
John Bedini's Battery Pulse-Charger	5 - 4
The Tesla Switch	5 - 5
A 3-Battery Switching Circuit	5 - 11
The Self-powered Free-Energy Generators of Carlos Benitez	5 - 20
Bozidar Lisac's 1-battery charger patent	5 - 37
Bob Boyce's Toroid	5 - 46
Don Smith's devices	5 - 52
Tariel Kapanadze's system	5 - 53
The insights of Vladimir Utkin	5 - 53
Walter Ford's high-powered crystal set	5 - 54
Lawrence Tseung's "FLEET" toroid	5 - 56
Advanced Joule Thief circuits	5 - 61
LaserSaber's Joule Thief lighting circuits	5 - 79
The Ed Gray / Marvin Cole Power System	5 - 81
Tesla's Experiments	5 - 83
The Alberto Molina-Martinez Generator	5 - 89
The Hubbard Self-powered Generator	5 - 90
The Joseph Cater Self-powered Generator	5 - 93
Floyd Sweet's VTA	5 - 100
Rosemary Ainslie's COP=17 heater	5 - 102
Joseph H Cater's Self-sustaining generator	5 - 103
Dr Oleg Gritskevitch's COP=100 1.5 MW generator	5 - 104

Chapter 6: Battery-Charging Pulsed Systems

Bedini Pulsing	6 - 2
Roger Andrews' switching system	6 - 2
Ron Knight's professional battery advice	6 - 5
Ron Pugh's Charger	6 - 5
Ossie Callanan's charging system	6 - 18
The Self-charging system	6 - 24
The Relay Coil Battery Charger	6 - 25
The Re-wired Fan Charger	6 - 26
The Automotive Coil Charger	6 - 28
The Self-charging Motor	6 - 29
The Alexkor multiple battery charger	6 - 30
Howerd Halay's cold electricity conditioning	6 - 38
The Ron Cole One-Battery Charger	6 - 40

The Tesla Switch.	6 - 41
The self-charging motor	6 - 42
The 'UFOpolitics' motor	6 - 45
Some battery charging suggestions	6 - 46

Chapter 7: Aerial Systems and Electrostatic Generators

Nikola Tesla's Aerial Plate Power System	7 - 1
The Jes Ascanius replication of Tesla's Aerial Plate System	7 - 9
The printed circuit board of Dragan Kljajic	7 - 12
Thomas Henry Moray's System.	7 - 14
Herman Plauson's System.	7 - 30
Roy Meyer's System	7 - 32
Raymond Phillips' RF System.	7 - 33
The 'Alexkor' Aerial System	7 - 37
The 'TREC' Aerial System of Lawrence Rayburn	7 - 38
The Patent Application of Harold Deyo	7 - 40
The Electrostatic Generator of Charles Goldie	7 - 50
The Electrostatic Generator of D. Le May.	7 - 54
The Electrostatic Generator of Onezime Breaux	7 - 67

Chapter 8: Fuel-less Motors

The Bob Neal Motor	8 - 1
The Scott Robertson air compressor.	8 - 4
The Leroy Rogers Motor	8 - 6
The Vortex Tube	8 - 21
The Eber Van Valkinburg Motor	8 - 23
The Clem Motor	8 - 23
The Papp Motor	8 - 25
The Robert Britt Motor	8 - 28
The Michael Eskeli Turbine	8 - 28
James Hardy's Water-Jet Generator.	8 - 47
The Cahill & Scott Generator	8 - 48

Chapter 9: Passive Systems

Hans Cohler's device	9 - 1
Thomas Trawoeger's pyramid.	9 - 3
Peter Grandics' pyramid	9 - 20
Les Brown's pyramid	9 - 22
Joseph H. Cater's explanation of how a pyramid actually works	9 - 29
Pier Luigi Ighina's "ERIM" and "Elios" passive devices.	9 - 31
The Joe Cell	9 - 35
Co-axial Cable Electrets	9 - 67
Joseph Cater's free-energy box.	9 - 69

Chapter 10: Vehicle Systems

Booster design	10 - 1
Simple DC boosters	10 - 2
The "Smack's" booster	10 - 17
The "Hotsabi" booster.	10 - 18
The Zach West booster.	10 - 18
Bill Williams' "DuPlex" booster	10 - 27
The 'Hogg' Electrolyser.	10 - 28
Advanced Boosters	10 - 33
The Bob Boyce DC electrolyser.	10 - 33
Pulsed Water-Splitters	10 - 34
Dave Lawton's Meyer Replication	10 - 34
Dr Cramton's water-splitter.	10 - 53
Bob Boyce's Toroidal water-splitter	10 - 59
John Bedini Water-Splitting	10 - 60
Dave Lawton's Auto-Tune Circuit.	10 - 61
Running an Electrical Generator on Water Alone	10 - 62
Running an Unmodified Generator on Water Alone.	10 - 85
Stan Meyer's Water Injection System	10 - 89

Peter Lindemann running a lawnmower on water alone	10 - 94
Peter Lowrie's High-Current Electrolyser System	10 - 95
Water use in engines	10 - 96
Ted Ewert's Vortex Tube	10 - 99
Cam timing Issues	10 - 104
Robert Krupa's 'FireStorm' Spark Plug	10 - 105
Plasma Ignition	10 - 106
Roger Maynard's Water Vapour Injection System.	10 - 107
"Fuelsavers" streamlining	10 - 109
The Ram Implosion Wing	10 - 109
High mpg Carburettors	10 - 109
Allen Caggiano's High-mpg carburettor	10 - 111
A Fuel Vapourisation System	10 - 115
Vortex Fuel Reforming (GEET)	10 - 116
Electric Power	10 - 118
The Weird Nature of Water and Advanced Electrolysis	10 - 120
The Electrolyser of Charles Garrett	10 - 126
The Electrolyser of Archie Blue	10 - 127
The HHO cell of Paul Zigouras	10 - 129

Chapter 11: Other Devices and Theories

The Tesla Generators.	11 - 1
The Aspden Device	11 - 3
Paulo & Alexandra Correa	11 - 15
Professor Konstantin Meyl	11 - 16
Tesla's MHD unit.	11 - 16
The Unified Field Theory	11 - 18
Maurice Cotterell's Explanation of Gravity	11 - 22
John R. R. Searle	11 - 32
The Gravity Wave Detector	11 - 33
The Butch Lafonte Motor / Generator	11 - 35
The Joseph Newman's COP = 8 Device	11 - 40
Daniel Cook's Induction Coil.	11 - 51
Michael Eskell's Fuel-less Heater	11 - 53
Karl Schappeller's Free-energy Device	11 - 60
Condensation-Induced Water Hammer	11 - 75
William Hyde's COP = 10 Electrostatic Power Generator	11 - 76
The Suppression of Knowledge.	11 - 85

Chapter 12: Electronics Tutorial

Voltage.	12 - 1
Resistance	12 - 2
Semiconductors – Transistors.	12 - 10
Diodes	12 - 19
Alternating Current.	12 - 21
Coils (Inductors)	12 - 21
The Ben Teal Motor	12 - 23
Transformers	12 - 21
Rectification and Power Supplies.	12 - 26
Multivibrators	12 - 29
The Bistable.	12 - 29
The Monostable	12 - 30
The Astable	12 - 31
Inverters	12 - 32
Digital Logic and Truth Tables.	12 - 32
The NAND gate and Gating	12 - 34
The Latch	12 - 37
The NE555 Timer Chip	12 - 41
The 741 Op-amp Chip	12 - 56
The SCR (Thyristor).	12 - 59
The Triac	12 - 59
A simple, versatile, Schmitt inverter signal generator.	12 - 62
The CD4022BC Divide-By-Eight Chip	12 - 62

The cascaded CD4017B Divide-By-N circuitry	12 - 64
The PIC chip	12 - 66
Capacitors	12 - 71
AC Circuitry, inductors and resonance	12 - 73
Choosing unspecified component values	12 - 78
Prototype Construction	12 - 81
Test Equipment	12 - 85
Power Supply Unit	12 - 88
The Oscilloscope.	12 - 90
Measuring magnetic field strength	12 - 91
The Weird Stuff.	12 - 92

Chapter 13: Doubtful Devices

Paul Baumann's "Thestakia".	13 - 1
The Homopolar or "N-Machine".	13 - 4
The Borderland Science Homopolar AC Generator.	13 - 5
The "Romag" and "Mini-Romag" Generators.	13 - 6
Cold Fusion	13 - 9
Moller's Atomic Hydrogen Generator	13 - 9
Muammer Yildiz's "Ocean Star" Electrical Generator.	13 - 11
Jesse McQueen	13 - 18
The Nitro Cell ("D18").	13 - 21
The HydroStar and HydroGen.	13 - 40
Hydrogen from Aluminium	13 - 44
Francois Cornish.	13 - 45
Ultrasonic water-splitting	13 - 46
Valeri Ivanov's Motionless Generator	13 - 47
The MEG	13 - 48
Dave Lawton's assymetric MEG variation	13 - 50
The Hitch-Hiker's MEG description.	13 - 51
The Devices of Hans Coler	13 - 60

Chapter 14: Renewable Energy Devices

Heaters	14 - 1
The Wood-gas Stove	14 - 1
Mr Teslonian's wood-gas stove / electrical generator / fuel producer	14 - 4
The solid-fuel electricity stove	14 - 5
Henry Paine's HHO patent.	14 - 7
Sang Nam Kim's HHO heaters	14 - 7
Eugene Frenette	14 - 10
Eugene Perkins	14 - 10
The Peter Davey Heater	14 - 14
The re-wired halogen heater.	14 - 16
Home-build Wind Generator.	14 - 16
William McDavid's Wind-Power or Water-Power Generator	14 - 17
Frank Herbert's Wind Generator	14 - 18
Mead and Holmes Power System	14 - 20
Solar Ovens.	14 - 21
Solar Water Pasteurisation.	14 - 41
Solar Water Stills.	14 - 47
Sonic Water Pumps	14 - 55
The Ram Pump	14 - 57
Discouraging mosquitoes and small flies.	14 - 59
Wave Power	14 - 60
Cooling Using Heat	14 - 64
Solar Panels	14 - 66

Chapter 15: The Present Situation

Why free-energy devices are not in your local shop	15 - 1
--	--------

Chapter 16: Questions and Answers

What to Build 16 - 1
Questions on Electrolysis 16 - 7
Questions on Magnet Motors 16 - 17
Questions on Don Smith's Devices. 16 - 19
Questions on General Topics 16 - 22

Appendix

US and UK Wire sizes and capacities	A -1
Frank Fecera's permanent magnet motor patent	A - 2
Howard Johnson's permanent magnet motor patent	A - 46
Harold Ewing's Carousel permanent magnet-generator patent.	A - 56
The Pavel Imris minimal power lighting system patent	A - 74
The Colman/Seddon-Gillespie 70-year battery patent	A - 83
The Jon Sok An Lenz-less electrical generator patent	A - 87
The Molina Martinez self-powered electrical generator patent	A - 100
Michael Ognyanov's solid-state electrical generator patent	A - 113
Edwin Gray's electric motor patent	A - 119
Edwin Gray's electric power supply patent	A - 142
The Adams-Aspden electrical motor-generator patent	A - 148
William Barbat's self-powered electrical generator patent	A - 164
John Reardon's AC generator patent	A - 196
Geoffrey Spence's self-powered electrical generator patent	A - 213
Robert Alexander's COP = 2.93 electrical generator patent.	A - 228
Shigeaki Hayasaka's electrical generator patent	A - 236
Larry Jamison's electrical generator patent application	A - 252
Teruo Kawai's COP>1 electric motor patent	A - 259
Joseph Newman's Energy Generator patent	A - 280
Philip Brody's very high output ceramic solar devices patent	A - 298
Charles Flynn's controlled magnetic devices patent	A - 338
The Motionless Electromagnetic Generator patent	A - 411
Dan Davidson's acoustic-magnetic electrical generator patent.	A - 427
John Bedini's battery-charging patent	A - 434
John Bedini's motor-generator patent	A - 445
John Bedini's pulse-charging system patent	A - 456
Richard Weir and Carl Nelson's battery replacement patent	A - 470
Hermann Plauson's aerial power systems patent	A - 485
Roy Meyers' Electricity-producing device patent	A - 524
Paulo and Alexandra Correa's free-electricity patent	A - 532
Paulo and Alexandra Correa's energy conversion patent	A - 561
The Mead-Nachamkin ZPE to electricity conversion patent.	A - 603
Stanley Meyer's Water Fuel patent 4,936,961	A - 620
Stanley Meyer's hydrogen injection system for vehicles patent 4,389,981	A - 627
Stanley Meyer's hydrogen gas burner patent 4,421,474.	A - 637
Stanley Meyer's hydrogen generation and enhancement patent 5,149,407	A - 642
Stanley Meyer's water fuel generator patent CA 2,067,735	A - 659
Stanley Meyer's WFC control circuitry patent WO 92/07861	A - 670
Stephen Meyer's water-splitting patent application 2005/0246059	A - 680
Henry Puharich's water-splitting patent 4,392,230	A - 689
Shigeta Hasebe's spiral electrolyser patent	A - 719
Stephen Chambers' hydroxy generator patent (Xogen Power Inc.)	A - 725
Charles Garrett's water carburettor patent	A - 740
Archie Blue's electrolyser patent	A - 748
Ruggero Santilli's plasma arc electrolysis patent	A - 754
Chak Chang's low-voltage low-temperature plasma patent application.	A - 764
Juan Aguero's water-engine patent application	A - 823
Stephen Horvath's water-powered car patent	A - 830
Christopher Eccles' water-splitting cell patent	A - 857
Spiro Spiros' COP>1 electrolyser patent	A - 864
Henry Paine's hydroxy gas conversion patent	A - 901
Boris Volfson's gravity drive patent.	A - 904
Charles Pogue's first high-mpg carburettor patent	A - 919
Charles Pogue's second high-mpg carburettor patent	A - 927
Charles Pogue's third high-mpg carburettor patent	A - 932
Ivor Newberry's high-mpg carburettor patent.	A - 940
Robert Shelton's high-mpg carburettor patent	A - 945
Harold Schwartz's high-mpg carburettor patent	A - 949
Oliver Tucker's high-mpg carburettor patent	A - 952
Thomas Ogle's high-mpg carburettor patent	A - 955
Stephen Kundel's permanent magnet motor	A - 968
Charles Flynn's permanent magnet motor	A - 992
Claude Mead and William Holmes' wind power storage system	A - 1021

The Richard Willis COP>>1 electrical generator	A - 1028
Graham Gunderson's pulsed toroid generator	A - 1038
Mark McKay's investigation into Edwin Gray's technology	A - 1046
Mike Brady's "Perendev" magnet motor patent	A - 1107
Donald Kelly's magnet motor patent	A - 1117
Bob Neal's compressor patent	A - 1125
Leroy Rogers' compressed air engine patent	A - 1132
Eber Van Valkinburg's compressed air/oil engine patent	A - 1148
Josef Papp's inert-gas engine patent	A - 1153
Robert Britt's Inert-gas engine patent	A - 1186
Floyd Sweet's "VTA" Electrical Generator	A - 1196
Meguer Kalfaian's Electrical Generator	A - 1210
Theodore Annis and Patrick Eberly's Motionless Generator	A - 1220
William McDavid's Wind-Power or Water-power Generator.	A - 1232
The Self-powered Generators of Barbosa and Leal	A - 1252
Web links to Scientific Papers and Videos	A - 1283

Alphabetical Index of Devices

AC generator patent, John Reardon	A - 196
Acoustic water pumps: Bellocq, Dickinson and Benson	14 - 60
Advanced Electrolysis, Moray B. King	10 - 120
Aerial power systems patent, Hermann Plauson	A - 485
Aerial system, Frank Prentice	5 - 1
Aerial system, Jes Ascanius	7 - 9
Aerial system, Lawrence Rayburn	7 - 38
Aerial system, Nikola Tesla	7 - 1
Aerial system, Raymond Phillips	7 - 33
Aerial system, Thomas Henry Moray	7 - 14
Air Vortex Turbine, Ted Ewert	10 - 89
Aspden Effect, Harold Aspden	5 - 63
Asymmetrical Motionless Generator, Dave Lawton	13 - 50
Atomic Hydrogen generator, William Lyne	13 - 9
Automotive Relay battery pulser, Imhotep	6 - 28
Battery-charging patent, John Bedini	A - 434
Battery-pulser, Alexkor	6 - 30
Battery-pulser, Bozidar Lisac	5 - 37
Battery-pulser, John Bedini	6 - 2
Battery-pulser, Ossie Callanan	6 - 18
Battery-pulser, Ron Pugh	6 - 5
Battery replacement patent, Richard Weir and Carl Nelson	A - 470
Battery technology, Ronald Knight	6 - 5
Blood electrifier, Bob Beck	11 - 88
Boosters, Various	10 - 1
Britt Engine	8 - 28
Buoyancy patent, Renato Ribera	4 - 50
Capacitor Battery Pulser, Ron Cole	6 - 40
Caravan Power System, Claude Mead and William Holmes	14 - 20
Car relay pulse charger, Imhotep	6 - 28
Chain Drive, Jerzy Zbikowski	4 - 16
Clem engine, Richard Clem	8 - 23
Co-axial Cable Electrets	9 - 67
Cold Electricity Coil of 'UFOPolitics'	3 - 97
Colloidal Silver, Bob Beck	11 - 88
Compressed-air engine, Bob Neal	8 - 1
Compressed-air engine, Leroy Rogers	8 - 6
Compressed-air tank, Scott Robertson	8 - 4
Compressed-air/oil engine, Eber Van Valkenburg	8 - 23
Controlled magnetic devices patent, Charles Flynn	A - 338
COP = 2.93 electrical generator patent, Robert Alexander	A - 228
COP>1 electric motor patent, Teruo Kawai	A - 259
COP>1 electrolyser patent, Spiro Spiros	A - 864
Davey water heater, Peter Davey	14 - 14
Drinking Water Systems	14 - 47
Electrets	9 - 68
Electrical energy from air, Nikola Tesla	11 - 1
Electrical free-energy generation, Harold Aspden	11 - 3
Electrical generator, Alfred Hubbard	5 - 90
Electrical generator, Arthur Cahill & John Scott	8 - 48
Electrical generator, Joseph Cater	5 - 103
Electrical generator, Alberto Molina-Martinez	5 - 89
Electrical generator, Clemente Figuera	3 - 8
Electrical generator, Borderland Science	13 - 6
Electrical generator, Ecklin-Brown	1 - 4
Electrical generator, Dr Oleg Gritskevitch	5 - 104
Electrical generator patent application, Larry Jamison	A - 252
Electrical generator, Meyer-Mace	3 - 70
Electrical generator, Raoul Hatem	2 - 46
Electrical generator, Raymond Kromrey	2 - 15
Electrical generator, Richard Willis	3 - 64
Electrical generator, self-powered, Mr Wilson	4 - 10
Electrical Generator, 'silverhealtheu'	3 - 64

Electrical generator patent, Shigeaki Hayasaka	A - 236
Electrical Generator, Stan Meyer	3 - 76
Electrical Generator, Taniel Kapanadze	3 - 91
Electrical motor-generator patent, Adams-Aspden	A - 148
Electricity-producing device patent, Roy Meyers	A - 524
Electricity-producing solid-fuel stove	14 - 5
Electric motor, Ben Teal	1 - 9
Electric motor, Ben Teal	4 - 6
Electric motor patent, Edwin Gray	A - 119
Electrical motor, Georges Mourier	2 - 27
Electrical motor, Edwin Gray	5 - 81
Electric motor, Robert Adams	2 - 1
Electric motor, Teruo Kawai	2 - 23
Electric power supply patent, Edwin Gray	A - 142
Electrolyser, Archie Blue	10 - 128
Electrolyser, Bob Boyce	5 - 46
Electrolyser, Bob Boyce	10 - 33
Electrolyser, Bob Boyce	10 - 59
Electrolyser, Charles Garrett	10 - 126
Electrolyser, Paul Zigouras	10 - 129
Electrolyser, Peter Lowrie	10 - 95
Electrolyser, Selwyn Hughes	10 - 95
Electrolyser, Zach West	10 - 18
Electrolyser patent, Archie Blue.	A - 748
Electrostatic Power Generator, Onezime Breaux	7 - 67
Electrostatic Power Generator, Charles Goldie	7 - 50
Electrostatic Power Generator, William Hyde	11 - 76
Electrostatic Power Generator, D. Le May	7 - 54
Elios device, Pier Luigi Ighina	9 - 34
Energy-conversion patent, Paulo and Alexandra Correa	A - 561
Energy Generator patent, Joseph Newman	A - 280
ERIM device, Pier Luigi Ighina	9 - 31
Fan Battery Pulser, Imhotep	6 - 26
FireStorm spark plug, Robert Krupa	10 - 105
FLEET power toroid	5 - 56
Francois Cornish hydrogen generator	13 - 45
Free-electricity patent, Paulo and Alexandra Correa	A - 532
Free-energy box, Joseph H Cater	9 - 69
Free-energy device, Karl Schappeller	11 - 60
Fuelsavers	10 - 109
Fuji camera circuit adaption	5 - 62
GEET fuel re-former system, Paul Pantone	10 - 107
Generator running on water alone	10 - 63
Gravity-chain device, Murilo Luciano	4 - 28
Gravity device, Amr Al-Hossary.	4 - 28
Gravity drive patent, Boris Volfson	A - 904
Gravity-tapping generator, Chas Campbell.	4 - 4
Gravity Wave Detector, Dave Lawton	11 - 33
Gravity wheel, Abdulsalam Al-Mayahi	4 - 23
Gravity wheel, Dale Simpson	4 - 21
Gravity wheel, Lawrence Tseung.	4 - 1
Gravity wheel, Mikhail Dmitriev	4 - 18
Heater, Fuel-less, Michael Eskeli.	11 - 53
Heater, COP=17 by Rosemary Ainslie	5 - 102
Heaters	14 - 1
Heater, Magnetic.	16 - 39
Hidro Generator, James Kwok	4 - 39
High-mpg carburettor patent, Charles Pogue	A - 919
High-mpg carburettor patent, Charles Pogue	A - 927
High-mpg carburettor patent, Charles Pogue	A - 932
High-mpg carburettor patent, Harold Schwartz	A - 949
High-mpg carburettor patent, Ivor Newberry	A - 940
High-mpg carburettor patent, Oliver Tucker	A - 952
High-mpg carburettor patent, Robert Shelton	A - 945
High-mpg carburettor patent, Thomas Ogle	A - 955

Hinged-Plate Gravity Device, Amr Al-Hossary	4 - 28
Hogg electrolyser	10 - 28
Homopolar generator, Michael Faraday	13 - 4
Hotsabi booster, "Hotsabi"	10 - 18
Hydraulic Ram Pump	14 - 57
Hydrogen from Aluminium	13 - 44
Hydrogen gas burner patent 4,421,474, Stanley Meyer	A - 637
Hydrogen generation and enhancement patent 5,149,407, Stanley Meyer	A - 642
Hydrogen injection system for vehicles patent 4,389,981, Stanley Meyer	A - 627
HydroStar and HydroGen devices	13 - 40
Hydroxy gas conversion patent, Henry Paine	A - 901
Hydroxy generator patent, Stephen Chambers	A - 725
Hydroxy-burning heaters	14 - 7
Induction Coil generator, Daniel Cook	11 - 51
Inert-gas engine, Josef Papp	8 - 25
Inert-gas engine, Robert Britt	8 - 28
Inverter system, Jesse McQueen	13 - 18
Joe Cell, Joe Nobel	9 - 35
Joseph Newman Motor, Joseph Newman	11 - 40
Joule Thief advanced circuits	5 - 79
Joule Thief lighting circuits	5 - 79
Lead-out energy, Lawrence Tseung	4 - 1
Lawnmower running on water alone	10 - 94
Lenz-less electrical generator patent, Jon Sok An	A - 87
Long-life battery, Colman / Seddon-Gillespie	3 - 71
Low-voltage low-temperature plasma patent application, Chak Chang	A - 764
Magnet motor-generator, permanent 5kW, Shen He Wang	1 - 1
Magnet Motor, Art Porter	2 - 55
Magnet motor, Carousel	1 - 7
Magnet-generator patent, Carousel	A - 56
Magnet motor patent, Charles Flynn	1 - 15
Magnet Motor, Dietmar Hohl	1 - 29
Magnet Motor, Jes Ascanius	1 - 29
Magnet motor patent, Frank Fecera	A - 2
Magnet Motor, George Soukup	1 - 26
Magnet motor, Howard Johnson	1 - 6
Magnet motor patent, Howard Johnson	A - 46
Magnet motor, John Jines	1 - 11
Magnet motor, Donald Kelly	1 - 54
Magnet motor, Perendev (Mike Brady)	1 - 55
Magnet motor, Robert Tracy	1 - 9
Magnet motor, simple	1 - 30
Magnet motor, Steorn	1 - 24
Magnet motor, Stephen Kundel	1 - 12
Magnetic Conversion, Don Smith	3 - 73
Magnetic Conversion, Don Smith	5 - 52
Magnetic flux, Charles Flynn	3 - 1
Magnetic frame, cascading	3 - 6
Magnetic frame, Lawrence Tseung	3 - 1
Magnetic frame, Thane Heins	3 - 3
Magnetic Plate, The 'Gegene'	3 - 86
Magnetohydrodynamic drive, Nikola Tesla	11 - 17
MEG, Tom Beardon et al.	13 - 48
Minimal power lighting system patent, Pavel Imris	A - 74
Motionless Generator of Valeri Ivanov	13 - 47
Motionless Electromagnetic Generator patent	A - 411
Motor-generator, Butch Lafonte	11 - 35
Motor-generator patent, John Bedini	A - 445
Motor-generator patent, Georges Mourier	2 - 27
N-machine generator, Michael Faraday	13 - 2
Neal Compressed-air Engine	8 - 1
Nitro Cell	13 - 20
Ocean-Star generator, Muammer Yaldiz	13 - 11
One-battery switch, Ron Cole	6 - 40
Optical Amplifier, Pavel Imris	3 - 68

Pancake Coil, Nikola Tesla	5 - 63
Pendulum/lever device, Veljko Milkovic	4 - 27
Phase-Lock-Loop water-splitting circuit	10 - 62
Plasma arc electrolysis patent, Ruggero Santilli	A - 754
Power System for Caravans, Mead and Holmes	14 - 20
Power tube, Edwin Gray	5 - 81
Pulse-charging system patent, John Bedini	A - 456
Pulsed flywheel generator, Jacob Bitsadze	4 - 9
Pulsed flywheel generator, Chas Campbell	4 - 4
Pulsed flywheel generator, John Bedini	4 - 11
Pulsed flywheel generator, Jim Watson	4 - 7
Pulsed flywheel generator, Lawrence Tseung	2 - 48
Pyramid, James Brock	9 - 15
Pyramid, Joseph H. Cater	9 - 29
Pyramid, Les Brown	9 - 22
Pyramid, Paulo and Alexandra Correa	11 - 15
Pyramid, Peter Grandics	9 - 21
Pyramid, Thomas Trawoeger	9 - 3
Radium power generation, Nikola Tesla	11 - 2
RF aerial to DC power, Raymond Phillips	7 - 33
Raising DC motor efficiency	2 - 55
Ram Implosion Wing, Robert Patterson	10 - 109
Ram Pump	14 - 57
Refrigeration through heating, Albert Einstein	14 - 64
Romag generator, Magnetic Energy	13 - 6
RotoVerter, Hector Torres	2 - 37
Screened transformer, Joseph Boyd	3 - 75
Searle Effect Device, John R. R. Searle	11 - 32
Self-powered water-jet electrical generator, James Hardy	2 - 25
Self-powered water-jet electrical generator, James Hardy	4 - 12
Self-powered water-jet electrical generator, James Hardy	8 - 47
Self-powered water-jet electrical generator, James Hardy	2 - 25
Self-powered electrical generator, Nilson Barbosa and Cleriston Leal	5 - 20
Self-powered electrical generator, Carlos Benitez	5 - 20
Self-powered electrical generator, Joseph H Cater	5 - 103
Self-powered electrical generator patent, Molina Martinez	A - 100
Self-powered electrical generator patent, Tariel Kapanadze	3 - 91
Self-powered electrical generator, Stephan W. Leben	3 - 65
Self-powered electrical generator patent, William Barbat	A - 164
Seventy-year battery patent, Colman/Seddon-Gillespie	A - 83
Smack's Booster, Eletrik	10 - 17
Solar ovens, BYU	14 - 21
Solar panels	14 - 66
Solar Still Water-makers	14 - 47
Spiral electrolyser patent, Shigeta Hasebe	A - 719
Stromerzeuger, Hans Coler	13 - 60
Stromerzeuger, Hans Coler	9 - 1
Tesla Coil, Correas	11 - 15
Tesla Switch, Nikola Tesla	5 - 6
Tesla Switch, Nikola Tesla	6 - 35
Testatika, Paul Baumann	13 - 1
Toroidal Power Unit, Bob Boyce	5 - 46
Turbine, Michael Eskeli	8 - 28
Ultrasonic hydrogen generator	13 - 46
Very high output ceramic solar devices patent, Philip Brody	A - 298
Vortex Fuel Reformers	10 - 116
Vortex tube	8 - 21
VTA, Floyd Sweet	3 - 66
VTA, Floyd Sweet	5 - 100
VTA, Floyd Sweet	A - 1196
Waste spark handling	10 - 70
Water Acoustic Pump, Toribio Bellocq	14 - 54
Water Acoustic Pump, Richard Dickinson	14 - 56
Water Acoustic Pump, Arthur Bentley	14 - 56
Water carburettor patent, Charles Garrett	A - 740

Water clusters, Moray B. King	A - 740
Water-engine patent application, Juan Agüero	A - 823
Water Fuel Cell, Dr Scott Cramton	10 - 53
Water Fuel Cell, Dave Lawton.	5 - 4
Water Fuel Cell, Dave Lawton.	10 - 34
Water fuel generator patent CA 2,067,735, Stanley Meyer	A - 659
Water Fuel patent 4,936,961, Stanley Meyer.	A - 620
Water-jet self-powered generator, James Hardy	2 - 25
Water-jet self-powered generator, James Hardy	8 - 47
Water-maker, Calice Courneya	14 - 55
Water-maker, Elmer Grimes.	14 - 55
Water-makers.	14 - 47
Water Heater, Peter Davey	14 - 14
Water-powered car patent, Stephen Horvath	A - 830
Water-Powered Generator, William McDavid	14 - 17
Water-Powered Generator, William McDavid	A - 1233
Water-splitting cell patent, Christopher Eccles.	A - 857
Water-splitting patent application 2005/0246059, Stephen Meyer	A - 680
Water-splitting patent 4,392,230, Henry Puharich.	A - 689
Water vapour injection systems.	10 - 107
Water injection systems, Stan Meyer	10 - 89
WFC control circuitry patent WO 92/07861, Stanley Meyer	A - 670
Wind Generator, Dan Bartmann and Dan Fink.	14 - 16
Wind Generator, Frank Herbert	14 - 18
Wind-Powered Generator, William McDavid	14 - 17
Wind-Powered Generator, William McDavid	A - 1233
Wind Power Storage System, Claude Mead and William Holmes	A - 1021
Wire sizes and capacities	A -1
ZPE to electricity conversion patent, Mead-Nachamkin	A - 603

Alphabetical Index of People

Adams, Robert	2 - 1
Adams, Robert	A - 148
Aguero, Juan	A - 823
Alexander, Robert	A - 228
Al-Hossary, Amr	4 - 27
Al-Mayahi, Abdulsalam	4 - 23
Ainslie, Rosemary	5 - 102
An, Jon Sok	A - 87
Andrews, Roger	6 - 3
Annis, Theodore	3 - 28
Ascanius, Jes	11 - 3
Aspden, Harold	11 - 3
Aspden, Harold	A - 148
Barbat, William	A - 164
Barbosa, Nilson	3 - 28
Bartmann, Dan	14 - 16
Baumann, Paul	13 - 1
Beardon, Tom	13 - 48
Bearden, Tom	A - 411
Beck, Bob	11 - 88
Beck, Bob	12 - 44
Bedini, John	4 - 11
Bedini, John	5 - 4
Bedini, John	6 - 2
Bedini, John	A - 434
Bedini, John	A - 445
Bedini, John	A - 456
Bellocq, Toribio	14 - 55
Benitez, Carlos	5 - 20
Bentley, Arthur	14 - 55
Bitsadze, Jacob	4 - 9
Borderland Science	13 - 5
Blue, Archie	10 - 127
Blue, Archie	A - 748
Boyce, Bob	5 - 46
Boyce, Bob	10 - 33
Boyd, Joseph	3 - 75
Brady, Mike	1 - 55
Brady, Mike	A - 1107
Breaux, Onezime	7 - 67
Brinkley, William	13 - 44
Britt, Robert	8 - 28
Britt, Robert	A - 1186
Brock, James	9 - 16
Brody, Philip	A - 298
Brown, Les	9 - 23
Bundock, Jim	13 - 37
Byzehr, Joseph	4 - 9
Caggiano, Allen	10 - 111
Cahill, Arthur	8 - 34
Callanan, Ossie	6 - 18
Campbell, Chas	4 - 4
Cater, Joseph H.	5 - 93
Cater, Joseph H.	5 - 103
Cater, Joseph H.	9 - 29
Cater, Joseph H.	9 - 69
Cater, Joseph H.	11 - 85
Chambers, Stephen	A - 725
Chang, Chak	A - 764
Clem, Richard	8 - 23
Coe, Graham	9 - 14
Cole, Marvin	5 - 81
Cole, Ron	6 - 40

Coler, Hans	13 - 60
Coler, Hans	9 - 1
Colman, Harold.	3 - 41
Colman, Harold.	A - 83
Cook, Daniel	11 - 51
Cornish, Francois	13 - 45
Correa, Paulo and Alexandra	11 - 15
Correa, Paulo and Alexandra	A - 561
Cotterell, Maurice	11 - 22
Cramton, Dr Scott	10 - 53
Davey, Peter	14 - 14
Davidson, Dan	A - 427
Davson, Cryil	11 - 60
Deyo, Harold	7 - 40
Diamanti, Gabriele	14 - 50
Dickinson, Richard.	14 - 56
Dmitriev, Mikhail	4 - 18
Drbal, Karel	9 - 7
Eberly, Patrick	3 - 61
Eccles, Christopher	A - 857
Ecklin, John W.	1 - 4
Einstein, Albert	14 - 64
Electrodyne Corporation	5 - 5
EnergeticForum	10 - 92
Eskeli, Michael	11 - 53
Eskeli, Michael	8 - 28
EVGRAY, Yahoo forum.	2 - 31
Ewert, Ted.	10 - 99
Ewing, Harold.	A - 56
Faraday, Michael.	13 - 4
Fecera, Frank.	A - 2
Figuera, Clemente	3 - 8
Fink, Dan	14 - 16
Flynn, Charles	1 - 15
Flynn, Charles	3 - 1
Flynn, Charles	A - 338
Flynn, Charles	A - 992
Ford, Walter	5 - 54
Frenette, Eugene	14 - 10
Garrett, Charles	10 - 126
Gadgetmall	5 - 62
Garrett, Charles	A - 740
Giannopoulos, Nikanor	3 - 73
Goldie, Charles.	7 - 50
Grandics Peter	9 - 21
Gray, Edwin	5 - 81
Gray, Edwin	A - 119
Gray, Edwin	A - 142
Gray, Edwin	A - 1046
Grimes Elmer.	14 - 54
Gritskevitch, Dr Oleg	5 - 104
Gunderson, Graham	A - 1038
Hardy, James.	2 - 25
Hardy, James.	4 - 12
Hardy, James.	8 - 47
Hasebe, Shigeta	A - 719
Hatem, Raoul.	2 - 46
Hayasaka, Shigeaki	A - 236
Heath, Brian.	6 - 26
Heins, Thane	3 - 3
Herbert, Frank	14 - 17
Hohl, Dietmar	1 - 29
Holdgate, Ed	10 - 33
Holmes, William	14 - 29
Holmes, William	A - 1021

Horvath, Stephen	A - 830
Hubbard, Alfred	5 - 90
Hyde, William	11 - 76
Hydrogen Garage	10 - 34
Ighina, Pier Luigi	9 - 31
Imhotep	6 - 25
Imhotep	6 - 28
Imris, Pavel	3 - 67
Imris, Pavel	A - 74
Ivanov, Valeri	13 - 47
Jamison, Larry	A - 252
Jines, John	1 - 11
Johnson, Howard	1 - 5
Johnson, Howard	A - 46
Kalfaian, Meguer	A - 1210
Kapanadze, Tariel	3 - 91
Kapanadze, Tariel	5 - 53
Kawai, Teruo	2 - 23
Kawai, Teruo	A - 259
Kelly, D. A.	13 - 1
Kelly, D. A.	1 - 54
Kelly, D. A.	A - 1117
Kenny, James	13 - 48
Kim, Sang Nam.	14 - 7
King, Moray B.	7 - 20
King, Moray B.	10 - 122
Kljajic, Dragan	7 - 12
Knight, Ronald	6 - 5
Kromrey, Raymond	2 - 15
Krupa, Robert.	10 - 105
Kundel, Stephen	1 - 12
Kwok, James	4 - 37
Lafonte, Butch	11 - 35
'Lasersaber'	5 - 79
Lawton, Dave	13 - 50
Lawton, Dave	5 - 4
Lawton, Dave	10 - 34
Lawton, Dave	11 - 33
Leal, Cleriston	3 - 28
Leben, Stephan W.	3 - 65
Le May, D.	7 - 54
Lindemann, Peter	2 - 55
Lindemann, Peter	10 - 94
Lisac, Bozidar.	5 - 37
Lowrie, Peter	10 - 95
Luciano, Murilo	4 - 28
Lyne, William	13 - 7
Mace, Yves	3 - 70
Martinez, Molina	A - 100
Maynard, Roger	10 - 107
McFreey, William.	3 - 96
McKay, Mark	A - 1046
McQueen, Jesse	13 - 18
Mead, Claude.	14 - 20
Mead, Claude.	A - 1021
Mead, Franklin	A - 603
Meyer, Michel.	3 - 70
Meyer, Stanley	3 - 103
Meyer, Stanley	10 - 84
Meyer, Stanley	A - 620
Meyer, Stanley	A - 627
Meyer, Stanley	A - 637
Meyer, Stanley	A - 642
Meyer, Stanley	A - 659
Meyer, Stanley	A - 670

Meyer, Stanley	A - 680
Meyers, Roy	A - 524
Milkovic, Veljko	4 - 19
Molina-Martinez, Alberto	5 - 89
Moller, Nikolas	13 - 9
Moore, Kenneth	13 - 48
Moore, Dr. Terry	11 - 30
Moray, Thomas Henry	7 - 14
Mourier, Georges	2 - 27
Nachamkin, Jack	A - 603
Naudin, Jean-Louis	13 - 4
Neal, Bob	8 - 1
Neal, Bob	A - 1126
Nelson, Carl	A - 470
Newberry, Ivor	A - 940
Newman, Joseph	11 - 40
Newman, Joseph	A - 280
Nobel, Joe	9 - 35
Ogle, Thomas	A - 955
Ognyanov, Michael	A - 113
Paine, Henry	14 - 7
Paine, Henry	A - 901
Papp, Josef	8 - 25
Papp, Josef	A - 1153
Patrick, Stephen	13 - 48
Patterson, Robert	10 - 111
Perkins, Eugene	14 - 10
Phillips, Raymond Snr.	7 - 33
Plauston, Hermann	7 - 30
Plauston, Hermann	A - 485
Pogue, Charles	A - 919
Pogue, Charles	A - 927
Pogue, Charles	A - 932
Porter, Art	2 - 54
Prentice, Frank	5 - 1
Pugh, Ron	6 - 6
Puharich, Henry	A - 689
Quirey, David	A - 689
Rayburn, Lawrence	7 - 38
Reardon, John	A - 196
Ribero, Renato	4 - 50
Robertson, Scott	8 - 4
Rogers, Leroy	8 - 6
Rogers, Leroy	A - 1132
Rothman Technologies	13 - 42
Santilli, Ruggero	A - 754
Schappeller, Karl	11 - 60
Schwartz, Harold	A - 949
Scott, John	8 - 48
Searle, John R. R.	11 - 32
Seddon-Gillespie, Ronald	3 - 71
Seddon-Gillespie, Ronald	A - 83
Shelton, Robert	A - 945
Silverhealtheu	3 - 63
Simpson, Dale	4 - 21
Smith, Donald Lee	3 - 70
Smith, Donald Lee	5 - 52
Soukup, George	1 - 26
Spence, Geoffrey	A - 213
Spiros, Spiro	A - 864
Steorn	1 - 24
Stevens, Peter	9 - 14
Sweet, Floyd	3 - 66
Sweet, Floyd	5 - 100
Sweet, Floyd	A - 1196

Szilard, Leo	14 - 60
Teal, Ben	4 - 5
Tesla, Nikola	5 - 6
Tesla, Nikola	5 - 76
Tesla, Nikola	7 - 1
Tesla, Nikola	11 - 1
Tesla, Nikola	11 - 17
Teslonian, Mr	14 - 4
Tewari, Paramahansa	13 - 6
TheGuru2You.	3 - 65
Torres, Hector	2 - 37
Tracy, Robert	1 - 9
Trawoeger, Thomas	9 - 3
Tseung, Lawrence	2 - 48
Tseung, Lawrence	3 - 1
Tseung, Lawrence	4 - 1
Tseung, Lawrence	5 - 56
Tucker, Oliver.	A - 952
UFOpolitics	2 - 55
UFOpolitics	3 - 97
UFOpolitics	6 - 45
Utkin, Vladimir	5 - 53
Valera, Cherepanov	5 - 51
Van Valkenburg, Eber.	8 - 23
Van Valkenburg, Eber.	A - 1148
Volfson, Boris.	A - 904
Wang, ShenHe	1 - 1
Watson, Jim.	4 - 11
Weir, Richard	A - 470
West, Zach	10 - 18
Willis, Richard	3 - 62
Willis, Richard	A - 1028
Wilson, Mr.	4 - 10
Yildiz, Muammer	13 - 11
Yildiz, Muammer	1 - 35
Zbikowski, Jerzy	4 - 16
Zigouras, Paul	10 - 129

A Practical Guide to 'Free-Energy' Devices

Overview

This document contains most of what I have learned about this subject after researching it for a number of years. I am not trying to sell you anything, nor am I trying to convince you of anything. When I started looking into this subject, there was very little useful information and any that was around was buried deep in incomprehensible patents and documents. My purpose here is to make it easier for you to locate and understand some of the relevant material now available. What you believe is up to yourself and none of my business. Let me stress that almost all of the devices discussed in the following pages, are devices which I have not personally built and tested. It would take several lifetimes to do that and it would not be in any way a practical option. Consequently, although I believe everything said is fully accurate and correct, you should treat everything as being "hearsay" or opinion.

Some time ago, it was commonly believed that the world was flat and rested on the backs of four elephants and that when earthquakes shook the ground, it was the elephants getting restless. If you want to believe that, you are fully at liberty to do so, however, you can count me out as I don't believe that.

The Wright brothers were told that it was impossible for aeroplanes to fly because they were heavier than air. That was a commonly believed view. The Wright brothers watched birds flying and since, without question, birds are considerably heavier than air, it was clear that the commonly held view was plain wrong. Working from that realisation, they developed aeroplanes which flew perfectly well.

The years passed, and the technology started by the Wright brothers and their careful scientific measurements and well-reasoned theory, advanced to become the "science" of aeronautics. This science was used extensively to design and build very successful aircraft and "aeronautics" gained the aura of being a "law".

Unfortunately, somebody applied aeronautic calculations to the flight of bumblebees and discovered that according to aeronautics, bumblebees couldn't possibly fly as their wings could not generate enough lift to get them off the ground. This was a problem, as it was perfectly possible to watch bees flying in a very competent manner. So, the "laws" of aeronautics said that bees can't fly, but bees actually **do** fly.

Does that mean that the laws of aeronautics were no use? Certainly not - those "laws" had been used for years and proved their worth by producing excellent aircraft. What it did show was that the "laws" of aeronautics did not yet cover every case and needed to be extended to cover the way that bees fly, which is through lift generated by turbulent airflow.

It is **very** important to realise that what are described as scientific "laws" are just the best working theories at the present time and it is virtually certain that those "laws" will have to be upgraded and extended as further scientific observations are made and further facts discovered. Let's hope those four elephants don't get restless before we have a chance to learn a bit more!

Introduction

It should be stressed at this point, that this material is intended to provide you with information and only that. If you should decide, on the basis of what you read here, to build some device or other, you do so solely and entirely at your own risk and on your own responsibility. For example, if you build something in a heavy box and then drop it on your toe, then that is completely your own responsibility (you should learn to be more careful) and nobody other than yourself is in any way liable for your injury, or any loss of income caused while your toe is recovering. Let me amplify that by stating that I do not warrant that any device or system described in this document works as described, or in any other way, nor do I claim that any of the following information is useful in any way or that any device described is useful in any way or for any purpose whatsoever. Also, let me stress that I am not encouraging you to actually construct any device described here, and the fact that very detailed construction details are provided, must not be interpreted as my encouraging you to physically construct any device described in this document. You are welcome to consider this a work of fiction if you choose to do so.

I apologise if this presentation seems very elementary, but the intention is to make each description as simple as possible so that everybody can understand it, including people whose native language is not English. If you are not familiar with the basic principles of electronics, then please read the simple step-by-step electronics tutorial in Chapter 12 which is intended to help complete beginners in the subject.

At this point in time - the early years of the twenty-first century - we have reached the point where we need to realise that some of the “laws” of science do not cover every case, and while they have been very useful in the past, they do need to be extended to cover some cases which have been left out until now.



For example, suppose a bank robber broke into a bank and stole all of the cash there. How much could he take? Answer: “every coin and every note”. The limit is the sum total of all cash in the building. This is what the “Law” of Conservation of Energy is all about. What it says is very simple – you can’t take out any more than there is there in the beginning. That seems pretty straightforward, doesn’t it?

As another example, consider a glass tumbler filled completely with water. Using common sense, tell me, how much water can be poured out of the glass? For the purposes of this illustration, please take it that temperature, pressure, gravity, etc. all remain constant for the duration of the experiment.

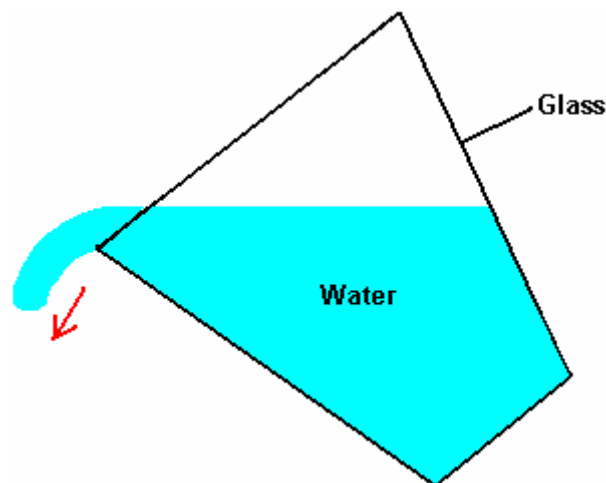

The answer is: “the exact volume contained inside the tumbler”. Agreed. This is what present day science says. To be strictly accurate, you will never be able to pour all of the water out as a small amount will remain, wetting the inside of the glass. Another way of putting this is to say that the “efficiency” of the pouring operation is not 100%. This is typical of life in general, where very few, if any, actions are 100% efficient.

So, are we agreed with current scientific thinking then – the maximum amount of water which can pour out of the tumbler is the total volume inside the tumbler? This seems simple and straightforward, doesn’t it? Science thinks so, and insists that this is the end of the story, and nothing else is possible. This arrangement is called a “closed system” as the only things being considered are the glass, the water and gravity.

Well, unfortunately for current scientific thinking, this is not the only possible situation and “closed systems” are almost unknown in the real world. Mostly, assumptions are made that the effects of anything else around will cancel out and add up to a net zero effect. This is a very convenient theory, but unfortunately it has no basis in reality.

Let’s fill our glass with water again and begin to pour it out again, but this time we position it underneath a source of flowing water:

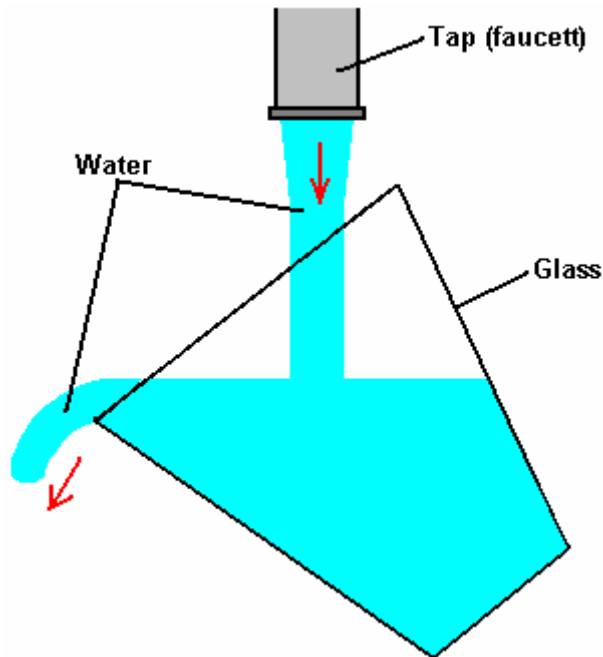

So, now, how much water can be poured out of the tumbler? Answer: “millions of times the volume of the tumbler”. But hang on a moment, haven’t we just said that the absolute limit of water poured from the tumbler has to be the volume inside the tumbler? Yes, that’s exactly what we said, and that is what current science teaching says. The bottom line here is that what current science says does in fact hold true for most of the time, but there are cases where the basic assumption of it being a “closed system” is just not true.

One popular misconception is that you can’t get more energy out of a system than you put into it. That is wrong, because the sentence was worded carefully. Let me say it again and this time, emphasise the key words: “**you** can’t get more energy out of a system than **you** put into it”. If that were true, then it would be impossible to sail a yacht all the way around the world without burning any fuel, and that has been done many times and none of the driving energy came from the crews. If it were true, then a grain mill driven by a waterwheel would not be able to produce flour as the miller certainly does not push the millstones around himself. If that were true, then nobody would build windmills, or construct solar panels, or tidal power stations.

What the statement should say is “more energy can’t be taken out of a system than is put into it or is already in it” and that is a very different statement. When sailing a yacht, the wind provides the driving force which makes the trip possible. Notice that, it is the environment providing the power and not the sailors. The wind arrived without them having to do anything about it, and a lot less than 100% of the wind energy reaching the yacht actually becomes forward thrust, contributing to the voyage. A good deal of the energy arriving at the yacht ends up stretching the rigging, creating a wake, producing noise, pushing the helmsman, etc. etc. This idea of no more energy coming out of a system than goes into it, is called “The Law of Conservation of Energy” and it is perfectly right, in spite of the fact that it gets people confused.

“Free-Energy Devices” or “Zero-Point Energy Devices” are the names applied to systems which appear to produce a higher output power than their input power. There is a strong tendency for people to state that such a system is not possible since it contravenes the Law of Conservation of Energy. It doesn’t. If it did, and any such system was shown to work, then the “Law” would have to be modified to include the newly observed fact. No such change is necessary, it merely depends on your point of view.

For example, consider a crystal set radio receiver:

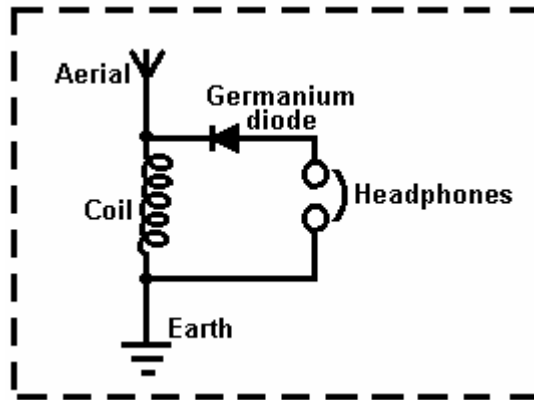

Looking at this in isolation, we appear to have a free-energy system which contradicts the Law of Conservation of Energy. It doesn't, of course, but if you do not view the whole picture, you see a device which has only passive components and yet which (when the coil is of the correct size) causes the headphones to generate vibrations which reproduce recognisable speech and music. This looks like a system which has no energy input and yet which produces an energy output. Considered in isolation, this would be a serious problem for the Law of Conservation of Energy, but when examined from a common sense point of view, it is no problem at all.

The whole picture is:

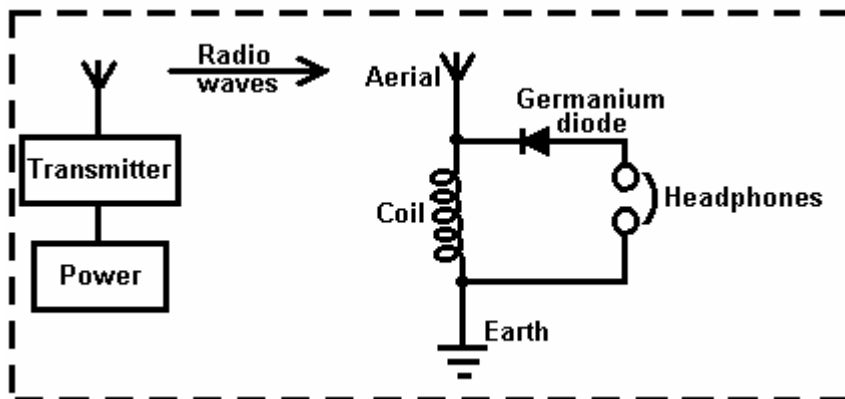

Power is supplied to a nearby transmitter which generates radio waves which in turn, induce a small voltage in the aerial of the crystal set, which in turn, powers the headphones. The power in the headphones is far, far less than the power taken to drive the transmitter. There is most definitely, no conflict with the Law of Conservation of Energy. However, there is a quantity called the "Coefficient Of Performance" or "COP" for short. This is defined as the amount of power coming out of a system, divided by the amount of power that **the operator** has to put into that system to make it work. In the example above, while the **efficiency** of the crystal set radio is well below 100%, the **COP** is greater than 1. This is because the owner of the crystal radio set does not have to supply any power at all to make it work, and yet it outputs power in the form of sound. As the input power from the user, needed to make it work is zero, and the COP value is calculated by dividing the output power by this zero input power, the COP is actually infinity. **Efficiency** and **COP** are two different things. Efficiency can never exceed 100% and almost never gets anywhere near 100% due to the losses suffered by any practical system.

As another example, consider an electrical solar panel:

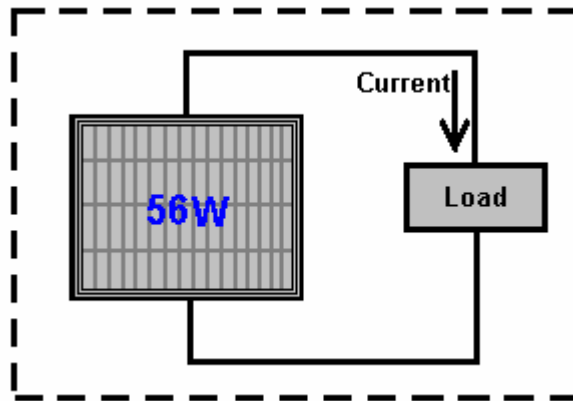

Again, viewed in isolation, this looks like (and actually is) a Free-Energy device if it is set up out of doors in daylight, as current is supplied to the load (radio, battery, fan, pump, or whatever) without the user providing any input power. Again, Power Out with no Power In. Try it in darkness and you find a different result because the whole picture is:

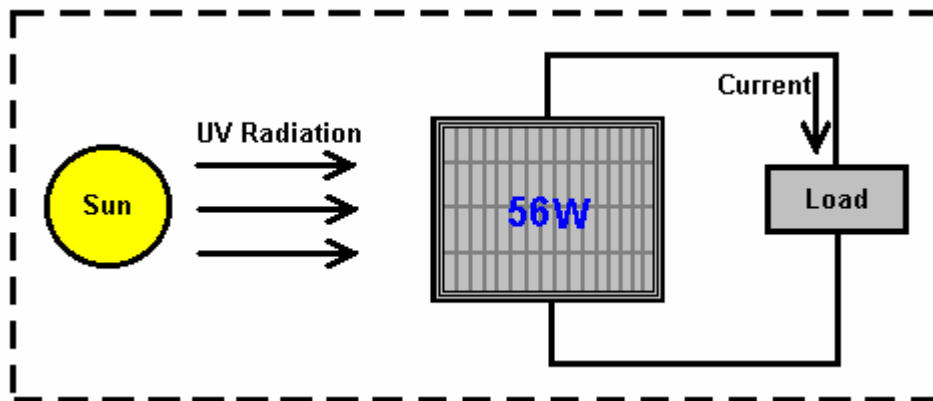

The energy which powers the solar panel comes from the sun.. Only some 17% of the energy reaching the solar panel is converted to electrical current. This is most definitely not a contravention of the Law of Conservation of Energy. This needs to be explained in greater detail. The Law of Conservation of Energy applies to closed systems, and only to closed systems. If there is energy coming in from the environment, then the Law of Conservation of Energy just does not apply, unless you take into account the energy entering the system from outside.

People sometimes speak of "over-unity" when talking about the efficiency of a system. From the point of efficiency, there is no such thing as "over-unity" as that would mean that more power was coming out of the system than the amount of power entering the system. Our trusty bank robber mentioned above would have to take out of the bank vault, more money than was actually in it, and that is a physical impossibility. There are always some losses in all practical systems, so the efficiency is always less than 100% of the power entering the system. In other words, the efficiency of any practical system is always under unity.

However, it is perfectly possible to have a system which has a greater power output than the power input which **we** have to put into it to make it work. Take the solar panel mentioned above. It has a terribly low efficiency of about 17%, **but**, we don't have to supply it with any power to make it work. Consequently, when it is in sunlight, it's Coefficient Of Performance ("COP") is it's output power (say, 50 watts) divided by the input power needed to make it work (zero watts) which is infinity. So, our humble, well-known solar panel has terrible efficiency of 17% but at the same time it has a COP of infinity.

It is now generally accepted that "Dark Matter" and "Dark Energy" form more than 80% of our universe. There is nothing sinister about the adjective "Dark" as in this context, it merely means that we cannot see it. There are many useful things which we utilise, which we can't see, for example, radio waves, TV signals, magnetism, gravity, x-rays, etc. etc.

The fact of the matter is, that we are sitting in a vast field of energy which we can't see. This is the equivalent of the situation for the crystal set shown above, except that the energy field we are in is very, very much more powerful than the radio waves from a radio transmitter. The problem is, how to tap the energy which is freely available all around us, and get it to do useful work for us. It can definitely be done, but it is not easy to do.

Some people think that we will never be able to access this energy. Not very long ago, it was widely believed that nobody could ride a bicycle faster than 15 miles per hour because the wind pressure on the face of the rider would suffocate him. Today, many people cycle much faster than this without suffocating - why? - because the original negative opinion was wrong.

Not very long ago, it was thought that metal aircraft would never be able to fly because metal is so much heavier than air. Today, aircraft weighing hundreds of tons fly on a daily basis. Why? - because the original negative opinion was not correct.

It is probably worth while, at this point, to explain the basics of Zero-Point Energy. The experts in Quantum Mechanics refer to how the universe operates as "Quantum Foam". Every cubic centimetre of "empty" space is seething with energy, so much in fact, that if it were converted using Einstein's famous equation $E = mc^2$ (that is Energy = Mass x a very big number), then it would produce as much matter as can be seen by the most powerful telescope. There is actually nothing "empty" about space. So why can't we see anything there? Well, you can't actually see energy. All right then, why can't you measure the energy there? Well, two reasons actually, firstly, we have never managed to design an instrument which can measure this energy, and secondly, the energy is changing direction incredibly rapidly, billions and billions and billions of times each second.

There is so much energy there, that particles of matter just pop into existence and then pop back out again. Half of these particles have a positive charge and half of them have a negative charge, and as they are evenly spread out in three-dimensional space, the overall average voltage is zero. So, if the voltage is zero, what use is that as a source of energy? The answer to that is "none" if you leave it in it's natural state. However, it is possible to change the random nature of this energy and convert it into a source of unlimited, everlasting power which can be used for all of the things we use mains electricity for today - powering motors, lights, heaters, fans, pumps, ... you name it, the power is there for the taking.

So, how do you alter the natural state of the energy in our environment? Actually, quite easily. All that is needed is a positive charge and a negative charge, reasonably near each other. A battery will do the trick, as will a generator, as will an aerial and earth, as will an electrostatic device like a Wimshurst machine. When you generate a **Plus** and a **Minus**, the quantum foam is affected. Now, instead of entirely random plus and minus charged particles appearing everywhere, the **Plus** which you created gets surrounded by a sphere of minus charge particles popping into existence all around it. Also, the **Minus** which you created, gets surrounded by a spherical-shaped cloud of plus-charge particles popping into existence all around it. The technical term for this situation is "**broken symmetry**" which is just a fancy way of saying that the charge distribution of the quantum foam is no longer evenly distributed or "symmetrical". In passing, the fancy technical name for your **Plus** and **Minus** near each other, is a "**dipole**" which is just a techno-babble way of saying "two poles: a plus and a minus" - isn't jargon wonderful?

So, just to get it straight in your mind, when you make a battery, the chemical action inside the battery creates a Plus terminal and a Minus terminal. Those poles actually distort the universe around your battery, and causes vast streams of energy to radiate out in every direction from each pole of the battery. Why doesn't the battery run down? Because the energy is flowing from the environment and not from the battery. If you were taught basic physics or electrical theory, you will probably have been told that the battery used to power any circuit, supplies a stream of electrons which flows around the circuit. Sorry Chief - it just ain't like that at all. What really happens is that the battery forms a "dipole" which nudges the local environment into an unbalanced state which pours out energy in every direction, and some of that energy from the environment flows around the circuit attached to the battery. The energy does **not** come from the battery.

Well then, why does the battery run down, if no energy is being drawn from it to power the circuit? Ah, that is the really silly thing that we do. We create a closed-loop circuit (because that's what we have always done) where the current flows around the circuit, reaches the other battery terminal and immediately destroys the battery's "dipole". Everything stops dead in it's tracks. The environment becomes symmetrical again, the massive amount of readily available free-energy just disappears and you are back to where you started from. **But**, do not despair, our trusty battery immediately creates the Plus and Minus terminals again and the process starts all over again. This happens so rapidly that we don't see the breaks in the operation of the circuit and it is the continual recreation of the dipole which causes the battery to run down and lose it's power. Let me say it again, the battery does **not** supply the current that powers the circuit, it never has and it never will - the current flows into the circuit from the surrounding environment.

What we really need, is a method of pulling off the power flowing in from the environment, without continually destroying the dipole which pushes the environment into supplying the power. That is the tricky bit, but it has been done. If you can do that, then you tap into an unlimited stream of inexhaustible energy, with no need to provide any input energy to keep the flow of energy going. In passing, if you want to check out the details of all of this, Lee and Yang were awarded the Nobel Prize for Physics in 1957 for this theory which was proved by experiment in that same year. This eBook includes circuits and devices which manage to tap this energy successfully.

Today, many people have managed to tap this energy but very few commercial devices are readily available for home use. The reason for this is human rather than technical. More than 10,000 Americans have produced devices or ideas for devices but none have reached commercial production due to opposition from influential people who do not want such devices freely available. One technique is to classify a device as "essential to US National Security". If that is done, then the developer is prevented from speaking to anyone about the device, even if he has a patent. He cannot produce or sell the device even though he invented it. Consequently, you will find many patents for perfectly workable devices if you were to put in the time and effort to locate them, though most of these patents never see the light of day, having been taken by the people issuing these bogus "National Security" classifications for their own use.

If you feel that this opposition to free-energy and related technology is a figment of my imagination and that the people who state that more than 40,000 free-energy device patents have already been suppressed, then please consider this extract from a 2006 reminder to Patent Office staff in America to single out all patents which have to do with free-energy and any related subjects and take those patent applications to their supervisor to be dealt with differently to all other patent applications:

B. Subject matter of special interest in TC 2800

1. **Perpetual motion machines; classes 310 and 290**
2. **Anti-gravity devices**
3. **Room temperature superconductivity; class 310**
4. **Free energy – Tachyons, etc.**
5. **Gain-Assisted Superluminal Light Propagation (faster than the speed of light); class 702, 359**
6. **Other matters that violate the general laws of physics; classes 73, 290.**
7. **Applications containing claims to subject matter which, if issued, would generate unfavorable publicity for the USPTO, class 84, 702.**
8. **Reexamination proceedings involving patents in litigation and:
The court decision/verdict is subject to review by the Supreme Court
The court decision includes high monetary awards
The technology and companies involved would likely generate high publicity**

Here "USPTO" is the United States Patent and Trademark Office, which is a privately owned commercial company run to make money for it's owners.

The purpose of this eBook is to present the facts about some of these devices and more importantly, where possible, explain the background details of why and how systems of that type function. As has been said before, it is not the aim of this book to convince you of anything, just to present you with some of the facts which are not that easy to find, so that you can make up your own mind on the subject.

The science taught in schools, colleges and universities at this time, is well out of date and in serious need of being brought up to date. This has not happened for some time now as people who make massive financial profits have made it their business to prevent any significant advance for many years now. However, the internet

and free sharing of information through it, is making things very difficult for them. What is it that they don't want you to know? Well, how about the fact that you don't have to burn a fuel to get power? Shocking, isn't it !! Does it sound a bit mad to you? Well, stick around and start doing some thinking.

Suppose you were to cover a boat with lots of solar panels which were used to charge a large bank of batteries inside the boat. And if those batteries were used to operate electric motors turning propellers which drive the boat along. If it is sunny weather, how far could you go? As far as the boat can travel while the sun is up and if the battery bank is large, probably most of the night as well. At sun-up on the next day, you can continue your journey. Oceans have been crossed doing this. How much fuel is burned to power the boat? None !! Absolutely none at all. And yet, it is a fixed idea that you have to burn a fuel to get power.

Yes, certainly, you can get power from the chemical reaction of burning a fuel - after all, we pour fuel into the tanks of vehicles "to make them go" and we burn oil in the central heating systems of buildings. But the big question is: "Do we have to?" and the answer is "No". So why do we do it? Because there is no alternative at present. Why is there no alternative at present? Because the people making incredibly large financial profits from selling this fuel, have seen to it that no alternative is available. We have been the suckers in this con trick for decades now, and it is time for us to snap out of it. Let's have a look at some of the basic facts:

Let me start by presenting some of the facts about electrolysis. The electrolysis of water is performed by passing an electric current through the water, causing it to break up into hydrogen gas and oxygen gas. This process was examined in minute detail by Michael Faraday who determined the most energy efficient possible conditions for electrolysis of water. Faraday determined the amount of electric current needed to break the water apart, and his findings are accepted as a scientific standard for the process.

We now bump into a problem which scientists are desperate to ignore or deny, as they have the mistaken idea that it contradicts the Law of Conservation of Energy – which, of course, it doesn't. The problem is an electrolyser design by Bob Boyce of the USA which appears to have an efficiency twelve times greater than Faraday's maximum possible gas production. This is a terrible heresy in the scientific arena and it gets the average "by the book" scientist very up-tight and flustered. There is no need for this worry. The Law of Conservation of Energy remains intact and Faraday's results are not challenged. However, an explanation is called for.

To start with, let me show the arrangement for a standard electrolyser system:

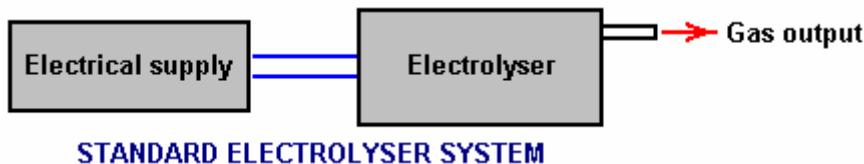

Here, current is supplied to the electrolyser by the electrical supply. The current flow causes breakdown of the water contained in the electrolyser, resulting in the amount of gas predicted by Faraday (or less if the electrolyser is not well designed and accurately built).

Bob Boyce, who is an exceptionally intelligent, perceptive and able man, has developed a system which performs the electrolysis of water using power drawn from the environment. To a quick glance, Bob's design looks pretty much like a high-grade electrolyser (which it is) but it is a good deal more than that. The practical construction and operational details of Bob's design are shown in <http://www.free-energy-info.tuks.nl/D9.pdf>, but for here, let us just consider the operation of his system in very broad outline:

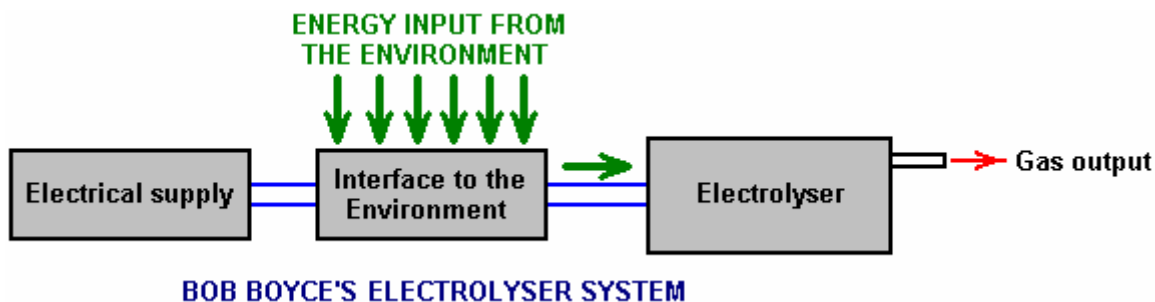

The very important distinction here is that the power flowing into the electrolyser and causing the water to break down and produce the gas output, is coming almost exclusively from the environment and **not** from the electrical supply. The main function of Bob's electrical supply is to power the device which draws energy in from the environment. Consequently, if you assume that the current supplied by the electrical supply is the whole of the

power driving the electrolyser, then you have a real problem, because, when properly built and finely tuned, Bob's electrolyser produces up to 1,200% of Faraday's maximum efficiency production rate.

This is an illusion. Yes, the electrical input is exactly as measured. Yes, the gas output is exactly as measured. Yes, the gas output is twelve times the Faraday maximum. But Faraday's work and the Law of Conservation of Energy are not challenged in any way **because** the electrical current measured is used primarily to power the interface to the environment and nearly all of the energy used in the electrolysis process flows in from the local environment and is not measured. What we can reasonably deduce is that the energy inflow from the environment is probably about twelve times the amount of power drawn from the electrical supply.

At this point in time, we do not have any equipment which can measure this environmental energy. We are in the same position as people were with electrical current five hundred years ago – there was just no equipment around which could be used to make the measurement. That, of course, does not mean that electrical current did not exist at that time, just that we had not developed any equipment capable of performing measurement of that current. Today, we know that this environmental energy exists because we can see the effects it causes such as running Bob's electrolyser, charging batteries, etc. but we can't measure it directly because it vibrates at right-angles to the direction that electrical current vibrates in. Electrical current is said to vibrate "transversely" while this zero-point energy vibrates "longitudinally", and so has no effect on instruments which respond transversely such as ammeters, voltmeters, etc.

Bob Boyce's 101-plate electrolyser produces anything up to 100 litres of gas per minute, and that rate of production is able to power internal combustion engines of low capacity. The vehicle alternator is perfectly capable of powering Bob's system, so the result is a vehicle which appears to run with water as the only fuel. This is not the case, nor is it correct to say that the engine is powered by the gas produced. Yes, it does utilise that gas when running, but the power running the vehicle is coming directly from the environment as an inexhaustible supply. In the same way, a steam engine does not run on water. Yes, it does utilise water in the process, but the power that runs a steam engine comes from burning the coal and not from the water.

The Basics of "Free-Energy":

This beginner's introduction presumes that you have never heard of free-energy before and would like an outline sketch of what it is all about, so let's begin at the beginning.

We tend to have the impression that people who lived a long time ago were not as clever as we are - after all, we have television, computers, mobile phones, games consoles, aeroplanes, But, and it is a big "but", the reason why they did not have those things is because science had not advanced far enough for those things to become possible. That did **not** mean that the people who lived before us were any less clever than we are.

For example, could you, personally, come up with an accurate calculation of the circumference of the Earth? This has to be without prior knowledge, no satellites, no astronomical information, no calculators, no computers and no experts to guide you. Eratosthenes did by observing the shadows in two wells some 800 kilometres apart. When was that? More than two thousand years ago.

You have probably heard of the geometry of Pythagoras who lived hundreds of years before Eratosthenes, and that geometry is still used in remote areas to lay out the foundations for new buildings. You have probably heard of Archimedes who worked out why things float. He lived more than two thousand years ago. So, how do those people stack up against you and me? Were they stupid people?

This is quite an important point because it demonstrates that the body of scientific information enables many things which were not thought possible in earlier times. This effect is not restricted to centuries ago. Take the year 1900. My father was a youngster then, so it is not all that long ago. It would be another three years before Orville and Wilbur Wright made their first 'heavier-than-air' flight, so there no aircraft around in 1900. There were no radio stations and most definitely, no television stations, nor would you have found a telephone inside a house. The only serious forms of information were books and periodicals or teaching establishments which relied on the knowledge of the teachers. There were no cars and the fastest form of transport for the average person was on a galloping horse.

Today, it is difficult to grasp what things were like not all that long ago, but come closer in time and look back just fifty years. Then, people researching in scientific fields had to design and build their own instruments before they ever got to experimenting in their chosen fields of knowledge. They were instrument makers, glass-blowers, metal workers, etc. as well as being scientific researchers. Nowadays there are measuring instruments of all kinds for sale ready-made. We have silicon semiconductors which they didn't have, integrated circuits, computers, etc. etc.

The important point here is the fact that advances in scientific theory have made possible many things which would have been considered quite ridiculous notions in my father's time. However, we need to stop thinking as if we already know everything there is to know and that nothing which we think of as "impossible !!" could ever happen. Let me try to illustrate this by remarking on just a few things which as recently as the year 1900 would have marked you out as a "lunatic crank", things which we take for granted today because, and only because, we are now familiar with the science behind each of these things.

Certainties in the year 1900



A metal aeroplane weighing 350 tons couldn't possibly fly - everyone knows that !!



You couldn't possibly watch someone who is a thousand miles away - talk sense !!



No ! Of course you can't speak to somebody who lives in a different country unless you visit them !



The fastest way to travel is on a galloping horse.



A machine could never beat a man at chess - be realistic !

Today, we know that these things are not just possible, but we take them for granted. We have a mobile phone in our pocket and could easily use it to talk to friends in other countries almost anywhere in the world. It would seem very strange if we could not do that any more.

We each have a television and can watch, say, a golf tournament taking place at the other side of the world. We watch in real time, seeing the result of each stroke almost as soon as the golfer does himself. Even suggesting that such a thing was possible might have got you burnt at the stake for witchcraft, not all that long ago, but not having television would seem a very strange situation for us today.

If we see a 350 ton metal Boeing 747 aircraft flying past, we would not think it to be strange in any way, let alone think it was "impossible". It is routine, casual travel at 500 mph, a speed which would have been considered to be a fantasy when my father was young. The fact that the aircraft is so heavy, is of no concern to us as we know that it will fly, and does so, routinely, every day of the year.

We take for granted, a computer which can do a million things in one second. Today, we have lost the understanding of how big "a million" is, and we know that most people are likely to lose a game of chess if they play against a computer, even a cheap chess computer.

What we need to understand is that our present scientific knowledge is far from being comprehensive and there is still a very large amount to be learned, and that things which the average person today would consider "impossible" are quite liable to be casually routine day-to-day devices in just a few years time. This is **not** because we are stupid but instead it is because our current science still has a long way to go.

The objective of this website (<http://www.free-energy-info.tuks.nl>) is to explain some of the things which current science is not teaching at the present time. Ideally, we want a device which will power our homes and cars without the need to burn a fuel of any kind. Before you get the idea that this is some new and wild idea, please remember that windmills have been pumping water, milling grain, lifting heavy loads and generating electricity for a very long time now. Water wheels have been doing similar work for a very long time and both of these devices are fuel-less.

The energy which powers windmills and water wheels comes to us via our Sun which heats air and water, causing wind and rain, feeding power to our devices. The energy flows in from our local environment, costs us nothing and will keep on coming whether we make use of it or not.

Most of the pictures of wind generators and water wheels which you will see, show devices which would take a large amount of money to set up. The title of this eBook is "The Practical Guide to Free-Energy Devices" and the

word "practical" is intended to indicate that most of the things spoken about are things which you, personally, have a reasonable chance of constructing for yourself if you decide to do so. However, while in chapter 14 there are instructions for building your own wind-powered electrical generator from scratch, pumping water uphill without using a fuel and utilising wave power at low cost, these things are subject to the weather. So, because of this, the main subject is the next generation of commercial devices, devices which do not need a fuel in order to function and power our homes and vehicles, devices which operate no matter what the weather is doing.

Perhaps I should remark at this point, that the commercial introduction of this new wave of hi-tech devices is being actively opposed by people who will lose a very large stream of revenue when it does eventually happen, as it most certainly will. For example, Shell BP which is a typical oil company, makes about US \$3,000,000 profit per hour, every hour of every day of every year, and there are dozens of oil companies. The government makes even more than that out of the operation, with 85% of the sale price of oil in the UK being government tax. No matter what they say, (and they both do like to talk "green" in order to gain popularity), neither would ever for a single moment, consider allowing the introduction of fuel-less power devices, and they have the financial muscle to oppose this new technology at every possible level.

For example, some years ago Cal-Tech in the USA spent millions proving that on board fuel reformers for vehicles would give us all better fuel economy and cleaner air. They did long-term testing on buses and cars to provide proof. They teamed up with the very large auto-parts supplier Arvin Meritor to put these new devices in production vehicles. Then "One Equity Partners" bought out Arvin Meritor's division that did all the final work to get fuel reformers put into all new vehicles. They created a new company, EMCON Technologies, and that company dropped the fuel reformer from their product line, not because it did not work, but because it **did** work. This is not "conspiracy theory" but a matter of public record.

Some years ago, Stanley Meyer, a very talented man living in America, found a very energy-efficient way of breaking water into a mixture of hydrogen gas and oxygen gas. He pushed on further and found that a vehicle engine could be run on quite a small amount of this "hydroxy" gas if it was mixed with air, water droplets and some of the exhaust gas coming from the engine. He got funding to allow him to start manufacturing retro-fit kits which would allow any car to run on water alone and not use any fossil fuel at all. You can imagine how popular that would have been with the oil companies and the government. Just after getting his funding, Stan was eating a meal at a restaurant when he jumped up, said "I've been poisoned !", rushed out into the car park and died on the spot. If Stan was mistaken, and he died of 'natural causes', then it was remarkably convenient timing for the oil companies and the government, and his retro-fit kits were never manufactured.

Even though Stan left behind many patents on the subject, until recently nobody managed to replicate his very low-power electrolyser, then Dave Lawton in Wales achieved the feat and many people have since replicated it by following Dave's instructions. More difficult still is getting an engine to run on no fossil fuel as Stan did, but recently, three men in the UK achieved just that by getting a standard petrol-engined electrical generator to run with water as the only fuel. Interestingly, this is not something which they want to pursue as they have other areas which appeal more to them. Consequently, they have no objections to sharing the practical information on what they did and the details are in chapter 10.

In very brief outline, they took a standard 5.5 kilowatt generator and delayed the spark timing by some eleven degrees, suppressed the 'waste' spark and fed the engine a mix of air, water droplets and just a small amount of hydroxy gas (measured at three litres per minute). They test-loaded the generator with four kilowatts of electrical equipment to confirm that it worked well under load, and then moved on to larger engines. This is the general style of generator which they used:



And their arrangement for running it without petrol, is shown in outline here, the full details being in chapter 10, including how to make your own high-performance electrolyser:

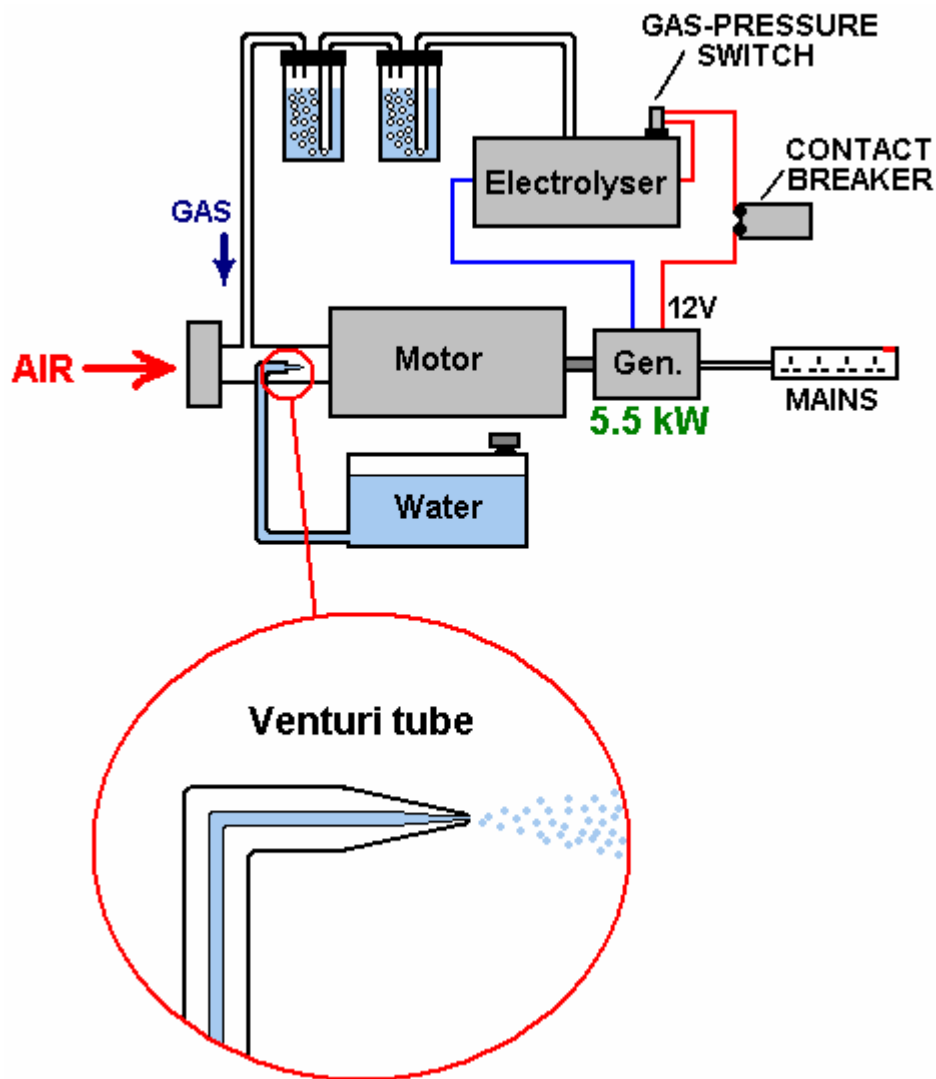

Conventional science says that it can prove mathematically that it is quite impossible to do this. However, the calculation is massively flawed in that it is not based on what is actually happening and worse still, it makes initial assumptions which are just plain wrong. Even if we were not aware of these calculations, the fact that it has been done is quite enough to show that the current engineering theory is out of date and needs to be upgraded.

Now, let us consider a device built by John Bedini, another talented man in America. He built a battery-powered motor with a flywheel on the shaft of the motor. This, of course, does not sound like startling stuff, but the crunch is that this motor ran in his workshop for more than three years, keeping its battery fully charged during that time - now that **is** startling. The arrangement is like this:

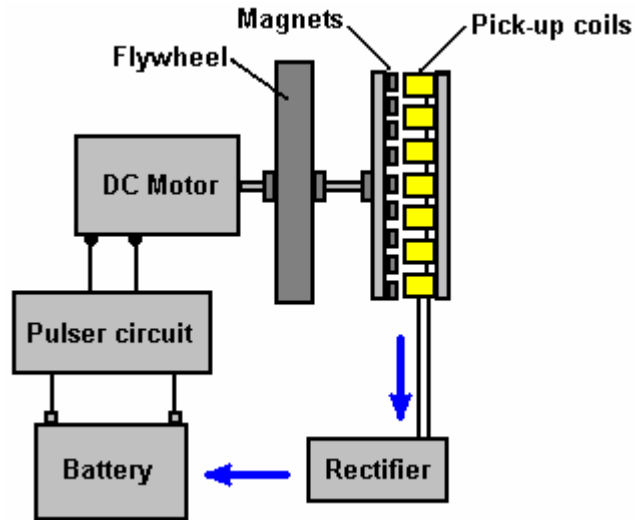

What makes this arrangement different from a standard set-up is that the battery powered motor is not connected directly to the battery but instead is fed with a rapid series of DC pulses. This has two effects. Firstly, that method of driving a motor is very efficient electrically speaking and secondly, when a flywheel is driven with a series of pulses, it picks up additional energy from the local environment.

One other unusual feature is the way that the motor shaft spins a disc with permanent magnets mounted on it. These sweep past a matching set of coils attached to a stationary board, forming an ordinary electrical generator and the resulting electrical power which is generated is converted to DC current and fed back to the driving battery, charging it and maintaining its voltage.

Standard theory says that a system like this has to be less than 100% efficient because the DC motor is less than 100% efficient (true) and the battery is well below the 100% efficient mark (true). Therefore, the conclusion is that the system cannot possibly work (false). What is not understood by conventional science is that the pulsed flywheel draws in additional energy from the local environment, showing that conventional science theory is inadequate and out of date and needs to be upgraded.

An American called Jim Watson built a much larger version of John's system, a version which was twenty feet (6 meters) long. Jim's version not only powered itself, but generated 12 kilowatts of excess electrical power. That extra 12 kilowatts of power must be a considerable embarrassment for conventional science and so they will either ignore it, or deny that it ever existed, in spite of the fact that it was demonstrated at a public seminar. This is what Jim's device looked like:

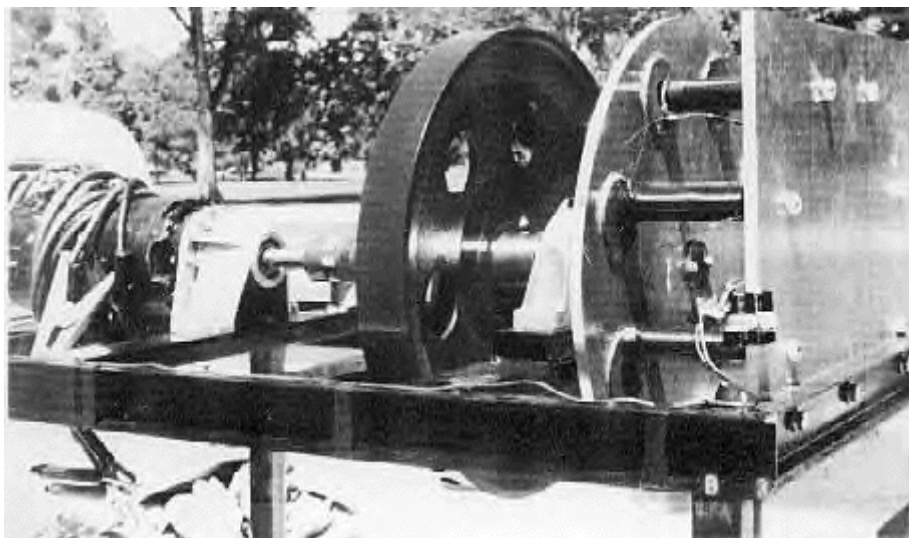

Working quite independently, an Australian called Chas Campbell, discovered the same effect. He found that if he used an AC motor plugged into the mains, that it was possible to get more work done than the amount it takes to drive the motor.



He used his motor to drive a series of shafts, one of which has a heavy flywheel mounted on it, like this:



The final shaft drives a standard electrical generator and Chas found that he could power electrical equipment from that generator, electrical mains equipment which required greater current than his mains-driven motor did.

Chas then took it one stage further and when the system was running at full speed, he switched his mains motor over from the wall socket to his own generator. The system continued to run, powering itself and driving other equipment as well.

Conventional science says that this is impossible, which just goes to show that conventional science is out of date and needs to be upgraded to cover systems like this where excess energy is flowing in from the local environment. Here is a diagram of how Chas Campbell's system is set up:

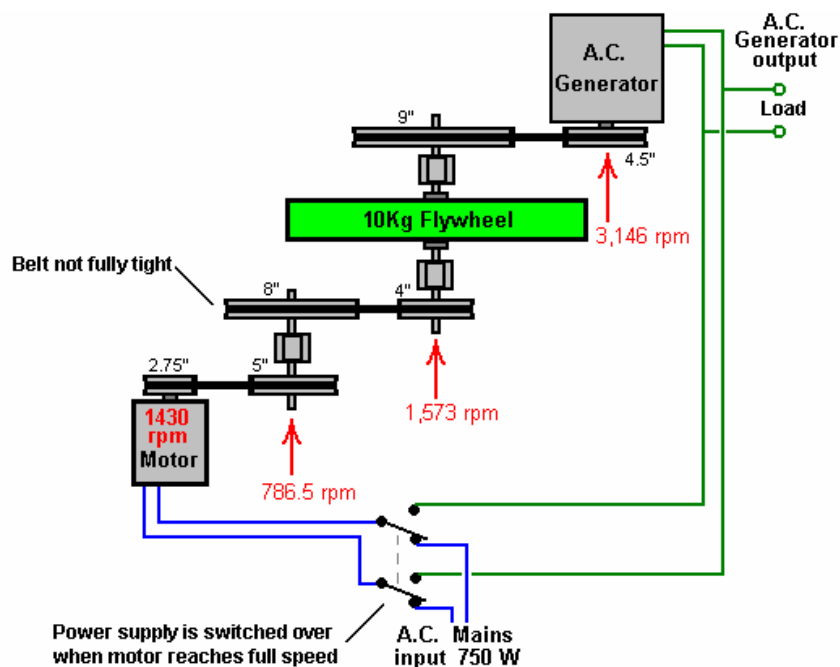

Another man has put a video on the web, showing a variation of this same principle. In his case, the flywheel is very light and has simple paddles attached around the rim of the wheel:



He then aims a powerful jet of water from a high-powered water pump, directly at the paddles, driving the wheel round with a rapid series of pulses. The shaft, on which the wheel is mounted, drives a standard electrical generator which lights an ordinary light bulb:



The really interesting part comes next, because he then unplugs the electrical supply to the water pump and switches it over to the generator which the wheel is driving. The result is that the pump powers itself and provides excess electricity which can be used to power other electrical equipment. The arrangement is like this:

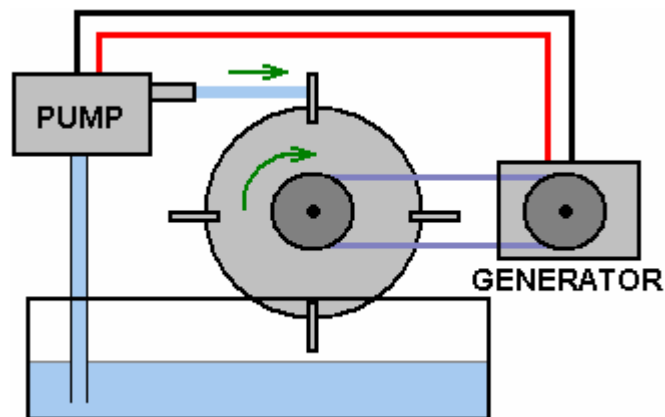

Once again, conventional science says that this is impossible, which in turn, demonstrates that conventional science is out of date and needs to be expanded to include these observed facts.

Permanent Magnets have continuous power. This should be obvious as one will support its own weight on the vertical face of a refrigerator, for years on end. Conventional science says that permanent magnets can't be used as a source of power. However, the reality is that conventional science just doesn't know the techniques necessary for extracting that power.

The New Zealander, **Robert Adams** produced a motor which appears to be, typically, 800% efficient. This, of course, is impossible according to conventional science. Robert was told that if he shared the information, he would be killed. He decided that at his age, being killed was not a major thing, so he went ahead and published all the details.

Motors driven by electrical pulses are always less than 100% efficient. The Adams motor looks like that sort of design but it is **not**. The motor power comes from the permanent magnets mounted on the rotor and not from an electrical pulse applied to the electromagnets attached to the stator. The magnets are attracted to the metal cores of the stationary electromagnets. This provides the driving power of the motor. The electromagnets are then powered just enough to overcome the backwards drag of the magnets when they have just passed by the cores of the electromagnets.

The system works like this:

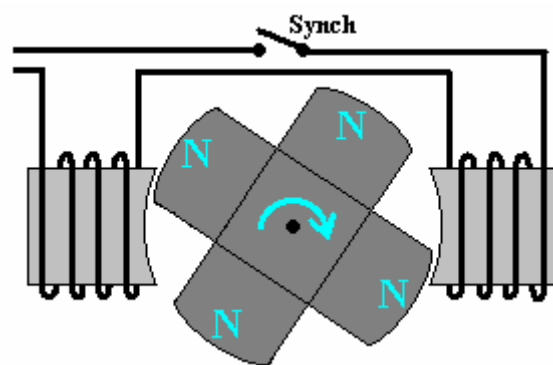

1. The magnets are attracted to the iron cores of the electromagnets, rotating the drive shaft and powering the motor.
2. The moving magnets generate electrical power in the windings of the electromagnets and this power is used to charge the driving battery.
3. When the permanent magnets reach the electromagnets, a small amount of electrical power is fed to the windings of the electromagnets in order to overcome any backward pull hindering the rotation of the drive shaft.
4. When that power supplied to the electromagnets is cut off, the Back EMF pulse is captured and used to charge the driving battery.
5. Although not shown in the diagram above, there are normally additional pick-up coils mounted round the rotor and if they are connected briefly at the right moment, they generate extra current and when they are switched off, their resulting reversed magnetic field also boosts the rotor on it's way, and that can raise the COP over 1000. One replication using this technique has an electrical input of 27 watts and a 32 kilowatt output.

When operated in this way, the Adams Motor has a power output far in excess of the input power needed to make it run. The design confuses conventional science because conventional science refuses to accept the concept of energy flow into the motor, from the local environment. This is all the more strange, considering that windmills, water wheels, hydro-electric schemes, solar panels, wave-power systems, tidal power systems and geothermal energy systems are accepted and considered perfectly normal, in spite of the fact that they all operate on energy flowing in from the local environment. It is difficult to avoid the conclusion that vested interests are working hard to prevent conventional science accepting the fact that free-energy is all around us and there for the taking. Perhaps it is the case that they want us to go on paying for fuel to burn to "make" energy to power our homes and vehicles.

Another example of magnet power being used in the design of a powerful motor comes from **Charles Flynn**. He uses a similar method of electrical screening to prevent magnetic drag hindering the drive shaft rotation. Instead of using electromagnets, Charles uses permanent magnets on both the rotor and the stator, and a flat coil of wire to create the blocking fields:

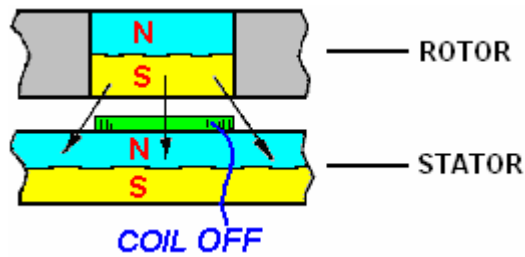

When the coil does not have current flowing through it, it does not produce a magnetic field and the South pole of the rotor magnet is attracted equally forwards and backwards by the North pole of the stator magnet. If there are two coils as shown below, and one is powered and the other is not powered, the backward pull is cancelled out and the forward pull causes the rotor to move forwards:

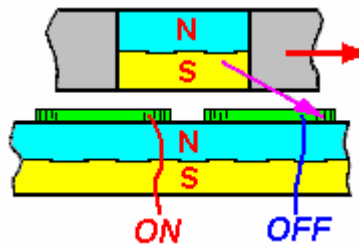

Conventional science takes a quick glance at this arrangement and proclaims that the motor efficiency has to be less than 100% because of the large electrical pulse needed to make the shaft turn. This just demonstrates a complete lack of understanding of how the motor operates. There is no "large electrical pulse" because the motor is **not** driven by electrical pulses, but instead it is driven by the attraction of many pairs of magnets, and only a very small electrical pulse is applied to cancel the backward drag as the magnets move past. To put this in context, the powerful prototype motor built by Charles ran at 20,000 rpm and the power for the coils was supplied by an ordinary 9-volt "dry-cell" battery quite incapable of supplying heavy currents.

The motor is easily made more powerful by using a stator magnet on both side of the rotor magnet, as shown here:

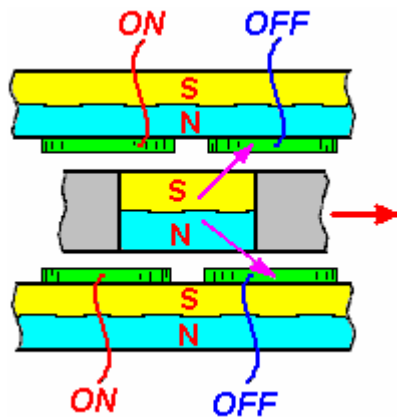

There is no real limit to the power of this motor as layer after layer of magnets can be mounted on a single drive shaft as shown here:

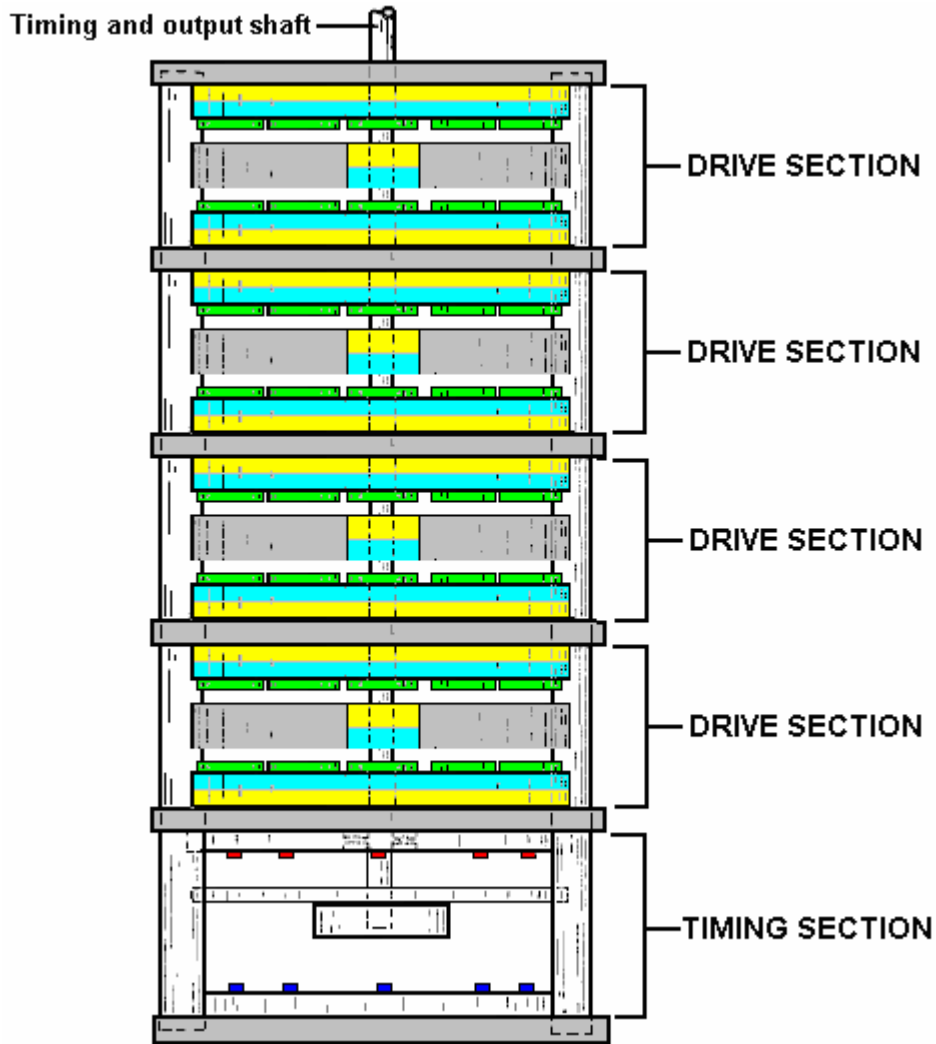

The electrical pulses to the screening coils can be synchronised by the light from Light-Emitting Diodes mounted in the timing section, shining through holes in a timing disc attached to the drive shaft of the motor. The light falling on light-dependant resistors on the other side of the disc, provide the switching for the coil-powering electricity.

An alternative method is to skip the timing section altogether and provide the synchronising pulses from an adjustable-frequency electronic pulsing circuit. To start the motor, very slow pulses are generated to get the drive shaft moving, and then the pulse rate is increased to speed the motor up. This has the advantage of providing speed control which can be useful for some applications.

Aerial systems. We are surrounded by so much energy that a simple aerial and earth connection can draw in very large amounts of electrical power from the local environment.



Thomas Henry Moray ran frequent public demonstrations during which he lit banks of light bulbs to show that useful amounts of energy could be drawn from the environment:

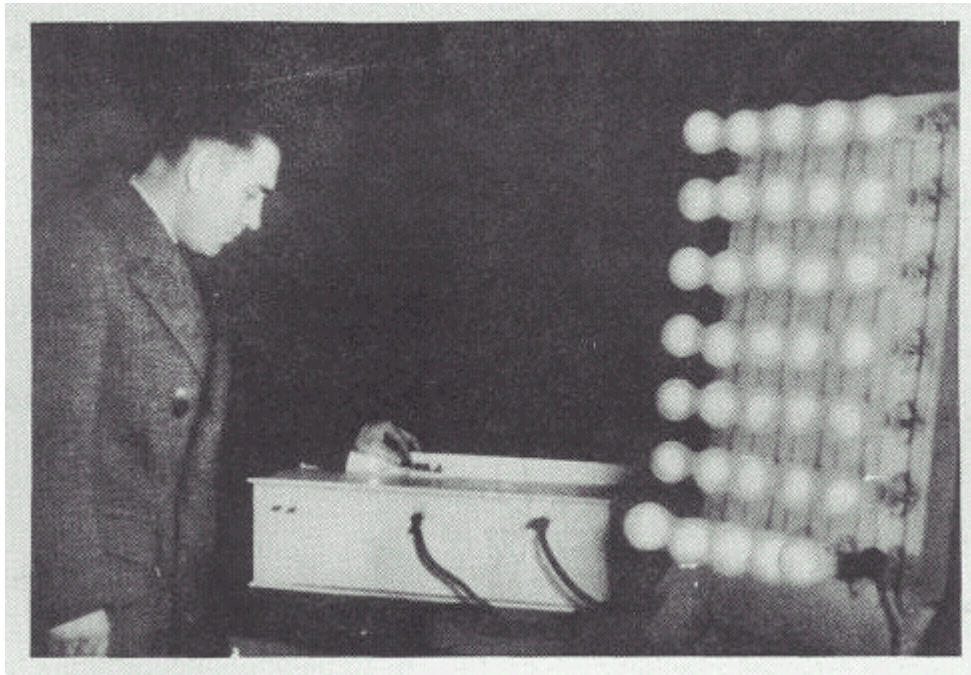

Moray's device could produce output powers up to fifty kilowatts and it had no moving parts, just a simple aerial and an earth. In spite of the frequent demonstrations, some people would not believe that this was not a hoax, so Moray invited them to choose a place and he would demonstrate the power available at any location they wanted.

They drove out into the countryside and picked a really isolated spot away from all power lines and the very few commercial radio stations in the area. They set up a very simple aerial estimated by one observer to be just fifty seven feet long and only seven or eight feet off the ground at its lowest point:

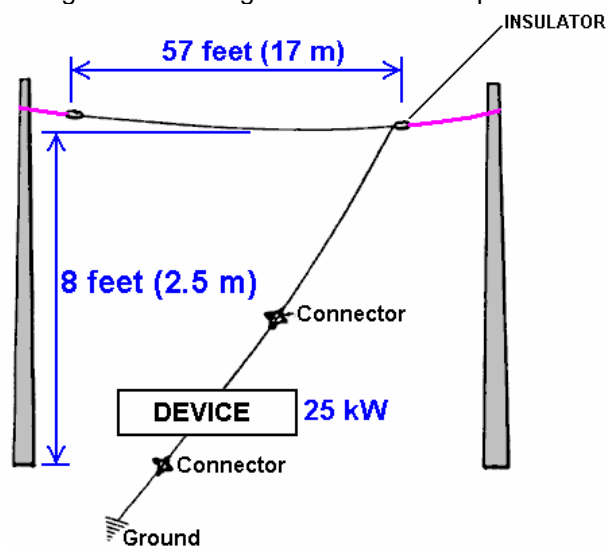

The earth connection was an eight-foot length of gas pipe which was hammered into the ground. The bank of lights being powered by Moray's device, grew brighter as the gas pipe was driven further and further into the ground, providing a better and better earth connection. Moray then demonstrated that when the aerial was disconnected, the lights went out. When the aerial was connected again, the lights were lit again. He then disconnected the earth wire and the lights went out and stayed out until the earth wire was connected again. The sceptics were completely convinced by the demonstration.

Moray's is one of several excellent and very successful devices which I can't tell you exactly how to replicate but the important point here is that a 57-foot aerial raised just 8-feet from the ground can provide kilowatts of electrical power at any location, if you know how to do it.

Moray's demonstrations were highly unpopular with some people and he was shot at in his car. He put bullet-proof glass in his car, so they came into his laboratory and shot at him there. They succeeded in intimidating him into stopping his demonstrations or publishing the exact details of how to replicate his aerial power system.

Lawrence Rayburn has recently developed an aerial system with one part raised thirty feet above the ground. He powers his farm with it and has measured more than 10 kilowatts being drawn from it.

Hermann Plauson has a patent which reads more like a tutorial on how to extract useful power from an aerial. He describes installations of his which produce 100 kilowatts of excess power as being "small" systems.

Frank Prentice has a patent on an aerial system where he drives a wire loop alongside a long length of wire mounted just seven or eight inches (200 mm) above the ground. His input power is 500 watts and the power drawn from the system is 3,000 watts, giving an excess of 2.5 kilowatts:

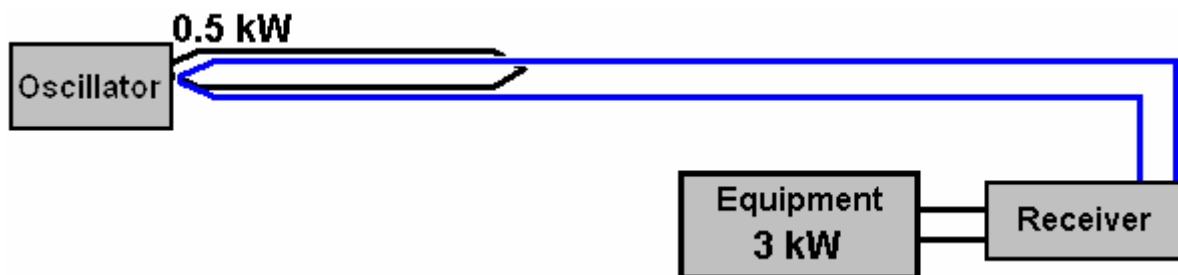

Nikola Tesla, probably the most famous person in the free-energy field, has a patent on an aerial system which uses a shiny metal plate with insulated faces as the main component of his aerial. As is common in this field, a high-quality capacitor is used to store the energy initially and then that power is pulsed through a step-down transformer which lowers the voltage and raises the current available, as shown here:

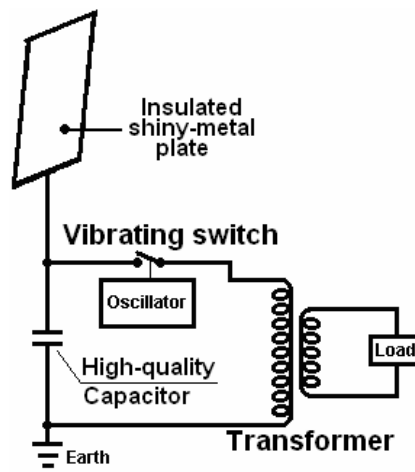

Tesla Coils. Instead of using an aerial, it is possible to use a Tesla Coil which produces very high currents **if** the primary winding is placed in the middle of the secondary winding and not at one end which is the usual configuration. Tesla directs the output on to a single metal plate and powers a load between the plate and the earth.

Don Smith demonstrates this in a video currently on YouTube. He uses a capacitor made from two metal plates with a sheet of plastic between them, instead of Tesla's insulated single plate. The load is powered between the capacitor and earth. The video shows Don using a 28-watt hand-held Tesla Coil and producing what looks like several kilowatts of power in the earth line.

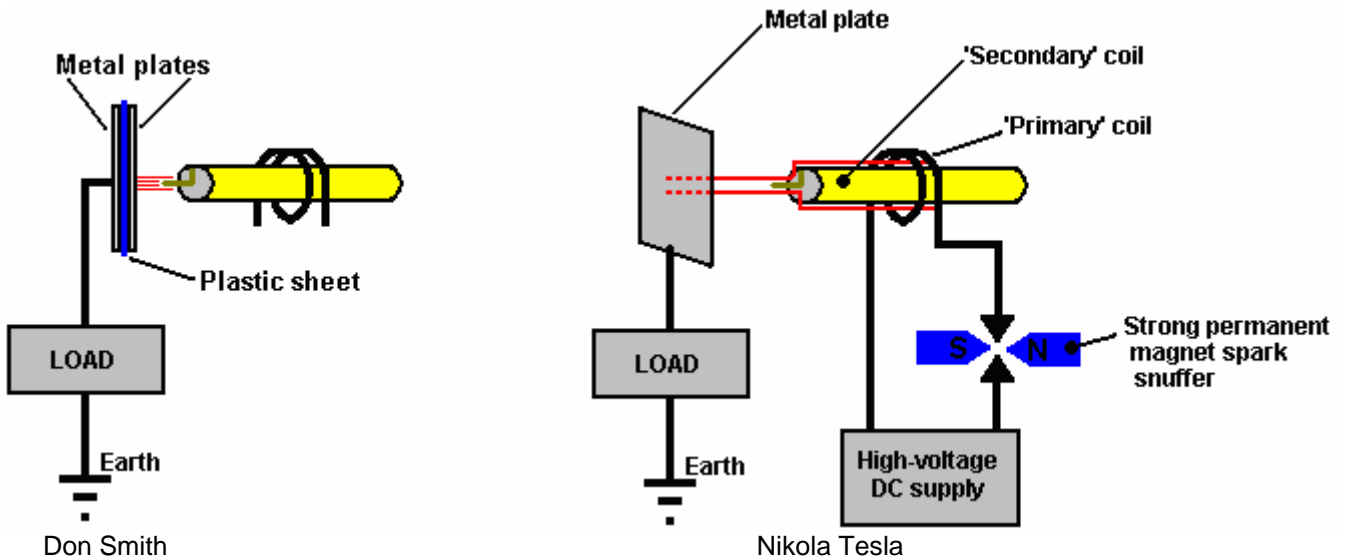

Don points out that the output power is proportional to the **square** of the voltage and the **square** of the frequency: So if you double the frequency and double the voltage there will be 16 times as much output power.

Tariel Kapanadze demonstrates this in a web video of his interview for Turkish TV. It shows him making an earth connection by burying an old car radiator, and then lighting a row of light bulbs from a Tesla Coil style fuel-less device. While the commentary is not in English, the video is very informative. You will notice that this is a substantial power output coming from a device built with a very basic style of construction where bare wires are twisted together to form an electrical connection.

When the starting battery is removed, the equipment is held in the air to show that it is self-contained and self-powered. This is another confirmation that free-energy is all around us and ready to be taken by anyone who knows how. Tariel is seen here lighting a row of five light bulbs hanging from a broom handle placed across the backs of two chairs - not exactly a high-tech, high-cost form of construction this!



This is a picture of his circuit housing, spark gap and output transformer:

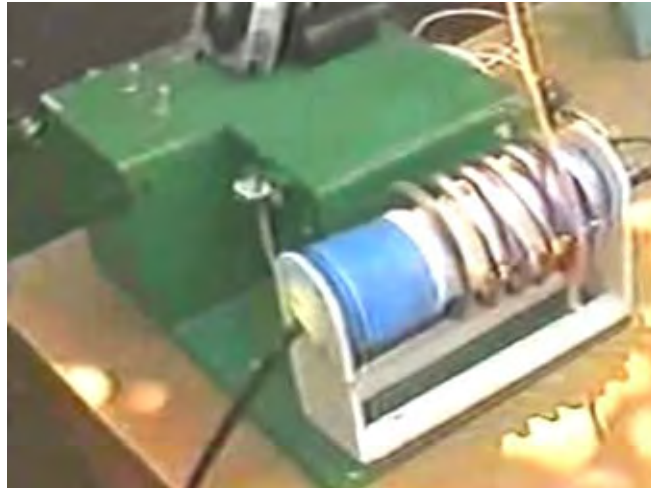

The **Colman / Seddon-Gillespie** 70-year battery. A quite different approach to getting fuel-less power was taken by Colman and Seddon-Gillespie who developed a tiny tube of harmless chemicals - copper, zinc and cadmium:

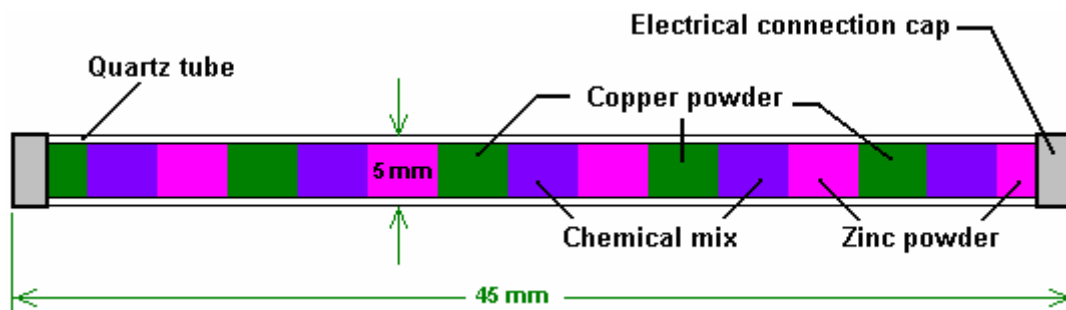

They found that if his tube was subjected to a few seconds of high-frequency electromagnetic radiation, then it became radioactive for about one hour. During that time, a kilowatt of electrical power could be drawn from this tiny tube. Near the end of the hour, another burst of electromagnetic waves keeps the tube radioactive and maintains the output current. Lead shielding is used to make this a safe device. They have a patent on this device. The expected working life of one of these tubes is estimated as being seventy years.

Electrolysis. Michael Faraday did a really excellent job of investigating how much energy was required to change water from its liquid state into a mixture of hydrogen gas and oxygen gas. Conventional science has latched on to this information and refuses to believe that it is not the last possible word on electrolysis.

This is akin to saying that the fastest a man can propel himself over the ground is by running, and refusing to accept the fact that there might be a later invention of a bicycle which would allow a much faster human-powered speed over the ground.

This is maintained in spite of the fact that a patent has been awarded to **Shigeta Hasebe** for a different style of electrolysis, using magnets and spiral electrodes like this:

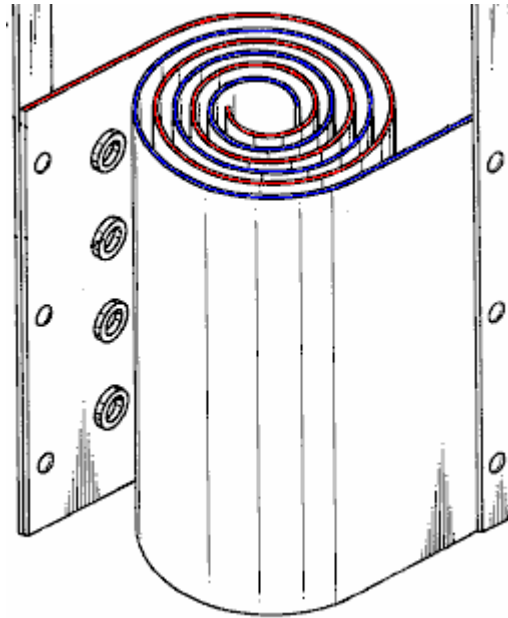

In his patent, Shigeta indicates his disappointment that his laboratory tests only showed an efficiency of ten times that of Faraday while his calculations showed that he could be getting twenty times the Faraday result. The different method, along with the use of powerful magnets at the top and bottom of his electrode pairs, bypassed the limits which Faraday had established by changing the working environment.

Bob Boyce of the USA has produced a pulsed electrolysis system which has given measured outputs which are twelve times that of Faraday's established "maximum" efficiency. This makes a nonsense of calculations based on Faraday's results. Excellent as Faraday's results are, they are no longer the limiting factor in splitting water as technology has progress beyond the methods used by Faraday.

Stanley Meyer of the USA discovered a method of splitting water into it's gas form, using very little power. Stan's work has been replicated by Dave Lawton and many other people. For example, Dr Scott Cramton has produced the "hydroxy" gas mix produced by the electrolysis of water, at a rate of 6 litres per minute with a power input of just 36 watts (12 volts at 3 amps). This is dramatically better than Faraday thought was possible and it allows power production through recombining the hydroxy gas to give water again, as the power produced is well above the amount of power needed to split the water in the first place.

John Bedini of the USA has patented a system for the rapid charging of batteries with a pulsed waveform. Using banks of batteries tends to be very expensive, very space-consuming and replacement batteries are needed at frequent intervals, giving the user a disposal problem and additional cost. Batteries have the serious restriction that they get damaged and their life shortened if the rate of discharge is less than 20 hours. So a 100 Amp-Hour battery can only manage a 5 amp current (60 watts) if it is not to be damaged.

John Bedini's spike-generating system can charge several batteries at the same time. The snag is that you can't use the batteries to power equipment while they are being charged, so you need two sets of batteries. The system is easy to make and use, but it is quite difficult to get more genuine power out of the device than is needed to drive it. The best performance that I have come across is where there is eleven times more power output than the power input.

There are several variations on John's pulser. The most common is a bicycle wheel with ferrite permanent magnets attached to the rim:

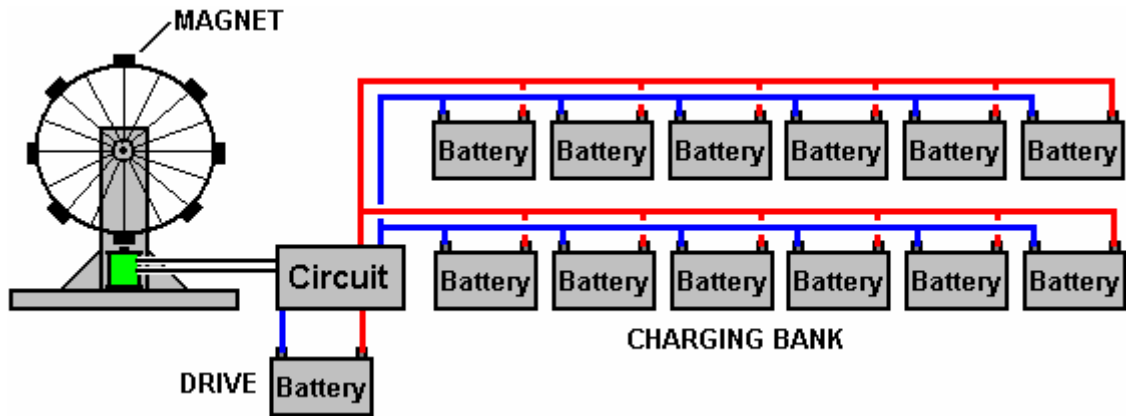

As the wheel spins, the approaching magnet generates a voltage in one winding of an electromagnet. This triggers a circuit which powers a second winding of the electromagnet. This pulse pushes the magnet away, keeping the wheel spinning. When the power to the coil is cut off, the resulting "Back EMF" voltage spike is fed to the batteries being charged. If the spike is sharp enough, it can cause an inflow of additional energy from the local environment. Interestingly, the rate at which the wheel rotates is directly proportional to the amount of charge in the batteries being charged. Here is a picture of **Ron Pugh's** high-quality construction of a Bedini pulse charger:

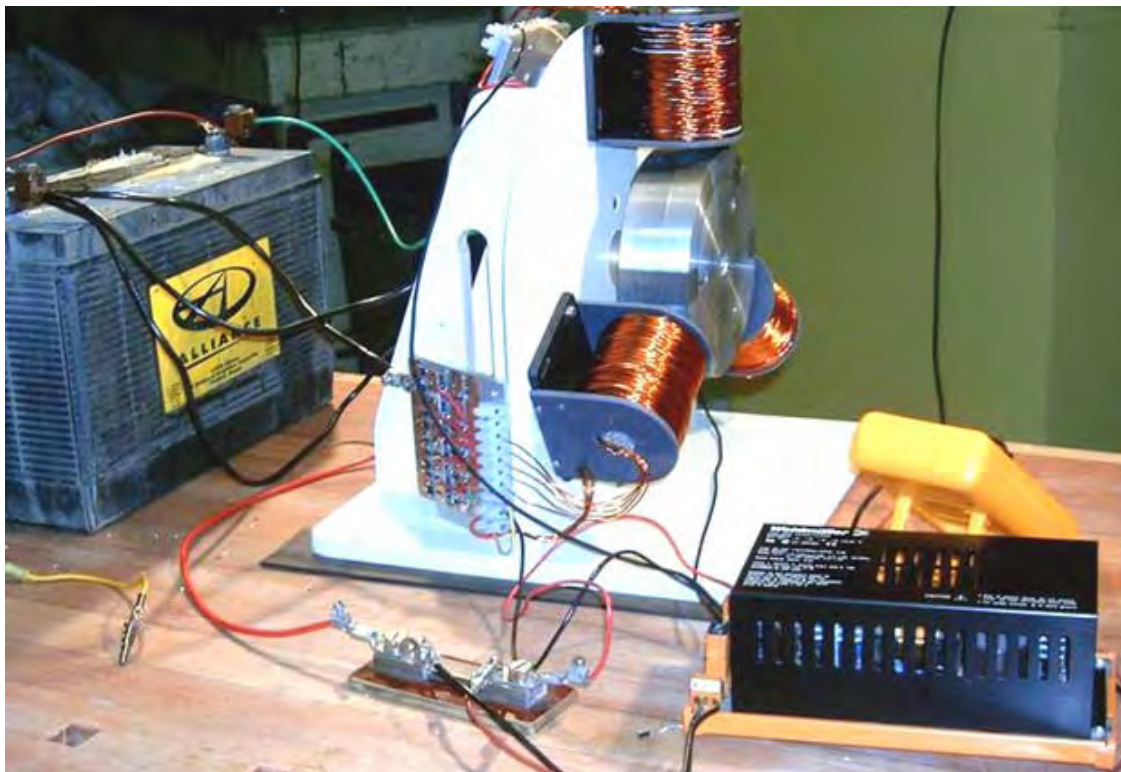

Conclusion:

The term "Free-Energy" generally means a method of drawing power from the local environment, without the need to burn a fuel. There are many different successful methods for doing this and these methods span many countries and many years.

The amount of power which can be collected can be very high and the few kilowatts needed to power a household is most definitely within the reach of most of the devices mentioned.

However, the key to drawing large amounts of electrical power from the local environment, or as Moray puts it "the sea of energy in which the Earth floats", is an ordinary, everyday commercial device, used to power the neon tubes used in advertising displays:



Not particularly expensive, nor difficult to buy, this device produces an AC waveform of thousands of volts at tens of thousands of cycles per second. Connected in the right way, it draws large amounts of power from the environment as described by Don Smith who is a very talented American man. A specially shaped step-up transformer called a Tesla Coil is used to boost the voltage even higher and that has a dramatic effect because the power drawn into the circuit from outside is proportional to the square of the voltage and the square of the frequency. So, if you double the voltage and double the frequency, the extra power is boosted by a factor of sixteen times.

The technique used looks mad if you don't understand what is happening, because you step up the voltage and frequency, and then you step them both down again, which looks like a waste of time, but, and it is a big "but", one simple device described in chapter 3 produces excess power of 160 kilowatts as well as powering itself.

In this brief introduction, not much detail has been given about the devices mentioned and only a small selection of devices have been covered. Much more detail is available in this and the other chapters of this eBook

The 'bottom line' is that energy can definitely be drawn from the local environment in sufficient quantities to supply all of our needs. For whatever reason, conventional science appears determined not to accept this basic fact and denies it at every opportunity. It seems likely that vested financial interests are the root cause of this refusal to accept the facts. The true scientific method is to upgrade scientific theory in the light of observed fact and new discoveries, but the true scientific method is not being followed at the present time.

Therefore, I invite you to examine the facts, read the information in this eBook and the additional information on the website <http://www.free-energy-info.tuks.nl/> and make up your own mind on the subject. Please note that this is not a fixed body of information and this eBook normally gets a significant upgrade on average once per week. Consequently, I suggest that you download a new copy say, once per month in order to stay up to date with what is happening.

Patrick Kelly

<http://www.free-energy-info.tuks.nl/>

Chapter 1: Magnet Power

One thing which we are told, is that permanent magnets can't do any work. Oh yes, magnets can support themselves against the pull of gravity when they stick on your refrigerator, but, we are told, they can't do any work. Really?

What exactly is a permanent magnet? Well, if you take a piece of suitable material like 'soft' iron, put it inside a coil of wire and drive a strong electrical current through the coil, then that converts the iron into a permanent magnet. What length of time does the current need to be in the coil to make the magnet? Less than one hundredth of a second. How long can the resulting magnet support its own weight against gravity? Years and years. Does that not strike you as strange? See how long you can support your own body weight against gravity before you get tired. Years and years? No. Months, then? No. Days, even? No.

Well if you can't do it, how come the magnet can? Are you suggesting that a single pulse for a minute fraction of a second can pump enough energy into the piece of iron to power it for years? That doesn't seem very logical, does it? So, how does the magnet do it?

The answer is that the magnet does not actually exert any power at all. In the same way that a solar panel does not put any effort into producing electricity, the power of a magnet flows from the environment and not from the magnet. The electrical pulse which creates the magnet, aligns the atoms inside the iron and creates a magnetic "dipole" which has the same effect that the electrical "dipole" of a battery does. It polarises the quantum environment surrounding it and causes great streams of energy flow around itself. One of the attributes of this energy flow is what we call "magnetism" and that allows the magnet to stick to the door of your refrigerator and defy gravity for years on end.

Unlike the battery, we do not put it in a position where it immediately destroys its own dipole, so as a result, energy flows around the magnet, pretty much indefinitely. We are told that permanent magnets can't be used to do useful work. That is not true.



ShenHe Wang's Permanent Magnet Motor.

This is a picture of a Chinese man, ShenHe Wang, who has designed and built an electrical generator of five kilowatt capacity. This generator is powered by permanent magnets and so uses no fuel to run. It uses magnetic particles suspended in a liquid. It should have been on public display at the Shanghai World Expo from 1st May 2010 to 31st October 2010 but the Chinese government stepped in and would not allow it. Instead, they would only allow him show a wristwatch-size version which demonstrated that the design worked but which would be of no practical use in power generation:



Most inventors don't seem to realise it, but almost every government is opposed to members of the public getting hold of any serious free-energy device (although they are happy to use these devices themselves). Their objective is to dominate and control ordinary people and a major factor in that is to control the supply and cost of power. A second method used everywhere is to control money, and without noticing it, governments manage to take away about 78% of people's income, mainly by concealed methods, indirect taxes, charges, fees, ... If you want to know more about it, then visit www.yourstrawman.com but please understand that the reason why free-energy devices are not for sale in your local shop has to do with political control and vested financial interests and has nothing whatsoever to do with the technology. All technological problems have been solved, literally thousands of times, but the benefits have been suppressed by those in power.

Two of Mr Wang's 5 kilowatt generators successfully completed the Chinese government's mandatory six-month "Reliability and Safety" testing programme in April 2008. One large Chinese consortium has started buying up coal-fired electricity generating stations in China in order to refurbish them with pollution-free large versions of Wang's generator. Some information on the construction of the Wang motor is available here: <http://www.free-energy-info.tuks.nl/Wang.pdf>.



The motor consists of a rotor which has four arms and which sits in a shallow bowl of liquid which has a colloidal suspension of magnetic particles in it:

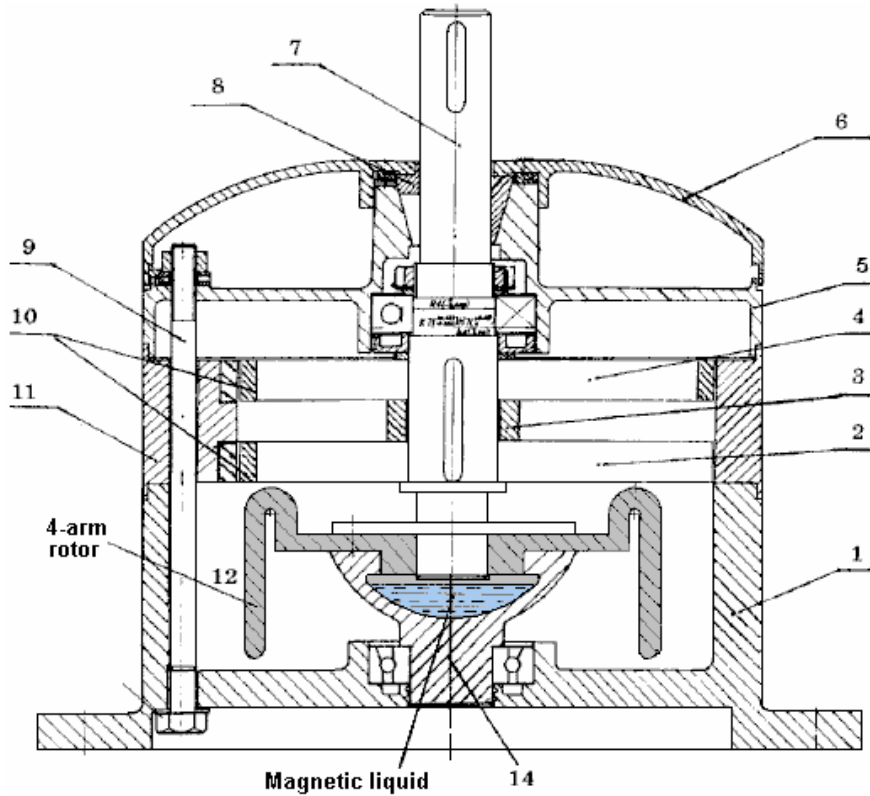

There is a patent on the motor but it is not in English and what it reveals is not a major amount.

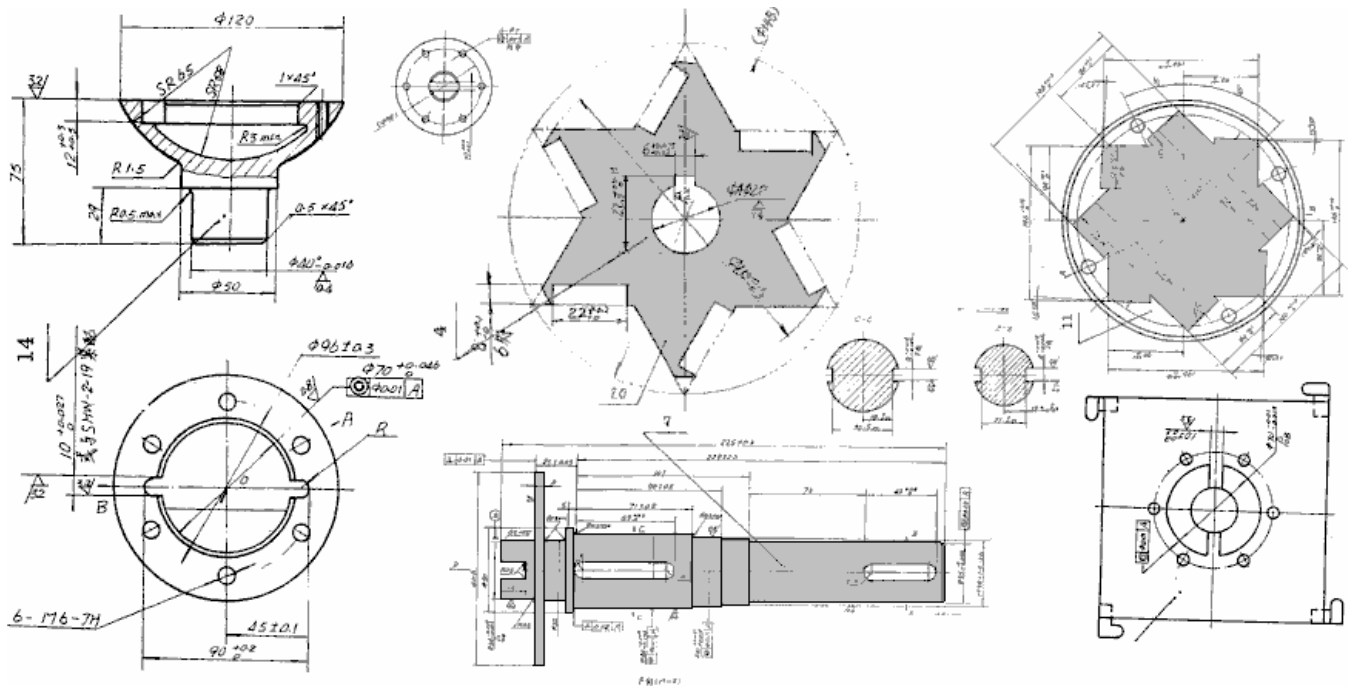

It was Mr Wang's intention to give his motor design to every country in the world and invite them to make it for themselves. This very generous attitude does not take into account the many vested financial interests in each country, not the least of which is the government of that country, which will oppose the introduction of any device which taps into free-energy and which, consequently, would destroy their continuous streams of income. It is even possible that you would not be allowed to go to China, buy one and bring it back with you for use at home.

It is not easy to arrange permanent magnets in a pattern which can provide a continuous force in a single direction, as there tends to be a point where the forces of attraction and repulsion balance and produce a position in which the rotor settles down and sticks. There are various ways to avoid this happening. It is possible to modify the magnetic field by diverting it through a soft iron component.

There are many other designs of permanent magnet motor, but before showing some of them, it is probably worth discussing what useful work can be performed by the rotating shaft of a permanent magnet motor. With a home-built permanent magnet motor, where cheap components have been used and the quality of workmanship may not be all that great (though that is most definitely not the case with some home construction), the shaft power may not be very high. Generating electrical power is a common goal, and that can be achieved by causing permanent magnets to pass by coils of wire. The closer to the wire coils, the greater the power generated in those coils. Unfortunately, doing this creates magnetic drag and that drag increases with the amount of electrical current being drawn from the coils.

There are ways to reduce this drag on the shaft rotation. One way is to use an Ecklin-Brown style of electrical generator, where the shaft rotation does not move magnets past coils, but instead, moves a magnetic screen which alternatively blocks and restores a magnetic path through the generating coils. A commercially available material called "mu-metal" is particularly good as magnetic shield material and a piece shaped like a plus sign is used in the Ecklin-Brown generator.

John Ecklin's Magnetic-Shielding Generator.

John W. Ecklin was granted US Patent Number 3,879,622 on 29th March 1974. The patent is for a magnet/electric motor generator which produces an output greater than the input necessary to run it. There are two styles of operation. The main illustration for the first is:

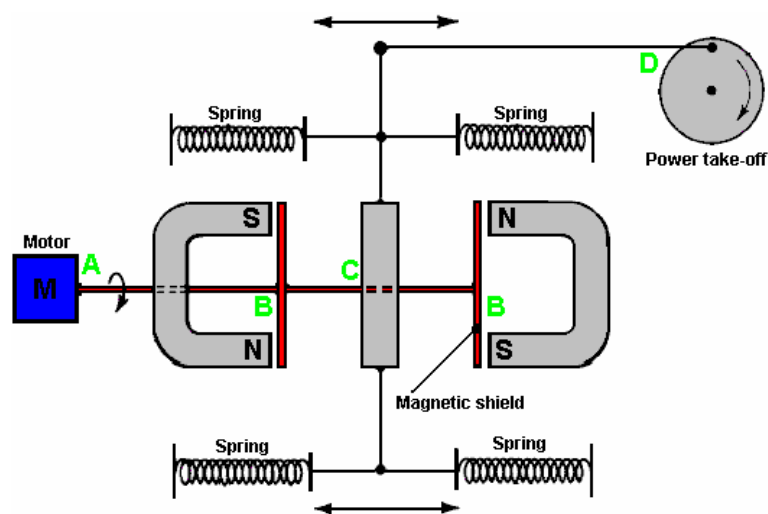

Here, the (clever) idea is to use a small low-power motor to rotate a magnetic shield to mask the pull of two magnets. This causes a fluctuating magnet field which is used to rotate a generator drive.

In the diagram above, the motor at point 'A' rotates the shaft and shielding strips at point 'B'. These rectangular mu-metal strips form a very conductive path for the magnetic lines of force when they are lined up with the ends of the magnets and they effectively shut off the magnet pull in the area of point 'C'. At point 'C', the spring-loaded traveller is pulled to the left when the right-hand magnet is shielded and the left hand magnet is not shielded. When the motor shaft rotates further, the traveller is pulled to the right when the left-hand magnet is shielded and the right hand magnet is not shielded. This oscillation is passed by mechanical linkage to point 'D' where it is used to rotate a shaft used to power a generator.

As the effort needed to rotate the magnetic shield is relatively low, it is claimed that the output exceeds the input and so can be used to power the motor which rotates the magnetic shield.

The second method for exploiting the idea is shown in the patent as:

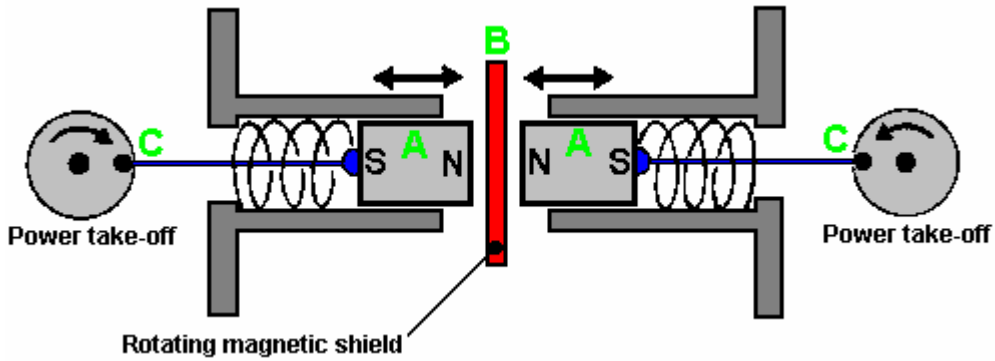

Here, the same shielding idea is utilised to produce a reciprocating movement which is then converted to two rotary motions to drive two generators. The pair of magnets 'A' are placed in a housing and pressed towards each other by two springs. When the springs are fully extended, they are just clear of the magnetic shield 'B'. When a small electric motor (not shown in the diagram) moves the magnetic shield out of the way, the two magnets are strongly repelled from each other as their North poles are close together. This compresses the springs and through the linkages at 'C' they turn two shafts to generate output power.

A modification of this idea is the **Ecklin-Brown Generator**. In this arrangement, the movable magnetic shielding arrangement provides a direct electrical output rather than a mechanical movement:

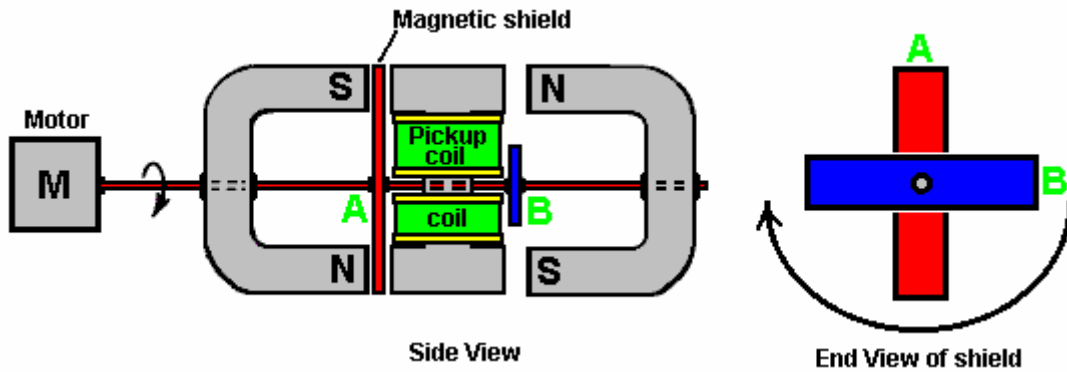

Here, the same motor and rotating magnetic shield arrangement is used, but the magnetic lines of force are blocked from flowing through a central I-piece. This I-piece is made of laminated iron slivers and has a pickup coil or coils wound around it.

The device operates as follows:

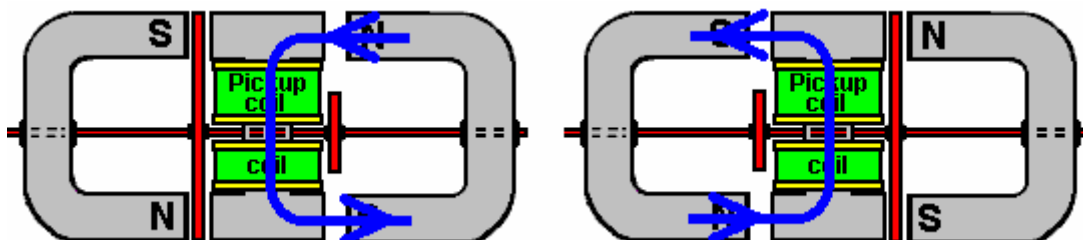

In the position shown on the left, the magnetic lines of force flow **downwards** through the pickup coils. When the motor shaft has rotated a further ninety degrees, the situation on the right occurs and there, the magnetic lines of force flow **upwards** through the pickup coils. This is shown by the blue arrows in the diagram. This reversal of magnetic flux takes place four times for every rotation of the motor shaft.

While the Ecklin-Brown design assumes that an electric motor is used to rotate the mu-metal shield, there does not seem to be any reason why the rotation should not be done with a permanent magnet motor.

Another effective power take-off system is that used by the “Phi Transformer” (“Phi” is pronounced “Fi”). In this design, the magnetic drag is reduced by containing the magnetic flux in a laminated iron ring or “toroid”. Again, the design expects an electric motor to be used to spin the rotor, but there does not seem to be any great reason why a permanent magnet motor should not be used instead.

Toroidal shapes are clearly important in many devices which pull in additional energy from the environment, even to the extent that Bob Boyce warns against the high-frequency sequential pulsing of coils wound on a toroid yoke, producing a rotating magnetic field as unpredictable surge events can generate some 10,000 amps of additional current which will burn out the circuit components and can very well trigger a radiant energy build up which can create a lightning strike. Bob himself has been hit by just such a lightning strike and he is lucky to have survived. Lesser systems such as the toroid transformer used in Bob’s electrolyser system are safe even though they generate a power gain. So the many toroidal system designs are definitely worth examining.

Howard Johnson’s Permanent Magnet Motor.

Returning to permanent magnet motors themselves, one of the top names in this field is Howard Johnson. Howard built, demonstrated and gained US patent 4,151,431 on 24th April 1979, from a highly sceptical patent office for, his design of a permanent magnet motor. He used powerful but very expensive Cobalt/Samarium magnets to increase the power output and demonstrated the motor principles for the Spring 1980 edition of *Science and Mechanics* magazine. His motor configuration is shown here:

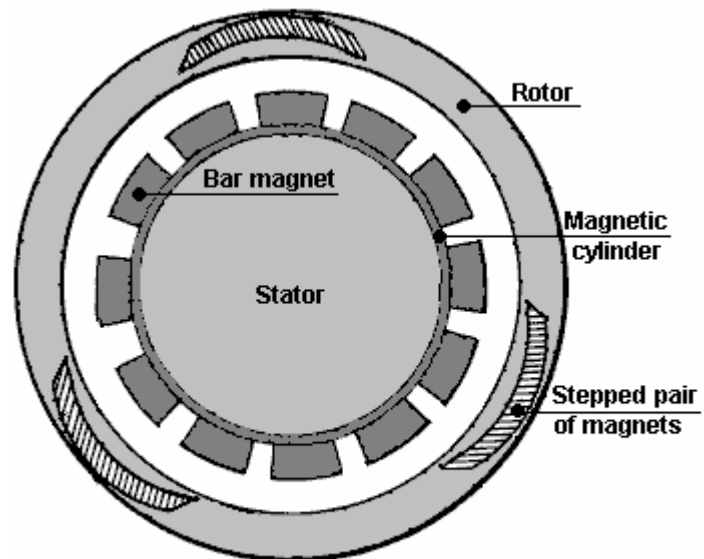

Note that the gaps between the magnets are not a constant width.

The point that he makes is that the magnetic flux of his motor is always unbalanced, thus producing a continuous rotational drive. The rotor magnets are joined in stepped pairs, connected by a non-magnetic yoke. The stator magnets are placed on a mu-metal apron cylinder. Mu-metal is very highly conductive to magnetic flux (and is expensive). The patent states that the armature magnet is 3.125” (79.4 mm) long and the stator magnets are 1” (25.4 mm) wide, 0.25” (6 mm) deep and 4” (100 mm) long. It also states that the rotor magnet pairs are **not** set at 120 degrees apart but are staggered slightly to smooth out the magnetic forces on the rotor. It also states that the air gap between the magnets of the rotor and the stator are a compromise in that the greater the gap, the smoother the running but the lower the power. So, a gap is chosen to give the greatest power at an acceptable level of vibration.

Howard considers permanent magnets to be room-temperature superconductors. Presumably, he sees magnetic material as having electron spin directions in random directions so that their net magnetic field is near zero until the electron spins are aligned by the magnetising process which then creates an overall net permanent magnetic field, maintained by the superconductive electrical flow.

The magnet arrangement is shown here, with the inter-magnet gaps assessed from the drawing in Howard’s patent:

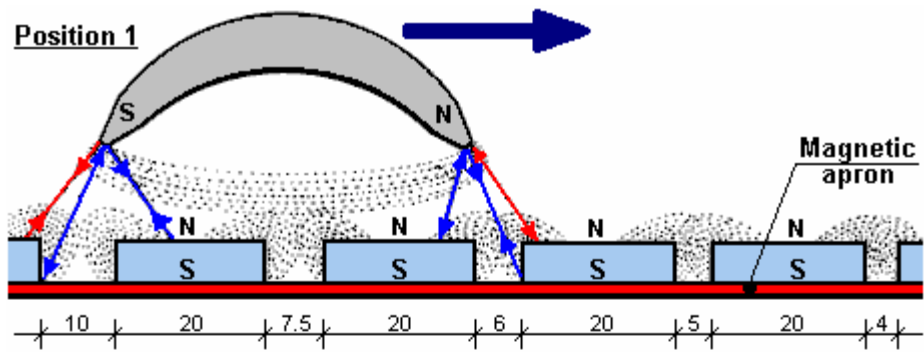

Note that Howard Johnson did not draw the inter-magnet gaps as equal distances

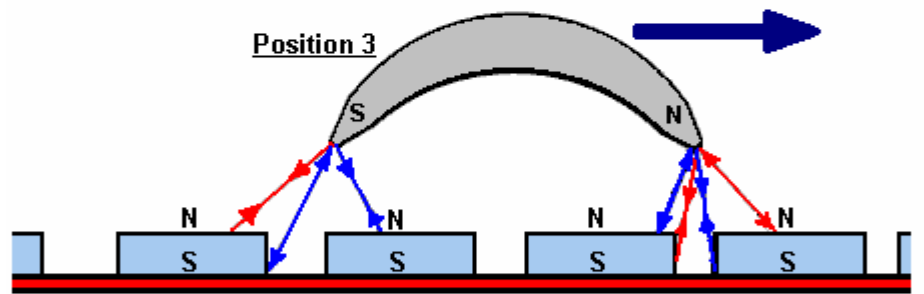
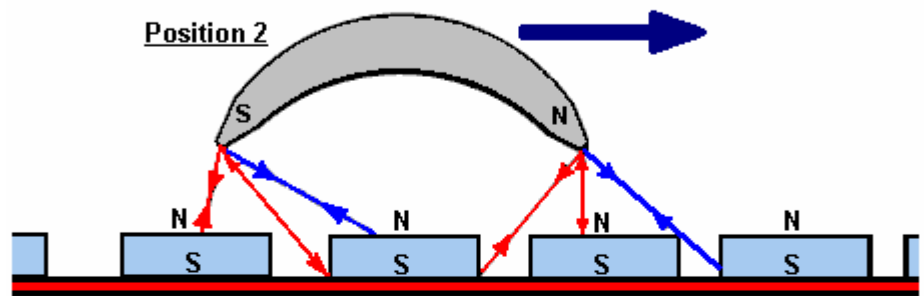

SIDE VIEWS

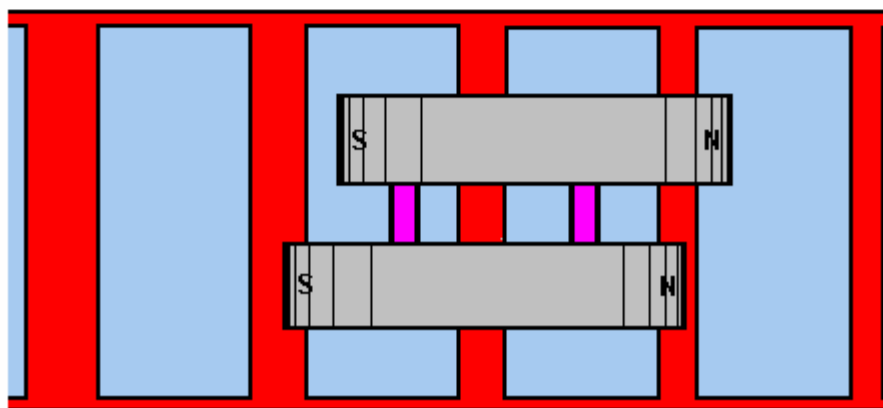

TOP VIEW

A magazine article on this can be seen at <http://newebmasters.com/freeenergy/sm-pg48.html>.

The "Carousel" Permanent Magnet Motor/Generator.

US Patent 5,625,241, included in the Appendix, presents the specific details of a simple electrical generator powered by permanent magnets alone. This generator can also be used as a motor. The construction is not particularly complicated:

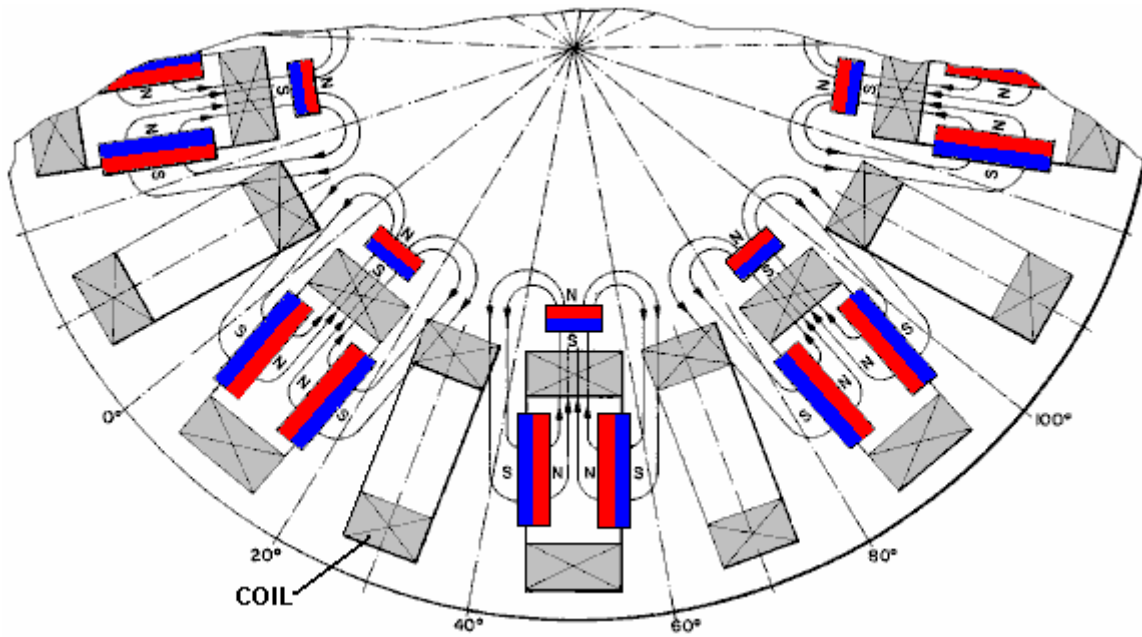

It uses an arrangement where permanent magnets are associated with every second coil set around the rotor. Operation is self-powered and the magnet arrangement is clearly defined:

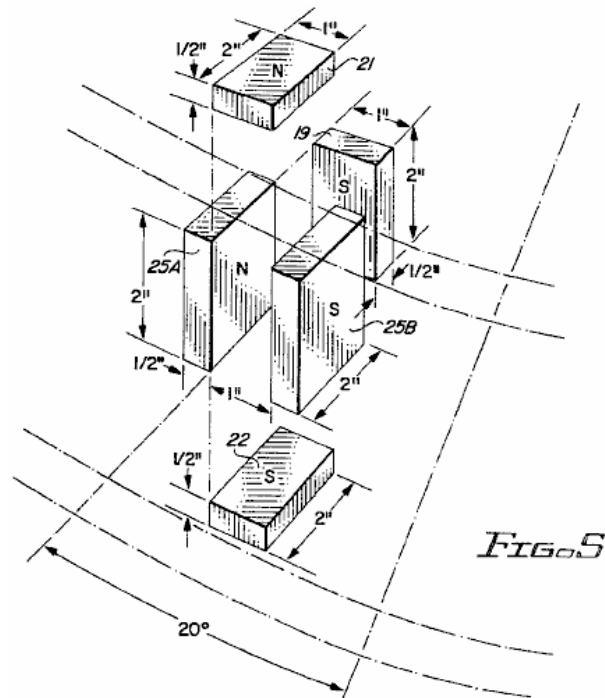

And the physical arrangement of the device is not particularly complicated:

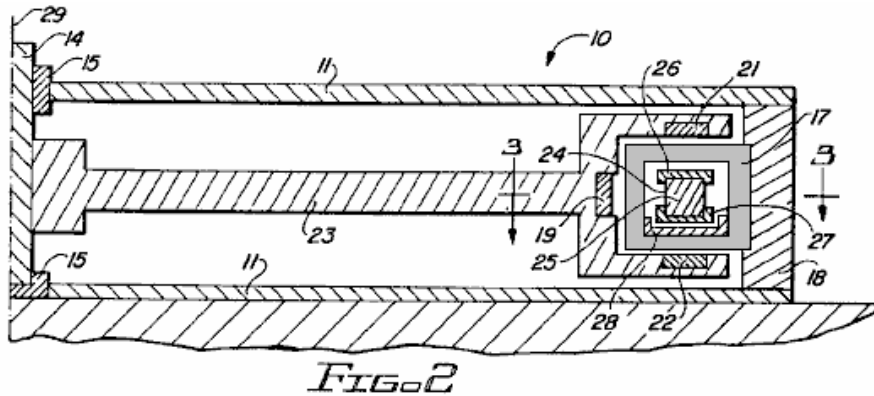

This is a patent which is definitely worth reading and considering, especially since it is not a complicated presentation on the part of the authors, Harold Ewing, Russell Chapman and David Porter. This seemingly very effective generator appears to be overlooked at the present time. It seems quite clear that permanent magnet motors are a wholly viable option for the home constructor and they are capable of substantial power outputs over long periods, however, it should be noted that motors using magnets alone are notoriously difficult to get operational and while it can be done, motors which use moving shielding or pulsed electrical shielding are much more viable for the first-time constructor – motors such as the Charles Flynn motor or the Stephen Kundel motor.

Robert Tracy's Permanent Magnet Motor.

Some people have opted for permanent magnet motors where the field is shielded at the appropriate moment by a moving component of the motor. Robert Tracy was awarded US Patent Number 3,703,653 on 21st November 1972 for a "Reciprocating Motor with Motion Conversion Means". His device uses magnetic shields placed between pairs of permanent magnets at the appropriate point in the rotation of the motor shaft:

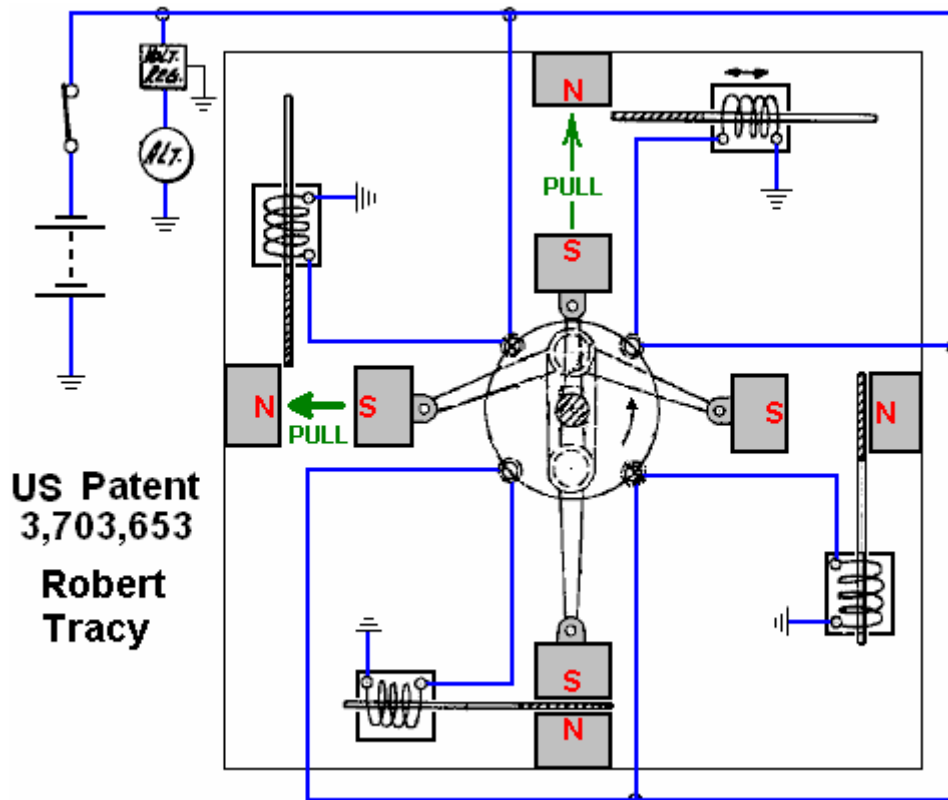

Ben Teal's Electromagnet Motor.

Motors of this kind are capable of considerable power output. The very simple motor, originally built by Ben Teal using wood as the main construction material, was awarded US Patent Number 4,093,880 in June 1978. He found that, using his hands, he could not stop the motor shaft turning in spite of it being such a very simple motor design:

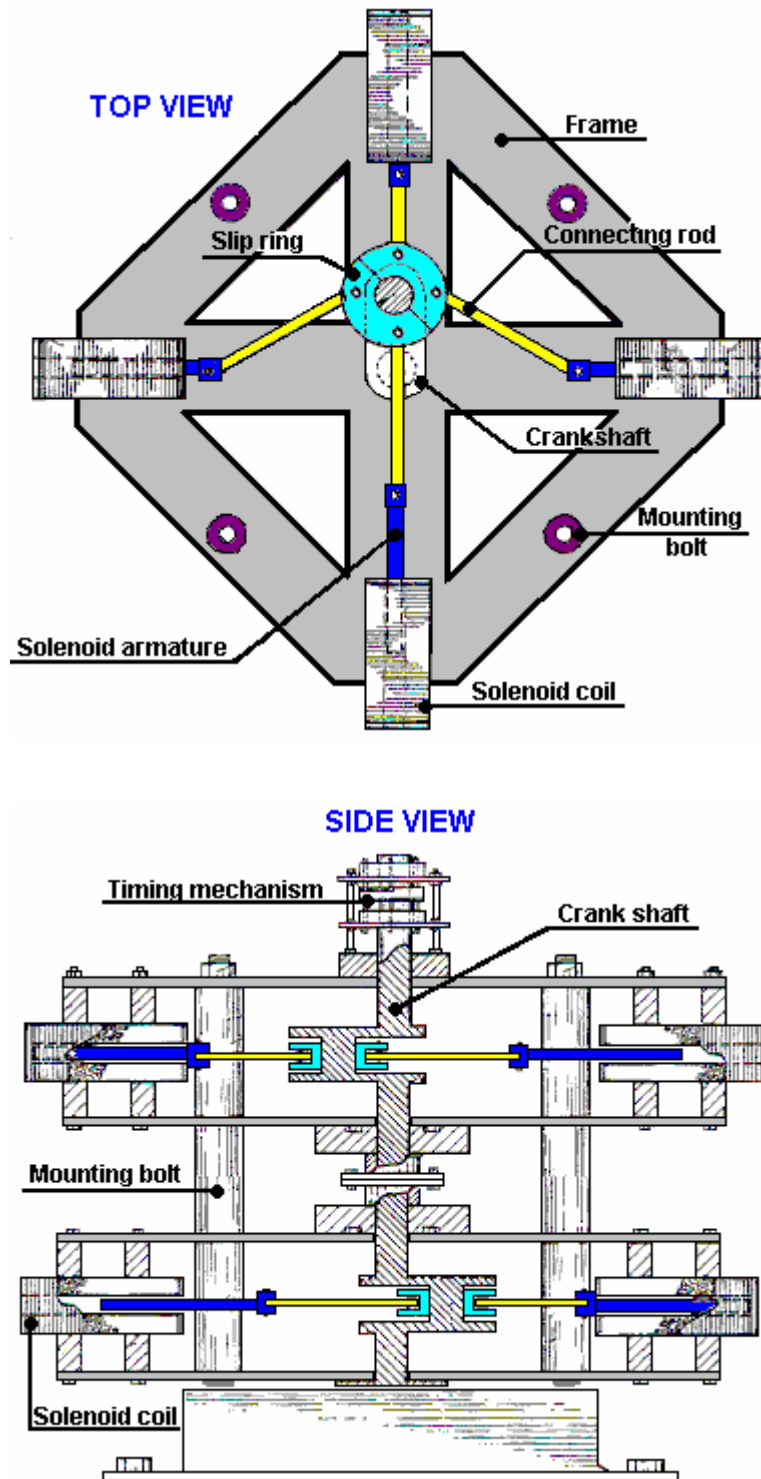

The motor operation is as simple as possible with just four switches made from springy metal, pushed by a cam on the rotor shaft. Each switch just powers it's electromagnet when it needs to pull and disconnects it when the pull is completed. The resulting motor is very powerful and very simple. Additional power can be had by just stacking one or more additional layers on top of each other. The above diagram shows two layers stacked on top of one another. Only one set of four switches and one cam is needed no matter how many layers are used, as the solenoids vertically above each other are wired together in parallel as they pull at the same time.

The power delivered by the Teal motor is an indication of the potential power of a permanent magnet motor which operates in a rather similar way by moving magnetic shields to get a reciprocating movement. Placing a resistor and capacitor across each switch contact both suppresses sparks and feeds current back to the battery when the contact opens, and this extends the battery life considerably.

The Jines Permanent Magnet Motor.

James E. Jines and James W. Jines were awarded US Patent 3,469,130 on 23rd September 1969 "Means for Shielding and Unshielding Permanent Magnets and Magnetic Motors Utilising the Same" and which is in the Appendix. This magnet motor design uses selective shielding of the drive magnets to produce a continuous force in one direction. It also has a mechanical arrangement to progressively adjust the shielding to adjust the power of the motor.

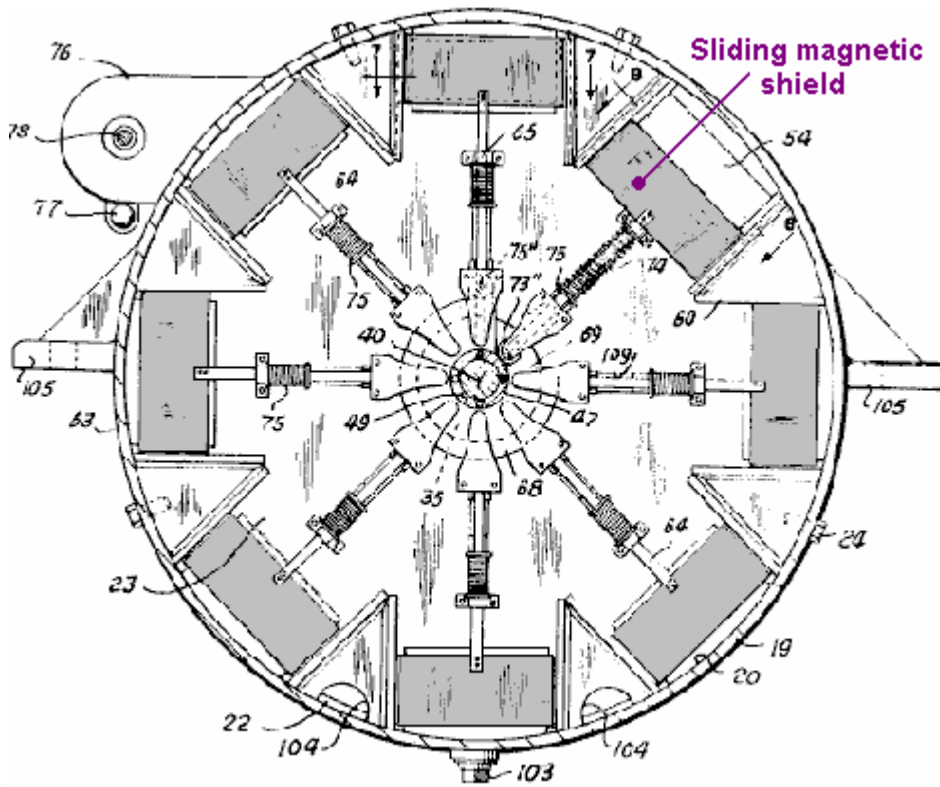

END VIEW

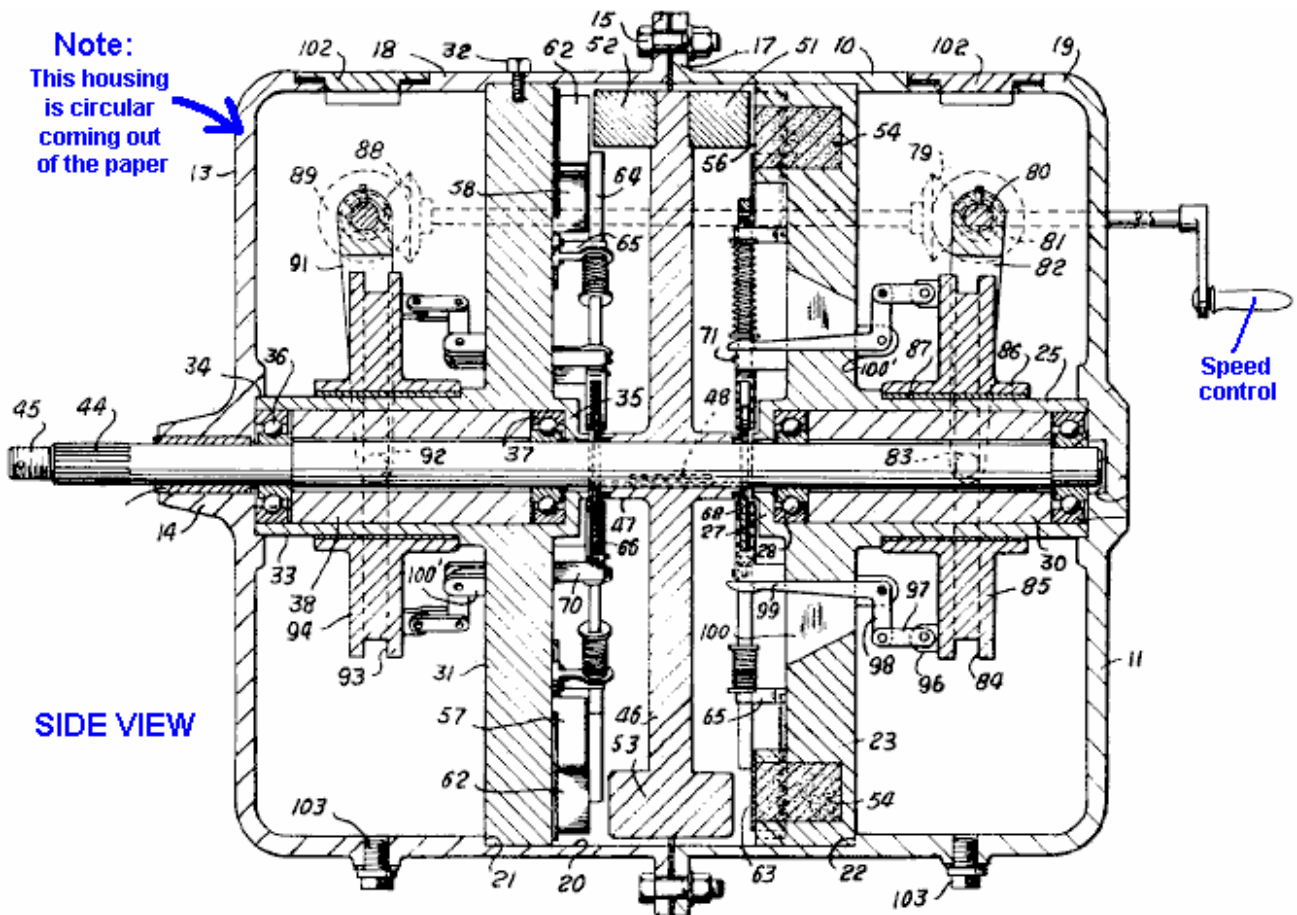

SIDE VIEW

This is a very interesting design of magnetic motor, especially since it does not call for any materials which are not readily available from many suppliers. It also has the advantage of not needing any form of exact adjustment or balancing of magnetic forces to make it operate.

Stephen Kundel's Permanent Magnet Motor.

Stephen Kundel's motor design is shown in full detail in his patent which is shown on page A - 968 of the Appendix. It uses a simple oscillating motion to position the "stator" magnets so that they provide a continuous rotational force on the output shaft:

Figure 1A

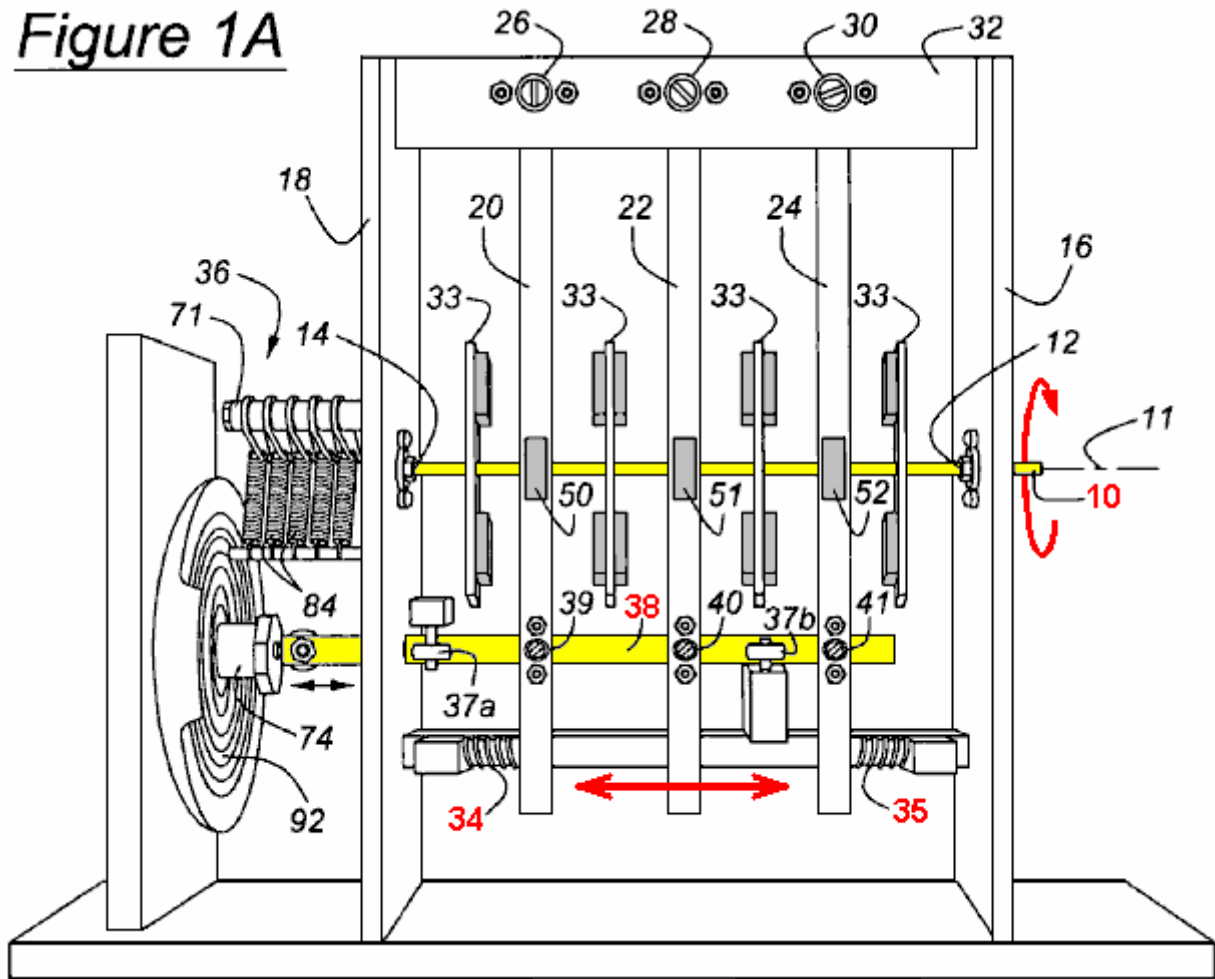

Here, the yellow arm marked **38**, rocks to the right and left, pushed by a solenoid coil **74**. There is no obvious reason why this rocking motion could not be achieved by a mechanical linkage connected to the rotating output shaft **10**. The three arms **20**, **22** and **24**, being pivoted at their upper points, are pushed into a central position by the springs **34** and **35**. The magnets **50**, **51** and **52**, are moved by these arms, causing a continuous rotation of the output drive shaft **10**. The movement of these magnets avoids the position where the magnets reach a point of equilibrium and lock into a single position.

Figure 2

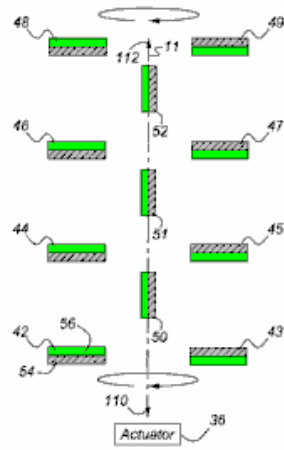
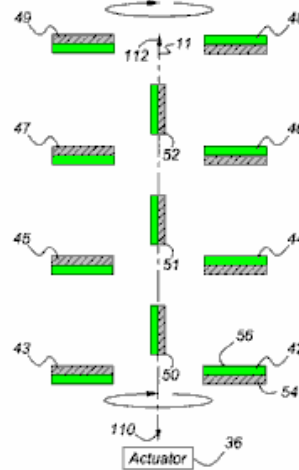

Figure 3



Figures 2 and 3 show the position of the magnets, with the Figure 3 position showing a point in the output shaft rotation which is 180 degrees (half a turn) further on than the position shown in Figure 2.

Some other, more powerful magnet arrangements which can be used with this design are shown in the full patent in the Appendix.

This design does not seem to appeal to many constructors in spite of the fact that it must be one of the easiest magnet motors to set up and make work. The output power level can be as big as you want as additional layers of magnets can be added. The operation is very simple and it can, perhaps, be seen more easily if just one lever arm is considered. The lever arm has just two working positions. In one position it acts on one set of rotor magnets and in the second position it acts on a second set of rotor magnets. So, we will look at each set in turn. If there are two magnets near each other, one fixed in position and the other free to move like this:

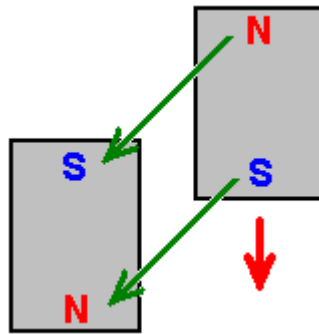

The magnets have a strong attraction to each other because of the North and South poles attracting each other. However, as the two South poles repel each other, the movement of the approaching magnet is not directly along the green arrows shown but initially is in the direction shown by the red arrow. This situation continues with the moving magnet approaching the fixed magnet and the pull between them getting stronger all the time. But, the situation changes immediately the moving magnet reaches its closest point to the fixed magnet. Momentum starts to carry it past, but at that point the direction of the pull between the magnets starts to oppose the onward movement of the moving magnet:

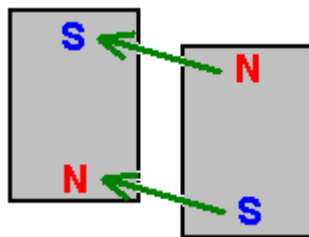

If the fixed magnet remains in that position, then the moving magnet will oscillate briefly and come to a halt directly opposite the fixed magnet like this:

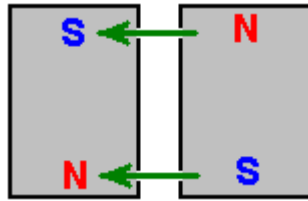

The attraction forces between the two magnets is now wholly horizontal and there is no force on the movable magnet to cause it to move. This is simple stuff, understood by anyone who has examined permanent magnets in order to see what they do. Stephen Kundel is well aware of this, and so he moves the “fixed” magnet rapidly out of the way before the reverse-direction pull slows the moving magnet down. He moves the magnet sideways and slides another one into position like this:

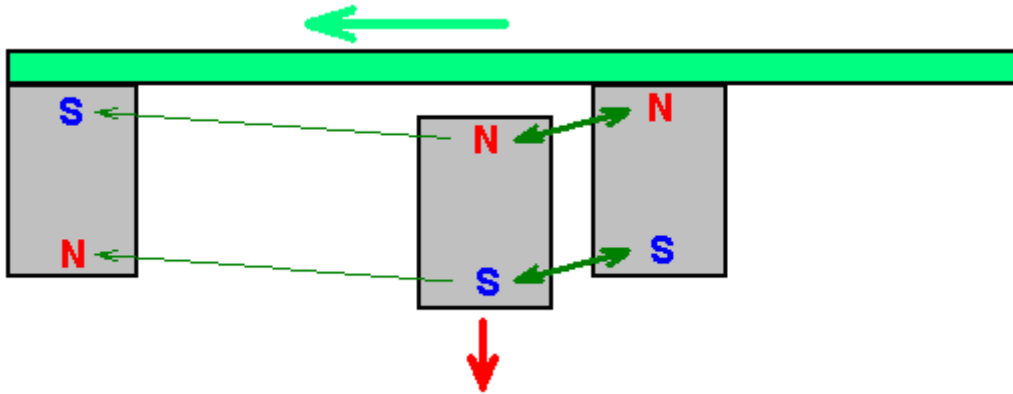

The new magnet is now much closer to the moving magnet and so has a much greater influence on it. The poles of the new magnet match the poles of the moving magnet which causes them to push apart very strongly, driving the moving magnet onwards in the direction it was moving in. The moving magnet moves very quickly and so gets out of the range of the fixed magnets quite quickly, at which point, the “fixed” magnets of the stator are moved back into their original position where they act in the same way on the next moving magnet attached to the rotor.

This very simple operation only requires a small force to move the stator magnets sideways between their two positions, while the force between the stator magnets and the rotor magnets can be high, producing considerable rotational power to the axle on which the rotor discs are attached.

The efficiency of the system is further boosted because when the stator magnets are in the first position shown, the second “fixed” magnet is not sitting idle but instead, it acts on the magnet of the next rotor disc:

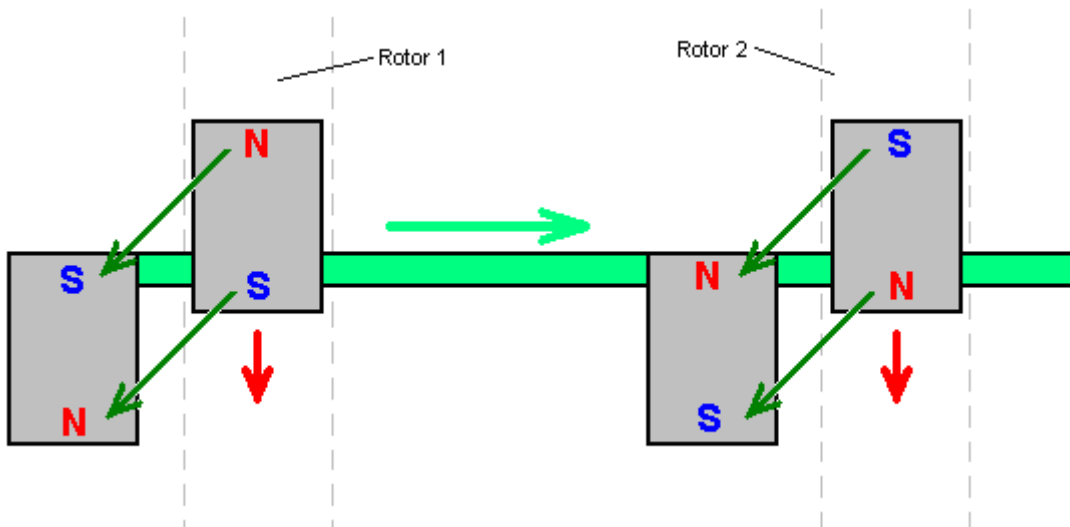

For this, the magnets attached to Rotor disc 2 have to be positioned so that their poles are the reverse of those attached to Rotor disc 1. Stephen uses a loudspeaker to wobble the horizontal bar on which the stator magnets are mounted, backwards and forwards as a loudspeaker has that mechanism already built into it. Don Kelly’s

permanent magnet motor also uses this very simple idea of moving the stator magnets out of the way at the appropriate moment.

Charles “Joe” Flynn’s Permanent Magnet Motor.

Patent US 5,455,474 dated 3rd October 1995 and shown in full in the Appendix, gives details of this interesting design. It says: “This invention relates to a method of producing useful energy with magnets as the driving force and represents an important improvement over known constructions and it is one which is simpler to construct, can be made to be self starting, is easier to adjust, and is less likely to get out of adjustment. The present construction is also relatively easy to control, is relatively stable and produces an amazing amount of output energy considering the source of driving energy that is used. The present construction makes use of permanent magnets as the source of driving energy but shows a novel means of controlling the magnetic interaction or coupling between the magnet members and in a manner which is relatively rugged, produces a substantial amount of output energy and torque, and in a device capable of being used to generate substantial amounts of energy.”

The patent describes more than one motor. The first one is like this when seen from the side:

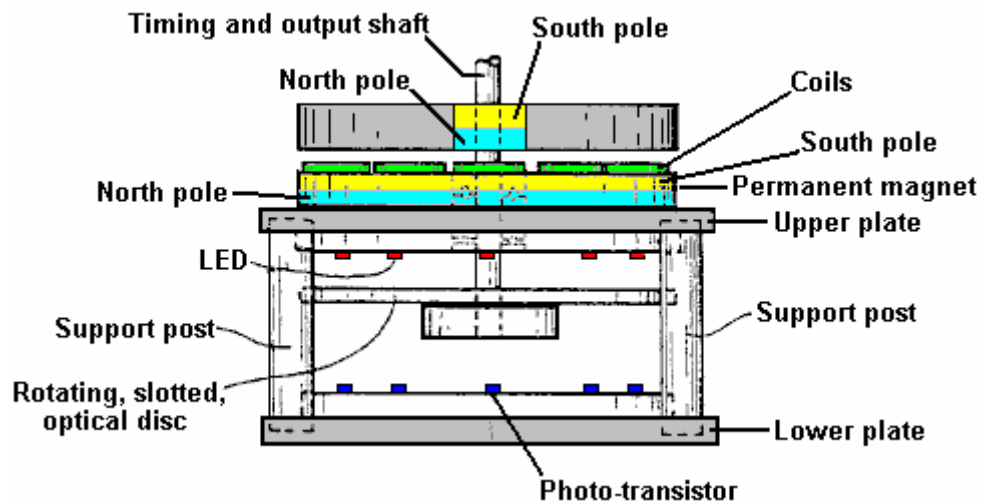

An exploded view, shows the different parts clearly:

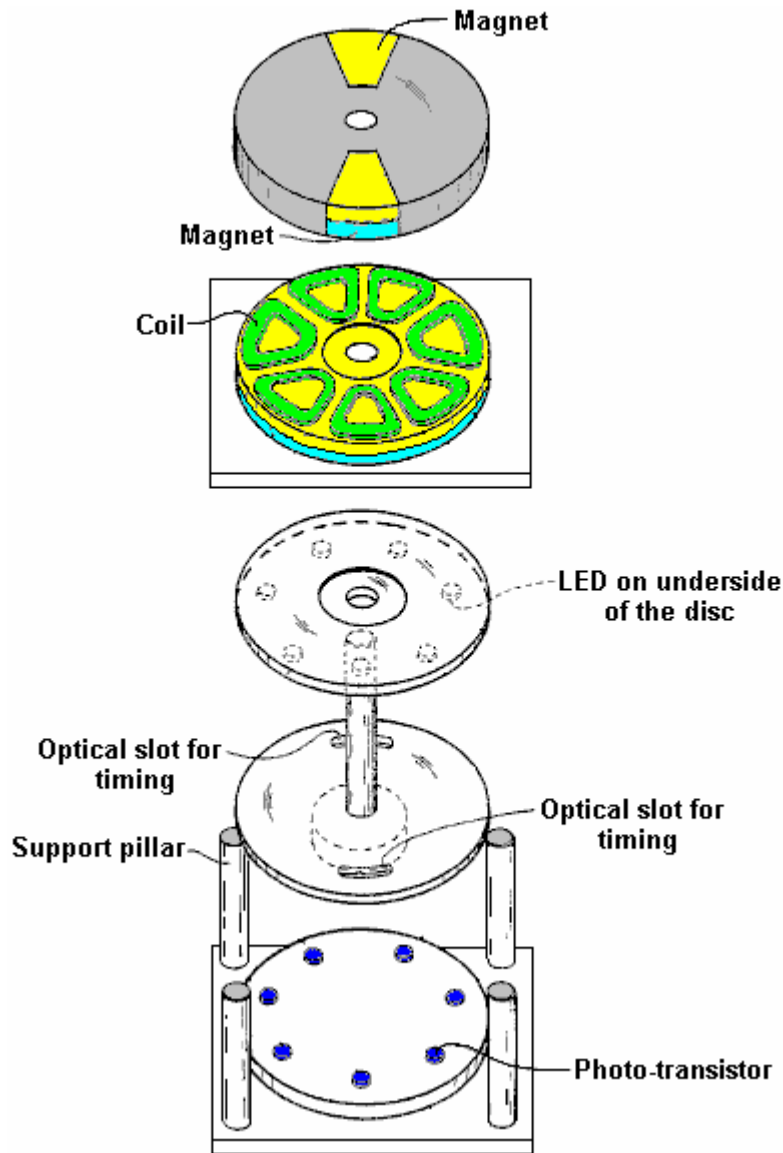

This construction is relatively simple and yet the operation is powerful. The power is provided by three magnets, shown shaded in blue and yellow. The lower magnet is in the form of a disc with the poles arranged on the large, circular, flat faces. This is the stator magnet which does not move. Positioned above it is a disc made of non-magnetic material (shaded in grey) and which has two magnets embedded in it. This disc is the rotor and is attached to the central vertical shaft.

Normally, the rotor would not rotate, but between the two discs there is a ring of seven coils which are used to modify the magnetic fields and produce powerful rotation. The powering up of these coils is very simple and it is arranged by shining a beam of Ultra Violet light from one of the Light-Emitting Diodes through a slot in an optical-timing disc attached to the rotating shaft. The LEDs and the photo-transistors are aligned with the centres of the seven coils. The position and width of the slot controls which photo-transistor gets switched on and for how long it remains powered up. This is a very neat and compact arrangement. The really interesting part of the design is how the coils modify the magnetic fields to produce the output power of the device. The orientation of the magnet poles can be swapped over, provided that this is done for all three magnets.

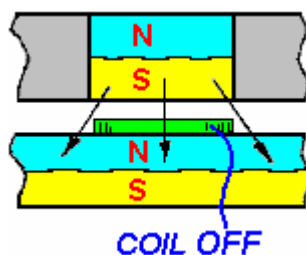

Shown here is the situation when one of the rotor magnets has rotated to where it is above one of the coils which is not yet powered up. The South pole of the rotor magnet is attracted to the North pole which is the entire upper face of the stator magnet as shown by the three arrows. If a voltage is applied to the coil, then this magnetic coupling is disrupted and altered. If any torque is developed as a result of the coil being powered up, then it will be developed to either side of the energised coil. If the coil is not powered up, then there will be full attraction between the magnets and no rotational force will be produced. You will notice that there are two rotating magnets (an even number) and seven coils (an odd number) so when one of the rotor magnets is above a coil, then the other isn't. This staggering of the two positions is essential for generating smooth, continuous rotational torque and self-starting without any need to rotate the shaft manually.

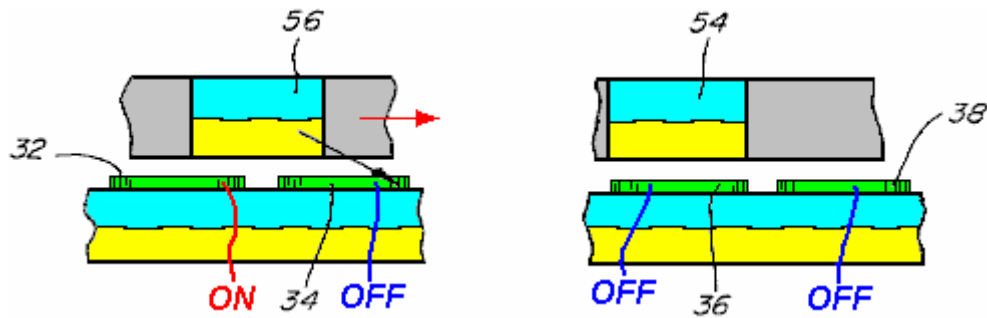

The diagram above shows a piece from both sides of the rotor disc, to explain the operation of the coils. On the left, magnet **56** overlaps coil **32** and coil **34**. Coil **32** is powered up and this breaks the magnetic link on the left hand side of magnet **56**. But, coil **34** is not powered up, so the attraction between magnet **56** and the disc magnet under the coils remains. Even though this attraction is at a downward angle, it creates a push on the rotor, driving it towards the right as shown by the red arrow.

While this is happening, the situation around the other side of the rotor disc, is shown on the right. Here, magnet **54** is above coil **36** and that coil is not powered up, so there is no resulting drive in either direction - just a downward pull on the rotor magnet, towards the stator magnet below it. The adjacent coil **38** is also not powered up and so has no effect on the rotation. This method of operation is **very** close to that of the motor design of Robert Adams described in the next chapter. It is important to understand that this method of operation is nothing like that of the John Bedini pulsers where the rotation of a disc is caused by the electrical pulse applied to a coil creating a repulsion thrust to a rotor magnet. Instead, here, the coil acts as a magnetic shield, being provided with the minimum possible power to do its job. The coil is, in effect, a shield which has no moving parts, and so is a very clever mechanism for overcoming the tendency for the rotor magnets to lock on to the stator magnets and preventing rotation.

At any moment, six of the seven coils in this design are inactive, so in effect, just one coil is powered. This is not a major current drain. It is important to understand that the power of this motor is provided by the permanent magnets pulling towards each other. Each of the two magnets applies a horizontal pull on the rotor every seventh of a turn, that is, every 51.1 degrees in the rotation. As the coils are an uneven number, the rotor gets a magnetic pull every 25.5 degrees in the rotation, first from one rotor magnet and then from the other rotor magnet.

It follows then, that the power of the motor can be increased by adding more magnets. The first step in this search for additional power is to add a second disc magnet and coils on the other side of the rotor, so that there is a second pull on the magnet. This has the added advantage that it balances the downwards pull of the first disc magnet with an upward pull, giving an enhanced and balanced horizontal thrust as shown here:

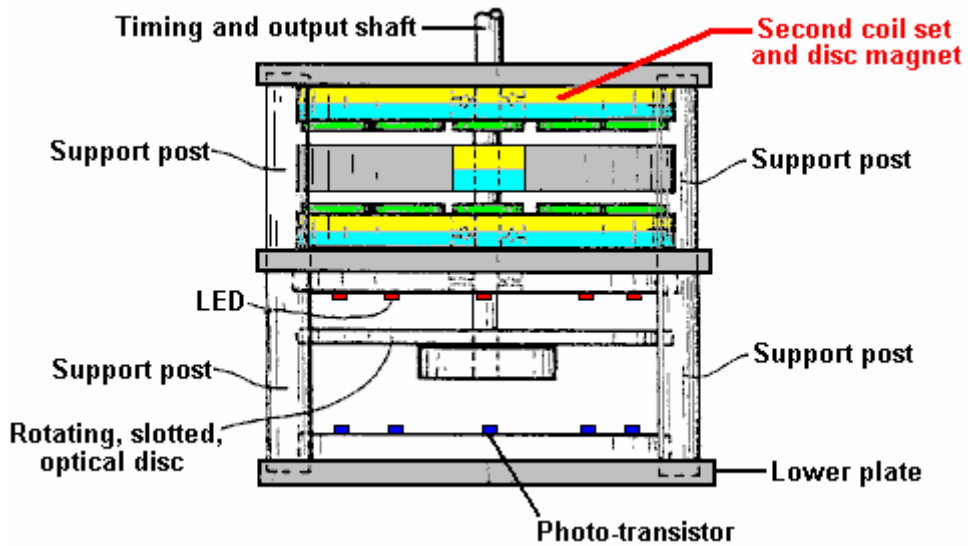

The coil switching with the additional layer of coils is shown here:

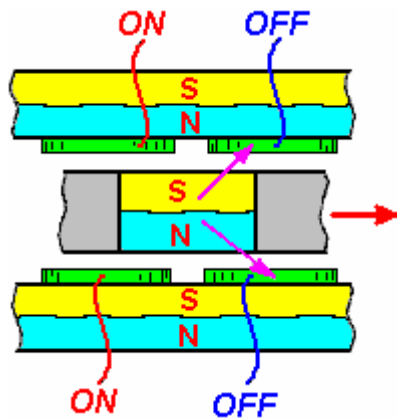

This produces a larger horizontal thrust. While this design goes for optimum performance, I suggest that a much more simple form of construction with a ring of standard circular neodymium magnets could be used instead of one large disc magnet, and ordinary circular coils placed on top of the circular magnets, and this allows large diameter rotors to be constructed, the larger diameter giving greater output shaft power:

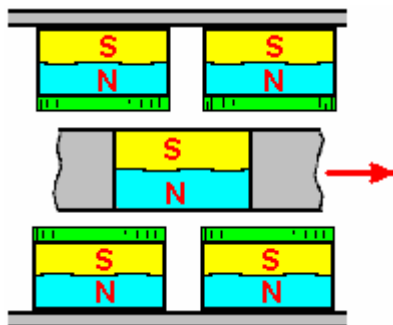

To increase the power of the output shaft further again, additional sets of magnets and coils can be added as shown here:

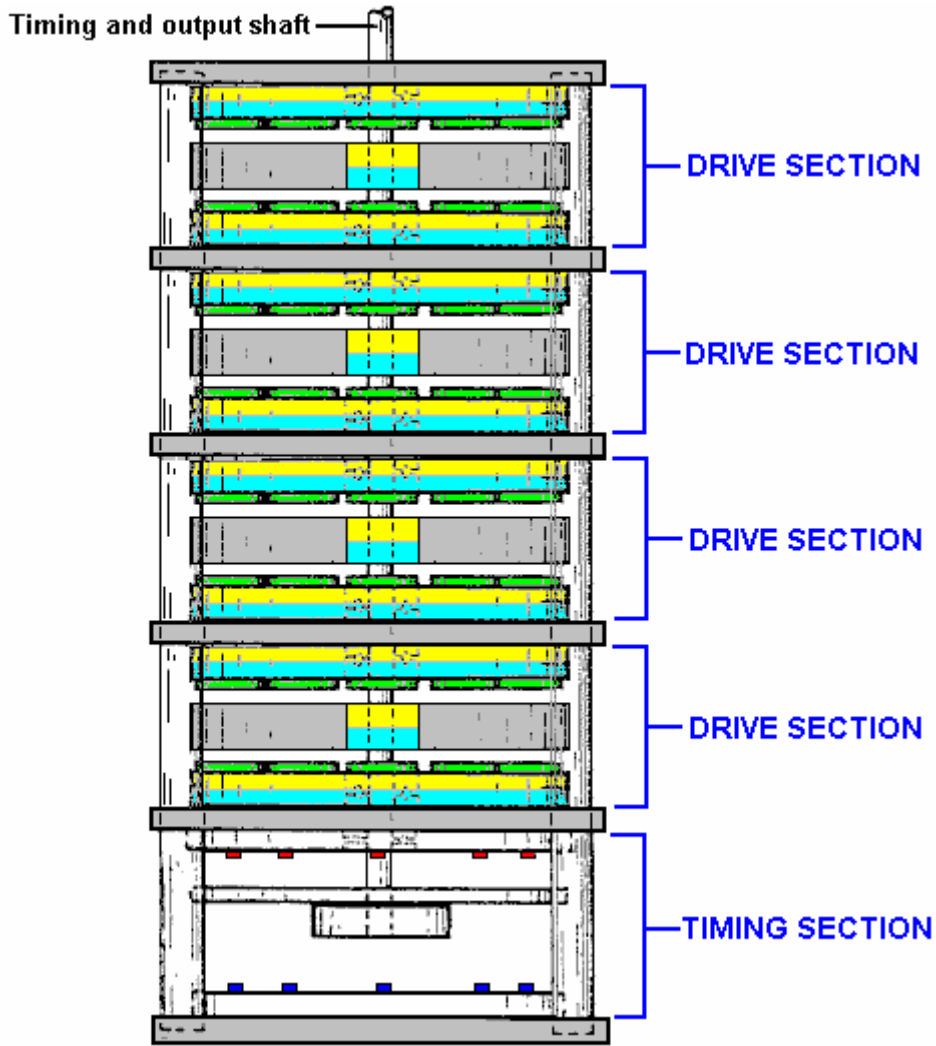

It should be remembered that the timing section shown above could be replaced by a NE555 timer circuit which generates a steady stream of On / Off pulses. When those pulses are fed to the coils, the motor rotates, slaving itself to the pulse rate. This gives an immediate speed control for the motor as well as avoiding the need for the precise positioning of the slotted disc which allows the LEDs to shine directly on to the phototransistors at the appropriate instant. If that approach is taken, then the timing section shown above would be omitted.

The circuitry that Charles specifies for powering the coils to block the magnetic fields of the permanent magnets uses N-channel MOSFETs and is very simple. Here is his circuit for driving one of the coils:

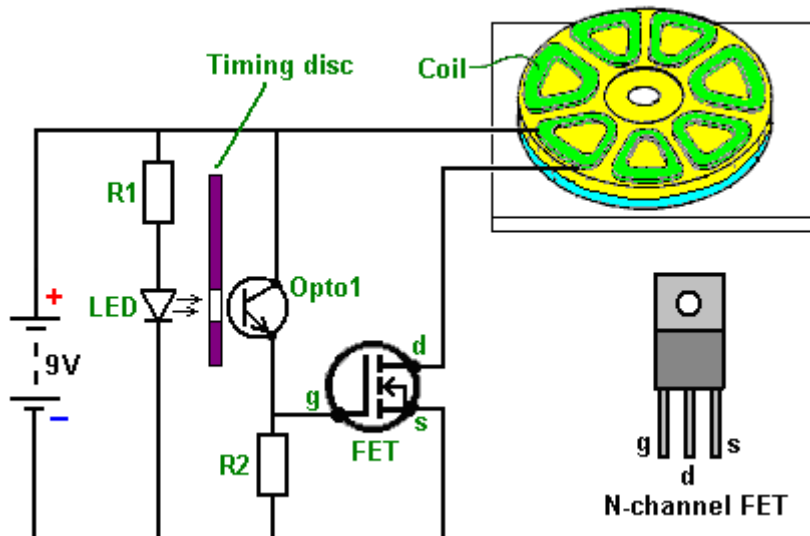

Just five components are used. The current through the coil is controlled by a transistor. In this case it is a Field-Effect Transistor usually called a "FET". The most common type of FET is used, namely an "N-channel" FET which is the rough equivalent to an NPN transistor as described in Chapter 12. A FET of this type is switched off when the voltage on it's "gate" (marked "g" in the diagram) is 2.5 volts or lower. It is switched on when the voltage on it's gate is 4.5 volts or more.

In this circuit we want the FET to switch on when the motor's timing disc is in the right position and be off at all other times. This is arranged by shining the light from a Light-Emitting Diode or "LED" through a hole in the timing disc which rotates with the shaft of the motor. When the hole is opposite the LED for the coil which is to be powered up, light shines through the hole and on to a light-sensitive device, Charles has opted to use a Light-Sensitive transistor, but a light-dependent resistor such as an ORP12 could be used instead. When the light shines on the "Opto1" device in the circuit diagram, it's resistance falls dramatically, raising the voltage on the gate of the FET and switching it on. When the timing disc hole moves past the LED, the light is cut off and the FET gate voltage drops down, switching the FET off. This arrangement causes the coil of the motor to be switched on and off at just the right time to give a powerful rotation of the motor shaft. In the circuit, the resistor "R1" is there to make sure that the current flowing through the LED is not excessive. The resistor "R2" has a low value compared to the resistance of "Opto1" when no light falls on it, and this holds the gate voltage of the FET down to a low value, making sure that the FET is completely off.

As you can see, this is basically a very simple circuit. However, as one of these circuits is used for each coil (or each pair of coils if there is an even number of coils in this slice of the motor), the circuit in the patent looks quite complicated. It is actually very simple. The resistor "R1" is used to limit the current flow through all of the LEDs used and not just one LED. You could, of course, use one resistor for each LED if you wanted to. The circuit for powering two coils (and not showing the timing disc) looks like this:

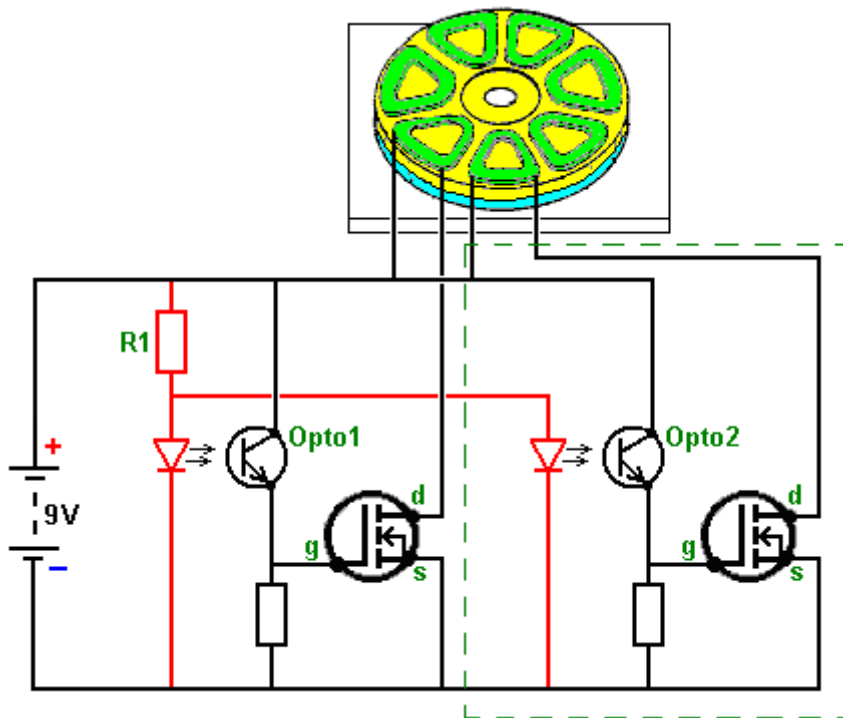

The section inside the green dashed line being the identical circuit for the second coil. This addition to the circuit is made for each coil, at which point, the motor is ready to run. If, as would be normal, several layers of magnets are being used, then the coils positioned above each other can be connected in a chain like this:

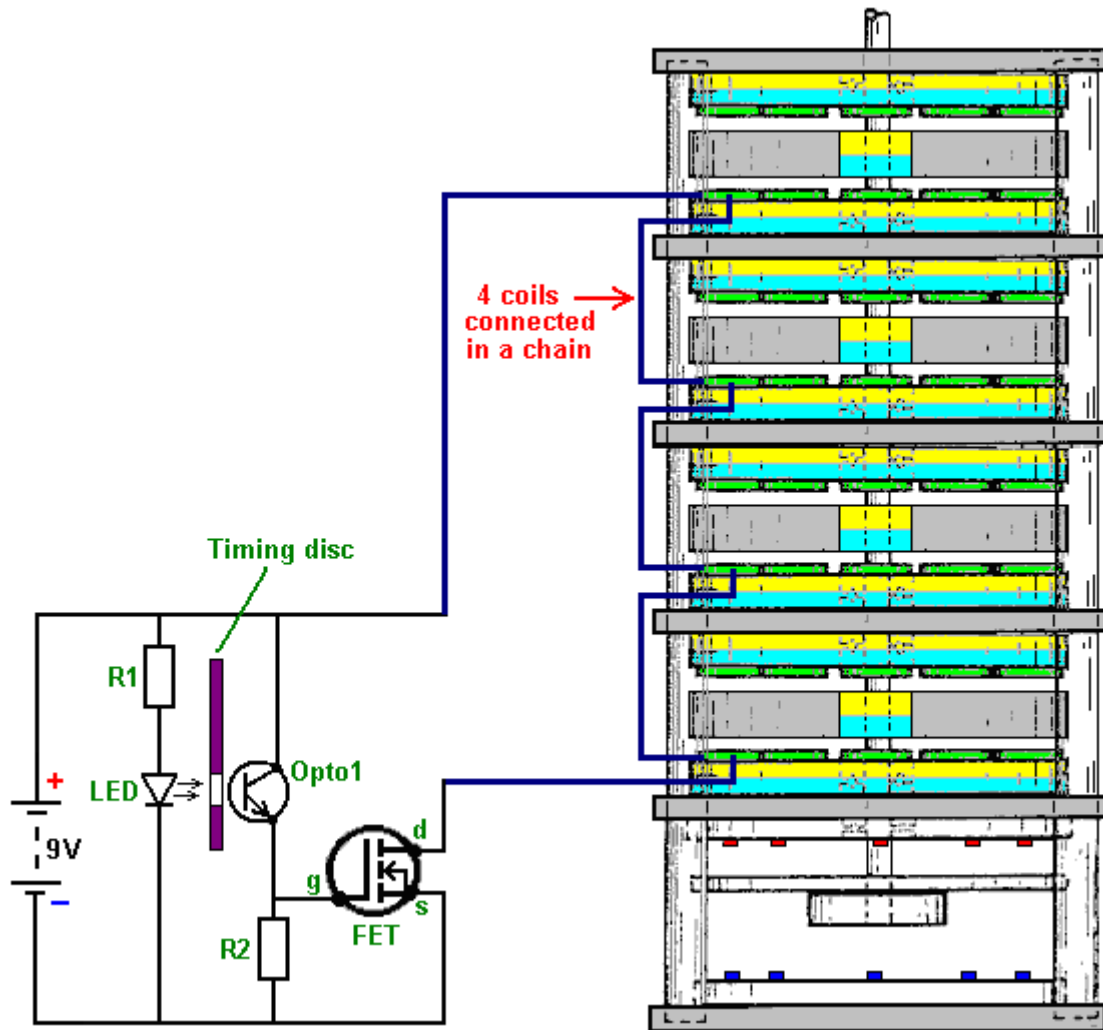

Connecting several coils "in series" (in a chain) like this, reduces the number of electronic components needed and it makes sure that the pulses to each of these coils is at exactly the same instant. Alternatively, it is possible to wire these coils across each other "in parallel", the choice is generally dictated by the resistance of the coils. The patent drawing shown above seems to indicate that there is a big gap between the LEDs and the optical devices. This is probably not the case as most people would choose to keep the gap between the LED and the light-dependent device as small as possible, mounting them so that they are just clear of the timing disc on each side of it.

In this patent, Charles Flynn remarks that this magnet motor can be used for almost any purpose where a motor or engine drive is required and where the amount of energy available or required to produce the driving force may vary little to nil. Charles has produced motors of this type which are capable of rotating at very high speed - 20,000 rpm and with substantial torque. Lesser speeds can also be produced, and the motor can be made to be self-starting. Because of the low power required to operate the device, Charles has been able to operate the motor using just a nine volt, off-the-shelf dry battery.

One application which seems most appropriate for this motor design is the Frenette heater shown in Chapter 14. Using this motor to drive the discs inside the heater drum would produce a heater which appears to be driven by just a nine-volt battery. However, while that is the appearance, the reality is that the power of this motor comes from the permanent magnets and **not** from the battery. The battery current is only used to prevent the backward pull of the magnets and it is **not** used to drive the motor.

While the use of a timing disc is a very satisfactory arrangement, it is also possible to use electronic circuitry instead of the mechanical timing disc, the opto devices and the LEDs. What is needed here is a device which produces a series of voltage pulses which can be used to drive the gate voltage of each FET from below 2.5 volts to over 4.5 volts. It looks as if the well-known 555 timer chip would be suited to this task and it would certainly run off the nine-volt battery. However, we have more than one set of coils which need to be run. For example, if we have say, four sets of coils to drive by powering up four different FET transistors one after the other, then we could use a "Divide-by-Eight" chip, like the 4022 chip. This chip can be set to divide by any number from two to eight. All that is needed to select the number to divide by, is one connection between two of the pins on the chip.

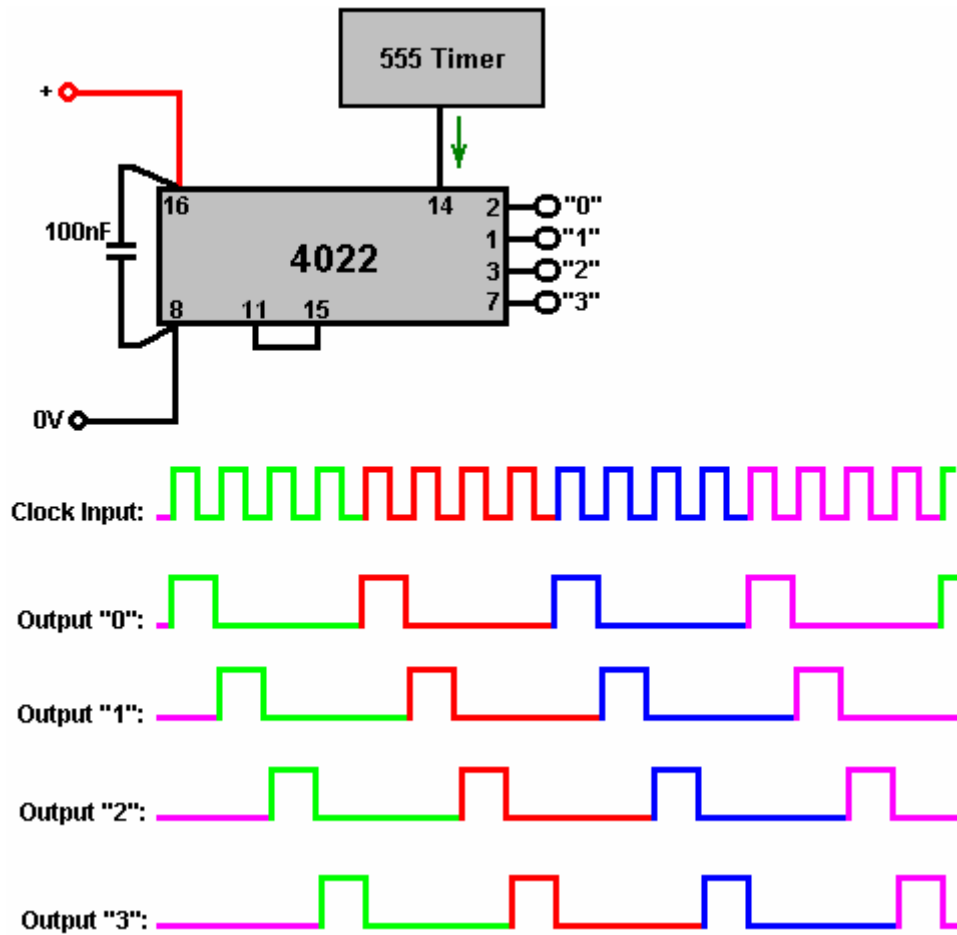

The output voltage on the pins marked "1", "2", "3" and "4" goes high one after the other as shown in the diagram above. So, each of these output pins would be connected to the FET gates in that order and the FETs would get switched on in that same order.

With the 4022 chip, the connections for the rate of division are as follows:

- For 'Divide by 7' operation, connect pin 10 to pin 15
- For 'Divide by 6' operation, connect pin 5 to pin 15
- For 'Divide by 5' operation, connect pin 4 to pin 15
- For 'Divide by 4' operation, connect pin 11 to pin 15
- For 'Divide by 3' operation, connect pin 7 to pin 15
- For 'Divide by 2' operation, connect pin 3 to pin 15

When using a circuit like this, the pulse rate from the 555 chip is set to a very low value like half a second, so that the motor shaft can get started. Once it gets moving, the pulse rate is gradually increased to speed the motor up. One advantage of this method is that it allows speed control, and if the motor was being used to power a Frenette heater, then the speed control would also act as a temperature control for the heater.

A possible 555 chip circuit might be:

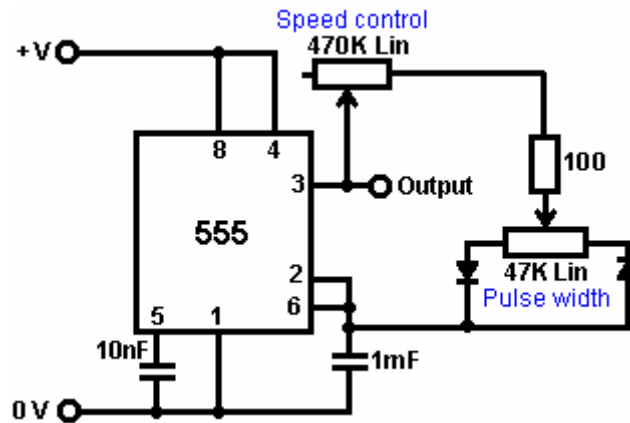

As this allows the speed to be controlled and when the required speed is reached, the pulse width can then be adjusted to give the minimum current draw to maintain that speed. There are, of course, many other suitable circuits which could be used instead of this one and Chapter 12 will fill you in on some of them as well as explaining how circuits work and how to build them.

If it so happens that it is difficult to find suitable circular magnets with the poles on opposing faces, then I suggest that it should be possible to use standard rectangular magnets throughout and rectangular coils as shown here:

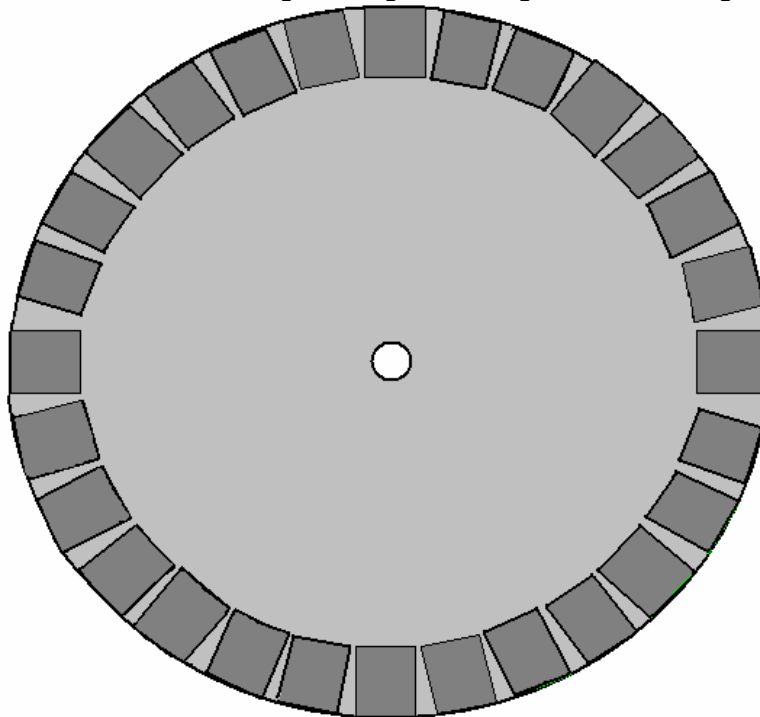

And while this arrangement is not as magnetically efficient as a circular magnet, it does have the convenience of allowing the construction of a rotor of any chosen size. Ideally, unlike the stator shown above, there should be an odd number of magnets, or failing that, an odd number of coils. Alternatively, the rotor could have an odd number of magnets so as to allow self-starting. But, it should be noted that if the motor is to be driven by an electronic pulsing system, then it is very much more simple to have an even number of magnets on the stator and start the motor moving by hand. This is because with an odd number of stator magnets, the opto sensors are not exactly opposite each other and so do not fire together. With an even number of stator magnets, the coils which are 180 degrees apart can be wired together as they fire at exactly the same time. With the slotted optical timing disc, the slots are exactly opposite each other and match the width of the rotor magnets, but the coils (nearly) opposite each other are not powered on and off at exactly the same time, although their powered arcs are likely to overlap for part of their operation. This could be catered for electronically by using a monostable delay for the coil on the opposite side of the disc.

The objective of each coil is to just, and only just, cancel out the magnetic field of the permanent magnet underneath it. The magnetic field produced by the coil depends on the current flowing in the coil, the number of turns in the coil and the area of the coil. The current flowing depends on the diameter of the wire and the voltage applied to it. It is probably necessary to mount just one magnet on the stator and experiment with the coil until

your current drive and coil allow the rotor to spin freely. Whatever the coil result is, should be ok for all of the magnets even though they are likely to vary in strength a bit.

Steorn's Magnetic Devices.

The Irish company Steorn have produced a system which is almost identical to the Charles Flynn magnet motor just described. They call their device "Orbo" and its operation is pretty much the same. The advance made by Steorn is that they have devised a very clever magnetic masking system using ferrite toroids wound with a copper wire coil. This is a slick method of switching magnetic attraction on and off. When the coil carries a sufficient current it generates a circular magnetic field spiralling around the toroid and not going outside the toroid. This field does not have an attraction for outside magnets. It makes no difference if the direction of the current flow through the coil is reversed as the resulting magnetic field just spins around the toroid in the opposite direction and performs exactly the same magnetic blocking of the ferrite ring which forms the toroid. If no current flows, then the copper wire does not block off the influence of the ferrite ring and the permanent magnets on the rotor are strongly attracted to it, causing the rotor to spin.

On their web site www.steorn.com, Steorn illustrate their design like this:

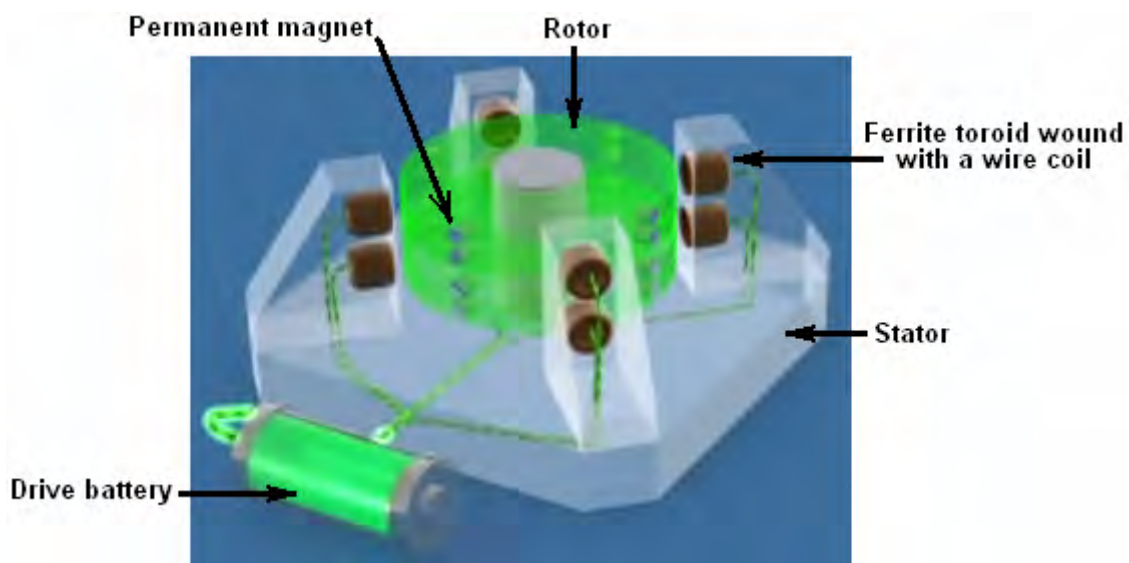

In this implementation, eight ferrite rings are mounted on the stator in four locations ninety degrees apart. These are wound with copper wire coils which can be powered by a battery, via a timing mechanism. The rotor has embedded in it, eight pairs of small permanent magnets, also spaced ninety degrees apart.

In exactly the same way as the Adams motor described in chapter 2, the current through the coils is set to the minimum level which allows the rotor to spin freely. The timing mechanism is then switched in and the motor and the rotor given a spin. The rotor magnets are strongly attracted to their corresponding ferrite rings mounted on the stator posts and this accelerates the rotor.

If no current is passed through the coils, then the rotor will oscillate backwards and forwards for a short time before coming to rest with the magnets as close to the ferrite rings as possible. To prevent this happening, the timing circuit senses when the magnets reach the ferrite rings, and passes that minimum current through the coils, trapping the rings inside a magnetic field which has no effect on the rotor magnets. The momentum of the rotor causes it to spin on past the stator rings to a position where the magnets are closer to the next rings than they are to the ones which they have just passed, at which point, the current is cut off and the magnetic attraction to the ferrite rings returns. This is identical to one mode of operation of the Adams motor.

The next step is also identical to that of the Adams motor, namely, to add on some pick-up coils to convert some of the rotating magnetic energy into electrical energy, either to recharge the driving battery or to power other equipment, or both.

Steorn's arrangement for doing this is to add an additional disc, containing permanent magnets, to the rotor and positioning wire coils opposite those magnets as is normal for a generator. Steorn choose to show the resulting energy charging up the battery again:

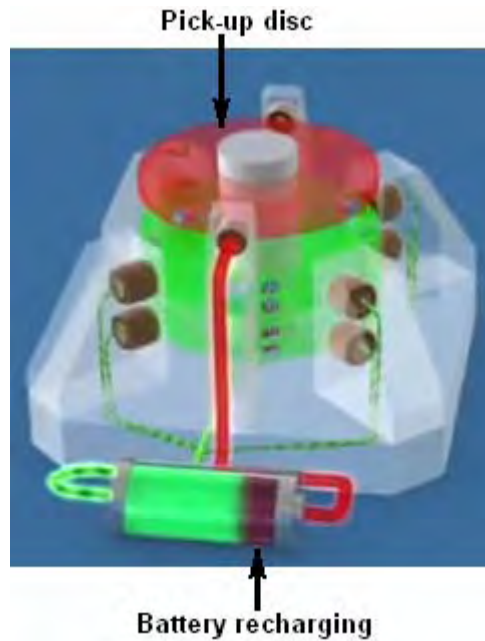

Video presentations on this style of motor/generator are at:
<http://www.youtube.com/watch?v=AXamGLyRkt8&NR=1>
<http://www.youtube.com/watch?v=rg3rLqYMzN4&feature=related> and
<http://jnaudin.free.fr/steorn/indexen.htm>

We tend to think of this style of magnet-powered motor as being low-power. This is probably because it is often the case that the demonstration proof-of-principle implementations shown are minor devices. These motors can be very powerful and the one shown here, designed and built by Mr Sung of China has an output power of 20 kilowatts or twenty-seven horsepower:



And another design which has a larger diameter and about 144 magnets has a reported output of 225 horsepower:

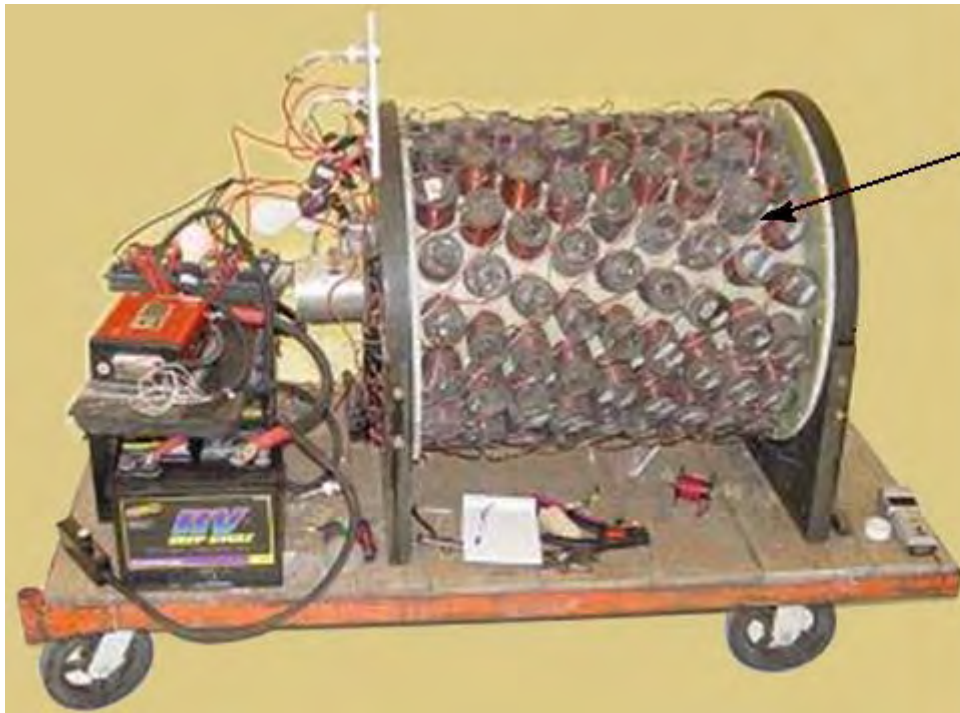

Electromagnets
(can also act as
pick-up coils)

You will notice that each ring of magnets is positioned further around the rim of the cylinder providing powerful pulses from 64 magnets every 22.5 degrees of rotation, so it is little wonder that the motor has considerable shaft power. Some of the coils can be switched to collect power if the working conditions do not need the full shaft output power, charging the drive battery. The rotating inner cylinder has permanent magnets mounted on it.

George Soukup's Permanent Magnet Motor.

There used to be a video on the web, showing a magnet motor built on the "V" style of magnet placement which has two sets of permanent magnets spaced like this:

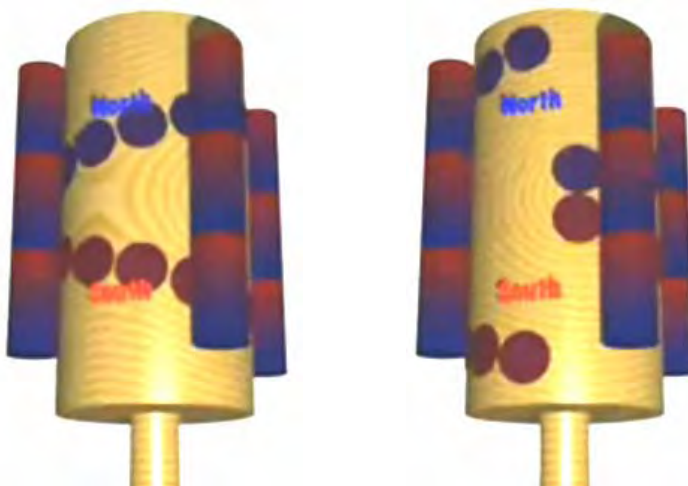

This style of magnet arrangement (North magnets shown in blue and South in red) has a locking point where the switch from wide spacing to narrow spacing occurs and this causes the rotation to stop there.

The implementation shown in this video has the V magnets spaced rather more widely apart as shown here:

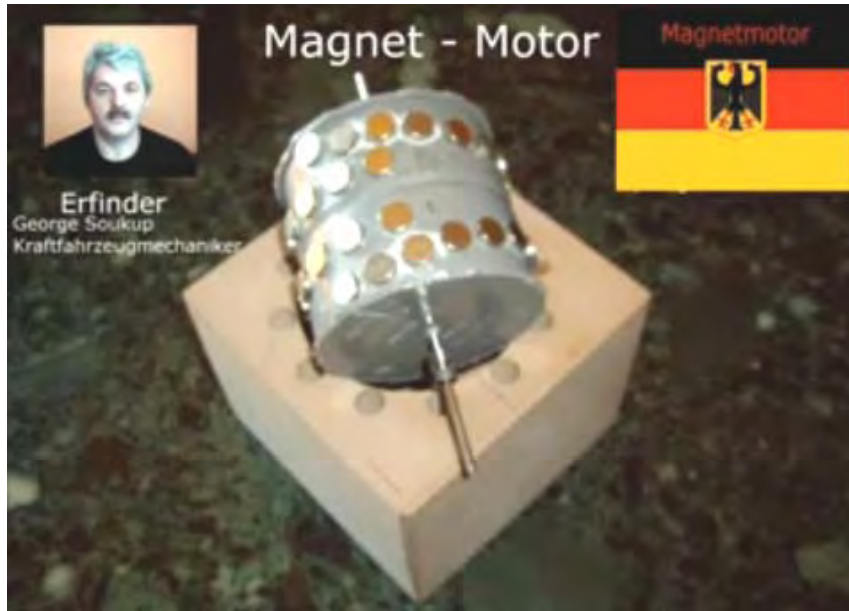

The taper is much less pronounced with an inner gap some four times greater than the gap to the outer ring. It also appears that the last inner magnet has a greater gap around the drum than the remaining ring of magnets.

The housing is very simple looking, with an evenly spaced ring of twelve holes to take long magnets with alternating North and South magnetised areas along their length. You will notice from the photographs, that George has cavities to take up to twelve stacks of stator magnets, although he only uses any five of them for his demonstrations.



The housing has considerable clearance for the drum and magnets. The rear shaft bearing is just set into the back of the housing:



The front has two sheets of acrylic, one to hold the insert magnets in place and one to provide the shaft's front bearing support:



As there is no commentary with the video it is a little difficult to pick up all of the details, but it seems that positioning stator magnets allows the motor to overcome the normal sticking point of the typical V-motor arrangement. The video shows various arrangements including the non-symmetrical grouping shown here where four or five consecutive magnets are used and the remaining slots left empty:

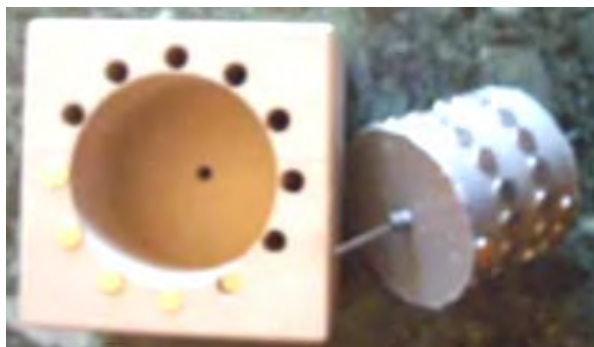

Dietmar Hohl's Permanent Magnet Motor

If you would like to make a simple motor of this type, then the information provided by Dietmar Hohl, passed to me by Jes Ascanius of Denmark, shows you how. He uses 20 mm diameter round neodymium magnets 10 mm thick, stacked in pairs in the stator of this layout:

Permanent Magnet V-Accelerator Field Design by Dietmar Hohl 6th April 2007

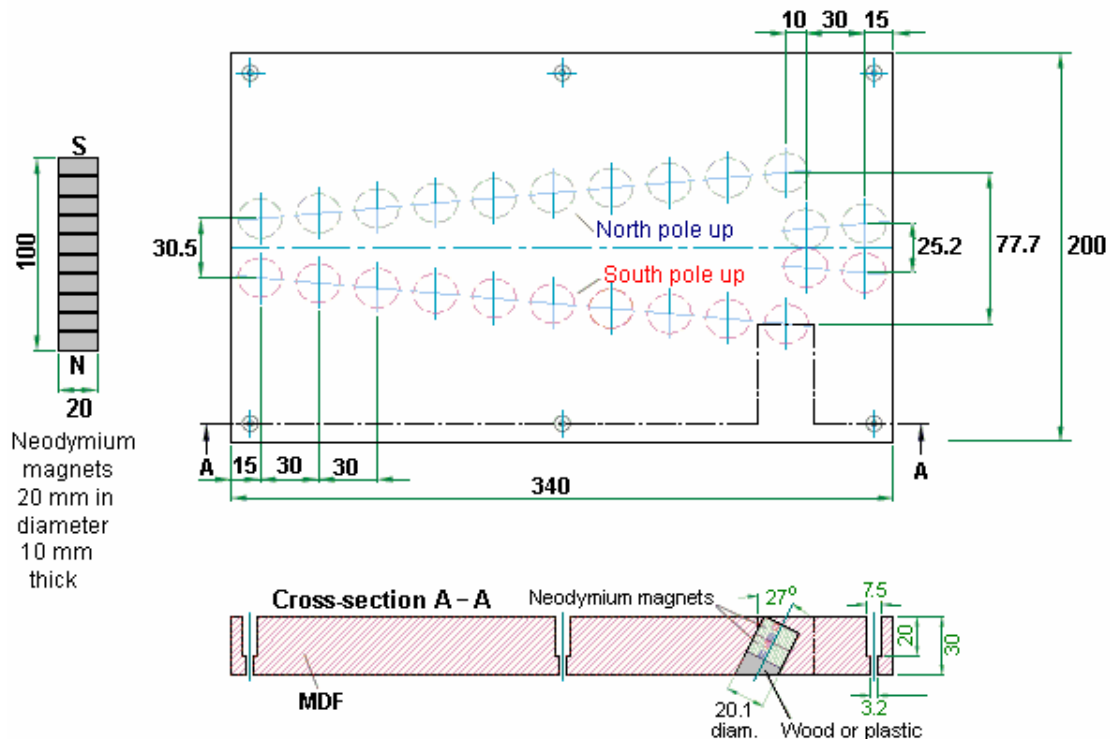

This shows a magnetic gate arrangement built on a flat piece of Medium-Density Fibreboard 30 mm thick. The holes drilled in it are 20.1 mm in diameter and positioned so as to take two of the 10 mm thick magnets stacked together. The holes are drilled at an angle of 63 degrees to the horizontal or 27 degrees to the vertical, whichever way you prefer to think of it. On one side of the board, the inserted magnets have their North poles facing upwards, while on the other side of the board, the magnets are inserted with their South poles facing upwards. Dietmar shows six holes to take bolts or screws to fasten the piece of MDF to a larger board or table. Those do not form any part of the magnetic system and can be omitted. A video of one version of it in action can be found at <http://www.free-energy-info.tuks.nl/Vtrack.mpg>.

The gate operates by causing a stack of ten of the magnets to roll along the V-shaped track and pass smoothly across the junction with the next set of V-positioned magnets. There can be as many of these V-sets as you want and the magnet stack will still keep rolling. This is one of the few magnetic gate designs which adapts to drum operation as a motor rotor.

The magnets are positioned at an angle in order to use the magnetic fields at the edge of the magnets. They are stacked in pairs in order to increase their power. The power of the motor depends on the strength of the magnets, how close the stator magnet stacks are to the VF-track magnets and the number of stacks of stator magnets. If you decide to construct one of these motors, then it is suggested that you make things easier for yourself by keeping the curvature low, using three or four of the Vs. With Dietmar's dimensions, a 2-V drum would be 216.5 mm (8.5") in diameter, a 3-V drum would have a 325 mm (12.8") diameter and a 4-V drum a diameter of 433 mm (17") and those dimensions include the 30 mm (1 3/16") strip which holds the magnets, so the inner drum diameters are 30 mm less in each case.

When making the motor drum, it is possible to use a flexible material to hold the magnets. This allows the strip to be laid out flat while the holes are drilled, and then attached to the outside of a rigid drum with a 60 mm lesser diameter than the ones mentioned above. Jes Acanius of Denmark shows how a jig can be made to make drilling the holes easier:

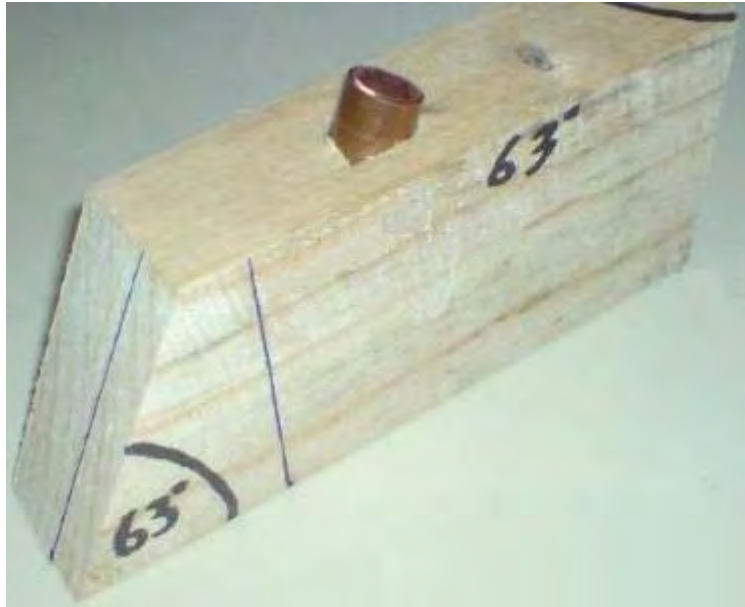

This one has had a length of copper pipe inserted at the correct angle, in order to direct the drill bit at the exact angle required. This motor has been successfully replicated by Jes Ascanius of Denmark who used 10 mm magnets which were to hand, and again with square magnets which were pushed into round holes and not even angled in this proof-of-concept implementation which only took one hour to build using scrap material to hand, and which did work:



With Dietmar's design using angles magnet pairs, the number of magnets needed is quite high. For a single V, there are 58 magnets. For a 2-V version, 106 magnets. For a 3-V version, 154 magnets and for a 4-V version, 202 magnets if there is only one stack of stator magnets, so ten extra magnets need to be added to the count for each additional ten-magnet stack of stator magnets. The motor power is likely to increase as the diameter increases as the lever arm that the magnet has to turn the drum, increases – double the diameter to (almost) double the power.

Simple Permanent Magnet Motors

It is very difficult to use the power of permanent magnets to make a motor powered by them alone. The Dietmar Hohl design shown above is one of the very few which can readily be made and tested at home. The problem is that almost all magnets have a symmetrical magnetic field, while what is needed for a magnet-powered motor is an asymmetrical magnetic field. Consequently, magnets have to be combined in ways which distort their normal field shape. You will notice that in the Hohl motor, the drive magnets are angled and that is an important feature of using magnets in motors.

Schools currently teach that the field surrounding a bar magnet is like this:

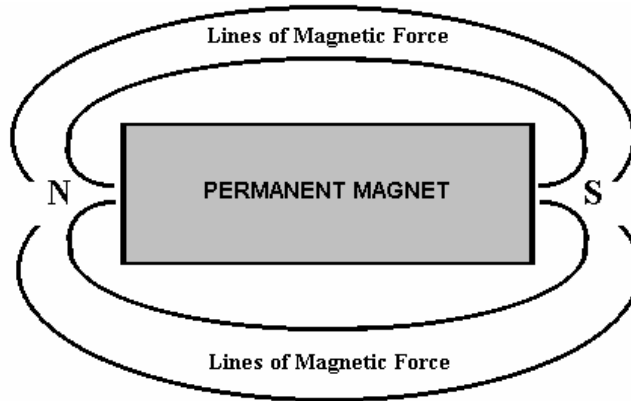

This is deduced by scattering iron filings on a sheet of paper held near the magnet. Unfortunately, that is not a correct deduction as the iron filings distort the magnetic field by their presence, each becoming a miniature magnet in it's own right. More careful measurement shows that the field actually produced by a bar magnet is like this:

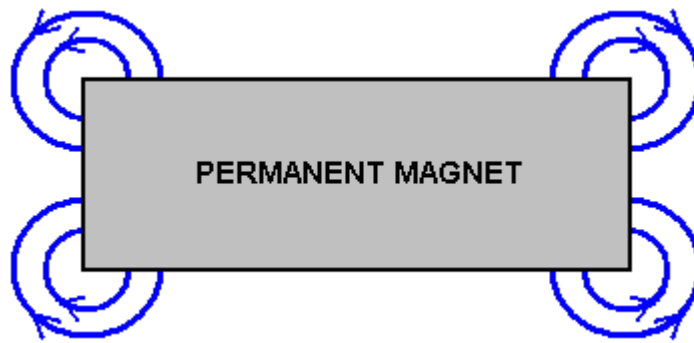

There are many lines of force, although these diagrams show only two of them. The important factor is that there is a rotating field at each corner of a typical bar magnet. It follows then that if a row of magnets is placed at an angle, then there will be a resulting net field in a single direction. For example, if the magnets are rotated forty five degrees counter clockwise, then the result would be like this:

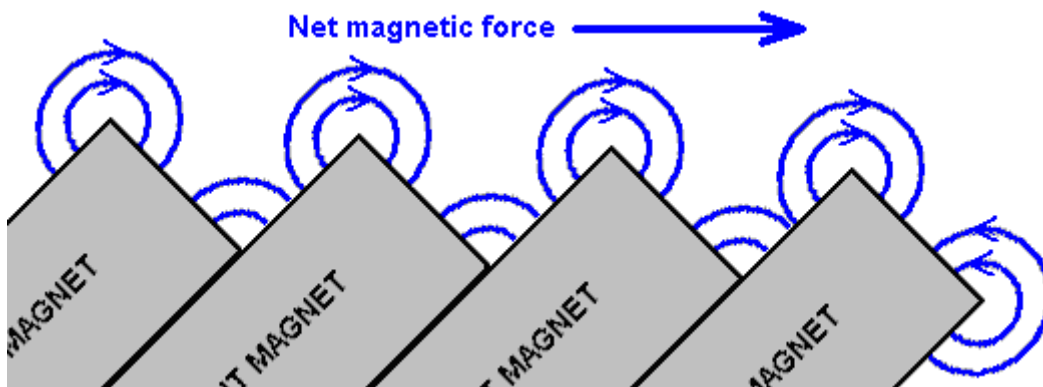

With this arrangement, the opposing corners of the magnets as shown here, are lower down and so there should be a net magnetic force pushing to the right just above the set of magnets. However, the situation is not as simple and straightforward as you might imagine. The additional lines of magnetic force which have not been shown in the diagram above, act further out from the magnets and they interact, creating a complex composite magnetic field. It is frequently found that after four or five magnets that a short gap needs to be left before the line of magnets is continued on.



Two boys; Anthony and Andreas, have used this magnet arrangement to create a magnetic track and they have a lot of fun, sending a magnet sliding between two of these rows of angled magnets. Initially, they used the cheaper ceramic magnets and got a very satisfactory movement when using a neodymium magnet as the moving component:

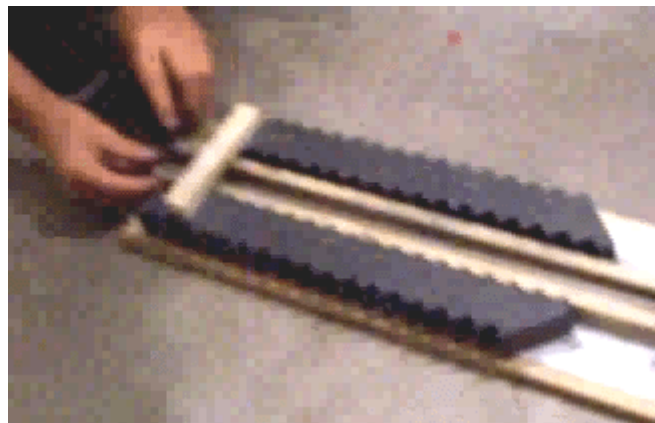

You will notice that they have managed a row of 18 ceramic magnets on each side of their track and the results which they are getting are very good. They have three videos on the web at the present time:

<https://www.youtube.com/watch?v=Vo2-Qb3fUYs>

<https://www.youtube.com/watch?v=VeXrFfw4RSU>

https://www.youtube.com/watch?v=VTbFfEEE_qU

The moving magnet is made up of four 12 mm x 12 mm x 12 mm (or half-inch by half inch by half inch) neodymium magnets attached North - South - North - South - North - South - North - South:



They have not disclosed all of the details of what they are using (accidentally rather than by intention). The ceramic stator magnets are 48 mm x 20 mm x 10 mm with the poles on each of the main faces. They position each magnet with its North pole facing towards the track and they angle the magnets at 45 degrees. There is a 15 mm gap between the stator magnets and the moving magnets on both sides of the track. Wooden strips direct the moving magnets.

Neodymium magnets have very different characteristics to those of ceramic magnets (and that is not just strength of the magnetic field). It is not unusual for experimenters to find that devices will work well with one type of magnet but not with the other type. Here the developers have also tried using two sets of five angled neodymium magnets on each side of their track and the result was a more powerful thrust on their moving magnets.



The magnets are held in place in this picture, by wooden dowels driven into the base plank. They used these in order to avoid any magnet-fastening material which could alter the magnetic field.

The next step would be for them to power a motor using their magnetic track technique. However, this has been tried many times and the conclusion is that it is **VERY** hard to change a straight magnetic track into one which forms a complete circle. Therefore, I would suggest the following arrangement:

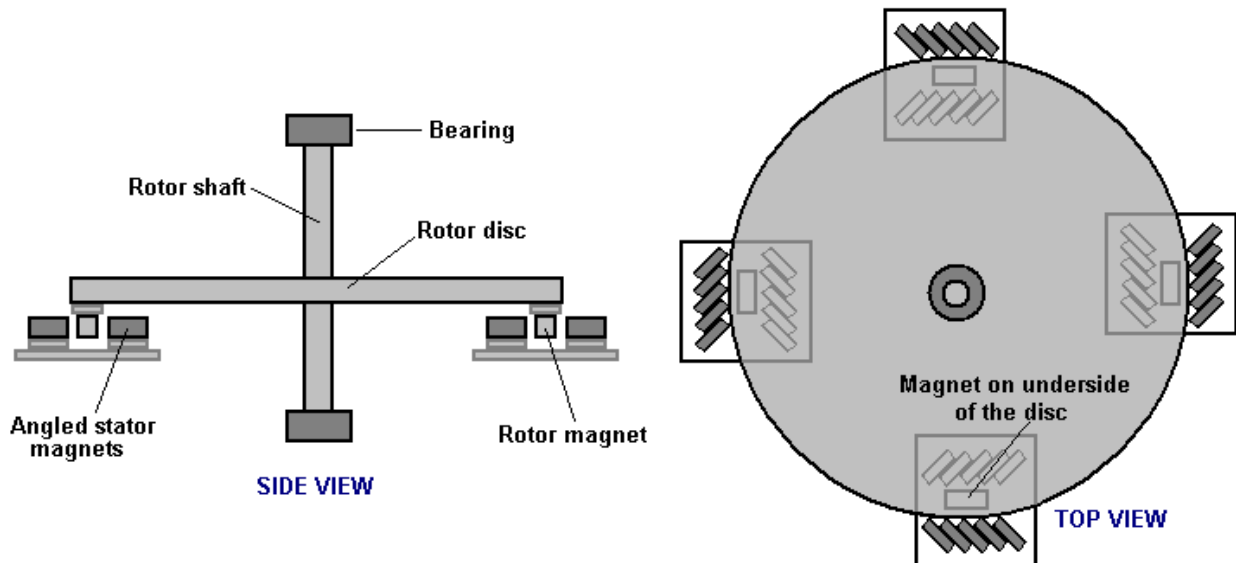

Here, a simple disc rotor has four magnets (of the type used to move down the magnetic track) attached to the underside of the disc and positioned so that they move through four short sets of four, or at the outside, five angled stator magnets as the disc spins. It does not matter if the rotor shaft is horizontal or vertical. If the disc spins well, then sets of two air-core pick-up coils can be positioned between each of the stator magnet arrays so that electricity is generated as the rotor magnets pass by overhead. If a constructor decides to attach two rotor discs to the one rotor shaft, then the two rotors should be positioned so that the rotor shaft gets pushed every 45 degrees of rotation rather than every 90 degrees as shown here. This style of motor is definitely within the scope of the average person to build should they be inclined to do so.

I have been asked to say how I personally would go about constructing a prototype of this nature. As I have very limited constructional skills, I would do it like this:

For the bearing, I would pick a computer cooling fan, as these have very good bearings and if one is not to hand inside an old, obsolete computer, then they can be bought very, very cheaply. The diameter of the fan is not important. These fans generally look something like this:



As the part of the fan which spins round does not normally project above the stationary frame, a spacing disc of wood or plastic is needed to provide the clearance. The disc is glued to the centre of the fan using perhaps, Impact Evostick, epoxy resin or super glue. It would then look like this:

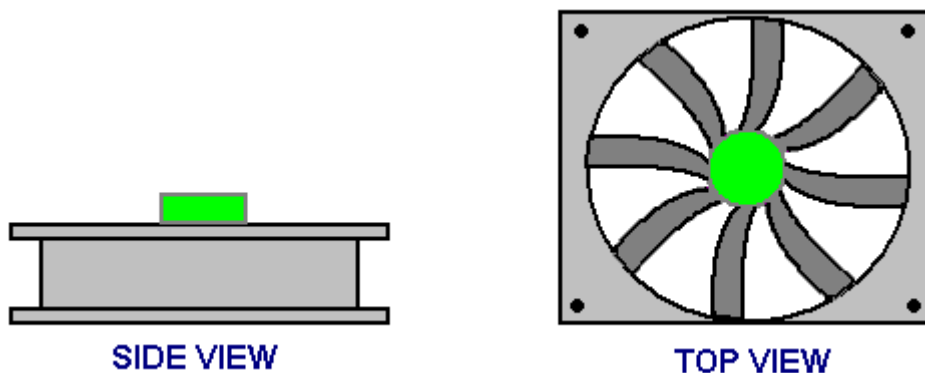

A square of wood can then be screwed to the spacer, like this:

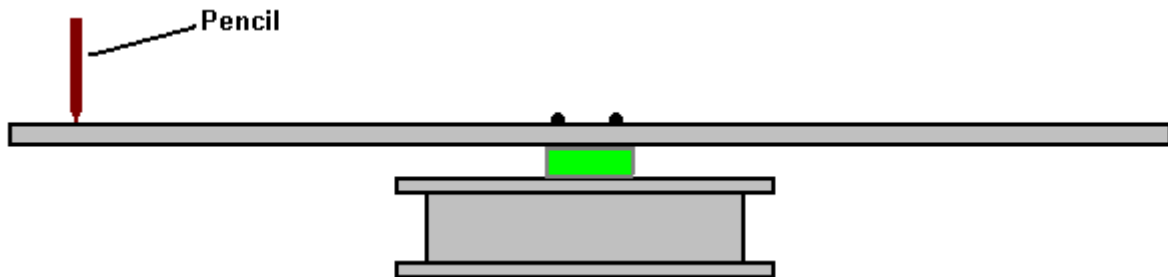

And as I am hopeless at creating good-quality mechanical devices, I would then hold a pencil very steadily against a support and give the wood a spin, so that the pencil draws a perfect circle exactly centred on the bearing of the fan. Then, marking the wood and the spacer so that there is no doubt as to which way round the wood is attached to the spacer, I would unscrew the wood and cut around the pencil line very carefully, smoothing the edges of the disc gently with fine sandpaper. Screwing the disc back in place, a spin should confirm that the edge of the disc stays steadily in place with no wavering of the edge. Actually, if the disc is not perfect, that is not a major problem as it is the rotor magnets which need to be positioned accurately, and for that, another pencil line can be produced by spinning the disc when the desired position has been determined.

Permanent magnets vary enormously in size and strength, so when magnets are purchased, it is a matter of testing them using a track of the type used by Anthony and Andreas. The stator magnets are angled at about 45 degrees to the track and with just four on each side, it is a case of finding the spacing between the two sets of angled magnets which pushes the stator magnets furthest along the track.

Muammer Yildiz's Permanent Magnet Motor.

Muammer Yildiz has developed a powerful permanent magnet motor, patented it, and demonstrated it to the staff and students of a Dutch university. During the demonstration, the mechanical power output was estimated at 250 watts and immediately after the demonstration, the motor was completely taken apart to show that there were no hidden power sources. There is a video showing this demonstration, located at:

http://pesn.com/2010/04/22/9501639_Yildiz_demonstrates_magnet_motor_at_Delft_University/



Please note that this is an attempted translation of the German language text of his patent and so, the accuracy of the content is not absolutely certain although it is likely to be reasonably accurate.

Patent EP 2,153,515

17th February 2010

Inventor: Muammer Yildiz

DEVICE HAVING AN ARRANGEMENT OF MAGNETS

ABSTRACT

The device has a rotating axial drive shaft **5** supported so that it rotates inside a stator **2**, which is surrounded by an outer stator **3**. The rotor is firmly connected to the drive shaft. The outer stator has dipole magnets **6** which are positioned on the inner surface of a circular cylinder **9**. These outer magnets are evenly spaced around the surface of the surrounding cylinder.

DESCRIPTION

This invention is a device for generating an alternating magnetic field that interacts with a stationary magnetic field. The interaction of a stationary magnetic field with an alternating magnetic field has been used for some time, for example in brushless DC motors and in magnetic levitation.

One object of this invention is to provide an improved device for generating an alternating magnetic field that interacts with a stationary magnetic field. This is achieved as described in Claim 1, by the special arrangement of the dipole magnets of the inner stator, the rotor and the outer stator which creates a magnetic effect which keeps the rotor floating freely between the inner stator and the outer stator, and this acts as a magnetic bearing.

Surprisingly, it has been shown that the special layout of the dipole magnets of the inner stator, the rotor and the outer stator during rotation of the rotor, generates an alternating magnetic field which allows a largely loss-free movement of the rotor as it spins between the inner stator and the outer stator. This very useful effect can be used for a variety of technical applications, for example, a particularly low-friction bearing is preferred for supporting a shaft which has to rotate at high speed.

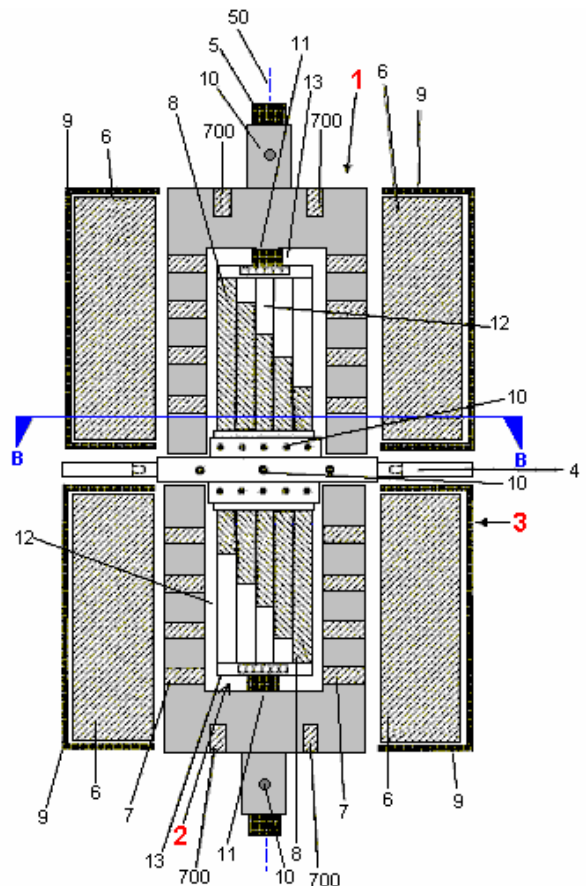

In the following description, when mathematical terms, especially geometric terms, are used - terms such as "parallel", "perpendicular", "plane", "cylinder", "angle", etc. as is typical when producing technical drawings, but it must be understood that these things are never achieved in practice, due to the manufacturing tolerances of the components. It is therefore important to realise that this description refers to the ideal situation, which will never be achieved. Therefore, the reader needs to understand that generally accepted tolerances will be involved in practice.

The output shaft spins around one axis, called the "shaft axis". The shaft itself is preferably constructed as a straight cylinder of circular cross-section.

In a preferred embodiment of this invention, the magnets project slightly out of the inner stator. This is also the case for both the rotor and the outer stator. A partial overlap of two magnets is achieved when a plane perpendicular to the shaft axis, passes through both of the two magnets and the two magnets are considered to overlap if this situation occurs.

A partial overlap of three magnets occurs when a plane perpendicular to the shaft axis runs through each of the three magnets. The degree of overlapping does not affect the description and the amount of overlap of any two of the three magnets can be anything from 1% to 100%, where the magnets overlap completely.

In a particularly preferred embodiment of the invention, the magnets of the inner stator and the rotor are able to align completely. In addition to this, the outer stator is constructed so that it can be rotated around the shaft axis so that the contact ratio between the magnets of the rotor and the magnets of the outer stator can be adjusted to give any degree of overlap from 0% to 100%.

Three imaginary cylinders are produced. One by the magnets of the inner stator, a second by the rotor magnets as they spin around the shaft axis and the third is created by the magnets of the outer stator. The axes of these three cylinders is the same as the shaft axis.

Ideally, the rotor will have the shape of a drum or a cup, that is, a hollow cylinder with a circular cross-section or a piece of pipe whose one end face is covered by circular disk. In the centre of the disc, the rotor has a hole through which the shaft passes. The disc can also have a collar which is used to clamp the rotor to the shaft by means of a bolt passing through the drive shaft or by grub screws tapped into the collar. Whichever method is used, the rotor magnet assembly is connected securely to the drive shaft. The use of a clamping screw has the advantage of allowing the rotor to be taken apart for maintenance or repair. The hollow cylinder section of the rotor, is arranged so that there is a small air gap between it and both the inner and outer stators.

The hollow rotor cylinder has two, or more, permanent magnets mounted on it. These are equally spaced around the circumference of the rotor cylinder and positioned so as to be parallel to the drive shaft axis. The outer stator is cylindrical in shape and surrounds the rotor, leaving a small air gap between them and it's axis is aligned with the drive shaft axis. Ideally, the magnets mounted on the inside of the outer stator cylinder, are aligned with the drive shaft axis and their pole faces are at right angles to the shaft axis. That is, a line drawn through the North and South pole faces of these magnets will point at the drive shaft, and so one pole face will face the rotor.

It is also possible for the magnets of the outer stator to be rod-shaped and to form a complete ring around the inner face of the outer stator cylinder. If this is done, then the magnetic rings need to be separated from each other by non-magnetic spacers and the whole length of the outer stator will be covered with these magnetic rings and spacers. In this case, the inner and outer stators are mounted in a fixed relationship to each other by means of brackets or other mounting methods.

Ideally, the rotor is held in position by the magnetic fields of the two stators and "floats free" between them. This is the preferred method. However, it is possible for the drive shaft to run the entire length of the device and to be supported in roller bearings.

One possible construction is to have both of the stators made in two separate parts. These need to be exactly symmetrical relative to the drive shaft axis. The outer stator pieces can also be arranged to be capable of rotational adjustment relative to the inner stator which always has a fixed position. Another option with this particular arrangement is to have the distance of the outer stator components adjustable, so that the air gap between the rotor and the outer stator magnets can be manually adjusted.

An angle "alpha" is defined as the angle between the magnetic axis of a magnet of the inner stator and a tangent to the circumference of the inner stator at that point. An angle "beta" is defined as the angle between the magnetic axis of a rotor magnet and a tangent to the rotor circumference at that point. An angle "gamma" is defined as the angle between the magnetic axis of a magnet of the outer stator and a tangent to the circumference of the outer stator at that point. In a preferred embodiment of this invention, each of these angles

is between 14 degrees and 90 degrees.

It is a particular advantage if the permanent magnets of both the inner and outer stator have a either a rectangular or trapezoidal cross-section when seen as being cut by a plane perpendicular to the shaft axis. It is also particularly advantageous if the rotor magnets have a circular cross-section when viewed as being cut by that plane perpendicular to the shaft axis. Other, non-symmetrical magnet cross-sections are possible, such as trapezoidal, triangular, or irregularly shaped cross sections.

It is possible for all of the magnets of the inner stator to have identical shapes. Similarly, it is possible for all of the magnets of the outer stator to have identical shapes. It is also possible for all of the rotor magnets to have the same shape. However, the positioning of the magnetic North and South poles of the various magnets will not be identically position as will be seen from the following detailed description.

The magnets of the inner stator, the rotor and the outer stator have a magnetic orientation which causes them to repel each other at every angular position of the rotor. For example, the magnets of the inner stator can have their North poles facing outwards and in that case, the magnets on the rotor will have their North poles facing inwards towards the inner stator. Similarly, the magnets of the outer stator would then have their South poles facing inwards in order to repel the (outer) South poles of the rotor magnets.

Further features, details and advantages of the invention will be apparent from the following description of an embodiment of the invention and the associated drawings as shown here:

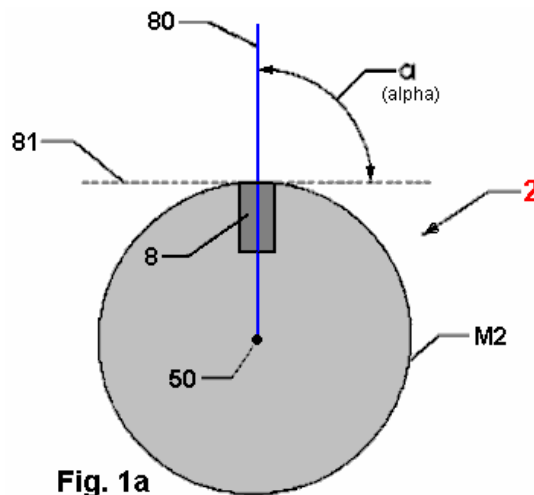

Fig. 1a

Fig.1 is a schematic representation of the device.

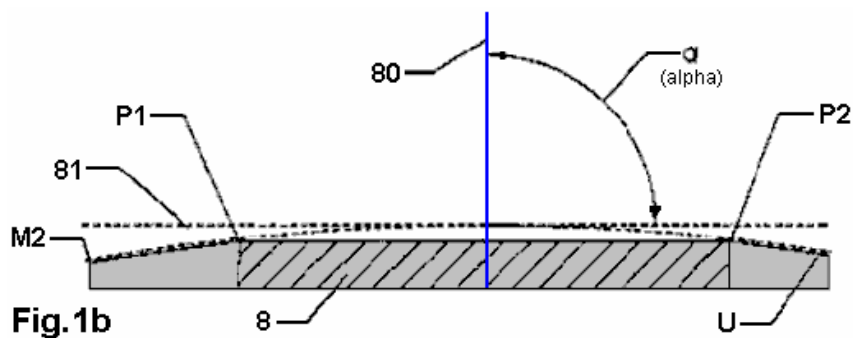

Fig.1b

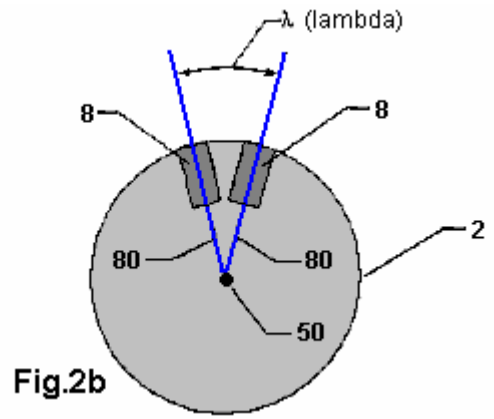
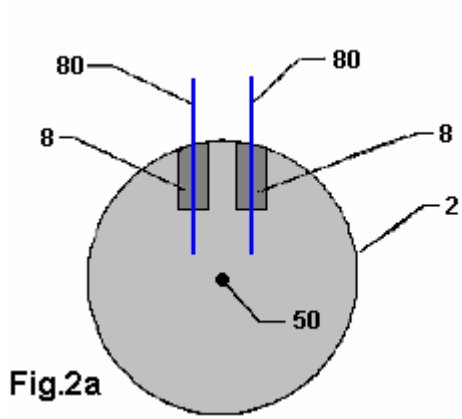

Fig.2a is an oblique view of the inner stator without magnets and **Fig.2b** is a view of the inner stator at right angles to the shaft axis.

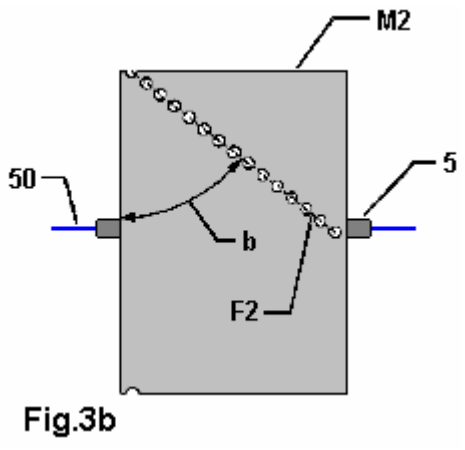
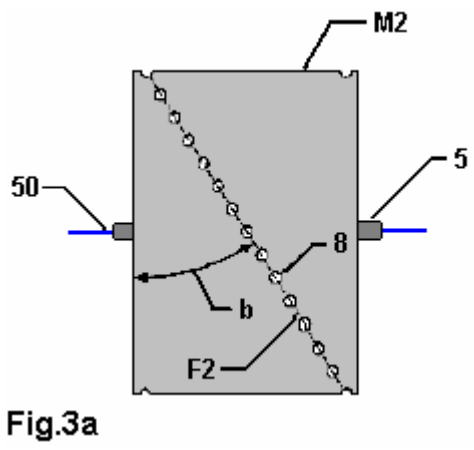

Fig.3 Shows a magnet arrangement for the inner stator

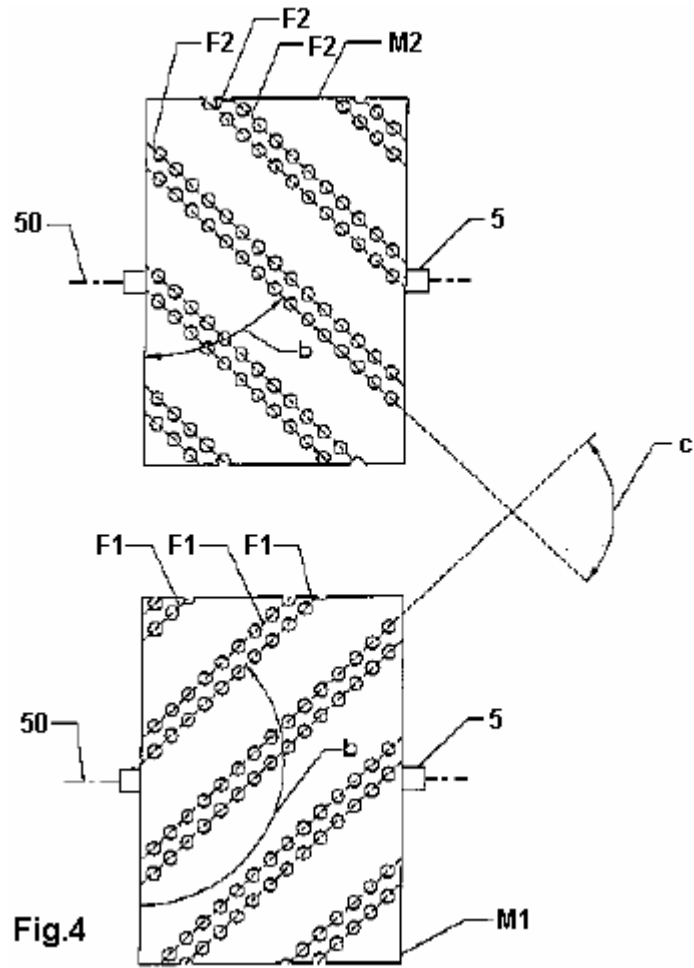

Fig.4 a section through the inner stator, along the line **A--A** indicated in **Fig.12b**

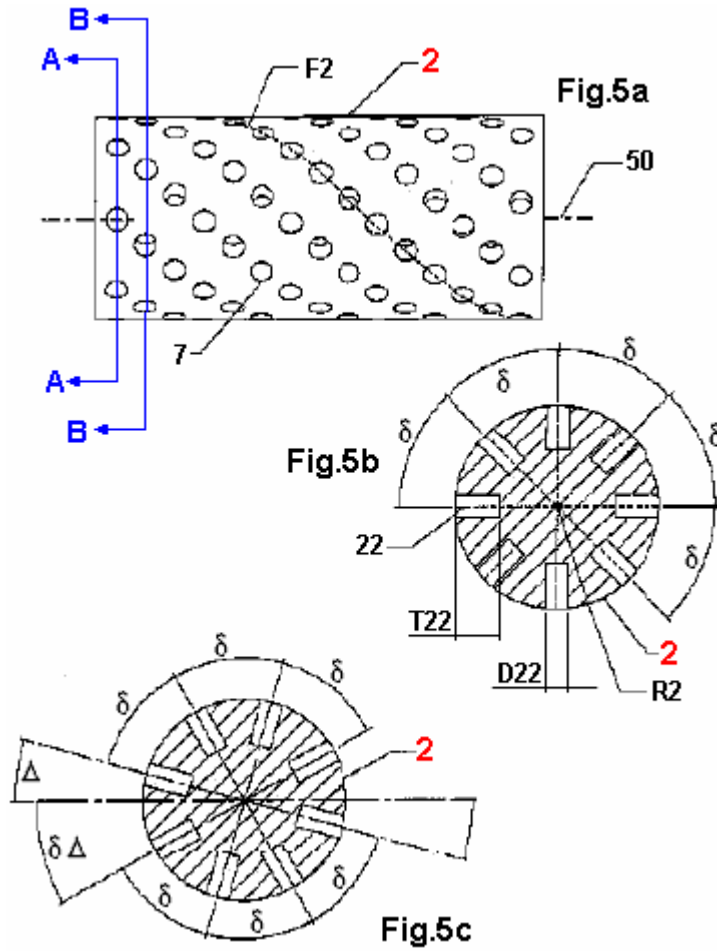
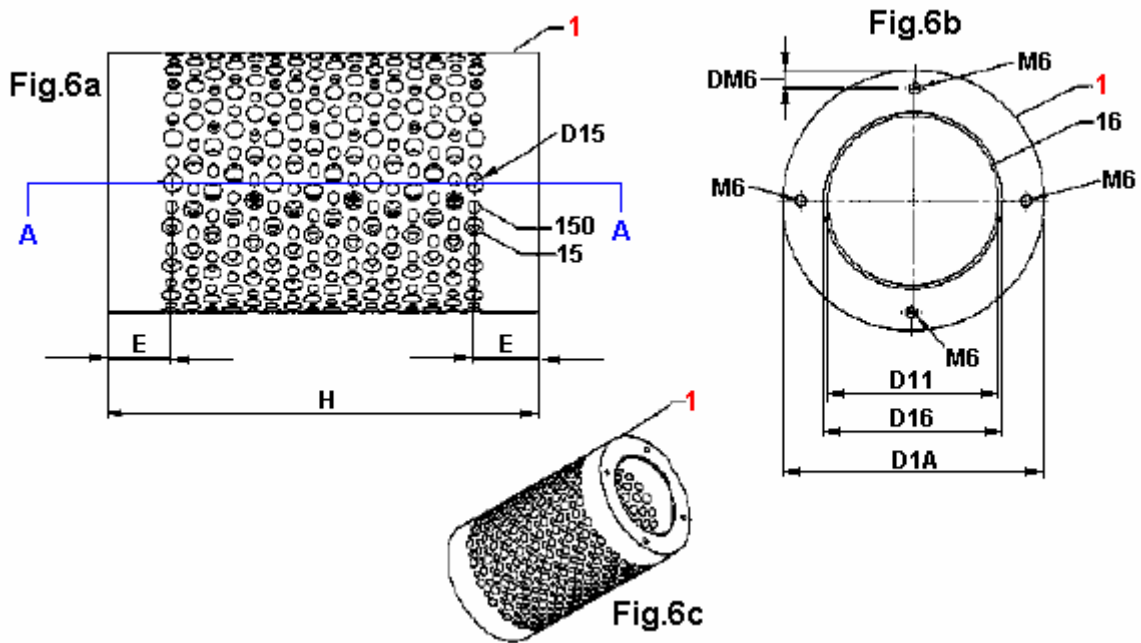

Fig.5a is a view of the fastening device perpendicular to the shaft axis and **Fig.5b** is a view of the fastening device in the direction of the shaft axis



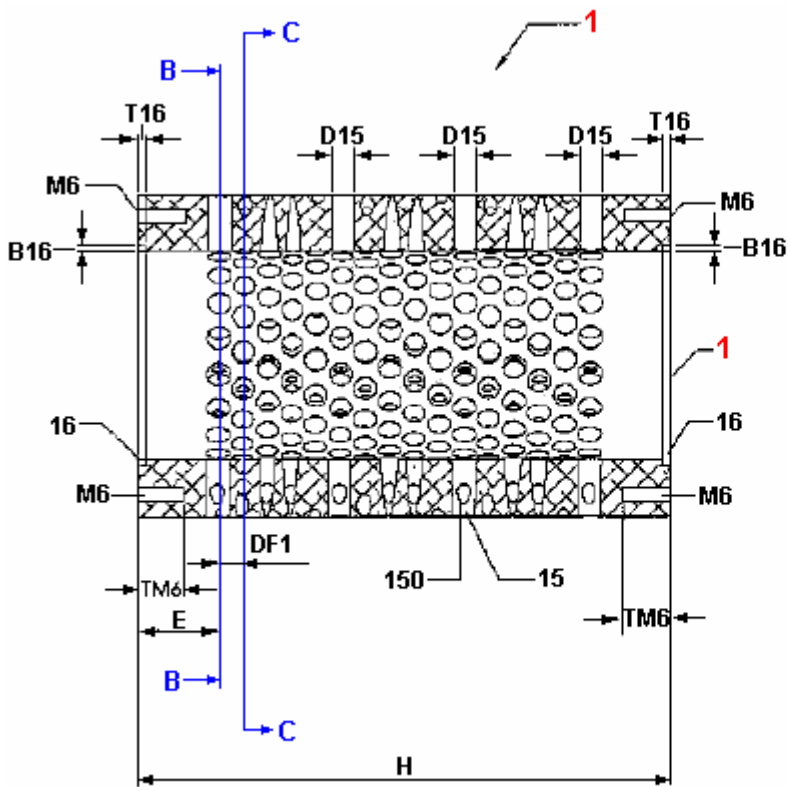

Fig.6d

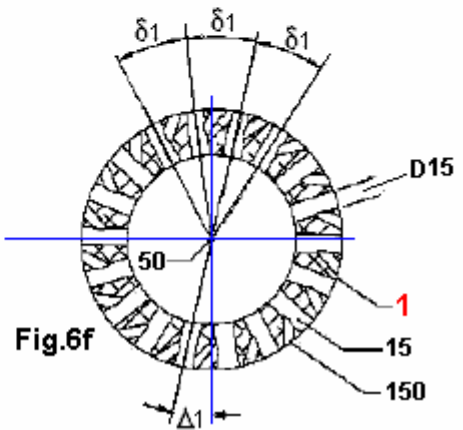
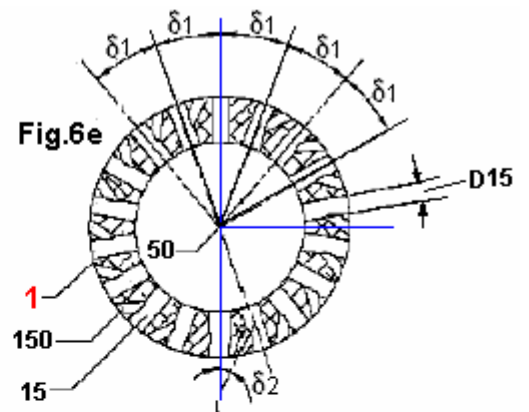

Fig.6 is a perspective view of the rotor

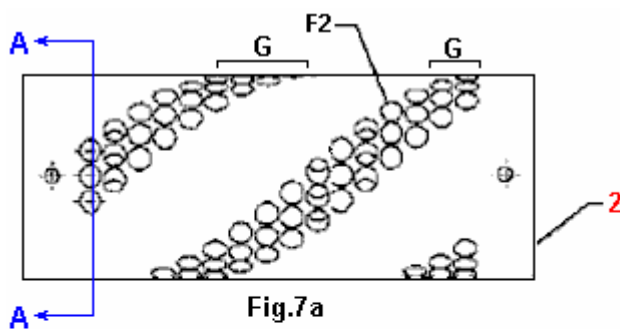

Fig.7a

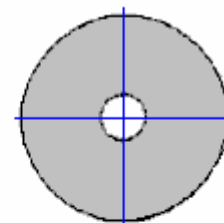

Fig.7b

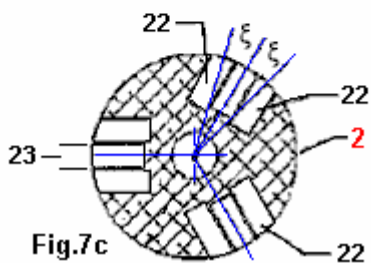

Fig.7c

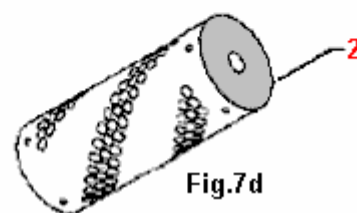

Fig.7d

Fig.7a is a schematic view of the inner stator and rotor. Fig.7b is a diagram of possible angle of the magnetic axis of the magnets in the rotor;

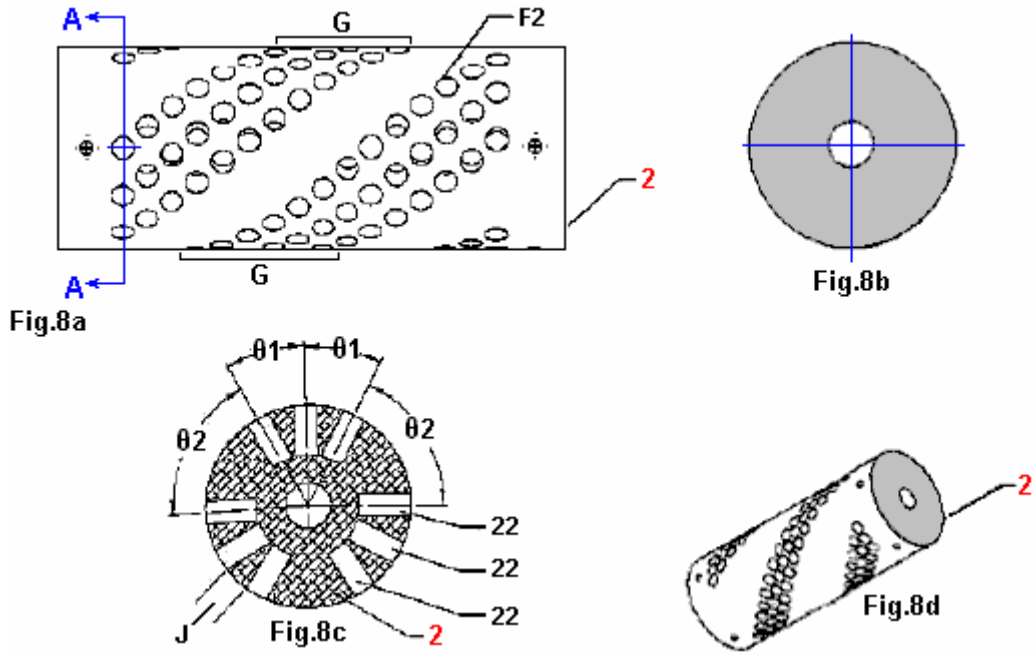

Fig.8a shows the magnetic arrangement of the rotor, along the direction X--Y indicated in **Fig.16**. **Fig.8b** is a detailed view of the rotor shown in **Fig.8a**.

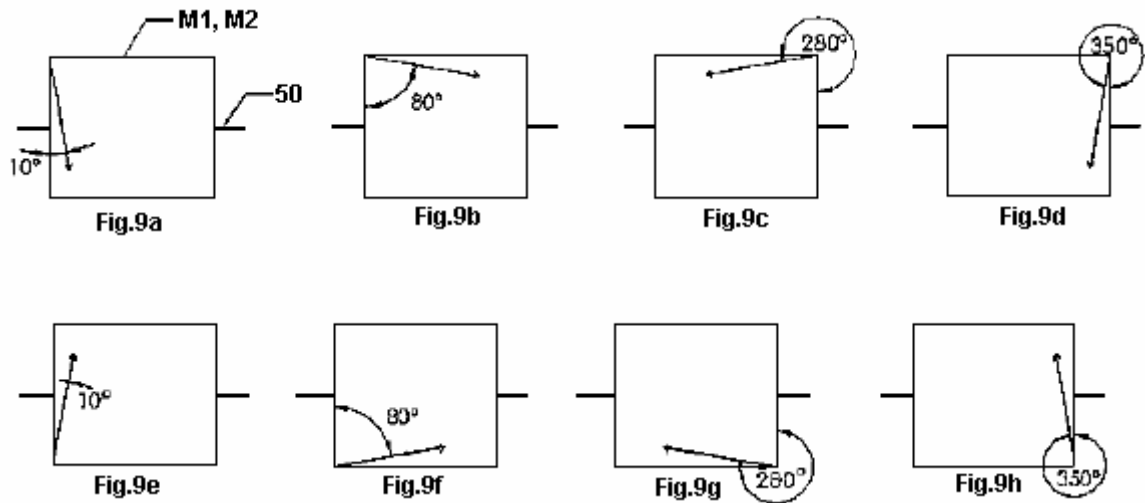

Fig.9a to 9h show the angles of sets of magnets installed in the rotor when viewed from the side. These are shown in greater detail later in this description.

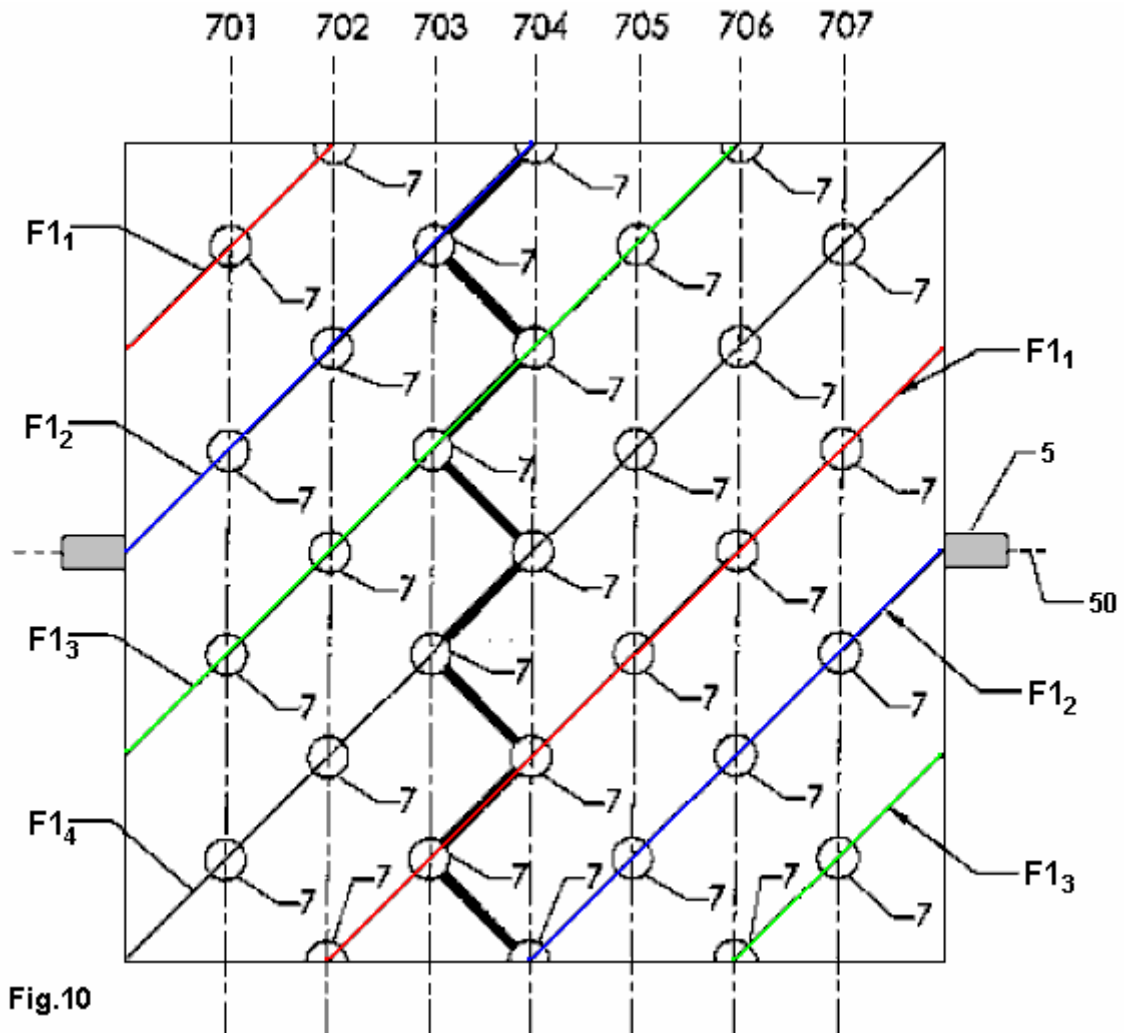

Fig.10

Fig.10 shows the positions of magnet strings embedded in the rotor. These are given in more detail later on.

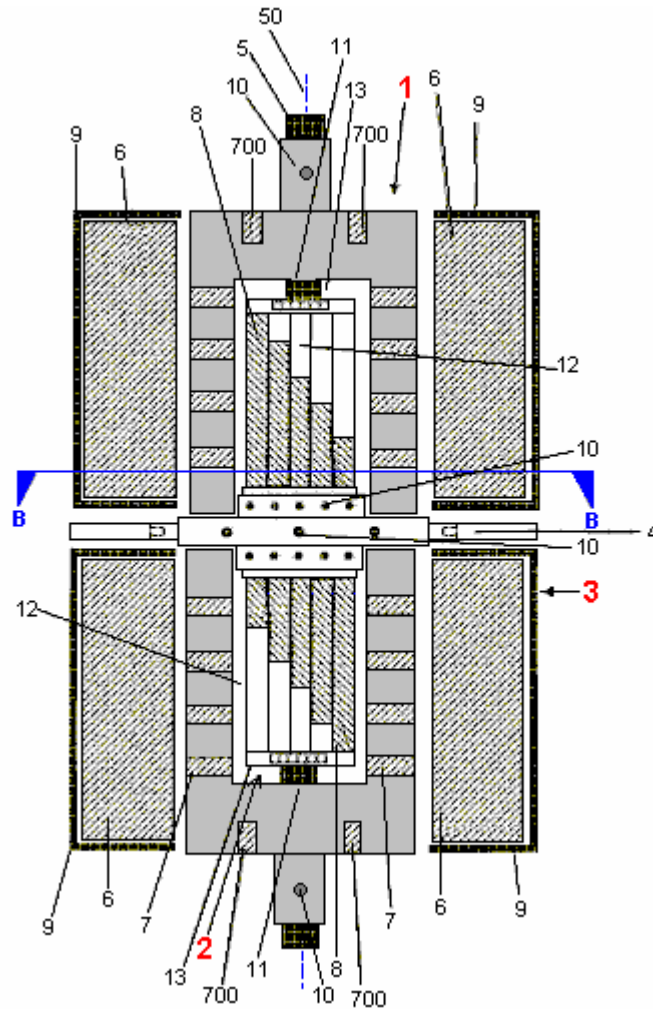

Fig.11 shows the arrangement of magnets on both stators and the rotor, shown as a section along the shaft axis.

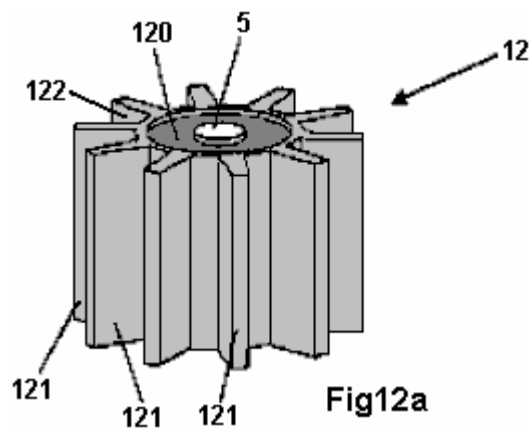

Fig.12a shows the arrangement of cylinder and fins on the rotor before the rotor magnets are installed in the spaces between the fins.

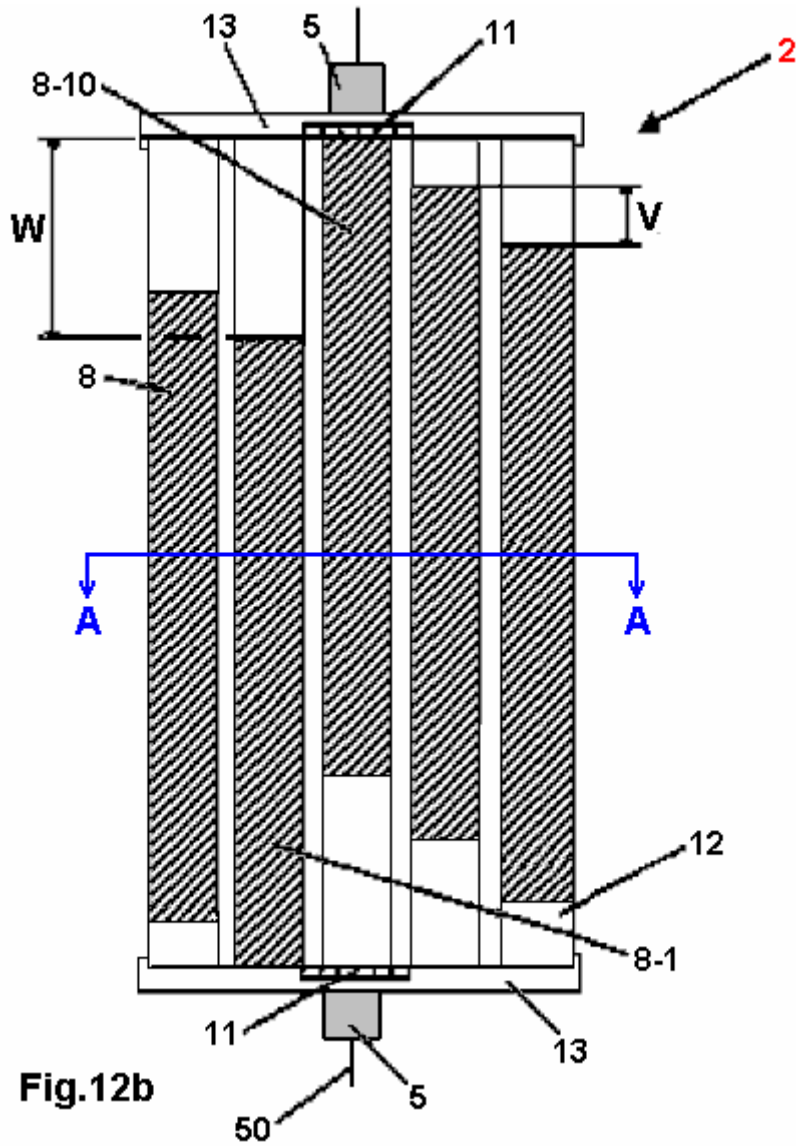

Fig.12b shows the arrangement of the magnets of the rotor, as seen in a view at right angles to the longitudinal axis of the rotor.

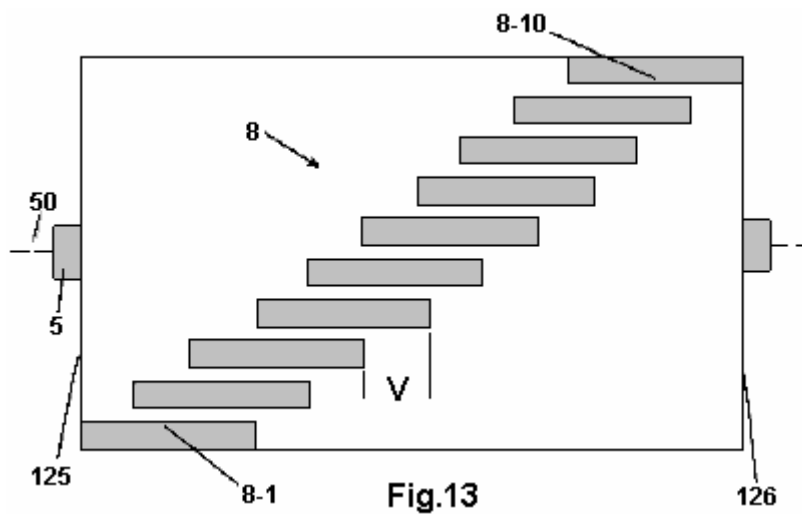

Fig.13 shows the stepped positioning of the magnets of the rotor. This view shows the surface of the rotor and its shaft, opened out and laid flat. That is, the rectangle shown here is actually the whole of the cylindrical

surface of the rotor. In this view, the fins between the magnets are not shown in order to emphasise the stepping of the magnets relative to each other.

DETAILED DESCRIPTION

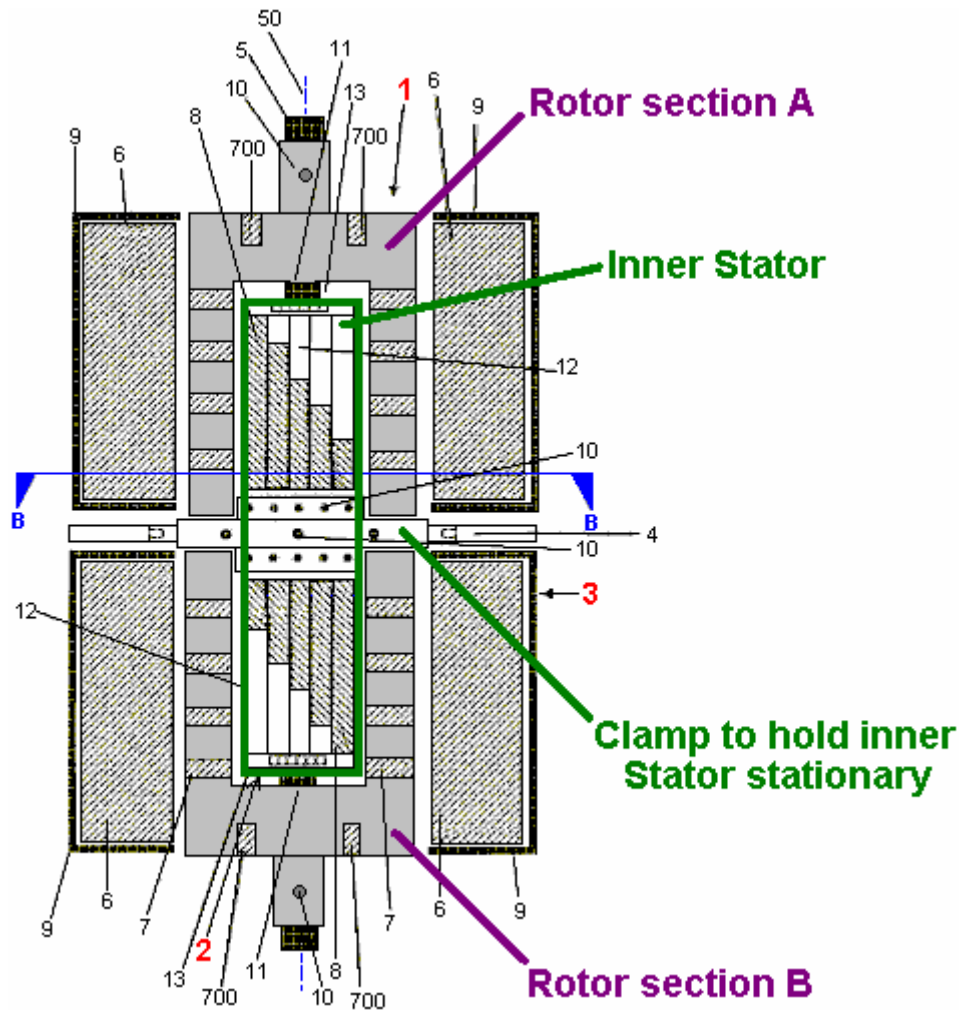

Fig.1 shows a schematic representation of the device having an inner stator **2**, a rotor **1** and an outer stator **3**, which are arranged coaxially around the shaft axis **50** of a pivoting rod-shaped shaft **5**. The cylindrical inner stator **2** has at each end, an end cap **13** which is in the form of a circular disc with a ball-race bearing **11** mounted on it. The bearing **11**, maintains the position of the inner stator **2** relative to shaft **5**. The drive shaft **5** is normally made from a non-magnetic material such as plastic, (not steel) and typically, has a diameter of 10 mm to 40 mm and a length of 100 mm to 400 mm.

The inner stator **2** has a core **12** with magnets **8** mounted on its outer surface. The inner stator **2** is held stationary by a mounting device **4**, which is secured in position in a mechanical housing (not shown), and is held firmly fixed in this way.

The rotor **1** consists of two mirror-image rotor drums, each with a pipe section and a circular disc section which is clamped rigidly to drive shaft **5** by means of grub screws **10**. Each of the rotor drums has magnets **7** mounted on it. These magnets **7**, are positioned in five distinct places and they have one magnetic pole facing towards the shaft and the other pole facing radially outwards.

The rotor drums are positioned so that there is a cylindrical air gap between them and the inner stator **2**. This air gap is usually of the order of 3mm to 50 mm. Although the two halves of the rotor are separated by the clamping mechanism **4** which prevents the inner stator from rotating, the rotor halves are positioned so that the magnets within them are balanced and so there is no irregular force generated when shaft **5** is spun at high speed. At the ends of the rotor drums there are magnets **700** as the objective of this design is to have the rotor suspended magnetically.

The outer stator **3** is composed of two separate half cylinders **9**. Each of these cylinders **9**, contains magnets **6** mounted on it's inner face. Although each section of the outer stator consists of a hollow cylinder, the outer ends of the stator housing form a complete disc which surrounds the drive shaft **5** and forming a complete enclosure rather than leaving the device open at the ends. There is an air gap between the faces of the magnets mounted on the inner surface of the cylindrical frame **9** and the faces of the magnets mounted on the rotor. These sets of magnets face each other and the air gap between them is also typically 3 mm to 50 mm. The magnets on each of the stators are parallel to the shaft axis **50**. The outer stators is constructed so that it can be moved relative to the inner stator, thus altering their magnetic overlap. This alteration can be made by moving the outer stator when the motor is actually running.

The magnets designated **6**, **7**, and **8**, are dipole magnets and in a preferred embodiment, these are permanent magnets, for example, consisting of SmCo (samarian cobalt) and/or NdFeB (neodymium/iron/boron). It is also possible for one or more of these magnets to be an electromagnet. The magnetic flux density of the magnets **6**, **7**, and **8** is preferably in a range from 0.4 to 1.4 Tesla.

The frame is preferably made from a non-magnetic material such as aluminium with a wall thickness from 2 mm to 10 mm.

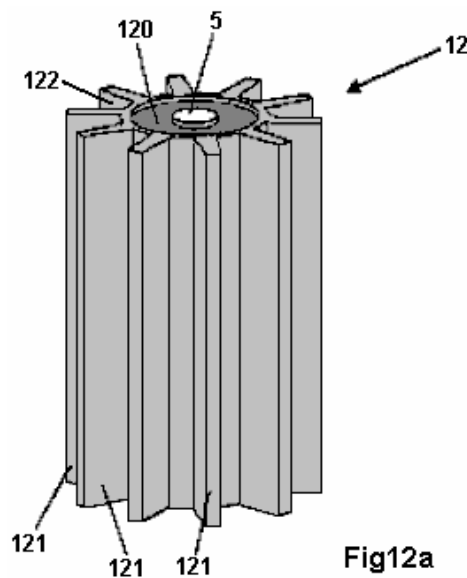

Fig.12a shows an inner stator frame made from a non-magnetic material (such as aluminium or copper). The frame **12** has a circular cylinder **120** which has attached to it's outer surface, radial ribs **121**. Each of these ribs extends along the central axis of the cylinder **120** along the full length of the cylinder, that is, from its' base to the top surface. The ribs are distributed uniformly over the cylinder circumference, forming grooves **122**. Cylinder **120** has a central hole along it's axis for shaft **5** to run through. Both of the end surfaces of cylinder **120** are recessed to accommodate one of the ball bearings **11**. The diameter of the stator core **12** is typically 50 mm to 500 mm with a length of 100 mm to 300 mm. The width of the ribs **121** is generally not more than 100 mm and is usually about 20% of the length of the ribs **121**.

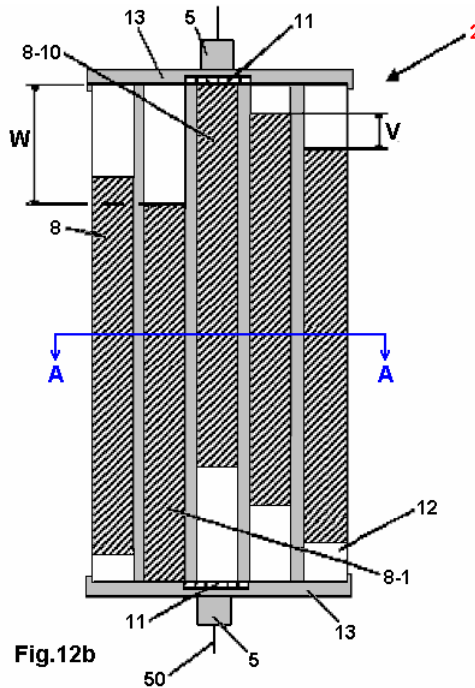

Fig.12b shows a schematic representation of the inner stator **2**. The inner stator **2** is composed of the inner stator frame **12**, the magnets **8** and the end caps **13**. The magnets **8** are of equal length but their length is less than the length of the stator core **12**. These magnets form the outer surface of the stator. They are seated in the grooves **122** and held in position by the ribs **121**. The first magnet **8-1** is inserted flush with the end cap **13**. The other magnets **8** each have an axial offset **V** along the shaft axis **50** arranged so that there is an even stepping of the magnets with the final magnet **8-10** butting up against the second end plate **13**. The axial offset **V** is the total overall gap **W** divided by $(n - 1)$, where n is the number of magnets and so, **V** varies with the number of magnets used. In a typical arrangement, **V** is 5% of the length of the magnets **8**.

The end caps **13** have a diameter of 50 mm to 500 mm and a thickness of 5 mm to 20 mm. A typical length for the magnets **8** is 100 mm. The magnet dimensions are arranged so that when they are positioned in the grooves **122**, the inner stator **2** has a substantially uniform outer surface.

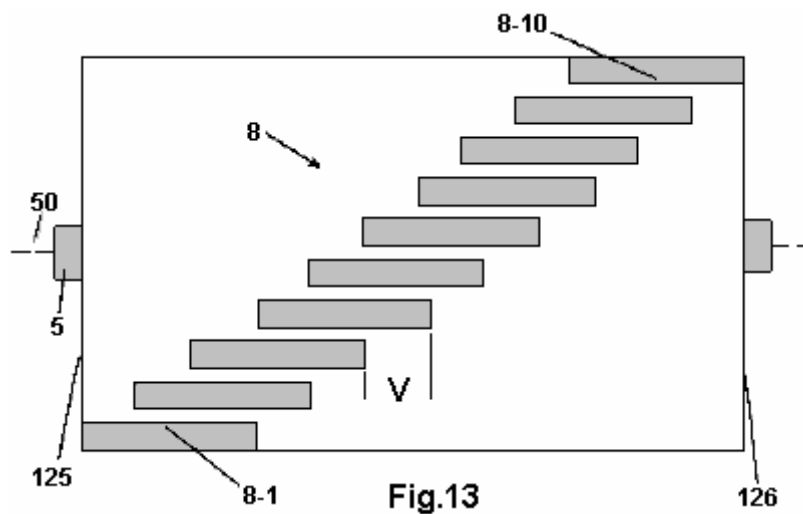

Fig.13 shows an opened-out view of the outer surface of the inner stator **2**. Here, ten magnets **8** are arranged with even spacing. The under side of the magnets taper in the direction of the shaft axis **50** and so they have a lesser width near the centre of the stator than they do at the outside surface. The first magnet **8-1** is positioned

with its end face aligned with the base **125** of the inner stator core **12**. The remaining nine magnets (8-2 to 8-10) are each offset by the amount **V** with the last magnet **8-10** reaching the top surface of the inner stator core **126**.

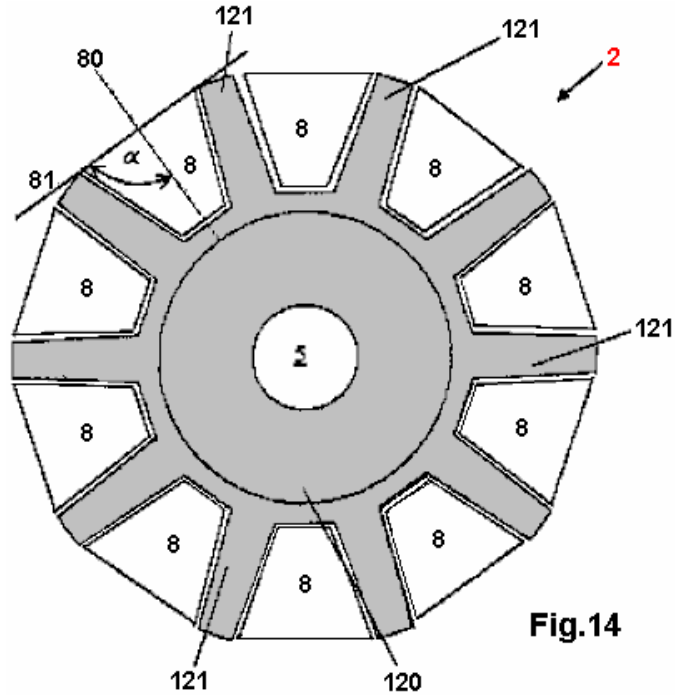

Fig.14

Fig.14 shows a cross-section through the inner stator **2** along the plane **A--A** of **Fig.12b**. The inner stator **2** has a hollow cylinder **120**, through which the central axis of the shaft **5** passes. Running along the outer surface of the cylinder are the ribs **121**. The hollow cylinder **120** typically has a diameter of 100 mm and a length of 170 mm. In the gaps formed between the ribs **121** the magnets **8** are placed. When seen in the plane **A--A** these magnets have a trapezoidal cross-section. These magnets have two magnetic poles and the magnets are positioned so that the magnetic axis **80** which runs through the two poles is radial within the section plane **A--A**. An angle α [alpha] formed at the intersection of the magnetic dipole axis **80** of a magnet **8** and the tangent **81** to the ribs **121** can have a value between 14 degrees and 90 degrees. In the case shown in **Fig.14** the angle alpha is 90 degrees.

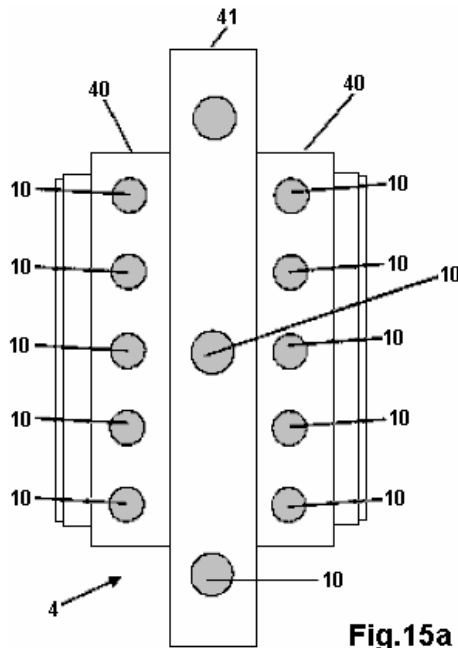

Fig.15a

Fig.15a shows the fastening device **4** in a view perpendicular to the shaft axis **50**. The fastening device **4** has an inner hollow cylinder **40** with a smaller radius and an outer fixing ring plate **41** with larger radius. The inner hollow cylinder **40** and the outer ring fastening plate **41** are connected together. The hollow cylinder **40** is used for receiving and fixing the inner stator **2** by means of screws **10**. The fastening ring **41** is part of a mechanical housing (not shown) for holding the device firmly positioned.

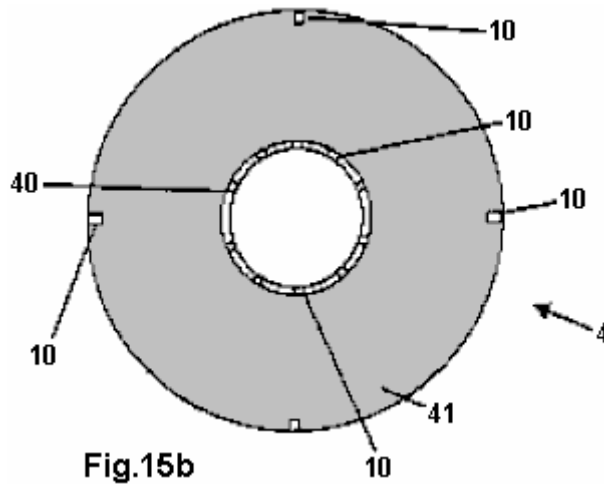

Fig.15b shows the fastening device **4** in a view in the direction of the shaft axis **50**. The mounting ring plate **41** has at its periphery, four screws **10** for attachment to the mechanical housing of the hollow cylinder **40** which has on its circumference, a number of screws **10** for fixing the inner stator in place.

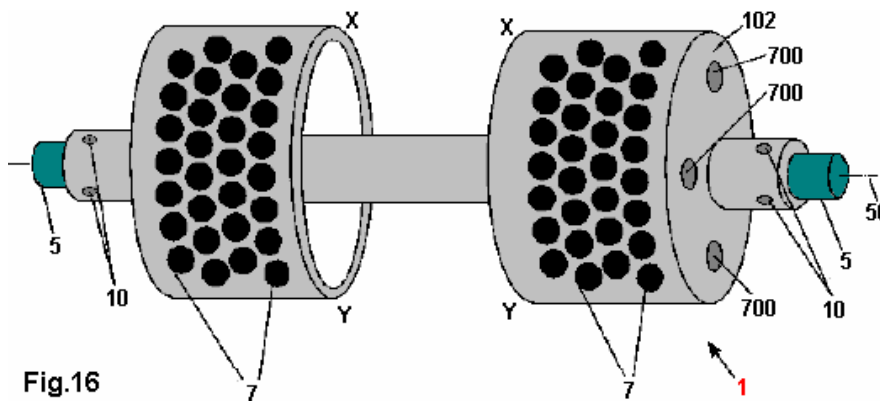

Fig.16 is a view of the rotor **1**, which is clamped to shaft **5** by means of the screws **10**. The rotor **1** consists of two separate drums attached to a central hollow shaft. Mounted in its outer surface are a series of magnets **7** sunk into circular holes. The rotor itself is constructed using a non-magnetic material such as aluminium or copper. The distance between the two rotor drums is 15 mm and they have an outer diameter of 165 mm, a height of 70 mm and a wall thickness of 26 mm. Each rotor drum has a top surface annular disk **102**, into which two or more magnets **700** are sunk. These are positioned uniformly around the circumference of the disc as shown in the diagram. The magnetic dipole axis of magnets **700** is parallel to the shaft axis **50**.

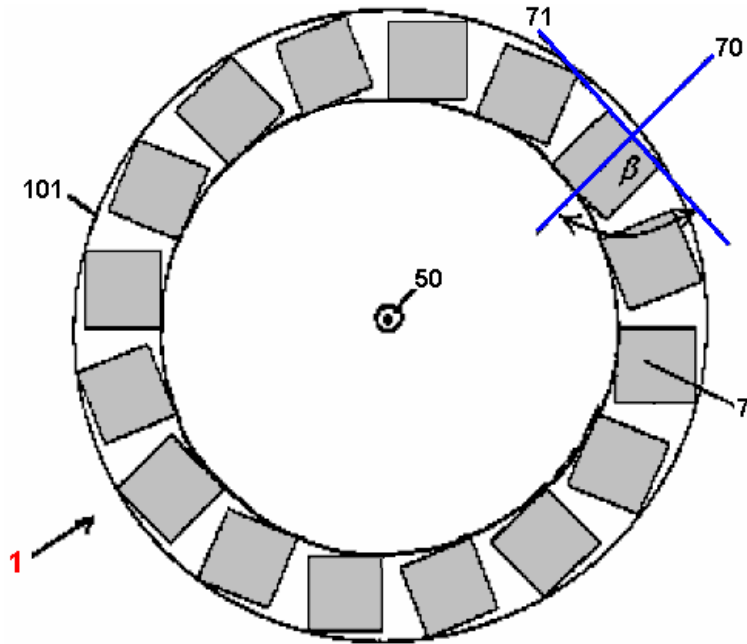

Fig.17a is a schematic representation of the possible orientations of the rotor magnets **7** when seen as viewed looking parallel to the shaft axis **50**. The magnetic dipole axis **70** of rotor magnets seven is in a plane which is radial to the shaft axis **50**. The angle β [beta] between the magnetic dipole axis **70** and the tangent **71** breaks through the outer periphery of the hollow cylinder **101** of the rotor **1** and this angle can have values between 14 degrees and 90 degrees.

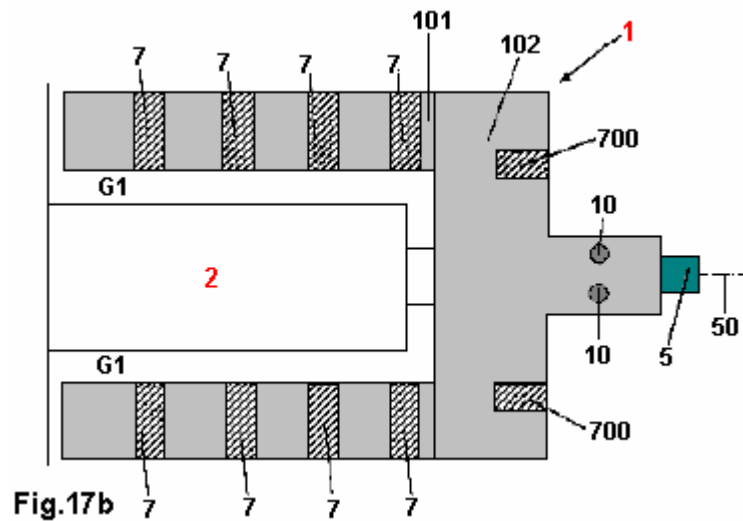

Fig.17b

Fig17b is a schematic view of one rotor drum and part of the inner stator **2**, where the view is perpendicular to the shaft axis **50**. The rotor **1** is clamped to the shaft **5** by the screws **10** and held rigidly in position. The shaft **5** passes through a ball bearing inset into the inner stator **2** and so can rotate freely relative to the inner stator. The rotor has two drum, or bell-shaped, sections which surround the inner stator. The rotor **1** has a hollow cylindrical section **101**, which extends away from the top surface **102**. Since the inner stator is fixed and prevented from rotation by it's anchoring device (component **4** in **Fig.1**), the rotor spins the hollow cylinder **101** around it. The hollow cylinder **101** of rotor **1** is separated from the inner stator **2** by an annular air gap **G1**. The hollow cylinder **101** of rotor **1** has magnets **7** sunk into holes in it. The top surface **102** of the rotor **1** also has holes in it and these are used to install the magnets **700** in it.

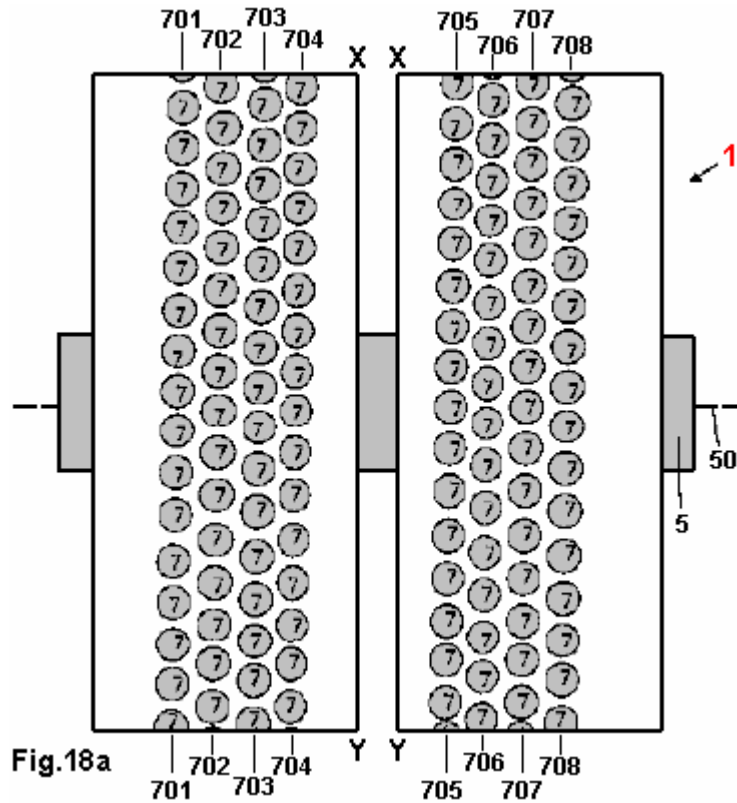

Fig.18a shows the outer surfaces of the two halves of the rotor drum **1** laid out flat instead of curved into a circle in the **X--Y** plane shown in **Fig.16**. This surface is perpendicular to the shaft axis **50** and rows of magnets **7** are positioned in rows **701 to 708**. Each of these rows is slightly offset in relation to the row beside it, resulting in a zig-zag layout of the magnets **7**.

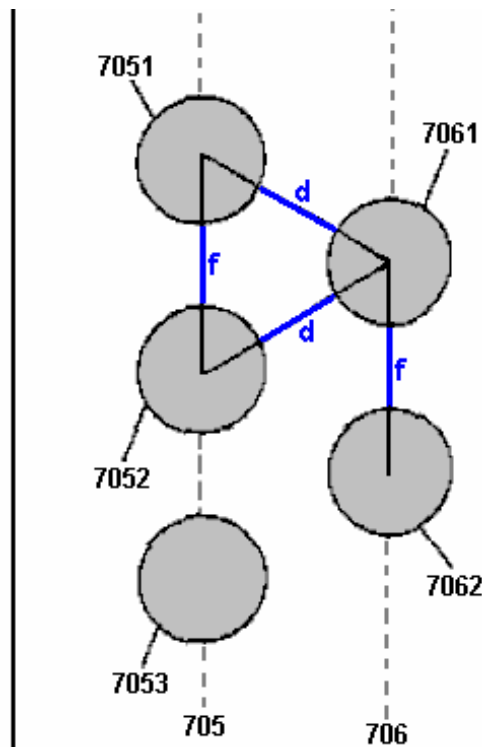

Fig.18b shows, in enlarged detail, the positioning of the magnets **7** shown in **Fig.18a**. The centres of the magnets **7** in the rows **705** and **706** have a constant separation **f** between their edges. The distance between any two adjacent rows, say, **705** and **706**, is chosen so that the arrangement is as shown in **Fig.18b** with constant magnetic separation of length **d** between the edges of the magnets in adjacent rows. For example, the magnets **7051** and **7052** are exactly the same distance apart as magnets **7061** and **7062** the adjacent row **706**. Also, the centres of the three magnets **7051**, **7052** and **7061** form an isosceles triangle. This relationship holds for all of the

magnets in all seven series **701** to **708**. Although the magnets **7** are shown in the diagrams as being circular, they could well be other shapes such as square or hexagonal.

The length **d** ranges from about 3 mm to 50 mm. A distance which is particularly preferred, is 5 mm. The distance **f** ranges from about 10 mm to 70 mm.

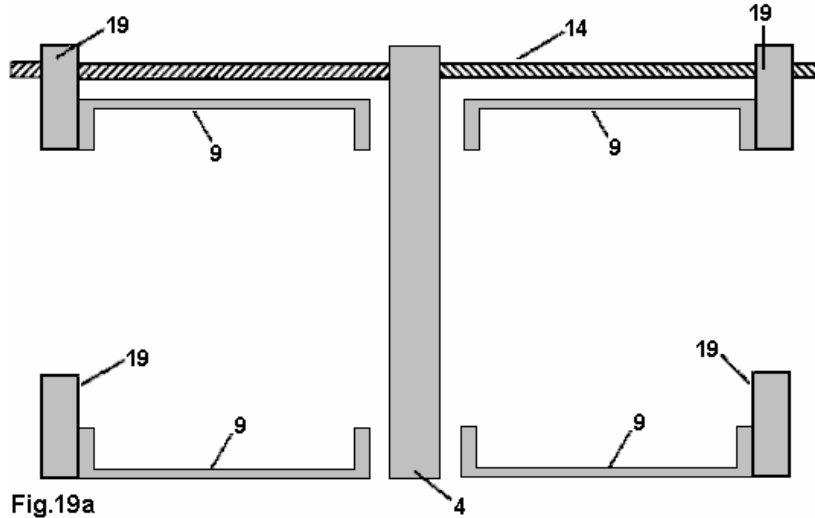

Fig.19a shows a longitudinal section through the mechanical housing for the device, i.e. a section parallel to the shaft axis **50**. The mechanical housing includes the support piece **4** for clamping the inner stator **2** to prevent it from rotating, the mount **19** for guiding the movable halves of the outer stator **3**, and a rotating threaded rod **14** which can move both halves of the outer stator **3** relative to the rotor and/or the inner stator **2**. The gear shaft **14** has two threaded sections with threads which run in opposite directions (right-hand and left-hand threads). The rotation of this shaft causes the two halves of the outer stator housing to move in a symmetrical manner in opposite directions, inwards or outwards. The guide devices **19** are mounted on the gear shaft **14** and so they only move in one plane. The outer cylindrical sections **9** which house the outer stator **3** are firmly attached to the end caps **19**. Typically, this mechanical housing has a height of 400 to 600 mm, a width of 400 mm and a depth of 530 mm.

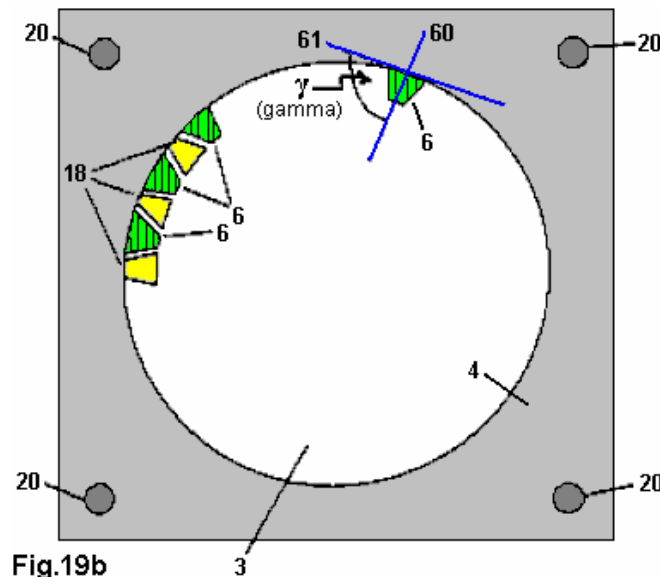

Fig.19b is a section through the outer stator **3**, the section plane is perpendicular to the shaft axis **50**. The outer stator **3** has arranged in it, a ring of non-magnetic fasteners **18**, between which magnets **6** are secured. For reasons of clarity, only some of the magnets **6** are shown although these magnets are mounted on the entire circumference of the outer stator **3**. The size of the magnets **6** and the non-magnetic fasteners **18** is chosen so that they form a hollow cylinder whose central axis is in the direction of the shaft axis **50**. The magnetic dipole axis **60** of the magnets **6** are perpendicular to the shaft axis **50**. An angle γ [gamma] between the magnetic dipole axis **60** and a tangent **61** to the outer periphery of the hollow cylindrical outer stator **3** is between 14 degrees and 90 degrees. The outer stator **3** is connected to the mounting block **4**, which includes the mounting columns **20**.

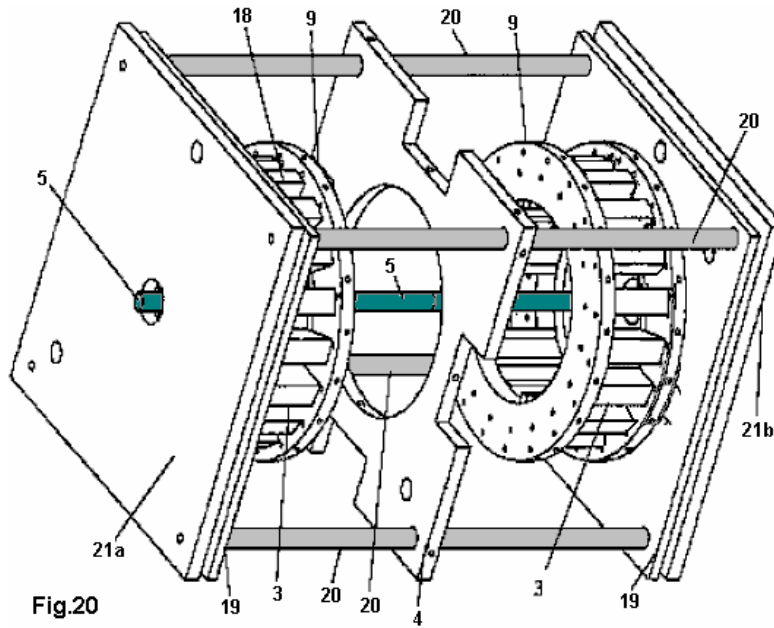
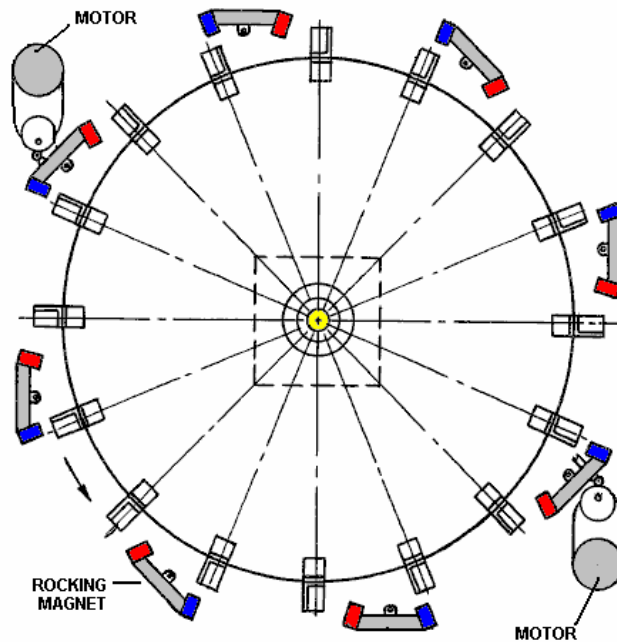

Fig.20 is a perspective view of the mechanical housing for the device. Additional practical details are available in the patent.

Donald Kelly's Permanent Magnet Motor.

In 1979, Mr Kelly was granted a patent on a permanent magnet motor design. He comments that apart from it being very difficult to generate sufficient power to mechanically move the stator magnets slightly to achieve continuous rotation, the resulting rate of revolutions is very low. For those reasons, he has opted to move the stator magnets slightly using small DC motors. His design is included here as it is a concept which is relatively easy to understand. The overall idea is not unlike that of Stephen Kundel who rocks the stator magnets with a solenoid, as shown earlier in this chapter. The objective here is to use a small electrical current to generate a powerful rotation far greater than would be possible from the electrical current itself, and so, produce what is in effect, a power multiplication through the use of permanent magnets. A slightly reworded copy of his patent is shown in the Appendix.



The operation is a simple strategy. Eight sets of magnets are mounted on rocker arms. These have two main positions. In the first position, the rocker magnets attract the magnets mounted on the rotor. When the rotor moves because of this attraction and reaches a point where there is about to be a backward drag on the rotor, the position of the rocker arms is altered so that the first set of rocker magnets are moved out of the way to a position where they have little effect due to their increased distance from the rotor magnets. This rocker movement also

moves magnets of the opposite polarity which push the rotor magnets on their way. In this design, the attraction and the push are applied to different sets of magnets. If the attraction is on magnets 1, 3, 5, etc. then the push is on magnets 2,4,6, etc. But, in spite of this, the pull and push are applied to every rotor magnet as it passes. The power needed to operate the electric motors is minimal as the power of the motor is provided by the magnets. Instead of two tiny motors, it would be possible to operate the rocker arms using small solenoids and if the motor is used to power an electrical generator, then the design could be made self-powered by using some of the electrical output to provide the necessary input power. The sketch above shows just one layer of the motor, but there can be as many layers as you like, each driving the single output shaft, and increasing it's power with every layer.

Mike Brady's "Perendev" Magnet Motor.

One of the most widely known permanent magnet motors is the "Perendev" motor, which catches the imagination of most people. It is said that dozens of these motors have been made and sold as motor/generators with an output of not less than 100 kilowatts. As far as I am aware, this has not been confirmed, nor have there been independent tests made on the motor other than a brief test by Sterling Allan. However, let me stress again that it is **very** difficult to get any permanent-magnet-only motor operating and it is much easier to start with one like the Adams motor shown in Chapter 2, or the Charles Flynn motor shown earlier in this chapter. Please notice as well, that the magnets used in this design are non-standard magnets and so will be difficult to get and probably very expensive because of that and specialised magnetic shielding is used.

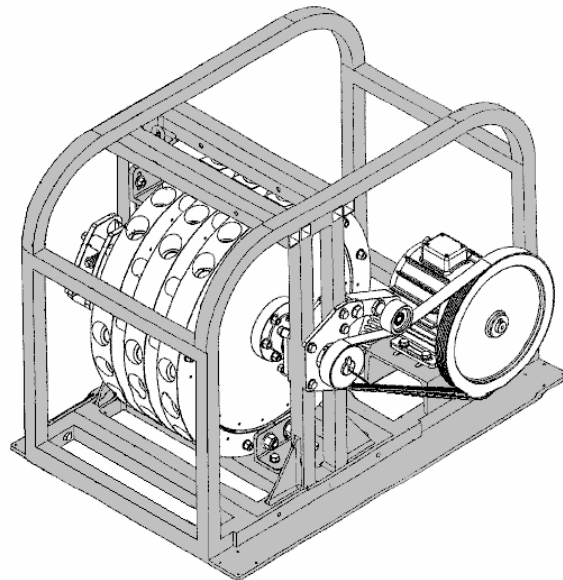

Mike's Patent Application WO 2006/045333 A1 dated 4th May 2006 is shown in the Appendix. In mid 2010, Mike had so much difficulty in getting his design into commercial production that his financial backers are most unhappy with the situation, and if Mike is having difficulty in replicating it (as did Howard Johnson with his magnet motor) then a newcomer to this field would be well advised to stick with magnet motors which use movement of the stator magnets, such as Don Kelly, Stephen Kundel and others, or magnet motors using mechanical or electrical shielding such as the Charles Flynn motor, the Robert Tracy motor, or the Jines motor.

Patrick Kelly

<http://www.free-energy-info.tuks.nl/>

Chapter 2: Moving Pulsed Systems

There are three categories of pulsed system and we will consider each in turn. These are drive-pulsed systems, energy-tapping pulsed systems and gravity free-energy pulsing systems. Here we will look at systems where an electrical pulse is used to cause the device to operate by creating a temporary magnetic field caused by electric current flowing through a coil or "electromagnet" as it is often called. Many of these systems are rather subtle in the way that they operate. One very well-known example of this is

The Motor/Generator of Robert Adams.

The late Robert Adams, an electrical engineer of New Zealand designed and built several varieties of electric motor using permanent magnets on the rotor and pulsed electromagnets on the frame of the motor (called the "stator" because it does not move). He found that if they were configured correctly, then the output from his motors exceeded their input power by a large margin (800%).



The diagram of his motor intended to show the basic operating principle is shown here:

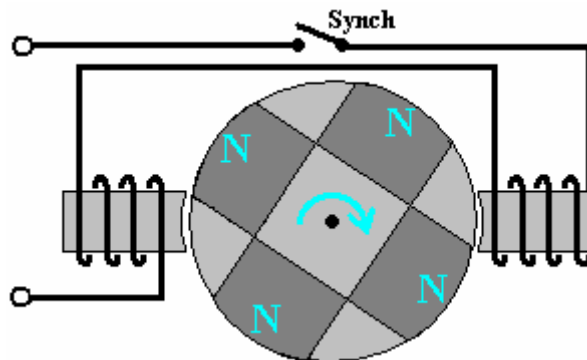

If a motor is built like this, then it will most certainly work but it will never reach 100% efficiency let alone exceeding the 100% mark. It is only with a specific configuration which is hardly ever publicised that high performance figures can be achieved. While Robert has shown several different configurations, in order to avoid confusion I will describe and explain just one of them. I am indebted to several of Robert's friends and colleagues for the following information and I should like to express my thanks to them for their help and support in bringing you this information.

First and foremost, high performance can only be achieved with the clever use of power collection coils. These coils need to be positioned accurately and their power collection restricted to just a very short arc of operation by connecting them to, and disconnecting them from, the output circuit at just the right instant so that the back EMF generated when the current draw stops, actually contributes to the drive of the rotor, speeding it on it's way and raising the overall efficiency of the motor/generator as a whole.

Next, the shape of the magnets used is important as the length to width proportion of the magnet alters the pattern of it's magnetic fields. In direct opposition to the diagram shown above, the magnets need to be much longer than their width (or in the case of cylindrical magnets, much longer than their diameter).

Further, a good deal of experimentation has shown that the size and shape of the electromagnets and pick-up coils has a major influence on the performance. The cross-sectional area of the core of the pick-up coils should be four times that of the cross-sectional area of the permanent magnets in the rotor. The reverse is true for the

cores of the drive coils as their cores should have a cross-sectional area of just one quarter of the rotor magnet cross-sectional area.

Another point which is almost never mentioned is the fact that big circuit gains will not be achieved unless the drive voltage is high. The minimum should be 48 volts but the higher the voltage, the greater the energy gain, so voltages in the 120 volts (rectified US mains voltage) to 230 volts (rectified mains voltage elsewhere) should be considered. Neodymium magnets are not recommended for drive voltages under 120 volts.

This is one of Robert's test circuits:

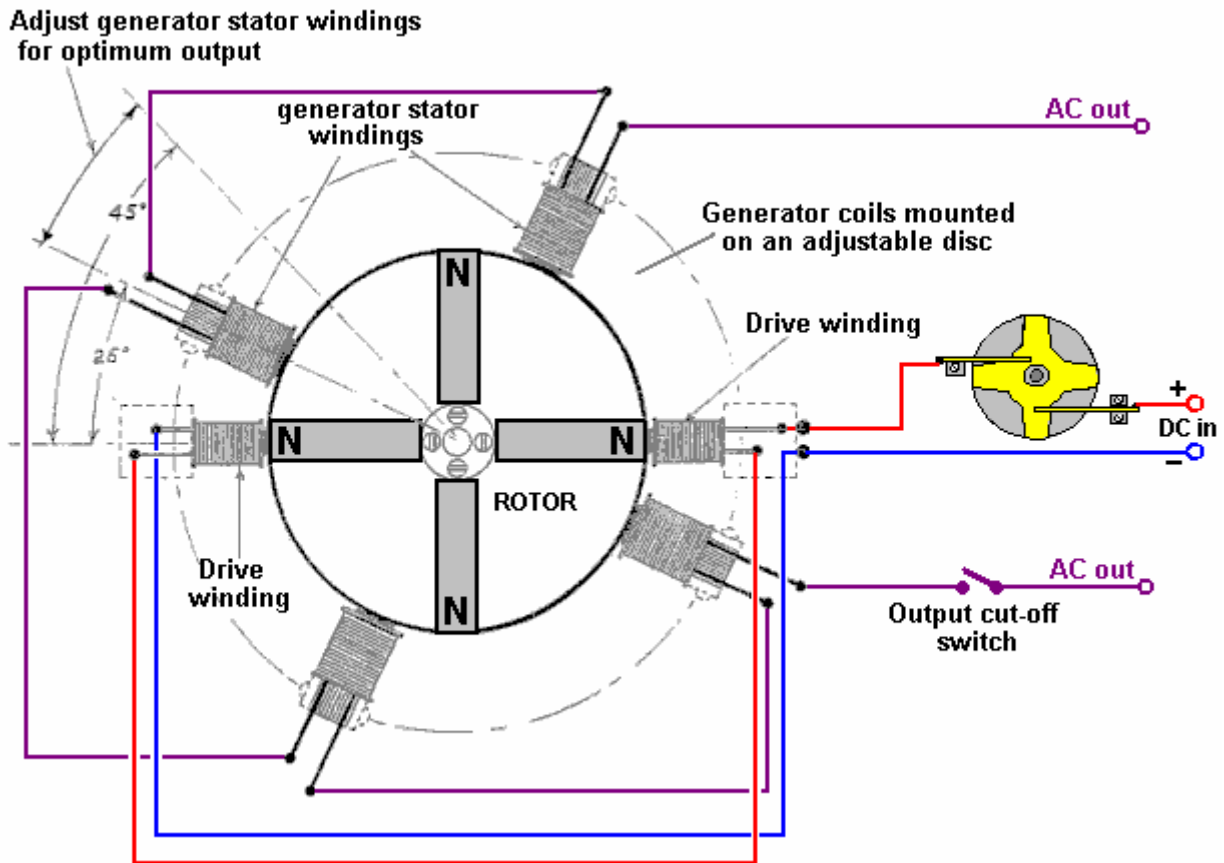

Notice that the cores of the "generator" pick-up coils are very much wider than the cores of the drive coils. Also notice the proportions of the magnets where the length is much greater than the width or diameter. The four generator windings are mounted on a single disc allowing them to be moved through an angle to find the optimum operating position before being locked in position and the two drive coils are mounted separately and held clear of the disc. Notice also that the power pick-up coils are much wider compared to their length than the drive coils are. This is a practical feature which is explained in greater detail later.

The DC input is shown passing through Robert's custom-made contactor switch which is mounted directly on the shaft of the motor/generator. This is a mechanical switch which allows an adjustable On / Off ratio, which is known as the "Mark/Space Ratio" or, if the "On" period is of particular interest, the "Duty Cycle". Robert Adams indicates that when the motor is running and has been adjusted to its optimum performance, then the Mark/Space ratio should be adjusted to minimise the On period and ideally get it down to about 25% so that for three quarters of the time, the input power is actually switched off. There are various ways of achieving this switching while still having a very sharp turn on and turn off of the power.

Robert considered mechanical switching of the drive current to be a very good option although he was not opposed to using the contact to power a transistor to do the actual switching and so reduce the current through the mechanical contacts by a major factor. His reasons for his preference for mechanical switching are that it gives very sharp switching, needs no electrical power to make it operate and it allows current to flow in both directions. The current flow in two directions is important because Robert produced various ways of getting the motor to feed current back into the driving battery, allowing it to drive the motor for long periods without lowering its voltage hardly at all. His preferred method of switching is shown here:

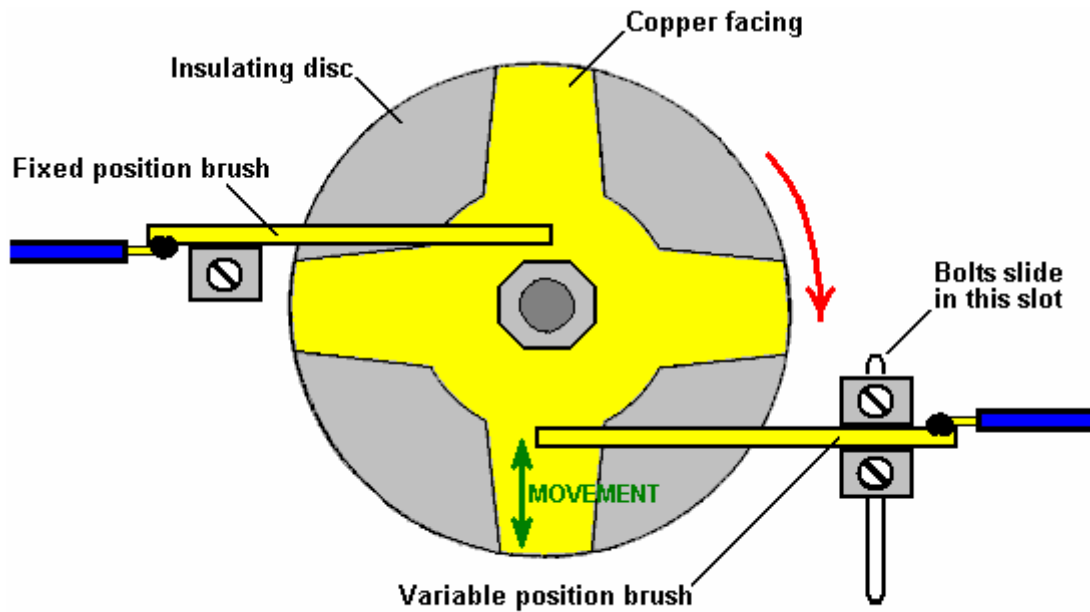

TIMING GEAR - TOP VIEW

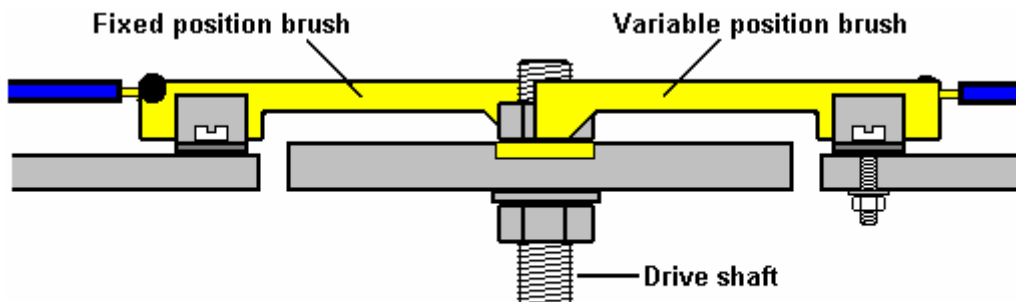

TIMING GEAR - SIDE VIEW

This switching gear operates as follows: The timing disk is bolted securely to the drive shaft of the motor and its position is set so that the electrical switch-on occurs when the rotor magnet is exactly aligned with the drive coil core. Adjustment of that timing is done by loosening the locking nut, rotating the disc very slightly and clamping the disc in position again. A spring washer is used to keep the assembly tight when the device is running. The disc has a star-shaped piece of copper sheet set into its surface and two silver-tipped, copper arm "brushes" slide across the surface of the copper star.

One of these two brushes is fixed in position and slides across the copper star near the drive shaft, making a permanent electrical connection to it. The second brush slides alternatively on the non-conducting surface of the disc and then over the conducting arm of the copper. The second brush is mounted so that its position can be adjusted and, because the copper arms taper, that alters the ratio of the "On" time to the "Off" time. The actual switching is achieved by current flowing through the first brush, through the copper arm and then through the second brush. The brush arms shown in the diagram above rely on the springiness of the copper arm to make a good brush-to-copper electrical connection. It might be preferred to use a rigid brush arm, pivot it and use a spring to ensure a very good contact between the brush and the copper star at all times.

The adjustment of the On to Off time, or "Mark/Space Ratio" or "Duty Cycle" as the technical people describe it, could perhaps do with some description. If the moveable brush is positioned near the centre of the disc, then, because of the tapering of the copper arms, the part of the non-conducting disc that it slides over is shorter and the part of the conducting copper arm with which it connects is longer, as the two sliding paths are about the same length, the current is on for about the same length as it is off, giving a Mark/Space ratio of about 50% as shown here:

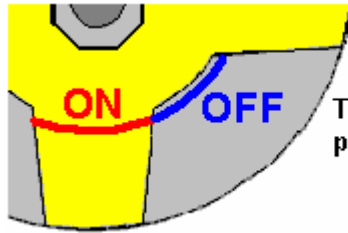

The On path is about the same length as the Off path and so the Mark/Space ratio is about 50%

If, instead, the moveable brush is positioned near the outside edge of the disc, then because of the tapering of the copper arm, the On path is shorter and the non-conducting Off path is very much longer, being about three times as long as the On path, giving a Mark/Space ratio of about 25%. As the moveable brush can be positioned anywhere between these two extremes, the Mark/Space ratio can be set to any value from 25% to 50%.

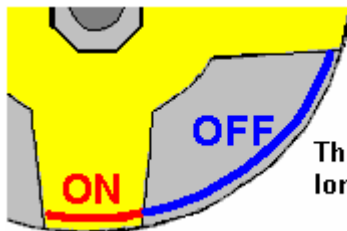

The On path is shorter and the Off path is much longer giving a Mark/Space ratio of about 25%

The two brushes can be on the same side of the drive shaft or on opposite sides as shown. One important feature is that the brushes touch in a position where the disc surface is always moving directly away from the brush mounting, causing any drag to be directly along the arm and giving no sideways loading on the brush. The diameter of the device is usually one inch (25 mm) or less.

You will also notice that the output is switched although the diagram does not give any indication of how or when that switching takes place. You will notice that the diagram has angles marked on it for the optimum positioning of the pick-up coils, well, an Adams Motor builder with a forum ID of "Maimariati" who achieved a Coefficient Of Performance of 1,223, found that the optimum switching for his motor is On at 42 degrees and Off at 44.7 degrees. That tiny 2.7 degree part of the rotor turn gives a substantial power output and cutting the output current off at that point causes the back EMF of the coils to give the rotor a substantial additional boost on its way. His input power is 27.6 watts and the output power is 33.78 kilowatts

Now for some practical details. It is suggested that a good length for the power pick-up coils can be determined by using the "paper clip test". This is done by taking one of the permanent magnets used in the rotor, and measuring the distance at which that magnet just begins to lift one end of a 32 mm (1.25 inch) paper clip off the table. The optimum length of each coil from end to end is exactly the same as the distance at which the paper clip starts to lift.

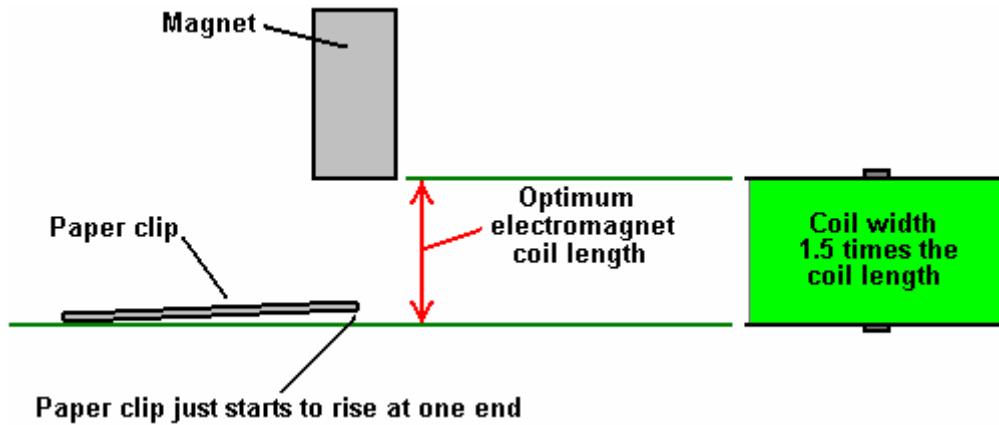

The core material used in the electromagnets can be of various different types including advanced materials and alloys such as 'Somalloy' or 'Metglas'. The power pick-up coil proportions are important as an electromagnet becomes less and less effective as its length increases, and eventually, the part furthest from the active end can actually be a hindrance to the effective operation. A good coil shape is one which you would not expect, with the coil width being, perhaps 50% greater than the coil length:

Contrary to what you would expect, the device draws in energy from the local environment better if the end of the pick-up coil farthest from the rotor is left unaffected by any other part of the device and the same applies to the magnet facing it. That is, the coil should have the rotor at one end and nothing at the other end, that is, no second rotor behind the coil. The speed at which the voltage is applied to, and removed from, the coils is very important. With very sharp voltage rises and falls, additional energy is drawn from the surrounding environmental energy field. If using transistor switching, then the IRF3205 FET has been found to be very good and a suitable driver for the FET is the MC34151.

If using a Hall-effect semiconductor to synchronise the timing, say the UGN3503U which is very reliable, then the life of the Hall-effect device is much improved if it is provided with a 470 ohm resistor between it and the positive supply line, and a similar 470 ohm resistor between it and the negative line. These resistors in series with the Hall-effect device effectively "float" it and protect it from supply-line spikes".

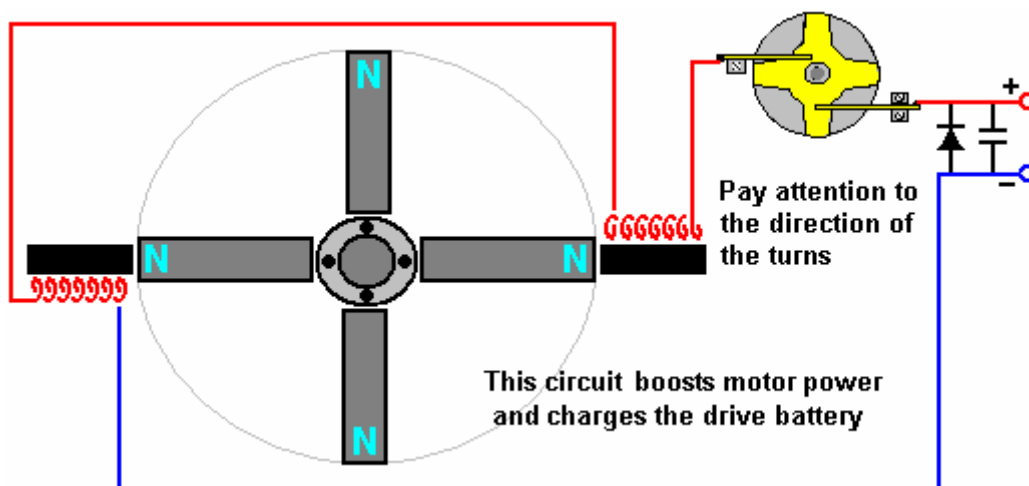

Here, two electromagnets are driven by the battery via Robert's 4-arm commutator which is mounted on the rotor shaft. Some of the recommendations given by Robert are the opposite of what you would expect. For example, he says that a single rotor construction tends to be more electrically efficient than one where several rotors are mounted on a single shaft. Robert is against the use of reed switches and he recommends making one of his commutators.

At one stage, Robert recommended the use of standard transformer shims for constructing the cores of the electromagnets. This has the advantage that matching bobbins for holding the coil windings are readily available and can still be used for pick-up coils. Later on, Robert swung towards the use of solid cores from the old PO Series 3000 telephone relays and eventually said that electromagnet cores should be solid iron.

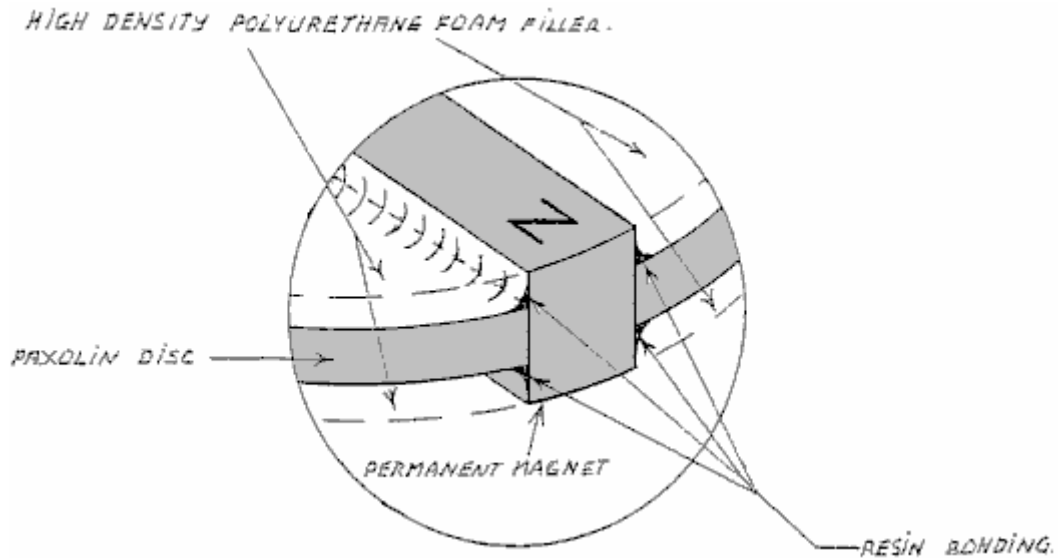

The diagrams presented by Robert show the magnets located on the rim of the rotor and pointing outwards. If this is done, then it is essential that the magnets in the rotor are firmly attached on at least five of their six faces and the possibility of using a ring of non magnetic material such as duct tape around the outside should be considered. That style of construction also lends itself to streamlining the rotor by having a completely solid construction, although it might be remarked that the motor would run better and more quietly if it were enclosed in a box which had the air pumped out of it. If that is done, then there will be no air resistance and because sound can't pass through a vacuum, quieter operation is bound to result.

While this may sound a bit complicated, there is no reason why it should be. All that is needed is two discs and one central disc which is the thickness of the magnets, with slots cut in it, the exact size of the magnets. The assembly starts with the lower disc, magnets and central disc. These are glued together, probably with epoxy resin, and that holds the magnets securely on four faces as shown here:

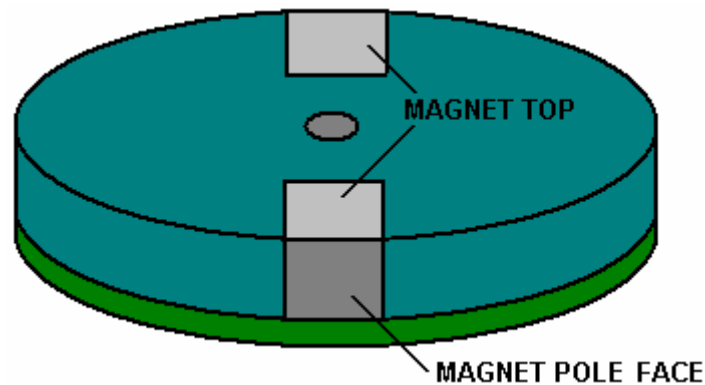

Here, the magnets are attached on the lower face, the right and left faces, and the unused pole face, and when the upper disc is attached, the upper faces are also secured and there is the minimum of air turbulence when the rotor spins:

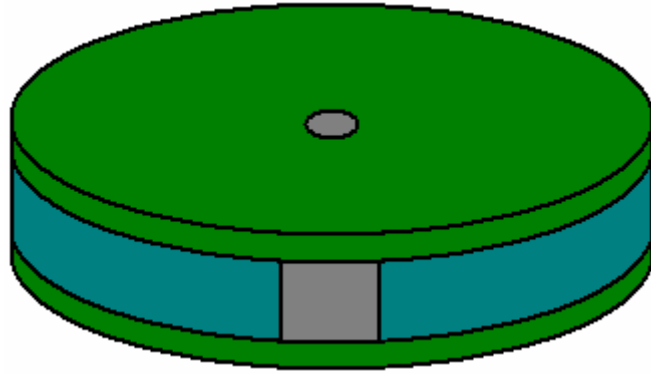

There is a "sweet spot" for the positioning of the power pick-up coils and it will usually be found that this is two or three millimetres away from the rotor. If that is the case, then there will be room for an outer band of duct tape on the rim of the rotor to provide additional protection against the failure of the magnet attachment method.

High-power versions of the motor/generator need to be enclosed in a metal box which is earthed as they are quite capable of generating a substantial amount of high frequency waves which can damage equipment such as oscilloscopes and create TV reception interference. There would probably be an improvement in performance as well as a reduction in sound if the box was airtight and had the air pumped out of it. If that is done, then there will be no air resistance as the rotor spins and since sound does not pass through a vacuum, quieter operation is possible.

Experienced rotor builders do not like the radial magnets style of construction because of the stresses on the magnet attachments if high rotational speeds are reached. It should not need to be said, but it is obviously a major requirement to keep your hands well away from the rotor when the motor is running as it is perfectly possible to be injured by the high-speed movement if you are careless. Please remember that this presentation must not be considered to be a recommendation that you build or use any device of this nature and it must be stressed that this text, in common with the entire contents of this eBook, is intended to be for information purposes only and no representations or warranties are implied by this presentation. Should you decide to construct, test or use any device, then you do so entirely at your own risk and no liability attaches to anybody else if you sustain any kind of injury or property damage as a result of your own actions.

Because of the mechanical stresses caused during rotation, some experienced constructors feel that the magnets should be embedded in the rotor as shown here where they are kept well clear of the rim of a rotor which is made from a tough material. This is so that the outer strip of the material prevents the magnets breaking loose and becoming dangerous high-speed projectiles, which at best would destroy the electromagnets and at worst could injure someone quite badly:

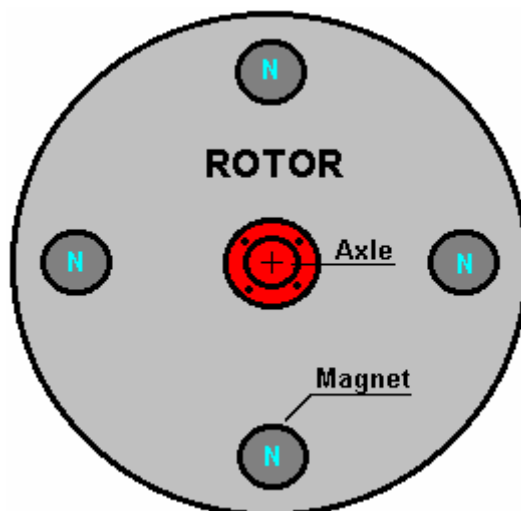

It needs to be remembered that the proportions of the magnets are for the magnet length to be more than the diameter, so in cases like this where circular magnet faces are to be used, the magnets will be cylindrical and the rotor needs to have a significant thickness, which will depend on the magnets which are available locally. The magnets should be a tight push-fit in their holes and securely glued in place.

Robert Adams has used this construction style as well. However, if an arrangement like this is used, then there will be a substantial sideways pull on the rotor as it reaches the electromagnet core, tending to pull the magnets out of the rotor.

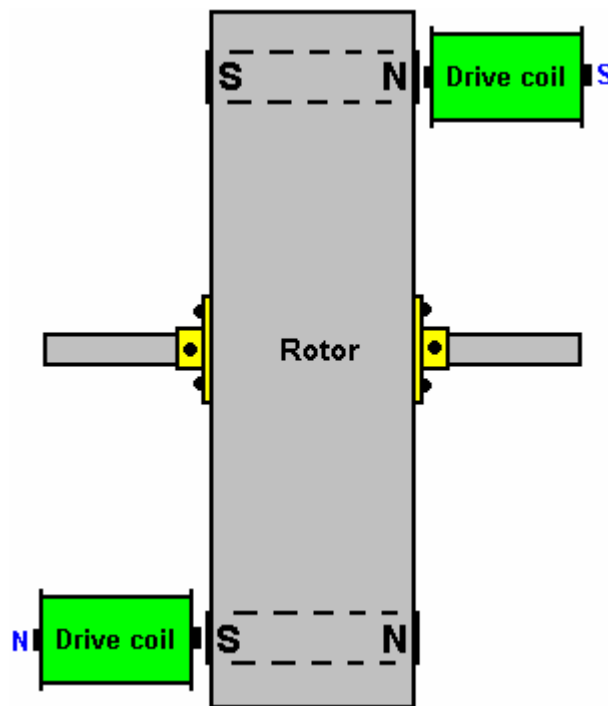

It is important that the rotor should be perfectly balanced and have the minimum amount of bearing friction possible. This calls for precision construction and either roller or ball bearings. The construction style shown above has the distinct advantage that it has an open end to both the magnet and the coils and this is believed to facilitate the inflow of environmental energy into the device.

It may be my ignorance showing here, but I have a problem with this version. The difficulty as I see it is that the magnet/core pull and the subsequent drive thrust when the coil is powered, form a "turning couple" as they both try to rotate the axle in the same direction. This places a substantial loading on the axle bearings, usually amplified by the radius of the rotor being greater than the distance from the rotor to the axle bearings. This load will be in the tens of kilograms range and will be applied and reversed perhaps forty times per second. To me, that appears like a vibration load and is directly opposed to the "perfectly balanced" rotor operation being sought. The radial magnet arrangement generally shown by Robert Adams does not have any of this kind of loading at all because the coils are exactly opposite each other and their loads cancel each other out exactly. The choice is, of course, up to the builder and his assessment of the advantages and disadvantages of the different styles of construction.

When getting ball-race bearings for an application like this, please be aware that "closed" bearings such as these are not suitable as supplied:



This is because this type of bearing is usually packed with dense grease which completely destroys its free motion, making it worse as a bearing than a simple hole-and-shaft arrangement. However, in spite of this, the

closed or "sealed" bearing is popular as the magnets tend to attract dirt and dust and if the device is not enclosed in a steel box as is necessary for the high power versions, then having the seal is considered to be an advantage. The way to deal with the grease packing is to soak the bearing in an isopropyl solvent cleaner to remove the manufacturer's grease, and then, when it has dried out, lubricate the bearing with two drops of a high quality thin oil. If it is intended to house the motor/generator in an earthed, sealed steel box then an alternative type of bearing which might be suitable is an open design like this:



especially if the air is removed from the box. Some constructors prefer to use ceramic bearings which are supposed to be immune to dirt. One supplier is <http://www.bocabearings.com/main1.aspx?p=docs&id=16> but as with everything else, these choices have to be made by the builder and will be influenced by his opinions.

I'm not sure where it came from, but here is a circuit diagram showing a transistor drive and the return of the back EMF of the drive coils to the driving power supply. Using this method, about 95% of the drive current can be returned, lowering the current draw enormously:

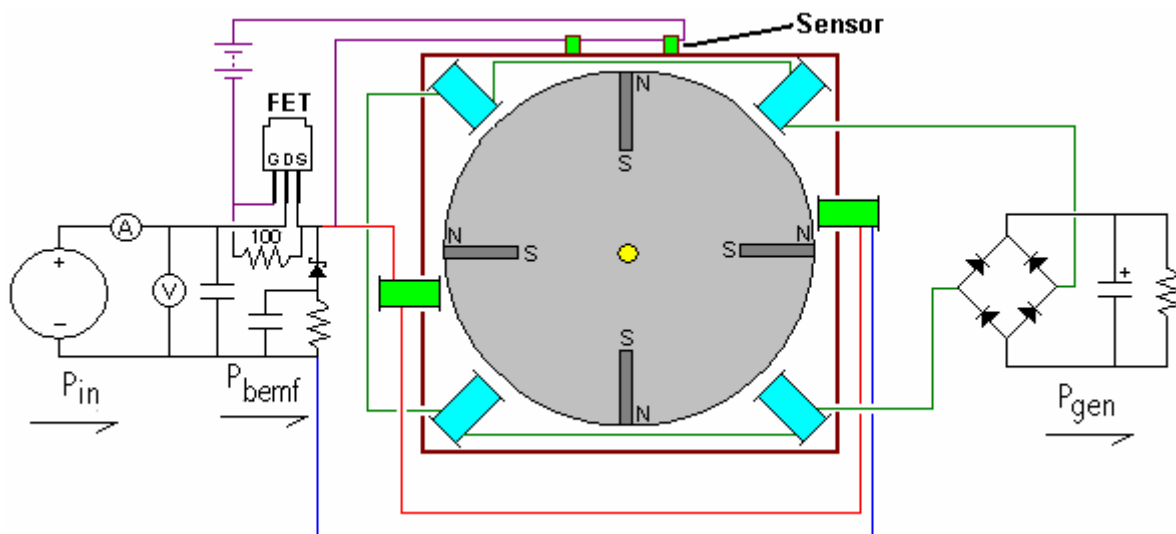

The diode feeding the power back to the supply is a Schottky type because of its high-speed operation. It needs to be able to handle the peak pulse power and so should be one of the more robust types. What this circuit does not have is the very important switching on the output coils circuit. Another strange item is the way that the FET sensor is arranged with two sensors rather than one and with an additional battery. While it must be admitted that the current draw of the FET gate should be very low, there still does not seem to be much reason to have a second power supply. One other peculiarity in this diagram is the positioning of the drive coils. With them offset as shown, it has the effect of them being at an angle relative to the rotor magnets. It is not at all clear if this is an advanced operating technique or just poor drawing - I am inclined to assume the latter although I have no evidence for this other than the circuit design and the low quality of the original drawing which had to be improved considerably to arrive at the diagram shown above.

The coil generator output should be fed into a capacitor before being passed to whatever equipment is to be powered by the device. This is because the energy is being drawn from the local environment and is not conventional energy. Storing it in a capacitor converts it to a more normal version of electrical power, a feature which has also been mentioned by Don Smith and by John Bedini although their devices are quite different in operation.

The DC resistance of the coil windings is an important factor. The overall resistance should be either 36 ohms or 72 ohms for a complete set of coils, whether they are drive coils or power pick-up coils. Coils can be wired in parallel or in series or in series/parallel. So, for 72 ohms with four coils, the DC resistance of each coil could be 18 ohms for series-connected, 288 ohms for parallel connected, or 72 ohms for connection in series/parallel where two pairs of coils in series are then wired in parallel.

To help with assessing the wire diameter and length which you could use, here is a table of some of the common sizes in both American Wire Gage and Standard Wire Gauge:

AWG	Dia mm	SWG	Dia mm	Max Amps	Ohms / 100 m
11	2.30	13	2.34	12	0.53
12	2.05	14	2.03	9.3	0.67
13	1.83	15	1.83	7.4	0.85
14	1.63	16	1.63	5.9	1.07
15	1.45	17	1.42	4.7	1.35
16	1.29	18	1.219	3.7	1.70
18	1.024	19	1.016	2.3	2.7
19	0.912	20	0.914	1.8	3.4
20	0.812	21	0.813	1.5	4.3
21	0.723	22	0.711	1.2	5.4
22	0.644	23	0.610	0.92	6.9
23	0.573	24	0.559	0.729	8.6
24	0.511	25	0.508	0.577	10.9
25	0.455	26	0.457	0.457	13.7
26	0.405	27	0.417	0.361	17.4
27	0.361	28	0.376	0.288	21.8
28	0.321	30	0.315	0.226	27.6
29	0.286	32	0.274	0.182	34.4
30	0.255	33	0.254	0.142	43.9
31	0.226	34	0.234	0.113	55.4
32	0.203	36	0.193	0.091	68.5
33	0.180	37	0.173	0.072	87.0
34	0.160	38	0.152	0.056	110.5
35	0.142	39	0.132	0.044	139.8

So far, we have not discussed the generation of the timing pulses. A popular choice for a timing system is to use a slotted disc mounted on the rotor axle and sensing the slots with an "optical" switch. The "optical" part of the switch is usually performed by UV transmission and reception and as ultra violet is not visible to the human eye, describing the switching mechanism as "optical" is not really correct. The actual sensing mechanism is very simple as commercial devices are readily available for performing the task. The sensor housing contains both a UV LED to create the transmission beam, and a UV dependent resistor to detect that transmitted beam.

Here is an example of a neatly constructed timing mechanism made by Ron Pugh for his six-magnet rotor assembly:

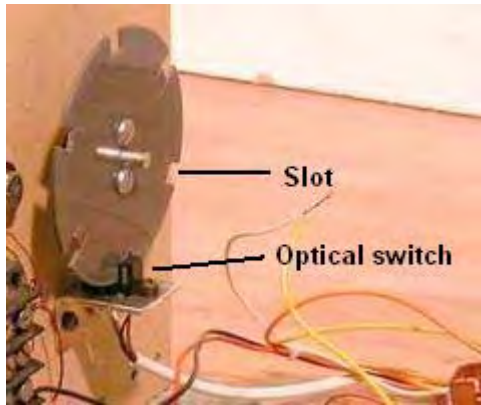

and the switch/sensor:

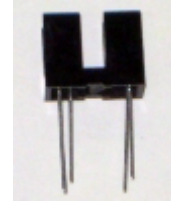

This device happens to be one which is supplied by www.bayareaamusements.com under their product code number : OP-5490-14327-00. As the slotted disc rotates, one of the slots comes opposite the sensor and allows the UV beam to pass through to the sensor. That lowers the resistance of the sensor device and that change is then used to trigger the drive pulse for whatever length of time the slot leaves the sensor clear. You will notice the balanced attachment method used by Ron to avoid having an unbalanced rotor assembly. There can be two timing discs, one for the drive pulses and one for switching the power pickup coils in and out of the circuit. The slots in the power pick-up timing disk will be very narrow as the switch-on period is only about 2.7 degrees. For a six-inch diameter disc where 360 degrees represents a circumference length of 18.85 inches (478.78 mm) a 2.7 degree slot would be only 9/64 inch (3.6 mm) wide. The arrangement for an axial magnet rotor set-up could be like this:

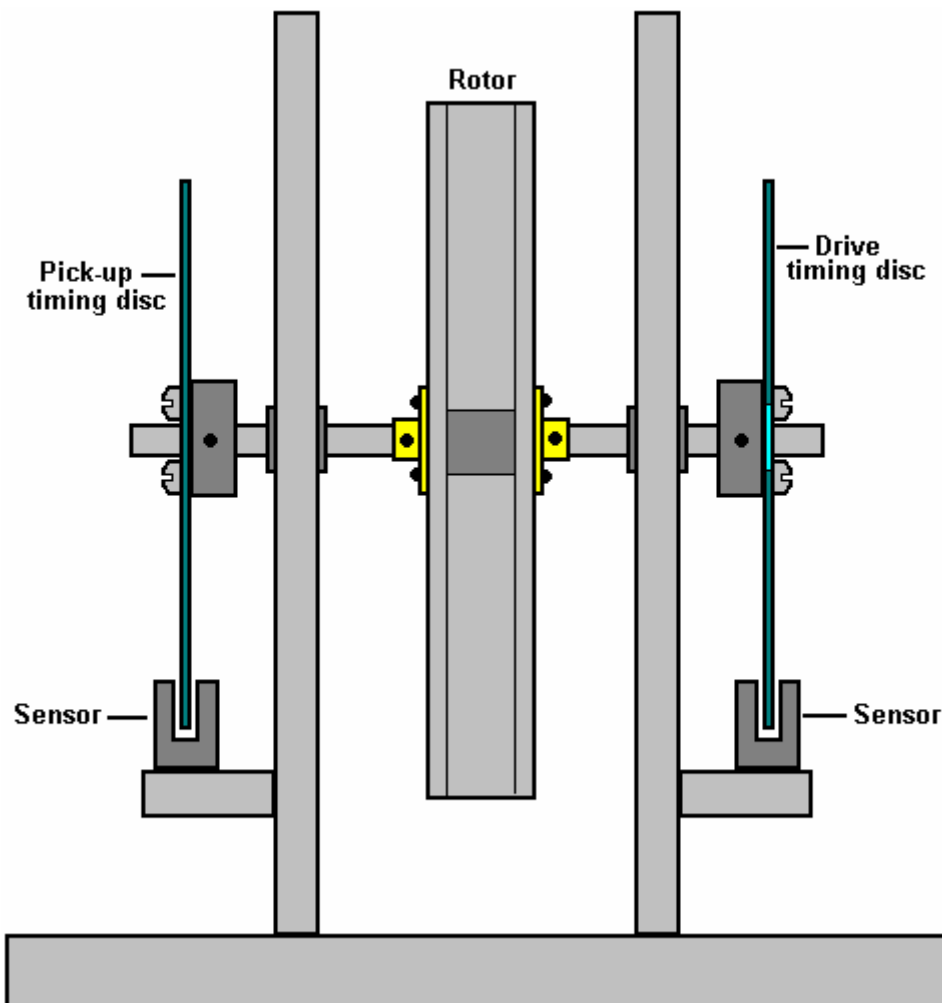

So to recap, the things which are necessary for getting an Adams Motor output into the serious bracket are:

1. A performance of COP>1 can only be achieved if there are power pick-up coils.

2. The rotor magnets need to be longer than they are wide in order to ensure the correct magnetic field shape and the rotor must be perfectly balanced and have bearings as low-friction as possible.
3. The face area of the rotor magnets needs to be four times that of the drive coil cores and one quarter the area of the core of the power pick-up coils. This means that if they are circular, then the drive coil core diameter needs to be half the diameter of the magnet and the magnet diameter needs to be half the diameter of the power pick-up core. For example, if a circular rotor magnet is 10 mm across, then the drive core should be 5 mm across and the pick-up core 20 mm across.
4. The drive voltage needs to be a minimum of 48 volts and preferably, a good deal higher than that.
5. Do not use neodymium magnets if the drive voltage is less than 120 volts.
6. The drive coils should not be pulsed until they are exactly aligned with the rotor magnets even though this does not give the fastest rotor speed.
7. Each complete set of coils should have a DC resistance of either 36 ohms or 72 ohms and definitely 72 ohms if the drive voltage is 120 volts or higher.
8. Collect the output power in large capacitors before using it to power equipment.

It may also be possible to boost the output power further, by using the Coil-Shorting technique shown in the section of this chapter on the RotoVerter.

If you want the original drawings and some explanation on the operation of the motor, then two publications from the late Robert Adams can be bought from www.nexusmagazine.com where the prices are quoted in Australian dollars, making the books look much more expensive than they actually are.

<http://www.totallyamped.net/adams/index.html> is a really impressive collection of well-informed practical material on building and using an Adams motor with details of sensors and how they work, core materials and their performances and how to locate the "sweet spot" - very highly recommended web site.

Phemax's Inertial-Propulsion and Electrical Generation System.

Phemax Technologies, Inc. have developed what they describe as their 'sustainable transportation system' which is based on their inertial-propulsion generation wheel, which uses what they call '3-D Coraxial Hybrid Induction' (CHI), in which 'Coraxial' refers to their "combined radial-axial" technique where drive is provided by a radial pulsed magnet system and power extraction is achieved using an axially-orientated magnet/coil system.

Taiwan inventor, Tajen (David) Chi, says that his company, "Phemax Technologies Inc." will be demonstrating their technology in September 2010 an expo, after which they will allow interested and qualified parties to come to their premises for licensing discussions.

Their device can take the place of the battery component of an electric vehicle or it can be used to supplement and recharge a battery bank in the vehicle. At the September exhibition, they will allow visitors to ride their 2 kW test car. David intends to put their test data on the Internet. With a rotational input of 1 NM at 500 rpm, a single inertial-propulsion generation wheel can produce 1 KW of axial generative power.



Vice President and Chief Technology Officer, Michael Hsueh and Sales Manager, Sabrina Li

David also said that a 150W output from his motor actually produces between 180 and 200 watts of mechanical output, while a 1500W output produces a mechanical output of 1800 to 2000 watts (96 Volts at 20 Amps), as measured by a watt meter, speed meter, torque meter, and oscilloscopes. He says that these measurements were made by Michael Hseuh, Vice President and Chief Technology Officer.

Ceramic-based and carbon-based ultra-capacitors are used to return some of the output power to the input in order to keep the machine running continuously without the need for a power supply when the engine is running and providing it's output. When driving a vehicle powered by this device, the mechanical driving torque is provided via a continuously-variable transmission.

At this time, Phemax Technologies, Inc. have a 150-Watt and a 2 kW prototype which they plan to demonstrate in September 2010. He says that they generally run these prototypes for eight hours each day in their lab. The central principle of the Phemax Technologies Inc. process is what they call "CORAXIA" which stands for "combined radial-axial" hybrid induction, abbreviated to "CHI", which is David's surname. They also call this the "3-D Coaxial Hybrid Induction" system. They state that their electromagnetic 3-D arrangement enables the wheel to have both radial flux propulsion and axial flux generation with just a single rotor and two separate stators. As the radial electric drive rotates, the mechanical energy due to the inertia of the wheel and the ground power transmission mechanism enables the wheels of a vehicle to generate electricity as they rotate.

There are two videos showing the device generating electricity, located here:

http://www.youtube.com/watch?v=W_lzhpZxxcQ and

<http://www.youtube.com/watch?v=O8frdR-fnO> here.

Another application is where the electrical output from the device is being used to produce a hydrogen/oxygen gas mix from water using an underwater plasma arc:

David says he is self-taught in this area. He has three patents: Taiwan patent M352472, M372891 and M382655 (which are not in English). From his search of the patent index, the Internet and YouTube, David said he has not yet seen a patent or experimental set-up similar to what they have developed.

This motor/generator is unusual in that it uses pulsed rotor drive on magnets mounted on the circumference of the rotor and simultaneously, it picks up electrical energy from a coil/magnet arrangement mounted on the side faces of the rotor as shown here:

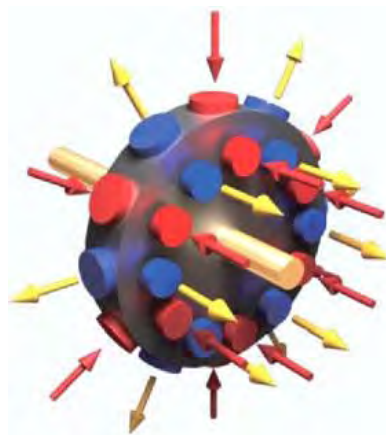
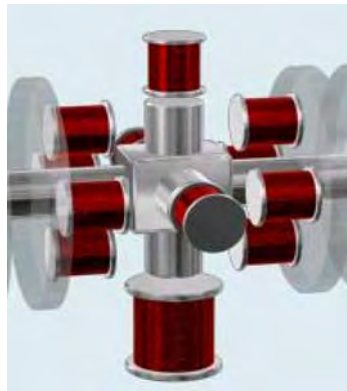

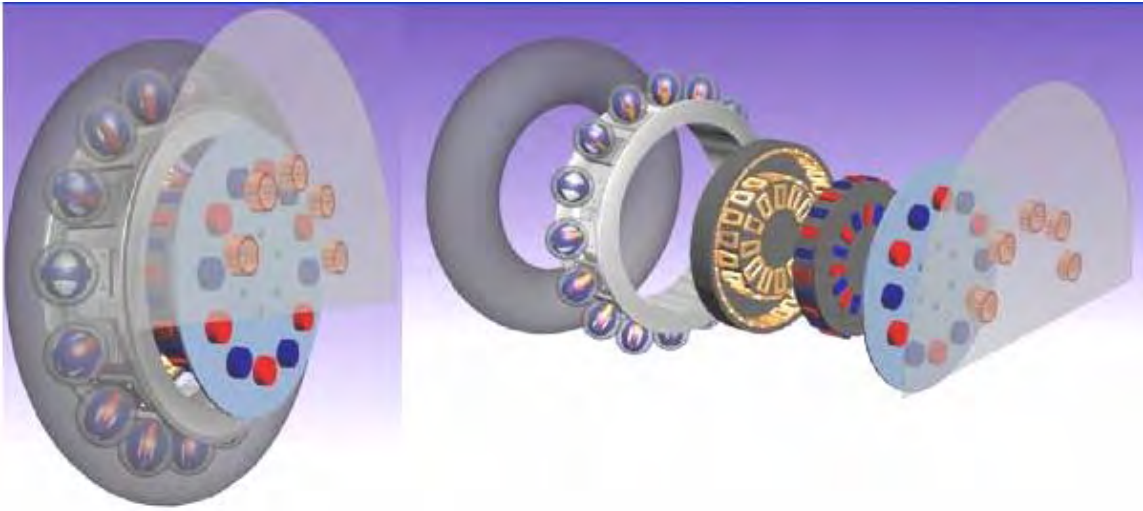

The basic drive/generator unit can be replicated on a single shaft to give increased power, still without increased frictional losses between the drive and the power generation:



It is unusual to see this technique used as it can be difficult to avoid interaction between the different magnetic fields. However, David has been entirely successful in doing this and the arrangement has no transmission losses between the drive motor and the generator as these are integral components of the system.

This system is capable of driving a self-powered air-conditioning unit and a 5 kW proof-of-concept prototype is shown here:



This device is also capable of driving electric lighting and with a 5 kilowatt output self-powered output, it can power most household needs. A typical washing machine has a 2.25 kilowatt maximum electrical draw as does the average tumble-dryer. Most fan-heaters are 3 kilowatts or less when on full output.

If a wind-power generator is already in place, then using the mechanical power of the generator to spin the axle of one of these CHI generators results in a very high-power electricity generation system.

Contact: Tajen (David) Chi, Taiwan email: chitajen@gmail.com

Inquiries to: Phemax Technologies Inc., Michelle Chen, Manager of Marketing and Business Development.
Tel: 886-2-2371-5622 e-mail: michelle@phemax.com

Raymond Kromrey's Electrical Generator.

Where the objective is to produce electricity from a rotating magnetic field, there has always been a search for some method of either reducing, or eliminating altogether, the drag on the rotor when electric current is drawn from the generator. One design which claims to have very limited drag caused by current draw is the Kromrey design. The main characteristics of this design are said to be:

1. It has almost constant electrical power output even when the rotor speed is altered by as much as 35%.
2. It can continue to operate with it's electrical output short-circuited, without heating the rotor or causing a braking effect.
3. The production efficiency (electrical output divided by the driving force) is high.
4. The frequency of it's AC output power can be adjusted to that required by the equipment which it powers.
5. The rotor can be spun at any rate from 800 rpm to 1,600 rpm.
6. The simple construction allows manufacturing costs to be about 30% less than other generators.
7. This generator is recommended for supplying power at or above the 1 kilowatt level.

Here is the patent for this device:

Patent US 3,374,376

19th March 1968

Inventor: Raymond Kromrey

ELECTRIC GENERATOR

My present invention relates to an electric generator which converts magnetic energy into electric energy using two components which can rotate relative to each other, i.e. a stator and a rotor, one having electromagnets or permanent magnets which induce a voltage in a winding which forms part of an output circuit mounted on the other component.

Conventional generators of this type use a winding which whose conductors form loops in different axial planes so that opposite parts of each loop pass through the field of each pole pair, twice per revolution. If the loops are open circuit, then no current flows in the winding and no reaction torque is developed, leaving the rotor free to turn at the maximum speed of its driving unit. As soon as the output winding is connected across a load or is short-circuited, the resulting current flow tends to retard the motion of the rotor to an extent which depends on the intensity of the current and this makes it necessary to include compensating speed-regulating devices if it is necessary to maintain a reasonably constant output voltage. Also, the variable reaction torque subjects the rotor and its transmission to considerable mechanical stresses and possible damage.

It is therefore the general object of this invention to provide an electric generator which has none of the above disadvantages. Another object is to provide a generator whose rotor speed varies very little in speed between open circuit operation and current delivery operation. Another objective is to provide a generator whose output voltage is not greatly affected by fluctuations in its rotor speed.

I have found that these objectives can be achieved by rotating an elongated ferromagnetic element, such as a bar-shaped soft-iron armature, and a pair of pole pieces which create an air gap containing a magnetic field. Each of the outer extremities of the armature carries a winding, ideally, these windings are connected in series, and these coils form part of a power output circuit used to drive a load. As the armature rotates relative to the air gap, the magnetic circuit is intermittently completed and the armature experiences periodic remagnetisations with successive reversals of polarity.

When the output circuit is open, the mechanical energy applied to the rotor (less a small amount needed to overcome the friction of the rotating shaft) is absorbed by the work of magnetisation, which in turn, is dissipated as heat. In actual practice however, the resulting rise in temperature of the armature is hardly noticeable, particularly if the armature is part of the continuously air-cooled rotor assembly. When the output circuit is closed, part of this work is converted into electrical energy as the current flow through the winding opposes the magnetising action of the field and increases the apparent magnetic reluctance of the armature, and so the speed of the generator remains substantially unchanged if the output circuit is open or closed.

As the armature approaches its position of alignment with the gap, the constant magnetic field tends to accelerate the rotation of the armature, aiding the applied driving force. After the armature passes through the gap there is a retarding effect. When the rotor picks up speed, the flywheel effect of its mass overcomes these fluctuations in the applied torque and a smooth rotation is experienced.

In a practical embodiment of this invention, the magnetic flux path includes two axially spaced magnetic fields traversing the rotor axis and substantially at right angles to it. These fields are generated by respective pole pairs co-operating with two axially spaced armatures of the type already described. It is convenient to arrange these two armatures so that they lie in a common axial plane and similarly, the two field-producing pole pairs also lie in a single plane. The armatures should be laminated to minimise eddy currents, so they are made of highly permeable (typically, soft-iron) foils whose principle dimension is perpendicular to the rotor axis. The foils can be held together by rivets or any other suitable method.

If the ferromagnetic elements are part of the rotor, then the output circuit will include the usual current-collecting means, such as slip-rings or commutator segments, depending on whether AC or DC current output is desired. The source of coercive force in the stator includes, advantageously, a pair of oppositely positioned, yoke-shaped magnets of the permanent or electrically energised type, whose extremities constitute the pole pieces mentioned above. If electromagnets are used in the magnetic circuit, then they may be energised by an external source or by direct current from the output circuit of the generator itself.

I have found that the terminal voltage of the output circuit does not vary proportionately to the rotor speed as might be expected, but instead, it drops at a considerably slower rate with decreasing rotor speed. So, in a particular tested unit, this voltage fell to only about half its original value when the rotor speed was dropped to one third. This non-linear relationship between terminal voltage and driving rate produces a substantially constant load current and therefore, electric output over a wide speed range, at least under certain load conditions, inasmuch as the inductive reactance of the winding is proportional to frequency (and consequently, to rotor speed) so as to drop off more rapidly than the terminal voltage, in the event of a speed reduction, with a resulting improvement in the power factor of the load circuit.

If the magnetic circuit contains only a single pole pair per air gap, the flux induced in the rotating armature will change its direction twice per revolution so that each revolution produces one complete cycle of 360 electrical degrees. In general, the number of electrical degrees per revolution will equal 360 times the number of pole pairs, it being apparent that this number ought to be odd since with even numbers it would not be possible to have poles alternating in polarity along the path of the armature and at the same time to have the North and South poles of each pair at diametrically opposite locations. In any case, it is important to dimension the curved facing faces of the pole pairs in such a manner so as to avoid allowing the armature to bridge between adjoining poles, so it is necessary to make the sum of the arcs spanned by these faces (in the plane of rotation) equal to considerably less than 360 degrees electrical.

The invention will now be described in more detail, reference being made to the accompanying drawings in which:

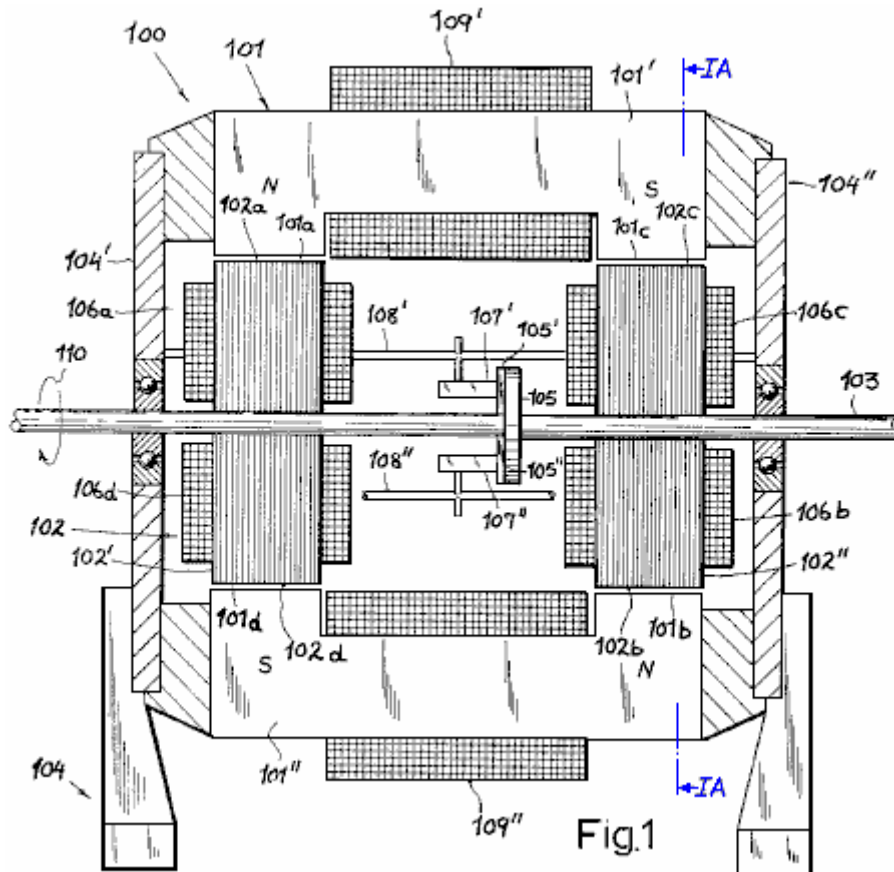

Fig.1

Fig.1 and Fig1A. illustrate a first embodiment of my invention, shown in axial section and in a cross-sectional view taken on line IA - IA of Fig.1 respectively.

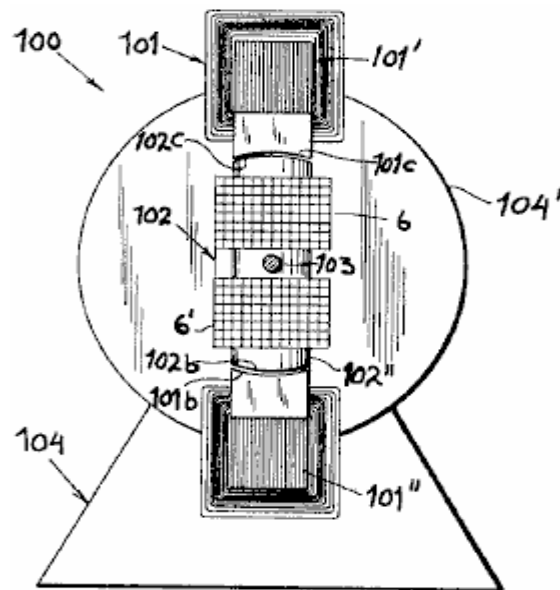

Fig.1A

Fig.2 and Fig.3 are perspective views illustrating two other embodiments.

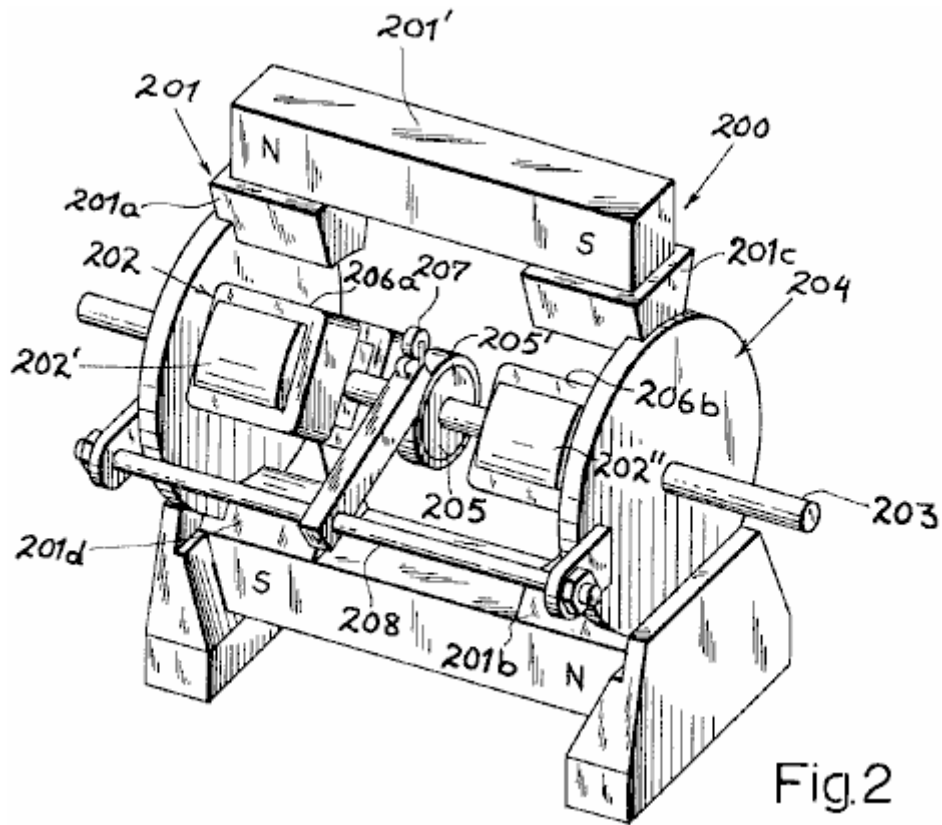

Fig.2

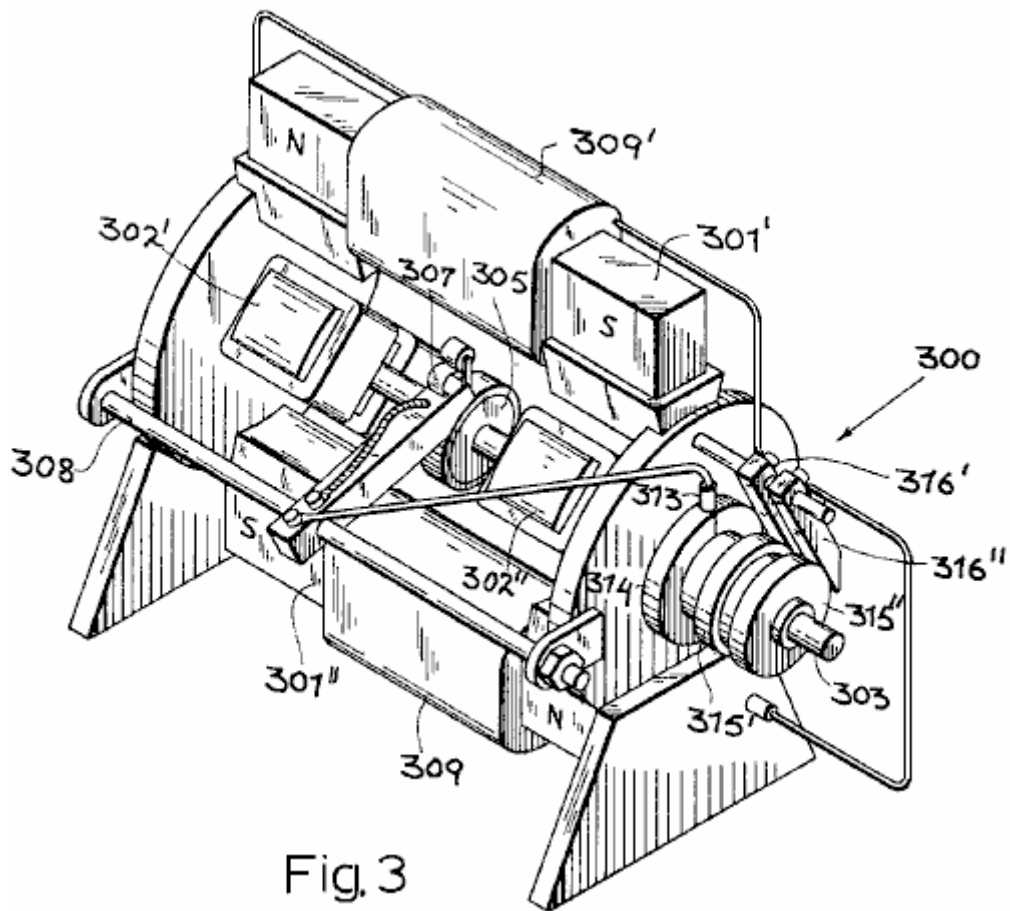

Fig.3

Fig.4 and **Fig.5** illustrate diagrammatically, two output circuit arrangements, one for a DC output and one for an AC output.

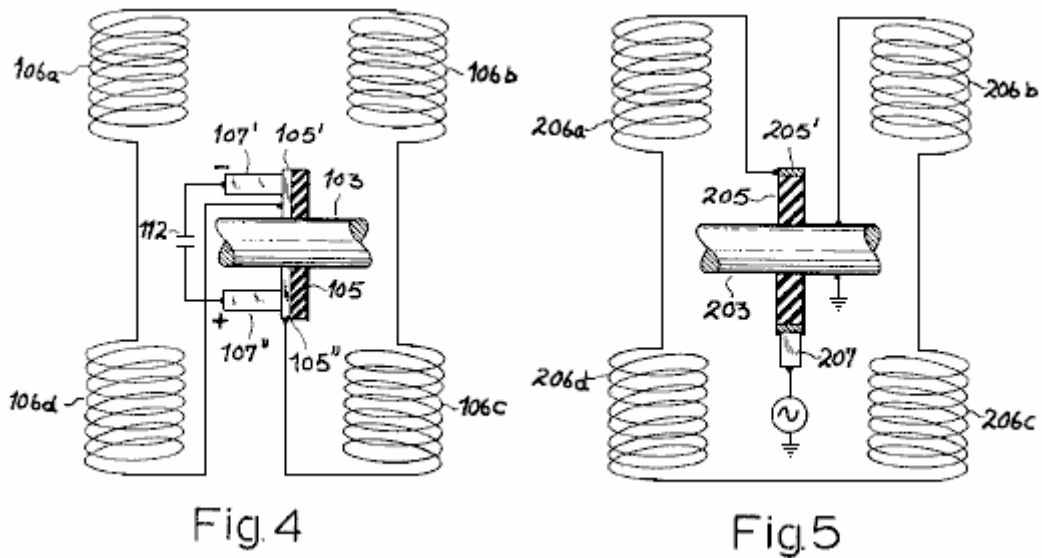
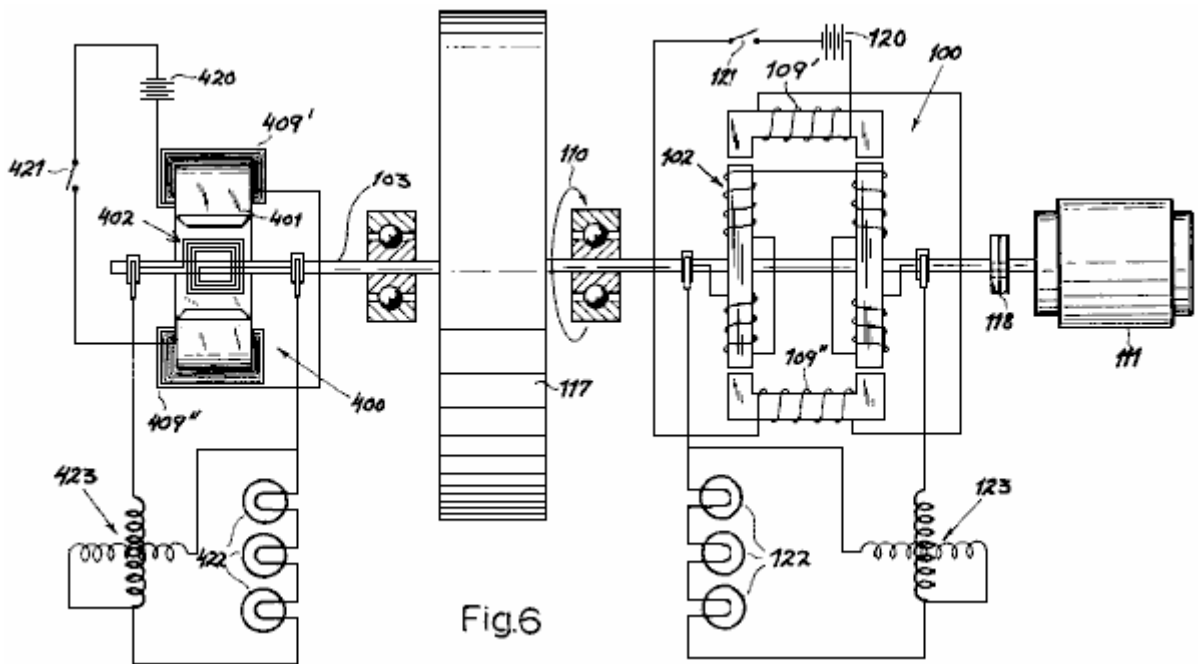

Fig.6 is a somewhat diagrammatic illustration of an arrangement for comparing the outputs of a conventional generator and a generator according to this invention.



The generator **100** shown in **Fig.1** and **Fig.1A** comprises a stator **101** and a rotor **102** which has a pair of laminated armatures **102'** and **102''**, carried on a shaft **103** which is free to rotate in bearings mounted in the end plates **104'** and **104''**, of a generator housing **104** which is made from non-magnetic material (e.g. aluminium) which is rigidly attached to the stator.

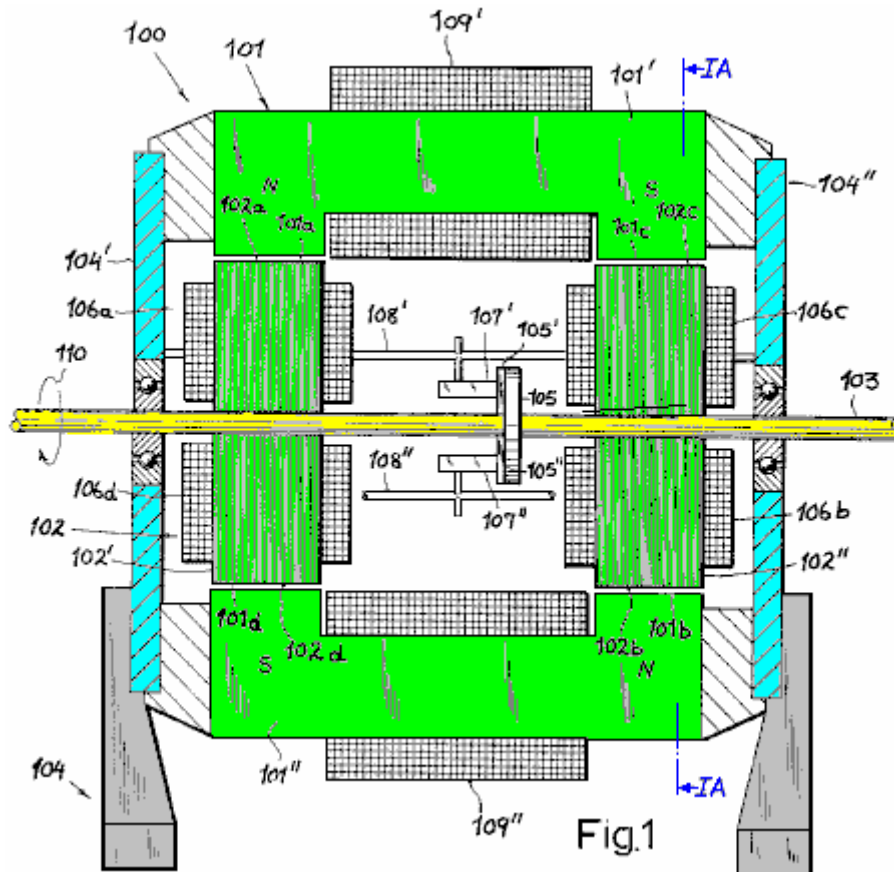

Fig.1

Shaft **103** is coupled to a source of driving power indicated diagrammatically by an arrow **110**. The stator **101** includes a pair of yoke-shaped laminated electromagnets **101'** and **101''** whose extremities form two pairs of coplanar pole pieces, designated respectively **101a**, **101b** (North magnetic pole) and **101c**, **101d** (South magnetic pole). The pole pieces have concave faces, facing towards the complimentary convex faces **102a**, **102d** of armature **102'** and **102b**, **102c** of armature **102''**. These faces whose concavities are all centred on the axis of shaft **103**, extend over arcs of approximately 20° to 25° each in the plane of rotation (**Fig.1A**) so that the sum of these arcs adds up to about 90° geometrically and electrically.

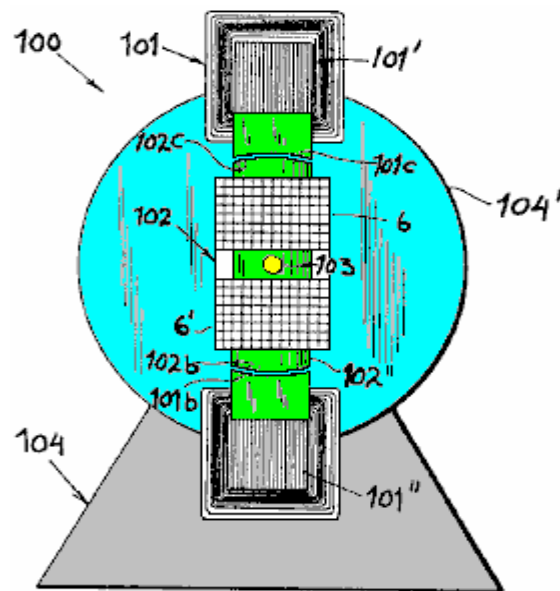

Fig.1A

The stator magnets **101'**, **101''** are surrounded by energising windings **109'**, **109''** which are connected across a suitable source of constant direct current (not shown). Similar windings, each composed of two series-connected coils **106a**, **106d** and **106b**, **106c**, surround the rotor armatures **102'** and **102''**, respectively. These coils form

part of an output circuit which further includes a pair of brushes **107'**, **107''** which are carried by arms **108'**, **108''** on housing **104** with mutual insulation brushes **107'**, **107''** co-operate with a pair of commutator segments **105'**, **105''** (see also **Fig.4**) which are supported by a disc of insulating material **105**, mounted on shaft **103**.

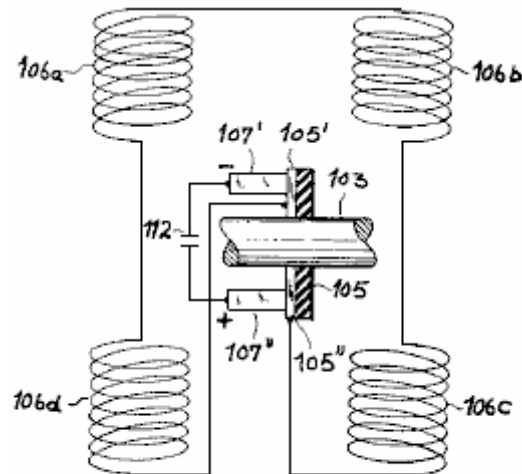

Fig. 4

By virtue of the series-connection of coils **106a-106d** between the segments **105'** and **105''**, as illustrated in **Fig.4**, the alternating voltage induced in these coils gives rise to a rectified output voltage at brushes **107'** and **107''**. The unidirectional current delivered by these brushes to a load (not shown) may be smoothed by conventional means, represented by capacitor **112** in **Fig.4**.

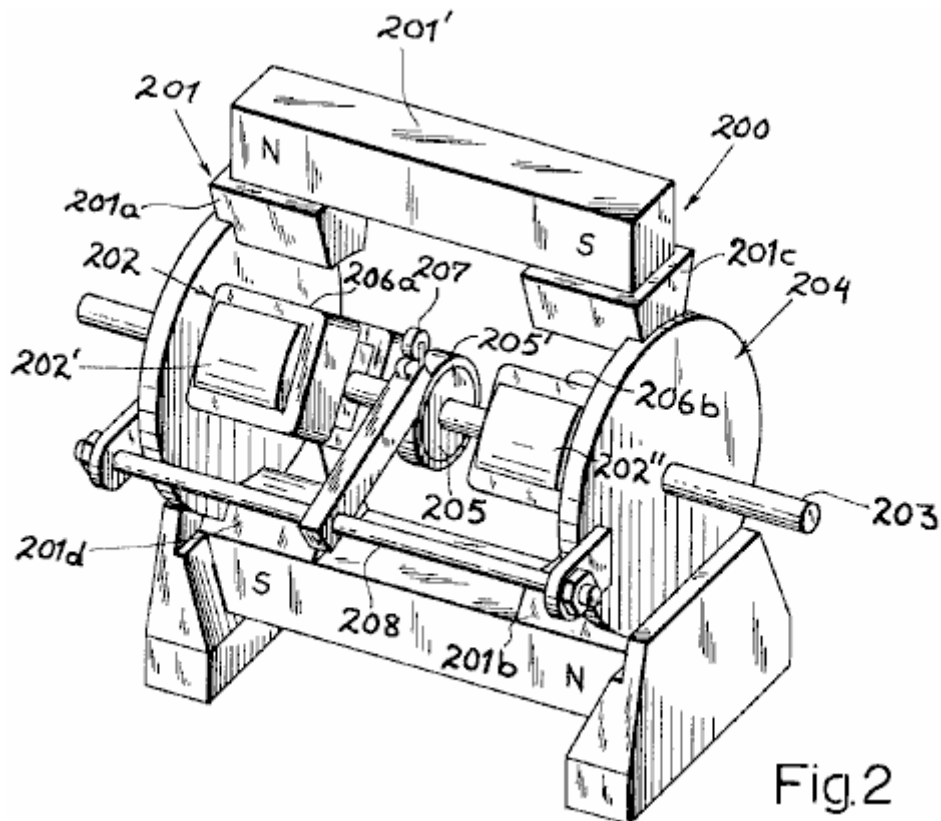

Fig.2

Fig.2, shows a modified generator **200**, whose housing **204**, supports a stator **201** essentially consisting of two permanent bar magnets **201'** and **201''**, extending parallel to the drive shaft **203** (on opposite side of it), each of these magnets being rigid and each having a pair of sole shoes **201a**, **201c** and **201b**, **201d** respectively. Rotor

202 is a pair of laminated armatures 202' and 202", similar to those of the previous embodiment, whose output coils 206a, 206b, 206c and 206d are serially connected between a slip-ring 205', supported on shaft 203 through the intermediary of an insulating disc 205, and another terminal here represented by the grounded shaft 203 itself. Slip-ring 205' is contacted by brush 207 on holder 208, the output of this brush being an alternating current of a frequency determined by the rotor speed.

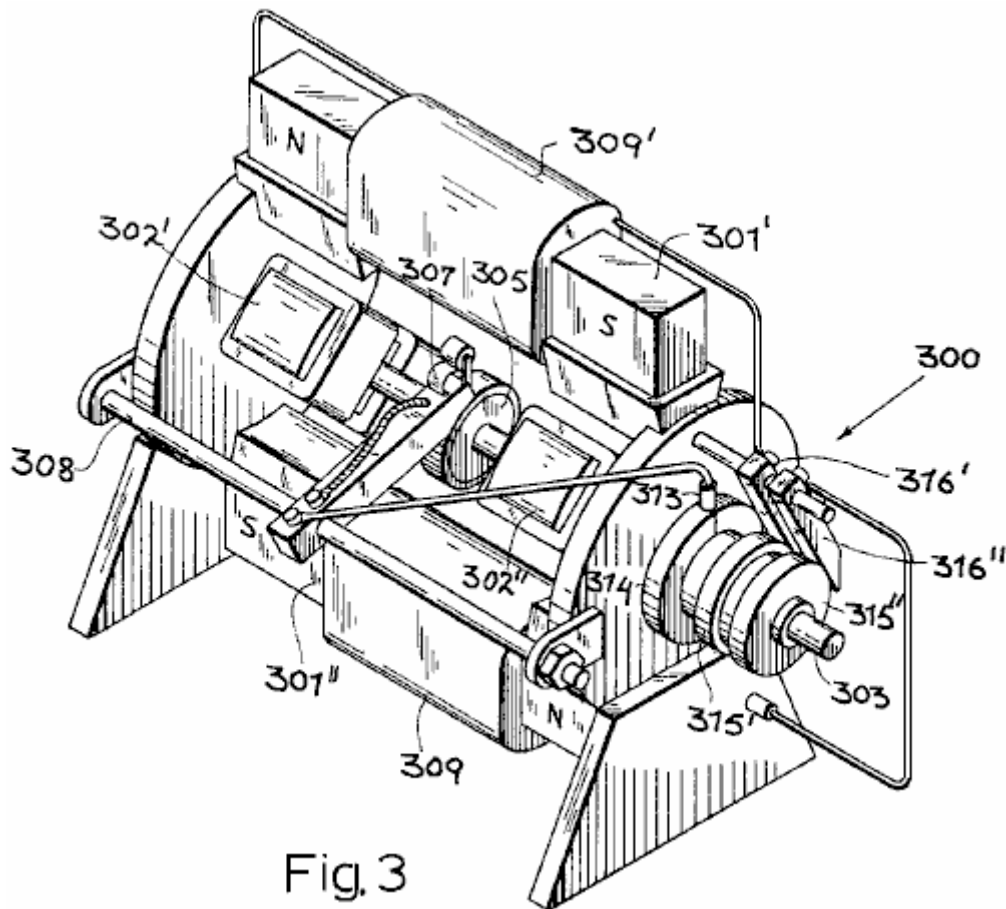

Fig.3 shows a generator 300 which is basically similar to the generator 100 shown in **Fig.1** and **Fig.1A**. Its shaft 303 carries a pair of laminated soft-iron armatures 302', 302" which can rotate in the air gaps of a pair of electromagnets 301', 301" which have windings 309' and 309". The commutator 305 again co-operates with a pair of brushes 307, only one of which is visible in **Fig.3**. This brush, carried on an arm 308, is electrically connected to a brush 313 which engages with a slip-ring 314 positioned on an extremity of shaft 303 which also carries two further slip-rings 315', 315" which are in conductive contact with ring 314 but are insulated from the shaft. Two further brushes 316', 316" contact the rings 315', 315" and respectively are connected to windings 309' and 309". The other ends of these windings are connected to an analogous system of brushes and slip-rings on the extremity of the opposite shaft, and arranged so that the two commutator brushes are effectively bridged across the windings 309' and 309" in parallel. Therefore, in this embodiment, the stator magnets are energised from the generator output itself, it being understood that the magnets 301' and 301" (made, for example, of steel rather than soft iron) will have a residual coercive force sufficient to induce an initial output voltage. Naturally, the circuits leading from the brushes 307 to the windings 309', 309" may include filtering as described in connection with **Fig.4**.

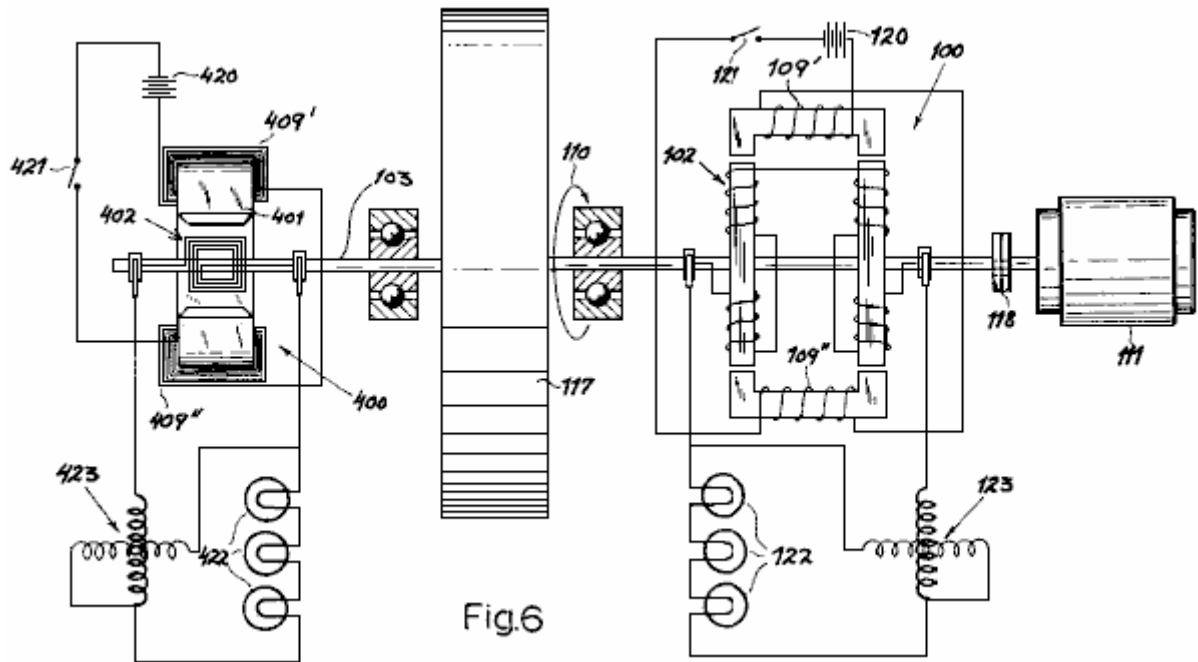

Fig.6

Fig.6 shows a test circuit designed to compare the outputs of a generator of this design, such as the unit **100** of **Fig.1** and **Fig.1A**, with a conventional generator **400** of the type having a looped armature **402** which rotates in the gap of a stator magnet **401** which is fitted with energising windings **409'**, **409''**. The two generators are interconnected by a common shaft **103** which carries a flywheel **117**. This shaft is coupled through a clutch **118** to a drive motor **111** which drives the rotors **402** and **102** of both generators in unison, as indicated by arrow **110**. Two batteries **120** and **420**, in series with switches **121** and **421**, represent the method of supplying direct current to the stator windings **109'**, **109''** and **409'**, **409''** of the two generators.

The rectified output of generator **100** is delivered to a load **122**, shown here as three incandescent lamps connected in series, and with a combined consumption of 500 watts. Generator **400**, provides current into an identical load **422**. Two watt meters **123** and **423** have their voltage and current windings connected respectively in shunt and in series with their associated loads **122** and **422**, to measure the electric power delivered by each generator.

When clutch **118** is engaged, shaft **113** with it's flywheel **117** is brought to an initial driving speed of 1,200 rpm. at which point, the switch **421** in the energising circuit of the conventional generator **400**, is closed. The lamps **422** light immediately and the corresponding wattmeter **423** shows an initial output of 500 watts. However, this output drops immediately as the flywheel **117** is decelerated by the braking effect of the magnetic field on armature **402**.

Next, the procedure is repeated but with switch **421** open and switch **121** closed. This energises generator **100** and the lamps **122** light up, wattmeter **123** showing an output of 500 watts, which remains constant for an indefinite period of time , there being no appreciable deceleration of flywheel **117**. When the clutch **118** is released and the rotor speed gradually decreases, the output of generator **100** is still substantially 500 watts at a speed of 900 rpm. and remains as high as 360 watts when the speed dropped further to 600 rpm. In a similar test with a generator of the permanent magnet type, such as the one shown at **200** in **Fig.2**, a substantially constant output was observed over a range of 1600 to 640 rpm.

Teruo Kawai's COP=1.6 Magnetic Motor.

In July 1995, a patent was granted to Teruo Kawai for an electric motor. In the patent, Teruo states that a measured electrical input 19.55 watts produced an output of 62.16 watts, and that is a COP of 3.18. The main sections of that patent are included in the Appendix.

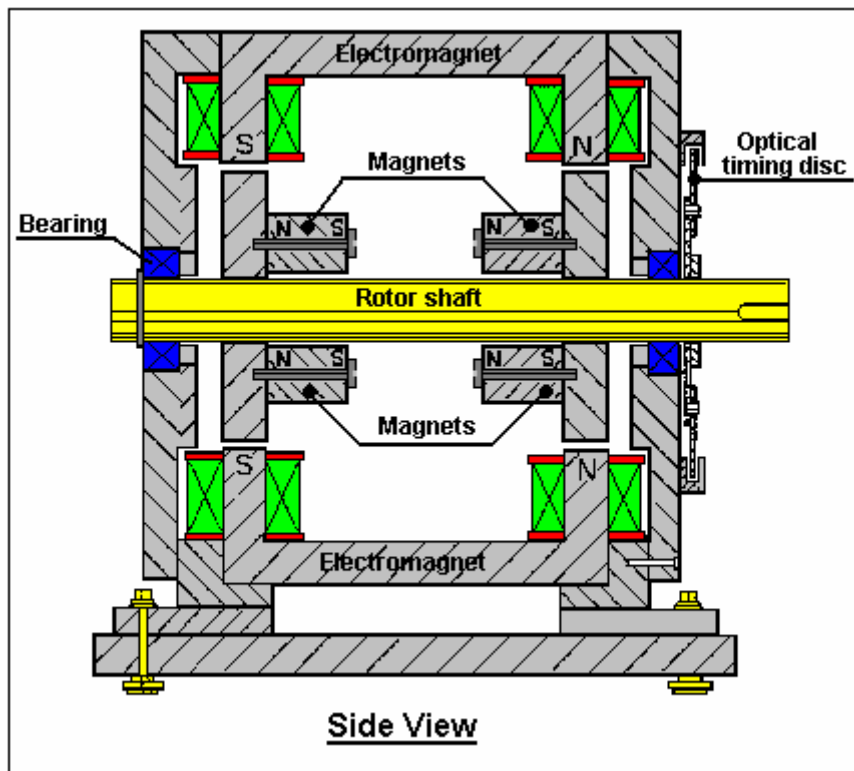
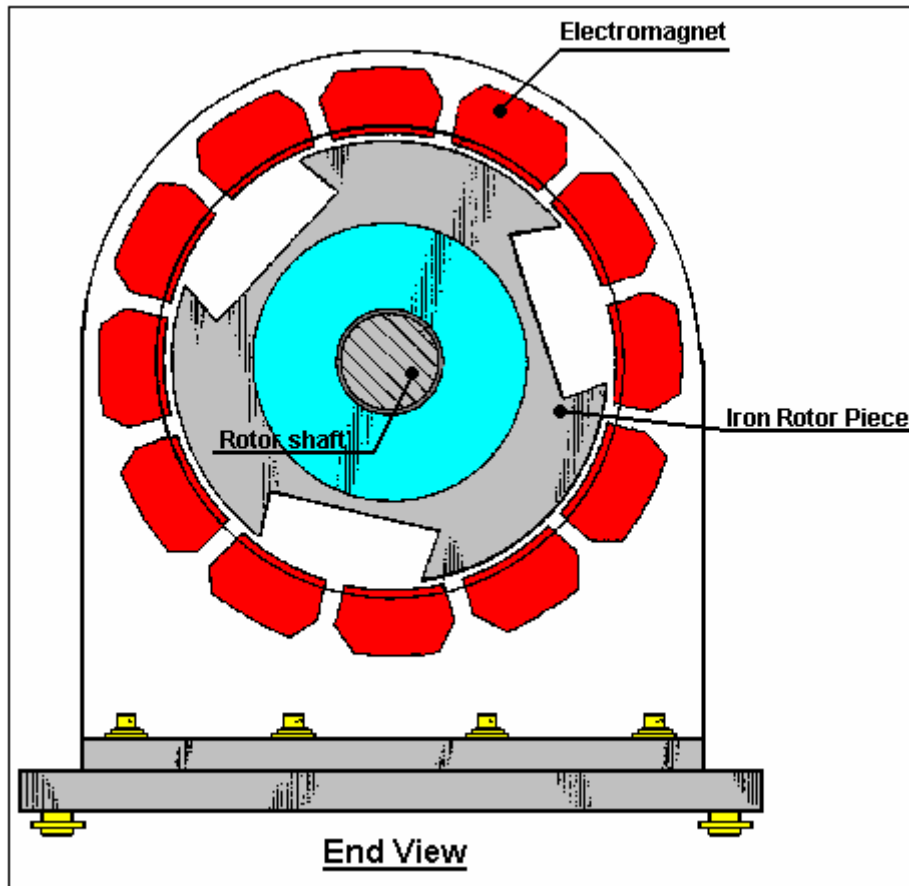

In this motor, a series of electromagnets are placed in a ring to form the active stator. The rotor shaft has two iron discs mounted on it. These discs have permanent magnets bolted to them and they have wide slots cut in them to alter their magnetic effect. The electromagnets are pulsed with the pulsing controlled via an optical disc arrangement mounted on the shaft. The result is a very efficient electric motor whose output has been measured as being in excess of its input.

James Hardy's Self-Powered Water-Pump Generator.

There is a video on Google which shows an interesting self-powered water-pump driven, electrical generator at: http://www.youtube.com/watch?v=IGpXA6qhH_Q

This is a very simple device where the jet of water from the pump is directed at a simple water-wheel which in turn, spins an electrical alternator, powering both the pump and an electric light bulb, demonstrating free-energy.



Initially, the generator is got up to speed, driven by the mains electrical supply. Then, when it is running normally, the mains connection is removed and the motor/generator sustains itself and is also able to power at least one light bulb. The generator output is normal mains current from a standard off-the-shelf alternator.

James has Patent Application US 2007/0018461 A1 published in 2007 on his design. In that application he points out that a major advantage of his design is the low noise level produced when the generator is running. In the video and the pictures above, the demonstration has the housing opened up in order to show how the generator system works, but during normal use, the compartments are completely sealed.

In his document, James shows the overall system like this:

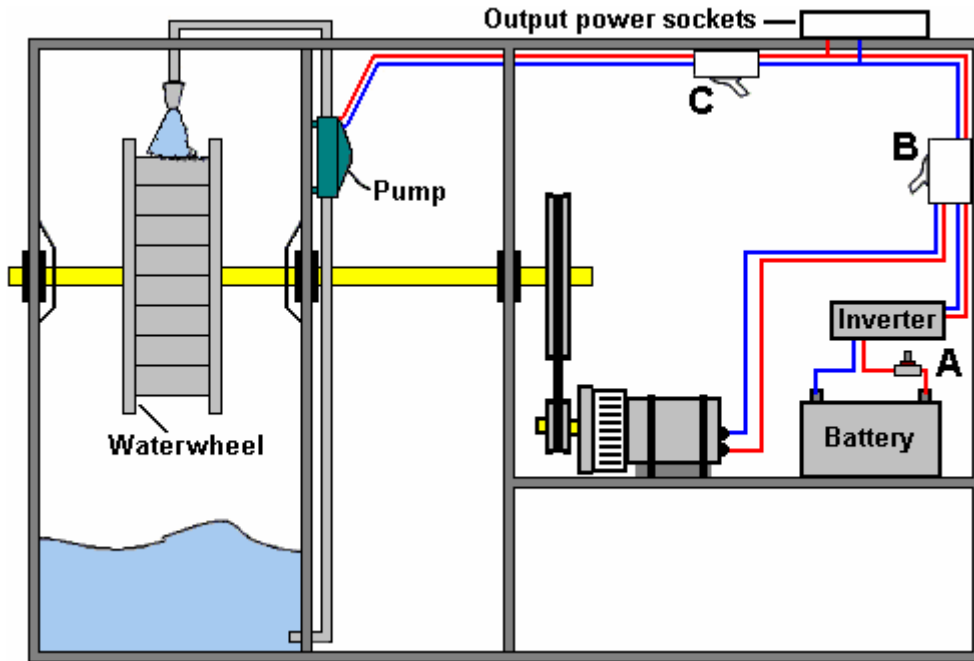

The housing is divided into three separate compartments. The first compartment has a strong axle shaft running through it, supported on ball or roller bearings – possibly ceramic for this environment. The bearings are protected by being covered by splash guards which keep the water (or other liquid) off them. A waterwheel of almost any type is mounted on the shaft and a high-capacity water pump directs a stream of liquid on to the waterwheel, striking the paddles at right angles in order to provide the maximum impact.

This first compartment is sealed in order to contain all of the liquid inside it and the bottom is effectively a sump for the liquid. A pipe located near the bottom of the compartment feeds the liquid to the pump which is located in the second compartment. The pump boosts the liquid through a nozzle, directing it at the waterwheel. While almost any nozzle will work, it is usual to choose one which produces a concentrated jet of liquid in order to generate the largest possible impact. One would expect that the larger the diameter of the waterwheel, the more powerful the system would be. However, that is not necessarily the case as other factors such as the overall weight of the rotating members might affect the performance. Experimentation should show the most effective combination for any given pump.

The rotating shaft is given a third bearing supported by the side of the final compartment. The shaft then has a large diameter belt pulley mounted on it, the belt driving a much smaller pulley mounted on the shaft of the generator. This raises the rate at which the generator shaft is rotated. If the pump operates on AC mains voltage, then the generator will be one which generates mains voltage AC. If the pump operates on, say, 12 volts, then the generator will be one which generates 12 volts DC. The diagram above, shows the arrangement for a mains voltage system as that is probably the most convenient. If a 12-volt system is chosen, then the inverter can be omitted.

The generator is started by pressing the 'normally open' press-button switch marked "A" in the diagram. This passes the battery power through to the 1-kilowatt inverter which then generates AC mains voltage. The switch marked "B" is a "changeover" switch, and for starting, it is set so that it passes the AC power through switch "A" to the pump. This causes the pump to turn on and direct a powerful jet of liquid at the waterwheel, forcing it around and so powering the generator. When the generator gets up to full speed, switch "B" is flipped over, disconnecting the inverter and feeding the generator power through to the pump, keeping it running and supplying additional power to the output power sockets mounted on top of the housing. The press-button switch is released, disconnecting the battery which is no longer needed. Switch "C" is an ordinary On/Off mains switch which is needed if you want to turn the generator off.

A major advantage of this generator system is that the main components can be bought ready-made and so only very simple constructional skills and readily available materials are needed. Another advantage is that what is happening can be seen. If the pump is not working, then it is a simple task to discover why. If the generator is not spinning, then you can see that and sort the problem. Every component is simple and straightforward.

James suggests that a suitable pump is the 10,000 gallons per hour "Torpedo Pump" from Cal Pump, web site: http://www.calpumpstore.com/products/productdetail/part_number=T10000/416.0.1.1:



Georges Mourier's COP=10,000 Motor/Generator Patent.

This patent from Frenchman Georges Mourier is quite remarkable in that it states clearly in the patent that it has a Coefficient Of Performance of 10,000 with an input power of just 10 watts producing an output of 100 kilowatts, which, considering the massive opposition of the US Patent Office to any claim of output power being greater than the input needed to produce that output, is little short of amazing. This patent contains a fair amount of mathematics where Georges goes about showing why there is a power amplification. This can be ignored by most people as the point to concentrate on is how to build a power-amplifying motor/generator.

US Patent 4,189,654

19th February 1980

Inventor: Georges Mourier

Electrical machine operating as a generator or as an amplifier

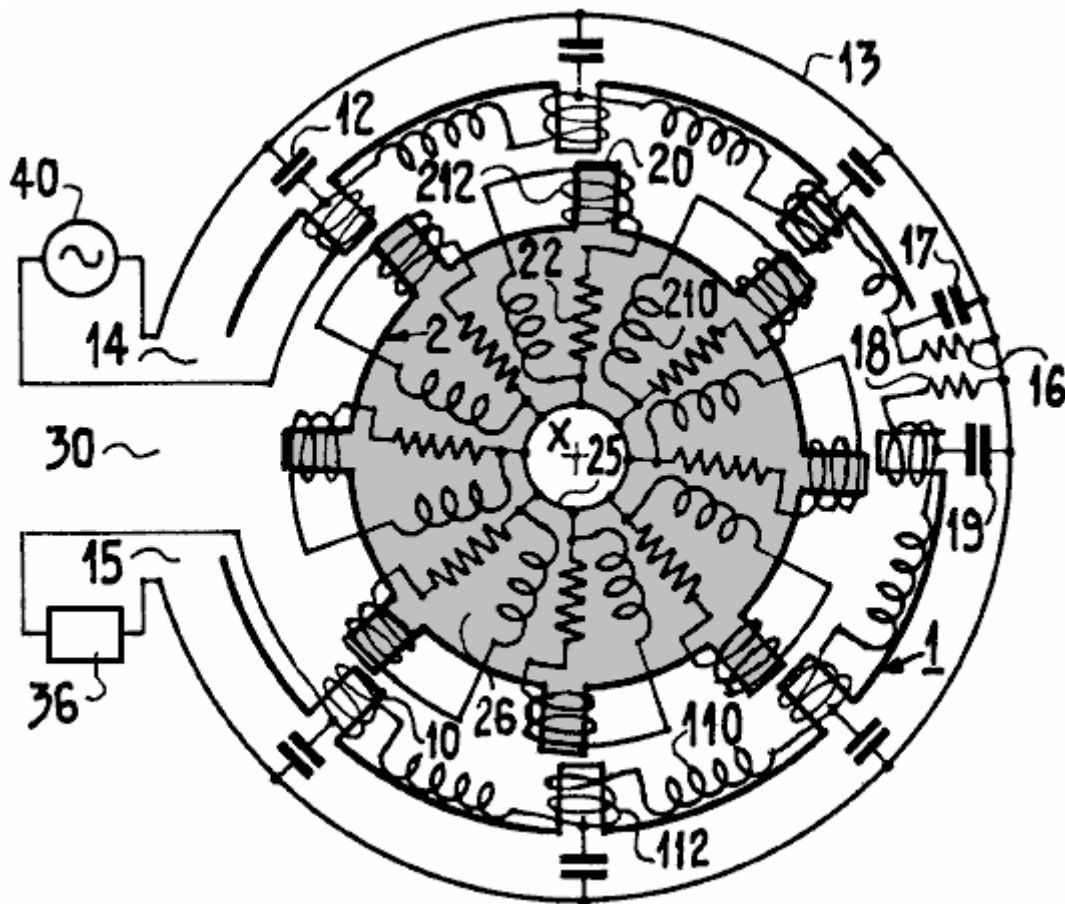

Abstract

The invention relates to an electrical machine. The stator 1 is a delay line, in the form of a low-pass filter in the example, formed by inductance 11 and capacitors 12 connected between these inductances and the common conductor 13. The rotor 2 comprises dissipating elements 22 incorporated in circuits 26, separate in the example,

and having a common point **25**. It is put in movement by a motor. The machine operates as a high-gain amplifier having a wide band of high-frequency signals applied to the input **14** of the stator, separated from the output **15** by the decoupling zone **30**. High powers are obtainable. Application to installations for testing vibration of industrial equipment and to high-power long wave radio transmission.

Description

The invention relates to an electrical machine capable of operating as a generator and as an amplifier. The machine comprises a fixed part, or stator, in which moves a moving part designated hereinafter by the term "rotor", by analogy with the case of machines of the prior art in which the movement in question is a movement of rotation, although this movement may be other than a rotation and in particular a rectilinear translation in the case of the invention.

The stator consists of a line having two conductors which have two input terminals and two output terminals; it's rotor comprises resistive elements under conditions which will be described in detail later.

In operation, a wave is propagated between the input terminals and the output terminals in question in this line. Electrical machines are known from U.S. Patent 3,875,484, in which the stator comprises inductances and capacitances incorporated in a transmission line, as in the machines of this invention, along which there is propagated, in operation, an electric wave, but contrary to the case of the invention, this line has only one pair of terminals to which those of the alternating current source are connected. The application of the voltage of this source between these terminals causes the rotation of the rotor of the machine which, as it is operating as a motor, does not have an output. Owing to the structure, a brief indication of which has been given above, the machine of this invention is intended, on the contrary, to operate as a generator or as an amplifier; it has an output constituted by the other pair of terminals of the stator, the rotor being driven by an exterior motor.

A better understanding of the invention will be had from the ensuing description with reference to the accompanying Figures which represent:

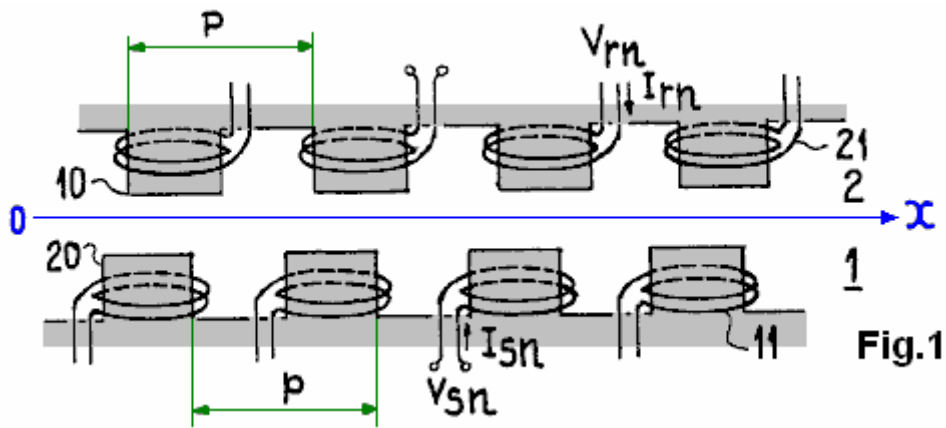
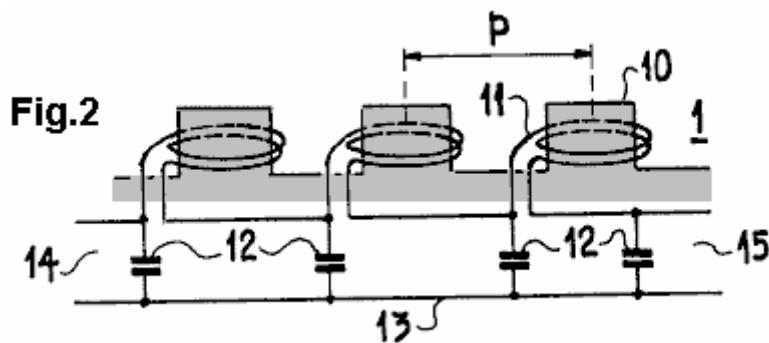

FIG.1, diagrammatically, the stator assembly and the rotor of a machine to which the invention is applied;



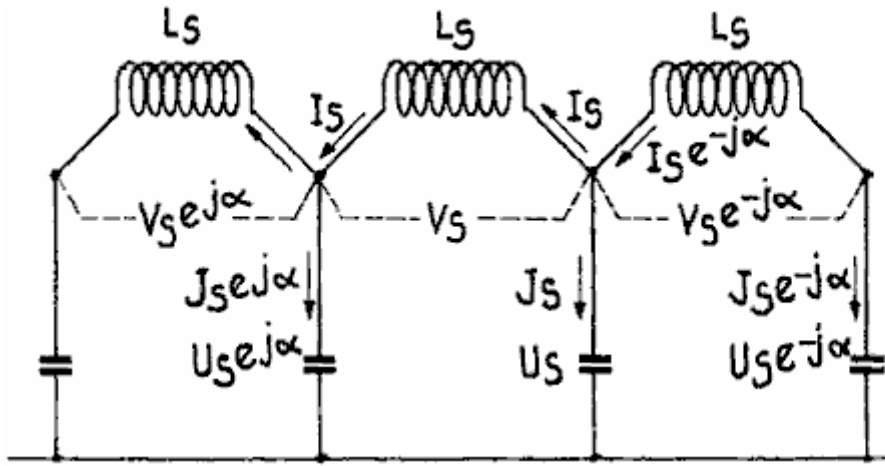

Fig.3

Fig.2 and Fig.3, diagrammatically, an embodiment of an electrical circuit of the stator of a machine of the invention and the corresponding diagram;

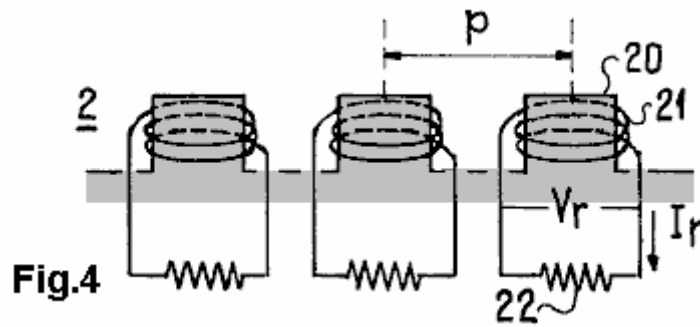

Fig.4

Fig.4, diagrammatically, a rotor structure of the machines of the invention;

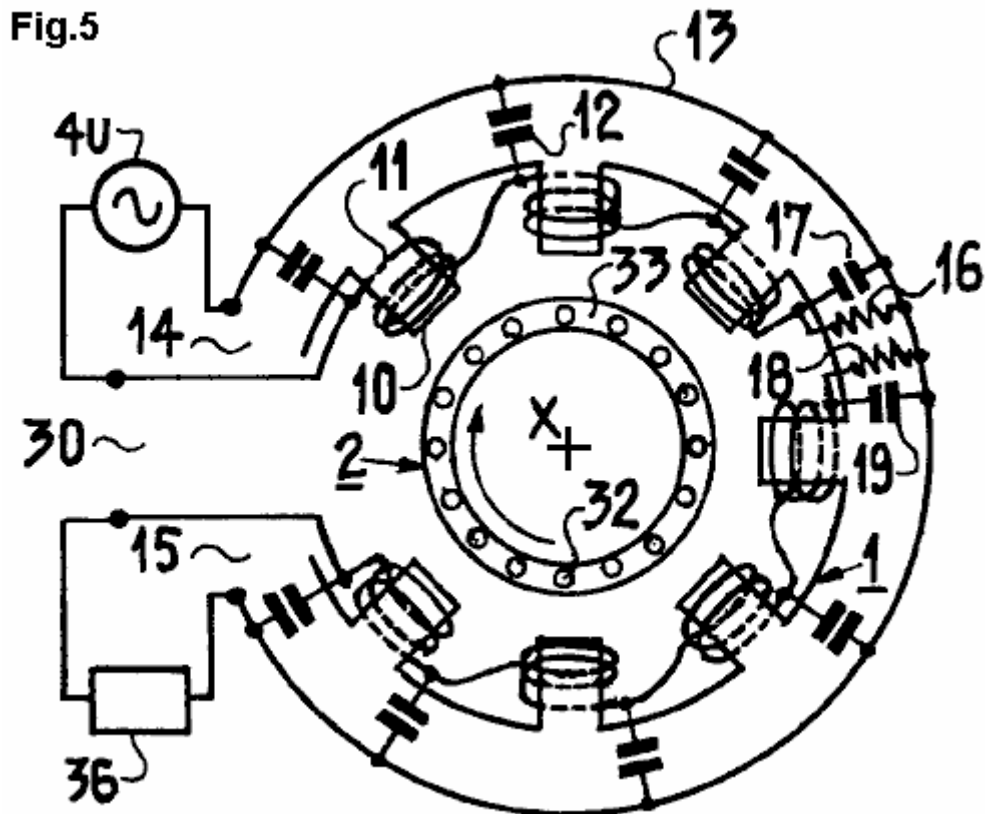

Fig.5

Fig.5, a diagrammatic view of a variant embodiment of the machine of the invention having a stator according to the design of **Fig.2**;

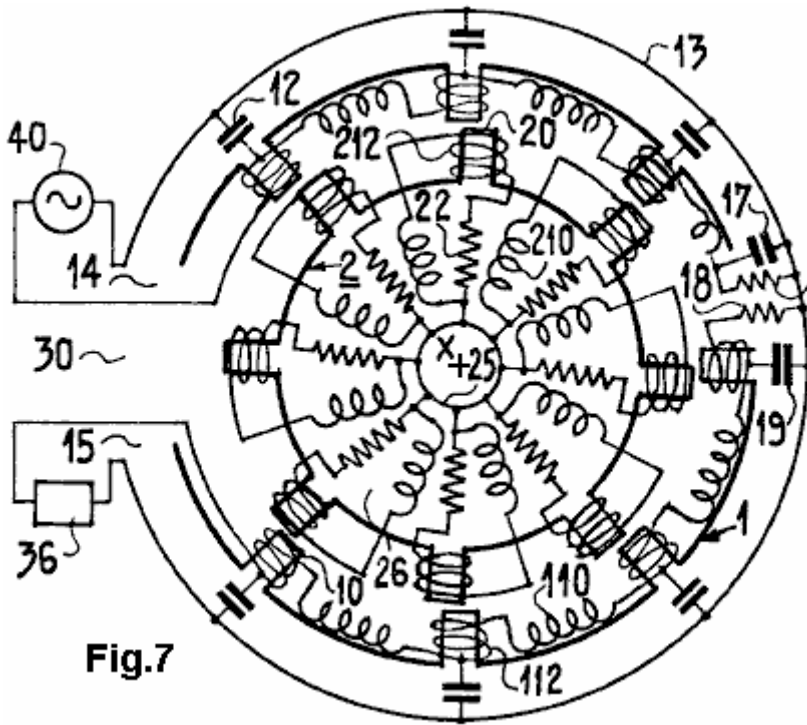

Fig.7

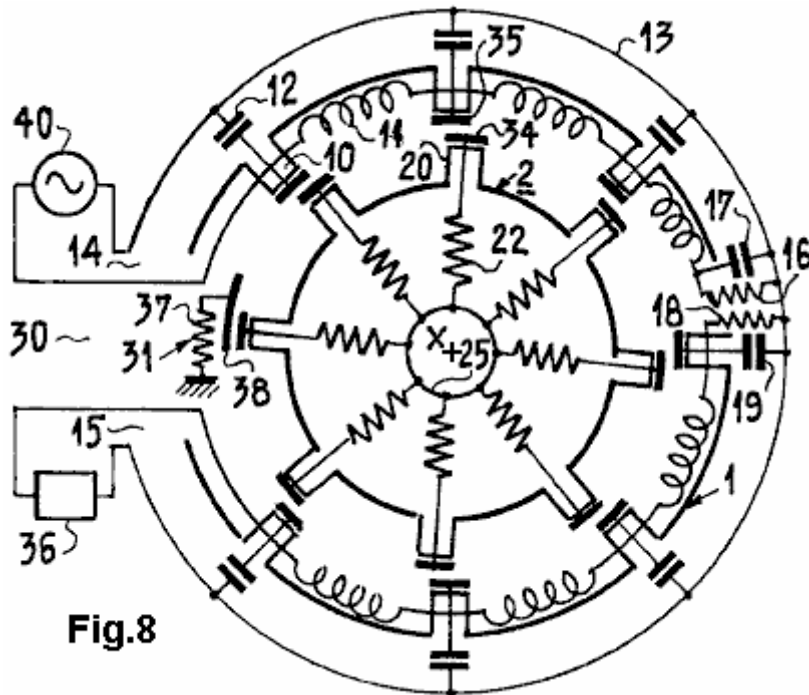

Fig.8

Fig.7 and **Fig.8**, diagrammatic views of two variant embodiments of the machine of the invention operating as amplifiers;

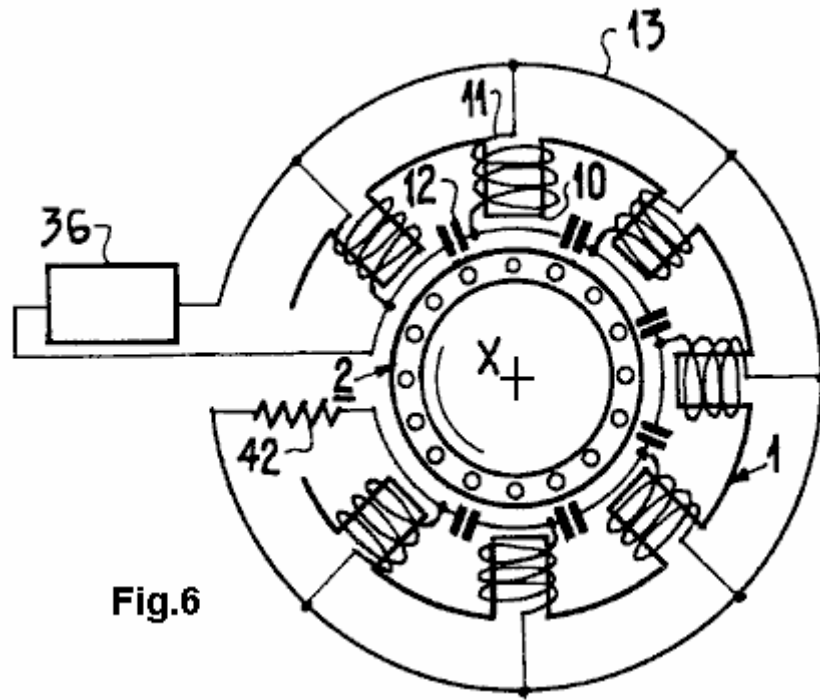

Fig.6

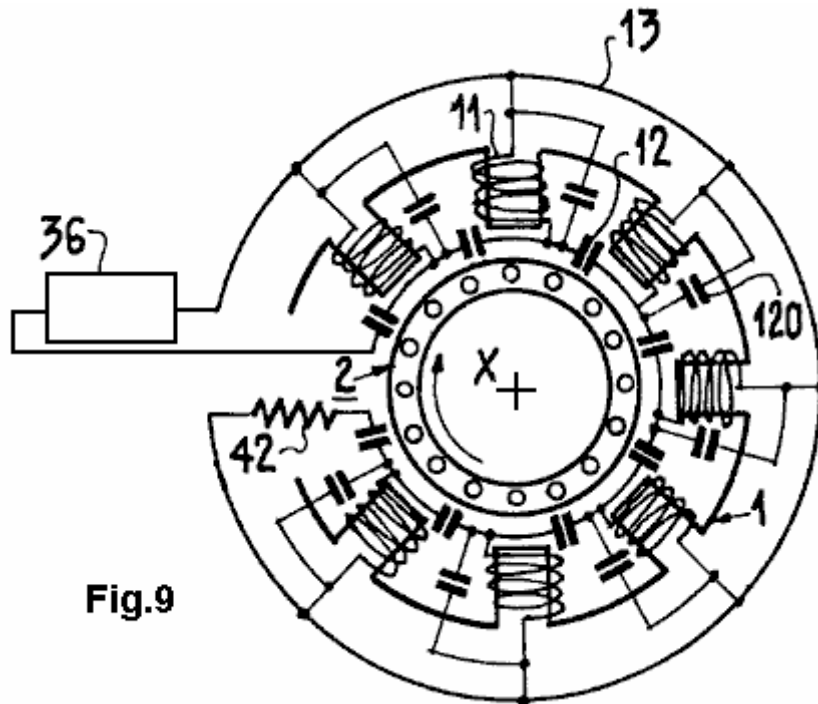

Fig.9

Fig.6 and Fig.9, two modifications of the machine of the invention operating as generators.

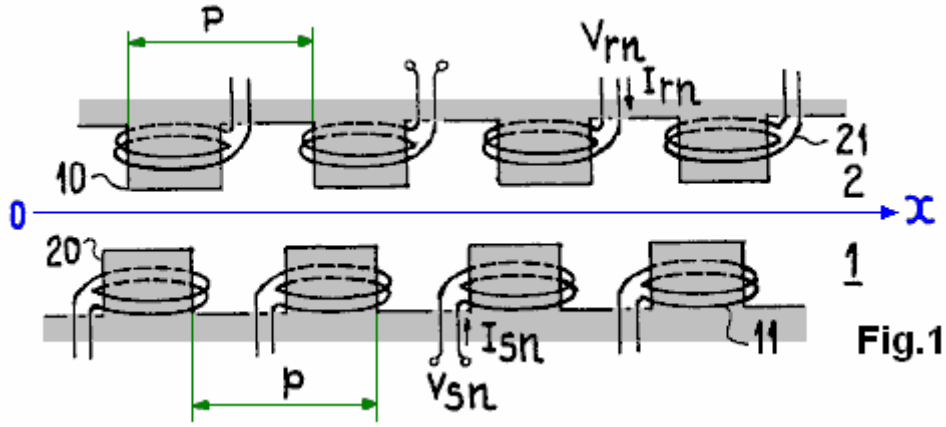

Fig.1

Fig.1 shows diagrammatically, a machine structure to which the invention is applied, in which the stator 1 and the rotor 2 comprise poles aligned in the direction $o \rightarrow x$ along which the rotor movement occurs. These poles are marked as 10 and 20 and are repeated with the same horizontal spacing or pitch p in both the rotor and the stator. References 11 and 21 are the inductive windings through which the coupling occurs between a pole of the rotor and a pole of the stator when they align in the course of their movement.

V_{sn} and V_{rn} are the instantaneous values of the voltages at the ends of these windings, and I_{sn} and I_{rn} are the currents in those coils at the moment of this alignment, n being the number assigned to the pole in each part of the machine. In order to simplify the notations, this index number 'n' will be omitted when mentioning the voltages and currents in question. ϕ designates the magnetic flux and M the coefficient of mutual inductances of this coupling. There are then obtained the following known equations:

$$\begin{aligned} \phi_s &= L_s I_s + M I_r \dots\dots\dots (1) \\ \phi_r &= M I_s + L_r I_r \dots\dots\dots (2) \\ V_s &= j\omega L_s I_s + j\omega M I_r \dots\dots\dots (3) \\ V_r &= j\omega' M I_s + j\omega' L_r I_r \dots\dots\dots (4) \end{aligned}$$

where L_s and L_r are the values of inductances 11 and 21 and ϕ_s and ϕ_r the magnetic flux in these windings.

In these equations, the quantities ω and ω' are the angular frequencies of the currents in the stator and the rotor respectively; $\omega = 2\pi f$, where f is the corresponding frequency. For equal phase differences between two successive poles of the stator and rotor, the pulses ω and ω' in the relation:

$$\omega' = \omega - \beta u \dots\dots\dots (5)$$

where β is in accordance with the usual definition the constant of propagation of the magnetic field wave along the stator, and u is the speed at which the rotor moves in front of the stator in the direction of the reference axis $o - x$ in the case of the machine of the embodiment of Fig.1.

$$\beta = \frac{2\pi}{\Lambda} = \frac{\omega}{v_\phi}$$

if Λ and v_ϕ respectively are the wavelength and the phase velocity in the stator.

In the embodiment of the machine of this invention having a stator in the form of a low-pass filter transmission line with an input 14 and an output 15, and the inductances 11, charge-accumulating elements 12 mounted between these inductances, and a common conductor 13 as shown in Fig.2 and Fig.3, there is added to the foregoing equations the following equation:

$$\frac{V_s}{I_s} = - \frac{2}{jC_s\omega} (1 - \cos \alpha) \dots\dots\dots (6)$$

where α is equal to βp and C_s is the value of the capacitors 12 (Fig.2) included in the construction of the filter, it being observed that there is obtained with the notations of Fig.3:

$$I_s = \frac{-J_s}{1 - \exp(-j\alpha)} \quad \text{and} \quad V_s = U_s (1 - \exp(j\alpha)), \quad \text{with} \quad U_s = -j \frac{J_s}{C_s\omega}$$

There is also added:

$$V_r + R_r I_r = 0 \dots \dots \dots (7)$$

the equation for a rotor constructed, as shown in Fig.4, by separate resistive circuits each of which comprises, in addition to the foregoing, coupling inductance 21, a resistor 22 of value R_r.

By eliminating the magnitudes of flux, voltage and current between the homogeneous equations (1), (2), (3), (4), (6) and (7) and by replacing ω' with its expression taken from equation (5), there is obtained an equation in β whose roots have an imaginary part, whence it results that the variation with respect to time of the wave propagated along the stator in the direction o --- x of Fig.1, whose amplitude is proportional, in accordance with the conventional notation, to exp j(ωt-βx), undergoes an amplification in the course of this propagation.

The equation in question is:

$$\left(\beta - \frac{\omega}{u} + \frac{j}{u} \frac{L_r}{R_r}\right) (\beta^2 - \beta^2_{21}) = j \frac{\beta^2_{21}}{u} \frac{L_r}{R_r} \frac{\frac{M^2}{L_r L_s}}{1 - \frac{M^2}{L_r L_s}} \dots \dots \dots (8)$$

with $\beta^2_{21} = \omega^2 C_s L_s \frac{1}{p^2} \left(1 - \frac{M^2}{L_r L_s}\right)$

and assuming that α is small, that is to say, that the machine has a large number of phases in the electro-technical sense of the word, the roots of which will be calculated by their relative difference z from a reference value chosen to be equal to ω / u, which is but little different, under the conditions of operation of the machines of the invention, from the quantity β₁ defined above; there is obtained:

$$z = \frac{\beta - \beta_1}{\beta_1} \text{ and } \beta = \beta_1(1 + z) \dots \dots \dots (9)$$

The foregoing ratio ω/u is none other than the value of β in synchronous machines, in which ω' is null (equation 5). In the machines of this invention, ω' is non-zero: these machines operate in the asynchronous manner.

The equation in z is written:

$$z^2 + 2j\gamma z - j\gamma = 0 \dots \dots \dots (8')$$

in the particular case of a coupling coefficient

$$\mu = \frac{M^2}{L_r L_s} \text{ de } \frac{1}{2}$$

It has two roots having an imaginary part. The machine is capable of amplifying a signal applied to the input of the stator. The order of magnitude of this amplification is shown below as an example. The expression of these roots is:

$$z_{\pm} = -j\gamma \pm j\sqrt{\gamma^2 - j\gamma} \dots \dots \dots (10)$$

with:

$$z_{\pm} = \frac{R_r}{L_r} \frac{1}{2u\beta_1}$$

to which the following numerical values correspond for a certain number of values of γ. The amplified wave corresponds to the root Z₊.

	0.01	0.03	0.1	0.3	1
Z ₊	0.0703 + 0.610	0.120 + 0.094j	0.212 + 0.135j	0.334 + 0.149j	0.455 + 0.098j

The gain "g" in power per unit length of the stator is, according to equation (9) is:

$$g \text{ db/m} = 8.7\beta_1 - (\text{imaginary part of } z)$$

In the given example, this gain reaches its maximum value for the wave corresponding to z_+ , for γ between 0.1 and 0.3. The imaginary part of z is then in the neighbourhood of 0.15, which gives for g , in respect of a stator whose length is 5 wavelengths ($x = 5$), about 40 decibels. It will be observed that the corresponding propagation constant β differs only slightly in absolute value from the constant ω/u corresponding to synchronous operation. The machine of this invention operates under conditions which differ only slightly from synchronous operating conditions.

The wave passing through the stator is amplified in the manner of an electromagnetic wave which is propagated along the delay line of wave propagating tubes employed in hyper frequency described, among others, by J. R. Pierce in "Travelling Wave Tubes", Van Nostrand Co, 1950. The amplification occurs, as for these tubes, in a wide band around the central frequency.

In the foregoing, the rotor has been represented, for ease of description, with a structure having poles (reference 20 in the Figures). With the scope of the invention the rotor could be in the form of the well-known squirrel-cage structure of asynchronous machines. The above calculations remain valid in giving to the notion of resistance and to the notion of inductance the signification they have in this case.

The foregoing properties have been established by means of simplifying hypotheses which permit a clearer presentation. These properties apply generally to all machines whose stator and rotor would have the indicated electrical structure, even in the case of an operation which would differ slightly from these hypotheses in the neighbourhood of synchronous frequency. Moreover, the case was considered of a coupling by inductance between the rotor and the stator with a mutual coefficient M . Within the scope of the invention, this coupling could also be of an electrostatic nature between the conductors of the stator and rotor; similar equations would be obtained by substituting for the coefficient M the coefficient of electrostatic influence between the conductors in question, for the quantity L_r that, C_r , of the capacitance of each circuit of the rotor and, after interversion between L_s and C_s . In this case V_r (equation 7) represents the voltage drop at the terminals of the capacitance of the rotor. The machine of this invention is also capable of operating as a generator, as will be seen below. A few embodiments of the structure of the machine of this invention will be given here.

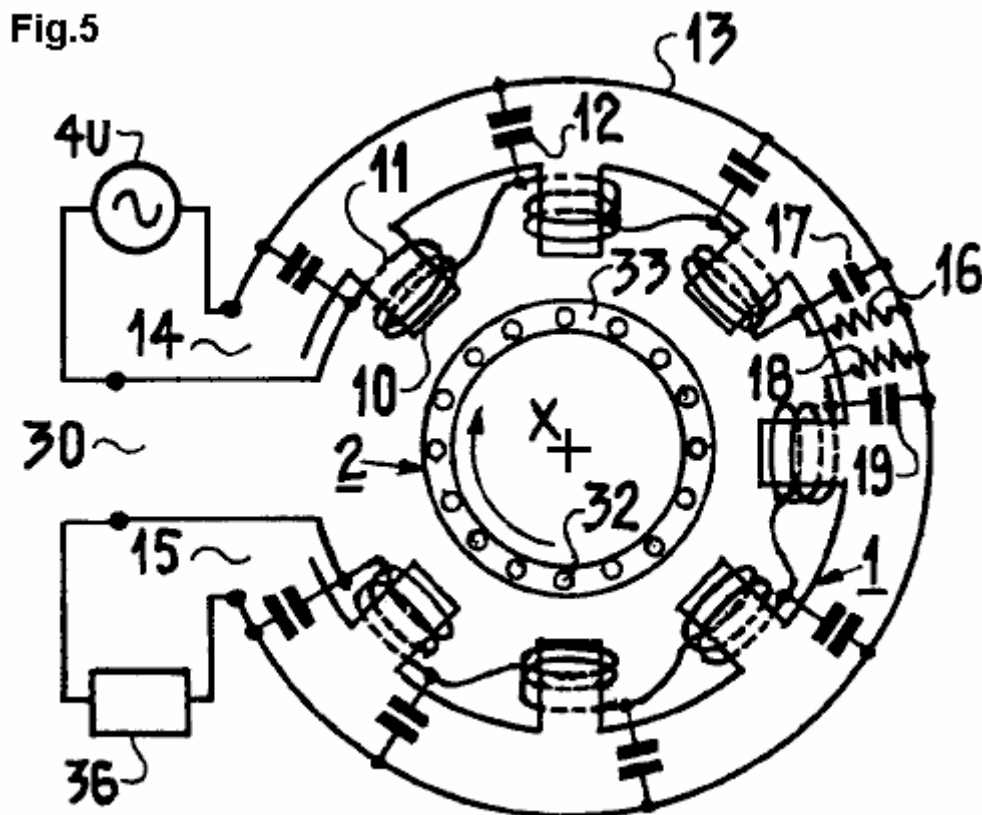

Fig.5 shows a first modification of this structure comprising a stator in accordance with the low-pass filter diagram of **Fig.2**. The rotor is a squirrel-cage, the reference numerals 32 and 33 are the bars and the end faces. In operation, it is driven by a rotor (not shown) which rotates it in the direction of the arrow about axis X which is common to the rotor and the stator of the machine. A source of alternating voltage 40 is applied to input 14 of the

stator, and applied to the output **15** is a load **36**, the impedance of which is equal to the characteristic impedance of the line of which the stator is part. In this arrangement of revolution about the axis **X**, a decoupling zone **30** separates the input and output of the stator. Further, in this zone, and in order to avoid any risk of coupling between input and output of the stator by the circuits of the rotor, there is provided any damping device considered necessary, an embodiment of which is given below.

The different elements of the filter constituting the stator are damped by the resistors **16**, and **18** which are connected as shown in the Figure between the windings **11** and the conductor **13** common to the terminals of the capacitors **17** and **19**.

Such a machine operates as an amplifier of the signal applied to the input of the stator with a gain which is of the order of 40 db in the numerical example given above. Such machines may be used as supply sources for high-power vibrators for the testing of industrial equipment of all kinds. They have the advantage over presently-known installations of this type of avoiding the steep leading edges and the high frequencies which result in their spectrum. Output powers of 100 kilowatts may be obtained with 10 watts applied at the input, with frequencies ranging up to 50 kHz. The same machine may be used as a high-power amplifier in radio broadcasting.

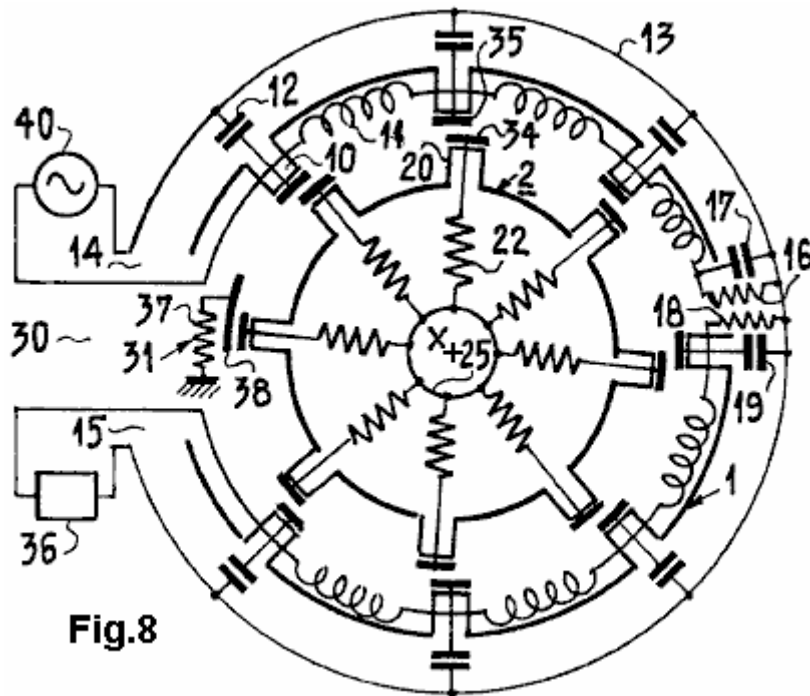

Fig.8

Fig.7 and **Fig.8** give two other modifications of the arrangement of the circuits of the rotor in which the same reference numbers indicate the same components as in the preceding Figures. In **Fig.8**, the coupling between the rotor and stator is electrostatic. It occurs between conductors **34** and **35** when they face each other in the course of the rotation of the rotor.

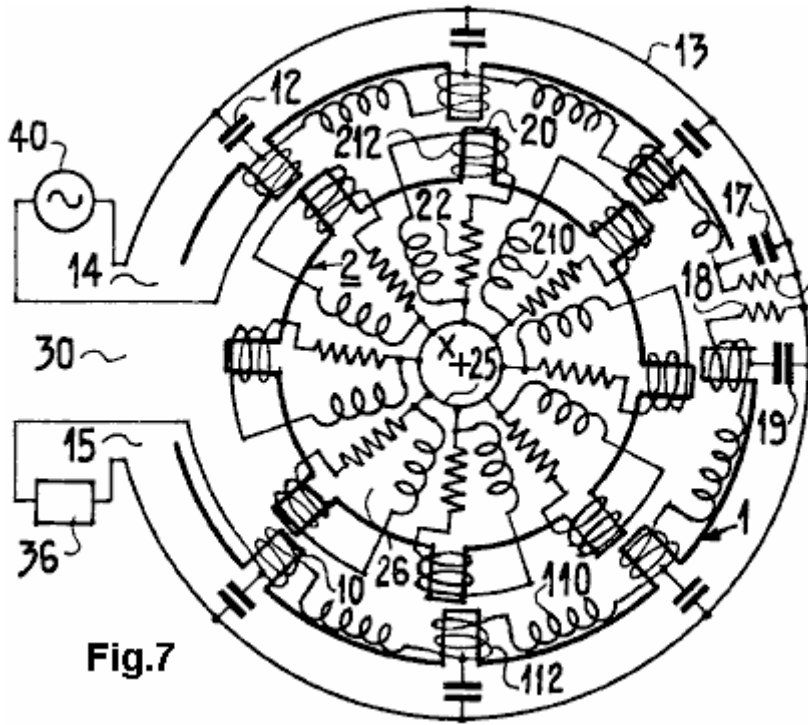

Fig.7

In **Fig.7**, 110 and 112 designate the two constituent parts of the self-inductances associated with each one of the poles 10 of the stator, and 210 and 212 the parts of the self-inductances of each pole 20 of the rotor. In both **Fig.7** and **Fig.8**, 25 is a common conductor and 26 indicates all of the elements associated with each pole of the rotor. In the modification of **Fig.8**, an example is given of the construction of the damping device 31 in the zone 30. A rail 38 is earthed through resistor 37 and through a contact (not shown) of the circuits of the rotor out along this rail 38 when they pass through the zone 30.

The same machine is capable of operating as a generator (**Fig.6** and **Fig.9**).

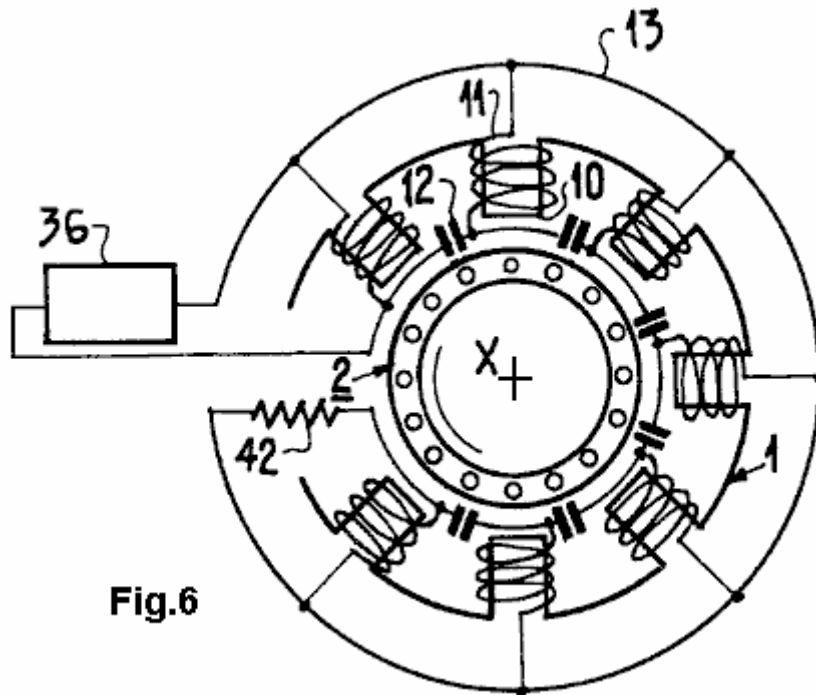

Fig.6

Fig.6 represents a machine whose stator is connected as a high-pass filter: each pole winding is connected at one end to the common conductor 13 and at the other end to two capacitors 12, as shown above. The filter thus constructed has a phase velocity which varies very rapidly with the frequency and in the direction opposed to that of the flux of electrical energy (inverse wave). The rotor has a velocity rather close to that of the phase velocity whereas the energy flows back to the load 36 in the opposite direction. The upstream side (for the energy) of the filter terminates on the characteristic impedance 42 of the filter. A generator is obtained in this way having a

frequency which is determined within a wide band by the speed of rotation of the rotor. In the example shown in the Figure, the rotor has a squirrel-cage structure.

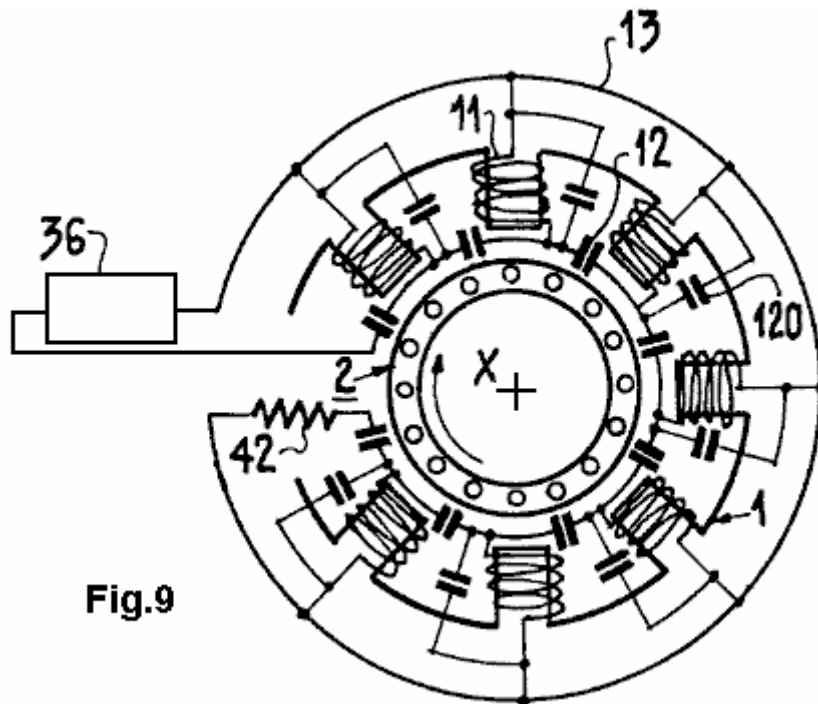

Fig.9

The machine of **Fig.9** differs from that of **Fig.6** by the addition of supplementary capacitors **120** arranged in parallel with the inductances **11**. The circuit thus obtained is an inverse wave band-pass filter. The width of its band-pass is determined by the respective values of the capacitors **12** and **120**. The phase velocity remains rapidly variable as a function of the frequency. The machine operates as a generator, the frequency of which, depends only very slightly on the velocity of rotation of the rotor.

The “RotoVerter” Power Amplification System.

Not all pulsed-drive systems use permanent magnets as part of their drive mechanism. For example, the RotoVerter, designed by Hector D Peres Torres of Puerto Rico, and which has been reproduced by several independent researchers, producing at least 10 times more output power than the input power, uses standard three-phase electric motors instead of magnets.

This system has been reproduced by several independent researchers and it produces a substantial power gain when driving devices which need an electrical motor to operate. At this time, the web site: <http://panacea-bocaf.org/rotoverter.htm> has considerable details on how to construct the device as do the <http://www.scribd.com/doc/2965018/HighEfficiencyForElectricMotors> and the <http://www.scribd.com/doc/26347817/RV-Energy-Saving-X> documents. The outline details are as follows:

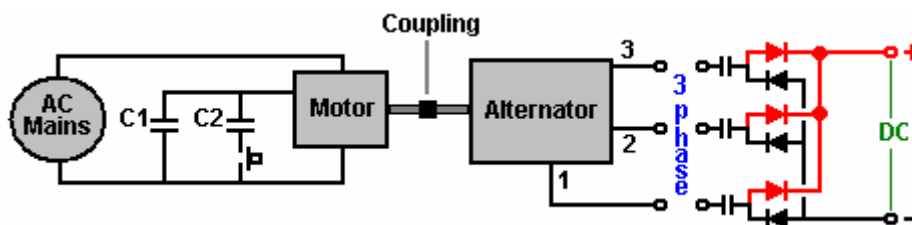

The output device is an alternator which is driven by a three-phase mains-powered, 3 HP to 7.5 HP motor (both of these devices can be standard ‘asynchronous squirrel-cage’ motors). The drive motor is operated in a highly non-standard manner. It is a 240V motor with six windings as shown below. These windings are connected in series to make an arrangement which should require 480 volts to drive it, but instead, it is fed with 120 volts of single-phase AC. The input voltage for the motor, should always be a quarter of its rated operational voltage. A virtual third phase is created by using a capacitor which creates a 90-degree phase-shift between the applied voltage and the current.

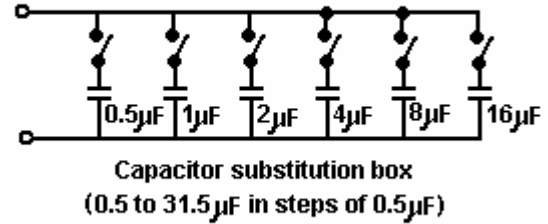
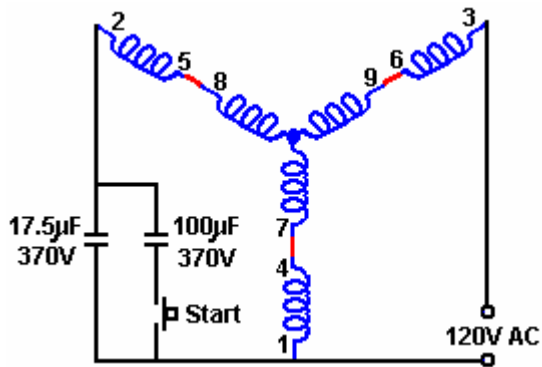

The objective is to tune the motor windings to give resonant operation. A start-up capacitor is connected into the circuit using the press-button switch shown, to get the motor up to speed, at which point the switch is released, allowing the motor to run with a much smaller capacitor in place. Although the running capacitor is shown as a fixed value, in practice, that capacitor needs to be adjusted while the motor is running, to give resonant operation. For this, a bank of capacitors is usually constructed, each capacitor having its own ON/OFF switch, so that different combinations of switch closures give a wide range of different overall values of capacitance. With the six capacitors shown above, any value from 0.5 microfarad to 31.5 microfarad can be rapidly switched to find the correct resonant value. These values allow combined values of 0.5, 1.0, 1.5, 2.0, 2.5, 3.0, 3.5,by selecting the appropriate switches to be ON or OFF. Should you need a value greater than this, then wire a 32 microfarad capacitor in place and connect the substitution box across it to test higher values step by step to find the optimum value of capacitor to use. The capacitors need to be powerful, oil-filled units with a high voltage rating - in other words, large, heavy and expensive. The power being handled in one of these systems is large and setting one up is not without a certain degree of physical danger. These systems have been set to be self-powered but this is not recommended, presumably because of the possibility of runaway with the output power building up rapidly and boosting the input power until the motor burns out.

The Yahoo EVGRAY Group at <http://groups.yahoo.com/group/EVGRAY> has a large number of members many of whom are very willing to offer advice and assistance. A unique jargon has built up on this forum, where the motor is not called a motor but is referred to as a "Prime Mover" or "PM" for short, which can cause confusion as "PM" usually stands for "Permanent Magnet". RotoVerter is abbreviated to "RV" while "DCPMRV" stands for "Direct Current Permanent Magnet RotoVerter" and "trafo" is a non-standard abbreviation for "transformer". Some of the postings in this Group may be difficult to understand due to their highly technical nature and the extensive use of abbreviations, but help is always available there.

To move to some more practical construction details for this system. The motor (and alternator) considered to be the best for this application is the "Baldor EM3770T" 7.5 horsepower unit. The specification number is 07H002X790, and it is a 230/460 volts 60Hz 3-phase, 19/9.5 amp, 1770 rpm, power factor 81, device.

The Baldor web site is www.baldor.com and the following details should be considered carefully before trying any adaption of an expensive motor. The following constructional photographs are presented here by kind permission of Ashweth of the EVGRAY Group.

The end plate of the drive motor needs to be removed and the rotor lifted out. Considerable care is needed when doing this as the rotor is heavy and it must **not** be dragged across the stator windings as doing that would damage them.



The second end-plate is then removed and placed on the opposite end of the stator housing:



The fan is removed as it is not needed and just causes unnecessary drag, and the rotor is inserted the opposite way round to the way it was removed. That is, the housing is now the other way round relative to the rotor, since the rotor has been turned through 180 degrees before being replaced. The same part of the shaft of the rotor passes through the same end plate as before as the end plates have also been swapped over. The end plates are bolted in position and the rotor shaft spun to confirm that it still rotates as freely as before.

To reduce friction to an absolute minimum, the motor bearings need to be cleaned to an exceptional level. There are various ways of doing this. One of the best is to use a carburettor cleaner spray from your local car accessories shop. Spray inside the bearings to wash out all of the packed grease. The spray evaporates if left for a few minutes. Repeat this until the shaft spins perfectly, then put one (and only one) drop of light oil on each bearing and do not use WD40 as it leaves a residue film. The result should be a shaft which spins absolutely perfectly.

The next step is to connect the windings of the two units. The motor (the "Prime Mover") is wired for 480 volt operation. This is done by connecting winding terminals 4 to 7, 5 to 8 and 6 to 9 as shown below. The diagram shows 120 volts AC as being the power supply. This is because the RotoVerter design makes the motor operate at a much lower input than the motor designers intended. If this motor were operated in the standard way, a 480 volt 3-phase supply would be connected to terminals 1, 2 and 3 and there would be no capacitors in the circuit.

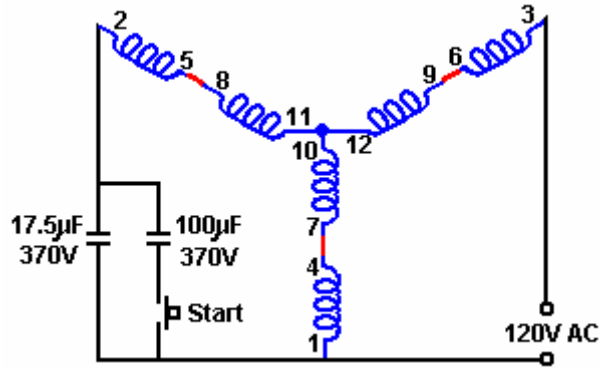

It is suggested that the jumpering of the motor windings is more neatly done by removing the junction box cover and drilling through it to carry the connections outside to external connectors, jumpered neatly to show clearly how the connections have been made for each unit, and to allow easy alterations should it be decided to change the jumpering for any reason.

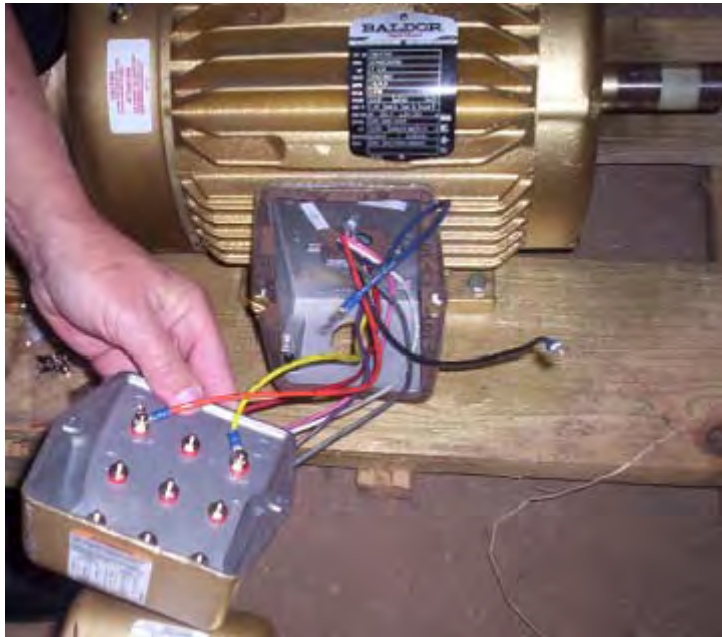

The same is done for the unit which is to be used as the alternator. To increase the allowable current draw, the unit windings are connected to give the lower voltage with the windings connected in parallel as shown below with terminals 4,5 and 6 strapped together, 1 connected to 7, 2 connected to 8 and 3 connected to 9. This gives a three-phase output on terminals 1, 2 and 3. This can be used as a 3-phase AC output or as three single-phase AC outputs, or as a DC output by wiring it as shown here:

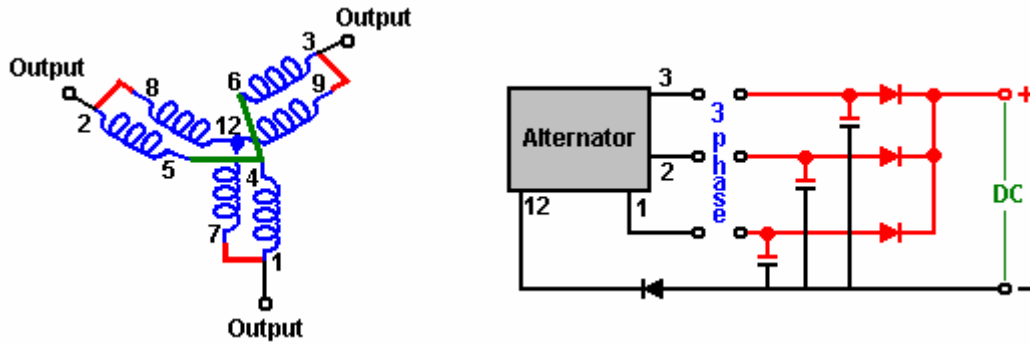

The motor and the alternator are then mounted securely in exact alignment and coupled together. The switching of the direction of the housing on the drive motor allows all of the jumpering to be on the same side of the two units when they are coupled together, facing each other:



The input drive may be from an inverter driven from a battery charged via a solar panel. The system now needs to be 'tuned' and tested. This involves finding the best 'starting' capacitor which will be switched into the circuit for a few seconds at start-up, and the best 'running' capacitor.

To summarise: This device takes a low-power 110 Volt AC input and produces a much higher-power electrical output which can be used for powering much greater loads than the input could power. The output power is much higher than the input power. This is free-energy under whatever name you like to apply to it. One advantage which should be stressed, is that very little in the way of construction is needed, and off-the-shelf motors are used. Also, no knowledge of electronics is needed, which makes this one of the easiest to construct free-energy devices available at the present time. One slight disadvantage is that the tuning of the "Prime Mover" motor depends on its loading and most loads have different levels of power requirement from time to time. A 220 Volt AC motor can also be used if that is the local supply voltage.

If an alternator is being driven by the RotoVerter motor (the "Prime Mover") but although the shaft is being rotated rapidly there is no output voltage, then it is likely that the alternator has been sitting around unused for a long time and has lost the magnetic properties which it needs at start-up. To fix this, connect each of the three output windings, one at a time, across a car battery for about five seconds to develop some magnetism and the alternator will then work. This is a one-off thing only needed after a long period of inactivity.

It is not essential to construct the RotoVerter exactly as shown above, although that is the most common form of construction. The Muller Motor mentioned earlier, can have a 35 kilowatt output when precision-constructed as Bill Muller did. One option therefore, is to use one Baldor motor jumpered as the "Prime Mover" drive motor and have it drive one or more Muller Motor style rotors to generate the output power:

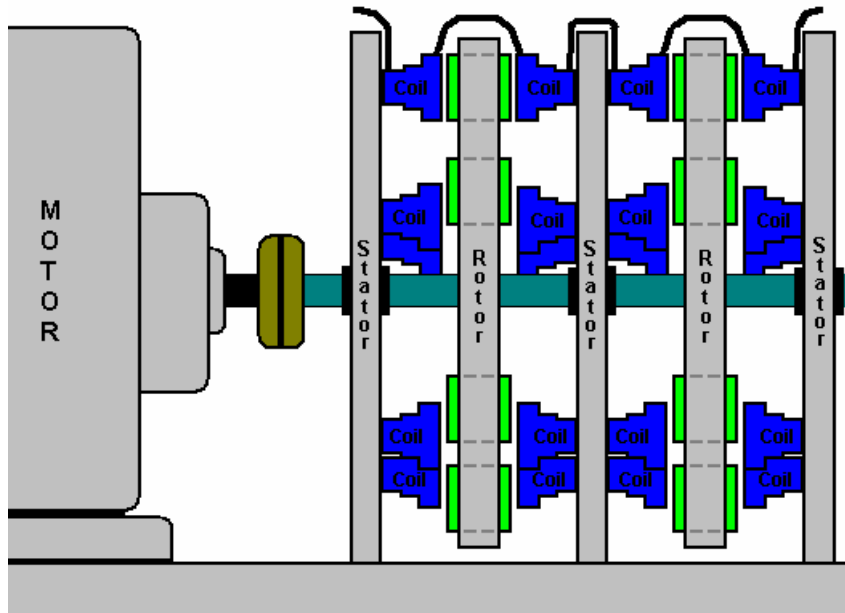

Power Boosting Through Coil Short-Circuiting.

The RotoVerter output and the Muller Motor/Generator output (and possibly, the Adams Motor output) can be increased very substantially by a technique developed by "Kone" the moderator of the EVGRAY Yahoo forum already mentioned. The technique is to place a dead short-circuit across each output coil, just as the magnetic field of that coil reaches a maximum. This is done five times in rapid succession and can boost the output power by an estimated factor of 100 times.

On the surface, it appears complete madness to place a short-circuit across the very output which you are generating as the whole point of the exercise. However, it is not as mad as it seems. At the peak point, the coil itself contains a large amount of energy and when a short-circuit is placed across it, the result is quite unusual. The effect of short-circuiting an iron-cored coil has been demonstrated by Ron Pugh of Canada with a bench test using this equipment:

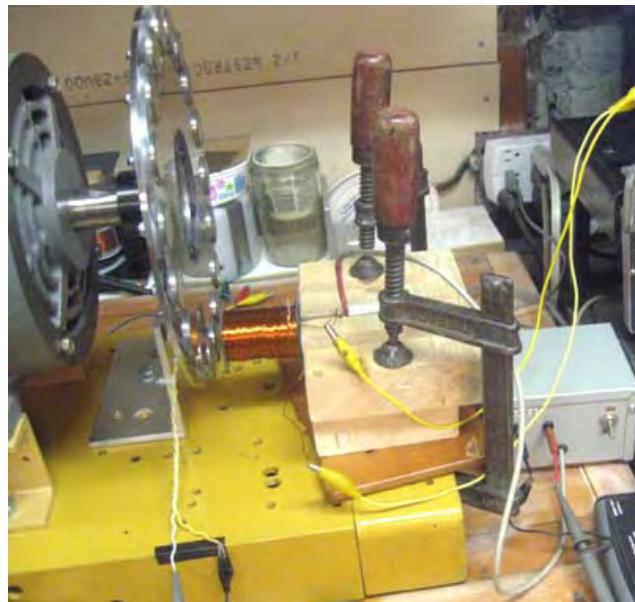

Here, a device for measuring magnetic fields is sensing the magnetic field of the coil as the rotor magnets move past the coil. The measurement is done with the coil operating normally and then again, with the coil short-circuited. The results are shown in these oscilloscope displays:

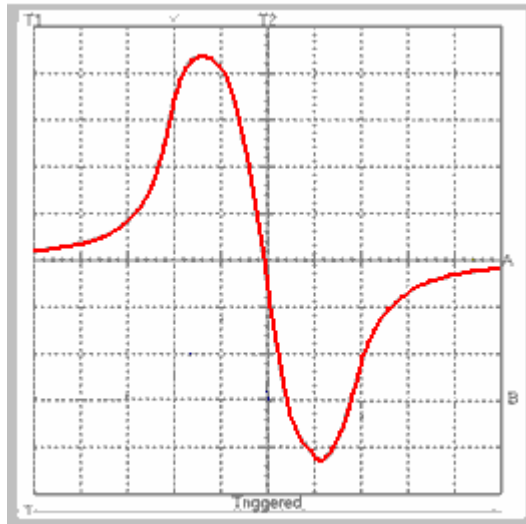

OPEN COIL

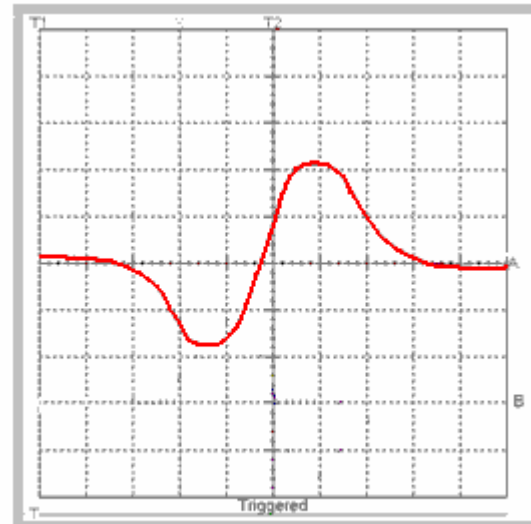

SHORT-CIRCUITED COIL

Quite surprisingly, the magnetic field is reversed by the short-circuit. If we consider just the first half of the cycle:

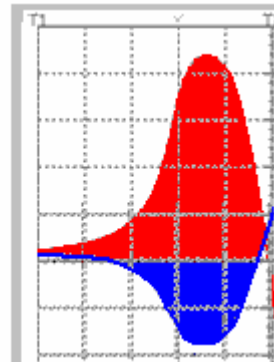
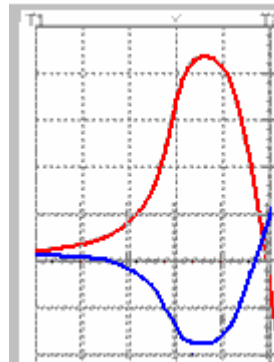

You will notice that when the open coil has a very strong positive position (relative to a North magnetic pole), the short-circuited coil has a strong reading of the opposite polarity. Therefore, at any given instance near the peak, there is the potential for a major magnetic reversal if the coil were to be switched from the red area into the blue area and back again. You might imagine that if the coil short-circuiting were performed very rapidly, that there would be a result like this:

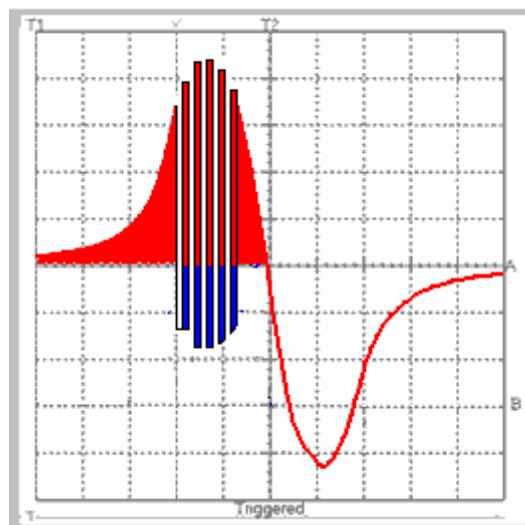

However, this is not really possible with an iron-cored coil as it is not able to reverse its magnetisation rapidly enough to produce this effect. Coils with iron cores might get up to 3,000 reversals per second although 1,000

would probably be a more realistic figure. For higher frequencies, a ferrite core could be used and for yet higher frequencies again, an iron-dust epoxy-encapsulated core is needed. For unlimited frequencies, an air-core coil is used.

In the RotoVerter / Muller Motor example where Kone has demonstrated major energy gains, the arrangement is different to Ron Pugh's bench-test example. Firstly, the magnets on the rotor present two poles to the coil as they pass by, giving a full, even sine wave output. Secondly, Kone uses an air-core coil and he has the fast switching implemented to take advantage of that coil type:

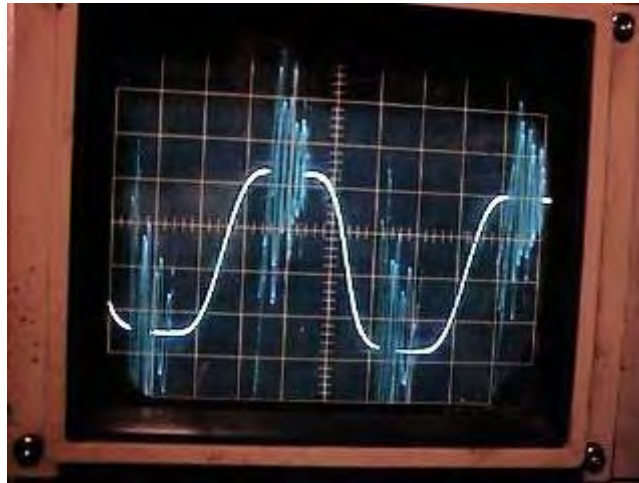

This screen shot shows exactly the same effect with the oscillating pulses plunging down to exactly where the negative trace would be at that time during each of the short-circuited periods. The display is showing a twenty-volt peak-to-peak waveform with each complete sine wave cycle taking 2 milliseconds.

Instead of the original gradual magnetic rise to a single peak, there are now five very sharp magnetic reversals, each of which are substantially larger than the original peak. It is the change of magnetic flux in the pick-up coil which produces the output power, so it can be seen that with this additional switching, a massive increase in flux change has been produced in the output coil. This increase is both a larger magnetic swing and a much greater rate of change of the flux, and as the rotor is spinning at some 1,800 rpm and has many magnets in it, the overall magnetic power increases by a major factor. Please note that in the following diagrams produced by Kone, the rotor magnet has a South pole which reaches the pick-up coil first, followed by a North pole passing the coil. This produces an excellent sine wave output in the coil.

The additional switching is performed by a mechanical brush and contact system and the power collection circuit used for the short-circuited coil is:

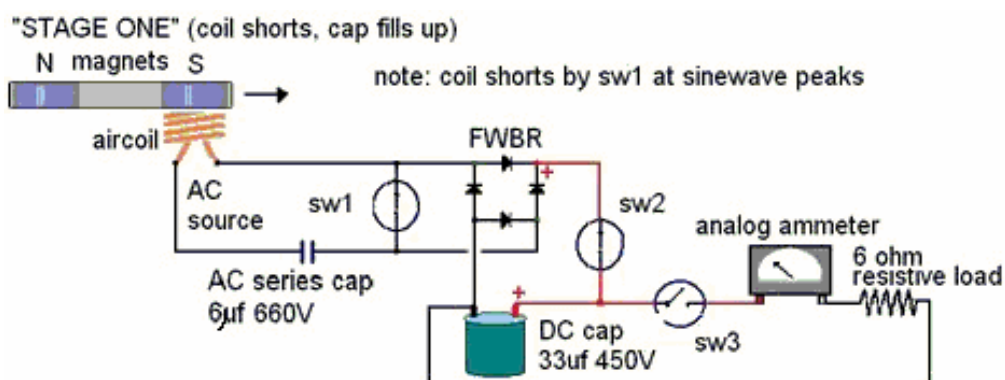

and when the coil is not short-circuited, the circuit is:

"STAGE TWO" (cap unloads to load while source disconnects)

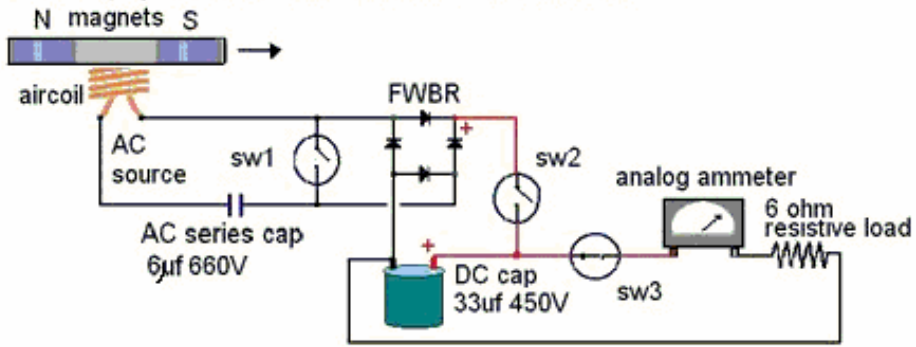

Doug Konzen has been developing this circuitry and generously sharing his results freely. His web site is at <http://sites.google.com/site/alternativeworldenergy/shorting-coils-circuits> and his most recent practical circuit is:

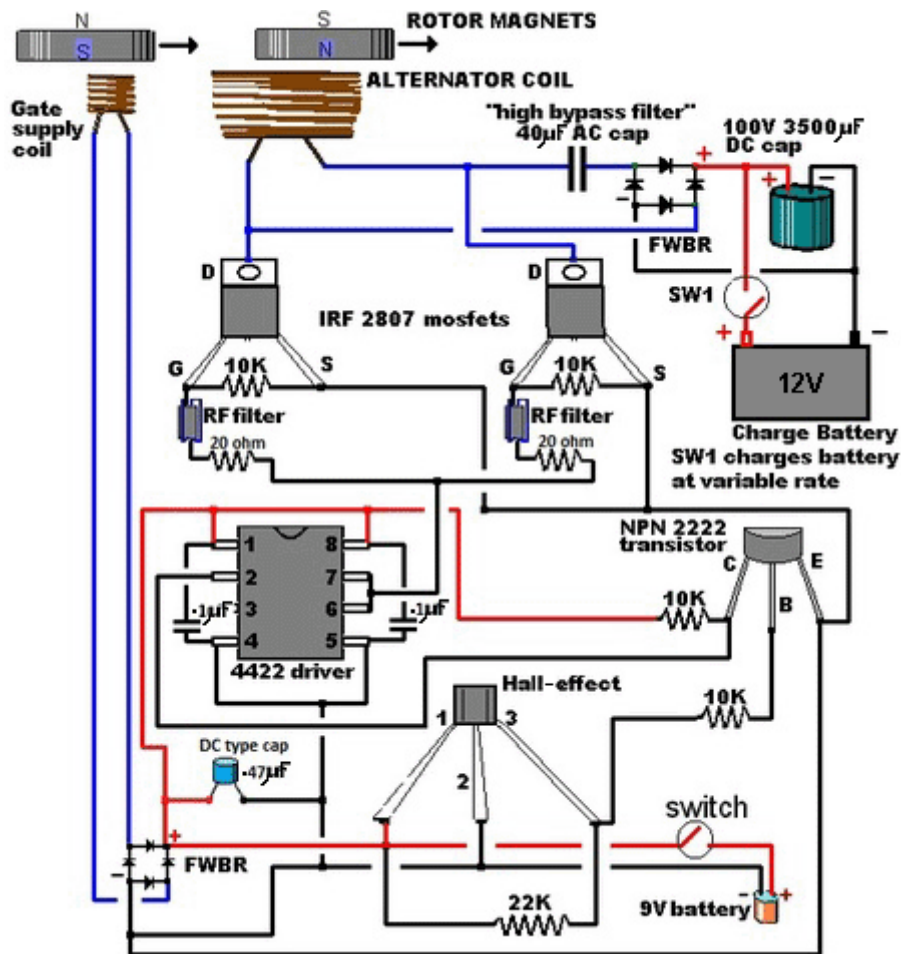

There is a video on the web where coil-shorting is used on the output from a replication of John Bedini's Window Motor. John's Window Motor is a cylinder with magnets mounted in it, spun inside a large coil by a pulsed motor:



The motor can be a self-runner, but for the coil-shorting demonstration, it was just spun briefly by hand, producing voltage pulses of about 16 volts. When the coil-shorting is switched on, those pulses rise to about 440 volts even

though the coil shorting was not the optimum five times at peak (which would probably have raised the voltage pulses to about 1,600 volts). The oscilloscope displays of the test shown on video are:

keykhin: <http://www.youtube.com/watch?v=5GUyocU7XM8>

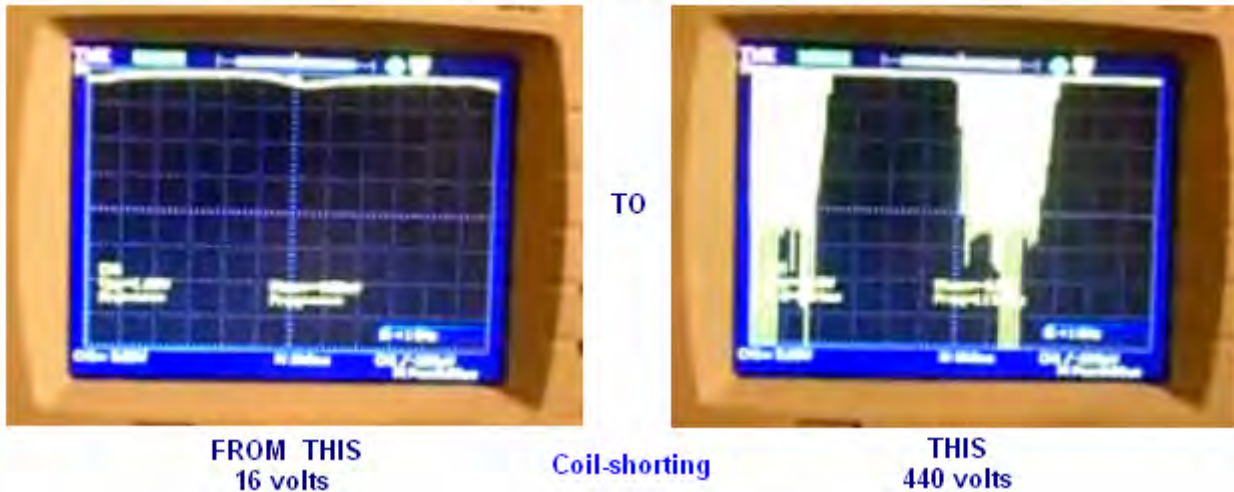

I'm told that this coil-shorting technique is used in industry but is considered to be a 'trade secret'. Details of John Bedini's Window Motor can be found at <http://www.fight-4-truth.com/Schematics.html>.

Raoul Hatem's Magnetic Coupling System.

Generally, the RotoVerter has very low input power when not loaded and about a 90% energy reduction when under load. The ideal situation is where there is a constant load as the tuning of the RotoVerter does depend to some degree on the load. However, the RotoVerter performance can be increased very substantially by using the techniques introduced by Raoul Hatem in 1955, which conventional science will not accept because according to current theory, any such energy gain has to be "impossible" and so, cannot happen no matter what evidence there is:



Raoul Hatem's heretical statement is that using spinning magnets draws in energy from the environment, allowing a system to have COP>1 (ever heard of John Searle's spinning magnet systems?). His method is to use a motor (whether RotoVerter or not) to spin a heavy rotor disc with 36 powerful rare-earth magnets mounted on it. Then, using an identical heavy disc with magnets mounted on a generator to give a magnetic coupling between the motor and the generator can give not just coupling, but an energy gain as well:

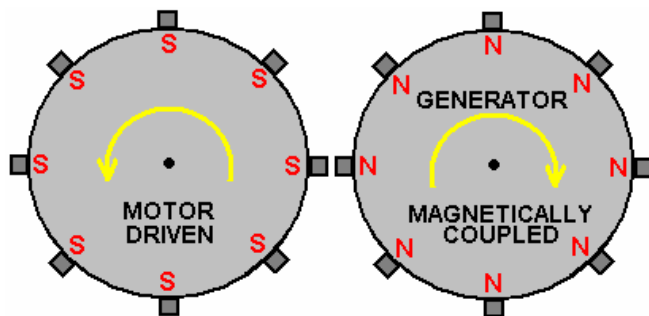

The heavy rotor provides some flywheel effect which helps with the operation of the system. Even with one motor as shown above, there is an energy gain as demonstrated in a recent video demonstration of the effect at http://www.dailymotion.com/video/xi9s9b_moteur-magnetique-de-leon-raoul-hatem_webcam#.UaGyVTcr6Bo where a simple system produces 144 watts of excess power. However, the really big gains are got when several generators are driven by just the one motor. In passing, it may be remarked that there are two separate energy gain systems operating here. Firstly, the rotating magnetic field acts directly on the excess electrons in the local environment, drawing them into the system just as the fluctuating magnetic field of the secondary winding of any transformer does. Secondly, the rotors are receiving a rapid stream of drive pulses, and as Chas Campbell has demonstrated, that draws in excess energy from the gravitational field.

Anyway, you will notice that the powerful magnets used have their North poles outwards on one rotor while the adjacent rotor has the South poles outwards. The very strong attraction between these opposite poles cause the generator disc to rotate in step with the motor disc. This process allows many generators to be driven by just the one motor as shown here and in the photograph above:

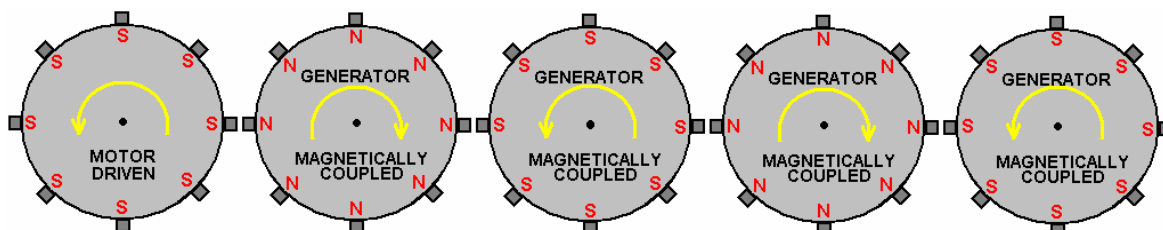

For ease of drawing, the diagram above shows only eight magnets per rotor disc, but you will notice in the photograph (and in the video) that there are three stepped rows of magnets on each rotor:

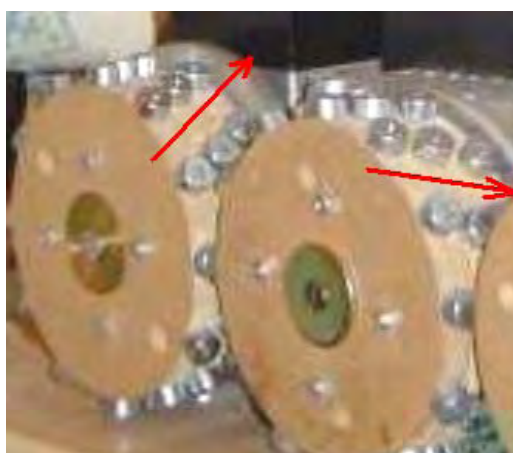

You will also notice that direction of the stepping is reversed on every second rotor disc in order for the magnets to match each other in position as they rotate in opposite directions.

While this type of arrangement gives a major increase in the output power compared to the input power, the situation can be further enhanced by retrieving some of the input power by means of electronic circuitry, and both Phil Wood and David Kousoulides have kindly shared their methods for doing this.

Lawrence Tseung's COP=3.3 Pulsed-Flywheel.

Lawrence has been presenting his theory of lead-out energy which indicates that excess energy is drawn from the environment when there is an impact. The method of producing this effect which he has followed is to create an unbalanced wheel and demonstrate that excess energy is produced. It should be stressed that energy is never created or destroyed and so, when he measures more energy in his device than the energy which he uses to power it, energy is not being created but is instead, being drawn in from the local environment. Lawrence has recently demonstrated a prototype to members of the public:

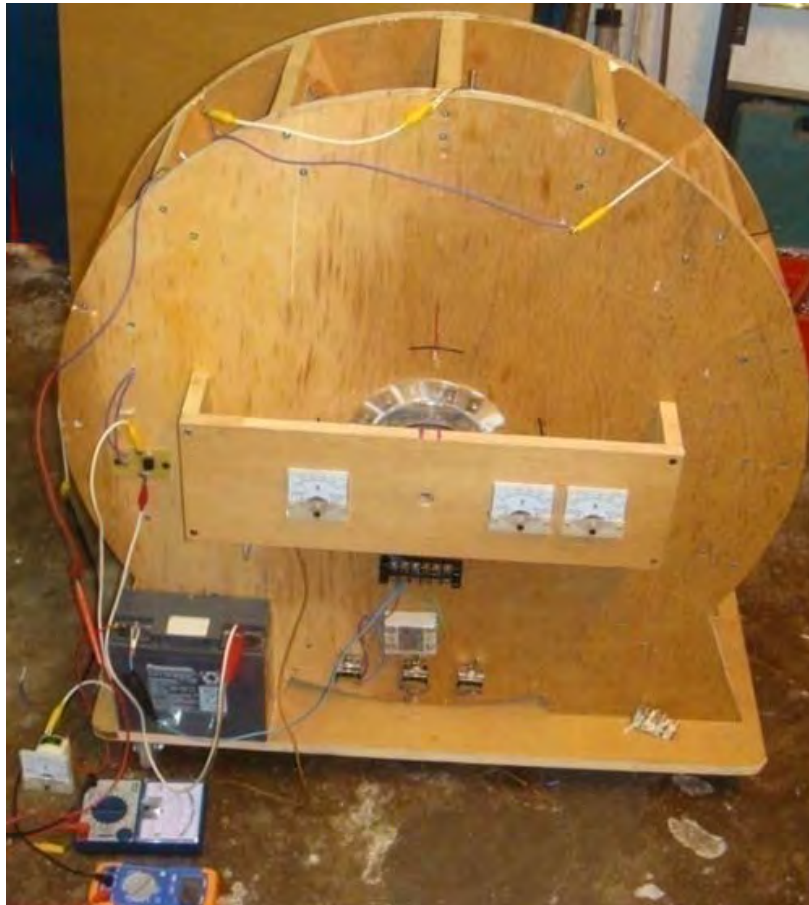

This simple device was demonstrated to have 3.3 times as much output power as the input power needed to make it operate. This is an early prototype which was demonstrated in October 2009 and Lawrence and his helpers are working on to produce more advanced models which have kilowatts of excess electrical power.

Mr Tseung remarks: "The **Lee-Tseung Lead-Out Energy Theory** was first disclosed to the world on 20th December 2004 at Tai Po, in Hong Kong. The Lead-Out Energy Theory basically says that one can lead-out (or bring-in) Energy from the surrounding environment into a Lead-Out Energy Machine. The total Input energy is equal to the sum of the Supplied Energy plus the Lead-Out Energy. For example, if the supplied energy is 100 units and the lead-out energy is 50 units, the device's total Input Energy will be 150 units. This means that the Output Energy can be more than the Supplied Energy of 100 units provided by the person using the device.

If we ignore the small loss of energy caused by less than 100% efficiency of the device itself, then the Output Energy will be the whole of the 150 units. If we use 50 of the output energy units and feed back 100 of the output units as the Supplied Energy, then that Supplied Energy can again lead-out another 50 units of excess output Energy for us to use. Thus a Lead-Out Energy Machine can continuously lead-out pollution-free, virtually inexhaustible and readily available energy for us to use. We do not need to burn any fossil fuel or pollute our

environment. The two examples of Lead-Out energy which we access are Gravitational and Electron-Motion energy.

The Lead-Out Energy theory does not violate the Law of Conservation of Energy. The Law of Conservation of Energy has been used as a roadblock for the so called "Overunity" devices. The patent offices and the scientific establishment routinely dismiss an invention as belonging to the impossible "perpetual-motion machine" category if the inventor cannot identify the energy source of his invention.

We got the help of Mr. Tong Po Chi to produce a 60 cm diameter Lead-Out Energy machine in October 2009. The Output Energy of that device is greater than the Input Energy by a factor of 3 times. These results are confirmed by voltmeters and ammeters measuring the Input and Output energies.

The Tong wheel has been shown at two Open Shows in Hong Kong (Inno Carnival 2009 and Inno Design Tech Expo) in November and December 2009. Over 25,000 people have seen it. The Better Hong Kong Radio Show has video recorded it, the discussions being conducted in Chinese. At this time, the Tong wheel is at the Radio Studio available for experts to view and examine with their own instruments."

The Tong wheel has a diameter of 600 mm and this large size is considered to be important. It has 16 permanent magnets mounted on its rim and 15 air-core coils mounted around it on the stator. There is one position sensor. The coils can be switched to act as drive coils or as energy collection coils:

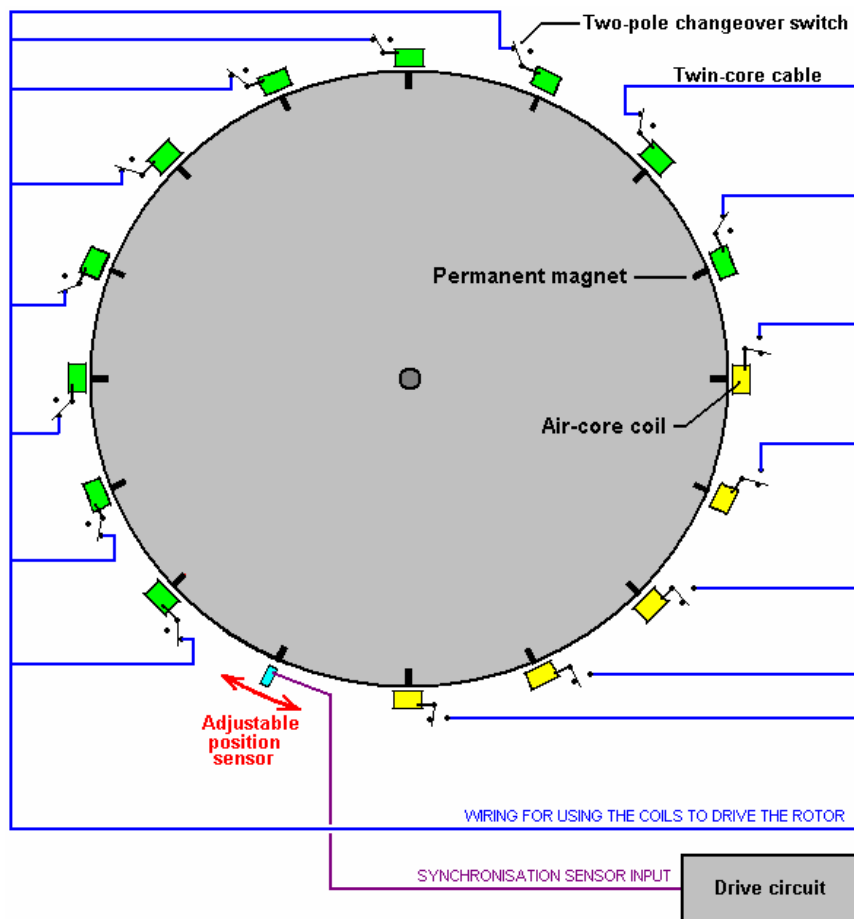

With this arrangement, if the positions the switches as shown for ten of the fifteen coils shown here, then they act as drive coils. The sensor is adjusted so that the drive circuit delivers a brief energising pulse to those coils just after the magnets have passed their exact alignment position with the coils. This causes them to generate a magnetic field which repels the magnets, thrusting the rotor around.

The pulse is very brief, so very little power is needed to accomplish this pulsing. As mentioned before, any number of coils can be switched to provide this driving force. With this particular wheel construction by Mr Tong, the best number has been found to be ten drive coils.

The power pick-up is achieved by gathering the electricity generated in some of the coils as the magnets move past them:

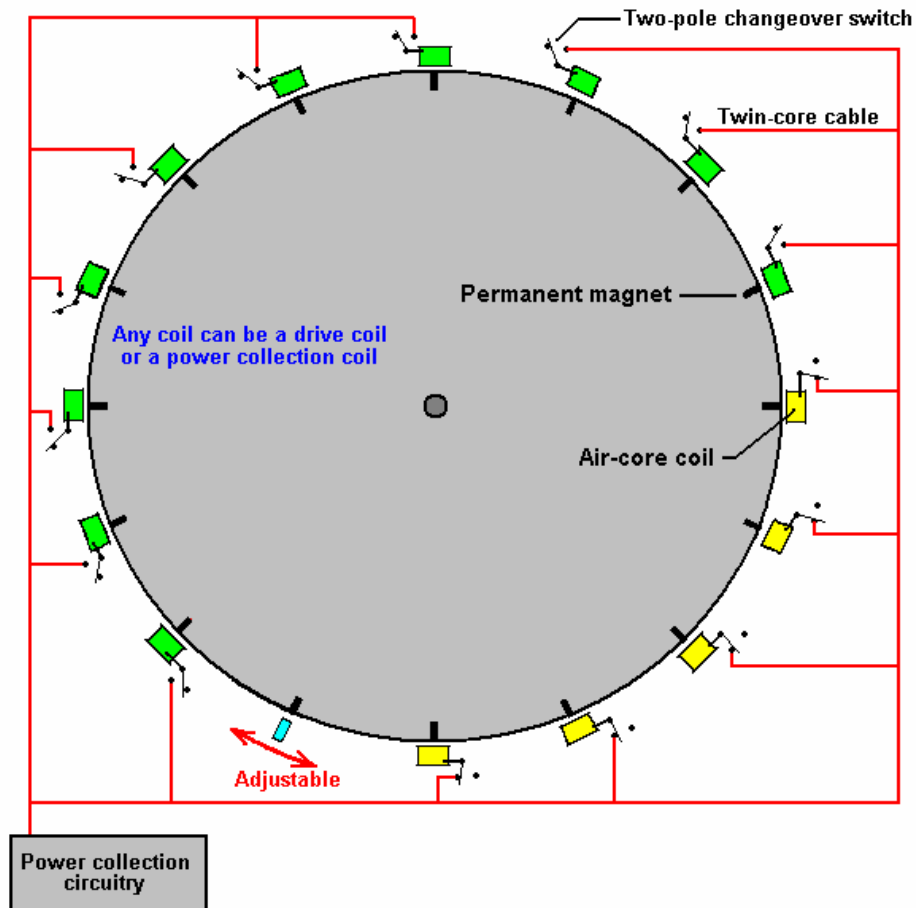

In this particular arrangement, five of the coils gather energy while ten provide the drive. For the sake of simplicity, the diagram shows the five collection coils adjacent to each other and while that would work, the wheel is better balanced if the drive coils are evenly spaced out around the rim. For that reason, this switching would actually be selected to give five sets of two drive coils followed by one pick-up coil as that gives a perfectly balanced thrust on the wheel.

The two diagrams above are shown separately in order to make it clear how the drive switching and the power pick-up switching are arranged. The full design arrangement and the balanced switching are shown in the following diagram which indicates how the full design is implemented on this particular implementation of the wheel design. The sensor can be a coil feeding a semiconductor switching circuit, or it can be a magnetic semiconductor called a Hall-effect device which can also feed a semiconductor circuit. An alternative would be a reed switch which is a simple mechanical switch encased in an inert gas inside a tiny glass envelope. Suitable switching circuits are described and explained in chapter 12 of this eBook.

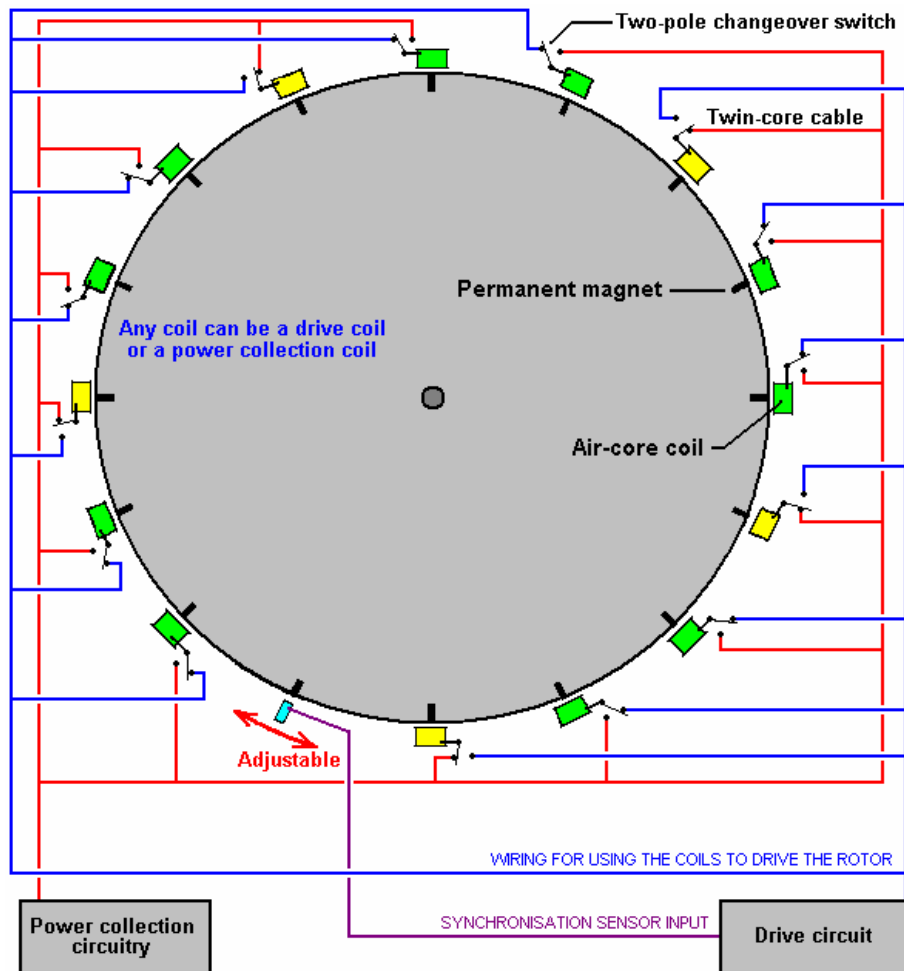

Mr Tseung remarks that the large wheel size is due to the fact that the Pulse Force takes time to impart the impulse to the wheel and lead-out energy from the environment into the system. If you want to see this actual wheel, you can email Dr. Alexandra Yuan at ayuan@hkstar.com to make an appointment. The Tong wheel is located at the Better Hong Kong Radio Studio in Causeway Bay, Hong Kong. Just say that you want to see the Lead-Out Energy Machine. The demonstration can be in English or in Chinese. Ideally, there should be a group of at least six visitors with one or more being a qualified engineer or scientist, and you are welcome to bring your own cameras and/or test equipment. It is planned to produce a version which has a 300 watt output, and another with a 5 kilowatt output. Educational kits are also planned.

If you decide to replicate this particular design, then to raise the output power level you might consider putting another set of coils around the wheel and either using them as fifteen additional energy pick-up coils or alternatively, pulsing the wheel twice as often. Adding one or more additional rotor discs to the same rotating shaft is also an option and that has the advantage of increasing the rotor weight and improving the effect of the impulses on the rotor.

The diameter of the wire used to wind the coils is a design choice which has a wide scope. The thicker the wire, the greater the current and the larger the impulse given to the wheel. The coils are normally connected in parallel as shown in the diagrams.

Because of the way magnetic field strength drops off with the square of the distance, it is generally considered good design practice to make the coils one and a half times as wide as they are deep, as indicated in the diagrams above, but this is not a critical factor. This design is, of course, a version of the Adams motor described at the start of this chapter. Although motors of this kind can be built in many different ways, the construction used by Mr Tong has some distinct advantages, so here is a little more detail on how I understand the construction to be carried out.

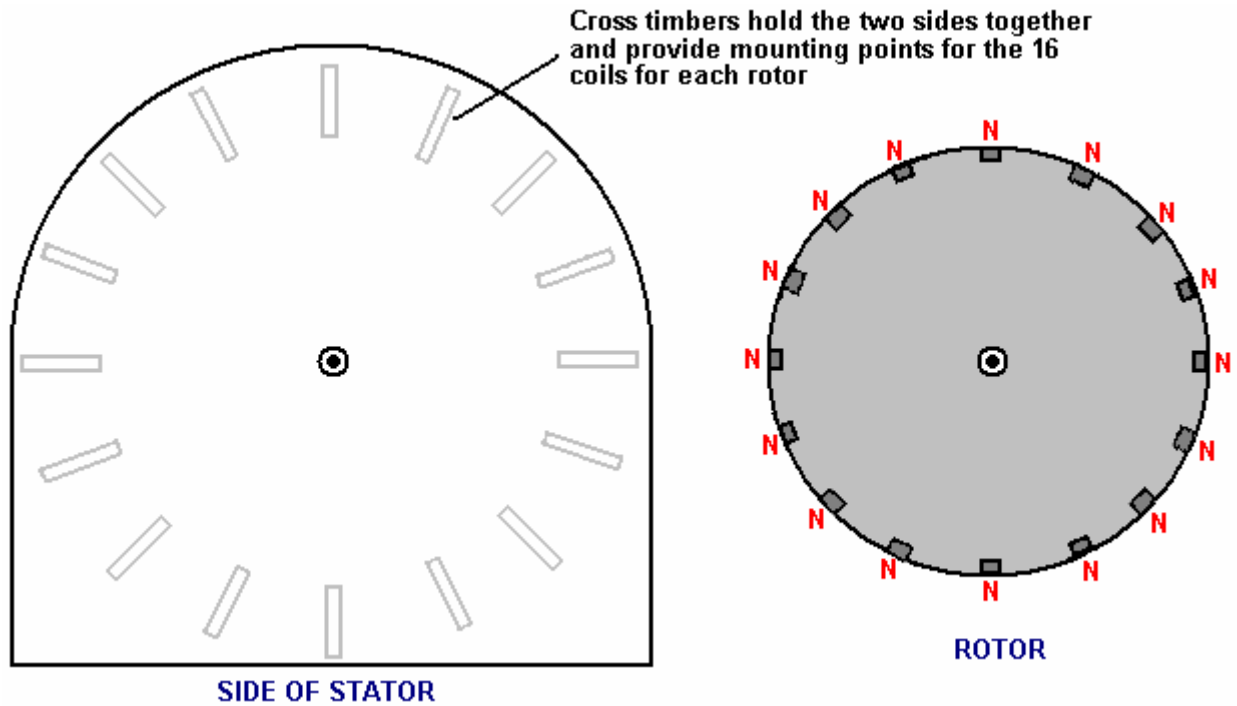

There are two side pieces which are attached together by sixteen cross timbers, each of which are held in place by two screws at each end. This produces a rigid structure while the construction method is as simple as is possible, using readily available materials which are worked with the most basic of hand tools. The construction also allows the motor to be taken apart completely without any difficulty, transported as a "flat-pack" package and then assembled at a new location. It also facilitates people who want to see the motor taken apart after a demonstration in order to assure themselves that there is no hidden power source.

Each of the cross timbers provide a secure mounting platform for an electromagnet and its associated switch. In the implementation by Mr Tong, there appears to be just the one rotor, configured as shown above with sixteen permanent magnets mounted in its rim. The magnetic poles of these magnets are orientated in the same direction. That is to say, the magnetic poles facing outwards are all either South or all North poles. It is not critical whether the outward facing poles are North or South as Robert Adams used both arrangements with great success, but having said that, most people prefer to have North poles facing outwards.



all
the

Robert has always said that one rotor was enough, but his techniques were so sophisticated that he was able to extract kilowatts of excess power from a single small rotor. For us, just starting to experiment and test a motor of this type, it seems sensible to stick with what Mr Tong has experienced success. However, this build by Mr Tong is not his final motor but just one in a series of continuously improved motors.

The following diagram shows an arrangement which has three rotors attached to a single shaft and while you may choose to construct this with just one rotor, if the cross timbers are long enough, then one or two extra rotors can be added in very easily at a later date.

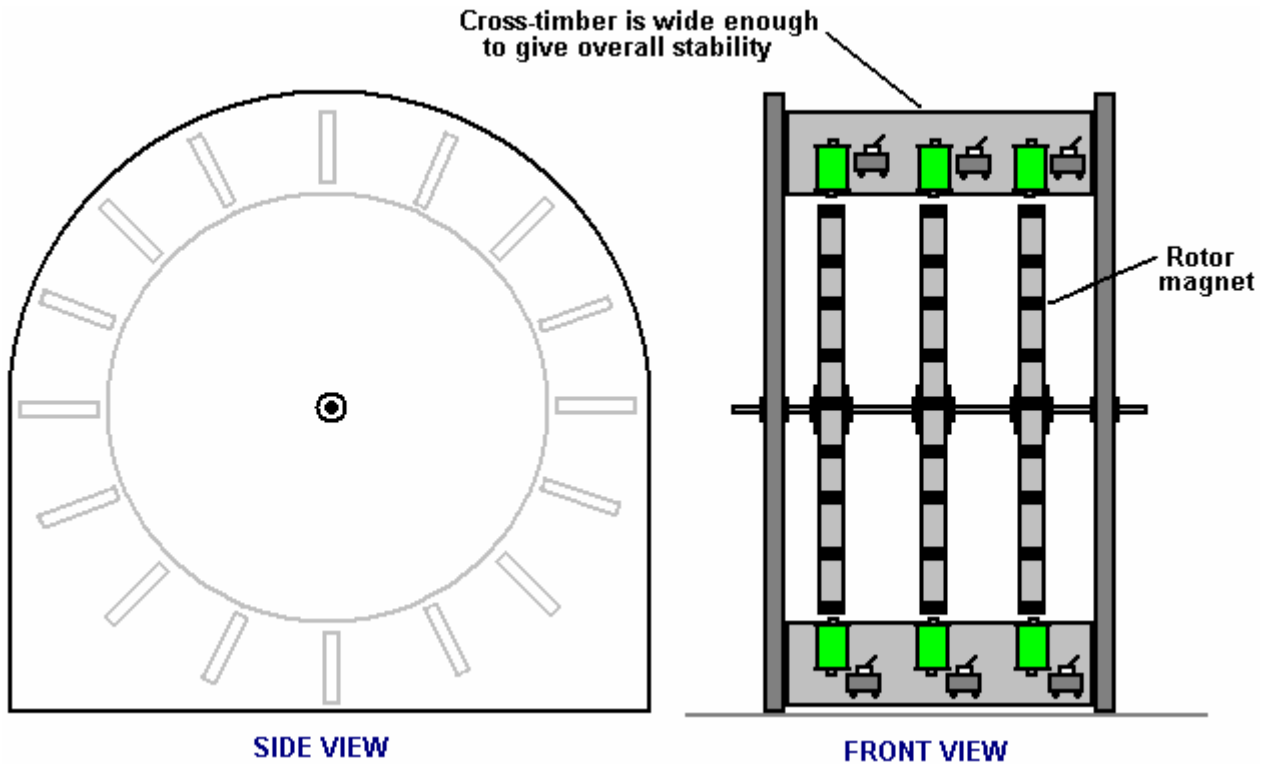

Here, just two of the cross timbers are shown. The electromagnet coils used by Mr Tong are air-core as that type have the least effect on the passing magnets. However, electromagnets with cores tend to be much more power for any given current flowing through them. In theory, the core should be made of lengths of insulated iron wire as that would reduce power loss through eddy currents flowing in the core, but Robert actually recommends solid metal cores, and as he was the most experienced person in this field, paying attention to what he said seems sensible.

The core material needs to be a metal which magnetises easily and powerfully, but which does not retain any of its magnetism when the current stops flowing. Not many metals have those characteristics and soft iron is usually recommended. Nowadays, soft iron is not always readily available and so a convenient alternative is the central bolt of a masonry anchor which has excellent properties:



The shaft of the bolt can be cut quite easily with a hacksaw, but be sure to remove (or file down) the head of the bolt as the increase in diameter has a marked effect on the magnetic properties of the electromagnet core if it is left in place. The bolt shown above is a M16 x 147 mm masonry anchor bolt with a bolt diameter of 10 mm. Some makes of dry-ink felt white-board markers have a rigid body which fits the 10 mm bolt exactly and provide an excellent tube for constructing an electromagnet bobbin.

With a core in the electromagnets, the rotor gets additional rotating power. Initially, the magnets on the rotor are attracted to the electromagnet cores, giving the rotor a turning force which does not require any current to be supplied. When the rotor magnets are at their closest point to the electromagnet cores, the windings are powered up briefly and that gives the rotor magnets a strong push away, causing the rotor to spin.

There are many different designs of simple drive circuits and it is probably worth trying out different types to see which works best with your particular build of motor. In the same way, there are many kinds of collection circuits for taking off some of the excess power generated. The most simple of these is just a diode bridge, perhaps feeding a battery and charging it up for use at a later time. If you get sophisticated with the collection circuit and just take power off for a very short period of time at the correct moment, the cutting off of the current draw, causes a back-EMF magnetic pulse in the collection electromagnet which causes it to give the rotor an extra drive push – both current collection and rotor drive in one combined package.

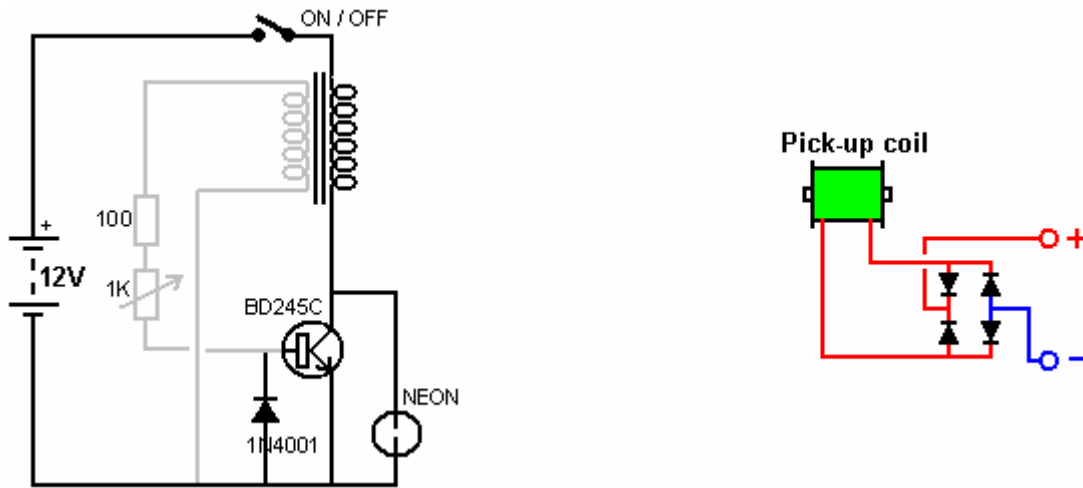

Here are two of the most simple circuits possible, one for drive and one for power collection. The drive circuit transistor is switched on by a voltage generated in the grey coil by a rotor magnet passing by. The transistor then feeds a large current pulse to the black coil, driving the rotor on its way. The neon and the diode are there to protect the transistor and a physical layout for this circuit might be:

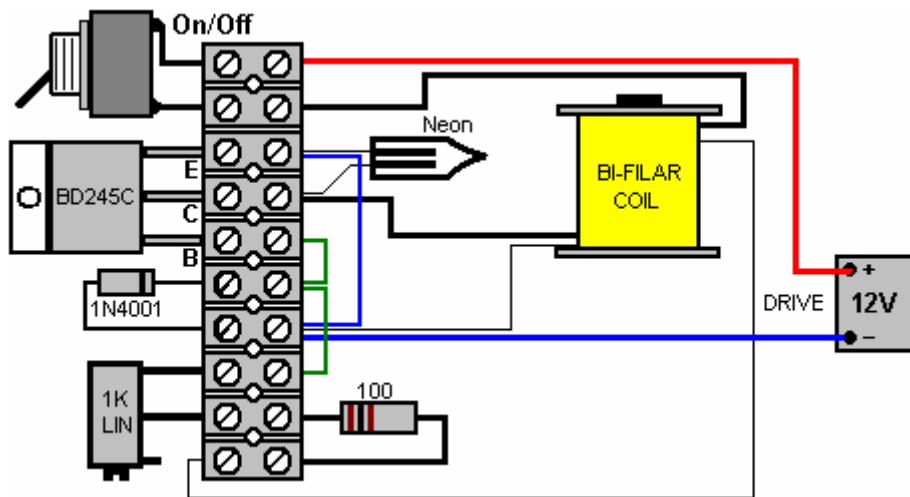

The 1K variable resistor is adjusted to give the best performance and the On/Off switch is optional. More advanced circuits, such as the one on page 2 - 9 can also be tried and the performance compared. Generally speaking, I would expect a three-rotor version to give a better performance than a single rotor implementation, but experimentation is needed.

Art Porter’s Magnetic System.

Art uses an electromagnet with a ring magnet mounted on the core. When the coil is pulsed so as to augment the field of the permanent magnet, Art says that his prototype produces 2.9 times the field strength of the permanent magnet on it’s own. When the coil is pulsed in the direction which opposes the field of the permanent magnet, the resulting magnetic field is zero.

This is a very serious change of magnetic field which can be used in different applications. One which Art has implemented is using the arrangement to power a crankshaft motor. Art shows several different motor builds including this one:

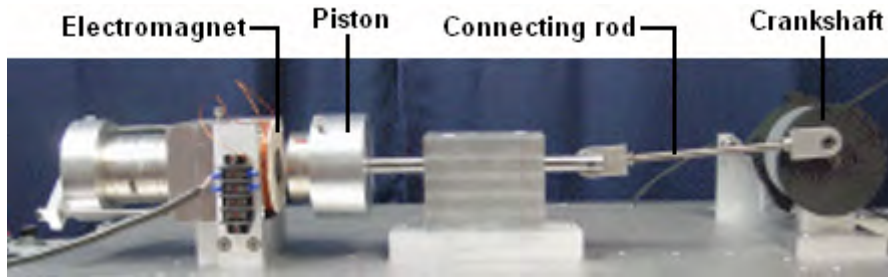

With this arrangement, Art states that 95% of the motor power comes from the permanent magnet. Art's website is at <http://www.gap-power.com/index.html> and he has a very interesting, lengthy video showing all of the details at <http://www.gap-power.com/videos/Full%20Length%20Video.wmv>.

In the video, Art attempts to apply Ohm's Law in an attempt to analyse the operation and is puzzled when the oscilloscope readings do not match his Ohm's Law calculations. He thinks that there is a contradiction between the oscilloscope and Ohm's Law, which he repeatedly stresses is a law of Nature, and he concludes that one of them has to be wrong. In actual fact, neither are wrong because Ohm's Law only applies to DC current flow in resistive circuits, and Art is not using steady DC current or a resistive load.

Applying short DC pulses to a substantial coil of wire is the equivalent of applying AC to that inductor. Ohm's Law does not apply due to the inductance of the coil. There is a Power Factor involved and Back EMF voltage pulses, so the oscilloscope readings are what is needed to calculate the input and output powers.

This arrangement is almost identical to that used in the Charles Flynn magnet motor described in chapter 1, and very close to the techniques used by Robert Adams in a properly tuned Adams Motor as shown at the start of this chapter. In my opinion, the effect which Art is exploiting would best be used if a large pick-up coil is placed against the end of the electromagnet core and the drive coil pulsed at the coil's (high) resonant frequency as that will minimise the input power and maximise the output power. Stacking those units in a bank could well produce a very sizeable excess electrical output. Our thanks are due to Art and his colleagues for sharing their research work freely for others to replicate and progress further.

DC Motor Efficiency

Commercially available DC motors are deliberately designed and manufactured to have extremely poor performance. In my opinion, the reason for this is that a properly designed electric motor could easily do away with the need for using internal combustion engines in vehicles and that would not suit the oil companies or their owners, the New World Order cartels. Worse still, electric motors with COP>1 open the way to self-powered free-energy systems and that would never do !!

The video: <http://torrentdb.in/95d95cff2bbC8039ed9/Peter-Lindemann-Electric-Motor-Secrets.torrent> is available on the web and I strongly recommend that you watch all of it. It presents the basic facts very nicely. In brief outline, present day motors act both as a motor and as a generator of electrical power, but they are deliberately wound so that the power generation is used to oppose the input power and so produce a completely crippled output. During World War II, a German Engineer re-wired a standard electric motor and made it self-powered, that is, it ran and produced mechanical output power without the need for any input power once it had been started. That shows the potential of a properly constructed electric motor with the same size and general structure of any commercial electric motor.

Presumably, he did that by adding extra brushes and using some of the windings in generator mode with their output powering the drive windings which were arranged asymmetrically. There was also one other man who achieved self-powered re-wiring of a motor, but neither of those men made their information public knowledge.

The con job which has been run on us for many decades now is to wind the motor in such as way that the magnetic fields inside the motor oppose each other. When a current is passed through a coil of wire, it stores energy in that coil, and when the current flow is cut off, that energy needs to flow back out of the coil and it will do so in the reverse direction. This is sometimes called back-EMF ("Electro-Motive Force") although many people are not happy with that description. However, no matter what you call it, there is energy stored in the coil and that energy can be used to do useful work. But, the motor manufacturers choose to wind the motor so that instead of extracting that useful power, they use it to oppose a major part of the input power, creating a weak motor which heats up due to the wasted energy.

Contributor “UFOpolitics” points out that a deliberate mis-design of electric motors has, for the last 130 years, been presented to us as the only way to make and operate such motors. He states that because the windings are arranged in a symmetrical way, that a braking effect is produced which reduces the output power of the motor by anything from 50% to 90%. That is, a properly wound motor would have anything from twice to ten times the output power for the same input power. This mis-design guarantees that present day motors are always less than 100% efficient and always heat up when run. This mis-design is caused by using symmetrical windings in the motor.

Standard motor wiring is quite different and the killer effect is caused by having two windings which face each other, powered simultaneously with currents flowing in opposite directions. This causes a complete conflict between the magnetic fields and that destroys the efficiency of the motor: A very experienced experimenter has started a forum thread on the energetic-forum, both to explain this and to show new and more advanced construction methods and to answer questions and encourage replications and further developments. The forum is at: <http://www.energeticforum.com/renewable-energy/11885-my-asymmetric-electrodynamical-machines.html> and is definitely worth visiting, especially if you are good with mechanical devices. The experimenter uses the forum ID of “UFOpolitics” and he has produced an animated video in an attempt to explain the basic problems with present day DC electric motors: <http://www.youtube.com/watch?v=Mj4rV0Aol-Q&feature=channel&list=UL>. He points out that a problem winding in the standard DC motor looks like this:

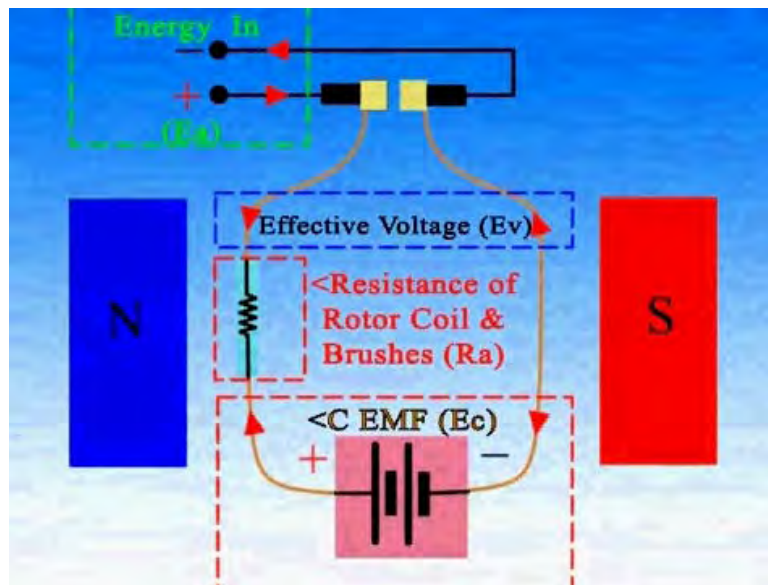

The input current for any winding is fed in through a single pair of brush contacts. The generated electrical power “Ec” is not extracted and is forced to oppose the input energy “Ea”, leaving only a fraction of the input power to actually run the motor. It is likely that a motor of this type will only operate at 25% of its potential efficiency.

“UFOpolitics” has produced and demonstrated a simple way of overcoming this problem while using the existing motor housing, magnets and brush contacts. He does this by extracting the generated electrical power as a useful output and so preventing that useful power being used against the motor’s operation. To implement this, he adds one additional pair of brushes and re-winds the motor coils like this:

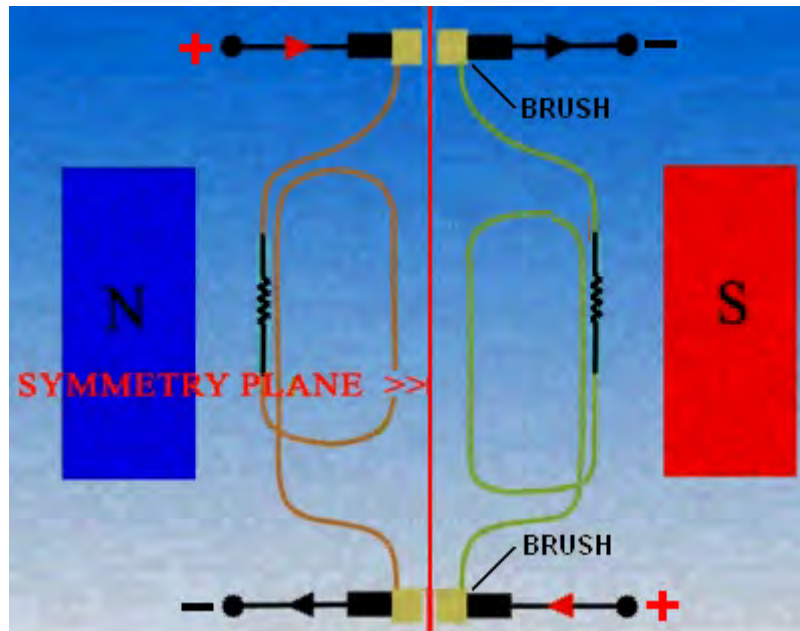

Here, one pair of brushes is at the top and one pair at the bottom of the 'armature' (the bit that rotates inside the motor housing and provides the mechanical power output). The coils are rewound to form a series of separate vertical coils, connecting to one brush terminal at the top and one brush terminal at the bottom as shown above.

The input power is between the terminals on the left and flows through the coil shown in brown. The current flow generates a magnetic field, causing rotation because of the Permanent magnets marked "N" (for a magnet which has its North pole facing the coils) and "S" (for a magnet which has its South pole facing the coils). The black zig-zag line represents the resistance to current flow of the wire and brush contacts.

The coil shown in green on the right represents that same coil at a later moment when it has been disconnected from the power supply and rotated until it reaches that position, at which point, the energy stored in it is taken off as a useful output via the right hand pair of brushes. However, this is just an explanatory diagram and it does not show the very important fact that the discharging coil **must not** directly face a driving coil, because if it does, then the energy discharge would create a magnetic field which would interfere with the magnetic field of the driving coil and create a major problem.

Right, to say that again, any one coil is powered on the left hand side to drive the armature around and provide the output shaft with turning power ("torque"). Then that rotation disconnects that coil from the input power, leaving the coil charged with energy which has nowhere to go. That charged coil continues round until it hits the second set of brushes, which allow it to discharge through a load and do useful work.

The really clever part of the adaption of the motor is best seen from above the vertical rotor. If, for example, you were to take a five-pole DC motor apart and remove the windings, the shaft and armature body might look like this:

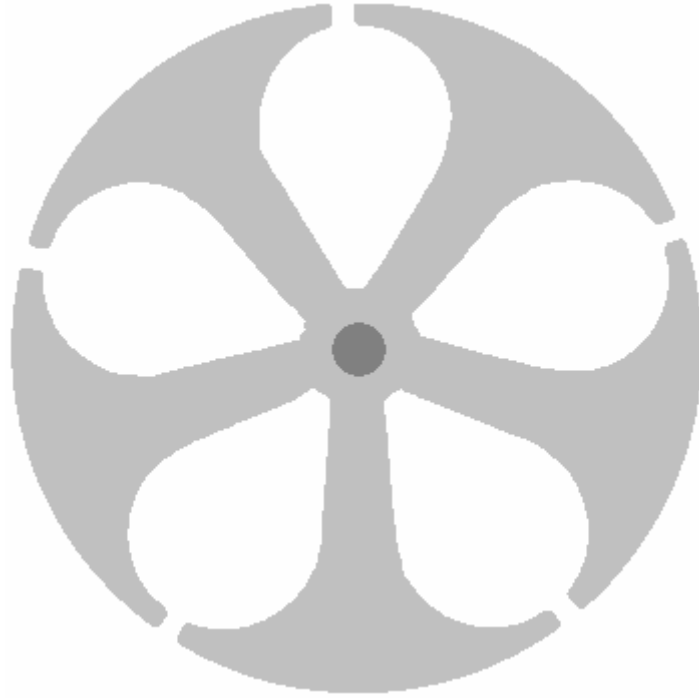

When making an asymmetrical wound rotor, the windings go like this.

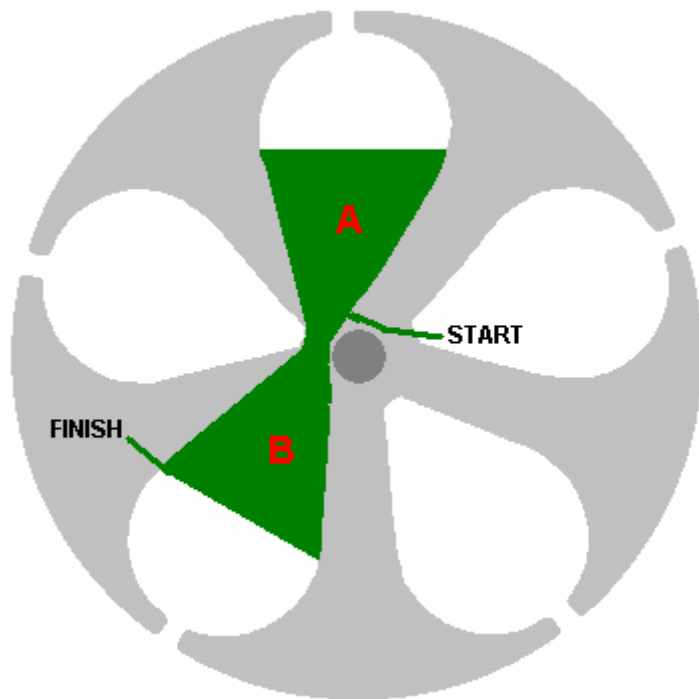

The start of the wire is secured at the top and then fed downwards through the opening “A” and back up through the opening “B”. For the small Radio Shack motor, this winding would be 25 turns of # 30 AWG wire (described as radio Shack ‘red’ wire, with a copper wire diameter of 0.255 mm). If you are re-winding a motor armature, please understand that each wire turn needs to be pulled tight in order to make a tight, solid and robust coil which will not vibrate unduly when the armature is spinning.

The end of the wire marked “FINISH” is **not** cut, but is taken down through opening “A” and this time, up through opening “C”. For clarity, these continuing turns are shown in a different colour, but please realise that it is the same single strand of wire being used throughout:

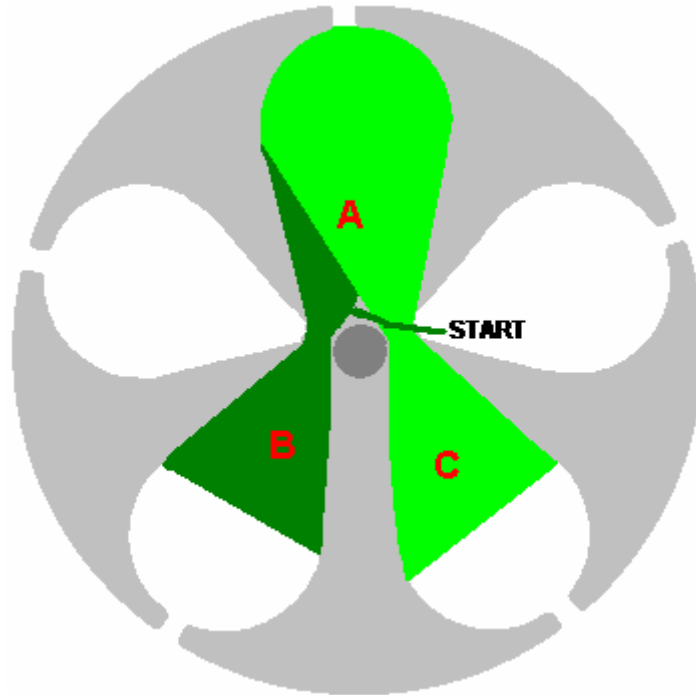

The final wire turn goes down through opening “A” and finishes at the other end of the body of the armature. In these views, the wire runs down into the paper, each turn forming a cylinder. This view may give you a better visual picture of what the coils are wound on:



The next step is to connect the START and FINISH wire ends of this V-shaped double coil to the “commutator” slip rings which allow current to be passed through the coil at just the right moment. Seen again from one end of the armature, the connections are like this:

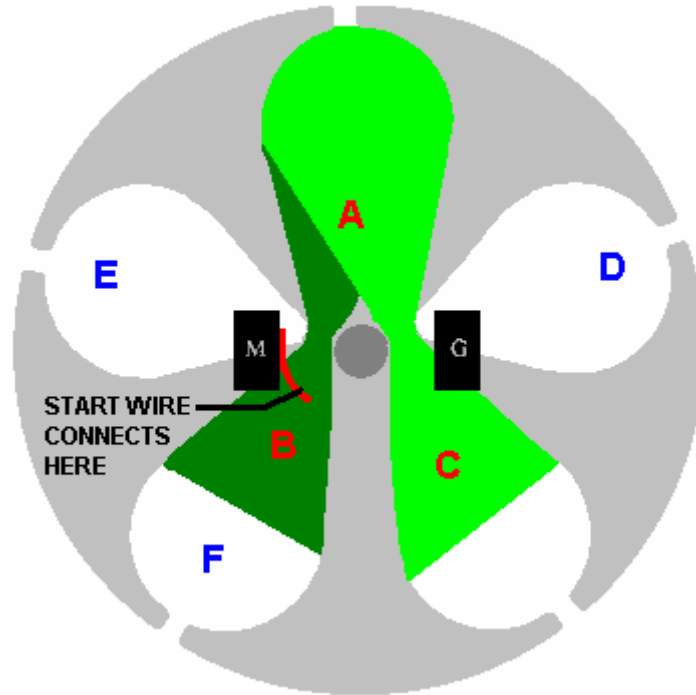

The commutator slip rings are connected further up on the drive shaft and the start of the winding wire (shown previously in dark green) is connected to the top commutator sector in the position shown here. The finishing end of the wire is connected to the corresponding commutator sector at the far end of the shaft – that is, the sector directly in line with the upper sector just connected to the start of the wire.

This completes the first of five identical V-shaped coils. The next coil is wound in the same way. The armature is rotated one sector counter-clockwise so that sector “D” replaces “A” at the top and the next coil is wound with the wire starting at the top and going down through opening “D” and up through opening “E”, repeating the same number of turns, and then, without cutting the wire the next set of wires are wound going down through opening “D” and back up through opening “F”. The start of the wire is then connected to the commutator sector which spans between openings “A” and “E” and the end connected to the corresponding commutator sector at the other end of the shaft..

For each of the remaining three windings, the shaft is rotated one position counter-clockwise and the same winding and connecting procedure carried out. When completed, no matter which opening is placed at the top of the view along the shaft, the windings and commutator sector for the wire connections will be identical.

3-Pole Motors

The winding arrangement is slightly different for motors which have three poles (or multiples of three poles such as 6, 9, 12, etc poles). For the very simple 3-pole motors, the armature looks like this:



and with this style of armature, the winds are around the three arms, like this:

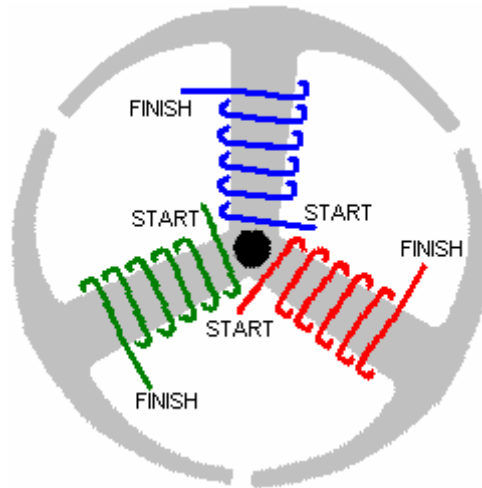

And as before, the commutator sectors at the top are duplicated at the bottom, allowing separate input and output circuits for each of the three coils. The windings have many turns, filling the available space and each winding is connected to the slip ring sector directly opposite it, like this:

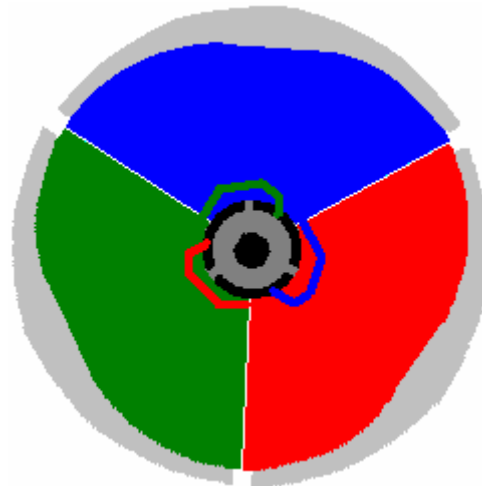

The Start of each winding is connected to the commutator slip ring sector at the top of the armature and the Finish is connected to the slip ring sector directly below it, that is, the sector which is at the same angle as the top one where the Start of the wire is connected. This allows the brushes which press against the slip ring sectors to connect to both ends of each coil in turn as the armature rotates. Three pole motors are particularly powerful and motors with six poles can be re-wound with pairs of adjacent sectors amalgamated to give three larger sectors. Nine pole motors can have three adjacent sectors wound as a single coil to provide the same effect as a three pole motor, and twelve pole motors can have four adjacent sectors wound as a single coil.

The positioning of the brushes is important. With the three-pole and five-pole arrangements, the brushes are aligned with the gaps between the magnets which surround the armature. However, the re-wound motor can be 'tuned' for improved torque and reduced drive current by adapting the motor housing to allow some adjustment of the position of the brush and commutator slip rings relative to the coils. This adjustment need only be slight as the angular movement of the brushes will be small. It is, of course, essential that the upper and lower adjusted positions move by exactly the same angular amount so that every upper commutator slip ring sector remains exactly above its corresponding lower slip ring sector. In other words, the commutator slip ring sector at the top and bottom of each coil, must be exactly aligned vertically so that the electrical connections are made and broken at exactly the same instant

The commutator and brush arrangement are shown here in UFOpolitics' diagrams:

UFOPOLITICS ASYMMETRICAL THREE POLES

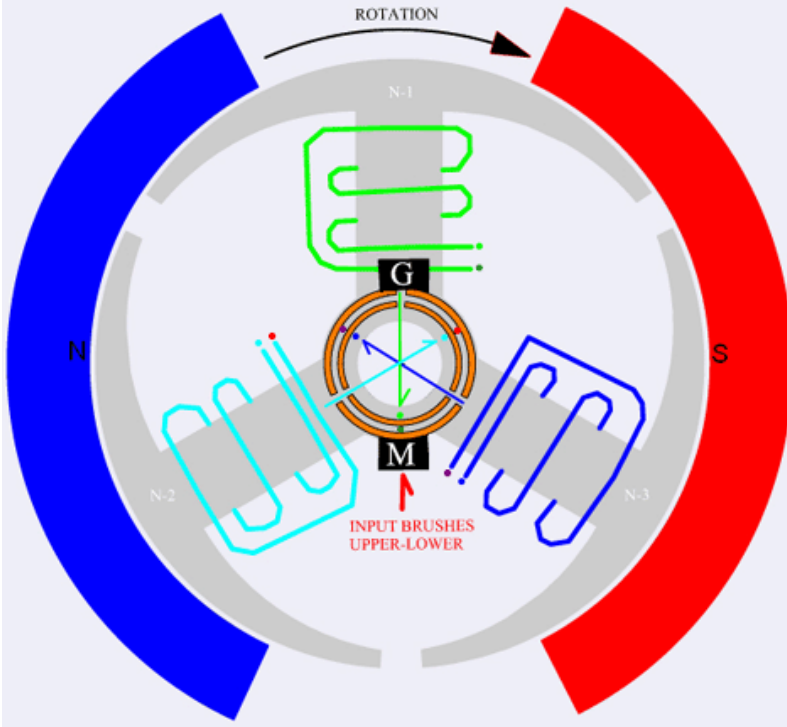

THREE POLE ASYMMETRIC MOTOR:

This is the simplest of the Asymmetrical Windings. All Coils wound in the same direction But, MUST all be connected to the exactly opposite Commutator Element as stated in colors and arrows with the wires color codes to INPUT. This Motor is either ALL NORTH ROTOR POLES Or or ALL SOUTH ROTOR POLES. However, notice it delivers to G (OUT) Dual Coils Charge. while charging One Coil at Input. This Motor is very powerful, and delivers excellent outputs. Same config as all starting wires attach to one comm, and all ends of coils attach to other comm.

The Commutator brush marked "G" (for "Generator") takes away the energy stored in each coil and passes it to an electrical load. The Commutator brush marked "M" (for "Motor") feeds energy into the coil from the battery which is driving the motor. The red and blue stripes surrounding the armature are two permanent magnets. The magnet shown in red has it's South pole facing the armature and the magnet shown in blue has it's North pole facing the armature. This creates a magnetic field flowing horizontally across the armature. The five-pole arrangement is like this:

ASYMMETRIC FIVE POLE MOTOR

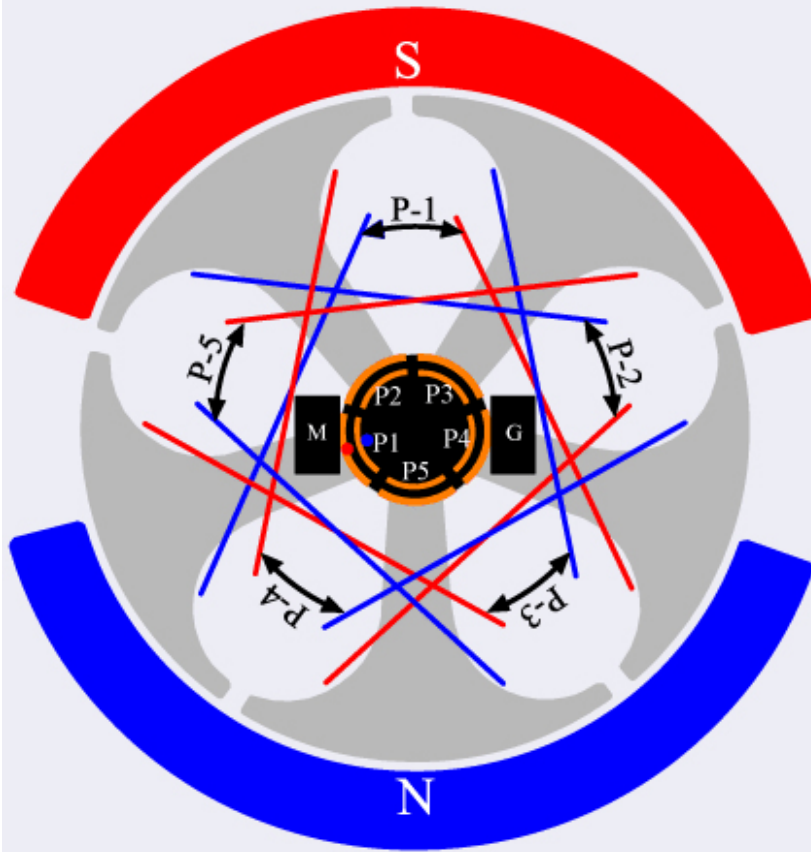

P1=Pairs of Coils Start Winding number one (1)
Blue -Red means projecting magnetic fields N/S outwards, towards Stators .
All Pairs of Coils wound in same direction of windings, just like winding One Coil.

All Coils must start from same commutator and all end at the other side commutator. Commutators-Elements must be perfectly aligned Upper and Lower.

Wire awg 30 (Red R/S Wire)

M Brush=Motor (Input)
G Brush=Generating Side (Output)

Here, the designation “R/S” stands for “Radio Shack” which is a chain of stores in America. In the forum, that is sometimes changed to “RS” and should not be confused with the large electronics outlet “Radio Spares” whose trademark is “RS”. UFOpolitics has suggested that the cheap 5-pole DC motor available from Radio Shack should be used by experimenters to become familiar with re-winding DC motor coils. Being a cheap product, those motors do not have a particularly high build quality, but they are suitable motors for experiments. Forum members share the details of how they dealt with adapting these and other motors.

I have to admit that motor windings and operation tend to confuse me and I sometimes find it difficult to understand what ‘UFOpolitics’ means when he talks about different winding strategies. However, it seems reasonably clear at this early stage of forum development, that his objective is to produce two things:

1. A very powerful electric motor which can be used in serious forms of road transport as well as for other practical applications, and
2. A powerful motor/generator combination which can produce useful generated electrical power.

While ‘UFOpolitics’ is very patiently going through many of the possible variations on how a DC motor can be wound and connected, and showing various forum members where they have failed to get some of their windings positioned correctly, he has also shown some of the best ways of connecting a re-wound motor used as a driver or “Prime Mover” as some people like to call it, and a re-wound motor which is to be used as an electrical generator. He shows two important ways for making a very effective Motor/Generator combination, as shown here:

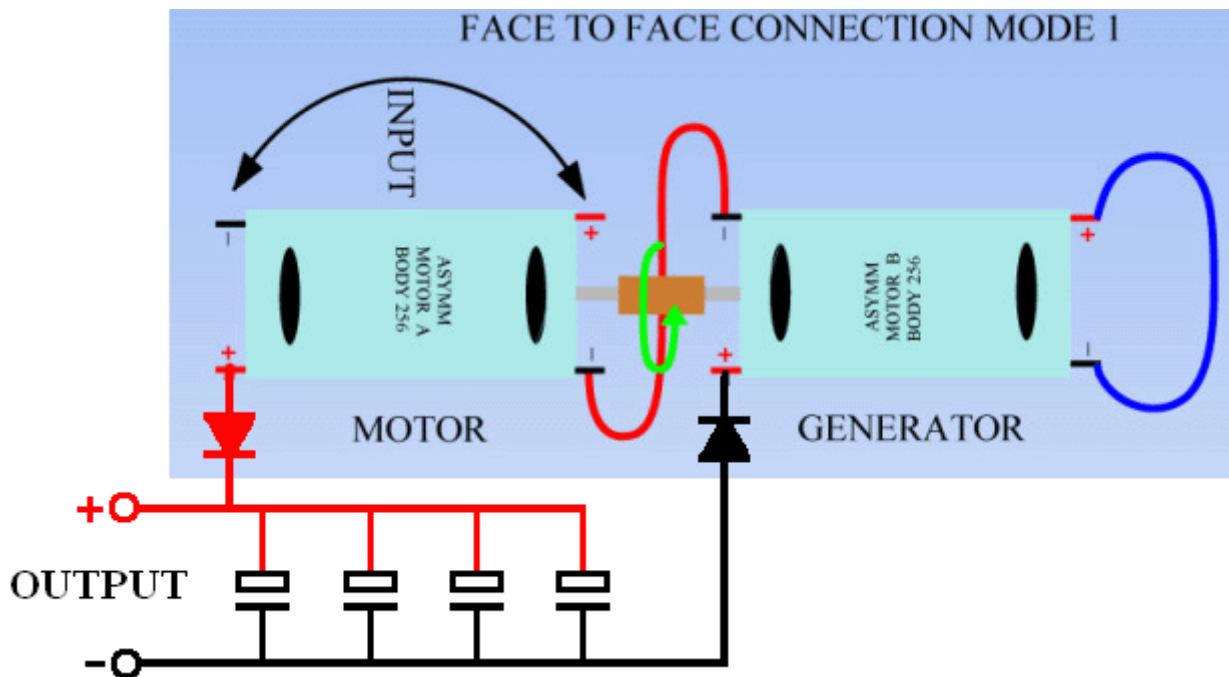

It needs to be realised that these arrangements are not conventional arrangements and that the re-wound motors operate in a different way to motors bought ‘off the shelf’. For this reason, it is necessary to isolate the electrical output to prevent current flowing through the load from affecting the operation of the Motor/Generator combination. This can be done by placing a diode in each of the output lines and charging a capacitor bank which is then used to feed whatever load is to be powered. If my understanding is correct, then feeding any cold electricity produced into a capacitor causes the current to become conventional hot electricity. It is not clear if that action is part of this arrangement although the circuitry shown should be used. This is the second version:

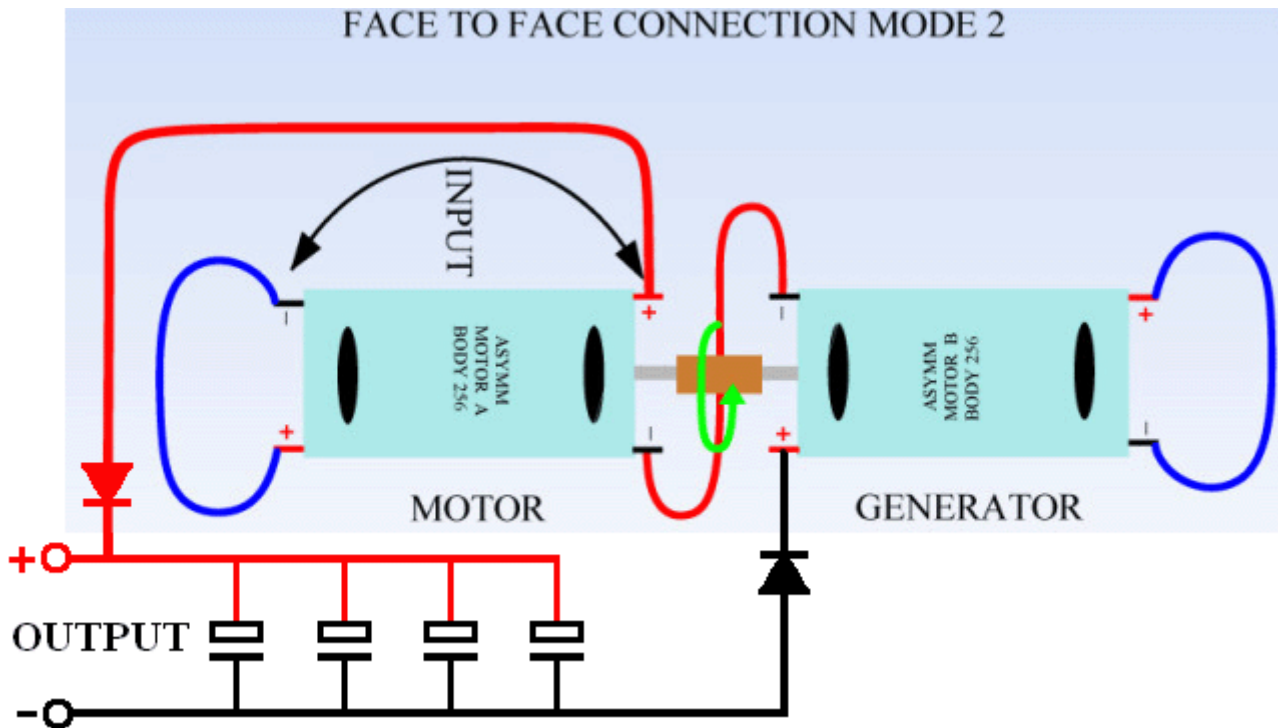

'UFOPolitics' comments on these arrangements as follows: As we excite the input of the Motor, the Generator will start producing energy and that additional energy will flow through the Motor Output side because they are connected in series here. Two rectifiers must be connected at both output terminals, Positive and Negative, to avoid back flow from closing the circuit through the load.

As the Motor accelerates, the Generator boosts the energy flow which then runs through the Motor augmenting the Output Fields and when the output is loaded then an 'Engagement' of both Machines occurs as they start to compensate each other through their output flows. It should be understood that the Output should be Capacitor Banked in a dedicated Reservoir.

When designing a Generator for a specific, existing Asymmetric Motor machine, it must be understood that Generator Interactions should be considered to run as "Counter Rotation" to the Motor Machine's originally conceived rotation (which is easily done by just moving brush-lines passing stator bisector angles to the opposite of those needed for a Motor, or alternatively, setting the timing backwards). This will definitively enhance the assisted rotation of both Machines when connected together in this Face-to-Face mode.

As I do not find the forum comments easy to understand, I recommend that you visit the forum and read the posts as you may well understand the conversations easier to follow than I do.

On the forum, 'Sanskara316' states "I have re-wound a small 3-volt 3-pole motor. I used an almost dead, 6-volt sealed lead-acid battery to power the motor. This battery just sits at around 4 volts and if given a load, even a small LED, it's voltage drops to 1 volt. The re-wound motor started very slowly - barely spinning, then after a minute or two it started to spin faster, and I noticed that the voltage on the battery was slowly climbing. I connected a small LED flashlight to the generating side and it lit up. Now the battery voltage under load is around 2+ volts. It's been running for an hour now and the machine squeals a lot. It is conditioning the battery and the meter cannot be showing what really is happening. The motor draws 300 ma?? – That's not possible as the battery just doesn't have that power". To which 'UFOPolitics' remarks: "Well I am glad you have witnessed some of the 'Effects'... these re-wound motors do recondition batteries...remember, Radiant Energy is taking over the Machine...so Radiant Energy comes out through the Input also... which is the reason why we get high Volts-Amps reading on a meter ...these motors use very small amounts of current and volts. Inside the motor, every coil is being 'Self-Electromagnetically-Pulsed' because they auto-disconnect from the power source, then the next coil in the sequence is assisted by the first coil when it has rotated to it's next position, and so on. The commutator switching has become a 'Self-Oscillator' for every independently-energised coil."

'prochiro' says: "I have also replicated the battery-charging events that 'Sanskara316' indicated. I started with a 12-volt 4 Amp-Hour battery which I had been using with another circuit two weeks ago and had not recharged it after using it for hours. It was sitting at 12.40 volts. I took my best-running re-wound motor, plugged it in direct and ran it. The battery voltage dropped to 12.24 volts and stayed at that level for 30 seconds. The battery voltage then started to rise 1/100 of a volt per minute. When it was at 12.27 volts, I disconnected the motor (the total run time was less than 5 minutes). I then let it rest for five minutes. At the end of the five minutes, the

battery voltage had risen to 12.43 volts and is still at that voltage now. Just think what a larger motor would do on a big battery bank. Everybody needs to document this test as it proves what 'UFOPolitics' said."

New DC motors, and particularly cheap motors, will have brushes which do not mate cleanly with the commutator slip ring sectors and so, when the modification has been made, running the motor for some time allows the brushes to wear in and that raises the efficiency of the electrical connections which in turn, improves the performance of the motor. If you wish to build and test one of these motors, then you can find help and support in the forum with your questions answered and numerous videos and photographs from different experimenters to help you.

Patrick Kelly

<http://www.free-energy-info.tuks.nl/>

Chapter 3: Motionless Pulsed Systems

The pulsed devices mentioned so far have had moving parts but rotating or fluctuating magnetic fields can be created without moving parts. An example of this is Graham Gunderson's solid-state electric generator shown in US Patent Application 2006/0163971 A1 of 27th July 2006 which is shown on page A-1038 of the appendix. Another example is:

Charles Flynn's Magnetic Frame.

Another device of this type comes from Charles Flynn. The technique of applying magnetic variations to the magnetic flux produced by a permanent magnet is covered in detail in the patents of Charles Flynn which are included in the Appendix. In his patent he shows techniques for producing linear motion, reciprocal motion, circular motion and power conversion, and he gives a considerable amount of description and explanation on each, his main patent containing a hundred illustrations. Taking one application at random:

He states that a substantial enhancement of magnetic flux can be obtained from the use of an arrangement like this:

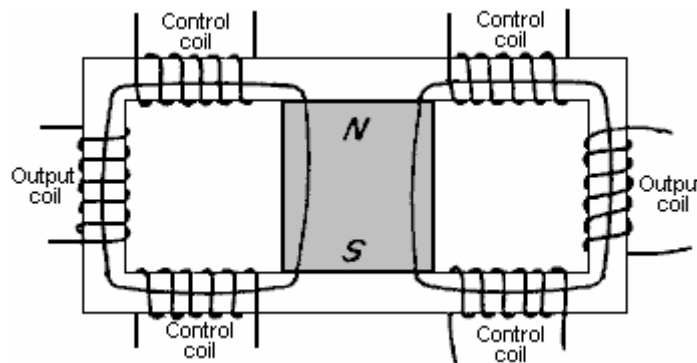

Here, a laminated soft iron frame has a powerful permanent magnet positioned in it's centre and six coils are wound in the positions shown. The magnetic flux from the permanent magnet flows around both sides of the frame.

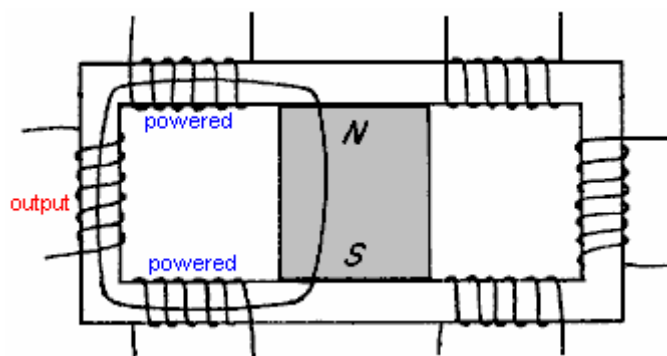

The full patent details of this system from Charles Flynn are in the Appendix, starting at page A - 338.

Lawrence Tseung's Magnetic Frame.

Lawrence Tseung has recently produced a subtle design using very similar principles. He takes a magnetic frame of similar style and inserts a permanent magnet in one of the arms of the frame. He then applies sharp DC pulses to a coils wound on one side of the frame and draws off energy from a coil wound on the other side of the frame.

He shows three separate operating modes for the devices as follows:

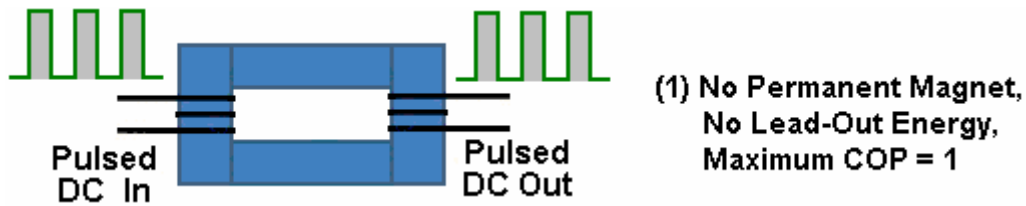

Lawrence comments on three possible arrangements. The first one shown above is the standard commercial transformer arrangement where there is a frame made from insulated iron shims in order to cut down the "eddy" currents which otherwise would circulate around inside the frame at right angles to the useful magnetic pulsing which links the two coils on the opposite sides of the frame. As is very widely known, this type of arrangement never has an output power greater than the input power.

However, that arrangement can be varied in several different ways. Lawrence has chosen to remove a section of the frame and replace it with a permanent magnet as shown in the diagram below. This alters the situation very considerably as the permanent magnet causes a continuous circulation of magnetic flux around the frame before any alternating voltage is applied to the input coil. If the pulsing input power is applied in the wrong direction as shown here, where the input pulses generate magnetic flux which opposes the magnetic flux already flowing in the frame from the permanent magnet, then the output is actually **lower** than it would have been without the permanent magnet.

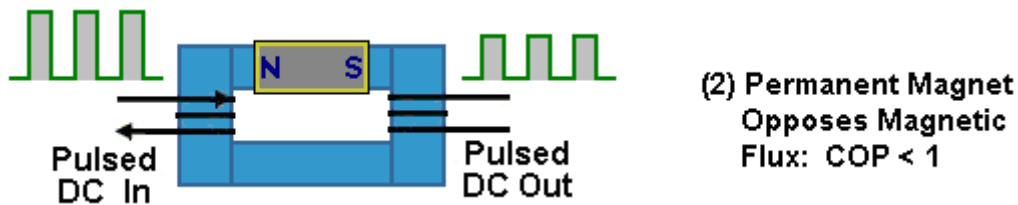

However, if the input coil is pulsed so that the current flowing in the coil produces a magnetic field which reinforces the magnetic field of the permanent magnet then it is possible for the output power to exceed the input power. The "Coefficient of Performance" or "COP" of the device is the amount of output power divided by the amount of input power which the user has to put in to make the device operate. In this instance the COP value can be greater than one:

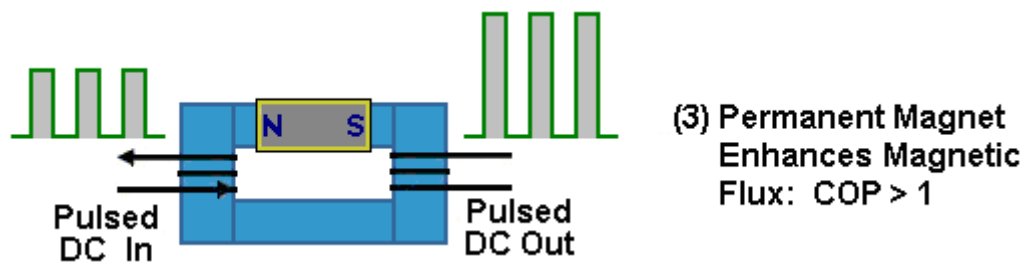

As it upsets some purists, perhaps it should be mentioned that while a square wave input signal is applied to the input of each of the above illustrations, the output will not be a square wave although it is shown that way for clarity. Instead, the input and output coils convert the square wave to a low-quality sine wave which only becomes a pure sine wave when the pulse frequency exactly matches the resonant frequency of the output winding. The oscilloscope display shown here is a typical output power waveform which has nearly 390,000 of these pulses per second.



There is a limit to this as the amount of magnetic flux which any particular frame can carry is determined by the material from which it is made. Iron is the most common material for frames of this type and it has a very definite saturation point. If the permanent magnet is so strong that it causes saturation of the frame material before the input pulsing is applied, then there can't be any effect at all from positive DC pulsing as shown. This is just common sense but it makes it clear that the magnet chosen must not be too strong for the size of the frame, and why that should be.

As an example of this, one of the people replicating Lawrence's design found that he did not get any power gain at all and so he asked Lawrence for advice. Lawrence advised him to omit the magnet and see what happened. He did this and immediately got the standard output, showing that both his input arrangement and his output

measuring system both worked perfectly well. It then dawned on him that the stack of three magnets which he was using in the frame were just too strong, so he reduced the stack to just two magnets and immediately got a performance of COP = 1.5 (50% more power output than the input power).

The Transformers of Thane Heins.

Thane has developed, tested and patented a transformer arrangement where the output power of his prototype is thirty times greater than the input power. He achieves this by using a figure-of-eight double toroid transformer core. His Canadian patent CA2594905 is titled "Bi-Toroid Transformer" and dated 18th January 2009. The abstract says: The invention provides a means of increasing transformer efficiency above 100%. The transformer consists of a single primary coil and two secondary coils. The two secondary coils are set on a secondary toroidal core which is designed to be maintained at a lower magnetic resistance than the primary toroidal core throughout the entire operating range of the transformer. Thus, when the transformer secondary delivers current to a load, the resulting Back-EMF is not allowed to flow back to the primary due to the higher magnetic resistance of that flux path, instead, the secondary coil's Back-EMF follows the path of least magnetic resistance into the adjacent secondary coil.

You will notice that in the following diagram, the secondary transformer frame on the right is much larger than the primary transformer frame on the left. This larger size produces a lower magnetic resistance or "reluctance" as it is known technically. This seems like a minor point but in fact it is not, as you will see from the test results.

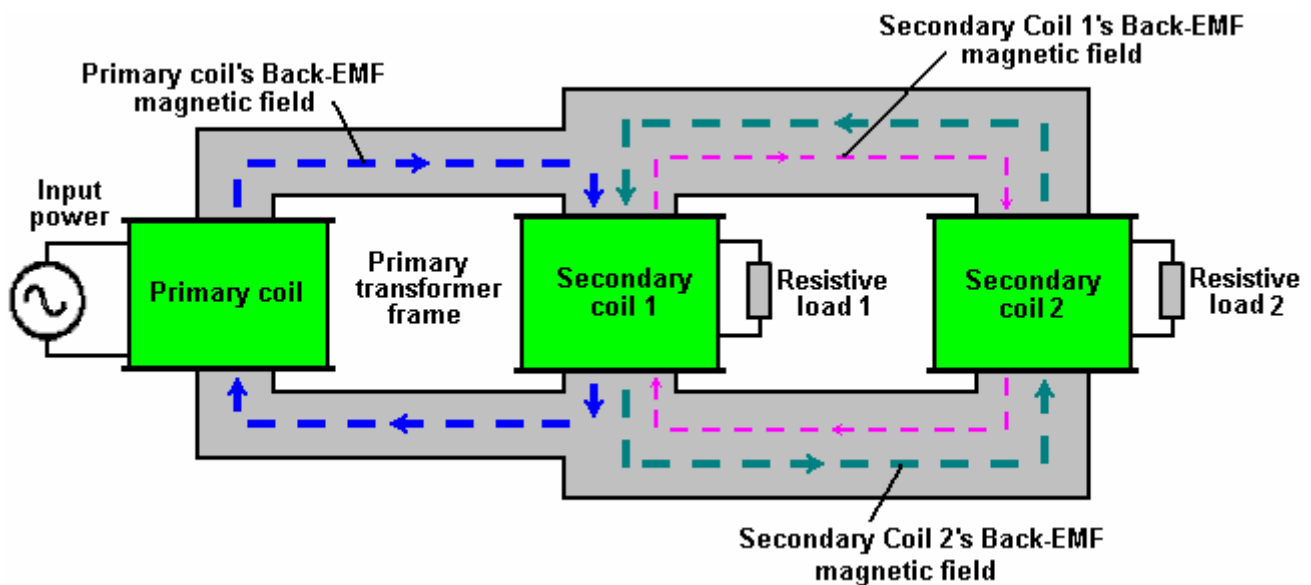

In a conventional transformer, the power flowing in the primary winding induces power in the secondary winding. When the power in the secondary winding is drawn off to do useful work, a Back-EMF magnetic flux results and that opposes the original magnetic flux, requiring additional input power to sustain the operation.

In this transformer, that opposing magnetic flux is diverted through a larger magnetic frame which has a much lower resistance to magnetic flow and which, as a result, bleeds off the problem flux, sending it through secondary coil 2 in the diagram above. This pretty much isolates the input power from any opposition, resulting in a massive improvement in the operation efficiency.

In the patent document, Thane quotes a prototype test which had a primary coil winding with 2.5 ohms resistance, carrying 0.29 watts of power. The secondary coil 1 had a winding with 2.9 ohms resistance, receiving 0.18 watts of power. The Resistive load 1 was 180 ohms, receiving 11.25 watts of power. The secondary coil 2 had a winding with 2.5 ohms resistance, and received 0.06 watts of power. Resistive load 2 was 1 ohm, receiving 0.02 watts of power. Overall, the input power was 0.29 watts and the output power 11.51 watts, which is a COP of 39.6 and while the document does not mention it directly, the primary coil should be driven at its resonant frequency.

A variation of this arrangement is to attach an outer toroid to the existing bi-toroid arrangement, like this:



This prototype, as you can see, is fairly simple construction, and yet, given an input power of 106.9 milliwatts, it produces an output power of 403.3 milliwatts, which is 3.77 times greater.

This is something which needs to be considered carefully. Conventional science says that "there is no such thing as a free meal" and with any transformer, you will get less electrical power out of it than you put into it. Well, this simple looking construction demonstrates that this is not the case, which shows that some of the dogmatic statements made by present day scientists are completely wrong.

This version of Thane's transformer is made like this:

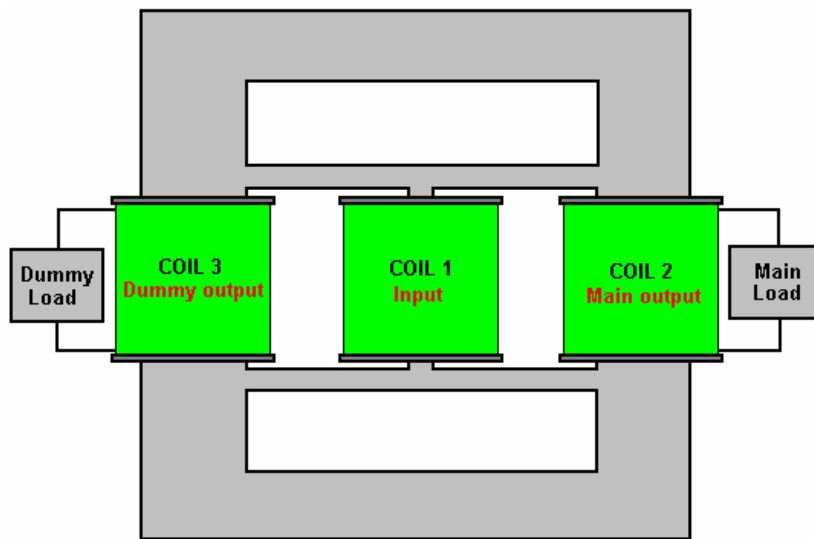

The way that off-the-shelf transformers work at the moment is like this:

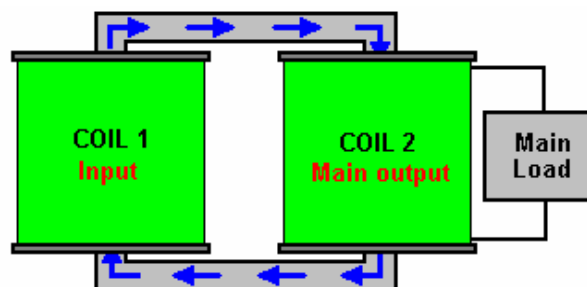

When a pulse of input power is delivered to Coil 1 (called the "Primary winding"), it creates a magnetic wave which passes around the frame or "yoke" of the transformer, passing through Coil 2 (called the "Secondary winding") and back to Coil 1 again as shown by the blue arrows. This magnetic pulse generates an electrical output in Coil 2, which flows through the electrical load (lighting, heating, charging, video, or whatever) providing it with the power which it needs to operate.

This is all well and good but the catch is that the pulse in Coil 2 also generates a magnetic pulse, and unfortunately, it runs in the opposite direction, opposing the operation of Coil 1 and causing it to have to boost it's input power in order to overcome this backward magnetic flow:

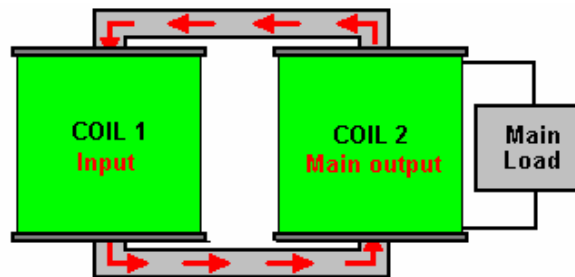

This is what makes current scientific "experts" say that the electrical efficiency of a transformer will always be less than 100%.

Thane has overcome that limitation by the simple and elegant technique of diverting that backward pulse of magnetism and channelling it through an additional magnetic path of lower resistance to magnetic flow through it. The path is arranged so that Coil 1 has no option but to send it's power through the frame as before, but the return pulse takes a much easier path which does not lead back to Coil 1 at all. This boosts the performance way past the 100% mark, and 2,300% has been achieved quite readily (COP=23). The additional path is like this:

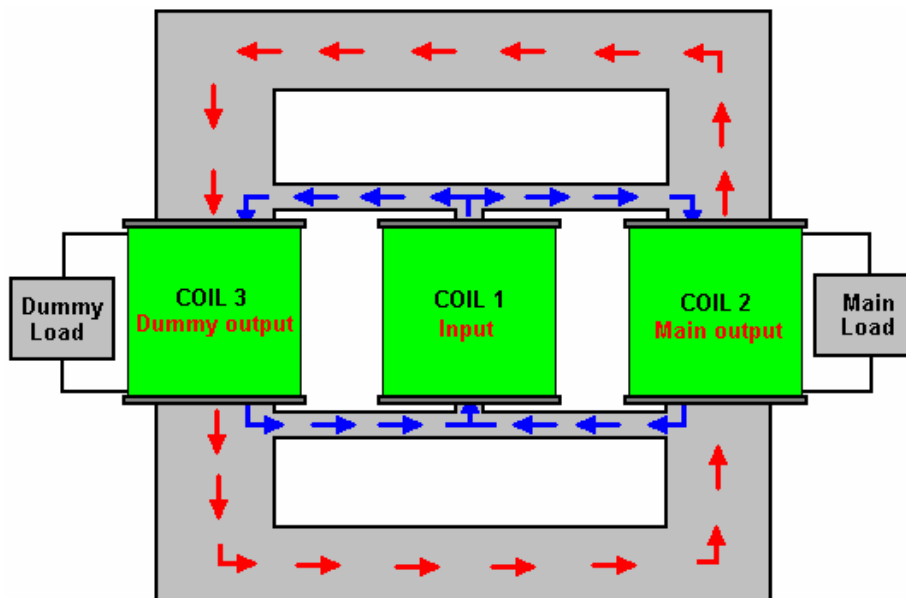

Not shown in this diagram are the reverse pulses from Coil 3. These follow the easier outside path, opposing the unwanted back pulse from coil 2. The overall effect is that from Coil 1's point of view, the tiresome back pulses from Coil 2 have suddenly disappeared, leaving Coil 1 to get on with the job of providing power without any hindrance.

This simple and elegant modification of the humble transformer, converts it into a free-energy device which boosts the power used to drive it and outputs much greater power. Congratulations are due to Thane for this technique.

At the present time there are videos showing how this transformer works:

<http://www.youtube.com/watch?v=5KfwiXJ8apk> and

<http://www.youtube.com/watch?v=GcAYhMOLX9A&playnext=1&feature=sub&list=TLJwIILxS9jQ>.

Combining Magnetic Frames

This is just a suggestion and has not been built and tested. First, watch the very interesting video at: http://www.youtube.com/watch?v=sTb5g9o8F8c&list=UUaKHAdY13gp-un2hn_HJehg&index=1&feature=plcp where it appears that a ferrite toroid with small magnets on it is one way to reproduce Lawrence Tseung's magnetic frame:

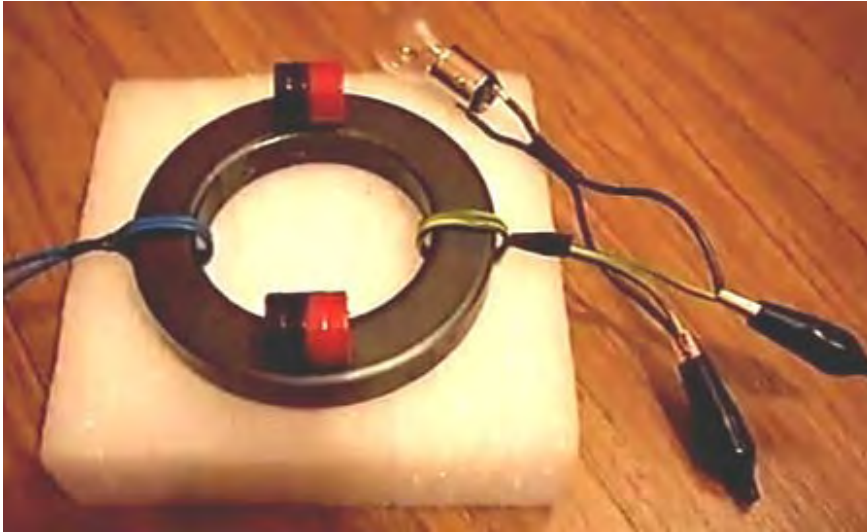

While this would be a very easy video to fake, considering the Tseung frame performance, I am inclined to accept this one at face value. The Tseung Magnetic frame has been independently replicated at COP=1.5 which is, 50% more power output than the input power.

One obvious arrangement to test is cascade frames as shown here:

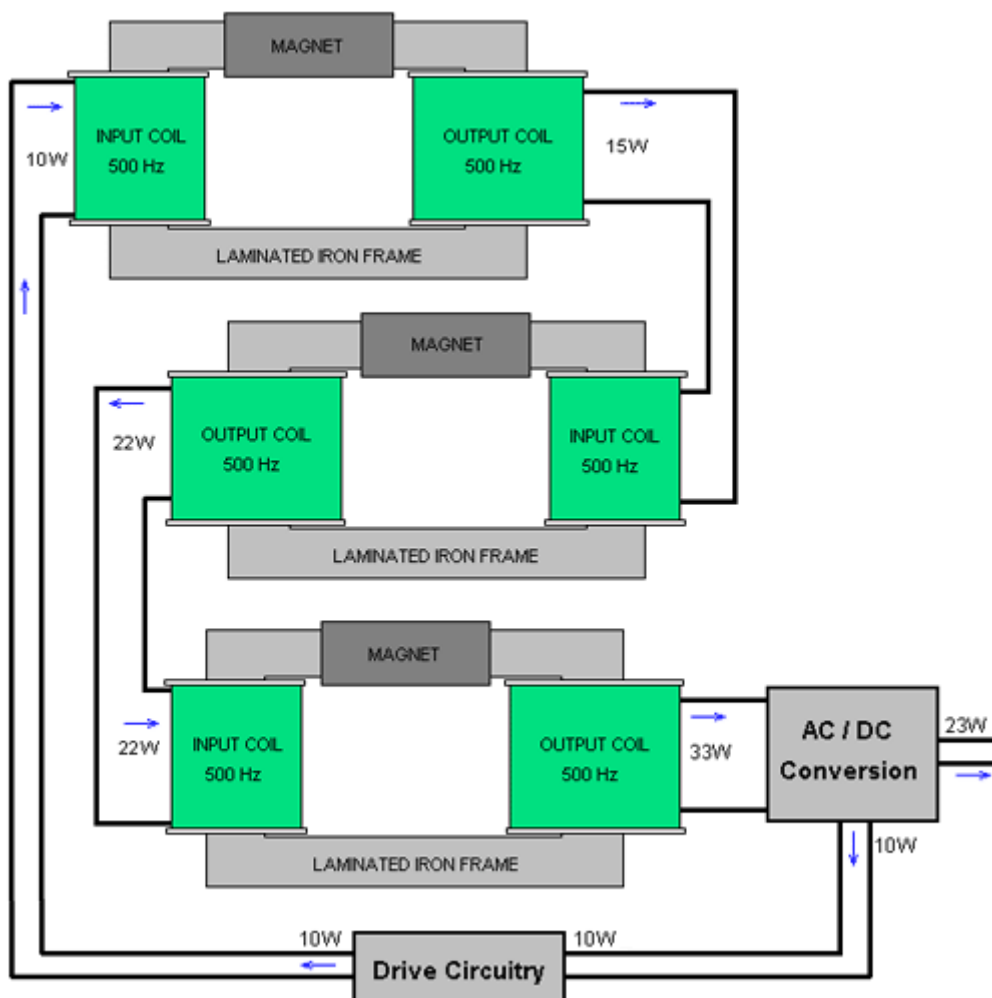

The limit here is the magnetic saturation of the laminated frames or "yokes". While you can do all sorts of calculations to predict what power levels can be carried by any laminated iron frame, all that is really necessary is to look at an existing transformer and see what power rating is quoted for that particular frame cross-section size, and although the power levels shown in the diagram are very modest, it is likely that very much higher power levels could be used, giving a much higher excess output.

Laminated iron has very restricted operating frequency, typically, well below 1000 Hz, which is why the diagram above shows just 500 Hz as the suggested frequency. As efficiency improves at higher frequencies, using ferrite for the frame and a higher frequency should improve the performance.

One additional step would be to use Thane Heins' adaption for the frames as his performance gain is very much better with 300% being about the lowest noted in experiments. Combining these two ideas might produce an arrangement like this:

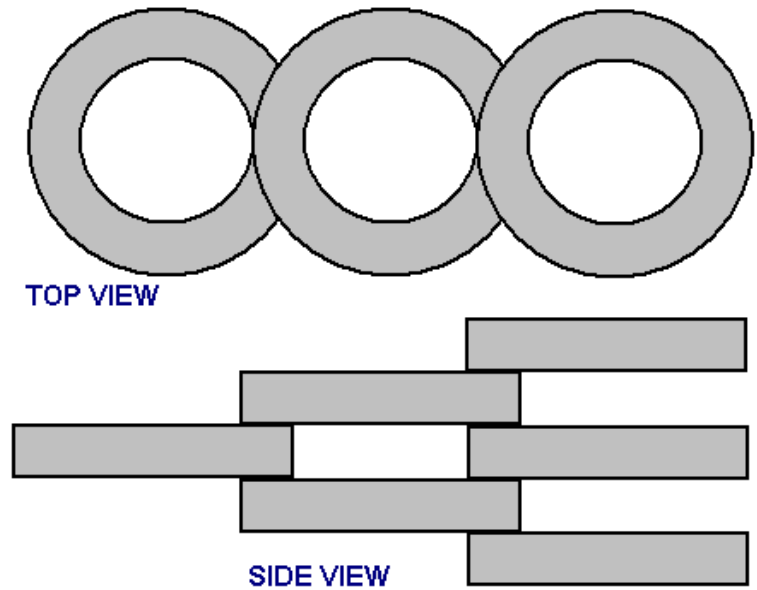

With this arrangement, the increased magnetic path on the right hand side of the first two toroids gives a dramatic improvement to their performance, even without the use of magnets on the toroids. A COP of nine or more should be perfectly possible, but only actual implementation and testing will show the real performance and testing far outweighs theory and ideas. Wound with coils, the arrangement would look like this:

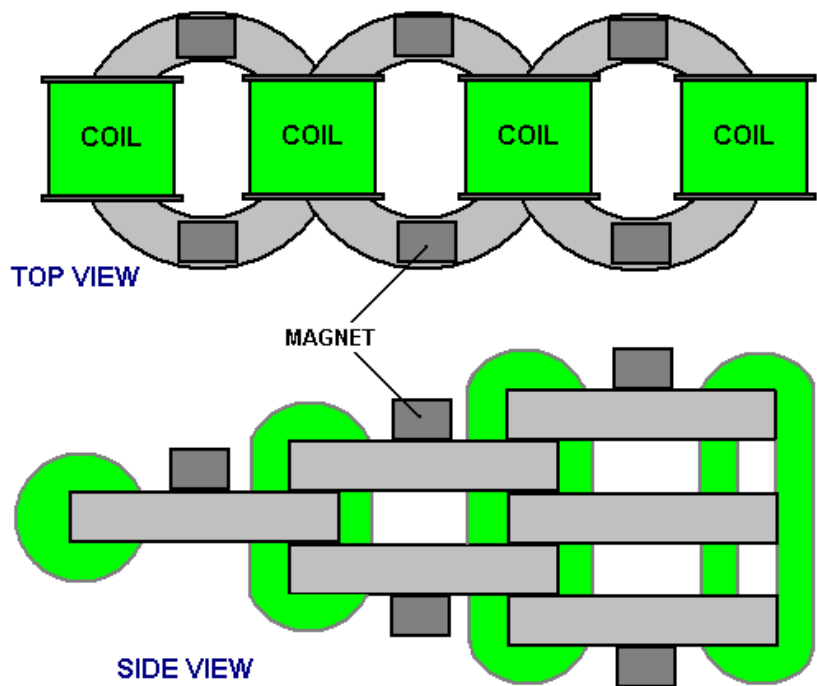

The input would be pulsed with a 555 timer circuit or a signal generator. Power limit is the magnetic saturation

point of the toroids as you have to keep below magnetic saturation or else your pulsing will not have any effect. Avoid the resonant frequency of the ferrite toroids, but pulsing in the kilohertz range might give a very good results. There is, of course, no reason why you could not use more than one of those arrangements, combining the outputs after rectification and feeding into a capacitor:

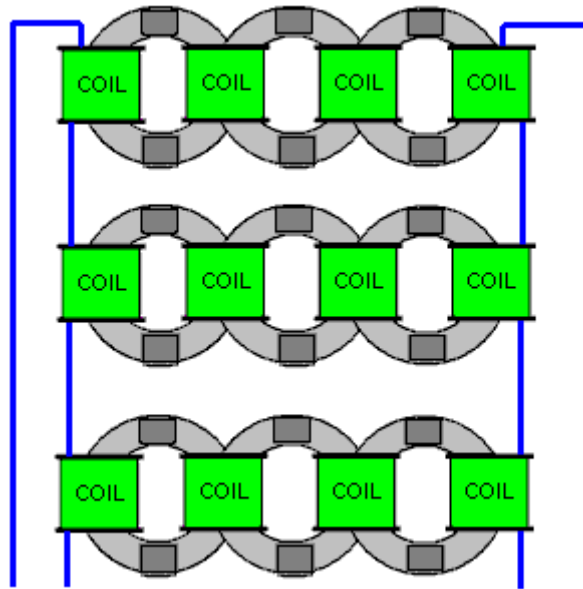

This could be an interesting project. You will notice in the video that the brightest light is where the second magnet has not been turned around all the way to where the demonstrator finally positions it, so experimenting with different magnet angles might produce better effects. The magnets can be held in place with super glue when the best positions have been found.

While the brilliant dual-toroid technique of Thane Heins is very effective, it is not the only way of achieving spectacular performance from a transformer as can be seen here:

The High-power Motionless Generator of Clemente Figuera

Clemente Figuera of the Canary Islands died in 1908. He was a highly respected individual, an Engineer and University Professor. He was awarded several patents and was known to Nikola Tesla. Figuera's design is very simple in outline. He has avoided the performance-killing Lenz Law magnetic feedback by splitting a transformer into three parts. Two parts form the primary winding and are shown on the left and on the right. The third part is the secondary winding which is located in the centre. Because of the splitting of the primary into two parts, Lenz's Law has been abolished for this design, allowing a spectacular performance where the current drawn from the secondary winding has no effect on the current flowing in the two halves of the primary winding. There is also, no back-EMF as current flows continuously in both halves of the primary winding. The very clever method used by Clemente makes the strength of the current in the two halves of the primary to oscillate with one side repeatedly having first much more current and then far less current than the other half. This generates alternating current in the secondary, current which can be drawn off and used for useful work, powering lights, heaters, motors, etc. The following information comes from a man who wishes to remain anonymous. On 30th October 2012, he made the following comments about his repair to a Figuera patent which was missing some of the content. He says:

CLEMENTE FIGUERA AND HIS INFINITE ENERGY MACHINE

I heard of Clemente Figuera for the first time from one of the Tesla articles. In 1902 the Daily Mail announced that Mr. Figueras (with an "s"), a Forestry Engineer in the Canary Islands, and for many years Professor of Physics at St. Augustine's College, Las Palmas, had invented a generator which required no fuel. The newspaper article says that "He claims to have invented a generator which can collect the electric fluid, to be able to store it and apply it to infinite purposes, for instance, in connection with shops, railways and manufacturers. He will not give the key to his invention, but declares that the only extraordinary point about it is that it has taken so long to discover a simple scientific fact. Señor Figueras has constructed a rough apparatus by which, in spite of it's small size and it's defects, he obtains 550 volts, which he utilises in his own house for lighting purposes and for driving a 20 horse-power motor. Señor Figueras is shortly coming to London, not with models or sketches, but with a working apparatus. His inventions comprise a generator, a motor, and a sort of

governor or regulator, and the whole apparatus is so simple that a child could work it." [Taken from "Perpetual Motion – A History of an Obsession"].

I was in one of the forums when someone mentioned Clemente Figuera and provided some links to documents referring to his work [1]. In one of the documents, I found what looks to be the only page showing sketches from one of his patents. After restoring the faint lines which show the wire connections, I was very surprised to see the similarities between the embodiment of Mr. Figuera's drawing and one of my own for over-unity transformers.

I was very eager to read any information about Mr Figuera's work and the operation of his 'Infinite Energy Machine'. It looks very suspicious that the pages describing the most important part of the machine have been 'lost'. I then decided to just figure this machine out for myself.

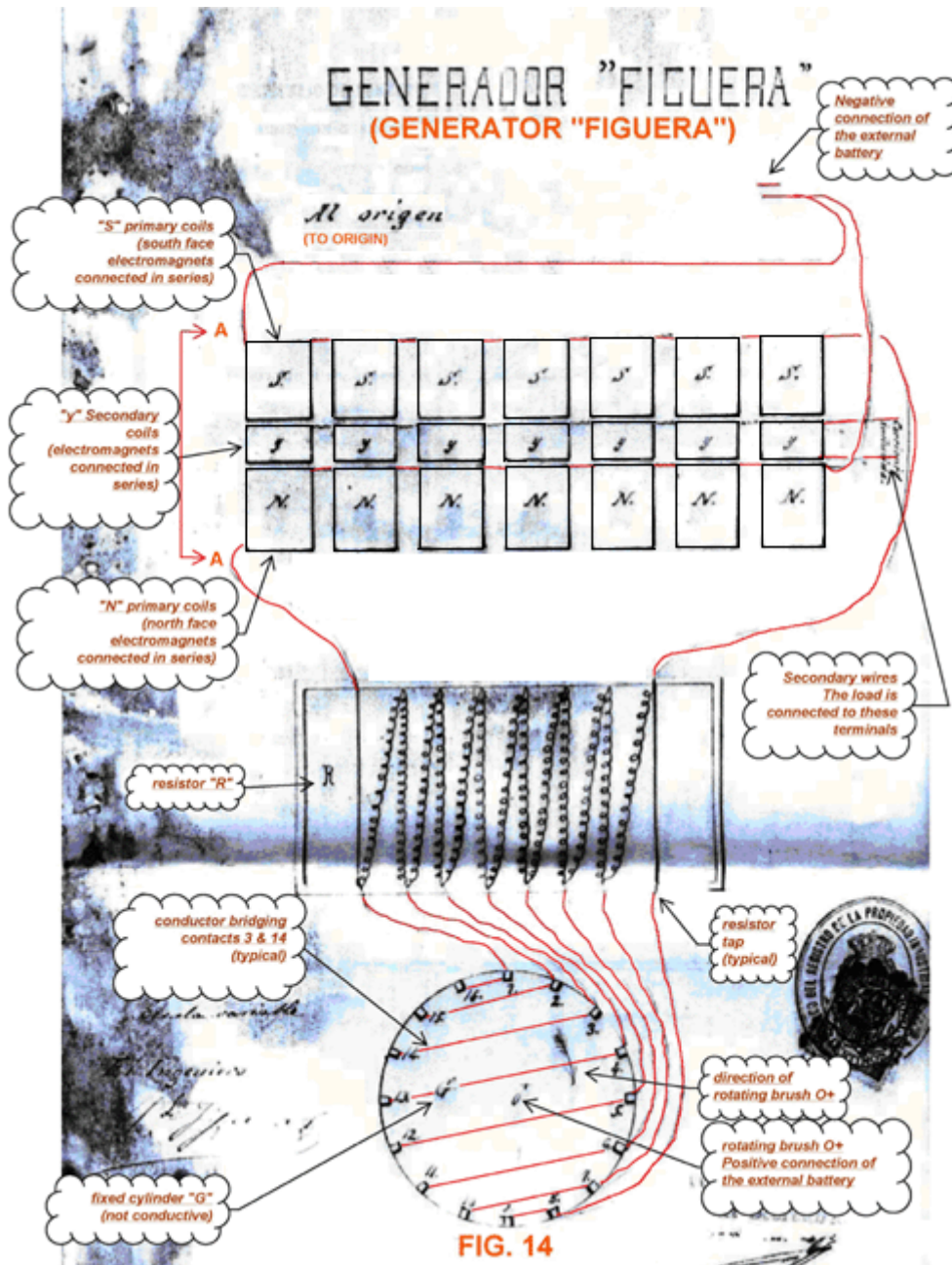

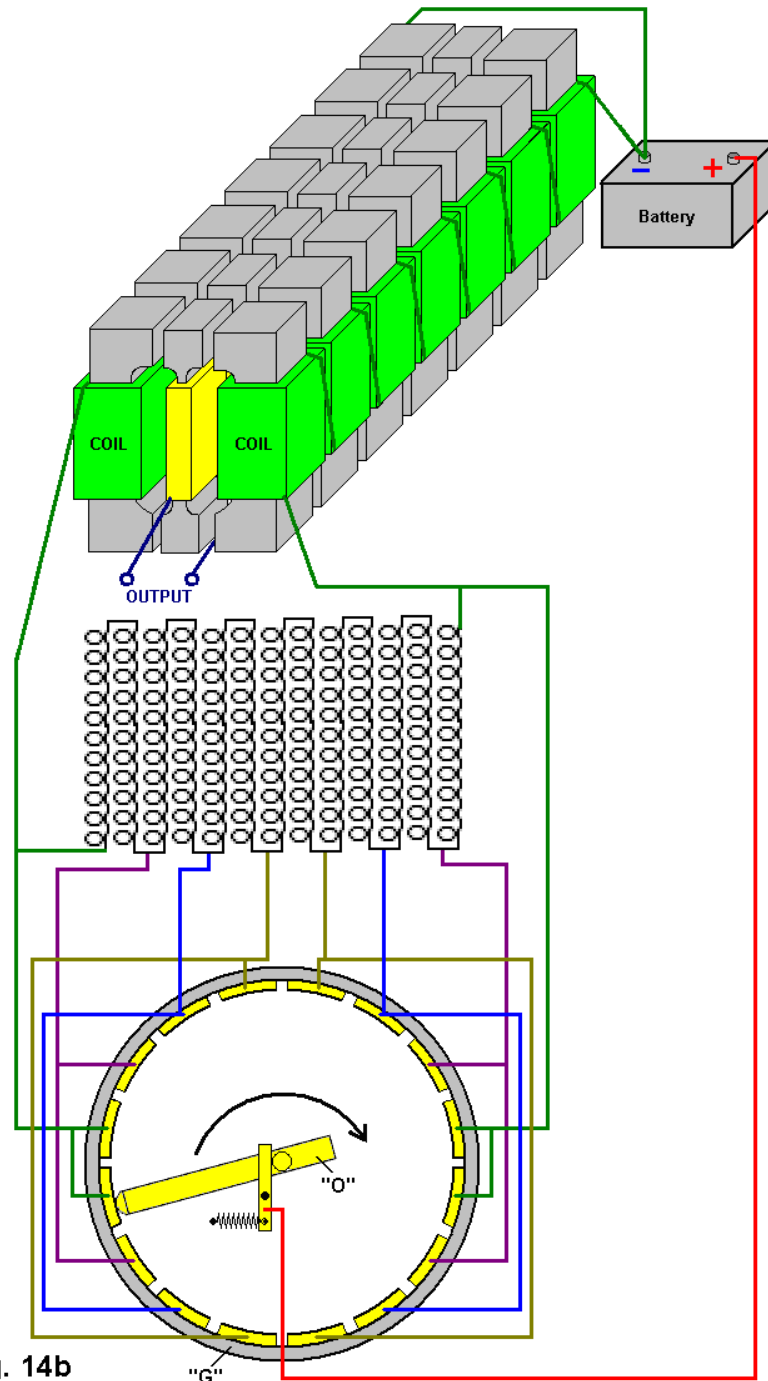

Fig. 14b

Please note that the rotating contact brush needs to be a "Make Before Break" type. That is, it needs to bridge across the gap between adjacent stator contact strips so that there is no sparking due to the current flow being interrupted.

According to Mr. Figuera, an over-unity transformer can be built without using permanent magnets, and based on a very simple concept. Figuera's generator consists of three rows of electromagnets, where each row is connected in series. The rows of "S" and "N" electromagnets function as the primary of the transformer, while the row of "y" electromagnets, located in the centre, functions as the secondary. The "S" and "N" stand for South and North poles, respectively. The apparatus includes a resistor "R" having multiple taps connected to a type of distributor formed by a cylinder "G" and brush "O". The brush "O" rotates inside the cylinder "G" changing the connection to the resistor taps. When the brush "O" rotates around the eight taps, it generates two stepped half-cycle sine waves which are 90° out of phase with each other. I suggest that Fig.15 is the wiring diagram as originally disclosed by Mr. Figuera in his patents. The most significant component of the system is the arrangement of the electromagnets shown in section A-A of figure 14. Keep in mind that each electromagnet shown in figure 15 corresponds to a row of seven electromagnets connected in series as shown in figure 14. In addition, I recommend that when building this apparatus, at least for the first implementation, that you try to replicate all of the details of the device shown in the patent. For example, figure 14 shows the top area of the "S" and "N" electromagnets being approximately equal to twice the top area of the "y" electromagnets.

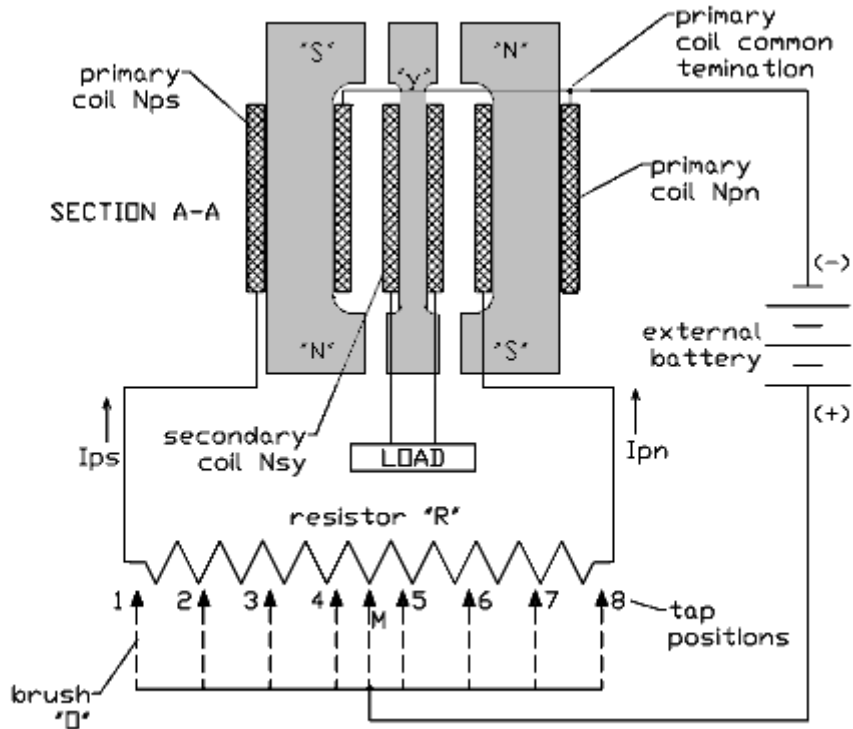

FIG. 15.

SIDE VIEW

Even though Mr. Figuera used stepped sinusoidal currents I_{ps} and I_{pn} , I consider the resistor shown in Fig.15, to be a linear variable resistor having infinite 'taps' and the voltage and current generated to be pure half-cycle sine waves which are 90° out of phase. The coils of the "S" and "N" electromagnets are connected together and attached to the negative terminal of the battery. The other ends of both electromagnets are connected to both ends of the resistor "R". The sliding contact "O" is connected to the positive terminal of the battery and is rotated continuously making electrical connections repeatedly from left to right and then back from right to left across the multi-tap resistor "R". The position of the sliding contact "O", determines the magnitude of the DC currents I_{ps} and I_{pn} passing through the primary coils "S" and "N". For instance, when the brush is in position 1, the "S" coils receive the full voltage of the battery, producing the maximum current I_{ps} and maximum magnetic field B_{ps} , while at the same time, the current I_{pn} and magnetic field B_{pn} of the "N" coils are at their minimum values because they are now connected to the battery through the maximum value of the resistor "R". Figure 21 shows the voltage, current, and magnetic field waveforms flowing through these coils. The voltage induced in the secondary coils "y" is a sinusoidal alternating voltage. The secondary voltage should be zero when the magnitudes of the currents I_{ps} and I_{pn} are equal. At this point, the magnetic fields B_{ps} and B_{pn} induce two voltages of the same magnitude and opposite polarity.

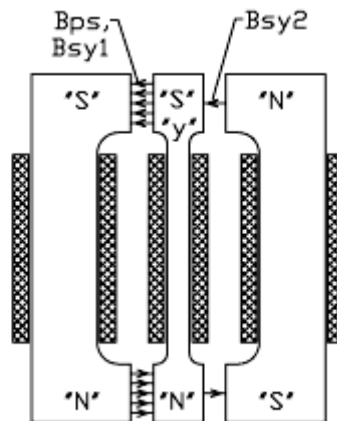

FIG. 16.

POSITION 1

The magnetic interaction of the "S", "N", and "y" electromagnets is shown in Fig.16 to Fig.20. Figure 16 illustrates the situation when the brush "O" is at position 1. Here, the current I_{ps} and magnetic field B_{ps} are at their maximum, while the current I_{pn} and magnetic field B_{pn} are at their minimum values. When the secondary current I_{sy} starts flowing, the "y" coils generate a magnetic field B_{sy} which opposes the magnetic field B_{ps} in accordance with Lenz's law. As a consequence, a South pole is created at the top of the "y" electromagnet and a

North pole at the bottom. Because magnets of the same polarity repel and opposite polarities attract, it is likely that some of the induced magnetic field B_{sy2} is diverted through the iron core of the "N" electromagnet, which represents a lower reluctance path. And, if the induced magnetic field B_{sy} can be rerouted so as to avoid opposing the magnetic field B_{ps} which generates it, then, it might be possible to have an over-unity transformer.

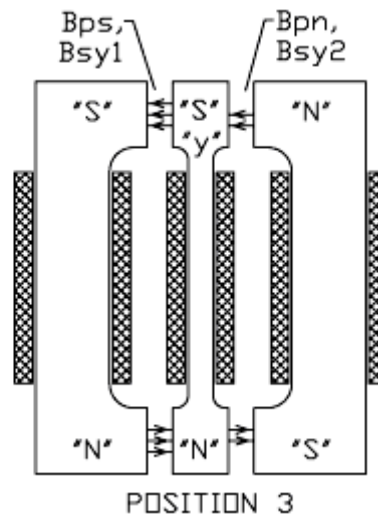

FIG. 17

POSITION 3

Fig.17 illustrates the situation when the sliding contact "O" is at position 3. The primary current I_{ps} and the primary magnetic field B_{ps} are decreasing in magnitude while the magnitude of the primary current I_{pn} and magnetic field B_{pn} are both increasing. The primary current I_{ps} (and B_{ps}) is still larger than primary current I_{pn} (and B_{pn}). As shown in the figure, part of the induced magnetic field B_{sy2} is still coupled to the "N" electromagnets.

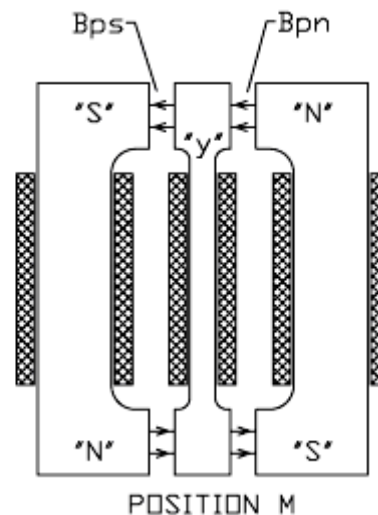

FIG. 18

POSITION M

Fig.18 illustrates the scenario when the brush is at position M. This position is exactly at the centre of the resistor "R" and both currents I_{ps} and I_{pn} are of equal magnitudes, and as a result, the magnetic fields B_{ps} and B_{pn} are also equal. The net voltage V_{sy} , current I_{sy} , and magnetic field B_{sy} induced in the secondary coils "y" are all zero.

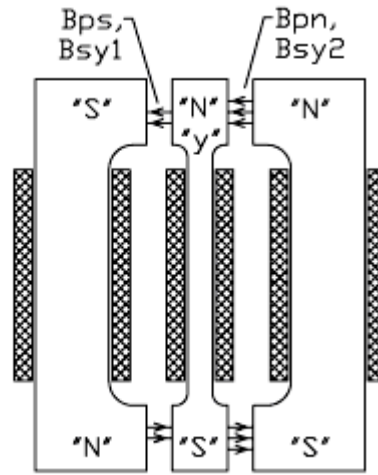

FIG. 19

POSITION 6

Figure 19 shows the situation when sliding contact “O” is at position 6. The primary current I_{ps} and the primary magnetic field B_{ps} are still decreasing in magnitude while the magnitude of the primary current I_{pn} and the magnetic field B_{pn} are increasing. The primary current I_{ps} (and B_{ps}) is now of lower magnitude than primary current I_{pn} (and B_{pn}). Because the magnetic field B_{pn} of the “N” electromagnets is stronger than the magnetic field B_{ps} of the “S” electromagnets, the polarity of the induced voltage V_{sy} , current I_{sy} , and magnetic field B_{sy} are reversed in accordance with Lenz’s law. In this situation, the secondary electromagnets “y” present the north poles at the top and the south poles at the bottom making the “y” and “N” electromagnets to repel and the “y” and “S” to attract. Because of the now higher reluctance of the “N” electromagnets and lower reluctance of the “S” electromagnets, it is expected that part of the induced magnetic field B_{sy} will couple with the “S” electromagnets, and therefore, the effect of Lenz’s law is minimised.

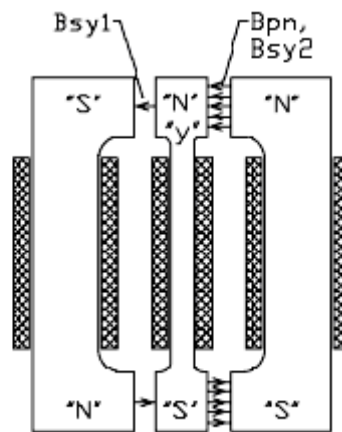

FIG. 20

POSITION 8

Fig.20 illustrates the situation when the brush “O” is at position 8. The primary current I_{pn} and the magnetic field B_{pn} are at their maximum values. The induced secondary voltage V_{sy} , current I_{sy} , and magnetic field B_{sy} are also maximum and of opposite polarities to those which they had at position 1. Again, part of the induced secondary magnetic field B_{sy} is attracted by the “S” electromagnet mitigating the effect of Lenz’s law.

References:

- [1] <http://orbo.es/>
http://www.bibliotecapleyades.net/tesla/esp_tesla_27.htm
http://www.alpoma.net/tecob/?page_id=8258

Our thanks are due to the anonymous contributor who produced the above information on the work of Clemente Figuera whom I had never heard of before. Recently, the forum member ‘hanlon1492’ of the overunity.com forum http://www.overunity.com/12794/re-inventing-the-wheel-part1-clemente_figuera-the-infinite-energy-machine/#.UXu9gzcQHqU has shared a translation of Figuer’s complete 1908 patent, lodged just days before he died, and it is reproduced here with thanks to ‘hanlon1492’ for his work and for freely sharing the results:

PATENT by CLEMENTE FIGUERA (year 1908) No. 44267 (Spain)

Ministry of Development General Board of Agriculture, Industry and Commerce. Patents of Invention. Expired. Dossier number 44267. Instruction at the request of D. Clemente Figuera. Representative Mr. Buforn. Presented in the register of the Ministry in the 31st October 1908, at 11:55 received in the negotiated in the 2nd November 1908.

ELECTRICAL GENERATOR "FIGUERA"

BACKGROUND

If we rotate a closed circuit inside a spinning magnetic field, with the closed circuit positioned at right angles to the lines of magnetic force, a current will be induced in the closed circuit for as long as there is movement, and the sign of that induced current will depend on the direction in which the closed circuit moves.

This is the basis of all magnetic machines and electric dynamos from the original, invented by Pixii, in France and later modified and improved by Clarke to reach the design of the current dynamos of today.

The principle on which this theory is based, has the unavoidable need for the movement of either the induction circuit or the magnetic circuit, and so, these machines are considered to be a transformer of mechanical work into electricity.

PRINCIPLE OF THE INVENTION

Considering carefully what happens in a dynamo in motion, we see that the coil turns of the induction circuit approach and move away from the magnetic centres of the magnets or electromagnets, and those turns, while spinning, pass through sections of the magnetic field of different magnetic strengths, because, while the maximum magnetic strength is in the centre of the core of each electromagnet, this action weakens as the induction coil moves away from the centre of the electromagnet, only to increase again when it is approaching the centre of another electromagnet with opposite sign to the first one.

Because we all know that the effects seen when a closed circuit approaches and moves away from a magnetic centre are the same as when the circuit is motionless and the magnetic field increased and decreased in intensity, since any variation of the magnetic flow traversing a circuit produces an induced electrical current. Then, consideration was given to the possibility of building a machine which would work, based, not on the principle of movement as current dynamos do, but based on the principle of increasing and decreasing the strength of the magnetic field, or the strength of the electrical current which produces it.

The voltage from the total current of the current dynamos is the sum of all of the induced currents generated in every turn of the induction coils. Therefore it does not matter if these induced currents were generated by rotating the induction coils, or by varying the magnetic flux which passes through them. In the first case, a greater amount of mechanical work is required than the amount of electricity generated, while in the second case, the force needed to produce the variation of magnetic flux is so insignificant that it can easily be taken from the output generated by the machine.

Up to the present day, no machine based on this principle has been constructed for the production of large electrical currents, and which among other advantages, has overcome the necessity for motion and so, the energy needed to produce it.

In order to attain the production of large industrial electrical currents, using the principle that electrical current can be provided by just changing the flow of magnetic flux through an induction circuit, the above disclosure should be sufficient, however, as this operating principle needs to be embodied in a practical machine, there is a need to describe it in order to fully disclose how to carry out a practical application of this principle.

This principle is not new since it is just a consequence of the laws of induction stated by Faraday in the year 1831: what it is new and claimed in this patent, is the application of this principle to a machine which produces large industrial electrical currents and which, up to now, has only been obtained by transforming mechanical work into electricity.

We will therefore, provide a description of a machine based on the above principle disclosed in this patent; but it must be understood, and what is sought is the patent for the application of this principle, that all machines built based on this principle, will be included in the scope of this patent, whatever the form and way that has been used to make the application.

DESCRIPTION OF GENERATOR OF VARIABLE EXCITATION "FIGUERA"

The machine is comprised of a fixed inductor circuit, consisting of several electromagnets with soft iron cores enhancing induction in the induction circuit, which is also fixed in position and motionless, and which is composed of several coils, accurately positioned. As neither of the two circuits spin, there is no need to make them round, nor leave any space between one and the other.

Here what it is constantly changing is the intensity of the excitatory current which drives the electromagnets and this is accomplished using a resistance, through which circulates a operating current, which is taken from one power source and passed through one or more electromagnets, thus magnetising one or more electromagnets. When the current is higher, the magnetisation of the electromagnets is increased, and when it is lower, the magnetisation is decreased. Thus, varying the intensity of the current, varies the magnetic field which crosses through the induction circuit.

To assist in understanding this idea, it is convenient to refer to the attached drawing which is no more than a sketch intended to assist in understanding the operation of the machine built to implement the principle outlined above.

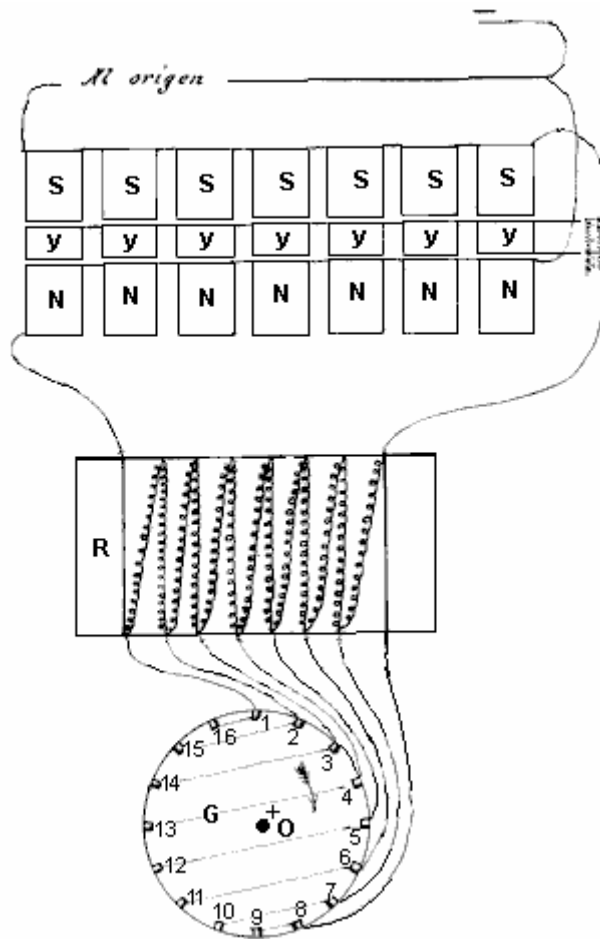

Suppose that electromagnets are represented by rectangles marked 'N' and 'S'. Located between their poles is an induction circuit represented by the line of small rectangles marked 'y'. A resistor 'R', drawn here in a simple form to help understanding of the entire system. Shown as '+' and '-', is the excitation power, drawn from an external source. As can be seen in the drawing, the different sections of this resistor connect with the commutator bars embedded in a stationary cylinder of insulating material. A sliding-contact brush 'O', which always connects with more than one contact, rotates, carrying the excitation current. One of the ends of the resistor is connected to the electromagnets N, and the other end of the resistor is connected to the electromagnets S. Half of the terminals of the resistor go to half of the commutator bars of the cylinder. The other half of these commutator bars are connected directly to the first set of commutator bars.

The operation of the machine is as follows: the brush O rotates inside cylinder G and is always in contact with two of the commutator bars. When the brush is touching contact 1 the current, flowing from the external source passes through the brush and powers electromagnets N to their maximum level of magnetisation, but the current passing through electromagnets S is insufficient to magnetise them because the whole of resistance R is too great to allow sufficient current to magnetise them. Therefore, the N electromagnets are fully powered while the S

electromagnets are not sufficiently powered to be magnetised.

When the brush connects with contact **2**, the whole of the current will not flow through electromagnets **N** because it has to pass through part of the resistor. Consequently, some current will pass through the electromagnets **S** because it has to overcome less resistance than in the previous case. This same reasoning applies to the case when brush **O** connects with each of the different contacts around the first semicircle. Then the brush **O** starts to connect with the commutator contacts in the other half, each of which are directly connected to their corresponding commutator contacts in the first half. In short, the resistor has the function of a current-splitter, powering either one set of electromagnets or the other set of electromagnets repeatedly. It can be seen that electromagnet sets **N** and **S** operate in a complementary manner, because while the first set is being progressively powered up, the other set is being progressively powered down. This sequence is repeated continuously causing an orderly a constant variation of the magnetic fields passing through the induction circuit. This action can be maintained by just the simple rotation of a brush or group of brushes which rotate in a circle inside cylinder **G** driven by a small electric motor.

As indicated by the drawing the current, once it has flowed through the electromagnets, returns to the power source where it originated. A small part of the output current from this device can be used to provide the 'external' excitation power mentioned above, thus making the machine self-exciting and to provide the current to operate the small motor which moves the brush causing the switching. Once started with an external power source, that external power source can be removed and the machine will continue to work indefinitely without any external power source.

This invention is really new, very daring, and above all, has huge technical and industrial consequences in all areas. This patent was not applied for until a working machine based on these principles had been built, thus proving the concept to be sound and practical.

ADVANTAGES OF THE ELECTRICAL GENERATOR "FIGUERA"

1. The completely free production of DC or AC electric current of any voltage which can be used for:
 - a. Providing a driving force.
 - b. Production of light.
 - c. Production of heat.
 - d. All other existing uses of electricity.
2. There is no need whatsoever for a driving force of any kind or chemical reactions or fuel consumption.
3. Needs little or no lubrication.
4. Is so simple that it can be easily operated by anyone.
5. Does not produce smoke, noise, or vibration when operating.
6. Indefinite operational life.
7. Has a wide range of uses: home management and industrial.
8. Easy construction.
9. Cheap to produce and market

NOTE

A 20-year patent is requested for a "NEW GENERATOR OF ELECTRICITY, so-called "FIGUERA" of variable excitation, designed to produce electrical currents for industrial applications without using either driving force, nor chemical reactions. The machine is essentially characterised by two series of electromagnets which form the inductor circuit, between whose poles induction coils are placed. Both the induction and inductor circuits remain motionless and yet are able to produce a current induced by the constant variation of the intensity of the magnetic field forcing the excitatory current (coming at first from any external source) to pass through a rotating brush which, in its rotation movement, connects with the commutator bars or contacts of a ring distributor or cylinder whose contacts are connected to a resistor whose value varies from a maximum to a minimum and vice versa, according with the commutator bars of the cylinder which operates, and for that reason the resistance is connected to the electromagnets **N** by one of its side, and the electromagnets **S** at the other side, in such a way that the excitatory current will be magnetising successively with more or less strength, the first electromagnets, while, simultaneously decreasing or increasing the magnetisation in the second set, determining these variations

in intensity of the magnetic field, the production of the current in the induced, current that we can use for any work for the most part, and of which only one small fraction is derived for the actuation of a small electrical motor which rotates the brush, and another fraction goes to the continuous excitation of the electromagnets, and, therefore, converting the machine to become self-exciting, being able to remove the external power which was used initially to excite the electromagnets. Once the machinery is in motion, no new force is required and the machine will continue in operation indefinitely.

All in accordance with the described and detailed in this report and as represented in the drawings which are attached.

Barcelona, the 30th of October, 1908. Signed: Constantino de Buforn.

There are some practical points which have not been included so far and which need to be mentioned. The Figuera patent shows the electromagnets as just rectangles, and while C-shaped electromagnet cores have been indicated and discussed, there is a distinct possibility that the electromagnet cores are just I-shaped or even a short cylinder which is several times wide than it is tall. These more simple shapes could make it very much easier to construct, although the C-shaped core need only be three straight sections placed together.

While it is definitely possible to construct each of the cores of the electromagnets from a solid block of iron, doing that will certainly allow eddy currents to generate heat in the cores, wasting useful energy in the process. It would be advisable therefore, to use the standard manufacturing method of assembling each core from a number of thin iron pieces, each separated from it's neighbour by a thin layer of insulating material. These components are available from companies which manufacture transformers.

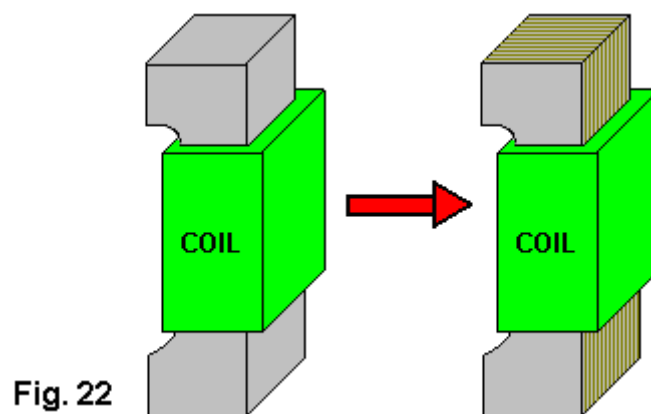

Fig. 22

I have to agree wholeheartedly with the anonymous contributor when he recommends that any attempted replications stay as close to the arrangement shown in the patent drawing, and have seven separate sets of three electromagnets. However, for subsequent experiments, a somewhat easier construction with just one set of electromagnets might be tried, making the electromagnets equal in length to the seven separate units:

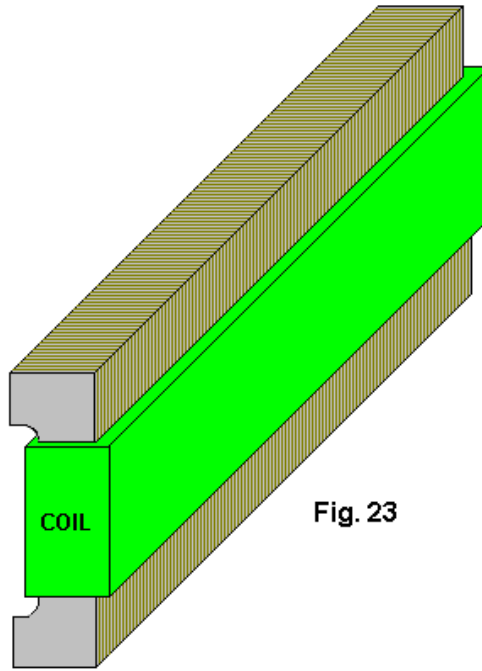

Fig. 23

This arrangement has advantages if the design is taken on into manufacturing as less construction is needed.

Figure 15 shows two electromagnets connected at the top to the battery Minus and at the bottom to the battery Plus. But, one is marked with a North pole at the top and the other with a South pole at the top, so perhaps some explanation would be helpful. If the coils are connected that way, then one will have to be wound in a clockwise ("CW") direction and the other in a counter-clockwise ("CCW") direction:

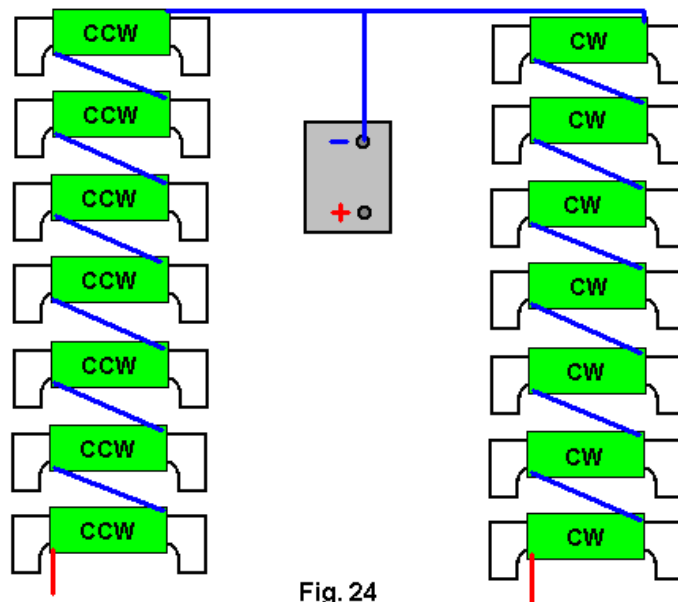

Fig. 24

Or the alternative is to have all of the electromagnets wound in the same way, and adjust the connections:

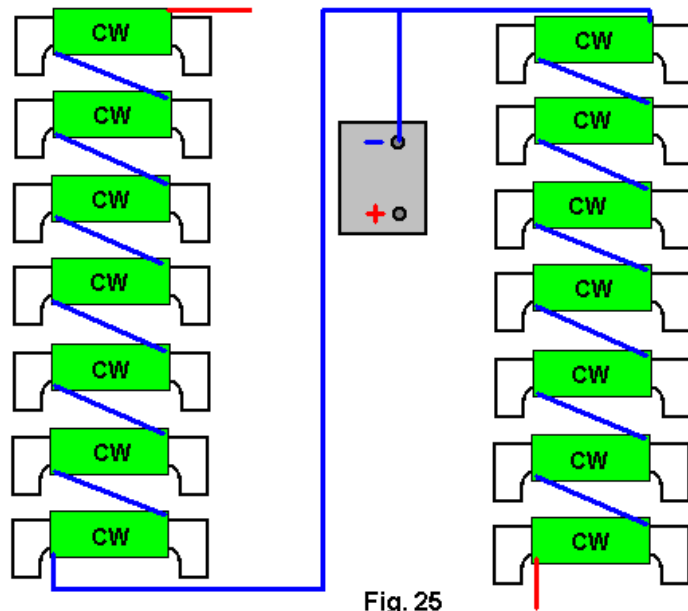

Fig. 25

The Figuera design was implemented more than a hundred years ago, and so Clemente did not have any semiconductors available to him, and so he used a motor-driven commutator arrangement to produce the electrical switching which he needed.

While I am in no way opposed to mechanical switching, especially where prototypes are concerned, there has to be an advantage in using solid-state switching, and while I am by no means an expert in that field, the following suggestions might be useful for experienced circuit builders.

In spite of the wire-wound resistor bank having only eight connection points, the switching has to have sixteen outputs due to the backwards and forwards switching sequence which is used. A solid-state 16-way switching module can be constructed from two CD4017 Divide-by-Ten integrated circuits like this:

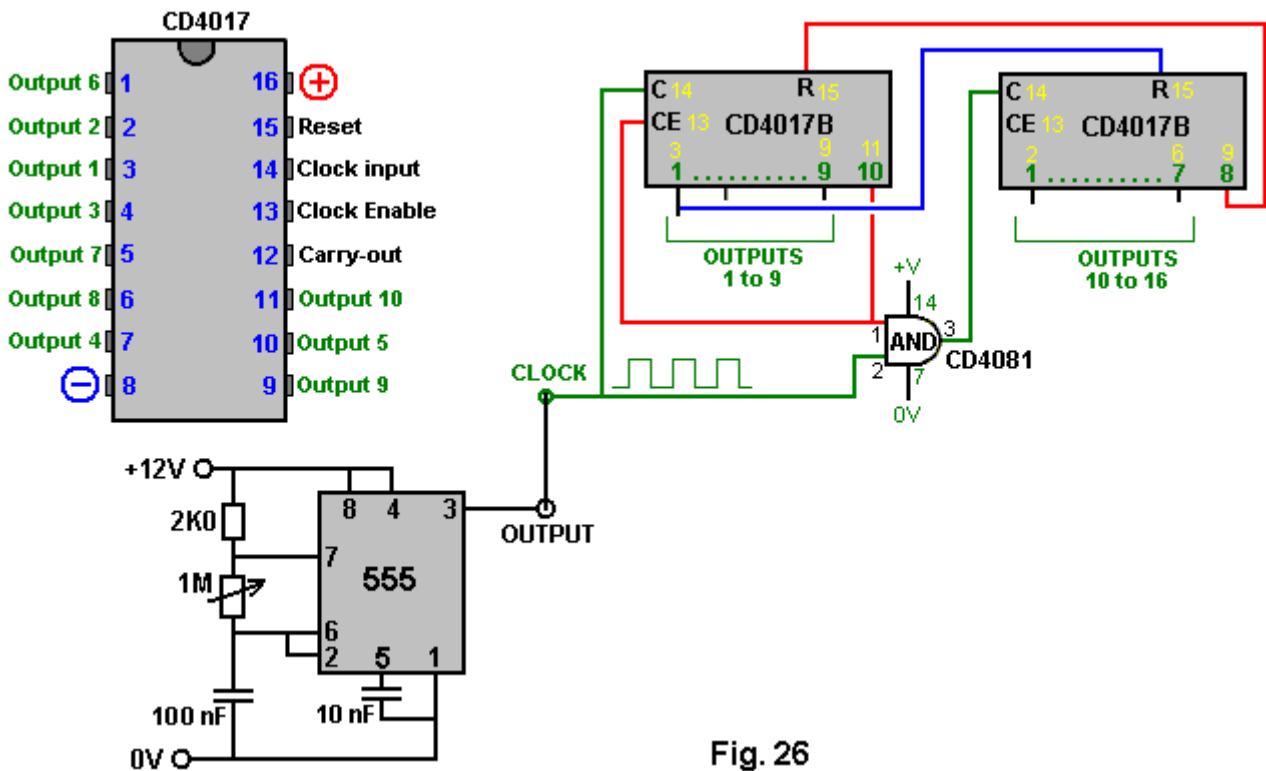

Fig. 26

This arrangement gives sixteen outputs in sequence, so two outputs need to be connected together in order to match the mechanical switching which Clemente used. Presumably, it would not be advisable to connect two outputs directly together, and so an isolation diode (say, a 1N4148 type) would be required on each output.

Please note that the pin connections shown here have been revised as it appears that in this circuit, the output pin 3 of the second 4017 chip does not function as expected:

Output Number	Chip and Pin Nos	Paired with Output	Resistor Connection Point
1	Chip 1 Pin 3	16 (Chip 2 pin 6)	1
2	Chip 1 Pin 2	15 (Chip 2 pin5)	2
3	Chip 1 Pin 4	14 (Chip 2 pin1)	3
4	Chip 1 Pin 7	13 (Chip 2 pin 10)	4
5	Chip 1 Pin 10	12 (Chip 2 pin7)	5
6	Chip 1 Pin 1	11 (Chip 2 pin 4)	6
7	Chip 1 Pin 5	10 (Chip 2 pin 2)	7
8	Chip 1 Pin 6	9 (Chip 1 pin 9)	8
9	Chip 1 Pin 9		
10	Chip 2 Pin 2		
11	Chip 2 Pin 4		
12	Chip 2 Pin 7		
13	Chip 2 Pin 10		
14	Chip 2 Pin 1		
15	Chip 2 Pin 5		
16	Chip 2 Pin 6		

Eight power transistors can be used to energise each resistor connection point in the sequence required. As mechanical switching was used by Clemente, it really did not matter which way round the battery connections were made. We can match his switching exactly by using PNP power transistors (or possibly, P-channel FETs) which would make the arrangement like this (with just two of the eight connections being shown):

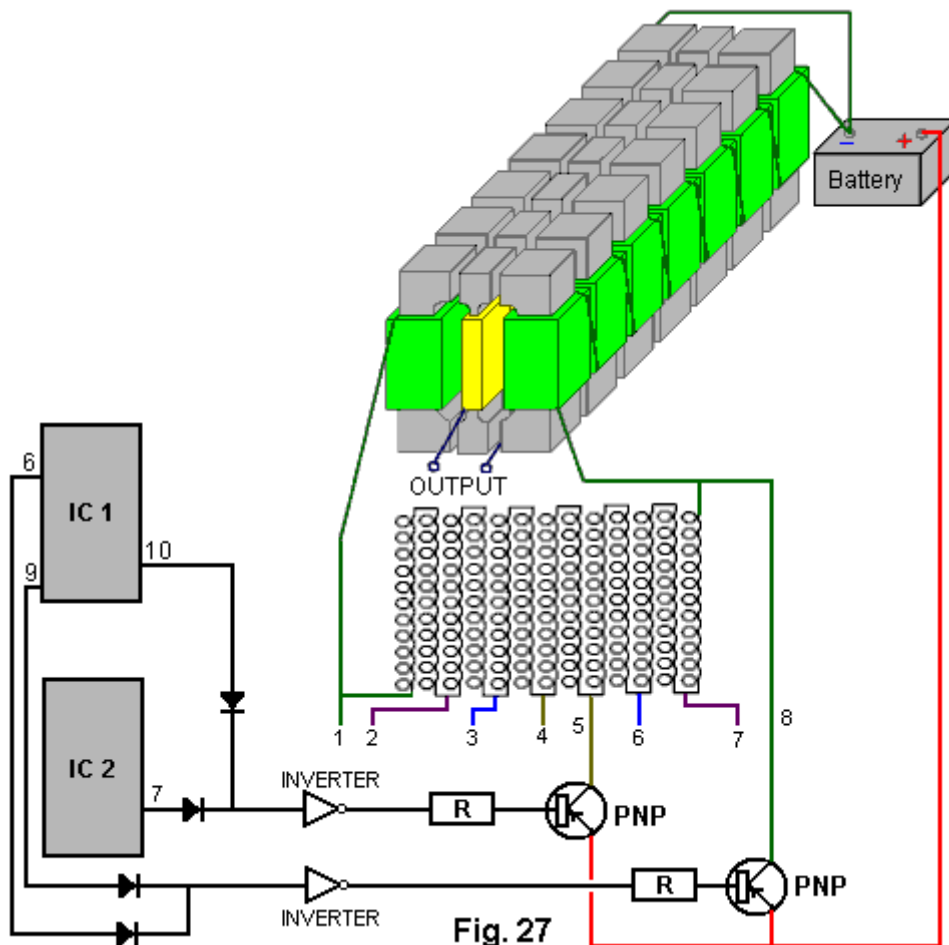
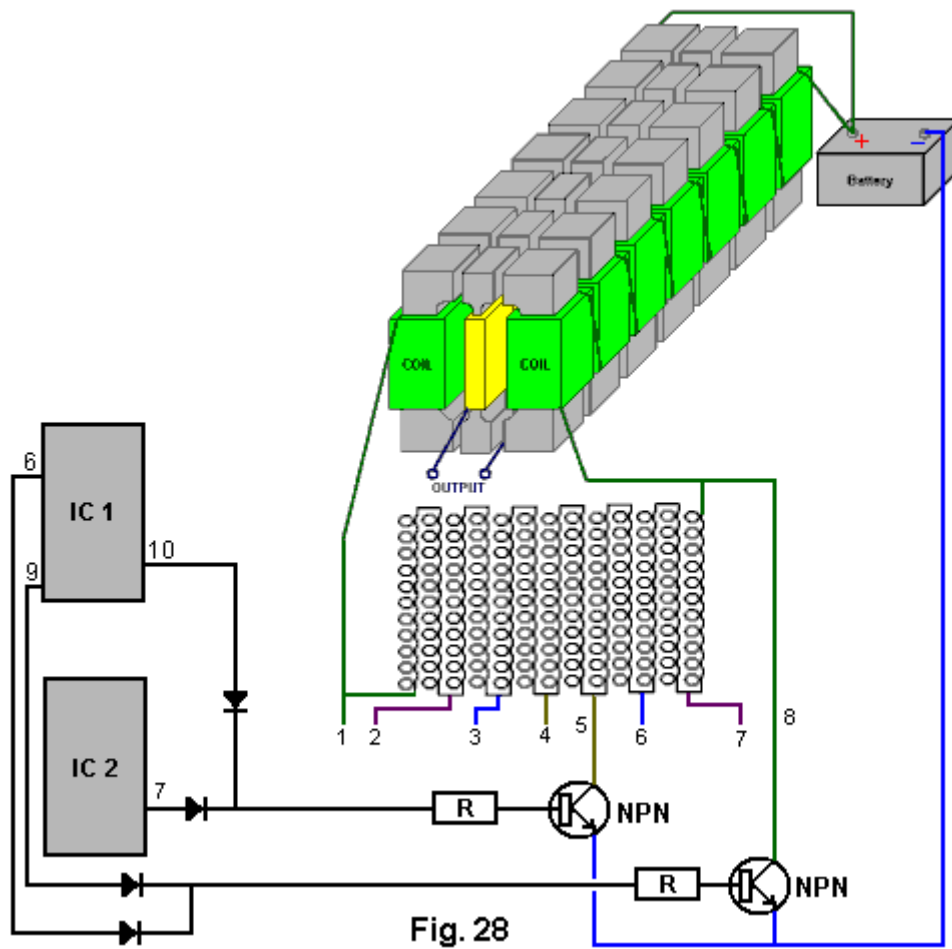

Fig. 27

Or you can reverse the battery for the easier NPN option:



I have been asked by an electronics novice to show a possible construction form for this sort of circuit. I am not particularly good at that sort of thing, but here are a couple of diagrams of a non-optimised layout for a standard size of common stripboard:

T = 2N2222 Transistor D = 1N4001 Diode R = 4.7K Resistor

→ C = Connection to 2N3055 Collector → B = Connection to 2N3055 Base

• = Break in the copper strip on the underside of the board

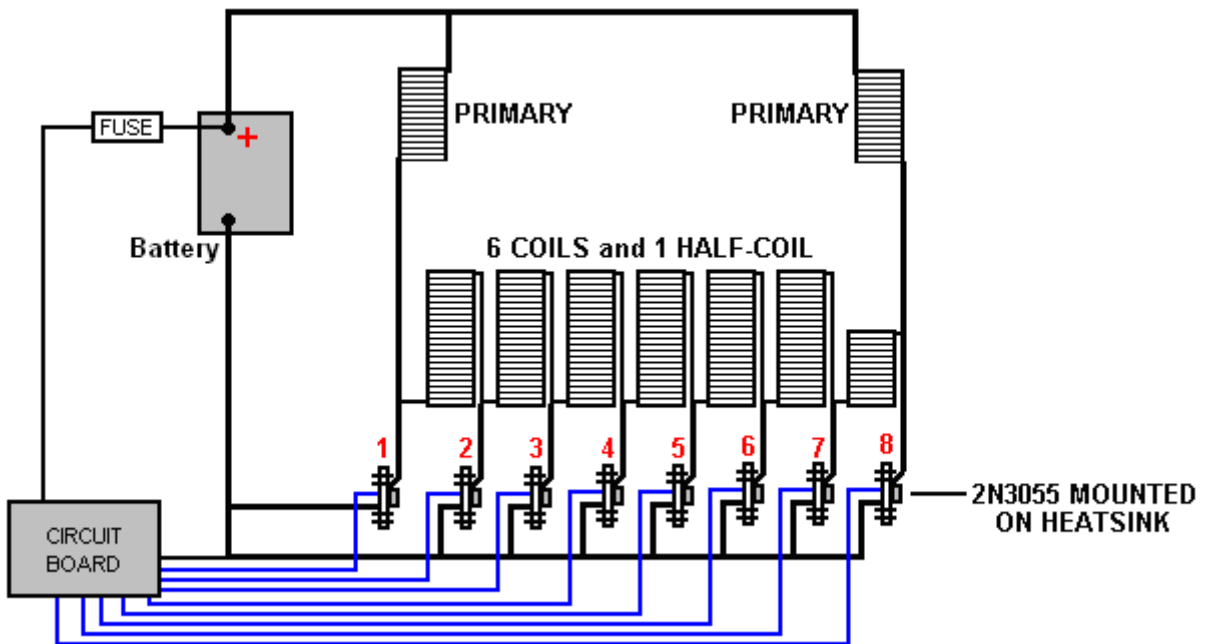
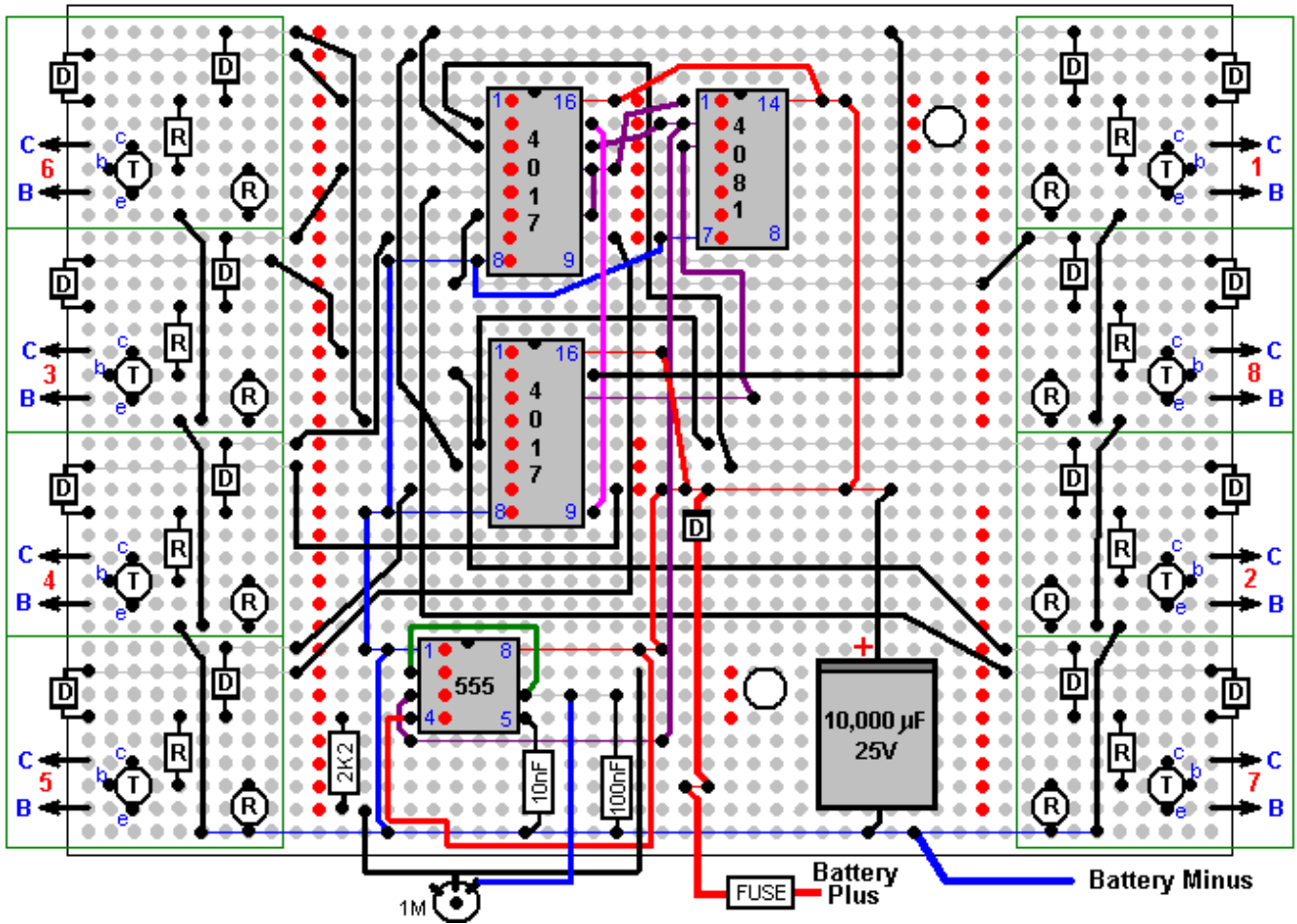

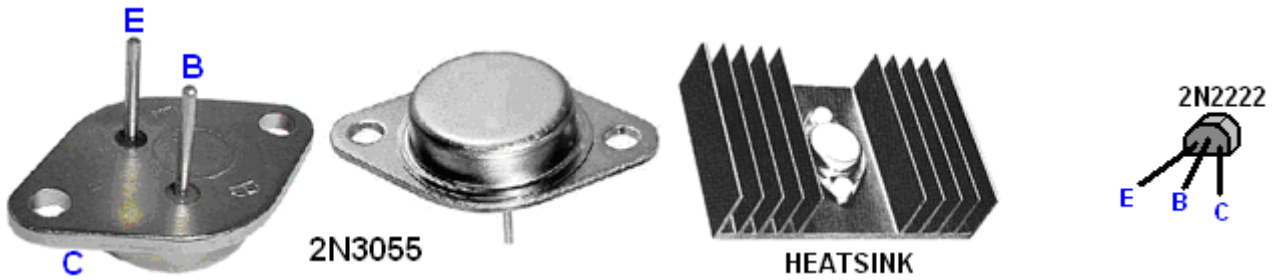

Experienced experimenter 'Woopy' has posted a video of a quick experiment to test the working principle of this Figuera design. It is at <http://www.youtube.com/watch?v=HIOGEnKpO-w&feature=g-u-u> and in it, he short-circuits the secondary winding, showing that the input power is totally unaffected by the current draw from the secondary.

He shows some very interesting oscilloscope shots:

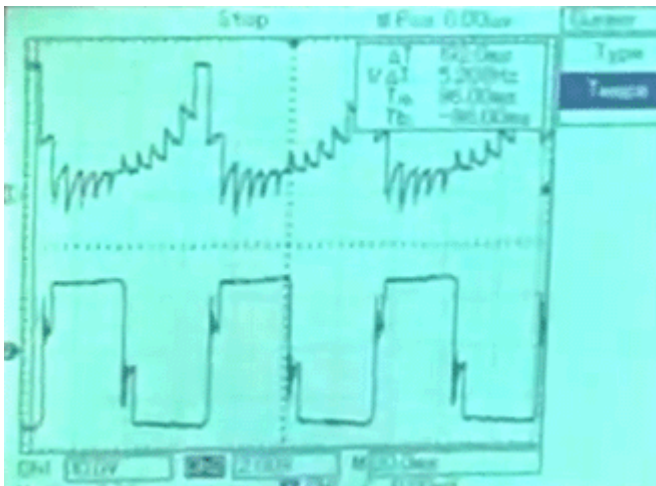

One primary and the secondary output

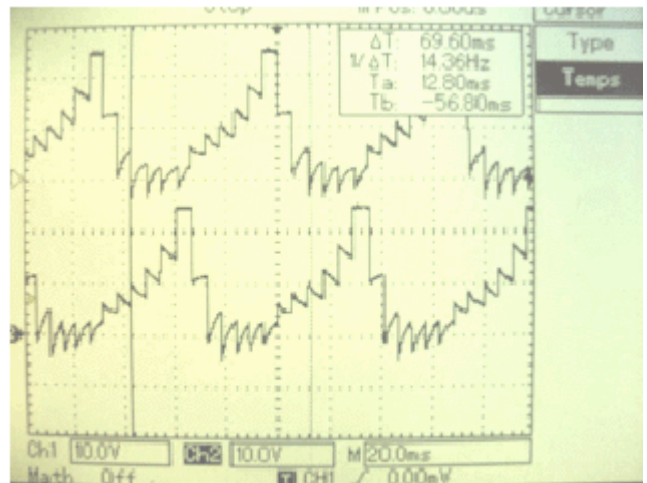

Both primaries, showing their phases

The first screen shot surprises me as it shows clearly that the output is actually an excellent square wave while I would have expected it to be a sine wave as it is coming from a coil which has inductance. The second shot shows very clearly, how the two banks of primary electromagnets operate out of phase with each other thanks to Woopy's mechanical 6-way switching arrangement. It is reported that Mr Figuera ran a 20-horsepower motor with his prototype and if that motor were fully loaded, then that is 15 kilowatts of power, easily enough to power a household.

Please bear in mind that if the electromagnets are made from iron, whether laminated or not, that iron restricts the frequency, probably to 500 Hz or less, and so it is necessary to keep the frequency that low if using a solid-state circuit to drive the transformer. For 60 Hz output with mechanical switching, requires the motor to run at 3,600 rpm which is fairly fast although definitely achievable. Also, the output power will be limited by the current handling capacity of the wire in the secondary winding. The first page of the Appendix shows the current capacities for the standard AWG and swg wire sizes.

Because this Figuera design is so important, being low-voltage, high power and not needing tuning I have recently been asked to explain it in greater detail and suggest some component values for people starting to experiment with it. I am not an electronics expert, and so my suggestions need to be taken as just that, namely, suggestions for a possible starting point for experimentation.

The first point is that the two halves of the primary winding of the transformer become electromagnets when current flows through their windings. The strength of an electromagnet increases as the current flow increases. Large current: strong magnet. Small current: weak magnet.

Clemente Figuera's circuit is arranged so that the current through the windings is made to vary so that when one magnet is strong, the other one is weak. It works like this:

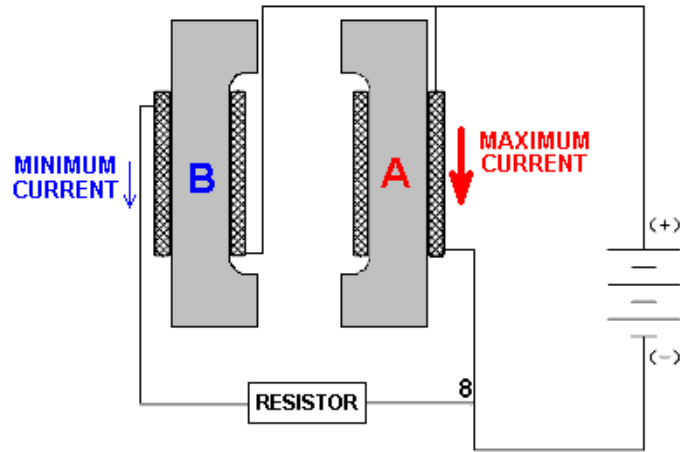

When the mechanical (or transistor) switching connects the battery to point '8' in the previous diagrams, we get the situation shown above. Current from the battery flows directly through the right-hand electromagnet "A", making it the strongest magnet that it can be at that battery voltage. The electromagnet "B" on the left gets current flow from the battery all right, but that current is reduced because it has to flow through the resistor.

When the switching changes and the battery is connected to point "1" in the previous diagrams, we get this arrangement:

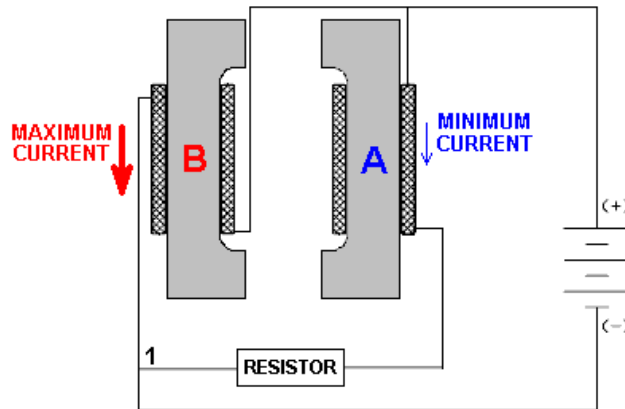

Here, electromagnet "B" is free of the resistor and gets its maximum possible current, making it the strongest magnet which it can be at that battery voltage, while electromagnet "A" has its current reduced by the resistor getting in the way, making it the weakest magnet it can be when the system is running.

If we switched between these two positions, we would get a square wave style of operation, but Clemente did not do that. Instead, he split the resistor into seven parts (if Fig.14 is drawn correctly, one part having only half the resistance of the other parts). This makes the arrangement like this:

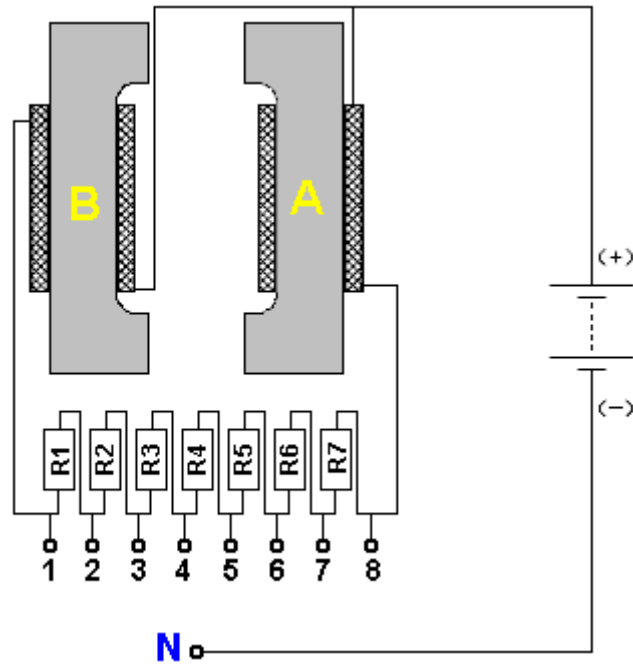

When the battery negative “N” is connected to point “2”, then the current flow through electromagnet “B” is hindered by resistor R1, but the current flow through electromagnet “A” is hindered by resistors R2 and R3 and R4 and R5 and R6 and R7, which together, have a far higher resistance than R1 on its own. This makes the current flow through electromagnet “B” far greater than the current flow through electromagnet “A”.

When the battery negative “N” is connected to point “3”, then the current flow through electromagnet “B” is hindered by resistor R1 and resistor R2, but the current flow through electromagnet “A” is hindered by resistors R3 and R4 and R5 and R6 and R7, which together, have a far higher resistance than resistors R1 and R2. This makes the current flow through electromagnet “B” still greater than the current flow through electromagnet “A”.

When the battery negative “N” is connected to point “4”, then the current flow through electromagnet “B” is hindered by resistors R1, R2 and R3, and the current flow through electromagnet “A” is hindered by resistors R4, R5, R6 and R7, which together, have a higher resistance than resistors R1, R2 and R3. This makes the current flow through electromagnet “B” somewhat greater than the current flow through electromagnet “A” (nearly a balanced flow as resistor R7 is only half the value of each of the other resistors).

When the battery negative “N” is connected to point “5”, then the current flow through electromagnet “B” is hindered by resistors R1, R2, R3 and R4, while the current flow through electromagnet “A” is hindered by resistors R5, R6 and R7, which together, now have a lower resistance than resistors R1, R2, R3 and R4. This makes the current flow through electromagnet “B” somewhat less than the current flow through electromagnet “A”.

When the battery negative “N” is connected to point “6”, then the current flow through electromagnet “B” is hindered by resistors R1, R2, R3, R4 and R5, while the current flow through electromagnet “A” is hindered by resistors R6 and R7, which together, now have a much lower resistance than resistors R1, R2, R3, R4 and R5. This makes the current flow through electromagnet “B” much less than the current flow through electromagnet “A”.

When the battery negative “N” is connected to point “7”, then the current flow through electromagnet “B” is hindered by resistors R1, R2, R3, R4, R5 and R6, while the current flow through electromagnet “A” is hindered by resistor R7, which has a very much lower resistance than resistors R1, R2, R3, R4, R5 and R6 together. This makes the current flow through electromagnet “B” very much less than the current flow through electromagnet “A”.

Clemente has arranged the battery switching sequence to be to points 1, 2, 3, 4, 5, 6, 7, 8, 8, 7, 6, 5, 4, 3, 2, 1, repeating over and over again. This makes the connections to points 1 and 8 to be twice as long compared to the connection times for the intermediate points, giving a sine-wave shape rather than a sawtooth shape.

There is current flow through both electromagnets at all times. The current flow is never broken although, as you can see, the intensity of the current flow varies all the time with each electromagnet getting stronger than the other one repeatedly.

The mechanical switching used by Clemente will work perfectly well, although there will be motor noise and wear on the switch contacts. A solid state version will be silent, more reliable and much longer lasting. There are many

different way to build most electronic circuits and each builder will have his own favourite way of constructing the circuit. This Figuera circuit does not specify the battery voltage and so some people will want to use a twelve volt battery. As many FET transistors need as much as ten volts in order to switch on properly, a twelve volt supply is probably a little low for them, and so I suggest using the older bipolar transistors.

As the transistor has to carry the current which passes through the electromagnets, it needs to be able to handle considerable current flow. The very common 2N3055 transistor can do that (as can many other suitable transistors). The switching rate is very, very slow for a transistor and so speed is not an issue. The voltage is very low, and so that is not an issue either and so the 2N3055 transistor is definitely a possible choice.

In common with most high-power transistors, the current gain is low being between 20 and 30 typically. That means that to switch it on properly, a current of one twentieth of the switched current has to be fed into the base of the transistor. That base current is too high to be convenient, so we can raise the transistor gain to around 6000 by adding in a low-power transistor such as the 2N2222 transistor. The two transistors are connected together in a configuration called a 'Darlington Pair' which looks like this:

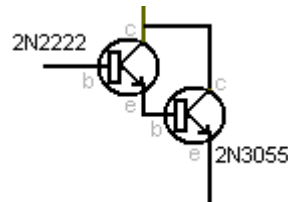

In this arrangement, the two Collectors are connected together, while the Emitter of the 2N2222 transistor feeds into the Base of the 2N3055 power transistor. With a high gain of six thousand or so for our transistor pair, we need to limit the current flowing through their combined Base-to-Emitter junction, and so we introduce a current limiting resistor R8 in the following circuit suggestion:

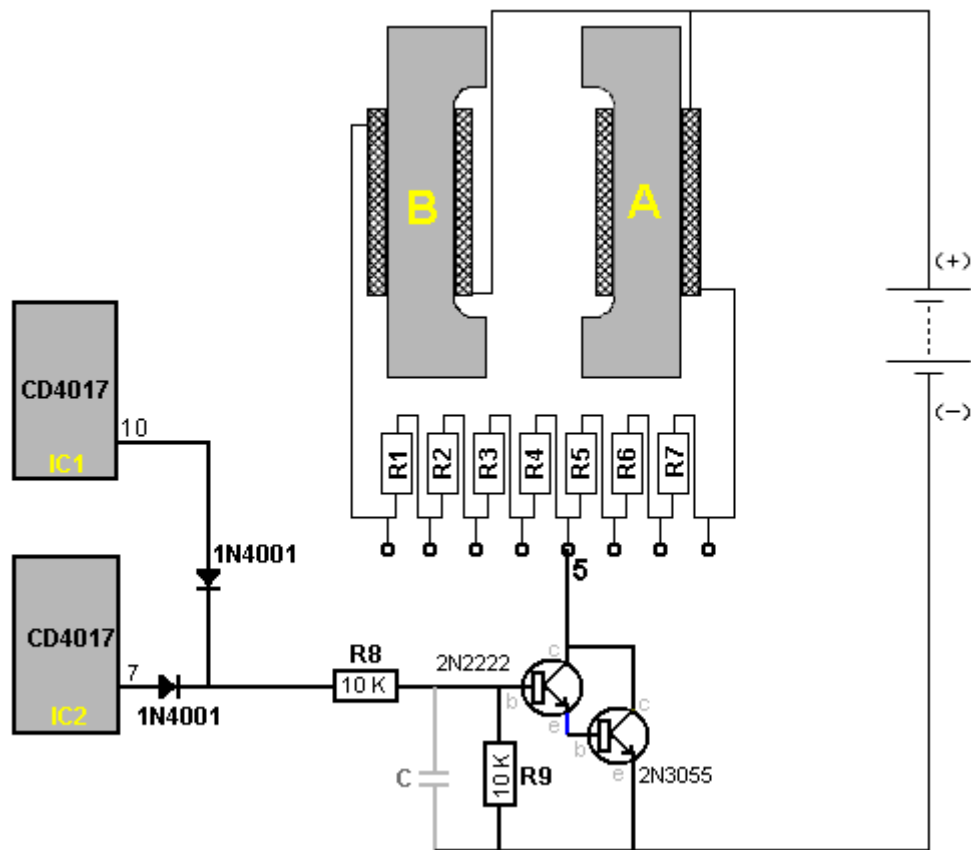

The 10K resistor value shown would limit the transistor current to about nine amps, while a 4.7K resistor would allow around eighteen amps. Each transistor pair is only on for one eighth of the time, but the 2N3055 transistors need to be mounted on a heat-sink. If a single metal plate is used as a heat-sink for all eight 2N3055 transistors, then mica washers (available from the supplier of the transistors) must be used between each transistor and the plate because the Collector of each 2N3055 transistor is its metal case and in this circuit, the Collectors do not connect to a common point. The mica washers pass heat but not electricity. Separate heat-sinks can, of course, be used.

The capacitor "C" in the above circuit diagram will probably not be needed. The switching needs to maintain a constant current flow through both electromagnets. I would expect the 4017 chip switching to be fast enough to allow this to happen. If that proves not to be the case, then a small capacitor (probably 100nF or less) can delay the switch-off of the transistors just long enough to allow the next transistor in the sequence to be switched on to provide the required 'Make-Before-Break' switching.

As indicated in the table above, the 4017 pins which feed the transistor pairs through the 1N4148 (or similar) diodes are:

- IC1 pin 3 and IC2 pin 6 for resistor connection point 1.
- IC1 pin 2 and IC2 pin 5 for resistor connection point 2.
- IC1 pin 4 and IC2 pin 1 for resistor connection point 3.
- IC1 pin 7 and IC2 pin 10 for resistor connection point 4.
- IC1 pin 10 and IC2 pin 7 for resistor connection point 5.
- IC1 pin 1 and IC2 pin 4 for resistor connection point 6.
- IC1 pin 5 and IC2 pin 2 for resistor connection point 7.
- IC1 pin 6 and IC1 pin 9 for resistor connection point 8.

This Figuera design is very attractive as it uses only simple, readily available materials, low voltage and does not require difficult tuning. It also has the potential to be self-powered if part of the output is used to provide a voltage-stabilised power supply for the input power and the remaining output power can be kilowatts if the wire diameters chosen can carry that much current.

Chapter 12 explains electronic circuitry in more detail.

A contributor who wishes to remain anonymous does not like the circuit arrangement shown above and prefers this circuit which he has built and tested:

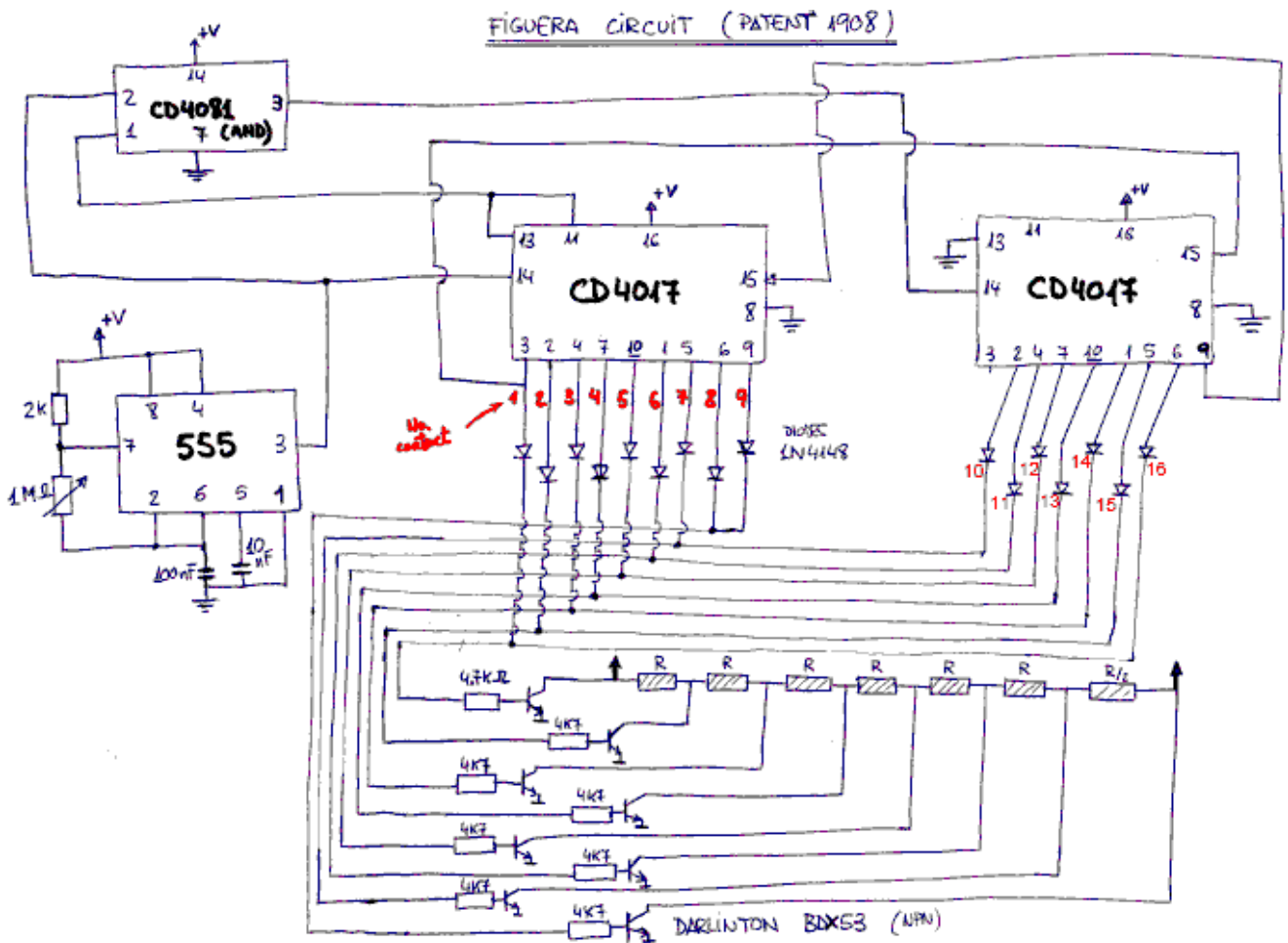

The NPN Darlington transistor BDX53 in this circuit is not available everywhere around the world and if that is the situation in your area, then using a 2N2222 transistor feeding a 2N3055 (or TIP3055) transistor as show originally will work just the same.



The Self-Powered Generators of Barbosa and Leal

In July 2013, two Brazilian men, Nilson Barbosa and Cleriston Leal, published a series of patents which appear to be very significant. Their patent WO 2013/104042 published on 18th July 2013, is entitled “Electromagnetic device for Capturing Electrons from the Ground to Generate Electricity” and has some very interesting features. It describes a simple device which they describe as an “electron trap”. Their patents are written in Portuguese and an attempted translation of three of them is included at the end of the Appendix.

An unusual feature of this design is the fact that it has a continuous conductive loop, in which it is claimed, current flows continuously, even without the need for an applied voltage. Instead, it is the magnetic fields of electromagnets which keep the current flowing. They state that an insignificant amount of input power produces a substantial power output, and they consider a COP of 100 to be about the minimum performance which can be expected from the design. That is a 1 watt input for a 100 watt output. One version of the electron trap looks like this:

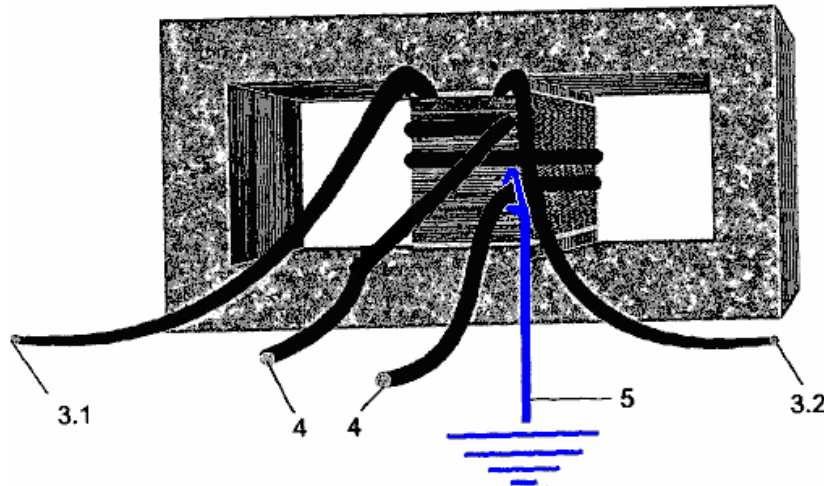

The inventors describe their device like this: “this electromagnetic-field-generating device, powered by a power source, produces an electromagnetic field which induces an electric current in a closed conductive circuit, creating an interaction between the magnetic poles of the equipment and the magnetic poles of the earth - through both electromagnetic attraction and repulsion. An endless supply of electrons is drawn from the earth into the conductive closed loop, which is connected to the ground through a conductive interconnected grid. The attracted electrons add to the current already flowing in the conductive closed loop, making power available for driving high-power loads, although the device itself is supplied with only a small amount of power.”

One very interesting feature is that the continuous-loop coil formed by wire **4** in the diagram above, is literally, only two turns of wire. The power-gaining mechanism, amazingly, is the earth wire (shown in blue) which is merely wrapped around wire **4** and not directly connected to it as the electron-transfer link is by induction. With this arrangement, the current circulating in the closed loop wire **4**, attracts more electrons from the ground, flowing through the wrapped connection of wire **5**, into wire **4**, augmenting the current flow there by a major amount. Wire **3** can have an alternating voltage applied to it in order to get alternating current in wire **4**, but please understand that the current flowing in wire **4** is **not** the result of the current in wire **3**. If the current in wire **3** is DC, then the current in wire **4** will be DC as this is **not** a conventional transformer, but instead, it is an electron trap, operating in an entirely different way.

The electron trap can be connected in an AC circuit of this type:

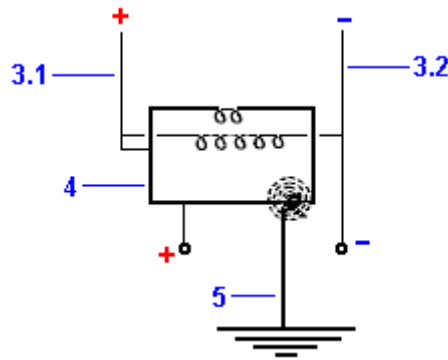

Here, the earth wire **5** is wrapped around the continuous loop wire **4**, feeding it additional electrons captured from the ground. The ends of wire **4** are connected together to form the loop, and that connection also forms the positive side of the output (where a DC output is being produced). The magnetic field produced by the current flowing in wire **3**, acts on the electron flow coming from the earth, but as it does not provide any of the electric power flowing in wire loop **4**, the current flowing in wire **3** can be tiny, without affecting the power output.

In their patent WO 2013/104043, also of 18th July 2013, they show several different ways of connecting their electron trap in a useful circuit. For example, like this:

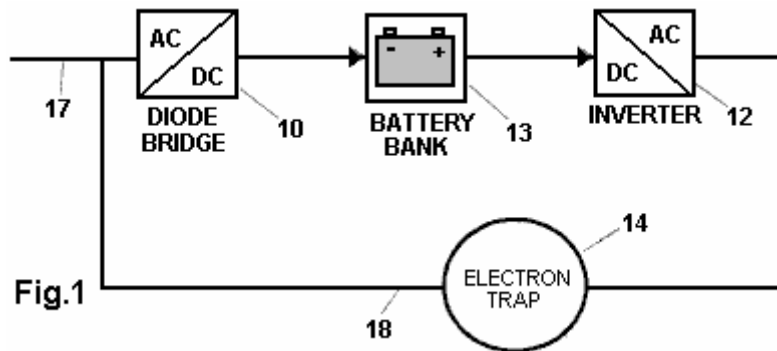

Here, the battery **13**, is used to power an ordinary inverter **12**, which produces a high alternating voltage, in this case, at very low power. That voltage is applied to the wire 3.1 to 3.2 of the electron trap, creating an oscillating magnetic field, which creates an oscillating inflow of electrons into the closed loop wire (**4**), which creates an amplified electrical output at the same frequency – typically 50 Hz or 60 Hz as those are the common mains frequencies. That amplified power output from the electron trap **14**, is passed along wire **18** to an ordinary diode bridge **10**, and the pulsing DC from the bridge is smoothed and used to replace the battery input to inverter **12**. The battery is now switched out of the circuit and, as well as making the overall circuit self-powered, the power coming from the electron trap is used to recharge the battery if it needs recharging (and/or, perhaps, to charge the batteries of an electric car). Because the electron trap needs almost no input power at all, the input power to the inverter is very small, and so a good deal of additional AC power can be drawn off through cable **17**, and used to drive powerful electrical loads, with no electrical power being needed from the battery. Being self-powered, the COP value for the circuit is infinity.

Just as there are several different ways of using an electron trap in a circuit, there are several ways of constructing and connecting an electron trap. While it is possible to arrange the components so that the power output is 2-phase or 3-phase, here we will just deal with the ordinary, household, single-phase power supply.

The first variation is to use more than one frame. Two frames can be connected like this:

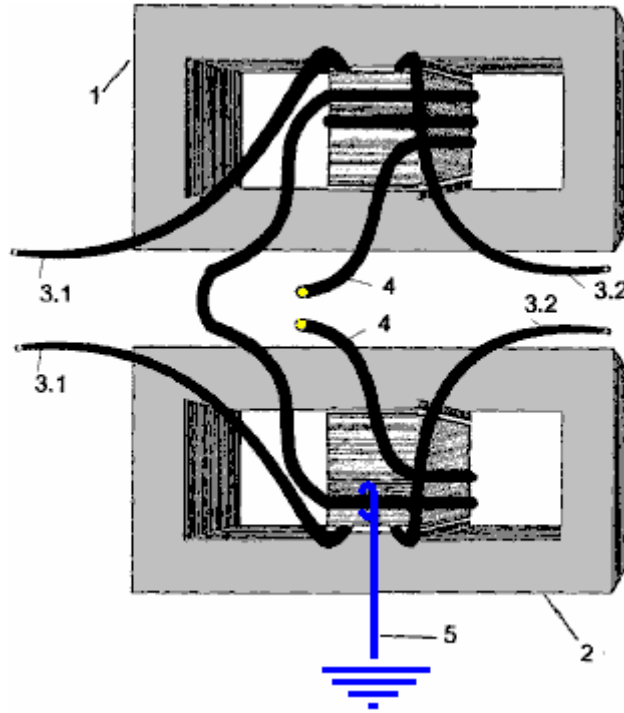

This is the actual drawing from the patent and it presents a slight problem in that it is not physically possible to implement the number 4 wire in the way shown. Each frame will have two complete turns wound on it, although the drawing does not show this. Because of the inaccuracy of the drawing, I am not able to say if the coil turns on frame 2, are in the same direction as those on frame 1. There are four possible ways of winding these 2-turn coils when interconnecting them, so perhaps experimentation can be used to determine which method works best.

With this two-frame arrangement, there is just the one earth wire 5, as before, again, it is wrapped around wire 4 rather than being physically connected to it. The continuous wire loop 4 has two ends as before, but there are now two 3.1 wire ends and two 3.2 wire ends. The Portuguese translation programs produce highly questionable results for this area of the patent, but I gather that the inventors intend the two 3.1 ends to be connected together and the two 3.2 ends to be connected together, and then the joined ends are treated exactly as before, effectively putting the two windings in parallel.

One disadvantage of this design is that it is not portable due to the earth connection. Barbosa and Leal deal with this problem in their patent WO 2013/104041 of the same date where they show a method of constructing an electron trap which collects excess electrons from the air. If you feel that there are no excess electrons in the air, then consider the fact that all of the aerial designs in chapter seven all extract and use those electrons. Also, consider the amount of electricity in a lightning strike, where much of the electrical energy comes from the air, and remember that world wide, there are between 100 and 200 lightning strikes every second.

The free-electrons-in-the-air electron trap is somewhat more complicated than the earth-wire electron trap, with four pairs of coils (3 and 4) being mounted inside two aluminium hemispheres (1):

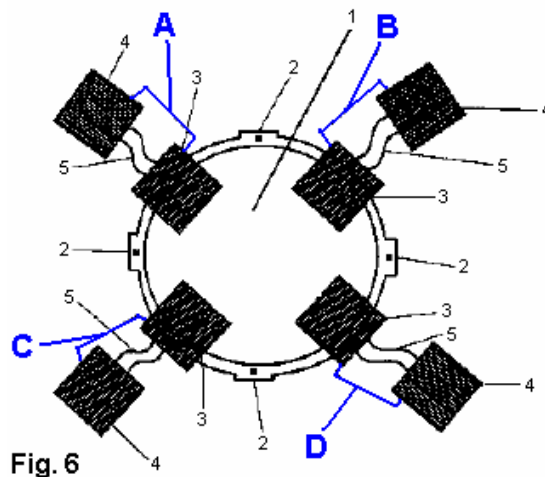

The methods for using the air-electrons trap are the same as those for the earth-wire electron trap.

An earth-wire video demonstration is here: <http://www.youtube.com/watch?v=iRSP7h73u-Q> with 22 watts producing 6 kilowatts.



An attempted translation of the three Barbosa/Leal patents is here:

WO Patent 2013/104043

18th July 2013

Inventors: Nilson Barbosa and Cleriston Leal

ELECTRIC ENERGY GENERATION SYSTEM WITH FEEDBACK

Note: These three patents are in Portuguese and what is shown here is a low-quality attempt at translation into English using a translation program. The originals can be downloaded free from: http://worldwide.espacenet.com/singleLineSearch?locale=en_EP.

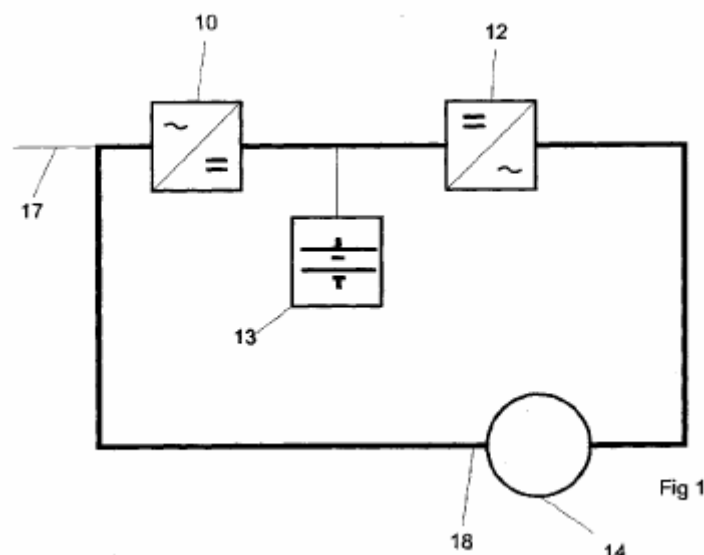

Abstract:

The present invention relates to electric energy generation equipment comprising a basic circuit formed by a rectifier (10), for example, an AC/DC converter connected in series to an inverter (12), for example, a DC/AC converter, and a bank of batteries (13) connected in series between the rectifier (10) and the inverter (12). An electron-capturing element (14), which can be either a free space electron-capturing element or, alternatively, an earth electron-capturing element, is connected in series to the basic circuit formed by the rectifier (10), the inverter (12) and the battery assembly (13). The bank of batteries (13) powers the basic circuit because it is connected to the system. Consequently, the inverter (12) converts direct current into alternating current and supplies this

current to the electron-capturing element (14). After receiving the electric current from the inverter (12), the electron-capturing element (14) starts capturing electrons from the alternating current and powering the rectifier (10), which converts the alternating current into a direct current in order to recharge the bank of batteries (13) and power the inverter (12) which powers the electron-capturing element, closing the feedback loop, and also providing electric energy for consumption by external loads.

WIPO Patent Application WO/2013/104043 Filing Date: 01/11/2013
Application Number: BR2013/000016 Publication Date: 07/18/2013

Assignee: EVOLUÇÕES ENERGIA LTDA (Rua Santa Tereza 1427-B Centro - Imperatriz -MA, CEP -470 - Maranhão, 65900, BR)

SELF-POWERED ELECTRICITY GENERATOR.

Technical field

The present invention relates to a device for generating electricity, in particular self-powered equipment for generating electricity.

Description of the Related Art

There are many methods for generating electricity using electromagnetism, but all of these are electromechanical devices using magnets and have limited generating capacity and an ecological impact which makes them unsuited to large scale projects.

Objectives of the Invention

The aim of this invention is the sustainable generation of electricity, using a generator which is able to produce large amounts of electricity from an extremely low input current, which initially is supplied by a bank of batteries, but subsequently is supplied by the output from the generator which is also able to power external loads.

The above objective, and other objectives, are achieved by the present invention through the use of a typical Uninterruptible Power Supply circuit comprising of an AC/DC rectifier feeding a battery bank which powers a DC/AC inverter, which is connected to a device to trap electrons from space (as described in Brazilian patent application No. BR1020120008378 of 13th January 2012) or alternatively, a device which extracts electrons from the Earth (as described in Brazilian patent application No. BR1020120008386 of 13th January 2012), which then passes the extracted electrons to the AC/DC rectifier, charging the battery bank, thus closing the loop as well as providing electricity to power external loads.

The self-powered system for generating electricity from the present invention can be fixed or mobile. It is fixed when using electron capture from the earth due to the ground connection, or mobile when using electron capture from space.

The self-powered electricity generating system of this invention may be configured in several different ways, each using the same inventive concept but using different arrangements of components. Different versions include single-phase, two-phase or three-phase versions, producing outputs of any power and voltage.

Brief Description of the Drawings

The present invention will now be described with the aid of drawings, but this patent is not limited to the versions and details shown in these drawings, although they show additional details and advantages of the present invention.

The drawings:

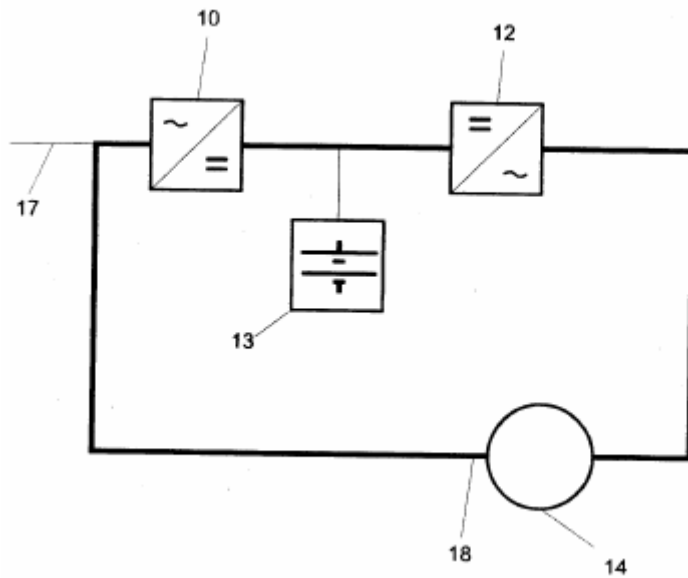

Figure 1 - shows a basic circuit system for self-powered electricity generation of the present invention

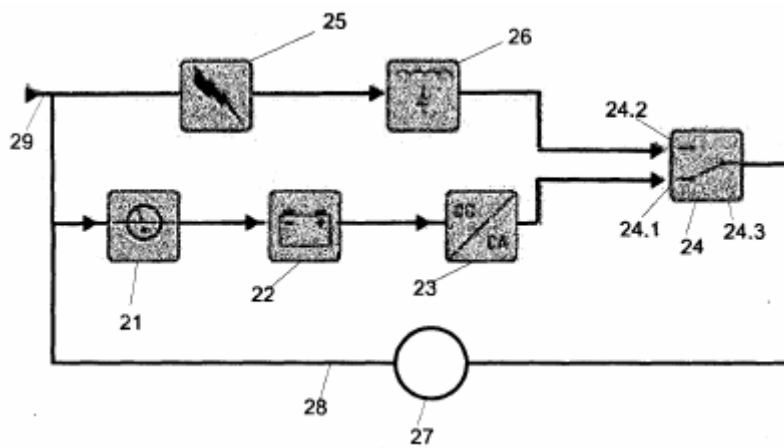

Figure 2 - shows a first embodiment of the constructive system for self-powered electricity generation of the present invention;

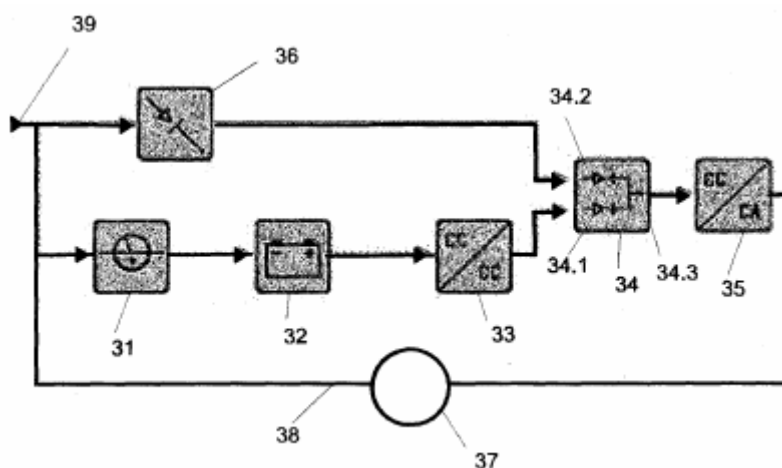

Figure 3 - shows a second embodiment of the self-powered system for generating electricity of the present invention;

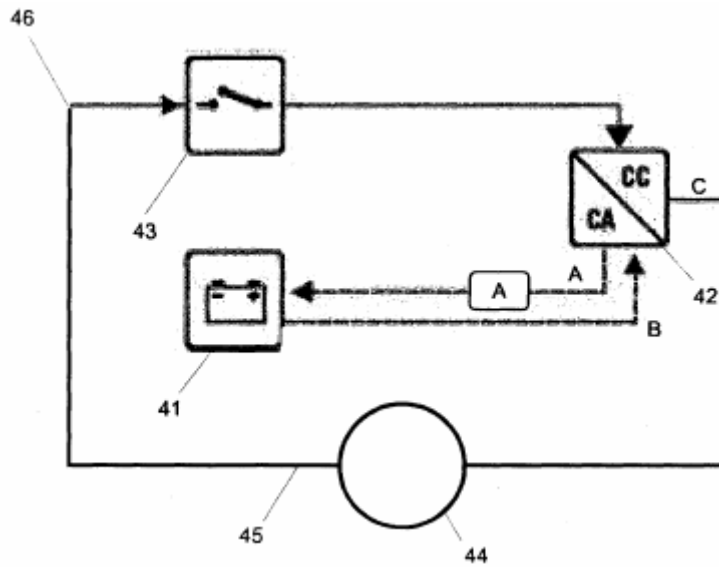

Figure 4 - shows a third embodiment of the self-powered system for generating electricity of the present invention;

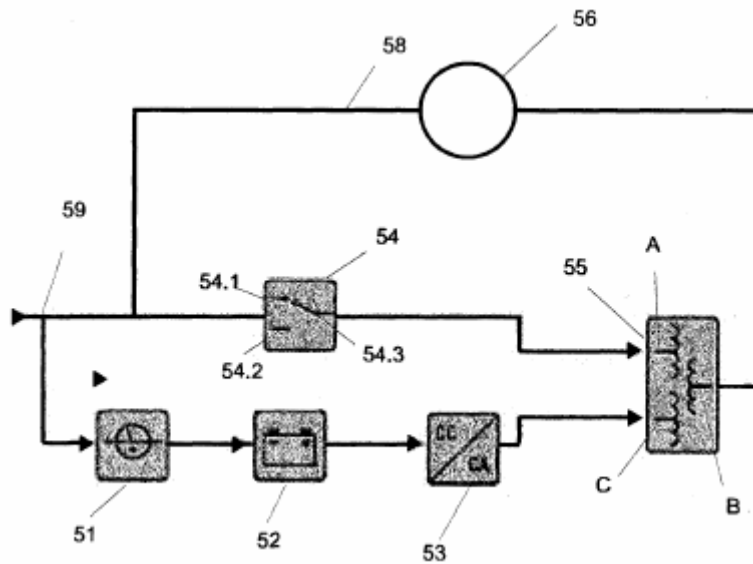

Figure 5 - shows a fourth embodiment of the self-powered system for generating electricity of the present invention;

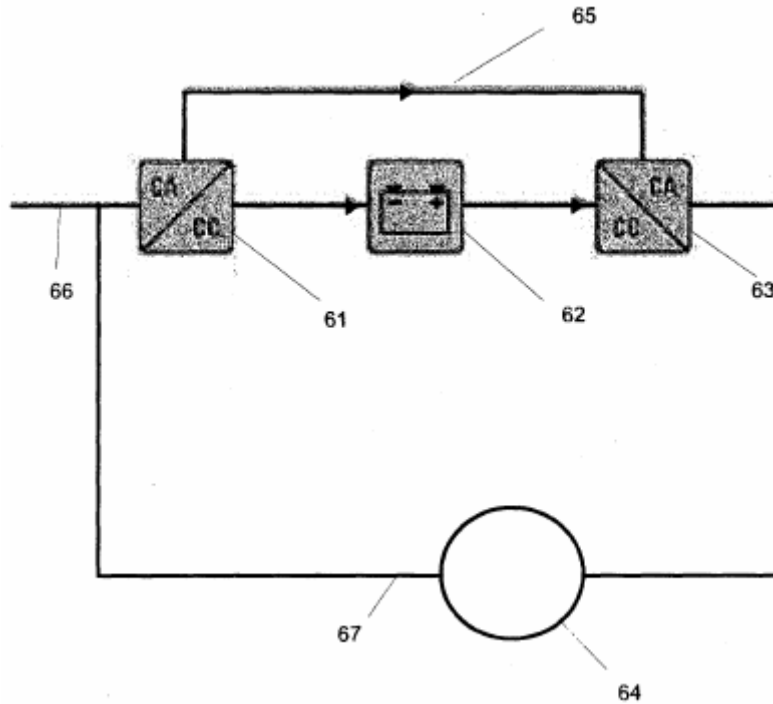
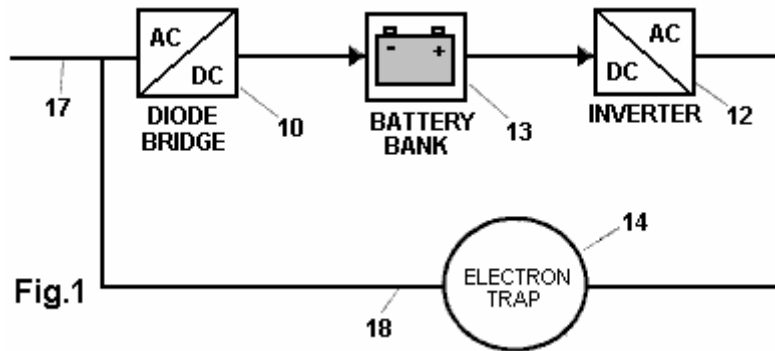

Figure 6 - shows a fifth embodiment of the self-powered system for generating electricity of the present invention;

Detailed description of the Invention:

There are different ways of closing the self-feeding cycle depending on the circuit configuration chosen. Some of these arrangements are shown in **Figures 2 to 6**, wherein the main circuitry continues to oscillate, continuously generating instant electricity.



As shown in **Fig.1**, the self-powered system for generating electricity comprises a basic circuit consisting of a rectifier (AC/DC converter) **10** which is connected in series to an inverter (DC/AC) **12**. A bank of batteries **13** is connected between the rectifier **10** and the inverter **12**. The output from the DC/AC inverter **12**, connects to an electron-trap **14** which can extract electrons from space (as described in Brazilian patent application No. BR1020120008378 of 13th January 2012) or alternatively, extracts electrons from the Earth (as described in Brazilian patent application No. BR1020120008386 of 13th January 2012).

When connected, the battery bank **13** provides power to the DC/AC inverter **12** which converts the direct current into alternating current and provides current to the electron-trap **14**. The output of the electron trap **14** is passed through wire **18**, to the AC/DC bridge rectifier **10**, which keeps the battery bank charged as well as powering the DC/AC inverter **12**. Additional power is passed to external equipment through wire **17**.

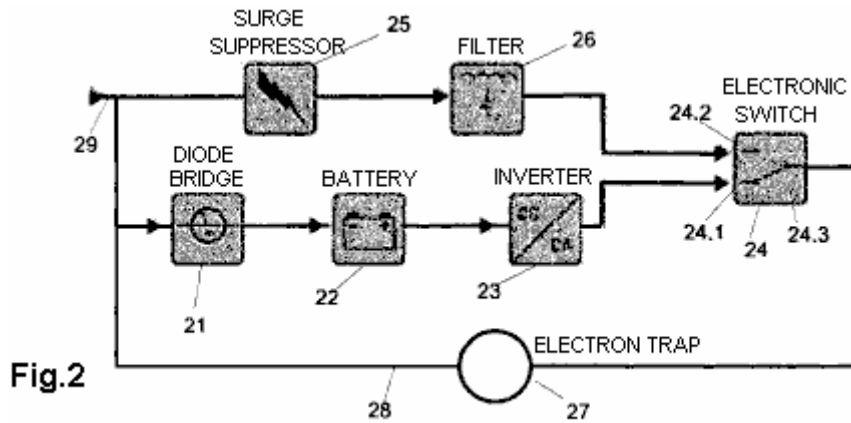

Fig.2

Fig.2, shows another embodiment of the system of this self-powered electric power generation equipment. It comprises a typical Uninterruptible Power Supply circuit of a battery charger (AC/DC converter) **21** connected to a drive device (a DC/AC inverter) **23** and between them, a battery bank **22** forming the basic circuit. Additional devices are an electron-trap **27** which may collect free electrons from space (as defined in Brazilian patent application No. BR1020120008378 of 13th January 2012) or, alternatively, collects electrons from the Earth (as described in Brazilian patent application No. BR1020120008386 of 13th January 2012). The 3-phase electronic switch **24** normally connects **24.1** to **24.3** connecting the electron trap **27** to inverter **23**. Connected in parallel is the surge suppressor **25**, which, when activated, via filter **26**, causes switch **24** to disconnect the **24.3** to **24.1** link and instead, connect **24.3** to **24.2**.

An alternative arrangement for use in emergency situations, is to use the system no longer self-powered. For this, the system is comprised of a power input from an external power source, directly to the interconnection point **29** to provide power to surge suppressor **25**, which provides power to feed the power output point **28** in order to power external loads. When the electron-trap **27** is turned off, the electronic transfer switch **24** reverts to its default position which connects point **24.1** to point **24.3** causing the circuit to function, once again, in its self-feeding mode. As soon as the electron sensor **27** provides sufficient power to the over-voltage sensor **25**, it operates the transfer switch **24** through filter **26**, ending the self-feeding phase and supplying energy directly to the power output point **28**, in order to feed external loads.

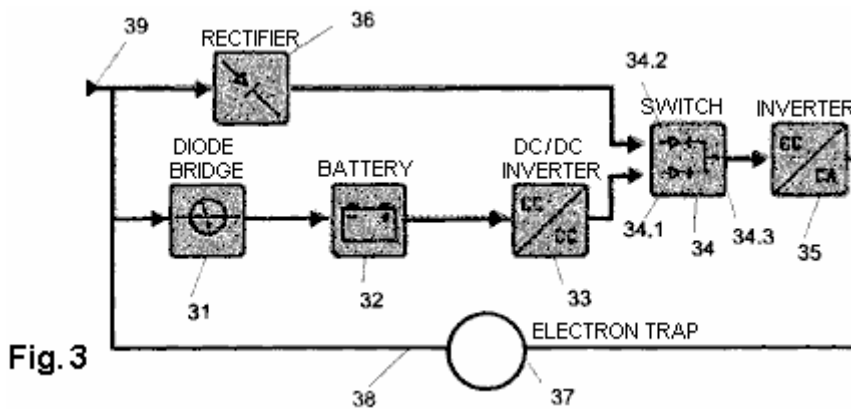

Fig.3

Fig.3 shows another embodiment of the self-powered system for generating electricity, comprising a device which includes the basic circuit of a typical Uninterruptible Power Supply, consisting of a battery charger (AC/DC converter) **31** connected to a drive device (inverter DC/AC) **35** and attached to them, a battery bank **32**. This basic circuit together with other devices is connected to an electron-trap **37** for collecting free electrons from surrounding space or, alternatively, an Earth-connected electron trap **37**. We have then, a bank of batteries **32** connected to the DC/DC converter **33**, which is connected to the phase transfer switch **34 / 34.1** which is connected to point **34.3**, which connects to the inverter **35**, and so, the electron-trap **37**.

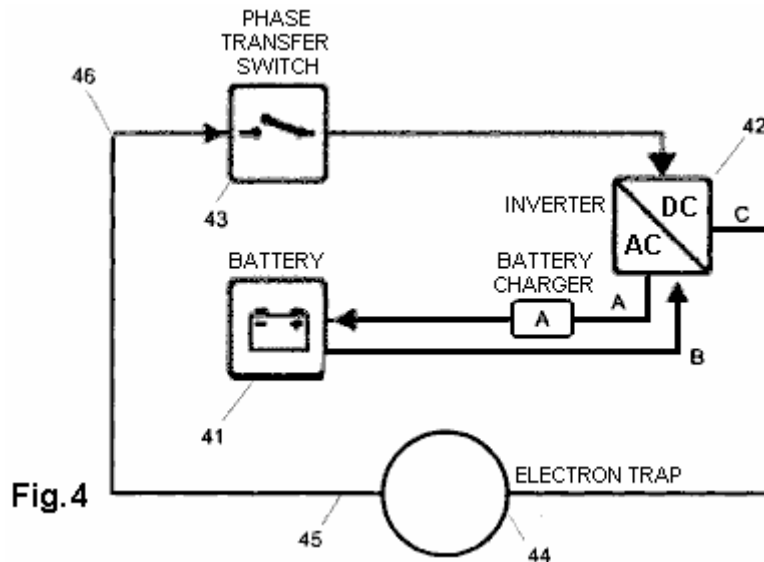

Fig.4

Fig.4 shows another embodiment of the system for self-powered electricity generation which is comprised of a basic circuit of a typical uninterruptible power supply, consisting of a battery charger (AC/DC converter) **A** connected to an inverter (DC/AC) **42** and attached to them, battery bank **41**, and this basic circuit together with other devices are connected to a free space electron-capture device **44** or an earth-connection electron-trap **44**. Comprising thus, a battery charger **A** connected to a battery bank **41**, which is connected in series with inverter **42** at point **B** which is in series with point **C** of inverter **42** which is in series with the electron sensor **44**, which is in series with the phase transfer switch **43** via the three-phase load output connection point **45**. The phase transfer switch **43** is in series with the inverter **42**, which is connected in series the (AC/DC converter) battery charger **A** feeding the battery bank **41**.

An alternative construction for use in emergency situations, in which the system ceases to be self-powered, the system may include power input from an external power source, via the interconnection point **46**, thus providing electricity output **45**, to power external loads. The battery bank **41** provides power to the inverter **42** which converts the direct current into alternating current and feeds the electron trap **44**. The phase transfer switch closes when the batteries need recharging.

Sensor **44** captures electrons, producing alternating current, which feeds the phase transfer switch **43** with alternating current input power. The phase transfer switch **43** feeds the inverter **42** which charges the batteries, closing the self-powering loop which provides power at the output **45**, feeding both the power input and any external loads.

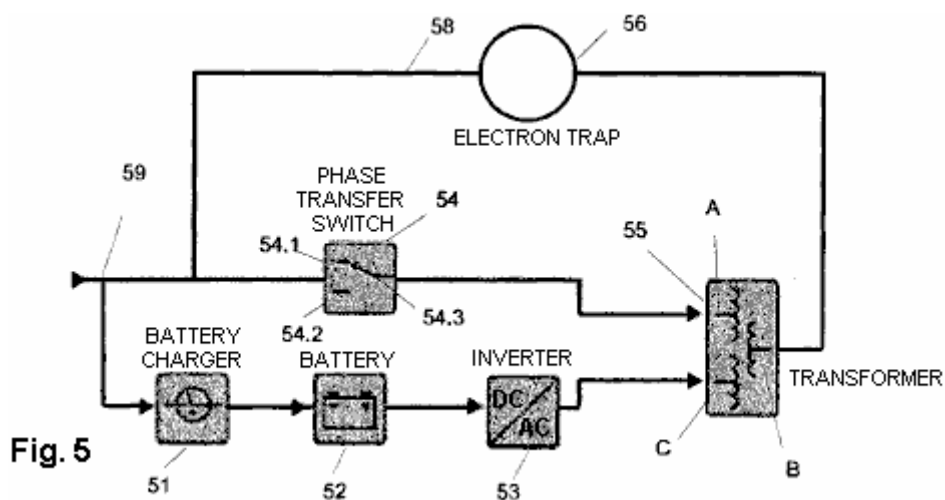

Fig.5

Fig.5 shows another embodiment of the system for self-powered electric power generation equipment comprising a circuit which includes a typical uninterruptible power supply comprising a battery charger (AC/DC converter) **51** connected to a DC/AC inverter **53** and attached to them, a battery bank **52**. This basic circuit together with other devices are connected to a space free-electron capture device **56** (as defined in Brazilian patent application No. BR1020120008378 of 13/1/12) or, alternatively, an earthed free-electron collector **56** (as defined in Brazilian

patent application No. BR1020120008386 of 13/1/12). This then comprises a battery charger 51 which is connected in series with a battery bank 52, which is connected in series with the inverter 53, which is connected in series with the transformer 55 at its point C, which is in series with its point B which is in series with the electron collector 56, which is in series with the battery charger 51 which is connected to the load exit point 58, which is also the circuit entry point 59, which is in series with the phase transfer switch 54 section 54.1, which is connected to terminal 54.3, which is in series with point A of the transformer 55 which exits at point B. Points A and 54.3 as well as the parallel points 54.1 and 54.2, are all parallel to the battery charger 51, the battery bank 52, the inverter 53 and to point C of the transformer 55.

An alternative construction for use in emergency situations, in which the system ceases to be self-powered, the system may include an external power input point 59, allowing phase transfer switch 54 to provide power output 58, to feed external loads. Battery bank 52 provides power to the inverter 53, which converts the direct current into alternating current, feeding point C of the transformer, which comes out at points B and A of the transformer 55. Point B of the transformer feeds the electron-trap 56 producing alternating current which feeds the battery charger 51, recharging the battery bank 52.

The battery charger 51 is connected in parallel with the transfer switch 54 via connection points 54.1 and 54.3, feeding point A of the transformer, which comes out at point B. Point A of the transformer and the switch transfer points 54.3 and 54.1 are in parallel to the battery charger 51, the battery 52, the inverter 53 and point C of the transformer 55.

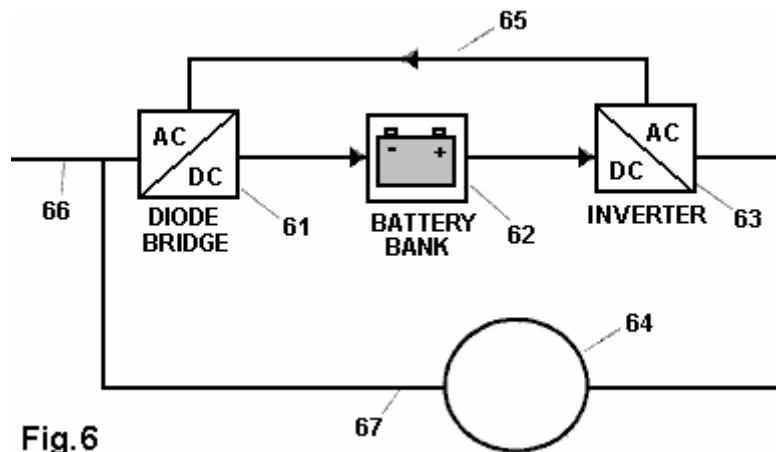

Fig.6

Fig.6 shows another embodiment where a rectifier 61 is connected to an inverter 63 and a battery bank 62, and to a space free-electron trap 64 or alternatively, an earth electron trap 64 comprising thus, a delta (AC/DC) converter 61, which is connected in series to a battery bank 62, which is connected in series with the (DC/AC) inverter 63, which is in series with the electron collector 64 which is connected in series with the delta converter (AC/DC) 61 whose AC part is in series with the alternating AC current inverter 63 via a connecting wire 65 which is in parallel with the DC part of the delta converter 61 with the battery bank 62 and the DC part of inverter 63. An alternative construction for use in emergency situations, in which the system ceases to be self-powered, the system may comprise a power input from an external power source, via the interconnection point 66 connected to the delta converter 61, the output 67 supplying power, to the external loads.

Battery bank 62 provides power to the inverter 63, which converts the direct current into alternating current, powering the free-electron collector 64. The captured electrons from collector 64 form an alternating current which feeds the delta converter 61 via an output power load wire 67.

The alternating part of the three-phase delta converter 61 is fed with alternating current from inverter 63 via connecting wire 65, which is connected in parallel to the continuous DC delta converter 61, which feeds the battery bank 62 and with the continuous portion the inverter 63, closing the cycle of self-feeding and supplying power at the output 67, which is the output power point.

Having described examples of preferred embodiments, it should be understood that the scope of the present invention encompasses other possible forms of construction, using the electron collectors connected to a basic circuit of a typical uninterruptible power supply of energy, known as a UPS, comprising a rectifier device (an AC/DC converter) 10, connected to one inverter (DC/AC converter) 12, and attached between them, an energy storage device (typically, a battery bank).

A very important part of the above patent is the device described as a “collector of free-electrons”, either from the earth or from space. We have to go to the patent applications mentioned above to find the details of these designs:

Application Number: BR2013/000015, Publication Date: 07/18/2013, Filing Date: 01/11/2013

Assignee: EVOLUÇÕES ENERGIA LTDA (Rua Santa Tereza 1427-B Centro - Imperatriz, MA- CEP -470 - Maranhão, 65900, BR)

ELECTROMAGNETIC ELECTRON TRAP FOR ELECTRIC POWER GENERATION

Technical Field

The present invention refers to electromagnetic equipment for electric power generation or alternatively for thermal power generation. More specifically equipment capable of producing abundant electricity and thermal energy from a tiny amount of input electrical energy

Description of the Related Art

According to Lenz's law, any induced current has a direction such that the magnetic field it generates opposes the change in magnetic flux which produced it. Mathematically, Lenz's Law is expressed by the negative sign (-) that appears in the formula of Faraday's Law, as follows.

The magnitude of the induced emf (ϵ) in a conducting loop is equal to the rate of change of magnetic flux (Φ_B) with time:

$$\epsilon = - \frac{d\Phi_B}{dt} \quad \text{Equation 1}$$

As an example of application of Faraday's Law, we can calculate the electromotive force induced in a rectangular loop that moves in or out, with constant speed, a region of uniform magnetic field. The magnetic field flux through the surface limited by the loop is given by:

$$\phi = xLB \quad \text{Equation 2}$$

and its variation in time:

$$\frac{\Delta\phi}{\Delta t} = \left(\frac{\Delta x}{\Delta t}\right)LB = vLB \quad \text{Equation 3}$$

So:

$$\epsilon = vLB \quad \text{Equation 4}$$

and if the coil has a resistance (R) and the induced current:

$$i = \frac{\epsilon}{R} = \frac{vLB}{R} \quad \text{Equation 5}$$

A conductor traversed by an electric current immersed in a magnetic field undergoes the action of a force given by:

$$F = IL \times B \quad \text{Equation 6}$$

Thus, the effect of the current induced in the loop appears as forces F_f , and $F - FM$. The first two cancel each other out and the third is cancelled by an external force P_{EXT} needed to maintain the constant speed loop.

As the force FM must oppose the force F_{EXT} , current (i) induced in the loop by varying the magnetic flux must have the meaning indicated in **Fig.3**. This fact is a particular example of Lenz's Law.

Considering the experimental activities discussed with Faraday's law, when a magnet approaches a coil, the induced current in the coil has a direction as shown in **Fig.1**. This generates a magnetic field whose north pole is

facing the north pole of the magnet, that is, the field generated by the induced current opposes the motion of the magnet.

When the magnet is moved away from the coil, the current induced in the coil has a direction opposite to that shown in **Fig.1**, thereby generating a magnetic field whose south pole is facing the north pole of the magnet. The two poles attract each other, that is, the field generated by the induced current opposes the movement of the magnet away from the coil. This behaviour is present in all current power generators, and known as 'engine brake' is highly undesirable as it increases the resistance and so, the energy loss.

When two electromagnetic coils are placed facing each other, as shown in **Fig.2**, there is no current in either of them. At the instant of power-up of one of the coils, the current in the coil, generates an induced current in the second coil. When powered up, the current in the coil goes from zero to its maximum value, and then remains constant.

Thus, when the current is changing, the magnetic field generated by it, (whose north pole faces the second coil) is also changing and so the magnetic flux of this field through the second coil is also changing. Then there is a current induced in the second coil whose sense is such that the magnetic field it generates tends to decrease the flow mentioned above, that is, its north pole confronts the north pole of the first field coil.

When the power switch is opened, the current in the first coil drops from its maximum value to zero, and correspondingly its magnetic field decreases. The flux of the magnetic field in the second coil also decreases, and the induced current now flows in the opposite direction. This current flow direction produces an enhancing magnetic field, that is, it has a south pole facing the north pole of the field of the first coil.

Thus, there is a realisation of the principle of conservation of energy, expressed by Lenz's law, wherein any induced current has an effect which opposes the cause that produced it. Assuming that the induced current acts to favour the variation of the magnetic flux that produced the magnetic field of the coil, it would have a south pole facing the north pole of the approaching magnet, causing the magnet to be attracted towards the coil.

If the magnet were then released, it would experience an acceleration toward the coil, increasing the intensity of the induced current and thus create an enhanced magnetic field. This field, in turn, would attract the magnet with increasing force, and so on, with a continuing increase in the kinetic energy of the magnet.

If energy were to be withdrawn from the magnet-coil system at the same rate at which the kinetic energy of the magnet increases, then there would be an endless supply of energy. So it would be a perpetually operating motor, which would violate the principle of conservation of energy. Therefore, it can be concluded that current generators feature a large energy loss during the generation of electricity.

Objectives of the Invention

An objective of the present invention is to contribute to the generation of sustainable energy, proposing an electromagnetic machine capable of producing abundant electricity from an extremely low input of electrical energy.

The above objective and other objectives are achieved by the present invention by a device comprised of at least one electromagnetic field-generating device (without a core or with at least one core) powered by an electrical power source (without a core or with at least one core) having their coils, or sets of coils, wound on at least one common conductive member in a closed circuit which itself has a polarised voltage which is connected to at least one conductive interconnection element which is connected to a grounding grid, these interconnections creating a new technical effect, namely, the appearance of an electric current which keeps circulating in a closed conductive loop, and which can therefore be used to power external loads.

The device which is the object of the present invention operates as follows: the electromagnetic field generating device, powered by a power source, produces an electromagnetic field which induces an electric current in a closed conductive circuit, creating an interaction between the magnetic poles of the equipment and the magnetic poles of the earth - through both electromagnetic attraction and repulsion. An endless supply of electrons is drawn from the earth into the conductive closed loop, which is connected to the ground through a conductive interconnected grid. Attracted electrons add to the current already flowing in the conductive closed loop, making power available for driving high-power loads, although the device itself is only supplied with a small amount of power. Thus, advantageously, the device which is the object of the present invention, acts as a trap for electrons from the earth and this allows the generation of electricity.

Advantageously, the present electromagnetic equipment generates either electricity or thermal energy, providing access to this new source of energy is through an electromagnetic field. The interconnections of the components

of the electron-trap of the present invention, cause an advantageous new technical effect, namely, the appearance of an electric current which keeps circling in the conductive closed circuit, with or without voltage being applied and even without a load being connected to the loop - provided that the electron-trap is connected.

The proposed sensor can also be used to generate thermal power, depending on the form in which you want to use the effect of the flow of electrical current produced in this electromagnetic equipment.

For the generation of thermal energy in amounts proportional to the power of the electron-trap, through the movement of electrons in the conductive closed loop itself, the resistance should be increased by increasing the number of turns around the cores in the conductive element of the closed circuit, and in that instance, the coils of the electromagnetic field generating device, will then be made of heat-insulated electrical circuit components, bearing in mind the required temperature which is to be produced. The thermal energy generated by the electron-trap can be used in any application from domestic to industrial applications.

This technology can also be used for various technical purposes in electric machines. By "electrical machines", it should be understood to include: static electrical machines, transformers, ballasts, rotating electrical machines, synchronous machines, dual power supply machines, current rectifiers in synchronous cascade, external pole machines, synchronous current machines alternating current machines and/or direct current machines, electronic equipment and electrical resistances. The capture of electrons can provide single-phase, two-phase or three-phase supplies, operating at low, medium or high voltage.

The capture of electrons by induction, does not impact on the environment. The fact is that we use as the capturing force, only a negligible amount of electricity relative to the current captured by the sensor. The relationship between power input and the quantity of electricity generated by the electron-trap is at least 1 to 100, that is, for each 1 watt provided to the sensor, there is at least 100 watts of power available for external loads. This relationship, however, is not limited, as it depends on the mounting of the electron-trap and the objectives of the circuit, and so, the generated power can be greater than 100 times the input power.

Another advantage of the earthed electron- trap proposed in the present invention is that the electron-trap can transport electrons from point "A" to point "B" without a voltage drop across the closed-loop conductive element - if it is biased with a voltage - regardless of the distance between the points depending on the strength and quantity of the electromagnetic field generating devices. It is also possible to transport electrons when the conductive element in a closed circuit is itself not polarised. Thus, the electric current is transported without voltage, just by the magnetic field formed between the device and the generator of the electromagnetic field.

Brief description of the Drawings

The present invention will now be described with the aid of drawings, but the design is not limited to the implementations shown in these drawings, although they show other details and advantages of the present invention.

The figures show:

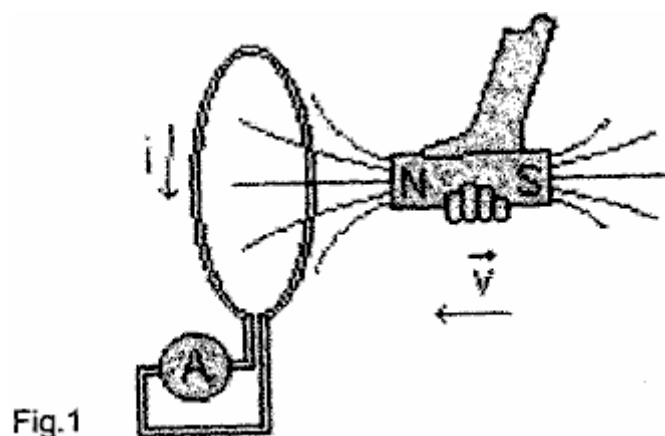

Fig.1 - illustrates Faraday's law.

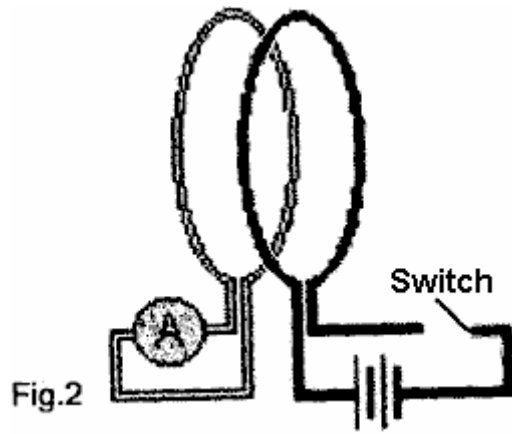

Fig.2 – is a representation of Faraday's law.

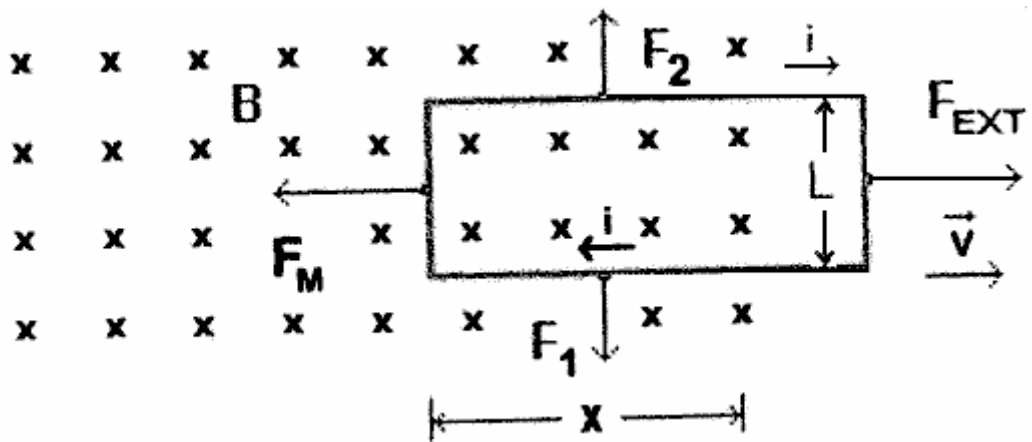

Fig. 3 – is a representation of Faraday's law.

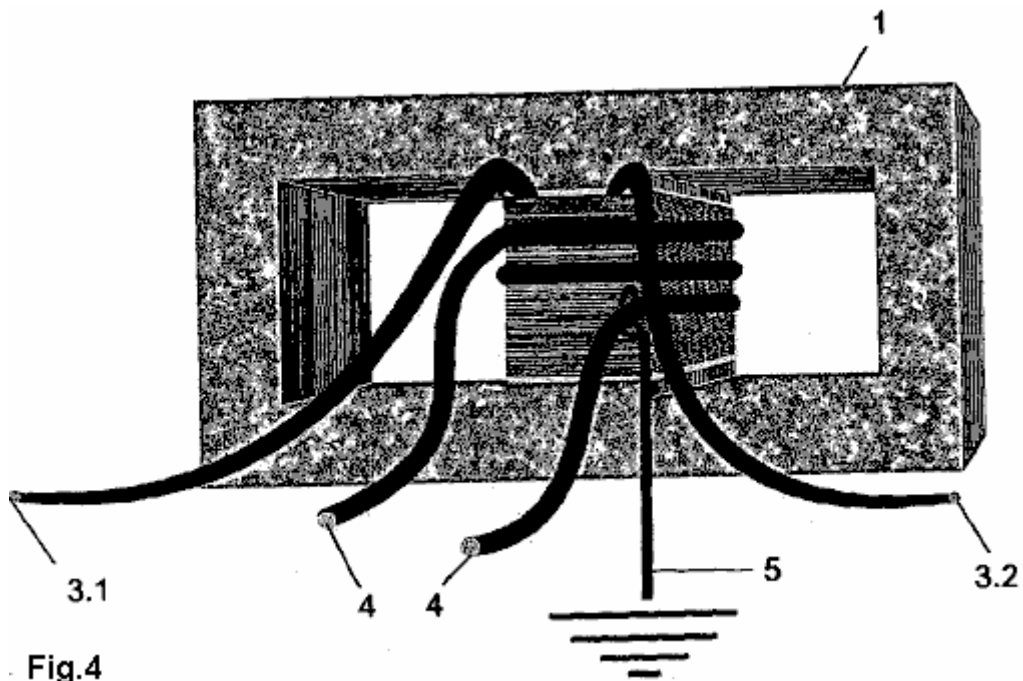

Fig. 4 - is a perspective view of an electron-trap with a single phase coil.

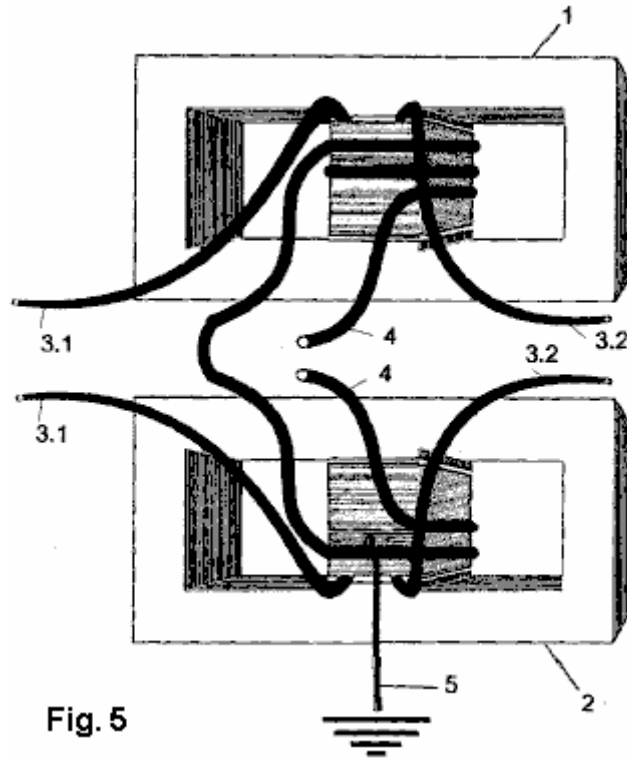

Fig. 5

Fig.5 – is a perspective view of a single-phase electron trap with two coils.

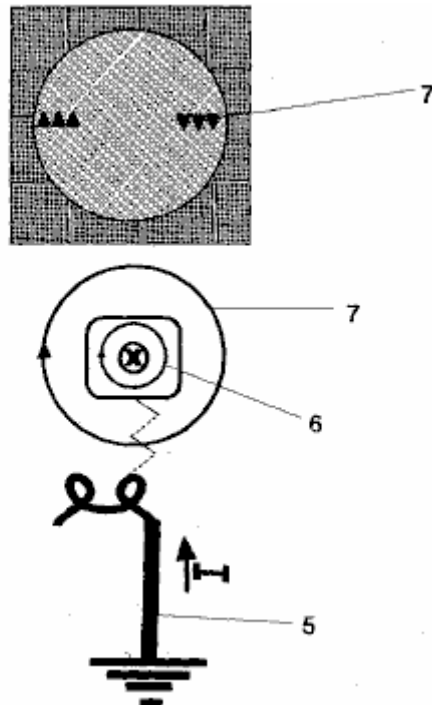

Fig. 6

Fig.6 - is a representation of the effect of electromagnetic flux in the coils around the cores of the electron trap.

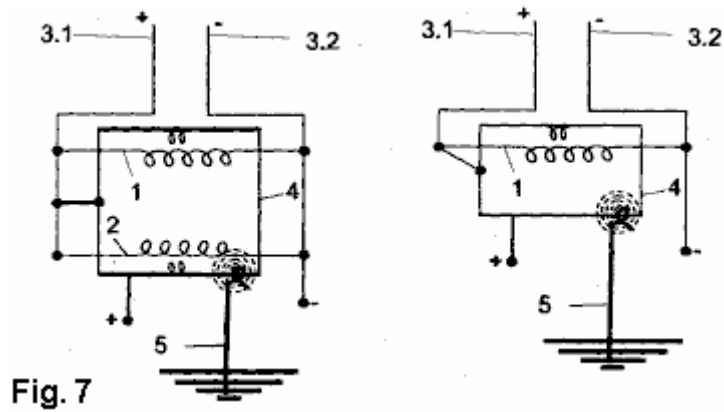

Fig. 7

Fig.7 - is a representation of an electrical circuit with two coils of the link/coil conductor polarised.

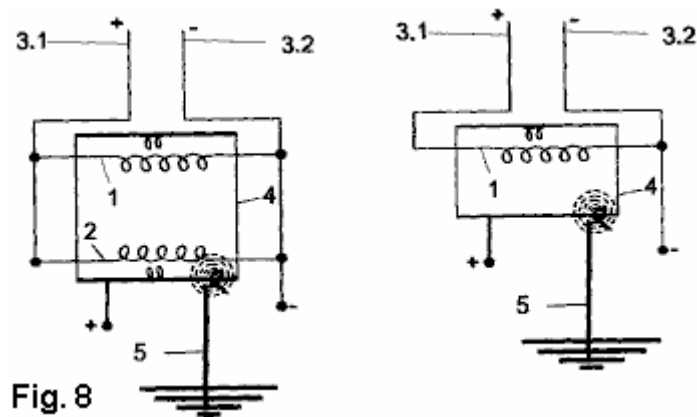

Fig. 8

Fig.8 - is a representation of an electrical circuit with two coils of the link/coil conductor not polarised.

Detailed Description of the Drawings

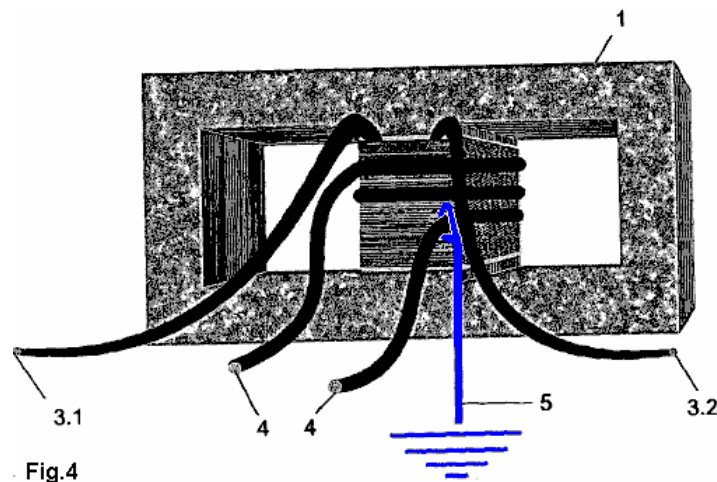

Fig.4

Fig.4 shows one of several types of electron-trap proposed by the present invention, where the electron-trap is single-phase and consists of at least one electromagnetic field-generating device with at least one set of coils, in this case it happens to be an electromagnetic type coil with one common magnetic core, but it could alternatively have any number of windings of any kind and shape. However, the electron-trap proposed by the present invention can be constructed with a different type of electromagnetic field generating device, such as an electromagnetic inductor or magnet of any type or shape, or any combination of them, and in unlimited numbers for each phase of the electron trap.

When winding these coils, for example, coil 4-4, each coil must have at least one complete turn, preferably two turns if the objective is to generate electricity, and preferably four turns if the objective is provide thermal energy. The number of turns in the coils wound around the common core, is directly related to the amount of current to be generated.

At least one conductive interconnection element, in this case the driving member 5 - which can be copper or any other suitable conductive, material whether insulated or not insulated, connects or loop-links wire 4 to the ground grid. The connection between the conductor 5 and wire 4 is by electromagnetic induction. Winding 4 is also the power supply for the loads which are to be powered by the captured electrons.

Also in Fig.4, the power wires 3.1 and 3.2 (live phase and neutral) have an input from an external power coil 1 which can be energised from any external source of electricity such as a power grid. The trapped electrons can be configured to supply DC or AC current. Thus, if the coil 1 power source is alternating electrical current - AC, then the electron-trap provides alternating electrical current. If the power source is continuous electrical current - DC, then the electron-trap provides continuous electrical current - DC. The electrical supply provided by the trapped electrons can be single-phase, two-phase or three-phase, and at low, medium or high voltage.

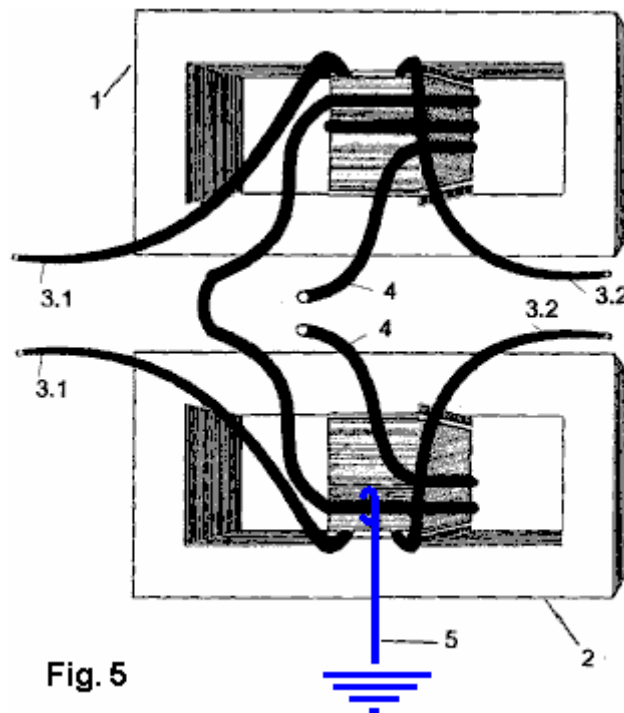

Fig.5 shows an electron-trap with two single-core phase coils: 1 and 2, although these coils may be of any type and shape. However, the electron-trap proposed by the present invention can be constructed with other types of electromagnetic field generating device, with at least one electromagnetic inductor or electromagnet which can be of any type and shape, with any combination of them, and in unlimited quantities in each phase of the electron-trap.

The coils on frames 1 and 2 may have other shapes, but they must each have at least one complete turn, particularly in coil 4. The number of turns in this winding are directly related to the amount of current to be generated. This coil also makes the interconnection between the coils 1 and 2 forming the link between their two cores.

At least one conductive interconnection element, in this case the driving member 5 - which can be copper or any other suitable conductive, material whether insulated or not insulated, connects or loop-links wire 4 to the ground grid. The connection between the conductor 5 and wire 4 is by electromagnetic induction.

In electron-traps which have numerous sets of coils 1 and 2, the ends of all of the power-supply conductors 3.1 can all be connected to each other, and all of the 3.2 conductor ends may be connected together. Thus, all of the coils 1 and 2 can be fed exactly the same voltage. The power to energise coils 1 and 2 can be provided from any external source of supply of electricity such as a power grid.

In electron-traps which have numerous coils 1 and 2, a single coil winding 4 connects the cores of all of the coils 1 and 2.

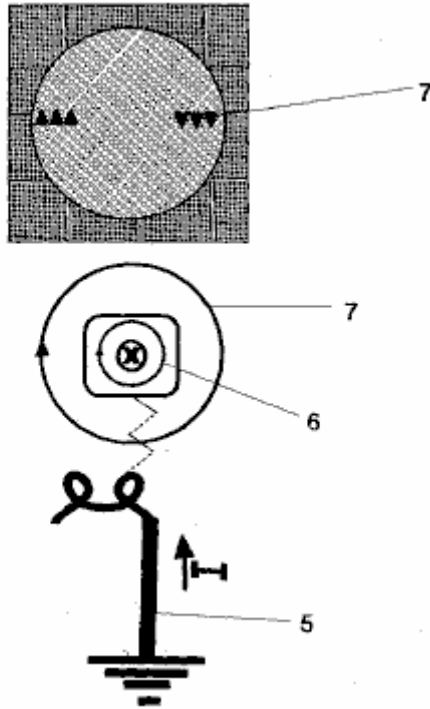

Fig. 6

The diagram shown in Fig.6, illustrates the magnetic induction 6 around the core "X" of the coil 1. This induction causes electrical current flow in the conductor coil link 7/4, attracting electrons from the earth, through the conductive member 5, to the magnetic field of the electron-trap, where those electrons are added to the current generated by induction in the link coil 4 conductor loop circulating between north and south magnetic poles.

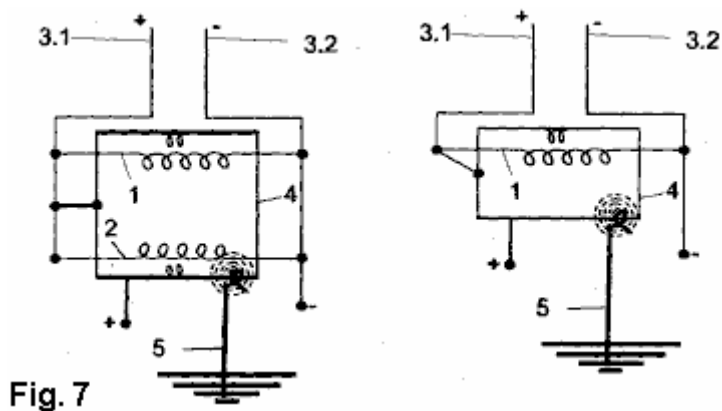

Fig. 7

Fig.7 shows how the connections should be made in one version of the electrical circuit of the electron-trap proposed in this invention. The diagram shows the electrical circuit of an electron-trap where the link/coil driver 4 is polarised with a voltage. This is one form of construction for an electron-trap which has two coils 1 and 2, where a link/coil loop conductor 4 is biased with a voltage, that is, there is a link connecting the coil conductors 4 of a power supply 3.1 or 3.2, whatever the stage.

In this way, earth electron-traps, by adopting this circuit, that is, with the link/conductor loop 4 and polarised voltage on coils 1 and 2, besides being used as a power source for external loads, can also be used for thermal power generation.

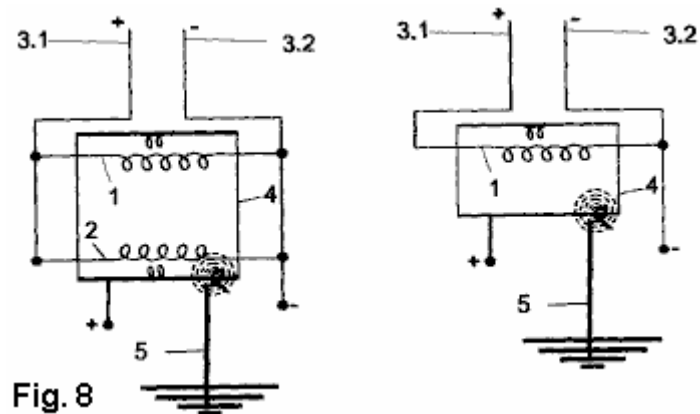

Fig. 8

Fig.8 shows how connections should be made in another electric circuit electron-trap proposed in this invention. the circuit illustrates a circuit of an electron-trap with a non-polarised link / coil driver **4**. This is one form of construction of the electron-trap where a link / coil conductor **4** of the spiral conductor coils **1** and **2** is not polarised, that is, there is no such link connecting conductor / conductor coil conductors **4** of a coil **3.1** or **3.2**.

Thus, earth electron-traps adopting this circuit, that is, with the link coil not polarised, the current flows without there being voltage in the link/coil conductor **4** joining the first and second coils by electromagnetic induction. They can also be used for generating thermal energy.

The structure of the circuit - in the open or closed coils **1** and **2**, and always in the closed link / loop lead **4** - makes it possible to generate current by induction and electron capture by electromagnetism on the link conductor **4** - where current is generated and stays in motion with or without voltage, as the coils **1** and **2** are being fed. Thus, the present invention provides a new concept for electrical energy generation, since it is obtained from an electric current circling without consumption and even without an output load being attached to it.

Additionally, because the induced electrical current flows regardless of the voltage present, it can be used as a current stabiliser for electrical networks whether they be single-phase, two-phase or three-phase, with low, medium or high voltage.

ELECTROMAGNETIC DEVICE FOR CAPTURING FREE SPACE ELECTRONS TO GENERATE ELECTRICITY

Application Number: BR2013/000014

Publication Date: 07/18/2013

Filing Date: 01/11/2013

Assignee: EVOLUÇÕES ENERGIA LTDA (Rua Santa Tereza 1427-B Centro - Imperatriz -, MA - CEP -470 - Maranhão, 65900, BR)

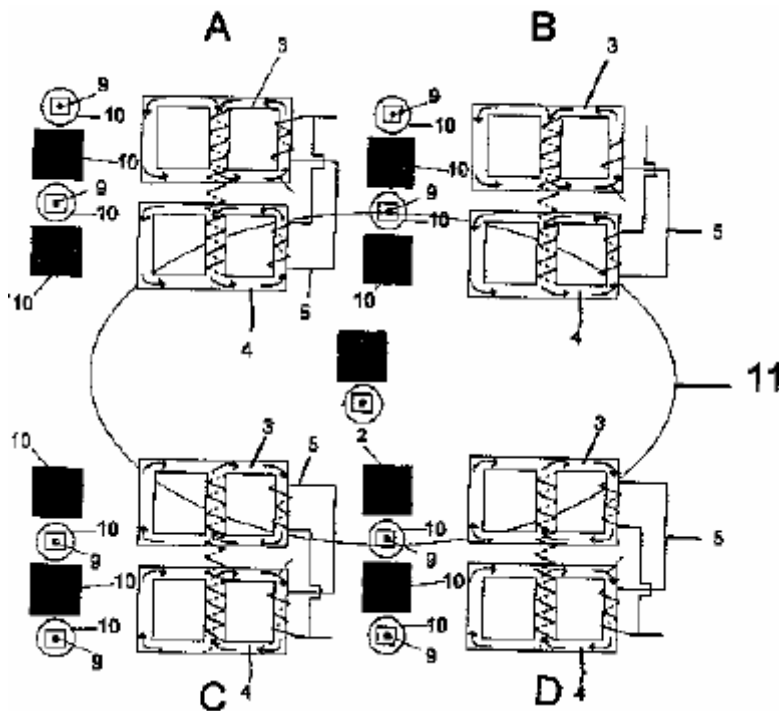

Abstract:

The invention relates to a device that comprises at least three sets (A, B, C, D) of at least one device for generating an electromagnetic field (3) and (4), powered by an electricity source (without a core or with at least one core) the cores thereof or any extension thereof, preferably the windings or sets of windings thereof, being surrounded by at least a single conductive element forming a polarised and energised closed-circuit (5), the sets of electromagnetic-field generating devices (3) and (4) being linked together by their opposing poles to encourage the interaction of their electromagnetic fields, which ideally, are located between two hollow metal hemispheres (1) so as to concentrate and enhance the electromagnetic fields, these interconnections causing, as a novel technical effect, the emergence of an electrical current that circulates, with or without voltage, in the conductive element forming a closed-circuit (5) - even if no load is connected.

Description:

"ELECTROMAGNETIC EQUIPMENT FOR FREE ELECTRON-CAPTURE FROM SPACE, FOR ELECTRICITY GENERATION".

Technical Field

The present invention relates to electromagnetic equipment for electrical power generation and/or thermal power generation. More specifically, equipment capable of producing abundant electricity and thermal energy from a tiny input of electrical energy.

Description of the Related Art

According to Lenz's law, any induced current has a direction such that the magnetic field it generates opposes the change in magnetic flux that produced it. Mathematically, Lenz's Law is expressed by the negative sign (-) that appears in the formula of Faraday's Law, as follows.

The magnitude of the induced emf (ϵ) in a conducting loop is equal to the rate of change of magnetic flux (Φ_B) with time:

$$\epsilon = - \frac{d\Phi_B}{dt} \quad \text{Equation 1}$$

As an example of application of Faraday's Law, we can calculate the electromotive force induced in a rectangular loop that moves in or out, with constant speed, a region of uniform magnetic field. The magnetic field flux through the surface limited by the loop is given by:

$$\phi = xLB \quad \text{Equation 2}$$

and its variation in time:

$$\frac{\Delta\phi}{\Delta t} = \left(\frac{\Delta x}{\Delta t}\right)LB = vLB \quad \text{Equation 3}$$

So:

$$\epsilon = vLB \quad \text{Equation 4}$$

and if the coil has a resistance (R) and the induced current:

$$i = \frac{\epsilon}{R} = \frac{vLB}{R} \quad \text{Equation 5}$$

A conductor traversed by an electric current immersed in a magnetic field undergoes the action of a force given by:

$$F = IL \times B \quad \text{Equation 6}$$

Thus, the effect of the current induced in the loop appears as forces F_f , and $F - FM$. The first two cancel each other out and the third is cancelled by an external force P_{EXT} needed to maintain the constant speed loop.

As the force FM must oppose the force F_{EXT} , current (i) induced in the loop by varying the magnetic flux flux must have the meaning indicated in **Fig.1**. This fact is a particular example of Lenz's Law.

Considering the experimental activities discussed with Faraday's law, when a magnet approaches a coil, the induced current in the coil has a direction as shown in **Fig.2**. This generates a magnetic field whose north pole is facing the north pole of the magnet, that is, the field generated by the induced current opposes the motion of the magnet.

When the magnet is moved away from the coil, the current induced in the coil has a direction opposite to that shown in **Fig.2**, thereby generating a magnetic field whose south pole is facing the north pole of the magnet. The two poles attract each other, that is, the field generated by the induced current opposes the movement of the magnet away from the coil. This behaviour is present in all current power generators, and known as 'engine brake' is highly undesirable as it increases the resistance and so, the energy loss.

When two electromagnetic coils are placed facing each other, there is no current in either of them. At the instant of power up one of the coils, the current in the coil, generates an induced current in the second coil. When powered up, the current in the coil goes from zero to its maximum value, and then remains constant.

Thus, when the current is changing, the magnetic field generated by it, (whose north pole faces the second coil) is also changing and so the magnetic flux of this field through the second coil is also changing. Then there is a current induced in the second coil whose sense is such that the magnetic field it generates tends to decrease the flow mentioned above, that is, its north pole confronts the north pole of the first field coil.

When the power switch is opened, the current in the first coil drops from its maximum value to zero, and correspondingly its magnetic field decreases. The flux of the magnetic field in the second coil also decreases,

and the induced current now flows in the opposite direction. This current flow direction produces an enhancing magnetic field, that is, it has a south pole facing the north pole of the field of the first coil.

Thus, there is a realisation of the principle of conservation of energy, expressed by Lenz's law, wherein any induced current has an effect which opposes the cause that produced it. Assuming that the induced current acts to favour the variation of the magnetic flux that produced the magnetic field of the coil, it would have a south pole facing the north pole of the approaching magnet, causing the magnet to be attracted towards the coil.

If the magnet were then released, it would experience an acceleration toward the coil, increasing the intensity of the induced current and thus create an enhanced magnetic field. This field, in turn, would attract the magnet with increasing force, and so on, with a continuing increase in the kinetic energy of the magnet.

If energy were to be withdrawn from the magnet-coil system at the same rate at which the kinetic energy of the magnet increases, then there would be an endless supply of energy. So it would be a perpetually operating motor, which would violate the principle of conservation of energy. Therefore, it can be concluded that current generators feature a large energy loss during the generation of electricity.

Objectives of the Invention

The present invention aims to contribute to the generation of sustainable energy, proposing electromagnetic equipment capable of producing abundant electricity from an extremely low input of electrical energy.

The above objective and other objectives are achieved in the present invention by a device comprising at least three sets of at least one electromagnetic field generating device (without a core or with at least one core) powered by an electrical power source, having their cores or any extension of them, with their coils or sets of coils, wound on at least one common conductive member in a closed circuit which is polarised by a voltage source, and these sets of electromagnetic field generating devices are arranged with their poles in confrontation, to promote the interaction of electromagnetic fields, and, preferably, positioned between two hollow metallic hemispheres, in order to focus and enhance their electromagnetic fields - these interactions cause a new technical effect - the emergence of an electric current which keeps flowing in a closed loop, with or without voltage being applied to that closed loop, current which is capable of powering external loads - even if no load is attached to it.

The device which is the object of the present invention operates as follows: Sets of electromagnetic field generating devices to be powered by an electrical power source, produce an electromagnetic field which induces an electric current in a closed conductive circuit, creating an interaction between the magnetic poles, and through repeated electromagnetic attraction and repulsion, provides an endless supply of electrons to the conductive closed loop itself.

The electrons attracted by this technique, augment the current flowing in the closed conductive loop, which provides the current to power external loads of high power, in spite of the fact that the device itself is supplied with only a small level of power. Thus, advantageously, the device which is disclosed in the present invention forms a trap for electrons from space, resulting in the generation of electricity. The interconnections of the components of the electron-trap cause, a new technical effect, namely, the appearance of an electric current which keeps circling in a closed circuit, even without any voltage being applied to the closed circuit, and even without a load being connected to it. The present electromagnetic equipment generates electricity or thermal energy, providing access to this new source of energy through the use of an electromagnetic field.

The proposed sensor can also be used for the generation of thermal energy depending on the form of circuit which is to be used, resulting from the flow of electric current produced by this electromagnetic equipment.

This field generates a flow of electric current induced by electromagnetic coils, which appears in the linking interconnecting devices generating electromagnetic fields with electromagnets, inductors or magnets. This chain operates in a manner favourable to the variation of the magnetic flux produced by the magnetic field in the electron-trap. Thus, it creates a north pole and a south pole, providing an endless supply of electric current without resistance between the links which interconnect the devices which are generating the electromagnetic fields. So, induced electric current is generated with or without voltage in the interconnection links of electromagnetic field-generating devices, depending on the connection method of the electrical circuit of the electron-trap.

The free-electrons collected by the space electron-trap can form alternating current (AC) or direct current (DC). The ratio of input power to output power is 1 to 100, that is, the generated power can be 100 times greater than the input power when there is at least one link / coil driver between the coils and the inductors or electromagnets. This relationship, however, is not limited to a factor of 100, as it depends on the shape of the electron-trap and its objective.

Another advantage of the free space electron-trap of the present invention is that, with thermal insulation of the components in the electric circuit, it is possible to produce thermal energy at low, medium or high temperature, through the movement of the electrons in the conductors, coils and/or electromagnets. The temperature generated is linked directly to the number of turns in the coils.

Thermal power generation performed by the sensor can be used for boiling and/or evaporation of liquids to be used in other types of energy generation, for example, replacing the use of coal and natural gas.

Another advantage of the proposed electron-trap of the present invention is that the electron-trap can transport electrons from one point "A" to a point "B", without a voltage drop in the link - if it is polarised - regardless of the distance between the points, depending on the strength and quantity of the electromagnetic field-generating devices. It is also possible to transport the electrons when the link devices generating the electromagnetic field are not polarised. In this way, the electric current is conveyed without voltage but only by the magnetic field formed between the coils. This methodology can be used in various fields.

Because of its simple construction, the electron-trap is a simple device which is compact, and performs low-cost power generation which can be used in all types of machinery, equipment and devices of all kinds, and many areas of application which require electricity in order to operate. The electron-trap can have single-phase, two-phase or three-phase output, and can generate electric current at low, medium or high voltage.

Brief description of the Drawings

The present invention will now be described with the aid of drawings, but the design is not limited to the implementations shown in these drawings, although they show other details and advantages of the present invention.

The figures show:

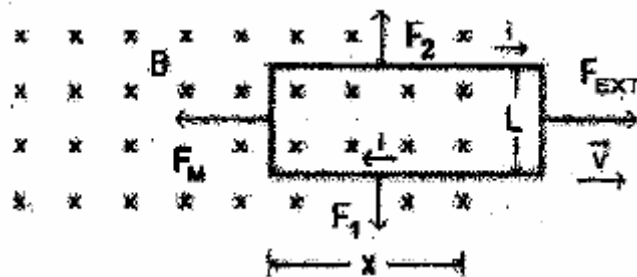

Fig.1 - illustrates Faraday's law.

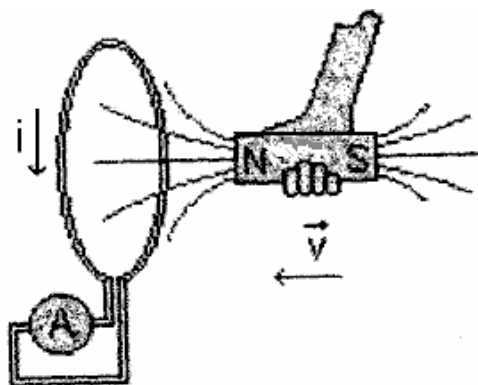

Fig.2 illustrates Faraday's law where a magnet approaches a coil of just one turn..

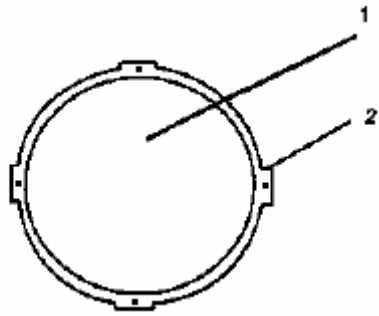

Fig. 3

Fig. 3 is a view of one metallic hemisphere seen from above.

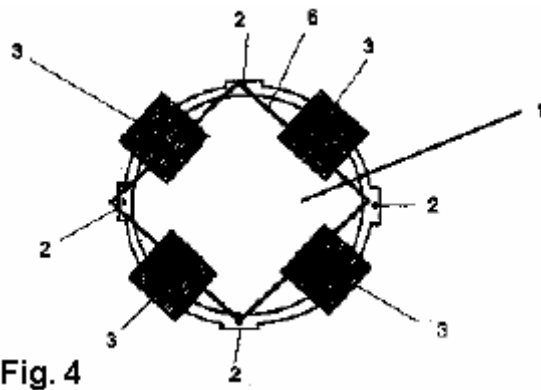

Fig. 4

Fig. 4 is a bottom view of the hemisphere with the coils in place.

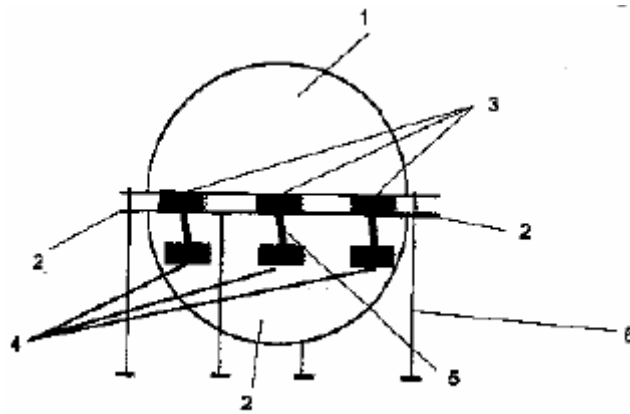

Fig. 5 is a side view of the free-space electron-trap.

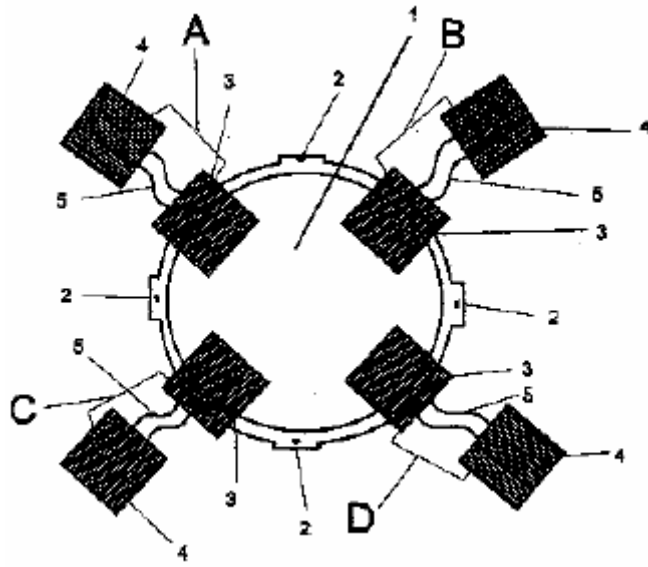

Fig.6 is an underside view of the space electron-trap, with its coils and electromagnets

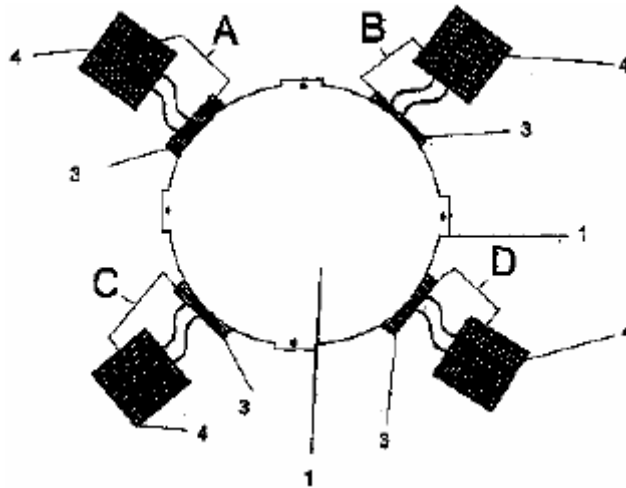

Fig.7 a view from above of the space electron-trap with its coils and electromagnets.

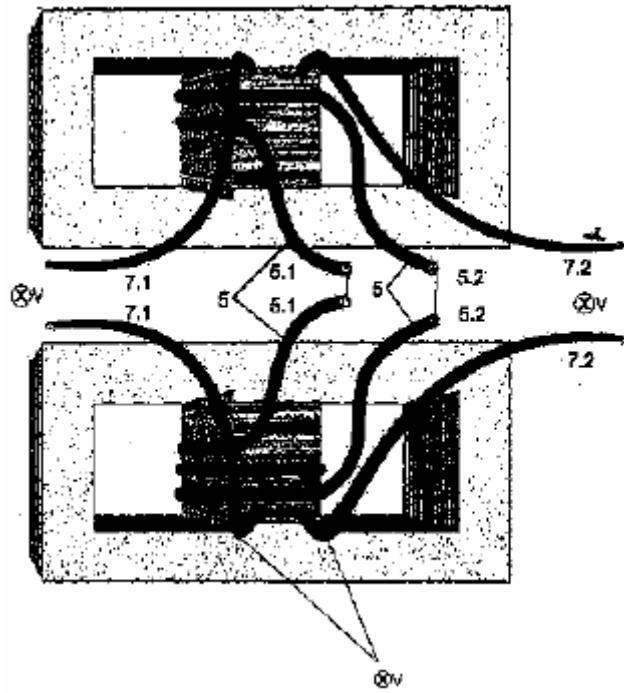

Fig.8 is a perspective view of an electron-trap with its coils.

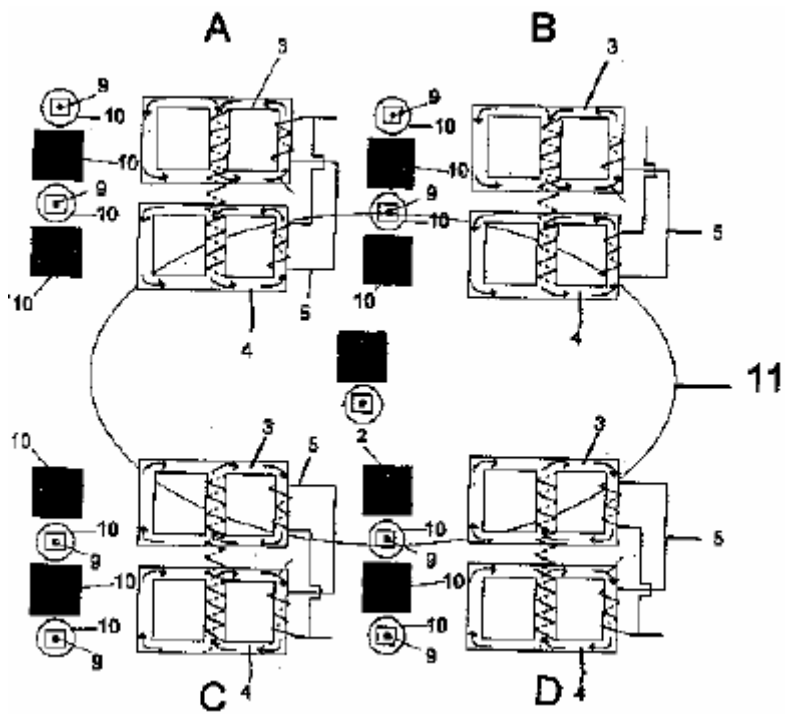

Fig.9 shows the circuit diagram of the device, indicating the effect of electromagnetic field.

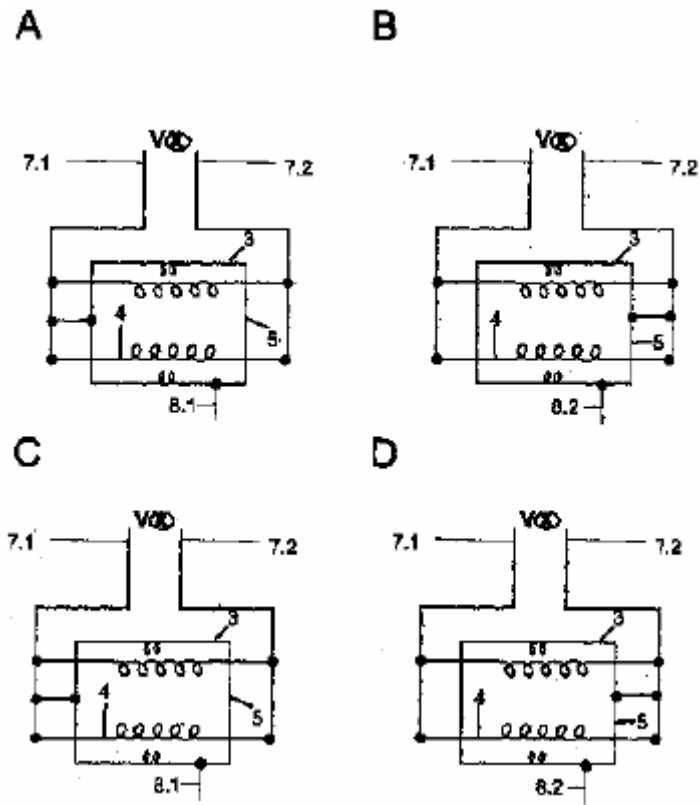

Fig.10 - shows the circuit diagram of the connection of the inductor coils in sets (A, B, C and D).

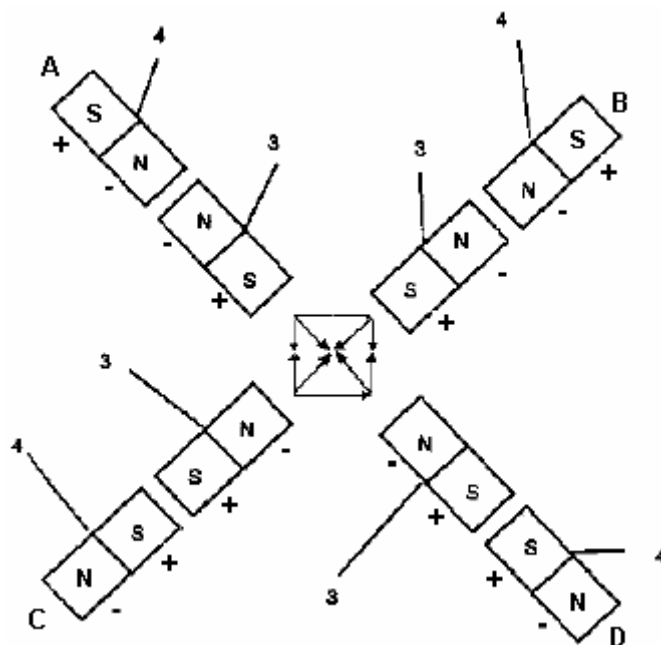

Fig.11 - is an electromagnetic diagram representation of north and south poles of the sets of coils (A, B, C and D).

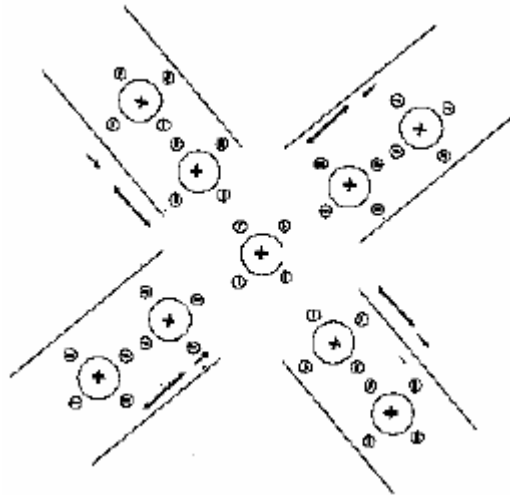

Fig.12 is a representation of the electrons being attracted and repelled by the device.

Detailed Description of the Drawings

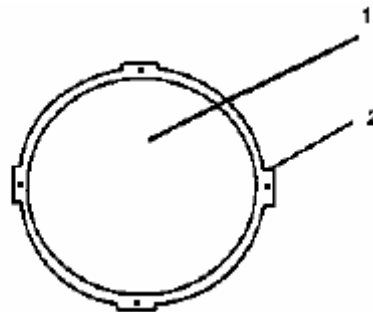

Fig.3

Fig.3 is a top view of one of the two hollow metallic hemispheres 1 which is part of the electron trap of free space proposed in this invention. Hemisphere 1 is preferably made from, but not limited to, aluminium, and it has mounting tabs 2.

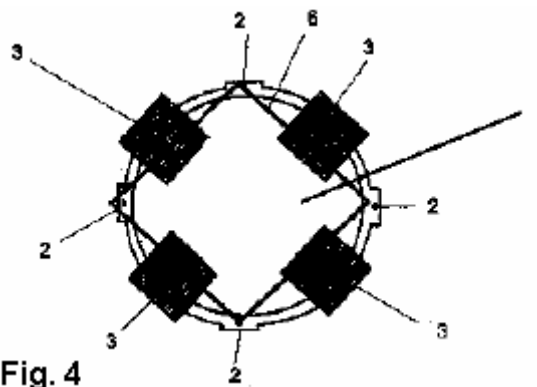

Fig. 4

Fig.4 is a bottom view of metallic hemisphere 1. It has four electromagnetic field generating devices 3, positioned around the hemisphere and fixed to support 6 which is attached to hemisphere 1 by mounting tabs 2.

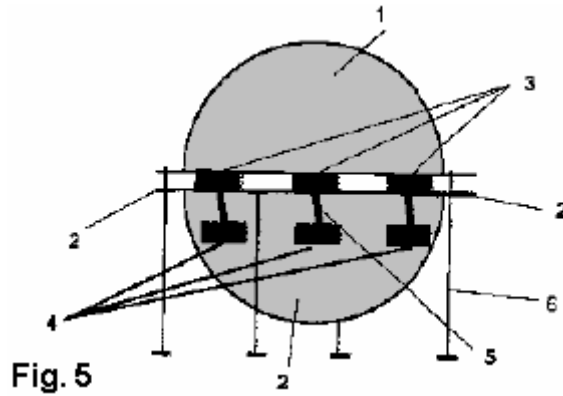

Fig.5 is a side view of the free space electron-trap. It shows the two metallic hemispheres **1** and **2** (which form an imperfect sphere), and three of the coils **3** which are attached to the mounting tabs **2** and three inductors **4** which form the closed circuit itself, and which are attached by conductors **5**, and support member **6** on which are mounted coils **3** and their components.

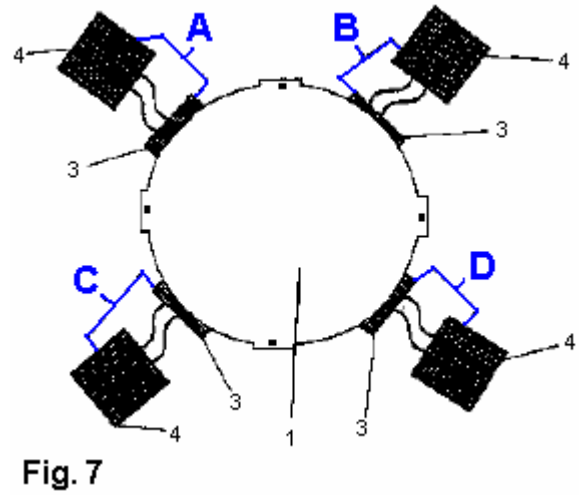
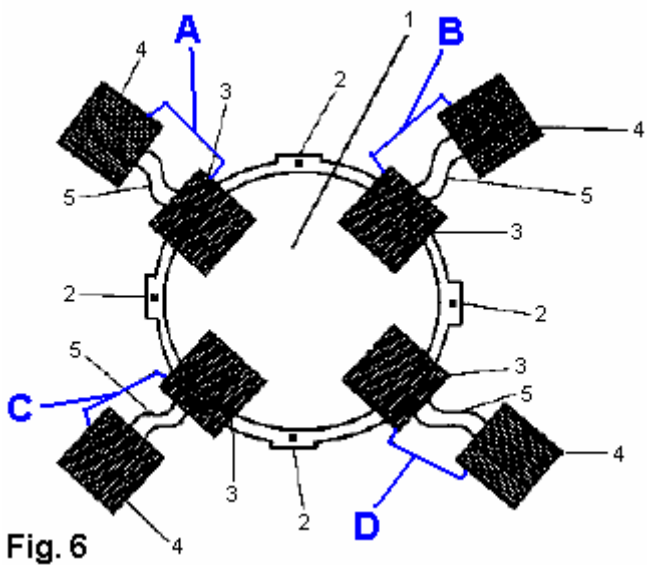

Fig.6 and **Fig.7** show the top and bottom views of the metallic hemisphere **1** which accommodates four coils **3** attached to the holder **6** (not shown) which is secured to the hemisphere **1** by its mounting tabs **2**. **Fig.6** also shows the inductors or electromagnets **4** their corresponding coils **3** and their interconnecting conductors **5**. Each coil **3** and its linked inductor **4** forms a set. In **Figures 6** and **7** there are four such sets, marked **A**, **B**, **C** and **D**. The coils **3**, connected by their links **5**, each have at least one turn, and if the objective is to generate electricity, then preferably two turns, and if the objective is thermal energy, then four turns. The coils **3** may have various different shapes. The number of turns in the coil **3** are directly related to the amount of current to be generated, and the connecting links **5** may be either a single conductor or more than one conductor, the cross-sectional area of conductor **5** being selected to carry the current which is to be generated.

In sets **A**, **B**, **C** and **D**, the link conductors **5** have at least one turn around coils **3**. This winding is connected to the respective electromagnets **4** of each set (**A**, **B**, **C** and **D**) as shown in **Figures 6** and **7**. Please note that the inductors and electromagnets **4** can be any type of inductor, and other types of coil may be used.

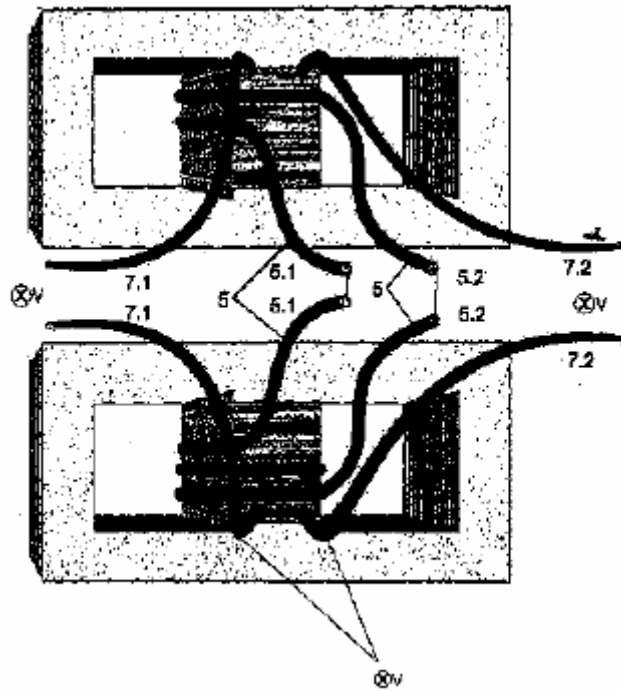

Fig.8 shows the inter-connecting coils **5** for each of the five sets **A, B, C** or **D** linking between coils **3** and **4** in each set. As shown in **Fig.6** and **Fig.7**, the link **5** makes the connection between coils **3** and **4**. This means that the wires marked **5.1** are all connected together, and the wires marked **5.2** are all connected together. Doing this, establishes the interconnection links **5** shown in the drawings. The power supply wires marked **7.1** are connected together as are the wires marked **7.2**. The wires marked **7.1** are connected to the live phase of the external power supply, while the other ends marked **7.2** are connected to the neutral of the external power supply.

In the space free-electron trap of the present invention, the coils **3** can be either single-phase, two-phase or three-phase. Also, the coils **3** may be powered by any voltage (V). The power coil **3** can be energised by any source of electrical energy such as a power grid. The electron-trap can be configured to produce alternating current or direct current. So, if the external power supply is alternating electrical current - AC, then the electron-trap provides an alternating electrical current output. If the power supply is DC, then the electron-trap provides an output of continuous electrical current - DC. The electron-trap can be configured for single-phase, two-phase or three-phase operation, with low, medium or high voltage outputs.

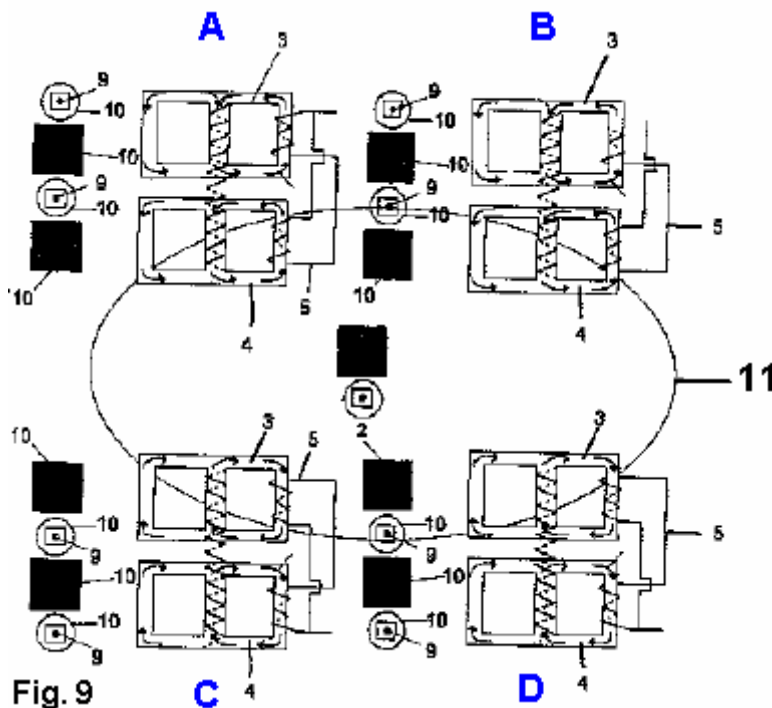

Fig.9 shows an electron-trap circuit diagram with four sets **A, B, C** and **D** of inductor coils **3** and **4**. Induction is produced around core **9** of the three sets of coils **A, B, C** and **D**. The effect of the interaction of the

electromagnetic fields **11** is shown. The induction via core **9**, causes the circulation of electric current in the links **5**, attracting the free electrons through the electromagnetic field of the trap. Then, the electrons join with the current generated by induction on link **5**, circulating between the magnetic poles north-south and south-north.

By way of example, the coils **3** are shown wound on a single phase column type core, but these can also be of any kind or shape. The electron-trap proposed by the present invention can be constructed with another type of electromagnetic field generating device which has at least one electromagnetic coil or magnet or electromagnetic inductor which can be of any kind or shape, or any combination of those, and with any number in each phase of the electron-trap.

The electron capture occurs through an electromagnetic field which is formed with the connection of coils **3** with the electromagnets or inductors **4** through the links **5** between the eight components.

This closure produces the displacement of the electrons in the coil **3** set (**A**) (for simplicity, referred to as coil **3A**), these electrons are attracted by the protons of coil **3D**, and are repelled by the electrons of the electromagnetic field of the coil **3D** itself. These coil **3D** electrons are attracted by the protons of the coil **3B**, and are repelled by the electrons of the electromagnetic field of coil **3B**. These electrons of coil **3B** are attracted by the protons of coil **3C**, and are repelled by the electrons of the electromagnetic field of the coil **3C** itself. Similarly, the **3C** coil electrons are attracted by protons of the **3A** coil, and are repelled by the electrons of the electromagnetic field of the coil **3A** itself. These coil **3A** electrons are attracted by the protons of the **3D** coil, and are repelled by the electrons of the electromagnetic field of the **3D** coil itself. Analogously, the coil **3D** electrons are attracted by the protons of the coil **3B**, and are repelled by the electrons of the electromagnetic field of the coil **3B** itself. These **3B** coil electrons are attracted by the protons of coil **3C**, and are repelled by the electrons of the coil itself induced **3C**, and then the coil **3C** electrons are attracted by protons of coil **3A**, and are repelled by the electrons of the electromagnetic field of the coil **3A** itself. That cycle continues as the sets of coils **A**, **B**, **C** and **D** are being fed by a voltage. These endless attractions and repulsions generate an electric current in the link coil **5**.

In the electron-trap, the voltage is stable. Regardless of the amount of current generated-which can be very high, the voltage will be the same in the electric circuit of the sensor, because the current moves through the attraction and repulsion of the electrons, regardless of voltage.

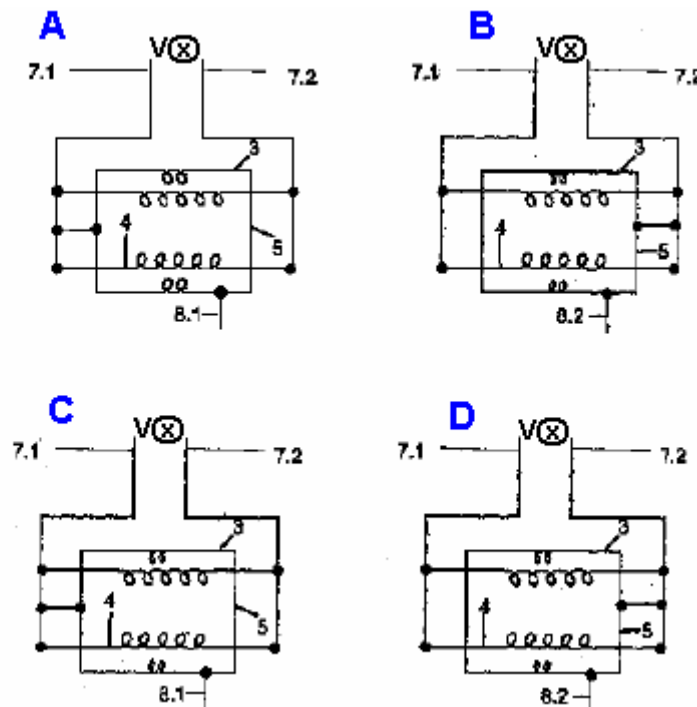

Fig. 10

Fig.10 illustrates a circuit diagram of the electrical connection between the coils **3** and **4** in sets **A**, **B**, **C** and **D**. It can be seen that the sets **A**, **B**, **C** and **D** are enclosed between the coils **3** and their associated inductors or electromagnets **4**. The supply conductors **7.1** and **7.2**, of sets **A**, **B**, **C** and **D** must be interconnected. When feeding power to the coils **3** and **4** the phase should be connected to **7.1** and the neutral to **7.2**.

The sets **A**, **B**, **C** and **D** after being fed with electric current, generate voltage through the attraction and repulsion of the electrons in the linking coil **5**, where there is at least one output load **8.1**, which should be connected joining sets **A** and **C**, and at least one load output **8.2**, which should be connected joining sets **B** and **D**. The output points **8.1** and **8.2** are the respective phases and neutral of power points **7.1** and **7.2**.

In this way, a single-phase electron-trap is created by two pairs of sets of coils/inductors **3** and **4**.

The **3/4** electromagnet coil set can be replaced by a **3/3** coil set, without any disadvantage to the electron-trap.

Sets **A**, **B**, **C** and **D**, are inserted into a hollow metal hemisphere **1** preferably constructed from - but not limited to - aluminium. The hemisphere **1**, whose function is to concentrate and maximise their electromagnetic fields, simulating an electron cloud, has a fixed support **6** connected to attachment tabs **2**, and to which the coils **3** are fixed.

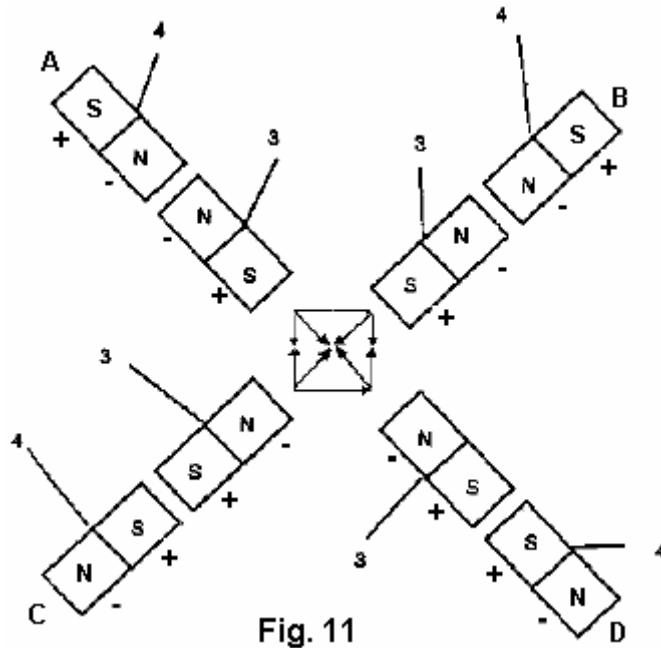

Fig. 11

Fig.11 is a diagram of the electromagnetic north and south poles of the inductor coils **3** and **4** of sets **A**, **B**, **C** and **D** of the electron-trap. The electromagnetic behaviour described for **Fig.9** is again demonstrated by the formation of the magnet assembly to the North Pole and South Pole being attracted and repelled by the lines of force of the magnet from the point "A" to point "D", point "A" to point "B", the point "B" to point "C", point "C" to point "A", and so on, as long as there is an electromagnetic field. The electromagnetic field of the space electron-trap provides that induced current in a direction similar to the variations of the magnetic flux that produced it. So, the magnetic field creates a north pole and a south pole in each of the sets **A**, **B**, **C** and **D**, as shown in **Fig.11**.

By feeding the coils **3** of the electron-trap with a desired voltage a magnetic field is generated in coils **3**, between the four sets **A**, **B**, **C** and **D**, which form a flow of electrons. This flow of electrons augments the electron flow which is circulating in the closed-loop link-coil **5**, thus implementing free electron capture from space. The electromagnetic field of the coil **3A** runs north to south, the electromagnetic field of the coil **3B** runs north to south, the electromagnetic field of the coil **3C** flows from south to north, and the electromagnetic field of the coil **3D** flows from south to north, as shown in **Fig.11**. It should be noted that the sets **A**, **B**, **C** and **D** can be formed by any combination of coil, magnet and electromagnet.

The south to north electromagnetic field induces current flow in the coil **3A**. The north to south electromagnetic field induces current flow in the coil **3B**. The north to south electromagnetic field induces current flow in the coil **3C** and The north to south electromagnetic field induces current flow in the coil **3D**. The induced current flow can have any power and it can be single-phase, two-phase or three-phase current.

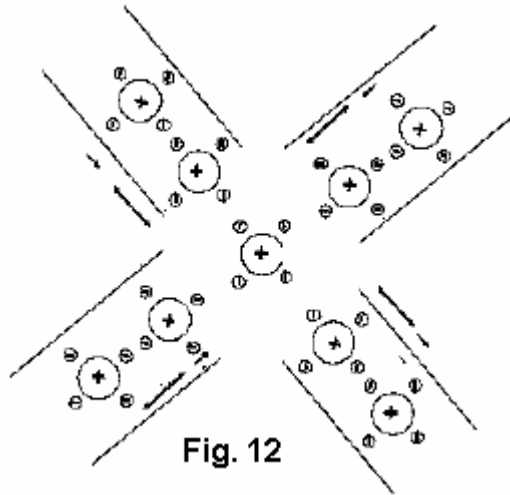

Fig. 12

Fig.12 shows the electrons being attracted and repelled by the induction coils 3 and 4. Being repelled and attracted by electromagnetic induction, the electric current flows without resistance.

The electron-trap produces electromagnetic waves which can be used for various purposes, including signal transmission at any frequency and for any purpose. The capture is caused by these electromagnetic waves. The same physical effect can be achieved by the combination of the capture devices of other technologies, including electromechanical, electric, electronic, electromagnetic, or through the combination of a magnet or any other magnetised materials.

The space free electron-trap of the present invention is a renewable source of electrical power production and a new way of generating energy through the capture effect, generating flows of electrons, generating ordered movement of electrons - electric current - as shown in **Figures 9, 11, and 12**. Electrons can move without any voltage difference in the continuous loop 5. Alternatively, the loop may be biased with any chosen voltage.

The relevant Barbosa and Leal patents in Portuguese can be downloaded here:

<http://www.free-energy-info.tuks.nl/Barbosa1.pdf>

<http://www.free-energy-info.tuks.nl/Barbosa2.pdf>

<http://www.free-energy-info.tuks.nl/Barbosa3.pdf>

The Solid-State Magnetostrictive System of Annis and Eberly.

Theodore Annis & Patrick Eberly have produced a variation on this multiple-magnetic-path method which is shown in their US Patent Application 20090096219. They have opted to use a motionless reluctance switch which is a solid-state device which can block magnetic flow when energised. They have arranged one of their devices like this:

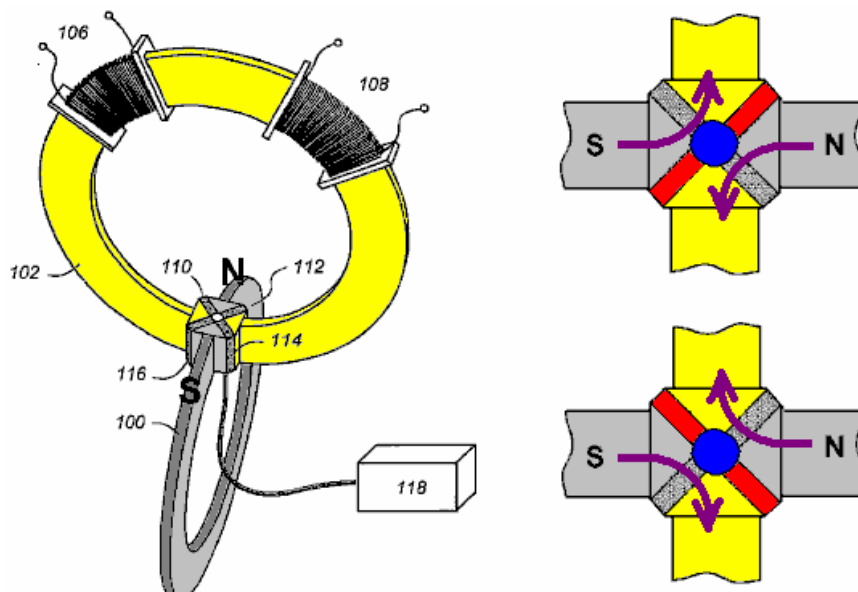

The ring shown in grey is a magnet which connects to the ring shown in yellow through two diagonal 'reluctance' (magnetic flow) switches. The yellow ring can carry magnetic flux and the control box marked **118** switches the diagonal strips on and off in turn, causing the magnetic flux to reverse it's direction through the yellow ring. The coils wound on the yellow ring pick up this reversing magnetic flux and pass it out as an electric current. While only one pair of rings are shown here, the design allows for as many rings as are needed to be connected together as shown here:

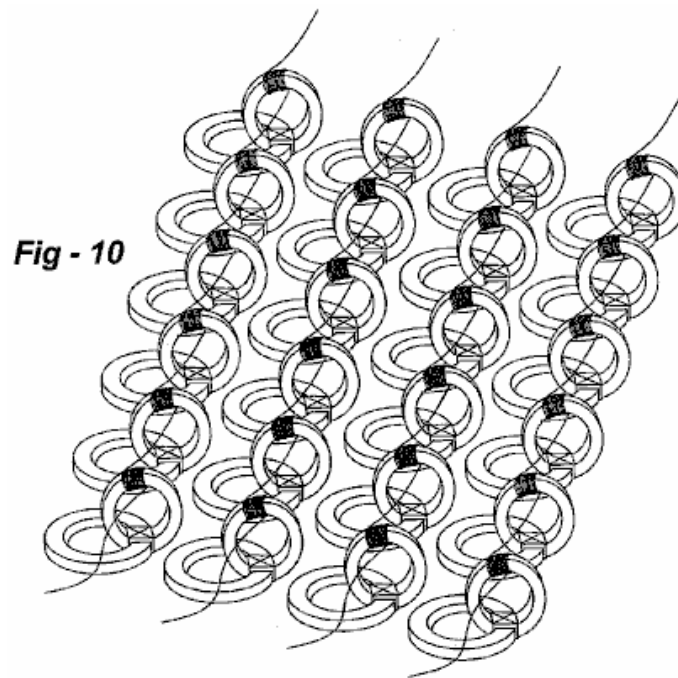

The patent says: "The currently preferred motionless reluctance switch is described by Toshiyuki Ueno & Toshiro Higuchi, in their paper entitled „Investigation of the Dynamic Properties of a Magnetic Flux Control Device composed of Laminations of Magnetostrictive Piezoelectric Materials” – University of Tokyo 2004. As shown in Fig.4, this switch is made of a laminate of a Giant Magnetostrictive Material **42**, a TbDyFe alloy, bonded on both sides to a Piezoelectric material **44**, **46** to which electricity is applied. The application of electricity causes the reluctance of the piezoelectric material to increase.

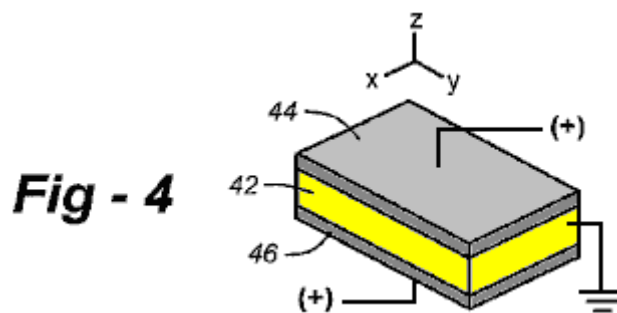

The full patent is included in the Appendix.

The Motionless Generator of Richard Willis.

On 28th May 2009 a European Patent application was filed by Richard Willis, entitled "Electrical Generator". During a TV interview, Richard stated that his design has COP=3,600. Available commercially from his Canadian company and sold under the name "Magnacoster", early in 2010 his advertised pricing is US \$4,200 for a unit which has four separate 100 amp 12V outputs, giving a combined maximum output power of 4.8 kilowatts. A larger unit is priced at US \$6,000 with four separate 24V outlets providing a 9 kilowatt combined output. The house-powering unit which is supplied with a 12 kilowatt inverter to provide mains AC power and which gets connected direct to the circuit-breaker box of the house, is priced at US \$15,000. One particularly interesting statement made by Richard is that the output power



is at a higher frequency than the input power. He suggests that the electrical signal bounces around inside the device, multiplying the power as it goes and giving the output higher voltage and higher current than the input. The design of the device is most interesting as it is very simple. It is shown in his patent application WO 2009065219, a somewhat reworded copy of which is included in the Appendix to this eBook. Richard's web site is <http://www.vorktex.ca/page/235610203>. However, while Richard's designs do indeed work, he appears to be experiencing problems with the output wiring melting due to the very high current, and more importantly, the generation of high levels of unwanted electromagnetic radiation. These problems appear to have prevented him from supplying any commercial units at this time.

The circuit is based on a pulsed coil and two magnets and it has a number of unusual features. The power supply is unusual:

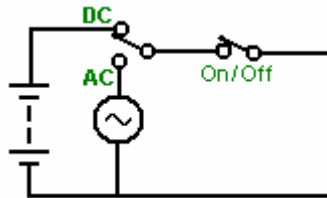

Richard arranges it like this so that either DC or AC can be used as the input power and so he follows that arrangement with a diode bridge, followed by two more diodes as shown here:

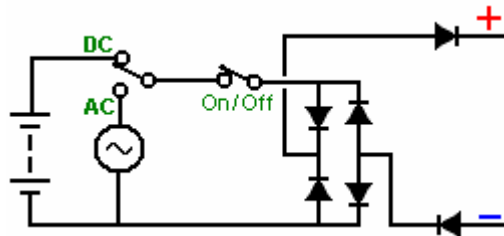

This is an interesting arrangement when the input is DC as it would be a more usual arrangement to have the diode bridge only in the AC input section and not included for the DC input where it just drops the input voltage and wastes electrical power unnecessarily. Still, that is the way it is shown in the patent, so that is the way it is shown here.

The input power supply is fed to an electromagnet but is converted into a pulsed supply by the use of an interrupter switch which may be mechanical or electronic:

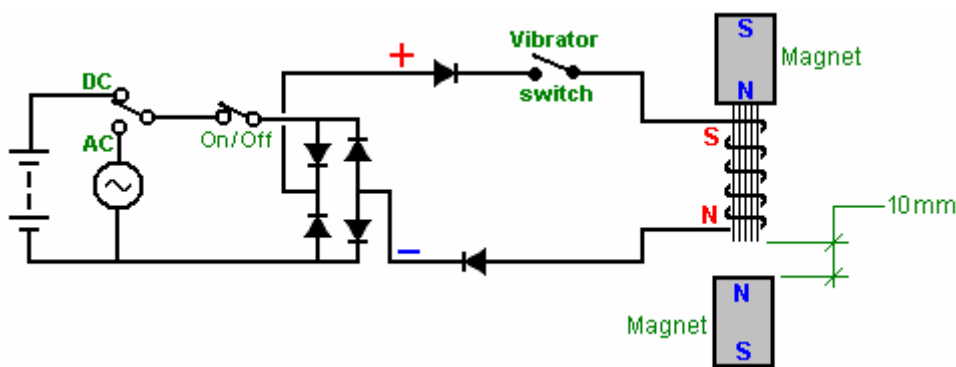

As can be seen, the arrangement is particularly simple although it is an unusual configuration with the electromagnet core touching one of the permanent magnets and not the other. The magnet and electromagnet poles are important, with the permanent magnet North poles pointing towards the electromagnet and when the electromagnet is powered up, it's South pole is towards the North pole of the permanent magnet which it is touching. This means that when the electromagnet is powered up, it's magnetic field strengthens the magnetic field of that magnet.

There is a one-centimetre gap at the other end of the electromagnet and it's North pole opposes the North pole of the second permanent magnet. With this arrangement, each electromagnet pulse has a major magnetic effect on the area between the two permanent magnets. In the diagram shown above, just a few turns of wire are shown on the electromagnet core. This is just for clarity and it does not mean that only a few turns should be used. The strength of the magnets, the electromagnet wire thickness and number of turns are related to each other and experimentation will be needed to determine the best combination.

The energy take-off from this device is shown here:

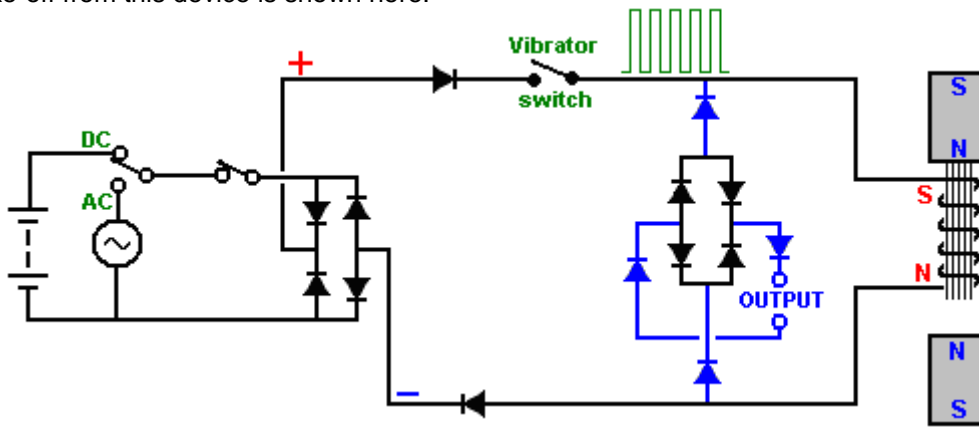

Richard states that the input power can be anywhere from under one volt to one million volts while the input current can be anything from under one amp to one million amps, so he clearly envisages a major range of constructions and components. The core material for the electromagnet is specified as ferrite, mumetal, permalloy, cobalt or any non-permeable metal material. It seems likely that iron filings embedded in epoxy resin is likely to be a suitable material as it can respond very rapidly to sharp pulses and it seems clear that in common with almost every other similar free-energy device, the rapidity of rise and fall of the power pulse is of major importance. Having said that, Richard states that the frequency of pulses in the output section is greater than the frequency of pulses applied to the input section. From this it seems likely that the device should be tuned so that the input pulses should be at a lower harmonic of the resonant frequency of the device. It is worth reading Richard's full description which is near the end of the Appendix.

A second version of the circuit looks like a modification of the John Bedini pulsed rotor battery charging circuit with a rotor substituting for the second permanent magnet:

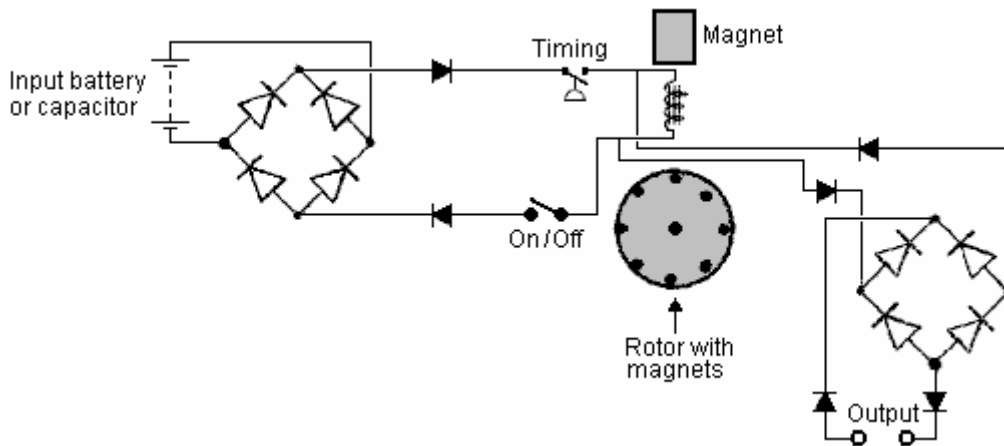

This enhances the operation of the Bedini device by providing an initial magnetic field in the coil.

The Generator Proposal of "Silverhealthu".

One of the EVGRAY yahoo forum members whose ID is 'silverhealthu' has described a simple device which appears to be not unlike the Richard Willis generator above.

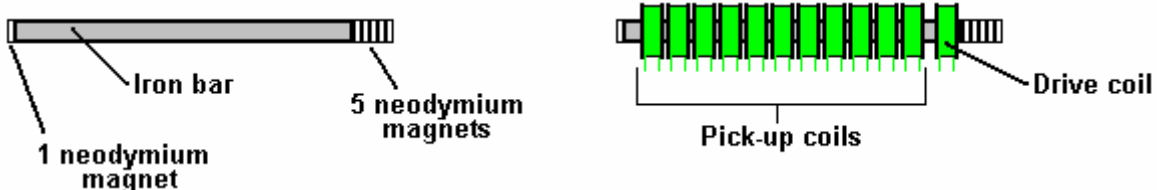

The device consists of an iron bar one inch (25 mm) in diameter and one foot (300 mm) long. At one end, there is a stack of five neodymium magnets and at the opposite end, a single neodymium magnet. At the end with the five

magnets, there is a coil of wire which is strongly pulsed by a drive circuit. Down the length of the bar, a series of pick-up coils are positioned. Each of these coils picks up the same level of power that is fed to the pulsing coil and the combined output is said to exceed the input power.

Stephan Leben's Circuits.

There is an interesting video posted on YouTube at http://www.youtube.com/watch?v=9zh_C3yvJH0 where Stephan W. Leben whose ID is "TheGuru2You" posts some really interesting information. He starts with a circuit produced by Alexander Meissner in 1913 and shown here:

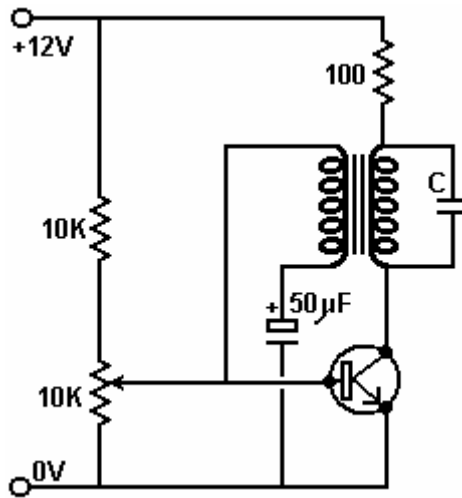

Stephan states that he has built this circuit and can confirm that it is a self-resonating powering circuit. Once a twelve volt supply is connected to the input terminals, the transistor switches on powering the transformer which feeds repeating pulses to the base of the transistor, sustaining the oscillations. The rate of oscillation is governed by the capacitor marked "C" in the circuit diagram above and the coil across which it is connected.

Stephan suggests combining Alexander Meissner's circuit with Charles Flynn's magnetic amplification circuit. Here the transformer is switched to become the Charles Flynn oscillator winding plus a second winding placed alongside for magnetic coupling as shown here:

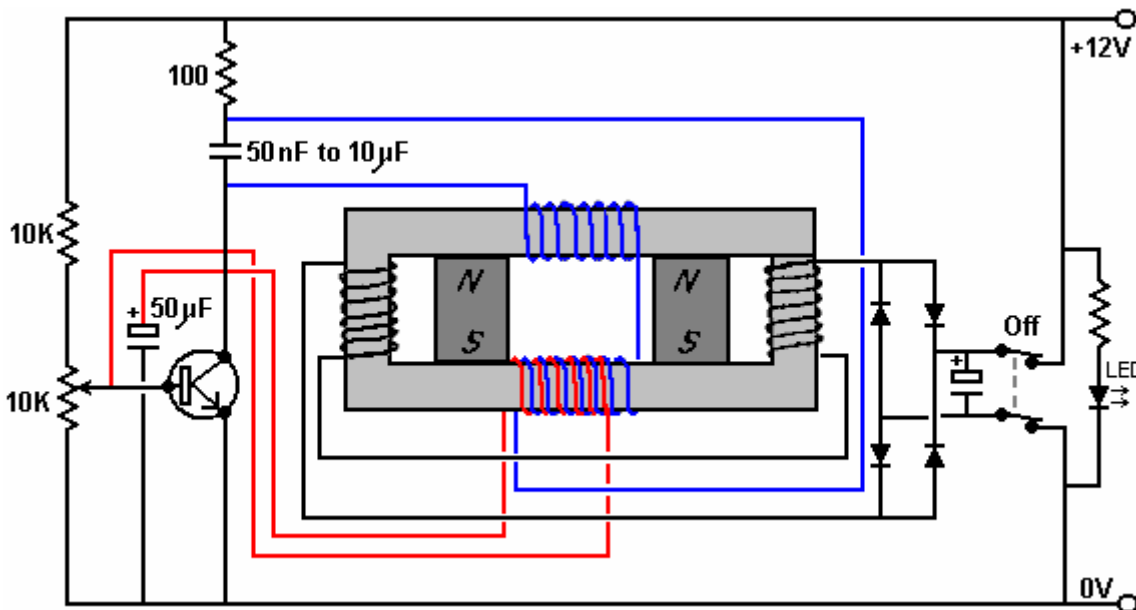

The transistor stage is self-oscillating as before, the transformer now being made up of the red and blue coil windings. This oscillation also oscillates the Flynn magnetic frame, producing an electrical output via the black coils at each end of the magnetic frame. This is, of course, an oscillating, or AC output, so the four diodes produce a full-wave rectified (pulsating) DC current which is smoothed by the capacitor connected to the diodes.

This circuit would be started by touching a 12 volt source very briefly to the output terminals on the right. An alternative would be to wave a permanent magnet close to the red and blue coils as that generates a voltage in the coils, quite sufficient to start the system oscillating and so, becoming self-sustaining. Stephan suggests using the piezo crystal from a lighter and connecting it to an extra coil to produce the necessary voltage spike when the coil is held close to the blue coil and the lighter mechanism clicked.

A surprising problem would be how to switch the device off since it runs itself. To manage this, Stephan suggests a two-pole On/Off switch to disconnect the output and prevent it supplying the input section of the circuit. To show whether or not the circuit is running, a Light-Emitting Diode ("LED") is connected across the output and the current flowing through it limited by a resistor of about 820 ohms.

Anyone wanting to try replicating this device will need to experiment with the number of turns in each coil and the wire diameter needed to carry the desired current. Stephan states that you need to have at least twice the weight of copper in the (black) output coils as there is in the (blue) input coils in order to allow the device produce excess power. The first page of the Appendix shows the current carrying capacity for each of the standard wire diameters commonly offered for sale. As this is a fairly recently released circuit, I am not aware of any replications of it at this time.

Floyd Sweet's "VTA" Generator.

Another device in the same category of permanent magnets with energised coils round it (and very limited practical information available) was produced by Floyd Sweet. The device was dubbed "Vacuum Triode Amplifier" or "VTA" by Tom Bearden.

The device was capable of producing more than 1 kW of output power at 120 Volts, 60 Hz and can be wired to be self-powered. The output is energy which resembles electricity in that it powers motors, lamps, etc. but as the power increases through any load there is a temperature drop instead of the expected temperature rise.

When it became known that he had produced the device he became the target of serious threats, some of which were delivered face-to-face in broad daylight. It is quite possible that the concern was due to the device tapping zero-point energy, which when done at high currents opens a whole new can of worms. One of the observed characteristics of the device was that when the current was increased, the measured weight of the apparatus reduced by about a pound. While this is hardly new, it suggests that space/time was being warped. The German scientists at the end of WWII had been experimenting with this (and killing off the unfortunate people who were used to test the system) - if you have considerable perseverance, you can read up on this in Nick Cook's inexpensive book "The Hunt for Zero-Point" ISBN 0099414988.

Floyd found that the weight of his device reduced in proportion to the amount of energy being produced. But he found that if the load was increased enough, a point was suddenly reached where a loud sound like a whirlwind was produced, although there was no movement of the air. The sound was heard by his wife Rose who was in another room of their apartment and by others outside the apartment. Floyd did not increase the load further (which is just as well as he would probably have received a fatal dose of radiation if he had) and did not repeat the test. In my opinion, this is a dangerous device and I personally, would not recommend anyone attempting to build one. It should be noted that a highly lethal 20,000 volts is used to 'condition' the magnets and the principles of operation are not understood at this time. Also, there is insufficient information to hand to provide realistic advice on practical construction details.

On one occasion, Floyd accidentally short-circuited the output wires. There was a bright flash and the wires became covered with frost. It was noted that when the output load was over 1 kW, the magnets and coils powering the device became colder, reaching a temperature of 20 degrees Fahrenheit below room temperature. On one occasion, Floyd received a shock from the apparatus with the current flowing between the thumb and the small finger of one hand. The result was an injury akin to frostbite, causing him considerable pain for at least two weeks.

Observed characteristics of the device include:

1. The output voltage does not change when the output power is increased from 100W to 1 kW.
2. The device needs a continuous load of at least 25W.
3. The output falls in the early hours of the morning but recovers later on without any intervention.
4. A local earthquake can stop the device operating.
5. The device can be started in self-powered mode by briefly applying 9 Volts to the drive coils.
6. The device can be stopped by momentary interruption of the power to the power coils.
7. Conventional instruments operate normally up to an output of 1 kW but stop working above that output level, with their readings showing zero or some other spurious reading.

Information is limited, but it appears that Floyd's device was comprised of one or two large ferrite permanent magnets (grade 8, size 150 mm x 100 mm x 25 mm) with coils wound in three planes mutually at right angles to each other (i.e. in the x, y and z axes). The magnetisation of the ferrite magnets is modified by suddenly applying 20,000 Volts from a bank of capacitors (510 Joules) or more to plates on each side of it while simultaneously driving a 1 Amp 60 Hz (or 50 Hz) alternating current through the energising coil. The alternating current should be at the frequency required for the output. The voltage pulse to the plates should be applied at the instant when the 'A' coil voltage reaches a peak. This needs to be initiated electronically.

It is said that the powering of the plates causes the magnetic material to resonate for a period of about fifteen minutes, and that the applied voltage in the energising coil modifies the positioning of the newly formed poles of the magnet so that it will in future, resonate at that frequency and voltage. It is important that the voltage applied to the energising coil in this 'conditioning' process be a perfect sinewave. Shock, or outside influence can destroy the 'conditioning' but it can be reinstated by repeating the conditioning process. It should be noted that the conditioning process may not be successful at the first attempt but repeating the process on the same magnet is usually successful. Once conditioning is completed, the capacitors are no longer needed. The device then only needs a few milliwatts of 60 Hz applied to the input coil to give up to 1.5 kW at 60 Hz at the output coil. The output coil can then supply the input coil indefinitely.

The conditioning process modifies the magnetisation of the ferrite slab. Before the process the North pole is on one face of the magnet and the South pole on the opposite face. After conditioning, the South pole does not stop at the mid point but extends to the outer edges of the North pole face, extending inwards from the edge by about 6 mm. Also, there is a magnetic 'bubble' created in the middle of the North pole face and the position of this 'bubble' moves when another magnet is brought near it.

The conditioned slab has three coil windings:

1. The 'A' coil is wound first around the outer perimeter, each turn being $150 + 100 + 150 + 100 = 500$ mm long (plus a small amount caused by the thickness of the coil former material). It has about 600 turns of 28 AWG (0.3 mm) wire.
2. The 'B' coil is wound across the 100 mm faces, so one turn is about $100 + 25 + 100 + 25 = 250$ mm (plus a small amount for the former thickness and clearing coil 'A'). It has between 200 and 500 turns of 20 AWG (1 mm) wire.
3. The 'C' coil is wound along the 150 mm face, so one turn is $150 + 25 + 150 + 25 = 350$ mm (plus the former thickness, plus clearance for coil 'A' and coil 'B'). It has between 200 and 500 turns of 20 AWG (1 mm) wire and should match the resistance of coil 'B' as closely as possible.

Coil 'A' is the input coil. Coil 'B' is the output coil. Coil 'C' is used for the conditioning and for the production of gravitational effects.

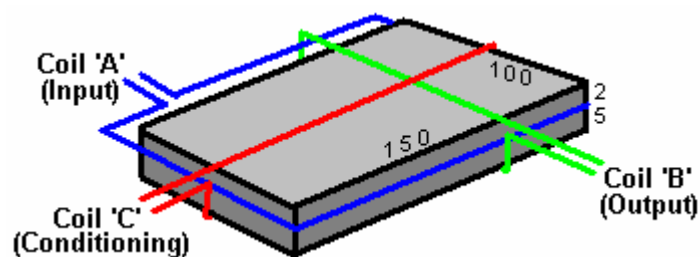

Videos of the operation of the original prototype are available for sale on DVD from Tom Beardon's website: <http://www.cheniere.org/sales/sweetvideos.htm> as he recorded both of these videos. A paper by Michael Watson gives much practical information. For example, he states that an experimental set up which he made, had the 'A' coil with a resistance of 70 ohms and an inductance of 63 mH, the 'B' coil, wound with 23 AWG wire with a resistance of 4.95 ohms and an inductance of 1.735 mH, and the 'C' coil, also wound with 23 AWG wire, with a resistance of 5.05 ohms and an inductance of 1.78 mH.

Recently, some additional information on Floyd Sweet's device, has been released publicly by an associate of Floyd's who goes just by his first name of "Maurice" and who, having reached the age of seventy has decided that it is time to release this additional information. That information can be found in the Appendix. While I am not aware of anybody managing to replicate this device of Floyd Sweet in exactly the way shown here, there is now a

video at <http://www.youtube.com/watch?v=UVhGQaESKEI&feature=g-u-u> where two different experimenters describe their advances, successes and experiences with this arrangement and with closely related configurations.

The Optical Generator of Pavel Imris.

Pavel was awarded a US patent in the 1970's. The patent is most interesting in that it describes a device which can have an output power which is more than nine times greater than the input power. He achieves this with a device which has two pointed electrodes enclosed in a quartz glass envelope which contains xenon gas under pressure (the higher the pressure, the greater the gain of the device) and a dielectric material.

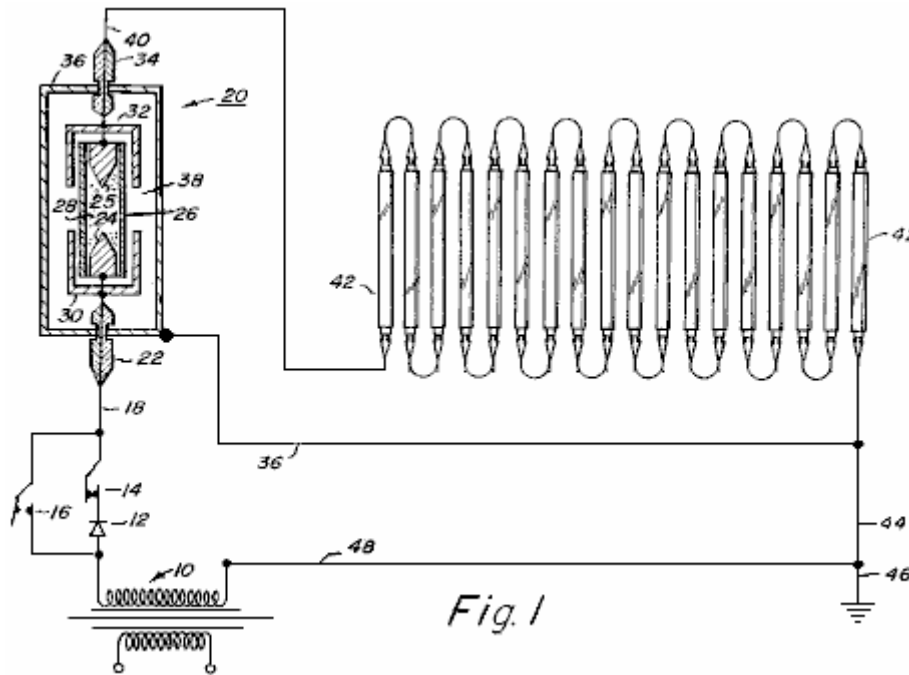

Here, the power supply to one or more standard fluorescent lamps is passed through the device. This produces a power gain which can be spectacular when the gas pressure in the area marked '24' and '25' in the above diagram is high. The patent is included in this set of documents and it contains the following table of experimental measurements:

Table 1 shows the data to be obtained relating to the optical electrostatic generator. **Table 2** shows the lamp performance and efficiency for each of the tests shown in **Table 1**. The following is a description of the data in each of the columns of **Tables 1 and 2**.

Column	Description
B	Gas used in discharge tube
C	Gas pressure in tube (in torrs)
D	Field strength across the tube (measured in volts per cm. of length between the electrodes)
E	Current density (measured in microamps per sq. mm. of tube cross-sectional area)
F	Current (measured in amps)
G	Power across the tube (calculated in watts per cm. of length between the electrodes)
H	Voltage per lamp (measured in volts)
K	Current (measured in amps)
L	Resistance (calculated in ohms)
M	Input power per lamp (calculated in watts)
N	Light output (measured in lumens)

Table 1

	Optical		Generator	Section		
A	B	C	D	E	F	G
Test No.	Type of discharge lamp	Pressure of Xenon	Field strength across lamp	Current density	Current	Power str. across lamp
		(Torr)	(V/cm)	(A/sq.mm)	(A)	(W/cm.)
1	Mo elec	-	-	-	-	-
2	Xe	0.01	11.8	353	0.1818	2.14
3	Xe	0.10	19.6	353	0.1818	3.57
4	Xe	1.00	31.4	353	0.1818	5.72
5	Xe	10.00	47.2	353	0.1818	8.58
6	Xe	20.00	55.1	353	0.1818	10.02
7	Xe	30.00	62.9	353	0.1818	11.45
8	Xe	40.00	66.9	353	0.1818	12.16
9	Xe	60.00	70.8	353	0.1818	12.88
10	Xe	80.00	76.7	353	0.1818	13.95
11	Xe	100.00	78.7	353	0.1818	14.31
12	Xe	200.00	90.5	353	0.1818	16.46
13	Xe	300.00	100.4	353	0.1818	18.25
14	Xe	400.00	106.3	353	0.1818	19.32
15	Xe	500.00	110.2	353	0.1818	20.04
16	Xe	600.00	118.1	353	0.1818	21.47
17	Xe	700.00	120.0	353	0.1818	21.83
18	Xe	800.00	122.8	353	0.1818	22.33
19	Xe	900.00	125.9	353	0.1818	22.90
20	Xe	1,000.00	127.9	353	0.1818	23.26
21	Xe	2,000.00	149.6	353	0.1818	27.19
22	Xe	3,000.00	161.4	353	0.1818	29.35
23	Xe	4,000.00	173.2	353	0.1818	31.49
24	Xe	5,000.00	179.1	353	0.1818	32.56

Table 2

	Fluorescent		Lamp	Section	
A	H	K	L	M	N
Test No.	Voltage	Current	Resistance	Input Energy	Light Output
	(Volts)	(Amps)	(Ohms)	(Watts)	(Lumen)
1	220	0.1818	1,210	40.00	3,200
2	218	0.1818	1,199	39.63	3,200
3	215	0.1818	1,182	39.08	3,200
4	210	0.1818	1,155	38.17	3,200
5	200	0.1818	1,100	36.36	3,200
6	195	0.1818	1,072	35.45	3,200
7	190	0.1818	1,045	34.54	3,200
8	182	0.1818	1,001	33.08	3,200
9	175	0.1818	962	31.81	3,200
10	162	0.1818	891	29.45	3,200
11	155	0.1818	852	28.17	3,200
12	130	0.1818	715	23.63	3,200
13	112	0.1818	616	20.36	3,200
14	100	0.1818	550	18.18	3,200
15	85	0.1818	467	15.45	3,200
16	75	0.1818	412	13.63	3,200
17	67	0.1818	368	12.18	3,200
18	60	0.1818	330	10.90	3,200
19	53	0.1818	291	9.63	3,200
20	50	0.1818	275	9.09	3,200
21	23	0.1818	126	4.18	3,200
22	13	0.1818	71	2.35	3,200
23	8	0.1818	44	1.45	3,200
24	5	0.1818	27	0.90	3,200

The results from Test No. 24 where the gas pressure is a very high 5,000 Torr, show that the input power for each 40-watt standard fluorescent tubes is 0.9 watts for full lamp output. In other words, each lamp is working to its full specification on less than one fortieth of its rated input power. However, the power taken by the device in that test was 333.4 watts which with the 90 watts needed to run the 100 lamps, gives a total input electrical power of 423.4 watts instead of the 4,000 watts which would have been needed without the device. That is an output power of more than nine times the input power.

From the point of view of any individual lamp, without using this device, it requires 40 watts of electrical input power to give 8.8 watts of light output which is an efficiency of about 22% (the rest of the input power being converted to heat). In test 24, the input power per lamp is 0.9 watts for the 8.8 watts of light produced, which is a lamp efficiency of more than 900%. The lamp used to need 40 watts of input power to perform correctly. With this device in the circuit, each lamp only needs 0.9 watts of input power which is only 2.25% of the original power. Quite an impressive performance for so simple a device!

The Michel Meyer and Yves Mace Isotopic Generator.

There is a French patent application number FR 2,680,613 dated 19th August 1991 entitled "Activateur pour Mutation Isotopique" which provides some very interesting information. The system described is a self-contained solid-state energy converter which abstracts large amounts of energy from an ordinary iron bar. This is also shown in Michel's Czechoslovakia Patent No.284,333

The inventors describes the technique as an "isotopic mutation effect" as it converts ordinary iron (isotope 56) to isotope 54 iron, releasing large amounts of electrical energy in the process. This excess energy can, they say, be used to drive inverters, motors or generators.

The description of the mechanism which is being used by the device is: "the present invention uses a physical phenomenon to which we draw attention and which we will call 'Isotopic Change'. The physical principle applies to isotope 56 iron which contains 26 protons, 26 electrons and 30 neutrons, giving a total mass of 56.52 Mev, although its actual mass is 55.80 Mev. The difference between the total mass and the actual mass is therefore 0.72 Mev this which corresponds to an energy of cohesion per nucleon of 0.012857 Mev.

So, If one introduces an additional 105 ev of energy to the iron core isotope 56, that core isotope will have a cohesion energy level of 0.012962 Mev per nucleon corresponding to iron isotope 54. The instability created by this contribution of energy will transfer the isotope 56 iron to isotope 54 causing a release of 2 neutrons.

This process generates an excess energy of 20,000 ev since the iron isotope 54 is only 0.70 Mev while isotope 56 has 0.72 Mev. To bring about this iron isotope 56 conversion, we use the principle of Nuclear Magnetic Resonance.”

The practical method for doing this is by using three coils of wire and a magnetic-path-closing support frame of iron as shown in this diagram:

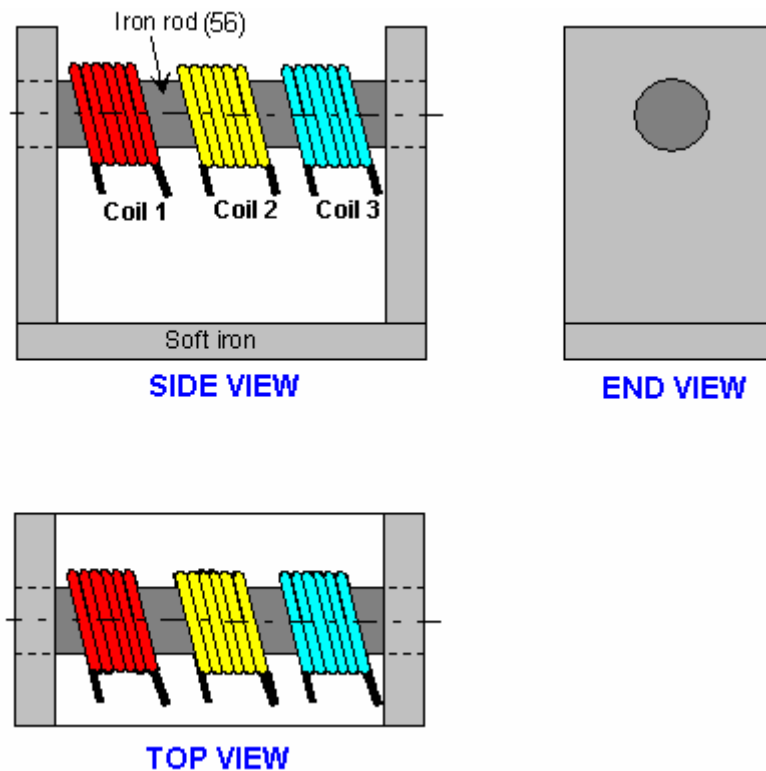

In this arrangement,

Coil 1: Produces 0.5 Tesla when fed with DC, converting the iron bar into an electromagnet

Coil 2: Produces 10 milli-Tesla when fed with a 21 MHz AC sinewave signal

Coil 3: Is the output coil, providing 110, 220 or 380 volts AC at about 400 Hz depending on the number of turns in the coil

This simple and cheap system has the potential for producing substantial energy output for a very long time. The inventors claim that this device can be wired to be self-powered, while still powering external devices. Coil 1 turns the iron rod into an electromagnet with it's flux channelled in a loop by the iron yoke. Coil 2 then oscillates that magnetic field in resonance with the isotope 56 iron atoms in the rod, and this produces the isotope conversion and release of excess energy. Coil 3 is wound to produce a convenient output voltage.

The Colman / Seddon-Gilliespie Generator.

This device, patented by Harold Colman and Ronald Seddon-Gillespie on 5th December 1956, is quite remarkable. It is a tiny lightweight device which can produce electricity using a self-powered electromagnet and chemical salts. The working life of the device before needing refurbishment is estimated at some seventy years with an output of about one kilowatt.

The operation is controlled by a transmitter which bombards the chemical sample with 300 MHz radio waves. This produces radioactive emissions from the chemical mixture for a period of one hour maximum, so the transmitter needs to be run for fifteen to thirty seconds once every hour. The chemical mixture is shielded by a lead screen to prevent harmful radiation reaching the user. The patent, GB 763,062 is included in the Appendix.

This generator unit includes a magnet, a tube containing a chemical mixture of elements whose nuclei becomes unstable as a result of bombardment by short waves so that the elements become radio-active and release electrical energy, the mixture being mounted between, and in contact with, a pair of different metals such as copper and zinc, and a capacitor mounted between those metals.

The mixture is preferably composed of the elements Cadmium, Phosphorus and Cobalt having Atomic Weights of 112, 31 and 59 respectively. The mixture, which may be of powdered form, is mounted in a tube of non-conducting, high heat resistivity material and is compressed between granulated zinc at one end of the tube and granulated copper at the other end, the ends of the tube being closed by brass caps and the tube being carried in a suitable cradle so that it is located between the poles of the magnet. The magnet is preferably an electro-magnet and is energised by the current produced by the unit. The transmitter unit which is used for activating the generator unit may be of any conventional type operating on ultra-shortwave and is preferably crystal controlled at the desired frequency.

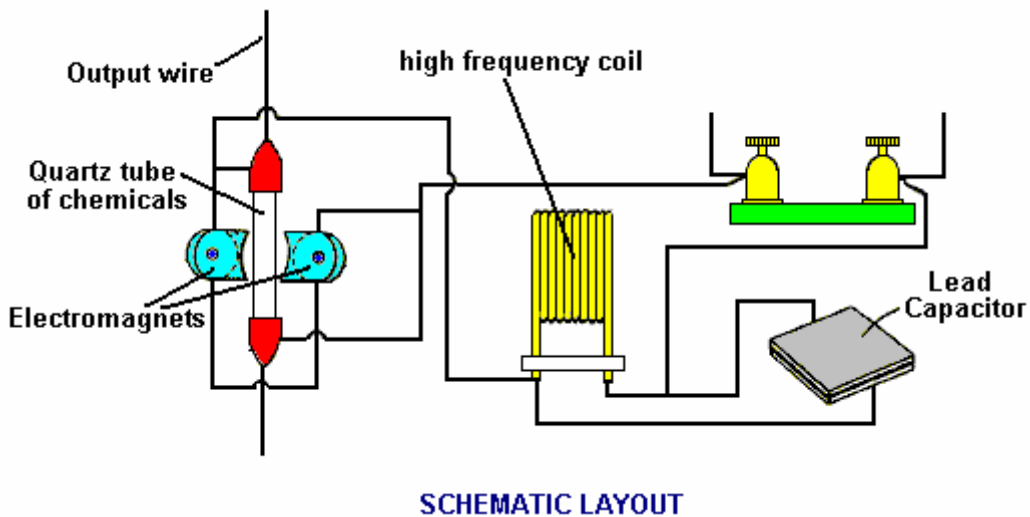
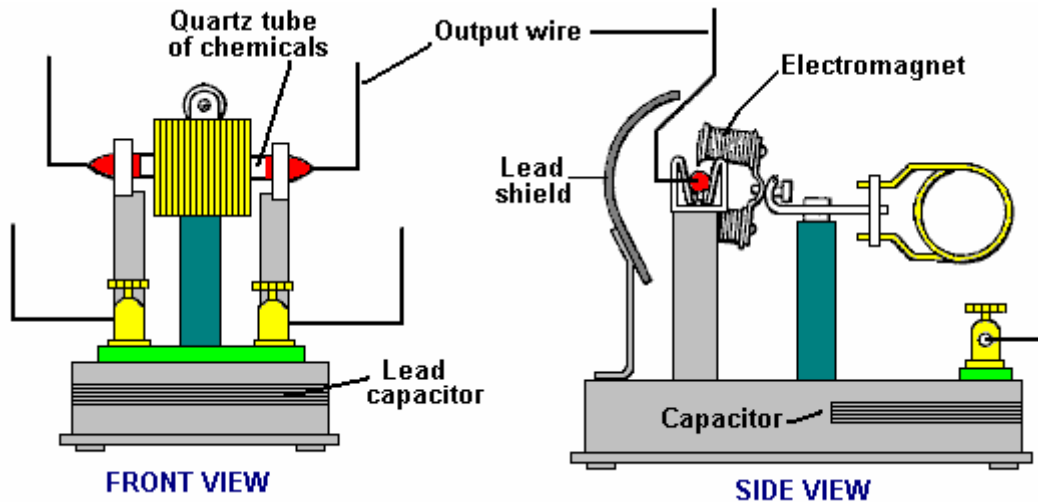

The transmitter unit is of any suitable conventional type for producing ultra shortwaves and may be crystal controlled to ensure that it operates at the desired frequency with the necessity of tuning. The quartz tube containing the chemical mixture, works best if made up of a number of small cells in series. In other words, considering the cartridge from one end to the other, at one end and in contact with the brass cap, there would be a layer of powdered copper, then a layer of the chemical mixture, then a layer of powdered zinc, a layer of powdered copper, etc. with a layer of powdered zinc in contact with the brass cap at the other end of the cartridge. With a cartridge some forty five millimetres long and five millimetres diameter, some fourteen cells may be included.

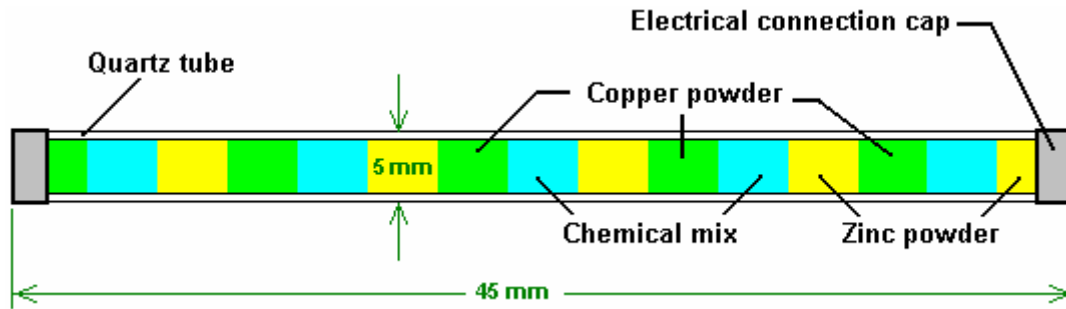

The Devices of Don Smith.

One free-energy developer who had most impressive claims for his devices is the late Don Smith who produced many spectacular devices, generally with major power output. Don says that his understanding comes from the work of Nikola Tesla as recorded in Thomas C. Martin's book "The Inventions, Researches, and Writings of Nikola Tesla" ISBN 0-7873-0582-0 available from <http://www.healthresearchbooks.com> and various other book companies. This book can be downloaded from <http://www.free-energy-info.tuks.nl/> as a pdf file, but a paper copy is much better quality and easier to work from.

Many experimenters have spent considerable time and effort in attempts to replicate the work which Don reports and while COP>1 has definitely been achieved, high power has not yet been reached. If you want more detail then it can be found here: <http://www.free-energy-info.tuks.nl/DonSmith.pdf> as a free download.

Tesla Coils Back-to-Back

I have been told of one man who used his common sense and produced an impressive result. He used a Tesla Coil as the driving force, and then used a second Tesla Coil back-to-back with the first one, to step the high voltage back down again. Doing that, he was able to light a series of powerful light bulbs from the "L1" output coils. He also confirmed that doubling the voltage, quadrupled the power output, verifying what Don said. He also found that adding additional coils with bulbs to the output Tesla Coil, did not increase the input power at all, did not cause any of the existing light bulbs to shine any less brightly, and yet lit the additional bulbs. That would appear to be confirmation of Don's statement that any number of magnetic copies of the original oscillating magnetic field of the first Tesla Coil, can provide a full-power electrical output without requiring any additional input power. I'm no expert, but my understanding of the arrangement is:

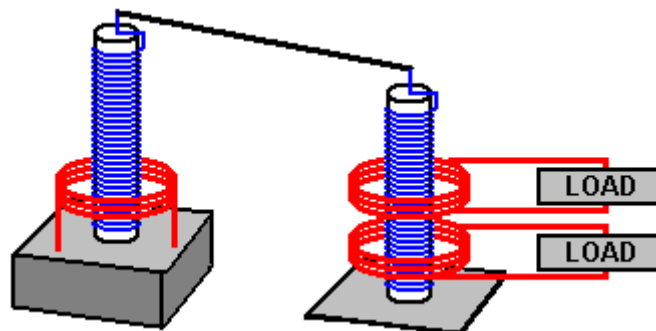

As the large diameter coil is exactly one quarter the length of the smaller diameter coil, there is an automatic resonance of both when the applied frequency is just right. As the first narrow coil is identical to the second narrow coil, they are also automatically resonant together. Again, as the large coils which feed the loads are exactly one quarter the wire length of the narrow coils, they also resonate at the common frequency and at that frequency, the input power is at its minimum while the output power is at its maximum. The spike at the top of each of the narrow coils is connected with a wire to channel the generated power from the first Tesla Coil to the second one.

This arrangement may seem too simple to be effective, but with Tesla technology "too simple" just does not apply. This can be seen clearly from the work of **Nikanor "Nick" Giannopoulos**. Before he ever learned anything about electronics, Nick read and understood Nikola Tesla's "Colorado Spring Notes" (<http://www.free-energy-info.tuks.nl/TeslaCSN.pdf> 60Mb) and this helped with his present level of understanding. Interestingly, and

perhaps not surprisingly, Nick had difficulty with conventional electronics after becoming familiar with Tesla's technology.

Nick used a square wave signal generator adjustable from 50 kHz downwards and with a fully adjustable Mark/Space ratio. This was used to drive an oil-filled car ignition coil, which, as he points out is not a Tesla Coil in spite of the frequently held view that it is. Ignition coils only operate at low frequency due to the limitations of their core material. However, John Stone points out that certain coil designs, such as those for the Fiat 'Punto' car, are built in such a way that replacing the core with ferrite should be possible, and that would allow high frequency operation.

Anyway, Nick uses a standard car ignition coil at lower frequency and uses it to feed a spark gap like this which is constructed from two chipboard screws:



His circuit is:

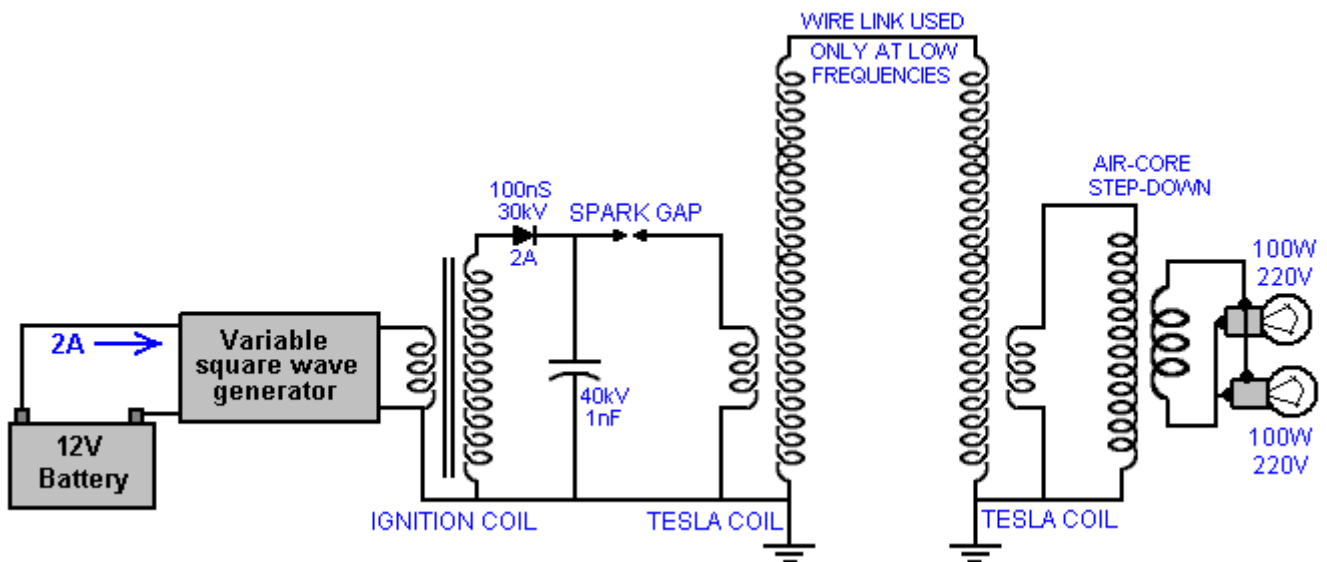

Nick has had very impressive results from his circuit, although it is still very much a work in progress with more development and testing still to be done. The 24 watt input of 12V at 2A is producing two very brightly lit 220V light bulbs. This does not tell us very much about the actual output power as bulbs are notorious for lighting brightly at low power levels, especially if the frequency is high. But, a very important point is the quality of the light which is an unusual, blue-white colour, quite unlike the colour produced when connected to the 220V mains supply. This is generally a sign of the power being 'cold' electricity. While he has not yet had the opportunity to test it, Nick believes that the circuit as it stands now is quite capable of powering much higher loads, and considering the colour of the light, I would be inclined to agree with him, although anything like that has to be tested and proven before any solid conclusions can be drawn from what is already known about the performance. The circuit performance is much improved if two separate physical earth ground connections are made.



Please don't fall into the trap of thinking that because the sparks are occurring at less than 5 kHz, that the Tesla coils also operate at that frequency. If you strike a bell which vibrates at 400 Hz, does that mean that you have to hit it 400 times every second in order to hear it? Actually, no, you don't, and the same thing applies here where the resonant frequency of the Tesla coils is approximately 650 kHz. The primaries are wound on 100 mm diameter PVC pipe sections and 19 turns of 1.02 mm diameter enamelled copper wire is used for them (19 swg or #18 AWG). The secondary coils are wound on 70 mm diameter PVC pipe using 0.41 mm diameter enamelled copper wire (27 swg or #26 AWG) with a total length of four times the primary winding wire length. As you will see later on in this chapter, resonance in a coil involves a standing wave inside the wire. That standing wave is created by the signal bouncing off the end of the wire and being reflected back. At frequencies other than the resonant frequency, this results in a constantly changing set of many different waves travelling in both directions and at different intensities (what could reasonably be described as a total mess). When the resonant frequency is fed to the coil, then all of that mess disappears and just one waveform remains, and at any point along the wire, that waveform appears to be stationary although, of course, it is not actually stationary, just the effect of the peaks always occurring at exactly the same spot and the troughs occurring at exactly the same spot, making successive waves look exactly the same as the previous one.

This feature has one very practical aspect, namely that if you run the same wire away from the coil turns to connect to whatever the next circuit component happens to be, then the wave inside the wire will not bounce back at the end of the coil turns but will continue on to the end of the wire before bouncing back. So, the connecting wire length has to be included when reckoning the wire length in the turns of the coil. On the other hand, if the wire in the coil turns is terminated at the ends of the coil and wire of a very different diameter is used for connecting to the next component in the circuit, then the signal inside the wire will bounce back from the sudden change in wire diameter and so the connecting wire length will not be part of the wire length in the turns of the coil. This is an important feature if you are aiming for an exact 4:1 wire length ratio (and 4:1 wire weight) between the Tesla Coil windings in order to impose an automatic resonance between the two windings.

It should be noted that PVC (especially non-white PVC) has a very restrictive effect on high frequency coils. At low frequencies, PVC is ok, but it drags down the coil performance as the frequency rises, lowering the "Q" (for "Quality") factor of the coil. Using acrylic instead of PVC overcomes this. Alternatively, coating the PVC with a high-voltage insulating material such as shellac or one of the proprietary coating agents, will improve matters considerably. The ideal, of course, is to have no former at all and have the coil standing unaided because of its own strength.

The Screened Transformer of Joseph Boyd.

It is not at all clear if the Boyd power system should be located here or in chapter 7 which deals with aerials. Joseph talks about the way that radio circuits operate and why only very limited power appears to be the limit of

radio receivers. He explains a method of extracting serious levels of power from a transmitting coil and a receiving coil, but the higher power levels require an input oscillator, and so, while an aerial and earth can be used for lower power levels, input power is needed for optimum performance. Here is part of Joseph's patent application:

US Patent Application 2008/0129397

5th June 2008

Joseph Boyd

ELECTROMAGNETIC ELECTRIC GENERATOR

Abstract:

An electrical generator that uses a high frequency oscillator in a tuned circuit, set to resonate with the transmitter coil of a full-length high frequency transformer unit, to generate electromagnetic energy, to transform this energy to electrical energy and to collect this energy.

1. Field of the Invention

The present invention is an electrical generator that uses a high frequency oscillator in a tuned circuit, set to resonate with the transmitter coil of a full-length high frequency transformer unit, to generate electromagnetic energy, to transform this energy to electrical energy and to collect this energy.

2. Description of the Related Art

If an oscillator circuit is properly connected to a tuned antenna so that it resonates, a current will flow between the aerial and the ground, and this produces the high frequency electromagnetic air waves and ground waves of our radios and other electronic equipment.

An oscillator of the same type used in electromagnetic wave transmission equipment is used to generate the electromagnetic energy used in this patent. These electromagnetic transmitters are well developed and are used world wide, and broadcast at frequencies that extend from the longest radio waves to the very short ones. Certain radios send their signals great distances, some even travelling around the world.

Although these high frequency electromagnetic energy waves are all around us, this energy has long been considered impossible to collect on a large scale due to the induction characteristics of the electromagnetic wave as it passes a metallic object. As the wave goes by a wire tuned to resonate at the frequency of the wave, it induces an electrical charge in the wire, but to use this charge, we need another wire to close the circuit and let the charge flow. If we use another wire alongside the first wire and connected to it, the wave induces a charge in it exactly like in the first wire and no current will circulate in the two wires.

This problem of collecting the energy of the wave was solved by the invention of the half-length electromagnetic transformer, but the half-length electromagnetic transformer applies only to the means of collecting the atmospheric energy. The invention of the full-length electromagnetic transformer of this invention, however, allows us to combine the generation of the electromagnetic wave and the electrical converter into one compact unit.

BRIEF SUMMARY OF THE INVENTION

Basically, this unit uses an oscillating electric current to generate an electromagnetic wave, which releases a much greater electric current, and the total electrical energy derived in this manner, is over and above the amount of energy needed to operate the equipment.

It has long been assumed that the only energy involved in high frequency electromagnetic transmission is that supplied by the operator to drive his equipment. The actual energy of the electromagnetic wave is often over a hundred times greater than this since the amount of electromagnetic energy in the earth is practically unlimited, there appears to be no limit to the size of the electromagnetic generators, or to the size of the power plants based on this energy source. This energy is available, world wide, free for the taking.

This energy is related to the light waves and is probably a variation of the light waves, however, the radio type waves are longer than light waves and are vibrating at a lower frequency. Light waves are a source of high energy just for the taking, also. Anything that is brought up to a high heat, will give off light energy. A very small wire in a light bulb, when brought to a high heat will release a light ray of such power that it will go all the way to the moon. This is natural energy, produced by the speed of the earth through space. Using the math of Dynetics, the speed of the earth necessary to give any pound of earth the atomic energy of one pound of uranium, came out exactly the same as the speed of light (186,300 miles per second). The fact that the math came out exactly at this speed leaves little doubt that the speed of the earth through space is the speed of light, and that every pound of material on earth has the energy of one pound of uranium, due to this speed.

The electromagnetic energy in the low frequency range differs from other types of energy, in many ways, but of interest to us is that it is propagated by electrical currents, travels through the air like the light waves, and is detected and may be collected, when it induces an electric charge in a wire.

This is an ideal source of energy. The generators may be hand-held or large enough to replace the biggest power plants. They may be used to drive motor cycles, sleds, autos, trucks, trains, ships and planes. The fact that the output is in the form of electrical energy is, in itself, a great benefit, but the fact that the generating equipment is light and compact is a real plus for all types of mobile equipment.

It is possible that this invention will supply all of the electrical energy needed in the homes making the distribution lines unnecessary, and if used to drive automobiles, our dependence on oil will be a thing of the past. This invention makes possible an abundance of energy, available to mankind any where in the world. Even the poorest nations will have an abundance of energy.

The oscillating equipment that generates the electromagnetic wave used in this invention includes an oscillator, of some type driving a tuned transmitter coil that resonates with a tuned collector coil in a full-length electromagnetic transformer. The induced current is collected in the collector coil and may be rectified and stored in a battery or used to do work. The oscillator circuit is an ordinary oscillator circuit, driven by a tube, crystal or even an electrical arc, and the tuning means and rectification set-up are standard.

The basic element that is novel to this invention is the full-length electromagnetic transformer unit that is made up of two or more metallic pipe like sheaths side by side. The sheaths are not connected together, electrically. Two or more coils are wound in the sheaths.

The transmitter coil uses an insulated wire, which is threaded up through one sheath, and down through another sheath a number of times forming a long flat continuous circuit of wire inside of the pipe like sheaths. And then the collector coil is threaded up through the sheaths, and wound the same way. The two coils may have a different number of turns. The coils are tuned to resonate at the oscillator frequency and an electromagnetic wave is generated in the transmission coil. The wave induces a charge in that part of the collector coil that is in the same sheath, and next to it, and if the wave is moving up in the sheath, the charges of all of the collector wires in that sheath are moving up, and if the wave is moving down, the charges of all of the collector wires are moving down. But the transmitter wave in one sheath does not induce a current in the wires of another sheath, nor does it induce a current in a wire outside of that sheath. This allows a current induced in one sheath to freely circulate in the other sheaths or on an outside wire.

When the transmitter coil is brought up to resonance and broadcasts its electromagnetic wave inside of the sheaths, it benefits us in two ways. It keeps the wave inside of the sheaths and prevents it from spreading far and wide, and it concentrates the wave on that part of the collector coil in the same sheath. Since each of the collector wires are of the same length, say $\frac{1}{2}$ wave length of the electromagnetic wave, and since they are parallel and side by side, a resonant electromagnetic wave induces equal charges in all of the collector wires within the sheath. These induced currents are exactly in phase and are connected in series, so that the voltages add up to an amount proportional to the number of turns.

More than two sheaths may be used with the coils wound inside, or the full length-transformer may be combined with the half-length transformer where the winding is part inside the sheath and part outside of the sheaths. The oscillator may be replaced by an aerial in cases where low power is needed. The inductance coil may be left entirely outside of the transformer, and the coupling made to the transmission coil by magnetic induction. These and other objects, features and advantages of the present invention will become more apparent upon reading the following specification in conjunction with the accompanying drawing figure.

BRIEF DESCRIPTION OF THE FIGURES

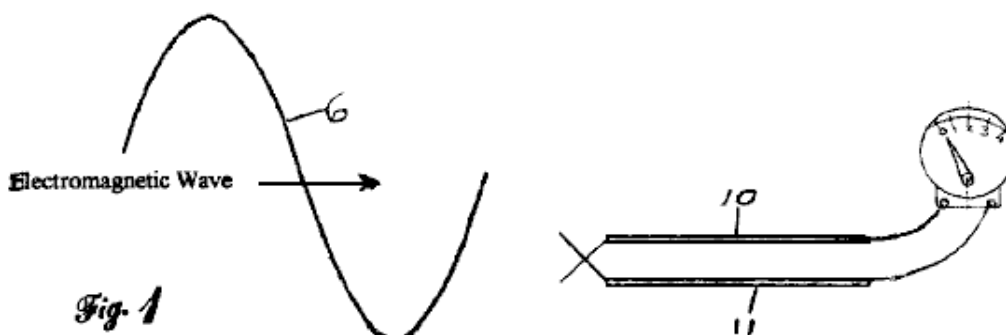

Fig.1 is a view of an electromagnetic wave, due to resonance, passing two side by side wires tuned to the same frequency. The wave generates equal alternating charges in each wire, and no current flows when the wires are connected.

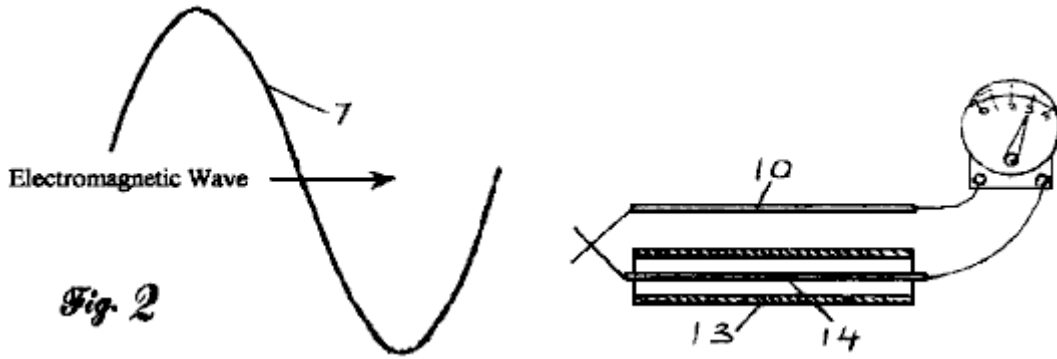

Fig.2 is a view of a resonating electromagnetic wave passing two wires, tuned to resonate, where one wire is surrounded by a metal sheath. The outer metal sheath stops the wave and prevents it from inducing a charge in the shielded wire. The Charge induced in the outside wire now flows freely through the shielded wire.

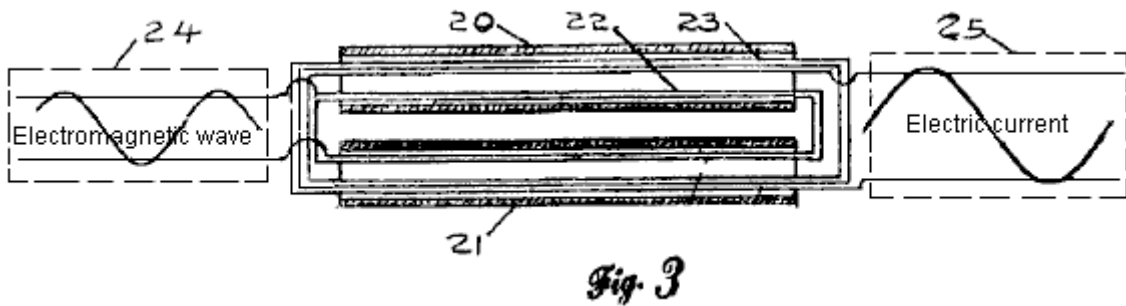

Fig.3 is a view of a full length electromagnetic transformer made of two metallic pipe like sheaths, having two wires threaded up through the inner opening of one sheath and down through the inner opening of the other sheath, a number of times to form two continuous coils. When an electromagnetic wave is fed into the tuned transmitter coil, an alternating current is induced in the tuned collector coil.

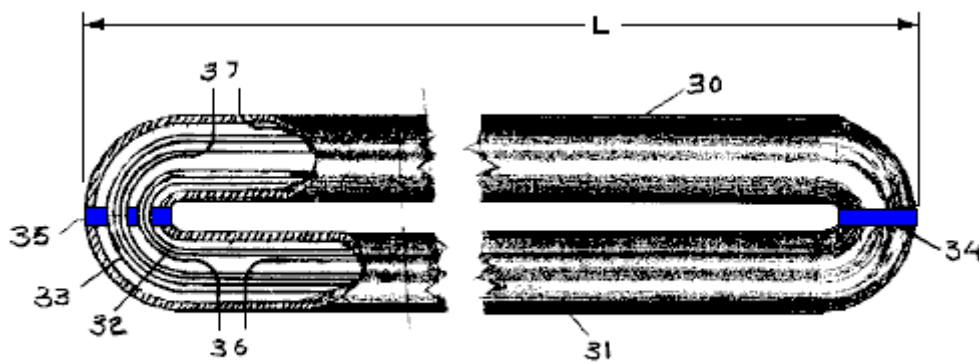

Fig.4 is a view of a full-length electromagnetic transformer, having two sheaths, insulated from each other, and a cutaway portion shows the coils inside.

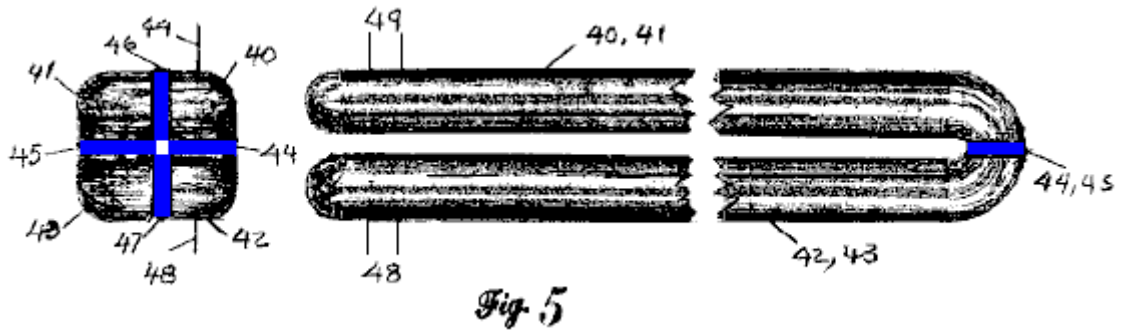

Fig.5 is a view of a full-length electromagnetic transformer, having four sections insulated from each other.

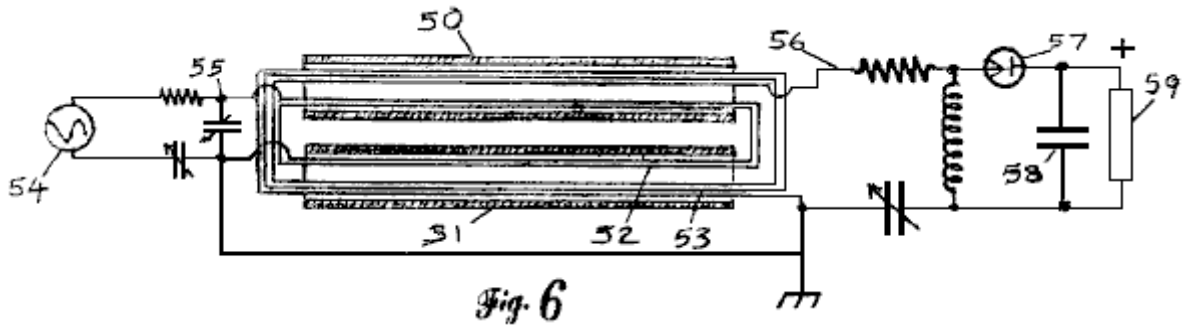

Fig.6 is a section view of a full length electromagnetic transformer made of two metallic pipe like sheaths, where an oscillator circuit is fastened to a tuned transmitter coil, which induces a current in the tuned collector coil; and a half-wave rectifier circuit converts the high frequency current to DC current.

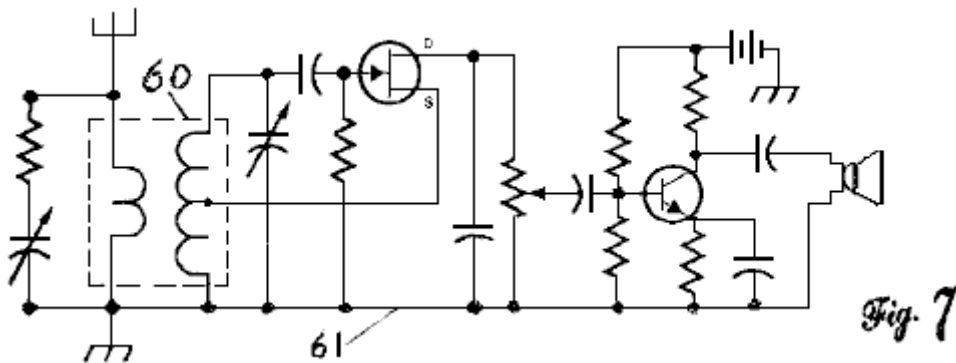

Fig.7 shows a view of a full-length transformer, used as an inductance in a radio receiver or other similar electronic circuit 61. In this case the transmitter coil is between the aerial and ground, and the collector coil acts as the radio frequency inductance.

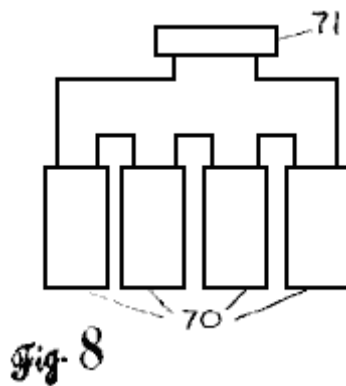

Fig.8 shows a number of full-length transformers, connected in series. They all have rectifiers to convert the high frequency AC current to DC current and the voltages at the load add up.

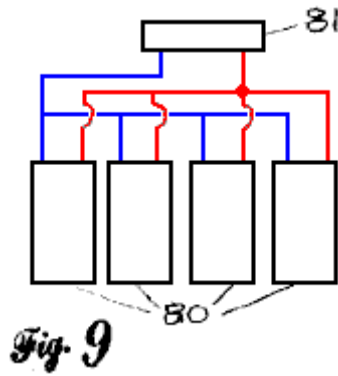

Fig.9 shows a view of a full-length transformer, connected in parallel. In this case the currents at the load add up.

DETAILED DESCRIPTION OF THE PREFERRED EMBODIMENTS

When a circuit is made to resonate at some frequency, it generates an electromagnetic wave. These waves move at the speed of light and travel great distances, and this makes possible our radios, televisions and cell phones. These waves, in passing a wire suspended in the air, set up alternating charges in the wire, varying at the frequency of the wave. If we put an inductance, that is tuned to the frequency of the wave, between the wire and the ground the circuit will resonate and charges will flow back and forth on the wire. This allows us to pick out the wave we are interested in, amplify it and read its message. We have long known that the voltage of the wave we choose to receive is greatly amplified when we make our circuit resonate at that wave's frequency, but we have been unable to accumulate this additional energy from the wave because we are limited to what energy we can pick up by the equipment that we use.

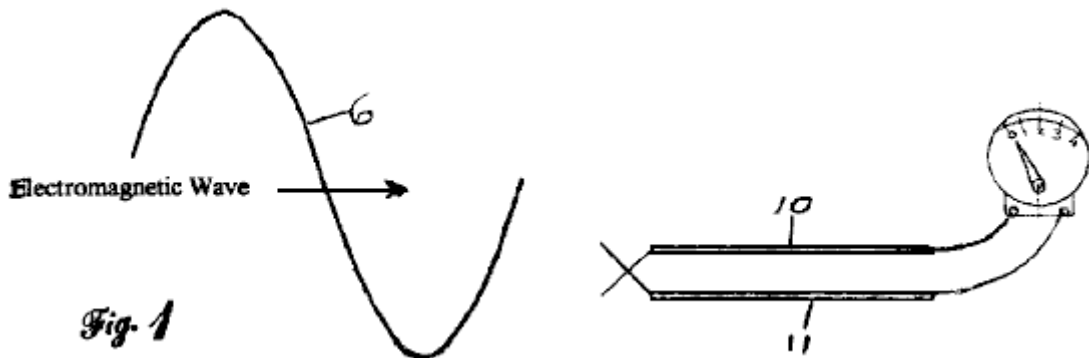
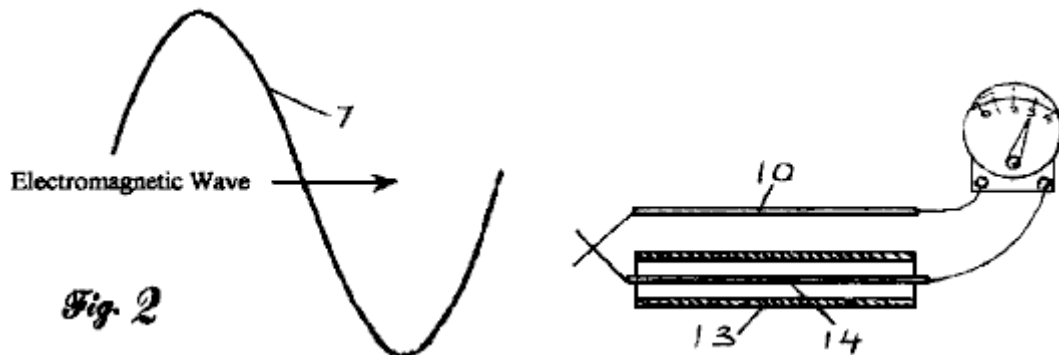

Fig.1 shows why this is so. The passing electromagnetic wave 6 generates an alternating electric charge in the wire 10, tuned to the wave frequency to close the circuit so that the induced charge can circulate, we have added a second wire 11, but if we connect the ends of the wires together, the electromagnetic wave 6 induces a charge in the second wire exactly like the one in the first wire, and no current will flow. Any effort to circulate the charge induced in wire 10 is blocked by an equal opposing charge in 11.



In **Fig.2** we have replaced the wire 11 with a metallic, pipe like sheath 13 having an insulated wire 14 inside when an electromagnetic wave 7 passes, the wave is stopped at the sheath 13 and does not induce any charges in the inner wire 14. This allows the inside wire 14 to conduct the charge induced in the wire 12.

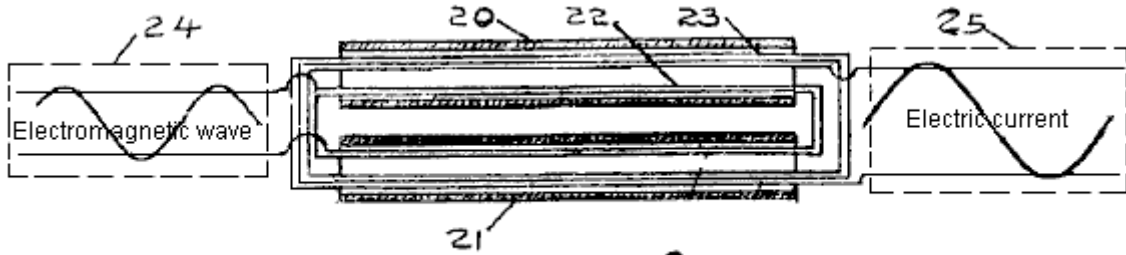

Fig. 3

In **Fig.3** we see two sheaths **20** and **21**, parallel and insulated from each other. Two separate coils **22** and **23** are wound inside the sheaths. The coil **22** is the transmitter coil and it is tuned to resonate at the frequency of the oscillator circuit **24**, and this generates an electromagnetic wave that induces a current in the collector coil **23**, which is adapted and used in the tuned collector circuit **25**.

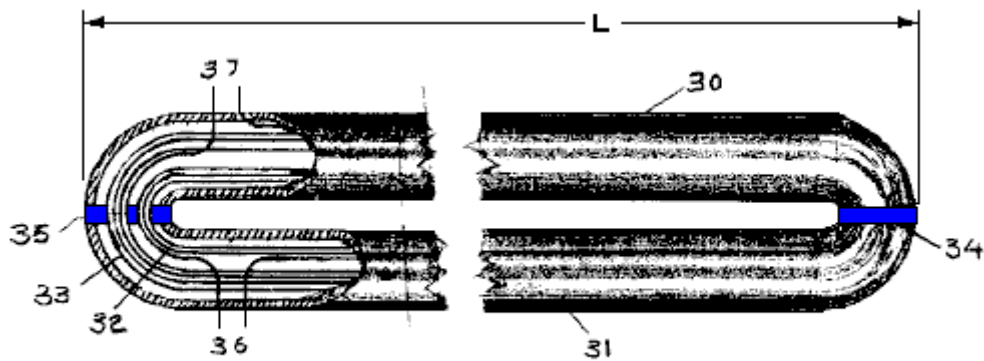

Fig. 4

Fig.4 is a view of a full-length electromagnetic electric generator using two separate sheaths **30** and **31**, where the electromagnetic wave is almost completely contained within the sheaths. The sheaths are parallel and insulated from each other by insulators **34** and **35**. The transmitter coil **32** and the collector coil **33** are shown in the cut-away, and are wound completely inside the sheaths. Additional coils may be added as needed. The transmitter coil **32** is tuned to resonate at the frequency of the oscillator circuit, which connects in at **36**. And this generates an electromagnetic wave that is contained within the sheaths and induces a current in the collector coil **33**, which is tuned to resonate at the wave frequency and is coupled to the collector circuit at the terminal **37**. The insulating separators **34** and **35** are necessary to prevent induced current from flowing in the sheaths **30** and **31**.

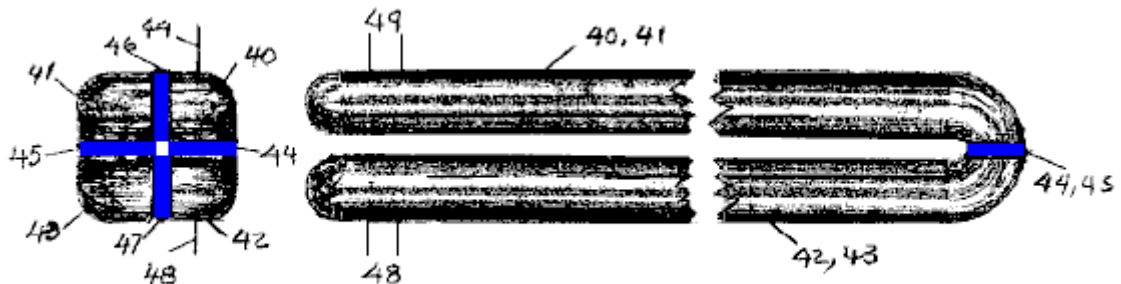
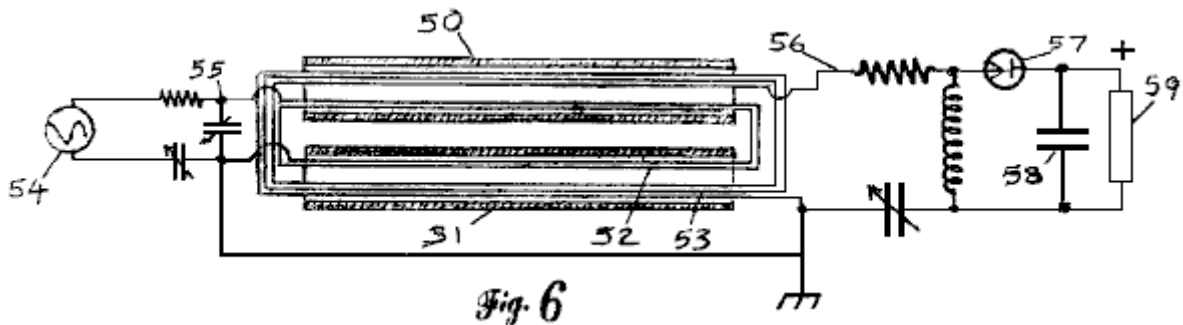

Fig. 5

A number of sheaths may be combined, as is shown in **Fig.5**. In this case four sheaths **40**, **41**, **42** and **43** are combined, so that the coils wound inside the sheaths are in series, and the sheaths are electrically separated by the insulators **44**, **45**, **46** and **47**. The tuned circuit for the transmitter coil is hooked up at connectors **48**, and the collector circuit connects to the collector coil at **49**.



A simple circuit for operating the full-length electromagnetic transformer is shown in **Fig.6**. The two sheaths **50** and **51** are shown with the transmitter coil **52** and collector coil **53**. The transmitter coil is connected to the tuned circuit **55**, which is driven by the oscillator **54**. The oscillator **54** is tuned to oscillate at some frequency and the transformer circuit **55** and collector circuit **56** are tuned to resonate with it. At resonance the transmitter coil **52** emits an electromagnetic wave which induces a current in the collector coil **53**. Shown here is a half-wave rectifier **57** and capacitor **58** connected to the load **59**. The rectifier is necessary on each collector unit, because we can add the direct currents of the separate units, but the alternating currents of the units might be out of phase and without the rectifier they would cancel out.

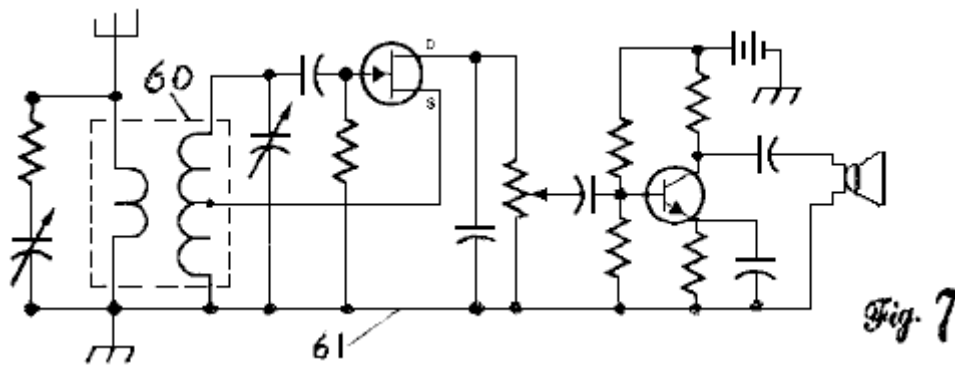
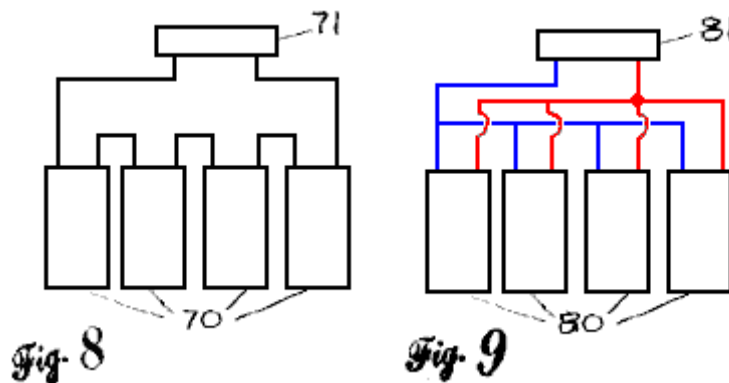

Fig.7 shows the transmitter coil connected between an aerial and the ground, where the aerial circuit and collector circuit are tuned to resonate at a desired frequency to greatly boost the sensitivity and to amplify the signal. This type application will work equally well with transmitters.

Also, using the half-length transformer as an aerial and the full-length transformer as the radio frequency transformer works the same with both receivers and transmitters. The oscillator circuit can use a high frequency magnetic inductance and the full-length transformer unit to resonate with a half-length transformer which acts as an aerial. A unit such as this would greatly add to the power of a radar system.



The full-length units, when combined with rectifiers, may be connected in series as in **Fig.8**, or in parallel as in **Fig.9**

While the invention has been disclosed in its preferred forms, it will be apparent to those skilled in the art that many modifications, additions, and deletions can be made therein without departing from the spirit and scope of the invention and its equivalents as set forth in the following claims.

Claims:

1. An electric generator that uses an oscillating circuit to resonate with inductances enclosed in a full-length electromagnetic transformer unit, comprising: two or more parallel, metallic, pipe-like sheaths, insulated from each other; an electromagnetic transmitter coil, which is wound inside the sheaths, using an insulated wire, threaded up through the inside opening of one of the sheaths and down on the inside of a second sheath, one or more times, to form a continuous coil; a means of tuning the transmitter coil to the frequency of the oscillating circuit, so that the transmitter coil resonates and generates an electromagnetic wave that is contained within the sheaths; a collector coil composed of an insulated wire, threaded up through the inside opening of one of the sheaths and down on the inside of a second sheath, one or more times, to form a continuous coil, wherein the electromagnetic wave of the transmitter coil induces an electric charge in the collector coil; and a means of tuning the collector coil to resonate at the frequency of the oscillating circuit; so that the electromagnetic wave induces a current in the collector coil, and since the coil is contained within the sheaths, the current is free to flow, and the high frequency alternating current, so generated, can be used elsewhere in an electronic circuit, or altered and used as a power source.
2. The full-length electromagnetic transformer unit of claim 1, where the collected current is rectified, and the DC current is stored in capacitors and used to do work.
3. The full-length electromagnetic transformer unit of claim 1, where the transmitter coil acts as a tuned inductance, in a receiver, between the aerial and the ground, and a tuned collector coil resonates to increase the sensitivity and the amplitude of the signal.
4. The full-length electromagnetic transformer unit of claim 3, where the tuned transmitter coil resonates with an oscillator and an aerial to act as a transmitter for radios, televisions, cell phones, radars and computers.
5. The full-length electromagnetic transformer unit of claim 1, where the lengths of the sheaths are some multiple of the wave length of a particular electromagnetic frequency.
6. The full-length electromagnetic transformer unit of claim 5, where a number of the units are connected in parallel to increase the current.
7. The full-length electromagnetic transformer unit of claim 5, where a number of the units are connected in series to increase the voltage.
8. The full-length electromagnetic transformer unit of claim 5, where the parts are reduced to a size small enough to fit in, and supply power to, a cell phone, a lap-top computer, or other electrical appliance.
9. The full-length electromagnetic transformer unit of claim 1 further comprising three or more, metallic, parallel, side by side, pipe like sheaths, where the sheaths are not electrically connected, and have two or more coils wound inside the sheaths.

Up to the present time (June 2013), I have not heard of anyone attempting to replicate the design shown in this patent, and so it is just being put forward here in case somebody wants to try it. It appears to be a clever technique. The power gain is maximised by tuning the transmitting and receiving coils to the frequency of the oscillator, although in practice, it is highly likely that the oscillator frequency would be adjusted to the transmitter coil as it is so easy to adjust the frequency of an oscillator.

Boyd does not go into great detail about attaining resonance, and that is generally a major difficulty in any design which does not have automatic tuning. It needs to be borne in mind that the length of wire in each coil (and possibly its weight) is a key factor. Boyd talks about the coils possibly having the same number of turns, and that is fine **provided** that the coils are identical in size, that is, having the same shape when viewed from the top and the same depth of turns when viewed from the side, and exactly the same number of turns with each coil having exactly the same wire length. Resonance in a length of wire, whether it is laid out straight or wound into a coil, tends to confuse many people. Richard Quick's very clear explanation of resonance in any length of wire, in his US patent 7,973,296 of 5th July 2011 is very helpful. He says:

“Quarter-Wave” Resonance; Standing Electromagnetic Waves”

One of the two main types is electrical resonance is referred to here as quarter-wave resonance. This type of resonance depends almost entirely on the length of a wire element. For reasons described below, if a segment or length of wire is one quarter as long as the “voltage waves” which are travelling through the wire, then a set of

“reflected” waves will be added to the emitted waves, in a synchronised alignment which creates stronger “superimposed waves”.

Accordingly, an understanding of the “quarter-wave” phenomenon will help a reader understand how a straightforward and easily-controlled factor (i.e., the length of a wire ribbon which will be used to form a spiral coil) can help create a “quarter-wave” resonant response, which will create the types of electromagnetic pulses and fields referred to as “standing waves”.

The speed at which a voltage impulse is transmitted through a metal wire is extremely fast. It is essentially the same as the speed of light, which travels 300 million meters (186,000 miles) in a single second (that distance would circle the earth more than 7 times).

If wavelength (in meters) is multiplied by frequency (cycles per second), the result will be the speed of light, 300 million meters/second. Therefore, the wavelength of an “alternating current” (AC) voltage, at some particular frequency, will be the speed of light, divided by which frequency.

Therefore, using simple division, if an alternating voltage operates at a frequency of 1 megahertz (MHz), which is a million cycles per second, then the “wavelength” at that frequency will be 300 meters. If the frequency halves become 500 kilohertz, the wavelength becomes twice as long (600 meters); and, if the frequency were to increase to 2 megahertz, the wavelength drops to 150 meters.

It should be noted which the term “cycles” is what scientists call “a dimensionless unit”, which drops out and becomes silent when other physical terms are multiplied or divided.

At AC frequencies of 10 kilohertz or greater, the common references to “alternating current” (AC) voltage begin using a different term, which is “radio-frequency” (RF) voltage. Accordingly, RF voltage is a form (or subset) of AC voltage, which operates at frequencies higher than 10 kilohertz. RF power generators are readily available, and are sold by numerous companies which can be easily located by an Internet search, using the term “RF power generator”. For example, Hotek Technologies Inc. (hotektech.com) sells two RF power generators, called the AG 1024 and AG 1012 models, which can provide output power at frequencies ranging from 20 kHz to 1 MHz; the 1012 model has a power output of 1000 watts, while the 1024 model has a power output of 2000 watts. The output frequency of any such RF power supply can be adjusted and “tuned” across the entire range of operating frequencies, merely by turning knobs or manipulating other controls in a power supply of this type.

In a wire having a fixed and unchanging length, the easiest way to create a “standing wave” is to adjust the RF frequency emitted by a power supply with an adjustable frequency, until the “tuned” frequency creates a wavelength which is 4 times as long as the wire. This principle is well-known to physicists, and it is commonly referred to as “quarter-wave” behaviour, since the length of the wire segment must be one quarter as long as the wavelength. Since it is important to this invention, the principles behind it are illustrated in a series of drawings provided in **Fig.1** to **Fig.4**, all of which are well-known prior art.

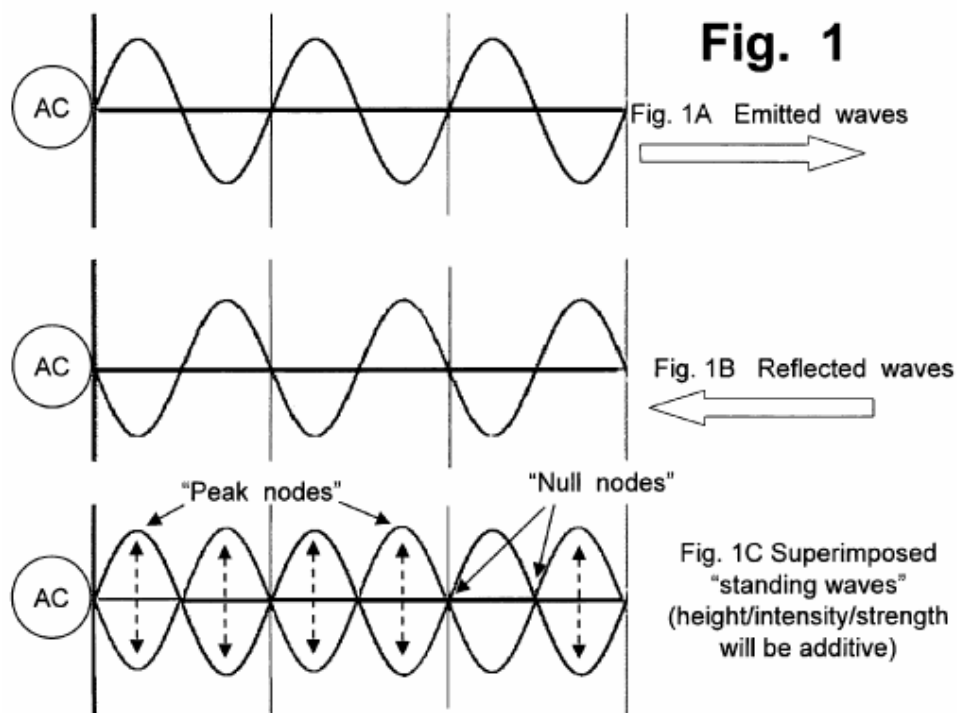

Fig.1A indicates an idealized wavelength of an alternating voltage, depicted by a sine wave which is being sent from an AC power supply (shown by a circle at the left end of a horizontal straight wire) into the “input” end of the wire. The voltage waves travel through the wire towards the right, as indicated by the block arrow in **Fig.1A**. When the waves reach the end of the wire, they cannot leave the wire (at least, not in a simplified and “ideal” system, which is being assumed and used here to explain the principle of how a simple straight wire can create a standing wave). Therefore, the voltage wave will effectively “bounce” or “reflect” back from the tip of the wire, and the “reflected wave” will begin travelling back through the wire, going in the opposite direction, as indicated by the left-pointing block arrow in **Fig.1B**.

Because of the laws of conservation of energy, the reflection and “return travel” of these types of waves, when they bounce off the tip of a wire, is actually quite good, and rather efficient, as discussed below, provided which the wire tip does not emit sparks, arc discharges, or other forms of “escaping” electrical energy.

Accordingly, **Fig.1A** depicts a set of “emitted waves” travelling towards the right, while **Fig.1B** depicts an idealised set of “reflected waves” travelling toward the left along the same wire.

Fig.1C illustrates what happens when both sets of waves (emitted and reflected) are superimposed on each other. Since the two sets of waves are travelling at exactly the same speed, and since they have exactly the same wavelength, they will create a “standing wave” pattern when they are added together. As can be visualised from **Fig.1C**, there will be a set of locations, along the length of the wire, which can be referred to as “peak nodes”, where the AC voltage reaches it’s maximum.

At a location halfway between a pair of adjacent “peak nodes”, there will be a spot which can be called a “null node”, a “zero node”, a trough or valley node, or similar terms. At each “null node” location, the AC voltage will appear to be not fluctuating at all. Those are the sites, along the length of the wire, where each “positive” hump (created by a sine wave travelling toward the right) will be counter-balanced and offset by a “negative hump” with exactly the same height, travelling at an identical speed toward the left.

As a result, this type of response within a wire creates a “standing wave”. If the instantaneous voltage is measured at a “null node”, it would appear that nothing is happening, in terms of fluctuating voltage. Furthermore, the “null node” will not be moving, along the length of the wire; instead, it will appear to be standing still.

This can be demonstrated, in a coil, by using a “grounded lead” to test for voltages along the length of a coil. If a “grounded lead” coupled to a volt meter is used to touch the surfaces of a series of strands in a non-insulated coil (such as a coil made of thin copper tubing, wrapped around a plastic cylindrical shape, as used in the types of large transformers used by hobbyists to create “Tesla coils” which will emit large and visually impressive electrical arcs), the “test lead” will detect no apparent voltage at a null node, which will occur at some particular strand in the coil. At a different strand of the coil, the “test lead” will detect an alternating voltage which has twice the strength and intensity of the voltage being emitted by the power supply.

If voltage is measured at a “peak node”, the voltage will be doing something which can be called, using vernacular or laymen’s terms, “the full-tilt boogie”. The AC voltage levels will be moving back and forth, between: (i) a very high and intense positive voltage, to (ii) an equally intense negative voltage. This is indicated by the “bubble” shapes shown along the wire in **Fig.1C**.

The “bubbles” which are shown in **Fig.1C** can help someone understand how standing waves are created, and how they act in a synchronised manner. However, which drawing fails to show another result which is very important in what actually happens in a standing wave. For purposes of description and analysis at this introductory level, the system can be assumed to be “ideal”, which implies a perfect “mirror-image” reflection of each wave from the right end of the wire. An “ideal” system also implies that no reflections occur at the left hand end of the wire where the power supply is located, and all “reflected” wave activity simply ceases. In real circuits and wires of this type, second and third order reflections do in fact occur, and they are used to further increase the strength and power output of these types of systems; however, those additional factors and “harmonics” should be ignored until after the basic principles of this type of system have been grasped and understood.

In an ideal system, when the reflected waves (which are travelling toward the left, in the wire segments illustrated in **Fig.1**) are “superimposed” on the emitted waves (travelling toward the right), the “peak” positive voltage which will be instantaneously reached, at the highest point of each “bubble” shown in **Fig.1C**, will occur when the positive peak of an emitted wave crosses a mirror-image positive peak of a reflected wave, travelling in the opposite direction. Accordingly, when those two “positive peak” values are added to each other, the instantaneous positive peak voltage which will occur, in the wire, will actually be twice as intense as the “positive peak” voltage being emitted by the AC power supply.

An instant later, at that exact point on that segment of wire, a negative peak voltage will be created, which will be the sum of (i) the negative peak voltage emitted by the power supply, and (ii) the negative peak voltage of a reflected wave also will pass through, travelling toward the left. At which instant, when those two negative peak voltages are added to each other, the instantaneous negative voltage which will occur, in the wire, will be twice as intense as the “negative peak” voltage being generated by the AC power supply.

A more accurate and representative visual depiction of a “standing wave” in a wire would actually show the heights of the peaks as being twice as tall as the peaks of the emitted voltage waves, and the reflected voltage

waves. However, which depiction might confuse people, so it usually is not shown in drawings of “standing waves”.

Accordingly, the instantaneous response in the wire, at a location halfway between two “null nodes”, is doing something which can fairly and properly be called “the full-tilt double double boogie”. The “double double” phrase (note which it contains not just one but two “doubles”) was added to that phrase, for two reasons:

(i) To emphasise the fact that each and every voltage peak (maximum positive, and maximum negative) will be twice as strong, and twice as intense, as the maximum positive and negative peak voltages emitted by the power supply; and,

(ii) to point out that the frequency of the superimposed “bubbles”, shown in **Fig.1C**, is actually twice as fast as the frequency of the AC cycle which is emitted by the power supply, as discussed below.

The “twice the intensity” result is directly comparable to what an observer will see, if a large mirror is placed behind a light bulb in an otherwise dark room. The mirror effectively keeps the room dark, everywhere behind the mirror, so there is no “magical doubling” of the light in the room; which would violate the basic law of conservation of energy. Instead, what the mirror does is to shift light away from the backside of the mirror, and keep that light energy on the reflective side of the mirror. Anyone standing in front of the mirror will see two apparent light bulbs. Both of those light bulbs (the original bulb, and the reflected image) will have the same brightness (if the mirror is perfect). Therefore, the mirror will double the intensity of the light energy reaching the observer.

That same effect, in a circuit, will happen if the end of a wire acts like a mirror. If a wire does not have any components which will cause it to become an active “emission source” (which is the behaviour of transmission antennas and certain other components), in a way which efficiently releases voltage-created energy into the atmosphere, then the basic rules which require conservation of energy will prevent that energy from simply disappearing and ceasing to exist. As a result, even if the end of a wire is not designed to be a perfect reflector, a large portion of the voltage wave will indeed reflect off the wire tip, and travel back through the same wire, in a “second pass”.

To understand adequately, the type and amount of “wave reflection” which occurs at a wire tip, consider what happens if a light bulb is shining in a room which has shiny, glossy white paint on all the walls and ceilings; then, consider how it would look if the same light bulb were located in a room with all of the walls and ceilings painted “matt black”. The total amount of light which would be available, to carry out a task such as reading a newspaper, clearly would be much greater in the white room, because light reflects off white paint, even though white paint does not even begin to approach the type of “reflection quality or clarity” which a mirror creates. The difference in what happens, when light intensity in a room painted matt black is compared to a room painted a glossy white, does not arise from the presence or absence of “reflection quality or clarity”; instead, it is governed by the laws of conservation of energy. When light shines on to a surface which is painted matt black, the light energy is absorbed by the paint, and it literally warms the paint up. In contrast to that, glossy white paint will not absorb light energy, so it reflects the light back out, for a “second pass” through the air which fills a room.

Because of the laws of conservation of energy, and without depending on any “quality of reflectance” characteristic of wire tips, electrical energy cannot simply disappear, when it reaches the end of a wire. Instead, there are only two things which can happen to that energy:

(i) the electrical energy can be emitted into the surroundings, such as by emitting sparks, arcs, or radio-frequency signals which will carry energy; or

(ii) if the energy is not emitted by the tip of the wire, then, by simple necessity and because of the basic law of conservation of energy, it must be reflected back into the wire, and it will be forced to travel back through the wire again.

If a wire has a long and tapered tip, then the reflected wave might become somewhat diffused, and it might lose some portion of the “clarity” of the wave. However, since wavelengths in the frequencies of interest here are hundreds of meters long, the type of tip created by a conventional wire cutter will not create any significant diffusion, in a reflected wave. And, unlike the white-painted walls of a room, there is not a large area which is available, at the tip of a wire, which can create scatter, spread, or diffusion. As a result, the tip of a wire will be a relatively efficient mirror-type reflector, when an AC voltage is “pumped” into one end of the wire.

The second factor mentioned above, when the “double-double” boogie phrase was mentioned, relates to a doubling of the frequency of a standing wave. When a standing wave is created in a wire by reflection of an emitted AC voltage wave, the frequency of the standing wave is, quite literally, double the frequency of the emitted wave.

This can be seen, visually, by noting that in the emitted AC voltage, shown in **Fig.1A**, a single complete wavelength contains both a “positive hump” and a “negative hump”. Accordingly, three complete sine waves, divided into three segments by the imaginary vertical lines, are shown in **Fig.1A**.

By contrast, each and every “bubble” shown in **Fig.1C** depicts a complete and total “wavelength”, in a standing wave. Six of those standing wave “bubbles” fit into exactly the same length of wire which holds only 3 emitted wavelengths from the power supply.

The “frequency doubling” effect of standing waves is important, because AC systems can convey and release energy in a manner which increases, as the frequency of the AC voltage supply increases. To some extent, this is analogous to saying that, if a motor can be run at twice the speed (while still generating the same torque), then the work output of that motor can be twice as great, at the higher speed. That analogy is not entirely accurate, since work output from an electric device which uses AC power depends on “area of the curve” functions which occur when sine waves are involved. Nevertheless, as a general principle, if the frequency of the voltage peaks increases, then power output will also increase, in many types of electric circuit components.

In the three panels of **Fig.1**, the wire length is three times as long as the wavelength of the voltage from the power supply. However, to create standing waves, a wire length does not need to be any particular multiple of the wavelength of an AC voltage. As can be seen by considering **Fig.1C**, the same types of “bubbles” would be created: (i) if the wire length were exactly twice as long as the wavelength; or, (ii) if the wire length were the same length as the wavelength.

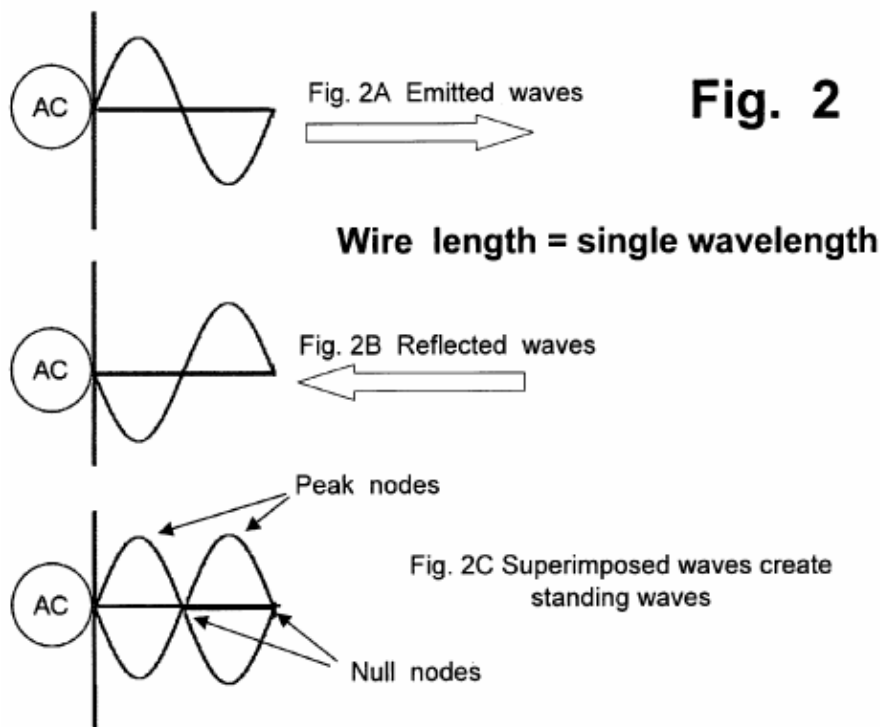

Accordingly, **Fig.2** (which includes **Fig.2A** showing an emitted wave, **Fig.2B** showing a reflected wave, and **Fig.2C** showing the superimposed “bubbles”) shows what happens in a wire segment which has a length which is equal to a single wavelength from an AC voltage at a fixed frequency. A resonant standing wave will be formed, with a frequency which is double the frequency of the input AC voltage. which same result will apply, in a wire having any length which is an exact (integer) multiple (such as 1x, 2x, 3x, etc.) of the wavelength of the AC voltage being pushed (or forced, driven, pumped, etc.) into the wire segment.

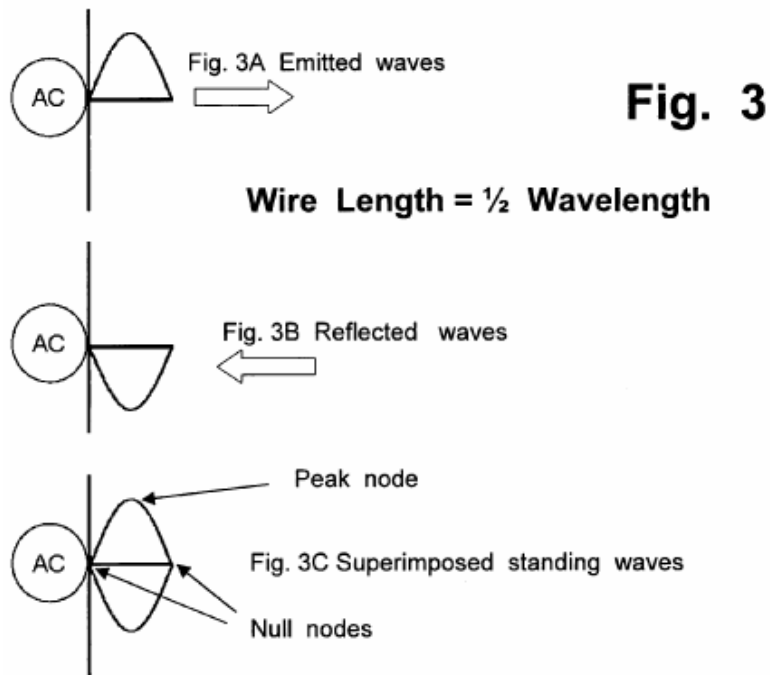

Moving to still shorter wires, the same principle also applies to any wire with a length equal to one half of an AC voltage wavelength. As shown in **Fig.3** (which includes **Fig. 3A** showing an emitted wave, **Fig. 3B** showing a reflected wave, and **Fig. 3C** showing the superimposed “bubbles”), if the wire length is one half of the wavelength, a natural and resonant standing wave will still form, with a frequency which is double the frequency of the input AC voltage.

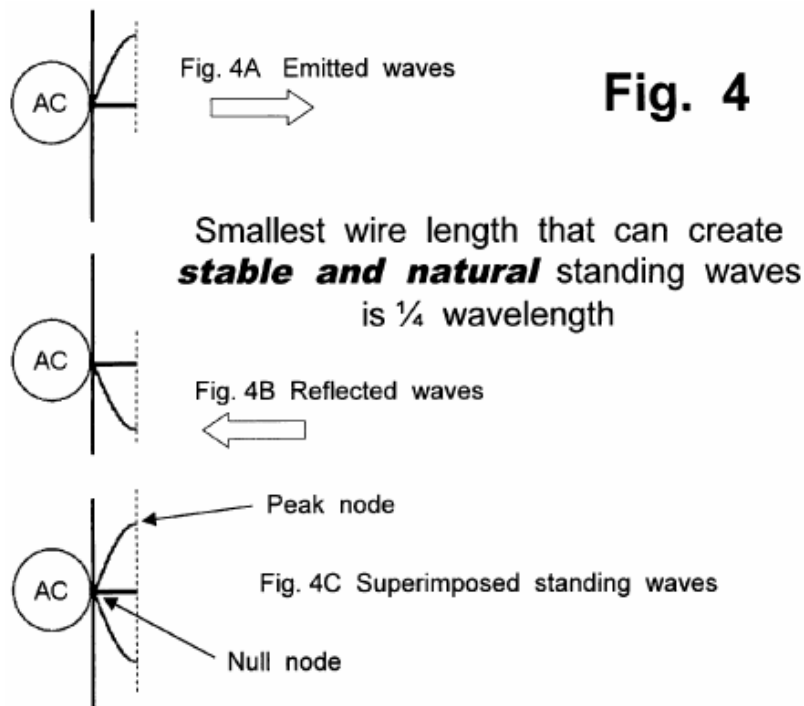

Finally, moving to a still shorter wire, the same principle also applies to any wire which has a length equal to one quarter of an AC voltage wavelength, as shown in **Fig.4A**, **Fig.4B**, and **Fig.4C**. Even though it does not stretch across or cover a complete “bubble”, the standing wave shown in **Fig.4C** is nevertheless a stable, natural, and resonant “standing wave”, with a frequency which is exactly twice the frequency of the input AC voltage.

It is possible to create partially stable and semi-resonant responses, using one eighth, one sixteenth, or shorter lengths of wire, by using additional devices which can remove electrical power from the system, or which can generate effects which are usually called “harmonics”. However, those are not the types of natural and stable responses which can be created by a simple, basic system consisting of nothing more than: (i) a wire having a fixed length and a “reflective” tip; and (ii) an AC power source with a frequency which can be “tuned” until it creates a resonant response in any wire segment having a suitable length.

Therefore, since quarter-wave wire lengths are the shortest lengths which can create natural and stable standing waves, the conventional term which is commonly used, to describe what happens when a wire creates a resonant standing-wave response, is a “quarter-wave” response.

In some devices, telescoping components (or other elements which can alter the effective length of a wire-type element) can be used to alter the ability of the element to respond to a fixed wavelength. Many types of antennas use this approach, if they need to process signals which are being transmitted on fixed and known frequencies. However, those examples are not relevant to spiral coil reactors, which will use an approach which involves tuning and adjusting the frequency of the voltage which is being supplied to a reactor, until a resonant response is observed in coils with fixed and unchanging lengths.

It should also be noted that certain types of “tuning” elements (such as capacitors, which can have either fixed or adjustable capacitance levels) can also be coupled electrically to a wire, in a manner which “emulates” adding more length to that wire. This approach can be used to alter (or increase the range of) the frequencies to which a wire circuit will respond resonantly.

The ‘Gegene’ Magnetic Arrangement.

As we have seen from what Don Smith has said, a very effective method of gaining additional power is to make a high frequency magnetic transmitter as that allows several outputs to be taken from the transmitter without increasing the input power in any way. Recently, a clever idea for a simplified version of this has been shared on the web. As far as I am aware, this device was first presented by the Lithuanian ‘FreeEnergyLT’ whose website is at <http://freeenergylt.narod2.ru/dynatron/>



and the information then replicated and documented by J L Naudin on his website <http://jnaudin.free.fr/gegene/indexen.htm> and named ‘Gegene’ being short for ‘Great Efficiency Generator’. The clever idea is to use a commercial induction hot-plate as the transmitter. These have recently become available at low cost, this one:



Sold in the UK by Maplin, has power levels adjustable from 300 watts to 2000 watts, and costs only £30 delivered to your address. These devices operate by generating a powerful high frequency oscillating magnetic field which induces eddy currents in any magnetic material placed on the surface of the cooker. That is, cookware which is made of cast iron or steel (not stainless steel which is supposedly non-magnetic). The heating is very rapid and completely uniform across the item of cookware which is very helpful when cooking. The hot plate is controlled by sophisticated electronics which will not switch on unless there is an iron object on the plate and which varies the frequency and current in a way chosen by the designer.

The circuitry produces the magnetic field by pulsing current through a large, flat coil in the centre of the case as can be seen in this photograph of a typical induction plate with the case opened:

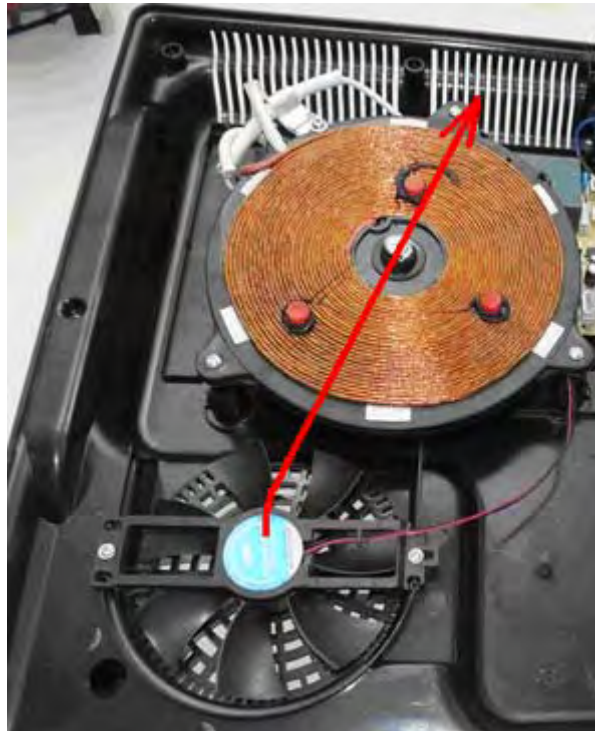

The brown coil gets hot, and so there are spacers on it to prevent the cool outer casing from picking up the heat of the coil. There is also a fan which draws air in from underneath the case and blows it across the coil in order to keep the heat down.

In order to use this magnetic transmitter, we need to place a suitable output coil on the plate, and power a load from the energy collected by that coil. This is a fairly recent idea and so there is still a good deal of experimentation going on, testing different coils, and various loads. It is generally agreed that the best load is a non-inductive load with halogen lamps and ordinary filament light bulbs being recommended. Halogen lamps are used in some low-cost commercial heaters, and they are very effective method of radiant heating. In his video at <http://www.youtube.com/watch?v=LbAhUwHvJCE>, Laurent powers seven separate 400-watt halogen lamps using a small 800-watt maximum plate which has a small 120 mm diameter transmitter coil:



No particular power output is claimed by Laurent, but as you can see, the 2800 watts of halogen lamps are brightly lit while a wattmeter on the input to the plate reads just 758 watts. It seems to be fairly clear that there is a significant power gain with this arrangement. Then, Laurent places an additional coil on top of the first one and shows it lighting a 100-watt filament light bulb very brightly:



It is actually quite difficult to see the brightness of lamps shown in a video as the video camera automatically turns down the brightness of the recording. The important point here is that there is significant power output from a second coil, without there being any increase in the power input to the transmitter coil in the induction plate.

There are many different designs of electronics in commercial induction plates. Most will not start operating until a magnetic object is placed on top of the plate. If that is done, then the object needs to be removed very promptly as it heats up very rapidly. Fortunately, most plate designs keep operating as soon as the induction process is started and so there is no problem with removing the metal cookware (or whatever is used to start the process). Laurent's very small induction plate does not have that protection circuitry and so starts up as soon as it is switched on.

Jean-Louis Naudin uses a 2000-watt induction plate turned down to its 1000-watt setting. It has a 180 mm diameter pick-up coil. He says that for him, it is essential to have at least 1500-watts of load or else the induction plate will shut down with an error code indicating that no cookware is present.

The coils used are Tesla bi-filar pancake types, typically, attached to a thin sheet of MDF or plywood, say 2 mm thick, with superglue. Laurent's 120 mm coil has ten turns and Jean-Louis' 160 mm coil has sixteen turns, needing about 5 metres of twin-core wire, and Laurent's about 2.5 metres of wire. I suggest that the wire should be rated for mains voltage and have, perhaps 1 sq. mm cross-sectional area of copper wire in each conductor. A Tesla pancake coil is wound like this:

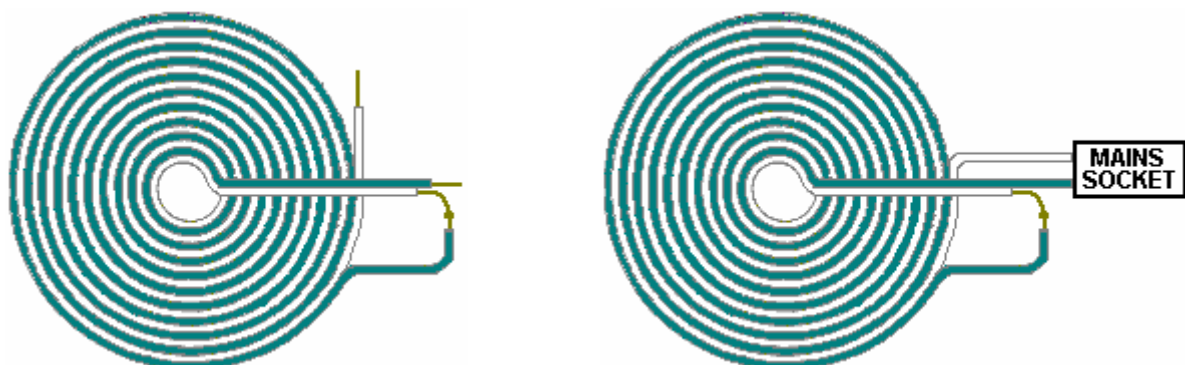

Please remember that this arrangement involves high voltages and so is not suitable for newcomers to electronics. This presentation is strictly for information purposes only and it is not a recommendation that you attempt to implement anything shown here, and if you choose to do so, then the responsibility is yours and yours alone.

Tariel Kapanadze's Self-Powered Generators

Tariel Kapanadze, like Don Smith, appears to have based his work on that of Nikola Tesla. There has been a video on the web, of one of his devices in operation, but it appears that the video has been removed. However, part of it can be seen here: <http://www.youtube.com/watch?v=l3akywcvb9g> The video commentary was not in English and so the information gathered from it is not as complete as it might be. However, in spite of that, a number of useful things can be learned from it. Unfortunately, Tariel refuses to share the details of his designs.



The video shows a demonstration being staged in a back garden, I believe, in Turkey. Strong sunshine was casting dense shadows which made video detail less than perfect. Essentially, Tariel demonstrated one of his builds of a Tesla-style free-energy device, powering both itself and a row of five light bulbs.

One of the most encouraging things about this video is that the construction and operation was of the most basic kind, with not the slightest suggestion of expensive laboratory work or anything high-precision. This is most definitely a backyard construction within the scope of any knowledgeable person.

Electrical connections were made by twisting bare wires together:



and where necessary, tightening the twist with a pair of pliers:



This shows clearly that a high-power and very useful free-energy device can be made with the most simple of construction methods - no expensive connectors here, just a zero-cost twisted connection.



The device being displayed is a Tesla Coil powered, earth-connected system of the type already described. You will notice that the thick primary winding is not placed at one end of the central secondary winding but is much closer to the centre of the coil. Remember that Don Smith states that if the primary coil is placed centrally, then the amount of current which the coil can deliver is very large, in spite of the fact that most people think that a Tesla Coil can only produce trivial currents. Notice also that this Tesla Coil appears to be mounted on a cheap kitchen-roll holder. I have seen it said that Taniel makes a new device for each demonstration and takes it apart afterwards, so if that is correct, then it is likely that there is no great effort or expense involved in making one of these systems.

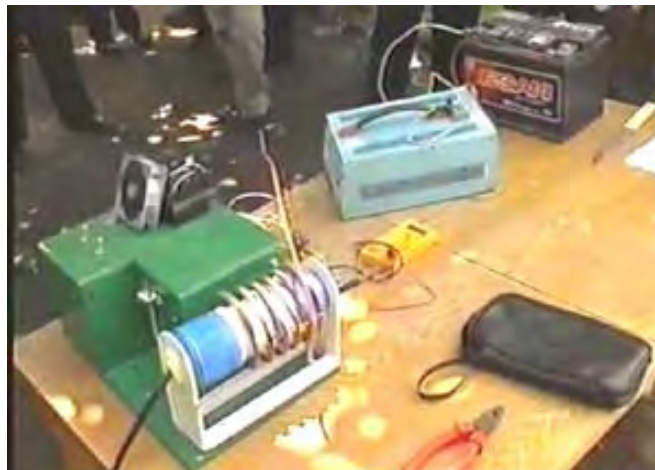

The main operational components are shown here, placed on one small table. There is a lead-acid battery (which is removed later in the demonstration), what appears to be an inverter to produce mains AC voltage from the battery, a high-voltage step-up system housed in a green box for safety reasons, a Tesla Coil, a spark gap mounted on the box and a fan-cooled component, probably a solid-state oscillator system driving the Tesla Coil. Not seen in this picture, is an item contained in a small box which might well be a high-voltage capacitor.

Two earth connections are organised. The first one is an old car radiator buried in the ground:



and the second is a bare wire wrapped around a garden tap's metal pipe and twisted tight as shown above. It is distinctly possible that the circuit is based on this circuit of Tesla's:

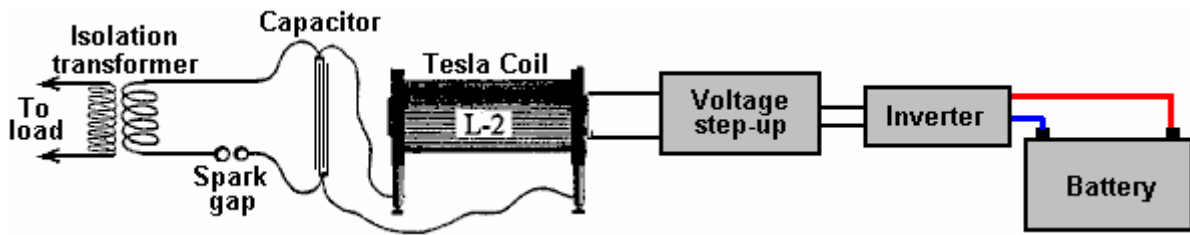

Perhaps, the battery powers the inverter which produces mains voltage, which is then stepped up to a high voltage level by the enclosed electronics. This then drives the Tesla Coil, producing both very high voltage and current with the capacitor storing the energy as a reservoir. The spark gap then pulses this energy, driving the primary winding of the isolation transformer which produces a lower voltage at substantial current (depending on the current-handling capacity of the transformer itself) powering the load, which in this case, is a row of light bulbs.

The load is a row of five light bulbs hung from a brush handle placed across the backs of two chairs:



As you can see, this is not exactly high-tech, high-cost construction here, with all of the materials being used for other things afterwards.

Initially, the battery is used to power the inverter and it is demonstrated that the current being drawn from the inverter is substantially less than the power entering the load. In conventional terms, this appears impossible, which is an indication that the conventional terms are out of date and need to be updated to include the observed facts from demonstrations such as this.

As the system is putting out a good deal more power than is required to drive it, might it not be possible to use part of the output power to provide the input power. This is often called "closing the loop" and it is demonstrated in this video as the next step.

First, the circuit is altered so that the input power connection to the inverter is taken from the output. Then the circuit is powered up using the battery as before. The battery is then disconnected and removed altogether, and the people helping with the demonstration pick up all of the active items and hold them up in the air so as to show that there are no hidden wires providing the extra power from some hidden source. The items on the table are not part of the circuit:



There is some additional information on Tariel including videos of some of his more powerful, newer designs at http://peswiki.com/index.php/Directory:Kapanadze_Free_Energy_Generator#Official_Website although it has to be said that there does not appear to be very much on him or his work available at this time.

In December 2009 an anonymous contributor e-mailed to say that Kapanadze returned to the ex-USSR republic of Georgia and that the video soundtrack is in the Georgian language and after the demonstration, the interview is in Russian. He has kindly translated the parts which relate to the device, as follows:

Question: What are you showing us today?

Answer: This is a device which draws energy from the environment. It draws 40 watts as it starts up, but then it can power itself and provide an output of 5 kilowatts. We don't know how much energy can be drawn from the environment, but in an earlier test, we drew 200 kilowatts of power.

Question: Is it possible to solve the energy problems of Georgia?

Answer: We consider that they have already been solved.

Question: Please tell us in simple terms, how your device works.

Answer: (1) Power is drawn from the battery to get the device running
(2) If we want, we can use part of the output power to drive a charger and charge the battery
(3) When the device is running, we can remove the battery and it then operates self-powered. This particular unit can deliver 5 kilowatts of power which is enough for a family. We can easily make a version which supplies 10 kilowatts. We don't know what the practical power limit is for a unit like this. With this particular device we have here, we do not draw more than 5 kilowatts as we don't want to burn out the components which we used in this build.

Question: Does your invention pick up current from mains wires?

Answer: The mains has nothing to do with this device. The energy produced comes directly from the environment.

Question: What do you call your device and do you dedicate it to anyone?

Answer: I would not dream of claiming this device to be my invention, I just found something which works. This is an invention of Nikola Tesla and all the credit is his. Tesla has done so much for mankind but today he is just forgotten. This device is his invention, his work.

Question: Why are you so sure that this is a design of Nikola Tesla's?

Answer: Because I worked from his invention - his design. I discovered how to get automatic resonance between the primary and secondary windings. The most important thing is to achieve resonance. Melnichenko came close to solving this problem. The government of Georgia refuses to take this invention seriously.

Question: You said that resonance must be maintained. Which parts resonate?

Answer: Here (pointing to the green box) and here (pointing to the Tesla Coil mounted on the top of the green box). The resonator is inside the green box and at present, it is secret until patented.

Question: How much would one of these units cost?

Answer: When mass produced, it would cost between 300 and 400 US dollars for a unit which has an output of 5 or 6 kilowatts.

Question: How much did it cost you to build this demonstration device?

Answer: About eight thousand (currency not specified). Parts had to be got in from twenty different places.

Question: Is this your house?

Answer: No, I rent this place because we have sold all that we have to make these devices. And, having done it, the government and many scientists say "We are not interested because a device like that is impossible and can't possibly exist!". I have not been allowed to make a presentation to them, but people who understand the Tesla Coil understand how this device works.

Kapanadze is an architect by profession and has not had any training in either physics or Electrical Engineering. The information on which this design was based was downloaded free from the internet.

One of the most important aspects of this video is the confirmation it gives for the work of Tesla and of Don Smith, in that it shows clearly, yet again, that large amounts of energy can be drawn from the local environment, without the need to burn a fuel. Another video: <http://www.youtube.com/watch?v=gErefbcTz-U>

People frequently ask for construction drawings or alternatively, outlets where they can buy one of his devices. Unfortunately, Taniel is not willing to share the details of his designs and so they will probably never be manufactured. Many people have tried to analyse and replicate his design.

Kapanadze Analysis by William McFreey

Shown below are two analysis papers on Taniel Kapanadze's designs. These papers by William McFreey are written primarily for physicists, and so they may not be easily understood by you if you are not familiar with scientific symbols and notation, so please feel free to move past this section..

While William McFreey's paper is highly technical, the designs disclosed in it have been prototyped and proved to be fully functional. However, it needs to be understood that there are several ways of extracting free-energy from our local environment. For example:

1. Thomas Henry Moray demonstrated that it is possible to draw kilowatts of energy directly from the local environment, using an aerial of relatively minor dimensions.
2. Stanley Meyer demonstrated that water can be separated into a hydrogen and oxygen gas mix using tiny power levels. This allows an ordinary petrol generator to be run self-powered on water alone.
3. Bob Boyce has produced a pulsed toroidal circuit which allows a battery to recharge itself.
4. Robert Adams produced a motor/generator design where permanent magnets generate an electrical output far in excess of the power needed to operate it.
5. Carlos Benitez designed a system which is self-powered and which provides kilowatts of excess power using just simple, standard electronic components.
6. Thane Heins has built and demonstrated simple asymmetrical transformers where the output power is more than thirty times greater than the input power.
7. Clemente Figuera produced a split-transformer design where the Lenz "Law" effect does not apply and so it produces far greater output power than input power.
8. John Bedini designed a pulsed flywheel motor/generator system which ran self-powered for years. Jim Watson built a large version which had many kilowatts of excess power.
9. Dr Oleg Gritskevitch built a self-powered motionless toroidal generator which produced 1.5 megawatts for two years.
10. James Hardy has demonstrated how the jet of water from a powerful water-pump can spin a generator fast enough to self-power the pump and supply additional electrical power for other equipment.
11. Mikhail Dmitriev has produced a gravity-powered generator which uses a small electrical motor to deflect weights on a rotor and that system produces kilowatts of excess power drawn from the gravitational field.

12. Lawrence Tseung has shown how a magnet embedded in an iron frame produces a greater output than the input power when it is powered with DC pulses.
13. Lawrence Tseung has also demonstrated that a heavy rotor powered by electromagnet pulses can have a substantially greater output power than the power needed to drive it.
14. Veljko Milkovic has demonstrated how combining a pendulum with a lever produces a system which has far greater mechanical output power than the mechanical power needed to operate it.
15. Richard Willis has shown how pulsing a magnetic material can produce kilowatts of excess power.
16. James Kwok has shown that introducing air into the bottom of a tank of water can generate tens of kilowatts of excess power through buoyancy.
17. Dietmar Hohl has published his design where permanent magnets cause permanent rotation of a cylinder without the need for any external source of power.
18. Mummar Yildiz has demonstrated a 300 watt permanent magnet only motor and then taken the motor completely apart to prove that there is no other source of power.
19. Lawrence Tseung has produced a variation on the Joule Thief circuit which has greater output power than the input power (something which I personally have built and can confirm).
20. Floyd Sweet produced a system where a tiny amount of power is used to wobble the magnetic poles of a specially conditioned magnet, producing thousands of times greater output power than the input power needed to power the system.

There are many other proven systems. The two papers from William McFreely can be freely downloaded from: <http://www.free-energy-info.tuks.nl/McFreely.pdf>.

The Cold Electricity Coil of 'UFOPolitics'

A man who uses the forum ID of 'UFOPolitics' has been sharing his insights and experiences on various different forums, such as the one dealing directly with the production and use of cold electricity in solid-state circuits: <http://www.energeticforum.com/renewable-energy/10529-my-motors-got-me-tap-into-radiant-energy-1.html> His insights are unusual and very important. His basic statement is that if a coil is pulsed, using a circuit like this:

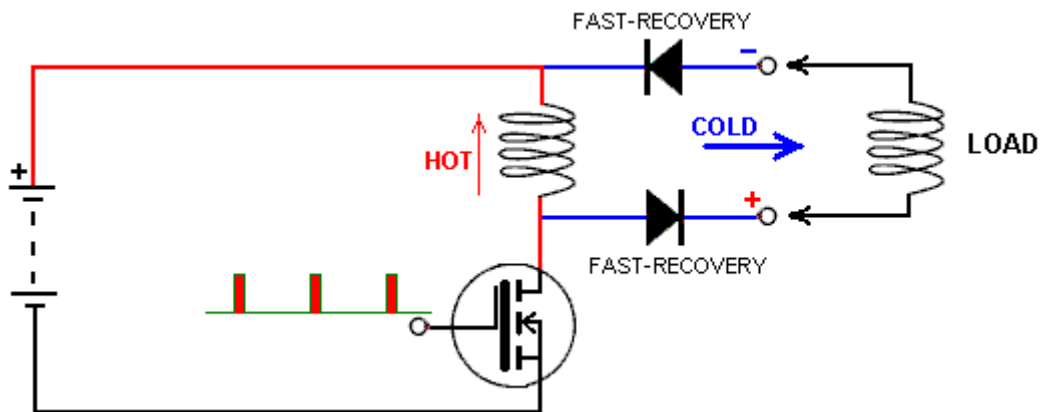

then conventional hot electricity pulses the coil when the transistor is switched ON, but if that current is switched OFF rapidly, then there is an inflow of cold electricity into the coil from the surrounding environment. That inflow of energy can be collected and diverted to power a load through the use of two high-speed diodes which can carry considerable current as the power inflow is substantial. The inflow of energy occurs when the transistor is switched OFF and so it is desirable to have the transistor switched off for most of the time, in other words, a low percentage Duty Cycle for the transistor. There **must** be a significant load on the cold electricity output. If there is not, then the cold electricity will flow back into the hot electricity section of the circuit and it may damage the transistors. Tom Bearden states that resistors boost cold electricity rather than hindering it's flow, so the load should be a coil, a DC motor with brushes or a fluorescent light bulb.

It has been observed that the incoming energy tends to flow inwards towards the centre of the coil, so an additional method of collecting this extra energy is to place a second coil inside the main coil, and wound in the same direction as it, like this:

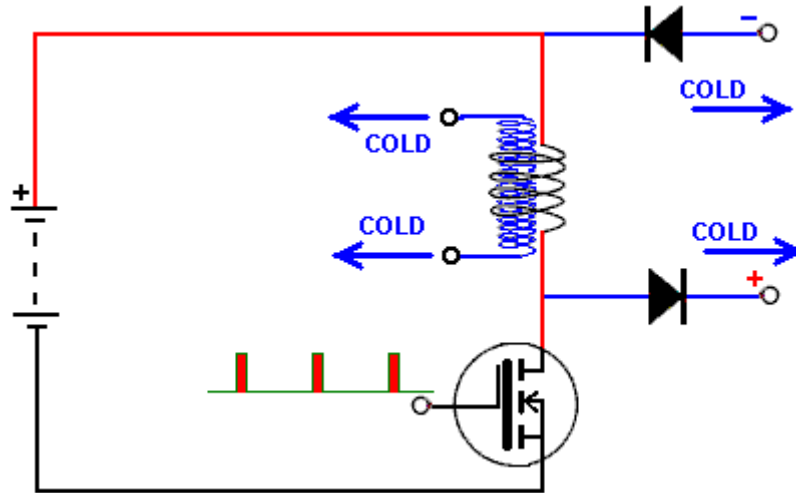

This provides two separate, independent cold electricity power outputs. Diodes are not needed for the inner 'secondary' coil. This inner coil is a pick-up coil and is not related in any way to the number of turns in the hot electricity pulsing coil. Instead, this coil collects inflowing cold electricity during the period when the pulsing coil is switched OFF. The hot electricity pulsing coil can be wound directly on top of the extra pick-up coil or the extra coil can be wound separately and placed inside the main coil spool.

Very surprisingly, it is recommended that the powerful high-speed diode used to channel the cold electricity out of the circuit, be followed by a small 1N4148 silicon epitaxial planar high-speed diode (75V 0.45A) as this is said to clean up the cold electricity output even more. It is important that the cold electricity has to encounter the more powerful silicon diodes before reaching the 1N4148 diodes, so the order of the diodes is very important, and should be as shown here:

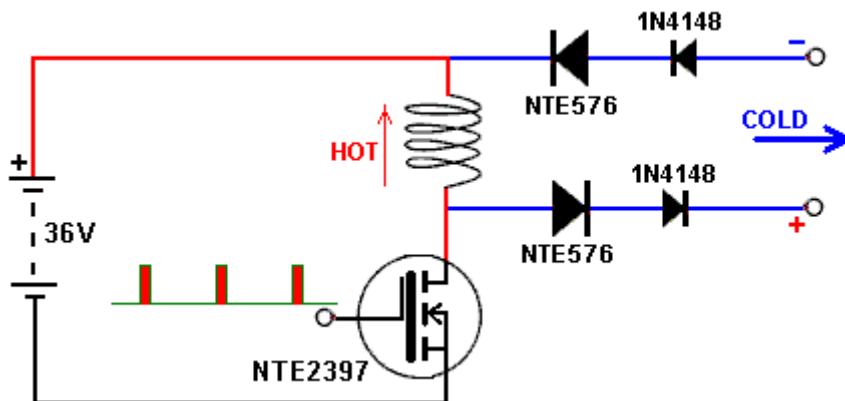

Alternative diodes for the NTE576 (6A, 35nS, 400V) are the NTE577 (5A, 70nS, 1000V) and the HFA16PB (16A, 19nS, 600V). The main requirement is high-speed operation, voltage rating of at least 400V and current rating of at least 5 amps..

There is one additional thing to be done with this circuit when a DC output is required and that is to apply filtering to the output. First, when the energy has passed through the NTE576 (or equivalent) power diodes, it encounters a high-frequency (low capacity) high quality film capacitor placed across the output in order to siphon off any high-frequency voltage ripple before it is passed through the small 1N4148 diodes and into a smoothing and storage electrolytic capacitor. Storing the cold electricity in the electrolytic capacitor converts it into conventional hot electricity.

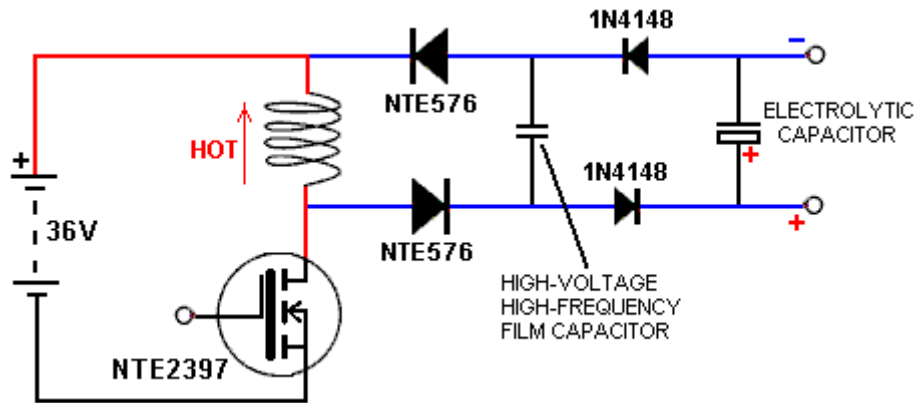

While this circuit looks like something which you just switch on and it works, that is not the case as there is an essential start-up procedure where the signal applied to the transistor is started at just a few cycles per second and 50% duty cycle and that input is then adjusted carefully and slowly while monitoring the voltages and currents produced by the circuit. This is a seriously powerful system with the capability of producing a major power output.

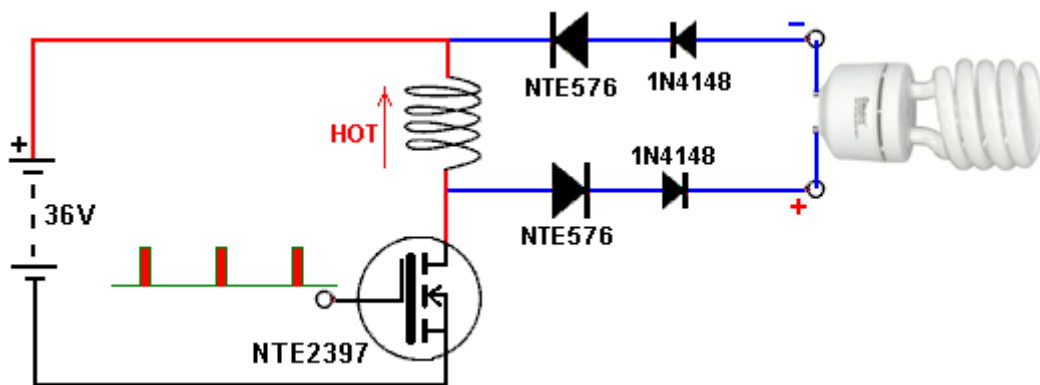

It is very important that the circuit is not powered up without a suitable load on the cold electricity output. A suitable load is a self-ballasted 230-volt fluorescent light. It must be understood that just flipping the power switch to it's ON position is not sufficient to get an inflow of cold electricity. Instead, it is necessary to progress the start-up sequence carefully, and a fluorescent light is particularly helpful for doing this although a neon bulb is also a popular choice of temporary load, because these devices allow the current flow in the load to be assessed visually.

Before switch-on, the input oscillator is set to 50% duty cycle and minimum frequency. Then the frequency is raised very slowly, causing the lamp to start flashing. As the frequency is raised, the current drawn from the battery needs to be monitored as it is the current flowing through the transistor, and the current is kept down by lowering the duty cycle progressively. This process is continued carefully and if successful, the colour of the light produced will initially be purple or green before reaching continuous bright white light. Videos showing the light produced and the fact that it is not dangerous to life or affected by water can be seen at <http://www.youtube.com/watch?v=W1KALMgFscg&list=UUdmFG5BeS0YnD2b5zasXXng&index=1&feature=plcp> .

The driving force is a series of powerful magnetic pulses, and implementing the physical circuit to achieve that requires careful construction. The battery driving the circuit is a 36 volt combination of cells. The coil is wound as an air-core construction on a 2-inch (50 mm) diameter spool and the DC resistance is arranged to be about 1.4 or 1.5 ohms. This, in turn, requires a substantial drive from the transistor and so it is normal to connect six powerful output transistors in parallel in order to spread the current flow between them as well as dissipating the heat generated across several transistors bolted to a common heat-sink of generous area.

How the coil is wound is something to consider. The objective is to have a coil of about 1.5 ohm resistance and which has the maximum magnetic effect for the current passed through it. Copper wire has become very expensive and so it would be very costly to wind the coil with vast lengths of thick wire, not to mention the very large size and great weight which would be produced by doing that. The copper wire options in Europe are typically to work with half-kilogram reels of wire. The details of some of these are as follows:

Gauge (swg)	Wire length	Total ohms	Amps/strand	Strands	Total amps
14	17.5 m	0.09	9.3	None	-
16	27 m	0.22	5.9	None	-
18	48 m	0.71	3.7	None	-
20	85 m	2.23	1.8	2	3.6
22	140 m	6.07	1.2	4	4.8
24	225 m	15.81	0.73	11	8.0
26	340 m	35.70	0.45	24	11.0
28	500 m	77.50	0.29	52	15.0

We can see from this that a 500 gram reel of 14 swg wire has a total resistance of just 0.09 ohms and so it would take sixteen reels (weighing 8 kilograms and costing a lot of money) to wind just a one-strand coil using that wire, producing a coil which could carry a current of 9.3 amps. As opposed to that, a single reel of 28 swg could provide 52 separate windings, which when connected in parallel, could carry 15 amps as well as costing and weighing far less. It would be tedious, but not impossible, to wind a 52-strand coil, so a more reasonable number of strands connected in parallel might be used. We are aiming at a DC resistance of about 1.45 ohms in any coil arrangement which we select.

The magnetic field produced by a single strand is generally less than the magnetic field produced by two strands carrying the same total current. So, if we were to pick 22 swg wire, then we could measure out four 33.5 metre lengths, join them at the start, and wind the four strands simultaneously, side-by-side to form a coil with a DC resistance of 1.45 ohms. It is important that the strands are exactly the same length so that they carry exactly the same current and no one strand gets overloaded with current due to it having a lower resistance than the other strands. It should be realised that as the maximum current which the wire can carry is 4.8 amps and the resistance is only 1.45 ohms, the maximum continuous DC voltage which can be sustained by the coil is only 7 volts, and so as a 36-volt battery is being used, we **must** adjust the frequency and duty cycle very carefully, especially since we are starting at very low frequencies. If the full battery voltage is applied continuously to the coil, then the coil will be destroyed.

Various members of the forum have suggested, built and tested different circuits for feeding a variable-frequency variable-duty-cycle drive signal to the output transistor. However, 'UFOPolitics' recommends a simple 555 timer circuit. If you are not familiar with electronic circuits, then read chapter 12 which explains them in some detail, including the 555 timer family of circuits. The point stressed by 'UFOPolitics' is that the output taken from pin 3 of the 555 chip passes first through a 100 ohm resistor and then, every transistor gets a separate feed via a two resistor voltage divider pair. The 47K Gate-to-Ground resistor is to ensure that the FET turns off properly. It may be possible to increase the value of these resistors but they should never be less than 47K.

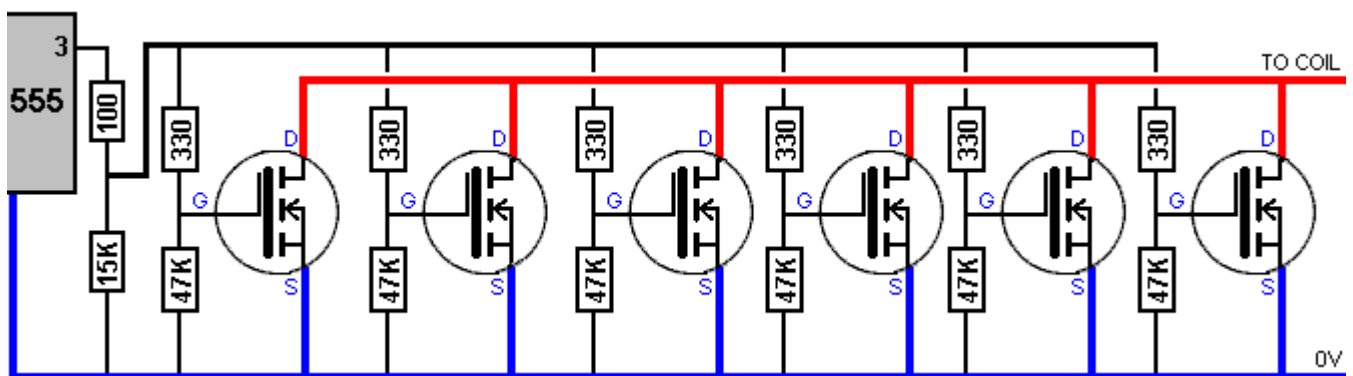

The thick lines in this diagram indicate heavy-duty wiring which can carry high currents without generating any real heat when doing so. It is also recommended that although the FET has an internal diode, an extra external high-speed diode (NTE576 or similar), be connected across each FET in order to boost the switching speed:

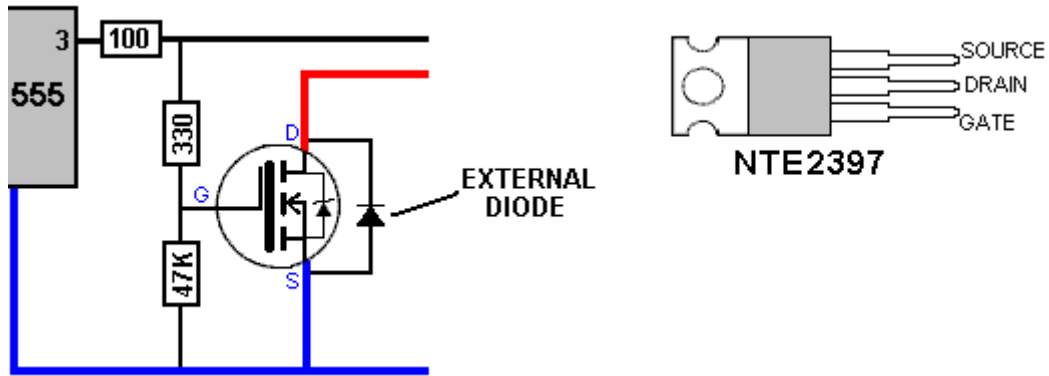

A FET has a gate capacitance of about 1 nF. The faster it can be charged / discharged the faster the FET will switch (and stay cool). What determines the speed of charge / discharge for the gate capacitance is the length of wire from driver to gate or gates is inductance (where one metre of wire produces 0.05 μ H). In addition to that, different lengths of Gate connection wire will create different switching delays and the different inductances can then initiate High Frequency oscillations with repetitive ON/OFF/ON/OFF switching actions. The result might be burned FETS and lack of cold electricity activities.

Another point made by 'UFOpolitics' is that the physical layout should have the connecting wires or tracks kept as short as possible and he suggests this layout:

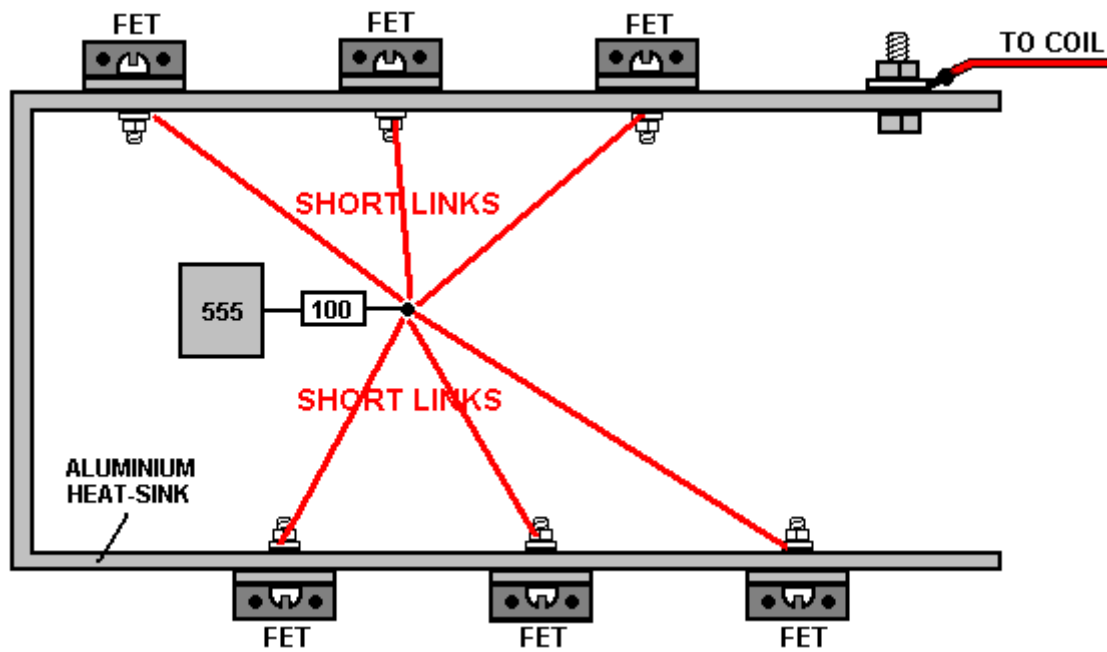

There are two things to note here. Firstly, the 100 ohm resistor coming from pin 3 of the 555 timer IC is positioned centrally between the six FET transistors mounted on the aluminium heat-sink, and that point is carried closer to each FET with a low-resistance conductor to give a good-quality link for the resistors feeding the Gate of each FET. Secondly, the heat-sink itself is also used to provide a low-resistance electrical connection to the coil which the FETs are driving. The connection to the heat-sink is via a nut and bolt clamping a solder tag firmly to a cleaned area of the heat-sink. Each FET is electrically connected to the heat sink through its mounting tag which forms its heat-sink connection as well as connecting to the Drain of the Transistor. However, if the aluminium heat sink is a black anodised type, then, apart from cleaning between each FET and the heat-sink contact area, it is worth running a thick wire also linking the central FET pins to the output wire connection point.

The transistors used in the prototype, and recommended for replications are the NTE2397. This is not a very common transistor in Europe at this time and so the popular IRF740 might perhaps be used as it appears to have all of the main characteristics of the NTE2397 transistor. 'UFOpolitics' suggests the 2SK2837 (500V, 20A, 80A pulsed), or the IRFP460 (500V, 0.27 Ohm, 20A and 80A pulsed).

As the 555 timer has a maximum supply voltage of 15 volts, an LM317N voltage-stabiliser chip is used to create a 12-volt supply from the 36-volt battery (a 24V battery could be used):

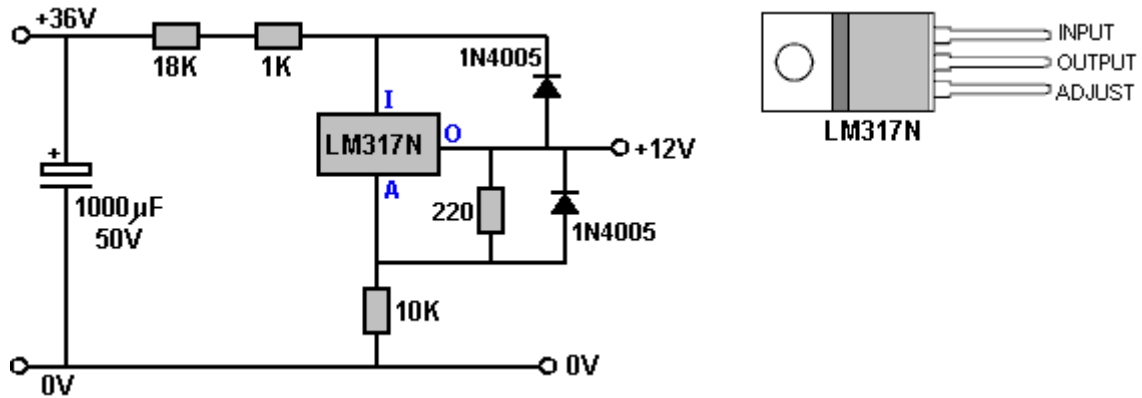

The LM317N integrated circuit should be attached to a good heat sink as it is dropping off 24 of the 36 volts powering the circuit, and so, has to dissipate twice the power that the NE555 chip uses:

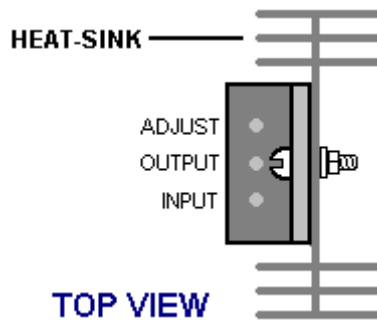

There are various pulsing circuits which have been used successfully with this system. 'UFOpolitics' considers the NE555 chip to be the most straightforward, so perhaps my suggestion for this arrangement might be a suitable choice:

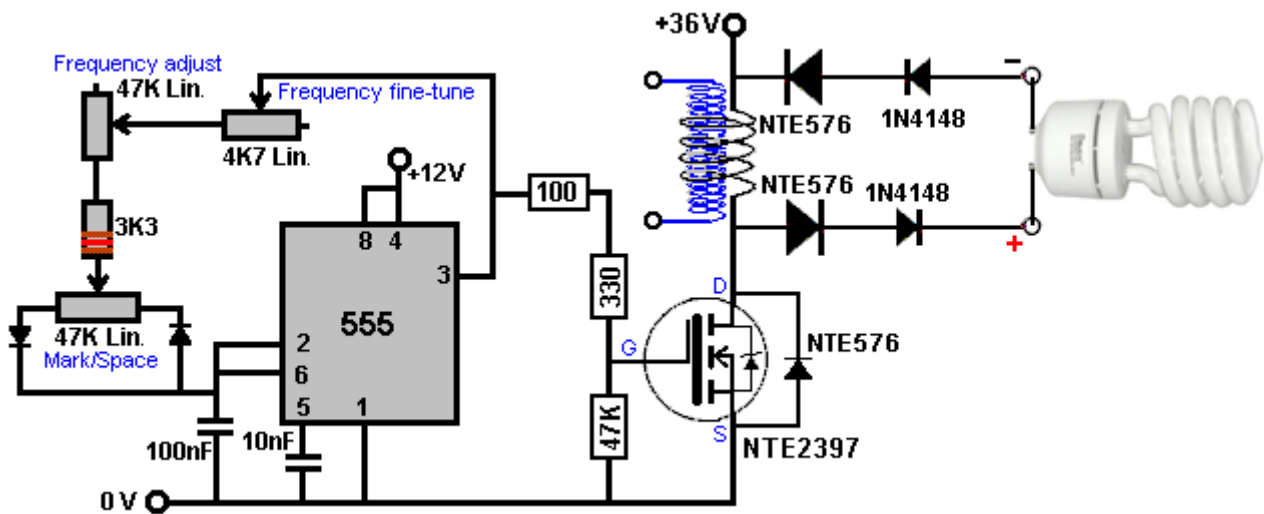

This gives fine control of the frequency and independent adjustment of the Mark/Space ratio or 'Duty Cycle' and it needs only three very cheap components other than the controls. If the expensive multi-turn high quality variable resistors are available, then the 4.7K 'fine-tune' variable resistor can be omitted as those variable resistors make the adjustments easier to control. The 'Lin.' in the diagram stands for 'Linear' which means that the resistance varies steadily at a constant rate as the shaft of the variable resistor is rotated.

In the 'UFOpolitics' circuit, it is important to turn the frequency down to it's minimum value and set the Mark/Space ratio to 50%, before powering the circuit up with a much higher frequency than is advisable and so, causing damage to some of the circuit components.

There are ways to boost the performance over what has already been described. One way is to insert a stainless steel core inside the coil. Stainless steel is supposed to be non-magnetic but in practice, that is not always the case. However, ideally, this steel core is improved by altering it's crystalline structure by heating it up and then quenching it by submerging it in cold water.

Another improvement is to isolate the coil better at switch-off through the use of a second transistor. Having a 'switched-off' transistor at each end of the coil certainly blocks the flow of hot electricity, but if Tom Bearden is correct, the resistance of the transistors in their OFF state will actually boost the flow of cold electricity as it reacts in the reverse way to how hot electricity reacts. The arrangement is like this:

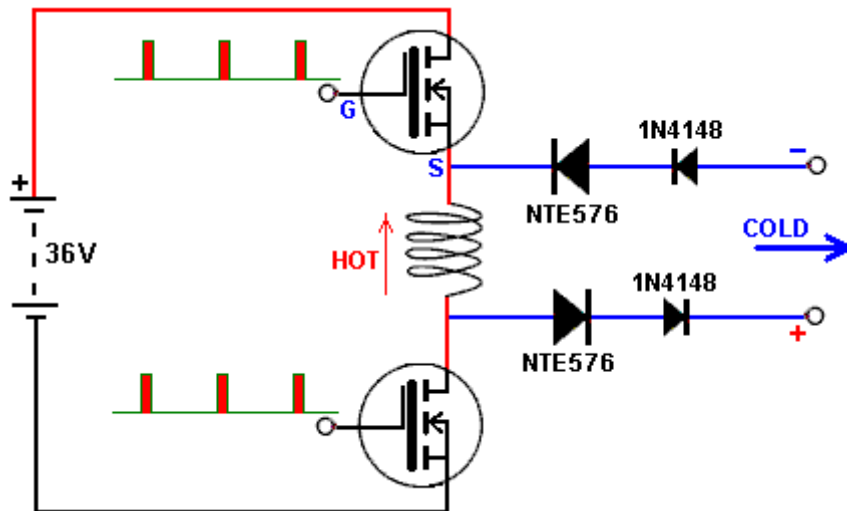

While this looks like a very simple circuit to implement, that is not the case. The upper transistor is switched ON by the voltage difference between it's Gate "G" and it's Source "S". But, the voltage at it's Source is not fixed but varies rapidly due to the changing current in the coil, and that does not help when solid and reliable switching of the upper transistor is needed. A P-channel FET could be used instead and that would have it's Source connected to the fixed voltage of the Plus of the 36V battery. That would help the switching enormously, but there would still be timing issues between the two transistors switching ON and OFF at exactly the same time. Other circuits have been suggested for doing that type of switching, but in the early stages, 'UFOpolitics' recommends that things be kept as simple as possible, so using just one transistor is the best option.

Switching speed is an item of major importance, even to the extent that the reduction in the speed of switching caused by using more than one transistor in parallel has caused the suggestion to be made that it might actually be a better option to use just one FET since these high-performance FETs are capable of carrying the whole of the switching current, and it is mainly to lower the FET operating temperature that multiple FET use is suggested. Every extra FET used in parallel, slows the switching down. However, it should be realised that there is a somewhat greater risk of burning the FET out if just one is used.

The coil dimensions recommended are two-inch (50 mm) diameter and 2-inch length. The wound coil is likely to be about three-inches (75 mm) so making the flange diameter 4-inches (100 mm) is realistic:

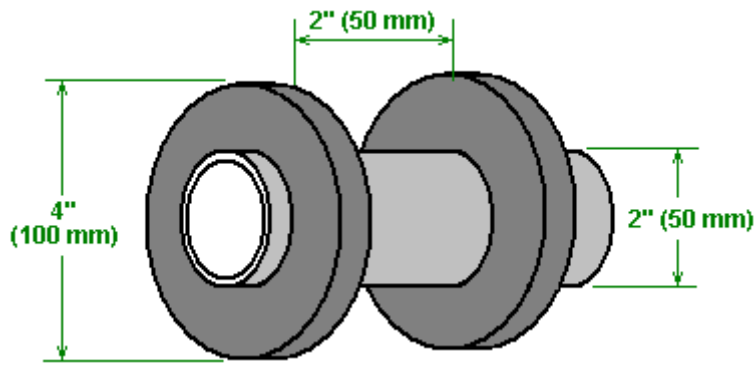

The recommended material is fibreglass which has high heat-resisting properties as well as being easy to work, the personal choice of 'UFOpolitics' is Polyester Resin with Methyl Ethyl Kethol (MEK) Hardener. A suggested alternative is acrylic, which is not as heat resistant. Acrylic is excellent for high-frequency applications but this circuitry does not operate at high frequencies. Whatever spool material is chosen, it needs to be non-magnetic. When connected in the circuit, the start of the coil winding wire goes to the battery positive.

Here is another coil wound on acrylic tube and with all four diodes connected to the ends of the coil:



It should be understood that cold electricity provides almost unlimited power and it has uses which are not readily understood by many people.

'UFOpolitics' suggests that the hot electricity drive circuitry be tested initially using just a resistive load. If everything checks out correctly, then test with a lesser value resistor in series with the coil, and if that checks out satisfactorily, then testing cautiously with the coil on it's own.

Cold electricity can charge batteries rapidly and after a series of charge and discharge cycles, batteries become 'conditioned' to cold electricity and the experiences of Electrodynne Corp. staff show that large conditioned batteries which are fully discharged, can be recharged in under one minute. A member of the present forum has tried this with the 'UFOpolitics' circuit and he reports:

Yesterday a friend and I took 6 identical, old, 12V, 115Ah batteries and made two 36V banks. We set up bank "A" (the better three) to power the device to charge bank "B". Bank A was 37.00v at rest and Bank B was 34.94V.

My lowest frequency was 133Hz (I need to change my cap and add another 100k pot with the one which is controlling the frequency) and the duty cycle was at 13%. We started at 2A draw on the Primary circuit.

As I raised the frequency, the batteries on charge jumped up to 38.4V then dropped evenly to 36.27V and started up again (at about 0.01V every 2 seconds). After two and a half hours, they were up to 39.94V. At this point we stopped the charging and let everything rest for 10 minutes. So far everything seems very normal for this kind of charging, except that the device appears to be very stable and powerful...pushing the batteries right on up continuously. The Primary battery voltage dropped initially to 36.20V and stayed there the whole time, then recovered to 36.98V during the 10 minute rest.

Then we switched battery banks A and B and charged the opposite way for about 20 minutes. We stopped and rested things again, swapped the banks back and started charging bank B again for another 20 minutes and stopped. After letting the batteries rest for a few hours in order to get truer readings, bank A was at 37.07V and bank B was at 38.32V. Both battery banks had gained power. These were not very good batteries, either. One of the bank B batteries was at 10.69V at the start. Another interesting note: The amp draw on the Primary dropped from 2A to 1.5A as the frequency was raised from 133Hz to about 550Hz.

This was with the very first use of cold electricity with these low-grade batteries and a major improvement can be expected after many additional charge/discharge cycles. This completely overcomes the factors which make a battery bank unsuitable for household power. If an entire battery bank can be recharged in just minutes, then it opens the way for serious household power using a battery bank.

Cold electricity can also run motors very powerfully. Forum member 'Netica' found that putting a capacitor across the motor terminals improved the running very substantially, giving impressive performance. His video of this is at http://www.youtube.com/watch?feature=player_detailpage&v=7uAYKhrPDPc and the motor, running off an air-core coil with no steel insert. His set-up looks like this:

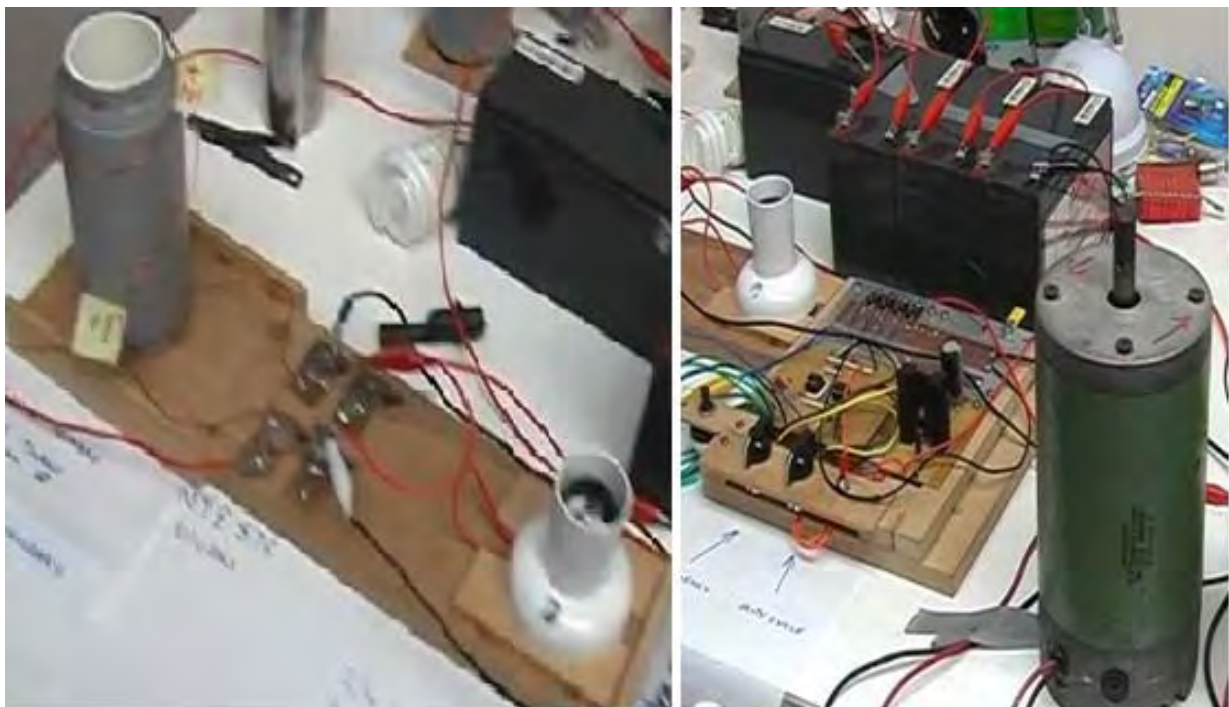

It is also possible to submerge cold electricity circuits in water without causing any harm:



A video of this is located here: <http://www.youtube.com/watch?v=W1KALMgFscg&feature=channel&list=UL> including demonstrating the use of very powerful light bulbs. A general running demonstration is here: http://www.youtube.com/watch?v=yVzhKpEqUgc&feature=player_embedded .

Stanley Meyer's Electrical Particle Generator.

Stan, who is famous for his water-splitting and related automotive achievements, actually held about forty patents on a wide range of inventions. Here is one of his patents which circulates magnetic particles in a fluid, and while the fluid does move, none of the other components in the device move and a high level of constructional skills is not called for. This is a highly efficient generator of electricity.

This is a slightly re-worded excerpt from this Stan Meyer patent. Although it does not state it in the patent, Stan appears to make it understood that this system produces a significant power gain – something with Patent Offices find very difficult to accept.

Patent CA 1,213,671

4th February 1983

Inventor: Stanley A. Meyer

ELECTRICAL PARTICLE GENERATOR

ABSTRACT

An electrical particle generator comprising a non-magnetic pipe in a closed loop having a substantial amount of magnetised particles encapsulated inside it. A magnetic accelerator assembly is positioned on the pipe, which has an inductive primary winding and a low-voltage input to the winding. A secondary winding is positioned on the pipe opposite to the primary winding. Upon voltage being applied to the primary winding, the magnetised particles are passed through the magnetic accelerator assembly with increased velocity. These accelerated particles passing through the pipe, induce an electrical voltage/current potential as they pass through the secondary winding. The increased secondary voltage is utilised in an amplifier arrangement.

BACKGROUND AND PRIOR ART

The prior art teachings expound the fundamental principle that a magnetic field passing through inductive windings will generate a voltage/current or enhance the voltage across it if the winding is a secondary winding.

It is also taught by the prior art, that a magnetic element in a primary inductive field will be attracted at one end of the coil and repelled at the other end. That is, a moving magnetic element will be accelerated in motion by the attraction and repulsion of the magnetic field of the primary inductive winding.

In the conventional step-up transfer, the voltage across the secondary is a function of the number of turns in the secondary relative to the number of turns in the primary winding. Other factors are the diameter of the wire and whether the core is air or a magnetic material.

SUMMARY OF THE INVENTION

The present invention utilises the basic principle of the particle accelerator and the principle of inducing a voltage in a secondary winding by passing a magnetic element through it.

The structure comprises a primary voltage inductive winding having a magnetic core, plus a low-voltage input. There is a secondary winding with a greater number of turns than the turns in the primary winding, plus an output for using the voltage induced in that winding.

The primary winding and core are positioned on one side of an endless, closed-loop, non-magnetic pipe. The secondary windings are positioned on the opposite side of the endless pipe. The pipe is filled with discrete magnetic particles, preferably of a gas, and each particle has a magnetic polarised charge placed on it.

Due to their magnetic polarisation charges, the particles will sustain some motion. As the particles approach the accelerator assembly, which is the primary coil, the magnetic field generated by the coil attracts the particles and accelerates them through the coil. As each particles passes through the coil, the repulsion end of the coil boosts the particle on it's way. This causes each particle to exit from the coil with an increased velocity.

As the magnetic particles pass through the secondary coil winding, they induce a voltage across the ends of that coil. Due to the larger number of turns, this induced voltage is much higher than the voltage across the primary coil.

The main objective of this invention is to provide an electrical generator which is capable of producing a voltage/current of much greater magnitude than has been possible previously. Another objective is to provide a generator which uses magnetic particles and a magnetic accelerator. Another object is to provide a generator which can control the amplitude of the output. Another objective is to provide a generator which can be used with DC, AC, pulsed or other configurations of waveforms. Another objective is to provide a generator which can be used in either a single-phase or a 3-phase electrical system. Another objective is to provide a generator for developing magnetised particles for use in an electrical particle generator. Another objective is to provide an electrical generator which uses readily available components to construct a simple embodiment of this invention.

BRIEF DESCRIPTION OF THE DRAWINGS

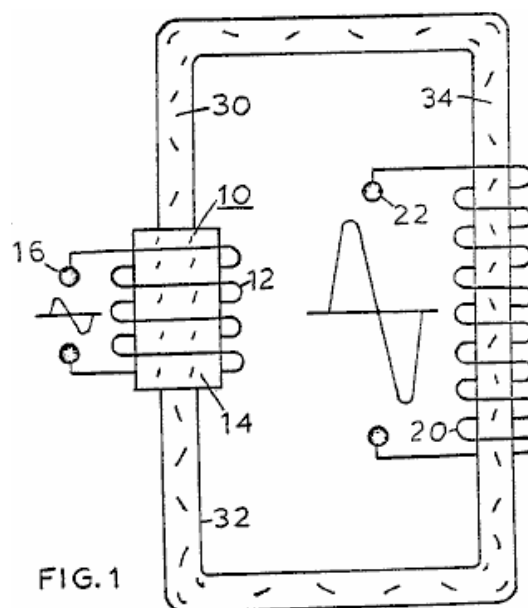

Fig.1 is a simplified illustration of the principles of the invention, shown partially in cross-section and partially pictorially.

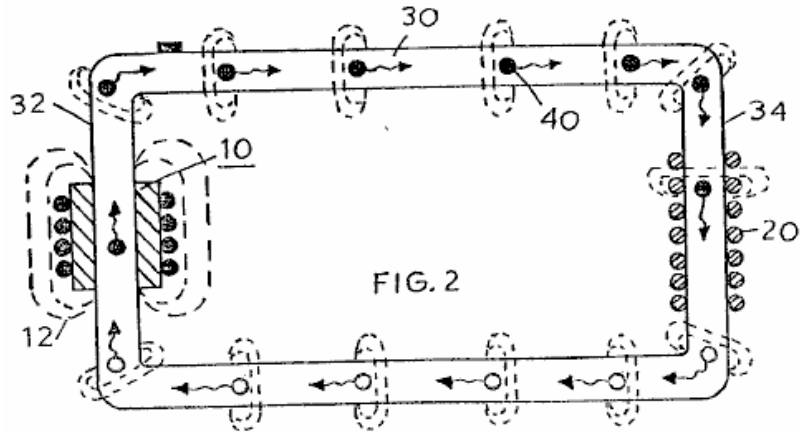

Fig.2 is an electrical schematic illustration of the embodiment shown in **Fig.1**.

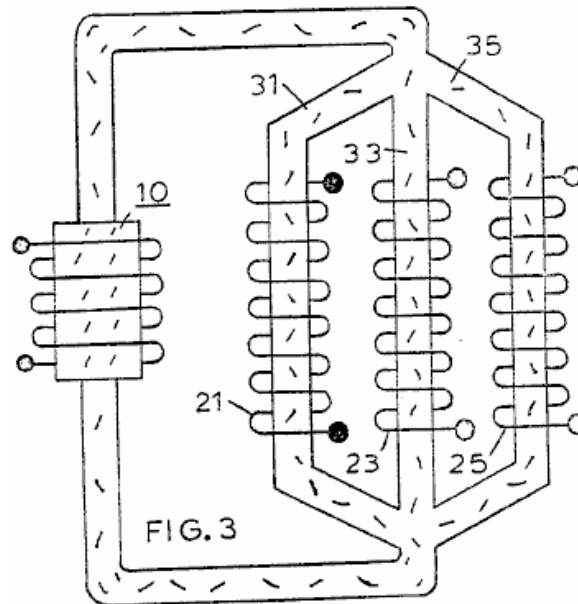

Fig.3 is an illustration similar to **Fig.2** but which is adaptable to 3-phase use.

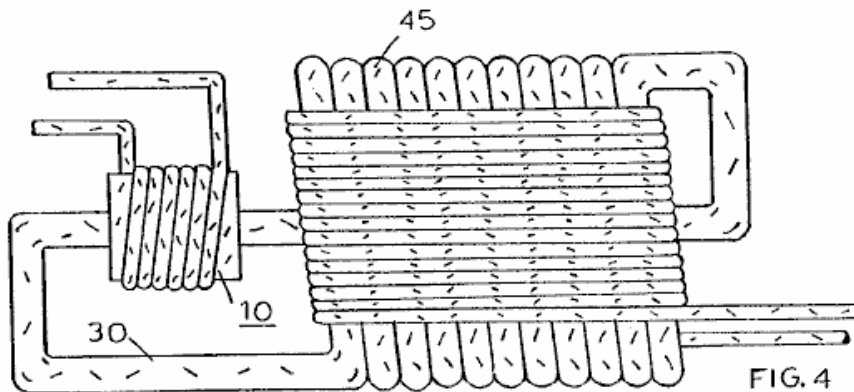

Fig.4 is a first alternative arrangement of a preferred implementation of the invention.

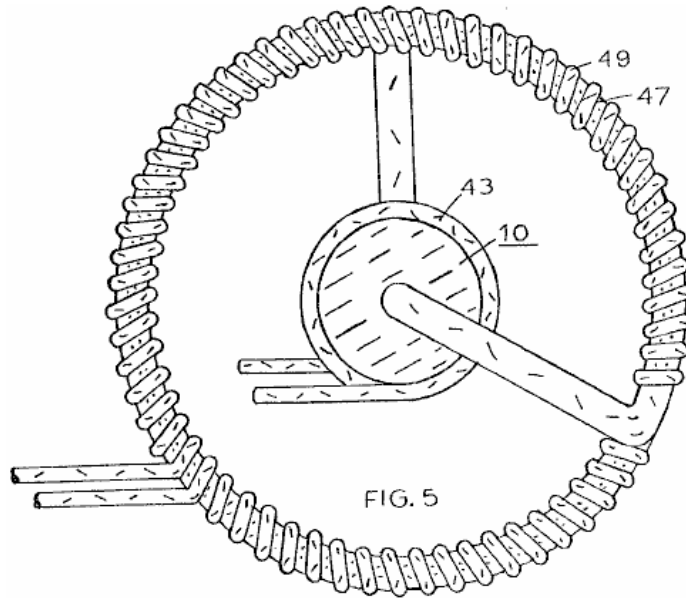

Fig.5 is another alternative arrangement of a preferred embodiment of the invention.

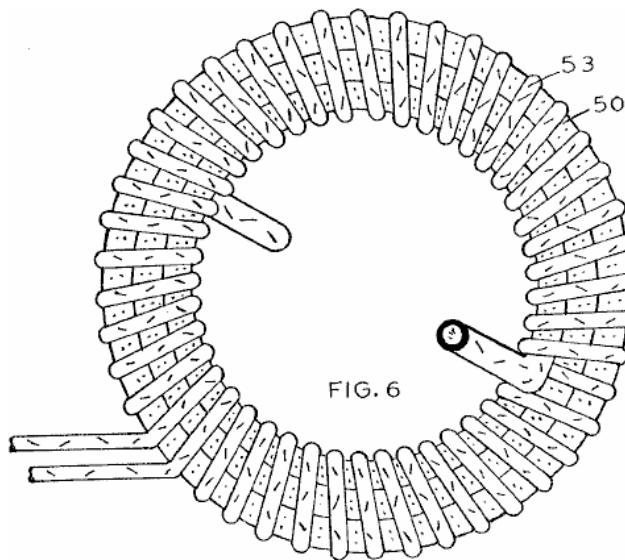

Fig.6 is another alternative arrangement of a preferred embodiment of this invention.

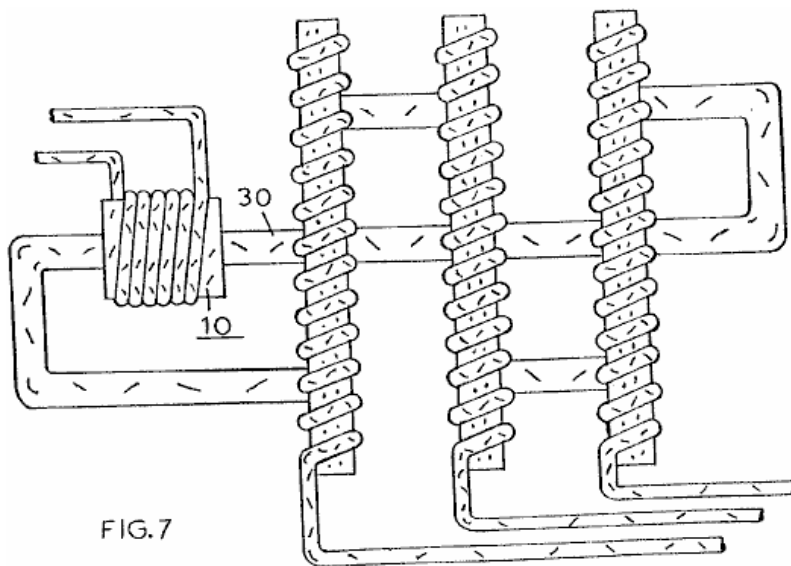

FIG.7

Fig.7 is another alternative arrangement of a preferred embodiment of this invention.

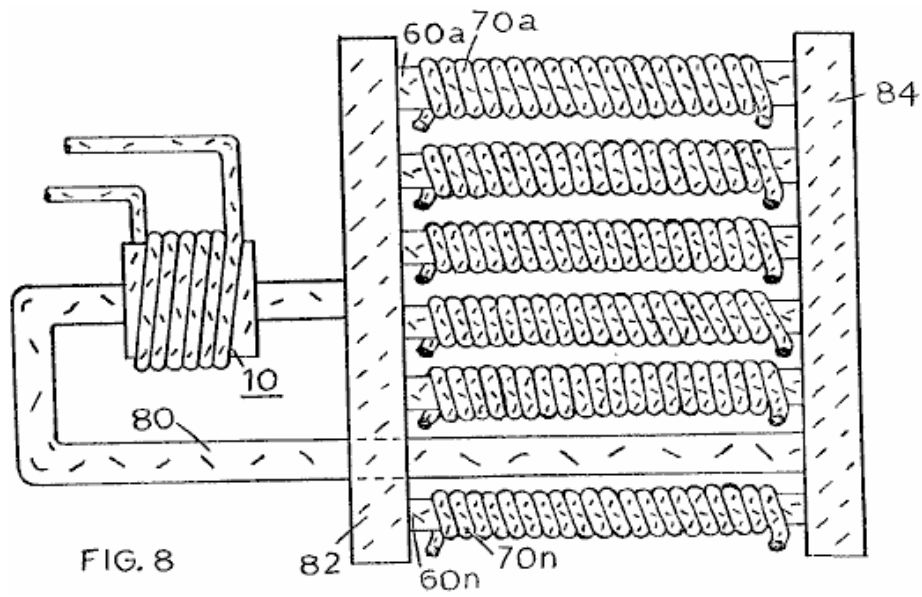

Fig.8 is another alternative arrangement of a preferred embodiment of this invention.

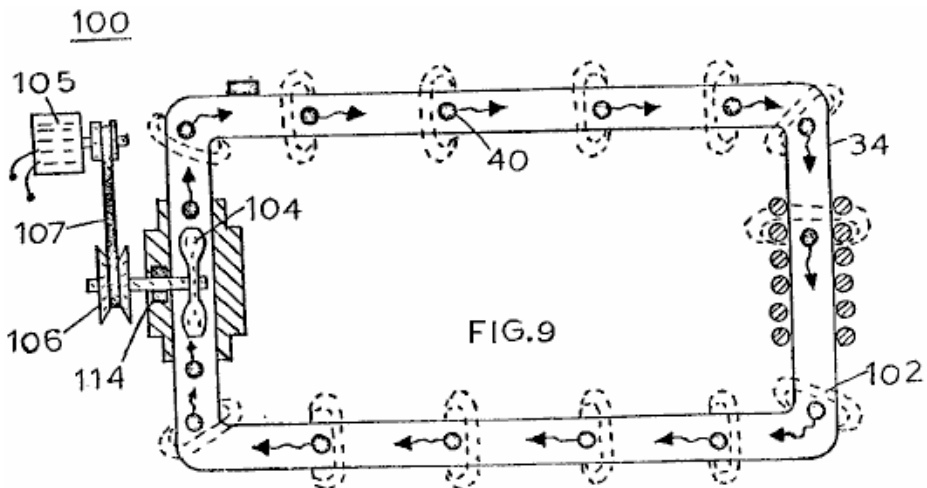

Fig.9 is an alternative arrangement for a magnetic drive particle accelerator assembly.

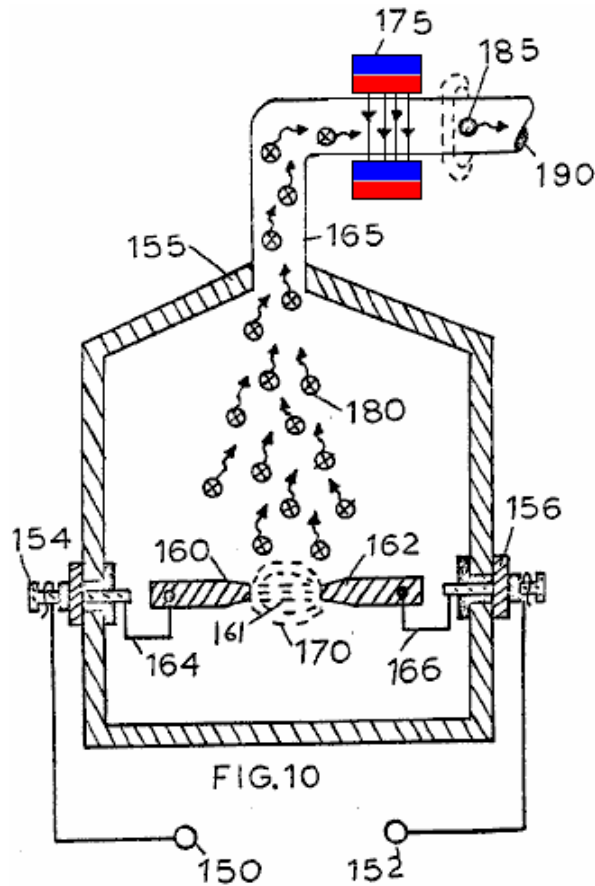
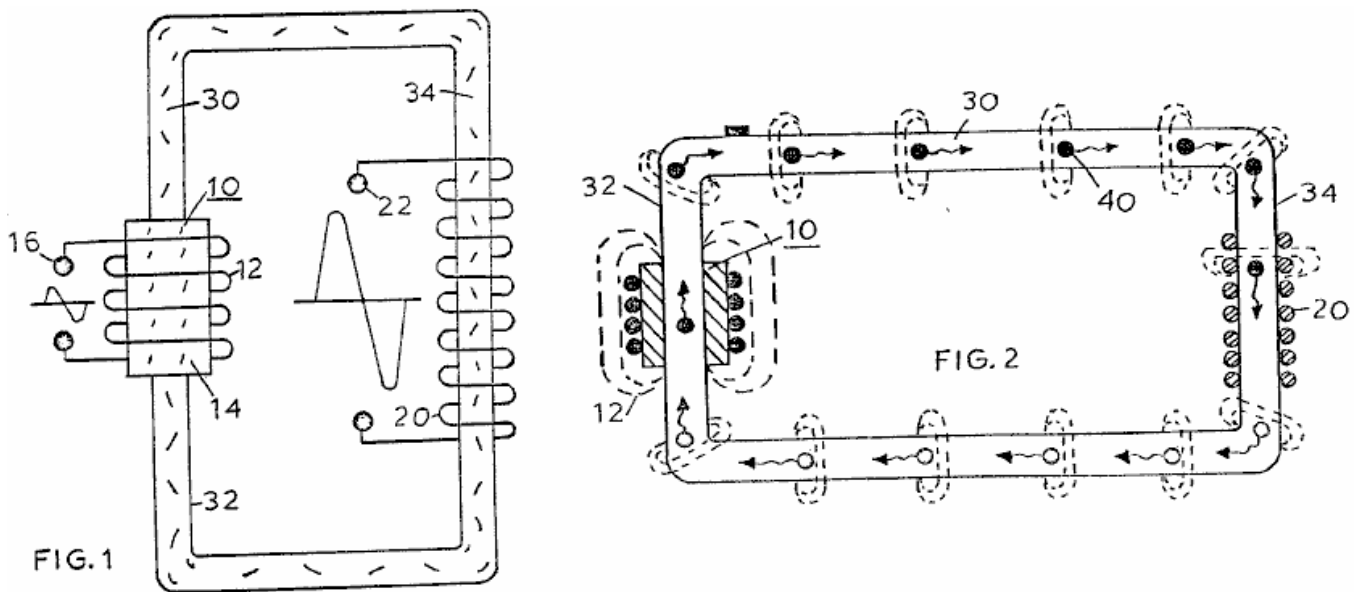

FIG.10 is an illustration of an alternative method of producing the magnetised particles used in this invention.

DETAILED DESCRIPTION

Fig.1 and Fig.2 show the invention in it's most simplified schematic form:



It comprises a primary coil magnetic accelerator assembly 10, a closed-loop non-magnetic pipe 30, and a secondary winding 20. The magnetic accelerator assembly is comprised of primary windings 12, a magnetic core 14, and voltage taps 16. The primary windings are positioned around end 32 of the closed-loop pipe 30 which is made from non-magnetic tubing.

At the opposite end **34** of the closed-loop pipe **30**, are the secondary windings **20**. The end terminals **22** of the secondary winding **20**, allow the voltage generated in the winding to be used. Contained inside pipe **30**, there is a substantial number of magnetic particles **40** as shown in **Fig.2**. The particles **40** must be light enough to be freely mobile and so may be particles suspended in a fluid medium such as gas, liquid or light-weight movable solid particles. Of these options, the use of a gas is preferred. If solid particles are used as the transporting medium, then it may be desirable to remove all air from inside the pipe in order to reduce the resistance to the flowing particles. Each of the particles **40** is magnetised and the following description refers to one individual particle and not to the mass of particles as a whole.

The voltage applied to terminals **16** of primary winding **12**, is a low voltage, and it's magnitude may be used as an input signal control. By varying the input voltage, the accelerator will vary the speed of the circulating particles, which will, in turn, vary the magnitude of the voltage/current output of the secondary winding **20**. The output **22** of the secondary transformer winding **20**, is a high voltage/current output.

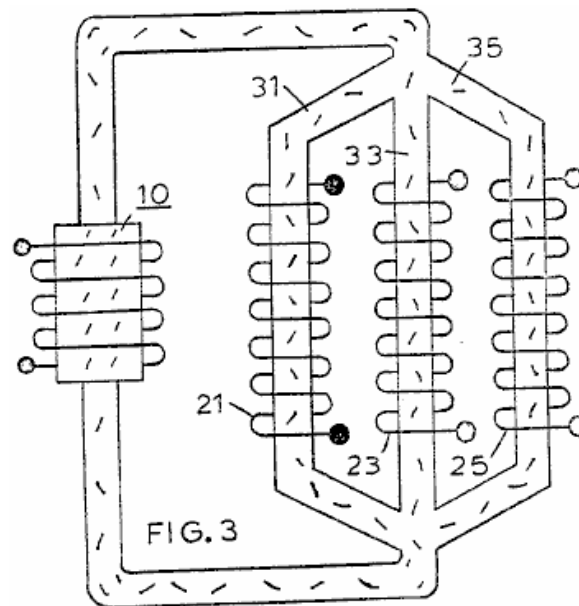

It can be appreciated that the system shown in **Fig.1** and **Fig.2** where there is just one closed loop, provides a single-phase output in the secondary winding **20**. **Fig.3** shows a closed-loop arrangement with three parallel non-magnetic tubes **31**, **33** and **35**, each with it's own output winding **21**, **23** and **25**. Each of these three windings are a single-phase output, and as their three pipes share a common input junction and a common output junction, these three output windings provide a balanced 3-phase electrical system.

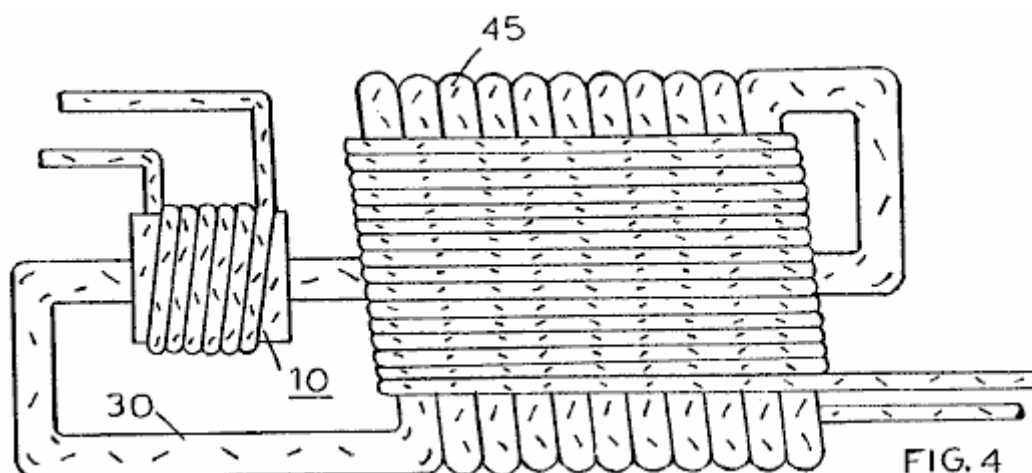

Fig.4 shows an electrical power generator which operates exactly the same as those shown in **Fig.1** and **Fig.2**. Here, the arrangement is for use in an environment where there is a high moisture content. An insulating coating **45**, completely covers pipe **30** as well as all of the electrical windings. **Fig.4** also illustrates the fact that increasing the number of turns for any given wire diameter increases the voltage/current output of the device. In this physical configuration, both vertical and horizontal directions are used which allows a large-diameter pipe to be used with a substantial number of turns of heavy-gauge high-current wire.

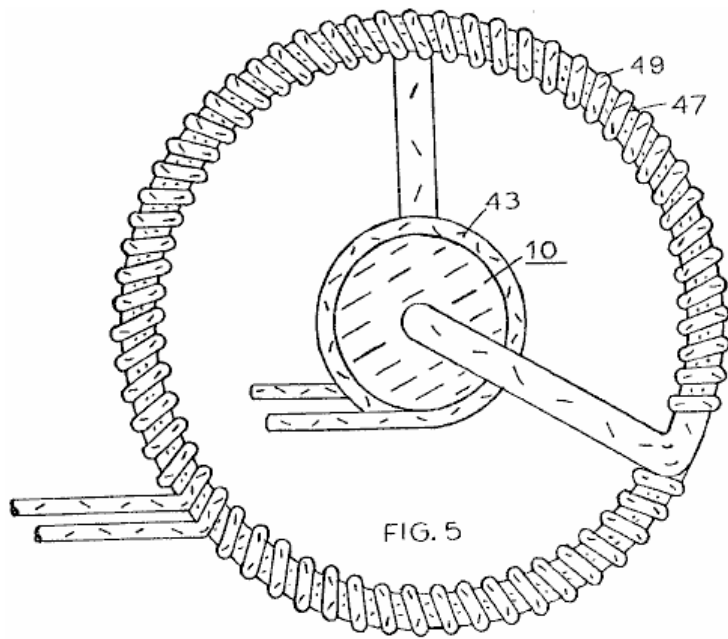

Fig.5 shows a coil arrangement 49, which uses the entire magnetic flux in the closed-loop tubing 47. This is a coaxial arrangement with the primary winding 43 as a central core.

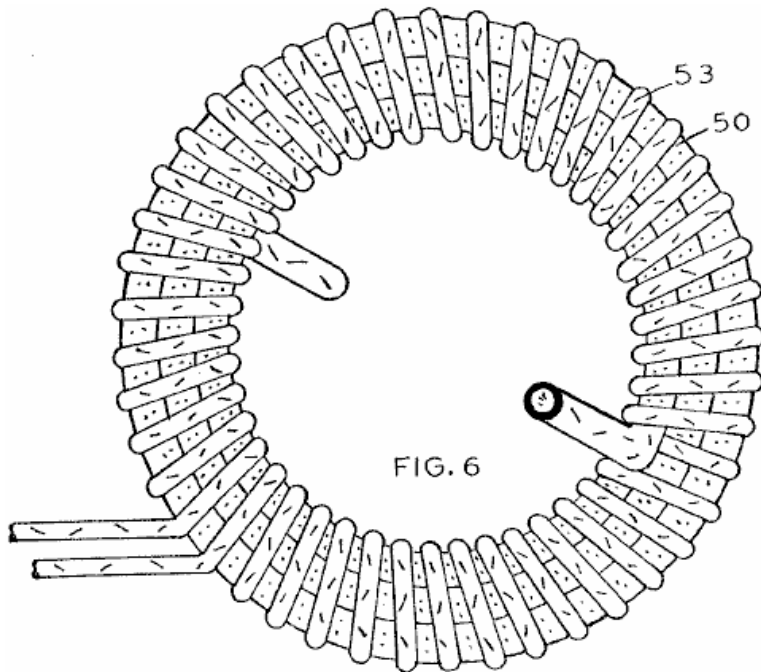

Fig.6 illustrates a concentric spiral configuration of the tubing 50, with the secondary windings 53 covering it completely.

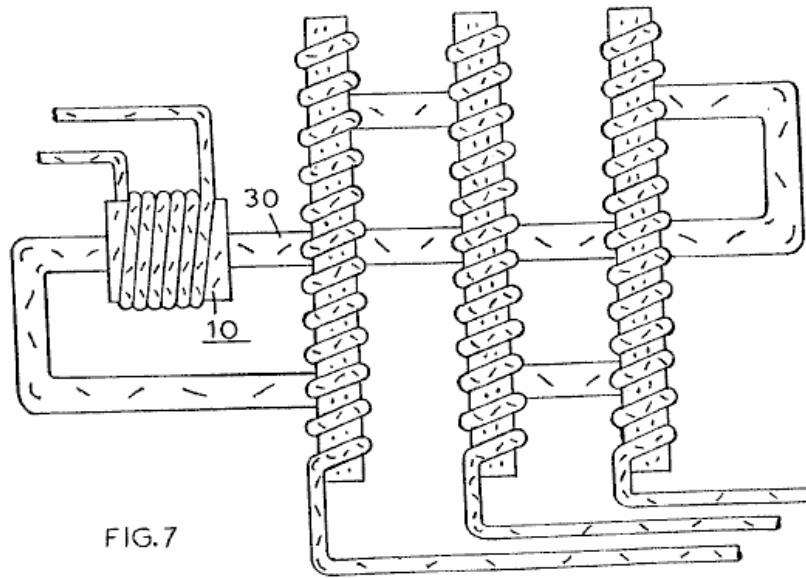

FIG. 7

Fig. 7 shows an arrangement where the particle accelerator **10** is wound over the tubing **30** in much the same way as in **Fig. 1** and **Fig. 2**. However, in this arrangement, the tubing **30** is a continuous closed loop arranged in a series-parallel configuration where there are three secondary windings providing three separate outputs while the tubing **30** runs in series through those three windings.

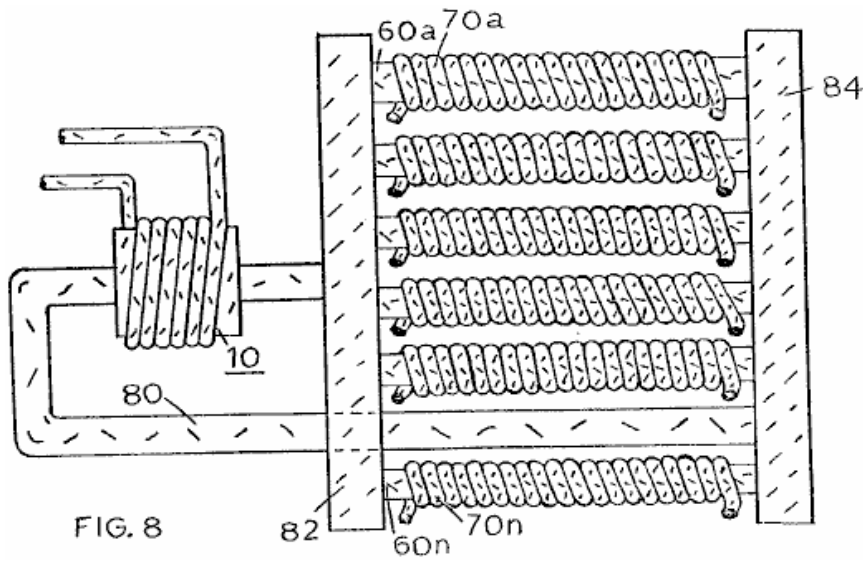
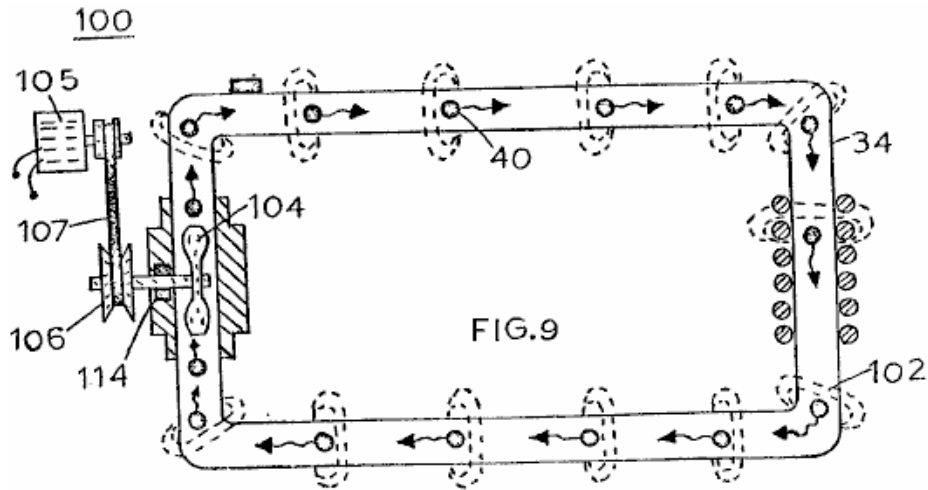

FIG. 8

Fig. 8 shows a configuration which is the reverse of that shown in **Fig. 7**. Here, there are several pick-up coils wound in series and unlike the earlier configurations, the tubing **80** is not continuous. In this arrangement, there is an input manifold **82**, and an output manifold **84**, and several separate tubes **60a**, **60b**, **60c**, **60n** interconnecting those two manifolds. Each of those separate tubes has its own separate secondary coil **70a**, **70b**, **70c**, **70n** wound on it.



The magnetic particle accelerator **10**, can be different in design to that shown in **Fig.1**. **Fig.9** shows a mechanical particle accelerator **100**. In this arrangement, the magnetic particles **102** are permanently magnetised prior to being encapsulated in the non-magnetic pipe **110**. The particles **102** are accelerated by fan blade or pump **104** rotated by mechanical drive assembly **106**. The mechanical drive for assembly **106** may be a belt-drive pulley **112**, or similar device driven by an electric motor. A sealing bearing **114** keeps the particles **102** inside the pipe **110**.

It has been stated that the magnetic particles traversing the secondary coils, generate a voltage/current in them. It must be understood, however, that that the particles are actually traversing the magnetic field of those coils.

Also, the pipe **30** has been described as a non-magnetic pipe. There are certain non-magnetic pipes which would not work with this invention. Pipe **30** must be capable of passing magnetic lines of force.

A significant feature of each of the various embodiments already described, is the generation of the magnetic particles which are encapsulated within the tubing.

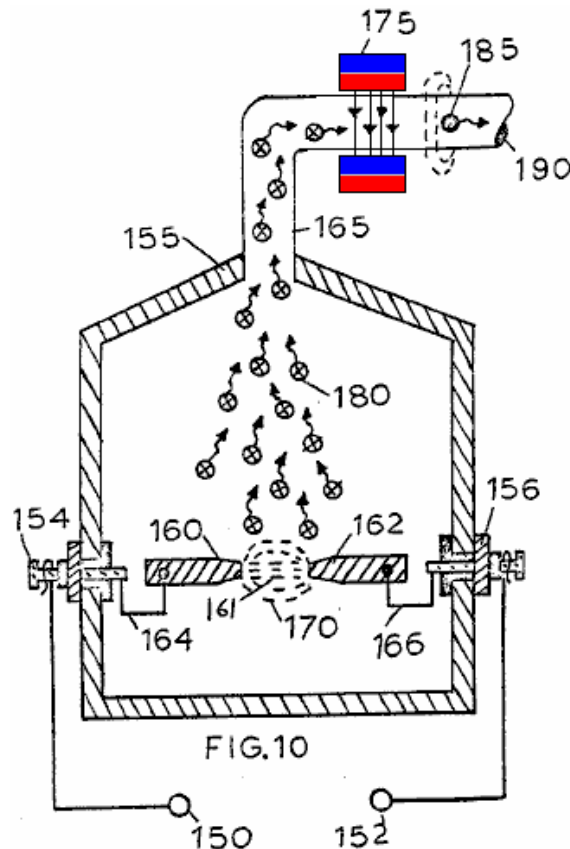

Fig.10 shows an apparatus for carrying out the process of vaporising material to produce suitable particles which are then magnetised by being subjected to a magnetic field. The chamber **155** is an evacuated chamber having

electrodes, made from magnetisable metal, **160** and **162**. A voltage is applied between terminals **150** and **152**, and this drives a current through terminals **154** and **156**, to spark-gap electrodes **160** and **162**, generating an arc which vaporises the tip material of the electrodes, producing particles **180**. These particles rise and enter tube **190**, passing through a magnetic field generator **175**. This gives each particle a magnetic charge and they continue on their way as magnetically-charged particles **185**, passing through port **190** to reach the electrical particle generator described above.

In the simplified embodiment shown in **Fig.1** and **Fig.2**, as well as the other preferred embodiments mentioned, it was indicated that a low voltage was applied to the particle accelerator **10**. Upon acceleration, a high voltage/current would be induced in the secondary pick-up coil **20**. A most significant advantage of the present invention is that the voltage amplification is not related to the shape of the waveform of the input voltage. Specifically, if the input is DC a DC voltage will be output. An AC input will produce an AC output. A pulsed voltage input will produce a pulsed voltage output and an input voltage of any other configuration will produce an output having that same configuration.

The Work of Russ Gries.

Russ Gries has produced a video presentation and analysis of the above Stan Meyer patent. <http://www.youtube.com/watch?v=OnAmTmxBpAQ>.

The very experienced Alex Petty is joining with Russ in working on replicating Stan's system and Alex's web site is at www.alexpetty.com. A discussion forum linked to this is at <http://open-source-energy.org/forum/> and there is information at <http://www.overunity.com/index.php?topic=5805.285> and high-resolution pictures can also be seen in Russ' video at <http://www.youtube.com/watch?v=JOarpi6sDD4>. Russ' own website is at <http://rwgresearch.com/> and an additional video of the most recent developmental work being undertaken at: <http://www.youtube.com/watch?v=adzVQRsS1KY&feature=youtu.be>.

There are various important things which are commented on and Russ is to be commended for drawing attention to them. For the moment, please forget about HHO as that is a separate issue. As far as I can see, the patent does not claim that the device is COP>1 but instead that the device is a power transformer which potentially has a greater power output than conventional transformers since there is no Lenz Law reverse magnetic path from the output coil winding to affect the input power.

Having said that, Stan in his video points out ways to boost the power of the device, namely:

1. Increase the strength of the magnetic particles
2. Increase the speed of the magnetic particles
3. Lower the distance between the magnetic particles and the output winding.

The magnetic particles can be produced in various ways, but the most effective appears to be by filling the arcing chamber with argon gas and using iron, nickel or cobalt electrodes. The reason for this is that the electric arc does not only generate minute particles of the electrode material, but it also interacts with the argon, stripping off electrons and causing some of the metal particles to combine with the modified argon gas molecules to form a magnetic gas. That gas will always remain a magnetic gas due to the atomic bonding as it is not just minute particles of metal physically suspended in a gas due to their tiny size.

You will recall from chapter 1, that the very successful ShenHe Wang magnet motor/generator has a magnetic liquid as a key component. Here, Stan is producing a much lighter magnetic gas and the advantage of that lightness is that it can be boosted to very high speeds without any danger. The larger the number of modified argon molecules, the greater the magnetic effect when they pass through a coil of wire. The argon gas can be passed through the arc chamber over and over again so that a very high percentage of the gas is magnetic. Alternatively, if you are sophisticated in the design of the particle generator, you can arrange for the molecules which have become magnetic, to be pulled off into storage by a magnetic field.

Stan talks about pumping the magnetic gas through whatever pipe loop arrangement you decide to use, by a pump, but he promptly moves on to using a magnetic coil to boost the gas forward as the coil has no moving parts and so, no mechanical wear. This is only one reason. The main reason is that with magnetic acceleration, the gas speed can become very high indeed and in his video he talks about the speed of light. However, I personally do not believe that anything remotely like a speed that great could be achieved inside a pipe loop of small diameter. Nevertheless, speeds well in excess of what a mechanical pump can achieve are likely to be produced by magnetic acceleration.

Russ, in his discussion, points out that on most of Stan's surviving prototypes, the coil which is used for the acceleration is constructed using several apparently separate coils, and he speculates that each coil section is powered sequentially, causing a rippling magnetic field. While that is definitely possible, I don't see that a style of coil powering would have any advantage as opposed to powering all of the coils continuously. However, if sequential powering is believed to be an advantage, then the 'Divide-by-N' circuitry of chapter 12 can be used to provide the sequential powering or any more complex sequence.

Stan then points out that the output voltage can be increased by increasing the number of turns on the output coil and/or having additional output coils. This is easily understood conventional electrics. But, he then goes on to point out that the output will also be increased if the electrons of the modified argon molecules are raised to a high orbital level. This places the electromagnetic electrons (as described in chapter 11) closer to the output coils and presumably also allows the gas to be accelerated to a greater speed by the driving magnetic field.

This power boosting of the gas is achieved using Stan's "Gas Processor" described in chapter 10. The Gas Processor pumps electromagnetic energy into the gas through the use of banks of Light-Emitting Diodes which produce light of the correct wavelength to add energy to that particular gas.

If you check on the internet for the wavelength of argon, you find conflicting information, with some sites saying that the wavelength is 1090 nanometres ("nm") and most others saying both 488 nm and 514.5 nm. Most LEDs produce a band of frequencies, so it would be a case of picking LEDs whose band of frequencies include the wanted wavelength.

The Gas Processor itself, consists of a central tube which is polished to a mirror finish on the outside, surrounded by a larger tube which is highly polished on the inside. The LED light is then bounced between these polished surfaces until it is absorbed by the gas which is passed through the gap between the two tubes. This is not easy to illustrate, but it might be shown like this:

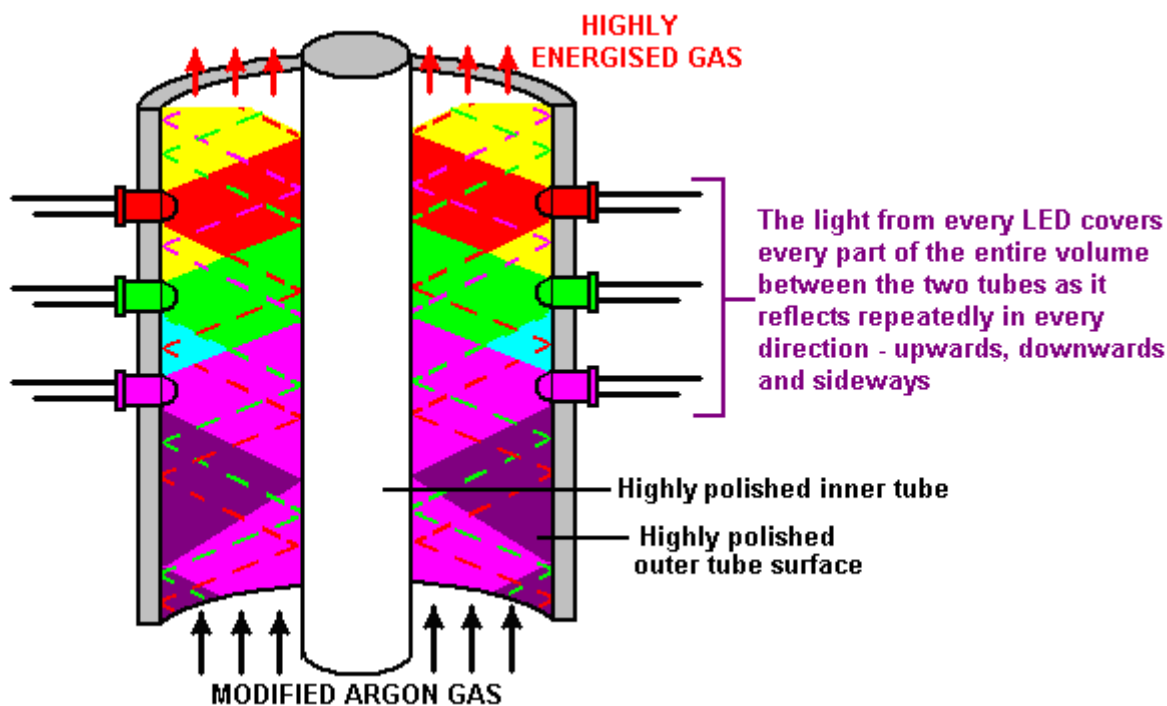

In Stan's design, he uses six columns of sixteen LEDs, with each column of LEDs spaced out evenly around the outer tube. So, to boost the Magnetic Particle Generator to greater power levels, a Gas Processor is placed in the loop of tubing:

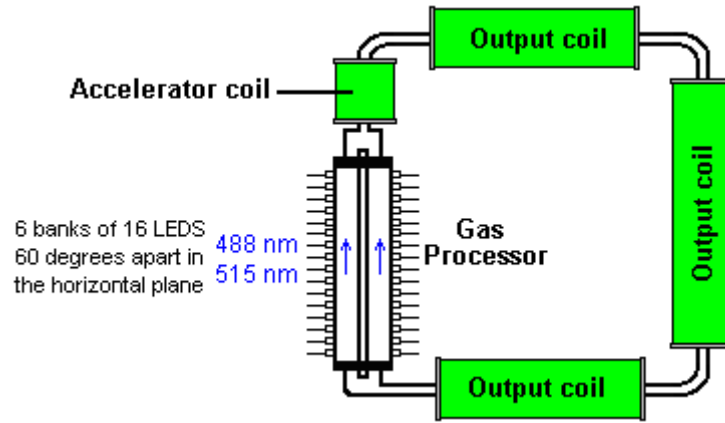

The Gas Processor normally has a coil mounted at each end and it may be convenient to use coils in those positions as accelerator coils. It may also be an advantage to apply a pulsed high-voltage between the inner and outer tubes of the Gas Processor. As it stands, this looks as if it has a high possibility of being a COP>1 electrical device.

Patrick Kelly

<http://www.free-energy-info.tuks.nl/>

Chapter 4: Gravity-Powered Systems

Lawrence Tseung's COP=3.4 Pulsed-Flywheel Generator.

It is generally not realised that excess energy can be obtained from pulsing a flywheel or other gravitational device.



This fact has recently been stressed by Lawrence Tseung who refers to the extra energy obtained in this way as being "Lead-out" energy. This gravitational feature has been part of university Engineering courses for decades, where it has been taught that the loading stress on a bridge caused by a load rolling across the bridge is far less than the stress caused if that same load were suddenly dropped on to the bridge.

This impulse technology has been known for some time and it is demonstrated driving a canoe in the video at <http://www.youtube.com/watch?v=XMhAldgHOCs> but Lawrence points out the potential for using it as a method for gaining excess energy for practical use. In October 2009, Lawrence and his band of helpers ran public demonstrations of an early prototype electrical pulsing system which produces excess output energy of COP = 3.3, that is, with 3.3 times more output energy than the user has to put into it to make it work:

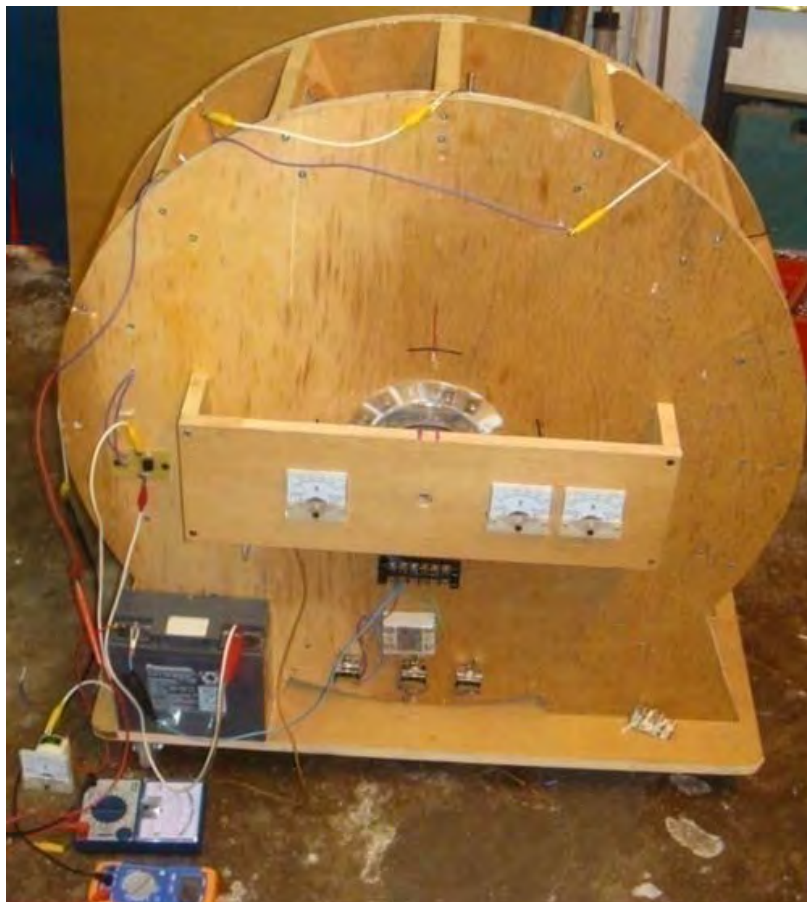

Video: http://www.youtube.com/watch?v=tiafQ9R-REs&feature=mfu_in_order&list=UL Lawrence is busy developing this device further as he intends to construct one with a output energy excess of several kilowatts.

Behind this device is Lawrence's "Lead-out" theory and for this he suggests a simple arrangement to demonstrate the principle. He presents the case of a rotor which has two substantial weights contained in two cylinders attached to the rotor:

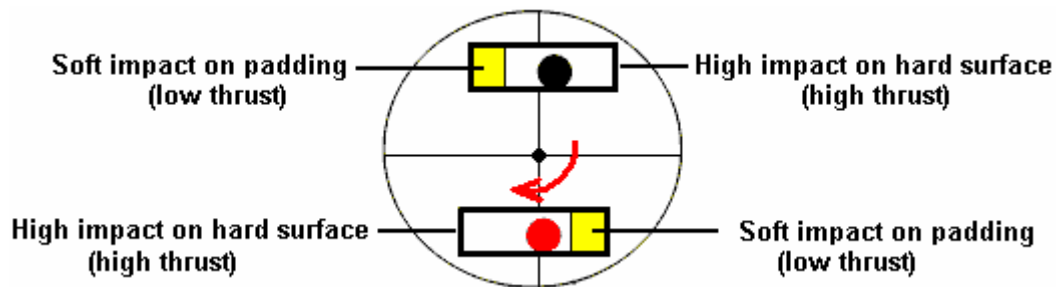

As the disc rotates, the ball falls down the length of the tube. At one end, the tube has a rigid cap which causes a significant impact when the ball hits it. The other end of the tube is padded and that cushions the impact which causes a net imbalance in the impacts and that maintains the rotation.

There is a prototype implementation on YouTube but the implementation is not adequate and the disc stops rotating after five minutes. The YouTube video slot is located at: <http://www.youtube.com/watch?v=zykButGc22U&feature=related> and there are two significant problems with that particular build. Firstly, the tube rotation is too slow to be effective and instead of the weight falling under gravity and accelerating to a good speed before the impact, the weight just rolls gently down a minor slope and does not make a major impact.

Secondly, the weights are far too small for the size of the wheel and there are only two weights providing impacts very widely spaced apart as the wheel rotates only slowly. One man made a ten-foot version and it rotated steadily for ten months after which time his wife insisted that it be taken apart as it was too noisy.

I would suggest some modifications to the wheel as Lawrence is far too busy with developing his COP>1 pulse implementation. Firstly, the movement of each weight should be delayed until the tube is much nearer the vertical. This can be achieved by curving part of the tube like this:

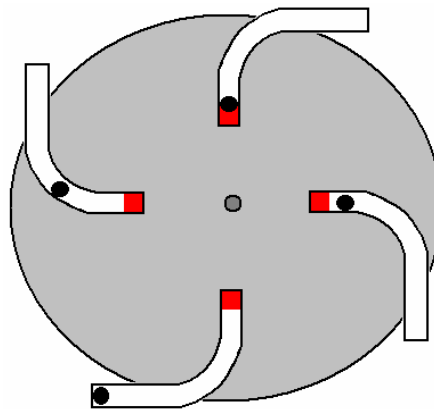

This way, the ball does not start rolling until the main part of the tube is near vertical. This allows a much greater acceleration and impact. The weighted ball should be much larger, say 2" (50 mm) in diameter and made of lead, in order to generate a significant thrust. Also, the cushioned ends of the tubes should be aligned with the pivot of the wheel so that any residual impact does not generate a turning force in the wrong direction. There is a negative turning effect due to the lever arm of the bottom weight. This turning force is only there for a small arc of rotation as the weight will roll inwards as soon as the tube section rises above the horizontal and as the tube then transitions into a circular curve, the movement inwards is gentle. It probably would be better if the tubes were angled slightly more in the clockwise direction, rather than exactly as shown in the diagram.

Secondly, there should be eight tubes on the disc, four on each side and one side staggered by 45 degrees so that there is a driving impact every 45 degrees instead of the 180 degrees of the version shown in the YouTube video. With that arrangement of four times as many impacts, each substantially greater, and no significant reverse impacts, the wheel has a much better chance of successful rotation without needing to be particularly large. The wheel itself should not be light as it acts as a flywheel and a pulsed flywheel has

already been shown to produce excess power. The wheel bearings should be ball races and not the closed variety because those ones are packed with grease and have a serious resistance to rotation. Instead, the open-sided variety of ball bearing should be used as they rotate very freely.

Using straight tubes for illustration, each tube could be like this:

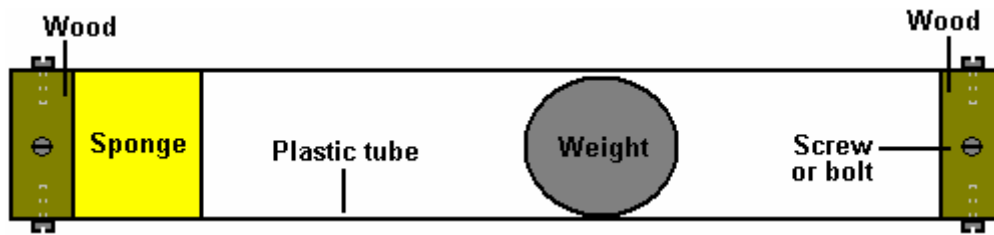

Here, a wood disc is fitted to each end of a piece of plastic tube and held securely in place with screws or bolts which pass through small holes drilled in the plastic pipe and screw into the wooden disc. A piece of thick sponge is glued to the disc at one end and the heavy weight inside the tube is not a tight fit so that it can move very freely inside the tube. Four of these tubes are fitted to each side of each disc used in the device as shown here:

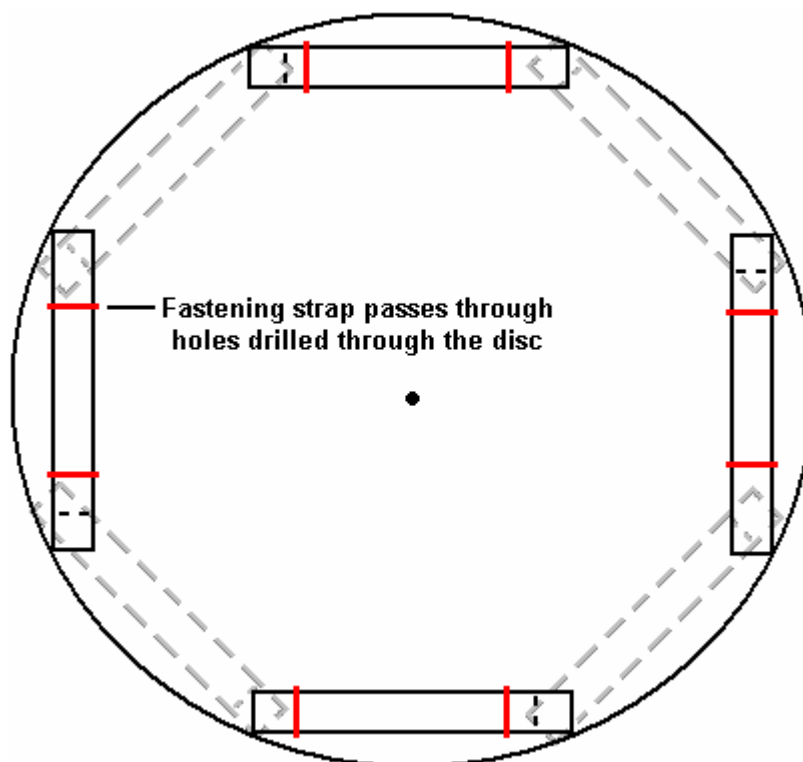

The four tubes attached to the back of the disc are 45 degrees away from the tubes mounted on the front of the disc. Each tube is attached securely in place with straps which pass through the disc and are secured on the far side. The tubes can also be glued in place to further strengthen the attachment. These eight tubes give an unbalanced impact for every 45 degrees of rotation. If two of these discs are attached to a common rotor shaft, then the second disc can be positioned 22.5 degrees around from the first one. That arrangement gives an unbalanced impact for every 22.5 degrees of rotation. If three discs were placed on a common rotor shaft and evenly positioned, then there would be an unbalanced impact every 15 degrees of rotation, which is 24 impacts per rotation. A two-disc arrangement might look like this:

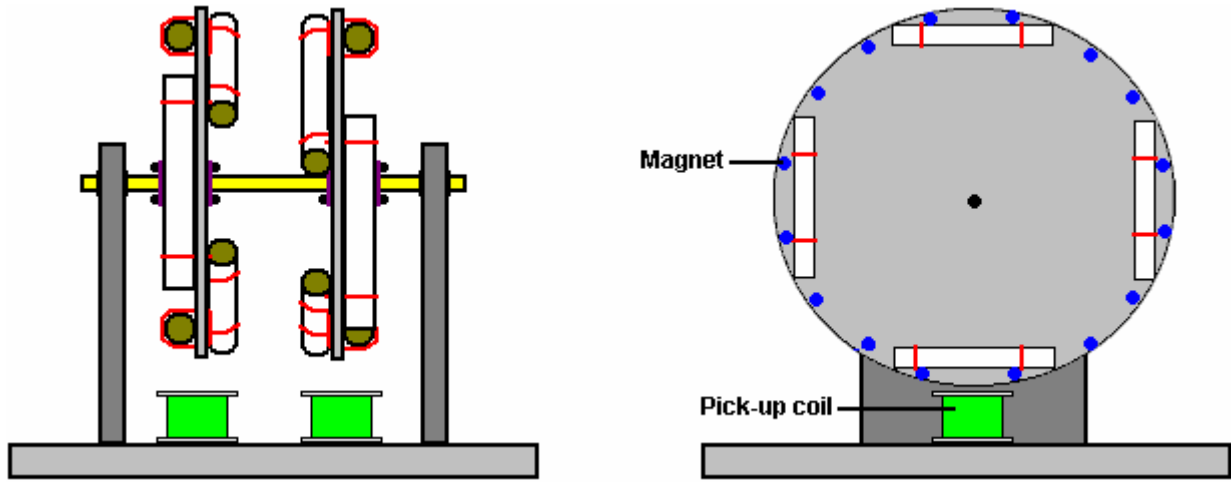

If the rotor spins well, then it would be worth while attaching a series of magnets to the discs, being careful to keep each disc perfectly balanced. One or more air-core coils can then be used to determine if current can be drawn from the device without stopping the rotation. The coils should not have a magnetic core as that would cause a major drag on the rotation whether current was being drawn or not.



Chas Campbell's Flywheel System.

Recently, Mr. Chas Campbell of Australia demonstrated electrical power gain with a flywheel system which he developed:

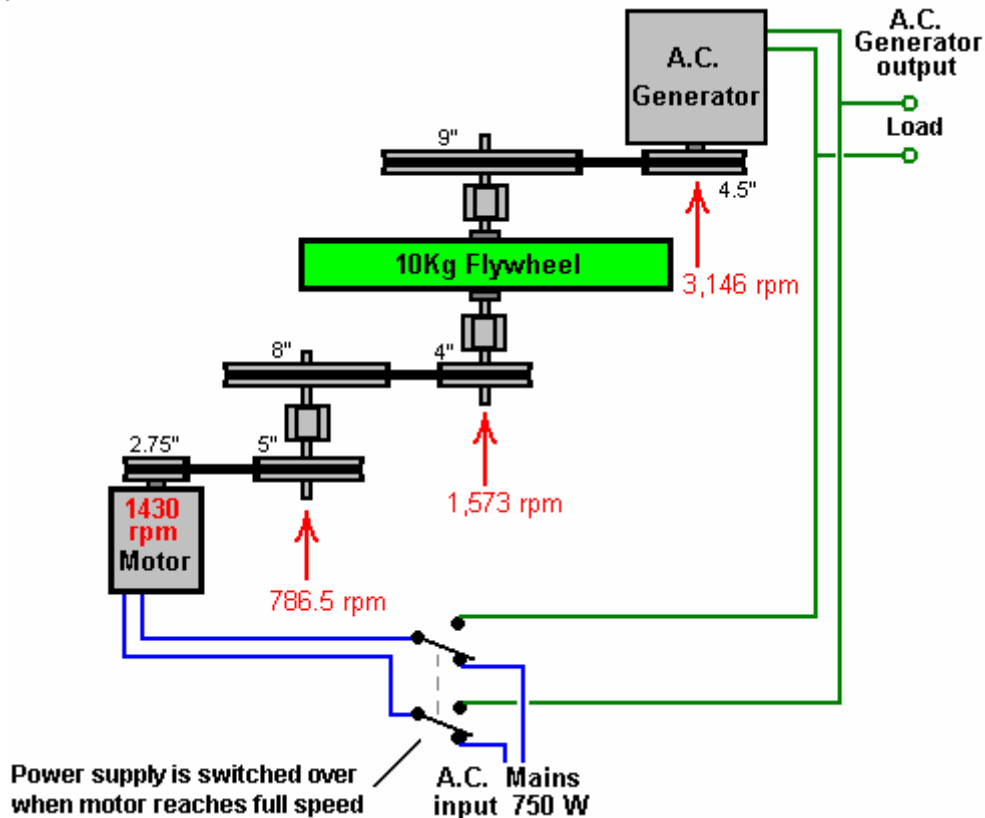

But what this diagram does not show, is that a couple of the drive belts are left with excessive slack. This causes a rapid series of jerks in the drive between the mains motor and the flywheel. These occur so rapidly that they do not appear noticeable when looking at the system operating. However, this stream of very short pulses in the drive chain, generates a considerable amount of excess energy drawn from the gravitational field. Chas has now confirmed the excess energy by getting the flywheel up to speed and then switching the drive motor input to the output generator. The result is a self-powered system capable of running extra loads.

Let me explain the overall system. A mains motor of 750 watt capacity (1 horsepower) is used to drive a series of belts and pulleys which form a gear-train which produces over twice the rotational speed at the shaft of an electrical generator. The intriguing thing about this system is that greater electrical power can be drawn from the output generator than appears to be drawn from the input drive to the motor. How can that be? Well, Mr Tseung's gravity theory explains that if a energy pulse is applied to a flywheel, then during the instant of that pulse, excess energy equal to $2mgr$ is fed into the flywheel, where "m" is the mass (weight) of the flywheel, "g" is the gravitational constant and "r" is the radius of the centre of mass of the flywheel, that is, the distance from the axle to the point at which the weight of the wheel appears to act. If all of the flywheel weight is at the rim of the wheel, the "r" would be the radius of the wheel itself.

This means that if the flywheel (which is red in the following photographs) is driven smoothly at constant speed, then there is no energy gain. However, if the drive is not smooth, then excess energy is drawn from the gravitational field. That energy increases as the diameter of the flywheel increases. It also increases as the weight of the flywheel increases. It also increases if the flywheel weight is concentrated as far out towards the rim of the flywheel as is possible. It also increases, the faster the impulses are applied to the system.

However, Jacob Bitsadze points out that another mechanism comes into play even if all of the belts are correctly tensioned. The effect is caused by the perpetual inward acceleration of the material of the flywheel due to the fact that it rotates in a fixed position. He refers to it as being 'the rule of shoulder of Archimedes' which is not something with which I am familiar. The important point is that Chas Campbell's system is self-powered and can power other equipment.

Now take a look at the construction which Chas has used:



You notice that not only does he have a heavy flywheel of a fair size, but that there are three or four other large diameter discs mounted where they also rotate at the intermediate speeds of rotation. While these discs may well not have been placed there as flywheels, nevertheless, they do act as flywheels, and each one of them will be contributing to the free-energy gain of the system as a whole.

If the drive motor were a DC motor which is deliberately pulsed by a special power supply, then the effect is likely to be even greater. Chas' system produces excess energy, and although it is by no means obvious to everybody, that excess energy is being drawn from gravity. At this time, one of the videos of Chas operating his device can be seen at: http://www.youtube.com/watch?v=8QD2Wwhs_LxA.

Ok, so what are the requirements for an effective system? Firstly, there needs to be a suitable flywheel with as large a diameter as is practical, say 4 feet or 1.2 metres. The vast majority of the weight needs to be close to the rim. The construction needs to be robust and secure as ideally, the rate of rotation will be high, and of course, the wheel needs to be exactly at right angles to the axle on which it rotates and exactly centred on the axle:

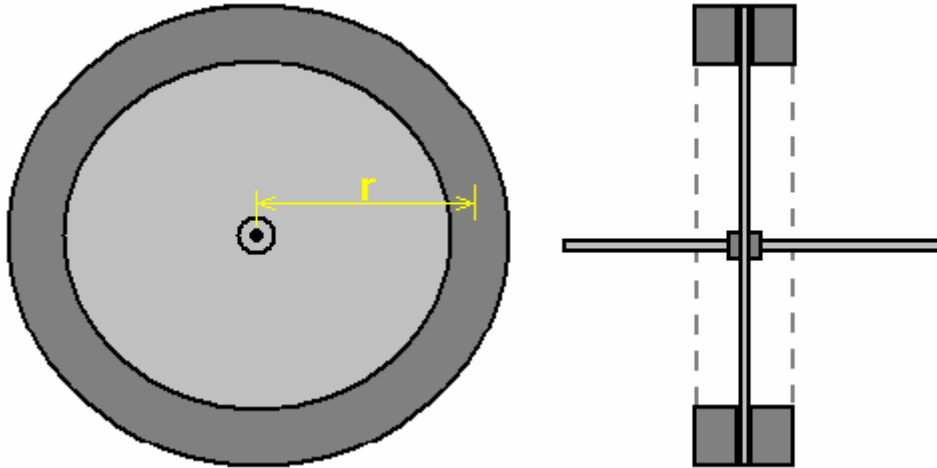

Next, you need a motor drive which gives a rapid pulsed drive to the shaft. This could be one of many different types. For example, the original motor design of Ben Teal where very simple mechanical contacts power simple solenoids which operate a conventional crankshaft with normal connecting rods:

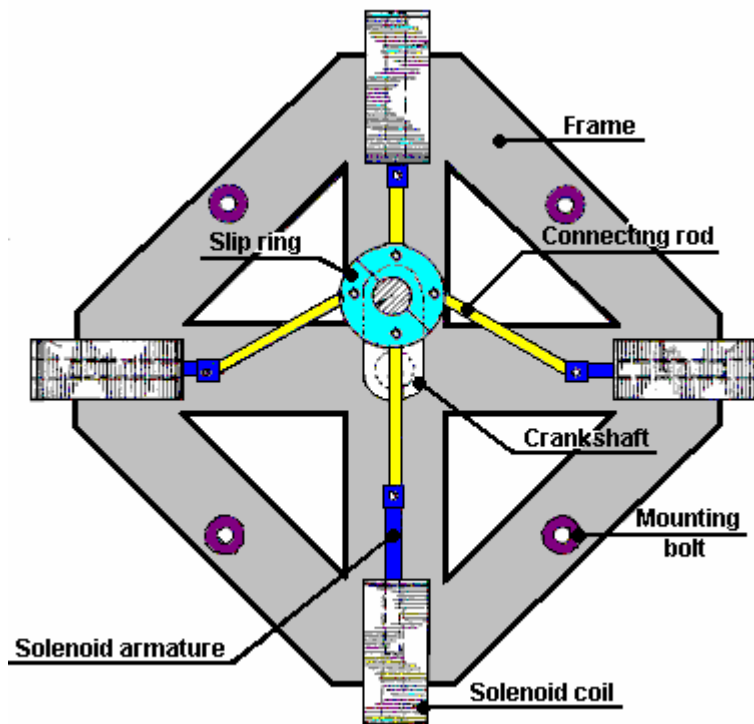

This style of motor is simple to construct and yet very powerful. The switch for each solenoid can be a very simple mechanical switch which is pushed closed by a cam when the crankshaft is in the position where the

solenoid should pull, and opens again when the crankshaft reaches the position where the solenoid should stop pulling. This motor also meets the requirement for rapidly repeated impulses to the axle of the flywheel. The motor power can be increased to any level necessary by stacking additional solenoid layers along the length of the crankshaft:

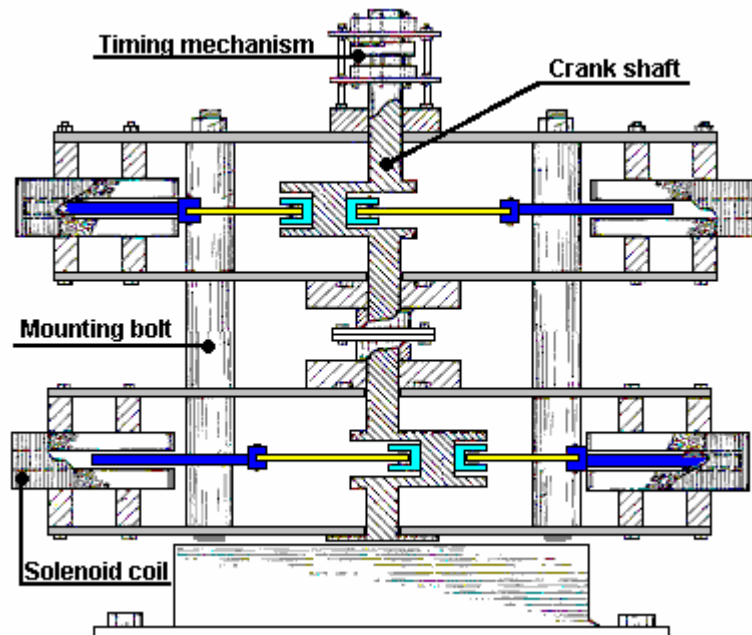

This style of motor looks very simple and its operation is indeed very simple, but it is surprising how powerful the resulting drive is, and it is a very definite contender for a serious free gravitic energy device in spite of its simplicity.

An alternative suitable drive system could be produced by using the same style of permanent magnet and electromagnet drive utilised by the Adams motor, where electromagnets positioned just clear of the edge of the rotor disc are pulsed to provide an impulse to the drive shaft, in the case shown below, every 30 degrees of shaft rotation.

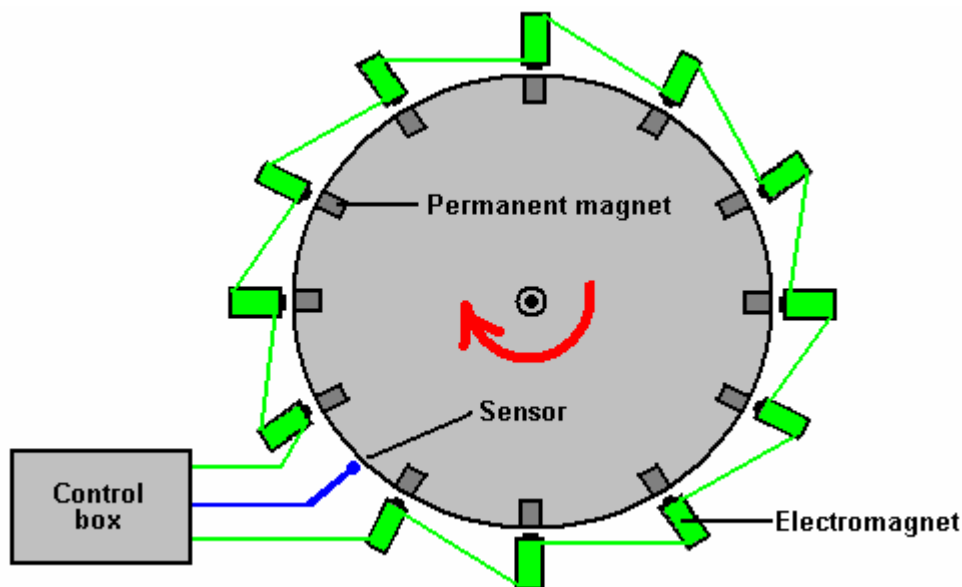

Here, the sensor generates a signal every time that one of the permanent magnets embedded in the rotor passes it. The control box circuitry allows adjustment of the time between the arrival of the sensor signal and the generation of a powerful drive pulse to the electromagnets, pushing the rotor onwards in its rotation. The control box can also provide control over the duration of the pulse as well, so that the operation can be fully controlled and tuned for optimum operation.

Any ordinary DC motor driven by a low-rate DC motor “speed controller” would also work in this situation, as it will generate a stream of impulses which are transmitted to the flywheel. The shaft of the flywheel will, of course, be coupled to an automotive alternator for generation of a low voltage output, or alternatively a mains voltage generator. It should be stressed that having several flywheels as part of the drive gearing, as Chas Campbell does, is a particularly efficient way of leading-out excess gravitational energy. Part of the electrical output can be used to provide a stabilised power supply to operate the drive for the flywheel.

It is possible to make the Chas Campbell arrangement into a more compact construction by reducing the size of the flywheel and introducing more than one flywheel into the design. It is perfectly possible to have more than one flywheel on a single axle shaft. The construction of the flywheels can be efficient if a central steel disc is used and two cast lead collars are attached to the rim on both sides of the web disc. This produces a flywheel which is as cheap and effective as can conveniently be made.

Although it is not shown on the diagram shown above, Chas does use additional discs. These are not particularly heavy, but they will have some flywheel effect. Ideally, these discs should be beefed up and given considerable weight so that they contribute substantially to the overall power gain of the device. This is what Chas’ present build looks like:

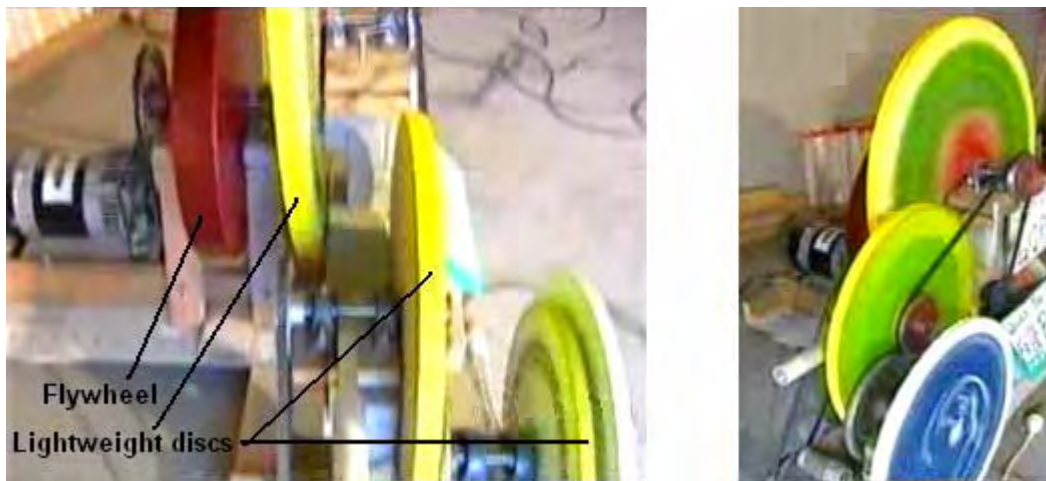

A possible alternative construction might be:

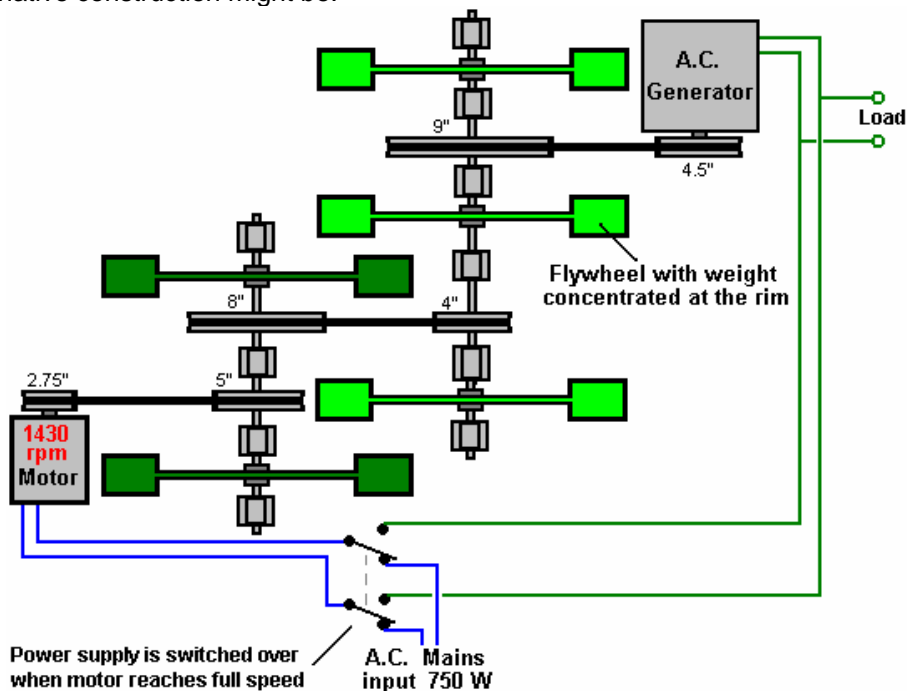

Here, there are five heavy flywheels mounted on two heavily supported strong axes, and while the two shown in dark green are only rotating at half the speed of the other three, the energy gain will be equal for each flywheel as each receives the same train of drive pulses. However, the pulley sizes might be better

chosen in accordance with Jacob's observations mentioned below.

The drive impulses can be from a DC motor fed with electrical pulses, perhaps via a standard "DC motor speed controller" or using electrical pulses to drive a series of permanent magnets spaced out around the edge of a circular rotor. In this instance, the electrical generation can be via a standard commercial generator, or it can be produced by using the electromagnet driving coils alternately to drive and to capture electrical energy. The following sketch shows a possible arrangement for this concept:

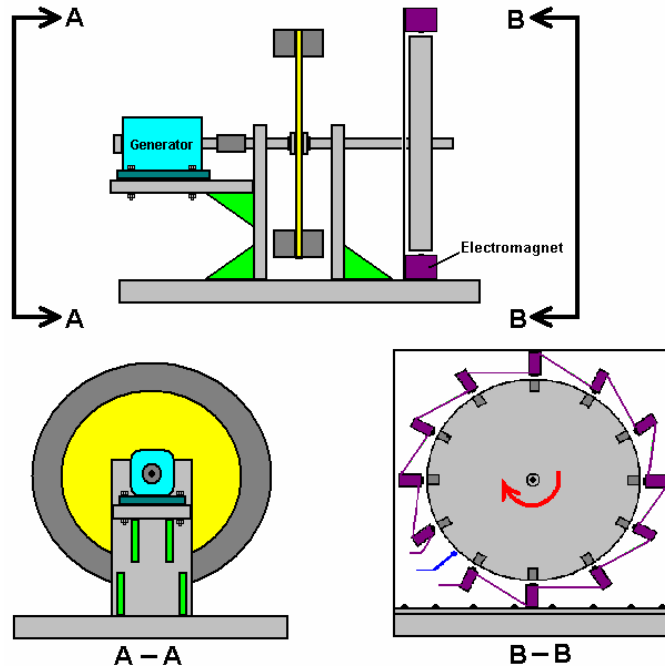

Jacob Byzehr's Analysis.

In 1998, Jacob lodged a patent application for a design of the type shown by Chas Campbell. Jacob has analysed the operation and he draws attention to a key design factor:

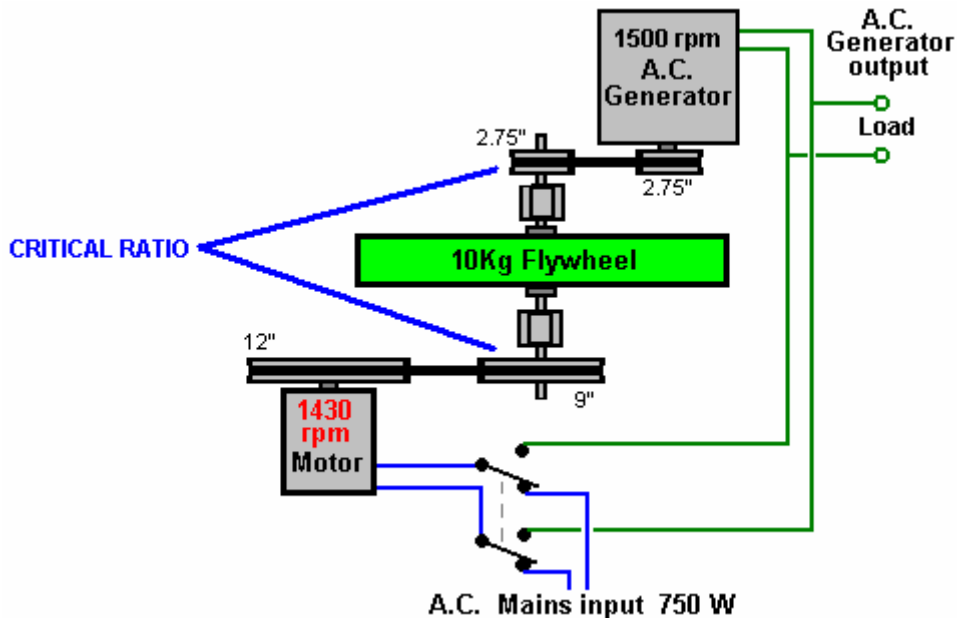

Jacob states that a very important feature for high performance with a system of this kind is the ratio of the diameters of the driving and take-off pulleys on the shaft which contains the flywheel, especially with systems where the flywheel rotates at high speed. The driving pulley needs to be three or four times larger than the power take-off pulley. Using Chas' 1430 rpm motor and a commonly available 1500 rpm generator, the 12:9 step-up to the shaft of the flywheel gives a satisfactory generator speed while providing a 3.27 ratio

between the 9-inch diameter driving pulley and the 2.75" diameter power take-off pulley. If a generator which has been designed for wind-generator use and which has its peak output power at just 600 rpm is used, then an even better pulley diameter ratio can be achieved.

The Wilson Self-Powered DC Generator

Mr. Wilson of Texas built a self-powered generator system using an old table and some car parts. His construction was shaky, but in spite of that, it powered itself and other equipment. The table which he used was five feet (1.5 m) in diameter and 2-inches (50 mm) thick which means that it will have weighed at least 130 pounds or 60 Kilograms which is a substantial amount, well in excess of that used by Chas Campbell with his AC self-powered system. In this DC construction the system was driven by a standard, unmodified, off-the-shelf DC motor powered by two car batteries wired in parallel to give a larger current capacity. These batteries were kept charged up by two 'generators' from pre-1964 American cars (the closest available today are permanent magnet alternators). These generators also powered additional equipment and Mr Wilson pointed out that three or more generators could be run by the system, giving a substantial level of excess electrical power.

The machine has to be described as 'shaky' because he chose to convert the table top into a V-pulley belt drive flywheel by driving a series of nails into the edge of the wooden disc, with those nails angled to form a V shaped gap through which he ran a pulley belt. After three days of continuous running, those nails started to come out, causing him to power the system down. This unit was built around 1990, and if anyone decides to attempt a replication, then I suggest that the rim of the wooden disc is grooved to take the belt rather than relying on nails. The arrangement was like this:

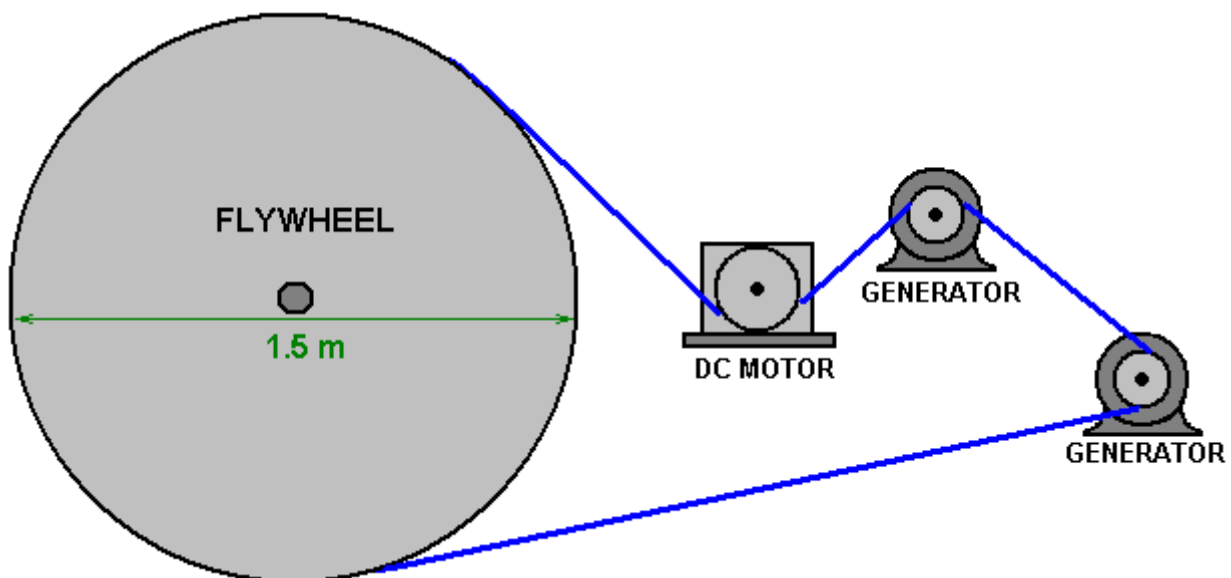

There was also a belt-tensioning roller which is not shown in the diagram above which assumes that the flywheel has been grooved to take the drive belt. Schematically, the arrangement was like this:

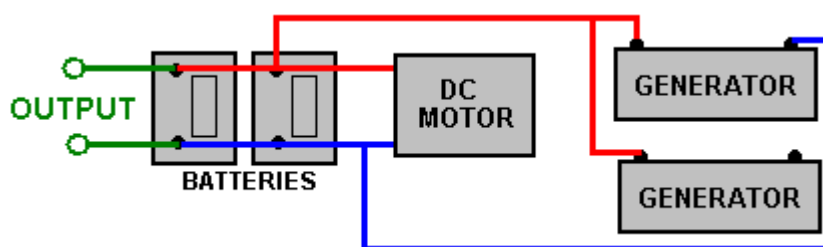

Here, the additional output can be used directly for powering 12-volt equipment or an inverter can be used to provide mains voltage and frequency. A typical inverter looks like this:



The battery power is connected to one end using thick cables to carry the heavy current, and one or more mains sockets are provided at the other end of the case, along with an On/Off switch and power indicators. Inverters come in many sizes and power ratings, generally ranging from 150 watts to 3,000 watts (3 kW). The more expensive ones are specified as “True Sine-Wave Output” but very few present day items of equipment will not run well on the cheaper versions which do not produce a true sine-wave output.

Mr Wilson decided not to patent his design and instead wanted it to be open-source information for anybody to use freely. However, the Jesse McQueen patent shown in chapter 13 looks to be Mr Wilson’s design although the flywheel does not appear to be mentioned there. It should be stressed that the generator output needs to be high and so permanent magnet types are considered to be essential for this application. The specialised motor (and consequently, generator) winding methods of ‘UFOpolitics’ shown in chapter 2, raise efficiencies by a factor of typically 300% or more, and so would raise the output of this system very substantially if they were applied to the motor, or the generators, or both.

John Bedini’s COP=8 Pulsed Flywheel.

The Chas Campbell system is not an isolated case. On page 19 of the book “Free Energy Generation - Circuits and Schematics” John Bedini shows a diagram of a motor/generator which he has had running for three years continuously while keeping it’s own battery fully charged.

At John’s web site <http://www.icehouse.net/john1/index11.html> about half way down the page, there is a black and white picture of a very large construction version of this motor. The important thing about this motor is that it is being driven by electrical pulses which apply a continuous stream of short drive pulses to the flywheel. This extracts a steady stream of continuous energy drawn out from the gravitational field, enough to charge the driving battery and keep the motor running. The large version built by Jim Watson had an excess power output of many kilowatts, due to the very large size and weight of it’s flywheel.

The overall strategy for this is shown here:

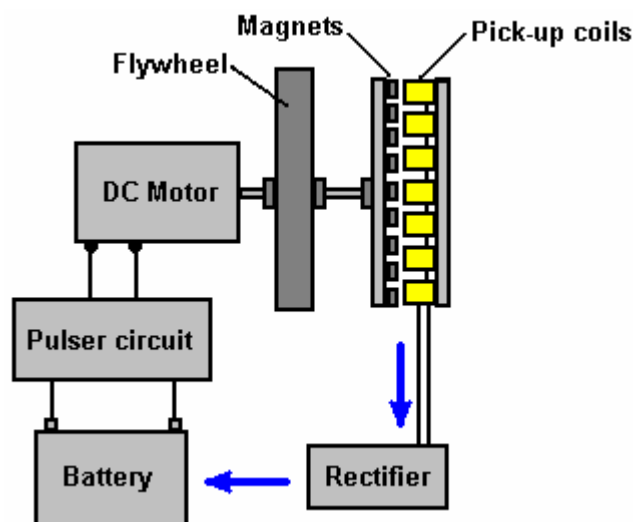

It is also likely that Joseph Newman's motor gains additional energy from its large physical weight of some 90 kilograms driven by a continuous stream of pulses. Any wheel or rotor assembly which is driven with a series of mechanical pulses, should benefit from having a serious flywheel attached to the shaft, or alternatively, the outer edge of the rotor. Engineers consider that effect of a flywheel on an irregular system is to iron out the irregularities in the rotation. That is correct as a flywheel does do that, but Lawrence Tseung's gravity "lead-out" theory indicates that those irregular pulses also add energy to the system.

With John's system, a capacitor is charged by the generator coils and then the drive circuit is effectively disconnected from the battery and the contents of the capacitor dumped into the battery. Then the capacitor link is effectively disconnected and the drive section connected again so that the process can be repeated indefinitely. While one flywheel is shown, there is no reason why more than one may not be used. Also, while only one set of magnets and pickup coils is shown, more can easily be added. The larger the system gets, the greater the available excess power becomes. An asymmetrically wound motor (chapter 2) should be considered when choosing a drive motor.

James Hardy's Self-Powered Water-Jet Generator.

As described in more detail in Chapter 2 and Chapter 8, there is a very simple device based on a high-power water pump. In this system, a small quantity of water is pumped around continuously, in the same general style as an ornamental fountain. The difference here is that a high speed jet of water is produced and directed at a turbine wheel. The turbine wheel can be of any type as indicated in the patent which James has been awarded for this design. In the video at present on the web, the water wheel is of very simple design and yet works well – it is shown here:



Small discs are attached to the wheel at widely spaced intervals around its rim. The water jet hits these and applies an impulse to the wheel, driving it around, but also adding extra energy through those impulses.

The waterwheel is coupled to a standard electrical generator via pulleys and V-belts. The system is started using the mains supply and then when it is running at full speed, the electrical supply for the pump is switched over from the mains to the output of its own generator. This is exactly the same as Chas Campbell does with his pulsed flywheel and both systems are capable of powering additional standard electrical equipment intended for mains use.

Chas Campbell's flywheel, John Bedini's flywheel and this water-jet generator all demonstrate very clearly that environmental energy is readily available for us to use any time we choose to do so. All that is necessary is for us to construct one of these devices.

The Permanent Magnet Pendulum.

At the present time, there is a short video clip on YouTube, showing a pendulum which has been running unaided for two years: <http://www.youtube.com/watch?v=SZjNbjhxgt4> and which uses both gravity and magnetism to keep going. The device is installed in a case with transparent sides:



The pendulum itself looks rather like a sledgehammer due to its rigid shaft and the additional magnets mounted on the weight. The above picture shows the pendulum at the end of its swing to the right and the picture below, in its extreme left hand swing position:



Which indicates the swing covers a fairly short distance. Mounted near the top of the pendulum, there are two pivoted arms which look quite like microphones, due to having large magnets mounted on their innermost ends:

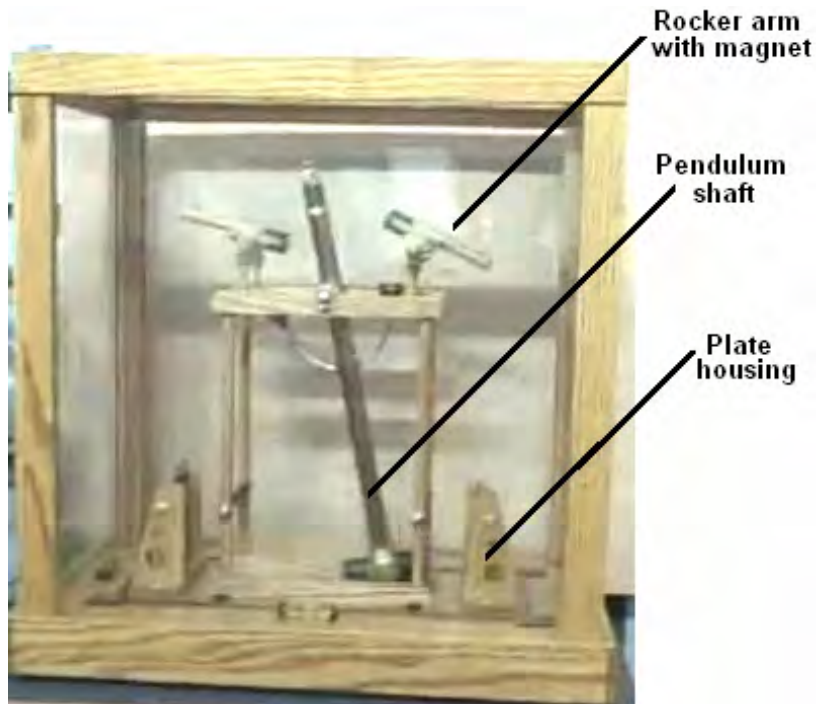

The device operates like this: The pendulum swings to the right and as it does so, it raises a magnet attached to the pendulum shaft by a curved silver arm:



Presumably, the arm is curved to avoid the constructional complications at the pendulum pivot which would be caused by a straight mounting arm attached to the pendulum shaft. The rising magnet attached to the pendulum pushes the magnet end of the rocker arm upwards even though it does not come close to it.

The rocker arm is used to raise and lower a plate which has a magnet mounted in it. The raising and lowering is achieved by having two cords attached to the end of the rocker arm and their other ends attached to the two upper corners of the moving plate:



The plate slides in two slots in the support housing and the plate movement is relatively small:



The tipping up of the lever arm drops the plate down as the pendulum approaches the plate. This introduces a magnetic braking effect where some of the momentum of the pendulum weight is stored in the opposing magnetic fields of the pendulum magnets and the plate magnet. This brakes the pendulum movement and gives it a magnetic push on its opposite swing, sustaining it's swinging day after day after day.

This is a clever arrangement and the device on display has been built to a very high standard of construction. It does not appear to have any additional energy take off, but seems quite likely that air-core coils could be used along the swing path to generate electrical power. The arrangement appears so close to John Bedini's pendulum battery charger that it may well be possible to use a pendulum of this type to charge batteries just as John does.

While this looks like a very simple device, it is highly likely that it requires exact adjustment of the length of the lever arms, the magnetic gap sizes in relation to the strength of the magnets, etc. etc. Repeated small adjustments are probably needed to get the device operating smoothly and sustaining the pendulum swing. All in all though, it is a very interesting device.

Jerzy Zbikowshi's Mechanical Power Amplifier.

We come now to a device which I would love to describe as "impossible" but reluctantly, I can't actually do that. On the surface, this device has every appearance of being impossible, and yet it has been measured in a laboratory as being 147% efficient. Perhaps the laboratory measurements are wrong, however, there seems to be very little scope for measurement error as the device is so basically simple. My problem is that if the results are 100% genuine, which is distinctly possible, then a series of these arranged in a circle, each driving the next one, it would create a self-powered device and I can't explain where the driving power would come from. I can understand pretty much every other device in this eBook, but this one has me stumped. As I don't have any basis for claiming to be a genius, I am sharing the information here and I will let you decide if it can work as the patent claims that it does.

The patent in question is the very innocent looking US 7,780,559 entitled "Chain Transmission" which innocently states that it is a single-chain system for rotating a large gearwheel at the same rate as a smaller, driving gearwheel, and without question, that is exactly what it does. At this point, my Engineering training jumps in and says "sure, but the overall mechanical efficiency will be less than 100% and while the larger gearwheel does rotate at the same rate, it will do so far less powerfully, and you have exactly the same effect as driving the second shaft with a small gearwheel which has a large gearwheel bolted to it.

The only problem with this is that testing appears to show that this is not the case and in fact, (probably due to the larger lever arm of the larger gearwheel radius) the arrangement has an output power which was measured in the prototype as being 47% greater than the input power. OK, so how does it work?

In the diagram shown here, a small-diameter driving wheel marked "1" has exactly the same number of teeth as the much larger driven wheel marked "2". As they are linked by a chain, these two wheels rotate at exactly the same rate, that is, the revolutions per minute are exactly the same for each of those two wheels.

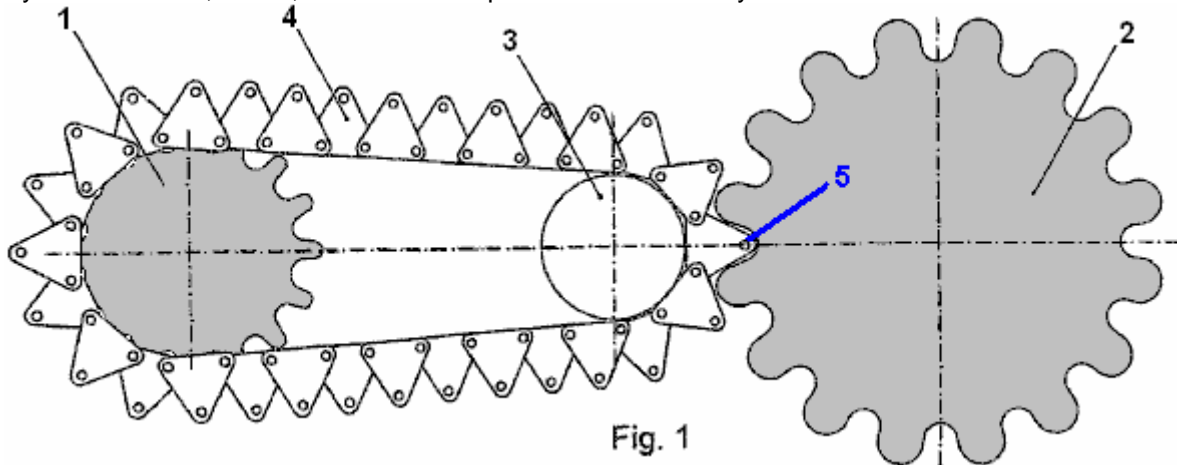

The way that the chain manages to push the larger teeth of the large wheel is by having the driving roller "5" raised by a triangular link "4" so that it has the same rotational pitch as the teeth on the larger wheel.

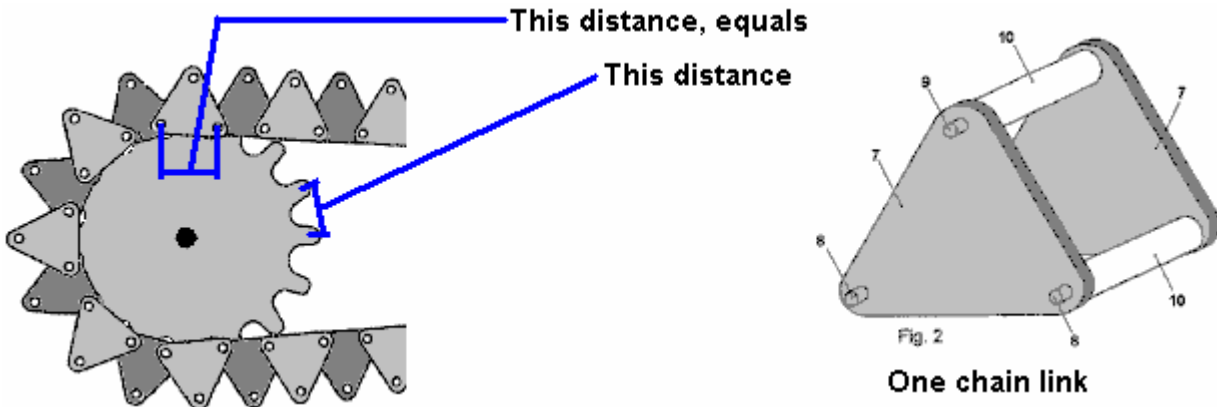

My immediate reaction to this is to say that as the triangular links in the drive chain have a somewhat narrower base than their height, that this will cause the driving roller "5" to have a less powerful drive than

the driving wheel “1”. But if the lab measurements made on the prototype are correct, then that increased level arm effect is not sufficient to overcome the gains caused by the increased radius of the larger wheel. The lab measurements were made at the certified laboratory of the Institute of Electrical Machines and Drives of the Technical University of Wrocław, Poland. A video presentation in Polish can be seen at <http://www.focus.pl/video/film/perpetuum-mobile/>. It is difficult to see how this chain drive could be COP>1 but it has the advantage that anyone with good mechanical construction skills can test it without the need for any knowledge of electronics.

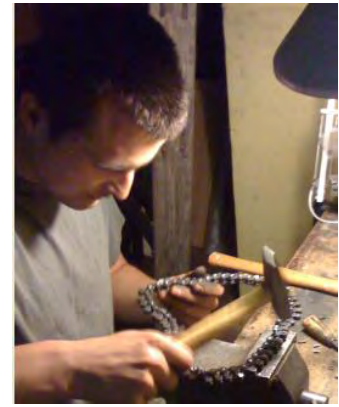

Gravitational Effects.

We are all familiar with the effects of gravity. If you drop something, it falls downwards. Engineers and scientists are usually of the opinion that useful work cannot be performed on a continuous basis from gravity, as, they point out, when a weight falls and converts its “potential energy” into useful work, you then have to put in just as much work to raise the weight up again to its starting point. While this appears to be a sound analysis of the situation, it is not actually true.

Some people claim that a gravity-powered device is impossible because, they say that it would be a “perpetual motion” machine, and they say, perpetual motion is impossible. In actual fact, perpetual motion is not impossible as the argument on it being impossible is based on calculations which assume that the object in question is part of a “closed” system, while in reality, it is most unlikely that any system in the universe is actually a “closed” system, since everything is immersed in a massive sea of energy called the “zero-point energy field”. But that aside, let us examine the actual situation.

Johann Bessler made a fully working gravity wheel in 1712. A 300 pound (136 Kg) wheel which he demonstrated lifting a 70 pound weight through a distance of 80 feet, demonstrating an excess power of 5,600 foot-pounds. Considering the low level of technology at that time, there would appear to be very little scope for that demonstration to be a fake. If it were a fake, then the fake itself would have been a most impressive achievement.

However, Bessler acted in the same way as most inventors, and demanded that somebody would have to pay him a very large amount of money for the secret of how his gravity wheel worked. In common with the present day, there were no takers and Bessler took the details of his design to the grave with him. Not exactly an ideal situation for the rest of us.

However, the main argument against the possibility of a working gravity wheel is the idea that as gravity appears to exert a direct force in the direction of the earth, it therefore cannot be used to perform any useful work, especially since the efficiency of any device will be less than 100%.

While it is certainly agreed that the efficiency of any wheel will be less than 100% as friction will definitely be a factor, it does not necessarily follow that a successful gravity wheel cannot be constructed. Let us apply a little common sense to the problem and see what results.

If we have a see-saw arrangement, where the device is exactly balanced, with the same length of a strong plank on each side of the pivot point, like this:

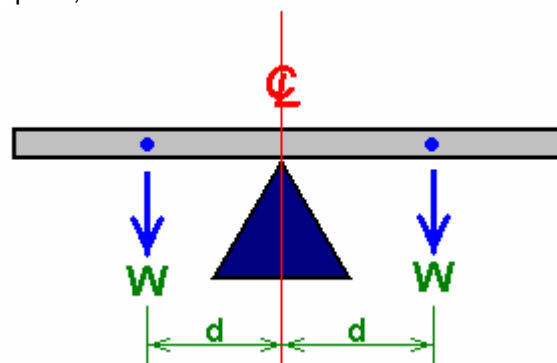

It balances because the weight of the plank (“W”) to the left of the support point tries to make the plank tip over in a counter-clockwise direction, while exactly the same weight (“W”) tries to tip it over in a clockwise direction. Both turning forces are d times W and as they match exactly, the plank does not move.

The turning force (d times W) is called the “torque”, and if we alter the arrangement by placing unequal weights on the plank, then the beam will tip over in the direction of the heavier side:

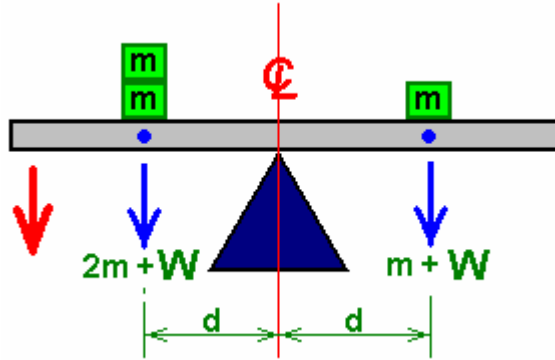

With this unequal loading, the beam will tip down on the left hand side, as indicated by the red arrow. This seems like a very simple thing, but it is a very important fact. Let me point out what happens here. As soon as the weight on one side of the pivot is bigger than the weight on the other side (both weights being an equal distance from the pivot point), then the heavy plank starts to move. Why does it move? Because gravity is pushing the weights downwards.

One other point is that the distance from the pivot point is also important. If the added weights “ m ” are equal but placed at different distances from the pivot point, then the plank will also tip over:

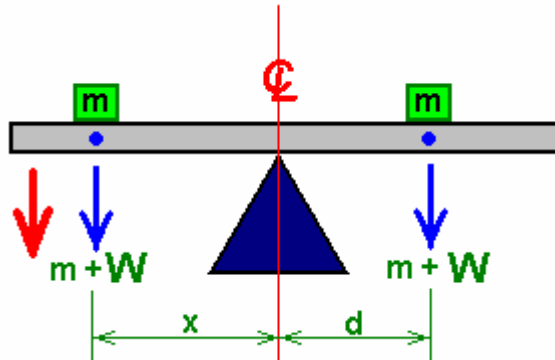

This is because the larger lever arm “ x ” makes the left hand weight “ m ” have more influence than the identical weight “ m ” on the right hand side.

Do you feel that these facts are just too simple for anyone to really bother with? Well, they form the basis of devices which can provide real power to do real work, with no need for electronics or batteries.

The following suggestions for practical systems are put forward for you to consider, and if you are interested enough test out. However, if you decide to attempt to build anything shown here, please understand that you do so entirely at your own risk. In simple terms, if you drop a heavy weight on your toe, while other people may well be sympathetic, nobody else is liable or responsible for your injury - you need to be more careful in the future ! Let me stress it again, this document is for information purposes only.



The Deflected-Weight Generator of Mikhail Dmitriev.

Mikhail is a Russian experimenter who has worked for many years developing and testing gravity-powered devices. His persistence has paid off and he has been very successful. His work is shown on Sterling Allan’s web site http://peswiki.com/index.php/Directory:Mikhail_Dmitriev_Gravity_Wheel where there are videos and photographs of several of his prototypes. It is envisaged that large versions which generate 6 to 12 kilowatts of excess power will become available for purchase in 2011. Each of his various designs is

based on the principle of having weights attached to a wheel and arranging for those weights to be offset outwards when falling and offset inwards when rising. Because of the different lever arms involved, that gives a force imbalance which causes the wheel to rotate continuously and if the weights are of a considerable size, then the rotation is powerful and can be used to generate electrical energy.

In order to arrange for the weights to be offset as the wheel goes around, each weight is suspended on a pivoted arm:



For the device to operate as required, that suspension arm needs to be moved to (say) the right when falling and be centred or deflected to the right when rising. Mikhail has chosen to use a small amount of electrical power to make this happen, because the energy provided by gravity in turning the wheel far outweighs the small electrical input needed to make the wheel rotate.

Several mechanisms for making this happen have been tested as you can see from Sterling's presentation. One method is to push the lever arms to the right with a simple rotating disc which has deflector arms attached to it:



After being given the sideways push, each weight stays off centre until it reaches the bottom of its travel. Please remember that while the weights shown here are tiny, a full-size working device will have weights which weigh a total of perhaps 130 kilograms and the forces involved are then large. The picture above is a little difficult to make out as the rotating disc is transparent and the support for the rotating arms is also transparent. The horizontal metal arm is there to support the transparent panel on which the 'arms wheel' bearing is mounted.

An alternative method is to use a small motor which drives the arms directly as shown here:

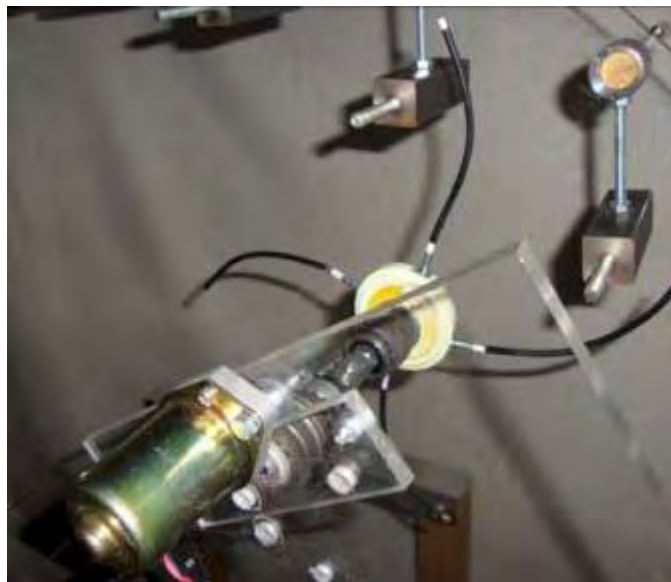

Each weight is held rigidly and so when the motor arm presses against it, the lever arm is pushed out sideways without the weight twisting away from the motor arm. These prototype weights are not heavy, but when a working unit is being built they will have considerable weight, so to get a well balanced arrangement, it might be advisable to have weights on both sides of the wheel so that there is no offset axial load placed on the shaft which supports the wheel:

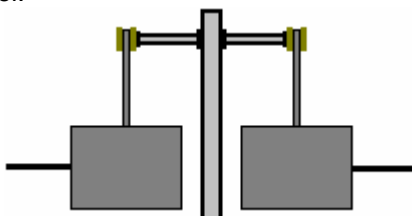

Mikhail's arrangement works well when it relies on the swinging movement of the weights to keep them off centre during the time when they are falling and you can watch a video of that happening. However, it makes one wonder if it would not be possible to arrange for this movement without the need for a motor, although using a motor is a very clever and sensible method of ensuring rotational power. Perhaps if two stationary deflectors were used, one to keep the weights out to the right when falling and one to keep them out to the right when rising, a viable system might be created. Perhaps something like this:

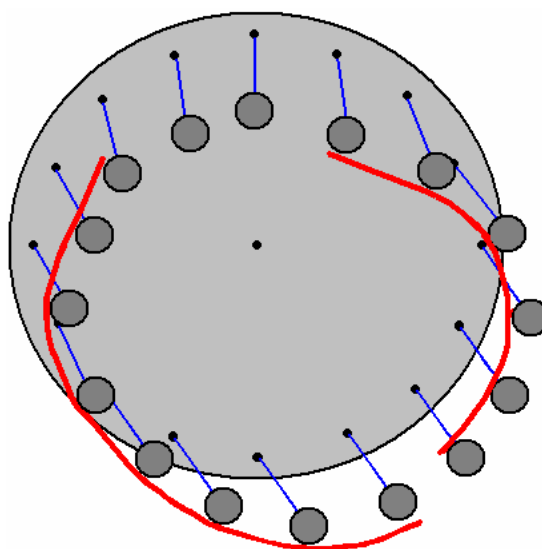

Admittedly, the deflector pieces would have a smoother shape than drawn here, but the principle is shown in spite of the poor quality of the diagram. Where heavy weights are involved, each could have a roller bearing pressing between the weight and the deflector shield in order to minimise friction as the weight slides past. Alternatively, the deflector shield could be faced with powerful magnets opposing similar magnets attached

to the weights which would give a no-contact, very low friction movement. A fairly similar idea is part of the next entry from Dale Simpson.



Dale Simpson's Gravity Wheel Suggestion.

The design of gravity-operated machines is an area which has been of considerable interest to a number of people for quite some time now. The design shown here comes from Dale Simpson of the USA. It should be stressed that the following information is published as open-source, gifted to the world and so it cannot be patented by any individual or organisation. Dale's prototype wheel has a diameter of about five feet, utilising weights of a substantial value. The overall strategy is to create excess torque by having the weights slide along metal rods radiating from a central hub somewhat like the spokes of a cart wheel. The objective is to create an asymmetrical situation where the weights are closer to the hub when rising, than they are when falling.

The difficulty with designing a system of this type is to devise a successful and practical mechanism for moving the weights in towards the hub when they are near the lowest point in their elliptical path of movement. Dale's design uses a spring and a latch to assist control the movement of each weight. The key to any mechanical system of this type is the careful choice of components and the precise adjustment of the final mechanism to ensure that operation is exactly as intended. This is a common problem with many free-energy devices as careless replication attempts frequently result in failure, not because the design is at fault, but because the necessary level of skill and care in construction were not met by the person attempting the replication. Here is a sketch of Dale's design:

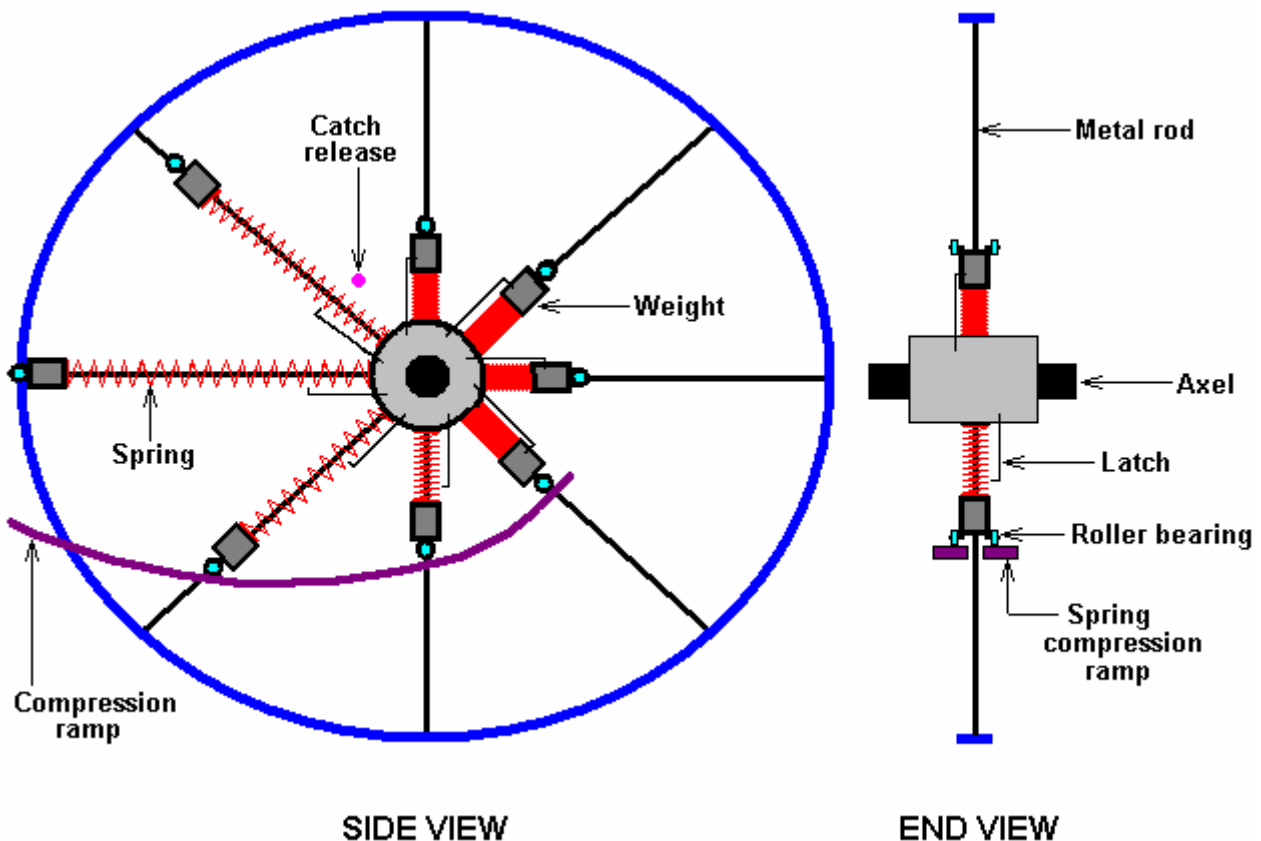

The wheel has an outer rim shown in blue and a central hub shown in grey. Metal spokes run out radially from the hub to the rim. Eight spokes are shown in this diagram as that number allows greater clarity, but a larger number would probably be beneficial when constructing a wheel of this type.

The wheel as shown, rotates in a counter-clockwise direction. Each weight, shown in dark grey, has a pair of low-friction roller bearings attached to it. There is also a spring, shown in red, between the weight and the hub. When a weight reaches the 8-o'clock position, the roller bearings contact a spring compression ramp, shown in purple. This ramp is formed of two parts, one on each side of the spokes, providing a rolling ramp for each of the two roller bearings. The ramp is formed in a curve which has a constant rate of approach towards the hub of the wheel.

The ramp is positioned so that the spring is fully compressed when the weight has just passed the lowest point in its travel. When the spring is fully compressed, a latch holds it in that position. This holds the weight in close to the hub during its upward movement. The springs are not particularly powerful, and should be just strong enough to be able to push the weight back towards the rim of the wheel when the spoke is at forty five degrees above the horizontal. The "centrifugal force" caused by the rotation assists the spring move the weight outwards at this point. The push from the spring is initiated by the latch being tripped open by the latch release component shown in pink.

The weights have an inward motion towards the hub when they are pushed by the wheel's turning motion which forces the roller bearings upwards along the spring-compression ramp. They have an outward motion along the spokes when the catch holding the spring compressed is released at about the 11-o'clock position. The latch and the release mechanism are both mechanical - no electronics or electrical power supply is needed in this design.

These details are shown in the diagram below:

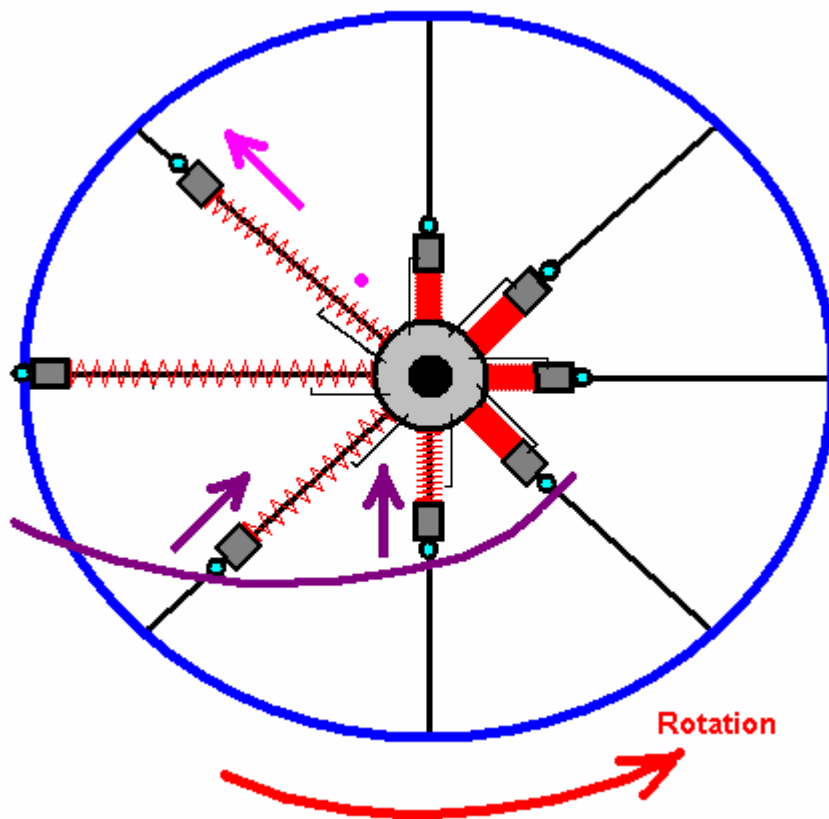

The question, of course is, will there be enough excess power to make the wheel rotate properly? The quality of construction is definitely a factor as things like the friction between the weights and their spokes needs to be very low. Let us consider the forces involved here:

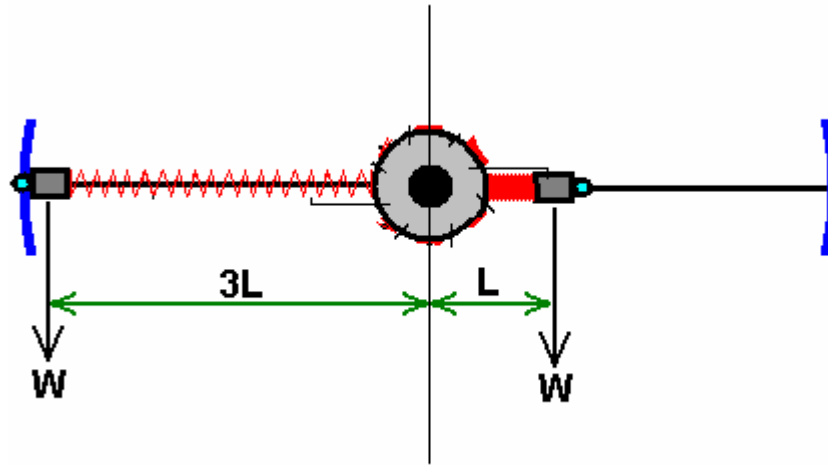

Take any one weight for this calculation. Any excess rotational energy will be created by the difference between the forces attempting to turn the wheel in a clockwise direction and those forces trying to turn the wheel in a counter-clockwise direction. For the purpose of this discussion, let us assume that we have built the wheel so that the compressed-spring position is one third of the spring-uncompressed position.

As the weights are all of the same value "W", the see-saw turning effect in a clockwise direction is the weight ("W") multiplied by it's distance from the centre of the axle ("L"). That is, $W \times L$.

The turning effect in the counter clockwise direction is the weight ("W") multiplied by it's distance from the centre of the axle (" $3W$ "). That is, $W \times 3 \times L$.

So, with WL pushing it clockwise, and $3WL$ pushing it counter-clockwise, there is a net force of $(3WL - WL)$, i.e. a net force of $2WL$ driving the wheel in a counter-clockwise direction. If that force is able to push the weight in towards the hub, compressing the spring and operating the spring latch, then the wheel will be fully operational. There is actually, some additional turning power provided by the weights on the left hand side of the diagram, both above and below the horizontal, as they are a good deal further out from the axle than those with fully compressed and latched springs.

The only way of determining if this design will work correctly is to build one and test it. It would, of course, be possible to have several of these wheels mounted on a single axle shaft to increase the excess output power available from the drive shaft. This design idea has probably the lowest excess power level of all those in this document. The following designs are higher powered and not particularly difficult to construct.

The Abdulsalam Al-Mayahi Gravity Wheel

This design for a gravity-operated wheel capable of generating electrical power on a continuous basis, comes from Abdulsalam Al-Mayahi, is of very simple construction and currently is the subject of a patent application. While it looks something similar to Dale Simpson's design shown above, they actually have very little in common. This design does not have springs or latches but instead, operates on a combination of momentum and gravitational forces.

The implementation of the design shown here, while simple in concept, uses fairly sophisticated mechanical parts. There is a good chance that if carefully built and well lubricated, that a relatively crude version built from scrap components found locally, could function perfectly well.

This design does not claim to self-start from a stationary position but is intended to be started manually, spinning it up to speed so that the inertial effects push the weights out to the rim of the wheel with the need to roll along the inner deflection rail. The set-up is like this:

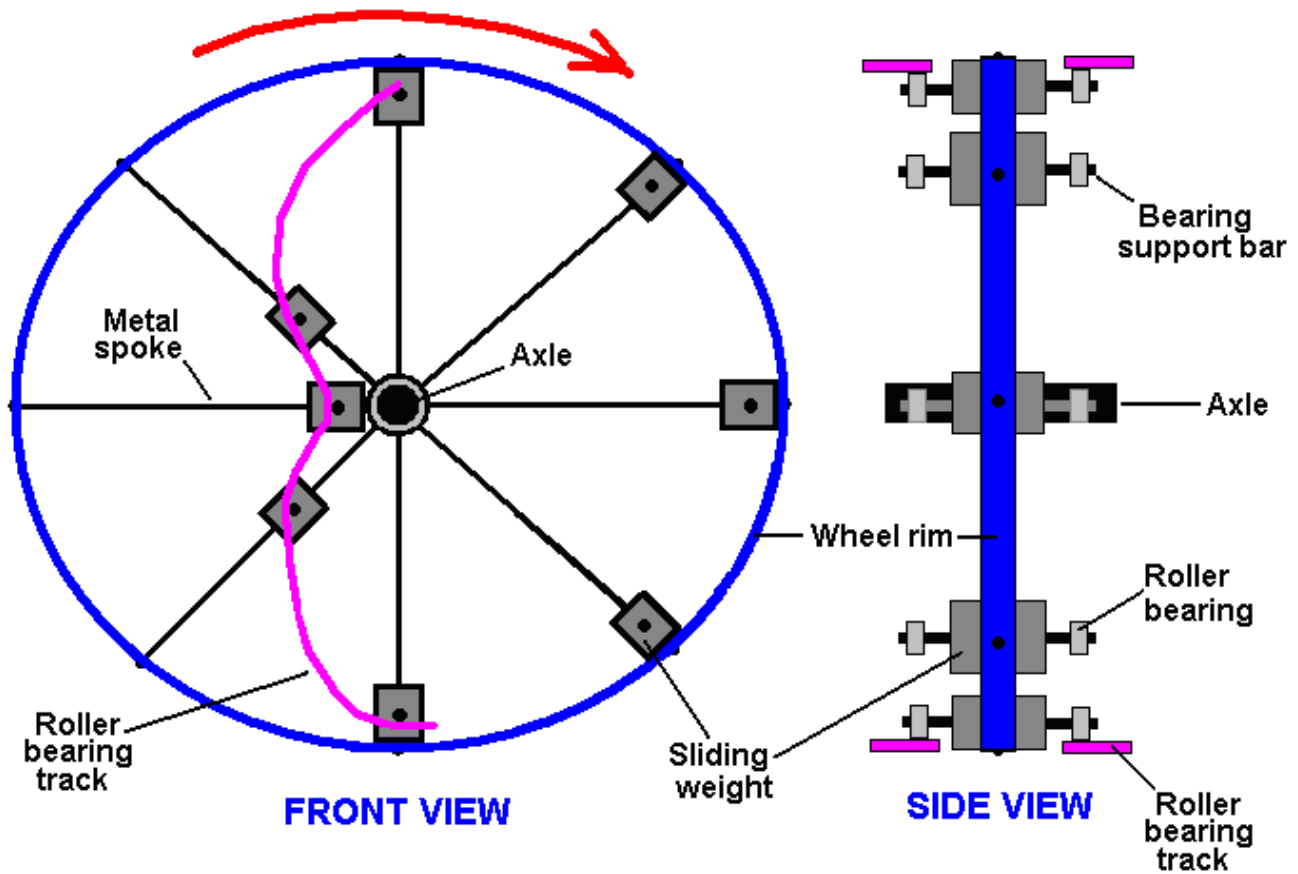

This gravity-powered motor has a metal rim (shown in blue in the diagram above) supported by a number of metal spokes which radiate outwards from the central axle hub which is of robust construction. On each spoke, there is a substantial sliding weight and each of these weights has a metal bar projecting outwards from its centre of gravity, supporting a roller bearing on each side of the weight.

The generator is initially spun by hand or by a starter motor. This causes the weights to be pressed outwards by the forces resulting from this rotation. Each weight would normally then be pressed against the metal rim as its circular path can only happen if there is a continuous inward acceleration towards the axle.

This normal situation is not allowed to occur as a stationary roller bearing track is installed. The roller bearing of each weight encounters this track or deflection rail, when it reaches the lowest point in its movement. The very start of the track is tangential to the bearing's movement so that there is no impact when the bearing first touches the track. As the wheel continues to rotate, the track forces the weight inwards towards the axle, much of the energy required to do this, coming from the momentum of the weight itself. The shape of the track is arranged so that the weight reaches the axle hub during a 90-degree rotation of the wheel. It is also shaped in such a way that the distance travelled up the spoke is constant for each degree of rotation. This ensures that the weight-sliding operation is smooth and continuous.

This forced movement causes the counter-clockwise rotational torque to be far less than the clockwise rotational torque because each weight in this "6 o'clock to 9 o'clock" sector is much closer to the axle than are the weights at the opposite side of the wheel in the "12 o'clock to 3 o'clock" sector.

The roller-bearing track continues through the "9 o'clock to 12 o'clock" sector, allowing each weight to gradually return to the rim of the wheel, but doing this without getting far away from the axle, thus adding further to the torque imbalance as each of the weights in the opposing "3 o'clock to 6 o'clock" sector are fully extended to the rim of the wheel and so are producing their maximum torque as the wheel rotates. This torque imbalance not only keeps the wheel rotating, but it also provides excess power for other applications such as spinning an electrical generator.

The power of the wheel can be increased by:

- (a) Increasing the mass of each weight, and/or
- (b) Increasing the diameter of the wheel, and/or
- (c) Mounting two or more wheels on the axle, (ideally, separated angularly in order to provide the smoothest operation possible).

To assist with getting the generator spinning, a second weight-deflection rail is introduced:

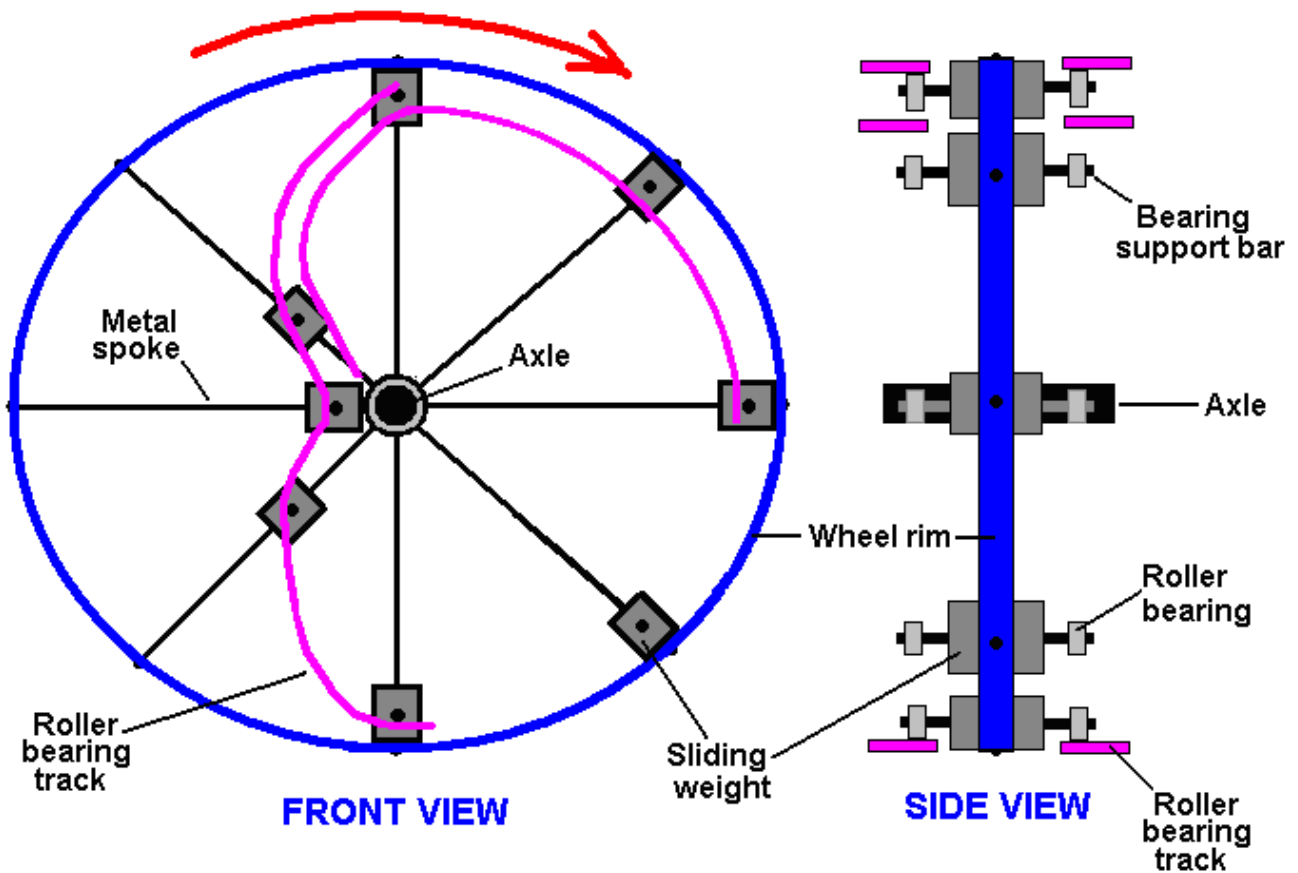

During normal, full-speed operation, this second track does not touch the roller bearings at all as each weight is pressed tightly against the rim of the wheel, but during the start-up process, this additional track ensures that the weights stay out near the rim in the critical “12 o'clock to 3 o'clock” sector and follow the desired path in the “9 o'clock to 12 o'clock” sector.

In the diagrams shown above, only one gravity-driven wheel is shown. While this is a perfectly viable arrangement, the output power can be increased by attaching additional wheels with their spokes and weights. As the wheels are located side by side, it is possible to use a single roller-bearing track to support the bearings on each side of it as shown here:

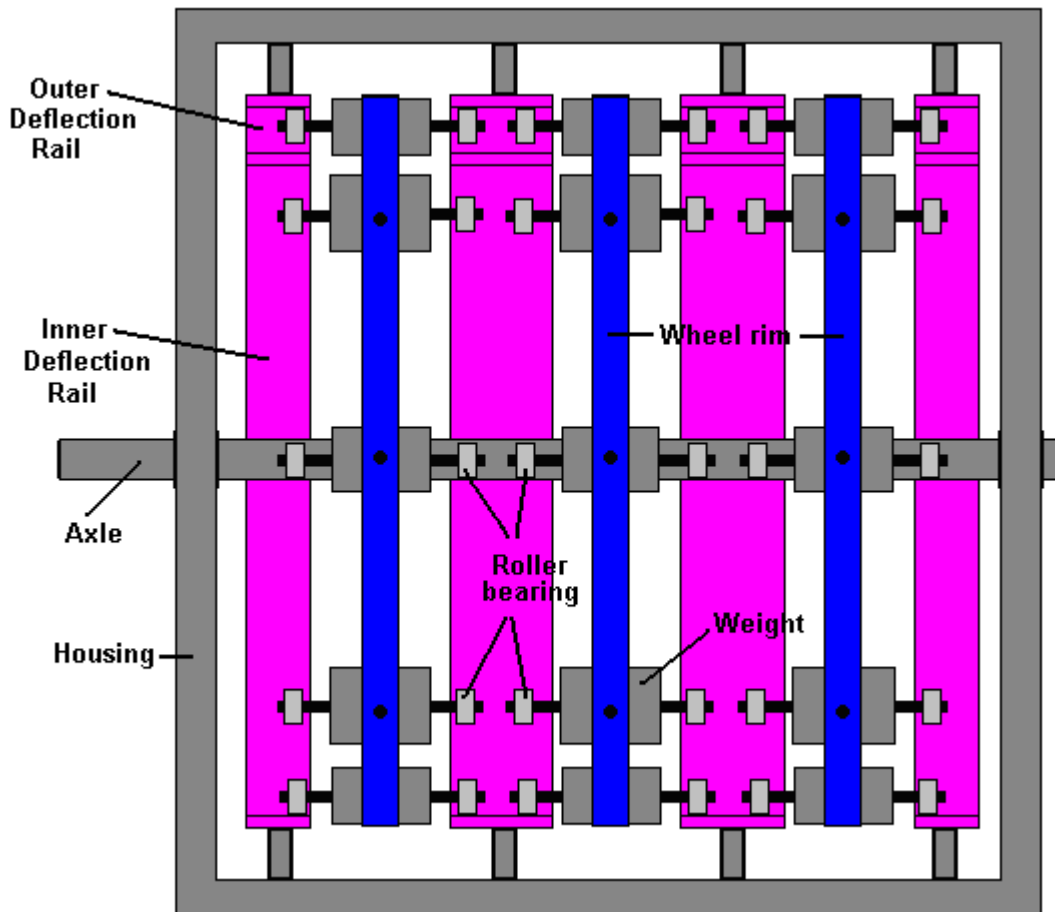

An important feature of this design is the minimising of friction between the weights and the rods which they slide along. This is particularly important at the “6 o'clock” to “9 o'clock” region where the weights have to alter direction rapidly and will press strongly against the spokes of the wheel when they are doing this. To minimise the friction encountered by the sliding weights, one effective option is to install a pair of roller bearings on all four sides of the spoke, eight bearings in all, embedded in each weight. To facilitate this, each weight can comprise four sections as shown here:

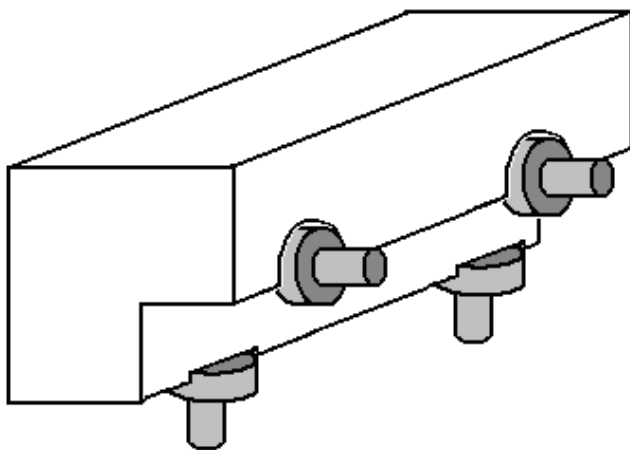

PERSPECTIVE VIEW

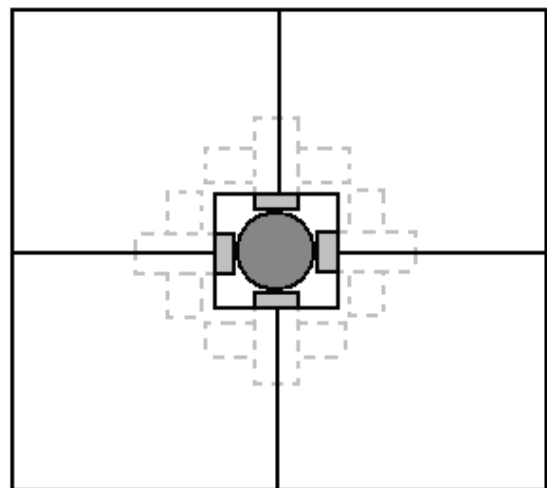

END VIEW

While the motion of the weight along the spoke has been described as “sliding”, the reality is that the weights roll along the spokes supported on four sides by the roller bearings. A piece of cushioning material is placed on the rim or on the weights in order to soften the impact when they come together.

Veljko Milkovic's Pendulum/Lever System.

The concept that it is not possible to have excess power from a purely mechanical device is clearly wrong as has recently been shown by Veljko Milkovic at <http://www.veljkomilkovic.com/OscilacijeEng.html> where his two-stage pendulum/lever system shows a COP = 12 output of excess energy. COP stands for "Coefficient Of Performance" which is a quantity calculated by dividing the output power by the input power **which the operator has to provide** to make the system work. Please note that we are talking about power levels and not efficiency. It is not possible to have a system efficiency greater than 100% and it is almost impossible to achieve that 100% level.

Here is Veljko's diagram of his very successful lever / pendulum system:

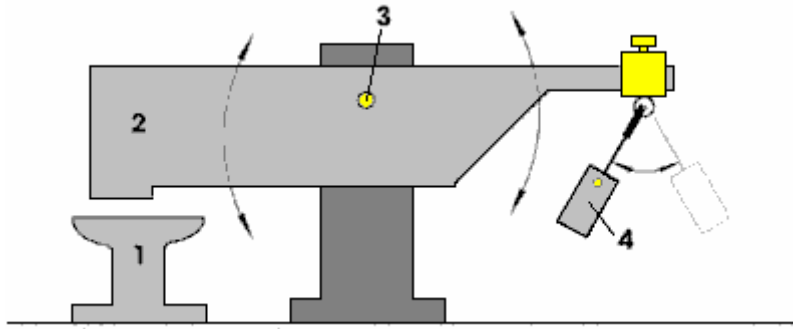

Here, the beam 2 is very much heavier than the pendulum weight 4. But, when the pendulum is set swinging by a slight push, the beam 2 pounds down on anvil 1 with considerable force, certainly much greater force than was needed to make the pendulum swing.

As there is excess energy, there appears to be no reason why it should not be made self-sustaining by feeding back some of the excess energy to maintain the movement. A very simple modification to do this could be:

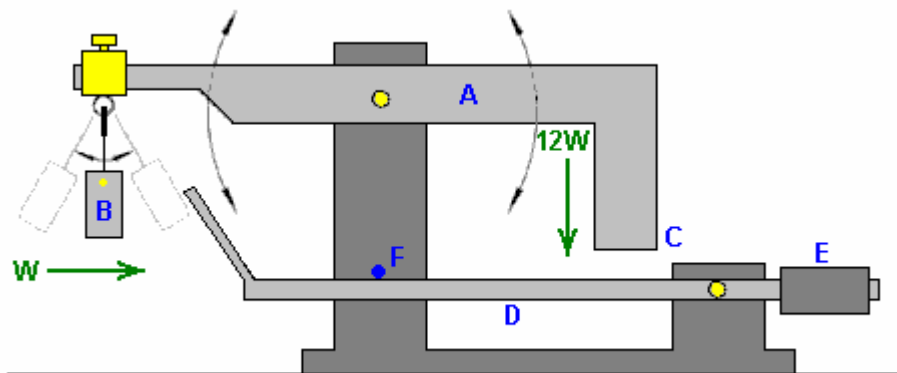

Here, the main beam A, is exactly balanced when weight B is hanging motionless in its "at-rest" position. When weight B is set swinging, it causes beam A to oscillate, providing much greater power at point C due to the much greater mass of beam A. If an additional, lightweight beam D is provided and counterbalanced by weight E, so that it has a very light upward pressure on its movement stop F, then the operation should be self-sustaining.

For this, the positions are adjusted so that when point C moves to its lowest point, it just nudges beam D slightly downwards. At this moment in time, weight B is at its closest to point C and about to start swinging away to the left again. Beam D being nudged downwards causes its tip to push weight B just enough to maintain its swinging. If weight B has a mass of "W" then point C of beam A has a downward thrust of $12W$ on Veljko's working model. As the energy required to move beam D slightly is quite small, the majority of the $12W$ thrust remains for doing additional useful work such as operating a pump.

Amr Al-Hossary's Patent.

If that is the case, then the design should perhaps be modified along the lines of the patent application of Amr Al-Hossary where the hinged plates are attached directly to the rotor. That way, the plate lever arm definitely comes into play:

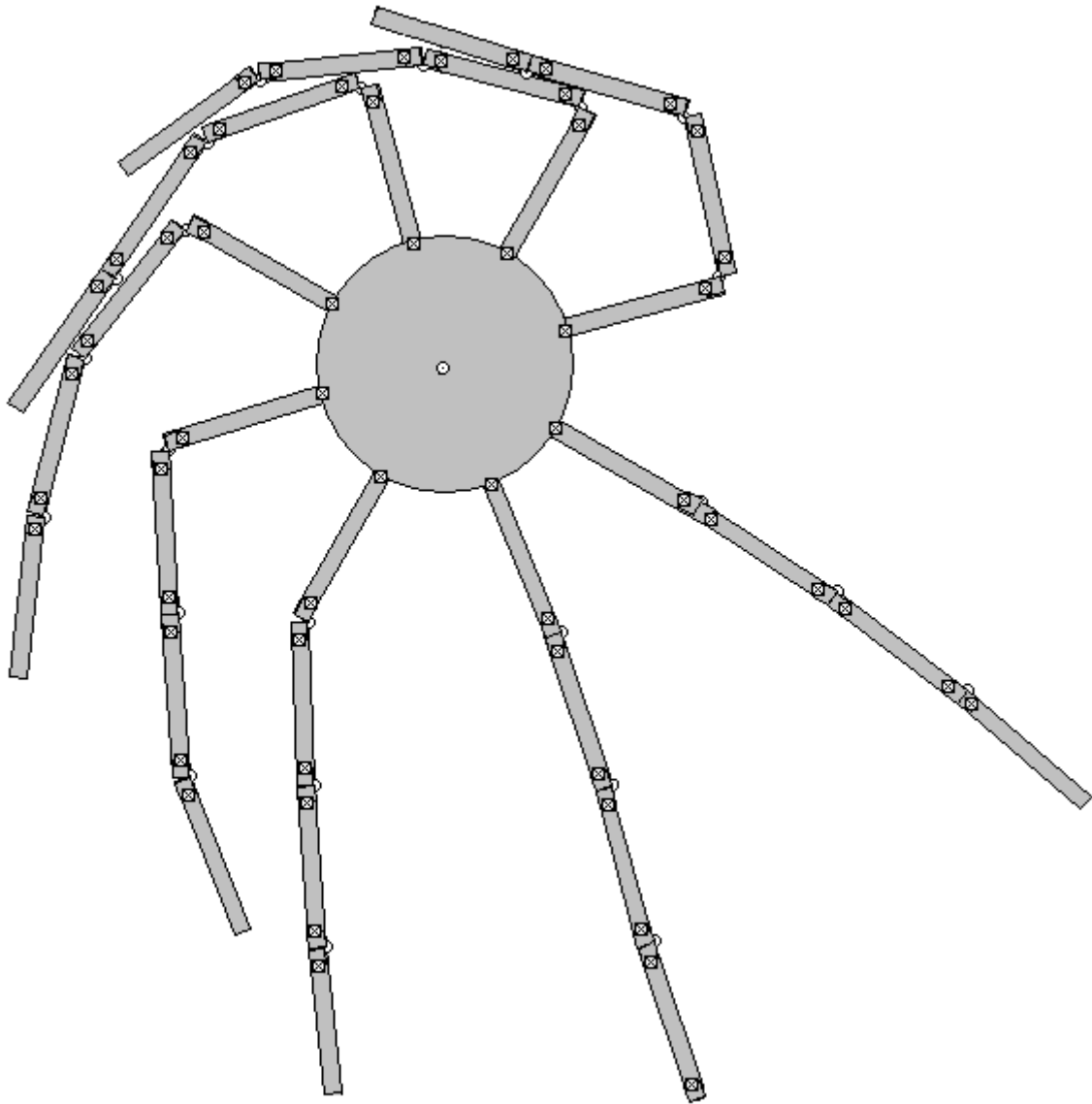

Here, the hinged arms or plates will also give an impact impulse when they open out to their full extent and that provides additional turning power. However, the imbalance between the two side is not a major amount and so this design is not likely to provide a large amount of torque for driving external loads.

Murilo Luciano's Gravity Chain Suggestion.

Murilo Luciano of Brazil, has devised a very clever, gravity-operated power device which he has named the "Avalanche-drive". Again, this design cannot be patented as Murilo has gifted it to the world as a royalty-free design which anybody can make. This device continuously places more weights on one side of a drive shaft to give an unbalanced arrangement. This is done by placing expandable links between the weights. The links operate in a scissors-like mode which open up when the weights are rising, and contract when the weights are falling:

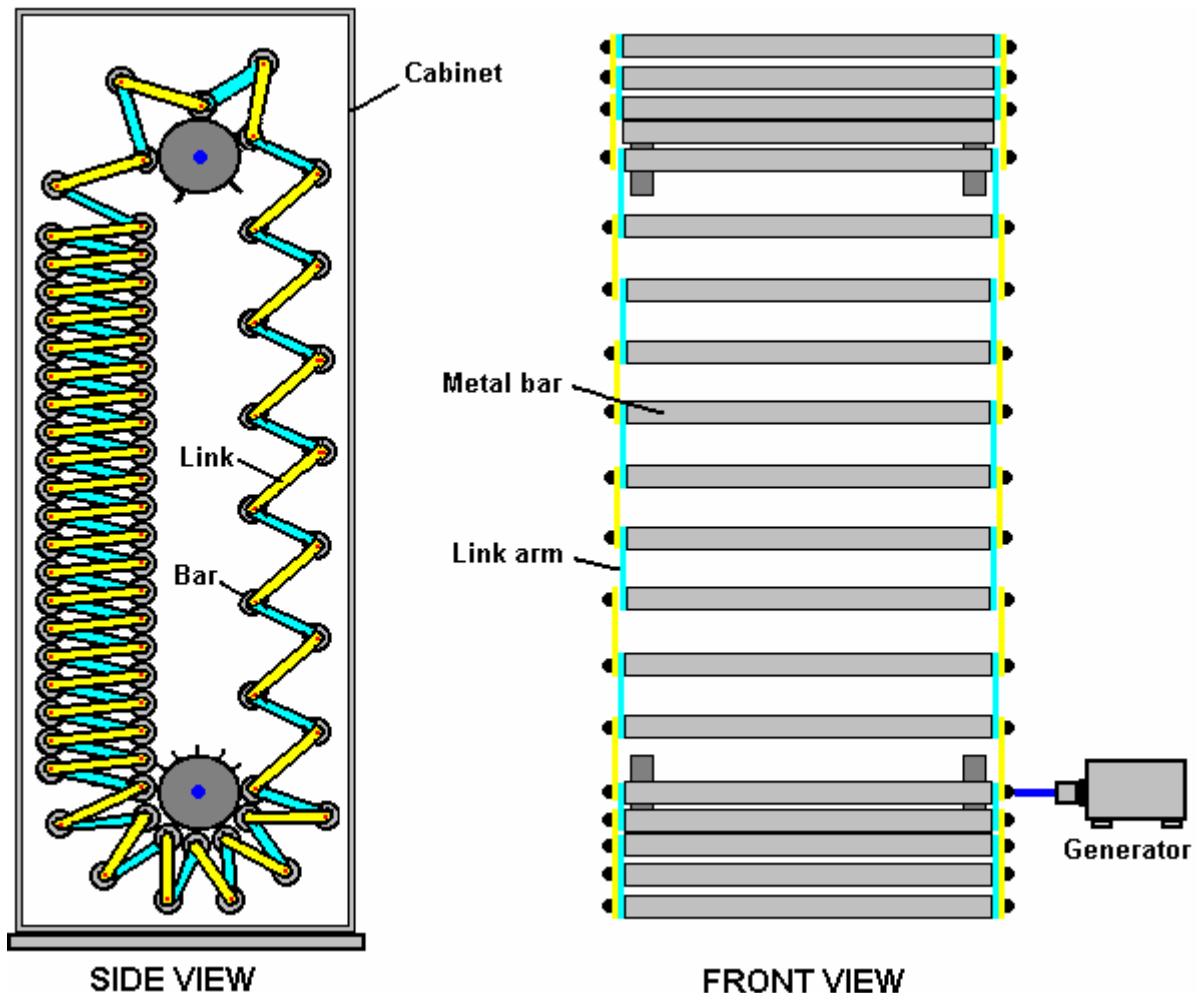

In the arrangement shown here, the weights are shown as steel bars. The design is scalable in both height, width and the mass and number of weights. In the rough sketch above, the practical details of controlling the position of the bars and co-ordinating the rotation of the two support shafts are not shown in order to clarify the movement. In practice, the two shafts are linked with a pair of toothed sprockets and a chain. Two sets of vertical guides are also needed to control the position of the bars when they are in-between the four sprockets which connect them to the drive shafts, and as they go around the sprocket wheels.

In the sketch, there are 79 bar weights. This arrangement controls these so that there are always 21 on the rising side and 56 on the falling side (two being dead-centre). The resulting weight imbalance is substantial. If we take the situation where each of the linking bars weighs one tenth as much as one of the bar weights, then if we call the weight of one link "W", the rising side has 252 of these "W" units trying to turn the sprockets in a clockwise direction while 588 of the "W" units are trying to turn the sprockets in an counter-clockwise direction. This is a continuous imbalance of 336 of the "W" units in the counter-clockwise direction, and that is a substantial amount. If an arrangement can be implemented where the links open up fully, then the imbalance would be 558 of the "W" units (a 66% improvement) and the level arm difference would be substantial.

There is one other feature, which has not been taken into account in this calculation, and that is the lever arm at which these weights operate. On the falling side, the centre of the weights is further out from the axis of the drive shafts because the link arms are nearly horizontal. On the rising side, the links are spread out over a lesser horizontal distance, so their centre is not as far out from their supporting sprocket. This difference in distance, increases the turning power of the output shafts. In the sketch above, an electrical generator is shown attached directly to one output shaft. That is to make the diagram easier to understand, as in practice, the generator link is likely to be a geared one so that the generator shaft spins much faster than the output shaft rotates. This is not certain as Murilo envisages that this device will operate so rapidly that some form of braking may be needed. The generator will provide braking, especially when supplying a heavy electrical load.

This diagram shows how the two side of the device have the unbalanced loading which causes a counter-clockwise rotation:

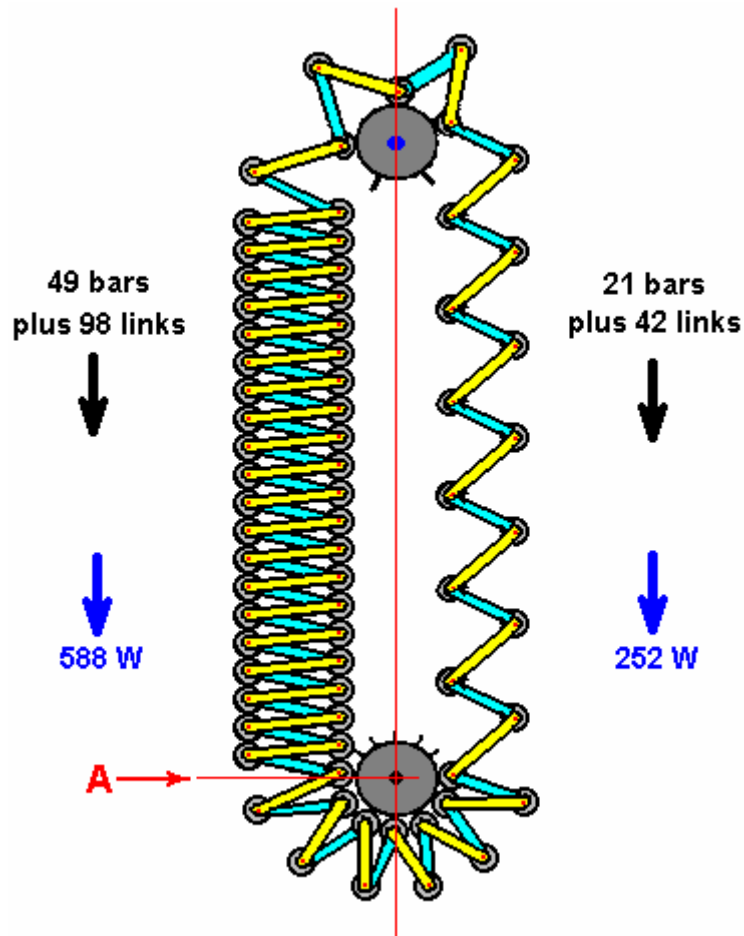

The diagrams shown above are intended to show the principles of how this device operates and so for clarity, the practical control mechanisms have not been shown. There are of course, many different ways of controlling the operation and ensuring that it works as required. One of the easiest building methods is to link the two shafts together using a chain and sprocket wheels. It is essential to have the same number of bar weights passing over the upper sprocket wheels as pass under the lower sprocket wheels. On the upper sprocket wheels, the bars are spread out, say, three times as far apart than they are on the lower sprocket wheels, so the upper sprockets need to rotate three times as fast as the lower ones. This is arranged by using a lower drive-chain sprocket wheel which has three times the diameter of the upper one.

The driving force provided by the weight imbalance of the two columns of rod weights needs to be applied to the lower sprocket wheels at point "A" in the diagram above. For this to happen, there has to be a mechanical connection between the stack of bar weights and the sprocket wheel. This can be done in different ways. In the above concept diagrams, this link has been shown as a sprocket tooth or alternatively, a simple pin projection from the sprocket wheel. This is not a good choice as it involves a considerable amount of machining and there would need to be some method to prevent the bar rotating slightly and getting out of alignment with the sprocket wheel. A much better option is to put spacers between the bar weights and have the sprocket teeth insert between the bars so that no bar slots are needed and accurate bar positioning is no longer essential. This arrangement is shown below:

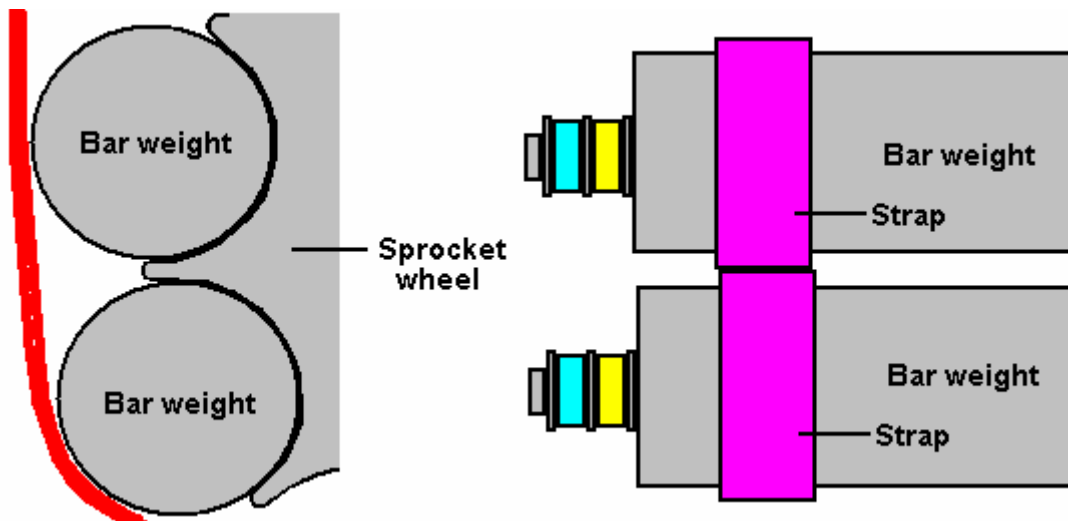
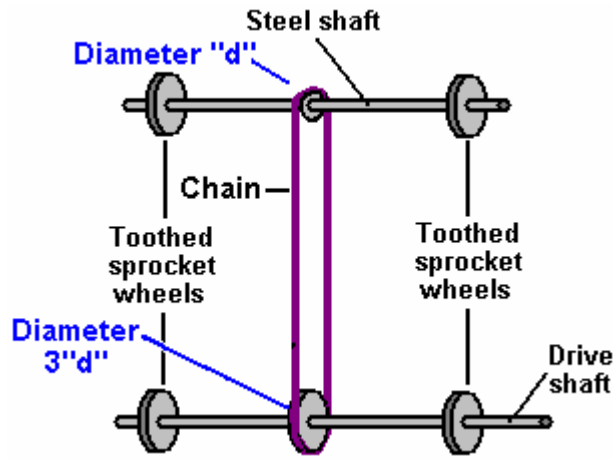

The description up to here has not mentioned the most important practical aspects of the design. It is now time to consider the rising side of the device. To control the expanded section of the chain, and to ensure that it feeds correctly on to the upper sprocket wheels, the gap between successive bar weights must be controlled.

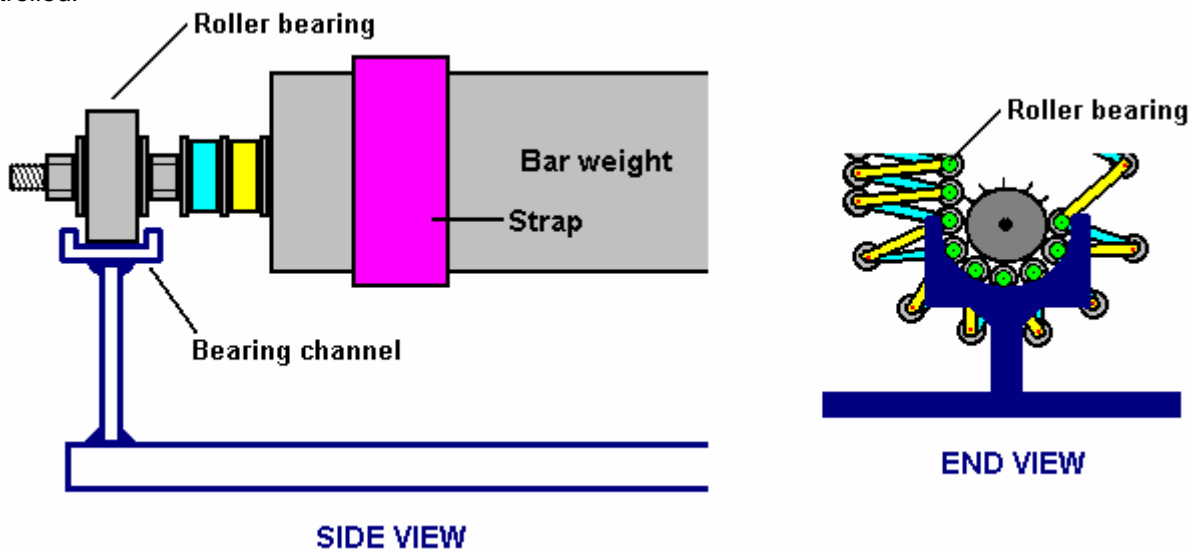

A guiding channel can be used, as shown here, and standard ball-bearings or roller-bearings can be attached to the ends of the weights by using threaded rod (or a bolt with the head inside the weight) and locking nuts.

In the example shown here, which is of course, just one option out of hundreds of different implementations, the bars on the rising side are three times as far apart as those on the falling side. This means that on the upper sprocket wheels, only every third tooth will connect with a bar weight. This is shown in the following diagram. However, if the linked weights were left to their own devices, then the rising side bars would hang down in one straight line. While that would be optimum for drive power, Murilo does not envisage that as a practical option, presumably due to the movement of the links as the bar weights move over their highest point. In my opinion, that arrangement is quite possible to implement reliably provided that the length of the links is selected to match the sprocket distance exactly, however, Murilo's method is shown here.

Murilo's method is to use additional restraining links between the weights. The objective here is to make sure that when the weights spread out on their upward journey, that they take up positions exactly three bar widths apart, and so feed correctly on to the teeth of the upper sprocket wheel. These links need to close up on the falling side and open up on the rising side. They could be fabricated from short lengths of chain or from slotted metal strips with a pin sliding along the slot.

Whichever method is chosen, it is important that the links stay clear of the bars and do not prevent the bars stacking closely together on the falling side as that would prevent them seating correctly on the teeth of the lower sprocket wheels. The easiest precision option for the home constructor is using chain, where two bar weights are positioned on the upper sprocket wheel to give the exact spacing, and the tensioned chain is welded in position, as shown below. Placing the chain inside a plastic tube causes it to take up an "A" shape standing outwards from the links when they move into their closed position. This keeps the chains from getting between the link bars. In addition, the chains are staggered from one pair of link bars to the next, as shown below, as an additional measure to keep the operation both reliable and quiet..

In the diagram below, only a few of these restraining links are shown in order to keep the diagram as simple as possible. It is not a good choice to make the upper bar sprocket wheels three times larger than the lower sprocket wheels as this would force both the rising and falling sections of chain out of the vertical, which in turn introduces friction against the guides. The central 1:3 gearing is needed to make sure that the chains on the rising side are fully stretched and the spacing of the bar weights matches the upper sprocket spacing exactly.

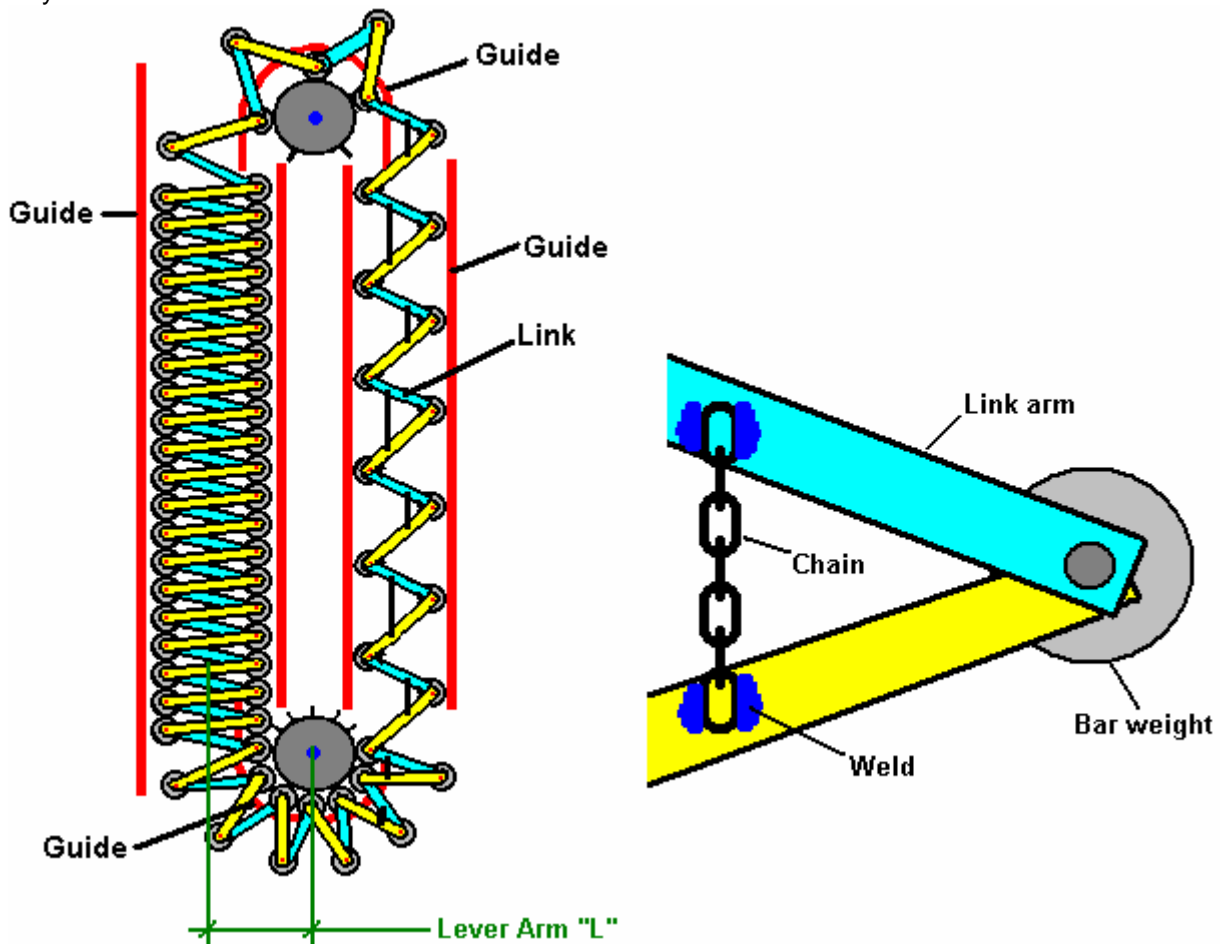

The diagrams have not shown the supporting framework which holds the axles in place and maintains the unit in a vertical position, as this framing is not specialised in any way, and there are many acceptable

variations. A sensible precaution is to enclose the device in an upright box cabinet to make sure that there is no chance of anything getting caught in the rapidly moving mechanism. This is an impressive design of Murilo's, who recommends that in the implementation shown above, that the links shown in blue are made 5% longer than those shown in yellow, as this improves the weight distribution and drive of the lower sprocket wheel.

A washing machine has a maximum power requirement of 2.25 kW and in the UK a suitable 3.5 kW alternator costs £225 and needs to be spun at 3,000 rpm for full output.

While the above description covers Murilo's main design, it is possible to advance the design further, raising its efficiency in the process as well as reducing the construction effort needed to build it. For this version, the main components remain the same, with the upper axle geared to the lower axle as before and the upper axle rotating faster than the lower one. The main difference is that on the rising side, the chain opens up completely. This does away with the need for the chain links, moves the rising weights much closer in and reduces the number of rising weights:

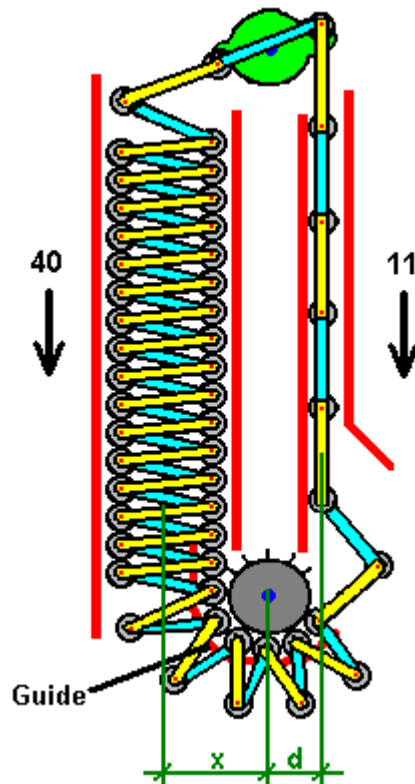

With a reduced number of weights in the diagram above, the weight imbalance is a very substantial 40:11 ratio with the massive advantage of a substantially reduced lever arm "d" which is much smaller than the lever arm "x" of the falling weights. This is a major imbalance, giving 40x pulling the axle in a counter-clockwise direction and only 11d opposing that movement.

In the description so far, it has been assumed that all components will be made of metal. This is not necessarily the best choice. Firstly, metal moving against metal does make a noise, so guides made robustly of thick plastic or other similar material would be a good choice for the guides for the weights.

The weights themselves could equally well be made from strong plastic piping filled with sand, lead pellets, concrete or any other convenient heavy material. The pipes would then have strong end caps capable of holding the pivots for the links. The sprocket wheels themselves could well be made from thick plastic material which would give a quieter operation and which could be bolted to the power take-off shaft with a bolt placed right through the axle.

Most of the dimensions are not critical. Increasing the diameter of the lower sprocket wheel will increase the power of the output axle but will lower its speed. Adding more weights will increase both the output power and to a lesser degree, the speed, but will increase the overall size of the unit and its overall weight and cost. Making each weight heavier will raise the output power, or reduce the overall size if the weight is contained in fewer weights. Increasing the length of the links means fewer weights on the rising side but will require larger sprocket wheels.

It is not necessary to have all the links the same size. If the lengths are chosen carefully and the indentations in the upper sprocket wheel cover the entire circumference, then every second link can be one indentation shorter which tips the weights into a more compact and effective column on the falling side:

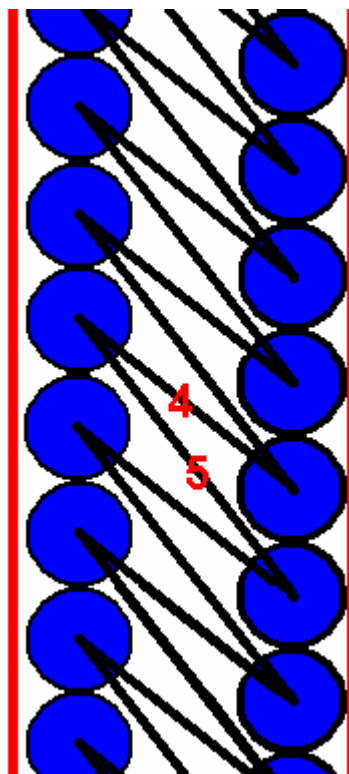
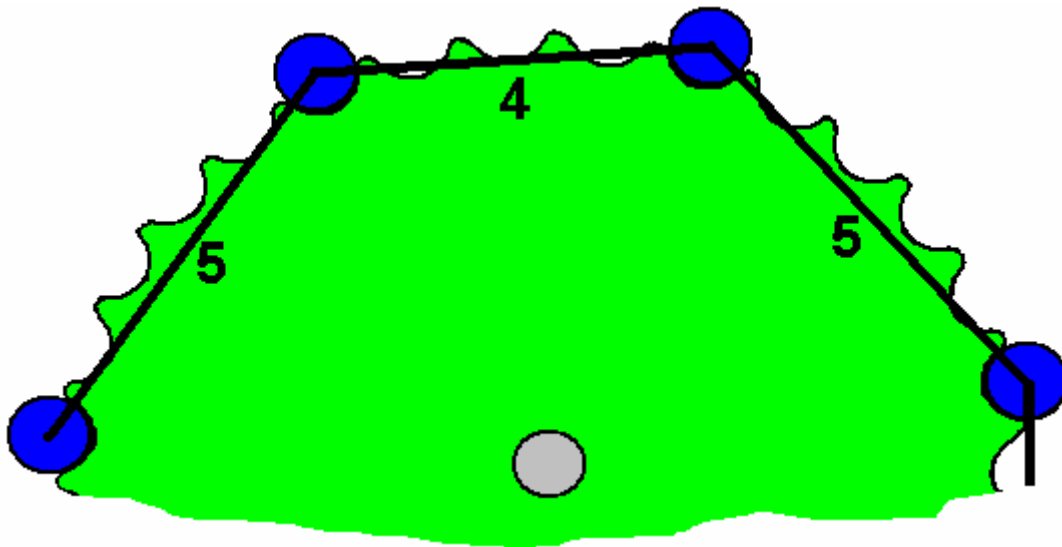

With this arrangement, the outer weights, shown here on the left, press down very firmly on the inside column of weights, making a compact group. If using plastic pipes with concrete then the hinge arrangement for the rods can be very simple, with a bolt set in the concrete as shown below.

The rods, washers and bolt can be supported on a thin, rigid strip placed across the top of the pipe. When the concrete has gone solid, the strip is removed and the gap produced by its removal then allows free movement of the rods. If this technique is used, then the bar weights are cast in two steps, with a tightly fitting disc pushed part way up inside the pipe so that one end can be filled while the other end remains open and ready for the completion of the other end.

One advantage of using plastic pipes is that if the sprocket wheels are made from a tough high-density plastic material, such as is used for food chopping boards, and the weight guides are also made from tough

plastic, then there should be no metal-upon-metal noise produced during operation, if the bolt holes in the connecting rods are a good fit for the bolts used.

The concrete or mortar used as a filling can be made wet and pliable, since mechanical strength is not an issue here, and a filling with no voids in it is desirable. Even low quality concrete (caused by more water than absolutely necessary) would be more than adequate for this purpose.

The arrangement at the ends of a concrete-filled plastic pipe bar weight could be constructed like this:

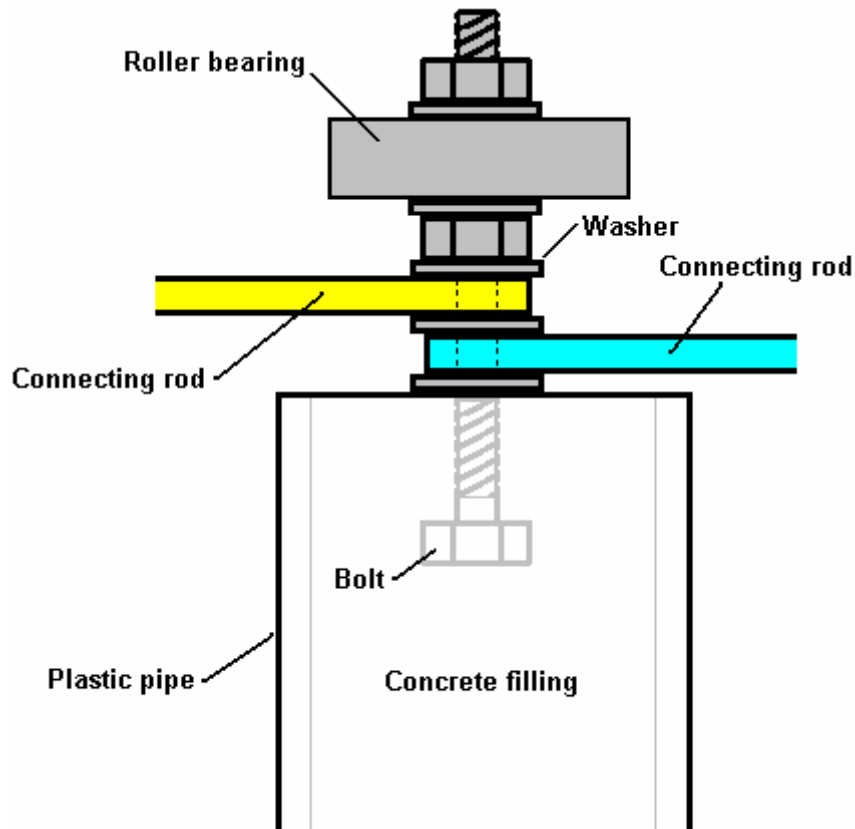

There is a very strong inclination when building a device to make it operate smoothly. Where excess energy is being drawn from the gravity field, the reverse is necessary, with a jerky operation being the optimum. Remember that the extra energy only occurs during the duration of the impulses causing the jerks. It follows then, that in an ideal situation, any device of this type should be driven by a rapid series of strong impulses. In practice, using a heavy flywheel or any similar component which has a high inertial mass, although a rapid series of sharp pulses is being applied to the component and jerky operation is not visible to the human eye, excess energy is still being "led-out" and made available to do useful work.

One other observation which may be of interest, and that is the feedback from builders of gravity wheels which says that the power output from a gravity wheel is greater if the axle is horizontal and the rotating wheel is aligned exactly with magnetic East-West.

A Practical Construction Query

I have just been asked about the practical issues of mounting the guiding components for the weights. I must apologise for not making it clear that the diagrams in this description are intended to show the overall methods of operation, rather than being a direct construction arrangement. There will be several ways of constructing an implementation of each device. Here is one suggestion for a practical construction method for the gravity chain device.

The query was as follows:

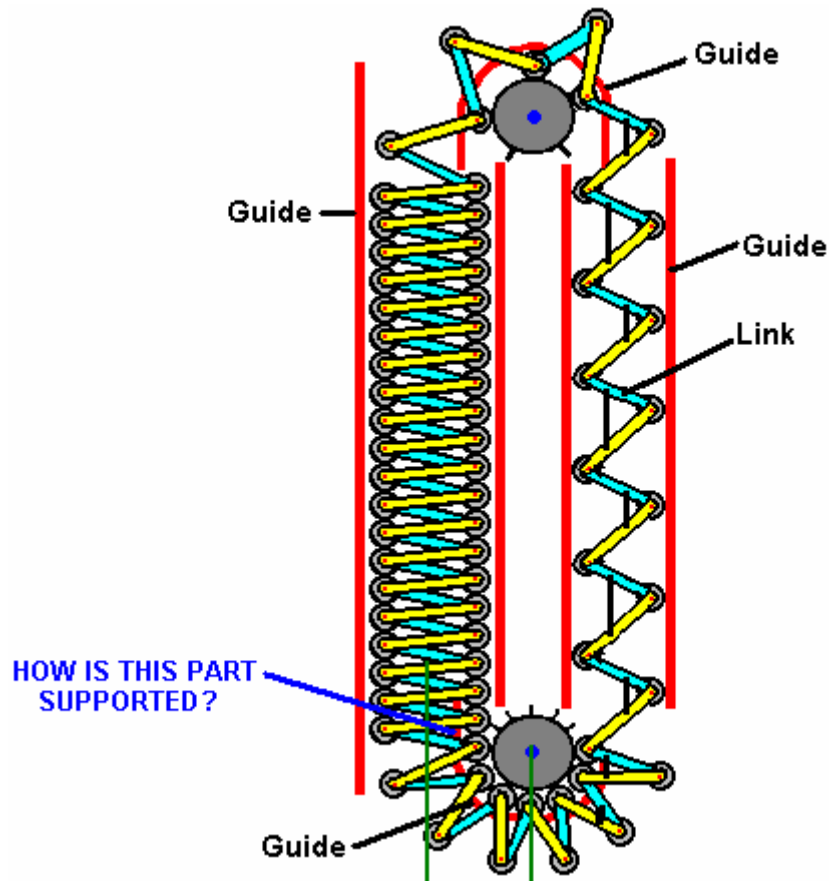

It is pointed out that the lower guide as shown, can't be supported from inside as the weights sweep through the area which would be used for that support. Also, it can't be supported from outside as the connecting rods have to move through the area where that support would be positioned. A solution has been suggested where the lower guide is supported by a strap from the upper guide, the strap running between the inner and outer weights. That is a solution which could work, but it introduces significant unnecessary friction. An alternative method is to place the guides outside the moving weights as shown here:

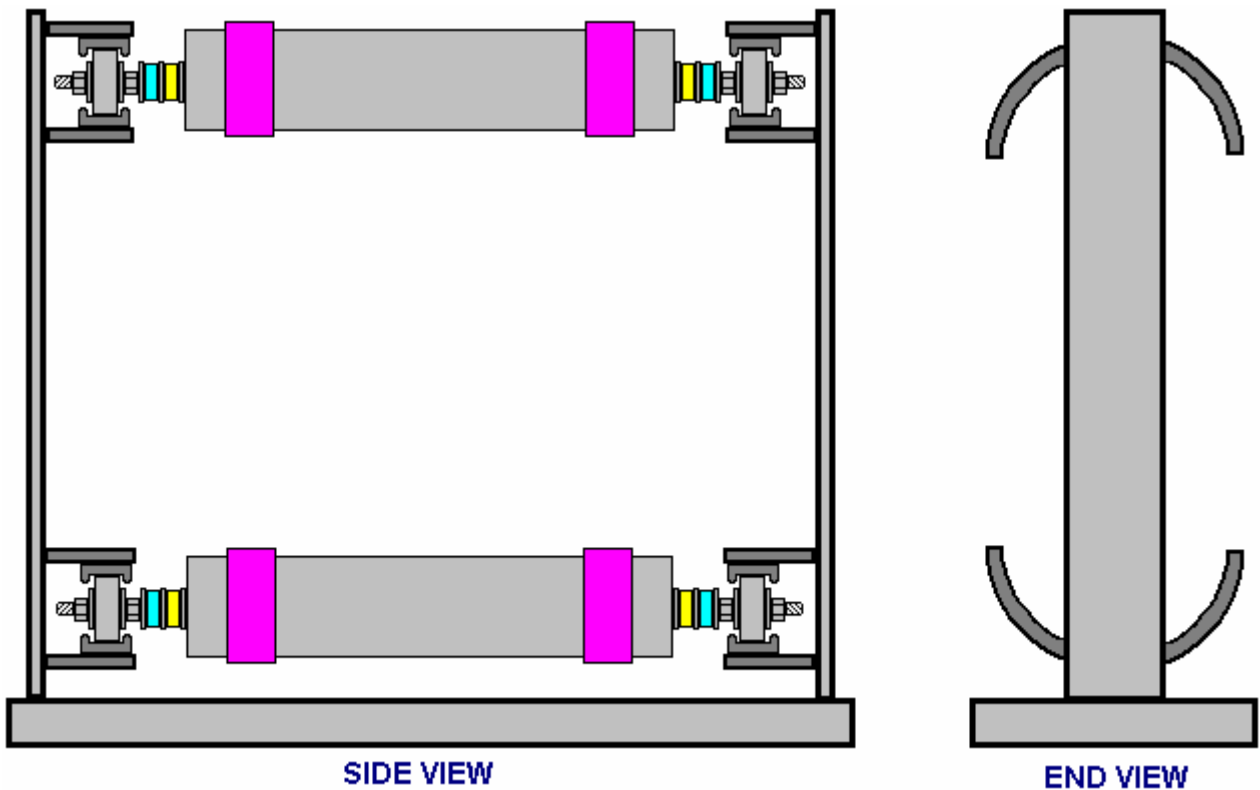

This method provides a low-friction channel for the roller-bearings to move along. This controls the position of the weights very accurately and the end walls also provide the supports for the axles which synchronise the positions of the weights and provide gearing between the axles if that is required. For clarity, just two of the many weights are shown and the overall proportions distorted so that the diagram will fit on the page.

With the axles, it might look like this:

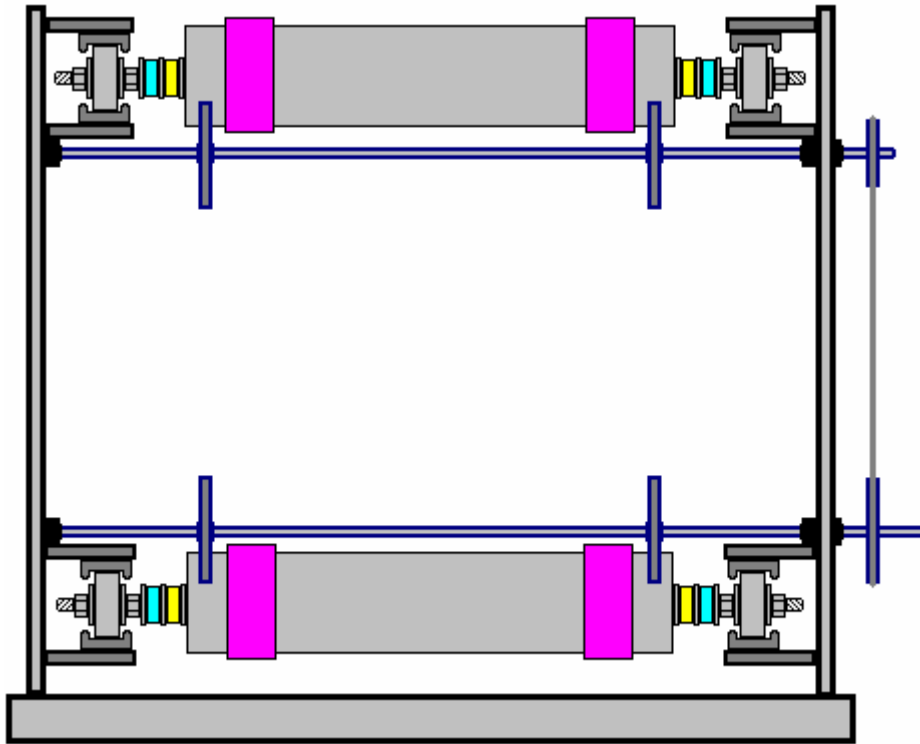

Here, the axle shafts are geared together outside the end wall and either a chain or a belt drive used. The lower shaft allows a power take-off. The ratio of the diameters of the pulley wheels or sprocket wheels dictates the relative rates of rotation of the two shafts.

Other Gravity-Powered Designs.

Sterling Allan reports on **Bobby Amarasingam's** design which has 12 kilowatts of excess power: http://pesn.com/2010/12/04/9501738_British_gravity_motor_generates_12_kilowatts/

Also reported by Sterling is the **Smith-Caggiano** gravity/momentum/centrifugal-force generator design. The report is at: http://www.peswiki.com/index.php/Directory:OBM-Global%27s_Angular_Force_Generator

Another of Sterling's reports is on the **Chalkalis Gravity Wheel** which can be seen at: http://peswiki.com/index.php/OS:F._M._Chalkalis_Gravity_Wheel

Buoyancy

While we are aware of buoyancy being used to convert wave power into electricity, we seem to neglect the idea of using the very powerful buoyancy forces (caused by gravity) as a direct tool at locations away from the sea. This is definitely a mistake because serious levels of power can be generated from such a system. One such system is:

The "Hidro" Self-Powered Generator of James Kwok.

This design demonstrates yet again, the practical nature of drawing large quantities of energy from the local environment. Commercial versions are offered in three standard sizes: 50 kilowatt, 250 kilowatt and 1 megawatt and licensing partners are being sought. This generator which James has designed can be seen at the Panacea-bocaf.org web site at <http://panacea-bocaf.org/hidrofreeenergysystem.htm> and on James' own web site at <http://www.hidroonline.com/> both of which have video clips explaining how the design works. The method is based on different pressures at different depths of water, gravity, and on the buoyancy of air-

filled containers. The system does not rely on wind, weather, sunlight, fuel of any type, and it can operate all the time, day or night, without causing any kind of pollution or hazard. This particular design calls for a water-filled structure of some height, a source of compressed air and a pulley system, and without wishing to be in any way critical, it seems rather more complicated than it needs to be. If, unlike James, you have not done the mathematics for the system, you would assume that the amount of power generated by a system like this would be less than the amount of power needed to make it operate. However, that is definitely very far from reality as considerable excess power is gained through the natural forces of the local environment which make the system operate. Part of the patent application which James made is shown here:

US 2010/0307149 A1

Date: 9th Dec. 2010

Inventor: James Kwok

HYDRODYNAMIC ENERGY GENERATION SYSTEM

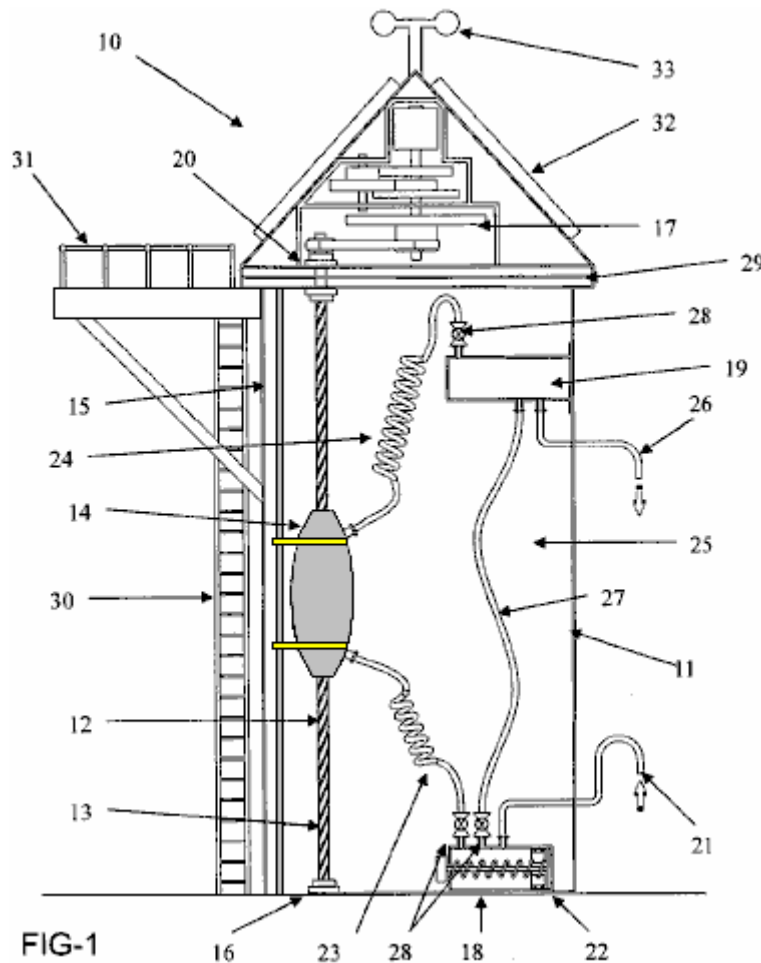

Fig.1 is a cross-sectional view of an embodiment of the energy generation system of the present invention. Here, the energy generation system **10** comprises a vessel **11** in the form of a water tank and a shaft **12** which can rotate about its longitudinal axis. The shaft **12** is provided with a helical screw groove **13** and is connected at its lower end to a bearing **16** which allows it to rotate freely about its longitudinal axis.

The upper end of the shaft is connected to a generator **17** which is a flywheel system. The rotational energy of shaft **12** may be transferred to the generator through a ratchet-cog system **20**. A buoyant inflatable capsule **14** is provided along with its guiding mechanism **15** which is in the form of a wire or pole to assist in the smooth vertical movement of buoy **14**.

There is a first air reservoir **18** located in a lower portion of the vessel **11** and a second air reservoir **19** located in an upper portion of the vessel **11**. The first reservoir **18** draws air from the atmosphere, in through air intake port **21**. Once the pressure in the first reservoir has reached a predetermined value, a piston **22** is actuated, forcing air through hose **23** into the buoyant capsule **14**, which, when inflated, begins to move upwards through water tank **11**, as the buoy **14** has become less dense than the fluid **25** (such as fresh

water or saltwater) in tank 11. This in turn causes rotation of shaft 12, and activation of the power generator 17, thereby generating power.

When buoy 14 reaches the upper limit of its travel, the air in the buoy may be forced to flow through a second hose 24 and into the second air reservoir 19. When air is removed from the buoy it moves downwards through vessel 11 under gravity and with the assistance of ballast (not shown). The downward movement of buoy 14, causes rotation of the shaft 12, which drives the generator 17, thereby generating power.

Air stored in the second reservoir 19 may be vented to the atmosphere through a vent 26 if the pressure in the second reservoir 19 becomes too high. Alternatively, air may flow from the second reservoir 19 into the first reservoir 18 through a third hose 27 so that less air must be drawn into the first reservoir 18 when buoy 14 reaches the lower limit of its travel and must once again be inflated with air from the first reservoir 18.

The hoses 23, 24 and 27 are provided with non-return valves 28 to ensure that air will flow in only one direction through the system 10. Vessel 11 may be provided with ventilation 29 as required and it may also be provided with access stairs 30 and an access platform 31 so that maintenance may be carried out as required. The system may also be provided with a solar energy collection device 32 to generate at least a portion of the energy required to drive piston 22 and the non-return valves 28. Energy produced by the solar energy collection device 32 may also be used to power a light or beacon 33 to indicate the location of the system 10.

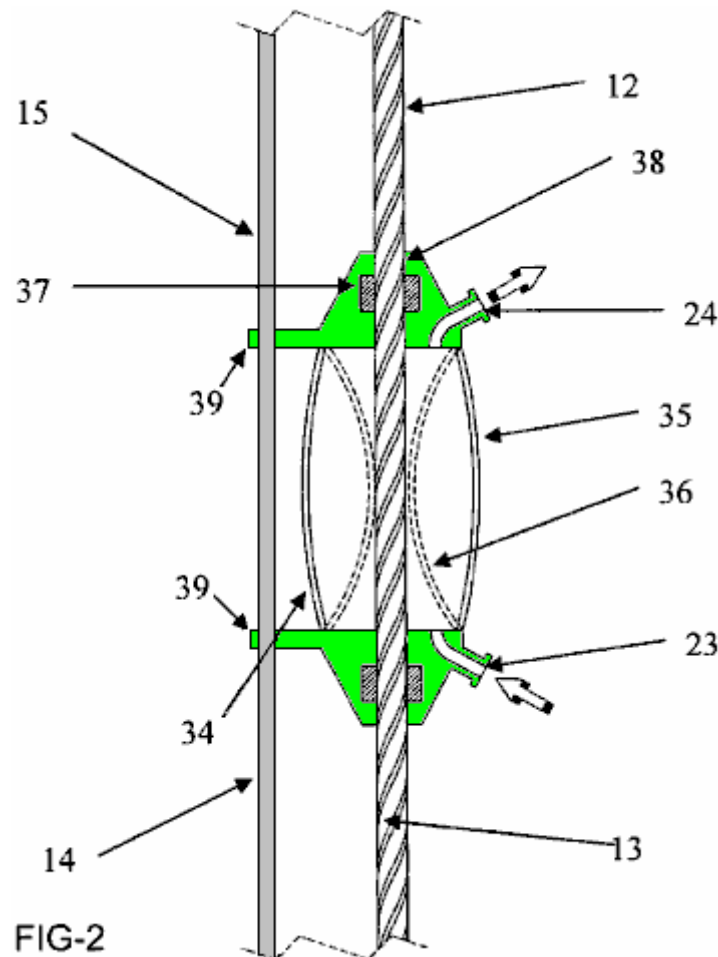

Fig.2 shows one arrangement for buoy 14 comprising an inflatable capsule 34. This figure illustrates the shape of the walls of the inflatable capsule 34 when inflated 35 and when deflated 36. Air passes into capsule 34 through hose 23 and exits from the capsule through hose 24.

The buoy 14 also has a sleeve 37 attached to it. This sleeve has projections which engage with the helical groove 13 of shaft 12, thereby causing rotation of the shaft when the buoy moves relative to shaft 12. Sleeve 37 is provided with ballast 38, such as stainless steel weights that assist in the downward movement of the buoy when it is deflated.

Buoy 14 is attached to a guide pole 15 and the buoy has a pair of arms 39 which slide on the guiding pole 15 and assist in the smooth vertical movement of the buoy.

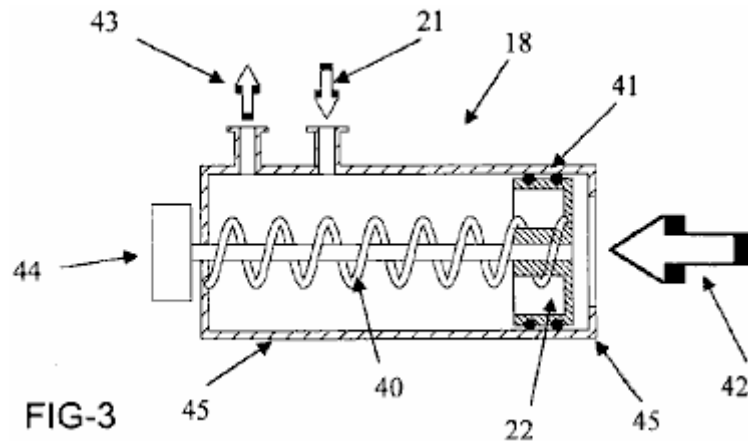
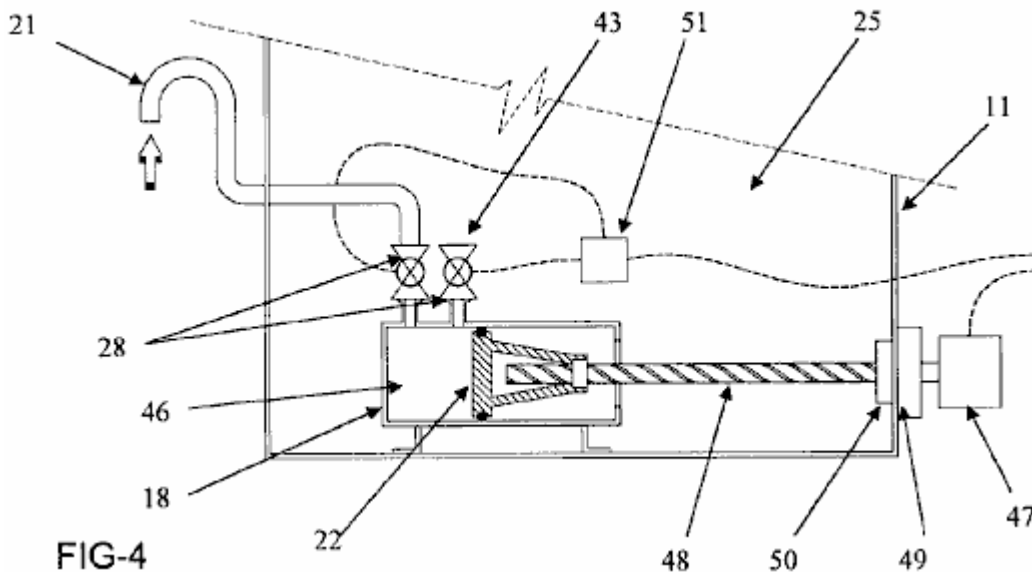

Fig.3 shows one version of the first air reservoir 18. Air is drawn into reservoir 18 through air intake 21. The reservoir includes a piston 22 associated with a spring 40, the piston 22 being provided with seals 41 to prevent leakage of air.

When pressure, such as hydrostatic pressure, is applied in the direction of arrow 42, the piston moves to the left of the reservoir 18 compressing spring 40 and forcing air out through outlet 43. A motor 44 is provided to reverse the movement of the piston 22. Reservoir 18 may be fixed to the floor of the vessel.



An alternative construction of the first air reservoir 18 is shown in **Fig.4**. In this embodiment, reservoir 18 is housed within a vessel 11 containing a fluid 25. Air enters reservoir 18 through air intake 21 and is held in a chamber 46. The reservoir has a piston 22 and the movement of the piston 22 towards the left of the reservoir 18 forces air in the chamber 46 out through air outlet 43.

Piston 22 is driven by motor 47 which rotates the helically-grooved shaft 48. The motor is linked to the shaft by a ratchet and cog mechanism 49, which is provided with a spring loaded seal 50 on the inner surface of vessel 11. An actuator 51, may be used to control the opening and closing of non-return valves 28 as well as the actuation of motor 47.

Fig.5 illustrates a cross-sectional view of an energy generation system according to one of the embodiments of the present invention:

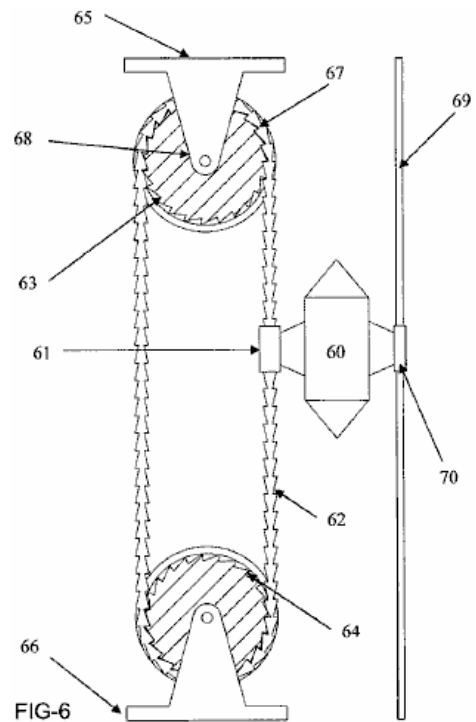
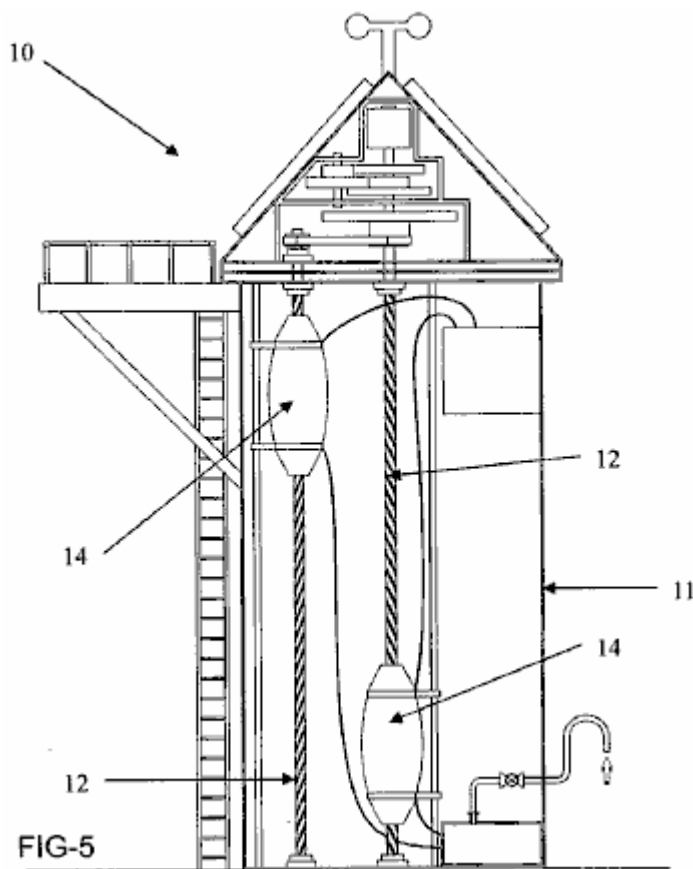

Fig.5 shows an embodiment where which a pair of buoys **14** are present. Each buoy is associated with its own shaft **12** and may move up and down inside vessel **11** independent of one another.

In **Fig.6**, an alternative embodiment of the present invention is illustrated, where the buoy **60** has a connecting method **61** in the form of a cylindrical sleeve through which a guide chain **62** passes. Chain **62** is provided in an endless loop and is located on an upper tracking device **63** and a lower tracking device **64**, both of which are pulleys. The upper pulley **63** may be fixed to an upper wall (not shown) of a vessel (not shown) via a bracket **65**, while the lower pulley **64** may be fixed to a lower wall (not shown) of a vessel (not shown) via a bracket **66**.

The connection mechanism **61** contains ratchets which engage with the links of the chain **62** when buoy **60** moves downwards. Thus, as buoy **60** moves downwards, chain **62** also moves, thereby causing both the upper and lower pulleys to rotate in a clockwise direction. The upper and lower **64** pulleys have a series of indentations **67** corresponding to the shape of the links of the chain **62**. In this way, the chain **62** sits in the indentations **67** and grips the tracking device (**63, 64**), thereby ensuring that the tracking device (**63, 64**) rotates.

In the embodiment of the invention illustrated in **Fig.6**, a work shaft **68** is associated with the upper pulley **63** such that rotation of the upper pulley results in rotation of the work shaft **68**. The work shaft **68** is located substantially perpendicular to the direction of travel of the buoy **60**. The work shaft drives a generator to produce power.

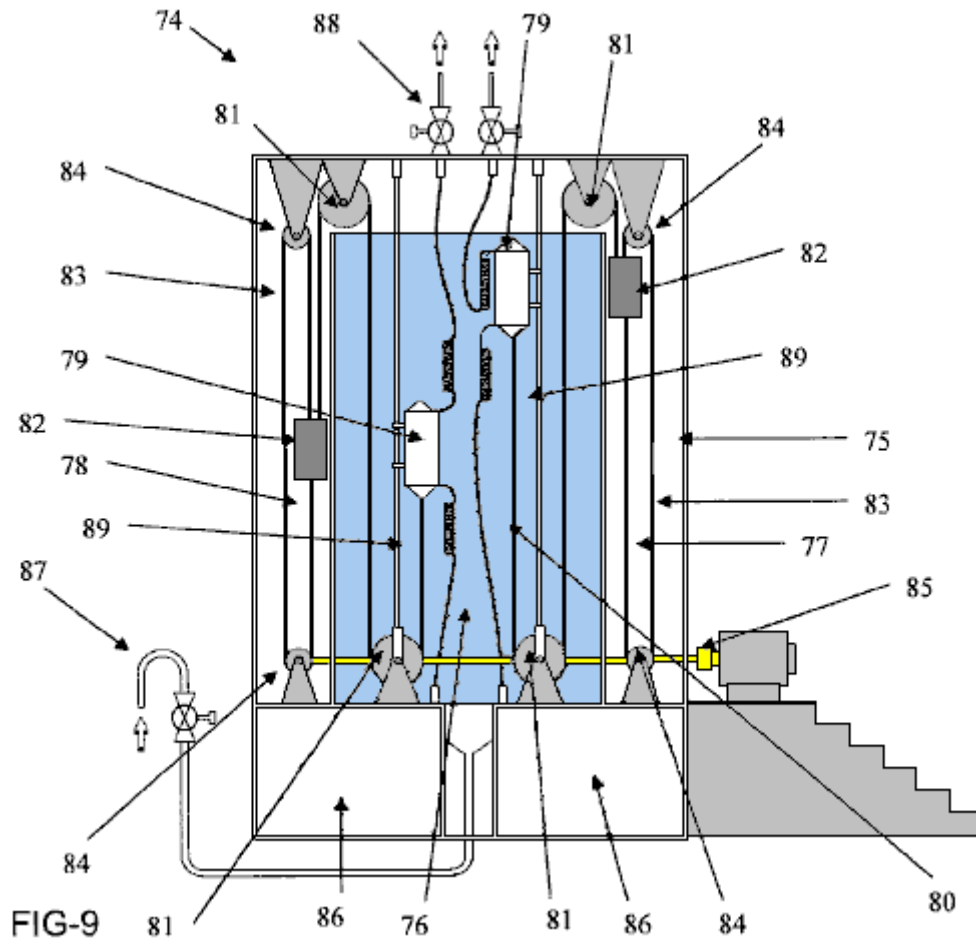

Fig.9 shows an alternative embodiment of this energy generation system **74**. The system is comprised of a vessel **75** having a fluid-filled “wet” compartment **76** and one or more “dry” compartments (in this case, a pair of dry compartments **77, 78**) with no liquid in them. These dry compartments may be fabricated from any suitable material, such as, concrete, steel, fibreglass, plastic or any combination of materials.

The system also has a pair of buoys **79** each with a deflatable bladder-like construction. The buoys have guide rails **89** which ensure that the buoys move smoothly up and down inside the vessel **75**.

In this embodiment of the invention, air reservoirs **86** are located in the base of the vessel **75**. Air enters the reservoirs **86** through inlet **87**, while air exiting from the buoy **79** is vented through valves **88**. The vented air may either be expelled to the atmosphere or recycled to the reservoirs **86**.

Each of the buoys is designed to be connected to one end of a chain or rope **80**. A weight **82** is connected to the other end of the chain or rope **80**. The chain or rope **80** has a series of pulleys **81** such that when the buoy is inflated and filled with air, the buoyancy is greater than the weight **82** and so the buoy rises in the vessel.

When the buoy **79** is deflated, weight **82** is heavier than the buoyancy and so the buoy sinks in vessel **75**. In the embodiment illustrated here, the weights **82** are located in the dry compartments **77,78**. There are several reasons for this, including that, by locating the weights **82** in the dry compartments **77,78**, the velocity of the weights **82** in the downward direction is increased, and therefore an increase in the energy produced by the system **74** is experienced.

The weights **82** are associated with second ropes or chains **83**, such that vertical movement of the weights **82** results in the rotation of the second ropes or chains **83** around a pair of sprockets **84**. Rotational energy generated by the rotation of the second ropes or chains **83** is transferred to a power generation device **85** (such as a turbine or the like) in order to generate power (e.g. electrical power)

In spite of its mechanical complexity, the Hidro design is offered as a commercial generator with tens of kilowatts of excess power, indicating that buoyancy is a significant method of generating power, based on the fact that water is hundreds of times heavier than air. Due to its weight, movement in water is slow but can be very powerful. The helical groove method of converting the vertical movement of the floats into rotational power is used because of this as it has a very high ratio between shaft turns and movement along the shaft. This can be understood when you consider the fact that a complete revolution of the shaft is caused by the float moving up just one step to the next thread position directly above. The turns ratio for the complete float movement is determined by the angle of the groove cut into the drive shaft.

One other thing which needs to be considered for such a project is the weight of the overall structure when filled with water. The overall weight is liable to be many tons and so the footing underneath the generator needs to be very robust. Also, while compressed air is mentioned, giving the impression of cylinders of compressed air or gas, For continuous operation one would expect an air pump to be used. Whether or not an air pump is used, the diameter of the air hoses needs to be considered. Most people think that a gas can flow along a pipe or tube very easily. That is not the case. If you want to get a feel for the constriction caused by a pipe, then take a one metre length of 6 mm diameter plastic tube and try blowing through it. No significant amount of air will pass through the tube even if you blow very hard. The web site http://www.engineeringtoolbox.com/natural-gas-pipe-sizing-d_826.html shows this table:

Capacity of Pipe (MBH ≈ CFH)							
Pipe Size (inches)		Pipe Length (feet)					
Nominal	Inside diameter	10	20	40	80	150	300
1/2	0.622	120	85	60	42	31	22
3/4	0.824	272	192	136	96	70	50
1	1.049	547	387	273	193	141	100
1 1/4	1.380	1200	849	600	424	310	219
1 1/2	1.610	1860	1316	930	658	480	340
2	2.067	3759	2658	1880	1330	971	686
2 1/2	2.469	6169	4362	3084	2189	1593	1126
3	3.068	11225	7938	5613	3969	2898	2049
4	4.026	23479	16602	11740	8301	6062	4287
5	5.047	42945	30367	21473	15183	11088	7841
6	6.065	69671	49265	34836	24632	17989	12720
8	7.981	141832	100290	70916	50145	36621	25895

Notice the major difference in carrying capacity of any of these pipes with just the change from a 10-foot (3 metre) length to a modest 20-foot (6 Metre) length, and those lengths are the sort of lengths needed for many applications. Also, look at the figures for, say, the 0.5 inch (nominal) diameter pipe. With just a 10-foot length, it would take a full two minutes to pump just one cubic foot of air through it. It follows then, that pipes of considerably larger diameter are needed for a project like the 'Hidro'.

It is possible to construct a much more simple version of the 'Hidro', perhaps like this:

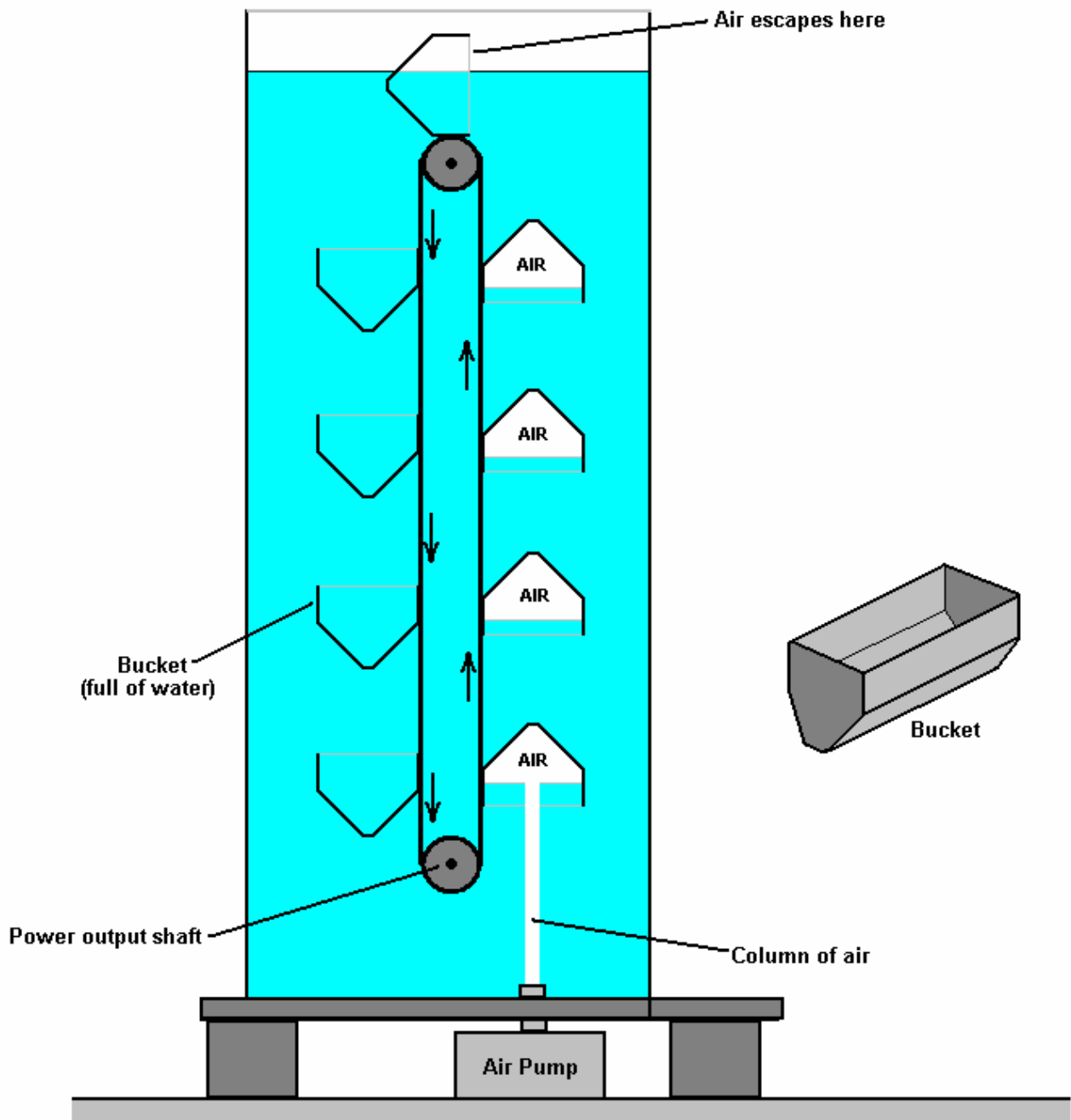

A simple hydraulic, buoyancy-powered generator can be constructed, with two or more horizontal, rotating shafts submerged in water in such a way that they are effectively positioned one above the other. Each shaft has one, and preferably two or more sprocket wheels mounted on it. Each of these sprocket wheels engages with a continuous chain loop which also engages with the sprocket wheel which is positioned vertically above it. These vertical chain loops form a belt-style support for a series of identical buckets. On one side of the vertical belt the buckets have their open face upwards and on the other side the bucket openings are facing downwards. An air pump is positioned directly underneath the set of buckets which have the bucket openings facing downwards. The air pump generates an upward-moving stream of air which collects in the rising buckets, displacing the water filling the bucket. This results in a powerful upward thrust caused by the buoyancy of that bucket, and the thrust causes the bucket to move upwards, rotating both horizontal shafts and bringing another water-filled bucket into position above the air pump. A gearing system transfers the rotation torque thus produced, to a generator which produces electricity for general purpose uses.

This is a generator whose input shaft is rotated through buoyancy caused by air-filled containers submerged in a tank of water or some other suitable heavy liquid. Continuous, powerful rotation of the generator shaft is produced through the use of one or more conventional, commercially available air pumps. An air pump is used to fill a series of containers which are open at one end and which are attached to what is effectively a belt arrangement created by two strong chain-link loops which mesh with sprocket wheels mounted on two

shafts, either, or both of which can be utilised for the extraction of useful power, preferably for driving an electricity generator but not necessarily limited to that function as any powerful torque has many useful applications.

Objectives are to provide a power generation system which is very simple in form and which can be understood, operated and maintained by people with minimal training. Also, a system which uses components which are already readily available, thus avoiding significant manufacturing costs, and one which operates without the need for any kind of complex mechanism or high-precision equipment and which can operate with a wide range of commercially available products.

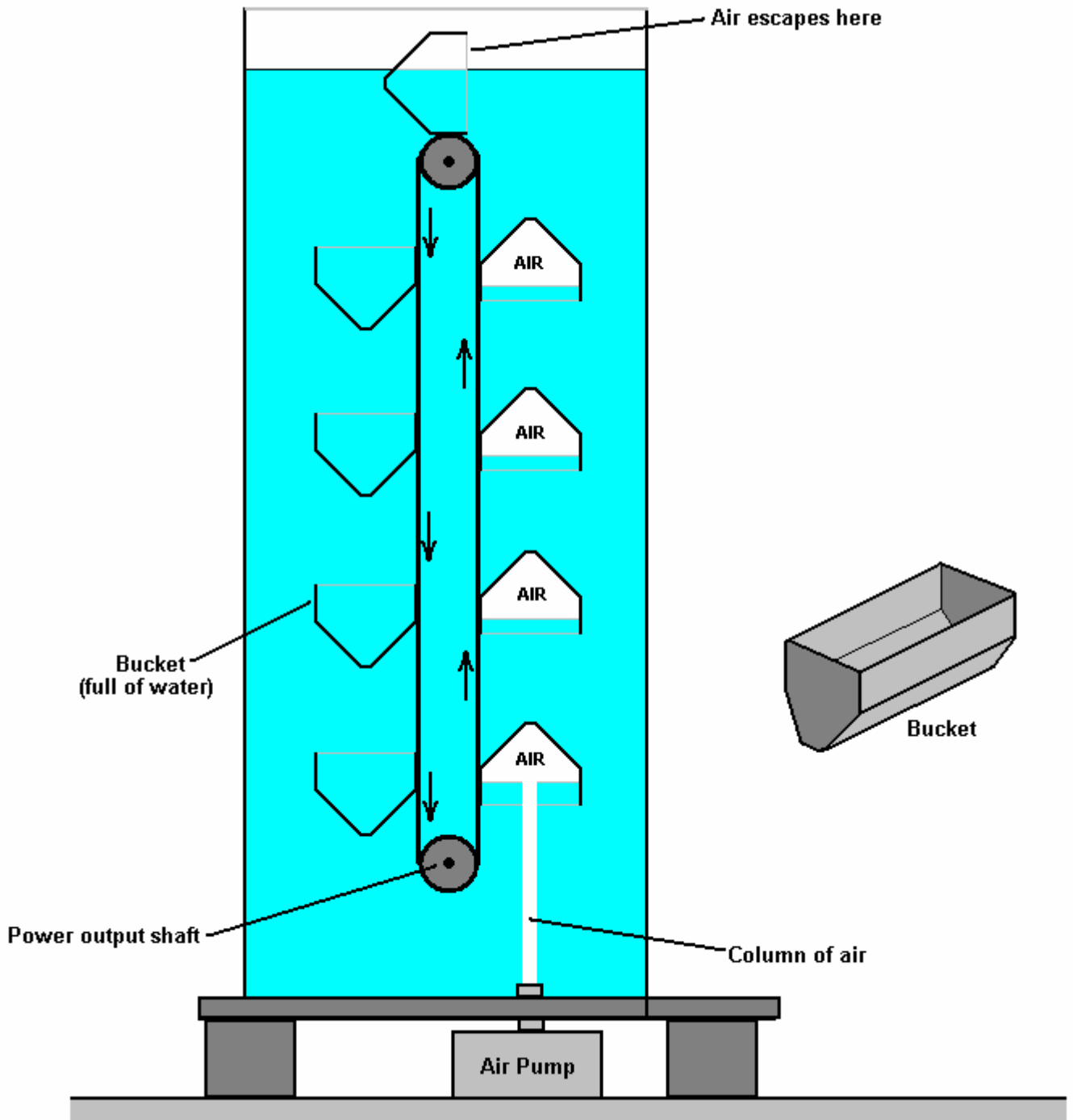

Fig.1, is a simplified partial schematic cross-sectional view showing the main components of the generator as seen from one end.

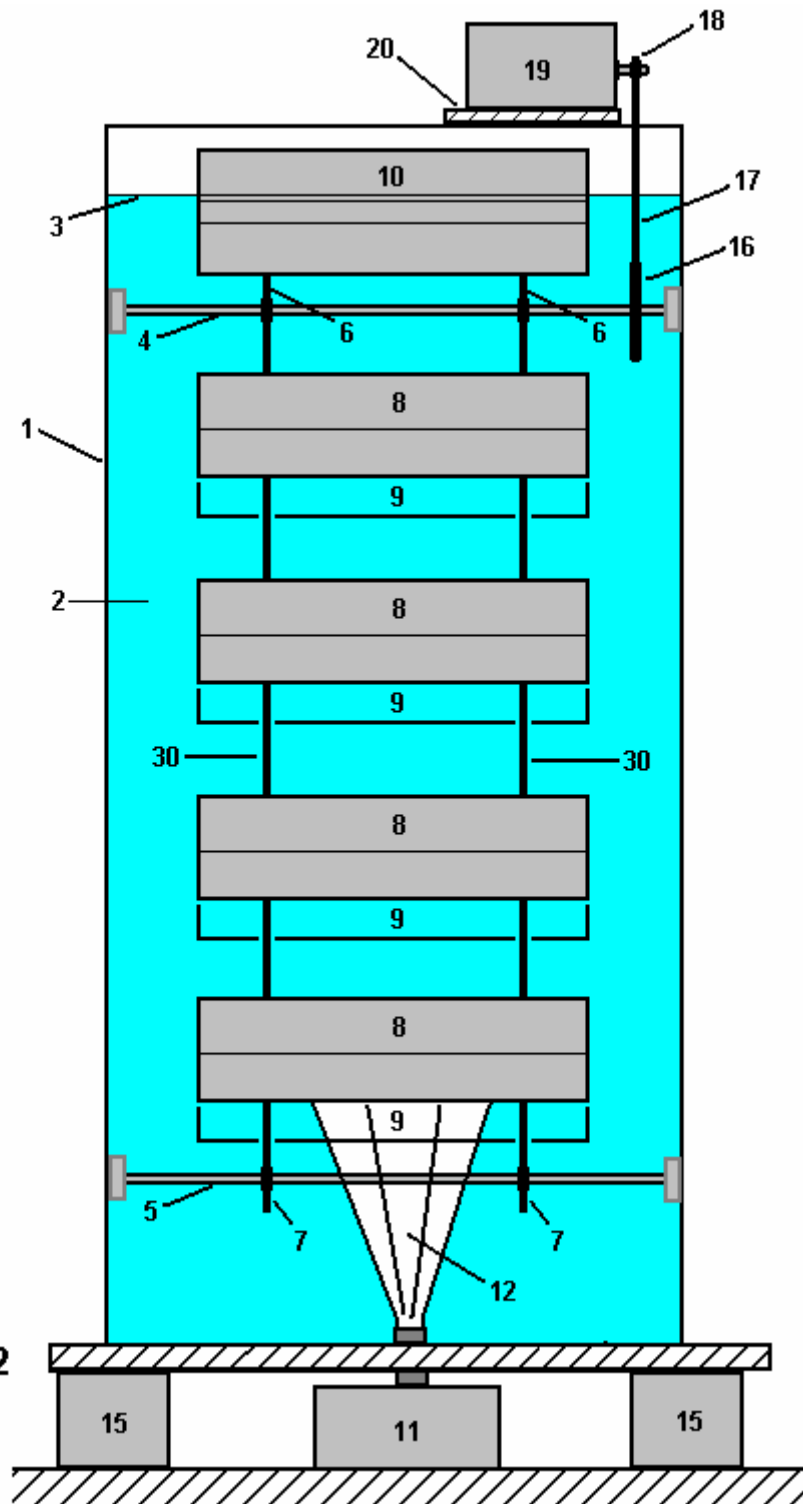

Fig.2

is a cross-sectional conceptual schematic view showing the frontal aspect of the generator in its most simple form.

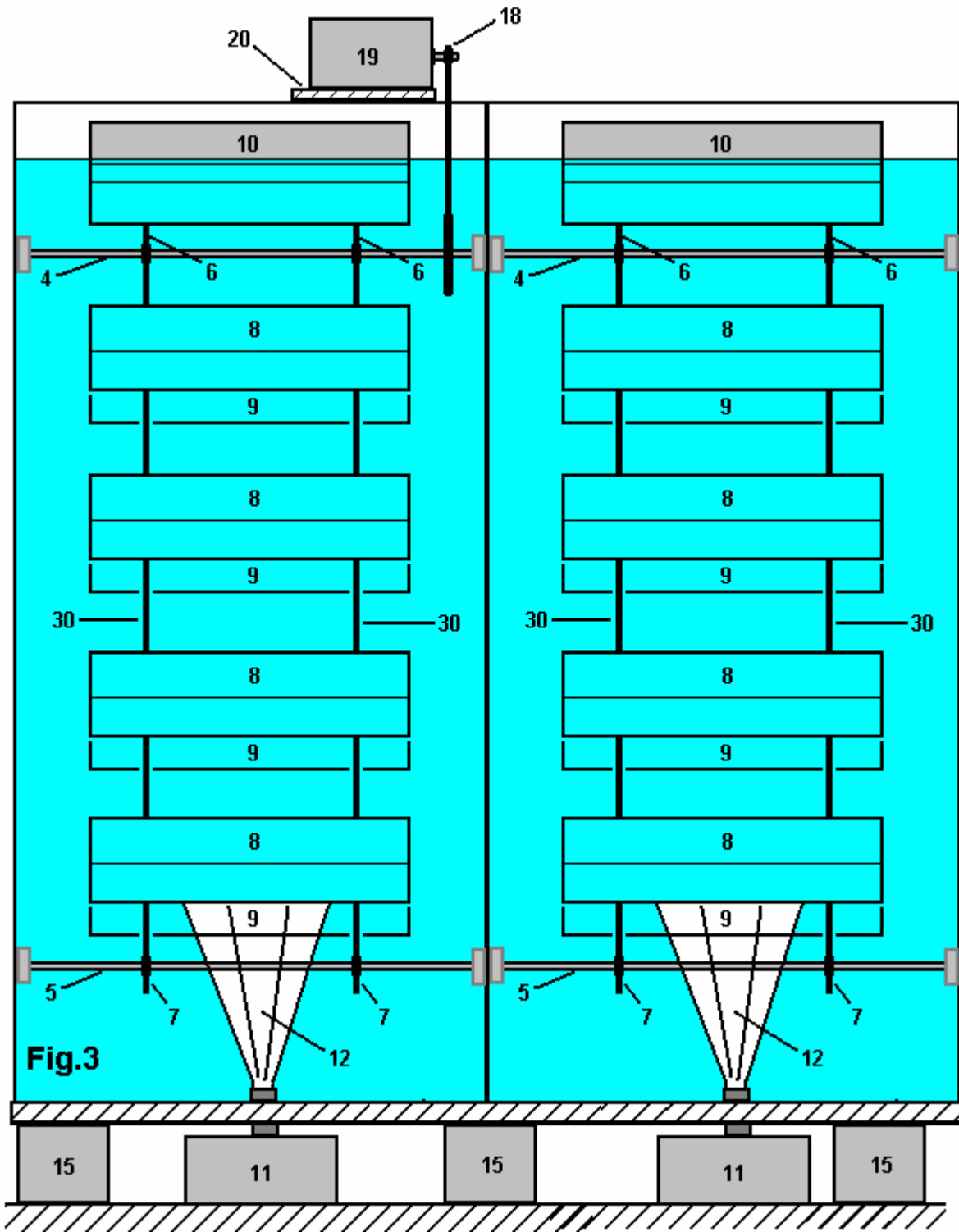

Fig.3, is a cross-sectional conceptual schematic view showing the frontal aspect of the generator where more than one set of buckets is used.

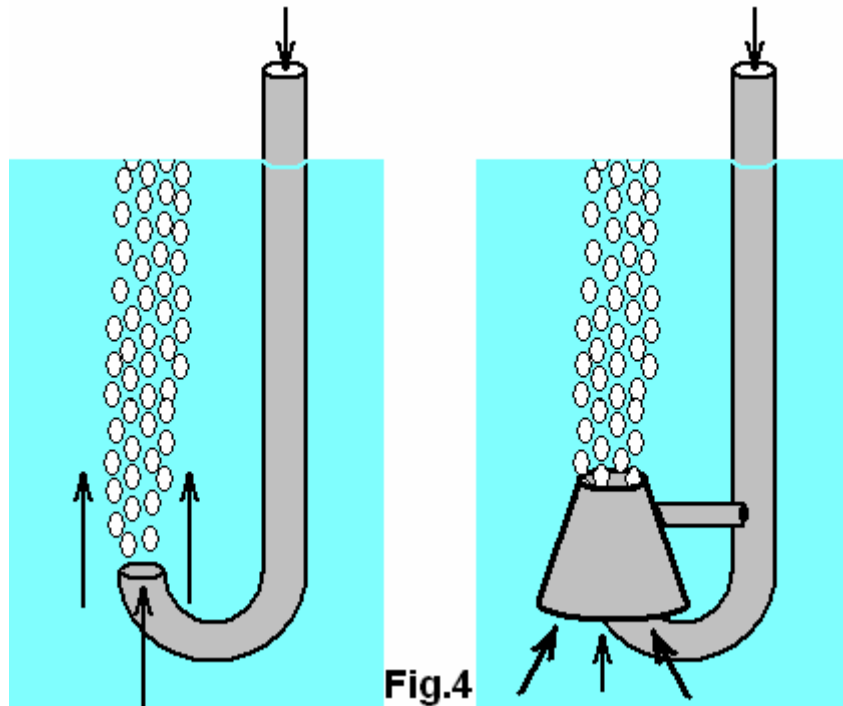

Fig.4

Fig.4, is a perspective conceptual view showing arrangements for a simplified air-feed system which operates from above the tank.

Fig.1, illustrates the overall concept of the generator in its most simple form where lightweight rigid buckets are used to capture the rising air from the air pump. In this Figure, a water tank **1**, holds water or other suitable liquid **2**. The surface of the liquid **3**, is indicated to illustrate the fact that a bucket **10**, which is in the process of turning over at the top of its orbital motion, is positioned so that one edge of the bucket is clear of the surface of the water, which allows the air which was trapped inside the bucket to escape into the atmosphere and the water fill the entire bucket causing only a very minor turbulence when doing so. This is a desirable, but not essential feature as the air trapped in any bucket will escape upwards as soon as the bucket starts its downward movement, positioning its open end upwards, although this causes unnecessary turbulence inside the tank. One possible bucket shape is shown in perspective view, but many different bucket shapes may be used, including flexible membrane types or alternatively, hinged-plate types which have very much reduced resistance to moving through the water when in their collapsed state during their downward movement.

The buckets **8**, **9** and **10**, are attached to two strong chains **30**, which mesh with the upper sprocket wheel **6**, mounted on the upper axle **4**, and the lower sprocket wheel **7**, which is mounted on the lower axle **5**. Although it is not visible in **Fig.1**, there are two upper sprocket wheels **6**, two lower sprocket wheels **7**, and two chain loops **30**, although these can be seen in **Fig.2**.

The tank is supported on a robust plate **14**, which itself is supported by a series of pillars **15** which rest on a secure footing **16**, providing operating space underneath the tank for the installation and maintenance of the air pumping equipment. As fresh water weighs 1000 Kg per cubic metre, the weight of the operational generator system is substantial and so this must be allowed for when assessing the footing needed to support the tank and it's contents. While a thin-wall tank is shown in **Fig.1**, many different forms of tank may be utilised, including earth bank and plastic membrane styles, or resurfaced abandoned well shafts. The tank of **Fig.1** presumes that the lower axle **5** is taken out through the wall of tank **1**, using an arrangement similar to that used for the drive shafts which power the screws of ships and other power vessels. While an arrangement of that type provides a drive shaft which is conveniently close to the ground, the much more simple arrangement shown in **Fig.2** where the output power is taken off using the very simple chain and sprocket wheel method utilised for the bucket supports (chain **30**, and sprocket wheels **6** and **7**). In general, the more simple and straightforward any design is, the better it works in practice and the lower any maintenance costs become.

Referring again to **Fig.1**, when activated, air pump **11** produces a stream of air **12**, which flows rapidly upwards. This stream of air **12**, once established, does not have to push against the head of water as immediately above the nozzle of the pump is a rapidly rising column of air, sustained both by the exit velocity from pump **11** and the natural upward movement caused by the relative weights of water and air (as water is

several hundred times heavier than air). This column of air would normally flow straight upwards in calm water, but should it be found that turbulence in the water tends to push the rising air away from its vertical path, baffles can be placed around the pump and positioned so that the air stream is forced to stay within the same section of water taken up by the rising buckets.

The rising air enters the lowest of the rising buckets and collects in it, forcing the water out of the open bottom of the bucket. If the rising bucket is not completely filled with air before the next bucket moves between it and the air pump, the trapped air will expand as the bucket rises and the water pressure reduces due to the lesser depth. Any one bucket with a substantial amount of air in it will create a very significant upward force due to buoyancy, air being about one thousand times lighter than water.

Each bucket on the rising side adds to that upward force and consequently, the chains **30** need considerable strength. The weight of the buckets on each side of the chain match and so the main advantage of light buckets is to lower the inertial mass of the moving parts. Movement through the water is relatively slow but this is offset by gearing between the output drive shaft and the generator's input shaft. The power of the system can be increased by adding more buckets in the vertical chain, increasing the water depth accordingly. Other ways of increasing the power include increasing the volume inside each bucket and/or increasing the flow rate produced by the air pump or pumps used. Another simple method is shown in **Fig.3** and discussed below. An alternative to air pumps is to use tanks of a compressed, non-polluting gas, possibly air.

The buckets shown in the various Figures are rigid, very simple shapes, possibly made by a plastic moulding process in order to be cheap, strong, lightweight and permanently water-resistant. There are, of course, many possible variations on this including using rigid hinged plates sealed with a strong flexible membrane, allowing the buckets to fold and become streamlined on their downward path, and opening as soon as they turn to start their upward movement. There are many mechanisms which can provide this movement, but it is a matter of opinion as to whether or not the extreme simplicity of rigid buckets is worth sacrificing

Fig.2 shows a schematic layout of the generator when seen from the side. The same numbers apply to the components already seen in **Fig.1**. The arrangement seen in **Fig.2** is the most simple, basic, single bucket set. The near-side rising buckets **8** obscure the view of the far-side falling buckets **9** and only the lowest part of the falling buckets **9** can be seen in this view. **Fig.1** shows buckets which are some two and a half times longer than they are wide, but this, of course, is just one option among literally thousands of possible proportions. The size and shape of buckets is related to the performance and number of air pumps being used for any one set of buckets and that choice depends on what is available locally at a reasonable price. It would not be unusual for two or three air pumps to be used side by side along the length of the bucket **8** although **Fig.2** only shows a single pump.

Fig.2 also shows a simple method for power take off where a large diameter sprocket wheel **16** is mounted on the upper axle **4**, and driving a much smaller diameter sprocket wheel **18** which is mounted on the drive shaft of the electricity generator **19** which is mounted on plate **20** which is attached securely to the top of tank **1**.

Fig.3 shows one of the possible arrangements for increasing the system power without increasing the depth of water used. Here, the axles **4** and **5** extend far enough to allow another set of buckets to drive them, increasing the torque very substantially. While **Fig.3** shows one extra set of buckets, there is, of course, no reason why there should not be three or more sets of buckets side by side. It should be noted however, that the partitions shown between the bucket sets are not there just to reduce the water swirling but are needed to support the bearings which are essential for the extended axles, since without those, the diameter of the bars used for the axles would have to increase very markedly to avoid unwanted flexing along their length. While the second set of buckets has been shown aligned exactly with the first set, there is an advantage in offsetting them relative to each other so that the output torque is more even with buckets emptying and filling at different points in the bucket cycle.

Fig.4. shows a method for further simplification, where the air is pumped from above the water surface. It is a matter of concern to most people, that the pressure of the head of water above the air pump is a major obstacle to overcome and will be a continuous opposing force during operation of the generator. If air is being injected from underneath the tank, then initially, that pressure head has to be overcome. However, once the air flow is established, a vertical cigar-shaped area of water vortex is established by the rising air stream. This three-dimensional annular vortex negates the water head in the small area immediately above the air nozzle, and almost sucks the air out of the pump, after the initial introduction of the air has been accomplished.

There is another way of achieving this desirable effect without ever having to pump against the total head of water, and that is to use a mobile air pipe as shown in **Fig.4**. Initially, the air pump is started and lowered a short distance into the water. The opposing head of water is not large and the water vortex can be established quite easily. The pipe is then lowered very slowly, so as to maintain the vortex at a progressively lower depth, where, in spite of the increased head of water, the pump does not have to overcome that head. When the pipe outlet reaches the operational depth, it is then rotated to bring it under the set of rising buckets. The major advantage of this arrangement is that the tank is as simple as possible, with no possibility of leaking, and so abandoned wells can be modified to become energy generators. Alternatively, an earth bank can be erected to form an above-ground tank, possibly sealed with a plastic membrane. This method also avoids needing to support the weight of tank and water above a work-area where the air pump or compressed-air cylinders are located and maintained. The creation of the water vortex can be assisted by the addition of a cowl around the pipe exit as shown in this figure, but that is an optional feature.

The Ribero Buoyancy Patent.

While internal combustion engine demonstrate that considerable power can be had from motion which moves backwards and forwards continuously, that sort of action is not very efficient as there is continuous reversal of the oscillating drive components. The floats in the (very successful) 'Hidro' design shown above. A different design is shown in the 2011 patent of Renato Bastos Ribero of Brazil. Here is an excerpt from that patent:

US 7,958,726

14th June 2011

Inventor: Renato Bastos Ribero

Apparatus and associated methods to generate useable energy

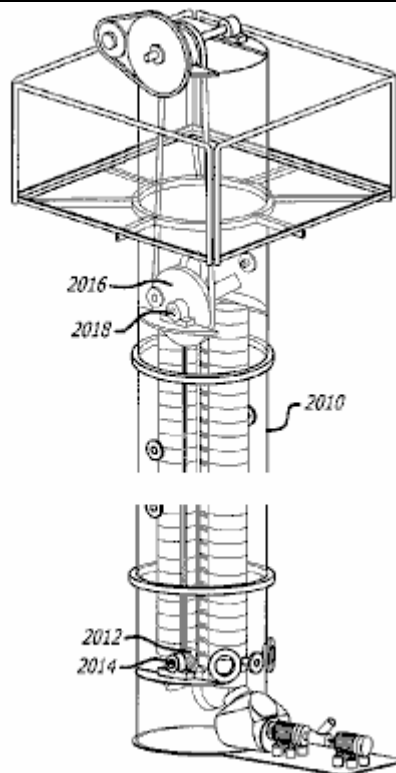

Abstract:

The present disclosure relates to an apparatus and associated methods for generating energy by capturing and taking benefit of the energy generated by any quantity of air surfacing inside water. In exemplary embodiments, the apparatus comprises compressing a lower density gas in a liquid medium, allowing the gas to naturally rise to the surface of the liquid medium and then capturing the energy generated by the surfacing gas.

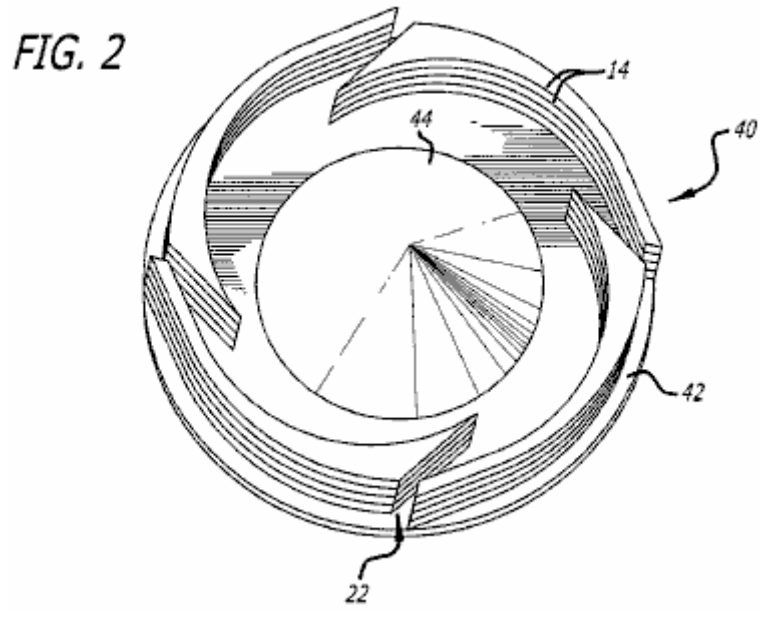
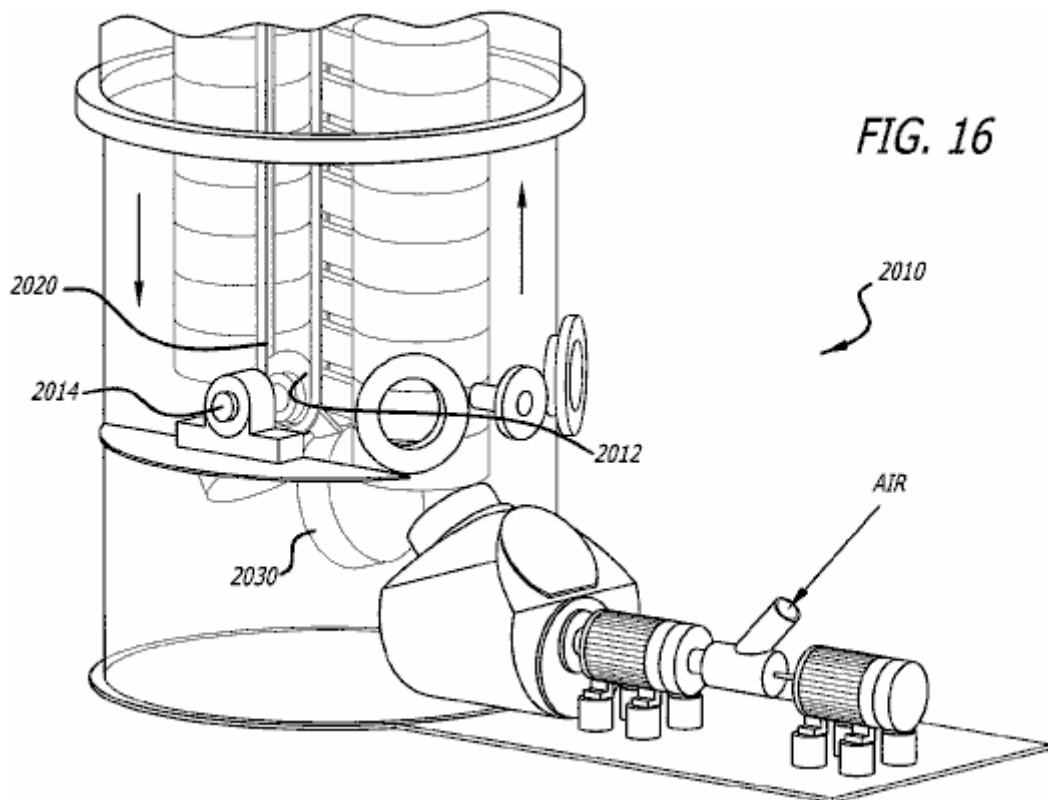

Fig.2 is a perspective upper view of a rotor disc for compressing a gas into a liquid medium. This disclosure is in two stages which, in this case, work together. The first stage consists of the creation of energy with the introduction of air at the bottom part of a water column. Once introduced, the air creates energy when moving towards the surface. The introduction of air into the water is the main point of this first part of the disclosure. A method was created in order to use a very small quantity of energy when doing this.

The teeth on the disc, when rotated in water, water to flow away from the area between the teeth, lowering the pressure there and allowing the easy introduction of air in that area. Without air introduction, water would not move away and the pressure would not be reduced. The purpose of the cone is to spread the incoming air.

The second section of the present disclosure refers to a system with the objective of capturing the air which is inserted at the bottom of a water column or tank, while moving towards the water surface.



As shown in **Fig.16**, buckets **2030** descend on a continuous chain **2020** which passes around a lower and an upper wheel or pulley. On reaching the lower pulley, the buckets turn around the bottom pulley **2014** and line up again on the ascending side of the chain. Immediately after turning around the bottom pulley, each bucket receives the rising airflow.

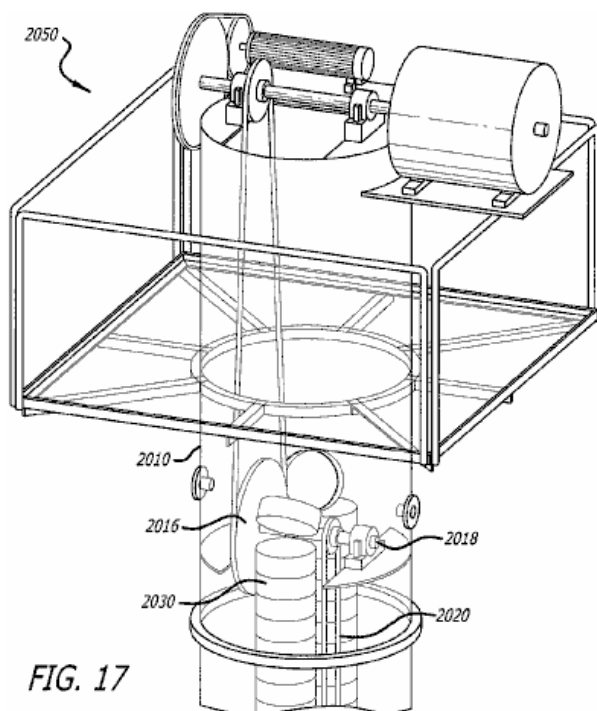

FIG. 17

Fig.17 shows the arrangement at the top of the water tank **2010**. Buckets **2030** rising due to being filled with air, turn over as they pass around the top pulley **2018**, releasing the air inside them and start descending again towards the bottom pulley. The upper axle **2018** has an **estimated** rotational speed of 120 rpm.

In Fig.17 I (Riberio) am showing the transmission of this energy to an axle at the top of the water column where we have a generator **2050** requiring a rotation of 300 rpm plus an engine connected to another generator with rotation of 600 rpm. This part of Fig.17 is only illustrative to show that we **shall** generate energy at the primary axle at 120 rpm, or use any kind of transmission to more convenient rotational speeds.

I think that the words marked in red indicate that although this patent has been granted, the generator has never been built and is only an idea. Personally, I am highly dubious about the mechanisms which are supposed to give reduced water pressure at the air intake, as I don't think that they would work, or if they do, certainly not for the reasons stated. What he wants to do can certainly be done, but not in the way that he suggests. If the axles are rotating at the 120 rpm which he suggests, then that would allow less than one eighth of a second to fill each bucket and while the notion of reduced water turbulence through the buckets touching each other is attractive, I don't think that the method described is feasible.

So, while we can be sure that buoyancy methods are perfectly capable of generating serious power, we need a better design than either of the two shown here as the Hidro appears to be very expensive to build.

Patrick Kelly
<http://www.free-energy-info.co.uk>
<http://www.free-energy-info.com>
<http://www.free-energy-devices.com>
engpjk@free-energy-info.co.uk
engpjk@gmail.com

Chapter 5: Energy-Tapping Pulsed Systems

One very interesting feature of free-energy devices is that although various devices which appear to be completely different and have different apparent applications, the background operation is often the same. It is clear that a sharp positive going DC electric pulse interacts with the surrounding energy field, making large quantities of free-energy available for anyone who has the knowledge of how to gather and use that extra energy.

Let me stress again that "over-unity" is an impossibility. Over-unity suggests that more energy can be taken out of a system than the total energy which goes into the system. This is not possible as you can't have more than 100% of anything. However, there is another perfectly valid way of looking at the operation of any system, and that is to rate the output of the system relative to the amount of energy that the user has to put in to make it work. This is called the "Coefficient Of Performance" or "COP" for short. A COP = 1 is when all of the energy put in by the user is returned as useful output. A COP > 1 is where more useful energy comes out of the device than the user has to put in. For example, a sailing boat in a good breeze transports people along without the need for the energy of movement to be supplied by the crew. The energy comes from the local environment and while the efficiency is low, the COP is greater than 1. What we are looking for here is not something to tap wind energy, wave energy, sunlight energy, river energy, thermal energy or whatever but instead we want something which can tap the invisible energy field which surrounds us all, namely the "zero-point energy" field or the "ambient background".

For this, let us look at pulsing circuits used by a wide range of people in a number of apparently quite different devices. An electrical "pulse" is a sudden voltage rise and fall with very sharply rising and falling voltages. However, pulses are seldom generated as isolated events when working with practical devices, so it is probably better to think of a train of pulses, or a "waveform" with very sharp rising and falling edges. These can be called oscillators or signal generators and are so commonplace that we tend not to give them a second thought, but the really important factors for using an oscillator for zero-point energy pick-up is the quality of the signal. Ideally, what is needed can be a perfect square wave with no overshoot, and the voltage level never going below zero volts, or a complex waveform, also with very sharp attack and decay times. These waveforms are a good deal more difficult to generate than you might imagine.

Even in these days of sophisticated solid-state electronic devices, the best method of creating a really sharp voltage pulse is still considered to be a spark gap, especially one which has the spark chopped off suddenly by the use of a strong magnetic field at right angles to the spark gap. For an example of this style of operation, consider the following device.

Frank Prentice's COP=6 Pulsed Aerial System.

Electrical Engineer Frank Wyatt Prentice of the USA invented what he described as an 'Electrical Power Accumulator' with an output power six times greater than the input power (COP = 6). He was granted a patent in 1923 which says:

My invention relates to improvements in ELECTRICAL POWER ACCUMULATORS and the like, wherein the earth, acting as rotor and the surrounding air as a stator, collects the energy thus generated by the earth rotating on it's axis, utilises it for power and other purposes.

In the development of my WIRELESS TRAIN CONTROL SYSTEM for railways, covered by my United States Letters Patent Number 843,550, I discovered that with an antenna consisting of one wire of suitable diameter supported on insulators, three to six inches above the ground and extending one half mile, more or less in length, the antenna being grounded at one end through a spark gap, and energised at the other end by a high frequency generator of 500 watts input and having a secondary frequency of 500,000 Hz, would produce in the antenna, an oscillatory frequency the same as that of the earth currents and thus electrical power from the surrounding media was accumulated along the length of the transmission antenna and with a closed oscillatory loop antenna 18 feet in length run parallel with the transmission antenna at a distance of approximately 20 feet, it was possible to obtain by tuning the loop antenna, sufficient power to light to full candle power a series bank of 50 sixty-watt carbon lamps. Lowering or raising the frequency of 500,000 Hz resulted in a diminishing of the amount of power received through the 18 foot antenna.

Likewise, raising the transmission antenna resulted in a proportionate decrease of power picked up on the receiving antennae and at 6 feet above the earth no power whatsoever was obtainable without a change of voltage and frequency.

It is the objective of my generic invention to utilise the power generated by the earth, by the means

described here and illustrated in the drawings. The two drawings show simple and preferred forms of this invention, but I wish it to be understood that no limitation is necessarily made as to the exact and precise circuits, shapes, positions and structural details shown here, and that changes, alterations and modifications may be made when desired within the scope of my invention and as specifically pointed out in the claims.

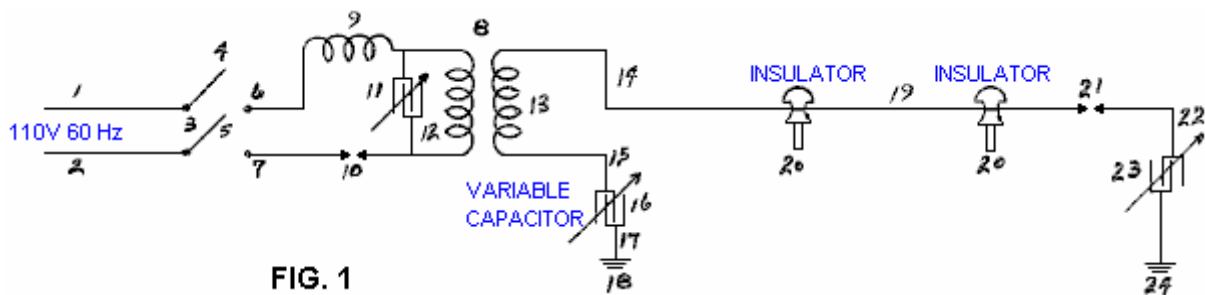

FIG. 1

Referring particularly to **Fig.1**, 1 and 2 are alternating current feed wires supplying 110 volts 60 cycles per second to a high-frequency generator. 3 is a switch with poles 4 and 5, while 6 and 7 are the connections to the high-frequency transformer 8, which is used to step-up the frequency to 500 kHz and the voltage to, say, 100 kV. 9 is an inductor, 10 is a spark gap, 11 is a variable capacitor, 12 is the primary winding and 13 the secondary winding of transformer 8. The secondary winding is connected to ground through variable capacitor 16, and wire 17. Wire 14 connects transformer 8 to the main transmission antenna 19 which is supported along its length on insulators 20. Spark gap 21 is positioned between the main transmission antenna 19 and the ground 24, passing through connecting wire 22 and variable capacitor 23. The main transmission antenna 19, can be any desired length.

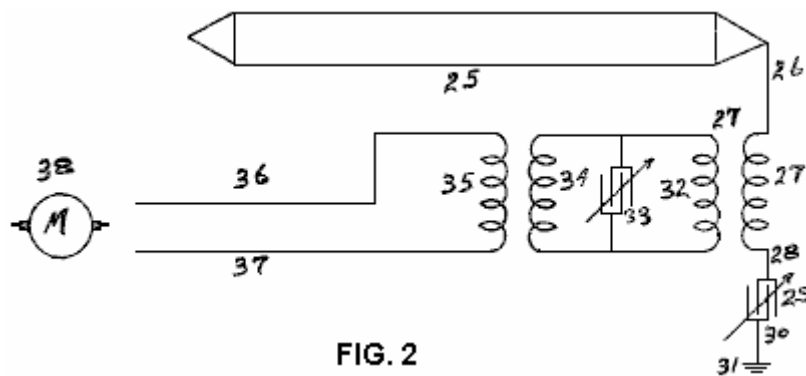
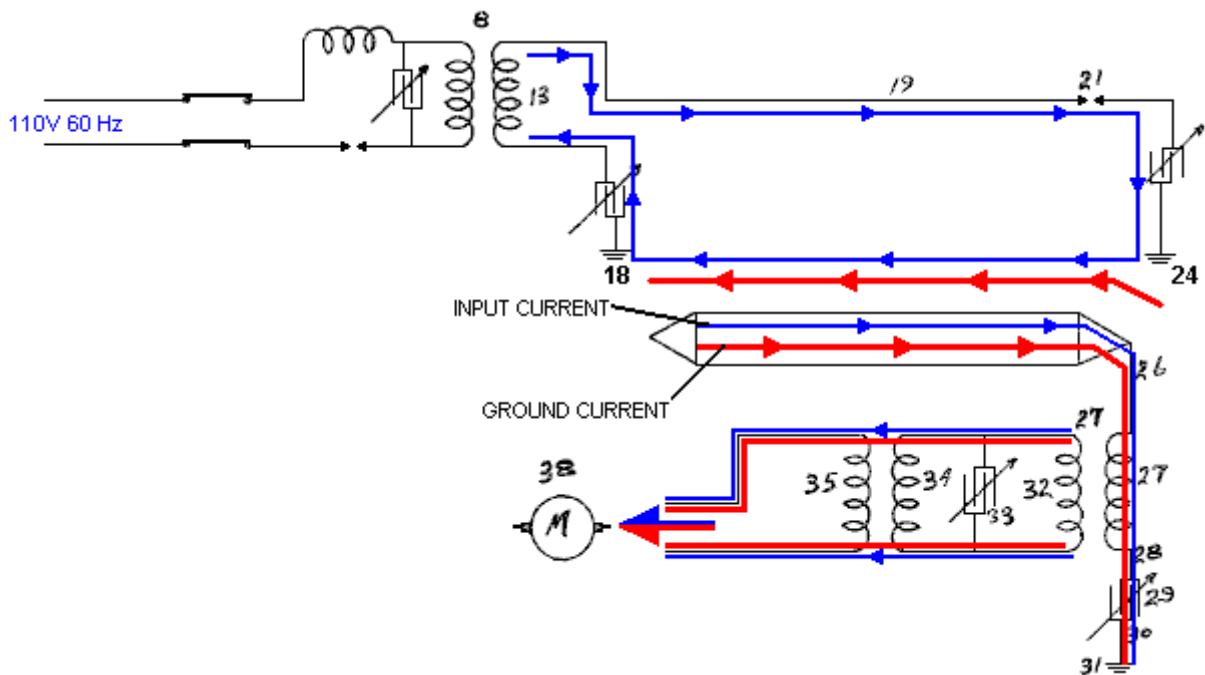

FIG. 2

In **Fig.2**, 25 is a closed oscillating loop antenna of any desired length. For greatest efficiency, it is run parallel with the main transmission antenna 19 of **Fig.1**. Wire 26 is connected to the secondary winding 27 of a step-down transformer which winding then goes to ground 31 through variable capacitor 29. The primary winding 32 of the step-down transformer has variable capacitor 33 connected across it and it feeds directly into winding(s) 34 of frequency transformer(s) which supply current through winding(s) 35 to a motor "M" or other electrical load(s).

Having described the drawings, I will now describe the operation of my invention. Operate switch 3 to connect the input power. Adjust spark gap 10 and variable capacitor 11 so that 100,000 volts at a frequency of 500,000 cycles per second is delivered to step-up transformer 8 of **Fig.1**. Next, adjust spark gap 21 of the transmission antenna 19 so that all (voltage) peaks and nodes are eliminated in the transmission of the 100,000 volts along the antenna by the current surges across spark gap 21. The high-frequency alternating current flowing through spark gap 21 passes through variable capacitor 23 to ground 24 and from there, back through the ground to earthing point 18, through variable capacitor 16 and back to winding 13 of transformer 8. As the 500,000 Hz current is the same as the earth-generated currents and in tune with it, it naturally follows that accumulation of earth currents will amalgamate with those for transformer 8, providing a reservoir of high-frequency currents to be drawn upon by a tuned circuit of that same 500 kHz frequency, such as that shown in **Fig.2**, where the antenna

25 is turned to receive a frequency of 500 kHz, which current then passes through transformer 27, any frequency-adjusting transformer(s), and on to power the load(s) 38.



The return of current through the earth from transmission antenna 19, is preferable to return through a wire as the ground return current picks up more earth currents than a wire does. I also prefer under certain conditions, to use a single antenna wire in place of the closed loop antenna shown in Fig.2. Under certain operational requirements, I have had improved performance by having the transmission antenna elevated and carried on poles many feet above the earth, and with that arrangement it is necessary to use a different voltage and frequency in order to accumulate earth currents.

This system of Frank's effectively applies very sharply pulsed DC pulses to a long length of wire supported in a horizontal position not far above the ground. The pulses are sharp due to both the spark gap on the primary side of the transformer, along with the spark-gap on the secondary (high voltage) side of the transformer. An input power of 500 watts gives a 3 kW power output from what appears to be an incredibly simple piece of equipment.

Dave Lawton's Solid-State Circuit.

A solid-state semiconductor circuit which has proved successful in producing pulses like this is shown as part of Dave Lawton's replication of Stan Meyer's Water Fuel Cell. Here, an ordinary NE555 timer chip generates a square wave which feeds a carefully chosen Field-Effect Transistor the BUZ350 which drives a water-splitter cell via a combined pair of choke coils at point "A" in the diagram below.

Stan Meyer used a toroidal ferrite ring when he was winding these choke coils while Dave Lawton uses two straight ferrite bars, bridged top and bottom with thick iron strips. Chokes wound on straight ferrite rods have been found to work very well also. The effects are the same in all cases, with the waveform applied to the pipe electrodes being converted into very sharp, very short, high-voltage spikes. These spikes unbalance the local quantum environment causing vast flows of energy, a tiny percentage of which happens to flow into the circuit as additional power. The cell runs cold, and at low input current, quite unlike an ordinary electrolysis cell where the temperature rises noticeably and the input current needed is much higher.

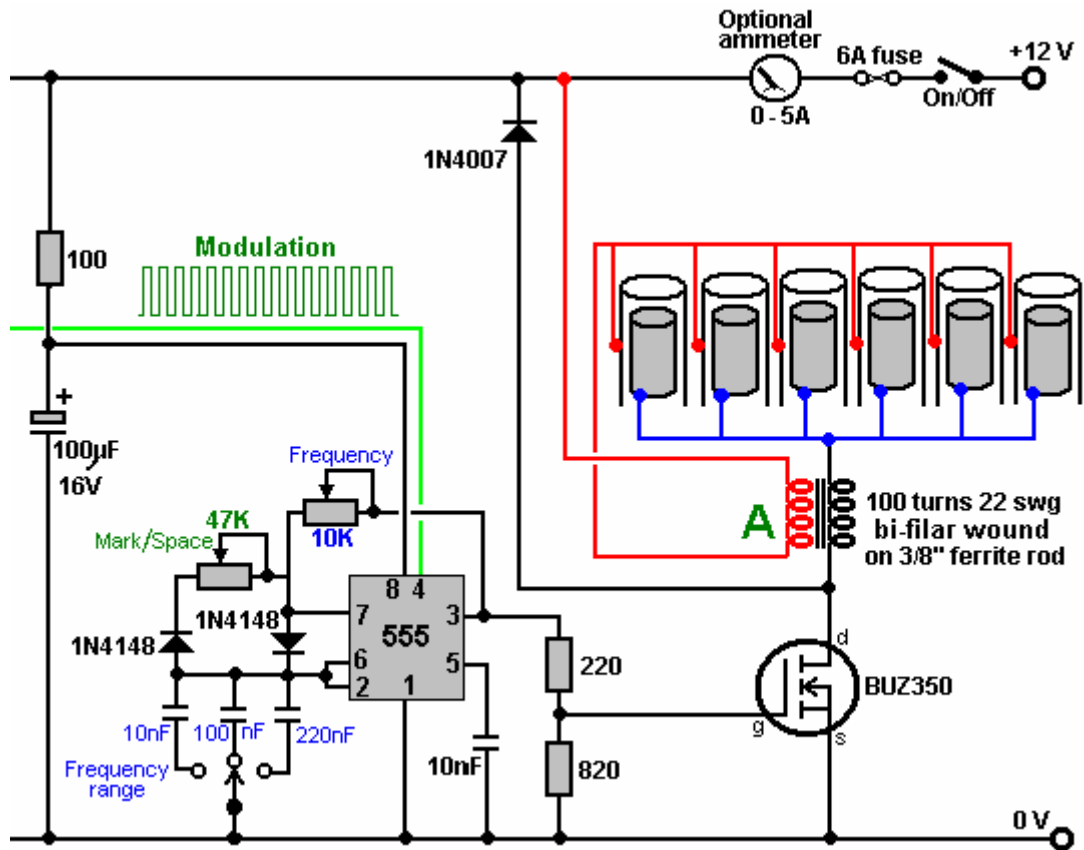

John Bedini's Battery-Charging Circuit.

John Bedini uses this same pulsing of a bi-filar wound coil to produce the same very short, very sharp voltage spikes which unbalance the local energy field, causing major flows of additional energy. The figure shown here is from his US patent 6,545,444.

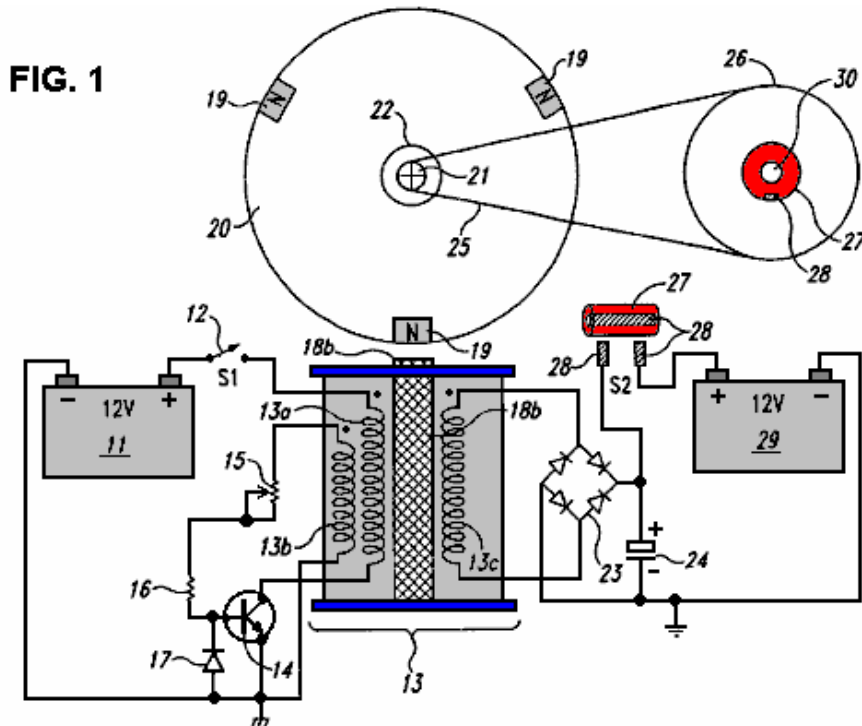

John has produced and generously shared, many designs, all of which are basically similar and all using a 1:1 ratio bi-filar wound transformer. This one uses a free-running rotor with permanent magnets embedded in its rim, to trigger sharp induced currents in the windings of the coil unit marked "13b" which switches the transistor on, powering winding "13a" which powers the rotor on its way. The pick-up coil "13c" collects additional energy from

the local environment, and in this particular circuit, feeds it into the capacitor. After a few turns of the rotor (dictated by the gear-down ratio to the second rotor), the charge in the capacitor is fed into a second “on-charge” battery.

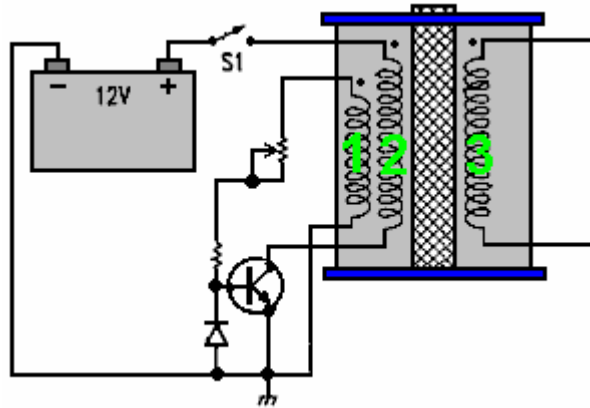

The rotor is desirable but not essential as the coils marked **1** and **2** can self-oscillate, and there can be any number of windings shown as **3** in the diagram. Winding **3** produces very short, sharp, high-voltage spikes, which is the essential part of the design. If those sharp pulses are fed to a lead-acid battery (instead of to a capacitor as shown above), then an unusual effect is created which triggers a link between the battery and the immediate environment, causing the environment to charge the battery. This is an amazing discovery and because the voltage pulses are high-voltage courtesy of the 1:1 choke coils, the battery bank being charged can have any number of batteries and can be stacked as a 24-volt bank even though the driving battery is only 12 volts. Even more interesting is the fact that charging can continue for more than half an hour after the pulsing circuit is switched off.

It can be tricky to get one of these circuits tuned properly to work at peak performance, but when they are, they can have performances of COP>10. The major snag is that the charging mechanism does not allow a load to be driven from the battery bank while it is being charged. This means that for any continuous use, there has to be two battery banks, one on charge and one being used. A further major problem is that battery banks are just not suitable for serious household use. A washing machine draws up to 2.2 kilowatts and a wash cycle might be an hour long (two hours long if a “whites” wash and a “coloureds” wash are done one after the other which is not uncommon). During the winter, heating needs to be run at the same time as the washing machine, which could well double the load.

It is recommended that batteries are not loaded much beyond their “C20” rate, that is, one twentieth of their Amp-Hour nominal rating. Say that 85 Amp-Hour deep-cycle leisure batteries are being used, then the recommended draw rate from them is 85 Amps divided by 20, which is 4.25 amps. Let’s push it and say we will risk drawing double that, and make it 8.5 amps. So, how many batteries would we need to supply our washing machine assuming that our inverter was 100% efficient? Well, 2,200 watts on a 12-volts system is $2,200 / 12 = 183$ amps, so with each battery contributing 8.5 amps, we would need $183 / 8.5 = 22$ large, heavy batteries. We would need twice that number if we were to treat them right, plus twice that again for household heating, say 110 batteries for an anyway realistic system. That sheer size of battery banks is not realistic for your average householder or person living in an apartment. Consequently, it appears that the Bedini pulse-charging systems are not practical for anything other than minor items of equipment.

However, the really important point here is the way that when these short pulses are applied to a lead-acid battery, a link is formed with the environment which causes large amounts of energy to flow into the circuit from outside. This is extra “free-energy”. Interestingly, it is highly likely that if the pulses generated by Dave Lawton’s water-splitter circuit shown above, were fed to a lead-acid battery, then the same battery-charging mechanism is likely to occur. Also, if a Bedini pulse-charging circuit were connected to a water-splitting cell like the Lawton cell, then it is highly probable that it would also drive that cell satisfactorily. Two apparently different applications, two apparently different circuits, but both producing sharp high-voltage pulses which draw extra free-energy from the immediate environment.

The Tesla Switch.

It doesn’t stop there. Nikola Tesla introduced the world to Alternating Current (“AC”) but later on he moved from AC to very short, sharp pulses of Direct Current (“DC”). He found that by adjusting the frequency and duration of these high-voltage pulses, that he could produce a whole range of effects drawn from the environment - heating, cooling, lighting, etc. The important point to note is that the pulses were drawing energy directly from the local environment. Leaving aside the advanced equipment which Tesla was using during those experiments and moving to Tesla’s simple-looking 4-battery switch, we discover the same background operation of sharp voltage pulses drawing free-energy from the environment.

Consider the Electrodyne Corp. circuit (shown in "The Manual of Free-Energy Devices and Systems", 1986) tested by them for a period of three years:

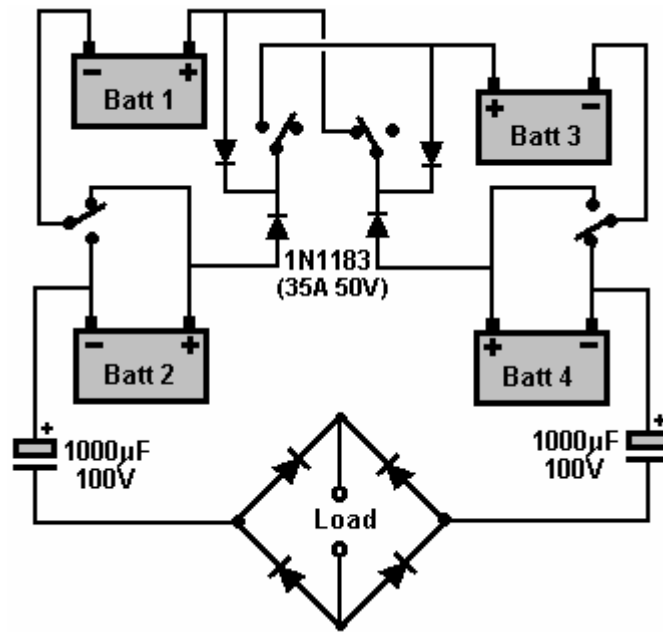

Please note that when I shared this circuit diagram several years ago, someone persuaded me that the diodes were shown the wrong way round, and because of that, I have shown these diodes incorrectly. The diagram above is the one shown by the Electrodyne Corp. staff, and is correct.

As the switching used by this device was a mechanical device which has six switches where three are ON and three are OFF at any moment, the Electrodyne Corp. staff present the circuit diagram like this:

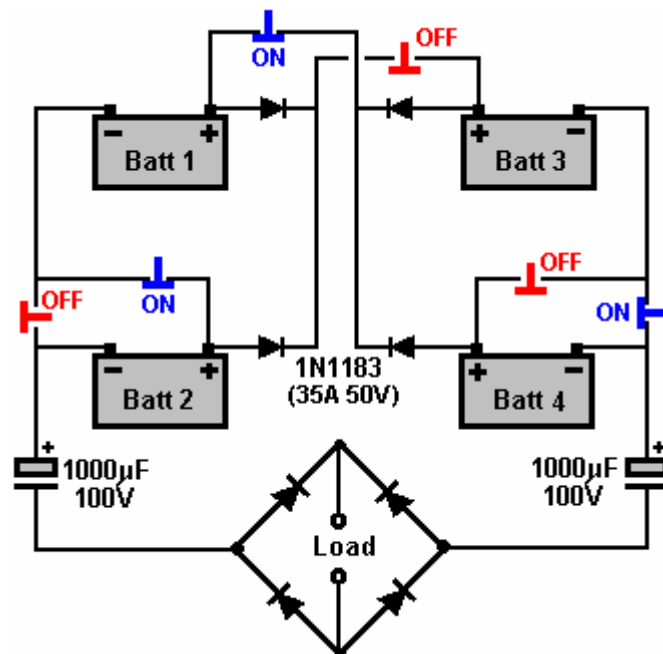

With switching like this:

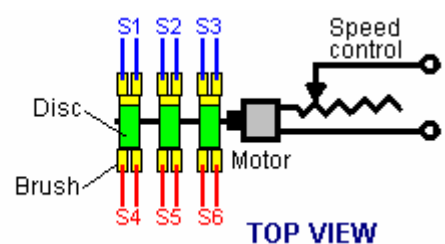
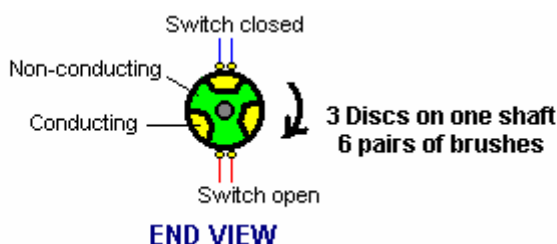
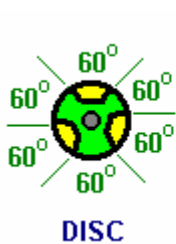

It is recommended that this simple-looking circuit has an inductive load, preferably a motor, but consider the results of that very extended period of testing. If the switching rate and switching quality were of a sufficiently high standard, then the load could be powered indefinitely. The batteries used were ordinary lead-acid batteries, and after the three years of tests, the batteries appeared to be in perfect condition. Their tests revealed a number of very interesting things. If the circuit was switched off and the batteries discharged to a low level, then when the circuit was switched on again, the batteries returned to full charge in under one minute. No heating occurred in the batteries in spite of the massive charging rate. If the circuit was switched off and heavy current drawn from the batteries, then heat would be produced which is quite normal for battery discharging. The system operated lights, heaters, television sets, small motors and a 30-horsepower electric motor. If left undisturbed, with the circuit running, then each battery would charge up to nearly 36 volts with no apparent ill effects. Control circuitry was developed to prevent this over-charging. This, of course, is easy to do as all that is required is to place a relay across one battery and have it disconnect the circuit when the battery voltage reaches whatever voltage is considered to be a satisfactory maximum voltage.

These test results show spectacular battery charging and battery performance, quite outside the normal range associated with these ordinary lead-acid batteries. Are they being fed very short, very sharp pulses, like the previous two systems? It would look as if they were not, but one other very interesting piece of information coming from Electrodyne is that the circuit did not operate correctly if the switching rate was less than 100 Hz (that is 100 switchings in one second). The Electrodyne switching was done mechanically via three discs mounted on the shaft of a small motor.

One other detail reported by the Electrodyne testers, is that if the switching speed exceeded 800 times per second, that it was "dangerous" but unfortunately, they didn't say why or how it was dangerous. It clearly was not a major problem with the batteries as they were reported to be in good shape after three years of testing, so definitely no exploding batteries there. It could well be as simple a thing that the voltage on each battery rose so high that it exceeded the voltage specifications of the circuit components, or the loads being powered, which is a distinct possibility. It is possible that at more than 800 pulses per second, the charging produced excessive cooling which was not good for the batteries.

It is generally accepted that for a circuit of this nature to work properly, the switching has to be very sudden and very effective. Most people have an immediate urge to use solid-state switching rather than the mechanical switching used by Electrodyne. A 'thyristor' or 'SCR' might be suitable for this, but the sharp switching of a PCP116 opto-isolator driving an IRF540 FET is impressive and a TC4420 FET-driver could substitute for the opto-isolator if preferred. It is possible that having a slight delay after the switches have turned On and Off, can prove very effective.

The Electrodyne Corp. staff used three identical discs mounted on the shaft of a motor as shown above. This allows the contact "brushes" to be located on opposite sides of the discs. There are, of course, many possible alternative constructions and I have been asked to show how I would choose to build this type of mechanical switching. The common idea of using mechanical relays is not very practical. Firstly, relays have trouble switching at the speeds suggested for this circuit. Secondly, with a contact life of say, two million and a switching speed of just 100 times per second, the relays would reach their projected lifespan after two weeks of operation, which is not a very practical option.

The objective is to have a simple construction which produces several switchings for each revolution of the motor, easy adjustment of the timing of two separate sets of three switches (one set being OFF when the other set is ON), a construction which can be taken apart and then assembled again without altering the timing, and an electrical connection method which is straightforward. Obviously, the construction needs to use components which are readily available locally, and ideally, only require simple hand tools for the construction.

This suggested construction allows adjustment of the timing for both the start of the first set of switches and the start of the second set of switches. It should also be possible to introduce a short gap between the operation of these two sets of switches. This particular design is assuming a gap between each switching operation as that may be beneficial.

The switch contacts are rigid arms, pulled against the rotating drum by springs. The contacts touching the drum can be of various types and the ones shown are brass or copper cheese-head screws or bolts which are particularly convenient as they allow standard solder tags to be used to make the connections to the switch wires which then run across to ordinary electrical screw connectors, all of which can be accessed from above. I would suggest that four screw connectors should be used as a block as that allows them to be fastened in position with two screws which then stops them rotating when the wires are being tightened. There should not be any need for the conducting inserts in the switching cylinder to be particularly wide in the direction of rotation.

A practical construction method might be:

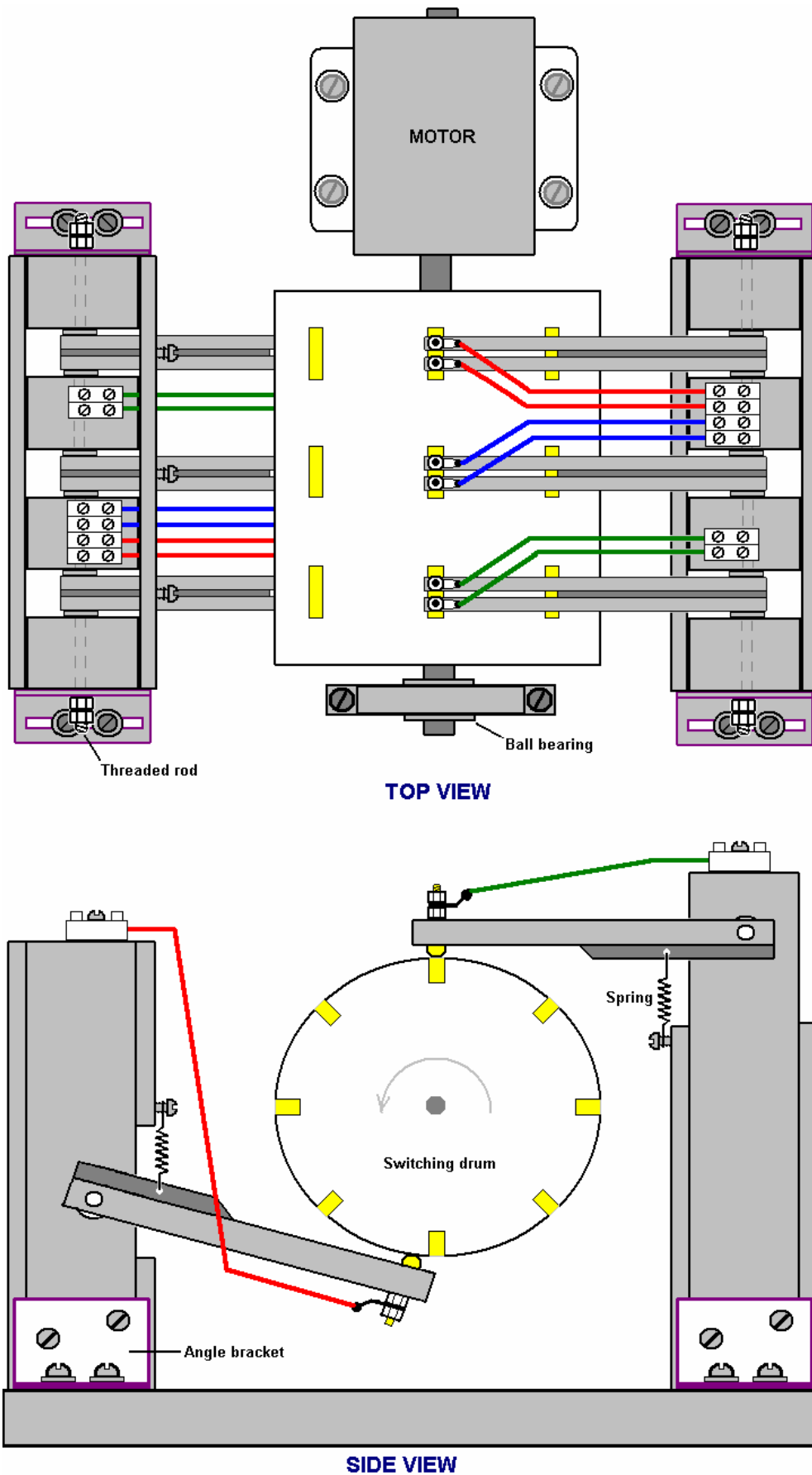

The contact arms are shown as attached to each other in pairs. A lower level of construction accuracy can be allowed if they are all kept separate and a spring used for each arm rather than one spring for two arms as shown

in the drawing. I strongly recommend that the switching drum be solid and the brass or copper insets be a fair thickness and keyed securely into the drum. The surface of the inserts should be very gently eased into exact alignment with the surface of the drum, possibly by the very careful use of a small file or lathe if you are lucky enough to have access to one.

The pivots for all of the switching arms can be a length of threaded rod with lock nuts at each end. There should be almost no movement of the switching arms when the drum is spinning, so no enormous precision is needed for the holes in the switching arms, through which the threaded rod runs. Having said that, it must be understood that each switch in the set of three, must turn On and OFF at the same time, so the contacts on the spring-loaded arms must slide on to and off the conducting strips in the switching cylinder, at exactly the same time.

The drawing shows three conducting inserts at each of eight evenly-spaced positions around the circumference of the drum. The number around the drum is not critical although this suggestion gives eight switchings per revolution. If you choose to use a different number, you need to remember that the positioning of the arms underneath the drum will be different. You need to arrange it so that just after one set runs off its conducting strips that the other set slides on to its conducting strips. Both sets of switches must not be ON at the same time as that short-circuits the batteries, which is probably not a good idea.

The timing adjustment is achieved by moving the supporting block slightly, by easing the four clamping screws, sliding the block and tightening the screws again. This, of course, is done when the drum is not rotating.

Each set of six switching arms needs to have all of the arms exactly the same length between the sliding contact (shown as a bolt head) and the pivot hole. Each of the conducting strips inset into the drum, need to be aligned exactly and be exactly the same width, otherwise the switching action will be ragged and not properly synchronised.

The supports for the switching arms can be either a single block with slots cut in it or the easier construction shown, where it is fabricated from several standard rectangular pieces and glued and/or screwed together.

The unequal amount of conducting strip compared to the non-conducting part means that there will be a timing gap between each pair of On/Off switchings. In spite of that, the battery switching will be a 50% Duty cycle as required. The switching sequence will then be: On / Off / Pause, On / Off / Pause, On / Off / Pause and that may well be a desirable arrangement as having an inter-pulse delay can be very good for battery charging.

However, please don't imagine that the Tesla Switch described here is a 'plug-and-play' device which you can switch on and it will give you the sort of outputs mentioned above, as that is very much not the case. You need to see the Tesla Switch as being a long-term development project with high potential.

If you use the Tesla Switch circuit with manual switches and run each phase for many minutes before altering the switching, it can give up to four times better performance than running the load off the four batteries in parallel. That is not what the Tesla Switch is all about.

The Tesla Switch is one of the more difficult devices to get operational, in spite of the fact that it appeals to a large number of people. There are three possible modes of operation. If the diodes are turned the wrong way round so that they can feed current from each battery, then the operation will definitely be COP<1 but it will be a good deal better than operating without the switch circuit in place.

The second way has only been achieved by John Bedini as far as I am aware. This is where the circuitry is the same but the circuit components and connecting wires are adjusted very carefully to produce circuit resonance. When that happens, the circuit becomes self-powering although there is little or no extra power for other devices.

The third way was developed and tested over three years by staff of the Electrodyne Corporation in America. In this version, the diodes are reversed and they only feed sharp voltage spikes back to the batteries, through the diodes which supposedly don't allow current to flow in that direction. This is a very different form of operation where the operating power flows into the circuit from the local environment. The batteries need to be 'conditioned' through long periods of being operated this way as the 'cold electricity' used in the circuit is the opposite of the 'hot electricity' which the batteries have been using up to now. This long conditioning period is generally enough to make the average builder give up and believe that the circuit just doesn't work. Dave Lawton was faced with exactly the same type of problem when he attempted to replicate Stan Meyer's "Water Fuel Cell". It appeared 'dead' and produced nothing during a whole month of testing, and then it suddenly burst into life, producing large amounts of HHO gas mix for almost no electrical input. Without his exceptional patience, Dave would never have succeeded. I believe that the same applies to the Tesla Switch when wired correctly with the diodes blocking current flow from the batteries – it is likely to take long-term and patient testing before the system swings into life.

One experimenter who did not believe the diodes could possibly work that way round, tested the arrangement and discovered that in spite of the theory, in practice, the reverse-biased diodes actually pass very sharp voltage

spikes to the batteries, so the effect may well be like a slick version of the various battery pulsing circuits shown in chapter 6.

Mechanical switching appears to work very well indeed, but if we decide to try using electronic circuitry, then we need to get an exact 50% Mark/Space ratio using a switching circuit, and so the following style of circuit might be used with a multi-turn preset resistor in position "A":

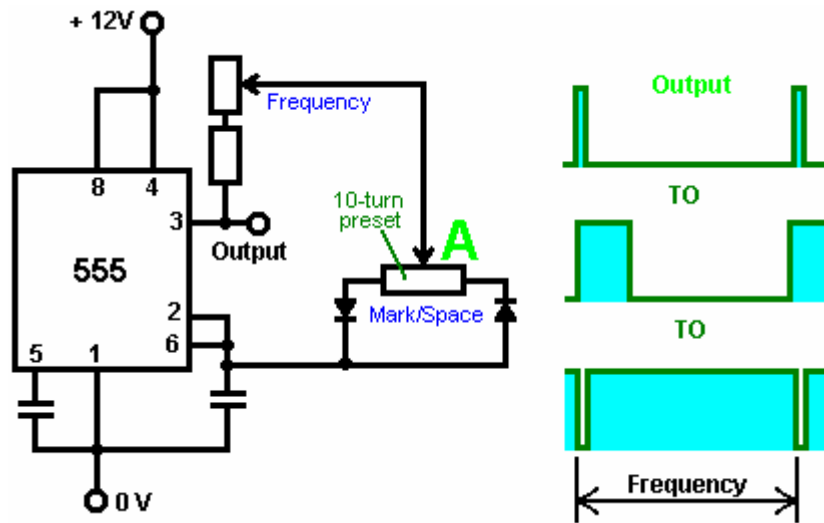

Here, the frequency is not noticeably affected by adjustment through a very wide range of Mark/Space settings. The output from Pin 3 needs to drive a very sharp switching combination such as a TC4420 FET driver connected to IRF540 FETs.

Perhaps the circuit might be something like this:

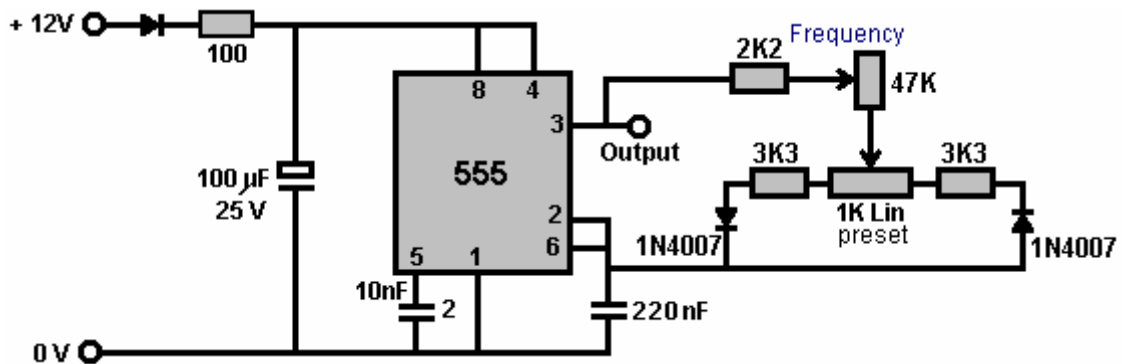

This circuit allows the Mark-Space ratio to be adjusted without altering the frequency, and the frequency can be adjusted without affecting the Mark-Space setting in any way. In the Tesla Switch circuit, three switches need to be in their On position and the other three switches in their Off position, so we will arrange this by using the ordinary NE555 timer circuit shown above, with its adjustable Mark-Space ratio (that is, variable On-to-Off ratio). We will use this circuit to drive six opto-isolators which will turn the six transistors On and Off in groups of three as required. To get the very high switching speed needed, PCP116 opto isolators should be used and although these are difficult to find, every effort should be made to get them as they enhance the switching speed.

Variable resistors come in a wide range of types. It is probably best to use a preset type as they are very easy to adjust and hold their settings very solidly. Also, when the correct setting is found, the component will be left on that position permanently. Some common types are:



where some can be adjusted from the top and others adjusted from the side. All of them can be mounted directly on the strip-board or printed circuit board used to construct the circuit.

However, the problem is to decide the direction of current flow and provide solid state components accordingly, as the Tesla Switch circuit almost certainly does not run with conventional electronic design. If you were to reverse the diodes shown in the first circuit diagram in this section, then the circuit will remain solidly COP<1 although some people have managed an operational improvement of 32 times over just using the batteries straight to power the load. With the diodes as shown in the first two diagrams in this section, the circuit operates by drawing in energy from the environment and that operates in an entirely different way in a circuit.

It is interesting to note that in the 1989 patent US 4,829,225 granted to Yury Podrazhansky and Phillip Popp, their evidence is that batteries charge much better and have a longer life if they are pulsed in a specific way. Their formula is that the battery should be given a powerful charging pulse lasting for a period of time between a quarter of a second and two seconds, the pulse being the Amp-Hour rating of the battery. That is, for an 85 Ahr battery, the charging pulse would be 85 amps. That pulse is then followed by a discharging pulse of the same, or even greater current but only maintained for only 0.2% to 5% of the duration of the charging pulse. Those two pulses are then followed by a resting period before the pulsing is repeated. They quote the following examples of their experiences when using this method:

Battery:	9V alkaline	1.25V NiCad 0.5 Ahr	15V NiCad 2 Ahr	12V lead-acid 40 Ahr
Charging current:	0.5 Amps	1.2 Amps	3.0 Amps	48 Amps
Charging period:	550 mS	700 mS	500 mS	850 mS
Discharge current:	6 Amps	6 Amps	14 Amps	85 Amps
Discharge period:	2 to 3 mS	2 mS	2 mS	3 mS
Rest period:	15 to 20 mS	7 to 10 mS	10 mS	15 mS
Charging range:	50% to 100%	20% to 100%	20% to 100%	20% to 100%
Total charging time:	12 to 15 mins	20 mins	35 to 40 mins	40 mins

Interestingly, this appears to confirm the charging potential of the Tesla Switch style of operation, especially if there is a short rest period between the two sets of switch operations.

A Three Battery Switching System

Continuing the Tesla Switch style of operation, it is possible to get the same effect as the Tesla Switch circuit, using only three batteries (or three capacitors). Discussed almost a century ago by Carlos Benitez in his patents, and more recently described by John Bedini, just three batteries can be used if more complicated circuit switching is used. Carlos points out that there has to be an energy loss due to wires heating up and batteries not being 100% efficient. He overcomes these problems with some very clever circuitry which is covered in the following section. However, it is not at all certain that this is actually the case as experimentation indicates that it is possible for this kind of battery switching to maintain the battery charge levels far beyond the expected.

Here is an untested suggestion for how it might be possible to produce a portable, self-powered powerful light. There are many possible variations on this, and the following description is just intended as an indication of how a three battery switching system might be constructed. If you are not familiar with simple electronics, then I suggest that you study the basic electronics tutorial of chapter 12.

Battery charging can be accomplished in various different ways. Obviously, the more the electrical loading can be reduced, the lesser the need for recharging. Two methods for doing this involve passing the same electrical current repeatedly through the load, as shown here:

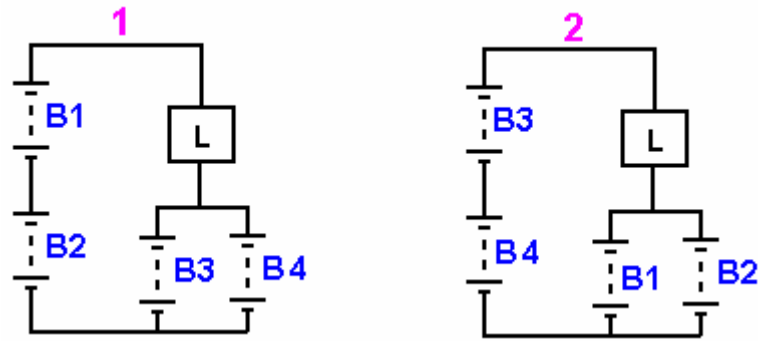

The switching for this arrangement can be implemented in various different ways, but essentially, in Stage 1, batteries 'B1' and 'B2' provide twice the voltage of batteries 'B3' and 'B4', causing current to flow through the load 'L' and into batteries 'B3' and 'B4', driven by the voltage difference which is normally, the same as the voltage of any one of the batteries on its own. Each of the batteries 'B3' and 'B4' receive only half of the current supplied by batteries 'B1' and 'B2', and so, there is, not surprisingly, an energy loss. However, for half of the time, batteries 'B3' and 'B4' are receiving charging current instead of supplying current to the load.

In Stage 2, the batteries are swapped around and the process repeated with batteries 'B3' and 'B4' supplying current to the load and batteries 'B1' and 'B2'. Tests have shown that with this arrangement, the load 'L' can be powered for longer than if all four batteries were connected in parallel and used to supply the load directly. With this system, each battery receives half of the load current for half of the time.

An alternative method which uses the same principle, but three batteries instead of four, and where each battery receives all of the load current for one third of the time, is like this:

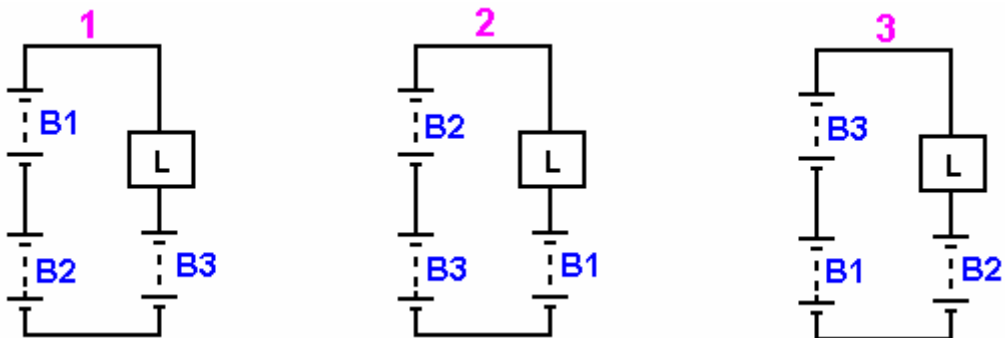

Here, the batteries are switched around sequentially, with two of them in series causing current flow through the load 'L' and into the third battery. There is, of course, an overall energy loss, and so, additional energy from an external source needs to be introduced to keep the load powered continuously. However, as with the four-battery system, the load 'L' can be kept powered longer by the batteries arranged like this than would occur if all three batteries were connected in parallel and used to power the load directly.

As before, the switching for a system of this kind can be implemented in various different ways. For long-term reliability, solid-state switching is preferred, and as NPN transistors are low-cost and readily available, they are shown here in one of the preferred configurations:

As each inter-battery connection is different for each of the three stages of operation of this circuit, it is necessary to have four switches for each stage. In order to establish the necessary details for connection of the transistors, as this circuit does not have the normal positive and negative rails, the (nominal) current flow directions need to be examined. These are shown here:

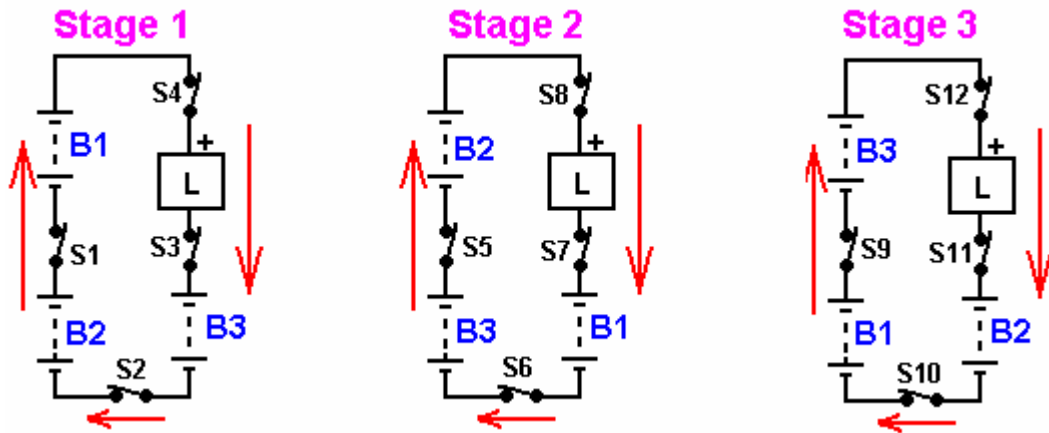

Obviously, the current flows from the higher series-connected voltage to the lower single battery voltage. The twelve virtual switches are numbered from 'S1' to 'S12' respectively, and if each represents an NPN transistor, then we also need to ensure that the current flow direction is correct for the transistor and to identify a higher voltage point which can be used to feed current into the base of each transistor. These details are listed here:

Stage	Switch	Type	Collector	Base resistor	Emitter
1	1	NPN	B2 Plus	B1 Plus	B1 Minus
	2	NPN	B3 Minus	B2 Plus	B2 Minus
	3	NPN	Load Minus	B1 Plus	B3 Plus
	4	PNP	Load Plus	B1 Minus	B1 Plus
2	5	NPN	B3 Plus	B2 Plus	B2 Minus
	6	NPN	B1 Minus	B3 Plus	B3 Minus
	7	NPN	Load Minus	B2 Plus	B1 Plus
	8	PNP	Load Plus	B2 Minus	B2 Plus
3	9	NPN	B1 Plus	B3 Plus	B3 Minus
	10	NPN	B2 Minus	B1 Plus	B1 Minus
	11	NPN	Load Minus	B3 Plus	B2 Plus
	12	PNP	Load Plus	B3 Minus	B3 Plus

The suggested switching arrangement therefore, looks like this:

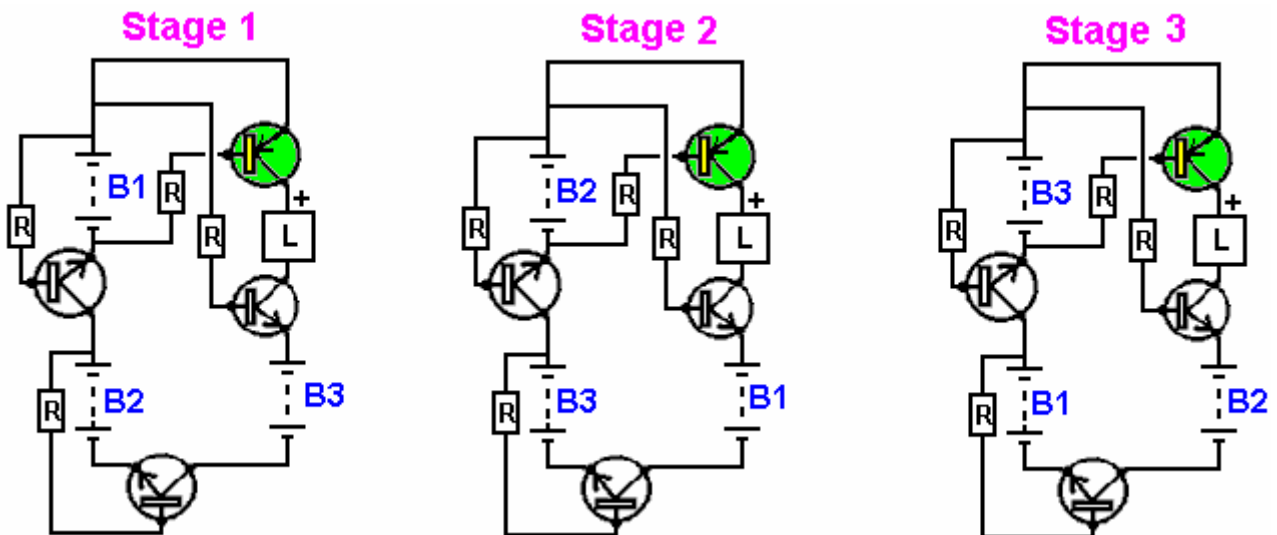

While the above diagram shows each stage with permanently connected base resistors, that is, of course, only to display the conceptual arrangement. Each resistor is passed through an opto-isolator and each set of four opto-isolators are driven by one of three separate outputs of equal duration. One possible arrangement for this could be as indicated below.

The CD4022 Divide-by-Eight chip can be arranged to divide by three rather than eight, by connecting its pin 7 to pin 15. The physical chip connections are:

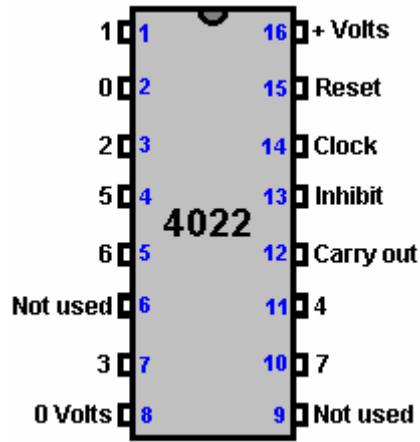

The chip needs a clock signal in order to function. There are many different ways of generating a clock signal, and the one shown here is very cheap, simple and has adjustable frequency and adjustable Mark/Space ratio, although, as the signal is to be used to trigger the action of a Divide-By-Three chip, there is no need for this clock signal to have a 50% Mark/Space ratio. The chip supply current is so tiny, that it really does not matter what the Mark/Space ratio is:

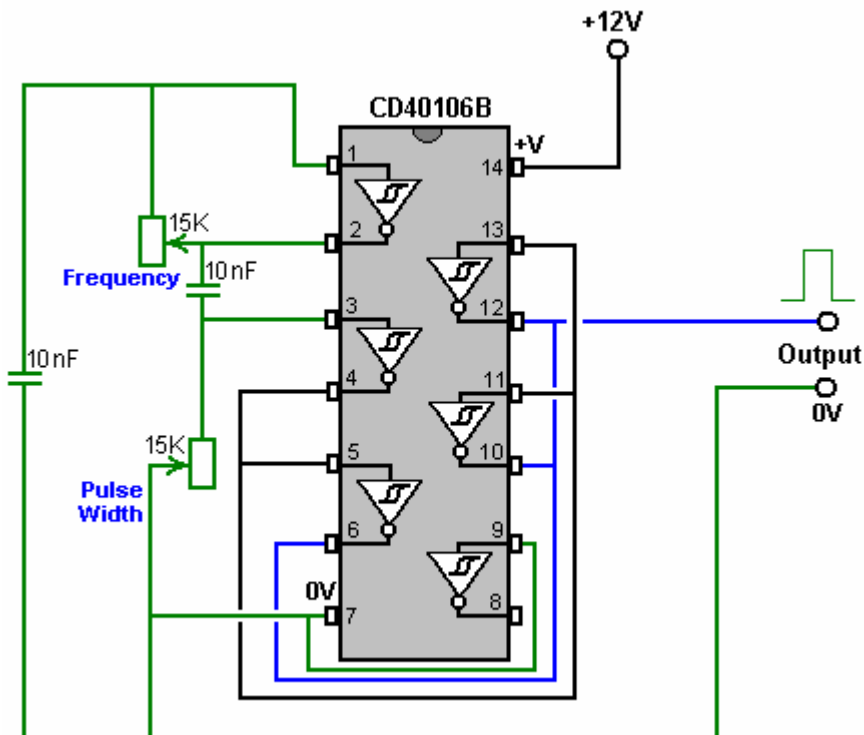

Using this circuit as the clock signal, the opto-isolator circuit could be:

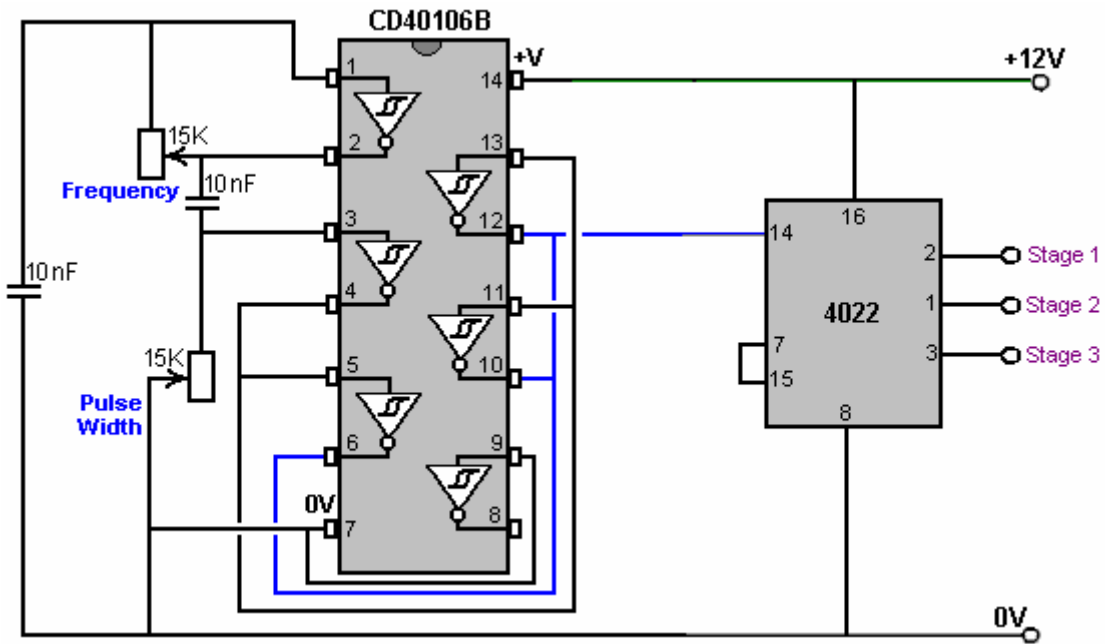

There are various opto-isolators available and while the rather expensive high-speed varieties are tempting, since we have to provide three sets of four, the ISQ-74 quad chip seems very suitable for this application although it is slower:

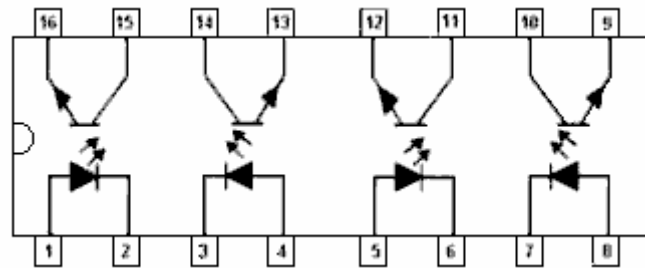

The overall circuit for the opto switching is then:

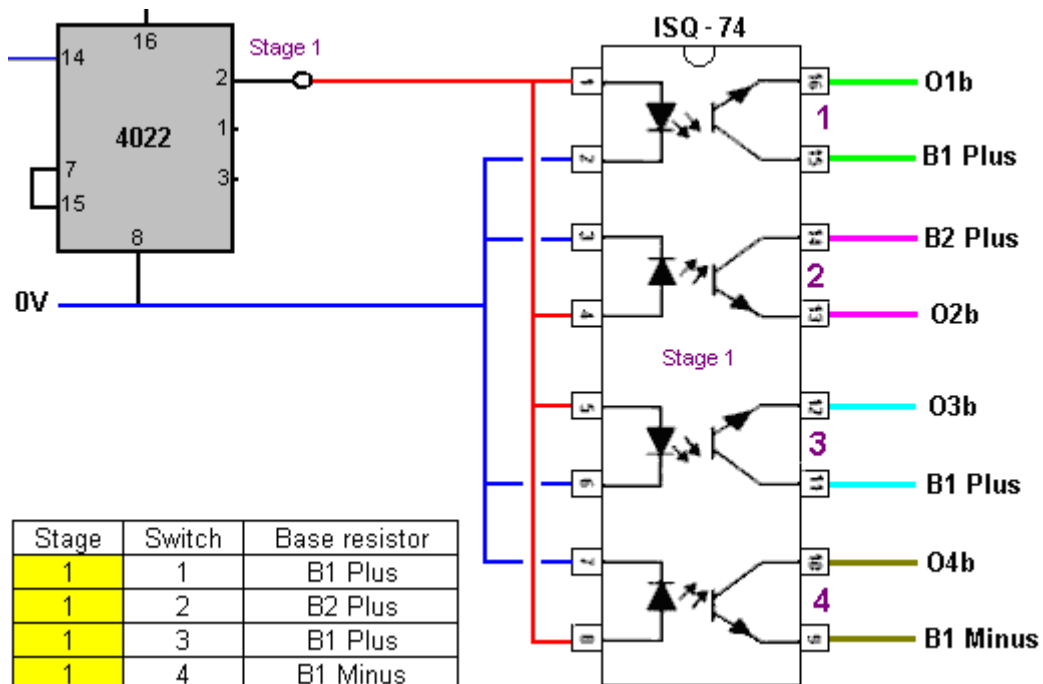

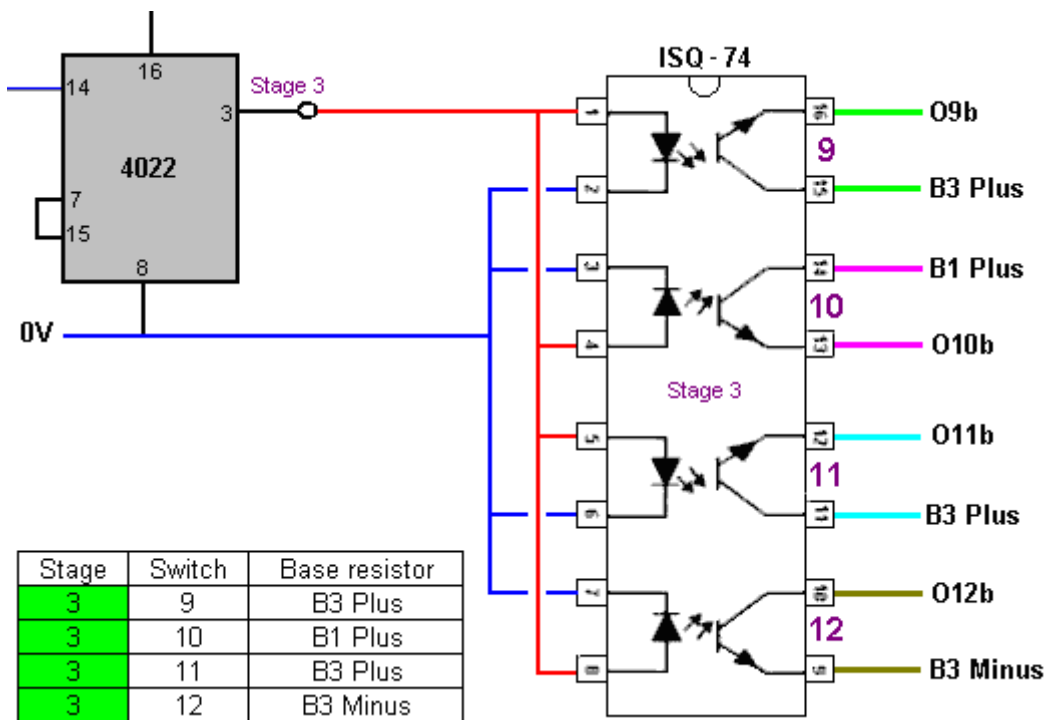
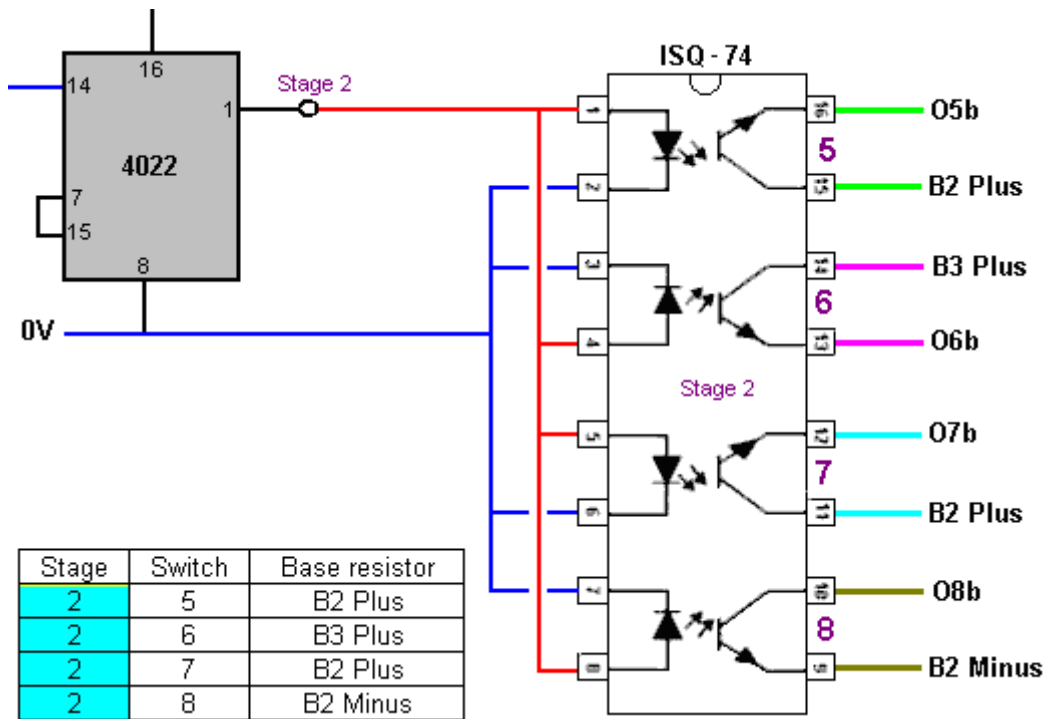

The output transistors are expected to switch 1 amp and so the TIP132 NPN and matching TIP137 transistors have been selected. These are cheap, Darlington transistors with current gains in excess of 1000 which means that the base current requirements are about 1 milliamp, which suggests that the base transistors could be 8.2K for a 12V system. These transistors can switch 12A at up to 100V and have a power dissipation of 70 watts, indicating that they will be running so far below their capability that they should run cool.

With this kind of circuit, it is desirable to have a fairly large current flow (relative to the battery capacity) in order to give a marked difference between the discharging and charging cycles for each battery. One possible load for this circuit could be the potentially low-cost G4 LED lighting unit shown here:



This quite remarkable device has a massive 160 lumens output with a lighting angle of 160 degrees and an input power of just 1.2 watts (100 milliamps at 12 volts). That light output is startling when seen in a completely dark place and some heat is generated, which is unusual for LEDs. A 100-watt filament light bulb has a light output of about 1600 lumens and a lighting angle of 360 degrees (some of which is normally not used usefully), and so, for the equivalent level of lighting, we would need ten of these G4 LED units, with a total power input of about 1 amp at 12 volts. Checking this in dark conditions, suggests that a much lesser lighting level would be more than acceptable. These LED lighting units are available in pure white and in “warm white” versions, and it is probable that the “warm white” version would suit most people better than the pure white versions.

Tests on one of the pure white units, shows a quite remarkable variation in the light output as the current is reduced, as the effect is highly non-linear:

At 12 volts the current is 1 amp. At 9.8 volts the current has dropped to a tiny 23 milliamps and while the light is nothing like as bright, there is still a considerable amount of light. At 9.42 volts, the light level is still significant and the current has dropped to a mere 10 milliamps. This suggests two main options: 10 LED units at 12 watts, providing a massive lighting level, or perhaps the same LED units run at 9.42 volts for just 1.2 watts of input power.

Using a 104 mm x 50 mm board size which will slot directly into a standard plastic slotted-side box, a stripboard layout (where the red circles indicate a break in the copper strip on the underside of the board) for the transistor switching section might be:

TIP137 (PNP)

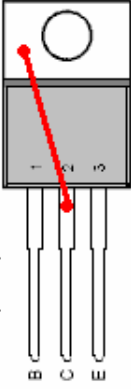

TIP132 (NPN)

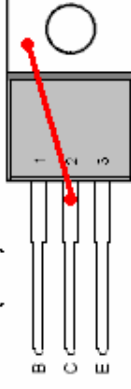

Stage	Switch	Type	Collector	Base resistor	Emitter
1	1	NPN 1	B2 Plus	B1 Plus	B1 Minus
1	2	NPN 2	B3 Minus	B2 Plus	B2 Minus
1	3	NPN 3	Load Minus	B1 Plus	B3 Plus
1	4	PNP1	Load Plus	B1 Minus	B1 Plus
2	5	NPN 4	B3 Plus	B2 Plus	B2 Minus
2	6	NPN 5	B1 Minus	B3 Plus	B3 Minus
2	7	NPN 6	Load Minus	B2 Plus	B1 Plus
2	8	PNP2	Load Plus	B2 Minus	B2 Plus
3	9	NPN 7	B1 Plus	B3 Plus	B3 Minus
3	10	NPN 8	B2 Minus	B1 Plus	B1 Minus
3	11	NPN 9	Load Minus	B3 Plus	B2 Plus
3	12	PNP3	Load Plus	B3 Minus	B3 Plus

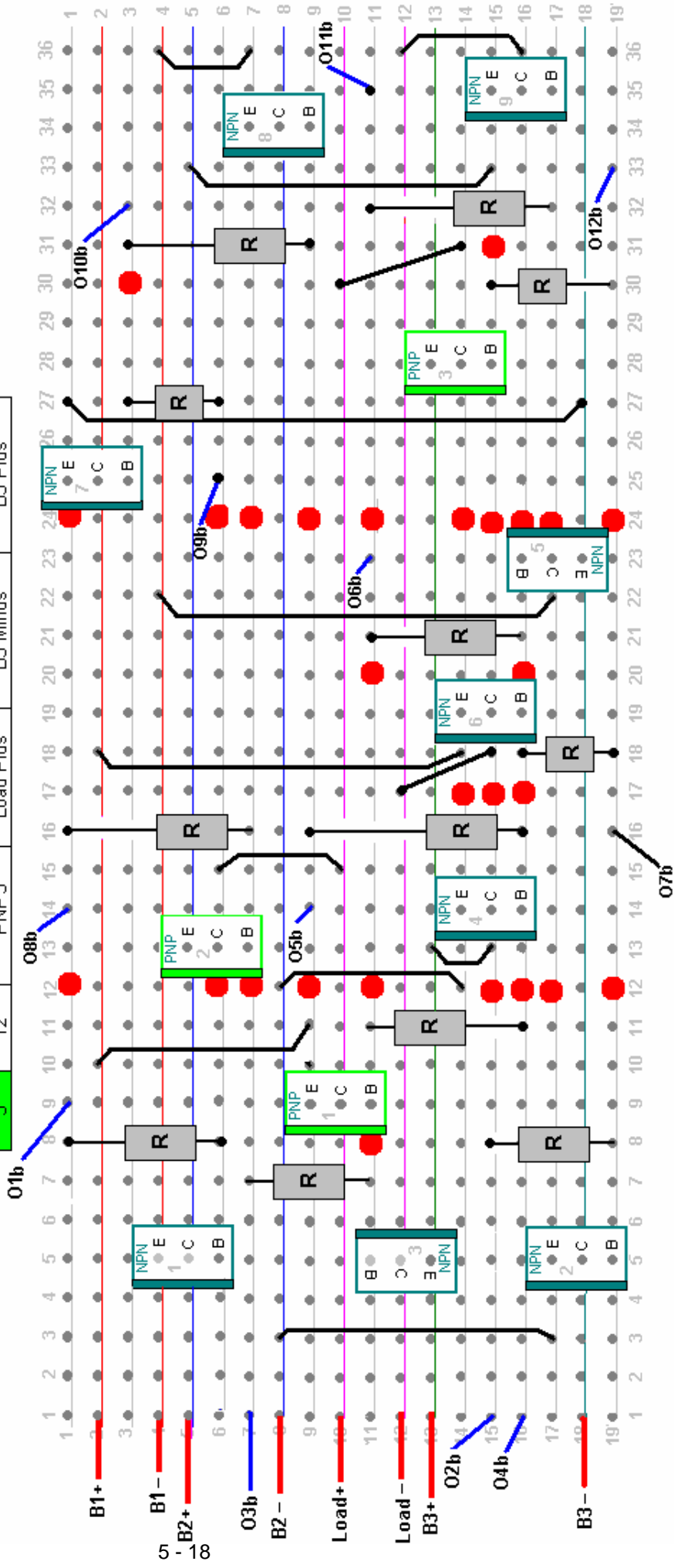

Each base resistor has an output link (O1b through O12b) which is connected through it's opto-isolator to the destination shown in the "Base" column in the table. Each set of three NPN transistors and one PNP transistor are switched together via a single ISQ-74 quad opto isolator chip. Each of the three ISQ-74 chips is powered in turn by one of the outputs from the CD4022 Divide-by-Three connected chip, which driven by the CD40106B hex Schmitt inverter chip wired as a clock as shown above. It is expected that a suitable clocking frequency would be about 700 Hz. A possible layout for the clock, Divide-by-Three and twelve opto-isolators on a 104 mm x 50 mm strip board, is shown here:

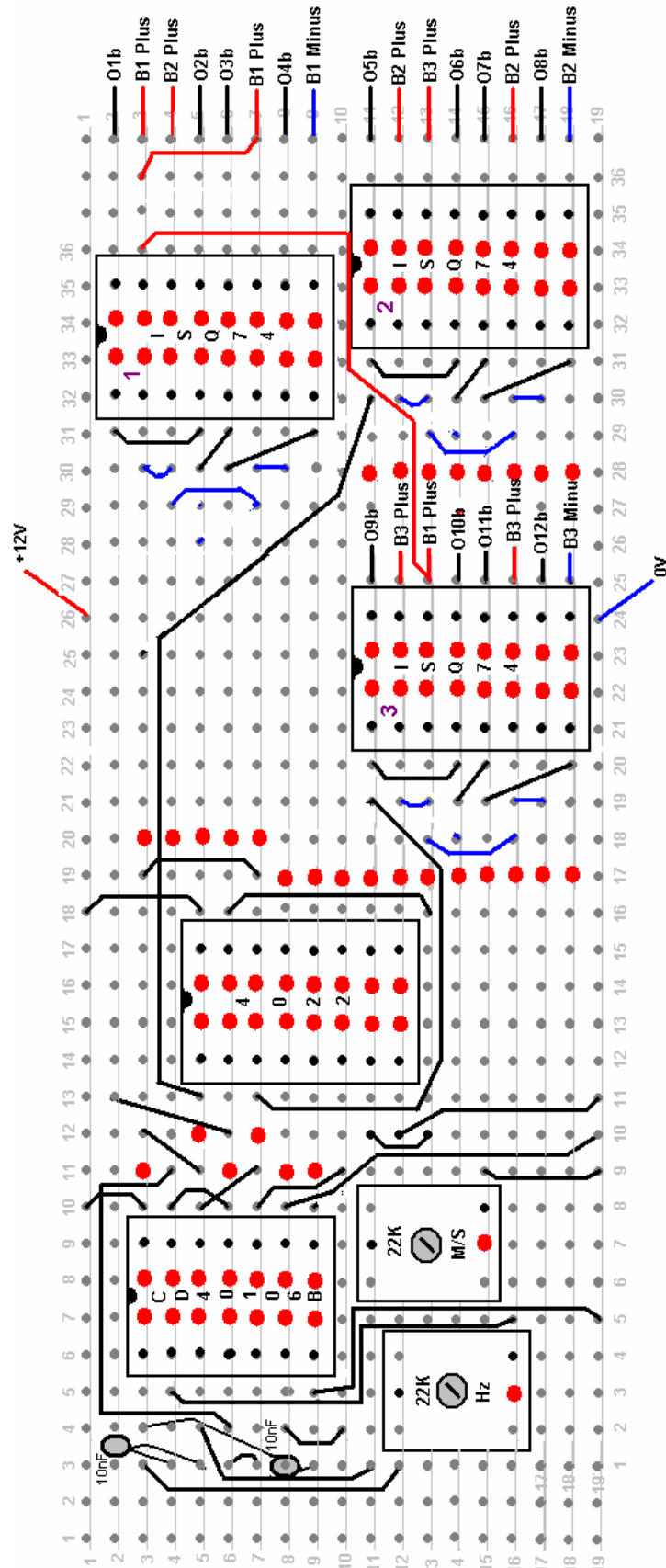

The timing and switching circuits form part of the load which is being switched. However, if we assume that there will be a power loss when running this system, then we should consider the very clever designs of Carlos Benitez in 1915.

The Self-powered Free-Energy Generators of Carlos Benitez

The Mexican Civil Engineer Carlos Benitez devised what is essentially the 3-battery switch discussed above. He was working at a time when solid-state electronics was not available and so his design is all the more impressive for that. Here is some of his patent information:

Carlos Benitez Patent GB 17,811 13th May 1915

System for the Generation of Electric Currents

I, Carlos F. Benitez, Civil Engineer, 141 Ocampo Street, Guadalajara, Mexico, do hereby declare the nature of this invention:

The invention relates to a new process for obtaining electric currents under unusually simple, economic and practical conditions. I use synthetically in combination: apparatus for the production of electric currents for charging one or several capacitors whose collectors or inner coatings are connected to one of the terminals of the primary winding of one or several induction coils and the other coatings of those capacitors are alternately grounded through the primary winding of a transformer, or connected through the transformer primary to the above collectors, appropriate means for collecting the currents produced in the secondary windings of these transformers and for applying charging to the above collectors, and an appropriate means for discharging those collectors, and for the application of all or part of its energy to the successive replication of the process already described, in this way, increasing the generation of electrical energy, or maintaining a constant, pre-determined electrical output.

Furthermore, the invention consists of a new combination of parts from which are derived advantages which will be fully understood by the consideration of the two different cases illustrated in the accompanying drawing, in which:

1 is a bank of capacitors.

2 is a rotating commutator to make and break the circuit connections at the appropriate instants.

3 is the primary winding of a transformer or induction coil.

4 is the secondary winding of that transformer or induction coil.

5 is a second bank of capacitors.

6 is an oscillator spark gap.

7 is the primary winding of a second transformer.

8 is the secondary winding of that transformer.

9 is a third bank of capacitors.

10 is the primary winding of a third transformer

11 is the secondary winding of that transformer.

12 is a fourth transformer.

13 is a series of incandescent lamps.

14 is an electric motor.

(a), (b), (c), (d), (e) and **(f)** are mercury-vapour converters or cathodic valves, allowing electric current flow only in the direction shown by the arrows.

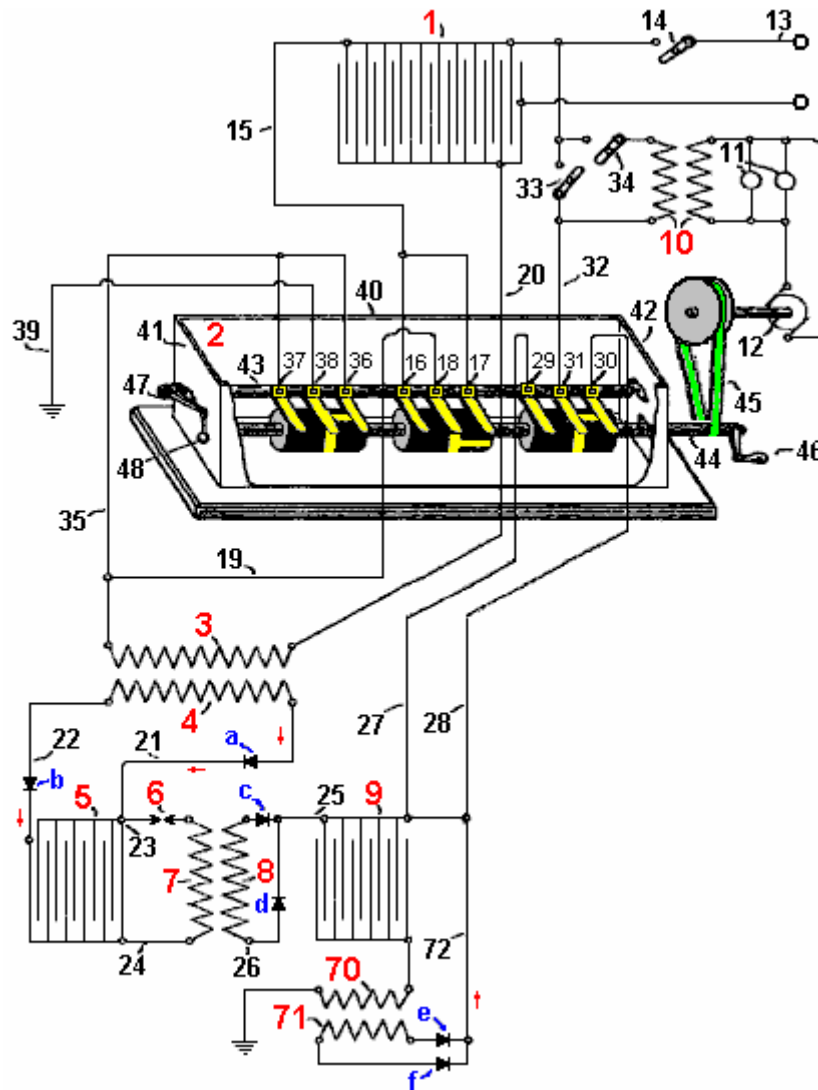

The capacitor bank 1, is connected through wire 13 to a source of electric current, providing the initial charge to capacitor bank 1. This initial charge is used to start the system running and can be disconnected at any time by means of switch 14.

Wire 15 connects the inner leaves of capacitor bank 1 with poles 16 and 17 of the commutator 2, and it's pole 18 is connected via wire 19 to one of the terminals of transformer primary winding 3, whose other end is connected through wire 20 to the outer leaves of capacitor bank 1. The secondary winding 4, of this transformer, is connected by wire 21 to the inner plates of capacitor bank 5, and by wire 22, to the outer plates of capacitor bank 5. In the same manner, wires 23 and 24 pass those connections on to the two sides of the primary winding 7 of the second transformer. Wire 23 also contains an oscillator spark gap 6, and wires 21, 22, 25, 26 and 72 contain the one-way cathode valves a, b, c, d, e and f. The secondary winding 8, of this second transformer, connects to the inner plates of capacitor bank 9, whose outer plates are connected to ground through the primary winding 70 of the third transformer. The secondary winding 71, of this third transformer is also connected through wire 72, to the inner plates of capacitor bank 9. Wires 27 and 28 also connect these inner plates to commutator poles 29 and 30, which form a change-over switch through commutator contact 31 which is connected to the inner plates of capacitor bank 1 through wire 32. Switches 33 and 34, allow the connection or disconnection of the primary winding of transformer 10, whose secondary winding supplies current to the incandescent lamps 11 and motor 12. Finally, one of the ends of primary winding 3 is connected through wire 35 to both pole 36 and pole 37 of the commutator 2, and their corresponding commutator contact 38 is connected to ground by wire 39.

As the construction and use of all of these components (with the exception of the commutator) is perfectly understood, it would be pointless to describe them. The commutator 2, is enclosed in a tank 40, whose end walls 41 and 42 support the ends of the contact-mounting bar 43, and the bearings of the rotating shaft 44. The contact bar is made of a non-conducting material to which are immovably attached, the copper contact strip brushes 16, 17 and 18, 36, 37 and 38, and 29, 30 and 31. Secure contact between these brushes and the rotating cylinders mounted on shaft 44 is ensured by the rotating lever arm 47 and its associated weight 48.

The three rotating cylinders mounted on shaft **44**, are made of a non-conducting material and have a conducting strip around their centre. This strip has two conducting spurs running outwards, one to the right and one to the left, positioned 180 degrees apart around the circumference of the cylinder. When shaft **44** is rotated, this causes the central contact (for example, **18**) to connect first to one of its associated contacts (say, **17**) and then disconnect and connect to the other contact (say, **16**) forming a change-over switching mechanism.

The switching strips on the central cylinder are positioned 90 degrees around the circumference when compared to the position of the switching strips on the two outer cylinders which are aligned with each other.

This can be seen in the diagram, where in the shaft position shown, **38** and **36** are connected and **31** and **30** are connected, while **18** is not connected to either **16** or **17**.

When shaft **44** is rotated through 90 degrees, **18** will be connected to **17**, while **31** and **38** will both be isolated.

When shaft **44** is rotated through an additional 90 degrees, brush **18** will be isolated while brush **38** will be connected to **37** and brush **31** will be connected to **29**.

When shaft **44** is rotated through an additional 90 degrees, brush **18** will be connected to brush **16**, while brushes **31** and **38** will be isolated.

[Note: if the diagram is correctly proportioned, there will be four positions in each rotation where the three central brushes are not connected to any of the outer brushes, producing the switching sequence Make, Break, Make, Break, Make, Break, Make, Break for each revolution. These breaks in the switching sequence have been shown to have a significant effect when batteries are being charged.]

Shaft **44** is elongated and projects through the end wall **42**, so that a belt drive **45**, or other suitable method, may be used to rotate the shaft, driven by motor **12** or possibly by crank handle **46**. The tank **40**, is filled with oil or any other insulating liquid, in order to prevent sparking between the brushes, which would lower the efficiency of the system.

This system is operated as follows:

With the commutator in the position shown in the drawing, that is, with brush **36** connected to **38** and brush **30** connected to **31**, and supposing capacitor bank **1** is connected through wire **13** to a source of electric power (say, a Wimshurst Machine), switch **14** being closed, electric current passes through wire **13** to charge capacitor bank **1**, causing a current to flow through wire **20**, primary winding **3**, wire **35**, brush **36**, brush **38** and wire **39** to earth. This current flow through primary winding **3** induces an inverse current in secondary winding **4**, which flows through wire **21**, charging capacitor bank **5** and then a direct induced current flowing through conductor **22**, charging capacitor bank **5**.

The current flow to both sets of plates in capacitor bank **5**, charges it and creates a spark across the spark gap **6**, causing a very sharp current pulse through primary winding **7**. This in turn, causes a considerable number of high-frequency oscillating current flows in the secondary winding **8** and these pass along wires **25** and **26**, and via diodes **c** and **d**, thus charging capacitor bank **9** and causing a corresponding set of high-frequency pulses to flow to ground through the primary winding **70**. This induces current flow in the secondary winding **71**, which flows through diodes **e** and **f**, and onwards via wire **72**, further boosting the charge on capacitor bank **9**.

Therefore, capacitor bank **1** being charged by an external source, capacitor bank **9** will be charged indirectly and successively re-charged several times, resulting in a quantity of electricity considerably greater than that of capacitor bank **1**. By this means, the system can be self-powered with no need for the power source used to start it, which means that switch **14** can be opened.

When shaft **44** rotates through 90 degrees, brush **17** connects with brush **18**, while brushes **31** and **38** are both disconnected. This causes capacitor bank **1** to be completely discharged through transformer primary **3**, causing the already described process by which capacitor bank **9** receives a substantially larger electrical charge. This results in capacitor bank **1** being totally discharged and capacitor bank **9** being highly charged with a great deal of electricity. Consequently, if we now close switch **33** and rotate shaft **44** through another 90 degrees, the following situation results:

1. Brushes **17** and **18** will be disconnected.
2. Brushes **37** and **38** become connected which in turn connects the outer plates of capacitor bank **1** to ground. Brushes **29** and **31** are connected, which then connects the inner plates of capacitor bank **9** to the inner plates of capacitor bank **1**.

3. Part of the high charge on capacitor bank 9 will flow as an electric current, through wire 32 and into capacitor bank 1.
4. This current flow from the inner plates of capacitor bank 9 causes an immediate matching negative charge to flow from ground through primary winding 70, to offset the charge imbalance.
5. This induces a current flow in the secondary winding 71, which passes additional electrical power to the outer plates of both capacitor bank 9 and capacitor bank 1, and that further intensifies the current flow through primary winding 70 quite considerably.
6. Further, as capacitor bank 1 has just been newly charged, it drives additional current through primary winding 3, causing new induced currents which will, as before, produce much increased charge on the inner plates of both capacitor bank 5 and capacitor bank 9, as described earlier.

If shaft 44 is rotated through a further 90 degrees, then a connection between brushes 16 and 18 will be made and all other circuits will be opened, causing capacitor bank 1 to be discharged again, thus repeating the entire process described above provided that shaft 44 is rotated continuously.

This system produces a constantly increasing supply of electric current flowing through wire 32, and so, switch 34 can be closed, allowing transformer 10 to provide the electrical power to run motor 12 which maintains shaft 44 in continuous rotation, making the system self-powered with no requirement for any form of outside power supply. Additional transformers inserted in wire 32 can be used to power additional equipment.

Without employing the high-frequency currents described above, similar results may be attained by means of the arrangement shown at the lower right hand side of the following drawing:

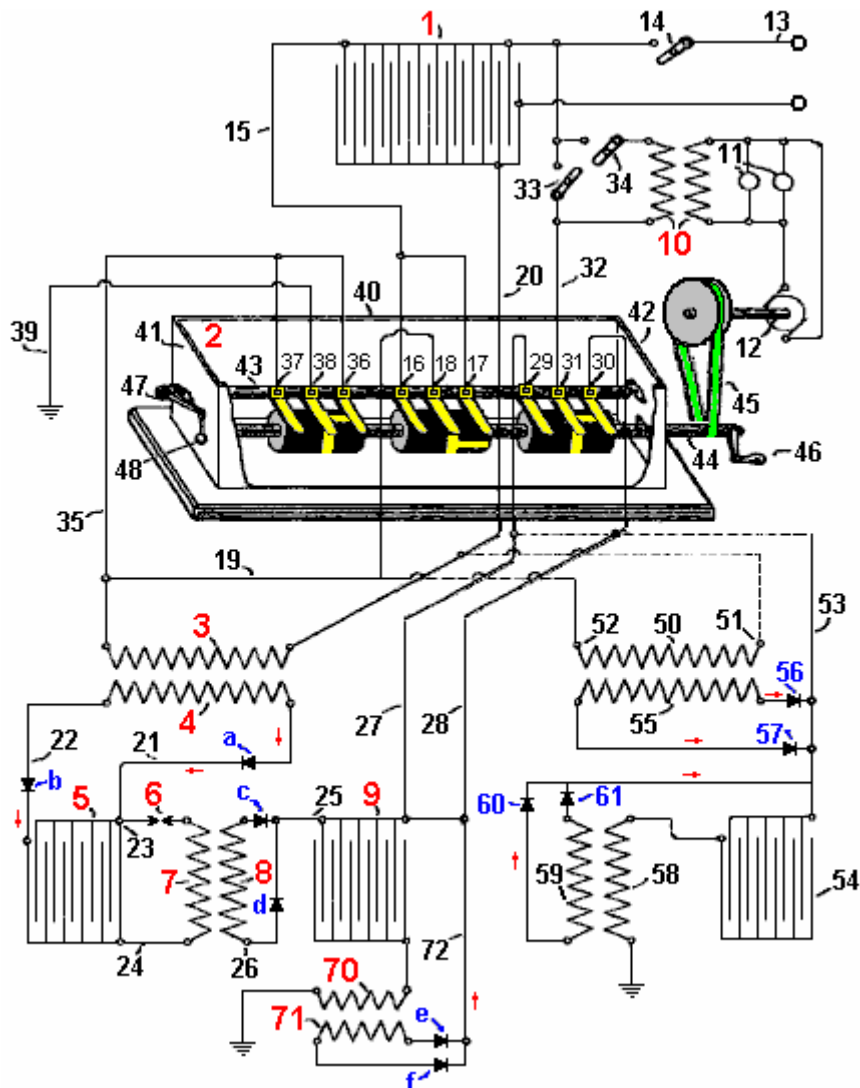

Here, primary winding 50 is connected as shown by the dashed lines, with wires 19 and 20 of the former arrangement, and wire 53 connects to both wire 27 and wire 28. This arrangement has primary winding 50 connected through its end 51 to wire 20 and so is permanently connected to the outer plates of capacitor bank 1, and its other end 52 being connected to wire 35 will be intermittently connected to ground. Wire 53 being

connected to wires **27** and **28** will intermittently connect together, the inner plates of capacitor bank **54** and the inner plates of capacitor bank **1**.

With this arrangement, both ends of the secondary winding **55** are connected through diodes **56** and **57**, to wire **53**. The outer plates of capacitor bank **54** are permanently connected through primary winding **58** to ground. Both ends of the secondary **59** are connected through diodes **60** and **61**, back to wire **53**. As a result, if capacitor bank **1** is charged, it drives a current through wire **20** and so, through primary winding **50**, and on to ground through wires **35** and **39**. This induces current in secondary winding **55** which gets stored in the inner plates of both capacitor bank **54** and capacitor bank **1**, as in this moment, the circuit is closed between brushes **29** and **31**, and so, wire **53** is connected to wire **32**. On receiving these new charges, both capacitor bank **1** and capacitor bank **54** will create new induced electric currents flowing through primary windings **50** and **58**. These multiple charging pulses will decrease with time until they are insignificant, at which time, due to the rotation of shaft **44**, the connection between brushes **29** and **31** and between brushes **36** and **38** will no longer be maintained, and instead, brushes **18** and **17** will become connected, discharging capacitor bank **1** through primary coil end **50** which is a very strong discharge, charging capacitor bank **54** as wire **53** is now disconnected from wire **32**. This, in turn, causes powerful current flow through primary winding **58**, further charging capacitor bank **54** which then feeds capacitor bank **1** when shaft **44** rotates further, making the system both self-powered and capable of supplying useful electrical power to other equipment.

It should be clearly understood that the use of mercury-vapour converters or cathodic valve diodes as described, are not in any manner indispensable in the system as those devices can be replaced by a suitable arrangement of capacitors which would receive separately, the direct and inverse currents of the secondaries.

When a bell is struck just once, it vibrates many times, passing those vibrations to the air and so, making the sound which we hear. The bigger the bell, the slower the vibrations and the lower the pitch of the note which we hear. The same thing happens when a sharp voltage pulse is applied to a coil of wire as just one pulse causes many vibrations in the coil. Like the bell, the frequency of the vibrations depends on the structure of the coil and not on how it is pulsed, although, like a bell, a sharp pulse for a coil or a sharp blow for a bell, produces a greater effect.

You will notice here that Carlos uses the resonant 'ringing' of an air-core coil to get an energy gain which is then used as positive feedback to further charge a capacitor bank. A single sharp pulse generated by one spark, causes a large number of coil oscillations, each of which contributes output power, producing an energy gain. The ringing frequency is liable to be around 3 MHz. It is also worth noting that with this design, electricity generation can be achieved without any battery and just the manual turning of a Wimshurst electrostatic generator and the initial operation of the commutator shaft **44**.

Carlos also produced another design, this time working with batteries (although he tended to think in terms of 60-volt battery banks rather than 12-volt batteries) and his patent includes what we tend to call the Tesla Switch nowadays. Perhaps we should call it the Benitez Switch. However, instead of switching it rapidly, Carlos uses a switching time interval of one hour. The lower voltage overcomes the need for the switching contacts to be submerged in oil.

Carlos Benitez Patent GB 14,311 17th August 1916

System for the Generation of Electric Currents

I, Carlos F. Benitez, Civil Engineer, 141 Ocampo Street, Guadalajara, Mexico, do hereby declare the nature of this invention:

The invention which forms the object of this Patent of Addition, relates to new improvements in the system for the generation of electric currents, described in the main patent No. 17,811 and in the patent of addition No. 5591, filed 14th April 1915.

The system may be still further simplified and improved by the addition of batteries, which, suitably adjusted in conjunction with system previously described, can be charged and discharged alternately, producing an excess of electrical energy which can be used in any desired manner.

In other words, in this arrangement, I use in combination: two batteries connected in series and two batteries connected in parallel, these pairs being used so that the discharge of one pair is used to charge the other pair, and *vice versa*.

Another object of this new arrangement is to allow the use of low voltages, small capacity capacitors and additional facilities for starting the system.

The advantages of such an improvement will be better understood by considering the following drawing which illustrates one method of carrying out the invention:

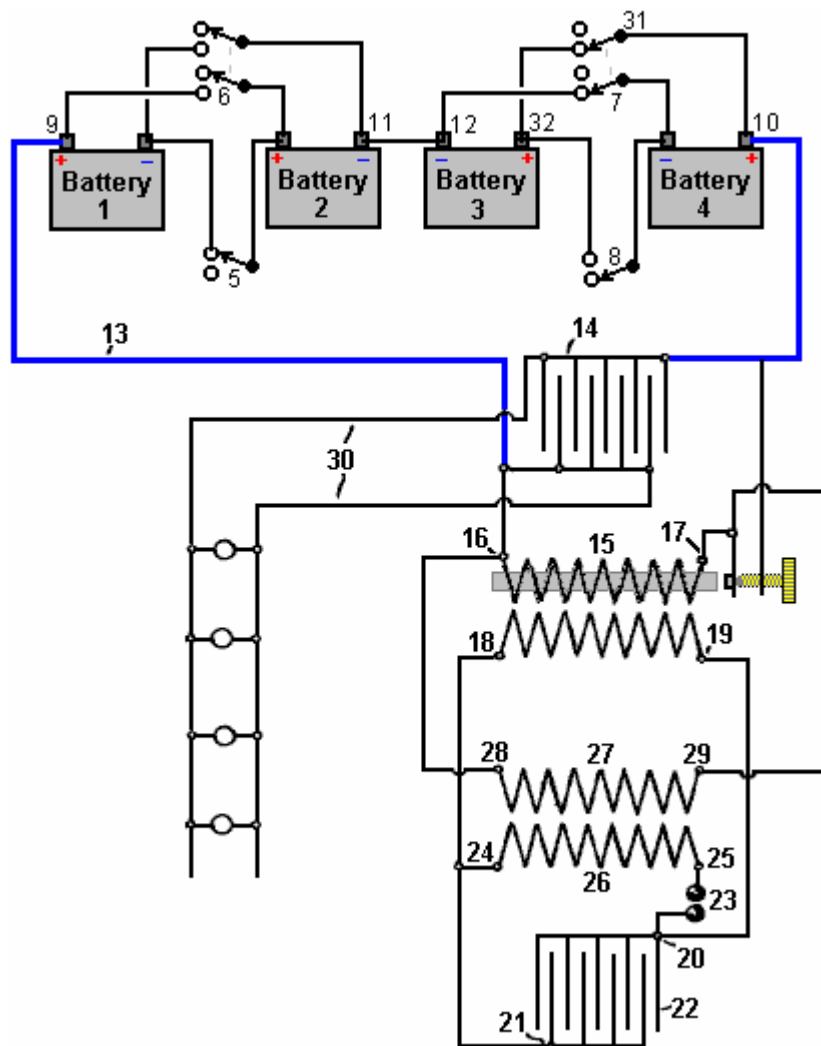

In the diagram, 1, 2, 3 and 4 are batteries which, when charged from some external source, will maintain their charges indefinitely, in the following manner:

With the connections established as shown in the diagram, that is, with batteries 1 & 2 connected in series through switch 5 (switch 6 being open), batteries 3 & 4 are connected in parallel through switch 7 (switch 8 being open). Under these conditions, assuming that the four batteries are similar, having similar voltages, batteries 1 and 2 being in series will have a combined voltage greater than batteries 3 and 4 which are connected in parallel, and so, a load connected between them will have a current flowing from batteries 1 & 2 and into batteries 3 & 4.

In other words, if wire 13 is connected to the positive terminal of the battery 1 & 2 combination, and to the positive poles 10 & 32 of the battery 3 & 4 combination, then an electric current will be established between the two sets of batteries, until their voltages match. Of course, the current provided by batteries 1 & 2 would produce a smaller charge in the batteries 3 & 4, but that current can be increased by any of the methods described in my earlier patents (No. 17,811/14), and by these means it is always possible to alternately charge and discharge the battery pairs from each other, keeping a constant, pre-determined charge, and furthermore, producing an excess of electrical energy which can be used for any chosen purpose.

With these objectives in view, and using as an illustration, the arrangement shown in Figure 1 of the Patent of Addition No. 5591/15, wire 13 connects to capacitor 14. The primary winding 15 of an ordinary induction coil provided with an interrupter, is connected by its ends 16 and 17, to wire 13. The ends 18 and 19 of the secondary winding of that induction coil 15 are connected to connections 20 and 21 of capacitor (or bank of capacitors) 22. Connections 20 and 21 are also connected through spark gap 23, to ends 24 and 25 of the primary winding 26 of a high-frequency transformer. The ends 28 and 29 of the secondary winding 27 of that transformer are connected

to ends **16** and **17** of the induction coil **15**. Finally, wires **30** are connected across capacitor **14** and they are used to power external loads such as the incandescent lamps shown in the diagram.

This arrangement being made, the electrical energy stored by batteries **1 & 2**, passing through terminal **9**, wire **13**, primary winding **15**, terminal **10** of battery **4**, pole **31** of switch **7** and terminal **32** of battery **3**, will go back through terminal **12** of battery **3** to the battery **1** and **2** combination.

As a consequence of the current passing through primary winding **15**, high-voltage current is produced in its secondary winding and collected in capacitor **22**, discharging through spark gap **23**, generates high-frequency currents in the high-frequency transformer primary and secondary coils **26** and **27**. As coil ends **28** and **29** are connected to coil ends **16** and **17**, this greatly augments the current flow provided by batteries **1 & 2** and so the storage batteries **3** and **4** now receive adequate charging current to keep them fully charged as well as driving additional loads via wires **30**.

Under these conditions, as the voltage in one of the batteries is decreasing while the other is increasing, after some hours, both voltages match and it is then impossible to produce any current flow unless switches **5, 6, 7** and **8** are operated, reversing the functions of the batteries and allowing the process to continue entirely as before with batteries **1 & 2** being connected in parallel and batteries **3 & 4** being connected in series.

When the resistance of the primary winding of transformer **15** is not high, it is possible to simplify the above circuit by obtaining the high-frequency currents directly from induction coil **15**, in which case, ends **18** and **19** of the secondary winding are connected directly to ends **16** and **17** of the same coil and the second bank of capacitors **22** and the high-frequency transformer **26/27** can be omitted. Under these conditions, the breaker or interrupter which is part of the induction coil construction, acts as a spark gap, and capacitor **14** discharges in the form of oscillations through the primary winding **15** of the same coil, thus directly increasing the amount of electrical energy furnished by the accumulators.

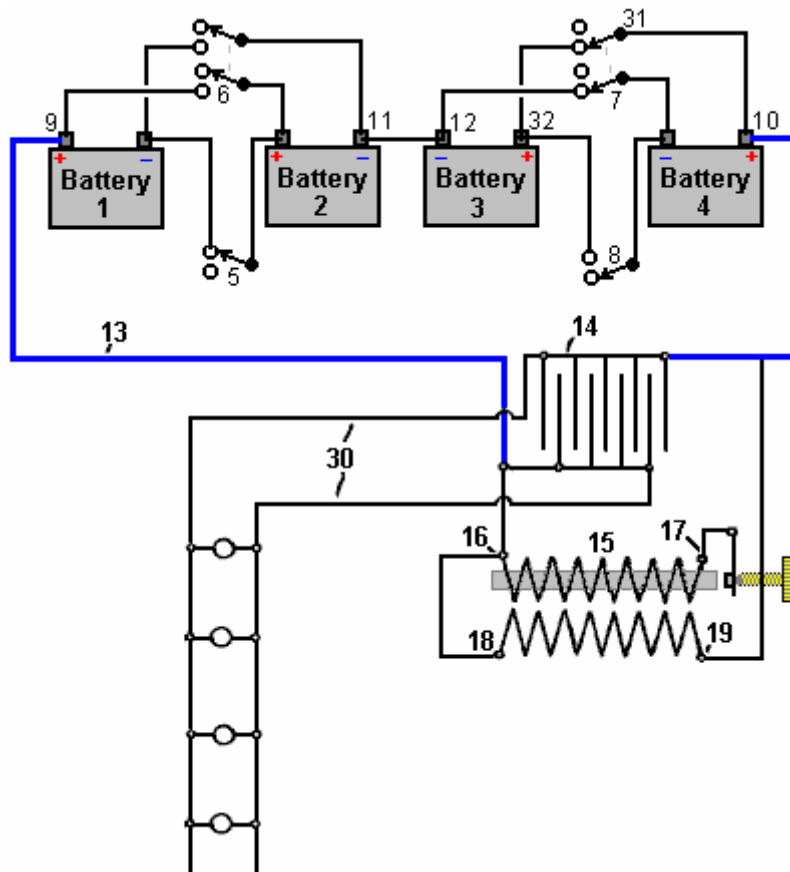

An essential part of this design which is not indicated clearly in the patent, is that what was common practice a hundred years ago, namely, that the input power connection to point **17** of the primary of the (step-up) transformer **15**, is fed through an “interrupter” contact. This connection opens when the coil **16-to-17** is energised, causing the insulated iron wire bundle core of the coil to become magnetised, and attract the pivoted arm of the interrupter, which breaks the current to the coil very sharply, causing high frequency resonant oscillations in both windings of the transformer **15**, which generates the excess power which runs the system and its additional loads. In Benitez’s day, door bells used this style of interrupter to produce a hammering action on a metal bell. These were very cheap, very simple and very reliable.

As I understand it then, the voltage difference between the two pairs of batteries, charge capacitor **14** and apply power to the primary winding **16-17** of step-up transformer **15**. This causes a current to flow in this winding, making the core attract the pivot arm of the interrupter in the same way that a relay operates. This breaks the current flow very sharply, causing a powerful back-EMF pulse in the primary winding. The primary winding has a resonant frequency, very considerably lowered by the presence of the iron core which itself is a low-frequency material, and the coil oscillates at its resonant frequency, not for just one cycle but for many cycles. Each of those cycles generates a high voltage in the secondary winding **18-19** and every one of those cycles contributes high-voltage power to the system. That power is fed to three outlets. Firstly, it flows back to provide charging power to one of the battery pairs. Secondly, it adds additional power to the capacitor driving its own primary winding. Thirdly, it provides power for the load which is shown as a series of lamps connected in parallel.

That is just for the first interrupter pulse. The broken current through the primary winding **16-17** causes its core to cease to be an electromagnet and so it ceases to attract the pivot arm of the interrupter and while that seems very quick in human terms, it is very slow compared to the multiple oscillations ringing in the winding. When the pivot arm returns to its starting position, it establishes the current flow through the primary winding once again. However, the charge on the capacitor powering the primary winding has been boosted by those resonant oscillations in the secondary winding and so is more highly charged than when the interrupter contact opened previously. This process continues repeatedly, providing battery charge and power to the load.

According to Carlos, there is a slight overall drain on the battery system and so, after about an hour, the switches are operated, changing the series-connected batteries to become parallel-connected and the parallel-connected batteries to become series-connected. This timing seems odd as switching the batteries over much more frequently only requires batteries with a much lower capacity.

As we are not familiar with induction coils and interrupters now that solid-state electronics is available, we can get constructional and operational information from that period in the book "Wireless Telegraph Construction for Amateurs" by Alfred Powell Morgan, published in 1913, which is available as a free download from here: <http://www.free-energy-info.tuks.nl/Morgan.pdf>.

For example, the interrupter details include:

"Some means of charging the capacitor is necessary. An induction coil is the most practical for the amateur. The induction coil consists of a primary coil of wire wound around a central iron core and surrounded by a secondary coil consisting of many thousands of turns of carefully insulated wire. The primary coil is connected to a source of direct current which also includes an interrupter to "make" and "break" the current in rapid succession. Every "make" of the circuit and consequent magnetisation of the core, induces a momentary inverse current in the secondary winding, and every "break" and corresponding demagnetisation induces a momentary direct current. Normally, the induced currents would be equal, but by means of a capacitor connected across the interrupter, the circuit when "made" requires considerable time for the current and magnetisation of the core to reach a maximum value, while when broken, the demagnetisation and current drop are nearly instantaneous. The value of the induced electromotive force in a circuit, varies with the speed at which the magnetic lines of force cut the circuit, and so, the induced e.m.f. at "break" becomes high enough to leap across a spark gap.

The formulas connected with induction coils depend on conditions which are never met in actual practice and cannot be relied on. To construct a coil of a given size, it is necessary to use dimensions obtained empirically. Therefore, the amateur should stick closely to the lines or hints given here, or which appear in some *up to date* book on induction coil building.

For a long time, the induction coil was an expensive, inefficient instrument, until wireless telegraphy demanded of it more rigid and efficient design and construction. It was the aim of manufacturers to produce the longest possible spark length with a minimum amount of secondary wire. As a result of this demand, wireless coils are now made with a core of larger diameter and give heavier and thicker sparks. The secondary in this case, is short and uses wire of large cross-sectional area in order to reduce the resistance and minimise the heating.

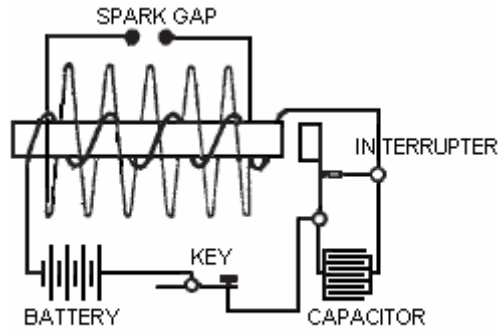

Diagram of an Induction Coil.

No one part of an induction coil may be developed to its maximum efficiency without seriously influencing and lowering the efficiency of the other parts. The following suggestions regarding the construction are given so that they may prove to be a useful guide for the amateur coil builder. The parts will be considered in their natural order of construction.

Core: Some experimenters who are not quite familiar with the principles of magnetism, think that if an induction coil were provided with a closed core like that of a transformer, then the efficiency of the coil would be materially increased. But that is not the case because then the magnetisation and demagnetisation of the iron cannot take place rapidly enough in a closed core when an interrupted direct current is used instead of an alternating current.

The core of an induction coil is therefore always straight. For the same reason, it is never solid but instead is always made up of a bundle of soft iron wires in order that rapid changes in magnetism may take place. The wires are always of as high a permeability (magnetic conductance) as possible so as to create a strong magnetic field. Swedish or Russian iron of good quality is the best as its hysteresis losses are small. The smaller the diameter of the wire, the less will be the eddy current losses and consequent heating, but the permeability is also reduced and the core will not be so effective, as the amount of iron is thereby decreased and the oxidised surface increased. No. 22 gauge wire is the best size for the average core.

Wires of a good quality may be purchased already cut to various lengths. To buy them in this form will save a great deal of the labour required when building a core. If the wires are not quite straight, they may be straightened by rolling them, one at a time, between two boards. It is best to re-anneal the wires. To do this, place the wires in an iron pipe and plug the ends of the pipe with clay. Then lay it in a coal fire until the whole mass reaches a red heat. The fire is then allowed to die out gradually, with the pipe and wires remaining in the ashes until cool. When cool, remove them from the pipe and rub each one with emery paper until bright. After this cleaning, the wires are dipped in hot water and then dried. They are then dipped in a good quality varnish and allowed to dry again.

The varnish provides a resistance to the flow of eddy currents in the core and reduces those losses very considerably. A strong paper tube having an internal diameter equal to the diameter of the finished core is made by rolling the paper on a form and cementing it with shellac. When it is perfectly dry, the tube is removed and the wires packed tightly inside it. The following table gives the core dimensions for practical coils of different sizes:

CORE DIMENSIONS

Spark Length	Core Diameter	Core Length
0.5 inch (12 mm)	0.5 inch (12 mm)	6 inches (150 mm)
1 inch (25 mm)	1 inch (25 mm)	8 inches (200 mm)
2 inches (50 mm)	1.25 inches (31 mm)	10.5 inches (262 mm)
4 inches (100 mm)	1.375 inches (34 mm)	12 inches (300 mm)
6 inches (150 mm)	1.5 inches (38 mm)	14 inches (350 mm)

Primary Winding: The ratio of the number of primary turns of an induction coil to the number of secondary turns, bears no relation to the ratio of the primary and secondary currents. It has been found in practice, that two layers of wire wound tightly on the core, form the best primary. The primary should always be thoroughly covered with shellac or other insulating varnish. Since there is almost no ventilation in the primary, the wire must be large enough to avoid all heating. A table containing the various sizes of primary wires is given here:

PRIMARY WINDINGS

Spark Length	Wire Gauge	Number of Layers
0.5 inch (12 mm)	18 (1.219 mm)	2
1 inch (25 mm)	16 (1.63 mm)	2
2 inches (50 mm)	14 (2.03 mm)	2
4 inches (100 mm)	12 (2.64 mm)	2
6 inches (150 mm)	12 (2.64 mm)	2

In large coils, the inductance of the primary causes a “kick-back” and sparks are liable to pass between the adjacent turns. For this reason, it is always a good idea to use double cotton covered wire and to further thoroughly insulate it by soaking the primary and core in a pan of melted paraffin wax and allowing the wax to harden with them inside it. Afterwards, the pan is slightly warmed to loosen the cake of paraffin and the excess wax removed by scraping with a blunt instrument so as to avoid damaging the wires. Paraffin wax contracts when it hardens and the proper method for impregnating a porous substance is to allow it to soak and become set in it upon cooling.

A good method of reducing the “kick back” as well as the size of the capacitor connected across the interrupter, is to make the primary with a number of turns of smaller diameter wire wound in parallel, the effect being to produce a conductivity equal to a wire of large diameter and at the same time, make a more compact winding of the primary on the core. This method of winding is very desirable in large coils, as it reduces the cross-section of the primary and allows the secondary to be placed nearer to the core where the magnetic field is the strongest.

The primary winding should cover nearly the whole length of the core, since there is no advantage in carrying the core very far beyond the end of the primary as most of the magnetic lines of force bend at the end of the primary winding and return without passing through the extreme ends of the core.

Insulating Tube: The successful operation of an induction coil without breaking down when heavily stressed, depends largely on the insulating tube which separates the primary and the secondary windings. Hard rubber tubes are perhaps the best. A tube may easily be built up of several layers of half inch sheet hard rubber by steaming it so as to soften it, and then wrapping it around a former. The tube should fit tightly on the primary and be about one inch (25 mm) shorter than the core. After the tube is in place, it is poured full of beeswax and rosin in order to fill all interstices and prevent sparks due to the capacitor effect of the windings from jumping from the inside of the tube to the primary.

Secondary: A coil used as a radio telegraph transmitter must have wire of a large cross-sectional area in its secondary, so as to produce a heavy disruptive discharge. Number 34 and number 32 gauges are generally used for small coils and number 30 and number 28 gauge for large coils. Silk covered wire is the usual practice, but enamelled wire is coming into use. Cotton covered wire takes up too much space and has poor insulating qualities.

Enamelled wire is insulated with a coating of cellulose acetate, which has a dielectric strength of about twice that of cotton and it takes up much less room than silk covered wire, giving a great saving in space and a greater number of turns may be wound in the secondary without increasing its mean distance from the core.

When winding enamelled wire, it must be taken into consideration that the insulation of enamelled wire is rigid and has no give. Consequently, to allow for expansion, enamelled wire must be wound more loosely than fibre or silk covered wire. The occasional insertion of a layer of paper in the winding gives room for expansion and does not add greatly to the diameter. The length of the secondary is generally not more than half the length of the core.

Coils producing sparks up to 2 inches (50 mm) in length, may be wound in two sections or in layer windings, but the layer winding is not recommended for coils giving sparks over one inch in length. It is best in a coil of this type, to insert an occasional layer of paper. The paper should be well shellacked or paraffined and be a good grade of linen. It should project about one quarter of an inch (6 mm) from the ends of the secondary as shown in this cross-section:

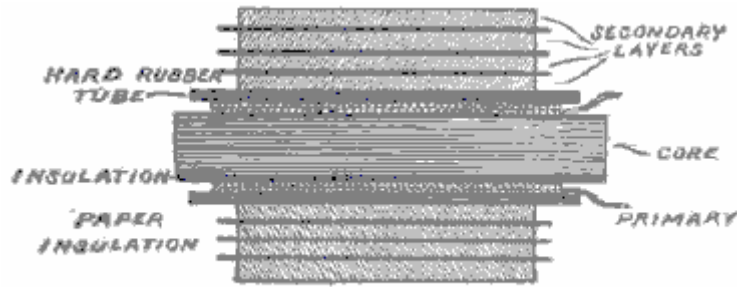
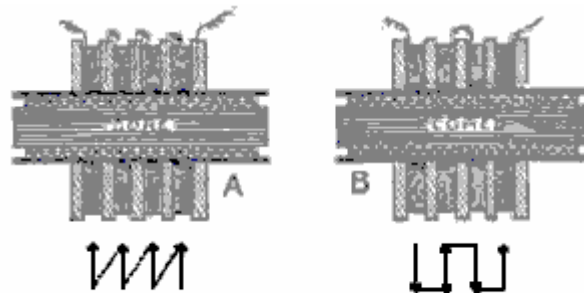

Fig. 28. Layer Winding for Small Coils.

This insertion of paper increases the insulation and reduces the possibility of sparks jumping from layer to layer when the layers are very long. The secondaries of large coils are made up of “pies” or “pancakes” from one eighth (3 mm) to three eighths of an inch (9 mm) in thickness. The “pies” are separated from each other by a triple thickness of blotting paper which has been thoroughly dried and then soaked in melted paraffin. When each “pie” is completed, it is tested for continuity and rejected if not perfect. They are connected in series:



Methods of Connecting the Secondary Sections

If connected as shown in example “A”, where the inside of one section is connected to the outside of the next section, the maximum voltage which can exist between the adjacent sections in this case is equal to the e.m.f. generated by one “pie” and is equal throughout. Connecting as shown in case “B” where the outside of one coil is connected to the inside of the next one, the voltage ranges from zero at the points where they are connected, to twice the e.m.f. developed by any one section. This is the better method and every second coil is turned around horizontally to allow for the reversed direction of current flow.

After the secondary is assembled, the coil should be submerged in an airtight tank containing melted paraffin wax. The tank is then connected to a vacuum pump and the air pumped out. This causes any air bubbles in the windings to be pumped out. After standing for a while, the vacuum is released and the air pressure then causes the bubble gaps to be filled with paraffin wax.

SECONDARY DIMENSIONS

Spark Length	Wire Gauge	Amount required	No. of sections	Length (1 inch = 25.4 mm)
0.5 inch (12 mm)	36 (0.193 mm)	0.5 lb (0.227 Kg)	1	3 inches
1 inch (25 mm)	34 (0.234 mm)	1 lb (0.454 Kg)	2	5 inches
2 inches (50 mm)	34 (0.234 mm)	2.5 lb (1.134 Kg)	4	7 inches
4 inches (100 mm)	32 (0.274 mm)	8 lb (3.629 Kg)	12	8.5 inches
6 inches (150 mm)	32 (0.274 mm)	12 lb (5.443 Kg)	20	10 inches

It should be noted that the very experienced Alfred Morgan flatly contradicts the standard theory of symmetrical transformer operation when he states that “the ratio of the number of primary turns of an induction coil to the number of secondary turns, bears no relation to the ratio of the primary and secondary currents”. That is a highly significant statement.

Carlos Benitez also produced another very clever design, still using four batteries and a very slow switching rate, although no longer using the series and parallel switching which we think of as the Tesla Switch. In this design, he shows a remarkable high-frequency power-gain system where 400 watts of input power produces 2400 watts of output power (COP=6):

Carlos Benitez Patent GB 121,561 24th December 1918

New Process for the Generation of Electrical Energy

I, Carlos Benitez, Civil Engineer, of 141, Ocampo Street, in Guadalajara, Mexico, do hereby declare the nature of this invention and in what manner the same is to be performed, to be particularly described and ascertained in, and by, the following statement:

This invention relates to a new utilisation of the high frequency currents or electrical oscillations, by means of which, a constant production of electrical energy can be secured, under unusually simple, economic and practical conditions.

Such results are attained by means of the procedure disclosed in present applicant's English Patent specification No. 14,311, filed on October 9th, 1915, but in order to obtain a better utilisation the high-frequency currents and the automatic operation of the mechanisms employed in such a procedure, I have invented a novel arrangement of parts from which is derived several other advantages that will be here described and set forth.

Two batteries are used, one of which has already been charged. This charged battery discharges through a circuit which utilises the greater part of this power and the remainder drives an oscillating circuit connected to the second battery. This oscillating circuit contains a rectifier which directs the electrical oscillations in such a manner that they are forced to pass constantly through the second battery from the positive to the negative terminal. As the number of oscillations per second in that circuit can be varied at will, the current intensity developed by those oscillations can be regulated so that the second battery is fully charged in the same period of time during which the first battery is discharged. Therefore, it is only a matter of reversing the connections to the two batteries in order to obtain the continuous production of electrical energy.

The invention is illustrated here:

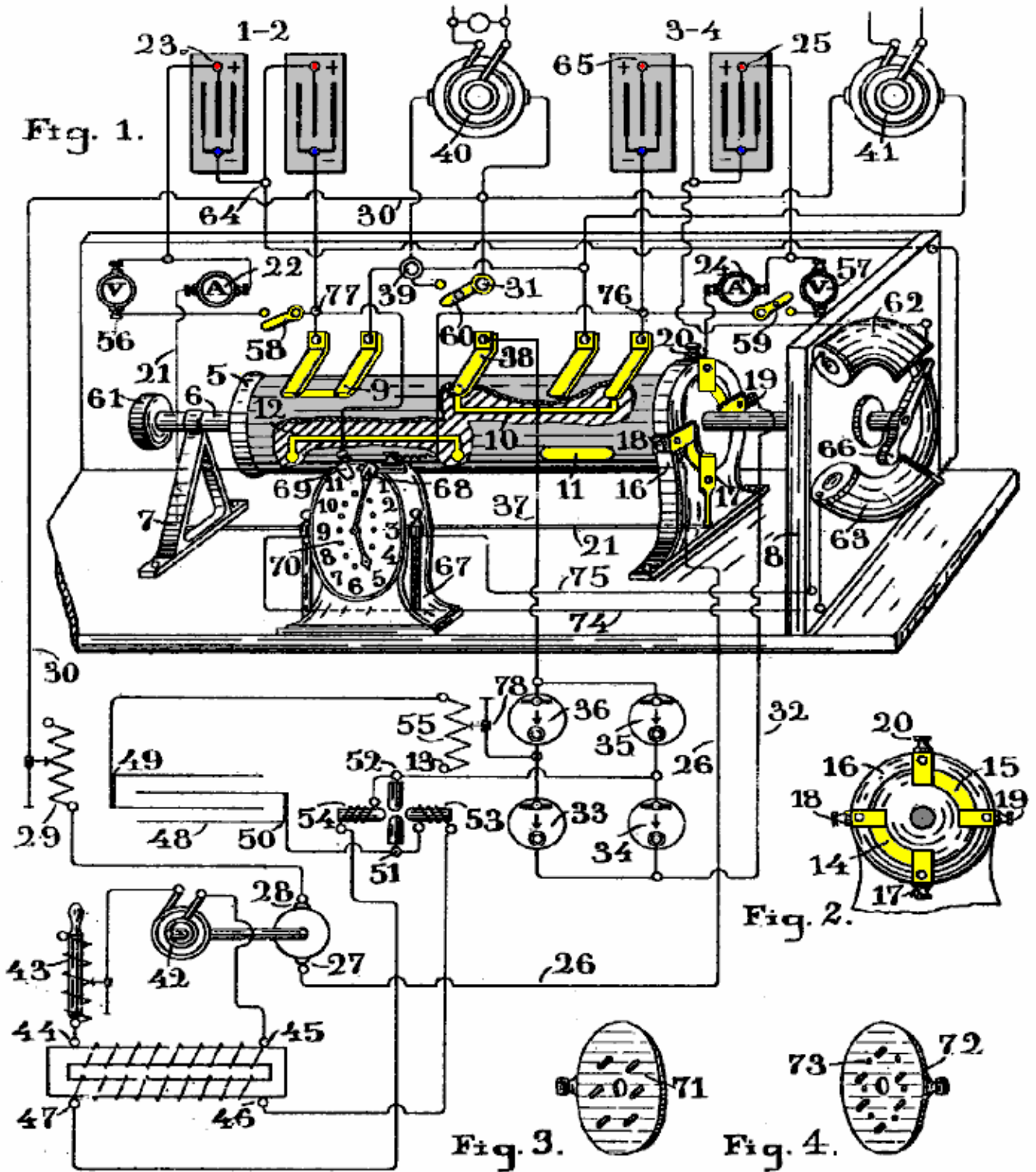

This circuit shows the circuit connections of the arrangement and a perspective view of a commutator. Figure 2 is a lateral view of a part of the same apparatus, and figures 3 and 4 are parts of the same machine, whose location and use will be explained later.

The figure shows two battery banks 1 & 2 and 3 & 4, both of which are connected in series. Their positive poles 23 and 25 are connected to terminals 17 and 20 of the commutator, through the ammeters 22 and 24. The commutator is a cylinder 5, mounted on a rotating shaft 6, which passes through two supports 7 and 8. The cylinder is provided with conductive paths 9, 10, 11 and 12 insulated from the cylinder 5. It also has conductive paths 14 and 15 which can be seen better in Figure 2 and which make contact with brushes 17 & 18 and 19 & 20, properly insulated and fixed to ring 16 which encircles cylinder 5 and is fastened to the base of the apparatus. These brushes connect to the batteries and terminal 17 is connected to the positive pole 23 of battery 1 & 2. Terminal 20 is connected to the positive pole 25 of battery 3 & 4 through ammeter 24. Terminal 18 connects through wire 26 to terminal 27 of a DC motor whose terminal 28 connects through the variable resistor 29 and wire 30 with terminal 31 of the commutator. Finally, terminal 19 is connected through wire 32 to terminals 33 and

34 of an electrolytic rectifier whose other two rectifiers **35, 36** connect via wire **37**, to brush **38** of the commutator.

This apparatus is also provided with terminal **39** which is alternately connected to the negative poles of the batteries through the brushes which can be seen in the figure, in contact with cylinder **5**. Under these conditions, the apparatus **40** and **41**, which are employed to provide a practical output independent of the running of the "plant", and which are connected to both terminals **31** and **39**, will be alternatively in circuit with the discharging battery, and thus, part of the power produced by the battery discharging, is used by this apparatus without impairing the normal running of the whole mechanism, as explained below.

On the other hand, an alternator **42**, is coupled to the motor **27-28**, which in this manner can be rotated at the speed needed to attain the desired frequency. Both terminals of the alternator are connected through the inductive resistance **43**, with the poles **44, 45** of the primary winding of a step-up transformer, whose secondary winding **46, 47**, connected to capacitor **48**, will finally produce the high-voltage alternating currents needed to charge the capacitor. However, the use of this motor and alternator is not essential in this process as the same results could be attained if the primary **44, 45** of the transformer, were connected through an ordinary interrupter to the discharging battery.

The terminals **49, 50** of capacitor **48** are connected through an arc lamp of the Poulsen type **51, 52**, or through an adequate spark-gap with the rectifiers **33, 34, 35** and **36**, and with the battery under charge (**3 & 4** in this case). Extending into the arc chamber are the poles of a strong electromagnet, the coils of which are in series with the arc, so that their excitation current is the arc current.

Connected in this manner, the strong magnetic field which exists between the poles of the magnets, acts on the arc, and owing to this action, combined with the influence of the voltage developed by the secondary of the transformer **46, 47**, it happens that this action and influence being about equal in value, are each of them alternately greater than the other, so that the voltage across the arc automatically rises and falls. Therefore, when the action of the magnetic field is greater than the voltage produced by the secondary winding of the transformer has not enough power to pass across the arc and so the capacitor **48** is charged to a higher voltage. But, an instant later the action decreases in value and the capacitor discharges again across the arc.

On the other hand, owing to the oscillatory nature of the circuit (which is arranged with proper values of capacity, inductance and resistance), the charging and discharging of the capacitor can occur several million times per second if desired, and in this manner, a current of a great number of amperes can be obtained through the oscillating circuit, even with a small amount of electricity stored in the capacitor.

In the same manner, one gallon of water could produce a flow of one thousand gallons per second through a pipe if such a pipe were connected with two different vessels and the gallon of water could be forced through the pipe by a piston which could transfer that gallon of water from one vessel to the other one thousand times per second. Obviously, what can be easily performed with electricity is not so feasible with water.

In other words, the small amount of electrical power taken by the DC motor **27, 28**, appears (with a small loss) at the alternator **42**, and that power is delivered to the transformer primary **44, 45**. Again, the inductive action of this transformer produces at the secondary **46, 47**, a similar amount of power (diminished slightly due to the efficiency of the transformer), and finally, the capacitor is charged with a small amount of electricity which is then converted into oscillatory energy. Obviously, if such electric power, instead of being stored by the capacitor, had simply been rectified and used to charge one of the batteries, such power would produce only a very small effect on the battery and the entire discharge of one battery would never cause the complete charge of the second battery.

Contrary to that, if that same power is stored in capacitor **48**, and that capacitor is properly connected to an oscillatory circuit in which one of the batteries can be joined, and furthermore, if by means of a rectifier, the high-frequency currents produced in such an oscillatory circuit are forced to pass from the positive to the negative pole through the battery, it is obvious to state that it is always possible to secure by these means, the number of amperes required to charge the battery in the available time. That is to say, with a small number of coulombs stored in capacitor **48**, it is possible to produce in the oscillatory circuit, a great number of amperes, if that same small number of coulombs are forced to pass and repass through the circuit, thousands or millions of times per second, just as was explained in the water analogy.

On the other hand, the values of the above named quantities: capacity, resistance, inductance and voltage can be varied within very wide limits, and therefore it is always possible to attain the required conditions in each case, in order to produce a given number of oscillations per second: The capacity of the capacitor can be adjusted to a certain value by increasing or reducing the inter-meshed surface area of its plates. The resistance of the circuit can be adjusted to the required value by varying the length of the arc in the Poulsen lamp, or varying the number of lamps connected in series or parallel in the circuit. The inductance of the circuit can be varied by winding part of the circuit on an insulating frame, in such a manner as to obtain the number of turns required to produce the

desired inductance, and finally, the charging voltage can be regulated by increasing or decreasing the number of turns in the secondary winding of the transformer or by varying the diameter of the wire used in the coil. In order to obtain a better efficiency from alternator 42, it is convenient to use the resonance coil or adjustable inductive resistor 43. By so doing, it is possible to adjust the resistance in order to obtain a state of resonance in the circuit, and in that state, the current produced by the alternator will be in phase with the impressed E.M.F., therefore the effective watts will be a maximum in the primary and secondary circuits.

The variable resistor 29, which is placed in the circuit which connects each battery with motor 27-28, is used to adjust the current of the discharging battery to a fixed value, since it is important to obtain a constant number of revolutions per second of the alternator 42.

The commutator is also provided with voltmeters 56 and 57, and by means of the switches 58 and 59, the circuits connecting both poles of each battery, can be closed and the voltage of the discharging current may be determined when desired. Finally, by means of switch 60 connected across the terminals of the apparatus 40 and 41, the apparatus may be switched off when not required.

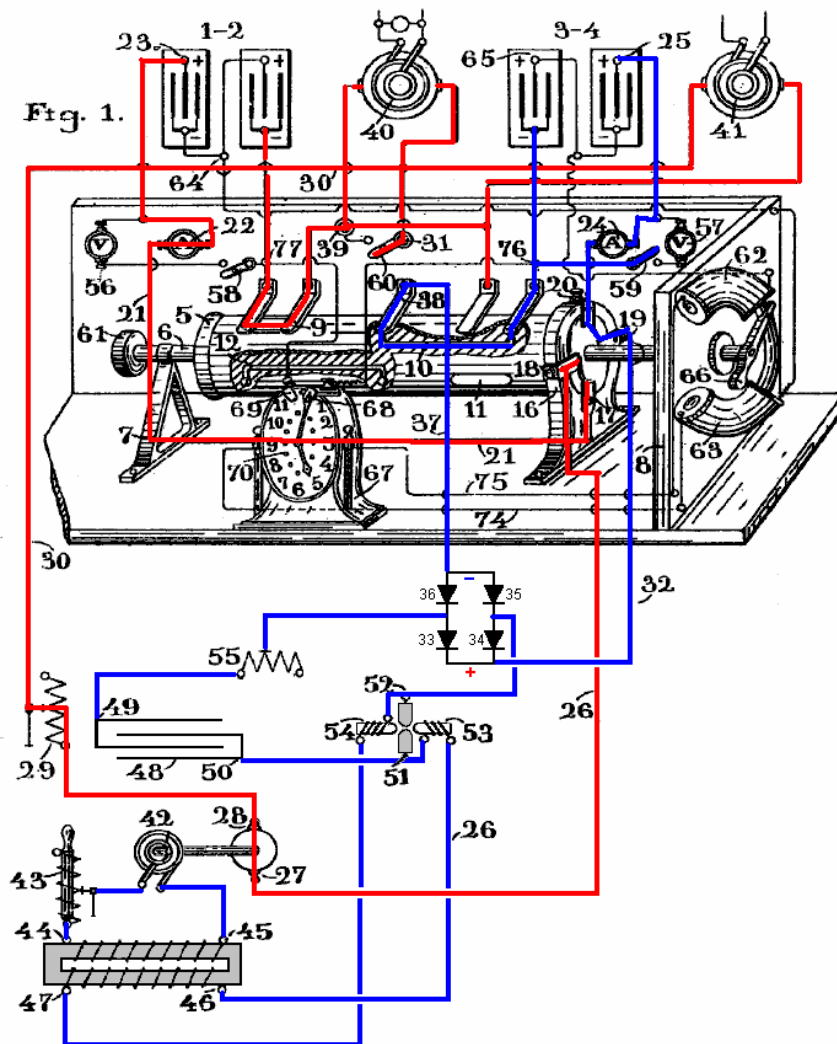

It is easy to understand the whole operation of this mechanism. Suppose initially that battery 1-2 has been charged and that cylinder 5 has been rotated to the position shown in the drawing. Battery 1-2 will immediately discharge via battery terminal 23, ammeter 22, wire 21, contacts 17-18, wire 26, motor 27-28, variable resistor 29, wire 30, rotary transformers 40 and 41, (or through any other apparatus which may be used instead of those transformers in order to use part of the current flowing from the battery), pole 39, and commutator path 9-12, through which the whole discharging circuit is closed.

As a result of this discharge from the battery, the electrical power produced will be dissipated in three ways: A first part is wasted in overcoming the internal resistance of the various components in the circuit. A second part is used to power the DC motor 27-28, and the third part powers the apparatus connected to poles 31-39 of the commutator, that is, the useful equipment powered in addition to the running of the system.

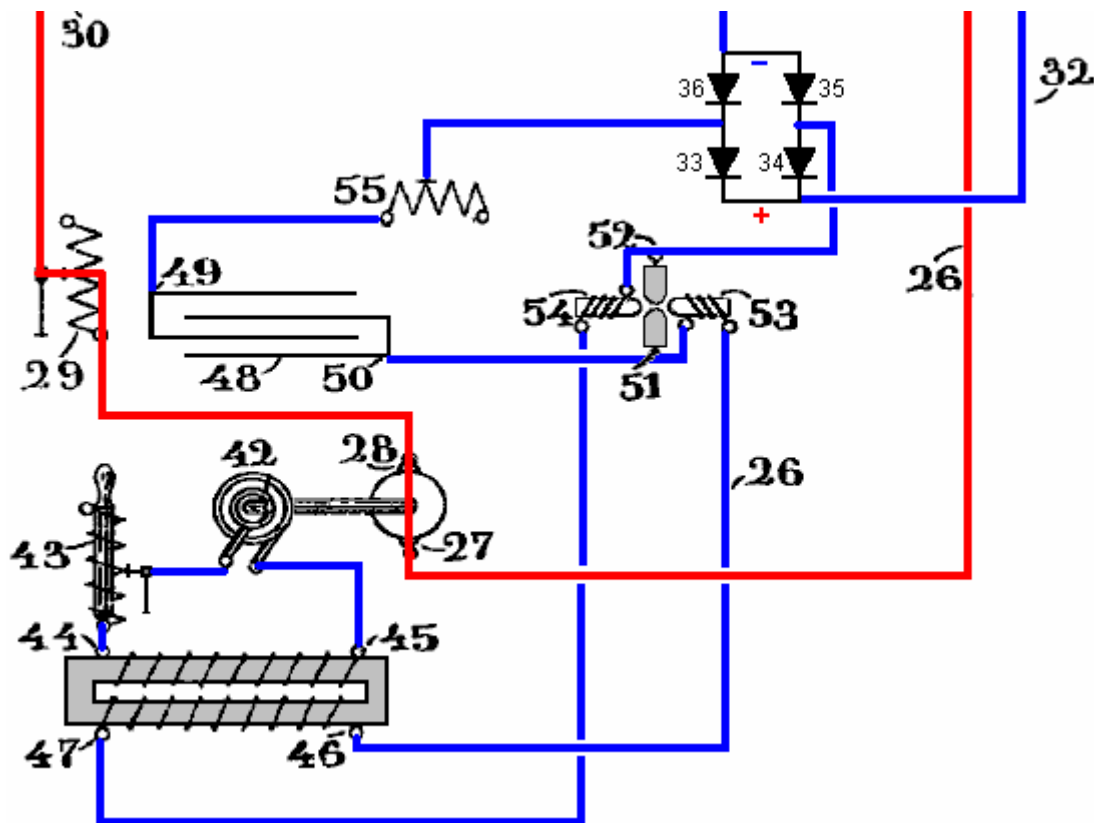

It is well known how the mechanical power developed by the rotary motion of motor **27-28** can be converted to electrical energy by alternator **42**, and in the same manner, it is well known how such electrical energy of low voltage can be transformed into one of high voltage using a transformer, and it is well known too, how such high voltage electrical energy can be converted into oscillatory energy, and how the alternating currents produced by such oscillations can be rectified in order to produce a direct current. However, all such combinations of apparatus arranged to charge a battery while another similar battery is discharging, was perfectly unknown before this invention, and a short consideration of the calculations involved in determining the different values of capacitance, resistance, inductance and voltage required by the various combined circuits of a small working plant of this kind, may be useful in giving an idea of the procedure which can be followed in general practice.

Suppose that both of the batteries are accumulators with a voltage of 60 volts each and a capacity of 40 AHr. Under such conditions, if battery 1-2 discharges at the rate of 40 amperes, it will be fully discharged in one hour. [Please note that this is not so and is only being stated here for discussion purposes. A lead-acid battery will be damaged if discharged at a rate greater than the "C20" rate which is the rated AHr value over a period of 20 hours, and so, a lead-acid battery of 40 AHr should not be discharged at more than $40 / 20 = 2$ amps. Also, batteries are highly non-linear and discharging a 40 AHr battery at 40 amps will result in a fully discharged battery in a lot less than one hour.] The power developed over that time period will be 60 volts x 40 amps = 2,400 watts.

On the other hand, in order to charge battery **3-4** fully in one hour it is necessary to provide a current of at least 40 amps. Suppose that in order to develop such a current, it is desired to take from the power produced by the discharging battery only a portion, say 40 amps x 10 volts = 400 watts. With this objective in view, the DC motor should be arranged so as to create a current of 40 amps causing a drop of 10 volts on the line.

Suppose that the electrical efficiency of the DC motor is 95%, then the desired 400 watt output will not be attained but instead will be reduced to $400 \times 0.95 = 380$ watts.

Then, suppose that the electrical efficiency of alternator **42** is 95% then that will reduce the output to just 361 watts. Then, if this 361 watts is passed to the transformer and that transformer has an efficiency of say, 89%, then the resulting energy output will be further reduced to just 321 watts, and that is the amount of power passed to the oscillating circuit in order to obtain the required 40 amps of current.

Now, suppose that the frequency of alternator **42** is 500 Hz. As is well known, with an alternating generator, a high voltage is obtainable twice in each cycle and so there will be 1000 voltage peaks per second. As capacitor **48** discharges at the instant of maximum voltage, it will discharge 1000 times per second. Therefore, the quantity of electrical energy which must be stored in it can be calculated as follows: Suppose that the oscillating circuit has an impedance of 15 ohms. As the required current is 40 amps, the required voltage to develop such current will be 40 amps x 15 ohms = 600 volts. But in order to produce 600 volts from the discharge of the capacitor, it is

necessary to get it charged up to 1200 because the average voltage during discharge is $V / 2$.

If the energy produced by the transformer secondary is assumed equal to 321 watts and the voltage required for the charge of the capacitor is 1200 volts, then the current delivered by the secondary will be 321 watts / 1200 volts which is 0.267 amps.

On the other hand, as the frequency of the alternator is 1000 peaks per second, then in one thousandth of a second the secondary has to deliver to the capacitor 0.000267 coulombs which is 267 microcoulombs.

Hence, the capacity of capacitor **48** must be adjusted to store that amount of electricity, and its value can be determined by $Q = K \times V$ where K is the capacity of the capacitor in microfarads when Q is given in microcoulombs and V is the maximum voltage, and so, $K = 267 / 1200$ which is **0.222 microfarads**.

It is also well known that if you want to produce an oscillatory discharge through a circuit, the capacitance, resistance and inductance of the circuit must be arranged so that the square root of $1000 \times L$ millihenrys / K microfarads is greater than the resistance of the circuit in ohms (K being the capacitance of the capacitor).

It has been supposed that the resistance of the oscillatory circuit is 15 ohms. Using 20 ohms in the above equation will allow a suitable value of inductance to be calculated, one which will satisfy the required conditions for the production of the oscillatory discharge in the circuit, and so the inductance in millihenrys is $400 \times K / 4000$ or $400 \times 0.222 / 4000$ which is **0.0222 millihenries**, or equal to 22,200 centimetres of wire.

It is possible to determine the number of oscillations per second which can be achieved in any such circuit, and that is given by $\text{Hz} = 5033000 / \text{the square root of } L \times K$ where L is in centimetres and K is in microfarads. And so, knowing the inductance and the capacitance we get $\text{Hz} = 5033000 / \sqrt{22200 \times 0.222}$ which is **71900 Hz**. That represents 72 oscillations in each of the 1000 sparks per second.

The current strength developed by these oscillations can be determined from the formula below which uses the Voltage **V** in volts, the resistance of the circuit **R** in ohms, the inductance **L** in henrys, and the capacitance **K** in farads:

Current = $V / \sqrt{R \times R + (6.28 \times \text{Hz} \times L - 1 / (6.28 \times \text{Hz} \times K))^2}$ or in our case:

Current = $600 / \sqrt{15 \times 15 + (6.28 \times 71900 \times 0.0000222 - (1 / (6.28 \times 71900 \times 0.0000222)))^2}$

Which works out as 40 amps, meaning that the impedance of the oscillating circuit is equal to the resistance in ohms of that circuit, since the inductive reactance and the capacitive reactance are so combined that the resultant value of the total reactance is equal to zero, and the only voltage required to produce the current of 40 amps is that needed to overcome the ohmic resistance of the circuit which is 15 ohms. This also means that the E.M.F. is in phase with the current, and therefore, the watts are a maximum.

Hence, there can be no doubt that battery **3-4** will be fully charged during the period when battery **1-2** is discharging, especially since the charging current can be further increased at will, even without taking more power from the discharging battery. In fact, it is easy to increase the number of turns in the transformer secondary **46-47** in order to increase the voltage. Obviously, as the amount of power delivered to the primary **44-45** of this apparatus is always 321 watts, if the voltage is increased, the quantity of electricity which the capacitor **49** receives will be reduced accordingly. Consequently, the value of that capacitor must also be reduced and so the number of oscillations per second will also be increased. Finally, by increasing the voltage, the current intensity is increased proportionately.

Therefore, it is always possible to combine, in the manner described, the values of resistance, inductance, capacitance and voltage in the oscillating circuit, so as to obtain the required current strength to fully charge one of the batteries during the period when the other battery is discharging.

Once this battery charging has been attained, if the plant is to continue in operation, then the batteries need to be swapped over by altering their connections to the circuit. To accomplish this, cylinder **5** is rotated until the conductive paths **11** and **12** come into contact with the brushes which are connected to the negative poles of the batteries, and then, battery **3-4** which is fully charged will be connected with the motor **27-28**, and its discharge will now be produced by this path: battery terminal **25**, ammeter **24**, commutator poles **20** and **18** (now connected together due to the rotation of the cylinder **5** through 90 degrees), wire **26**, motor **27-28**, variable resistor **29**, wire **30**, apparatus **40** and **41**, and commutator path **11** which closes the circuit to the negative pole of battery **3-4**.

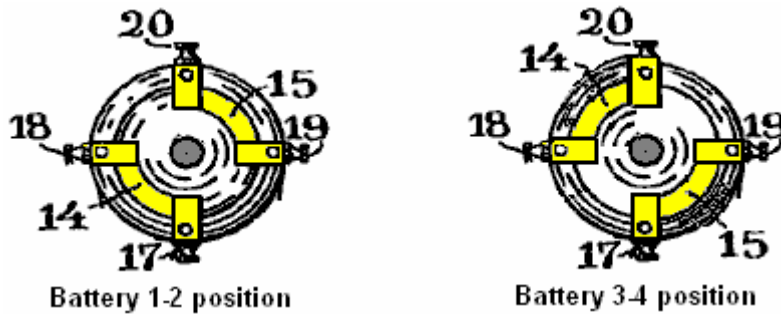

In other words, the motor 27-28, apparatus 40 and 41, and alternator 42, will still be operating in exactly the same way as described above, and in the same manner, the high-frequency currents are still developed, producing the same current intensity which is now passing via terminal 50 of capacitor 48, arc-lamp 51-52, diode 34, wire 32, commutator contacts 19-17, wire 21, ammeter 22, and positive terminal 23 of battery 1-2 (which is now connected to contact 38 of the commutator through path 12), wire 37, diode 36, inductor 55, and capacitor terminal 49; also through duplicate path from capacitor terminal 49, diode 33, wire 32, commutator contacts 19-17, wire 21, ammeter 22, positive terminal 23 of battery 1-2, commutator path 12, commutator pole 38, wire 37, diode 35, arc lamp 52-51, and capacitor terminal 50.

It is obvious to state that this same procedure can be repeated indefinitely by the simple altering of the battery connections from time to time in accordance with the battery capacity and the rate of discharge. Only 400 watts is taken from the discharging battery for battery recharging, leaving 40 amps at 50 volts (2000 watts) available for doing continuous useful work.

The patent continues with a description of how a modified clock can be made to move the commutator once every hour. This is a brilliant 2 kilowatt, self-powered, free-energy design. However, operating the design as described would not be realistic. Batteries nowadays have limited operational lives offering, typically, between 400 and 1000 charge/discharge cycles within the C20 discharge current limits. Exceeding the C20 discharge rate will reduce the battery life by a major amount, that amount being determined by the degree of abuse which the battery suffers. If we ignore that factor and say that our batteries will manage 1000 cycles, at the proposed rate of say, one hour discharge and one hour charging time, then battery replacement is liable to be required in just 500 hours of operation. That is, within three weeks of continuous operation.

The essential, rapid switching of this circuit is performed by the spark-gap but in contrast to that, the commutator switching of the batteries does not require high speed operation. It is feasible then, to replace the commutator with simple solid-state switching and swap the batteries over every second or two. That way, the batteries are never discharged and long battery life can be expected.

Bozidar Lisac's Power-Boosting System.

Recently, a patent application has been lodged on what is effectively the **Ron Cole** one-battery switch and the Tesla Switch. I am including the re-worded patent here. Some experimenters have reported overall battery energy gains with switching speeds of 0.5 Hz or less, which means that in circuits of that type, mechanical switching should give a reasonable switch contact life. This patent has needed a fair degree of attention as the person writing it does not have a full grasp of English and confused the word "load" with the word "charge". Let me say again, that the following patent application is included here primarily for interest sake, rather than being the definitive way of making a circuit of this type.

Patent Application US20080030165

7th February 2008

Inventor: Bozidar Lisac

METHOD AND DEVICE FOR SUPPLYING A LOAD WITH ELECTRIC ENERGY RECOVERY

ABSTRACT

In the invention an electric current circulates from the battery **UB**, through the electric motor **M**, and the diode **D1** charges the capacitors **CA** and **CB**, connected in parallel, which, once charged, are connected in series, giving rise to a difference in voltage in relation to the battery, causing half the charge of the capacitors to be returned to the battery through the diode **D2**, whilst with a new parallel connection, the capacitors recharge, this charge being

equal to that which had been previously transferred from the capacitors to the battery, so that by means of the cyclic connection of the capacitors in parallel and series the energy is transferred from the battery to the capacitors and from the capacitors to the battery, thus considerably extending the range of the battery and operation of the motor.

OBJECT OF THE INVENTION

This invention relates to a method and device enabling the electrical energy with which a charge is supplied to be recovered using a self-rechargeable electricity source in which, which by means of a circuit, the current circulating from an accumulator or battery through a load, e.g. a motor, is fully returned to the same energy level, thereby considerably extending its range.

More specifically, two capacitors that are connected cyclically from parallel to serial and vice versa are charged through a motor during the connections in parallel, whilst in series connection, when its voltage doubles, they return the electricity, recharging the battery. This source represents a closed system which does not require an energy supply from the outside, except to compensate for the losses produced, the range of the battery being limited by the number of charges and discharges that the same technically permits.

BACKGROUND TO THE INVENTION

A load, such as an electric motor, is connected to a battery or accumulator with a certain charge, which will be progressively discharged by it, this discharge being directly proportional to the connection time and to the current circulating through the motor. It is therefore necessary to supply fresh energy from an external source to recharge it. Systems that enable the energy consumed by the load to be reused are not known in the state of the art.

DESCRIPTION OF THE INVENTION

A first aspect of the invention relates to a method for supplying a load with recovery of electrical energy, which comprises supplying a load with electrical energy deriving from the first electrical energy accumulator, and returning at least a proportion of that electrical energy after it passes through the load to the first accumulator for the purpose of recovering the energy supplied.

The electrical energy, after passing through the load, is recovered by second electrical energy accumulator, from where it is transferred to the first accumulator, giving rise to cyclic transfer of electrical energy between the first and second energy accumulators.

The recovery of energy from the second accumulator and transfer to the first accumulator may be achieved without passing the energy through the load. In another alternative implementation, the energy is recovered from the second accumulator and passed to the first accumulator through the load, in which case the polarity of the load is reversed during the recovery of energy through the load.

The transfer of energy is brought about by cyclically connecting two or more electrical energy accumulators between parallel and serial connections.

A second aspect of the invention relates to a device for supplying a load with recovery of electrical energy, which comprises a first electrical energy accumulator and a second electrical energy accumulator, where the load is connected between the first and second accumulators. The device may be provided in one embodiment with a unidirectional connection device, for example, a diode which is connected in parallel to the load, causing circulation of the electrical energy recovered after passing through the load, and via which the electrical energy is returned to the first accumulator.

The first electrical energy accumulator may be a battery. The second electrical energy accumulator might be two or more capacitors with switching to cyclically connect them between parallel and serial connection configurations.

The invention constitutes a self-rechargeable source of electrical energy which enables the range of a battery to be considerably extended so that the current circulating from the same through a motor charges two capacitors connected in parallel, up to the voltage level of the battery, by means of contacts. These capacitors, once charged, are connected in series, producing double their voltage, and they then return the energy to the battery, thereby extending its range. Once the losses have been compensated for, the duration of the extended range depends on the charging and discharging properties of the capacitors.

The existence of the difference in voltage between the battery and the capacitors connected both in parallel and in series, and which give rise to the displacement of energy from the battery to the capacitors and vice versa, is

used to supply the motor connected between the battery and the capacitors, comprising the self-rechargeable source of electrical energy.

When connected in parallel, the capacitors are charged through a motor and a diode, and when connected in series, they are charged through another diode, **the voltage of the motor being half that of the battery**. On the other hand, if the motor is connected between the battery and the serially-connected capacitors, the latter, which are charged in parallel through a diode and are discharged by means of the motor and the other diode, will supply the motor with a voltage equal to that of the battery, whilst a capacitor connected in series to the winding of the motor guarantees its operation without loss of power.

Instead of the two capacitors, two batteries connected in series and another two connected in parallel may be used, between which batteries a motor is connected, the current circulating in this case from the batteries connected in series through the motor to the batteries connected in parallel. The serially-connected batteries are then connected in parallel, by means of switching contacts, and the other two parallel-connected batteries are then connected in series, reversing the direction of the current, whilst the connections of the motor are inverted by means of the simultaneous switching of other contacts in order to maintain the polarity and direction of rotation of the motor.

In one possible embodiment of the invention, another two capacitors and a transformer with two primary windings, or a motor with two windings are added to the device previously described, each pair of capacitors cyclically switching from parallel to serial connection and vice versa so that during the parallel connection cycles, two of the capacitors are charged through one of the windings up to the voltage level of the battery at the same time that the other two capacitors are connected in series, double their voltage and are discharged by means of a second winding to the battery.

The reduced level of energy losses brought about mainly by the dissipation of heat and in the capacitors, as well as by the charge factor of the batteries, is compensated for from an external source, and because the sum of the current circulating through a winding of the motor or transformer charging two of the capacitors and the current simultaneously circulating from the other two capacitors through the second winding, recharging the battery, plus the current which is supplied from the external source, is equal to zero, because of the work carried out by the motor or the loads which are connected to the alternating voltage induced in the secondary of the transformer, no discharge of the battery takes place.

DESCRIPTION OF THE DRAWINGS

In order to supplement the description now being given, and with the aim of contributing to a better understanding of the characteristics of the invention, according to a preferred practical embodiment, a set of drawings is attached as an integral part of this description, in which, for informative and non-restrictive purposes, the following is shown:

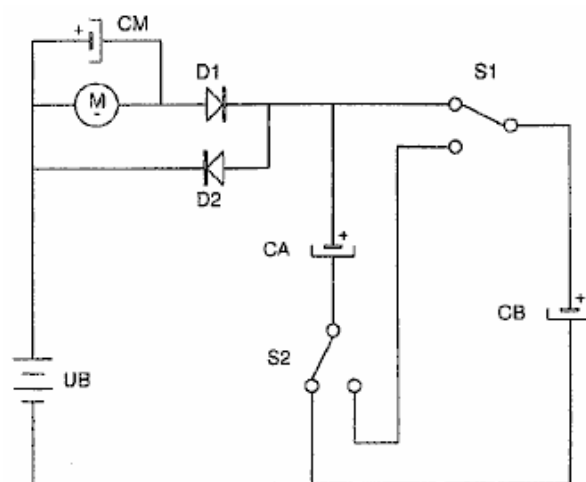

FIG.1

Fig.1 shows a practical circuit in which, by means of switching, two capacitors connected in parallel are charged from a battery through a motor and a diode, and after the contacts are switched, they are connected in series, thereby discharging the battery through another diode.

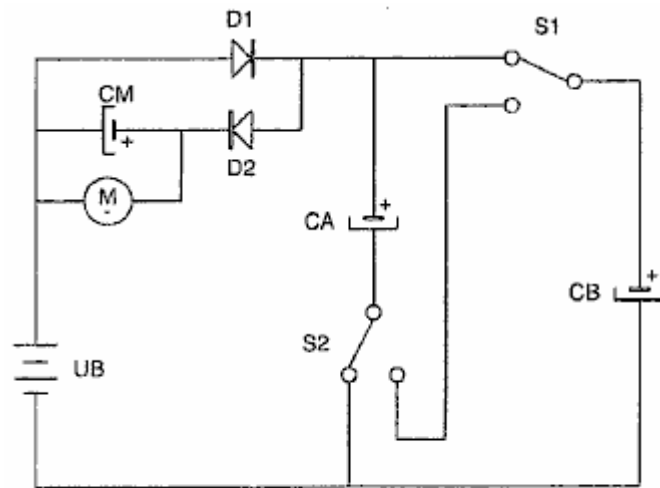

FIG.2

Fig.2 shows a practical circuit in which, through switching, the two capacitors are connected in parallel and are charged from a battery through a diode, and after the switching of the contacts they are connected in series, thereby charging the battery through the motor and the other diode.

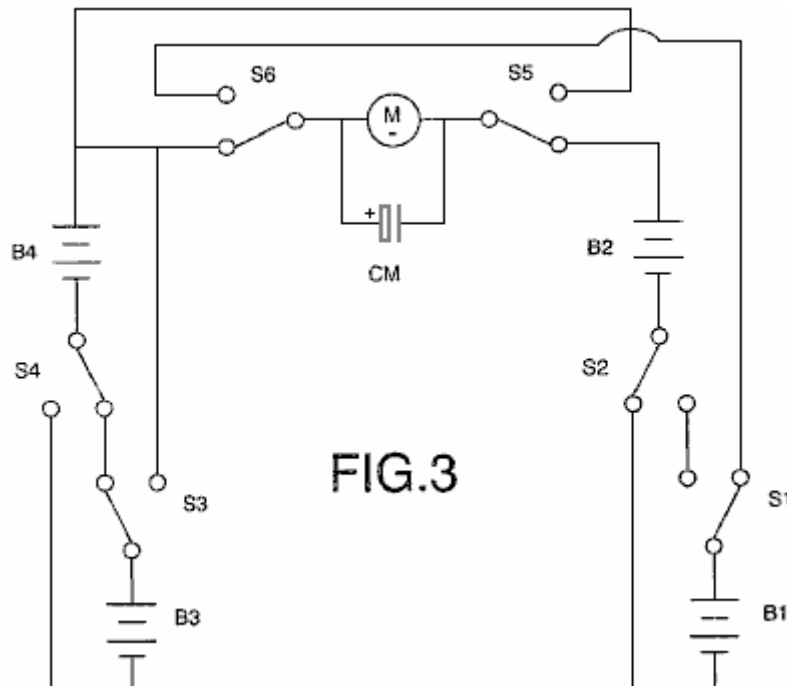

FIG.3

Fig.3 shows the connection of the two batteries in series, connected through a motor to another two batteries connected in parallel, and which, by means of contacts, switch alternately, this giving rise to effects similar to those described in relation to the use of the capacitors.

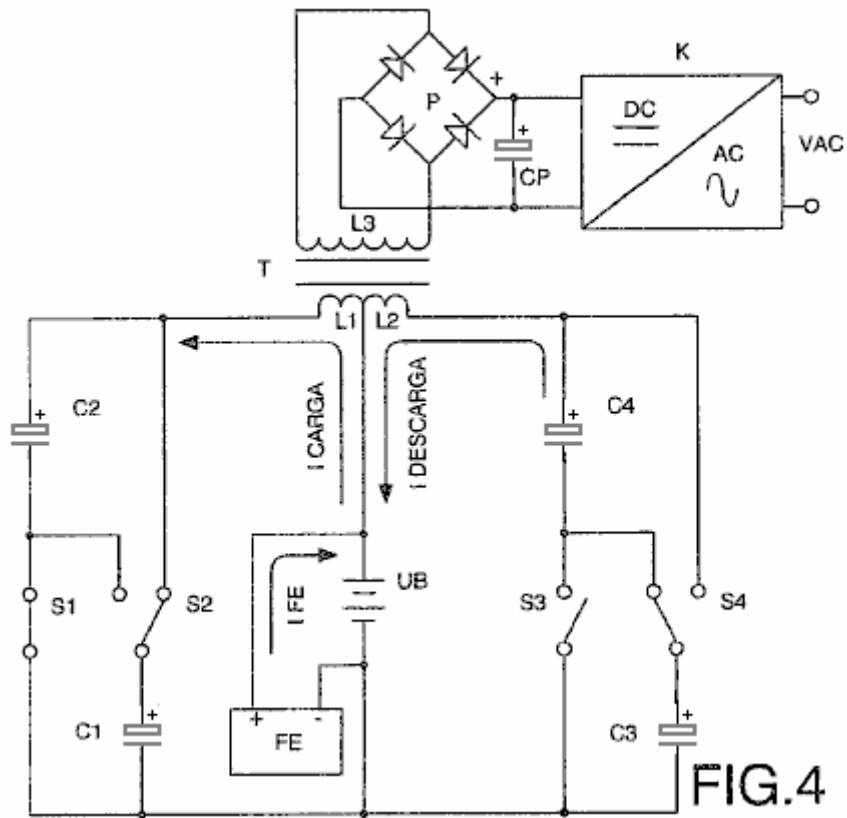

Fig.4 shows the electrical diagram corresponding to the connection between the battery and the two pairs of capacitors of a transformer with two primary and one secondary winding, in which an alternating voltage is induced which is rectified, filtered and converted to a sinusoidal voltage.

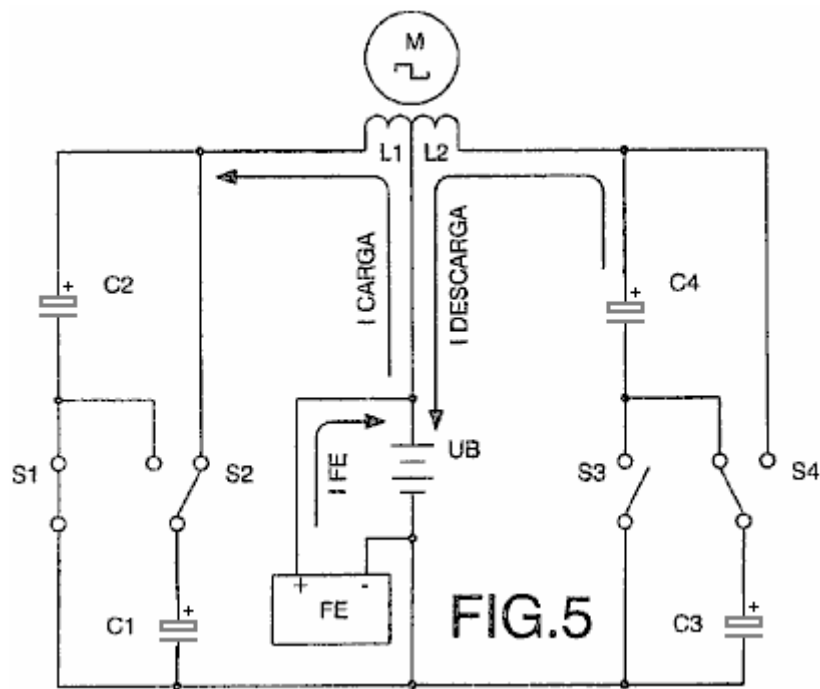

Fig.5 shows the electrical diagram of an alternating current motor with two windings connected between the battery and two pairs of capacitors.

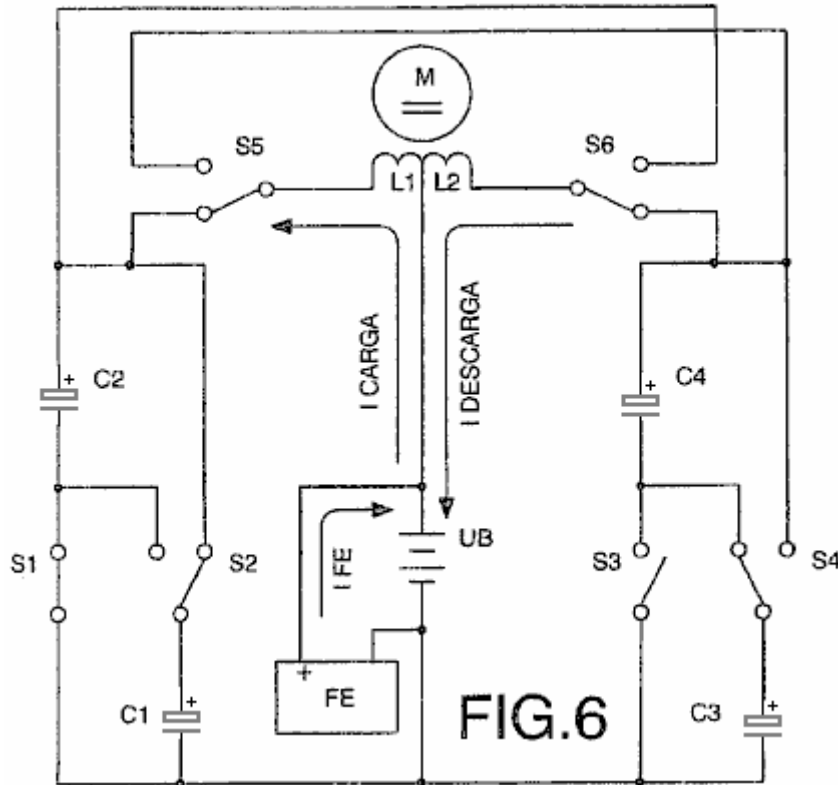
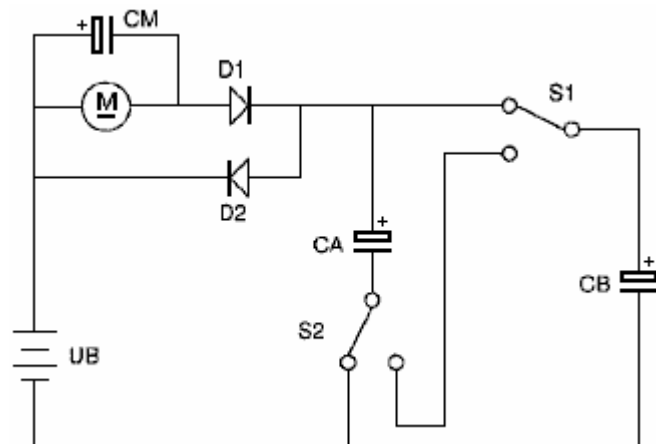

Fig.6 shows the electrical diagram of a direct current motor with two windings connected between the battery and two pairs of capacitors, in which two switch contacts ensure their correct polarisation and direction of rotation.

PREFERRED EMBODIMENT OF THE INVENTION

In a preferred embodiment shown in **Fig.1**, the load consists of a direct current motor **M**, the battery **UB**, and the second accumulator which consists of a pair of capacitors **CA** and **CB**. The capacitors **CA** and **CB** are connected to each other in parallel by means of two switches **S1** and **S2**. These capacitors are charged through the motor **M** and diode **D1** to a voltage level equal to that of the battery **UB**, the charge being $Q = (CA+CB)UB$, and while these capacitors are being charged, the motor **M** is rotating.



When both capacitors are fully charged, they are connected in series by the switch contacts **S1** and **S2**. This produces a voltage which is twice the value of the voltage of the battery **UB**, resulting in the charge which is given by $Q = 2 \times UB \times (CA+CB) / 2$ which is $Q = (CA+CB)UB$, which shows that once charged, the charge **Q** of both capacitors is identical both in parallel and in series.

Diodes **D1** and **D2** ensure that current flow through the motor **M** is only ever in one direction. Immediately after capacitors **CA** and **CB** are connected in series, they return half of their charge through diode **D2**. Switches **S1**

and **S2** then connect the capacitors **CA** and **CB** in parallel. In this arrangement, they start off with half of the battery voltage. They charge immediately, regaining the battery voltage through the motor **M** and the diode **D1**.

By means of repeated cyclic switching of the capacitors **CA** and **CB** from parallel to serial connection mode, the current circulating from the battery **UB** through the motor **M** to the capacitors, and from these to the battery, recharging it and extending its range, constitutes a self-rechargeable source of electrical energy.

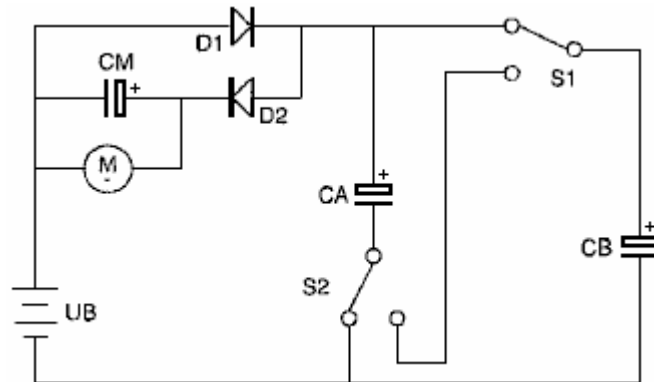

In a second practical embodiment shown in **Fig.2**, the motor **M** is connected between the battery **UB** and the capacitors **CA** and **CB** by means of the diode **D2**. The capacitors are charged directly through the diode **D1** and are discharged through the motor **M** and the diode **D2**, the values of the charges on the capacitors **CA** and **CB** previously described in the example shown in **Fig.1** remain unchanged, the difference in this circuit is that the voltage applied to the motor **M** is the full battery voltage in this case.

The charging rate of the capacitors **CA** and **CB** is determined by the intensity of the current flowing through the motor **M**, to which is connected in parallel, the capacitor **CM** which guarantees that the operation of the motor is maintained at maximum power. It is possible to substitute a battery, preferably a rapid charge battery, for capacitor **CM**.

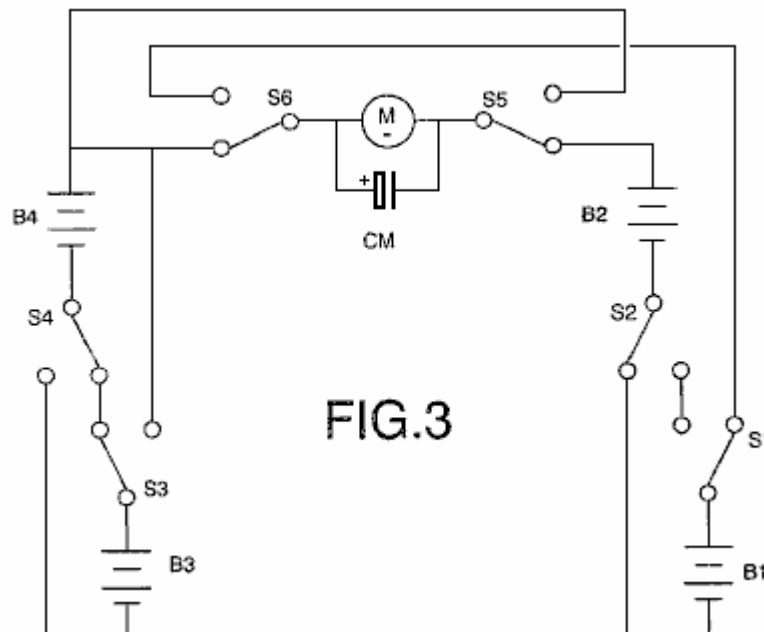

In another embodiment shown in **Fig.3**, the first and second accumulators consist of pairs of batteries **B1**, **B2** and **B3**, **B4**. Therefore, in this embodiment, two pairs of batteries are used instead of the capacitors **CA** and **CB**. Batteries **B1** and **B2** are connected to the switches **S1** and **S2**, and the pair of batteries **B3** and **B4** are connected to the switches **S3** and **S4**. The switches **S1** to **S4**, connect the pairs of batteries with which they are associated, into series or parallel configurations, depending on the position of the switches.

While the batteries **B1** and **B2** are connected in parallel, the other two batteries **B3** and **B4** are connected in series, and the motor **M** rotates as a result of the difference in voltage between the batteries, as it is connected

between both pairs of batteries. At the same time, the current circulating through the motor from the serial connected batteries recharges the two parallel-connected batteries. The switches **S1** to **S4**, which connect the batteries **B1** and **B2** in series and the batteries **B3** and **B4** in parallel then switch, thus reversing the direction of the current flow, and at the same time, the switches **S5** and **S6** change positions in order to maintain the correct polarity for the motor and its direction of rotation.

The two capacitors and the batteries may be switched by means of any mechanical, electromechanical, electrical, electronic or other element that meets the conditions described with the purpose of obtaining a self-rechargeable electrical energy source. These switching operations may be controlled by any known method, for example, a programmable electronic circuit.

In the preferred embodiments previously described, the load consists of a direct current motor, but as an expert in the field may understand, the load may also consist of any type of resistive (?) and/or inductive load.

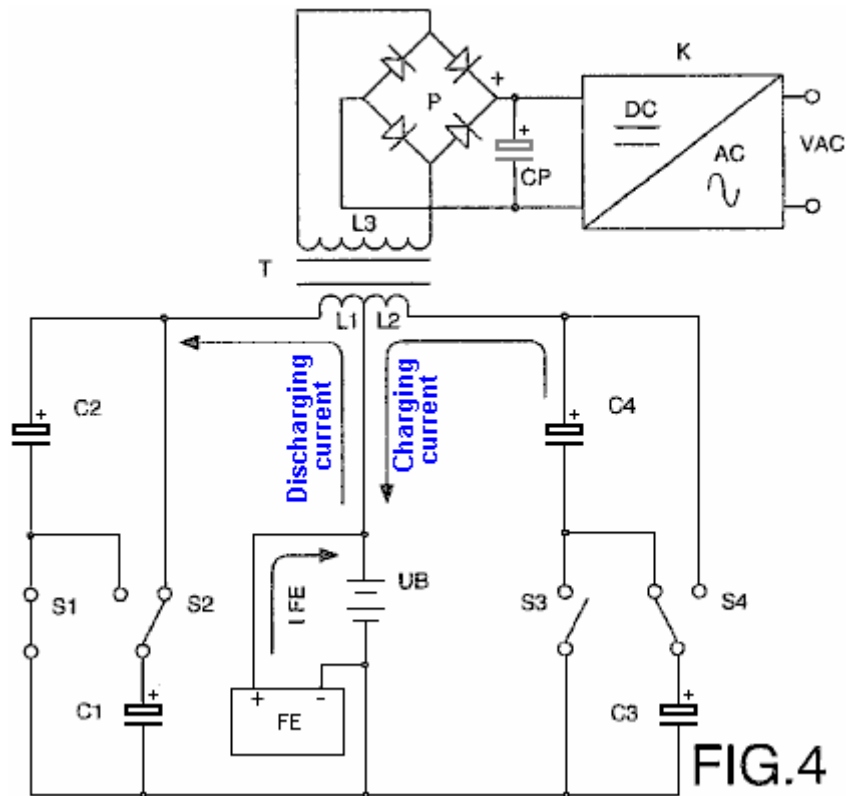

Another preferred embodiment is shown in **Fig.4**, where a transformer **T** with two primary windings **L1** and **L2** is connected between the battery **UB** and the two pairs of capacitors **C1** and **C2**, plus **C3** and **C4**, causing the two capacitors **C1** and **C2** to switch their connections from parallel to serial and back again by means of the contacts **S1** and **S2**, and causing the capacitors **C3** and **C4** to switch by means of contacts **S3** and **S4**, so that during the cycles of connection of the capacitors **C1** and **C2** in parallel, the latter are charged via the winding **L1** up to the voltage level of the battery, whilst at the same time the capacitors **C3** and **C4** are connected in series and provide double their voltage, the battery being discharged by means of the winding **L2**, in which case the charging and discharging currents to circulate in the same direction. On the other hand, during the cycles of connection in parallel of the capacitors **C3** and **C4**, which are charged through the winding **L2** up to the battery voltage level, the capacitors **C1** and **C2** are connected in series to provide double their voltage and are discharged into the battery through the winding **L1**. The direction of the charging and discharging current therefore changes, thus inducing in the secondary winding **L3** an alternating voltage whose frequency depends on the speed of switching of the contacts mentioned, and after being rectified by means of the bridge of diodes **P** and filtered by the capacitor **CP**, the resultant DC voltage is converted to a sinusoidal voltage by means of a circuit **K**.

The connection in parallel of one pair of capacitors and the connection in series of the other pair take place at the same time. Therefore the sum of the current circulating from the battery through one of the windings, charging two of the capacitors, and the current circulating from the other two capacitors through the other winding to the battery, is approximately zero.

From an external energy source **FE** the minimum energy losses caused essentially by dissipation of heat and in the capacitors, as well as by the charging factor of the battery, are compensated for, with the result that the sum

of the current circulating from this source external to the battery and the charging and discharging currents of the capacitors is equal to zero. Therefore the battery is not discharged and its range does not depend on the work developed by the motors or the loads connected to the secondary winding **L3** of the transformer **T**, since the greater the power of the loads, the higher the intensity of the charging and discharging currents of the capacitors.

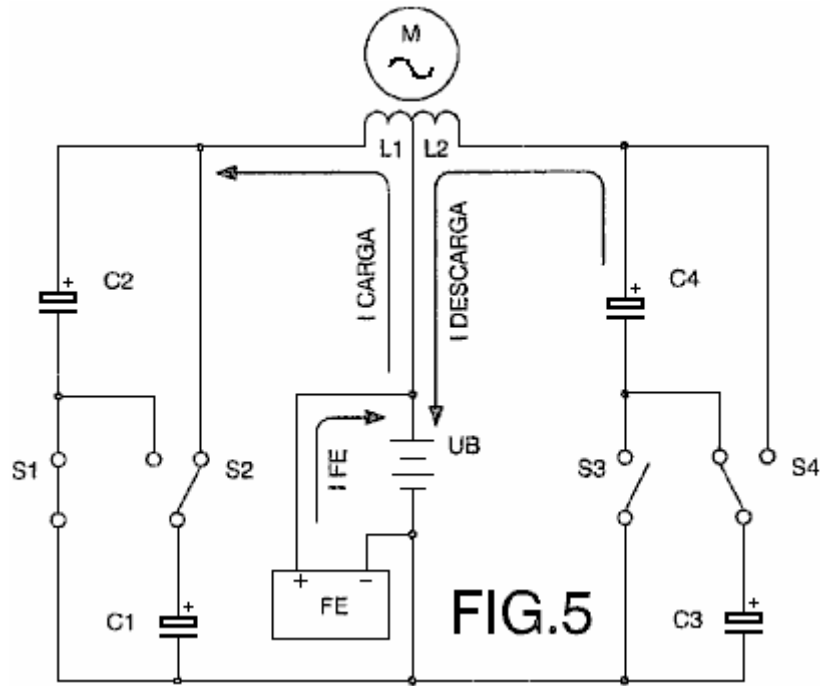

Fig.5 shows another embodiment in which an alternating current motor **M** is connected to two windings **L1** and **L2** so that during the connections in parallel of the capacitors **C1** and **C2**, the latter are charged by means of the winding **L1** at the same time that the capacitors **C3** and **C4**, connected in series, are discharged by means of the winding **L2** to the battery **UB**, the charging and discharging current circulating through the windings in the same direction. The capacitors **C1** and **C2** are then connected in series and the capacitors **C3** and **C4** are connected in parallel. The direction of the charging and discharging current of the capacitors is therefore reversed, thus producing at terminals of the motor an alternating voltage with a frequency that depends on the speed of switching of the contacts. The energy losses caused are compensated for from an external source **FE**, the sum of the current circulating from this source to the battery and the currents circulating through the two windings during charging and discharging of the capacitors being equal to zero. The battery is therefore not discharged as a result of the work developed by the motor.

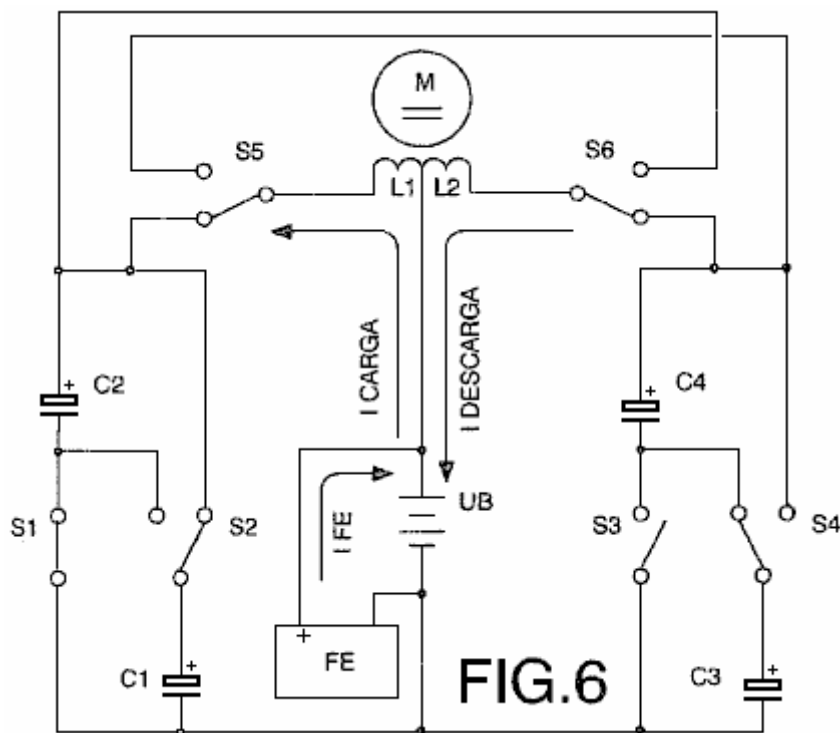

Fig.6 shows the connection of a direct current motor **M** to two windings **L1** and **L2** between the battery **UB** and the two pairs of capacitors **C1** and **C2** plus **C3** and **C4**, so that during the connections in parallel two of the capacitors are charged by means of the winding **L1**, and during the simultaneous connections in series, the other two capacitors are charged by means of the winding **L2** to the battery. Coinciding with the switching of the contacts **S1**, **S2**, **S3** and **S4**, which connect to each pair of capacitors from parallel to serial and vice versa, the contacts **S5** and **S6** switch, polarising the windings of the motor so that the charging and discharging currents of the capacitors circulate in the same direction, producing a direct voltage. The sum of the current supplied from the external source **FE** and the charging and discharging currents of the capacitors is equal to zero, and thus there is no battery discharge.

Bob Boyce's Toroid.

Consider also, Bob Boyce's very effective pulsed toroid system. As the waveform fed to the toroid has to have very sharp rising and falling voltages, the toroid needs to be able to handle very high frequency signals, far higher than the number of pulses per second fed to the toroid. If the rising edge is very sharp (and it needs to be so fast that it won't show on a 150 MHz oscilloscope), then as far as the toroid is concerned, there may be a similar falling edge one nano second later and so it needs to be able to respond to that sort of frequency. Consequently, the material and the windings need to be selected very carefully.

The toroid is a 6.5 inch iron-dust unit from MicroMetals, part number "T650-52" and it can be purchased through their web site: <http://www.micrometals.com/pcparts/torcore7.html> and it can be purchased in small quantities via their "samples requests", which can be submitted at http://www.micrometals.com/samples_index.html

The Micrometals T650-52 Toroidal Core

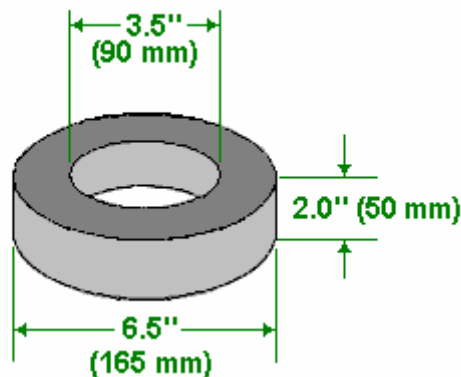

There are four windings made on this core. The wire chosen to wind the transformer is most important. Bob uses **solid** teflon-covered silver-plated copper wire. It is very important that this wire is solid core and **not stranded** as stranded wire does not work here (due to the generation of inter-strand, phase-differential induced eddy currents). At this time, a supplier of this wire is <http://www.apexjr.com>.

Before any winding is done, the toroid is given a layer of the yellow 1P802YE winding tape available in 3" rolls, both the 1" and 2" widths from: <http://www.lodestonepacific.com/distrib/pdfs/tape/1p802.pdf>. It is very important to avoid using fiberglass winding tape anywhere in the construction of this wound toroid. Bob comments on this as follows: "Big warning here !!!! **DO NOT USE FIBERGLASS WINDING TAPE !!!!** A big box of 3M winding tape was ordered by accident so I tried it to see if it would work. It not only suppressed the acousto-resonance response of the entire wound toroidal core, but for some strange reason it also caused the electrostatic pulse response of the secondary to **reverse polarity** as well as reducing the signal amplitude to a mere 10% of what it was !! It totally negated the benefit of the teflon insulation".

Having covered the toroid with a layer of the 1P802YE winding tape, the secondary winding is made. Again, it is very important that the teflon-covered, silver-plated solid copper wire is used. This is not a system which provides COP>1 performance if any old components are thrown together carelessly during the building process.

The winding turns must be evenly spaced where they fan out from the center of the core. They are tightly packed side by side in the centre opening and they must be wound tightly and the gaps between adjacent turns along the outer edge must be exactly the same. This is not to make the winding look "pretty" but if this is not done, then it will cause magnetic field errors that will lower the overall efficiency when the toroid is being used.

The secondary winding is made using 16 gauge wire which covers the entire length of the toroid as shown here:

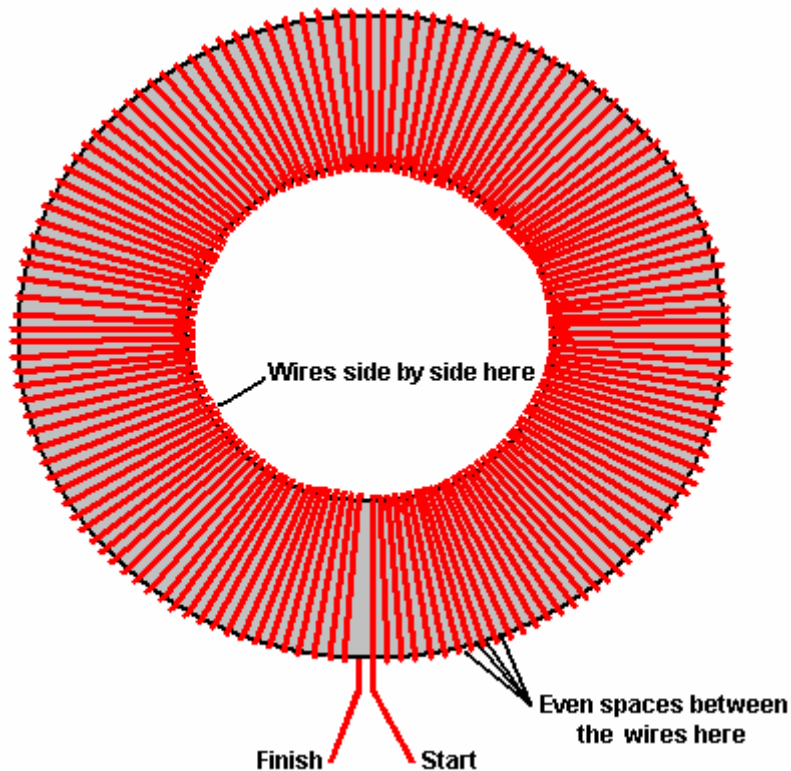

If the spaces between the wires are not quite even, then the turns can be pushed into exactly the right place. It is sometimes convenient to use two-inch lengths of plastic strimmer line placed between the turns in order to get the spaces between the turns exactly the same. These can be held in place with a strip of the yellow winding tape:



The picture above has been taken to show what a partially prepared secondary winding looks like when its windings are being moved into their exact positions. When a section of the windings has been spaced accurately, the triangular gaps between the evenly-spaced turns are filled in with beeswax, made pliable using a heat gun. A plastic bottle pushed into the central hole can be helpful when doing this filling. When the beeswax has hardened on both sides of the toroid, the process is then repeated for the next group of turns.

When the winding is complete, with even spacing of the turns and the gaps filled with beeswax, the whole of the toroid is then covered with a layer of the yellow winding tape, as shown here:



So, to recap: the toroid is wrapped in tape, the secondary winding completed, extending the entire way around the toroid, the windings carefully spaced out so that the gaps around the outer edge of the toroid are exactly equal, the winding gaps filled with beeswax, and then the toroid covered with a layer of the yellow tape. There will normally be anything from 127 to 147 turns in the secondary winding due to manufacturing tolerances in the insulation of the wire and so the overall wire length will be about 100 feet.

The primary windings are now wound on top of the tape layer covering the secondary winding. As with the secondary, the direction of the turns is very important.

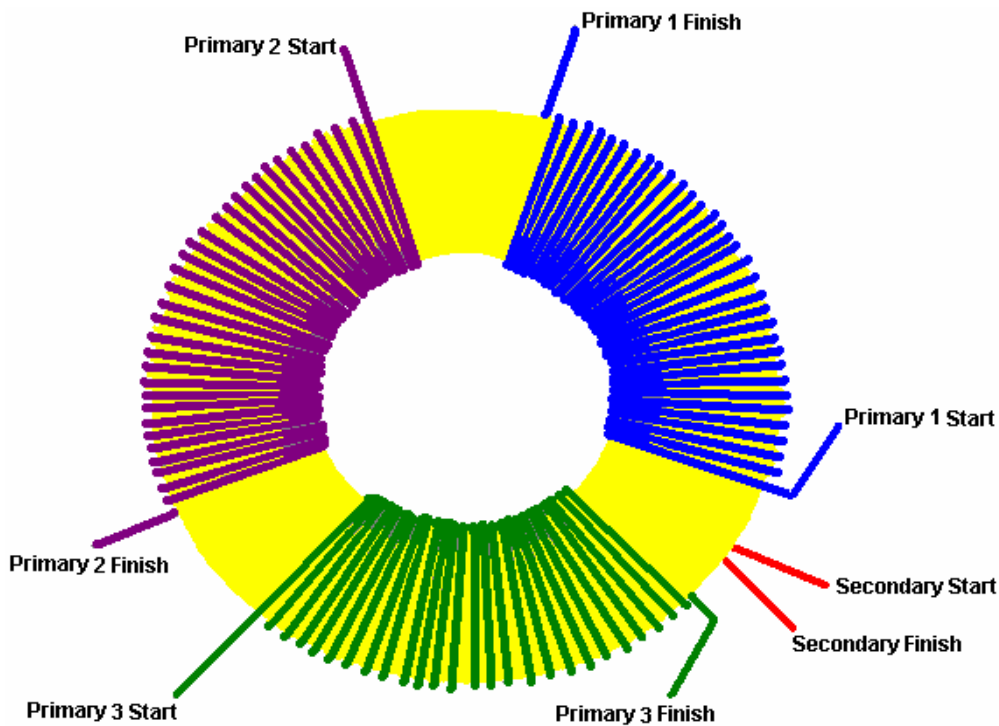

Please note that every winding starts by passing **over** the toroid and then being brought up on the outer side ready for the next turn. Each of the following turns proceed in a counter-clockwise direction, and finishes by passing **under** the toroid. Every winding is created in this way and the quality of workmanship is very important indeed when making these windings. Each winding needs to be tight and positioned exactly with turns touching each other in the centre of the toroid and positioned on the outer edge with exactly equal spaces between each turn. Your construction work **has** to be better than that of a commercial supplier and needs to reach the quality demanded by the military.

The three primaries are wound on top of the tape which covers the secondary winding. These three primary windings are spaced out equally around the toroid, that is, at 120 degree centres and the leads of the secondary winding are taken out through the gap between two of the primary windings and **not** taken out through the middle of a primary winding. As with the secondary winding, the primary winding turns are spaced out exactly, held in place with beeswax, and then tightly taped over. The primaries can have more than a single layer, and they are

wound with the same direction of winds as the secondary, and with the same care for exact turns spacing as needed for the secondary winding. Tape the entire core well with tightly-stretched PVC electrical tape after winding, to ensure that the primary windings do not move and then add an outer layer of the winding tape.

This toroid pulls in additional energy from the immediate environment when driven by very high quality voltage pulsing applied to each of the three primary windings. The full details of this system have not yet been disclosed, but Bob has said in open forum that he has demonstrated his toroid being pulsed with the secondary not connected to anything and the output is triple the current at twice the input voltage, with is COP=6. When the ends of the secondary are joined together the output current doubled, giving COP=12, that is, twelve times as much power output as the input which Bob had to supply to get that output. This is, of course, not a case of energy being created (which is not possible) but instead, it is a case of eleven times the input power being drawn in from the surrounding environment.

I have never seen the circuitry for this, but it may be as shown here:

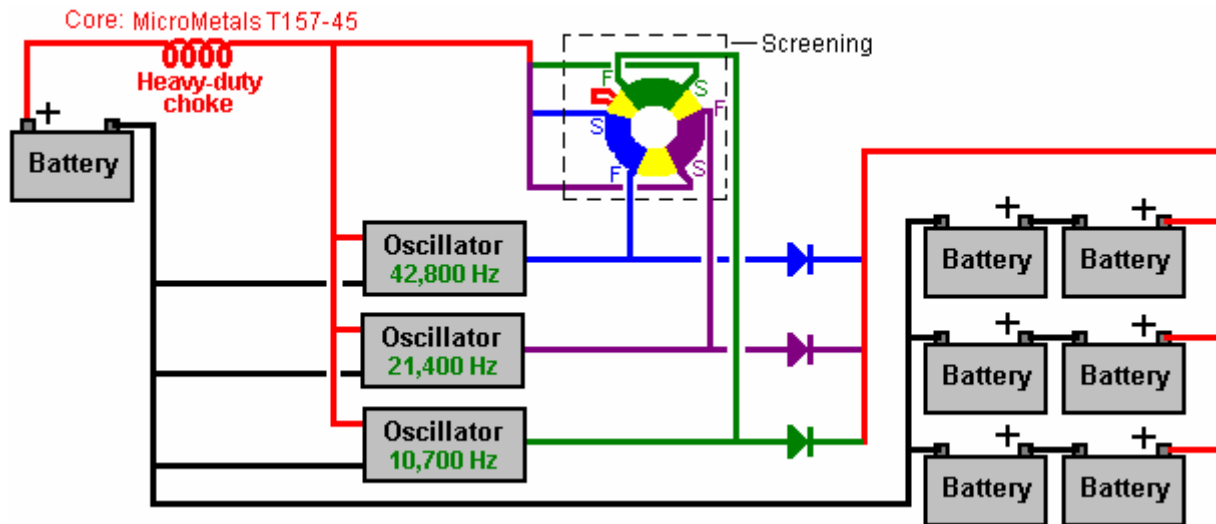

As the output voltage is doubled, the battery bank being charged can be double the voltage of the battery supplying the input power. The choke in the lead from the input battery positive is to direct the power generated to the charging batteries. Each primary winding is driven by its own separate oscillator which has adjustable frequency and adjustable Mark/Space ratio, or "Duty Cycle". The Duty Cycle is set initially to about 25% which means that the input power is turned off for three quarters of the time. The highest frequency oscillator is adjusted to give the largest charging output current. Then, the middle frequency oscillator is adjusted to give the highest charging output. Finally, the lowest frequency oscillator is adjusted to give the highest charging output. When that has been done, the Duty Cycle of each oscillator is lowered as far as possible without lowering the charging rate. An oscilloscope is not needed for any of these adjustments.

It should be noted that what was marked as the "Start" of each primary winding in the diagrams showing how each winding is done, is connected to positive power supply line and the end marked "Finish" is connected to the output of the oscillator. This connection arrangement is very important because connecting them the other way round is likely to give a much lower performance.

The three oscillators are quite independent of each other and are free-running. In other words, they are not synchronised in any way and will produce all sorts of different combinations of composite output waveforms as a result of this arrangement. It must be noted that this is **not** a system which produces a rotating magnetic field as the windings are **not** pulsed sequentially. As already mentioned, the voltage output waveform from each of the oscillators must have very sharp rise and fall times and the output must, of course, be capable of supplying sufficient current to power the primary windings.

I have never seen an explanation of how this system works, and please remember that the circuit shown above is based on my guesswork and does not come from Bob Boyce. However, I will now suggest a possible mechanism for the way that the circuit works, and for it, let us assume that there is only the highest frequency oscillator connected: When there is an output pulse from the oscillator, a powerful current passes through the primary winding to which it is connected. This generates a strong magnetic pulse. But, since the winding is around a high-quality toroidal core, nearly all of the magnetic flux races around the toroid instead of radiating outwards. That magnetic pulse induces an electrical pulse in both of the other two primary windings, and so all three windings provide a current surge to the battery bank being charged. One pulse in, produces three pulses out,

which matches the observed tripling of the input current.

(This suggests that if there were four primary windings that there would be an increased COP result for that arrangement. If that were done, then the fourth oscillator might run at around 85,600 Hz). The short-circuiting of the ends of the secondary winding produces a further increase in the output. I would suggest that this may be due to the fact that the turns ratio of the primary-to-secondary winding, produces a much higher voltage in the secondary winding. If the ends of the secondary winding are connected, then that induced voltage will generate a strong electrical current flowing through the secondary winding. That current will in turn, generate an even greater magnetic pulse, both in the toroid and in the primary windings which are wound around the secondary winding. This enhanced magnetic pulse may account for the enhanced electrical output to the battery bank being charged. Please remember that this not a matter of fact, but just a suggestion which I am putting forward as being a possible explanation of how the circuit is functioning.

Please remember that the toroid has to be able to handle frequencies far higher than the pulsing rate which is applied to it. A high-frequency waveform looks like this:

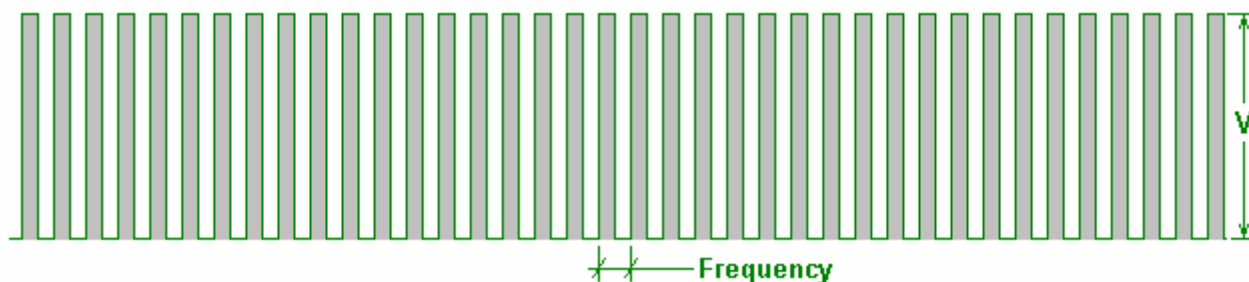

If you apply that frequency to Bob's toroid, then the toroid needs to be able to handle the waveform cleanly, without degrading it in any way. For this sort of application, an iron-dust toroid such as the MicroMetals product is essential. What many people have difficulty in seeing, is that even if the overall frequency of the signal is lower, as shown here:



in order for the rising edge of the waveform to be handled cleanly, the toroid has to be able to handle a very high frequency signal. The toroid doesn't "know" that the leading edge of the waveform is not going to be followed by a whole stream of very short, very fast, high-frequency pulses. So the toroid has to be able to handle high-frequency waveforms in order to deal with the very sharply rising leading edge which is essential for the successful operation of this and many other free-energy devices.

Bob Boyce has experimented with the much more dangerous rotating magnetic fields type of circuitry and he says:

While working as an engineer for a government subcontractor, I became aware of a problem with a switcher power supply, which under certain temperature and load conditions, would go into over unity operation. Sometimes these would fail in a big way and totally destroy the load. There was far more damage than the power source to the power supply was capable of delivering. The power supply used an on-board toroidal coil wound with teflon insulated, silver-plated solid copper wire on Honeywell powdered iron cores. I guess that this was what started my interest in this. When I went into business for myself, I had the time to devote to research and experimentation.

My early radiant energy research and experimentation were with attempting replications of Tesla and Moray devices, as well as many others. I found a copy of Dr. Hans A. Niepers' book "Revolution" ISBN 3-925188-07-X. In that book there is information about many devices related to the conversion of gravity field energy.

My first foray into a 3-phase device was during experimentation with a g-strain energy absorber as theorised by professor Shinichi Seike. Needless to say, the results were not what I expected when I connected a 3-phase air core toroid to the 3-phase outputs of the g-strain energy absorber board.

I had been doing these experiments at home and that was where my lightning strike injury occurred in 1995. That put an end to my 3-phase research for a number of years. When I did start back into it, I soon tired of the expense of burned out electronics and loads. I went back to the lower powered single-phase transformers and stuck with that until I worked out some of the control issues which would allow me to get back into the 3-phase design in a more controlled manner. I wish that I had heard of Steven Mark sooner as that would probably have saved me some time. Like Steven, I learned to have a very healthy respect for this stuff.

The interesting part is that the experiment was not running at the time of the lightning strike, but the strike did enter the room where I had been running an earlier experiment with the 3-phase toroid driven by the g-strain energy absorber board. I am under the impression that the running of the experiment had somehow imprinted an energy pattern upon me which may have attracted the lightning to me. The lightning entered the room, entered my right hand, exited my right ankle and left the room via the telephone line. I was quite understandably shaken up, but I was able to drive myself to St Mary's Hospital (in West Palm Beach, Florida), where I was treated in the emergency room, and released. The pain in my chest afterwards was something which I would not wish upon anyone! All I could really do was to take pain pills until the pain subsided. Considering that I had a well-grounded (by three 20-foot long half-inch diameter copper pipes, one connected to each leg of the base, and a 20-foot long half-inch diameter copper pipe at each guy point) 160-foot radio tower only twenty feet away from that room, the entire house should have been protected under the "cone of protection" provided by that tower. That particular lightning strike defied all common sense of good lightning protection. It was as if it targeted me directly, despite the well-protected location. I have had avalanches occur since then, but I make darned sure that I am very well protected against lightning before running any of these experiments now. I have had the metal building struck but it has not penetrated inside. There are 8-foot long, five-eighths inch diameter copper clad steel ground rods at each corner of the building. I have an 8-foot by 10-foot PVC utility building in which I can run an experiment while I watch on a closed-circuit TV monitor, from the safety of my metal building.

The core does provide stability. I use a low-permeability core in order to avoid saturation from the bias. The lower the frequency, the fewer impulses (kicks) there are per second which results in a lower power density but it also lowers the relativistic effects in the core. So sure, it is a trade-off of control versus power. If the controller were to be fitted totally within the "eye of the storm", that is, in the centre of the toroid space, then the power density could be greatly increased. My main concern would be losing control in a runaway situation with the controller ignoring command signals from the outside due to these relativistic timing changes. Energy induced in even DC control wiring can override those control signals. You would not want to be anywhere near that if it happened.

I do not like to use ferrite or laminated iron cores. With their high permeability, they can only be used at very low frequencies and very low power densities.

One of the features of this power source is that it seems to adapt to the load (within reason, of course). Load impedance is fairly important for getting maximum power output, due in part, to the High-Frequency portion of the energy riding on the DC output. Momentary short-circuiting of the output does result in a plasma-like discharge arc.

From what I can see, my toroid and that of Steven Mark do look to be very similar. The primary differences that I can see are the core material and the number of poles. It sounds and looks like Steven Mark used stranded copper wire and 4 poles, while I use powdered iron and 3 poles in my current device. Otherwise, both seem to build up a swirling electromagnetic vortex during operation.

Over the years, I have used other core materials with varying degrees of success. I started out with laminated iron cores on 2-phase devices in the mid 1980s and then progressed to air-core 3-phase devices in the early 1990s. One of the first units on which I tried 3-phase operation was a Seike "g-strain energy absorber" which I had connected to a hand-wound 3-phase air-core toroidal coil. Talk about uncontrolled operation! But I kept at it, unaware of the dangers. Since I was no longer doing the HHO gas research at that time, I was obsessed with trying to replicate Tesla and Moray research on a shoestring budget. After my lightning strike injury in 1995, I mothballed that line of research until I had the time, energy and funds to continue. I refused to apply this 3-phase design to practical application until the control issue could be solved.

One technique which can be used to improve the power density at low frequencies is to go from 3 primaries to 6 primaries, that is, two phased sets of 3-phase drive coils.

In March 2012 a similar style of circuit design is to roll out the first 200 commercial units from a company in South Africa. The http://pesn.com/2012/02/22/9602042_South_African_Fuel-Free_Generator_Preparing_for_Market/ web site of Stirling Allan covers many of the details of these units. The expected price for a self-powered 5 kilowatt unit is US \$6000 and there are other units of up to 40 kilowatt output. Stirling has visited the company in South Africa and witnessed the device in operation and was due to receive one of these units in March 2012, but

delivery has been delayed due to the batteries stopping operating after three months of use.

Don Smith's High-Power Devices.

Don Smith was a very talented American who has understood all of Tesla's work and has produced literally dozens of practical devices based on his understanding. You will find more specific details in chapter 3, but in broad outline, a twelve-volt battery can be used to generate the pulsing magnetic field needed to nudge the local environment into providing massive amounts of electrical energy. The device described in detail in chapter 3, has an output of around 160 kilowatts, which is far, far more than any individual would need. In other words, it is a device which could easily power your home, and considering that an electric car needs about 65 kilowatts, one could easily power a vehicle, making it into a fuel-less mode of transport. This is not magic, just standard electrical theory being applied correctly for a change.

The key component in many of Don's devices is the humble, commercial power supply used to drive neon sign displays. This module produces some 9,000 volts at a frequency of 35,100 Hz (cycles per second). As Don points out, when you double the pulsing frequency and double the pulsing voltage, the available power goes up by a factor of sixteen times, because the effect of both of these things is squared. You will recall that Bob Boyce is pulsing his toroid very sharply at 42,000 Hz and that high frequency has a major effect on the power produced in his system.

Don then boosts his working voltage further with a step-up transformer called a Tesla Coil. This brings us into an area of massive power. People have the very mistaken idea that a Tesla Coil can only produce voltage and not current. The reality is that if the primary coil is positioned in the centre of the secondary coil, then the voltage and current produced will be roughly the same, and that is a very, very high level of power. One device of Don's looks like this:

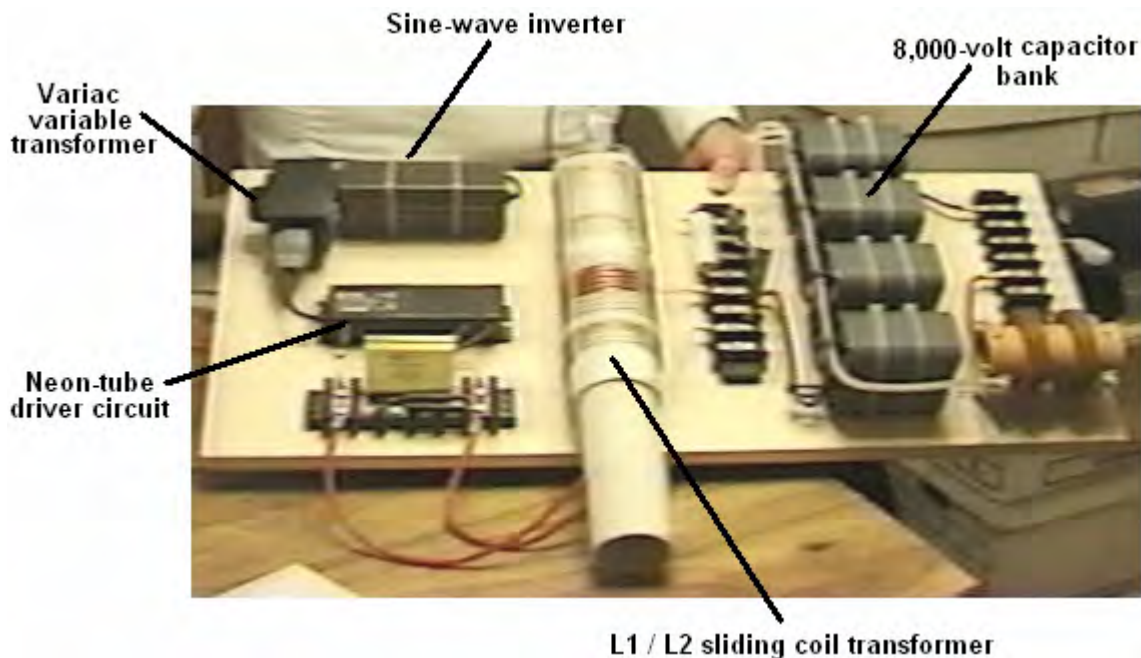

This prototype is actually more complicated than it needs to be. It uses three very high-voltage capacitors which are not necessary if you opt for a slightly different method of construction. However, in this version, the twelve-volt battery (which is not shown), powers a true sine-wave inverter in order to provide the mains voltage and frequency needed by the neon-tube driver circuit. The voltage limitations of the capacitors, in particular, the 8,000-volt output storage capacitors, make the 9,000 volt output of the neon-tube driver too much for safe usage. To deal with this, Don uses a Variac-style variable transformer to lower the voltage supplied to the neon-tube driver circuit, and this lets him limit the output voltage to the 8,000 volts of the output storage capacitors.

A key detail is that the wire length in the turns of the short primary winding of the Tesla Coil is exactly one quarter of the wire length of the turns in the long secondary winding. This makes the coils resonate which is a vital factor in the operation. The final, exact tuning, can be done by sliding the primary coil to a slightly different position. In this prototype, Don chose to do the final fine tuning by attaching a small capacitor across each of the windings. This is not necessary.

In the prototype shown above, Don then uses four diodes to rectify the output to DC to feed the storage capacitors. This results in an 8,000 volt supply which can provide 20 amps of current. That is an output power of

160 kilowatts, and is limited by the output capacitor voltage rating.

Don points out that it is not necessary to do it that way and instead, a step-down transformer can be used to lower the output voltage and boost the available current. If this is done, then the voltage limitations disappear (provided that you are using very high-voltage cables) and so no Variac is needed and no high-voltage capacitors are needed either.

There are two options. Either you can aim for a mains-voltage, mains-frequency, AC output, or you can produce a DC output and use an off-the-shelf inverter to run any mains equipment powered by the device. With the first option, Don connects a single resistor across the primary of the step-down transformer and that drags the frequency down to the wanted level, provided that the resistor has the right value:

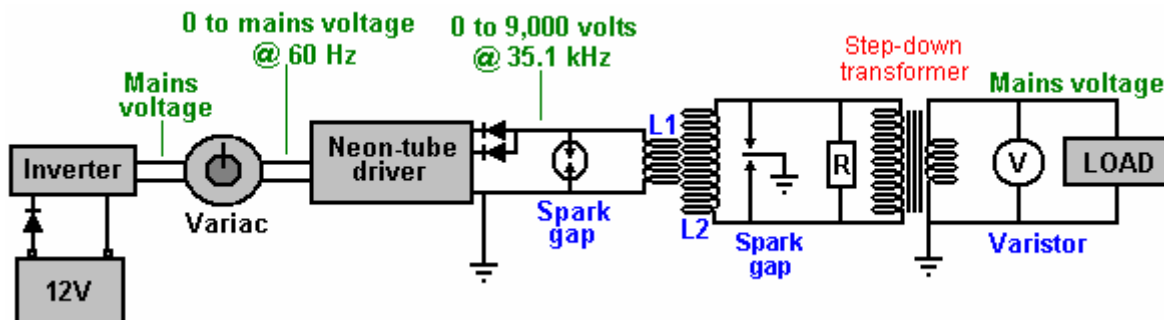

The alternative method which aims for a DC output does not need to alter the frequency:

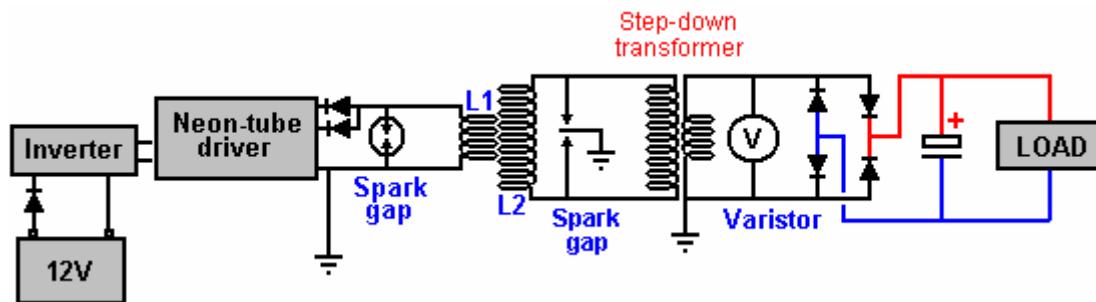

In both of these cases, the twelve volt driving battery can be charged continuously by part of the output power, and there are various ways of doing that. However, care needs to be taken that the battery is not overcharged as the input power is very low.

You will notice the similarity between Bob Boyce's toroid system and Don Smith's Tesla Coil system. In each case, a very carefully wound circular winding is pulsed at high frequency, and in each case, substantial amounts of excess electrical power becomes available, flowing in from the surrounding environment, courtesy of the pulsating magnetic field.

Tariel Kapanadze's Self-Powered Generators.

Tariel Kapanadze produced a similar style of device which is self-powered and produces a mains electricity output. He has demonstrated this for a TV documentary. Further details available are in chapter 3.

The Insights of Vladimir Utkin

Vladimir has issued a paper in which he describes some of the very important work done by himself and members of a Russian forum. He has major insights into the work of Tesla, Don Smith and others. With his kind permission, his paper is freely shared here <http://www.free-energy-info.tuks.nl/VladimirUtkin.pdf>.

Walter Ford's High-powered Crystal Set

In the 1961 edition of the Electronics Experimenter's Handbook, there is an interesting circuit from Walter B. Ford for a high-power crystal set capable of powering a 2.5-inch loudspeaker:

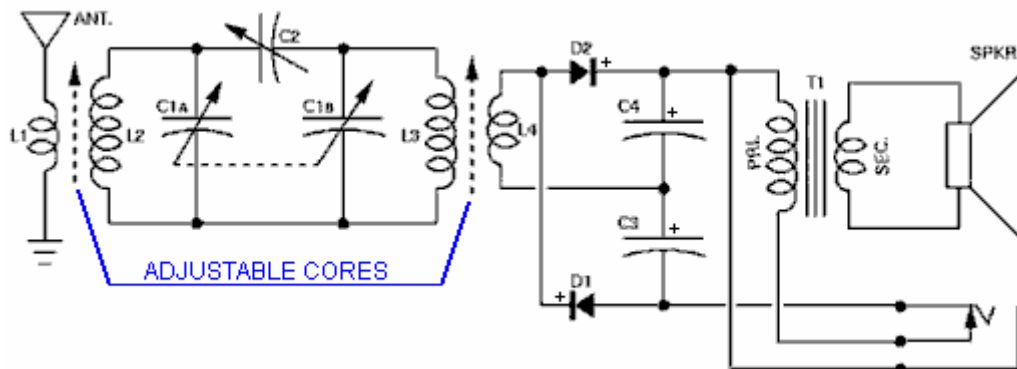

PARTS LIST

- C1a/C1b-- 2-gang, 365-uuf. variable capacitor (Lafayette MS-142 or equivalent)
- C2-- 180-uuf. compression-type trimmer capacitor
- C3, C4-- .005-uf. fixed capacitor
- D1, D2-- 1N34A diode
- J1-- Closed-circuit phone jack
- L1, L4-- 22 turns of No. 24 cotton-covered wire (see text)
- L2, L3-- Ferrite antenna coil (Miller 6300 or equivalent)
- R1-- 47,000 ohm, 1/2 watt resistor (*optional, see text)
- T1-- Replacement-type output transformer; 3000- to 10,000-ohm primary; 4-ohm secondary
- Spkr.-- 2 1/2" speaker, 4-ohm voice coil (Lafayette SK-65 or equivalent)
- Misc.-- Hardware, wood, sheet aluminum, Fahnestock clips, etc.

He says: Here's a pint-sized crystal radio with enough power to drive a 2 1/2" speaker. This little unit's selectivity is far better than you would expect to find in a crystal receiver and volume is equal to that obtained with sets using a transistor. No external power source is required.

The unusual selectivity of this radio is due to its special double-tuned circuit. A pair of diodes connected as a voltage-doubler provides the extra power to operate the small speaker. An output jack is provided for headphone listening and for connecting the set to an amplifier.

Construction: The model was built on a 2.5" x 4.5" wooden chassis with a 3.5" x 4.5" metal front panel. However, size is not critical, and other materials can be substituted if desired.

Two standard ferrite loopsticks, L2 and L3, are used. Both must be modified by the addition of a second winding. L1 and L4, respectively. Each of the added windings consists of 22 turns of No. 24 cotton-covered wire wound on a small cardboard tube as shown in the picture. (Actually, any wire size from No. 22 to No. 28 with cotton or enamel insulation will do the job).

The diameter of the cardboard tube should be slightly larger than L2 and L3 so that L1 and L4 will slip over L2 and L3 easily.

Resistor R1 is used only for feeding the set into an amplifier; it should be omitted for both earphone and loudspeaker operation. Trimmer capacitor C2 should be soldered across the stator terminals of two-gang variable capacitor C1a/C1b as shown. The speaker and output transformer can be mounted wherever convenient.

If a metal chassis is used, then be sure to insulate the aerial and earth connection sockets from the chassis. When all of the parts have been mounted on the chassis, wire them together following the schematic and pictorial diagrams. Be sure that diodes D1 and D2 and capacitors C3 and C4 are connected correctly, paying attention to their polarity.

While this is interesting, what appears to be a key factor is contained in the drawings, where he states that the only important thing is that it is essential for the two sets of coils to be mounted perpendicular to each other:

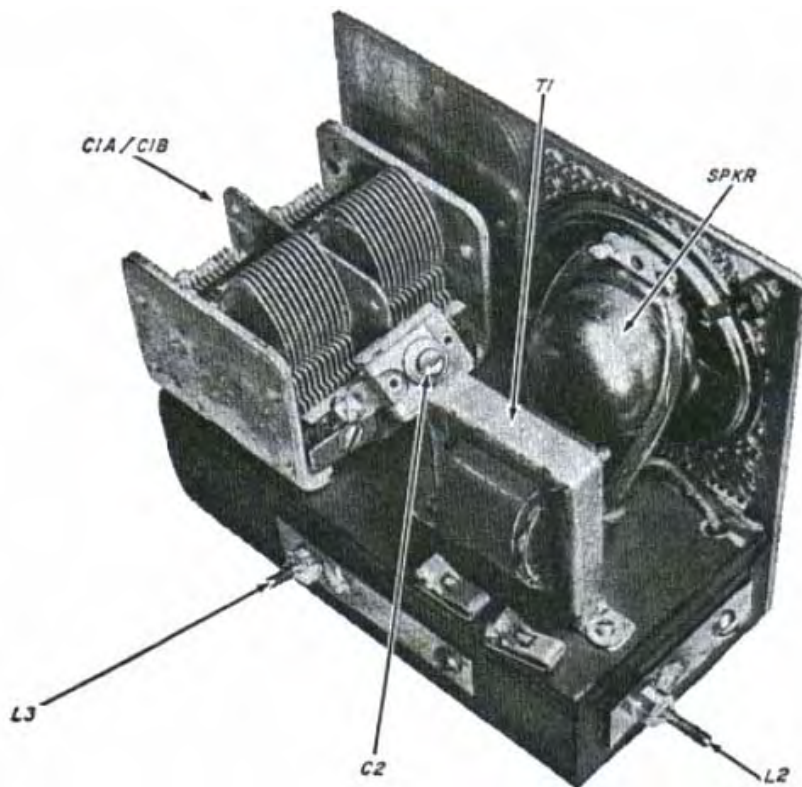
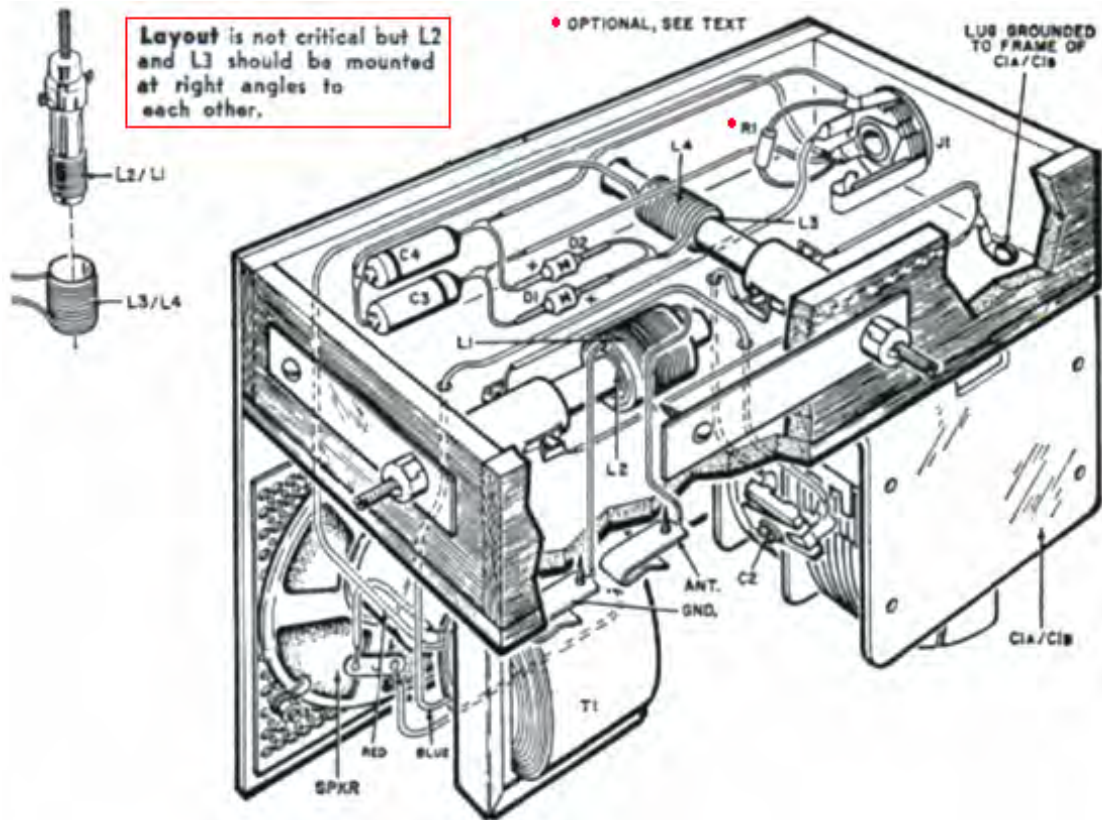

Alignment and Operation. To align the receiver, connect it to an antenna and ground. The optimum length of the antenna varies with location, but 50 feet will usually be suitable in areas which receive several broadcast stations. Next, plug a high-impedance earphone into jack J1. Tune a station near the high frequency end of the broadcast band – say, 1500 kHz – and adjust the trimmer capacitors on variable capacitor C1a/C1b to get the loudest signal.

Trimmer capacitor C2 should then be adjusted for the best selectivity and volume over the entire broadcast band. Finally, Coils L1 and L4 can be moved to their optimum positions by sliding them backwards and forwards over coils L2 and L3. If a nearby station interferes with the reception of a weaker station, tune the slug of L2 to get minimum interference. For loudspeaker operation, simply unplug the earphone. Strong local stations should be received at fair volume.

How It Works: The receiver employs a double-tuned circuit feeding a crystal diode voltage-doubler/detector which drives a small loudspeaker. Radio frequency signals picked up by the antenna system are induced into coil L2 from coil L1. The desired signal is selected by the tuned circuit C1a/L2 and coupled through capacitor C2 to a second tuned circuit C1b/L3, which improves the selectivity by narrowing the radio frequency bandpass. The twice-tuned signal is then induced into coil L4 from coil L3.

The positive half of the radio frequency signal appearing across L4, passes through the 1N34A germanium diode D2 to charge capacitor C4. The negative half of the signal passes through diode D1 to charge capacitor C3. The polarity of the charges on C3 and C4 are such that the effective voltage is doubled. This voltage appears across the primary of output transformer T1 which converts the high-impedance signal to a low-impedance output suited to the loudspeaker.

While this looks like a very good design for a crystal set, the fact that it is insisted that the coil pairs **must** be mounted at right angles to each other raises an interesting parallel with the above work of Vladimir Utkin where he states that if the high-frequency excitation field is at right angles to the output coil, then there will be a free-energy inflow into the circuit from the local environment. Perhaps this crystal set design gains extra power to drive it's loudspeaker from an inflow of environmental energy.

Lawrence Tseung's Self-Powered "FLEET" Generator.

The "FLEET" ("Forever Lead-out Existing Energy Transformer") device is a self-powered electrical generator which has no moving parts and which can be constructed cheaply. It has been developed by a Hong Kong based team of people: Mr Lawrence Tseung, Dr. Raymond Ting, Miss Forever Yuen, Mr Miller Tong and Mr Chung Yi Ching. It is the result of some years of thought, research and testing and it has now reached an advanced stage of testing and demonstration and is nearly ready for commercial production.

Mr Tseung has applied his "Lead-out" theory to the category of low-power circuits known as the "Joule Thief" circuits. These circuits originated with an article by Mr Z. Kaparnik, in the "Ingenuity Unlimited" section of the November 1999 edition of the "Everyday Practical Electronics" magazine.

The initial circuit allowed the very last energy to be drawn from any ordinary dry-cell battery, and used to light a white Light-Emitting Diode ("LED") for use as a small torch. It allows a battery which is considered to be fully discharged, to drive the circuit until the battery voltage drops right down to 0.35 volts. The initial circuit uses a bi-filar coil wound on a ferrite ring or "toroid". Bi-filar means that the coil is wound with two separate strands of wire side by side, so that each adjacent turn is part of the other coil. A coil of that type has unusual magnetic properties. The Joule Thief circuit is like this:

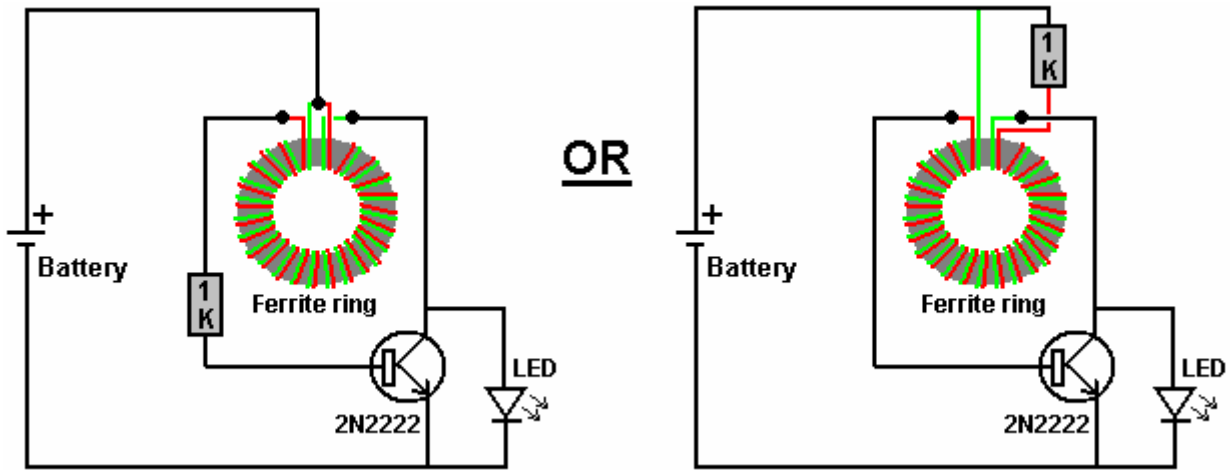

It is important to notice how the coil is wound and how it is connected. It is called a "toroid" because it is wound on a ring. The ring is made of ferrite because that material can operate at high frequencies and the circuit switches On and Off about 50,000 times per second ("50 kHz"). Notice that while the wires are wound side by side, the start of the red wire is connected to the end of the green wire. It is that connection which makes it a "bi-filar" coil instead of just a two-strand coil.

This "Joule Thief" circuit was then adapted by Bill Sherman and used to charge a second battery as well as lighting the Light-Emitting Diode. This was achieved by adding just one more component - a diode. The diode used was a 1N4005 type because that was to hand at the time, but Bill suggests that the circuit would work better with a very fast-acting Schottky-type diode, perhaps a 1N5819G type.

The circuit produced by Bill is:

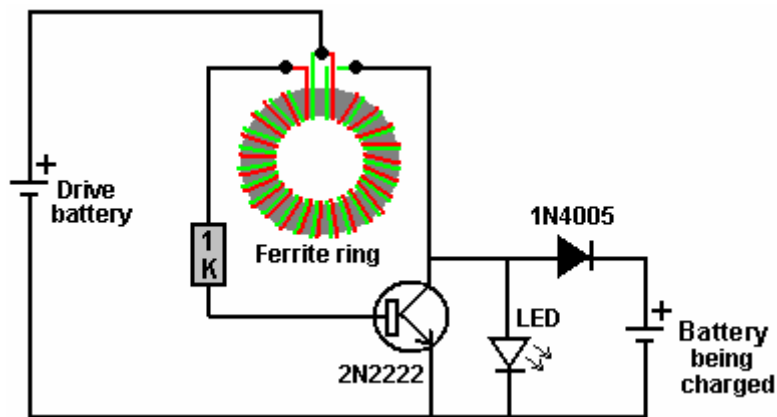

When driven by a 1.5 single cell battery, this circuit produces about 50 volts with no load and can supply 9.3 milliamps of current when the output is short-circuited. This means that you could charge a 6-volt battery using a 1.5 volt battery.

"Gadgetmall" of the www.overunity.com Joule Thief forum has taken the circuit further and found a very interesting situation. He has modified the circuit and used a "batt-cap" which is a very high capacity, very low-loss capacitor. This is his circuit:

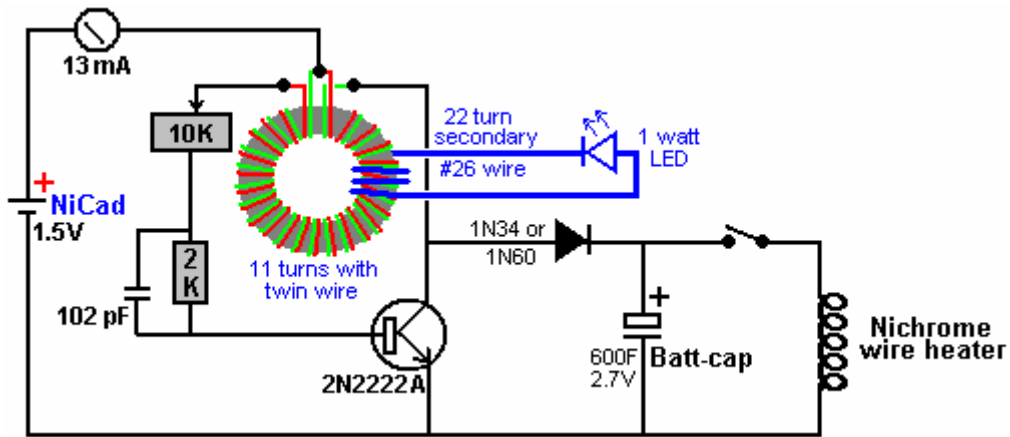

He has added an additional winding to his one-inch (25 mm) diameter ferrite toroid, and he uses that to power a 1 watt LED. Why he has done this is not immediately clear to me, except possibly, that it shows when the circuit is operating. He runs the circuit driven by a small rechargeable battery, which feeds 13 milliamps into the circuit, for a period of fourteen hours. At the end of that time, the batt-cap has gathered enough energy to fully recharge the driving battery in a minute or two, and then power a heater winding of nichrome wire (as used in mains-powered radiant heaters) for four and a half minutes. Alternatively, that amount of extra power could boil a kettle of water. The really interesting thing about this is that the driving battery gets recharged every time and so the circuit is self-sustaining although it is not a powerful circuit.

Mr Tseung has taken the Joule Thief circuit and modified it to become a circuit with a very serious output, moving it into a completely different category.

As a first step towards what the team calls their "Fleet" device, the toroid has been enlarged to a much greater diameter. The coil is now wound on a section of plastic pipe, 170 mm (6.5 inches) in diameter and 45 mm (1.75 inch) deep:



This section of pipe is "bi-filar" wound with two wires side by side as already described for the Joule Thief construction. As before, the start of one wire is connected to the end of the other wire. Then, the winding is given a layer of electrical tape to hold it in place and to provide an easy working surface for a second winding.

The wire used for the winding is the widely available red and black pair of wires, sometimes called "figure of eight" because the cut end of the wires looks like the numeral 8. The wire should be able to carry 2.5 amps. It must be side-by-side wire and **not** one of the twisted varieties. It looks like this:



The second winding is made in the same way but the connections are slightly different. As before, the end of the first wire is connected to the start of the second wire, but that connection is then insulated and not used in the following circuitry. This just connects the two windings one after the other, known technically as being connected "in series" and is the equivalent of making the winding with just a single strand of wire. The completed coil may look like this:

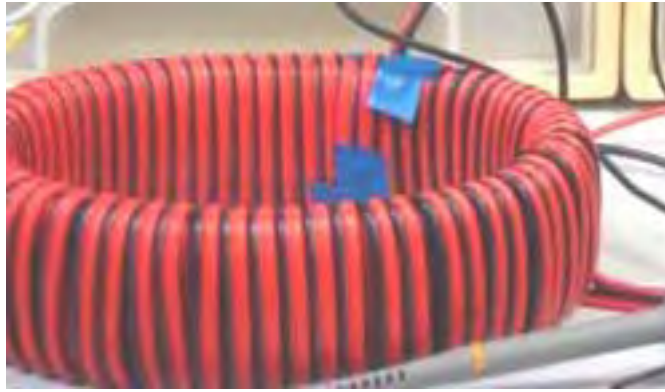

This particular design is still in its early stages and so many different coils sizes and constructions are being tested:



The arrangement is for the inner winding of the toroid to be oscillated by the Joule Thief circuit already described. This causes a pulsating magnetic field to envelope the outer winding of the toroid, producing an electrical output which is capable of doing useful work. The really important thing about this arrangement, is the fact that the amount of power coming out of the circuit is very much greater than the amount of power needed to make the circuit operate. The additional power is led out of the local environment and drawn into the circuit, becoming available to do useful work.

The overall circuit then looks like this:

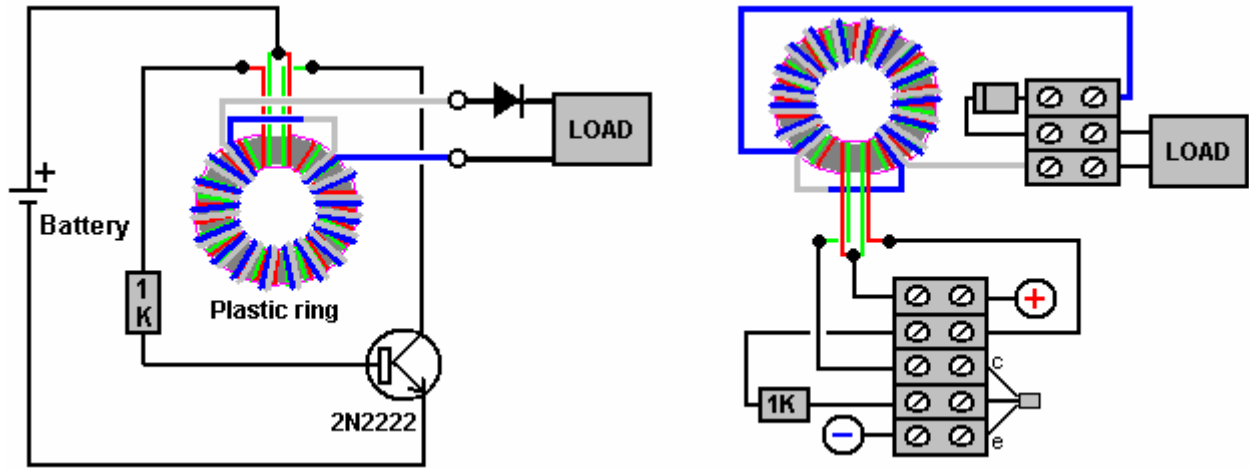

While the outer winding is shown here with thicker wire of a different colour, this is only to make the arrangement easier to understand. In reality, the outer winding is with exactly the same wire as the inner winding, and it will normally go all the way around the toroid. The total amount of wire needed to make the windings is about 70 metres and so it is normal to buy a full 100 metre reel of the twin-core wire, which allows both windings to be made and leaves spare wire for other things.

For those of you who are **very** technically minded, the output waveform looks like this:

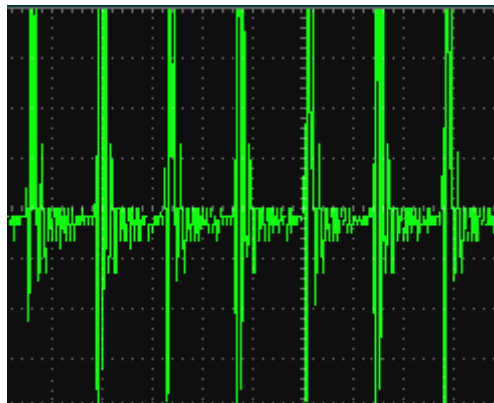

and the voltage pulses in this output are occurring about 290,000 times per second.

What has worked better for me is using a bridge of four diodes rather than a single diode:

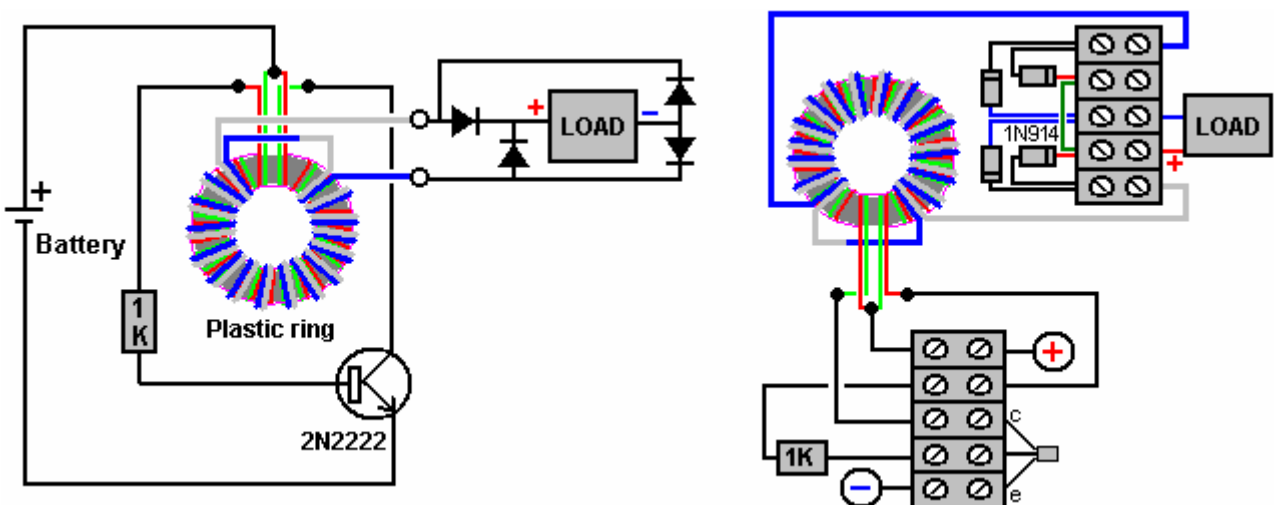

I have used this circuit, driven by a 1.5 volt battery, to charge 12-volt batteries, but the best results are in the five to six volt range. I have used this circuit to confirm COP>1 by charging one small 12V lead-acid battery with an identical battery, swapping the batteries over and repeating the process several times. The result was that both batteries gained genuine, usable power. I suspect that the effect would have been much greater if I had charged two or more batteries in parallel. The toroid was an 8-inch diameter, 10 mm by 12 mm offcut from a plastic pipe

which happened to be to hand and the wire used was plastic covered 6-amp equipment wire, again, because it was to hand at the time. Winding the toroid and setting up the circuit was done in a single evening.

Overall, this is a very simple, cheap and easily constructed COP>10 device which has the potential of providing large amounts of free, useable, electrical power. With further development, it may well be possible to produce a version which could deliver the power needed by a whole household. It is also likely that these devices will become available for purchase a quite a low cost. All in all, this is a very important device and full credit must go to the development team who have carried the research to this point and who are continuing to refine the design to produce more and more power.

Advanced versions of the Joule Thief Circuit.

A contributor who prefers to go by his ID of "Ace_Propulsion" shows here a series of clever, innovative variations on the well-known Joule Thief circuit.

What is a Joule thief? A Joule Thief circuit is a minimalist self-oscillating voltage boosting circuit which is small, low-cost and easy-to-build. It is normally used for driving light loads. It can use nearly all of the energy in a single-cell battery, even those which are already far below the voltage level where other circuits consider the battery to be 'fully discharged' (or "dead").

Notice the description "voltage booster". This means that the output voltage is increased at the expense of a higher input current draw. Conventional science says that a Joule Thief circuit can never ever achieve COP>1. A conventional Joule Thief circuit as shown below, will always have an energy loss between the Collector and Emitter of the transistor.

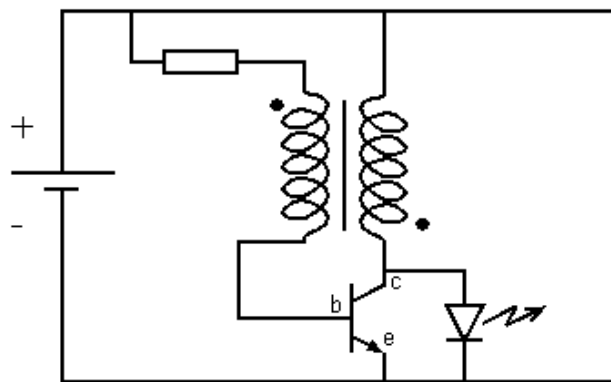

With proper modifications this circuit can acquire energy from the environment to power the output. This is quite simple to achieve. First, before we start discussing circuits, I'm going to tell you the weird stuff about LEDs:

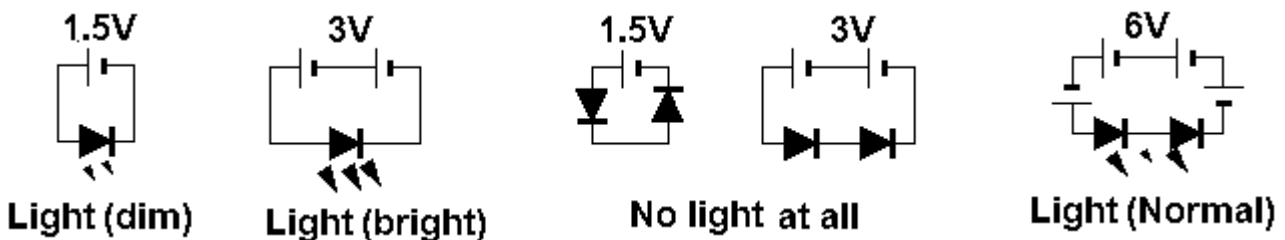

Notice that you can illuminate an LED with just 1.5 Volts and get a brighter light by using 3 Volts. But if you connect two LEDs in series then that 3 Volts is too low to light them and so there is no light at all and zero current draw. Well, the weird stuff is that you can power ONE LED with 1.5V and can't power TWO LEDs in series with 3volts?!? And, while resistors control the brightness of the light they do not change the voltage required in any way. Now that's it! I used this on a Joule Thief and when I did, I got COP>1 using this circuit:

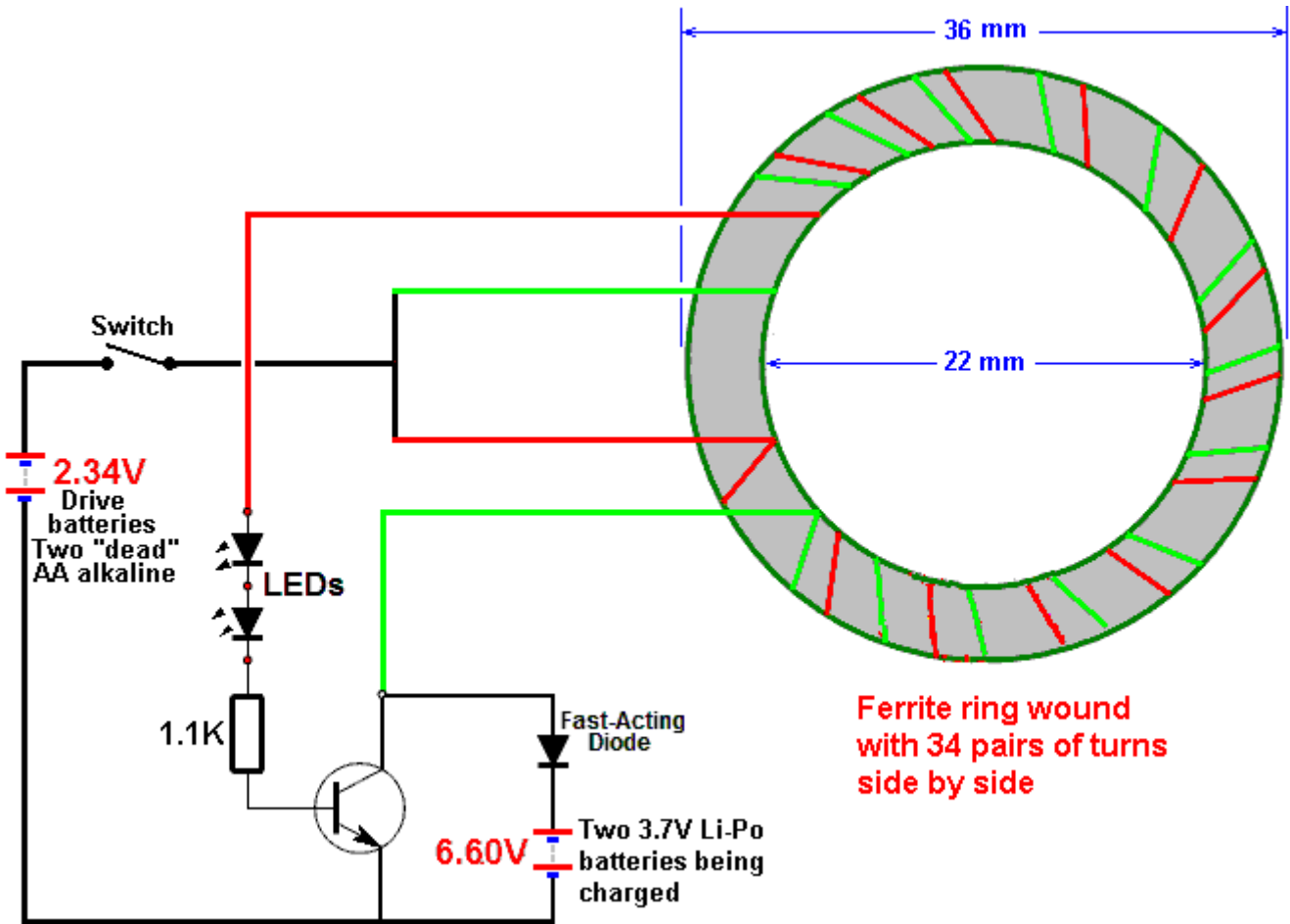

This circuit has an input current of 12.5 milliamps at 2.35 volts (which is 30 milliwatts) and an output current of 8 milliamps at 6.60 volts (which is 52.8 milliwatts) and that is $COP=1.8$ or 80% greater output power than the input power. The ferrite toroid is wound using 0.4 mm diameter enamelled copper wire (#26 AWG) and while the turns are shown slanted in the diagram, the actual direction of the turns is radial, and anyway, the direction of the turns has no effect on circuit performance. It is expected that the diameter of the ferrite ring is not at all critical but only one diameter was available for testing. The fast-acting diode could be an FP607, UF5408 or similar, and it is also possible to use a transistor with the Base and Emitter connected together, instead of a high-speed diode. The LEDs used are 8 mm diameter types.

In this circuit it was found that the input voltage is important. The best input voltage is between 2.2 volts and 2.5 volts, so two Ni-Cad or two Ni-Mh batteries are about the optimum input as higher voltages just cause higher input currents without any improvement in the output power.

The key to free energy from this circuit is to use at least two LEDs connected in series. Place them in the current flow to the base of the transistor and the current fluctuations caused by their 'weird stuff' will boost the energy coming from the output.

one very important point is that there must be at least two LEDs and the circuit must **not** self-start, because if it does, then the input voltage is too high and the circuit will operate at $COP < 1$. Because of this, you need to start the circuit operating by hand, and another very important point is that the output voltage should at least twice as much as the input voltage.

Features of this technique:

- $COP > 1$ can be achieved and then with proper modification the circuit can become self-powered.
- You can extract energy from "dead" batteries and supplement it with additional energy drawn from the environment.
- Go to work and leave the circuit charging batteries at home while you are working.
- Interestingly, high-frequency sound is emitted by the circuit, and that sound tends to keep mosquitoes away!

Fine-tuning the circuit:

There are 5 parameters involved in the operation of this circuit:

1. Input voltage,
2. Output voltage, The coil winding,
3. The diameter of the toroid,
4. The number of LEDs, and
5. The resistor which feeds current to the base of the transistor.

The first step in assembling the circuit is to check the LEDs which you are going to use. These LEDs are going to be connected in series, so start with two and connect them across the battery. If the LEDs light up, then add an extra LED until the chain of LEDs do not light when connected across the battery. Doing this, will raise the COP of the circuit over 1 as the output power will then exceed the input power.

When setting up the toroid assembly, remember that winding more turns on the toroid will make a coil which has higher impedance which will increase the COP value, but too many turns may result in lower current which means a slower rate of charging from the output. The output voltage should **always** be more than twice the input voltage (for example: Input 2.35V Output 6.60V).

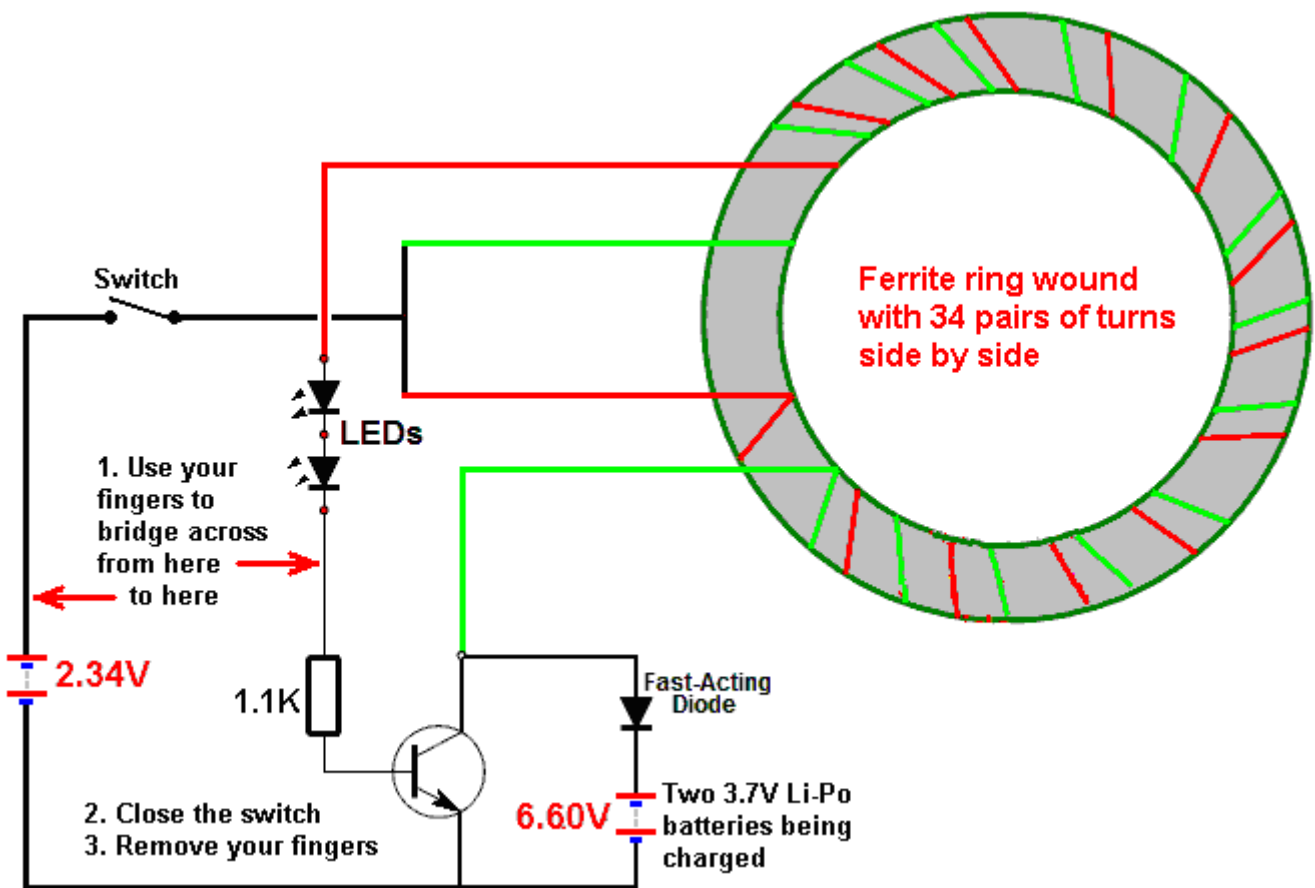

When the circuit has been built as shown above, if it starts running when the switch is closed, then the input voltage is too high, so keep adding an additional LED until the circuit will no longer self-start. Then, use your fingers to start it running by using your body resistance to bypass the LED chain very briefly to get the circuit oscillating. This is a low voltage section of the circuit and so there is no danger at all of getting a shock by doing this. An alternative would be to put a resistor in place instead of your fingers and use a press-to-make switch to trigger the circuit.

A further refinement is to add even more LEDs until the point is reached where the circuit will not start, even if you use your fingers to try to get it operating. When that point is reached, remove one of the LEDs and get the circuit running. Compare the input and output power levels, and then remove one more LED and repeat those power measurements. Keep doing that while you still have more than two LEDs until you determine what is the most effective number of LEDs in your circuit, that is, you find the best COP performance that your circuit can achieve.

In this circuit the LEDs are there to cause base current fluctuations as a mechanism to get COP>1 performance, and so, they are not there for lighting. You may increase the resistor value and so, lower the amount of input current used, but doing that results in lower output power. In my circuit, I used a 1100 ohm resistor.

Further Experiments:

This section is about some experiments which I have done to see if I can improve the performance of the Joule Thief. Obviously, I have not tried every possible arrangement and so I invite you (the reader) to do further experiments as the Joule Thief is clearly a very good circuit with which to experiment.

Charging at just 8 milliamps is too low a rate for a 1000 Milliamp-Hour 7.4 Volt Li-Po battery pack, and so, it is necessary to increase the rate of charge. This can be done by using two or more of these circuits connected in parallel as shown here:

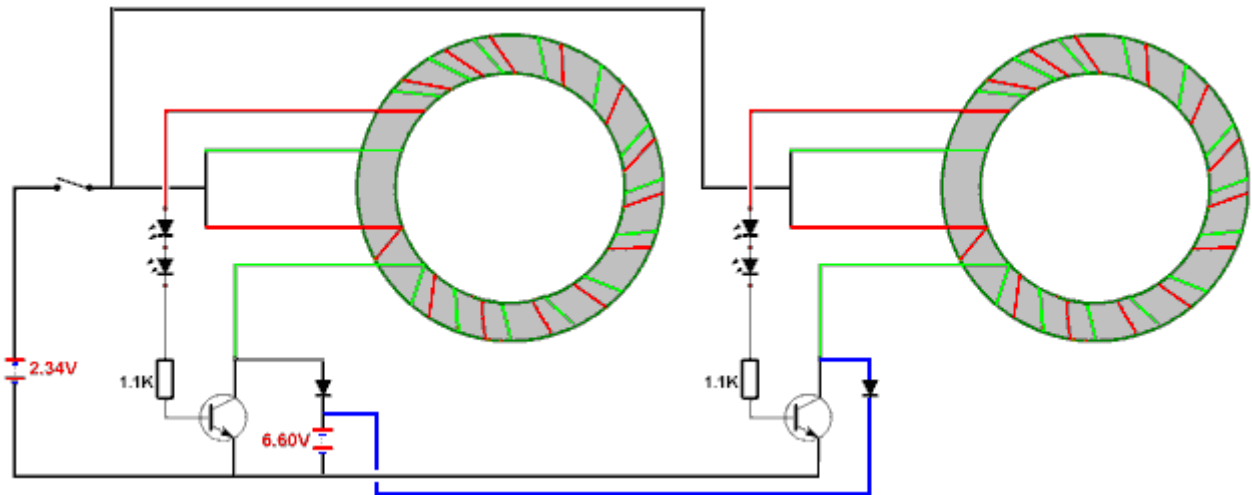

Batteries which are almost fully discharged, have a higher internal resistance than a new battery, and so the higher the current drawn by the circuit the lower the efficiency of the circuit will be. As a result of this, the effective input voltage used by this circuit is actually lower than the 2.34 volts shown in the circuit diagram.

So perhaps it should be arranged like this:

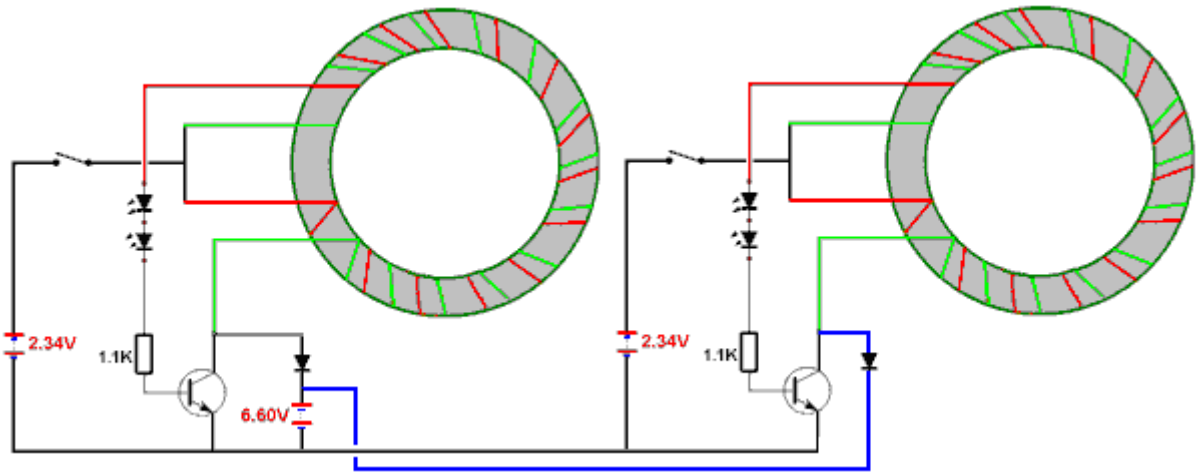

Remember that the output voltage should always be more than twice the input voltage. So if you want to charge Ni-Cad batteries which have a lower voltage, then you should use a step-down transformer as shown here:

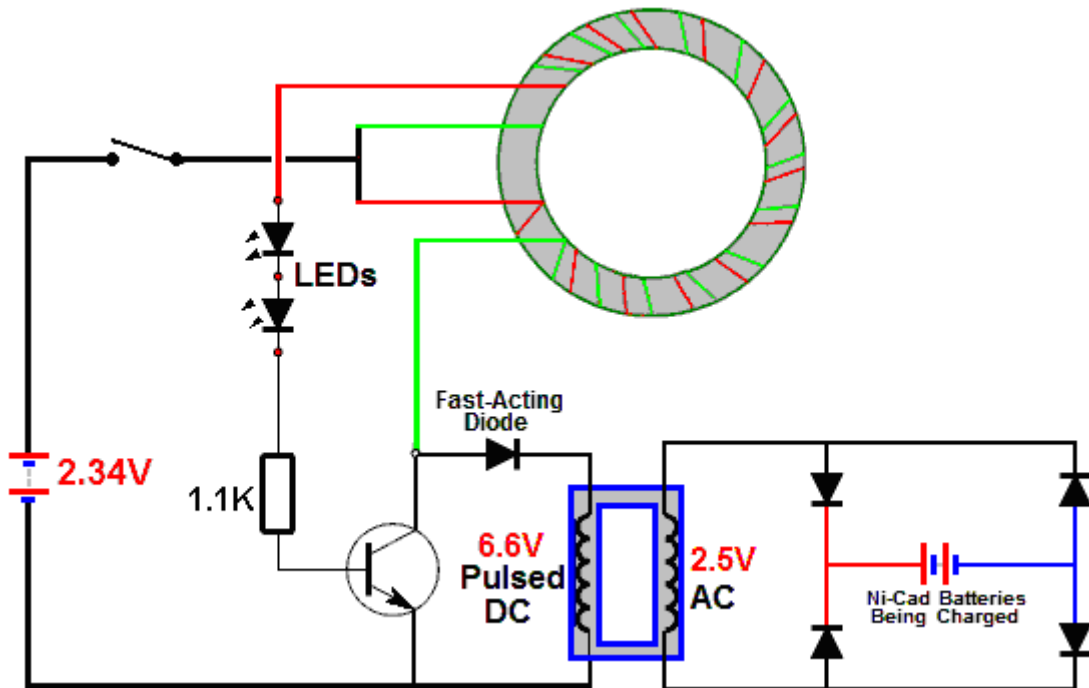

With the appropriate modifications it can become self-powered and self-charging as shown here:

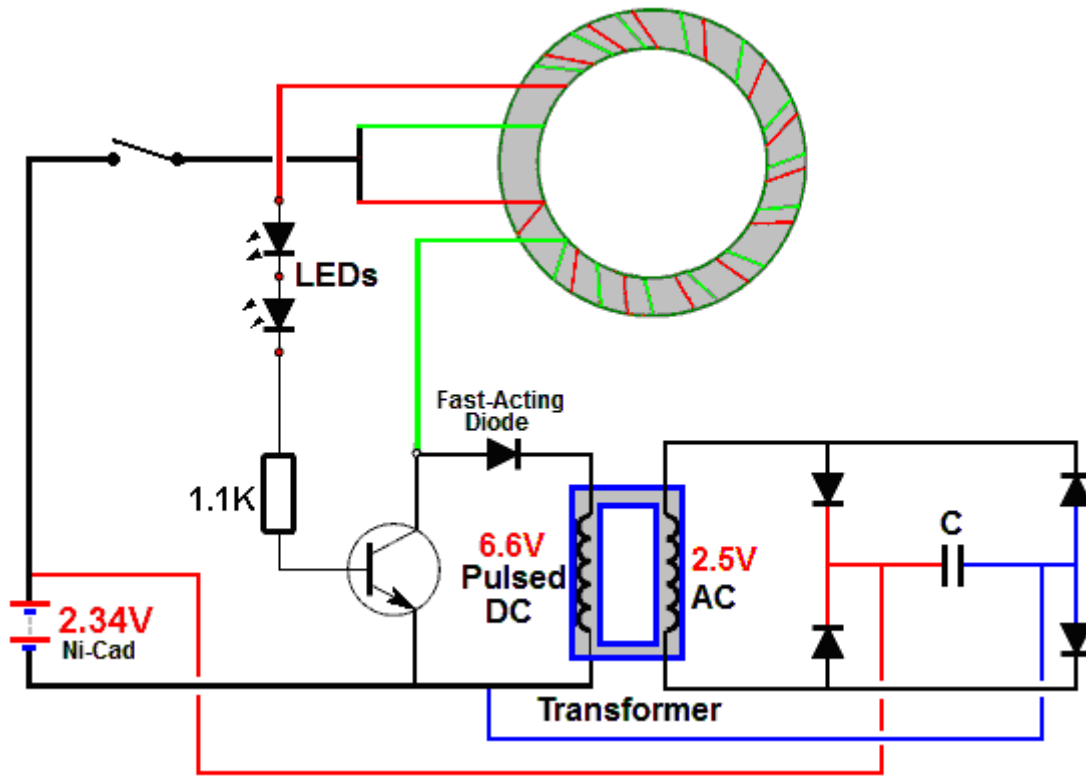

The performance of this circuit can be boosted further by using an asymmetrical transformer such as Lawrence Tseung's Magnetic Frame or Thane Heins' transformer as shown here:

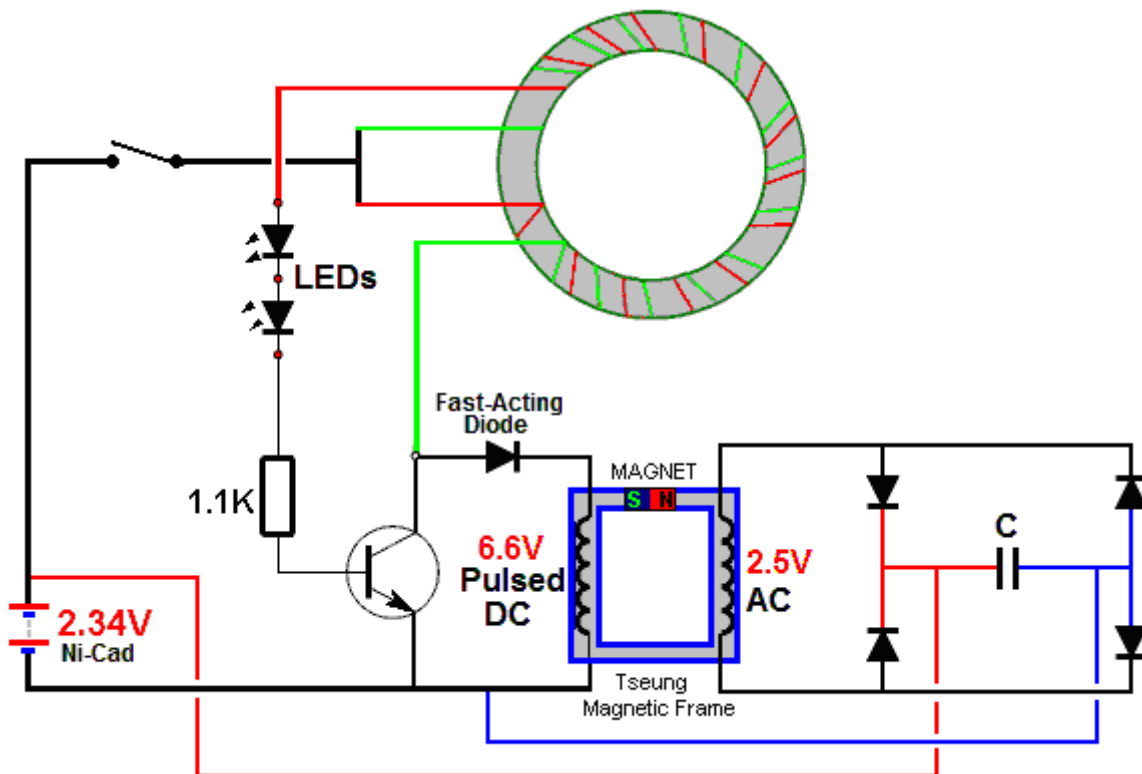

Perpetual Lighting circuit:

Higher voltage results in lower LED resistance and so will decrease the efficiency of the circuit through negative feedback and so the circuit can become stabilised as shown here:

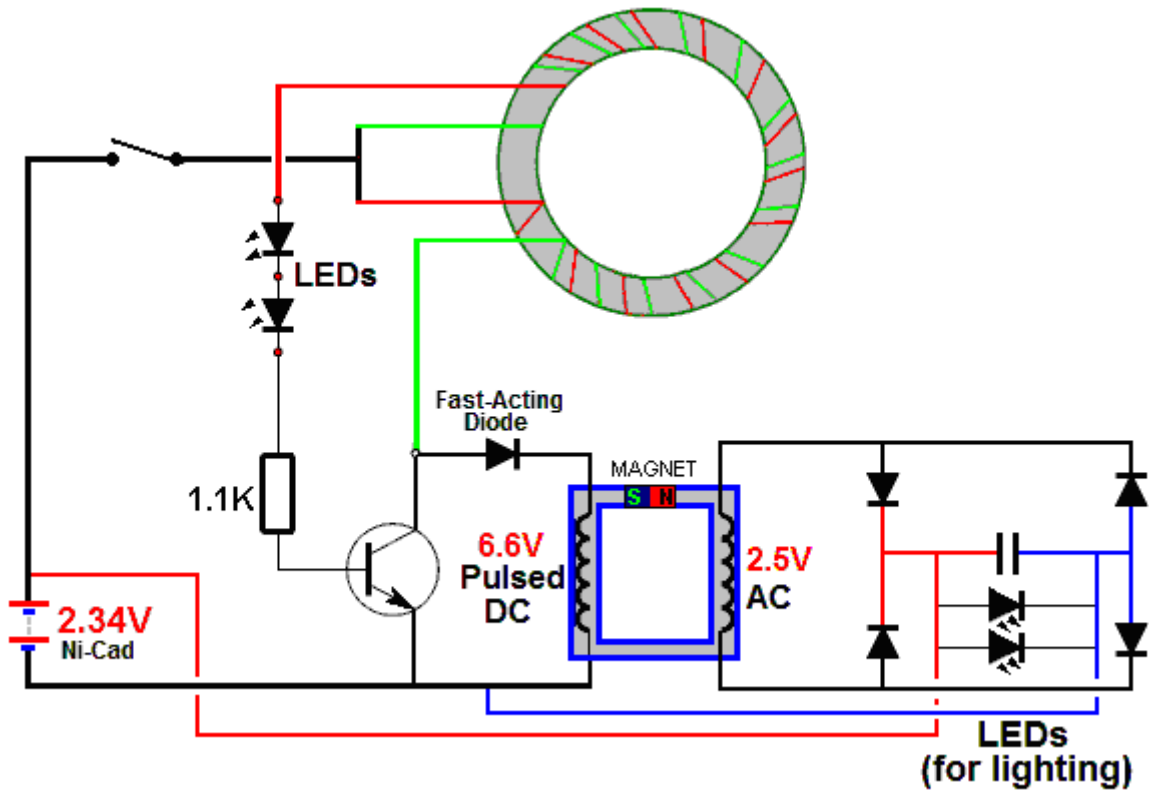

Also, check out the high-power Joule Thief circuits and products at <http://www.madscientisthut.com> giving 1-watt of lighting which is over 100 lumens of light.

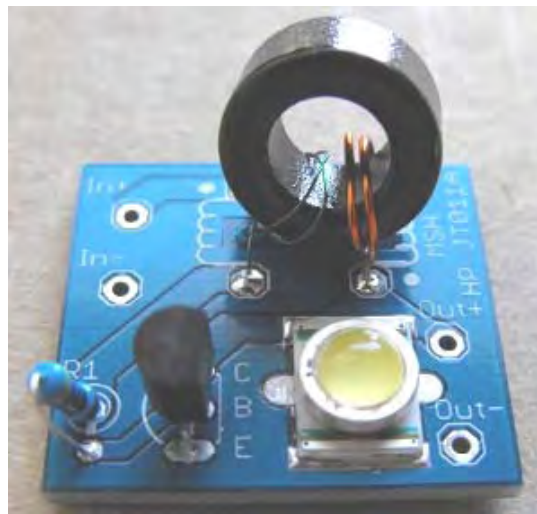

A Suggestion

This is an arrangement of readily available, cheap parts for operating a useful light. Probably the most efficient circuit for this task is the 'Joule Thief' circuit and the light bulb usually chosen for this circuit is the compact fluorescent lightbulb ("CFL") which is widely available around the world and although there are many variations, looks something like this:



The arrow is pointing to a join in the construction where the bulb section joins the lower section which houses circuitry and the mains connector which can be one of many different types. However, that type of bulb has mains circuitry built into it which means that in order to get the higher efficiency which we would like, each bulb needs to be physically modified which is far from ideal. The circuitry inside a bulb of this type, converts the alternating current of the mains into Direct Current and then uses that direct current to supply an oscillator circuit which generates high-frequency pulses which power the bulb. Unfortunately, that circuitry gets in the way of low-power operation and so needs to be removed. People who have done this, say that the bottom can be popped off just by inserting a screwdriver into the crack and twisting the screwdriver to force the two pieces apart. If you try that, then let me wish you luck as it has never worked for me, even when applying enough force to permanently damage the material on both sides of the crack. Instead, I do it by cutting the plastic base 8 mm below the arrow line resulting in this:



The 8 mm clearance is because the glass tubes project down below the join and we need the remaining section of the plastic housing to support the bulb when we mount it on our circuit box. The cut should be made when holding the base section as the glass tubes are very fragile and easily damaged. If available, a Dremel or similar tool which has a small cutting disc very well suited to making this cut. The cut should be just deep enough to go through the plastic wall but not further than that. There is a tiny circuit board contained in the lower part, generally, with some very nice components which can be used for other circuits. The cut-down light bulb can be mounted on the circuit box using a strong adhesive, or a hole can be drilled very carefully in the centre, between the tubes (holding the base and not the tubes when doing this) and the base can then be bolted to the component box.

The glass tubes are U-shaped and there are two inter-tube horizontal connecting tubes in order to make all of the U-tubes function as one long zig-zag discharge path and get all of the tubes lit up at the same time. The two tubes which do not have this horizontal interconnecting tube, have two wires coming out of the bottom of them, and used to connect the circuit to the tubes. These four wires need to be cut, leaving them as long as possible, then each pair has the insulating enamel scraped off them and then soldered to a length of wire which will be used to connect to the new circuit, or alternatively, direct to the board if very small 'fiddly' work is no problem.

This adaption makes this low-cost method unsuitable for applications where an off-the-shelf bulb is needed so that replacements can be made without the need for any technically skilled person to be available. What we need therefore, is a bulb which does not have the mains circuitry (called "ballast") built into it, and the earlier 'PLD' bulbs are in that category. Unfortunately, they are more expensive and not so widely available. They look like this:



These have the enormous advantage of not requiring any work on the bulb in order to operate immediately with our circuit. We can build a suitable circuit from scratch, but it is very popular with home constructors making a one-off experiment to use the very cheap circuit found in Fuji's "Quick Snap" disposable camera which is very widely available. It looks like this:



There are various ways of adapting the circuit board found inside the camera, and thanks is due to 'Gadgetmall' of the <http://www.overunity.com/10723/fuji-joule-thief-full-instructions-video-and-pics/new/#new> forum for sharing his method of adaption and expertise with these circuits, which has allowed him to run a fluorescent light for 38 hours powered by just one AA size 1.5 volt battery

Disclaimer: This document must not be considered to be a recommendation for you to actually attempt to undertake any of the following modifications, and should you decide to do so, then any loss, damage or injury are wholly your responsibility and not that of anyone else.

The camera needs to be taken apart in order to get at the circuitry inside it. A word of warning here, there is a high-voltage capacitor inside the camera and if it happens to be charged, then it is quite capable of giving you a really nasty shock, so as soon as the circuit board is exposed, I strongly recommend that you take great care to avoid a shock, even though it is not likely to be a fatal shock. As soon as the capacitor is exposed, then short across it's wires using a metal tool which has a plastic handle, such as a screwdriver or pair of pliers with a well-insulated grip. If the capacitor happens to be charged, then that may produce a bright spark which makes a loud crack.

The camera is taken apart like this:

1. The green covering which is a piece of very sticky, strong plastic is peeled off. The join is underneath, where the black colouring ends.
2. In the middle of the bottom, there is a flap which you lever up, uncovering the battery. There are various varieties of Fuji "Quick Snap" camera with different circuitry, the one shown here was supplied by Asda (Wal-Mart in the UK) in 2012 and the circuit board is marked A07 or A60 while some earlier versions have a different layout for some components and even have the battery inserted the other way round. Before you remove the battery which in the UK is a 1.5V AAA alkaline battery, make a careful note of which way round the battery is inserted. In this case, the plus of the battery connects with the long copper arm. Remove the battery.
3. Pull off the black plastic covers on the underside of the camera, located at each end of the battery compartment, and then using a screwdriver, force the two halves of the black camera case apart, which leaves the front of the camera looking like this:



4. Make sure that the flash is not charged, first, by using a non-conducting item to press together the switch contacts marked "A" in the following picture, and then using some metal object with a plastic handle, bridge across the gap between the soldered points ringed around and marked "B" as they are the ends of the high-voltage capacitor. If the capacitor happens to be charged, then there will be a spark and a loud sound, but this is unlikely with a new camera unless you have been pressing the buttons since unwrapping it.

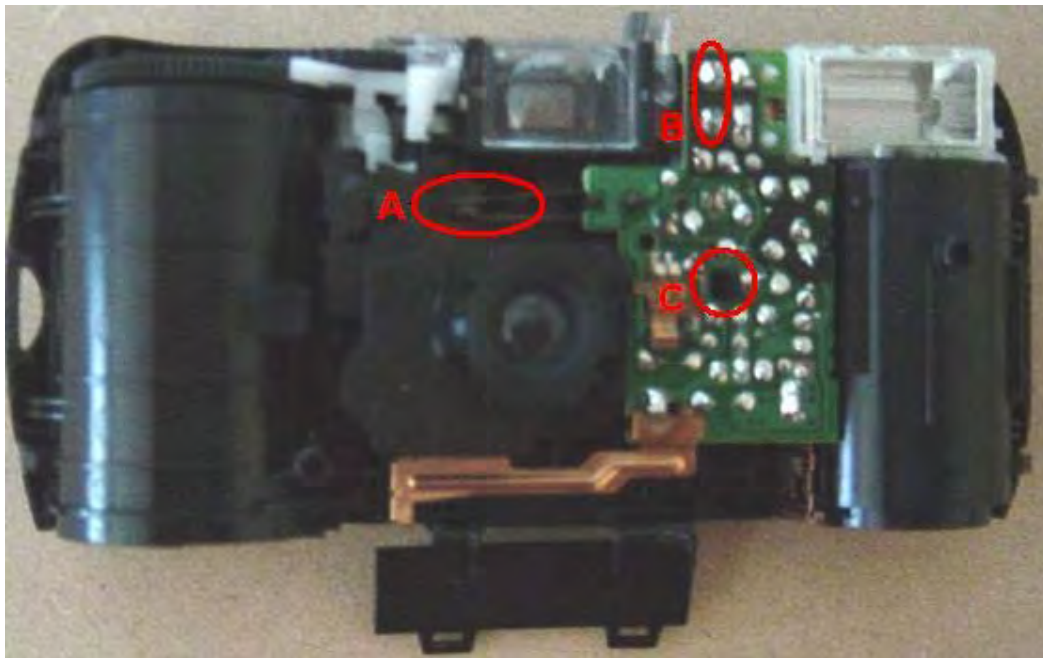

5. Press the black plastic latch marked "C" in the picture above, over towards the left and that releases the circuit board which can be lifted out and looks like this:

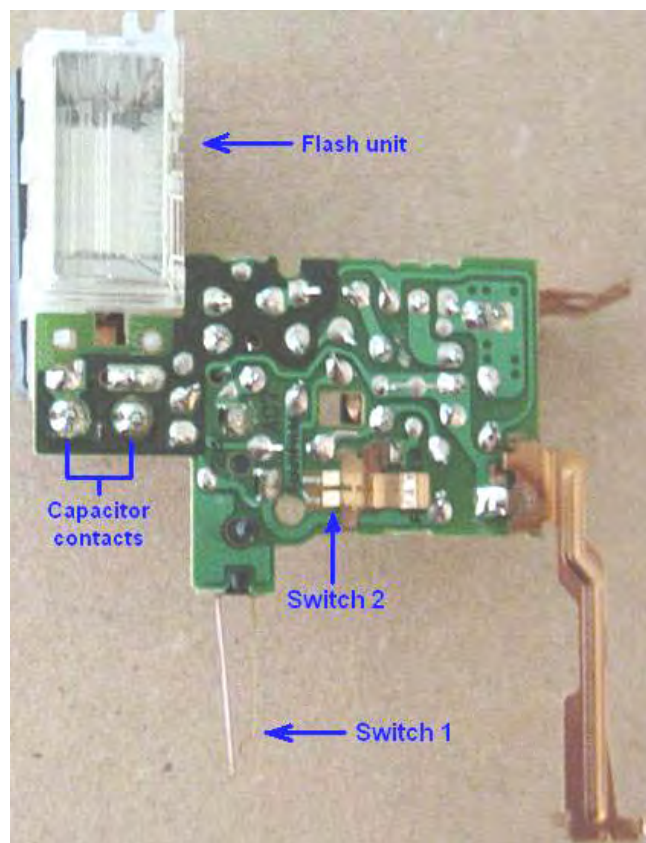

And seen from the top:

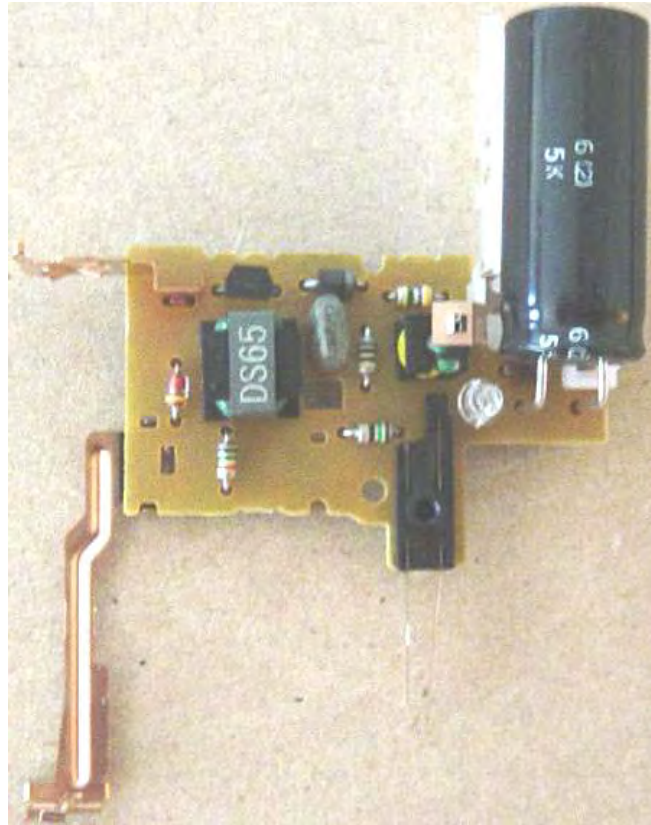

6. The board is quite small, being about 40 mm x 25 mm when the capacitor and flash unit are removed which is the next thing to do, probably by cutting the very tough capacitor leads and then cutting off the plastic pins holding the flash unit to the board, levering it upwards and cutting away its metal contacts which link it to the board.
7. The two switches which form the camera's flash-charging switch and its shutter release switch need to be wired permanently closed. These are marked "Switch 1" and "Switch 2" in step 5. above. I suggest that you cut the arms of Switch 1 to about half length, clamp them together with a pair of long-nosed pliers and bend them over to crimp them flat, and then solder them together. Switch 2 needs to be bridged across to make it permanently closed. A clip can be used to clamp the upper and lower contacts together so that they can be bridged with solder.
8. The rest of the modification is seen from the top of the board:

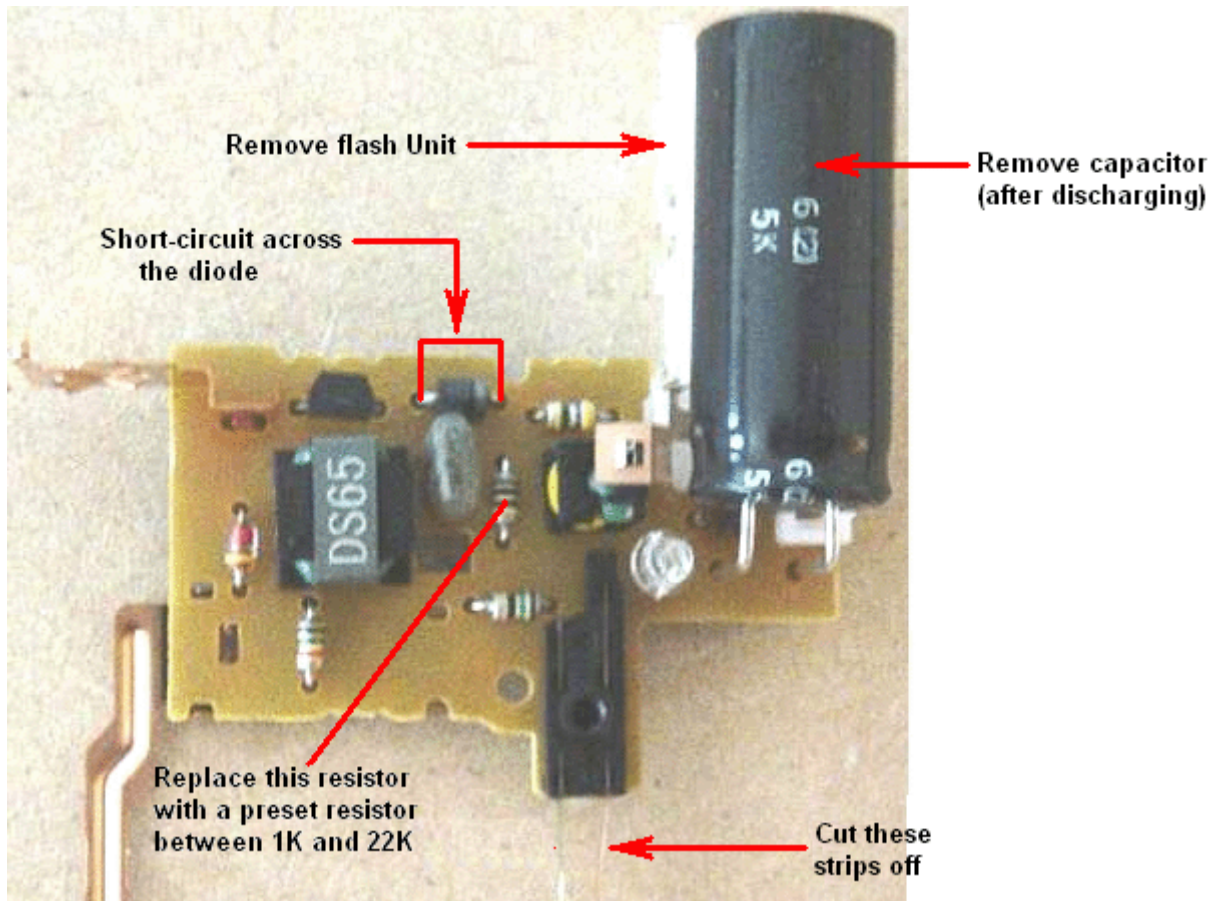

This is to achieve this 'Gadgetmall' circuit:

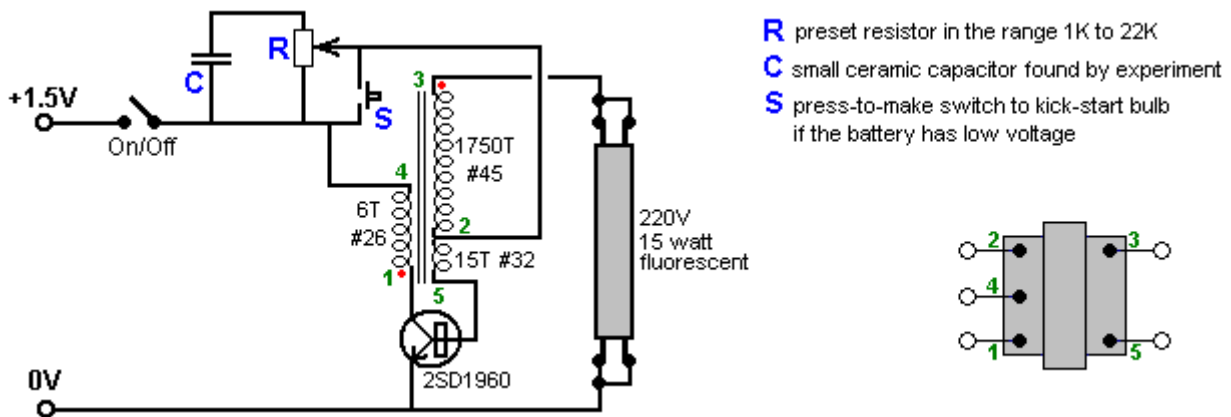

Gadgetmall comments that increasing the voltage supplied to this circuit, puts the 2SD1960 transistor at risk as it will overheat. That transistor is tiny, has no heat sink or space to fit one and was only intended to be on for a few seconds while the capacitor charges up in preparation for operating the flash bulb. This circuit modification runs the transistor continuously for very long periods and so we are already stepping outside the Fuji circuit designer's operating conditions. Also, we would like to run the circuit with somewhat higher voltage in order to get improved operation of the fluorescent tube or bulb. Consequently, we might consider using a more powerful transistor. The 2SD1960 transistor is rated at 30-volts, 5-amps, 170 MHz and 0.75 watts, so we might consider swapping it for, say, a BD245C transistor rated at 100-volts, 10-amps, 3 MHz and 80 watts as our circuit runs at under 0.1 MHz and the BD245C transistor can be mounted on a heat sink, although with it's much greater handling capacity, it should stay cool at these tiny powers. We can boost the gain of the BD245C by a factor of 200 or so, by using a BC109C or a 2N2222 transistor to form a Darlington pair, making the circuit:

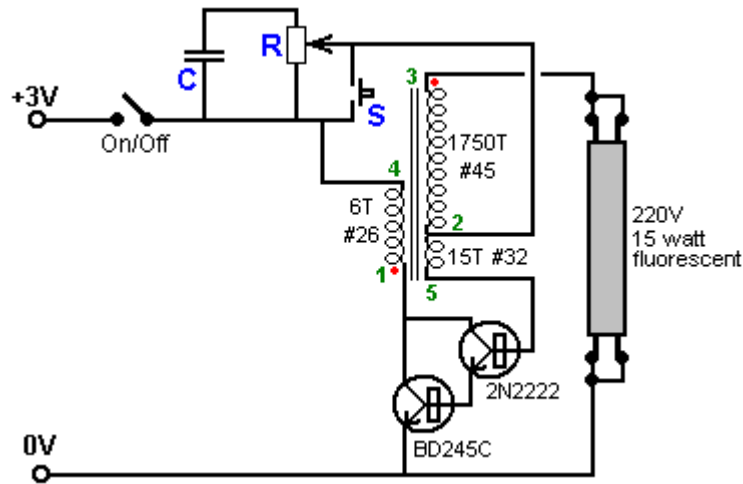

At this point we notice that the only component from the Fuji camera circuit is the ridiculously tiny transformer. However, as that transformer is very cheap and since it appears to work well driving all sorts of fluorescent loads, it does appear to be a worthwhile component in spite of its minute size. The wire sizes used in the transformer are very small, with the #26 AWG wire having a diameter of just 0.4038 mm, the #32 AWG wire a diameter of 0.2032 mm and the #45 AWG having a ridiculously small 0.0447 mm diameter, which means that twenty turns of that wire laid side by side cover less than one millimetre! There is, of course, a strong temptation to wind a ferrite-cored version of this transformer, using larger diameter wires for greater reliability and current handling capacity. That would not be difficult to do as under 1800 turns are involved and the voltages are well within the wire insulation capabilities. However, for the moment we might just use two of the cheap Fuji transformers arranged like this:

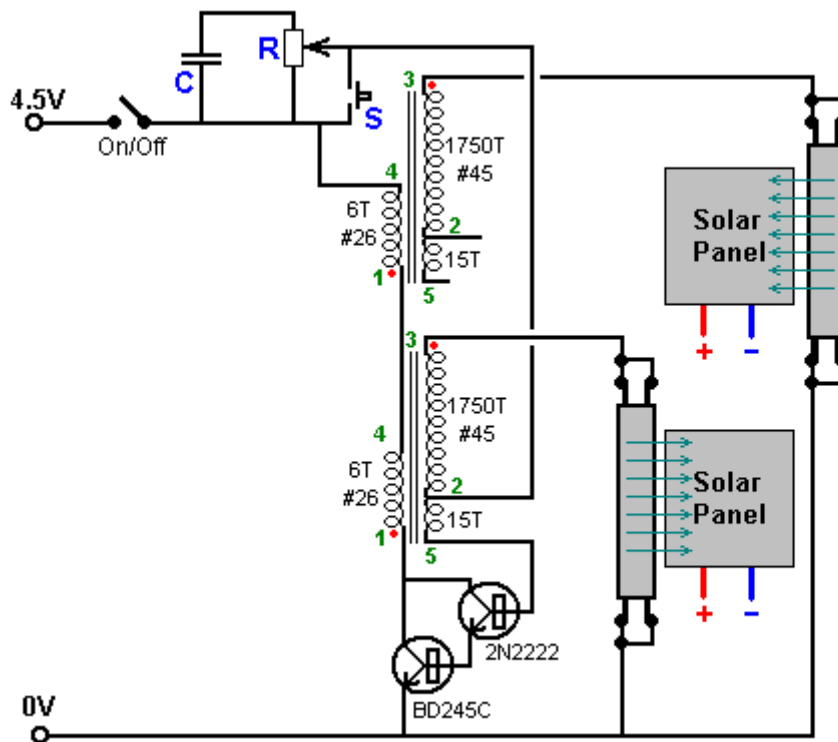

While the circuit shows a long fluorescent tube being driven by each of the output transformers, any type of fluorescent bulb can be driven, and for the long-term practical considerations, one of the PLD plug-in push-fit types would be the optimum choice for a prototype.

This 'Joule Thief' style of circuit is very efficient and draws relatively little current, so if we can replace that small current as it is being drawn, then we will have a self-powered light. There are relatively cheap solar panels measuring just 68 mm square and supposedly providing five volts with a theoretical maximum output of 70 milliamps. It would be excessively optimistic to expect one of these panels illuminated by a fluorescent bulb to produce anything like that amount of current, but with several panels, it should be possible to achieve the necessary current output for continuous operation, especially if the panels are very close to the bulbs. They are 2.5 mm thick and they look like this front and back:



We want to position these panels so that they collect as much light as possible and yet do not obscure the user's light unduly. One obvious position is to use two panels back to back between the two bulbs, where each bulb would obscure the light coming from the other bulb anyway:

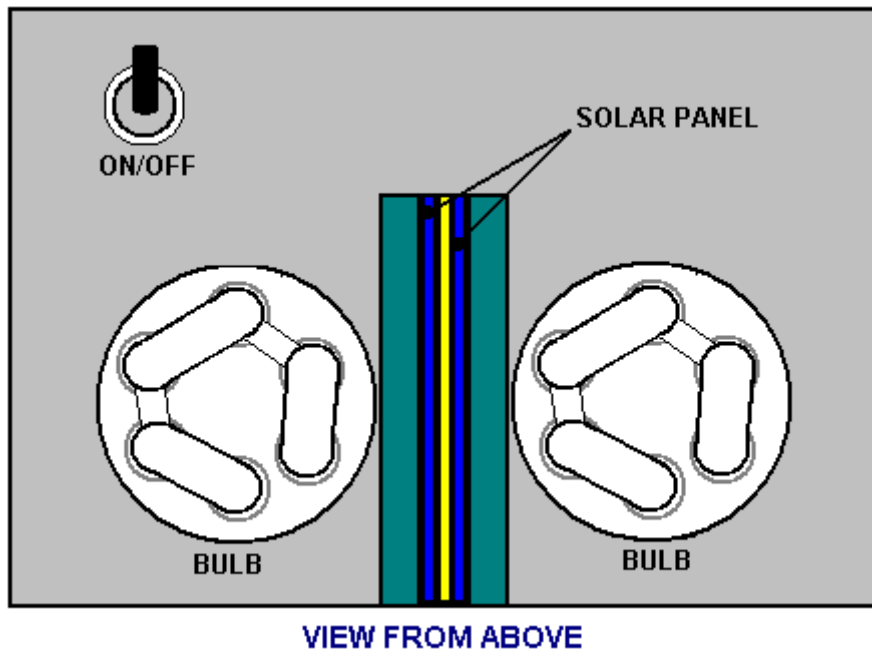

Here, each bulb illuminates the area cast in shadow by the other bulb, giving full 360 degree all-round light as well as giving maximum illumination to two panels. Also, as the bulbs are taller than the panels, the top of each bulb also illuminates the whole of the area.

Seen from the side, it looks like this:

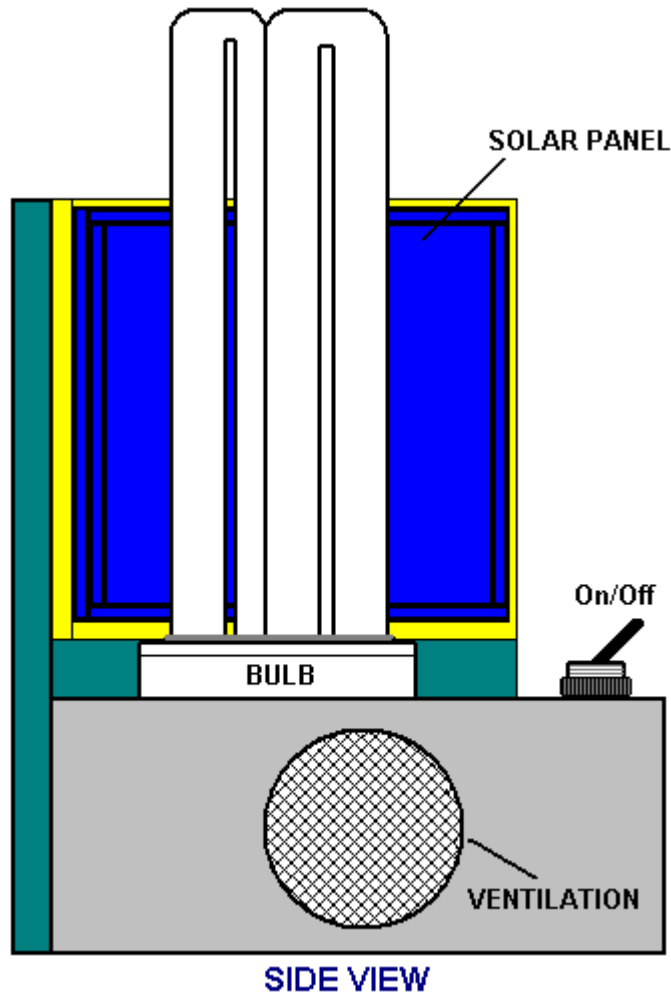

However, whether or not two panels provide sufficient current to meet our needs, (and it needs to be remembered that these bulbs become dimmer as they get old), we would be tempted to add additional panels anyway, in order to provide additional current for other things. Very few light bulbs are arranged to give all-round light as most are mounted on or near walls, ceilings, etc. So we might well be tempted to double the number of panels like this:

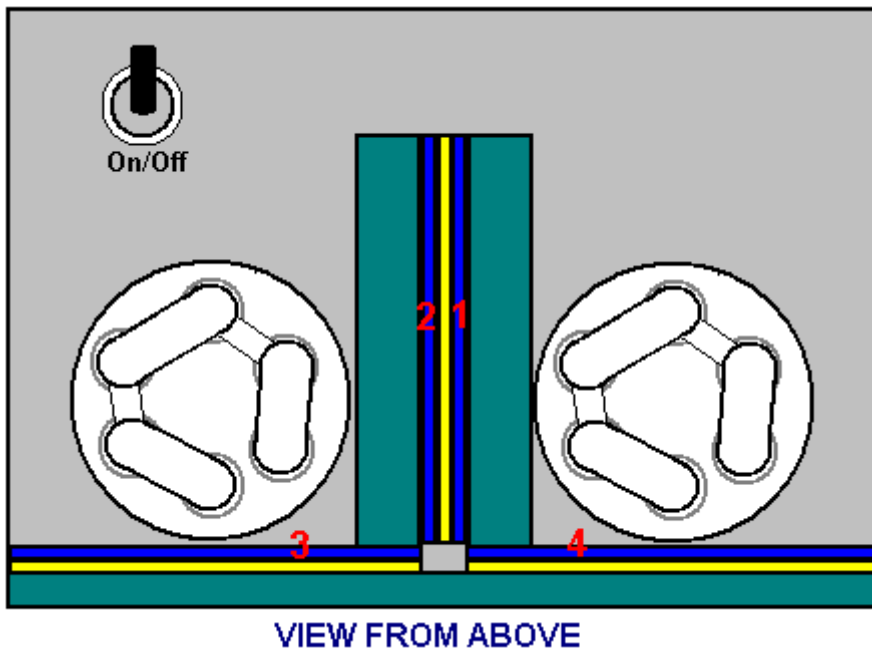

This arrangement is also very good in that it obscures very little of the light which the user would consider to be useful. With four panels, it is unlikely that the current needed for continuous operation of the light bulbs would not be generated by the panels. However, if we provide a USB output socket, the unit could act as a solar panel charger during the day if placed in the sun. (Actually, if we provide enough panels, it might well be able to do that during the night as well). Such an output socket could allow devices such as eBook readers, mobile phones, LED torches, etc. to be charged and that would be a useful additional feature for people who live without mains electricity.

The circuit arrangement might be like this:

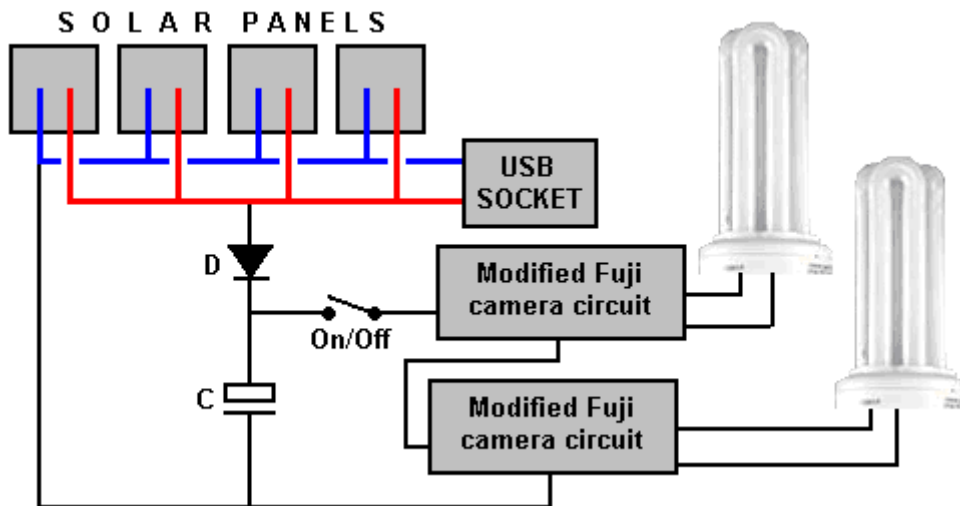

Or like this:

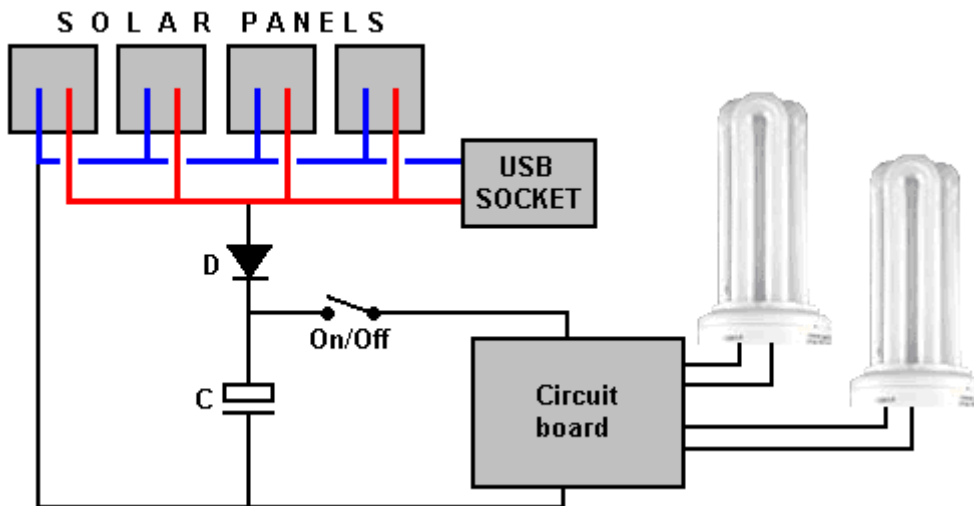

The solar panels are connected directly to the USB output socket and that allows them to act as a straight solar charger when placed in sunlight. The USB connections are like this:



These views are what the user sees when looking at the outside of the socket. Pin 1 is the +5V power line and Pin 4 is the 0V or 'Ground' line. These sockets are readily available and are not expensive. The "B" type is often used when connecting a printer to a computer. If both an "A" type and a "B" type of socket is provided, then a standard 'A to B' USB cable could be used to connect two units together for greater charging capability when placed in sunlight.

In this very simple circuit, a diode "D" passes the output from the panels directly to a large capacitor "C" which charges up quickly to about 0.7 volts less than the panel voltage. There is no need to add in over-voltage protection as the panels are not able to provide more than five volts (unless you were to connect them in series). The diode prevents the USB socket load from discharging the capacitor. Late at night, when the light is turned off and the user goes asleep, the capacitor remains charged as there is no load on it at all. If the capacitor is of good quality, then it will maintain it's charge for a long time, ready to kick off the circuit operation the next time that the light is switched on. There are alternatives to this. For example:

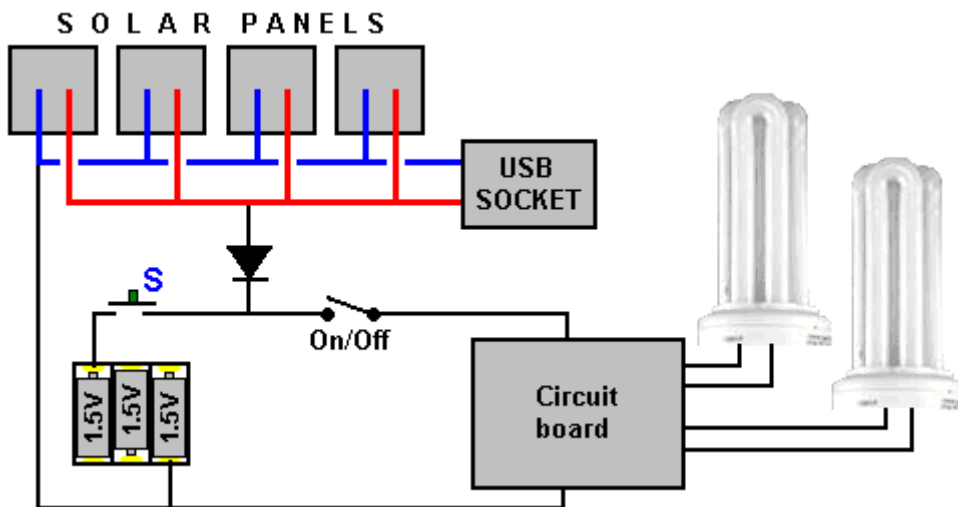

With this arrangement, three AAA dry cells are provided along with a press-button 'press-to-make' switch. The user switches on and then taps the press-button switch to get the circuit running. The batteries should have their normal shelf life as the usage is so trivial. An alternative would be to use three rechargeable batteries (fully

charged when given to the user) as the circuit will keep the rechargeable batteries topped up at all times, in daylight if at no other time, although there should be sufficient output from the panels to provide the absolutely minimal battery power used. If the battery holder is easily accessible, it might well be possible to use the device as a charger for small rechargeable batteries, again, in sunlight if at no other time.

Bulb voltages of 110V or 220V are only related to the circuitry built into the base of the more common bulbs, the actual tubes which light up are all the same. However, it should be noted that all fluorescent tubes generate radiation other than light and so users should stay more than one foot (300 mm) away from a compact fluorescent tube and double that distance when powering the long fluorescent tubes (which can also be driven by this circuit and which have large areas above the tube where panels can be mounted without obscuring any part of the tube or tubes. Please remember that compact fluorescent light bulbs contain highly poisonous mercury and so must **not** be just thrown away as they need to be disposed of carefully to avoid contaminating the local water supply. If a compact fluorescent bulb breaks, then have people and pets leave the room. Do not walk over the affected area. Ventilate the room before you start the clean-up. Mercury vaporises readily at room temperature. Open all windows and leave the room for at least 15 minutes. The broken pieces can be disposed of as normal waste as the mercury has already vaporised.

For people in the UK, there are these suppliers:

The 5-volt, 70 mA 68 mm x 68 mm solar panels: from eBay trader "Discount Devices Ltd." At £3.68 delivered. http://stores.ebay.co.uk/Discount-Devices-Shop?_trksid=p4340.l2563 also the On/Off switch at £1.78 delivered and a pack of ten 1000 microfarad 16V capacitors for £1.78 delivered.

The black ABS box 118 x 98 x 45 mm (Code 400-560) from www.esr.co.uk for £2.11, the BD245C transistor £1.18, heat-sink £0.78, ceramic disc capacitor £0.08, preset resistor £0.15 and the 2N2222A transistor £0.23, all plus VAT plus delivery.

The 18 watt 4-pin PLD fluorescent light bulbs from local hardware store Wilkinsons for £2.95 each. A production version of this light would have bulb sockets but this prototype just had the top of the box cut appropriately and the bulbs inserted and glued in place.

The mesh used for the ventilation holes was cut from a £1.49 "Splatter Guard" of 32 mm diameter, intended to make sure that nothing escapes from a frying pan when it is in use. The adhesive used was Evostick "Impact".

Other panel arrangements might be as shown here:

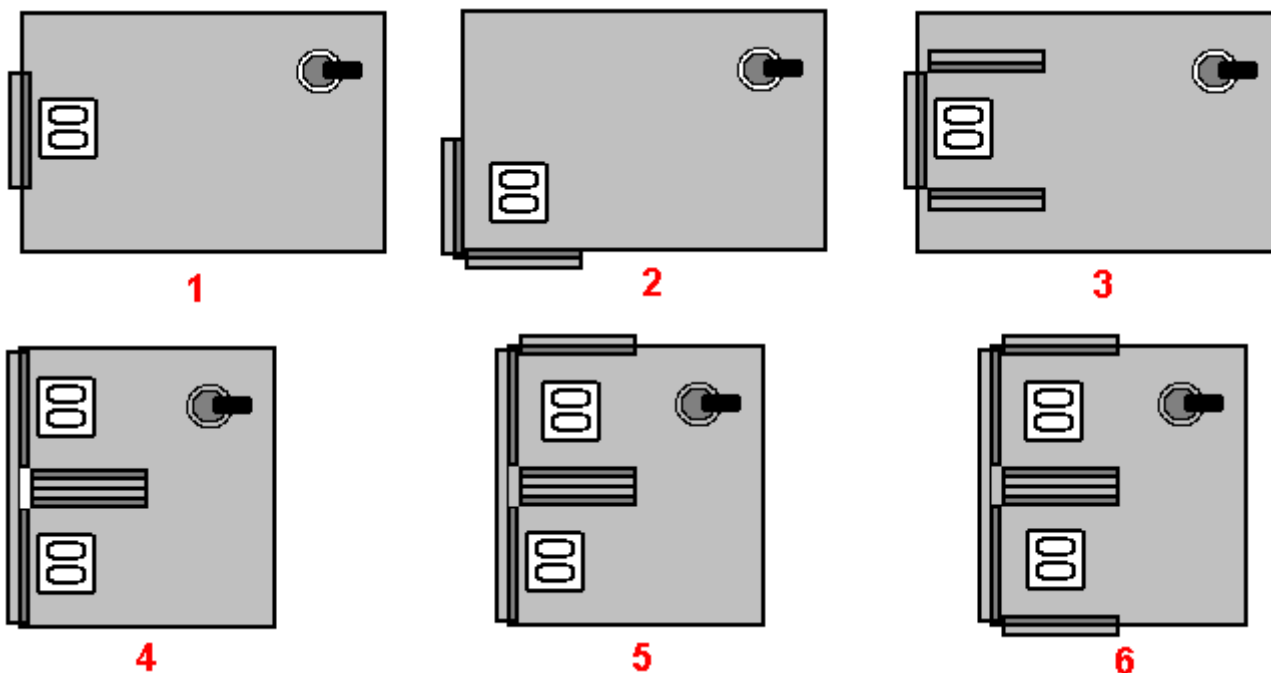

Long tube fluorescent tube fittings usually have plenty of spare space above the tube for mounting the solar panels and the fixing box room for the (insulated) circuit board:

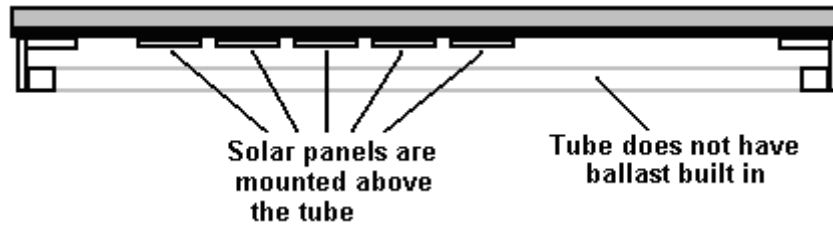

Users should not come closer than 0.5 metres to a fluorescent light fitting of this type, for more than a few minutes at a time. Consequently, the fitting is usually positioned high up, which may make a cord-pull On/Off switch the appropriate type for this style of fitting.

LaserSaber's Joule Thief Lighting Circuits.

Another very successful variation on the basic Joule Thief was put into the Public Domain on 4th October 2012. Details are on his web site www.laserhacker.com. His variation is extremely simple, both in concept and construction:

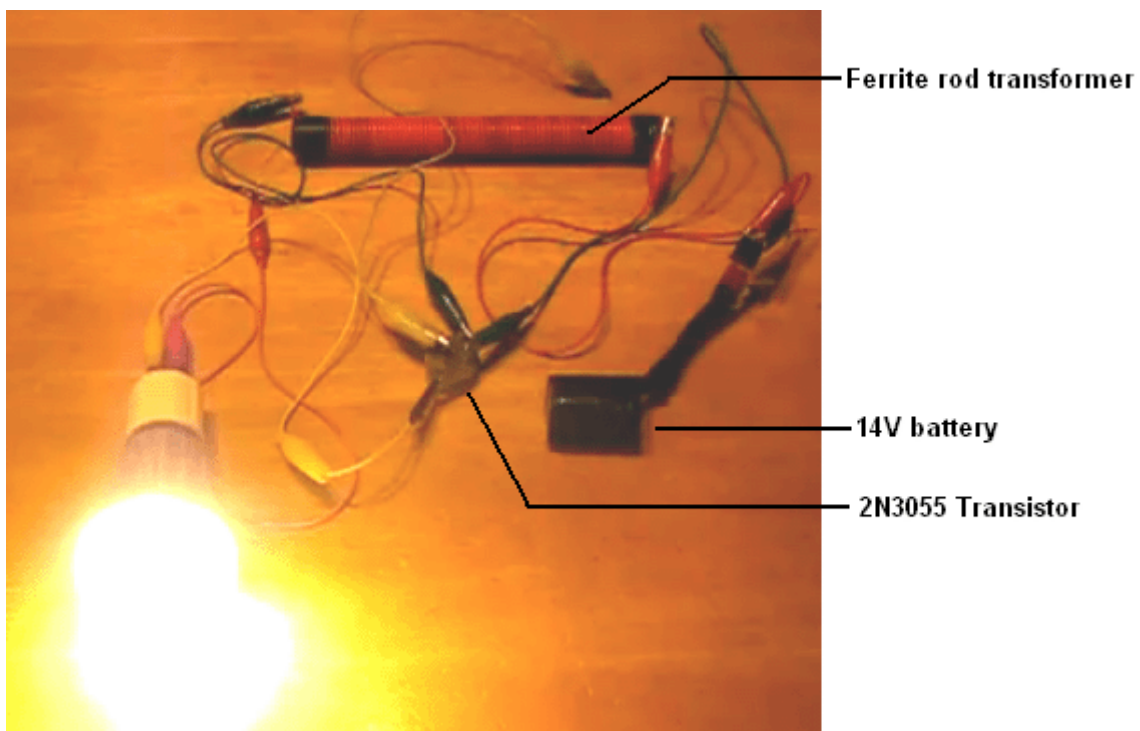

and in his video: <http://solarpower.energygratis.com/2012/10/09/solar-electricity-super-joule-ringer-3-0-real-world-power-made-easy/> he demonstrates it lighting a mains-voltage LED bulb (seen above), a mains filament bulb, a halogen bulb and a compact fluorescent bulb with the ballast still in place, that is, as is sold in shops without any modification. The circuit is:

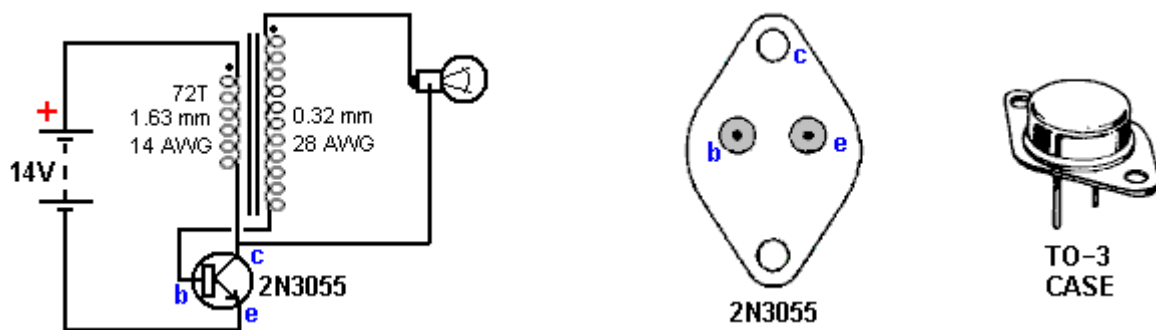

This "Super Joule Ringer 3.0" circuit is unusual in that the feedback to the base of the 2N3055 transistor is through the load (the bulb). The circuit is a high-frequency DC inverter which could hardly be any more simple, but please be aware that the high-frequency output voltage spikes are not sine wave, nor are they voltage

controlled, and so this is not a circuit for driving things like TV sets. The transistor oscillates at high frequency governed by the characteristics of the 72-turn primary winding of the transformer. The output voltage level is a combination of the battery voltage and the turns ratio of the transformer.

To raise the output voltage, the number of turns in the secondary can be increased. The number of turns is not specified, other than to say that the turns are laid close, side-by-side along the whole length of the 8-inch (200 mm) long ferrite rod, using enamelled copper wire of 0.32 mm diameter (28 AWG or 30 swg). Using arithmetic, that would suggest that there are some 600 turns wound directly on to the ferrite rod. The ferrite rod itself has a diameter of 0.625 inches (15.88 mm) which makes it an item which is likely to be difficult to find. However, I strongly suspect that the diameter of the ferrite rod is not at all critical.

Both of the coils are wound on the ferrite rod in the same direction, the secondary being wound first, placing it underneath the primary which is wound with 72 turns of insulated wire of 1.63 mm diameter (14 AWG or 16 swg). No current draw is indicated and it seems likely that it is quite high there being just two helical coils in the drive section. The (110-volt) bulbs demonstrated in his video are:



(BALLASTED) CFL



HALOGEN

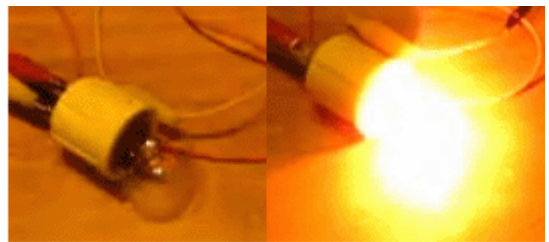

SMALL INCANDESCENT



LED



MEDIUM AND LARGE INCANDESCENTS



A second, very practical lighting system from 'LaserSaber' is a Joule Thief driven LED lighting box, running from just one AA rechargeable battery. It looks like this:



Mounted on the end of the box is a single small solar panel:



which is able to charge the battery during the day. The unit is built into a small box which opens up to allow easy wiring, and different angles for positioning the LED lights. Not seen in these pictures is one other large LED cluster light which is also lit. It is a slight pity that the case does not allow the LED lights to shine on the solar panel when the lights are on, as that would provide some battery charging when the light is being used. The LED lights can provide a good deal of light:



A video of this unit being demonstrated is at <http://www.youtube.com/watch?v=sFpzkyP6DCU>.

Ed Gray's Power System.

The power tube presented to the public by Edwin Gray snr. operates by generating a series of very short, very sharp pulses using a spark gap. This device is reputed to have a power output which is one hundred times that of the power input. Ed Gray and his electric pulse motor are very famous, but as far as I am aware, nobody has successfully replicated this claimed performance. Further, an in-depth examination of the background details by Mr Mark McKay have turned up a number of facts which present a very different picture, and while it is perfectly correct to say that spark-gap pulses generate a good waveform for shocking the local zero-point energy field into the sort of imbalance which can provide a massive power inflow into a device or circuit, we need to be careful to get the full facts in this case.

First, let us put the whole thing in its proper perspective. In May 1973, Cal-Tech in the US performed an independent assessment of an engine provided to them by Edwin Gray. They measured the input and the output and certified that the output power was 275 times greater than the input power. This demonstrates clearly that

excess power can be drawn into an engine and provide a performance which can power both the engine as well as doing additional useful work.

Having said that, it needs to be made clear that Edwin Gray did not build that small motor, did not understand how it worked, nor did he ever disclose the design in any of the patents which he obtained afterwards. We need to follow the sequence of events and notice when each thing happened. The history is as follows:

In 1957, a Russian immigrant to the USA, one Alexei Poppoff, showed Edwin Gray a circuit which he said that he had been shown by Nikola Tesla. Edwin Gray did not understand the circuit and had no idea how to create anything useful based on it. He then joined up with his next-door neighbour Marvin Cole, who held a Masters degree in Mechanical Engineering and who, unlike Gray, was able to understand the circuitry.

In 1958, Ed Gray left the Los Angeles area in a hurry.

From 1958 to 1967 Marvin Cole, working alone, designed and built ever more powerful prototype engines, and it was a small one of these which was tested by Cal-Tech. In this period, Marvin also developed ever more powerful power supplies, which are the really important item in all of this.

In 1967, Ed Gray rejoins Marvin Cole and together from 1967 to 1972 they solicited venture capital and promoted the technology.

Early in 1972, Marvin Cole disappeared and never saw Gray again. It is not clear if he was intimidated, died, or just did not want to be involved in all the publicity and effort needed to turn the prototype engines into a commercial product. No matter what the reason, the result was that Edwin Gray was suddenly disconnected from the brains behind the project, and that left him in a very difficult position. He didn't want to let go of the dream of becoming rich through this spectacular development, and so he tried to continue the development on his own.

As already mentioned, in May of the following year (1973), Gray had a small Marvin Cole motor independently third-party tested at the famous Cal-Tech laboratory in Los Angeles, where a measured input of just 27 watts produced a measured output of 10 horsepower (7460 watts). The objective was to provide solid evidence of a new technology which was capable of changing the world and so would attract investors. To further boost his image and convince potential investors, in that same year of 1973, Edwin staged demonstrations which jumped electromagnets up into the air, showing the strength of the power which drove the Marvin Cole engines.

It is very important to understand that all of Edwin Gray's patents were applied for after the departure of Marvin Cole. These do not disclose the technology tested by Cal-Tech and it must be understood that Edwin was very much afraid of revealing anything important in any of the patents in case some other person would understand the things which were a mystery to him and snatch away the prize of commercial success. Try watching Peter Lindemann's informative video at <http://www.youtube.com/watch?v=dmf10hggUm4> for considerable additional information.

Marvin Cole's power system produced "cold electricity" which could power lights and other devices. It was frequently demonstrated that the output was not conventional electricity and powered light bulbs which were placed under water and at the same time, it was quite safe for a hand to be put into that same water along with the lit bulb. The glass of the conventional bulbs used in these demonstrations would have shattered when placed under water if they had been powered by conventional "hot electricity" as the sudden change in temperature would have broken the glass. Powered as they were by "cold electricity", they ran cool and so there was no stress on the glass when submerged in water.

Peter Lindemann points out that Ed Gray's power conversion tube circuit is effectively a copy of Nikola Tesla's circuit for doing the same thing:

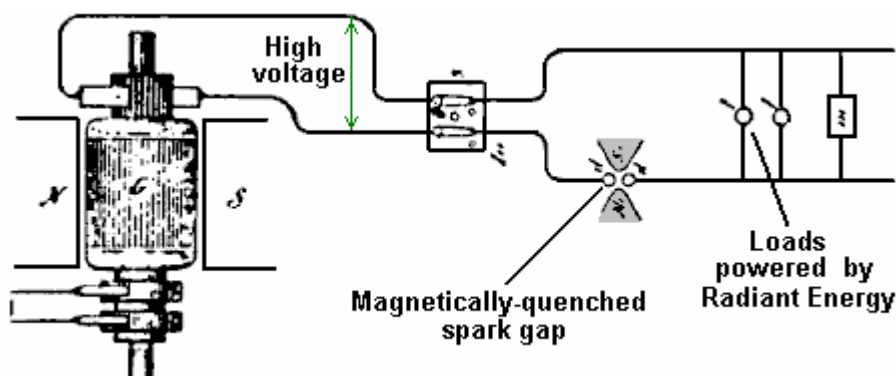

This was disclosed by Tesla in his 'Philadelphia and St Louis' lecture in 1893 and shows how loads can be powered when a high voltage source is pulsed by a magnetically-quenched sparks - this creates DC pulses of **very** short duration.

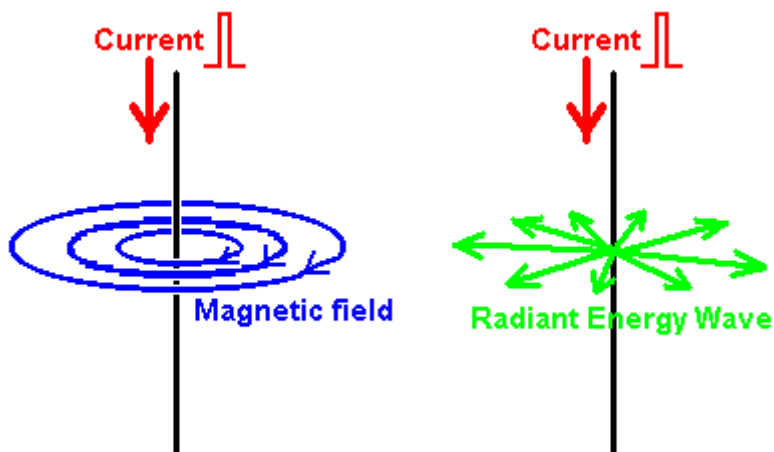

The diagram above, illustrates the difference between the Magnetic field generated around a conductor fed with a pulse of Direct Current and the Radiant Energy waves created by that pulse. If a sharp current pulse is driven down a vertical wire, it causes two different types of field. The first field is magnetic, where the lines of magnetic force rotate around the wire. These lines are horizontal, and rotate clockwise when viewed from above. The magnetic field remains as long as the current flows down the wire.

The second field is the Radiant Energy wave. This wave will only occur if the current pulse is in one direction, i.e. it will not occur if the wire is fed with alternating current. The wave radiates out horizontally from the vertical wire in every direction in the form of a shock wave. It is a one-off event and does not repeat if the current in the wire is maintained. The Radiant Energy briefly unbalances the zero-point energy field and that causes an energy flow as the field moves back into equilibrium again.

The Radiant energy wave is not restricted to a single plane as shown in the diagram above, which is intended to indicate the difference between the electromagnetic field circling around the wire, and the Radiant Energy field which radiates away from the wire. Both of these fields occur at all points along the full length of the wire as shown here:

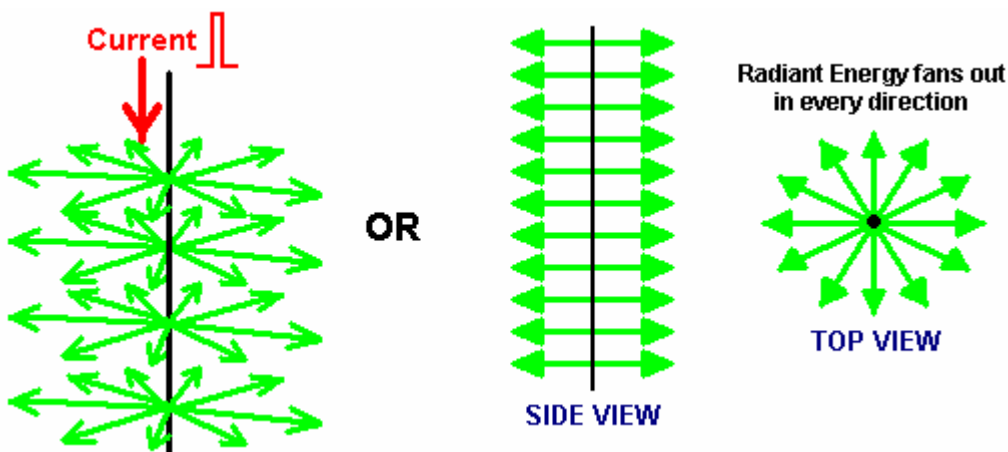

Radiant Energy, when converted to electrical power, produces a different kind of electrical power to that produced by batteries and by the mains supply. Power a motor with conventional electricity and it gets hot under load. Power the same motor by Radiant Energy electricity and under load the motor gets cold. Really overload it by stalling it and the motor housing is likely to be covered with frost. That is why this form of electricity is referred to as "cold" electricity.

In his book "Cold War Secrets - HAARP and Beyond", Gerry Vassilatatos quotes research work done in this area by Tesla and others:

Tesla's Experiments.

In 1889 Tesla began experimenting with capacitors charged to high voltages and discharged in very short time intervals. These very short pulses produced very sharp shockwaves which he felt across the front of his whole body. He was aware that closing a switch on a high-voltage dynamo often produced a stinging shock. This was believed to be static electricity and it occurred only at switch-on and only for a few milliseconds. However, in those few milliseconds, bluish needles of energy stand out from the electrical cables and they leak to ground, often through the bodies of any people standing nearby, causing immediate death if the installation is large. While the generators of that time were rated at some thousands of volts, these discharges were millions of volts in intensity. The generator problem was eliminated by the use of highly insulated switches which were provided with a very large ground connection.

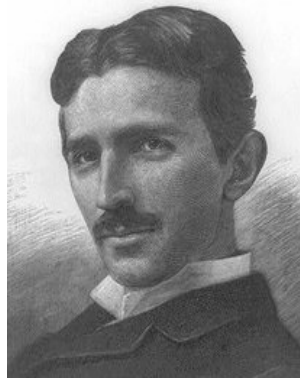

Tesla was intrigued by this phenomenon which appeared to match the effect of his capacitor discharges. He calculated that the voltages produced were hundreds of times greater than could be supplied by the capacitor or generator. It was clear that the power supplied was being amplified or augmented in some way, but the question was, from where was the extra energy coming?

Tesla continued to investigate through experiments, taking precautions against the high voltages being produced. He was soon able to produce these shockwaves whenever he wanted to. The shockwaves produced a stinging sensation no matter where he stood in his laboratory, and hands and face were particularly sensitive to the wave. These waves radiated out and penetrated metal, glass and every other kind of material. This was clearly not an electromagnetic wave, so he called the new wave 'Radiant Electricity'.

Tesla searched the literature to find references to this radiant energy but he could not find much. In 1842, Dr. Joseph Henry had observed that steel needles were magnetised by a Leyden Jar spark discharge located on a different floor of the building. The magnetising wave had passed through brick walls, oak doors, heavy stone and iron flooring and tin ceilings to reach the needles located in a vault in the cellar.

In 1872, Elihu Thomson took a large Ruhmkorff Spark Coil, attached one pole of the coil to a cold-water pipe and the other pole to a metal table top. This resulted in a series of massive sparks which electrified the metal door knob of the room and produced the stinging shockwaves which Tesla was investigating. He found that any insulated metal object anywhere in the building would produce long continuous white sparks discharging to ground. This discovery was written up briefly in the Scientific American journal later that year.

Tesla concluded that all of the phenomena which he had observed, implied the presence of "a medium of gaseous structure, that is, one consisting of independent carriers capable of free motion - besides the air, another medium is present". This invisible medium is capable of carrying waves of energy through all substances, which suggests that, if physical, its basic structure is much smaller than the atoms which make up commonplace materials, allowing the stream of matter to pass freely through all solids. It appears that all of space is filled with this matter.

Thomas Henry Moray demonstrated this energy flow passing through glass and lighting standard electric light bulbs. Harold Aspden performed an experiment known as the "Aspden Effect" which also indicates the presence of this medium. Harold made this discovery when running tests not related to this subject. He started an electric motor which had a rotor mass of 800 grams and recorded the fact that it took an energy input of 300 joules to bring it up to its running speed of 3,250 revolutions per minute when it was driving no load.

The rotor having a mass of 800 grams and spinning at that speed, its kinetic energy together with that of the drive motor is no more than 15 joules, contrasting with the excessive energy of 300 joules needed to get it rotating at that speed. If



the motor is left running for five minutes or more, and then switched off, it comes to rest after a few seconds. But, the motor can then be started again (in the same or opposite direction) and brought up to speed with only 30 joules **provided** that the time lapse between stopping and restarting is no more than a minute or so. If there is a delay of several minutes, then an energy input of 300 joules is needed to get the rotor spinning again.

This is not a transient heating phenomenon. At all times the bearing housings feel cool and any heating in the drive motor would imply an increase of resistance and a build-up of power to a higher steady state condition. The experimental evidence is that there is something unseen, which is put into motion by the machine rotor. That "something" has an effective mass density 20 times that of the rotor, but it is something that can move independently and take several minutes to decay, while the motor comes to rest in a few seconds.

Two machines of different rotor size and composition reveal the phenomenon and tests indicate variations with time of day and compass orientation of the spin axis. One machine, the one incorporating weaker magnets, showed evidence of gaining strength magnetically during the tests which were repeated over a period of several days.

This clearly shows that there is an unseen medium which interacts with everyday objects and actions, and confirms Tesla's discovery. Tesla continued to experiment and determined that a very short uni-directional pulse is necessary to generate the radiant energy wave. In other words, an alternating voltage does not create the effect, it has to be a DC pulse. The shorter the pulse time and the higher the voltage, the greater the energy wave. He found that using a capacitor and an arc discharge mechanism with a very powerful permanent magnet placed at right angles to the spark, improved the performance of his equipment by a major factor.

Additional experiments showed that the effects were altered by adjusting the duration of the electrical pulse. In each instance, the power of the radiated energy appeared to be constant irrespective of the distance from his apparatus. The energy was in the form of individual longitudinal waves. Objects placed near the equipment became powerfully electrified, retaining their charge for many minutes after the equipment was switched off.

Tesla was using a charging dynamo as a power source and he found that if he moved his magnetic discharger to one side of the dynamo, the radiant wave was positive. If he moved the magnetic discharger towards the other side of the dynamo, the radiant wave became negative in sign. This was clearly a new electrical force which travelled as light-like rays, showing them to be different in nature to the electromagnetic waves of Maxwell.

Investigating the effects of adjusting the duration of the pulses, Tesla found that a pulse train which had individual pulses with durations exceeding 100 microseconds, produced pain and mechanical pressures. At this duration, objects in the field visibly vibrated and were even pushed along by the field. Thin wires subjected to sudden bursts of the radiant field, exploded into vapour. When the pulse duration was reduced to 100 microseconds or below, the painful effect was no longer felt and the waves are harmless.

With a pulse duration of 1 microsecond, strong physiological heat was felt. With even shorter pulse durations, spontaneous illuminations capable of filling rooms with white light, were produced. Even shorter pulses produced cool room penetrating breezes with an accompanying uplift in mood and awareness. These effects have been verified by Eric Dollard who has written about them in some detail.

In 1890, Tesla discovered that if he placed a two-foot long single-turn deep copper helix coil near his magnetic disrupter, the thin-walled coil developed a sheath of white sparks with long silvery white streamers rising from the top of the coil. These discharges appeared to have much higher voltages than the generating circuit. This effect was greatly increased if the coil was placed inside the disrupter wire circle. The discharge seemed to hug the surface of the coil with a strange affinity, and rode up its surface to the open end. The shockwave flowed over the coil at right angles to the windings and produced very long discharges from the top of the coil. With the disrupter charge jumping one inch in its magnetic housing, the coil streamers were more than two feet in length. This effect was generated at the moment when the magnetic field quenched the spark and it was wholly unknown at that time.

This train of very short uni-directional pulses causes a very strange field to expand outwards. This field resembles a stuttering electrostatic field but has a far more powerful effect than would be expected from an electrostatic charge. Tesla was unable to account for the enormous voltage multiplication of his apparatus using any of the electrical formula of his day. He therefore presumed that the effect was entirely due to radiant transformation rules which would have to be determined through experimental measurements. This he proceeded to do.

Tesla had discovered a new induction law where radiant shockwaves actually auto-intensified when encountering segmented objects. The segmentation was the key to releasing the action. Radiant shockwaves encountered a helix and "flashed over" the outer skin, from end to end. This shockwave did not pass through the windings of the coil but treated the surface of the coil as a transmission path. Measurements showed that the voltage increase

along the surface of the coil was exactly proportional to the length travelled along the coil, with the voltage increase reaching values of 10,000 volts per inch of coil. The 10,000 volts which he was feeding to his 24 inch coil were being magnified to 240,000 volts at the end of his coil. This was unheard of for simple equipment like that. Tesla also discovered that the voltage increase was mathematically linked to the resistance of the coil winding, with higher resistance windings producing higher voltages.

Tesla then began to refer to his disrupter loop as his special "primary" and to the long helical coil as his special "secondary" but he never intended anyone to equate these terms to those referring to electromagnetic transformers which operate in a completely different way.

There was an attribute which baffled Tesla for a time. His measurements showed that there was no current flowing in the long copper 'secondary' coil. Voltage was rising with every inch of the coil, but there was no current flow in the coil itself. Tesla started to refer to his measured results as his "electrostatic induction laws". He found that each coil had its own optimum pulse duration and that the circuit driving it needed to be 'tuned' to the coil by adjusting the length of the pulses to give the best performance.

Tesla then noticed that the results given by his experiments paralleled the equations for dynamic gas movements, so he began wondering if the white flame discharges might not be a gaseous manifestation of electrostatic force. He found that when a metal point was connected to the upper terminal of the 'secondary' coil, the streamers were directed very much like water flowing through a pipe. When the stream was directed at distant metal plates, it produced electronic charges which could be measured as current at the receiving site but in transit, no current existed. The current only appeared when the stream was intercepted. Eric Dollard has stated that this intercepted current can reach several hundred or even thousands of amps.

Tesla made another remarkable discovery. He connected a very heavy U-shaped copper bar directly across the primary of his disrupter, forming a dead short-circuit. He then connected several ordinary incandescent filament bulbs between the legs of the U-shaped bar. When the equipment was powered up, the lamps lit with a brilliant cold white light. This is quite impossible with conventional electricity, and it shows clearly that what Tesla was dealing with was something new. This new energy is sometimes called "cold electricity" and Edwin Gray snr. demonstrated how different it is by lighting incandescent-filament bulbs directly from his power tube, submerging them in water and putting his hand in the water. Cold electricity is generally considered to be harmless to humans. Ed Gray's power tube operates by generating radiant electricity waves by using a spark gap, and collecting the energy using three encasing copper cylinders surrounding the spark gap. The cylinders are drilled with many holes as that enhances the pick-up and the load is driven directly from the current in the cylinders. When lighting bulbs, Ed used an air-cored transformer made of just a few turns of very heavy wire. I, personally, am aware of two people who have independently reproduced Ed's power tube.

Tesla viewed the streamers coming off his coils as being wasted energy so he tried to suppress them. He tried a conical coil but found that this accentuated the problem. He then tried placing a copper sphere at the top of his coil. This stopped the streamers but electrons were dislodged from the copper sphere, creating really dangerous conditions. This implied that metals generate electron flows when struck by the coil streamers (as had been seen when the streamers had been aimed at remote metal plates and current was generated as a result).

Tesla designed, built and used large globe lamps which required only a single external plate for receiving the radiant energy. No matter how far away these lamps were from the radiant source, they became brilliantly lit, almost to the level of an arc lamp and far, far brighter than any of the conventional Edison filament lamps. By adjusting the voltage and the pulse duration of his apparatus, Tesla could also heat or cool a room.

Tesla's experiments suggest that a method of extracting free-energy is to use a Tesla coil which has a metal spike instead of the more common metal sphere at the end of the 'secondary' coil. If the Tesla coil is fed with sufficiently short uni-directional pulses and the 'secondary' coil pointed at a metal plate, then it should be possible to draw off serious levels of power from the metal plate, just as Tesla discovered. This has been confirmed by Don Smith who uses two metal plates separated by a layer of plastic dielectric, forming a capacitor. He states that a well designed Tesla coil is capable of producing currents as high as the voltages and he demonstrates a hand-held 28 watt Tesla Coil played on the first plate producing a substantial continuous spark discharge between the second plate and ground. I estimate that the spark produced would have to be thousands of volts at a significant current, which puts it in the kilowatt range, like most of Don's other devices. Video: http://www.metacafe.com/watch/2820531/don_smith_free_energy/ Don's patent is in Chapter 3 and his .pdf document here: <http://www.free-energy-info.tuks.nl/Smith.pdf> in which he explains many of his high-power designs.

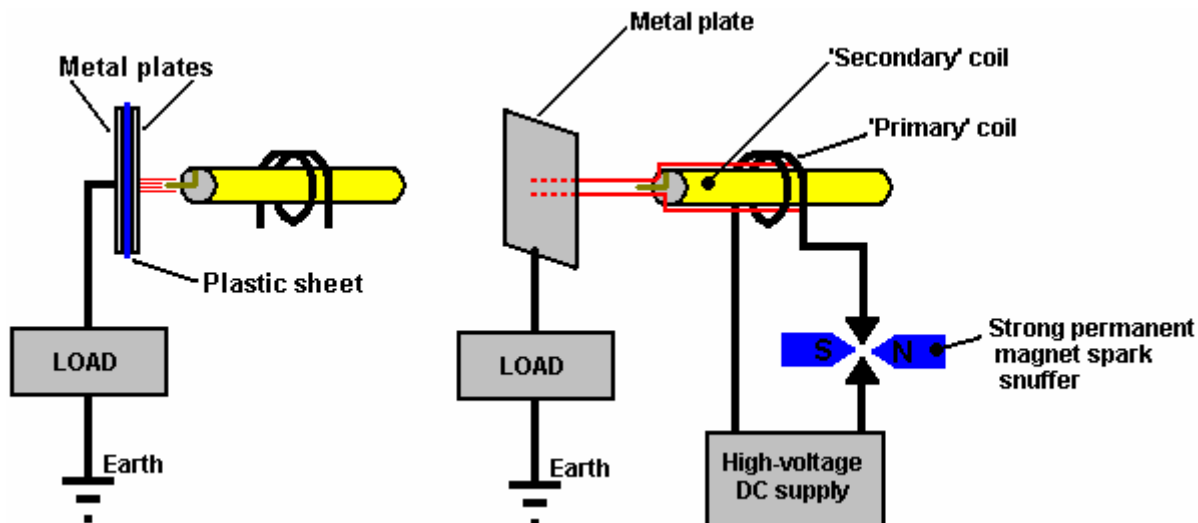

Don also points out that the positioning of the primary coil relative to the secondary coil of a Tesla Coil determines the amount of current which can be provided. Contrary to most opinion, it is possible to have Tesla Coil current as high as the voltage. Don always stresses that you have the option of picking the electrical component (as conventional science has done) which leads to "heat death" while the alternative option of selecting the magnetic component makes "the world your oyster". With a magnetic ripple imposed on the zero-point energy field, which Don prefers to call the 'ambient background energy', you can make as many electric conversions as you wish, without depleting the magnetic event in any way. In other words, you can draw off serious amounts of current from capacitor plates positioned at right angles to the magnetic flow, and every additional pair of plates gives you an additional source of major current without any need to increase the magnetic disturbance in any way. With his single metal plate, Tesla mentioned currents of a thousand amps being available. Please remember that a Tesla Coil produces seriously high voltages and is **not** a toy. Great care is needed around a Tesla Coil so, when it is running, keep well away from it.

Don also states that the collection and transfer of energy requires temporary storage which occurs as the capacitors and coils of a resonant circuit are cycled on and off. The frequency at which the capacitors and coils are pumped, determines the amount of electrical energy that moves onwards. The amount of Energy transferred relates directly to the density of lines of magnetic flux present. The Kinetic Energy formula is helpful in establishing the amount of energy present. This formula points to mass multiplied by the square of the velocity. In the case of electrical energy, intensity of voltage and amperes multiplied by cycles per second, replace velocity. Note that the "acceleration" of the Voltage and the Amperage, increases in a non-linear fashion as the Law of Squares applies, with each unit of increase causing a squaring of the flux lines present. In resonant air-core coil energy transfer, the increase in flux lines present disturbs more electrons than previously and this results in greater output energy than input energy being present and available.

Energy stored, multiplied by the cycles per second, is the energy being pumped by the system. Capacitors and inductors (coils) temporarily store electrons.

Capacitor formula: $W = 0.5 \times C \times V^2 \times \text{Hz}$ where:

- W is the energy in Joules (Joules = Volts x Amps x seconds)
- C is the capacitance in Farads
- V is the voltage
- Hz is the cycles per second

Inductor formula: $W = 0.5 \times L \times A^2 \times \text{Hz}$ where:

- W is the energy in Joules
- L is the inductance in Henrys
- A is the current in amps
- Hz is the frequency in cycles per second

Both one Henry and one Farad equal one volt. The higher the frequency, including the squaring of the flux lines, causes a large increase in the amount of energy being produced. This, combined with the use of a resonant energy induction system (all electrons moving in the same direction at the same time), make the move into COP>1 practical.

The damping process of conventional electrical power generation, has all of the available electrons bouncing randomly, mostly cancelling out each other, and so the useful energy available is only a very small percentage of the energy which is present. In a resonant induction system, a very high percentage of the energy present is useful. When resonating, (ohms-impedance-Z) becomes zero and all of the energy present becomes available, without being degraded in any way. Ohms is load or wasted energy and amperes is the rate of that wasting.

Now, apply this information to an air-core coil resonant transformer energy system. L-1 and L-2 coils are now present. L-1 has fewer turns and is several times the diameter of L-2. Input from a 12-volt 'gelcel' high-voltage laser module, produces 8,000 volts with low (wasted energy) amperage into 4 turns of coil L-1. Each turn of L-1 then acquires 2,000 volts of resonant potential. Each turn of L-2 is then exposed to an electric flux of 2,000 volts. Each turn at the bottom end of L-2 acquires 2,000 volts. The flux lines are squared and are additive as the voltage and amperage progress towards the top end of L-2's many turns.

A huge number of flux lines which were not previously present, occur at the top end of L-2. These flux lines excite the electrons nearby in it's earth and air and groundings. This high level of excitement above the ambient, causes a large number of electrons to become available, electrons which previously, were not part of the energy present. At this point, large amounts of excess energy is present. This COP>1 device produces energy at radio frequencies in the megahertz range and this allows it to be small in size and yet produce large amounts of energy. A megawatt sized unit will sit comfortably on a breakfast table. The energy is changed to direct current, and then, to the desired working frequency.

The energy powering these devices is drawn from the surrounding energy field and is not conventional electricity and it does not flow through the wire of the 'secondary' coil, but instead, it runs along the outside of the coil and through space to strike the surface of the metal plate, where it generates conventional electric current. Thomas Henry Moray demonstrated that this energy flowing along the outside of the wire can pass through glass without being affected in any way.

In his 1995 paper Don Smith presents the following diagram:

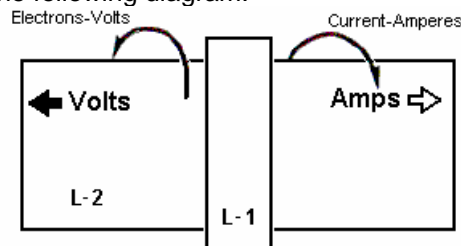

**Volts dominate if the L-1 coil is far right
Volts and Amps are about equal if L-1 is central**

**This end has greater Voltage
Distributive Capacitance at maximum
Capacitance-Coulombs-Voltage
Voltage has electrons spinning
to the left**

**This end has greater Amperage
Distributive Inductance at Maximum
Induction-Henrys-Amperage
Amperage has electrons spinning
to the right**

**Volts represent the more negative and Amperes the
less negative. Therefore, the electrical charge of more
negative must seek the less negative to regain ambient.**

While Tesla's experiment used a metal plate, he patented (US 512,340) a coil type which he said is very effective in picking up this radiant energy. This "pancake" coil type goes by the rather impressive name of "bi-filar serial-connected coil", which, despite it's impressive name is not difficult to wind using two separate strands of wire as shown here:

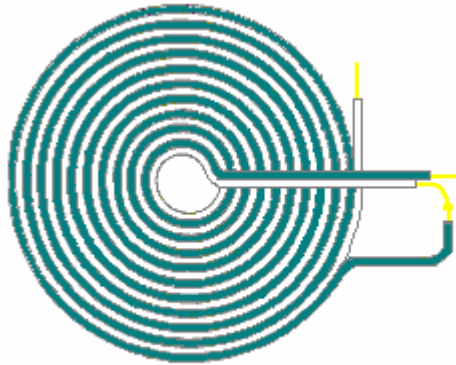

**Flat 'pancake' coil winding
method patented by Nikola Tesla**

If a strong magnetic field is positioned across the spark gap as shown above, it sharpens the cut-off of the spark and enhances the uni-directional character of the pulse of current. It should be remembered that if a very short sharp pulse of uni-directional current such as is produced by a spark jumping across a spark gap as in the arrangement shown above, occurs in a conductor, then a strong wave of radiant energy radiates out in a plane at right angles to the pulse of current.

This radiant energy wave is quite different from the electromagnetic field generated around the wire carrying the pulse of current. In the Tesla coil arrangement shown above, it should be possible to gather additional free energy through one or more co-axial (like layers of an onion) cylindrical coils around the spark gap leads. These coils will be better if they are would as bi-filar serially-connected coils. The reason for this arrangement is that the magnetic field component of the coils is (nearly) zero as the current flowing through the wire is flowing in opposite directions in alternate turns, and so the magnetic fields produced should cancel out:

Tesla was granted US Patent 685, 957 "Apparatus for the Utilisation of Radiant Energy" in which he shows various ways of handling the energy collected by the metal plate. It is likely that the pick-up techniques shown in the patent of Hermann Plauston, which is in the Appendix, would also work very effectively with this collected energy. Old patents sometimes mention a "condenser" which is the original term for what is nowadays called a "capacitor".

After careful consideration and many experiments, Tesla concluded that the radiant rays which he was utilising, radiated out so rapidly that electrons were unable to keep up with them. The rays were being carried via a medium consisting of extremely mobile, almost mass-less particles, very much smaller than electrons and which, because of their size and speed, could pass easily through most materials. In spite of their small size, their extreme speed caused them to have considerable momentum. A fact which is **very** difficult to come to terms with is that these rays seem to propagate outwards instantly, with no time delay at all, as if transmitted through matter which is wholly incompressible. It is sometimes called "Radiant Energy" or "RE" for short and appears to have no net charge in conventional terms. This is a unique feature of the universe, with unique characteristics, which if utilised, provides a whole host of new applications and capabilities.

Tesla considered that this newly discovered field acted like a fluid. A hundred and fifteen years later, the cover story of the December 2005 edition of the 'Scientific American' journal states that experimental models hint that space-time could be a kind of fluid. It has taken a long time for modern science to start catching up with Tesla. In actual fact, it was Michael Faraday (1781 - 1867) who came up with the idea in the first place.

The Alberto Molina-Martinez Generator.

US patent application US 20020125774 of 6th March 2002, shows a self-powered electrical generator. Like that used by Bob Boyce, this is a toroidal (ring-shaped) frame with several windings on it, as shown in the diagram below. Once it has been powered up with AC mains frequency voltage, it produces so much power that it can supply it's own input power requirement as well as powering other loads such as light bulbs. This patent application is shown in full in the Appendix.

It is said that the Toroid device built by Stephen Mark and shown in web videos, is a replication of this generator design. The forum at present at <http://www.overunity.com/index.php/topic,2535.0.html> is dedicated to replicating Stephen Mark's device and considerable progress has been made. This group is operating on the basis that instead of a metallic toroid core as shown here, that a Mobius-loop toroidal wire core is used. At this point in time, their efforts have not yet produced a circuit which exhibits a COP>1 performance

You will notice that very many different devices, aimed at doing different things, all operate by generating very sharp DC pulses

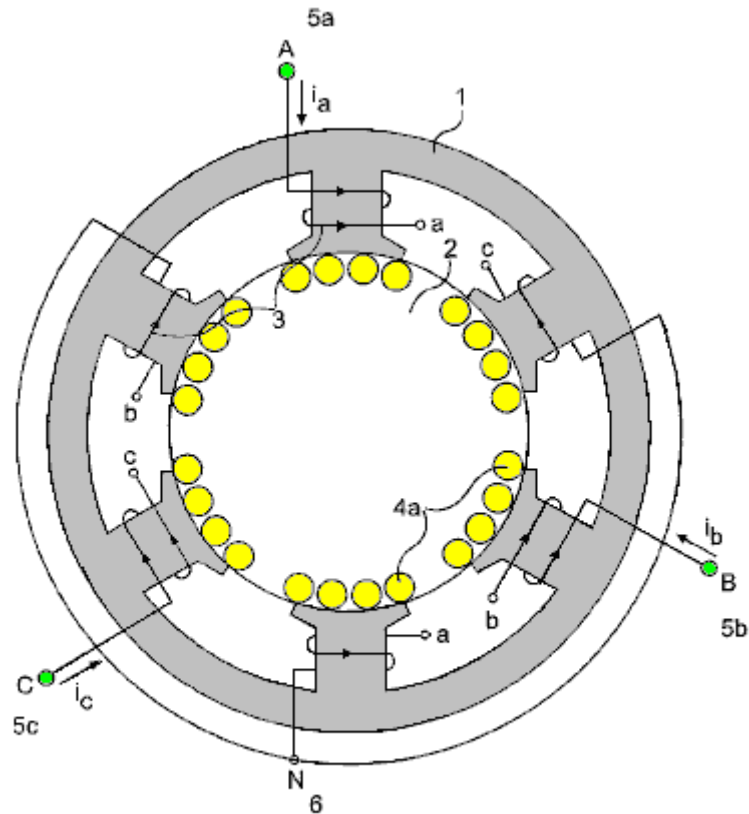

So, a wide range of different devices have the same background technique for making them work. Meyer used the pulsing for water-splitting in a hydroxy gas cell. Bedini uses the pulsing to charge batteries with cold electricity. Tesla used the pulsing to charge batteries, provide heating, cooling and lighting. Boyce uses pulsing to obtain electrolysis at 1,200% of Faraday's stated maximum rate of electrolysis. Gray used the pulsing to capture cold electricity to drive a powerful electric motor. Many different applications all based on using very short, very sharp, high-voltage pulses.



Alfred Hubbard's Self-Powered Generator.

At Portage Bay on Lake Union, Seattle, Washington in America, Alfred Hubbard, an acquaintance of Nikola Tesla, demonstrated in 1919 a self-powered electricity generator design. The generator was about 14 inches (350 mm) tall and 11 inches (280 mm) in diameter. It powered a 35 H.P. electric motor, which pushed an 18-foot boat which contained no batteries, continuously around the bay for several hours. This demonstration was witnessed by thousands and ended because the wiring was beginning to overheat. It was said that the cable used contained seven strands of 0.09-inch (2.286 mm) diameter. Each of those strands would be able to carry 12 amps and so if this is correct, the cable had a current-carrying capacity of about 84 amps. The diameter of the wire including the insulation was said to be 0.34 inches (8.5 mm). The inner core was said to be made of a pipe containing 16 iron rods with 43 turns of wire around it, which if correct, would suggest 43 turns in 14 inches or 3 turns per inch, implying a cylindrical coil with the turns side by side, touching each other.

However, a great deal of misleading information, not to mention a good deal of speculation has been spread around concerning the Hubbard design, which Alfred took three years to develop. Several years after the demonstration, when Hubbard was employed by the Radium Company, he said that radium was used in the device, which is something which I personally, find very hard to believe, and strongly suspect that Hubbard was persuaded to say that by his employers who were selling radium at that time.

Hubbard made a sketch of one of his smaller generators which was used for ordinary household electrical appliances and that showed a very simple design which had eight cylindrical primary coils each of which was wound on a solid iron bar and connected in series. These primary coils surrounded a slightly larger secondary coil of some 35 turns wound around a hollow tube filled with metal bars or wires (presumably of soft iron). This smaller device was about six inches (150 mm) tall and about five inches (125 mm) in diameter. Each core had only one layer of thick insulated wire and not many turns were used.

I understand that when a patent was applied for, the patent application was seized and a spurious "Of National Security Importance" order slapped on it, acting as an unlawful gag order on Hubbard, prohibiting him from ever developing, using, showing or selling it or anything akin to it. The US Patent Office is a privately owned commercial company, and while they will probably be using the design themselves, they certainly have no intention of ever allowing the public to have access to it as energy freedom is a major step towards complete freedom. Consequently, we know next to nothing about Hubbard's successful design.

The general arrangement was something vaguely like this:

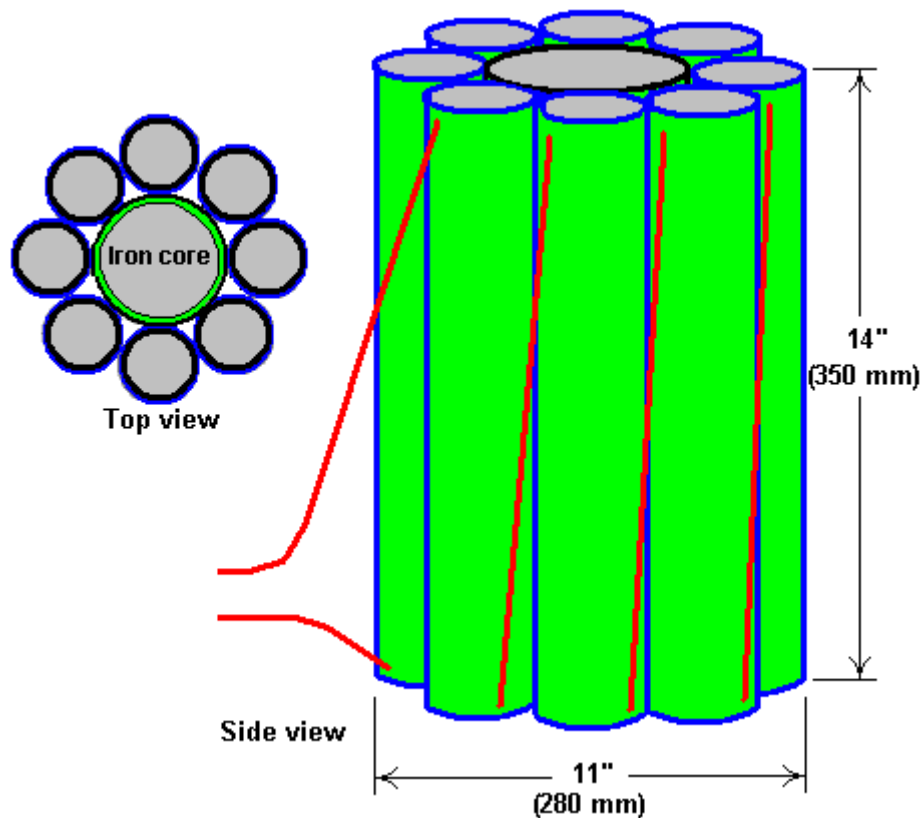

In Joseph Cater's book "The Awesome Life Force" he attempts to explain the theory of its operation, but it must be clearly understood that what Cater says is just speculation on his part as Hubbard's actual design was never disclosed publicly.

What Cater says is certainly plausible, and even if it is not Hubbard's design, it is worth investigating and experimenting with. The mechanism put forward by Cater is based on the well-known and widely accepted graph of the magnetisation of soft iron versus applied levels of magnetic force. This graph is highly non-linear and the central section of the graph rises steeply, indicating that there is a considerable increase in the magnetisation of the iron for relatively little increase in energy input.

Cater stresses that the input waveform should be pulsating DC. The method of applying pulsing DC is then, almost the same as for the Clemente Figuera design shown in chapter 3, with an offset base level of DC current flow which needs to be maintained at all times.

Here is the magnetisation graph for soft iron:

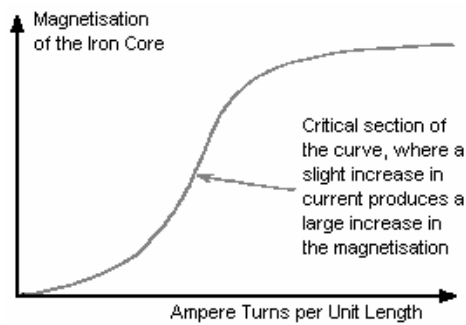
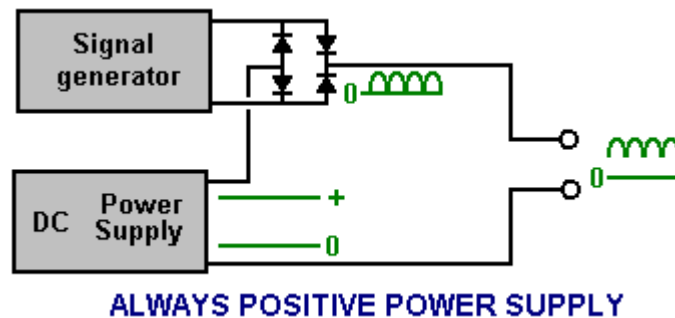

Fig. 29

Fig. 29 shows a graph of the magnetisation of an iron core plotted against ampere turns per unit length. The term “ampere turns” is the number of turns of the coil per unit length of the coil multiplied by the number of amps of current flowing through the coil.

The steep section of the curve appears to start at around 3.5 Tesla, and so, a constant DC current in the magnetising (Hubbard primary) coil needs to provide that level of magnetisation at all times, and the applied pulsing DC half-sinewave waveform applied on top of that and since the induced EMF in a coil is directly proportional to the rate of change of magnetic flux, it follows that the higher the frequency of this sine wave supply, the better. Using a ramp waveform might well be more effective.

Normal working transformers have ampere-turns which are well below this critical point. The additional EMF induced in the coils by the magnetisation of the iron offsets the natural inductive impedance of the coils. This is why transformers have such a high degree of efficiency. If any material other than iron or special steel were used for the core, the efficiency would drop significantly. Hubbard used part of the output power to provide the input power, and so he only needed to provide input power for less than a second to get the device running. The power supply might well be of this nature:



Here, instead of letting the high frequency rectified sine wave (or ramp generator signal) reach zero volts, and additional DC current supply is maintained, and while the signal generator pulses add to the overall voltage applied to the device, the voltage is never allowed to reach zero.

There is possibly another factor which could contribute to the success of the Hubbard device. At that time, the only insulated wire available had thick and heavy insulation. This means that adjacent turns of wire in the coil were separated by a distance equal to twice the thickness of the insulation. Consequently, the gap resulted in a cancellation of magnetic effects produced by electrons flowing in the wire. Since inertia is dependent on the ability to generate a magnetic field, the inertial properties of the electrons would be almost nullified.

There is an optimum distance between the wires which would produce the maximum effect. It seems likely that the thick insulation on Hubbard’s wire produced this optimum distance. Most of the resultant magnetic field was that which encircled both wires and that would be the weaker part of the field. This means that a relatively low EMF could accelerate a larger number of electrons to a high velocity during a very short period of time. As the electrons leave the coil, inertia returns. This would result in a backup of a high concentration of electrons in the coil. Since electrostatic repulsion is not affected, electrons would be ejected from the coil at a high velocity despite their increased inertia. This would produce an output of both high voltage and high amperage.

Joseph Cater's Version of the Hubbard Generator.

Although containing conflicting information, there is what appears to be an implementation of the Hubbard coil system, or perhaps a very closely related device from Joseph H. Cater. As usual, information on it is limited and not particularly clear, so the following is just my attempt to piece together some information from different sources. Much of this information comes from a document which has Geoff Egel's name on it and although it seems likely that Geoff is quoting some other source, my thanks goes to him for sharing what we have here. The diagrams give the names of various minor websites none of which exist any longer and so these have been removed as they have no useful purpose any longer. Here is an original diagram from this information:

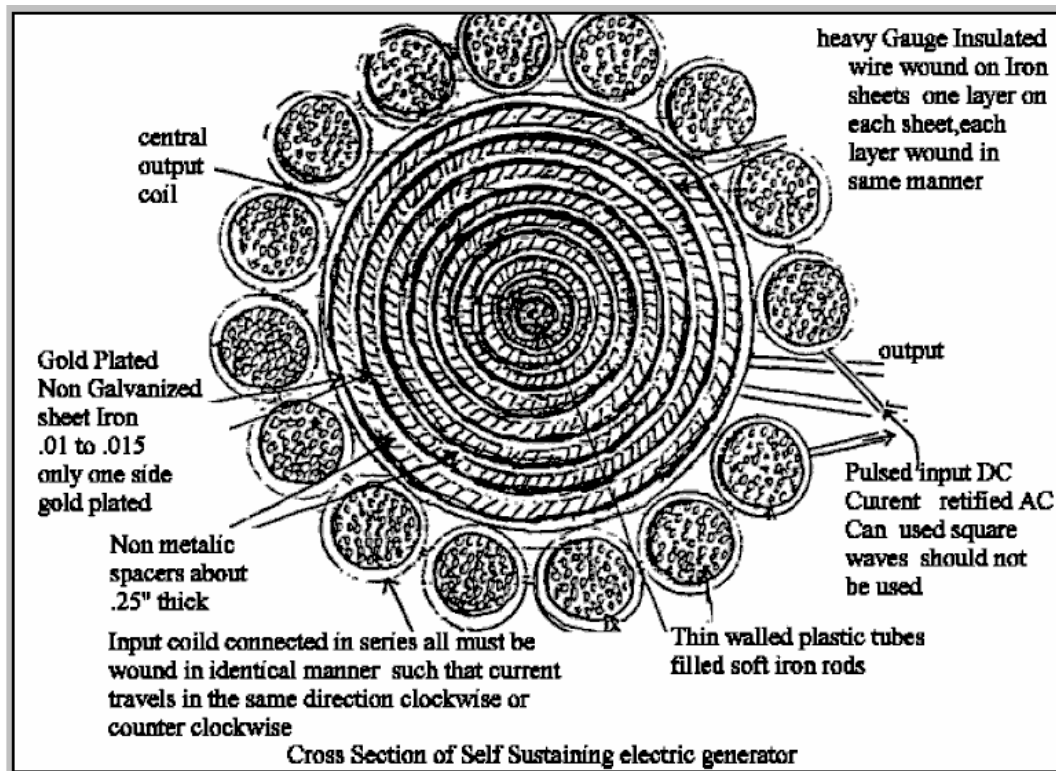

As it seems to me that there are many conflicting details in this information, I am presenting it here in pretty much the same form in which it reached me. You will notice that the composite central coil is now presented as the secondary rather than the primary. It should be stressed that Hubbard never disclosed his design publicly and so this, and similar information elsewhere, has to be considered to be guesswork.

Mr. Cater claims that a group in California built this device which, it is claimed, performed very well, but he does not claim that he has personally seen or tested such a device. This design is published for researchers and experimenters in order that a working prototype may be developed. Mr. Cater says "I would be willing to give big odds that if my instructions are carried out to the letter, then sensational results will be obtained. It should easily outperform any other generator that has ever been built including the Moray and the Hubbard devices. It could easily be mass-produced.

Some years ago I got word from someone in Germany who built a similar configuration (a very poor replica of this one, where the output coil consisted of only windings on a solid iron bar which in turn was surrounded by smaller coils on smaller bars which constituted the input. Even this was quite successful as the output was three times the input. I do not know what happened to the builder but such a crude device as this could give the world free energy. The output of a small unit could be used as the input for a larger one and so on".

Please bear in mind that these plans are not meant to be explicit in every fine detail, but are provided as the best guide that the author can make with the available data. Therefore you will need to use some of your own ingenuity and design skills in the construction of this rather unusual coil configuration.

The Primary Coil Input-driver: Suggestions for the Bench-test Prototype

I would suggest the construction of an input power supply which can vary Frequency, Voltage and Current. A frequency range of 50 Hz to 1,000 Hz would be a good starting point. The higher the frequency of the input current (the amperage and voltage being held constant) the greater the induced output E.M.F. as it is directly proportional to the frequency (the rate of change of the magnetic flux). A frequency of 50 or 60 Hz would be

more convenient to experiment with as these frequencies are standard power mains frequencies, however a frequency of 360 Hz or higher is recommended.

Mr. Cater suggests that for experimental purposes in determining the input needed to get the desired output, that rectified 12 volt AC is used. Sinusoidal waves should be used and not square waves. Because of its tremendous potential, care should be taken to limit the amount of input current. One should start with a low frequency (50 or 60 Hz) and low amperage, then gradually increasing the current until the desired input / output is obtained.

Such caution was not followed with a previous model built by a group in California and it resulted in the disintegration of the output coil. The iron sheets in this model were not plated and did not have the caps fitted. Nevertheless, it was still an effective orgone accumulator. The gold plating of the iron sheets and the addition of the caps enables it to operate with a much lower input current and lower frequency.

The Primary Coils

If the outer body of your secondary coil is eight inches in diameter, then you won't fit the recommended seventeen primary coils around its perimeter. If your primary coils are one and a half inches in diameter then these will fit nicely around the perimeter of an 8-inch diameter secondary coil. However, it is preferable to have larger primary coils as mentioned in Mr Cater's opening comments, so it may be advisable to stick to the recommended 2-inch diameter size for the primary coils, but settle for one less and use only 16 primary coils.

Experimentation will decide which is the best way to go. For the purposes of this article I will refer to 2-inch diameter coils.

Cut medium gauge soft iron rods (oxy-welding rods will do) to 13-inch lengths. Be sure to de-burr the cut rods so that a compact fit is achieved.

Next, wind each coil separately with one terminal at each end (no gap 'G' is required for the primary coils). Then the primary coils are physically mounted around the large secondary coil - refer to Diagram 1.

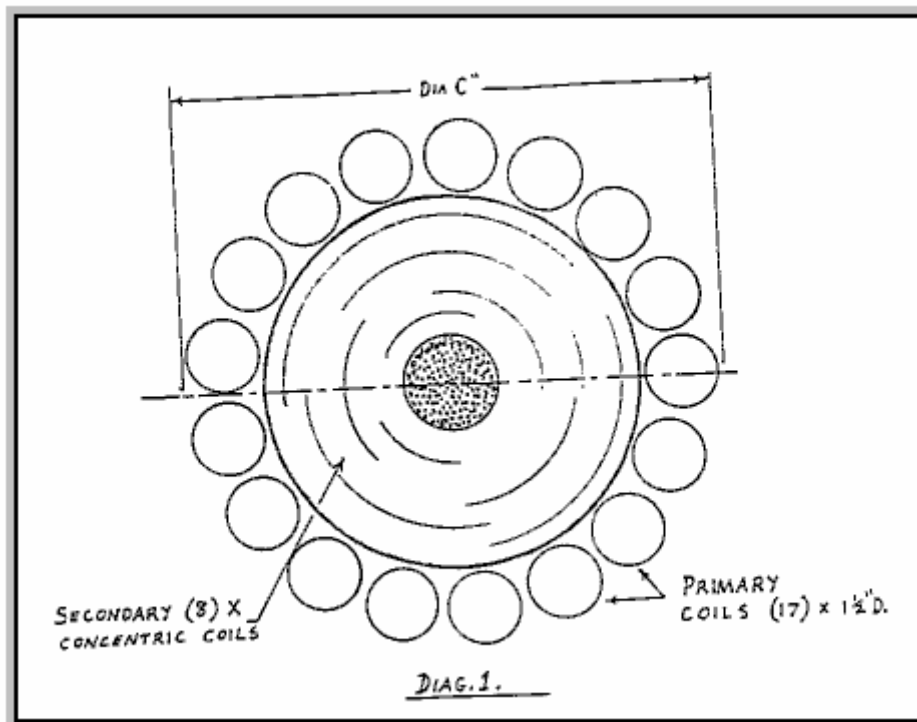

The primary coils are then interconnected with suitable leads of the same gauge as the coil wire to form a series coil configuration. Refer to Diagram 2.

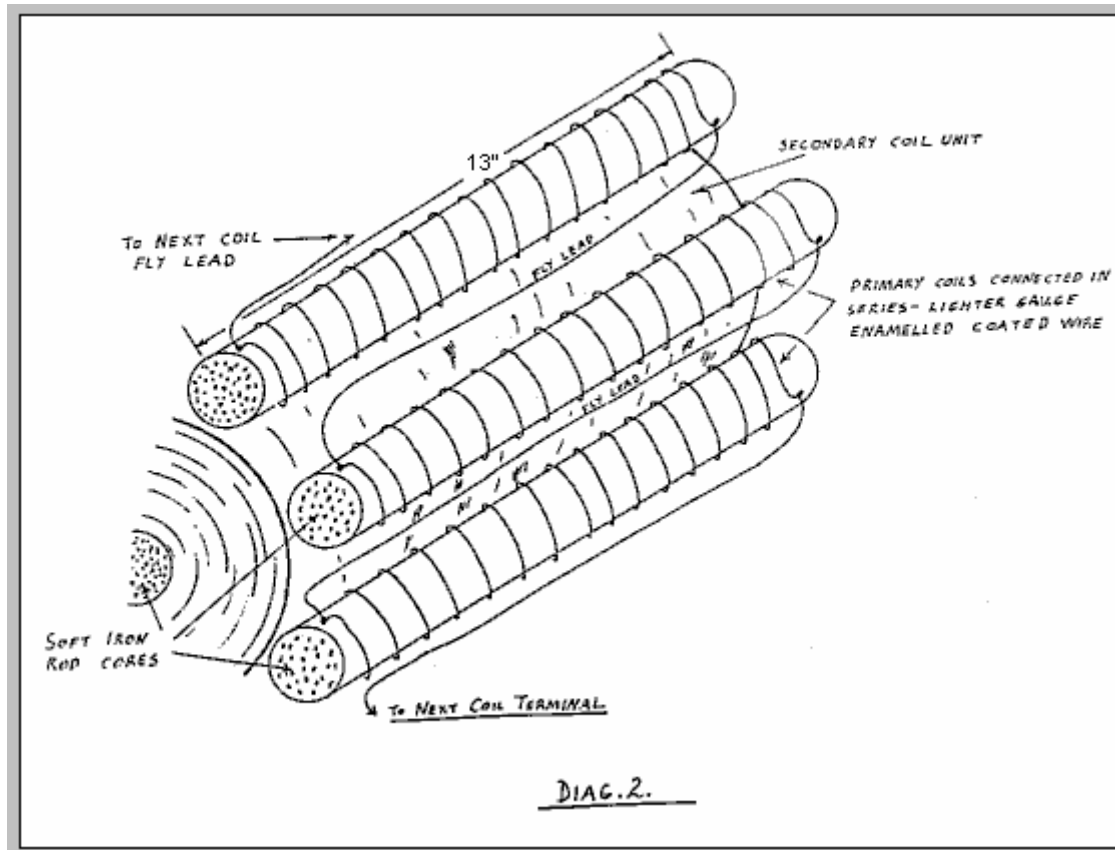

All coils must be wound in an identical manner so that the current in each one travels in a clockwise or counter clockwise direction. It is essential that the current flows in the same direction.

The Secondary Coil: Construction Notes

The secondary coil consists of a number of concentric cylinders and coils of three varying types repeated in a special sequence as detailed here.

1. You begin with the soft iron core in the same way as the primary iron cores were constructed. Use two inch diameter (2" OD) thin-walled PVC tubing cut to thirteen inches (13") in length, and packed with soft iron rods (oxyacetylene welding rods will do).
2. Around the central PVC tubing wrap the gold-plated iron sheeting so that the gold is facing outwards. The iron sheeting needs to be in the range 0.010" to 0.015" in thickness. The iron sheeting should be as thin as possible as you want to get the most powerful fluctuating magnetic field possible, induced as close to the wire as can be physically and electrically achieved.

This is the reason for the oil-soaked iron powder. The purpose of the oil is, of course, to make the iron powder physically manageable. The thinner the iron sheeting the more completely magnetised it will be. The gold plating is only the frosting on the cake so to speak. It certainly does not need to be very thick and no, you don't have to pay thousands of dollars for gold plating. A simple chemical process is used. Ask your local electroplater for a lead in the right direction. As to the suppliers of the iron sheeting, you certainly wont find it down at your local hardware store as it is a rather a specialised item. Try transformer manufacturers or electric motor and generator suppliers.

You will need eight (8) concentric iron cylinders. Each one will be thirteen inches (13") wide with varying lengths depending on the circumference of each concentric layer. Allow a quarter inch over the circumference length to give a small overlap. You will need to devise a method for keeping the iron sheeting in position ready for the next stage of construction. Several spots of super glue should do the job nicely.

3. Now that you have wrapped your first iron layer around the central PVC tube containing the soft iron core, you are now ready to wind your first secondary coil. Use a heavy gauge enamel coated wire somewhere near the gauge of house wiring. If this is not available, then insulated single core wire will do. As with all the coils that are to be wound, whether primary or secondary, only one layer of wire is wound. When you are winding the secondary coil leave a small space between each turn. Refer to Diagram 3.

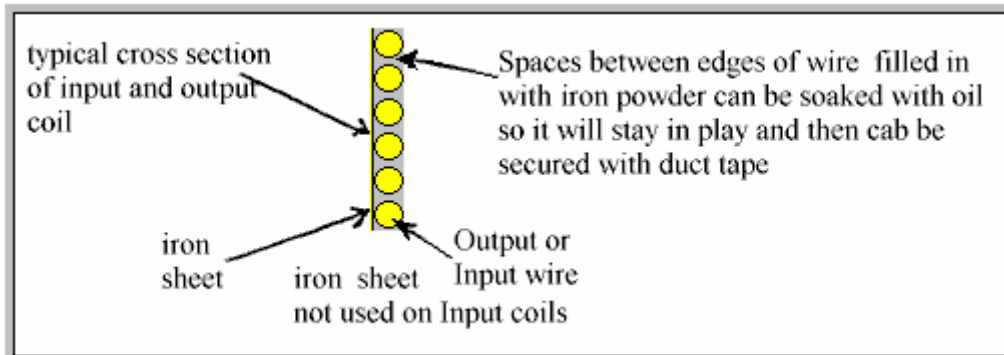

The gap 'G' reduces the inertia of flowing electrons as well as providing room for the oil-soaked iron powder which is to be packed between each winding. Perhaps 1 mm to 1.5 mm would be a sufficient gap between adjacent turns of the winding. However, before packing each coil with the iron powder, it would be advisable to lacquer the coil winding to seal it in position on the iron sheeting. This also provides extra insulative protection. The purpose of the non-metallic concentric spacers within the secondary coil serves two purposes:

- a. To minimise the cancellation effects.
- b. To produce an Orgone accumulator effect.

The material used could be heavy-duty PVC tubing with quarter-inch thick walls or quarter-inch thick sheeting, possibly heat treated, wrapped around the coils. You may be lucky for one or two of the concentric rings required, and have a piece of PVC tubing which is just the right diameter. For the remaining diameters you could reduce the circumference of a larger piece of tubing, thus converting it to the desired diameter. Be sure that the butt joint is perfect or that any gaps in the join are filled in with a suitable plastic filler. Some innovation and ingenuity may be required for this part of the construction. The general strategy for building this multi-layered secondary coil is to build it by winding each coil on separate concentric cylinders consisting of the gold-plated iron sheeting wrapped around the non-metallic spacer. The inner diameter of one cylinder will be the outer diameter of another. They are then joined together one inside the other. Fly wires are then used to interconnect the ends of each coil. For initial experiments this may be done in several ways, two of which are recommended by Mr. Cater:

1. Each concentric coil may be connected in series so that the current will flow in the same direction, either clockwise or counter clock wise as if it is one continuous coil.
- or
2. Each adjacent pair of coils is wired so that the current flows in the opposite direction to the adjacent pair of coils. In other words, the first two adjacent coils are connected in the clockwise direction, and then the next pair of adjacent coils is connected counter clock wise. The third pair will be clockwise and the fourth pair counter clockwise. Changing the wiring configuration can be achieved quite simply by rearranging the external fly leads which are used to interconnect each of the secondary coils.

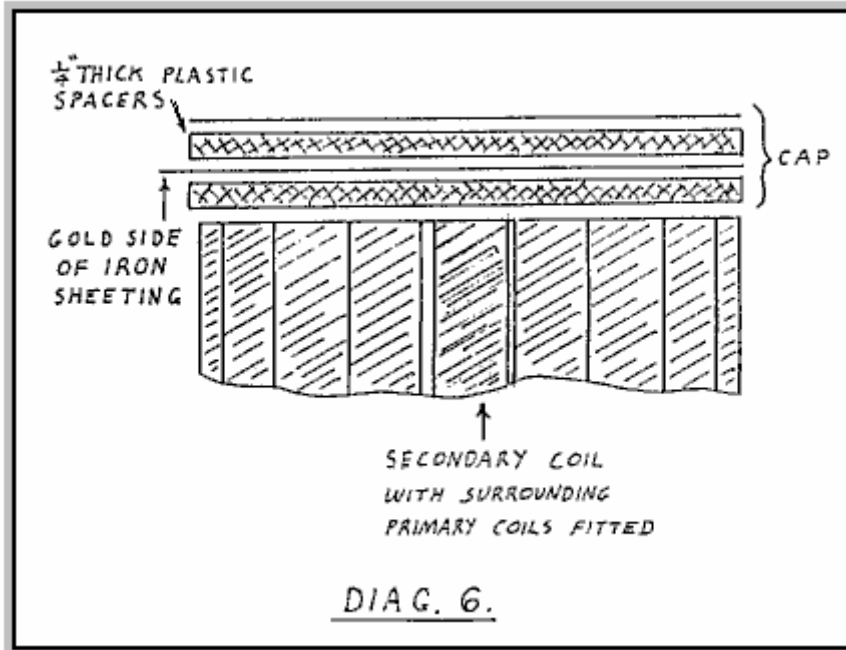

The leads should take the shortest path around the outer face of the secondary coil and of course they should be of the same gauge as the actual coil winding itself. Refer to Diagram 4

The Side Caps

Now that you have completed the secondary coil and wound the primary coils, the next step is to cut the caps to their correct size so that their diameter will be big enough to cover in the entire primary and secondary coil assembly. Refer to Diagram 1 above where the required dimension is marked as "Dia. C"

1. Cut eight pieces of quarter-inch thick plastic sheeting to the diameter "Dia. C" dimension, 4 per cap, so 8 in total.
2. Cut eight pieces of gold-plated iron sheeting in the same manner.
3. Glue together the plastic and iron sheeting as illustrated in the expanded drawing Diagram 6.

Devise a method to attach the caps to the sides of the unit and a means of positioning the outer primary coils so that they are all held in their correct positions. Bear in mind that powerful magnetic forces will be present and that the unit itself will be quite heavy, so a strong form construction is needed. One suggestion is to use dowels to hold the caps in position and use suitably shaped plastic spacers to position and hold the primary coils in place. Once the caps have been fitted, the generator becomes a highly potent orgone accumulator.

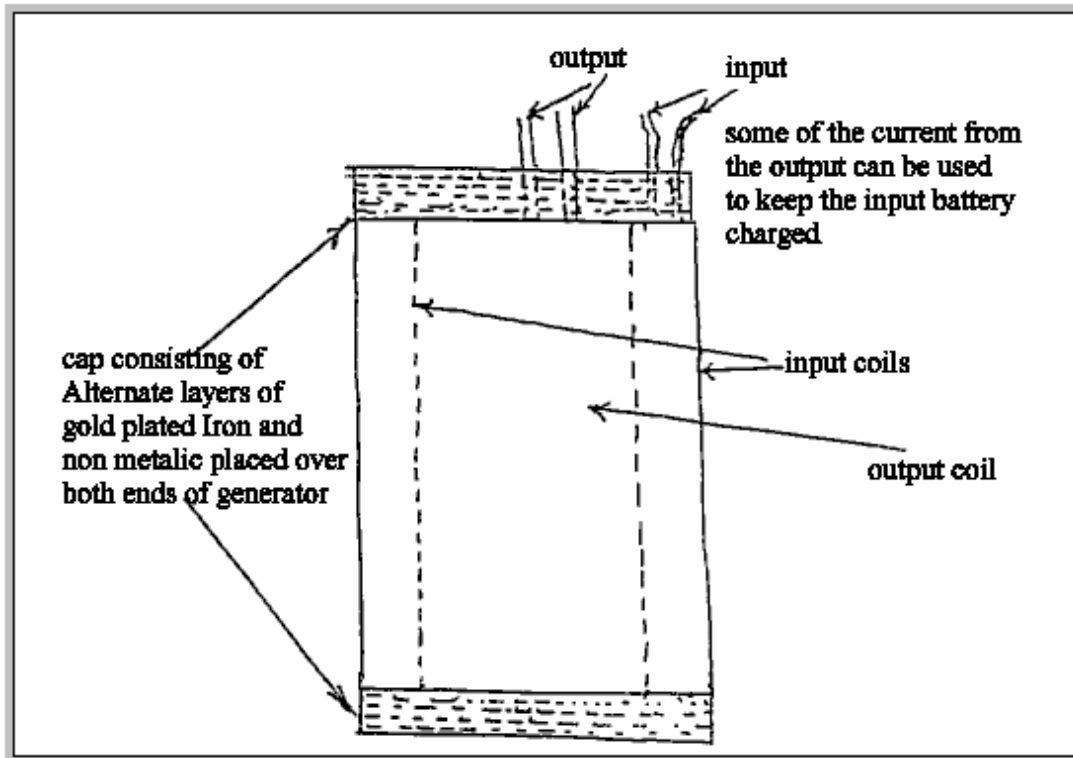

Gold-plated iron is many, many times more effective than any other metallic material. The accumulator effect greatly increases the effectiveness of the generator.

Testing

Now that you have actually completed all the construction work, you now need a suitable input driver unit which should have been thoroughly tested and ready for driving the unit. Let's be optimistic and hook up a good size load for the secondary, a couple of radiator bars (electric heaters) should do to begin with. Across the output terminals you can connect all the usual test gear.

Summary

The construction of the secondary coils may be carried out by completing the following steps:

1. Fill a thin-walled PVC tube of 2-inch diameter and 13-inches long, with soft iron rods.
2. Wrap the PVC tubing with the iron sheeting cut to 13" size with a 1/4" overlap along the tube, flush with the ends. Ensure that the **gold side** is facing outwards.
3. Wind the single-layer heavy-gauge coil with a suitable spacing between each turn of the winding and attach suitable terminals at each end of the wire.
4. Coat the coil winding with lacquer, sealing it in position.
5. Pack between each turn of the coil windings with oil-impregnated iron powder.
6. Wrap the coil and iron powder with ducting tape.
7. Fit the quarter-inch thick non-conductive spacer as described above.
8. Repeat step 2 to step 7, eight times and finish off by fitting an outer casing of the quarter-inch thick non-conducting material.

This Article first saw the light of day several years ago and it is believed, was first published in the Australian Free-Energy Newsletter called "Tuning In".

Another source comments on the Cater device as follows:

A self-sustaining electric generator was demonstrated at Seattle, Washington in 1919 by an inventor named Hubbard. His invention was supposedly 14 inches long and 11 inches in diameter. It powered a 35 horsepower electric motor which pushed a boat continuously around the bay for several hours. This demonstration was witnessed by thousands. During the time of his demonstrations, Hubbard made a sketch of one of his smaller generators used to power ordinary electrical appliances shown in Fig. 28:

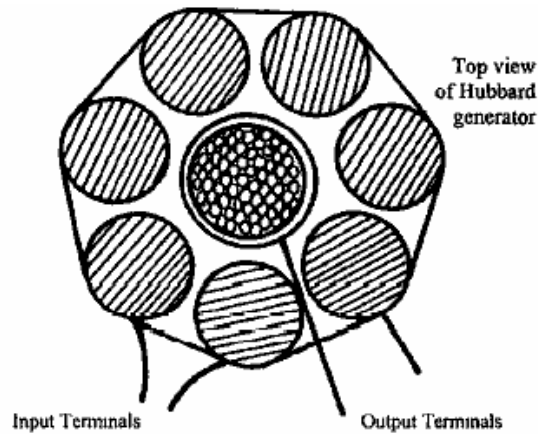

Fig. 28

It was approximately six inches long and about five inches in diameter. It consisted of eight coils in series, wound on iron cores which in turn surrounded a slightly larger central coil. The central coil was wound on a hollow tube which contained many small rods of soft iron. Four terminals extended from the unit, two connecting to the outer coils which received the input current, while the other two came from the central coil.

It is highly significant that both wires used in the generator appeared to be of heavy gauge like those used in power lines with the same kind of insulation. Each coil had only one layer of this wire which means that only a moderate number of turns were used in the entire generator. It is known that the generator produced a fluctuating current of an undisclosed frequency and had no moving parts.

The basic principle on which the generator operated is apparent. A small current passed through a coil with a moderate number of turns per unit length will magnetise an iron core to a surprising degree. This principle is utilised to great advantage in electromagnets. What apparently hasn't been realised is that during the brief interval in which the current builds up after it is turned on, an induced EMF (voltage) is produced in the coil by the changing magnetic flux, which is in the same direction as the current. This induced EMF is the result of the magnetic field produced by the magnetisation of the iron core. If this induced EMF were in the opposite direction to the current, then a sizeable current could never be produced in the coil as the EMF opposing the current would automatically cancel it before it could increase.

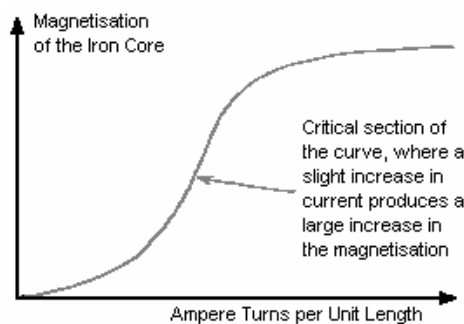

Fig. 29

Fig. 29 shows a graph of the magnetisation of an iron core plotted against ampere turns per unit length. The term "ampere turns" is the number of turns of the coil per unit length multiplied by the number of amps of current flowing through the coil. For example, a current of 1 amp flowing through a coil of 100 turns will produce the same effect as 2 amps flowing through a coil of the same length which has only 50 turns.

There is a section on the curve where a slight increase in ampere turns will produce a tremendous increase in magnetisation of the iron core. The cause of this phenomenon should be analysed. It seems strange that just a few ampere-turns can produce extensive and significant magnetisation of the iron core. Yet, the observable magnetic field produced by the current without the magnetic core is tiny by comparison. A similar field produced by a permanent magnet, would be unable to induce a noticeable magnetisation of the iron. This is something which conventional science has found convenient to ignore.

If an alternating current is passed through an electromagnet and the ampere-turns exceed a critical point, a chain reaction takes place in the coil, producing a tremendous increase of current in the coil. This is responsible for transformers which occasionally burn out during current surges. In some cases the sudden increase in current is sufficient to push the ampere-turns value into this critical range. The chain reaction results from an increase in the magnetisation of the iron which produces an increase in the current, which then produces an additional large increase in magnetisation, and so on until the iron reaches its maximum degree of magnetisation.

This process occurs during the first half of the AC cycle. The EMF is flowing in the direction opposite to that of the current after it reaches its maximum value and the second part of the cycle begins. This EMF, which is the same magnitude as that which brought the current to its maximum value during the first part of the cycle, now acts as a brake and stops the current. The applied alternating EMF then starts the current in the opposite direction and the identical process occurs again with the current flowing in the opposite direction.

Normal working transformers have ampere-turns which are well below this critical point. The additional EMF induced in the coils by the magnetisation of the iron offsets the natural inductive impedance of the coils. This is why transformers have such a high degree of efficiency. If any material other than iron or special steel were used for the core, the efficiency would drop significantly.

A normal square-wave pulsed current cannot be used in such a device due to the very short time of the rise and fall of the applied voltage, so a sine wave power supply is needed to produce this effect. Since the induced EMF in a coil is directly proportional to the rate of change of magnetic flux, it follows that the higher the frequency of this sine wave supply, the better.

There is possibly another factor which could contribute to the success of the Hubbard device. At that time, the only insulated wire available had thick and heavy insulation. This means that adjacent turns of wire in the coil were separated by a distance equal to twice the thickness of the insulation. Consequently, the gap resulted in a cancellation of magnetic effects produced by electrons flowing in the wire. Since inertia is dependent on the ability to generate a magnetic field, the inertial properties of the electrons would be almost nullified.

Floyd Sweet's "VTA" Self-Powered Generator.

Another device in this category of pulsed devices which tap external energy was produced by Floyd ("Sparky") Sweet. The device was called "Vacuum Triode Amplifier" or "VTA" by Tom Bearden. There is very little practical information available on this device, though there is a video of it in operation on the web, with an input power of just 0.31 milliwatt and a continuous power output of more than 500 watts (112 volts AC at 60 Hz) which is a COP of more than 1,612,000 which is spectacularly impressive.



The device was capable of producing more than 1 kW of output power at 120 Volts, 60 Hz and can be connected so as to be self-powered. The output is energy which resembles electricity in that it powers motors, lamps, etc. but as the power increases through any load there is a temperature drop instead of the expected temperature rise, which is why it is called "cold" electricity.

When it became known that he had produced the device he became the target of serious threats, some of which were delivered face-to-face in broad daylight. It is quite possible that the concern was due to the device tapping zero-point energy, which when done at high currents opens a whole new can of worms. One of the observed characteristics of the device was that when the current was increased, the measured weight of the apparatus reduced by about a pound. While this is hardly new, it suggests that space/time was being warped. The German scientists at the end of WWII had been experimenting with this (and killing off the unfortunate people who were used to test the system) - if you have considerable perseverance, you can read up on this in Nick Cook's inexpensive book "The Hunt for Zero-Point" ISBN 0099414988.

Floyd found that the weight of his device reduced in proportion to the amount of energy being produced. But he found that if the load was increased enough, a point was suddenly reached where a loud sound like a whirlwind was produced, although there was no movement of the air. The sound was heard by his wife Rose who was in another room of their apartment and by others outside the apartment. Floyd did not increase the load further

(which is just as well as he would probably have received a fatal dose of radiation if he had) and did not repeat the test. In my opinion, this is a potentially dangerous device. It should be noted that a highly lethal 20,000 Volts is used to 'condition' the magnets and the principles of operation are not understood at this time. Also, there is insufficient information to hand to provide realistic advice on practical construction details.

On one occasion, Floyd accidentally short-circuited the output wires. There was a bright flash and the wires became covered with frost. It was noted that when the output load was over 1 kW, the magnets and coils powering the device became colder, reaching a temperature of 20 degrees Fahrenheit below room temperature. On one occasion, Floyd received a shock from the apparatus with the current flowing between the thumb and the small finger of one hand. The result was an injury akin to frostbite, causing him considerable pain for at least two weeks.

Observed characteristics of the device include:

1. The output voltage does not change when the output power is increased from 100W to 1 kW.
2. The device needs a continuous load of at least 25W.
3. The output falls in the early hours of the morning but recovers later on without any intervention.
4. A local earthquake can stop the device operating.
5. The device can be started in self-powered mode by briefly applying 9 Volts to the drive coils.
6. The device can be stopped by momentary interruption of the power to the power coils.
7. Conventional instruments operate normally up to an output of 1 kW but stop working above that output level, with their readings showing zero or some other spurious reading.

It appears that Floyd's device was comprised of one or two large ferrite permanent magnets (grade 8, size 150 mm x 100 mm x 25 mm) with coils wound in three planes mutually at right angles to each other (i.e. in the x, y and z axes). The magnetisation of the ferrite magnets is modified by suddenly applying 20,000 Volts from a bank of capacitors (510 Joules) or more to plates on each side of it while simultaneously driving a 1 Amp 60 Hz (or 50 Hz) alternating current through the energising coil. The alternating current should be at the frequency required for the output. The voltage pulse to the plates should be applied at the instant when the 'A' coil voltage reaches a peak. This needs to be initiated electronically.

It is said that the powering of the plates causes the magnetic material to resonate for a period of about fifteen minutes, and that the applied voltage in the energising coil modifies the positioning of the newly formed poles of the magnet so that it will in future, resonate at that frequency and voltage. It is important that the voltage applied to the energising coil in this 'conditioning' process be a perfect sinewave. Shock, or outside influence can destroy the 'conditioning' but it can be reinstated by repeating the conditioning process. It should be noted that the conditioning process may not be successful at the first attempt but repeating the process on the same magnet is usually successful. Once conditioning is completed, the capacitors are no longer needed. The device then only needs a few milliwatts of 60 Hz applied to the input coil to give up to 1.5 kW at 60 Hz at the output coil. The output coil can then supply the input coil indefinitely.

The conditioning process modifies the magnetisation of the ferrite slab. Before the process the North pole is on one face of the magnet and the South pole on the opposite face. After conditioning, the South pole does not stop at the mid point but extends to the outer edges of the North pole face, extending inwards from the edge by about 6 mm. Also, there is a magnetic 'bubble' created in the middle of the North pole face and the position of this 'bubble' moves when another magnet is brought near it.

The conditioned slab has three coil windings:

1. The 'A' coil is wound first around the outer perimeter, each turn being $150 + 100 + 150 + 100 = 500$ mm long (plus a small amount caused by the thickness of the coil former material). It has about 600 turns of 28 AWG (0.3 mm) wire.
2. The 'B' coil is wound across the 100 mm faces, so one turn is about $100 + 25 + 100 + 25 = 250$ mm (plus a small amount for the former thickness and clearing coil 'A'). It has between 200 and 500 turns of 20 AWG (1 mm) wire.
3. The 'C' coil is wound along the 150 mm face, so one turn is $150 + 25 + 150 + 25 = 350$ mm (plus the former thickness, plus clearance for coil 'A' and coil 'B'). It has between 200 and 500 turns of 20 AWG (1 mm) wire and should match the resistance of coil 'B' as closely as possible.

Coil 'A' is the input coil. Coil 'B' is the output coil. Coil 'C' is used for the conditioning and for the production of gravitational effects.

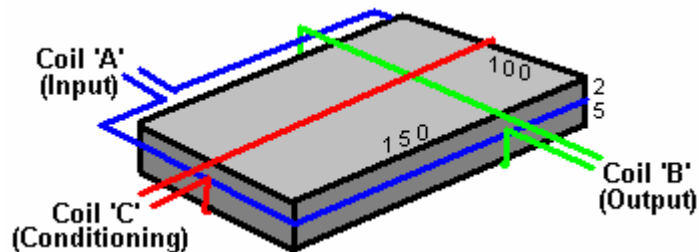

At time of writing, information and photographs of the original device can be found on the website: <http://www.intalek.com/Index/Projects/Research/Construction%20of%20the%20Floyd%20Sweet's%20VTA%20by%20Michael%20Watson.htm> where a paper by Michael Watson gives much practical information. For example, he states that an experimental set up which he made, had:

The 'A' coil with a resistance of 70 ohms and an inductance of 63 mH,
 The 'B' coil, wound with 23 AWG wire with a resistance of 4.95 ohms and an inductance of 1.735 mH, and
 The 'C' coil, also wound with 23 AWG wire, with a resistance of 5.05 ohms and an inductance of 1.78 mH.
 Chapter 3 has additional information on the VTA.

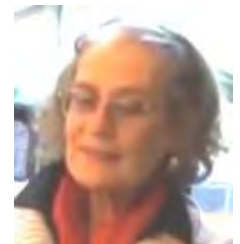

Rosemary Ainslie's COP=17 Heater.

Rosemary Ainslie has produced a pulsed heater system which has been measured at a performance of COP = 17. This is a recent design and as far as I am aware, has not yet been replicated by other people. Panacea-bocaf.org are working with Rosemary's original developers to produce an independent implementation of the heater. At this point in time, the heater has been built to a prototype testing scale for laboratory examination and measurement and not been produced in the kilowatt range, which, hopefully, will come at a later date.

Panacea have produced a 250-page document describing the research, the testing, the theory, etc. and that can be downloaded free using this link:

<http://www.panaceatech.org/Rosemary%20Ainslie%20COP17%20Heater%20Technology.pdf>

As that document contains the details which scientists need to see for serious testing and development, it may be a little technical for some people, so Panacea have produced a simplified version aimed at the average home-build investigator and that can be downloaded free using this link:

http://www.free-energy-info.tuks.nl/Ainslie_heater_circuit.pdf

In very broad outline, the circuit produces the same very short, very sharp voltage pulses that are the basis for so many "free-energy" devices. The circuit used looks very simple but in spite of that, the way that it operates is not at all simple. The circuit is shown below and to a quick glance, it looks like a standard 555 timer chip circuit, used in many existing applications. However, if the circuit is operated as a 555 pulsing circuit, then the output is not COP>1.

Looking more closely, we notice that the link between the output of the 555 chip on pin 3 and the input gate pin of the Field-Effect Transistor, is unusual as it is not the usual voltage divider between pin 3 and the 0-volts ground line. Instead, the gate is directly coupled to the 555 chip output by a single, low-resistance preset resistor.

Normally, an NE555 chip struggles to reach 50,000 cycles per second and a large number of 555 chips on the market can't even operate at even that frequency. To get Rosemary's circuit into it's COP>1 operation, the resistor marked "**GATE**" is adjusted very slowly to find the point at which the circuit becomes unstable, over-rides the normal operation of the 555 chip and starts oscillating at the resonant frequency of the overall circuit, forcing the 555 chip to become a feedback component. The circuit then produces the sharp, short voltages spikes at more than ten times the operating speed of the 555 chip and pulsing the 10-ohm heating element marked "**LOAD**" at about 500,000 pulses per second.

That rate of operation is clearly well outside the possible performance of an NE555 chip, besides which, the timing elements of the chip should be producing a much lower frequency, as indeed it does before the "**GATE**" resistor adjustment causes the circuit to break out of its normal design-mode operation and start the high-speed spike generating, resonant performance. The circuit used is shown here:

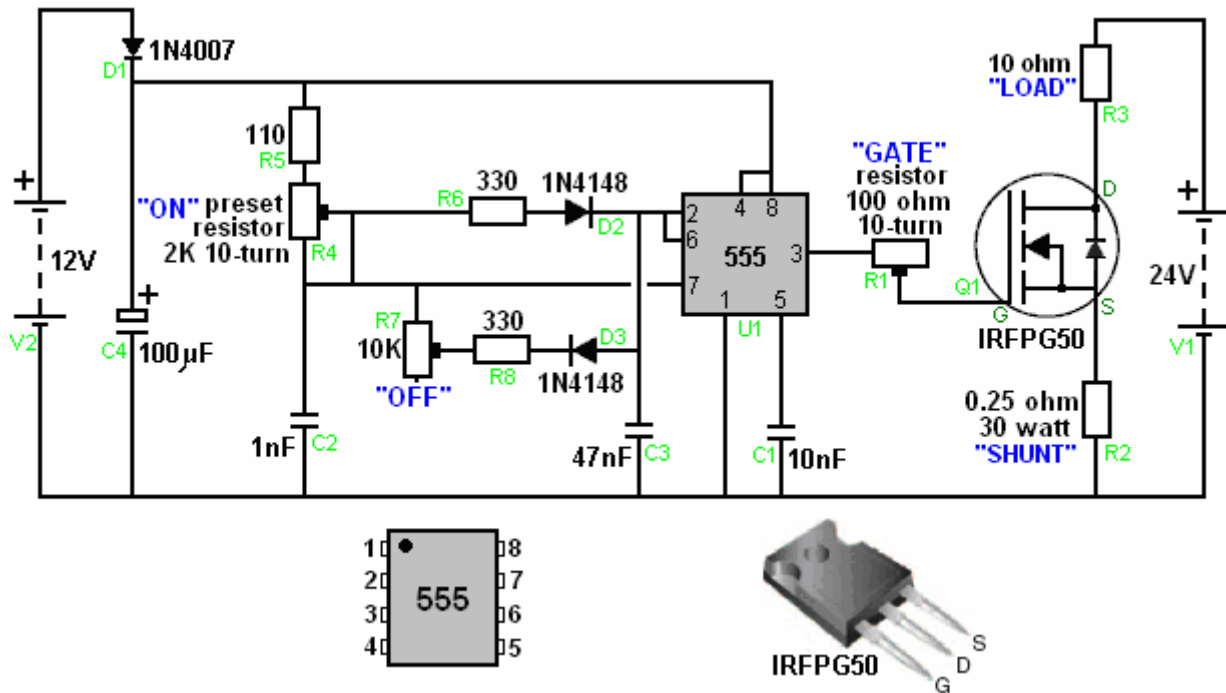

As Panacea-bocaf are working to test and develop this circuit further, it would be a good idea to download their free documentation on the design and keep an eye on their progress in this field. The two documents give very considerable detail on the work which has already been done, and of course, you can yourself experiment with this circuit and see what results and adjustments you can discover yourself.

Joseph H. Cater

Joseph comments: The experiments of Schauburger and others have confirmed the enormous and almost unlimited quantities of electricity housed in water. The following is an absurdly simple and practical method of extracting this energy. It employs the "Coanda" or "cloud-buster" effect.

A plastic tube 14" to 16" (350 mm to 400 mm) long and about 2.5" (65 mm) in diameter is filled with distilled water. At each end, exposed to the water, is a copper terminal which is used for both the electrical input and output. Rechargeable dry cells of suitable voltage are connected in series with the input terminals. When the two output terminals are short-circuited or connected to a load, electricity starts flowing. This is current entrained by the input current. When high voltage is applied, the output voltage is almost as great as the input voltage. However, the amperage is inadequate. The answer to the problem is ultrasonics. It is an experimental fact that ultrasound of 600,000 Hz focussed on a container of water causes the water to boil. This means that sound of this frequency disintegrates large quantities of "soft" electrons in the water. The sudden release of "hard" electrons produces tremendous thermal agitation of the water molecules.

A DC ultrasonic transducer attached to the tube would produce sufficient free electrons to be entrained for the unit to have almost unlimited output potential. The tube functions like a sounding board. Mr Cater has been given powerful evidence that two different individuals who received this information got sensational results from the generator. They had access to such a transducer. They tried to set up in business but the vested interests saw to it that they were put out of business and persuaded to remain silent ever since.

An associate of Mr Cater built a fist-sized siren which generated a frequency of 600 kHz. When focussed on a small container of water, the water boiled. This demonstrated that it could be used instead of a solid-state DC ultrasonic transducer on the water generator. A small DC motor could operate the siren. It would be far more effective as it produces a much more intense sound. The construction is shown here:

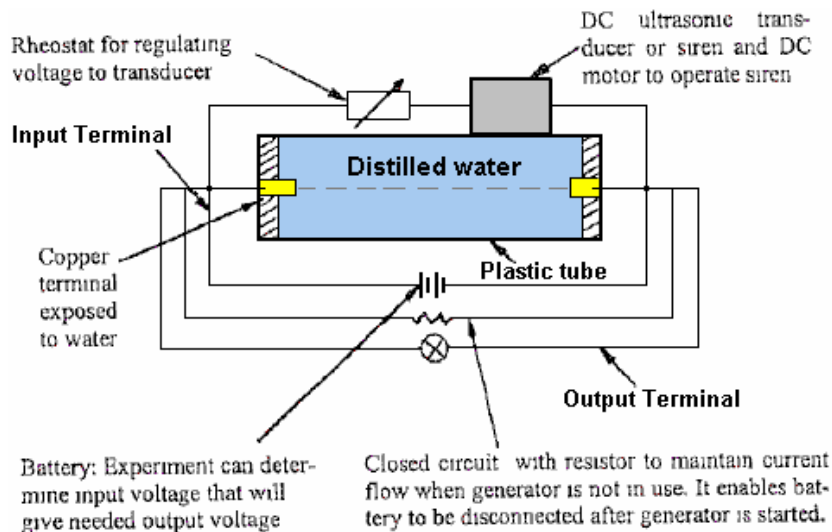

Self-sustaining Electrical Generator Employing the Cloud-buster Effect

Dr Oleg Gritskevitch's 1.5 Megawatt Self-Powered Generator.

Dr Oleg V. Gritskevitch of Vladivostok in Russia, the holder of some seventy patents, designed and fully tested an electrical generator along the same lines as Joseph Cater's device mentioned above. It uses no fuel and has given a DC output of 220 volts at 6,800 amps (1.5 megawatts) for more than two years. As built by Dr Gritskevitch, this is not a home-builder's ideal project as massive electrical input is needed to get the device started, and his prototype weighs 900 kilograms (nearly 2,000 lbs). Details are given on the very good RexResearch web site: <http://www.rexresearch.com/gritskevich/gritskevich.htm> but in broad outline, the device is a toroidal pipe some two metres (6'-6") in diameter, coated on the inside with barium titanate and filled with ultra-pure distilled water mixed with 'heavy water'. Inside the toroid are electromagnetic coils and surrounding it, copper pipes carrying cooling water to keep the temperature down to 50 degrees Centigrade. Also inserted into the toroid at intervals around the circumference are electrical contacts.

The device is started by giving the water a massive high-voltage discharge of some 100,000 volts at 50 mA for three to five minutes. This power input gets the water ionised and circulating. The circulation is maintained by the electromagnetic coils and the power output is around COP=100.



Oleg died without ever getting funding for his design (a typical method of blocking free-energy devices from reaching the market). A more detailed description of the device and its operation comes direct from Oleg:

This is a description of the construction and operation of Oleg V. Gritskevitch's hydro-magnetic dynamo, which is an example of a very powerful new energy system. The prototype in Armenia has averaged some 1,500 kilowatts of power over a period of several years.

Oleg was born on 14 August 1936 and grew up in Vladivostok, Russia. He married and has a son Boris. Gritskevitch was a physicist by education. He worked in the Far-East branch of the USSR Academy of Sciences. Since 1985 he worked independently as an inventor. He has more than 70 patents on inventions ranging from household engineering up to high technologies, which he has been trying to apply in our country although he encountered major difficulties in this. After numerous attempts to obtain the patents, he became convinced that the information had become widely known. Therefore he received the state certificates of know-how (a French way of patenting), for all his inventions.

Introduction

During the 1999 Symposium of the Institute for New Energy, he lectured on his hydro-magnetic dynamo. This paper is his attempt to explain the construction and operation of his dynamo. To protect his secrets from investigators, he, on occasion, provided misleading information. For example, the drawing accompanying the Russian patent mentioned below, shows a cylinder across the toroid to mislead readers. The real dynamo has the toroid alone, without the cylinder. Even its name "hydro-magnetic dynamo" is somewhat deliberately

misleading.

Oleg stated that he had some familiarity with the new energy field. Nearly all purported new energy devices are fairly small electrical generators. The dynamo may be the only new electrical generator which most nearly meets all the requirements of an ideal large-scale electrical generator. Oleg claimed that his dynamo really is the single most valuable invention the world has ever known.

Alexander V. Frolov of St. Petersburg recommended Oleg to contact Dr. Patrick Bailey of the Institute for New Energy since Patrick has lots of contacts who could possibly help with patenting his invention of a new source of energy in USA.

Oleg worked on the theory and creation of the electrostatic generator-converter the "Hydro-Magnetic Dynamo" for about 20 years. The first primitive equipment was created when Oleg worked in the Academy of Sciences. During that time, various changes were introduced in the generator and in the theory of how it works. As a result, it is now ready for manufacture, installation, and applications in industry.

Oleg made the first public report on his work in 1991 at a symposium in Volgodonsk city. His report received positive reactions and reviews from the experts in the nuclear industry in USSR. That same year, he was accepted into the International Nuclear Society. During those years he offered development of this technology to different state bodies and private enterprises. But the answer from everybody was "It is a very interesting and important project, but we cannot fund it.

Eventually, Oleg tried to transfer this technology to the USA through the embassy in Moscow. The former ambassador to the USSR, Dr. J. Matlock knows about it. He wanted to meet Oleg, but at that time there were forces opposed to the carrying out of his plans. So he started to look for other possible investors. He was ready to consider any offers of co-operation, joint patenting, sale of technological information, creation of a joint venture, etc. etc. Oleg was awarded some 70 Russian patents covering a wide range of important technical topics.

History

This project was the result of one article in the August 1972 issue of a popular Russian magazine *Tehnika Molodiozhi*. The article written by A. Kaldamasov was entitled *Ball Lightning in a Liquid*. The article came to the attention of Michail Razovsky and Oleg in 1974. Oleg's group of volunteers and enthusiasts was looking for a new source of energy and so this article served as a starting point for the understanding of chemical-physical processes occurring in water. During the period 1976 to 1978 one year was spent in the radiological lab of the Vladivostok city hospital, including Vladilen Bulgakov, radiology physician, and Michail Razovsky, theoretician in the plasma physics field and others, assembling a device, which was supposed to separate water into oxygen and hydrogen more efficiently. During the experiments, instead of the expected results, it produced electricity very efficiently! The input power during the experiment was one 800-watt water pump. The output was 1,400 watts (COP=1.75). This device was assembled using plastic pipes connected with hoses, where the water was circulating in a loop. This then led to the idea of creating the second device as a generator-toroid.

The second generator was assembled in the workshop of the Ocean Research Institute in Vladivostok (Director Academician Viktor Ilichov), and in the summer of 1990 it was transported to the testing station of the Ministry of Electronics Industry in Vladivostok. This lab was well equipped with all necessary sets of instruments. At the same time, patent papers were filed in the USSR State Committee of Inventions. In the spring of 1991 the State Commission, led by Yurii Lebedev, chairman of the Innovation Council and Chairman of the Russian Federation Council of Ministers, arrived in Vladivostok. This commission arrived to the town for two reasons: to recommend a financial request for manufacturing the dynamo; and to classify this energy source as a "Discovery". (document #14-451).

After the next change in Russian government the financing for the project was terminated. The first article on the dynamo was published in the Russian magazine (*Tehnika Molodyozhi* 1990, #3, March issue, Page 17, entitled "Innovator's Ideas".

Several Armenian physicists, after reading that article, sent Oleg a letter asking to meet with him in Vladivostok for negotiations about the dynamo. They arrived in March 1991 and ran tests on the second generator, which was operational at that time. Oleg flew to Armenia, and work on the third generator started at the end of 1991. It was completed at the end of 1992. It was operating and producing energy until January 1997, when it was destroyed during the war. Some people were also killed and other people moved to the USA. This version of dynamo created an output which averaged 6,800 amperes at 220 volts DC (1.496 megawatts). It's input power was only approximately 1% of the output power.

Oleg was an invited speaker of the Meeting of the Alternative Energy Institute (Dr. Hal Fox) in Salt Lake City in August 1999. The official announcement about his speech had several mistakes (for example, the name of Armenia was changed to Romania).

Dynamo Theory

The **Hydro-Magnetic Dynamo** is a large-scale, emission-free electrical generator, which does not require external fuelling. The dynamo is capable of powering large transportation vehicles such as buses, trucks, ships, locomotives, and aeroplanes. Doubt remains about making dynamos compact enough to power cars.

While three experimental prototypes have been built with Russian and Armenian expertise and equipment, a fourth demonstration prototype needs to be built with more modern Western engineering expertise and equipment to verify the dynamo's performance claims and to further explore the dynamo's potential capabilities.

The claimed performance is as follows:

Dynamos are scaleable from 100 kilowatts to 1,000 megawatts. One 1000-megawatt dynamo is about the size of a two-car garage. For comparison, Hoover Dam's 17 generators have a total capacity of 2,000 megawatts. A dynamo can reliably run continuously for 25 years or more with little or no maintenance, no external fuel source, and no pollution. If a dynamo's output is 1,000,000 watts, its total input power is approximately 10,000 watts and so the dynamo's energy efficiency is about 10,000%.

The source of the dynamo's huge electrical output is a nuclear reaction, which is not generally known to mainstream science. However, it is known that the dynamo produces alpha particles, which are helium nuclei, made from fused deuterium, an isotope of hydrogen with one proton and one neutron. The electrons missing from the helium nuclei are what seem to provide a copious 'sink' of electricity, and that is the secret of the dynamo's ability to generate an exceptionally large amount of electricity. It is also known that the dynamo uses high-density charge clusters. High-density charge clusters are thought by some theorists, to be the basis of plasma-injected transmutation of elements and the neutralisation of radioactive materials. Unlike hot fusion and fission reactors, the dynamo does not accumulate any radioactive components.

The result of the dynamo's processes is conversion of electrostatic fields to direct current. It should be noted that a clear understanding of terms like "Coulomb's conversion" and "liquid Van de Graff generator" is very important.

Schematically, the dynamo is an electrostatic transformer, or in other words an electrostatic voltage multiplier. One version of the dynamo uses lasers to start up. There were three dynamo prototypes built. The first two small experimental prototypes were built in Vladivostok, Russia. The third and last prototype generated electricity continuously, (except when turned off to incorporate improvements), from 1992 to January 1997 in Armenia.

As mentioned above, the Armenian prototype generated a direct current of 6,800 amperes at 220 volts which is about 1.5 megawatts. Minimum power output has been 500,000 watts, and maximum power output has been 2,500,000 watts during winter experiments due to better cooling. The Armenian prototype dynamo's toroid weighed 900 kilograms and had a diameter of approximately 2 meters. Cooling water is circulated through copper pipes wrapped around the toroid. The heat is expelled from the cooling water with a heat exchanger. The working temperature was typically 36 degrees Centigrade.

After a dynamo is assembled, the water is literally 'jump-started' (by discharging a large bank of capacitors) to get it circulating inside the toroid. The starting impulse pressure is as high as 400 atmospheres. The dynamo's controls are temporarily set to generating a modest amount of electricity sufficient to sustain itself, possibly even while being transported from the factory to the place of its future operation. The control circuits are simple as only sensors and a control computer are used. We do not need any technical-maintenance personnel.

For the Armenian prototype dynamo, two 10-Farad capacitor-batteries were used to provide the initial water motion (acceleration and excitation of water). The capacitors were 20 kilograms each, with diameters of 50 centimetres, and were borrowed from Russian military radar stations. Using a total of 20,000 Joules, 100,000 Volts at 0.05 Amperes of current were applied to the Armenian dynamo for 3 to 5 minutes to ionise and polarise the water, which then started the generation of electricity.

The reason for the very high voltage provided by the large Russian radar capacitors, when starting the generator, appears to be to polarise the crystals of barium titanate. One comparison is with the electronic ignition on a gas stove. Once the barium titanate crystals are polarised, the generator is running.

After these capacitors had been used to 'jump-start' the Armenian prototype dynamo, a bank of buffer batteries sustained continuous operation when water motion and ionising began. This battery bank contained 8 powerful 12-volt, 150-ampere lead batteries. The Armenian dynamo's sustaining input power was 14,400 watts. The

nominal maximum output power was about 1,500,000 watts. On one occasion, the output current was accidentally increased to 40,000 amperes for almost a minute. Fortunately, the power was reduced to a safe level before the water started to boil. Internal coils (windings) provide the control of water velocity and therefore control dynamo power. The faster the water is moving, the more electricity the dynamo generates. Once the water stops circulating around the toroid, the dynamo must be 'jump-started' again to a minimum power level before it can sustain its electricity generation using its own output power.

The following is a condensed summary, with some editing and additional commentary, of the "Description" of the dynamo's Russian patent IPC H 02 K 44/00 "*Method of Deriving Electrical Energy and Realisation of Gritskevich's MHD-Generator*":

The dynamo is a sealed polystyrene toroid filled with ultra-pure distilled water with heavy water (deuterium oxide) added. The movement of water inside the closed loop and the use of the unique properties of water as a polar liquid, cause a release of electrical energy as an outcome of a rupture of the hydrogen bonds. Additional electrical energy is drawn from nuclear reactions and micro-cavity processes. The liquid is ionised, polarised, and moving around the toroid at start-up time by a running magnetic field with the help of stimulating electromagnetic windings.

Electrostatic generator-transformer "Hydro-magnetic dynamo". ("GT HMD") works due to the process of amplification and maintenance of a stationary (oscillating in particular) electromagnetic field by hydrodynamic movements of the conductive medium. The stator (i.e. the toroid) is made of materials with a high dielectric permittivity. Liquid rotor is a recombined water ('pure' water with high-molecular compounds), which moves due to the high-voltage discharges and running electromagnetic field.

The main processes in GT HMD are:

- A principle of Van-der-Graff's electrostatic generator, where the solid insulating tape was changed to the liquid one.

- A perpetual washout of the surface electrons from the spacer layer takes place;

- The Coulomb's transformations take place;

- A single-turn low-frequency generator works as a coaxial turn with 4 resonance points and energy carrying substance inside it that has very high resonance properties;

- The electrostatic breakdowns of cavitation-vacuum structures in water take place.

- The polar liquid (pure water) consists of dipoles only, i.e. strictly oriented charged molecules. During the interaction of ionized pure water with the layer BaTiO₃ the electrostatic field of above 10 million volts/cm is formed. During this process the breakdown of physical vacuum takes place.

The electrostatic field, coupled with the action of the BaTiO₃ layer (if we apply electrical field to BaTiO₃, then this layer creates the sound vibrations of about 25,000 Hz, this vibration helps to break down the water molecules) and facilitates the further break down of the molecular-atomic structures of water. Also, due to the perpetual electrostatic discharges, the breakdown of the cavitation-vacuum structures occurs and the cold fusion nuclear reaction continues. With this fusion the energy of 500 kJ/mole is liberated in a vacuum and an energy of 6 kJ/mole is liberated in water. Thus, new hydrogen bonds form in vacuum with the energy liberation of about 20 kJ/ mole. Due to this process the acceleration of ionisation of polar liquid takes place. In addition, the constant 'washing out' of the incomplete electron bindings from the layer of barium titanate occurs and free electrons form. Due to this process, the polar liquid transforms into an ordered flow of electrons and negative ions, which can be described very simply, as an ionic-electric current.

Work on construction of the experimental generator started in September 1991 in Armenia and came to an end in March 1992. The active working weight of the prototype of dynamo (torus + water) was about 900 Kg. The diameter of the torus was about 2 meters. The torus was made from impact-resistant optic polysterol. This torus consisted of two halves, which were turned on the merry-go-round machine.

The monocrystalline barium titanate BaTiO₃ was sprayed on the internal surface of torus, its dielectric permittivity was 6000. The thickness of the layer was about 1 micron. The water was purified to the specific resistance of 18,000,000 Ohm/cm.

As we mentioned above, to start the dynamo two condenser jars of 10 Farad each were used. The energy of a starting battery constituted 20,000 Joules, the voltage was 100,000 Volts and the current was 0.05 Ampere to provide the initial movement of water (acceleration and disturbance).

The electrodes were made of metal tubes with diameter of about 5 mm. The dynamo is started using these electrodes. A total of 32 of these electrodes were installed evenly spaced around the circumference of the toroid.

The toroid's cooling system formed a closed circuit of copper piping with purified water circulated through it. The copper tubes used in this system were covered with glass insulation. They also were the turns of load winding. The temperature of toroid was maintained not higher than 50 Celsius degrees.

An average output power was $220 \text{ volts} \times 6,800 \text{ ampere} = 1,490 \text{ kilowatts}$. The current was DC. Periodically the power could be increased to 2,500 Kw when sufficient cooling of the generator could be provided. The additional power was drawn from four resonant windings. This alternating current, after rectification, was used to charge the back-up battery. Thus, the total output power constituted more than 1,500,000 watts. The low-frequency voltage was obtained from the load windings and the direct current was obtained from the stabilisation chamber.

It should be noted that the high-voltage discharges of the 32 electrodes, ionise the partially pre-ionised water further. By means of the stimulation windings, a circulating magnetic field is created which moves the water in one direction inside the toroid. An electromotive force is created by the electromagnetic induction in a separate set of windings. As we already mentioned, during the movement of the water stream, free electrons are created, and an additional energy gets emitted because of the water's friction against the coating layer on the inside surface of the toroid, because of electrostatic breakdowns of cavity-vacuum structures, and because of the ongoing nuclear reaction.

If the dynamo's output is 1,000,000 watts, it's total input power is approximately 10,000 watts. So therefore the dynamo's energy efficiency is about 10,000%.

In addition to the barium titanate deposited on the teflon-coated inner surface of the polystyrene toroid, the water itself also contains tiny barium titanate crystals which are suspended in the water. Ultrasound at 25,000 cycles per second is propagated through the water to form micro-bubbles on the surfaces of the suspended barium titanate crystals. Again due to the barium titanate's piezoelectric action, very high electrostatic fields are also developed within the micro-bubbles at the surface of the crystals. The electrons from the nuclear reaction are added to the electrons generated at the toroid's interior surface. The total amount of mono-crystalline barium titanate in the Armenian dynamo was nearly 1000 grams. Satellites, locomotives, heavy trucks, airplanes, and ships are obvious transportation applications.

Dynamo Economics

The dynamo's production cost is estimated at \$500 per kilowatt which is very competitive when compared to nuclear power's capital costs of \$5,000 per kilowatt, windmill capital costs of \$4,000 per kilowatt, etc. A well-run nuclear power plant can generate power for 1.5 cents per kilowatt-hour, coal 1.8 cents, natural gas 3.4 cents, and oil 4.1 cents, on average. The dynamo's operating cost would be approximately 0.1 cent per kilowatt-hour with no external fuel needed and without any pollution being created.

These dynamos could replace all nuclear power plants, solar installations, wood-burning furnaces, hydro-electric generation, etc. A recent IEEE *Spectrum* article stated that the world's demand for electricity increases by approximately 500 megawatts every day. To put this in perspective, that is the equivalent of building another Hoover Dam every four days to keep up with the world's increasing electricity demand. Or, a dynamo manufacturing company would have to build another 500-megawatt dynamo every single day to keep up with world electricity increased demand (in addition to replace all existing generators fuelled by hydro, nuclear, and fossil fuels.)

The text of the patent application mentioned above is not in English although the abstract of the patent number WO 01/15305 A1 has been translated into English:

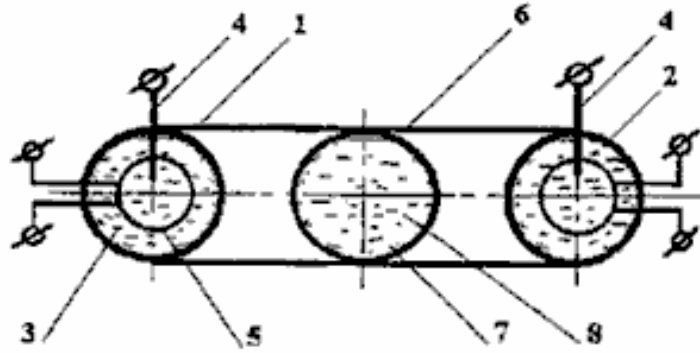

(57) **Abstract:** The invention is directed at increasing output, reliability and environmental safety of MHD generators as well as at simplifying the design of said generators. The inventive method for the production of energy comprises the following steps: a polar liquid (8) is circulated in a predetermined direction along a hermetically sealed toroidal channel (1) by means of a travelling magnetic field, and electric power is collected by means of electromagnetic winding. The liquid is ionized at least at the stage of launching, by means of electrodes (4), for example. The internal walls (2) of the channel have a dielectric constant which is higher than the dielectric constant of said liquid.

Patrick Kelly

<http://www.free-energy-info.tuks.nl/>

Chapter 6: Pulse-Charging Battery Systems

It is possible to draw substantial amounts of energy from the local environment and use that energy to charge batteries. Not only that, but when this method of charging is used, the batteries gradually get conditioned to this form of non-conventional energy and their capacity for doing work increases. In addition, about 50% of vehicle batteries abandoned as being incapable of holding their charge any longer, will respond to this type of charging and revive fully. This means that a battery bank can be created for almost no cost.

However, while this economic angle is very attractive, the practical aspect of using batteries for any significant home application is just not practical. Firstly, lead-acid batteries tend to get acid all over the place when repeatedly charged, and this is not suited to most home locations. Secondly, it is recommended that batteries are not discharged more rapidly than a twenty hour period. This means that a battery rated at a capacity of 80 Amp-hours (Ahr) should not be required to supply a current of more than 4 amps. This is a devastating restriction which pushes battery operation into the non-practical category, except for very minor loads like lights, TVs, DVD recorders and similar equipment with minimal power requirements.

The main costs of running a home are those of heating/cooling the premises and operating equipment like a washing machine. These items have a minimum load capacity of just over 2 kW. It makes no difference to the power requirement if you use a 12-volt, 24-volt or 48-volt battery bank. No matter which arrangement is chosen, the number of batteries needed to provide any given power requirement is the same. The higher voltage banks can have smaller diameter wiring as the current is lower, but the power requirement remains the same.

So, to provide a 2 kW load with power, requires a total current from 12-volt batteries of $2000 / 12 = 167$ amps. Using 80 Ahr batteries this is 42 batteries. Unfortunately, the charging circuits described below, will not charge a battery which is powering a load. This means that for a requirement like heating, which is a day and night requirement, there needs to be two of these battery banks, which takes us to 84 batteries. This is only for a minimal 2 kW loading, which means that if this is being used for heating, it is not possible to operate the washing machine unless the heating is turned off. So, allowing for some extra loading like this, the battery count reaches, perhaps, 126. Ignoring the cost, and assuming that you can find some way to get over the acid problem, the sheer physical volume of this number of batteries is just not realistic for domestic installation and use. In passing, you would also need two inverters with a 2500 watt capability

The recent charging system shown by 'UFOPolitics' in chapter 3, provides a very good and simple charging method which uses cold electricity. This can overcome the previous constraints imposed by using batteries, probably both with regards to current draw and with regards to recharging time. The Electrodyne Corp. staff who experimented extensively with the Tesla Switch circuitry, found that when a battery was fully conditioned to used cold electricity, that a battery could be disconnected, discharged independently to its full capacity, and then re-charged completely in under one minute. That style of operation completely overcomes the objections to using battery banks to power household equipment of any power.

Battery banks are used to power standard inverters which can look like this:



The battery connects at the back, using very thick wires, and one or more mains sockets on the front provide a power supply similar to the mains, matching it in both voltage and frequency. There is one variety of inverter

called a "True Sine-Wave" inverter and costing much more than the ordinary non-sinewave inverters. Most equipment works well on the ordinary variety. It is usually the power available from the battery bank which is the limiting factor, combined with the long time taken to recharge the battery bank after use.

John Bedini's Battery-Charging System.

John Bedini has designed a whole series of pulse-generator circuits, all based on the 1:1 multi-strand choke coil component disclosed in his patent US 6,545,444

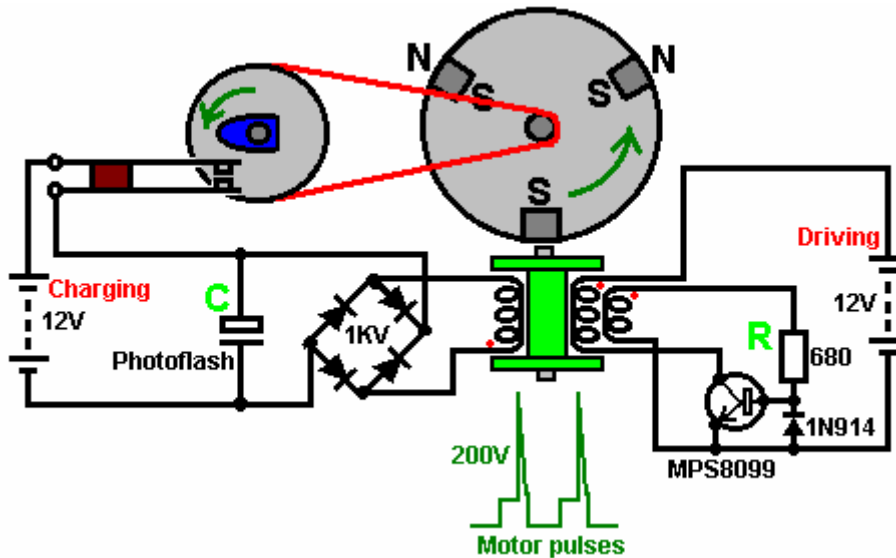

Roger Andrews' Switching System.

The very neat switching arrangement used by John is shown in detail in the earlier patent US 3,783,550 issued in 1974 where the same magnet-triggered boosting electromagnet pulse is used to power a whole series of movements. One of these is two magnetic spinning tops made to spin in a shallow dish:

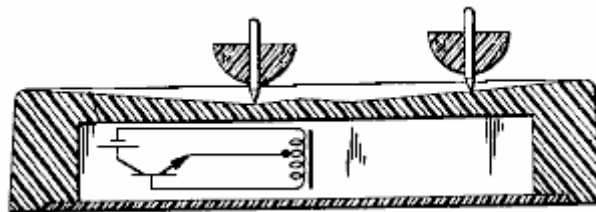

When the tops spin fast, they rise up the sloping base of the dish and spin near the outer edge. When they slow down they move back towards the centre of the dish and that triggers the battery/transistor/electromagnet built into the base of the dish. The pulse from the electromagnet boosts the spin of the top, sending it back up the slope. This is a very neat arrangement as the transistor is off most of the time and yet the two tops keep spinning.

Another of Roger's systems is shown here:

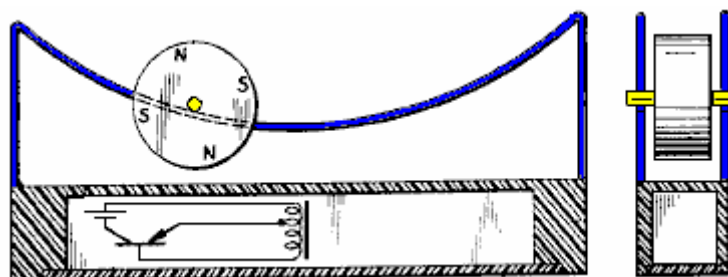

It operates in almost the same way, with a magnetic wheel rolling backwards and forwards along a curved track.

At the lowest point, the electromagnet is triggered by the induced voltage in some of the turns of the coil, powering the transistor and boosting the magnetic roller on it's way.

Another Andrews device is the pendulum where the passing magnet of the pendulum triggers a boosting pulse from the solenoid, keeping the pendulum swinging. John Bedini has also used this mechanism for a pulsed battery charging system and Veljko Milkovic has demonstrated that substantial mechanical power can be extracted from a lever which is powered by a pendulum.

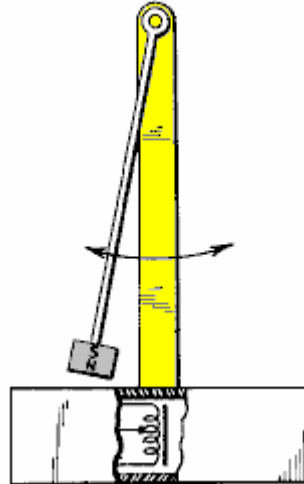

Andrews also shows a switching arrangement for a motor. This design is essentially the same as used by John Bedini in many of his pulsing systems:

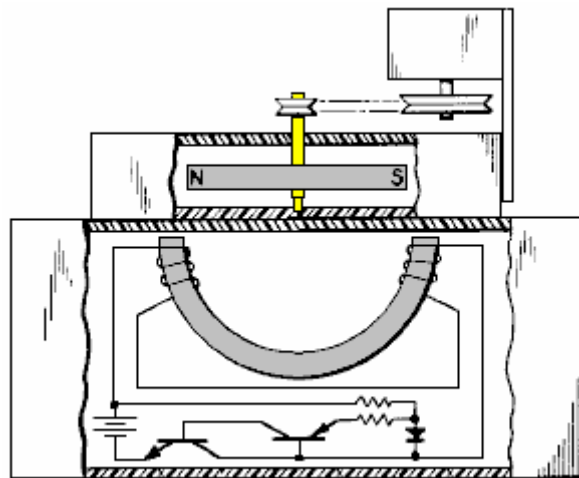

Here, as the rotor magnet passes the curved electromagnet in the base, it switches on the two transistors which produce a pulse which keeps the rotor spinning and the tiny generator turning. Andrews produced this for amusement as the rotor appears to spin on it's own without any drive power.

As with the Andrews system, the Bedini rotor is started spinning by hand. As a magnet passes the triple-wound "tri-filar" coil, it induces a voltage in all three coil windings. The magnet on the rotor is effectively contributing energy to the circuit as it passes the coil. One winding feeds a current to the base of the transistor via the resistor 'R'. This switches the transistor hard on, driving a strong current pulse from the battery through the second coil winding, creating a 'North' pole at the top of the coil, boosting the rotor on its way. As only a changing magnetic field generate a voltage in a coil winding, the steady transistor current through coil two is unable to sustain the transistor base current through coil one and the transistor switches off again.

The cutting of the current through the coil causes the voltage across the coils to overshoot by a major amount, moving outside the battery rail by a serious voltage. The diode protects the transistor by preventing the base voltage being taken below -0.7 volts. The third coil, shown on the left, picks up all of these pulses and rectifies them via a bridge of 1000V rated diodes. The resulting pulsing DC current is passed to the capacitor, which is one from a disposable camera, as these are built for high voltages and very rapid discharges. The voltage on the capacitor builds up rapidly and after several pulses, the stored energy in it is discharged into the "Charging"

battery via the mechanical switch contacts. The drive band to the wheel with the cam on it, provides a mechanical gearing down so that there are several charging pulses between successive closings of the contacts. The three coil windings are placed on the spool at the same time and comprise 450 turns of the three wires (mark the starting ends before winding the coil).

The operation of this device is a little unusual. The rotor is started off by hand and it progressively gains speed until its maximum rate is reached. The amount of energy passed to the coil windings by each magnet on the rotor stays the same, but the faster the rotor moves, the shorter the interval of time in which the energy is transferred. The energy input per second, received from the permanent magnets, increases with the increased speed.

If the rotation is fast enough, the operation changes. Up to now, the current taken from the 'Driving' battery has been increasing with the increasing speed, but now the driving current starts to drop although the speed continues to increase. The reason for this is that the increased speed has caused the permanent magnet to move past the coil before the coil is pulsed. This means that the coil pulse no longer has just to push against the 'North' pole of the magnet, but in addition it attracts the 'South' pole of the next magnet on the rotor, which keeps the rotor going and increases the magnetic effect of the coil pulse. John states that the mechanical efficiency of these devices is always below 100% efficient, but having said that, it is possible to get results of COP = 11. Many people who build these devices never manage to get COP > 1.

It is important that a standard mains powered battery charger is never used to charge these batteries. It is clear that the 'cold electricity' produced by a properly tuned Bedini device is substantially different to normal electricity although they can both perform the same tasks when powering electrical equipment. When starting to charge a lead-acid battery with radiant energy for the first time, it is recommended that the battery is first discharged to at least 1.7 volts per cell, which is about 10 volts for a 12 volts battery.

It is important to use the transistors specified in any of John's diagrams, rather than transistors which are listed as equivalents. Many of the designs utilise the badly named "negative resistance" characteristics of transistors. These semiconductors do not exhibit any form of negative resistance, but instead, show reduced positive resistance with increasing current, over part of their operating range.

It has been said that the use of "Litz" wire can increase the output of this device by anything up to 300%. Litz wire is the technique of taking three or more strands of wire and twisting them together. This is done with the wires stretched out side by side, by taking a length of say, three feet, and rotating the mid point of the bundle of wires for several turns in one direction. This produces clockwise twists for half the length and counter-clockwise twists for the remainder of the length. Done over a long length of wire, the wires are twisted repeatedly clockwise - counter clockwise - clockwise - counter clockwise - ... along their whole length. The ends of the wires are then cleared of their insulation and soldered together to make a three-strand cable, and the cable is then used to wind the coils. This style of winding modifies the magnetic and electrical properties of the windings. It has been said that taking three long strands of wire and just twisting them together in one direction to make a long twisted three-strand cable is nearly as effective as using Litz wire. The websites www.mwswire.com/litzmain.htm and www.litz-wire.com are suppliers of ready made Litz wire.

A website which shows pictures of John's devices is: www.rexresearch.com/bedini/images.htm

CAUTION: Care must be taken when working with batteries, especially lead-acid batteries. A charged battery contains a large amount of energy and short-circuiting the terminals will cause a very large current flow which may start a fire. When being charged, some batteries give off hydrogen gas which when mixed with air is highly dangerous and which could explode if ignited by a spark. Batteries can explode and/or catch fire if grossly overcharged or charged with an excessively large current, so there could be danger from flying pieces of the casing and possibly acid being thrown around. Even an apparently clean lead-acid battery can have caustic traces on the case, so you should be sure to wash your hands thoroughly after handling a battery. Batteries with lead terminals tend to shed small fragments of lead when clips are put on them. Lead is toxic, so please be sure to wash your hands after handling any part of a lead-acid battery. Remember too that some batteries can develop slight leaks so please protect against any leakage. If you decide to perform any experiments using batteries, that you do so entirely at your own risk and on your own responsibility. This set of documents is presented for information purposes only and you are not encouraged to do anything other than read the information.

Also, if you get one of John's pulse motors tuned correctly, it will accelerate to perhaps 10,000 rpm. This is great for picking up energy but if ceramic magnets are used, the speed can cause them to disintegrate and fly in all directions. People have had magnet fragments embedded in their ceiling. It would be wise to build a housing enclosing the rotor and magnets so that if the magnets disintegrate, all of the fragments are contained safely.

Ronald Knight's Professional Advice on Battery Safety.

Ronald Knight has many years of professional experience in handling batteries and in pulse-charging them. He

comments on battery safety as follows:

I have not heard of anyone having a catastrophic failure of a battery case in all the energy groups to which I belong and most of them use batteries in the various systems which I study. However, that does not mean that it cannot happen. The most common reason for catastrophic failure in the case of a lead-acid battery, is arcing causing failure in the grids which are assembled together inside the battery to make up the cells of the battery. Any internal arcing will cause a rapid build up of pressure from expanding Hydrogen gas, resulting in a catastrophic failure of the battery case.

I am a former maintenance engineer for U.S. Batteries, so I can say with confidence, that when you receive a new battery from at least that manufacturer, you receive a battery which has undergone the best test available to insure the manufacturer that he is not selling junk which will be sent back to him. It is a relatively easy test, and as it takes place during the initial charge, there is no wasted time nor is there one battery that escapes the pass-or-fail test. The battery is charged with the absolute maximum current which it can take. If the battery does not blow up due to internal arcing during the initial charge it is highly likely that it will not blow up under the regular use for which it was designed. However, all bets are off with used batteries that have gone beyond their expected life.

I have witnessed several catastrophic failures of battery cases daily at work. I have been standing right next to batteries (within 12 inches) when they explode (it is like a .45 ACP pistol round going off) and have only been startled and had to change my under shorts and Tyvek jump-suit, and wash off my rubber boots. I have been in the charge room with several hundred batteries at a time positioned very closely together and have seen batteries explode almost every working day and I have never seen two side by side blow, nor have I ever seen one fire or any flash damage to the case or surrounding area as a result. I have never even seen a flash but what I have seen tells me it is wise to always wear eye protection when charging.

I have my new gel cells in a heavy plastic zip-lock bags partly unzipped when in the house and in a marine battery box outside in the garage, that is just in the remote chance of catastrophic failure or the more likely event of acid on the outside of the battery case.

Vented batteries are always a risk of spillage which is their most common hazard, they should always be in a plastic lined cardboard or plastic box with sides taller than the battery and no holes in it. You would be surprised at how far away I have found acid around a vented lead acid battery under charge.

Have an emergency plan, keep a box of baking soda and a water source around to neutralise and flush the acid in case of spillage. It is best to have plastic under and around wherever your lead-acid batteries are located.

Ronald Knight gets about fifteen times more power from his Bedini-charged batteries than is drawn from the driving side of the circuit. He stresses that this does not happen immediately, as the batteries being charged have to be "conditioned" by repeated cycles of charging and discharging. When this is done, the capacity of the batteries being charged increases. Interestingly, the rate of current draw on the driving side of the circuit is not increased if the battery bank being charged is increased in capacity. This is because the power which charges the batteries flows from the environment and not from the driving battery. The driving battery just produces the high-voltage spikes which trigger the energy flow from the environment, and as a consequence of that the battery bank being charged can be a higher voltage than the 12-volt driving battery, and there can be any number of batteries in the charging bank.

Ron Pugh's Battery Charger.

John Bedini's designs have been experimented with and developed by a number of enthusiasts. This in no way detracts from fact that the whole system and concepts come from John and I should like to express my sincere thanks to John for his most generous sharing of his systems. Thanks is also due to Ron Pugh who has kindly agreed for the details of one of his Bedini generators to be presented here. Let me stress again, that if you decide to build and use one of these devices, you do so entirely at your own risk and no responsibility for your actions rests with John Bedini, Ron Pugh or anyone else. Let me stress again that this document is provided for information purposes only and is not a recommendation or encouragement for you to build a similar device.

Ron's device is much more powerful than the average system, having fifteen coil windings and it performs most impressively. Here is a picture of it rotating at high speed:



This is not a toy. It draws significant current and produces substantial charging rates. This is how Ron chose to build his device. The rotor is constructed from aluminium discs which were to hand but he would have chosen aluminium for the rotor if starting from scratch as his experience indicates that it is a very suitable material for the rotor. The rotor has six magnets inserted in it. These are evenly spaced 60 degrees apart with the North poles all facing outwards.

The magnets are normal ceramic types about 22 mm wide, 47 mm long and 10 mm high. Ron uses two of these in each of his six rotor slots. He bought several spare ones and then graded all of them in order of their magnetic strength, which varies a bit from magnet to magnet. Ron did this grading using a gauss meter. An alternative method would have been to use a paper clip about 30 mm in size and measure the distance at which one end of the clip just starts to rise up off the table as the magnet is moved towards it:

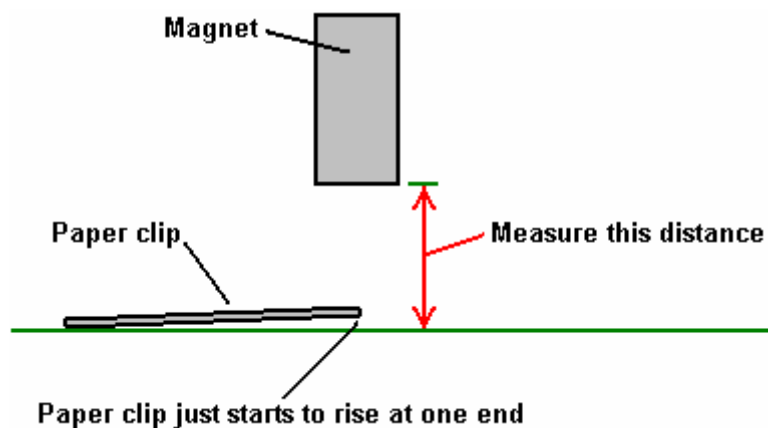

Having graded the magnets in order of strength, Ron then took the best twelve and paired them off, placing the

weakest and strongest together, the second weakest and the second strongest, and so on. This produced six pairs which have fairly closely matching magnetic strengths. The pairs of magnets were then glued in place in the rotor using super glue:

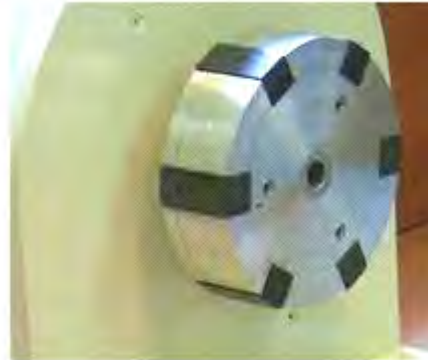
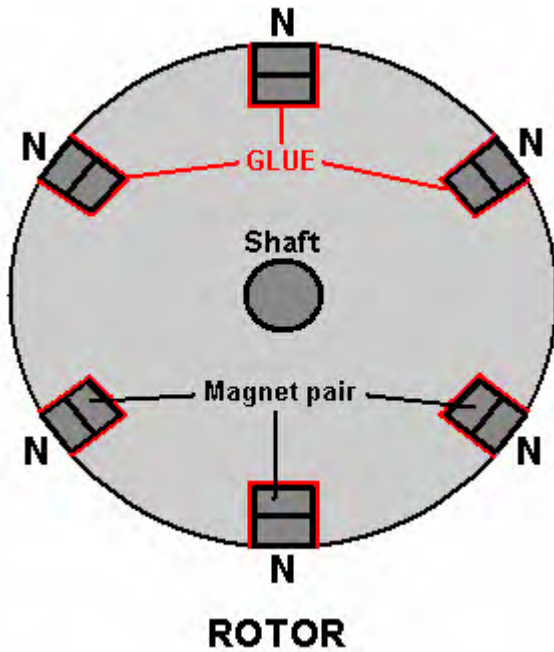

It is not desirable to recess the magnets though it is possible to place a restraining layer around the circumference of the rotor as the clearance between the magnet faces and the coils is about a quarter of an inch (6 mm) when adjusted for optimum performance. The North poles of the magnets face outwards as shown in the diagram above. If desired, the attachment of the magnets can be strengthened by the addition of blank side plates to the rotor which allows the magnet gluing to be implemented on five of the six faces of the magnet pairs:

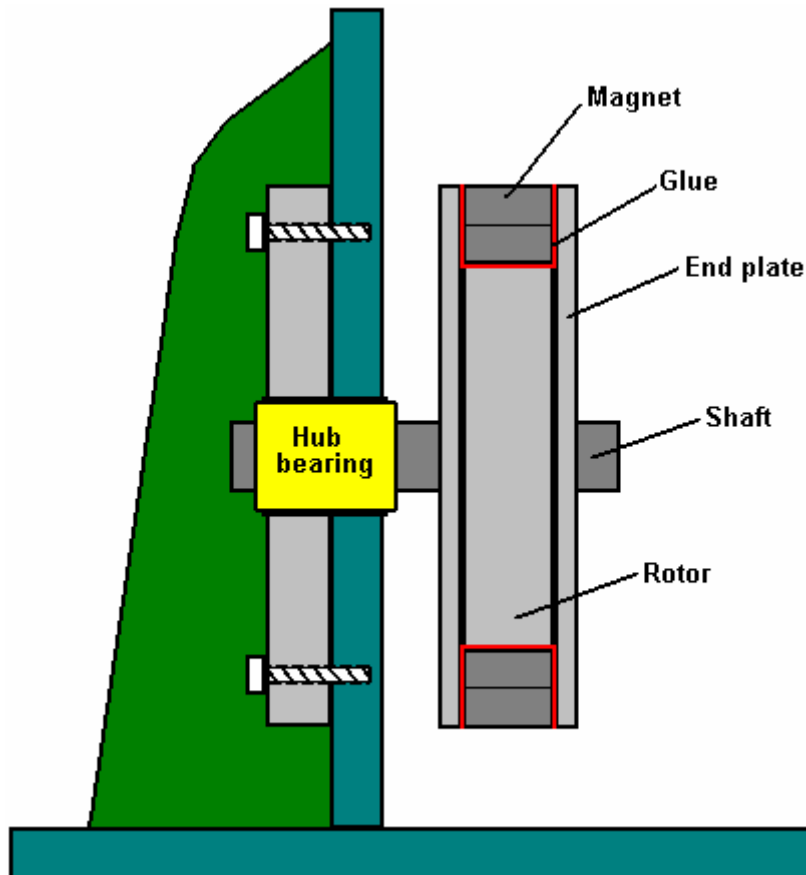

The magnets embedded in the outer edge of the rotor are acted on by wound “coils” which act as 1:1 transformers, electromagnets, and pickup coils. There are three of these “coils”, each being about 3 inches long and wound with five strands of #19 AWG (20 SWG) wire. The coil formers were made from plastic pipe of 7/8 inch (22 mm) outer diameter which Ron drilled out to an inner diameter of 3/4 inch (19 mm) which gives a wall thickness of 1/16 inch (1.5 mm). The end pieces for the coil formers were made from 1/8 inch (3 mm) PVC which was fixed to the plastic tube using plumbers PVC glue. The coil winding was with the five wires twisted around each other. This was done by clamping the ends of the five wires together at each end to form one 120 foot long bundle.

The bundle of wires was then stretched out and kept clear of the ground by passing it through openings in a set of patio chairs. A battery-powered drill was attached to one end and operated until the wires were loosely twisted together. This tends to twist the ends of the wires together to a greater extent near the end of the bundle rather than the middle. So the procedure was repeated, twisting the other end of the bundle. It is worth remarking in passing, that the drill turns in the same direction at each end in order to keep the twists all in the same direction. The twisted bundle of wires is collected on a large-diameter reel and then used to wind one of the “coils”.

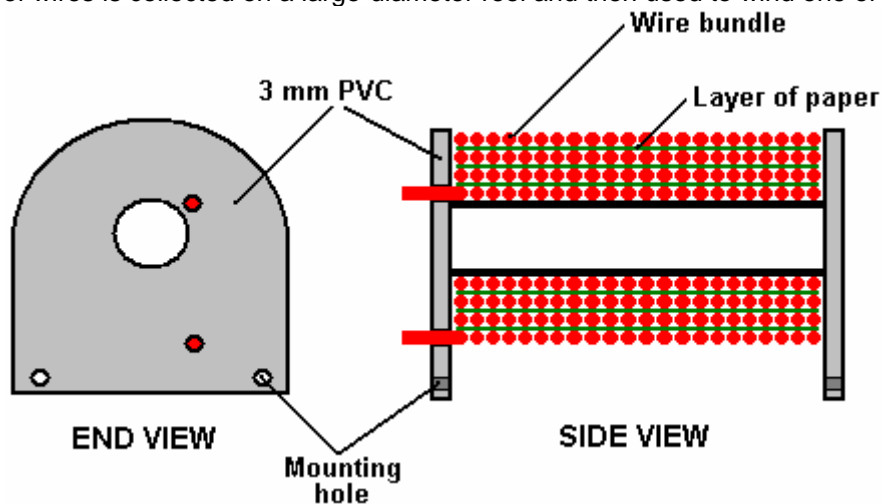

The coils are wound with the end plates attached and drilled ready to screw to their 1/4 inch (6 mm) PVC bases, which are the bolted to the 3/4 inch (18 mm) MDF supporting structure. To help the winding to remain completely even, a piece of paper is placed over each layer of the winding:

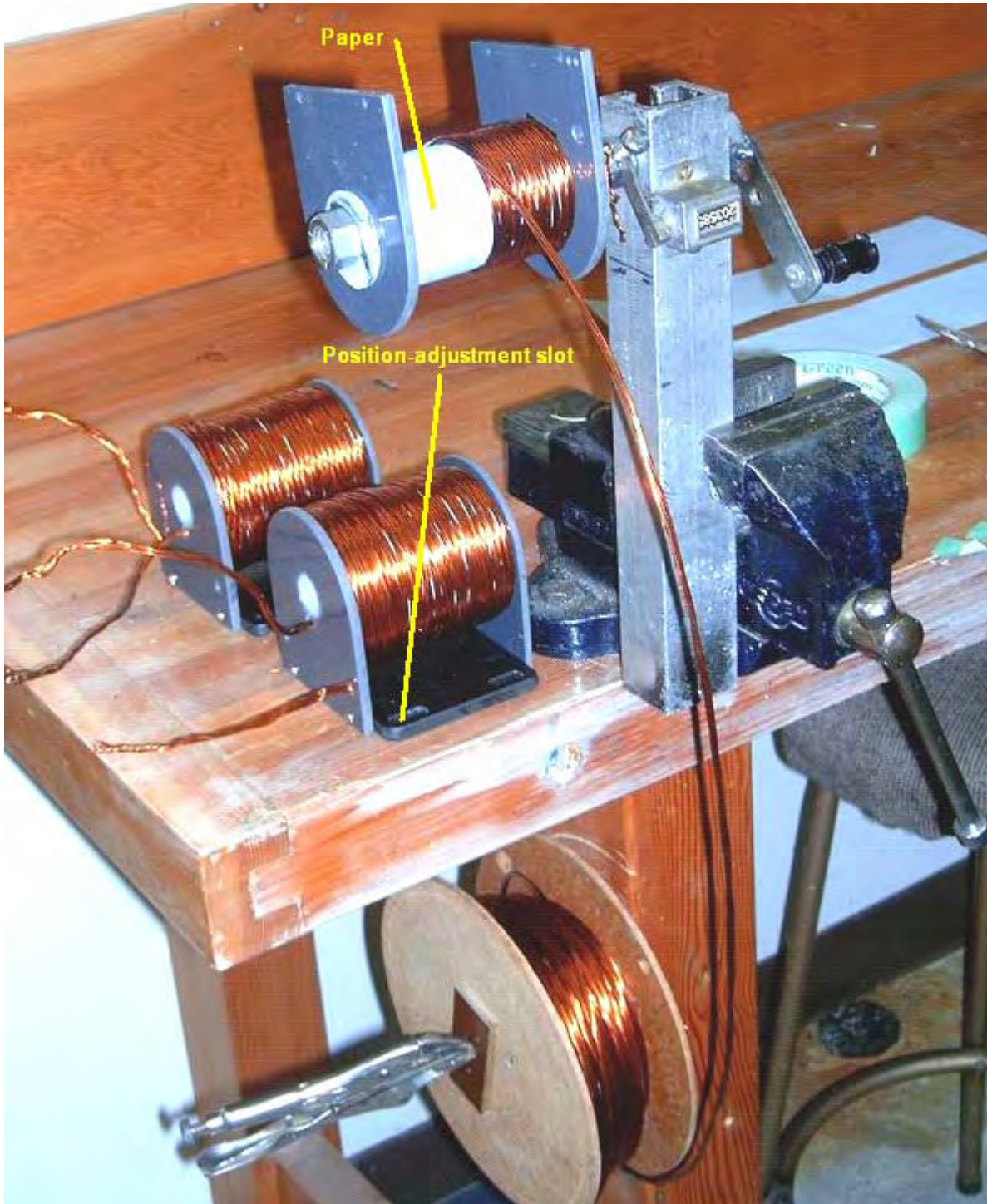

The three coils produced in this way were then attached to the main surface of the device. There could just as easily have been six coils. The positioning is made so as to create an adjustable gap of about 1/4 inch (6 mm) between the coils and the rotor magnets in order to find the optimum position for magnetic interaction. The magnetic effects are magnified by the core material of the coils. This is made from lengths of oxyacetylene welding wire which is copper coated. The wire is cut to size and coated with clear shellac to prevent energy loss through eddy currents circulating inside the core.

The coils are positioned at equal intervals around the rotor and so are 120 degrees apart. The end pieces of the coil formers are bolted to a 1/4 inch (6 mm) PVC base plate which has slotted mounting holes which allow the magnetic gap to be adjusted as shown here:

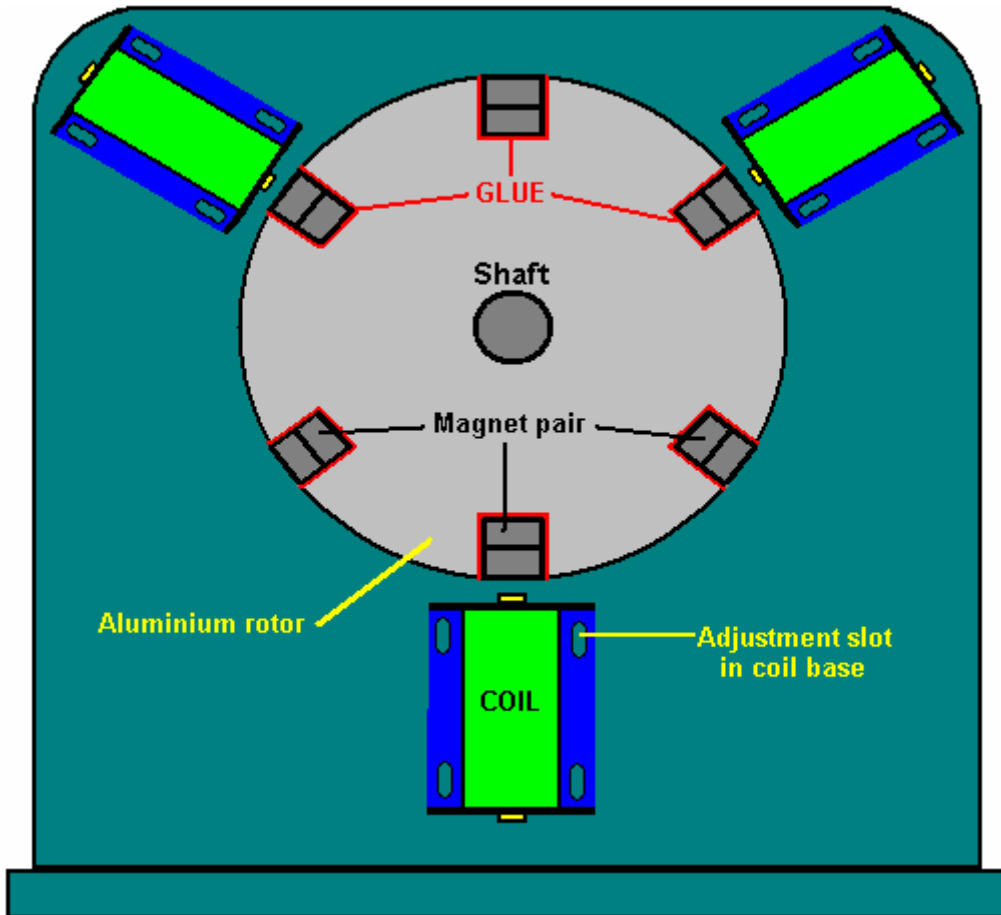

The three coils have a total of fifteen identical windings. One winding is used to sense when a rotor magnet reaches the coils during its rotation. This will, of course happen six times for each revolution of the rotor as there are six magnets in the rotor. When the trigger winding is activated by the magnet, the electronics powers up all of the remaining fourteen coils with a very sharp, pulse which has a very short rise time and a very short fall time. The sharpness and brevity of this pulse is a critical factor in drawing excess energy in from the environment and will be explained in greater detail later on. The electronic circuitry is mounted on three aluminium heat sinks, each about 100 mm square. Two of these have five BD243C NPN transistors bolted to them and the third one has four BD243C transistors mounted on it.

The metal mounting plate of the BD243 transistors acts as its heat sink, which is why they are all bolted to the large aluminium plate. BD243C transistors look like this:

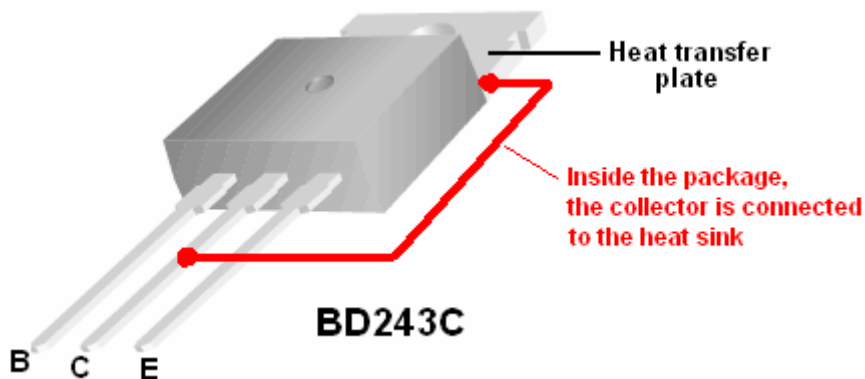

The circuit has been built on the aluminium panels so that the transistors can be bolted directly on to it, and provided with insulating strips mounted on top of it to avoid short circuits to the other components. Standard strip connector blocks have been used to inter-connect the boards which look like this:

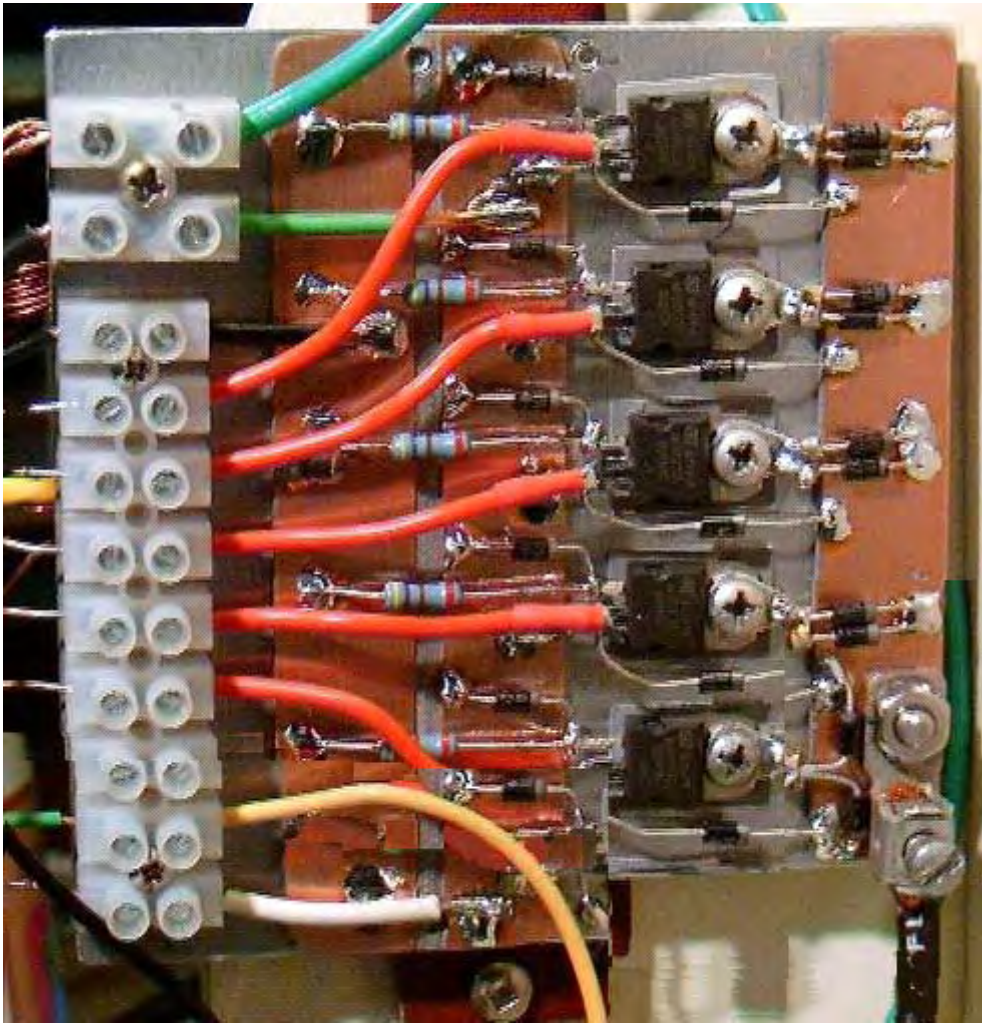

The circuit used with this device is simple but as there are so many components involved, the diagram is split into parts to fit on the page. These diagrams are usually drawn with a common charging wire going to the top of the battery which is being charged. However, it needs to be understood that drawing it that way is just for convenience and better performance is achieved if each charging circuit has its own separate wire going to the charging battery as shown in Section 1 here:

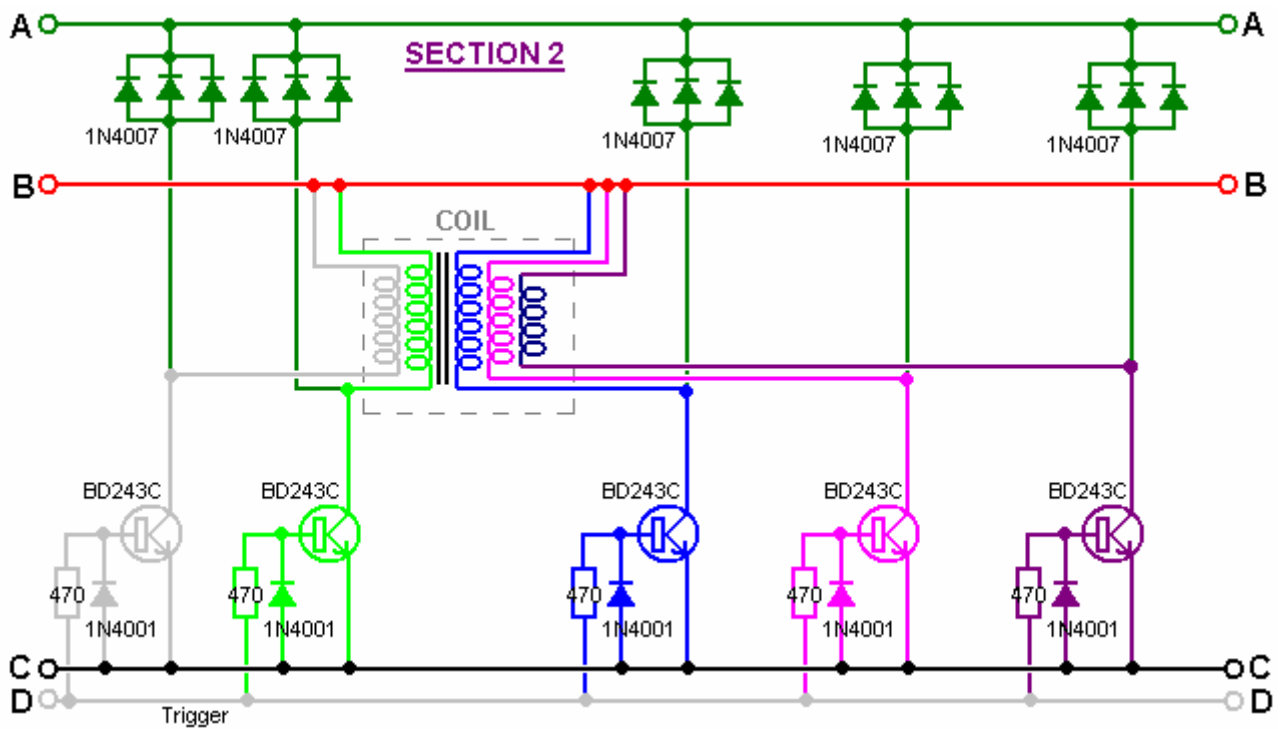
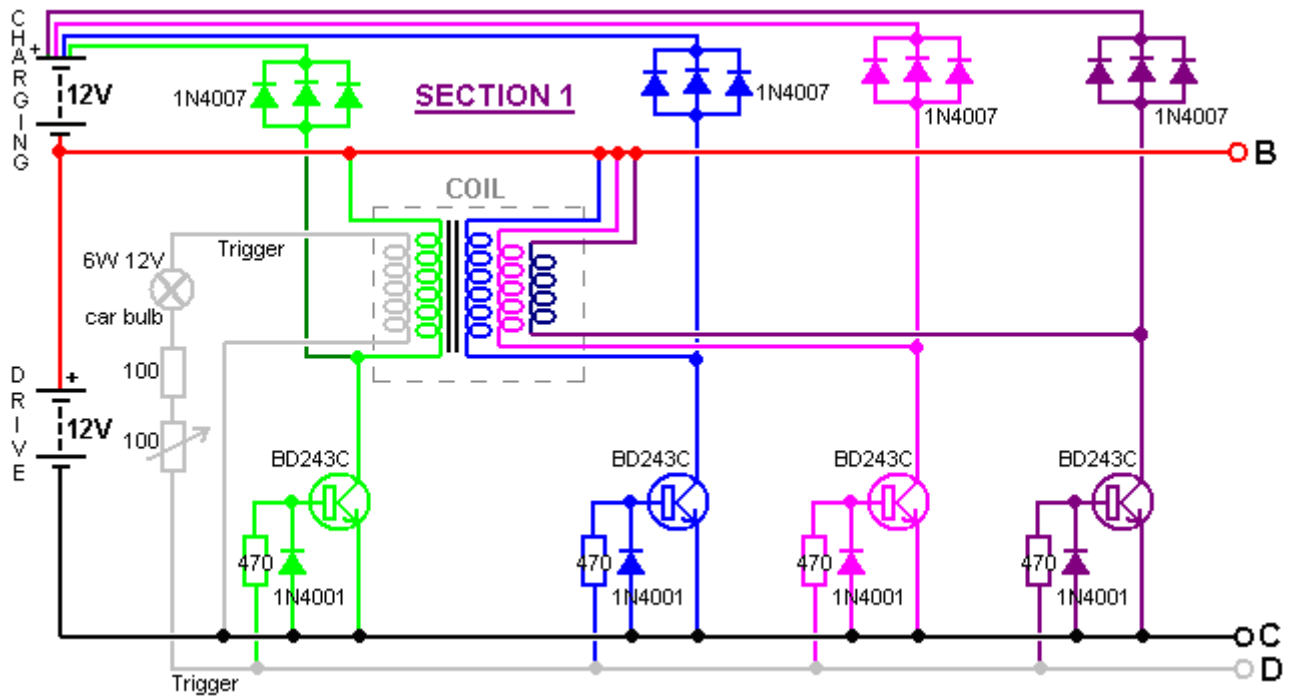

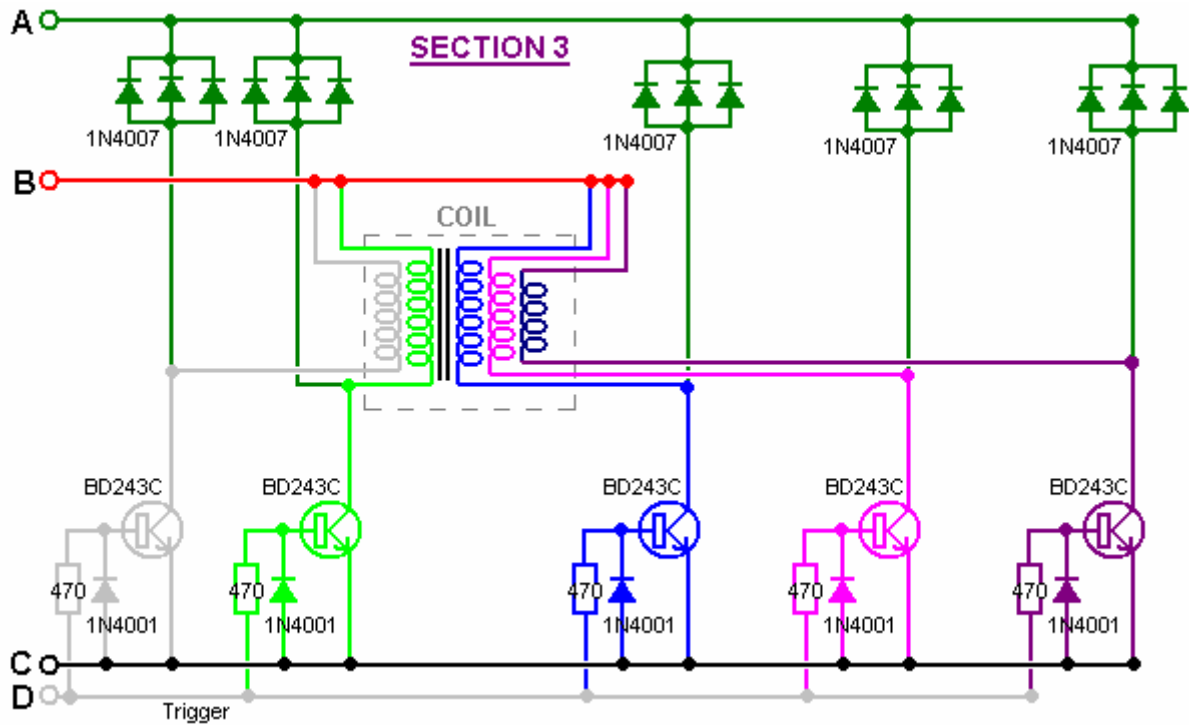

While this looks like a fairly large and complicated circuit, it actually is not. You will notice that there are fourteen identical circuit sections. Each of these is quite simple:

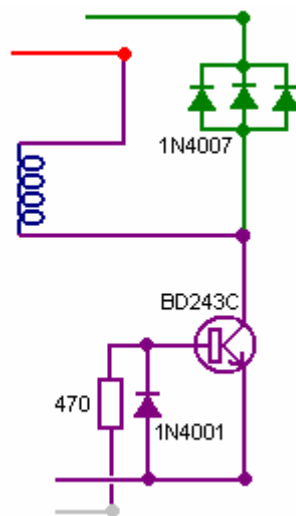

This is a very simple transistor circuit. When the trigger line goes positive (driven by the magnet passing the coil) the transistor is switched on hard, powering the coil which is then effectively connected across the driving battery. The trigger pulse is quite short, so the transistor switches off almost immediately. This is the point at which the circuit operation gets subtle. The coil characteristics are such that this sharp powering pulse and sudden cut-off cause the voltage across the coil to rise very rapidly, dragging the voltage on the collector of the transistor up to several hundred volts. Fortunately, this effect is energy drawn from the environment which is quite unlike conventional electricity, and thankfully, a good deal less damaging to the transistor. This rise in voltage, effectively "turns over" the set of three 1N4007 diodes which then conducts strongly, feeding this excess free-energy into the charging battery. Ron uses three diodes in parallel as they have a better current-carrying capacity and thermal characteristics than a single diode. This is a common practice and any number of diodes can be placed in parallel, with sometimes as many as ten being used.

The only other part of the circuit is the section which generates the trigger signal:

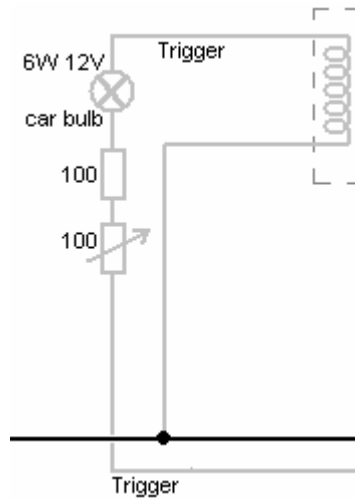

When a magnet passes the coil containing the trigger winding, it generates a voltage in the winding. The intensity of the trigger signal is controlled by passing it through an ordinary vehicle 6 watt, 12 volt bulb and then further limiting the current by making it pass through a resistor. To allow some manual control of the level of the trigger signal, the resistor is divided into a fixed resistor and a variable resistor (which many people like to call a "pot"). This variable resistor and the adjustment of the gap between the coils and the rotor are the only adjustments of the device. The bulb has more than one function. When the tuning is correct, the bulb will glow dimly which is a very useful indication of the operation. The trigger circuit then feeds each of the transistor bases via their 470 ohm resistors.

John Bedini aims for an even more powerful implementation, wiring his circuit with AWG #18 (19 SWG) heavy-duty copper wire and using MJL21194 transistors and 1N5408 diodes. He increases the trigger drive by dropping the variable resistor and reducing fixed resistor to just 22 ohms. The MJL21194 transistor has the same pin connections as the BD243C transistor. This is the starting section of John's circuit:

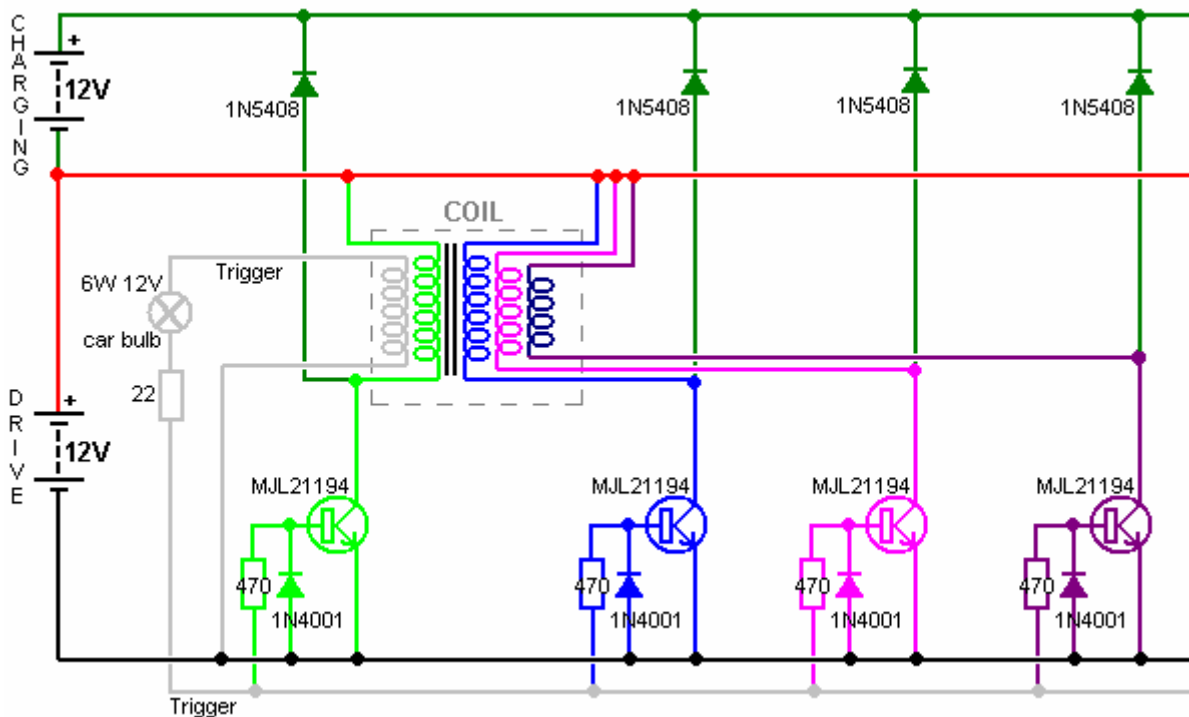

There are various ways of constructing this circuit. Ron shows two different methods. The first is shown above and uses paxolin strips (printed-circuit board material) above the aluminium heat sink to mount the components. Another method which is easy to see, uses thick copper wires held clear of the aluminium, to provide a clean and secure mounting for the components as shown here:

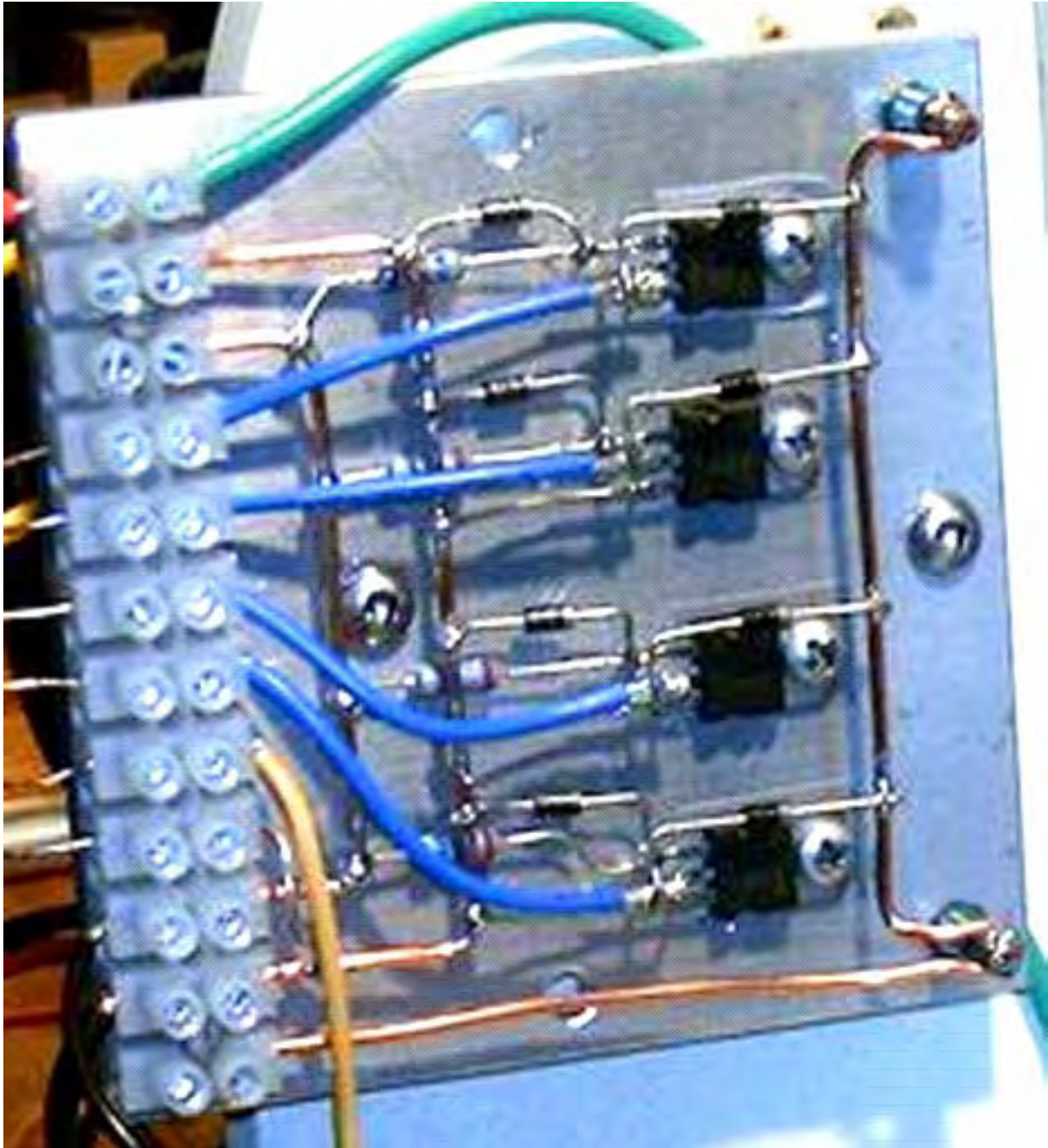

It is important to realise that the collector of a BD243C transistor is internally connected to the heat-sink plate used for the physical mounting of the transistor. As the circuit does not have the collectors of these transistors connected together electrically, they cannot just be bolted to a single heat-sink plate. The above picture might give the wrong impression as it does not show clearly that the metal bolts fastening the transistors in place do not go directly into the aluminium plate, but instead, they fasten into plastic tee-nuts.

An alternative, frequently used by the builders of high-powered electronic circuits, is to use mica washers between the transistor and the common heat sink plate, and use plastic fastening bolts or metal bolts with a plastic insulating collar between the fastening and the plate. Mica has the very useful property of conducting heat very well but not conducting electricity. Mica “washers” shaped to the transistor package are available from the suppliers of the transistors. In this instance, it seems clear that heat dissipation is not a problem in this circuit, which in a way is to be expected as the energy being drawn from the environment is frequently called “cold” electricity as it cools components down with increasing current as opposed to heating them up as conventional electricity does.

This particular circuit board is mounted at the rear of the unit:

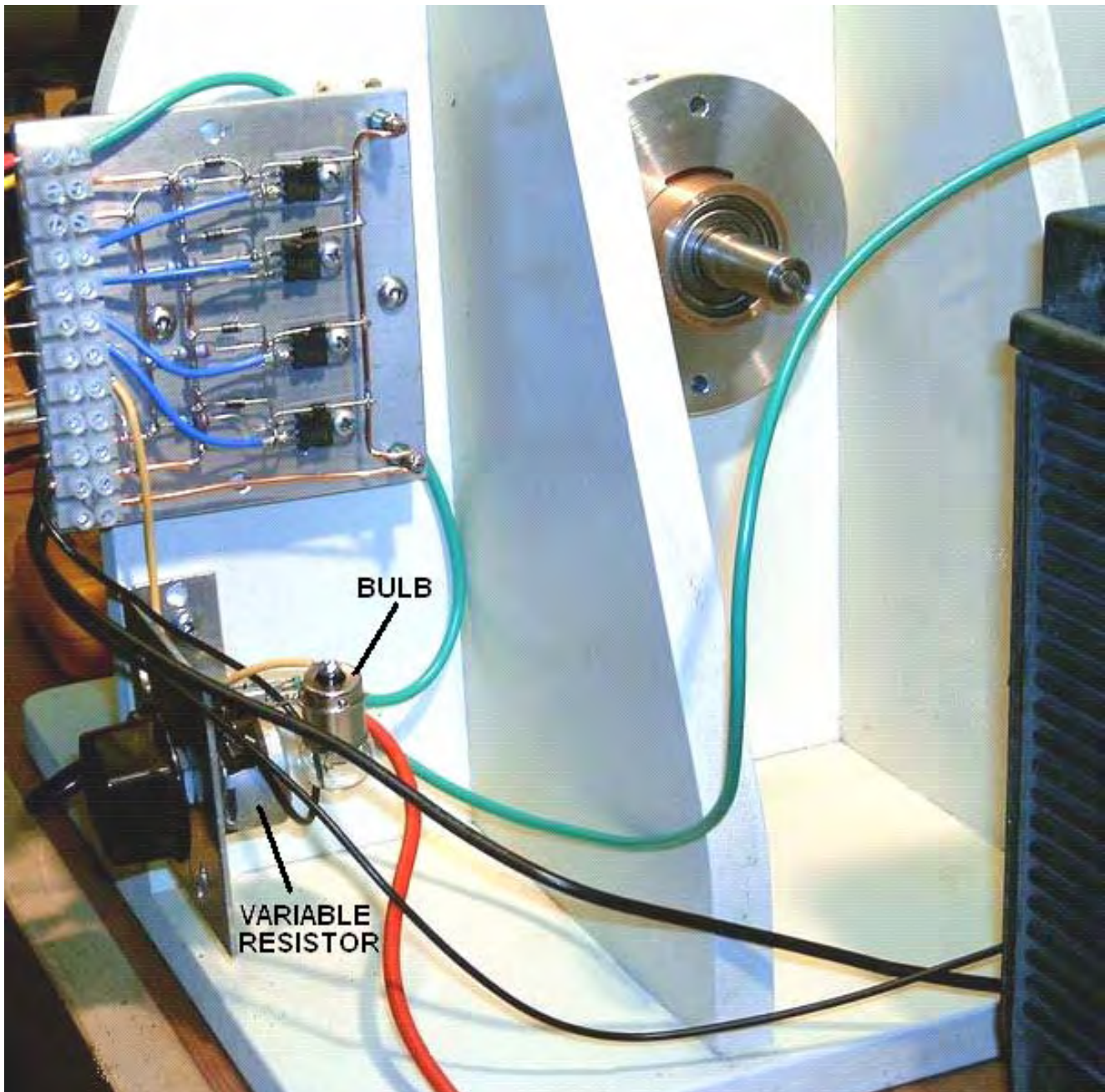

Although the circuit diagram shows a twelve volt drive supply, which is a very common supply voltage, Ron sometimes powers his device with a mains operated Power Supply Unit which shows a power input of a pretty trivial 43 watts. It should be noted that this device operates by pulling in extra power from the environment. That drawing in of power gets disrupted if any attempt is made to loop that environmental power back on itself or driving the unit directly from another battery charged by the unit itself. It may be just possible to power the unit successfully from a previously charged battery if an inverted is used to convert the power to AC and then a step-down transformer and regulated power rectification circuit is used. As the power input is so very low, off-grid operation should be easily possible with a battery and a solar panel.

It is not possible to operate a load off the battery under charge during the charging process as this disrupts the energy flow. Some of these circuits recommend that a separate 4 foot long earthing rod be used to earth the negative side of the driving battery, but to date, Ron has not experimented with this. In passing, it is good practice to enclose any lead-acid battery in a battery box. Marine chandlers can supply these as they are used extensively in boating activities.

When cutting the wire lengths for coating and pushing into the coil formers, Ron uses a jig to ensure that all of the lengths are identical. This arrangement is shown here:



The distance between the shears and the metal angle clamped to the workbench makes each cut length of wire exactly the required size while the plastic container collects the cut pieces ready for coating with clear shellac or clear polyurethane varnish before use in the coil cores.

Experience is particularly important when operating a device of this kind. The 100 ohm variable resistor should be a wire-wound type as it has to carry significant current. Initially the variable resistor is set to its minimum value and the power applied. This causes the rotor to start moving. As the rate of spin increases, the variable resistor is gradually increased and a maximum speed will be found with the variable resistor around the middle of its range, i.e. about 50 ohm resistance. Increasing the resistance further causes the speed to reduce.

The next step is to turn the variable resistor to its minimum resistance position again. This causes the rotor to leave its previous maximum speed (about 1,700 rpm) and increase the speed again. As the speed starts increasing again, the variable resistor is once again gradually turned, increasing its resistance. This raises the rotor speed to about 3,800 rpm when the variable resistor reaches mid point again. This is probably fast enough for all practical purposes, and at this speed, even the slightest imbalance of the rotor shows up quite markedly. To go any faster than this requires an exceptionally high standard of constructional accuracy. Please remember that the rotor has a large amount of energy stored in it at this speed and so is potentially very dangerous. If the rotor breaks or a magnet comes off it, that stored energy will produce a highly dangerous projectile. That is why it is advisable, although not shown in the above photographs, to construct an enclosure for the rotor. That could be a U-shaped break channel between the coils. The channel would then catch and restrain any fragments should anything break loose.

If you were to measure the current during this adjustment process, it would be seen to reduce as the rotor speeds up. This looks as if the efficiency of the device is rising. That may be so, but it is not necessarily a good thing in this case where the objective is to produce radiant energy charging of the battery bank. John Bedini has shown that serious charging takes place when the current draw of the device is 3 to 5+ amps at maximum rotor speed and not a miserly 50 mA draw, which can be achieved but which will not produce good charging. The power can

be increased by raising the input voltage to 24 volts or even higher - John Bedini operates at 48 volts rather than 12 volts

The device can be further tuned by stopping it and adjusting the gap between the coils and the rotor and then repeating the start-up procedure. The optimum adjustment is where the final rotor speed is the highest.

The above text is intended to give a practical introduction to one of John Bedini's inventions. It seems appropriate that some attempt at an explanation of what is happening, should be advanced at this point. In the most informative book "Energy From The Vacuum - Concepts and Principles" by Tom Bearden an explanation of this type of system is put forward. While the description appears to be aimed mainly at John's motor system which ran continuously for three years, powering a load and recharging it's own battery, the description would appear to apply to this system as well. I will attempt to summarise it here:

Conventional electrical theory does not go far enough when dealing with lead/acid batteries in electronic circuits. Lead/acid batteries are extremely non-linear devices and there is a wide range of manufacturing methods which make it difficult to present a comprehensive statement covering every type in detail. However, contrary to popular belief, there are actually at least three separate currents flowing in a battery-operated circuit:

1. Ion current flowing in the electrolyte between the plates inside the battery. This current does not leave the battery and enter the external electronic circuit.
2. Electron current flowing from the plates out into the external circuit.
3. Current flow from the environment which passes along the external circuitry and into the battery.

The exact chemical processes inside the battery are quite complex and involve additional currents which are not relevant here. The current flow from the environment follows the electron flow around the external circuit and on into the battery. This is "cold" electricity which is quite different to conventional electricity and it can be very much larger than the standard electrical current described in conventional textbooks. A battery has unlimited capacity for this kind of energy and when it has a substantial "cold" electricity charge, it can soak up the conventional energy from a standard battery charger for a week or more, without raising the battery voltage at all.

An important point to understand is that the ions in the lead plates of the battery have much greater inertia than electrons do (several hundred thousand times in fact). Consequently, if an electron and an ion are both suddenly given an identical push, the electron will achieve rapid movement much more quickly than the ion will. It is assumed that the external electron current is in phase with the ion current in the plates of the battery, but this need not be so. John Bedini deliberately exploits the difference of momentum by applying a very sharply rising potential to the plates of the battery.

In the first instant, this causes electrons to pile up on the plates while they are waiting for the much heavier ions to get moving. This pile up of electrons pushes the voltage on the terminal of the battery to rise to as much as 100 volts. This in turn, causes the energy to flow back out into the circuit as well as into the battery, giving simultaneously, both circuit power and serious levels of battery charging. This over potential also causes much increased power flow from the environment into the circuit, giving augmented power both for driving the external circuit and for increasing the rate of battery charge. The battery half of the circuit is now 180 degrees out of phase with the circuit-powering half of the circuit.

It is important to understand that the circuit-driving energy and the battery-charging energy do **not** come from the sharp pulses applied to the battery. Instead, the additional energy flows in from the environment, triggered by the pulses generated by the Bedini circuit. In other words, the Bedini pulses act as a tap on the external energy source and are not themselves the source of the extra power.

If the Bedini circuit is adjusted correctly, the pulse is cut off very sharply just before the tapped energy inflow is about to end. This has a further enhancing effect due to the Lenz law reaction which causes an induced voltage surge which can take the over-voltage potential to as much as 400 volts. This has a further effect on the local environment, drawing in an even higher level of additional power and extending the period of time during which that extra power flows into both the circuit and the battery. This is why the exact adjustment of a Bedini pulsing system is so important.

Ossie Callanan's Free-Energy System

In 2007, Ossie Callanan published a document showing how and why he was getting COP>1 battery charging. Ron Pugh's system kindly shared in detail above, with careful tuning and running on 24 volt input and 24 volt

output operates at COP>10 which is likely to be due to Ron's skill in building and adjusting, both of which are very good indeed, coupled with the use of many transistors working in parallel and tripled charging diodes to improve their performance. The John Bedini SSG pulse-charging system is very easy to construct and works very well, even with many sulphated batteries which have been discarded as useless. However, most people will not get COP>1 performance from their own SSG build. Ossie explains why this is in the following section which is his Copyright. He says:

I believe I may have this radiant energy system worked out to the point where anyone can build it and when you build all of it, it can provide you with free and continuous energy. There are two sides to the circuit and just having either side is no good, you must have both. One side is the pulse-charger side, and the other is the battery and accumulator-converter side. At present, I am charging batteries at a performance level between COP=2 and COP=10 and battery swapping is not a problem.

First we need to focus on the charger side of the system. Basically, you must build a charger which produces large amounts of radiant energy in the form of radiant pulses. Radiant energy pulses are Back-EMF pulses provided that they have very fast rising edges and falling edges and occur at high frequencies. They are **not** transistor transients or switching transients! A spark-gap produces classical radiant energy pulses. They are chaotic events but they are radiant energy events nevertheless. Switching a coil on very rapidly using a transistor will produce one radiant energy pulse from the coil's Back-EMF, but one pulse on its own is no good. You need thousands or better still, millions of those pulses for them to be of any practical use.

John Bedini's Simplified School Girl motor (the "SSG") only produces a very small amount of radiant energy when you have the base of the transistor tuned so that you get the longest self oscillating pulse train per magnet pass. It is not very efficient as the base-clamping diode wastes this energy, passing it back through the base resistor-bulb circuit but that circuit it is necessary so that you can synchronise the operation and provide a driving force to the passing magnet. Without the base-clamping diode, you get an oscillator and the motor won't turn - catch 22. But still, even when tuned with the base-clamping diode in place, the self-oscillating pulse train is usually at most 3 to 6 pulses which is not very much and so, not much radiant energy is produced. For all those people trying to tune the motor for only one pulse per magnet pass, they are wasting their time and only building a pulse motor and not an efficient radiant energy generator.

The SSG is not a very powerful or good radiant energy generator and apart from being educational, it is really a waste of time unless someone can explain to you how to tune it to get the greatest possible amount of radiant energy from it with a long pulse train, and then tell you what to do with that radiant energy. John Bedini's method of using a bulb in the base-feed circuit is to keep the motor tuned to a particular number of pulses in the pulse train per magnet pass or for the longest pulse train as the motor increases speed, also, the battery's impedance changes the speed as well. The two-strand coil where one coil is used just as the transistor trigger, along with the wasted energy in the base circuit, add to the overall inefficiency and make construction more difficult.

In saying that about the SSG I would like to show you now a very simple and basic pulse oscillator or motor driver circuit that you can build with off the shelf parts, one which will produce very large amounts of radiant energy when adjusted correctly. Here is that circuit:

Basic Radiant Pulse Oscillator / Motor-Driver Circuit

By Ossie Callanan

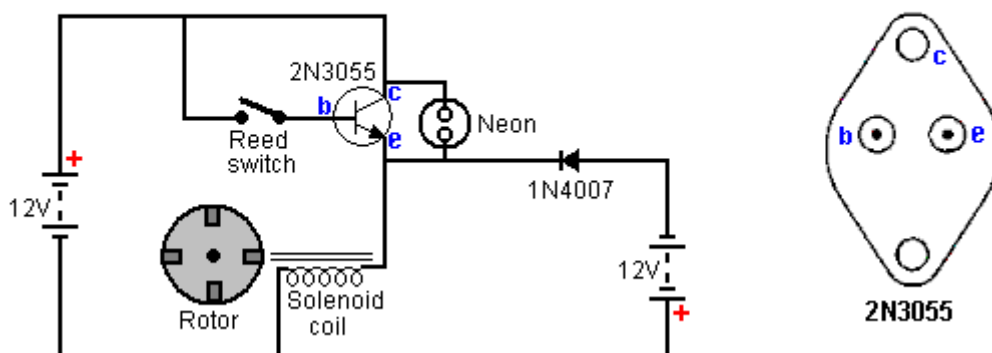

Do not be fooled by appearances - this is as close to a controlled spark gap circuit as you are going to get and it is extremely efficient in the production of radiant energy! But most importantly, you must place and adjust the reed switch appropriately and properly!!! Take a look at this picture:



As you can see, the trick is to place the reed switch so that it runs along the length of the solenoid coil and so is located in the coil's magnetic field. This couples the coil's magnetic field to the reed switch as well as the magnetic field of the passing rotor magnet. This provides a magnetic feedback and turns the reed switch into an oscillator. So when the magnet passes the reed oscillates with the coil's field and causes very many pulses, typically 20 to 50 pulses per magnet pass. Amazingly, unlike the clamping diodes in the SSG, this is not wasteful. This reed switch oscillation actually reduces the input current. Instead of the reed remaining closed for the whole of the pulse duration, it switches on and off and so, less input power is drawn from the driving battery. I run the motor so that when the coil is energised, the magnet is attracted to the coil. Here is a trace across the charging battery:

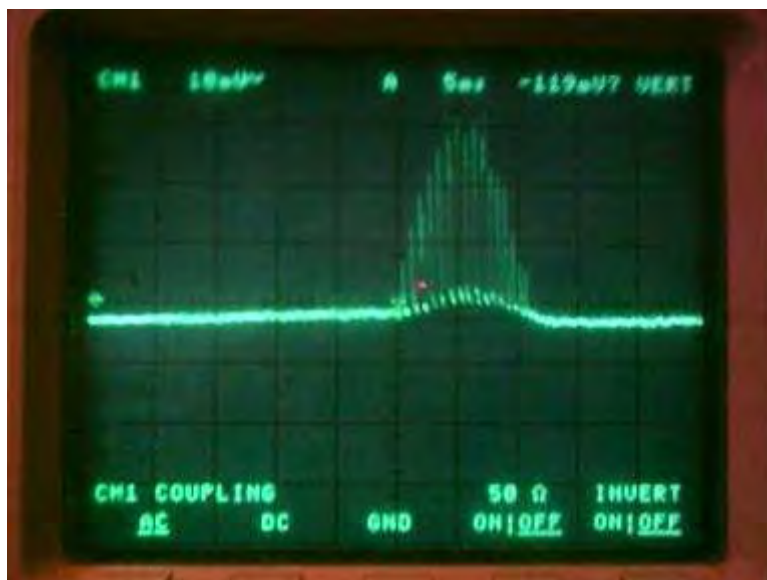

The trace above is from a motor that is only drawing 50 milliamps but is charging the battery many times faster than if it were drawing 300 milliamps with a single pulse per magnet pass! But there is more. Take a look at the following picture:

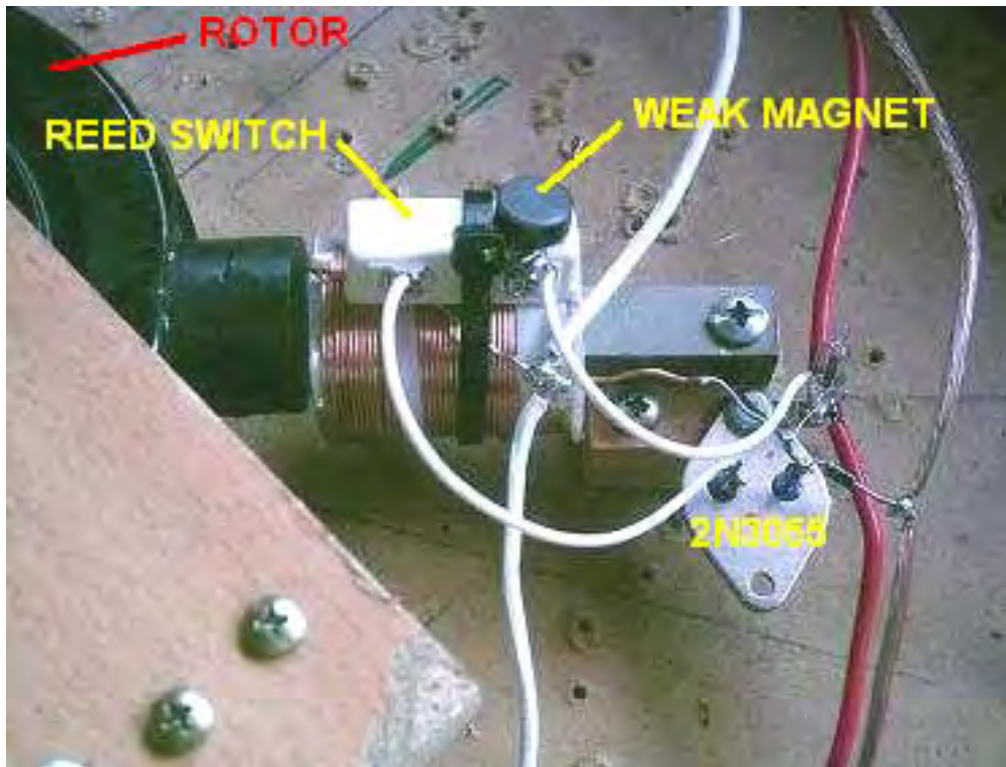

Using a very small and weak magnet, you can now control and adjust the reed switch. This allows you to adjust the switching so that the circuit oscillates continuously but still powers the passing rotor magnet. Below, is the trace across the charging battery and the battery is charging very rapidly although you are still paying for this as the input current will increase but nevertheless, you are really producing a vast amount of radiant energy for what is effectively, very little input current! Also, when you do this, the coils HISS very loudly! Yes, the coils HISS, not with a tone or frequency but with a hissing NOISE.



My prototype motor uses four of these circuit's, positioned 90 degrees apart around the rotor, and all connected in parallel. You can use just one reed switch to switch all four transistors and coils but it is more load and the reed switch does not hold up for very long. In fact, either way, if you use small reed switches, they will get worn and start to stick. I have bought larger reed switches but I am also working on an electronic switching version of this, although that is easier said than done. I have worked on this for a few months now so I have tried very many things and have not managed to match it with electronic switching yet. Limiting the current passing through the reed switch does not necessary increase the length of its operational life, besides which, doing that produces less radiant energy.

Now having shown you all this, we are only half way to a complete radiant energy system which will provide continuous free energy. The above circuit and motor, even though they do provide large amounts of radiant energy, will still only give you a COP equal to, or close to 1 when regularly swapping over between the source

battery and the charging battery. For battery swapping to work, you MUST have the second and equally important side to the system. The second side of the system is the radiant energy accumulator-converter.

Before I describe the radiant-energy accumulator-converter, I want to highlight how important it is to build and experiment with the circuit described above. Only after adjusting and watching the input current and how the charging battery charges can you truly see how these radiant energy pulses are affecting the charging battery. In terms of why it works or how it provides so much radiant energy you have to understand that if the reed switch stays closed, which will happen when they get worn and start to stick, with the 9 millihenry crossover choke solenoid coil (bought off the shelf) which I use, the transistor is turned fully on and at virtually it's lowest resistance and so the current draw is about 6 to 8 AMPS for a single coil circuit!!! It seems this is a key requirement for generating these radiant energy pulses with a transistor. You have to switch the transistor fully on at maximum current for the coil and input voltage. This is another thing the SSG does not do well. But yet, in this circuit, when the reed switch is adjusted correctly, you can get the input down to just a few milliamps if you want!

OK, now to the radiant accumulator-converter. The requirement for this appears to be because the charging battery is not very efficient at absorbing all of the radiant energy pulses. John Bedini had related this as being due to impedance matching but I am not sure of this at this stage, but impedance may be a factor. Because the charging battery does not absorb much of the radiant energy by itself, you MUST have an accumulator-converter to absorb and convert the radiant energy for the charging battery to use. Ok, that said, what is a radiant energy accumulator-converter?

A Radiant Energy Accumulator-Converter ("REAC") is nothing more than a dipole! But the larger the dipole the better! The dipole can be a battery but that is silly when we are already charging a battery. Well in that case, it is a special battery. It is a battery that is mostly composed of potential but little current. The higher the potential the better the accumulation/conversion but some current is still required to be able to pass the energy back and charge the charging battery.

There are a number of traditional dipole's that fit what is needed. There is a simple long and raised wire antenna and ground, but this will not provide enough back current to charge our battery. There is an earth-battery setup, but unless you want to put in the effort and amount of materials to raise the voltage and still have some required current this needs a lot of work and materials. Finally, I found the best compromise to be "old, dead, sulphated lead acid batteries". At this stage of my research the condition of the battery does not really matter as long as it is "dead" and sulphated. As long as they are old and dead so that they can barely light up a 12V 100ma bulb, then they will do just fine. Gee I am glad I never threw away my old dead batteries that kept piling up.

If you go down to a battery recycler or junk yard, you can buy pallet loads of old and dead Uninterruptible Power Supply ("UPS") batteries for very little cost. When I say pallet load, I mean pallet load. The bigger the bank of these you get the better. Connect them both in series and parallel so that if they were good, you would get anywhere from 48-120 volts. When connecting in parallel make sure that each 12 volt segment has an approximately even capacity in Amp-Hours. You can put this bank under your house or table or even bury them in the ground. It is no problem as you will never have to do anything to them again (as long as they are sealed). They will NOT keep running down. They are already run down. All you need them for is to use their potential as a dipole and their hidden capacity. The very small amount of current they will provide for the size of the bank due to the crystalline resistance of the sulphation is all that is needed to provide the free energy that they will convert the radiant energy pulses and feed it back into your good battery which is being charged. I believe that these sulphate crystals may indeed be the main component that is doing the radiant energy conversion for us. Now for how to connect up your 'REAC'. See the following diagram:

Radiant Energy Battery Charging System

By Ossie Callanan 2007

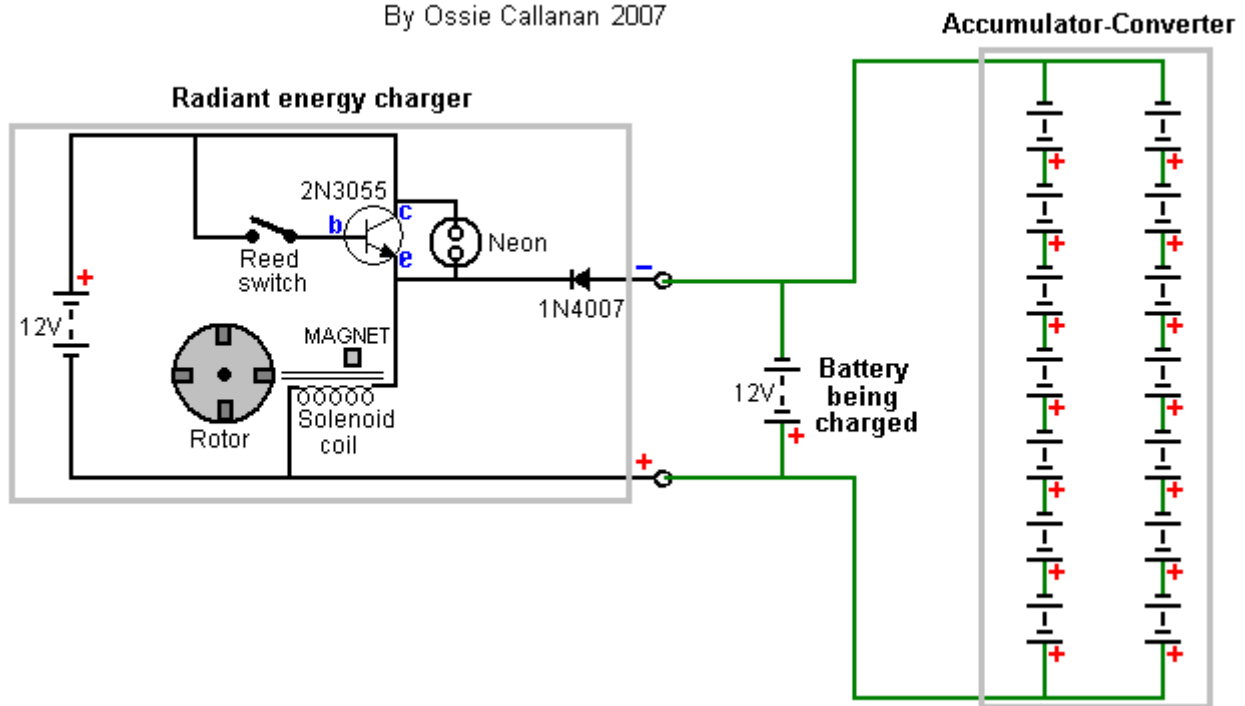

You must connect the REAC directly to the charging battery as I have shown above. Amazingly, there is a great voltage different when you measure the voltage directly across the charging battery compared to the voltage measured across the REAC while the reed motor is running. This voltage difference is seen even with thick cables connecting them, but distance does affect it as well. You must have two separate sets of cables. One set going directly from the radiant energy charger to the charging battery and the other set from the charging battery to the REAC. I have run the above setup for over one month now. Below is a picture of the "dead" batteries which I use as an REAC.



Using my good 33 Amp-Hour UPS batteries, I can charge them up from 10 volts to 14 volts in about 6 hours with the radiant energy reed motor running 4 coils drawing only 600ma. I can then swap the source battery with the charging battery and keep doing this until I have both batteries charged in about 24 hours. I have done this very many times and the charging rate appears to be improving over time.

But one thing I want to make clear. If you think that I am somehow just using the stored energy in the REAC bank, if I do not use my reed motor, then the charging battery will not charge. If I try replacing the reed motor with a regular battery charger, the battery will take as long to charge as a normal battery charger would to charge it. When using the reed motor, the REAC is converting most of the radiant energy and providing the energy back to the charging battery. There you have it, a fully working radiant free energy system. Enjoy! -- Ossie Callanan

The Self-Charging Battery Charger.

One major disadvantage of some of these battery pulse-chargers is the fact that it is thought that it is not possible to self-power the device nor to boost the running battery during the battery charging process. There is one variation of the pulse-charger which does actually boost the driving motor as it runs, and one particular implementation of this is shown here:

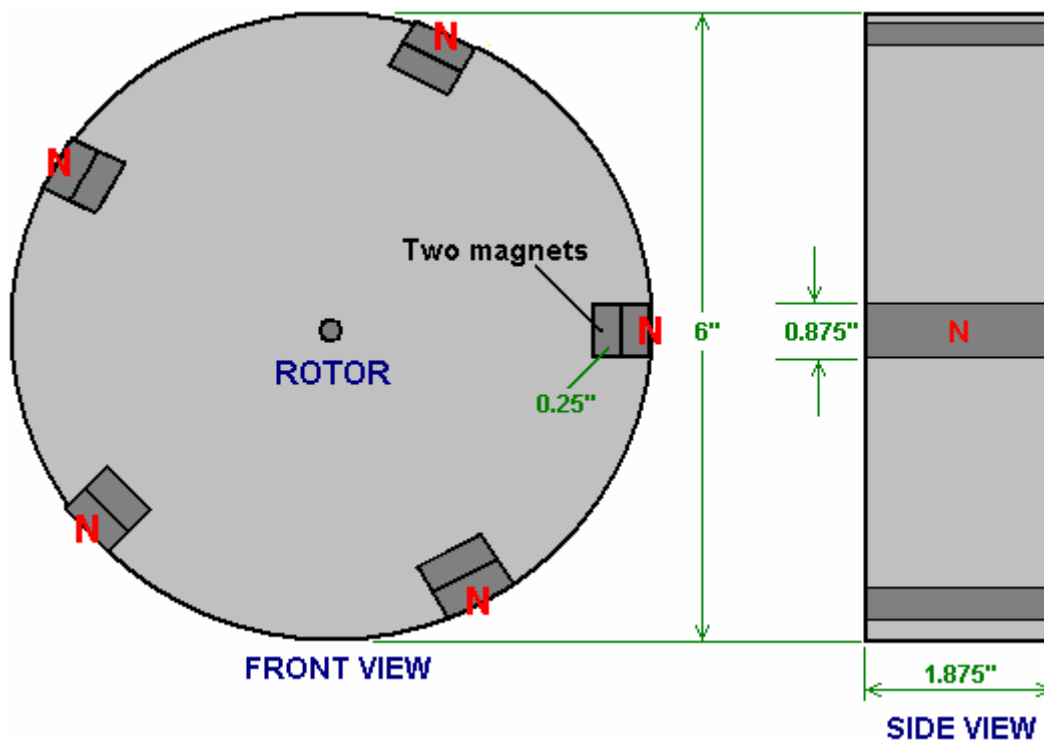

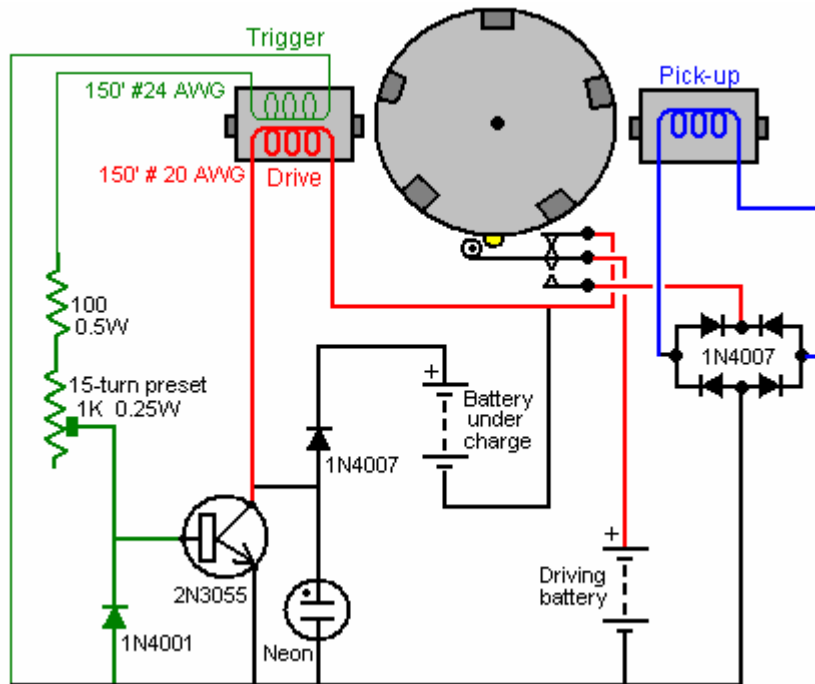

The rotor weighs about five pounds (2 Kg) and is very heavy for its size, because it is constructed from flooring laminate, and has a thickness of 1.875 inches (48 mm) to match the width of the magnets. There are ten magnets size 1.875" x 0.875" x 0.25" (48 mm x 22 mm x 6 mm) which are assembled in pairs, to produce the most evenly matched magnetic sets possible. That is, the strongest is put together with the weakest, the second most strong with the second weakest, and so on to produce the five sets, each half an inch (12 mm) thick. These pairs are embedded in the rotor at equal 72° centres around the edge of the rotor.

The battery pulsing produced by this circuit is the same as shown in John Bedini's patent already mentioned. As the rotor turns, the trigger winding energises the 2N3055 transistor which then drives a strong pulse through the winding shown in red in the diagram above. The voltage spike which occurs when the drive current is suddenly cut off, is fed to the battery being charged. This happens five times during a single revolution of the rotor.

The clever variation introduced here, is to position a pick-up coil opposite the driving/charging coil. As there are five magnets, the drive/charging coil is not in use when a magnet is passing the pick-up coil. The driving circuit is not actually active at this instant, so the micro switch is used to disconnect the circuit completely from the driving battery and connect the pick-up coil to the driving battery. This feeds a charging pulse to the driving battery via the bridge of 1N4007 high-voltage diodes. This is only done once per revolution, and the physical position of the micro switch is adjusted to get the timing exactly right.

This arrangement produces a circuit which in addition to pulsing the battery bank under charge, but also returns current to the driving battery.

Another variation on this theme is shown on YouTube where an experimenter who calls himself "Daftman" has this video explaining the circuit he uses in his Bedini-style battery-charging motor: <http://uk.youtube.com/watch?v=JJilOTsmrM&feature=channel> and his video of his motor running can be seen at: <http://www.youtube.com/watch?v=S96MjW-isXM> and his motor has been running for months in a self-powered mode.

The Relay Coil Battery Charger.

One experimenter on the Energetic Forum has posted a video of his adaptation of the Bedini circuit at <http://uk.youtube.com/watch?v=4P1zr58MVfl>. He has found that adding a 6-volt relay coil into the feed to the base of the transistor has halved the power used and yet keeps the rotor at about the same rate of rotation. The circuit is shown here:

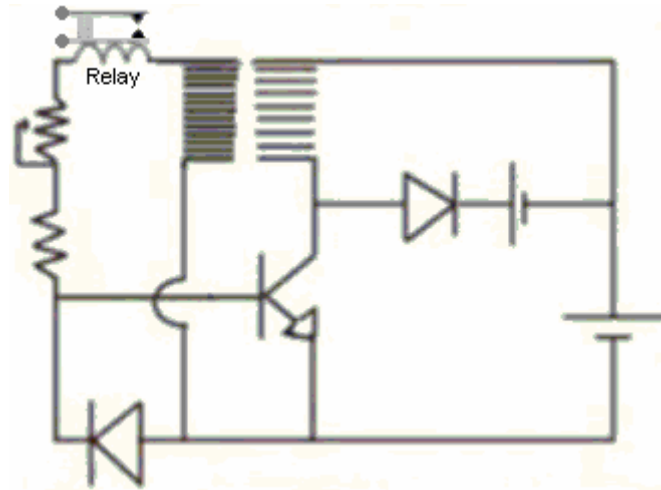

The build used has three electromagnet coils placed around a horizontal rotor:



The Modified Fan Battery Charger.

Other more simple methods of getting this radiant energy charging of batteries are also available. One simple method is to skip most of the mechanical construction and use a slightly adapted synchronous fan. This method is shown by "Imhotep" in his instructional video which is located at <http://uk.youtube.com/watch?v=eDS9qk-Nw4M&feature=related>. The original idea comes from John Bedini and the fan idea from Dr Peter Lindemann.

The most common choice for the fan is a computer cooling fan - the larger the better. These fans usually have four windings connected like this:

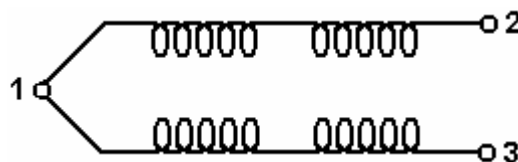

To use these windings as both drive and pick-up coils, the fan is opened up by lifting the label covering the hub of the fan, removing the plastic clip holding the fan blades on the spindle and opening the casing to expose the coils. The wire post with two wires going to it then has one wire removed and a fourth post improvised by drilling a small hole and inserting a short length of wire from a resistor. The fourth wire end is then soldered to it to give this arrangement:

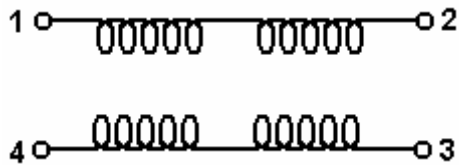

This produces two separate coil chains: 1 to 2 and 4 to 3. One can then be used as the drive coil and the other as the power pick-up coil which passes the very short high voltage pulses to the battery which is being charged.

When opened up, the fan looks like this:



And the circuit arrangement is:

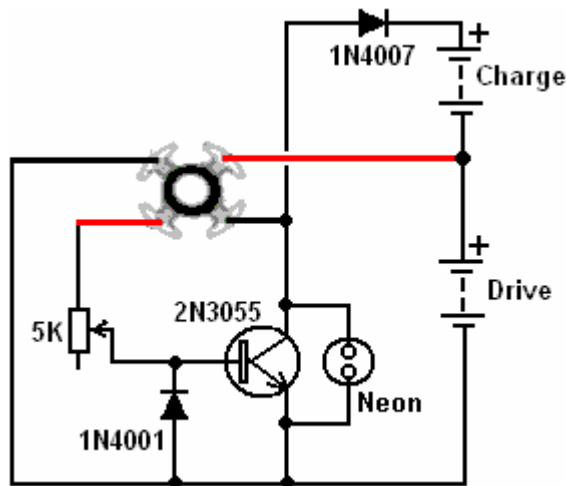

The fan is started by hand and then continues to spin, working as a fan as well as charging a battery. The current draw from the driving battery is very low and yet the radiant energy charging of the other battery (or battery bank) is not slow. Please remember that batteries which are to be used with this radiant energy, need to be charged and discharged many times before they become adapted to working with this new energy. When that has been accomplished, the battery capacity is much greater than specified on the label of the battery and the recharging time also becomes much shorter. The circuit is adjusted with the variable resistor, which changes the transistor drive current, which in turn, alters the speed of the fan. The variable resistor setting is adjusted very slowly to find the resonant spot where the input current drops to a minimum. At resonant point, the battery charging will be at it's maximum level. It should be stressed that this device and the relay charger shown below, are simple demonstration devices with small coils and to get serious charging, you need to use one of John Bedini's large-coil battery pulsing systems with a bank of lead-acid batteries being charged.

A very neat build of an 80 mm computer fan conversion to a pulse charger built by Brian Heath is shown here:



The Automotive relay Battery Charger.

An even more simple charging method is also shown by “Imhotep” in another of his instructional videos at <http://d1190995.domaincentral.com.au/page6.html>. Here he adapts an ordinary 40 amp car relay, converting it from having a “normally open” contact, to operating with a “normally closed” contact. It is not necessary for you to do this as automotive relays with “normally closed” contacts are readily available and are not expensive.

The relay is then wired up so that it powers itself through its own contacts. This causes a current to flow through the relay coil winding, operating the contact and opening it. This cuts off the current through the relay’s own coil, causing the contacts to close again and the process starts all over again.

The repeated opening and closing of the relay contacts happens at the resonant frequency of the relay and this produces a buzzing noise. Actually, buzzers were originally made this way and they were used in much the same way as a doorbell would be used today.

The circuit used is shown here:

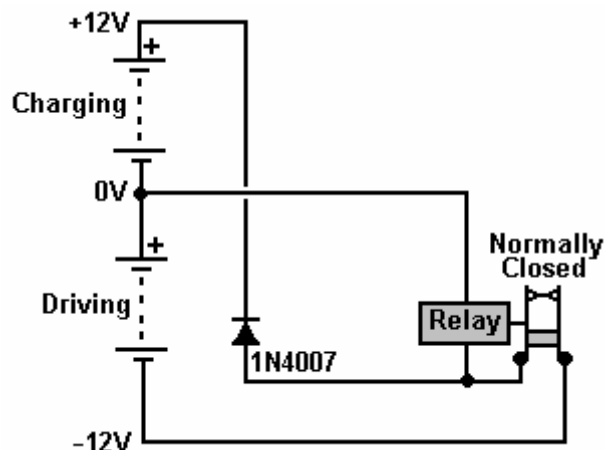

As you can see, this very simple circuit uses only two components: one relay and one diode. The key feature is the fact that when the relay contacts open and current stops flowing through the relay coil, a very high voltage spike is generated across the relay coil. In transistor circuits which drive a relay, you will see a diode wired across the relay coil in order to short-circuit this high voltage at switch-off and stop the transistor getting destroyed by the excessively high voltage. In this circuit, no protection is needed for the relay. Any number of batteries can be charged at the same time.

An ordinary 40 amp automotive relay like this:



can have a “changeover” contact, which means that it has a “normally closed” contact and so can be used directly without any need to open or modify the relay itself.

In this circuit, however, that reverse voltage is being used in a very productive way. These voltage spikes are very sharp, very short and have a very fast voltage rise. This is exactly what is needed to trigger an inflow of radiant energy from the local environment, into the battery. This battery charging current is not coming from the driving battery but is coming from the environment. The small current from the driving battery is just operating the relay as a buzzer.

One user of this circuit commented that he was using a non-automotive relay with a greater number of turns in the coil, and he found that both of the batteries were getting charged at the same time, but of course, the drive battery was gaining charge at a slower rate. This will have been because the current draw with the more efficient relay was less than the rate of charging and so, even the drive battery gained power.

Please remember that at this time, we have no instrument which can directly measure the flow of radiant energy into the charging battery. The only reliable way of assessing the inflow is to see how long it takes to discharge the charged battery through a known load.

My experience with using relays for battery charging indicates that you get a better result if 24 volts is used to drive the circuit and as vehicle relays don't have that much of a coil winding, there is a considerable improvement if a large coil is connected across the relay coil or coils as shown here:

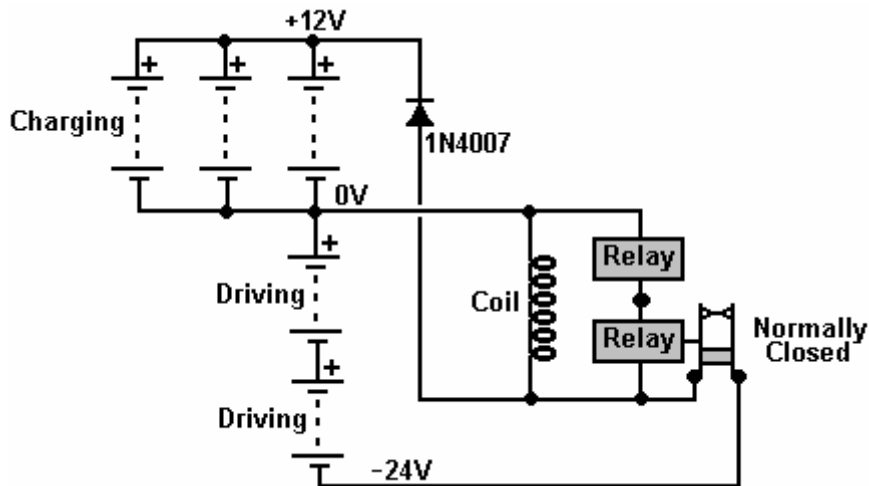

When using one of these relay charging systems you will find that quite a lot of noise is generated. This can be reduced quite easily with a little padding and it does have the advantage of indicating that the charging system is running correctly.

The Self-Charging Motor.

A video at <http://www.youtube.com/watch?gl=GB&v=AWpB3peU3Uk&hl=en-GB&feature=related> shows an interesting home-built device which uses the motor out of an old video recorder, the bearing out of an old computer CD drive and pick-up coils made by removing the case and contacts from standard relays:

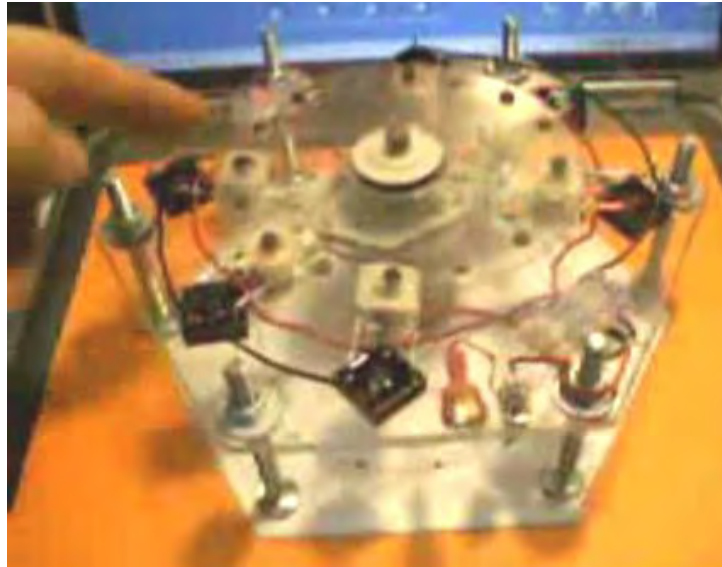

The construction is very straightforward with a simple, uncluttered, open layout:

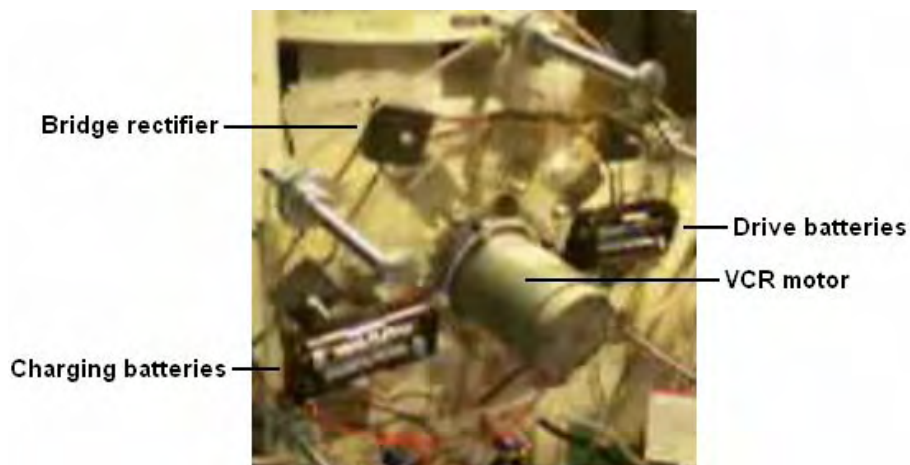

With this arrangement, one pair of AA-size NiCad batteries drives the motor, spinning the motor, moving its magnets rapidly past the ring of converted relays, producing charging DC current via the bridge rectifiers and that current is sufficient to keep the device running continuously.

A comment made on the video is that if the ferrite magnets were replaced with neodymiums, then the charging voltage rises to around 70 volts. Unfortunately, the present rotor is too flexible and the neodymium magnets actually flex the rotor down towards the relay cores as they pass, so a more robust rotor is needed.

The 'Alexkor' Solid-State Battery Charger Circuits.

The "Alexkor" battery-charging system is very effective, cheap and easy to build. It is a version of the system described in Fig. 22B on page 7 of the <http://www.totallyamped.net/adams/> web page:

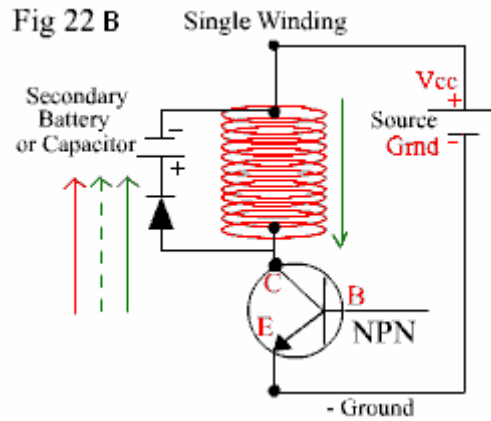

While this description has been around for years, it is part of a discussion on the principles of the operation of EMF magnetic fields and pulsing in coils. 'Alexkor' has developed a practical circuit which he says works very well. It can be constructed as a single unit as shown here:

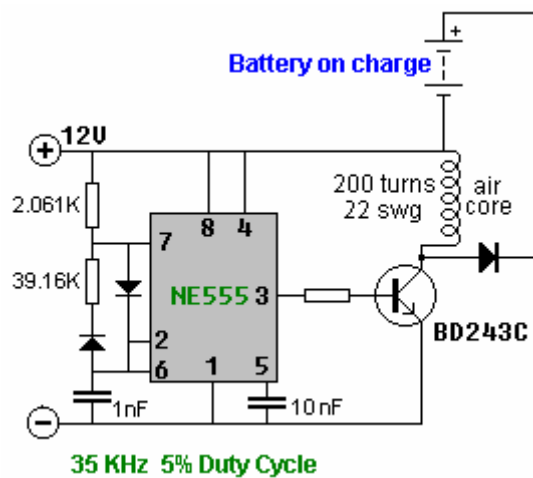

Here, the coil is wound with 200 turns of 0.7 mm enamelled copper wire and the actual construction is compact:

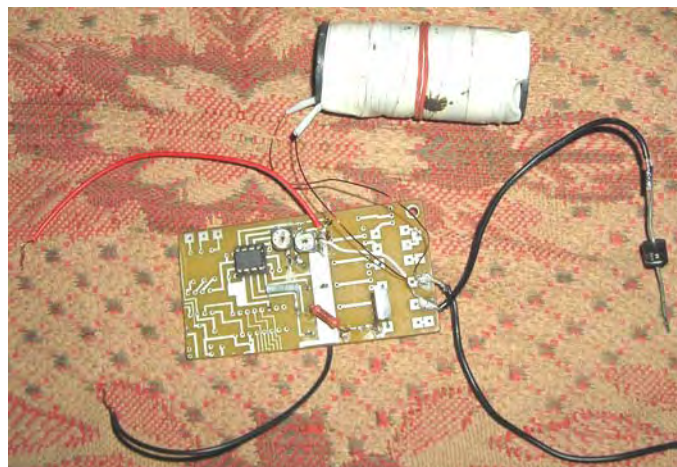

And to get an idea of the performance, Alex uses a capacitor to see the size of the voltage spikes produced by the circuit:

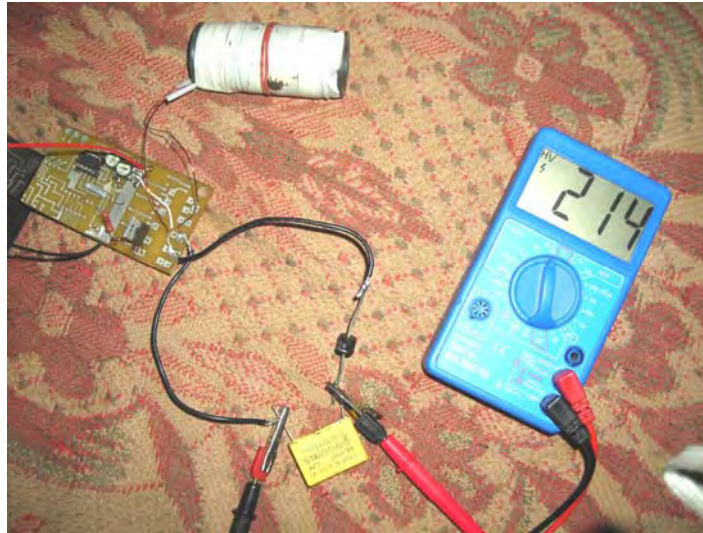

This is the first step in the process as the same circuit can be used to drive many coils of this type. The resistor feeding the base of the transistor is about 500 ohms for the prototype, but using a 390 ohm resistor in series with a variable resistor of say, 1K, would allow a good standard resistor value to be selected for each transistor/coil pair:

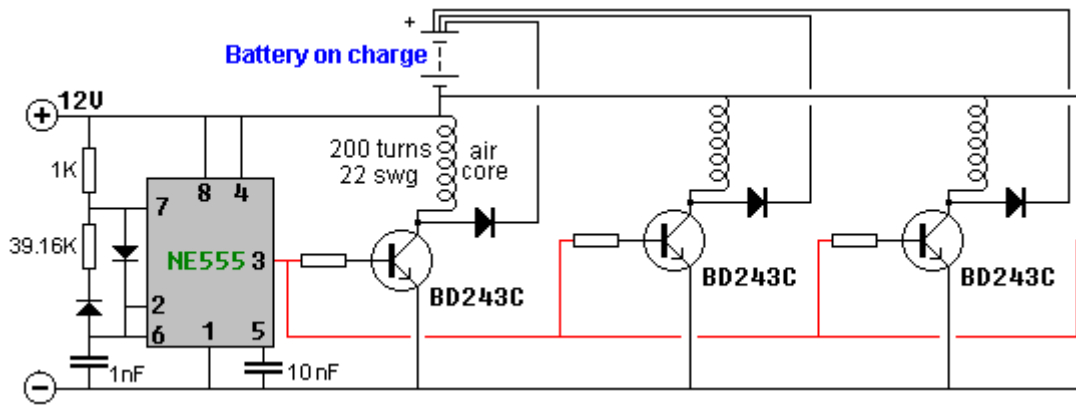

As can be seen from the photographs, Alex uses preset resistors to adjust the settings to their optimum values. The simplicity of this circuit makes it very attractive as a construction project and using more than one coil should make for impressive performance figures. Alex says that the best results are achieved with just the one (1000V 10A) diode and not a diode bridge, which is borne out by the teaching comments on the above web site. Multiple transistor chargers like the one above, work best when there is a separate wire from each coil to the battery being charged.

Further development by Alex shows better performance when using the IRF510 FET instead of the BD243C transistor. He also has found it very effective charging four separate batteries and he has revived an old NiCad drill battery using this circuit:

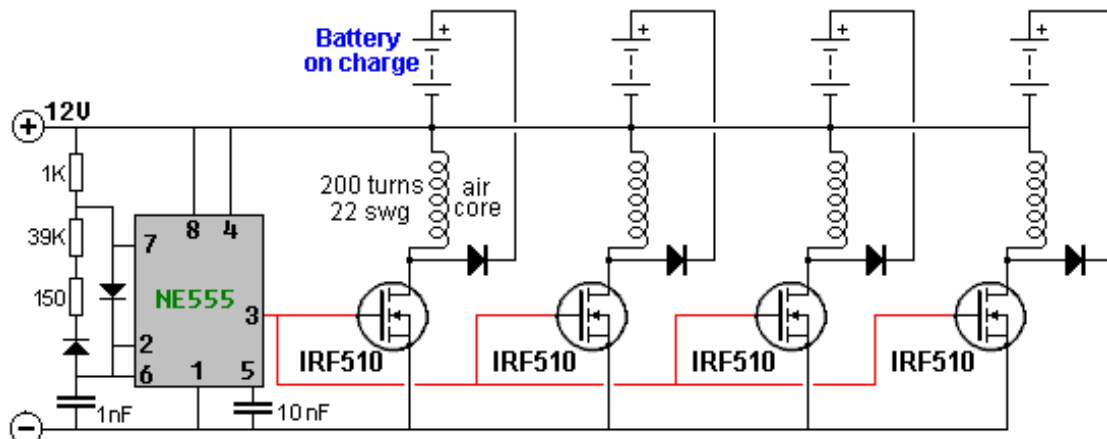

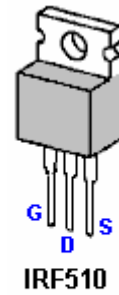
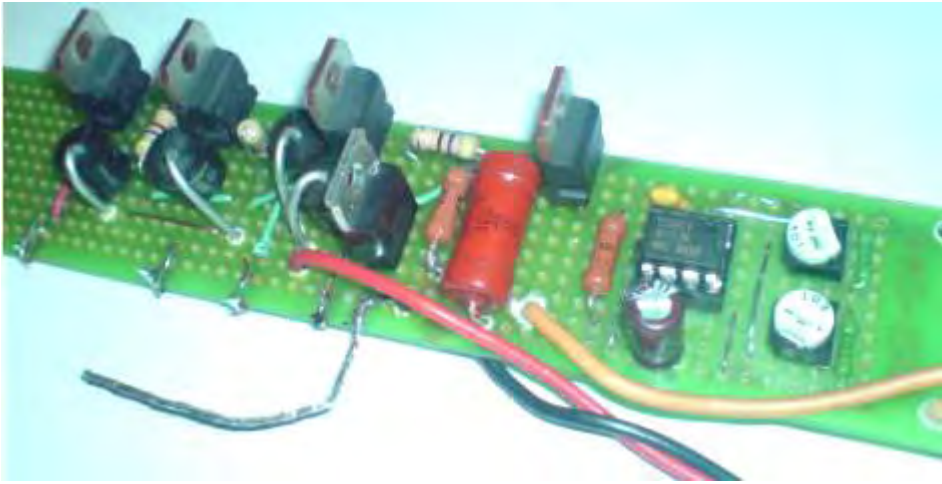

It is possible to use various different transistors with these circuits. As some people have difficulty in working out a suitable physical construction for a circuit, here is a suggestion for a possible layout using an MJ11016 high-power high-gain transistor on stripboard.

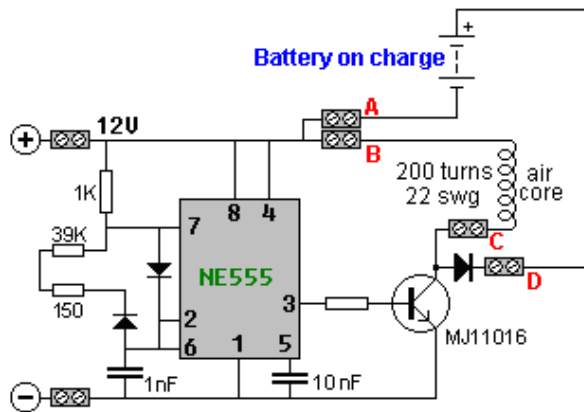

⊗ = break in the copper strip

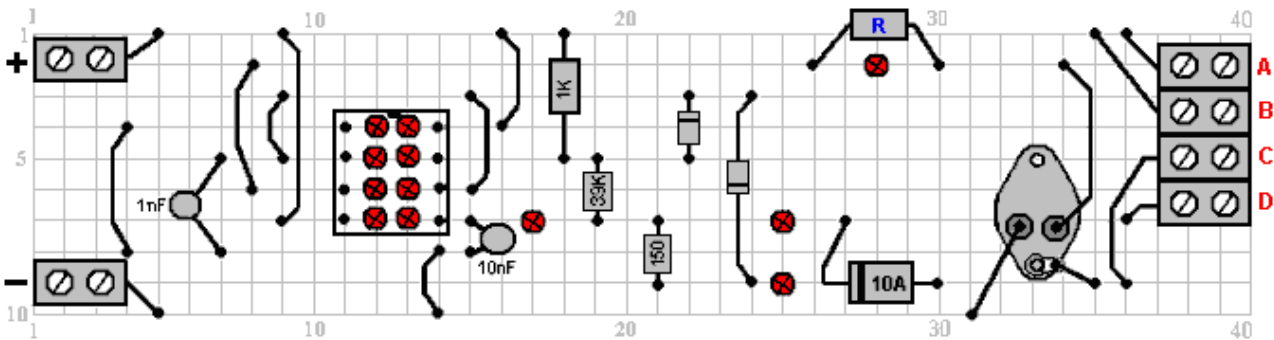

Alexkor's Self-Charging Circuit.

This is a particularly simple circuit which allows a 12V, 8 amp-hour battery charge a 48V, 12 amp-hour battery with radiant energy, in 20 hours using twelve times less current than a conventional charger would. The circuit can charge lithium, NiCad or lead-acid batteries. The circuit used is:

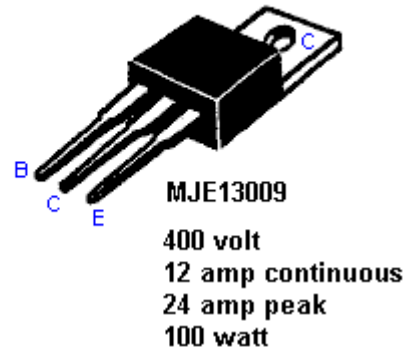
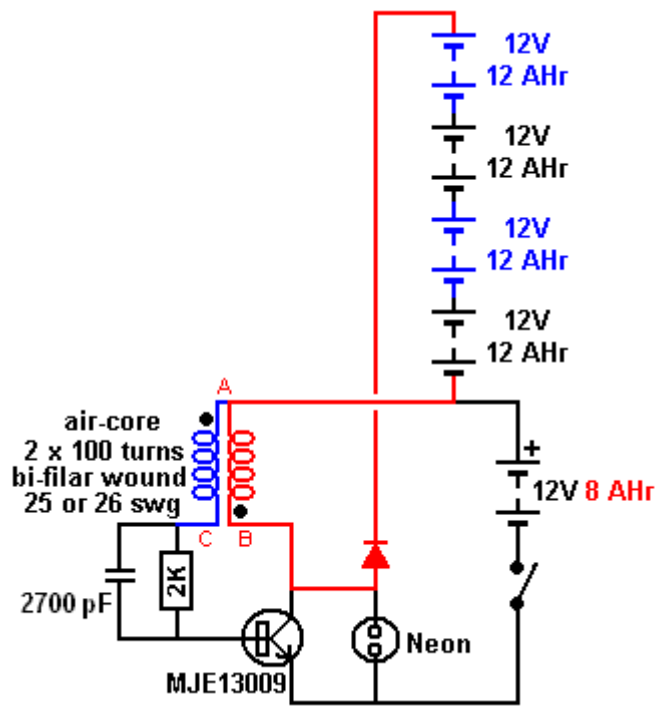

The coil is wound on a hollow former, using two separate strands of wire of 0.5 mm diameter, giving a resistance of just 2 ohms. The strands of wire are placed side by side in a single layer like this:

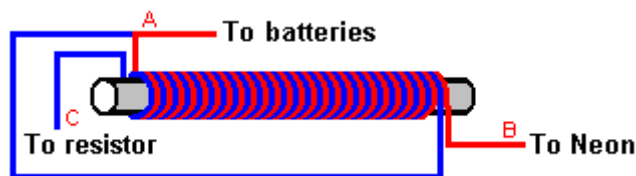

A possible physical layout using a small standard electrical connector strip might be:

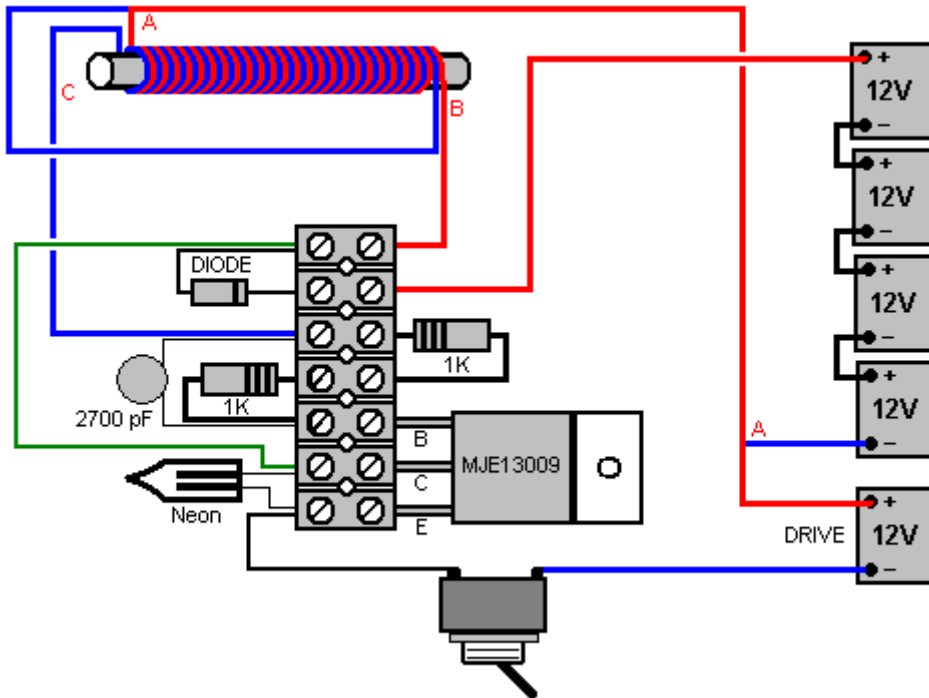

If the coil is wound on say, a 1.25-inch or 32 mm diameter plastic pipe, then the outside pipe diameter is 36 mm due to the wall thickness of the plastic pipe, and each turn takes about 118 mm, so around 24 metres of wire will be needed for the 200 turns. If 13 metres (14 yards) of wire is measured off the spool and the wire folded back on itself in a sharp U-turn, then the coil can be wound tightly and neatly with close side-by-side turns. A small hole drilled at the end of the pipe allows the folded wire to be secured with two turns through the hole, and the 200 turns will take up a length of about 100 mm (4-inches) and the two loose ends secured using another small hole drilled in the pipe. The starting ends are cut apart and the ends of each coil determined using a continuity test.

An even more advanced circuit from Alex has even higher performance by using a high-speed transistor and a very fast-action diode, and a neon is not needed to protect the transistor:

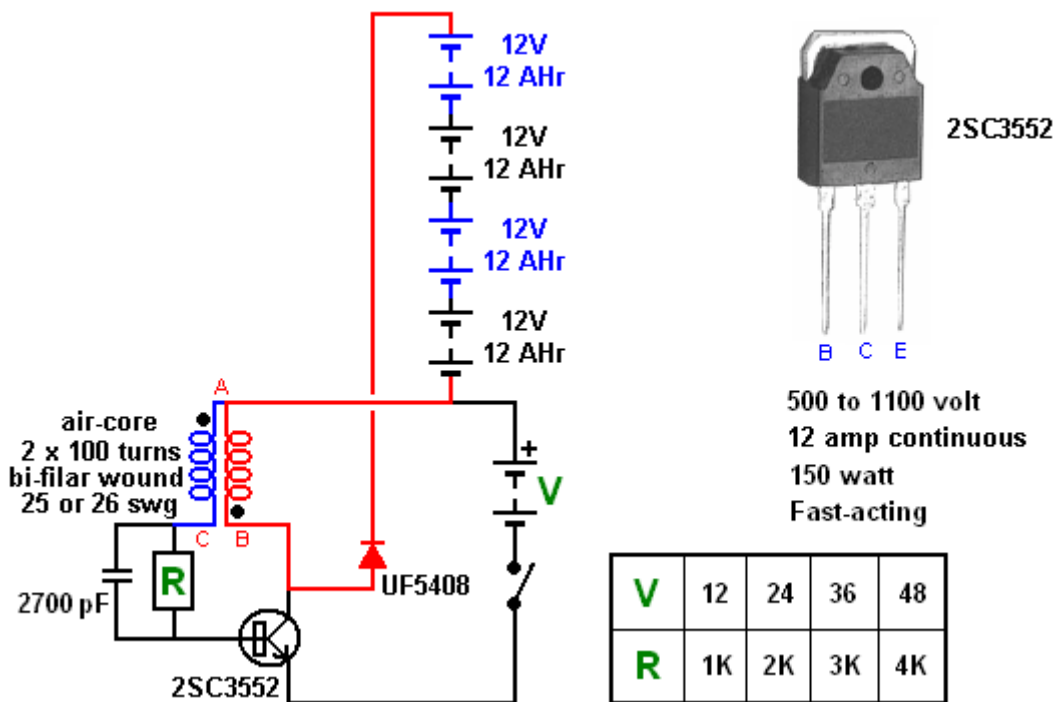

The fast UF5408 diode used in this circuit is available, at the present time, on www.ebay.co.uk in packs of 20 for £3.84 inclusive of postage.

The transistor drive to the battery bank can be replicated for additional drive and an additional ten transistors could be used like this:

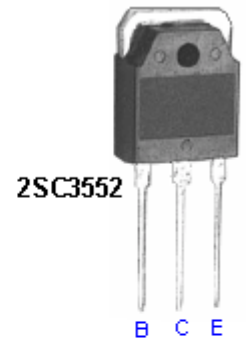
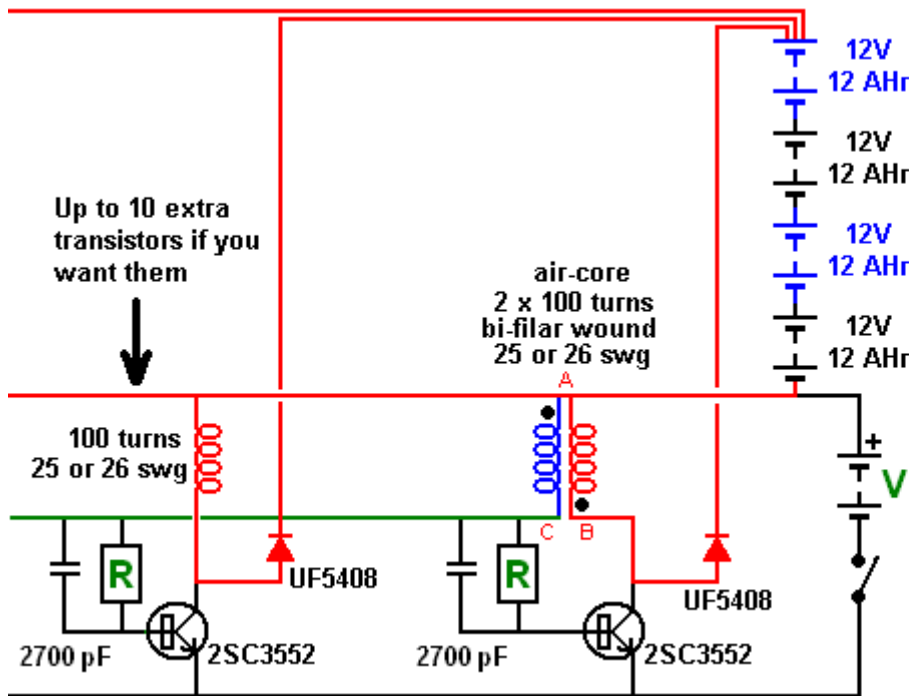

500 to 1100 volt
12A continuous
150 watt
Fast-acting

V	12	24	36	48
R	1K	2K	3K	4K

The 2700 pF capacitor is recommended for each additional transistor, but it is not an essential item and the circuit will operate ok with just the one on the bi-filar coil drive section.

A recent circuit design from Alexkor uses the tiniest of inputs; just 1.5 volts at a current which can be adjusted down from 4 milliamps to just 1 milliamp. This tiny circuit can charge a 12-volt battery, although admittedly, the charging rate is not very high as it takes ten hours per Amp-Hour to charge the battery. However, it is spectacular to get a input of just 1.5 milliwatts to charge a 12V battery. The circuit has very few components:

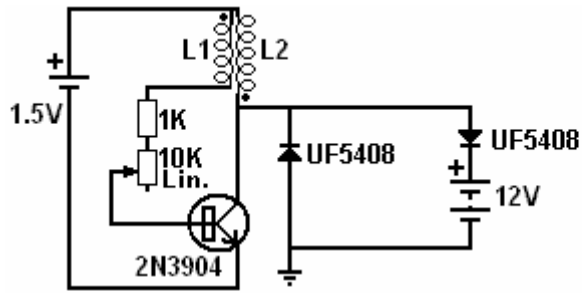

Coils: 0.5 to 1.0mm diameter solid copper wire length: 1 to 2 metres bi-filar wound

Variable resistor adjusted for minimum current 1 to 4 mA
Output is 40V spikes

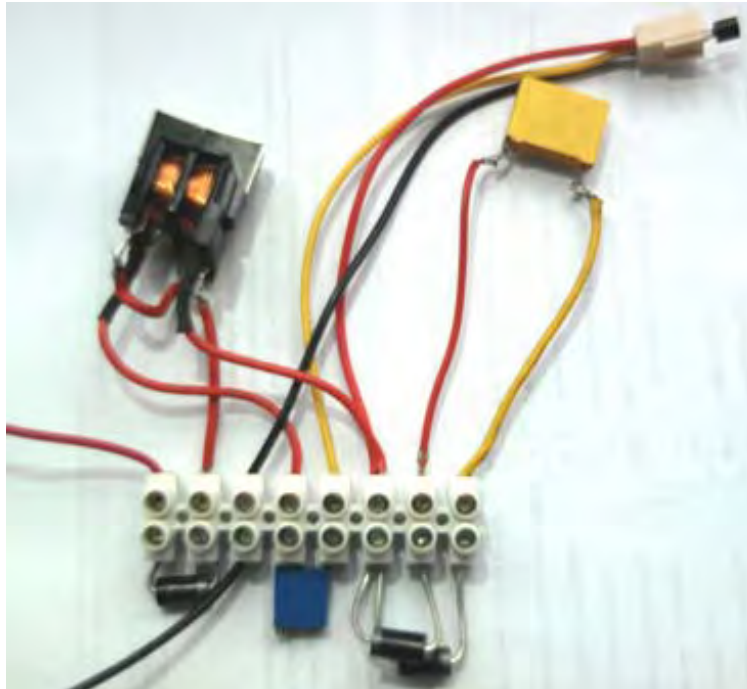

The coil is tiny, bi-filar wound on ferrite or with an air-core. In the circuit diagram, the dots on the coil windings indicate the start of the two side-by-side windings. This makes it clear that the start of one winding is connected to the end of the other winding as well as to the positive side of the 1.5V battery. The variable resistor could be omitted and various fixed resistors tried until the 1 milliamp current level is reached. It should be emphasised that there is just one earthing point and it is a real connect-to-the-ground type of connection. Simple arithmetic will show you that if there is a charging current flowing into the battery to charge it, then even with an imagined 100% efficiency of the battery, the battery charge is many times greater than the draw from the battery driving the circuit. The circuit runs at a frequency between 200 MHz and 300 MHz.

Alex uses a commercial “choke” from http://it.farnell.com/murata/pla10an1522r0r2b/choke-common-mode-2x1-5mh-2-0a/dp/9528423?whydiditmatch=rel_3&matchedProduct=3532290 as shown here:

Type	PLA
Execution	with a single rail
Rated current, a	2
Rated voltage, v	300
Winding inductance, mH	1.5
Active resistance, Ohm	1500
Hull length, mm	18



Jes Ascanius of Denmark has replicated this circuit and he makes these comments: The 10K variable resistor and the additional 1K resistor need to be 250 mW types as larger wattages cause a greater current draw. Also, the quality of the earth connection is important as his very efficient earth produces 60-volt pulses from the circuit (70-volts at night) and just by touching the earth connection can boost those pulses right up to 92-volts and so further experimentation may produce some other interesting effects.

Alexkor’s most advanced circuit to date is the one shown here:

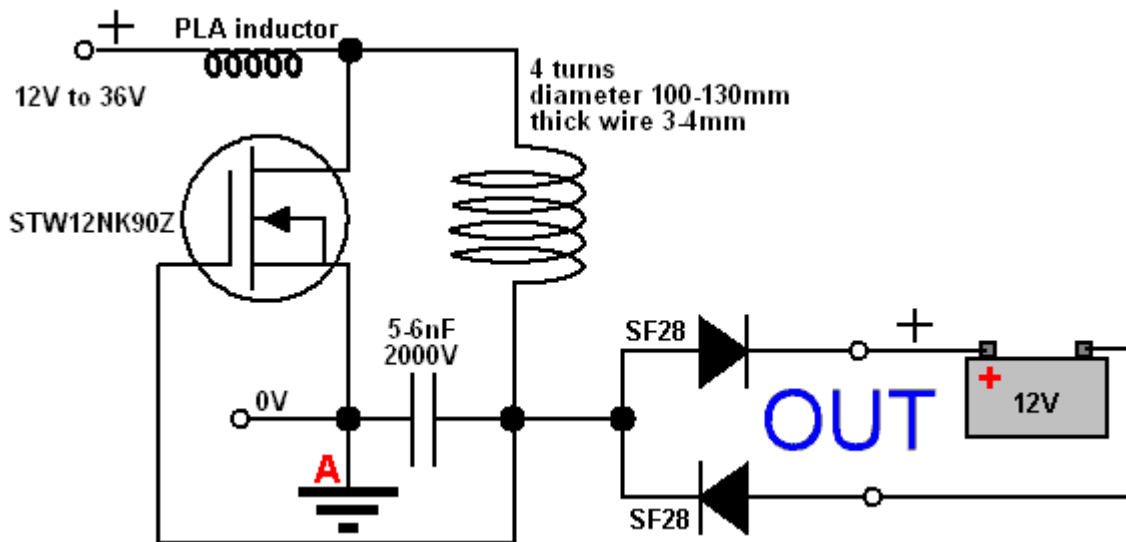

This circuit uses the PLA inductor shown above. The initial reaction of somebody familiar with electronic circuits might well be “this is impossible as the battery being charged is ‘floating’ as it is not connected to either side of the driving battery”. While that is true, the circuit works very well indeed and a battery bank of ten 1.2V Ni-Mh batteries rated at 1100 mAh capacity which had been charged and discharged ten times before, is now charged by this circuit in just half an hour.

The input voltage can be anything from 12V to 36V without the need to change any of the circuit components. The choice of transistor is important and the STW12NK90Z is a very high-performance, high-voltage transistor (available at the present time from www.mouser.com), and while it is not cheap, I would strongly recommend its use if you decide to replicate this circuit. The SF28 diodes are also special components, rated at 600 volts and 2 amps, these are high-speed diodes, not to be replaced with any diode which happens to be available.

The coil is most unusual in that it is just four turns of very thick copper wire, 3 mm to 4 mm in diameter, although aluminium wire can also be used. This power cable is wound on to a spool of 100 mm to 130 mm (4-inch to 5-inch) diameter. The tiny 5 nF capacitor needs to be rated at a very high 6000 volts. The real Earth connection at point “A” gives a 20% to 30% improvement in performance but if the circuit has to be portable, then it will work with the lower level of performance if the earth connection is omitted and point “A” is connected to the 0V line of the input battery.

While the coils shown above are air-core to allow high frequency operation, coils, most other coils are generally much more efficient with some form of magnetic core, such as iron-dust or ferrite. While it is not likely to be able to operate at frequencies as high as 35 KHz, a very good material for coil cores is the metal of masonry anchors or “sleeve anchors” which look like this:

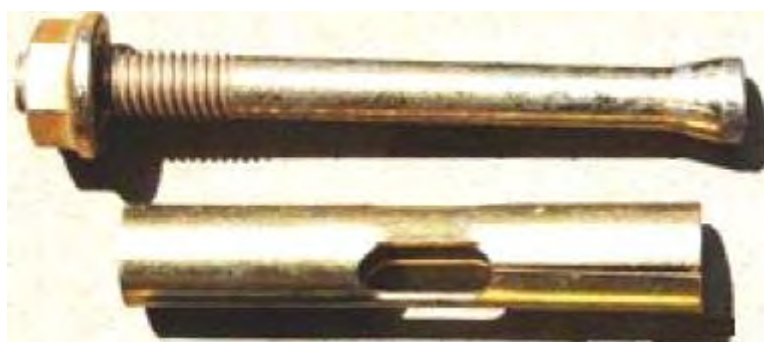

This metal is immune to rusting, easy to work and loses all magnetism as soon as the magnetic field is removed. You can confirm this for yourself by placing a permanent magnet on one end of the bolt or the tube and using the other end to pick up a steel screw. As soon as the permanent magnet is removed, the screw falls off as the metal does not retain any of the magnetism from the permanent magnet. These anchors are cheap and readily available from builder's supplies outlets, including those on the internet. It is unlikely that this material could operate at more than 1,000 Hz and the circuit above gains a lot of its performance from the high speed, fast switching and very short “On” time duty cycle.

If you use the bolt section of one of these anchors, the conical bump at the end of the shaft will have a delaying effect on the build-up and release of the magnetic field and so it might be advisable to either file it down gently by hand, or to cut off the conical section. There will always be eddy current losses in any solid metal core, but that does not stop them being very effective in operation. As with everything else, testing an actual device is the key to good performance and sound knowledge.

Howard Halay's Battery Charging Techniques

Howard Halay of the UK stresses the major difference between "conditioned" batteries and all batteries which have not been conditioned. He says: to condition a battery or capacitor, it needs to be repeatedly charged with 'cold' electricity and discharged again. Cold electricity is either high frequency AC electricity or alternatively DC at high voltage. With cold electricity, the electricity flows outside the wires (Steinmetz) and so, Current does not equal Voltage divided by Resistance as Ohm's Law suggests. Instead, Current equals Voltage x Resistance x a Constant "C" which has to be determined by experimentation. It is also possible to get cold electricity from pulsed DC, provided that the DC voltage is over 80 volts. If using that technique, then the sharper and faster the pulses, the better.

When you first pulse an AC or DC capacitor, it behaves normally. After approximately 12 hours of continuous pulsing a change occurs in the behaviour of the capacitor. In the case of the water capacitor, it develops a nano coating on one side only. When measured with a resistance meter it shows no resistance at all. One can say that one side becomes quasi superconducting. In the case of an ordinary capacitor, there is no reason to believe that it behaves differently. The capacitor also charges much faster than before and when the power source is switched off it continues charging! Yes you read that correctly. In my case it fires pulses for up to 3 minutes after the power is switched off, which is why they are dangerous. The firing decays exponentially although I haven't yet tabulated it scientifically – I'll leave that to other people to do.

The result of this is that you can have two identical capacitors side by side. One behaves as if it is plugged into a charger, while the other capacitor behaves normally. All capacitors self-charge to a certain extent but "conditioned" capacitors are in a league of their own! I have tested a neon on a conditioned capacitor through two earth rods 10 feet apart. I gave up looking at the lit neon after half an hour!

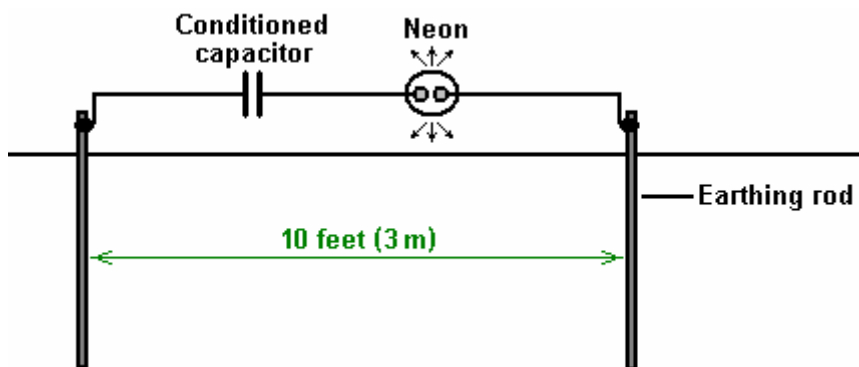

I use a very low-powered high-voltage source with a power output of only 1.2 watts as I like to play safe with these things. With a low power source, I have charged batteries using pulses of up to 800 volts without the batteries showing any ill effects. Also, using one-wire electricity is safer as that transmits mostly voltage and so minimum current is fed. So, to condition a battery or a capacitor using cold electricity, you can use a circuit like this:

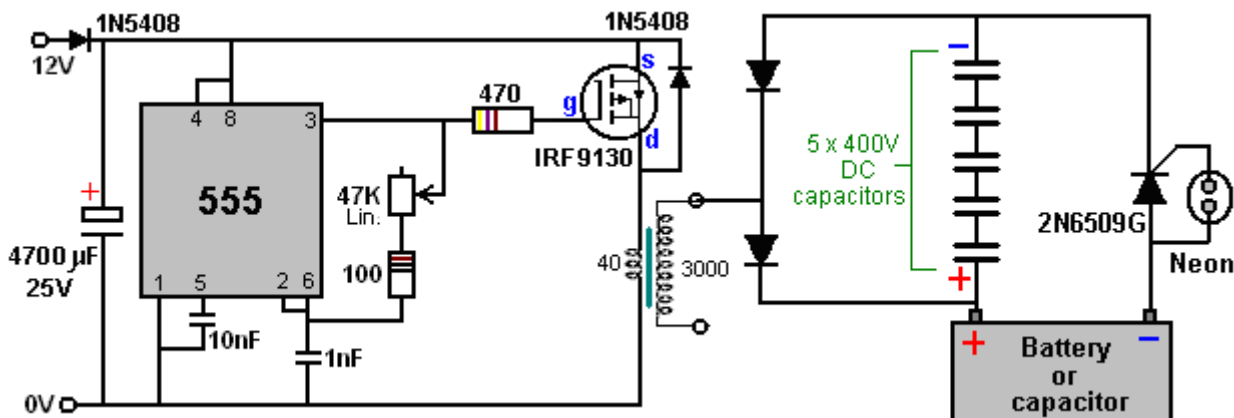

Here, the size of the voltage pulses fed to the battery or capacitor to be conditioned, is controlled by the strike voltage of the neon. The ordinary NE2 type neon lamps strike around 90V and so the 2N6509G SCR will feed pulses of about that voltage to the battery or capacitor. If two neons are connected in series and used instead of the single neon shown above, then the voltage pulses will be around 180V. This type of circuit appears to work better if several capacitors are used in series as shown here, as they seem to charge up faster and discharge faster as well. You have to leave the device running for a day to get the full benefit. I regularly charge a 1.6 Kw car battery bank, and after switching off, the battery bank voltage goes up!!

I have also tried 5 seconds of ON time and two minutes of OFF time, and the capacitors continue firing pulses. However the rate of firing is much less when the power is off than when the power is on. If you fail to use the capacitors for a while - in my case it was three weeks or so - you have to start the conditioning process all over again. In my case conditioning them again was harder and seemed to take days rather than hours. The capacitors are COLD. The wires leading up to them and out of them are COLD, but if you get a shock from them, then that shock is HOT !!

Because this charging process uses cold electricity, non-rechargeable batteries can be charged this way. In my case two out of three batteries recover their charge OK, and curiously they charge to a much higher voltage than their rated value. The battery can be replaced with a capacitor. Obviously, any battery or capacitor which is to be conditioned, needs to have be able to be charged with a voltage of not more than 70 volts per neon, so for example, a 96V battery bank would need two neons in series across the SCR of the charging circuit. This circuit will keep on charging the battery for up to three minutes after the input power is switched off. An even more powerful version of the circuit boosts the cold electricity power by using a choke. The neons will light much more strongly. The neons should pulse or you've got a short-circuit. In other words, if the neon(s) is lit continuously, it is a bad sign.

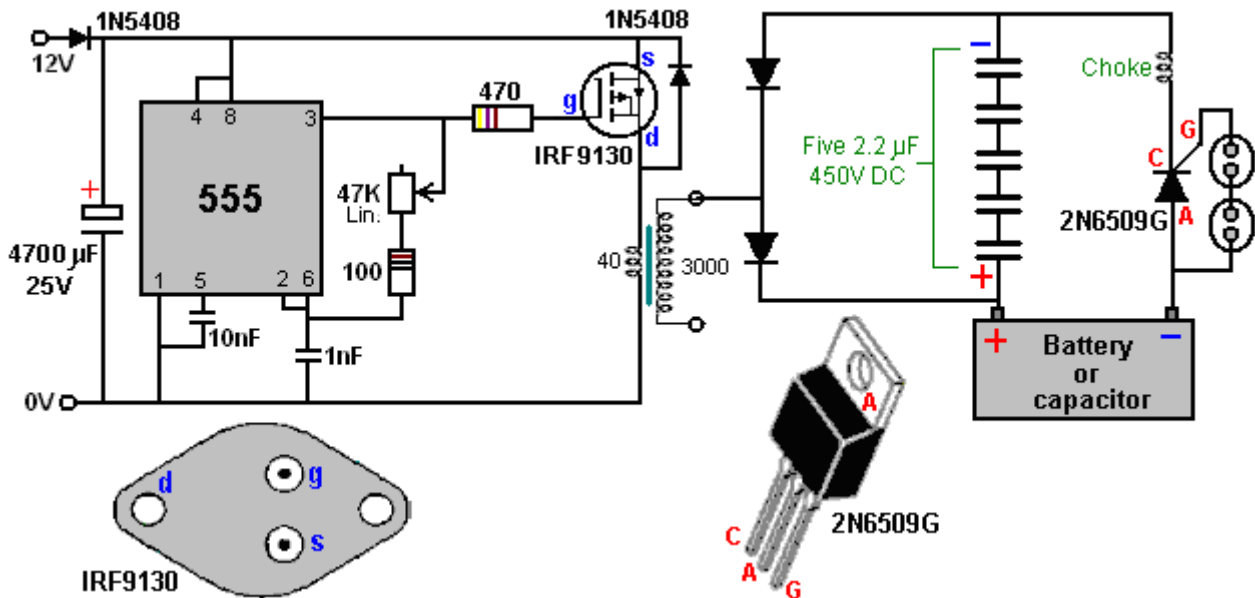

You can use a variable resistor in series with the input power to vary the pulse rate. Negative radiant energy is delivered which produces cold electricity and conditions all capacitors in the output section of the circuit.

Be very careful with this circuit as it can kill you. This circuit is only for experienced experimenters. Capacitors will take about a day to get conditioned. This circuit is good for bringing dead car batteries back to life. When a battery is conditioned and the charging circuit input power is switched off, the battery will continue charging ! Once they are conditioned, you can charge 4 car batteries in parallel using just a 6 watt 12 volt power supply, or a solar panel. However, this description must not under any circumstances be considered to be a recommendation that you should actually build this circuit as this presentation is for information purposes only.

The Ron Cole One-Battery Switch.

The following circuit is unproven as far as I am aware, but it is an interesting idea. Also, I am not sure if the idea came from John Bedini or from Ron Cole. It has the potential advantage of being a battery charger which operates on its own driving battery. It may also be possible to operate it while it is powering a load. At this time, this is not a fully tested circuit, so please treat it as an idea for experimentation if you are so inclined.

The idea is to use two capacitors which are charged up to the battery voltage and then suddenly connected together to apply twice the battery voltage to the battery. The idea is that the sudden pulse may be sharp enough

to cause an inflow of radiant energy from the local environment. To be successful, that energy inflow has to be greater than the current draw of the circuit and the capacitors. The circuit is essentially like this:

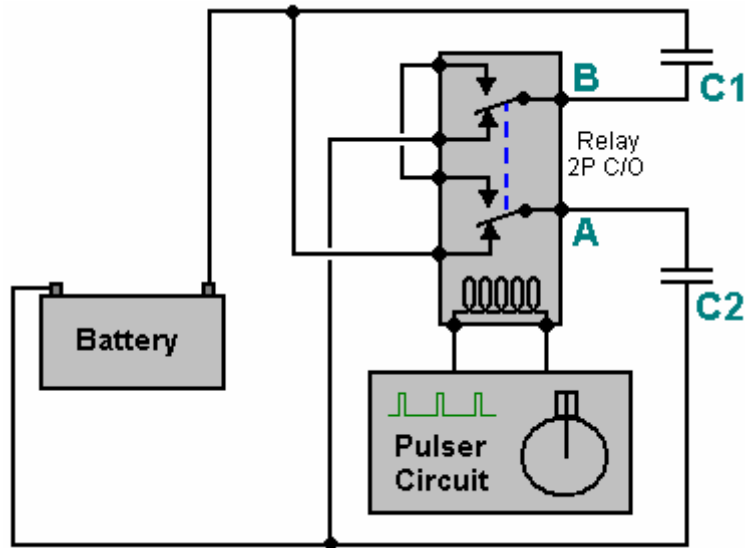

Here, the pulser circuit is set to give short, very sharp pulses to drive the relay cleanly. The relay has two changeover contacts “A” and “B”. The operation is very simple. Initially, the capacitors “C1” and “C2” are charged up when the relay is in it’s unpowered state and no current is flowing through the relay coil:

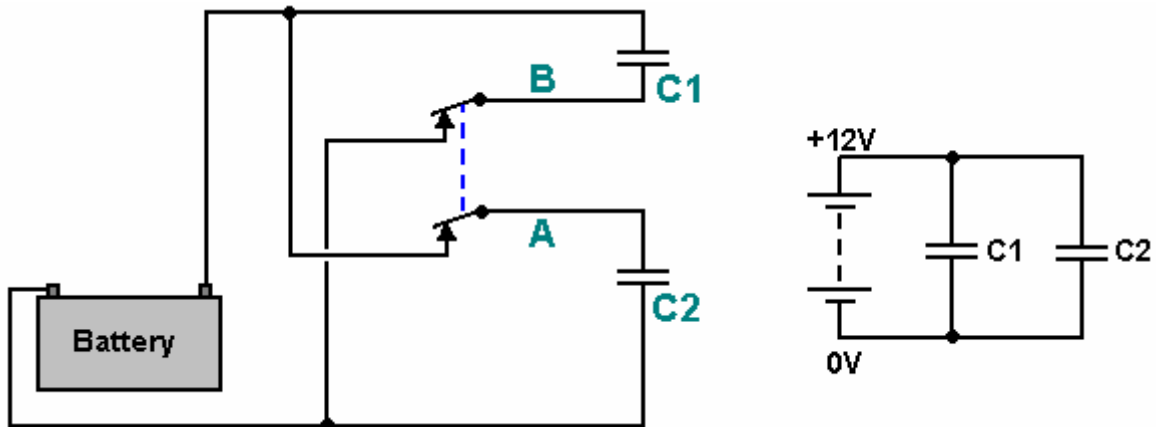

As you can see, the “normally closed” relay contacts have each of the capacitors connected directly across the battery supply rails. This gives the circuit shown above on the right. When the relay is powered up, the situation changes very suddenly to give this arrangement:

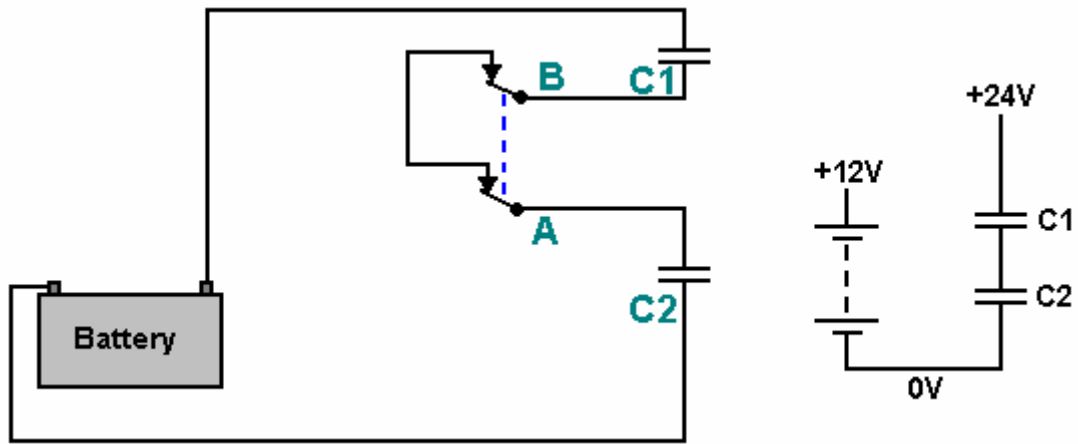

Here, the two charged capacitors are disconnected from the opposite supply rails and connected together to form a combined voltage of, in the case of a 12 volt battery, 24 volts connected across the 12 volt battery. This will cause a sudden inflow of current into the battery. However, before practically any capacitor current has flowed, the relay is operated again, repeating the sequence.

The Tesla Switch.

The Tesla Switch is covered in more detail in Chapter 5, but it is worth mentioning it again here as it does perform battery charging. The similarity ends there, because the Tesla switch does the battery charging while the circuit is providing serious current into a load. Also, the Tesla switch uses only four batteries, and still is capable of driving a thirty horsepower motor, which is the equivalent of 22 kilowatts of electrical power.

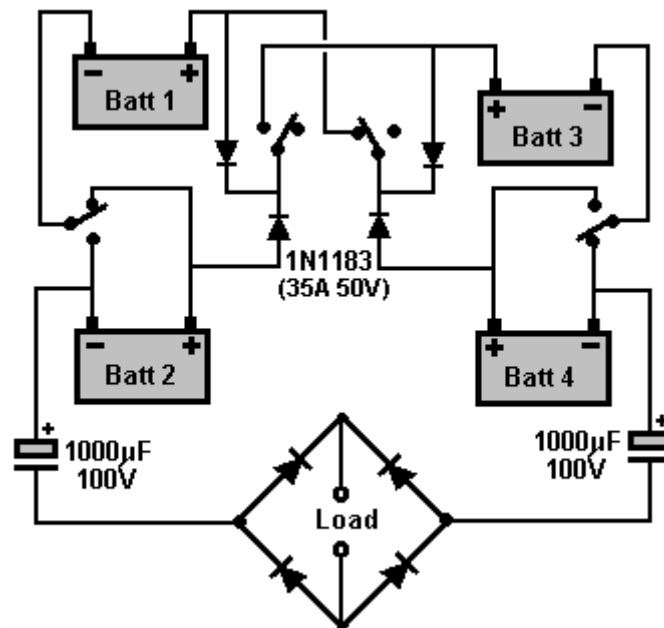

The simple circuit shown here was used by testers of the Electrodyne Corp. over a period of three years using ordinary vehicle lead-acid batteries. During that time, the batteries were not only kept charged by the circuit, but the battery voltage climbed to as much as 36 volts, without any damage to the batteries.

If the voltage on a battery under load actually increases, it is reasonable to assume that the battery is receiving more power than that delivered to the load (a load is a motor, a pump, a fan, lights, or any other electrical equipment). As this is so, and the circuit is not connected to any visible outside source of energy, it will be realised that there has to be an outside source of energy which is not visible. If the circuit is provided with powerful enough components, it is perfectly capable of powering an electric car at high speeds, as has been demonstrated by Ronald Brandt. This indicates that the invisible source of outside energy is capable of supplying serious amounts of additional power. It should also be remembered that a lead-acid battery does not normally return anything like 100% of the electrical energy fed into it during charging, so the outside source of energy is providing additional current to the batteries as well as to the load.

So, how does this circuit manage to do this? Well, it does it in exactly the same way as the battery pulse-charging circuits in that it generates a very sharply rising voltage waveform when it switches from its State 1 to its State 2 (as shown in detail earlier). This very rapid switching unbalances the local quantum energy field, causing major flows of energy, some of which enters this circuit and powers both the circuit and the load. Although it does use four batteries, and the batteries do get charged through the generation of sharp pulses, this is not a circuit which charges massive battery banks so that they can power a load at some later time.

The Self-charging Motor

It is possible to enhance the performance of a DC motor by attaching sets of neodymium magnets to the outside of the body of the motor. One example of this is shown in a video at http://www.youtube.com/watch?v=NoLbphJkxMM&list=LLlpt7ksyRVQi3ITZwSeQxaw&feature=mh_lolz shows such an arrangement and the video at <http://www.youtube.com/watch?v=5Xv-req4U8U&feature=related> shows how the motor can be set up to produce this enhancement of it's performance. The motor looks like this:



And a frame is used to hold four sets of bar magnets in position around it:



The frame is made from two pieces of 3 mm aluminium with plastic spacers holding the two aluminium discs apart. The plastic spacers are secured with brass screws. As the motor casing is about 3 mm thick steel, that tends to deflect the added magnetic field outwards, which is the reverse of what is wanted. So, a 6 mm thick strip of steel is placed outside the magnets in order to direct the field inwards. The magnets and steel strips are then inserted to complete the arrangement:

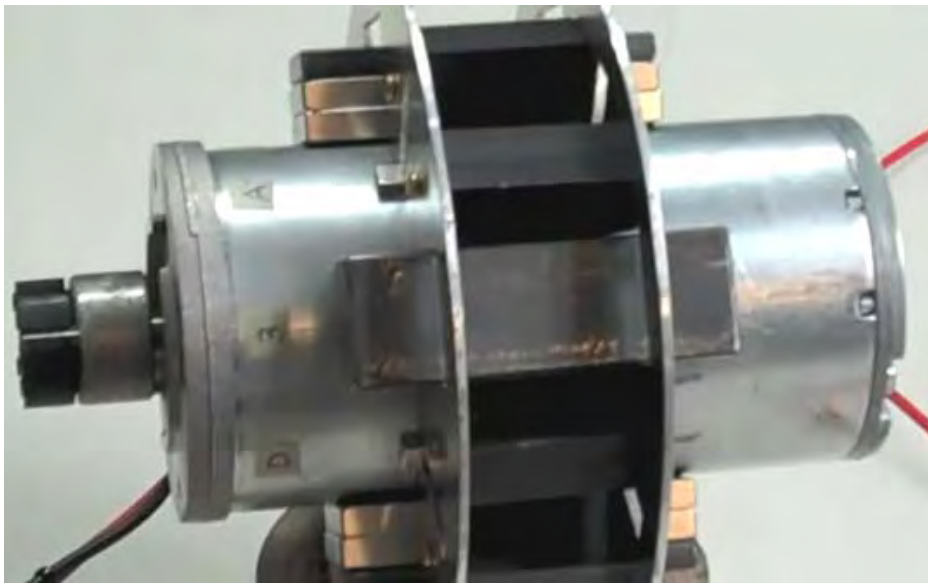

The motor is demonstrated when set up like that. Then four sets of very narrow magnets are added in intermediate positions and the number of broad magnets increased to three at each location, the steel strips discarded and four broad magnets used at each of the four locations around the motor:

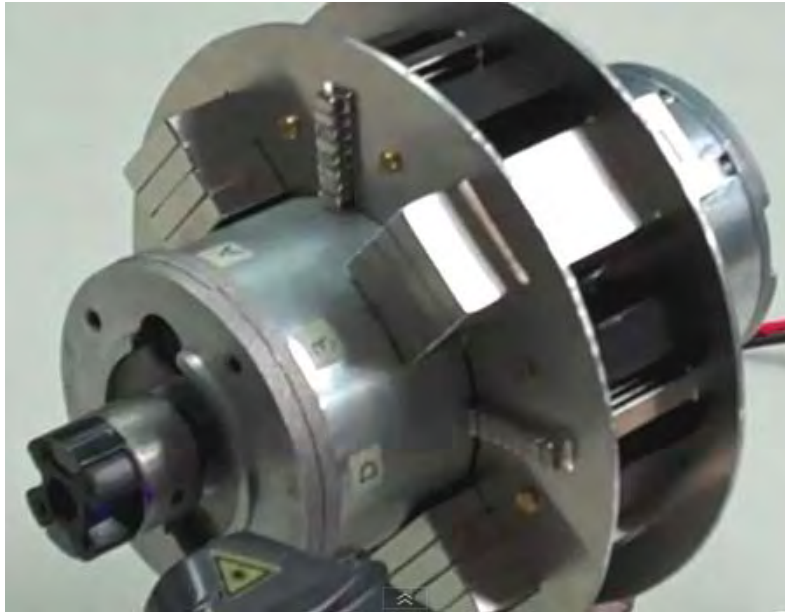

With this arrangement, the motor runs at ten times it's design speed (which would destroy it very quickly), so it is run with just one sixth of it's design voltage. It is used to drive an electric generator shown in two videos at: <http://www.youtube.com/watch?v=0dkiHUasERA&feature=related> and <http://www.youtube.com/watch?v=ZTLvqCiKadl&feature=related> which explain the sophisticated design features of this generator which has been built with great care:

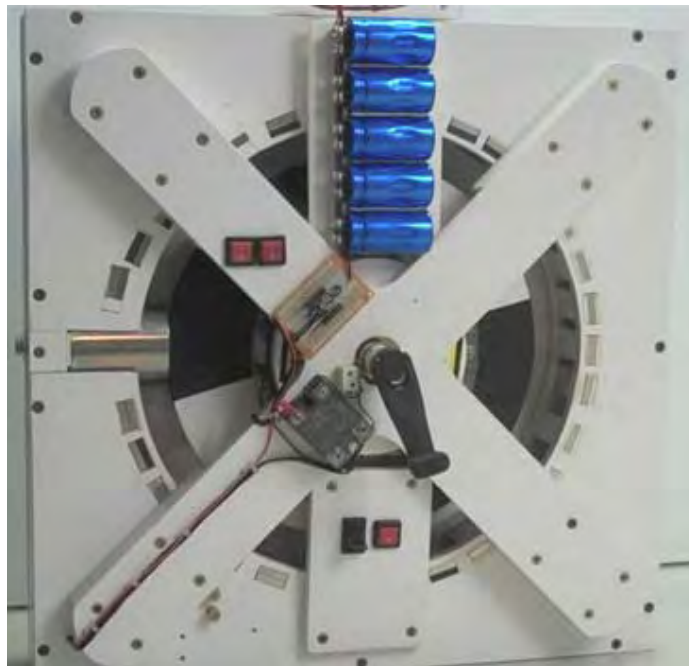

Given a couple of minutes of gentle turning of the crank, charges up the five batt-caps sufficiently to run the motor for anything up to two hours. The arrangement is clever with the stator magnets in a Howard Johnston sequence which is also angled inwards like the magnetic Wankel motor. One electromagnet is powered up briefly once per revolution and the back-EMF at switch-off is rectified and passed back to the capacitors, forming a very efficient generator. Other design features are explained in the videos which are definitely worth watching.

The generator, when running can discharge a rapid sequence of high-voltage sparks which the builder just uses for an interesting display. However, those spark discharges are quite capable of charging a bank of batteries (not

to mention, running a Don Smith style power device). The builder then goes on to add an ordinary capacitor to the series-connected batt-cap bank, and couples the motor to it:

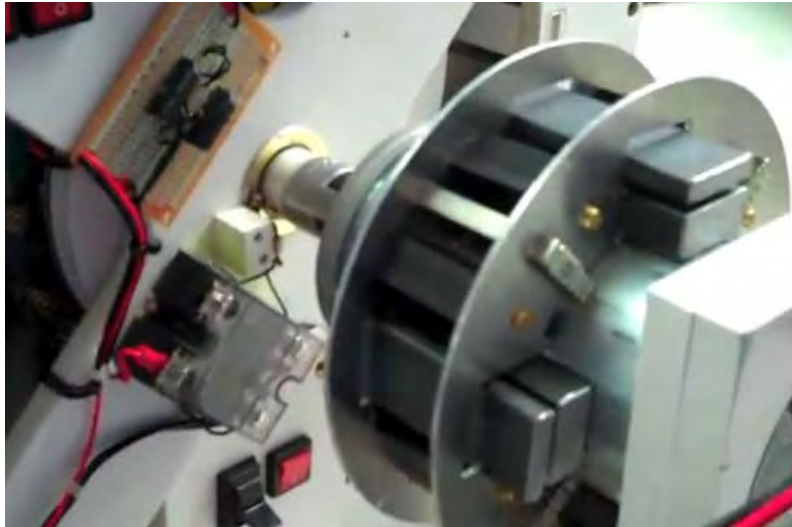

This allows the enhanced motor to become fully self-running as well as producing excess power which could easily charge a bank of large batteries. Incidentally, conventional science says that this is “impossible” and so they will only look at this machine with their eyes closed because they can’t afford to believe it – after all, that would require them to modify their present theories and the people who pay their salaries would not allow any such change.

This motor is shown running on capacitors, but if it is powered by an ordinary battery and run at it’s design speed of 3,300 rpm instead of the extremely low speed shown, then it should be able to charge up a serious bank of large batteries, one of which could then be used to power it for the next charging run.

The ‘UFOPolitics’ Motor

In chapter 2, there is a section on how an experimenter alters the wiring inside DC motors. This alteration has a major effect, boosting the output power by a major amount as well as providing an additional generated electrical output. One person who followed his instructions and rewound a tiny 3-volt 3-pole motor, then tried running that motor on a discharged 6-volt battery. The motor ran, slowly at first and then picked up speed. That seemed impossible as the motor draws 300 milliamps when running and the battery was just not capable of providing that current. However, impossible or not, the motor ran and not only did it run but it started recharging the battery driving it. This suggests that this is a self-sustaining system which provides output power and yet never needs to have the battery recharged.

The way that this happens is that what we think of as “electricity” is actually a more complex thing called “electromagnetism”. We think of electricity and magnetism as being two different things, while in fact, they are two different aspects of the single entity electromagnetism. The electric component always has an efficiency of less than 100% which the magnetic component always has an efficiency which is greater than 100% - something which we usually don’t notice as we tend to ignore the magnetic component.

In the case of this tiny 3-volt motor, it draws it’s running ‘hot electricity’ current from the battery. That causes rotating magnetic fields inside the motor and these generate ‘cold electricity’ which flows back along the supply wires and charges the battery.

Some Battery Charging Suggestions

Using a vehicle to charge batteries.

It is very easy to overlook the obvious. It is possible for people who do a fair bit of driving, possibly to and from work, or maybe dealing with a delivery round, to charge some additional batteries from the car alternator. Once the engine is started, additional batteries can be connected in parallel with the car battery, that is, the plus terminal of the extra battery or batteries connects to the car battery plus.

This does draw some additional energy from the car engine and in theory should cause some additional fuel to be used, but the extra fuel should be fairly minor as most of the power of the engine is used to push air aside as air resistance goes up with the cube of the speed of the vehicle. The charged batteries can be removed from the vehicle in the evening and used to power lights, TVs, DVD players, etc. in the evening by using a small commercial inverter.

Experimenting with a battery charger.

There is an interesting possibility when using one of the pulse battery chargers shown earlier in this chapter, say, an Alexkor solid-state pulser. Commonsense tells you that if you want to light a lamp using a battery, then the longer the lamp is to be lit, the larger the battery needs to be.

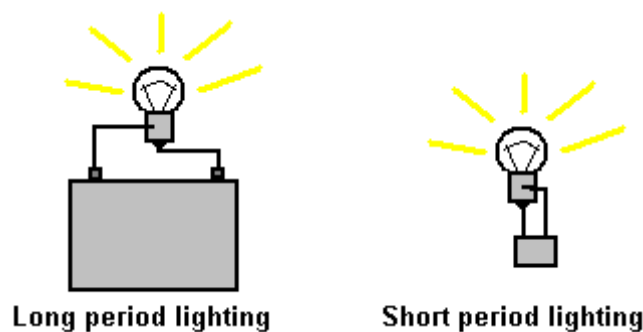

Looking at this from a slightly different viewpoint, we could say that the shorter the period of time when the battery has to power the bulb, the smaller the battery can be. So, for example, if the bulb only needed to be lit for ten seconds, then the battery could be quite small.

But suppose we were to reduce that time period to just one second, then the battery could be very small indeed and if we were to reduce the time period to one tenth of a second, then the battery power would be tiny compared to the power needed to run the light for say, one hour. This may seem trivial and obvious, but it is leading up to a strategy which could be useful.

Fairly recently, super capacitors have become available at reasonable price, with a 2.5V 5F capacitor costing as little as £3. Just to put this in perspective, in electronics, a 1000 microfarad capacitor is considered large and a 10,000 microfarad capacitor is considered to be very large. Well, a 5F capacitor is 500 times larger than a 10,000 microfarad capacitor. These capacitors charge up fully in just a few seconds, are 100% efficient and should remain operational for many years if not many decades.

Suppose then, that we were to connect a 6-volt bulb across a 6-volt lead-acid battery. If the battery were charged to say, 6.6 volts (measured one hour after being disconnected from a battery charger) and the lamp were connected across the battery and left lit until the battery voltage dropped to 5.0 volts (on load, as it will gain a good deal of voltage when the load is disconnected). Then that determines how long the battery can power the lamp when the battery is discharged that much.

It would be interesting to see if that length of time could be extended without using a larger battery. Suppose we were to connect a set of three of those super capacitors in series to form a 7.5V capacitors of 1.67F capacity, and then implemented the following circuit:

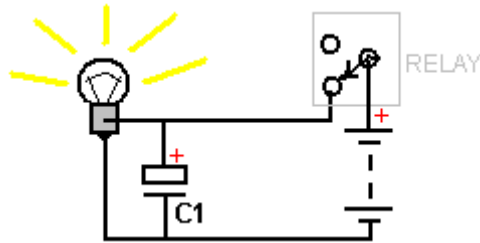

using a simple NE555 circuit to drive the relay On and Off once per second. Then, the battery would only be connected to the lamp for half of the time and it would be 'resting' for half of the time. That sounds like a mad idea as when the battery is connected it will have to both light the lamp and top up the charge in the capacitor, and some current is needed to run the NE555 circuit and drive the relay. That results in a poorer performance than before.

However, as the battery is disconnected for half of the time, we can use that fact to our advantage by extending the circuit to this arrangement:

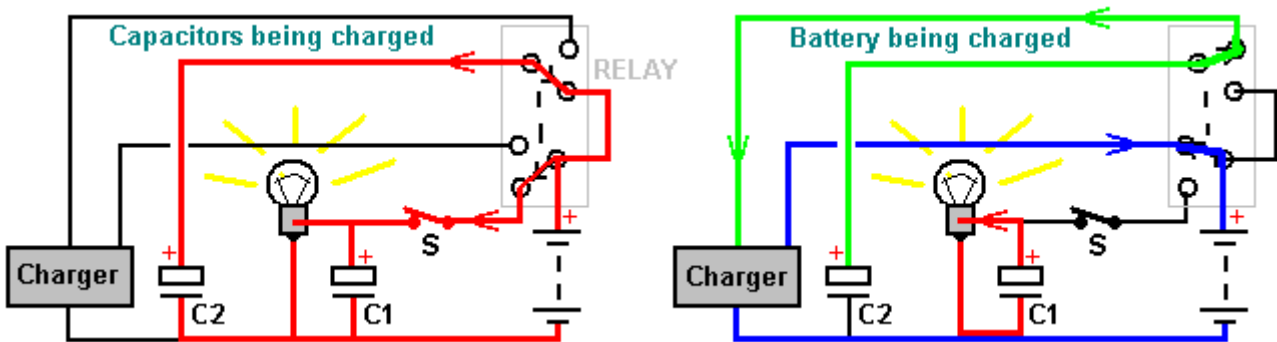

This makes the battery draw even worse as there are now two large capacitors which have to be topped up every second while the lamp is being powered and the NE555 circuit is also being powered. But, for half of the time, the relay is in its other position which connects capacitor "C2" to the battery pulse-charger, and at the same time, the 'resting' battery is connected to the output of the battery charger, feeding additional charge to it.

You might feel that a charging period of half a second is far too short to be of any use, but that is actually not the case. In chapter 5, there is mention of the 1989 patent US 4,829,225 granted to Yury Podrazhansky and Phillip Popp, their evidence is that batteries charge much better and have a longer life if they are pulsed in a specific way. Their formula is that the battery should be given a powerful charging pulse lasting for a period of time between a quarter of a second and two seconds, the pulse being the Amp-Hour rating of the battery. That is, for an 85 AHr battery, the charging pulse would be 85 amps. That pulse is then followed by a discharging pulse of the same, or even greater current but only maintained for only 0.2% to 5% of the duration of the charging pulse. Those two pulses are then followed by a resting period before the pulsing is repeated. They quote the following examples of their experiences when using this method:

Battery:	9V alkaline	1.25V NiCad 0.5 AHr	15V NiCad 2 AHr	12V lead-acid 40 AHr
Charging current:	0.5 Amps	1.2 Amps	3.0 Amps	48 Amps
Charging period:	550 mS	700 mS	500 mS	850 mS
Discharge current:	6 Amps	6 Amps	14 Amps	85 Amps
Discharge period:	2 to 3 mS	2 mS	2 mS	3 mS
Rest period:	15 to 20 mS	7 to 10 mS	10 mS	15 mS
Charging range:	50% to 100%	20% to 100%	20% to 100%	20% to 100%
Total charging time:	12 to 15 mins	20 mins	35 to 40 mins	40 mins

Of course, while this table of results does not apply directly to our proposed circuit, it does indicate that very satisfactory results can come from a very intermittent charging sequence and while I have, so far, spoken of a one-second cycle for our test circuit, that is purely due to the initial test use of a mechanical relay. If the test is

satisfactory, showing a longer length of time for the battery to reach an on-load voltage of 5 volts, and the relay circuit is replaced with a solid-state (lower current draw) circuit, then a switching time of maybe one tenth of a second might be used.

If the battery charger runs at 300,000 Hz (which is only 10% of some of the Alexkor circuits), then with a timing of one tenth of a second On time and one tenth of a second Off time, then the battery would receive about 30,000 charging pulses five times per second, which is 150,000 charging pulses every second, which is very close to some very successful battery chargers which operate all the time.

This is an untested idea, but it looks as if it might produce a usefully extended battery life and if the switch "S" is included in the circuit, then when it is opened, the battery may well be able to self-charge. As this arrangement is so simple, it might well be worth testing. The NE555 integrated circuit can provide up to 200 milliamps and so it could probably drive most 6V relays directly if the relay is connected between pin 3 and the plus of the battery. Initially, the NE555 circuit can be powered by a separate battery or power supply while the effect of the circuit is being checked out. Later on, if the circuit happens to work well, it could be powered by being connected to the battery via a choke and a smoothing capacitor (with a varistor across the capacitor if you want to play really safe) to block the charging pulses from the timing circuit, or it could be powered via an additional super capacitor or from one of the two existing capacitors. There is, of course, no reason why the NE555 circuit should have an On time equal to the Off time and so the timer's Mark/Space ratio could be made adjustable and tests run to see what the optimum setting would be. This could be an interesting experiment.

However, If you decide to test this idea, while you could use a relay to do the initial testing, it might be a good idea to test solid-state switching at the same time, as solid-state switching is likely to be much more reliable and have a much longer life. We might choose to use bi-polar transistors as they are the most reliable for lower voltage circuits, and so we might treat the circuit like this:

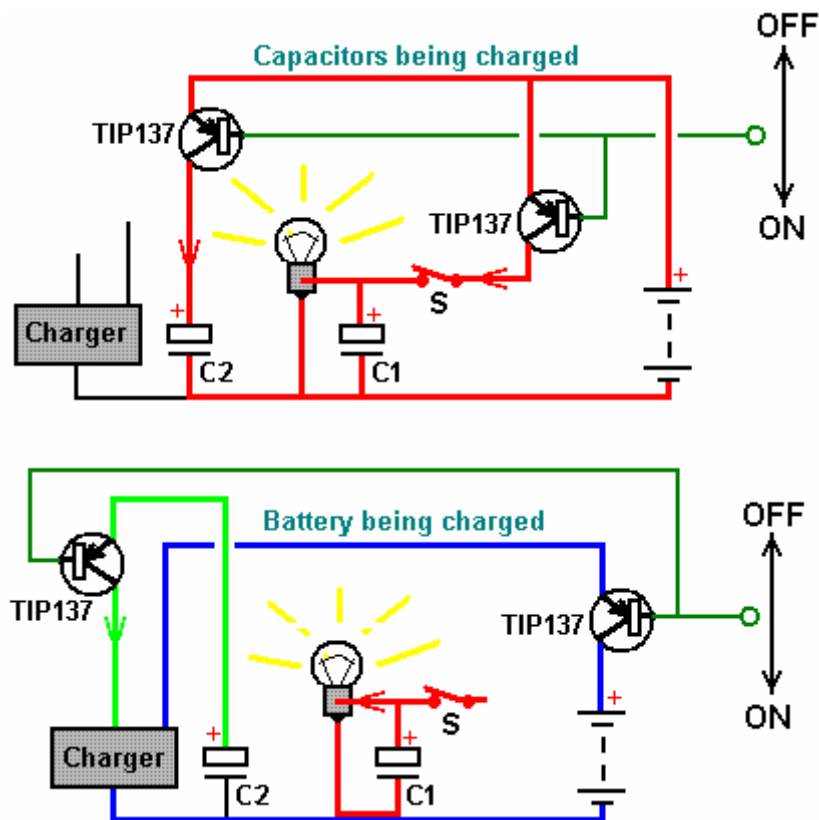

Maplins have 2.7V super capacitors at very reasonable prices. It would be necessary to connect four or five in series in order to meet the voltage requirements, although doing that reduces the overall capacitance substantially. It would be quite easy to add a dimmer control using a switched variable resistor and an emitter-follower transistor where the switch short-circuits the dimmer but when open, allows the voltage (and so, the current) applied to the LED bank, to be adjusted, as shown in the solar panel light suggestion at the end of chapter 14.

Initially, a slow-running 555 circuit could be used to drive one of the above circuits and invert the 555 output to drive the other circuit, using a transistor with a base resistor to protect it. A more practical charging circuit could be:

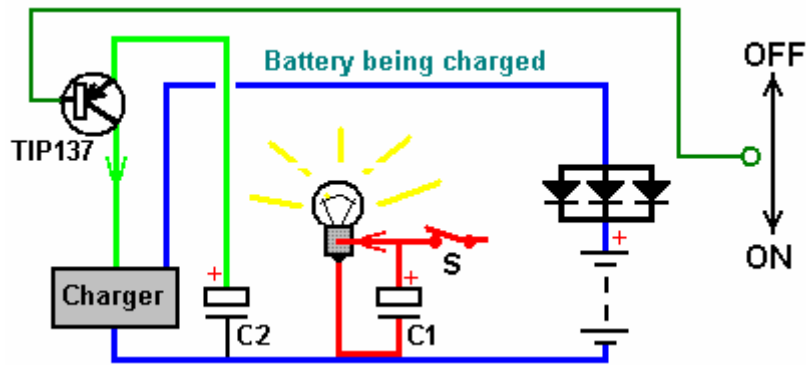

Here, the charger is connected to the battery at all times, through a diode (or perhaps more practically, through three or four diodes, such as UF5408, in parallel which feeds current better than one diode on its own), leading to a circuit something like this:

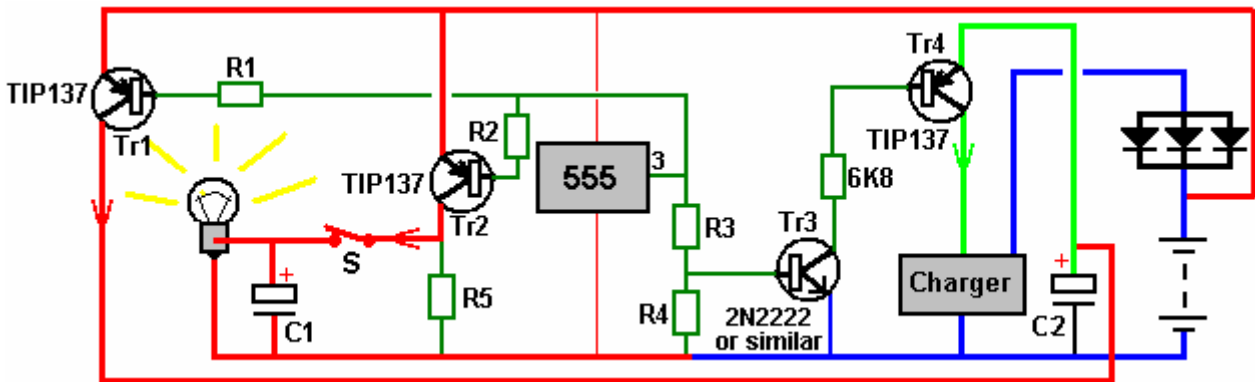

When pin 3 of the 555 goes low, resistors R1 and R2 control the current flow to transistors Tr1 and Tr2, switching them fully on in order to charge capacitors C1 and C2. Resistor R5 is a high value of say, 470K and is there just to provide a current flow path when the switch S is opened to turn the light off.

Resistor R3 is chosen to switch the 2N2222 transistor (or BC109, or other small-signal transistor) Tr3 fully on, when pin 3 goes high, and R4 is chosen to ensure that Tr3 switches fully off when pin 3 is low, switching the charger off by turning Tr4 off and starving it of current.

It is quite common for a charging circuit such as those from John Bedini or from Alexkor, to need the battery being charged to be connected in series to the battery which is driving the charging circuit (capacitor C2 in our case). This can be arranged like this:

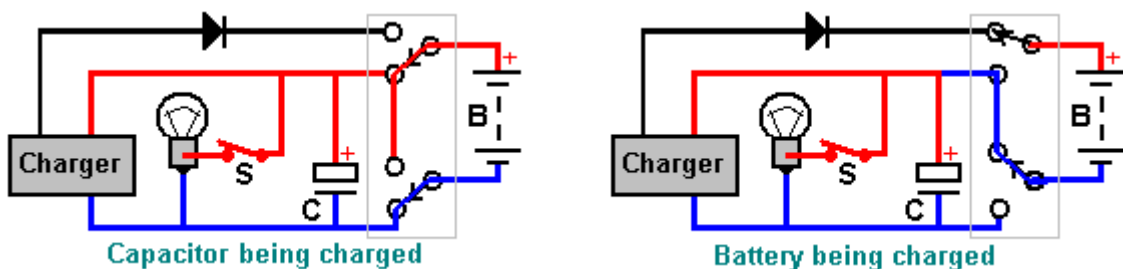

Here, the size of capacitor "C" is increased as it is now supplying both the light and the charging circuit, which runs all of the time. As the voltage spikes are high voltage and the resulting charging current very high, solid-state implementations of this arrangement require prototype testing before being shown here.

Ideally, for a USB output, we want an arrangement which draws no significant current when not in use and yet, which does not need a mechanical switch. For that we might do something like this:

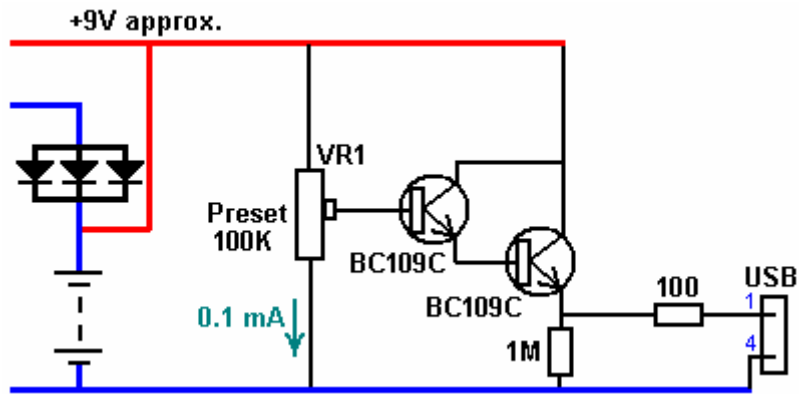

Here, the battery voltage of around 9V or 9.8V or whatever, is connected across a 100K variable resistor which will waste just under 0.1 milliamps. Two (low-cost) BC109C transistors are connected as a Darlington pair in emitter-follower mode with a 1M resistor as their load. These transistors have a gain which typically exceed 200, and so, two together like this draws only one 40,000 th of the proposed 10 mA current, and that is just 0.25 microamps which is about 0.25% of the current flowing through VR1 and so, even under load, the VR1 voltage will be steady. This wastes another 0.006 milliamps when VR1 is adjusted to give about 5.3V as an output when under load. A 100 ohm resistor is connected in series with this output and pin 1 of the 'type A' USB socket. As pins 1 and 4 are open-circuit, no current flows through this resistor until such time as a load is connected between pins 1 and 4.

If pins 1 and 4 were short-circuited – which is a most unlikely occurrence, then the current through the 120 ohm resistor would be 52.5 milliamps, which indicates that that resistor should be a half-watt type as that dissipation is 330 mW. The most effective way to make the initial adjustment would be to set the output voltage low, connect a mobile phone to the socket and adjust VR1 to give 5.3V or so on the socket. Preventing over-charging of the battery might be done with a circuit of this type:

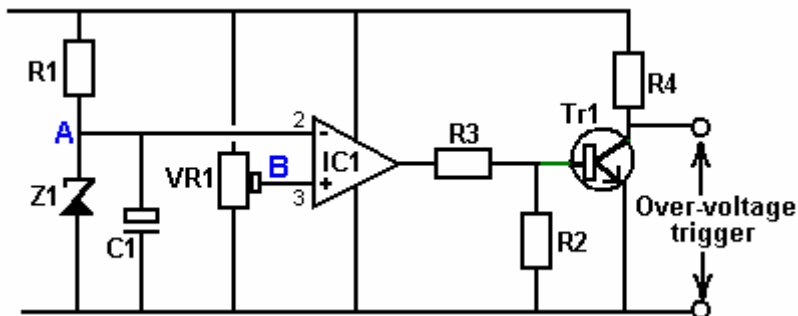

Point "A" is a reference voltage provided by resistor R1 and zener diode Z1 and held at a steady voltage by capacitor C1. The Op-amp IC1 acts as a voltage comparator between points "A" and "B" (which is set by the preset variable resistor VR1 and reflects the overall voltage of the battery). The output voltage of IC1 will change sharply if the voltage difference between "A" and "B" swaps over, but by no means to the rail voltages, so transistor Tr1 is there to give a full logic swing. The transistor base current is set by resistor R3 and resistor R2 is there to ensure that Tr1 switches off properly. Resistor R4 has quite a high value as it is just there to form a voltage divider pair with Tr1.

The op-amp might be an LM358 as it will operate with voltages as low as 4.5V, it is very cheap, and it draws almost no current. As the package has two op-amps in it, the second one can be connected as a buffer:

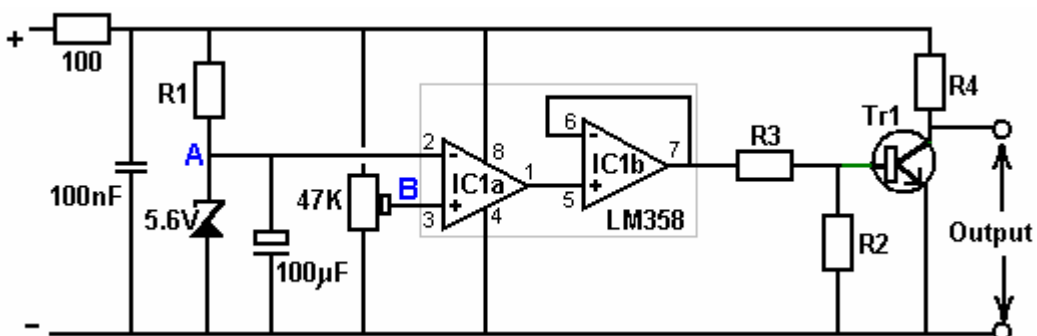

As we want the circuit to switch as the battery voltage increases, point B must start at a lower voltage than point A. If connected as shown, then Tr1 will be on when the battery is charging and will switch off when the battery is fully charged at a voltage set by the position of the slider of VR1.

As the battery is receiving high-voltage spikes when being charged, the input to this section of the circuit is buffered by the 100 ohm resistor and the 100 nF capacitor is there to attempt to short-circuit spikes which get through the 100 ohm resistor. An inductor would probably be better than the 100 ohm resistor for suppressing voltage spikes and connecting a much larger capacitor in parallel with the 100 nF capacitor might be an additional help in keeping the voltage rails of this section of the circuit at a steady average voltage. The choice of resistor R1 and the voltage of the zener diode are not critical. The current through R1 can be very low as IC1 needs almost no current and as there is a reservoir capacitor across the zener diode and that will keep the voltage steady.

Resistors R2 and R3 are chosen to suit Tr1, R3 to ensure that it switches on properly when connected to the charger circuit and R2 to make sure that it switches off properly when then output pin 7 of IC1b drops to its lowest value of about 2 volts. It is likely that R4 will not be needed as TR1 will probably be connected direct into the charging circuit in order to power it down or stop it oscillating.

Patrick Kelly

<http://www.free-energy-info.tuks.nl/>

Chapter 7: Aerial Systems and Electrostatic Generators

It is generally thought that aerials are not capable of gathering much power. The popular conception is that the only power available is low level radio waves from distant radio transmitters, and while it is certainly true that radio waves can be picked up with an aerial, the real sources of power are not radio transmitters.

For example, we will be looking at information from Hermann Plauson and he considered any aerial system of his which did not produce more than an excess power of 100 kilowatts, as a "small" system (admittedly, with many aerials). Thomas Henry Moray demonstrated his system to audiences repeatedly, pulling in power levels of up to 50 kilowatts from a single sort aerial. These power levels are not produced by radio station signals.

Nikola Tesla's Aerial System.

Nikola Tesla produced an aerial device which is worth mentioning. It was patented on May 21st 1901 as an "Apparatus for the Utilisation of Radiant Energy", US Patent number 685,957.



The device appears simple but Tesla states that the capacitor needs to be "of considerable electrostatic capacity" and he recommends using the best quality mica to construct it as described in his 1897 patent No. 577,671. The circuit draws power via an insulated, shiny metal plate. The insulation could be spray-on plastic. The larger the plate, the greater the energy pick-up. The higher the plate is elevated, the greater the pick-up.

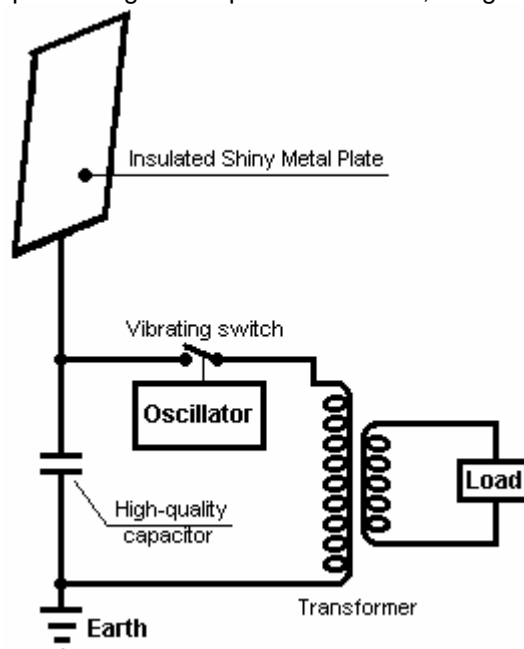

This system of Tesla's picks up energy day and night. The capacitor gets charged up and a vibrating switch repeatedly discharges the capacitor into the step-down transformer. The transformer lowers the voltage and raises the current available and the output is then used to power the electrical load.

It seems probable that this device operates primarily from static electricity, which some people believe is a manifestation of the zero-point energy field. Tesla's equipment might well operate when fed by a motor-driven

Wimshurst machine instead of a large aerial plate. Details of home-built Wimshurst equipment are available in the book 'Homemade Lightning' by R.A. Ford, ISBN 0-07-021528-6.

However, it should be understood that Tesla described two different forms of energy pick-up. The first is static electricity, picked up from very slight interaction of the pick-up plate with the zero-point energy field flowing through it, and the other being pick-up of dynamic radiant energy events, typically from lightning strikes. At a casual glance, the average person would not consider lightning as being a viable source of energy, but this is not the case as there are about two hundred lightning strikes per second - mainly in the tropics - and what is generally not understood is that they are radiant energy events and their effects are felt instantly everywhere on earth as transmissions through the zero-point energy field are instantaneous at any distance. To clarify the situation a little more, here are two of Tesla's patents, one on pick-up of the static field which Tesla remarks appears to be unlimited in voltage, and one patent on pick-up of dynamic energy.

This is a slightly re-worded copy of this patent, as some words have changed their meaning since this patent was issued. If you wish to see the original, then <http://www.freepatentsonline.com> will allow you to download a copy without any charge.

Patent US 685,957

5th November 1901

Inventor: Nikola Tesla

APPARATUS FOR THE UTILISATION OF RADIANT ENERGY

To all whom it may concern:

Be it known that I, Nikola Tesla, a citizen of the United States, residing at the borough of Manhattan, in the city, county and State of New York, have invented certain new and useful improvements in Apparatus for the Utilisation of Radiant Energy, of which the following is a specification, reference being had to the drawings accompanying and forming a part of the same.

It is well known that certain radiations - such as those of ultra-violet light, cathodic, Roentgen rays, or the like - possess the property of charging and discharging conductors of electricity, the discharge being particularly noticeable when the conductor upon which the rays impinge is negatively electrified. These radiations are generally considered to be ether vibrations of extremely small wave lengths, and in explanation of the phenomena noted, it has been assumed by some authorities that they ionise, or render conducting, the atmosphere through which they are propagated. However, my own experiments and observations lead me to conclusions more in accord with the theory heretofore advanced by me that sources of such radiant energy throw off with great velocity, minute particles of matter which are strongly electrified, and therefore capable of charging an electrical conductor, or, even if not so, may at any rate discharge an electrified conductor, either by bodily carrying off its charge or otherwise.

My present application is based upon a discovery which I have made that when rays or radiations of the above kind are permitted to fall upon an insulated conducting-body connected to one of the terminals of a capacitor, while the other terminal of the capacitor is made to receive or carry away electricity, a current flows into the capacitor so long as the insulated body is exposed to the rays, and under the conditions specified below, an indefinite accumulation of electrical energy in the capacitor takes place. After a suitable time interval during which the rays are allowed to act, this energy may manifest itself in a powerful discharge, which may be used for the operation or control of mechanical or electrical devices, or rendered useful in many other ways.

In applying my discovery, I provide a capacitor, preferably of considerable electrostatic capacity, and connect one of its terminals to an insulated metal plate or other conducting-body exposed to the rays or streams of radiant matter. It is very important, particularly in view of the fact that electrical energy is generally supplied to the capacitor at a very slow rate, to construct the capacitor with the greatest care. I prefer to use the best quality of mica as the dielectric, taking every possible precaution in insulating the armatures, so that the instrument may withstand great electrical pressures without leaking and may leave no perceptible electrification when discharging instantaneously. In practice, I have found that the best results are obtained with capacitors treated in the manner described in Patent 577,671 granted to me on 23rd February 1897. Obviously, the above precautions should be the more rigorously observed the slower the rate of charging and the smaller the time interval during which the energy is allowed to accumulate in the capacitor. The insulated plate or conducting-body should present to the rays or streams of matter, as large a surface as is practical, I having ascertained that the amount of energy conveyed to it per unit of time is, under otherwise identical conditions, proportional to the area exposed, or nearly so. Furthermore, the surface should be clean and preferably highly polished or amalgamated. The second terminal or armature of the capacitor may be connected to one of the poles of a battery or other source of electricity, or to any conducting body or object whatever of such properties or so conditioned that by its means, electricity of the required sign will be supplied to the terminal. A simple way of supplying positive or negative

electricity to the terminal is to connect it to an insulated conductor supported at some height in the atmosphere, or to a grounded conductor, the former, as is well known, furnishing positive, and the latter negative electricity. As the rays or supposed streams of matter generally convey a positive charge to the first terminal of the capacitor mentioned above. I usually connect the second terminal of the capacitor to the ground, this being the most convenient way of obtaining negative electricity, dispensing with the necessity of providing an artificial source. In order to use the energy collected in the capacitor for any useful purpose, I also connect to the capacitor terminals, a circuit containing an instrument or apparatus which it is desired to operate, and another instrument or device for alternately closing and opening the circuit. This latter device can be any form of circuit-controller with fixed or moveable parts or electrodes, which may be actuated either by the stored energy or by independent means.

My discovery will be more fully understood from the following description and drawings, where **Fig.1** is a diagram showing the general arrangement of the apparatus as usually employed.

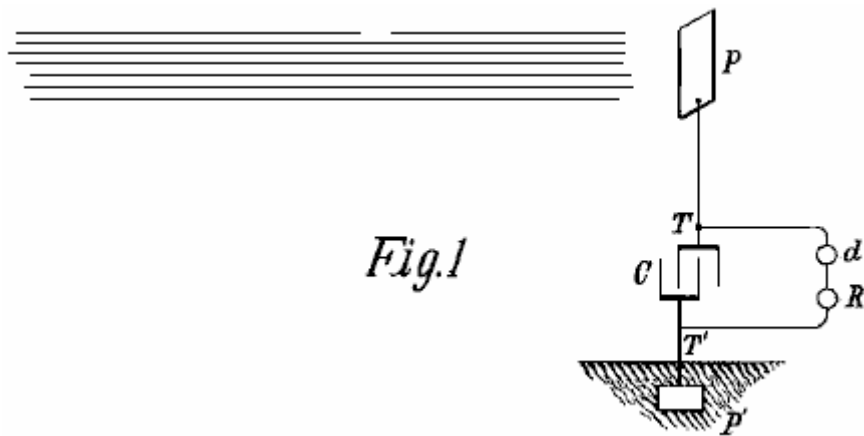

Fig.1

Fig.2 is a similar diagram, illustrating in more detail, typical forms of the devices or elements used in practice.

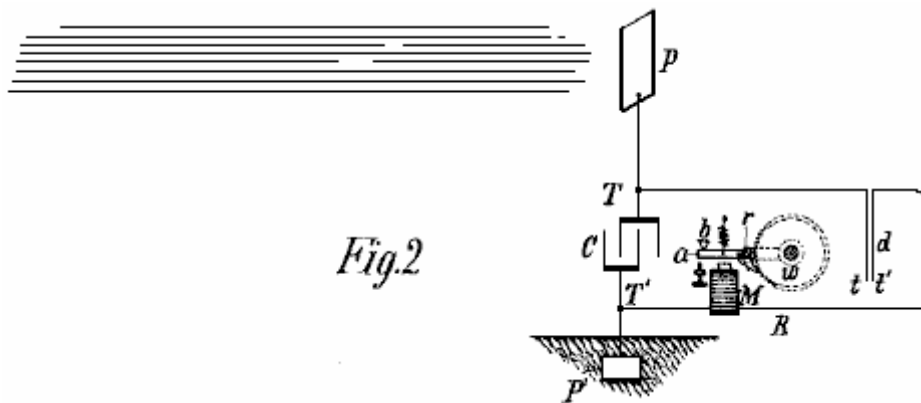

Fig.2

Fig.3 and **Fig.4** are diagrams of modified arrangements suitable for special purposes.

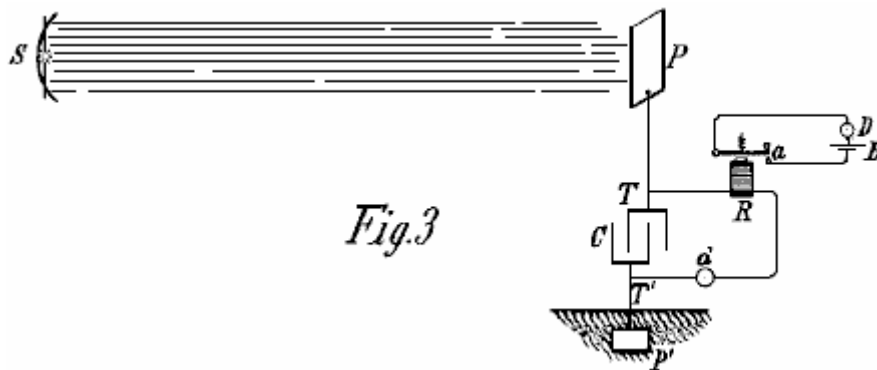

Fig.3

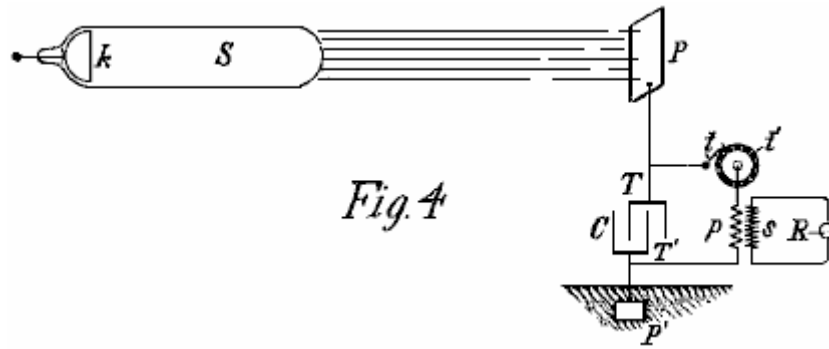

Fig. 4

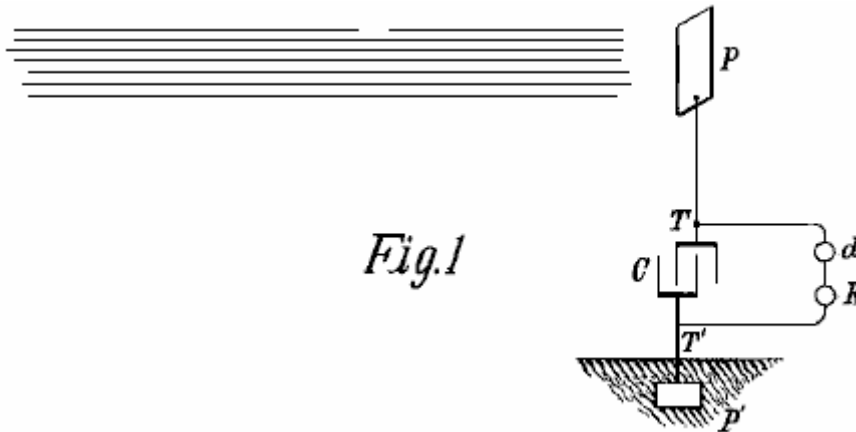

Fig. 1

Fig.1 shows the simplest form, in which **C** is the capacitor, **P** the insulated plate or conducting-body which is exposed to the rays, and **P'** another plate or conductor which is grounded, all being connected in series as shown. The terminals **T** and **T'** of the capacitor **C** are also connected to a circuit which contains a device **R** which is to be operated, and a circuit-controlling device **d** as described above.

The apparatus being arranged as shown, it will be found that when the radiation of the sun, or any other source capable of producing the effects described above, fall on plate **P**, there will be an accumulation of energy in capacitor **C**. I believe that this phenomenon is best explained as follows: The sun, as well as other sources of radiant energy, throws off minute particles of positively electrified matter, which striking plate **P**, create an electrical charge on it. The opposite terminal of the capacitor being connected to the ground, which can be considered to be a vast reservoir of negative electricity, a feeble current flows continuously into the capacitor, and since these supposed particles are of an inconceivably small radius or curvature, and consequently, charged to a very high voltage, this charging of the capacitor may continue as I have actually observed, almost indefinitely, even to the point of rupturing the dielectric. If the device **d** be of such character that it will operate to close the circuit in which it is included when the capacitor voltage has reached a certain level, then the accumulated charge will pass through the circuit, operating the receiver **R**.

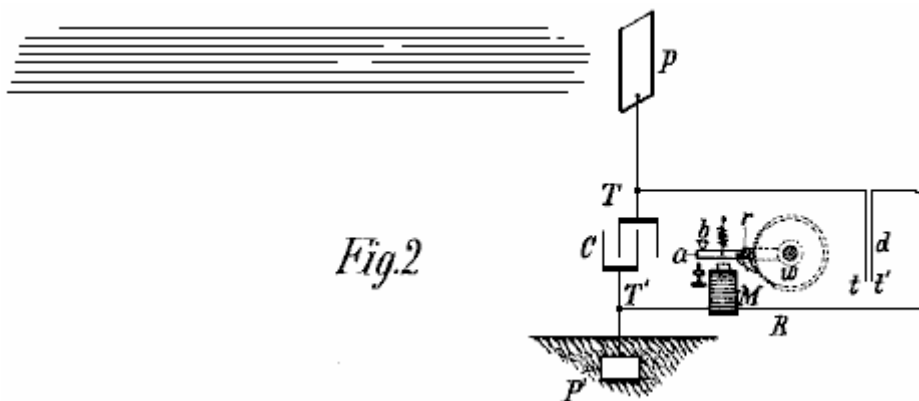

Fig. 2

In illustration of this effect, **Fig.2** shows the same general arrangement as in **Fig.1**, and the device **d** is shown composed of two very thin conducting plates **t** and **t'** which are free to move and placed very close to each other. The freedom of movement can be either through the flexibility of the plates or through the character of their support. To improve their action they should be enclosed in a housing which can have the air removed from it.

The plates **t** and **t'** are connected in series in a working circuit which includes a suitable receiver, which in this example is shown as an electromagnet **M**, a moveable armature **a**, a spring **b**, and a ratchet wheel **w**, provided with a spring-pawl **r**, which is pivoted to armature **a** as illustrated. When the radiation falls on plate **P**, a current flows into the capacitor until its voltage causes the plates **t** and **t'** to be attracted together, closing the circuit and energising the magnet **M**, causing it to draw down the armature **a** and cause a partial rotation of the ratchet wheel **w**. When the current flow stops, the armature is retracted by the spring **b**, without, however, moving the wheel **w**. With the stoppage of the current, the plates **t** and **t'** cease to be attracted and separate, thus restoring the circuit to its original condition.

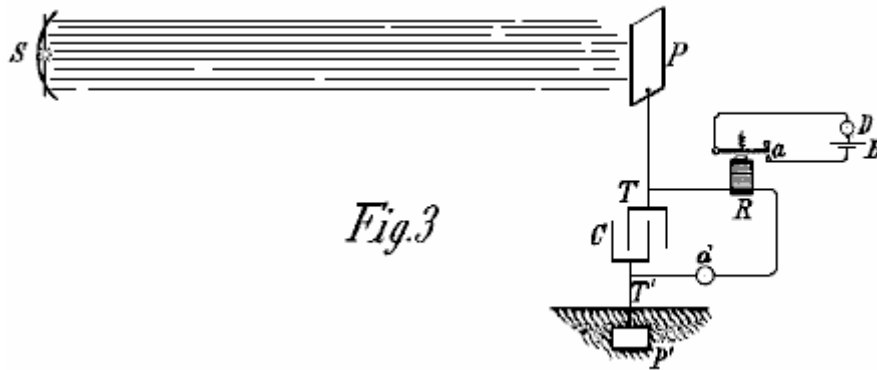

Fig. 3

Fig. 3 shows a modified form of apparatus used in connection with an artificial source of radiant energy, which in this case may be an arc emitting copious ultra-violet rays. A suitable reflector may be provided for concentrating and directing the radiation. A magnet **R** and circuit-controller **d** are arranged as in the previous figures, but in this case, instead of performing the whole of the work, the magnet performs the task of alternately opening and closing a local circuit, containing a source of current **B** and a receiving or translating device **D**. The controller **d** may, if desired, consist of two fixed electrodes separated by a minute air gap or weak dielectric film which breaks down more or less suddenly when a definite voltage difference is reached at the terminals of the capacitor, and returns to its original state when the discharge occurs.

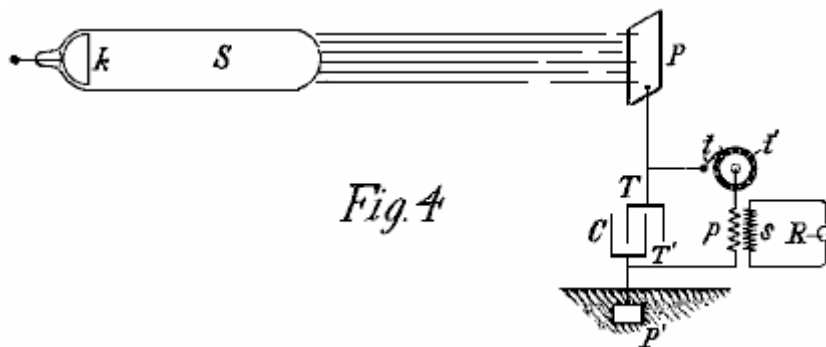

Fig. 4

Still another modification is shown in **Fig. 4**, in which **S**, the source of radiant energy is a special form of Roentgen tube devised by me, having only one terminal **k**, generally of aluminium, in the form of half a sphere, with a plain polished surface on the front side, from which the streams are thrown off. It may be excited by attaching it to one of the terminals of any generator with sufficiently high electromotive force; but whatever apparatus is used, it is important that the tube has the air inside it removed to a high degree, otherwise it might prove to be entirely ineffective. The working, or discharge circuit connected to the terminals **T** and **T'** of the capacitor, includes, in this case, the primary winding **p** of a transformer, and a circuit-controller comprised of a fixed terminal or brush **t** and a moveable terminal **t'** in the shape of a wheel, with conducting and insulating segments, which may be rotated at an arbitrary speed by any suitable means. In inductive relation to the primary winding **p**, is a secondary winding **s**, usually of a much greater number of turns, to the ends of which is connected a receiver **R**. The terminals of the capacitor being connected as shown, one to an insulated plate **P** and the other to a grounded plate **P'**. When the tube **S** is excited, rays or streams of matter are emitted from it and these convey a positive charge to the plate **P** and capacitor terminal **T**, while the capacitor terminal **T'** is continuously receiving negative electricity from plate **P'**. As already explained, this results in an accumulation of electrical energy in the capacitor, and this continues as long as the circuit including the primary winding **p** is interrupted. Whenever the circuit is closed by the rotation of the terminal **t'**, the stored energy is discharged through the primary winding **p**, giving rise to induced currents in the secondary winding **s**, which operates the receiver **R**.

It is clear from what has been stated above, that if the terminal **T** is connected to a plate supplying positive instead of negative electricity, then the rays should convey negative electricity to plate **P**. The source **S** may be any form of Roentgen or Leonard tube, but it is obvious from the theory of action that in order to be very effective, the impulses exciting it should be wholly, or mainly of one sign. If ordinary symmetrical alternating currents are employed, then provision should be made for allowing the rays to fall on plate **P** only during those periods when they can produce the desired result. Obviously, if the source radiation is stopped or intercepted, or the intensity varied in any manner such as periodically interrupting or rhythmically varying the current exciting the source, there will be corresponding changes in the action upon the receiver **R** and thus signals may be transmitted and many other useful effects produced. Further, it will be understood that any form of circuit-closer which will respond, or be set in operation when a predetermined amount of energy is stored in the capacitor, may be used instead of the device already described in connection with **Fig.2**.

The second patent requires the equipment to be tuned to one quarter of the wavelength of the energy pulses being collected. This patent shows a transmission method as well as a receiving method, but our main concern here is the receiving section shown on the right of the diagram as that can receive naturally occurring energy pulses in the environment and so provides free usable energy.

As it may be a little difficult to visualise the coil arrangement in this patent as many people are familiar with the "Tesla Coil" arrangement where a few turns of thick wire or copper tubing are used as a winding placed around an ordinary cylindrical coil, much like, this illustration from Tesla's patent US 568,178:

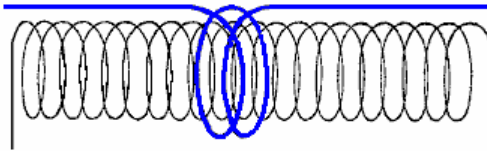

In this case it should be understood that Tesla is speaking about his flat "pancake" coil design and not the well-known Tesla Coil configuration.

Patent US 649,621

15th May 1900

Inventor: Nikola Tesla

APPARATUS FOR THE TRANSMISSION OF ELECTRICAL ENERGY

To all whom it may concern:

Be it known that I, Nikola Tesla, a citizen of the United States, residing at the borough of Manhattan, in the city, county and State of New York, have invented certain new and useful improvements in Apparatus for the Transmission of Electrical Energy, of which the following is a specification, reference being had to the drawing accompanying and forming a part of the same.

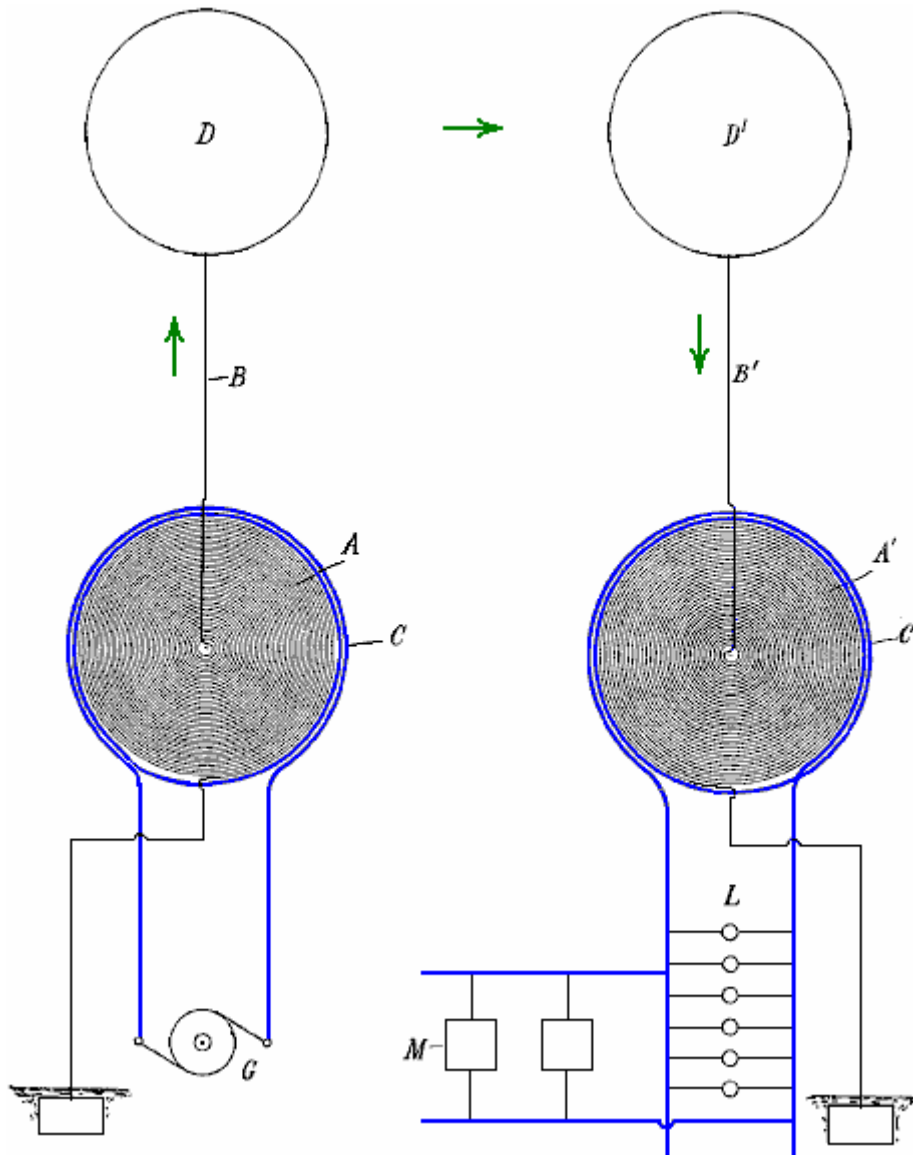

This application is a division of an application filed by me on 2nd September 1897, US 650,343 entitled "Systems of Transmission of Electrical Energy" and is based on new and useful features and combinations of apparatus shown and described in that patent application.

This invention comprises a transmitting coil or conductor in which electrical currents or oscillations are produced and which is arranged to cause these currents or oscillations to be propagated by conduction through the natural medium from one location to a remote location, and a receiving coil or conductor adapted to be excited by the oscillations or currents propagated by the transmitter.

This apparatus is shown in the accompanying diagram where **A** is a coil, generally of many turns and of a very large diameter, wound in spiral form, either around a magnetic core or not as may be desired. **C** is a second coil formed by a conductor of much larger size and smaller length, wound around and in proximity to coil **A**.

The apparatus at one point is used as a transmitter, the coil **A** in this case forming a high-voltage secondary of a transformer, and the coil **C** the primary which operates at a much lower voltage. The source of current for the primary winding is marked **G**. One terminal of the secondary winding **A** is at the centre of the spiral coil, and from this terminal the current is led by a conductor **B** to a terminal **D**, preferably of large surface, formed or maintained by such means as a balloon at an elevation suitable for the purpose of transmission. The other terminal of the secondary winding **A** is connected to earth, and if desired, to the primary winding also in order that the primary winding may also be at substantially the same voltage as the adjacent portions of the secondary winding, thus ensuring safety.

At the receiving station, a transformer of similar construction is used, but in this case the coil **A'** constitutes the primary winding and the shorter coil **C'** is the secondary winding. In this receiving circuit, lamps **L**, motors **M**, or other devices for using this current, are connected. The elevated terminal **D'** connects with the centre of the coil **A'** and the other terminal is connected to earth and preferably, also, to the coil **C'** again for safety reasons as mentioned above.

The length of the thin wire coil in each transformer should be approximately one quarter of the wave length of the electric disturbance in the circuit, this estimate being based on the velocity of propagation of the disturbance through the coil itself and the circuit with which it is designed to be used. By way of illustration, if the rate at which the current flows through the circuit containing the coil is 185,000 miles per second, then a frequency of 925 Hz would maintain 925 stationary nodes in a circuit 185,000 miles long and each wave would be 200 miles in length.

For such a low frequency, which would only be resorted to when it is indispensable for the operation of ordinary motors, I would use a secondary winding wound from a wire 50 miles in length. By adjusting the length of wire in the secondary winding, the points of highest voltage are made to coincide with the elevated terminals **D** and **D'**, and it should be understood that whatever wire length is chosen, this length requirement should be complied with in order to get the best possible results.

It will be readily understood that when these relationships exist, the best conditions for resonance between the transmitting and receiving circuits are attained and owing to the fact that the points of highest voltage in the coils **A** and **A'** are coincident with the elevated terminals, the maximum current flow will take place in the two coils and this implies that the capacitance and inductance in each of the circuits have the values which produce the most perfect synchronism with the oscillations.

When the source of current **G** is in operation and produces rapidly pulsating or oscillating currents in the circuit of coil **C**, corresponding induced currents of very much higher voltage are generated in the secondary coil **A**, and since the voltage in that coil gradually increases with the number of turns towards the centre, and the voltage difference between adjacent turns is comparatively small, a very high voltage is generated, which would not be possible with ordinary coils.

As the main objective is to produce a current with excessively high voltage, this objective is facilitated by using a current in the primary winding which has a very considerable frequency, but that frequency is in a large measure, arbitrary, because if the voltage is sufficiently high and the terminals of the coils be kept at the proper height where the atmosphere is rarefied, the stratum of air will serve as a conducting medium with even less resistance than through an ordinary conductor.

As to the elevation of terminals **D** and **D'**, it is obvious that this is a matter which will be determined by a number of things, such as the amount and the quality of the work to be performed, the condition of the atmosphere and the character of the surrounding countryside. Thus, if there are high mountains in the vicinity, then the terminals should be at a greater height, and generally, they should be at an altitude much greater than that of the highest objects near them. Since, by the means described, practically any voltage which is desired may be produced, the currents through the air strata may be very small, thus reducing the loss in the air.

The apparatus at the receiving station responds to the currents propagated by the transmitter in a manner which will be well understood from the description above. The primary circuit of the receiver - that is, the thin wire coil **A'** - is excited by the currents propagated by conduction through the intervening natural medium between it and the transmitter, and these currents induce in the secondary coil **C'**, other currents which are used to operate the devices connected to that circuit.

Obviously, the receiving coils, transformers, or other apparatus may be moveable - as for instance, when they are carried by a vessel floating in the air or by a ship at sea. In the former case, the connection of one terminal of the receiving apparatus to the ground might not be permanent, but might be intermittently or inductively established.

It should be noted that Tesla's suggestion of using the conductive envelope of a specially constructed balloon as a good method of increasing the active area of the elevated receiving plate, is one that was taken up by Hermann Plauson when he was building power stations operating on naturally occurring energy.

Jes Ascanius' Version of Nikola Tesla's Aerial System.

This sort of information may seem confusing and maybe a little too technical for you, so let me tell you about the practical and useful applications used by Jes Ascanius, a Danish developer, to whom thanks is due for sharing his design. Initially, he set up a system to charge his mobile phone battery overnight from an aerial. Then he went on to produce a full-size Tesla Aerial System as described at the start of this chapter. Let's start with the very simple system and progress from that to the more powerful arrangements.

The initial circuit uses one strand of solid wire which rises vertically to a 700 mm diameter drum where there are some twenty turns. The arrangement is like this:

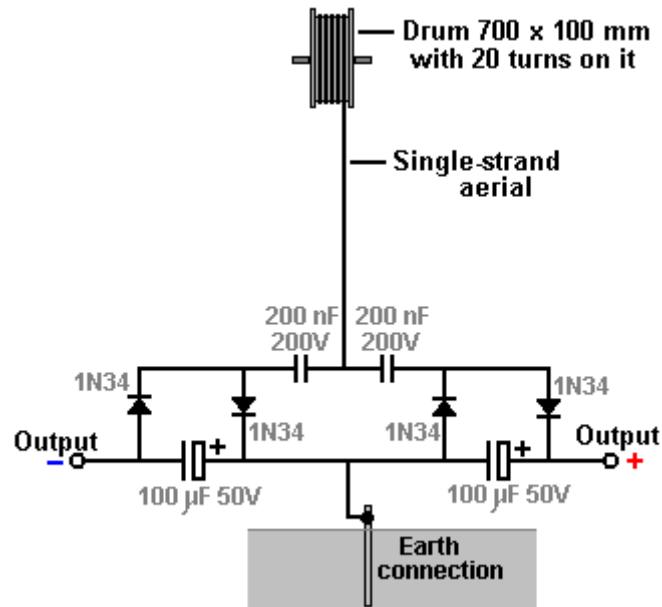

The aerial wire is several metres long, and in the prototype, was supported by (and insulated from) the eaves of a house. The aerial should be vertical or near vertical and a proper earth connection provided by driving a metal rod into the ground or connecting a wire to a metal plate and burying the plate in the ground as a good electrical connection is needed here. The earth connection used here is a 12 mm copper pipe 3 metres long, driven into the ground and the ground around it saturated with water:



The wire used to connect with the earthing rod is very important and should not be less than 8 swg copper wire, that is, 4 mm diameter and 13 sq. mm. cross-sectional area. As with all free-energy devices, the exact constructional details are vital.

The diodes used are germanium 1N34 or 1N34a which are particularly suited to this application. Ceramic disc types are recommended for the 200 nF capacitors. The prototype build looked like this:





Now, consider this circuit as described, to be one modular building block which can lead to unlimited power from an aerial. I will represent the circuit shown above as a rectangle, showing the above circuit as:

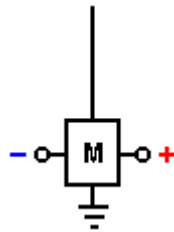

While it is possible to use more than one module with the aerial to get more power, the Danish developer then switched to the full-blown Tesla arrangement by attaching a 600 x 800 x 2 mm aluminium plate inside the sloping roof of his house:



The plate being suspended using nylon cord to prevent it touching the roof or anything else:



The plate is positioned between 3 and 3.5 metres (10 to 12 feet) above the ground and the attachment to the plate is also heavy-duty 8 swg cable:

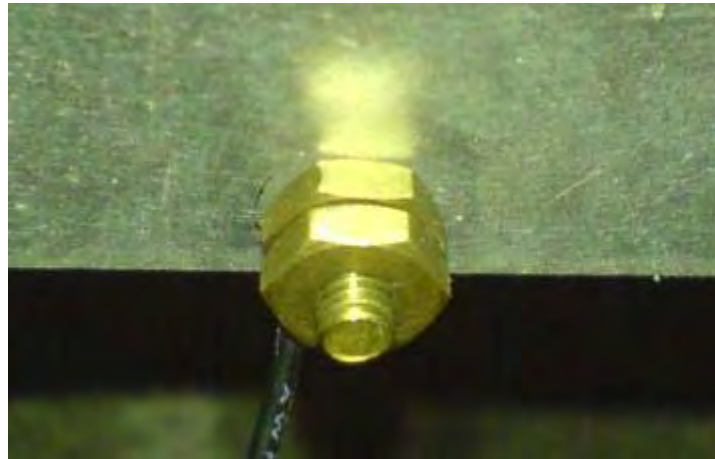

The cable is connected to the aluminium plate using a brass bolt and nuts which the builder thinks may be significant, quite apart from avoiding any galvanitic connection to the circuit. The cable is then run vertically downwards to the circuit. For this arrangement a second earthing point is also used. This is a galvanised iron pipe 3 metres long, driven vertically into the ground which is saturated with water. The second earth is 2 metres away from the first earth and there is no known significance in the use of an iron pipe as it was used because it was to hand at the time..

This arrangement provides serious power, enough to cause injury to, or kill a careless human. With two modules, it will light an LED very brightly, driving it to 2.6 volts. If the LED is removed, then the voltage climbs to about twenty volts and is easily sufficient to charge a 12V battery or battery bank although that takes time. With twenty modules a 12V battery can be charged over night. It is estimated that with two hundred modules, the power would be sufficient to power a household although that has not yet been done. It should be borne in mind that each module is easy and cheap to make, so arranging for a stack of them where additional modules can be added at a later date for more power, is an ideal arrangement. The circuit is like this:

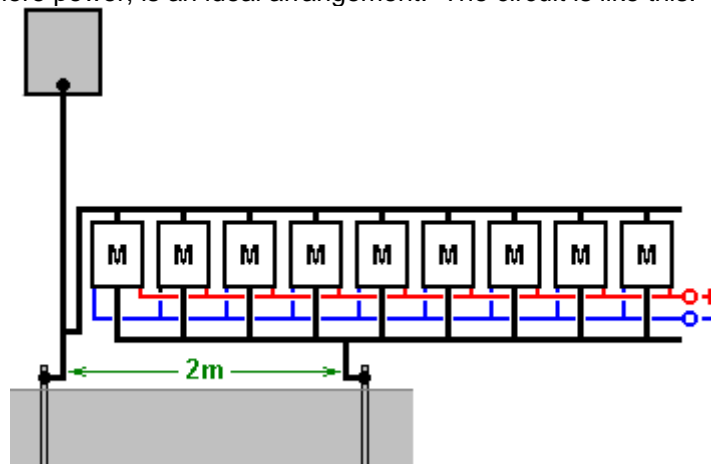

This circuit looks completely mad as the aerial input to the circuit appears to be directly short-circuited by the second earth connection. In spite of this, the circuit works very well when connected this way. Additional modules can be added without any known limit. Increased power can be had by either raising the aluminium plate higher above the ground, to say, 10 metres (33 feet), or by adding one or more additional aerial plates. As you

have a good aerial connected through to a very good earth, there has to be the possibility of the equipment being hit by lightning, and so it is recommended that a protective spark-gap is installed between the aerial and the earth, close to the circuit, so that if high-voltage is suddenly applied to the aerial, the spark gap will fire and shunt the excess power through to the earth. Alternatively, possibly a better solution is to install a standard lightning rod system a few metres away from the aerial and a metre or two higher up, so that it forms a more attractive point for a lightning strike.

Further experimentation has shown that altering the connection point for the aerial has a significant effect on the results. If the connection is made at the mid point between the aerial plate and the earth connection, it produces a greater output:

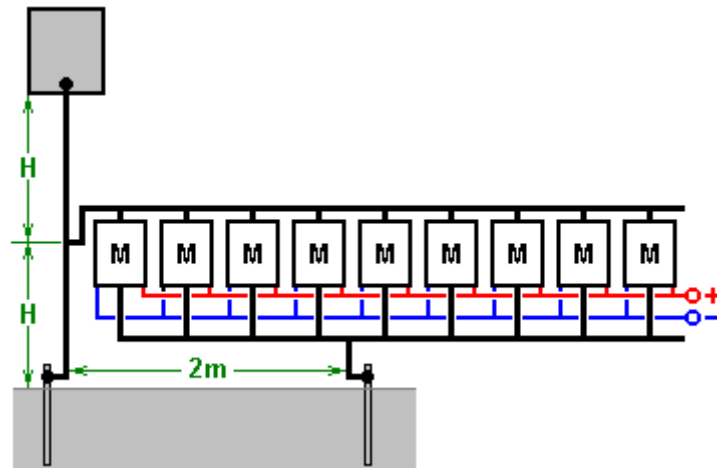

With this arrangement a single module produces around 30 volts while the original method of connecting near the earth was giving about 26 volts with two modules.

Dragan Kljajic has been experimenting with this circuit and has started by building many of these modules on a printed circuit board like this:



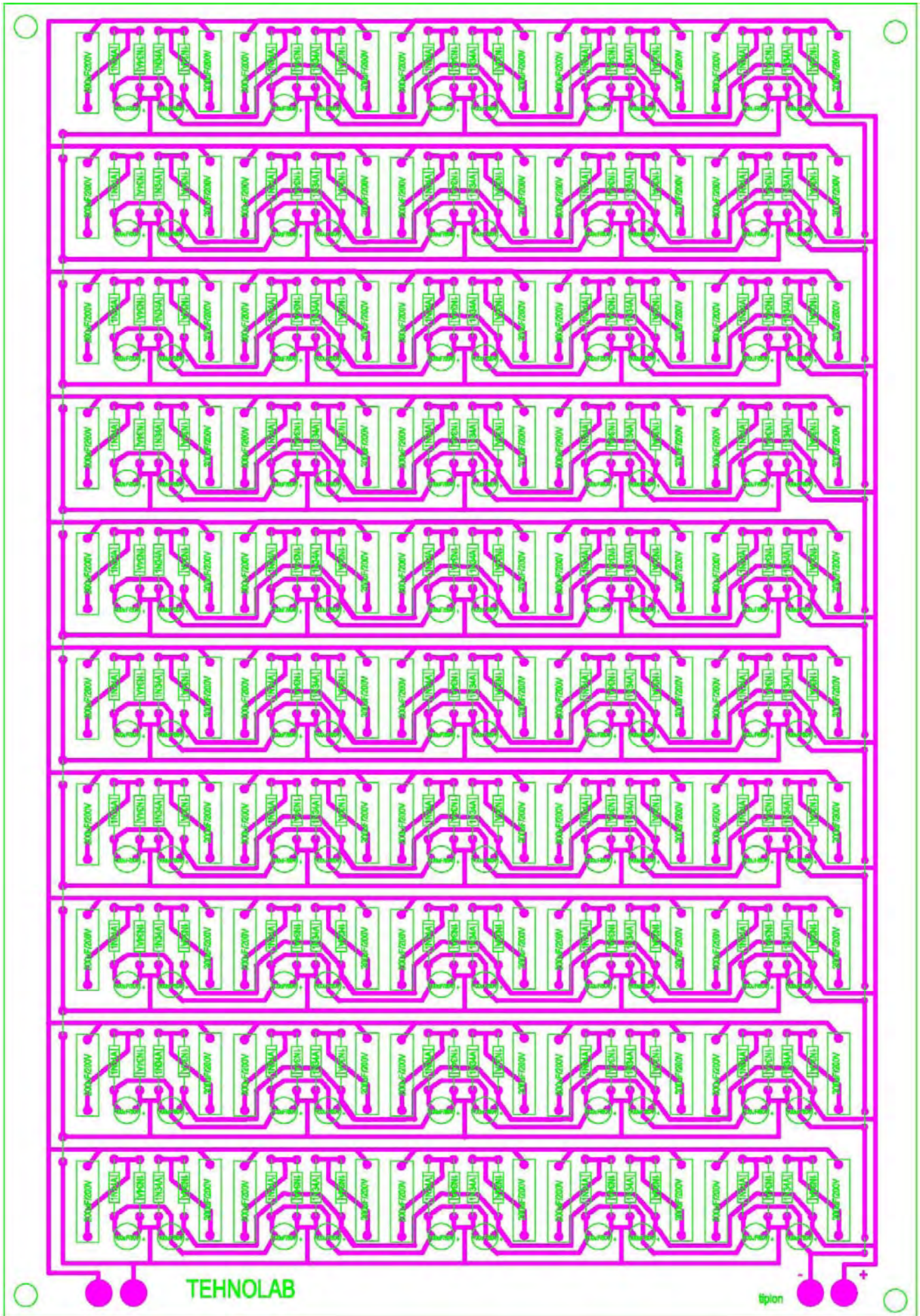

Using two of these boards, Dragan is pulling 96 watts continuously from his aerial plate. He intends to extend this arrangement much further, but is being hindered at present by a local civil war.

Here is a forum: <http://www.energeticforum.com/renewable-energy/10947-jes-ascanius-radiant-collector.html> where some builders of this system share comments. One comment is that there is an increased risk of a lightning strike where you have an earthed aerial, and so it is advisable not to place the aerial plate inside a house, but perhaps suspended between two trees. Also, using a car spark plug connected across the module set can protect against lightning strikes damaging the circuitry.

As a result of queries, Jes stresses the following points:

1. The plate **must** be high off the ground.
2. The plate **must** be polished and insulated.
3. The wire **must** be single-strand solid wire.
4. There **must not** be any part of the wire above the circuit, which is not insulated.

He further comments: you can use aluminium foil and cling film to make many collector plates 0.4 m x 5 m and connect them close together to feed the aerial wire. Remember, no uninsulated wire anywhere. Any queries should be asked on the forum shown above.

Thomas Henry Moray's Aerial System.

In this field, Thomas Henry Moray is outstanding. By 1936 he had developed a piece of apparatus which was capable of putting out high power with no human-generated input power at all.



Moray's equipment is said to have contained a germanium diode which he built himself in the days before solid-state devices became readily available. The equipment was examined and tested many times. On dozens of occasions, he demonstrated the equipment driving a bank of twenty 150W bulbs, plus a 600W heater, plus a 575W iron (a total of 4.175 kW). The power picked up by this device needed only small diameter wires and had characteristics different from conventional electricity. One demonstration which was repeated many times, was to show that the output power circuit could be broken and a sheet of ordinary glass placed between the severed ends of the wire, without disrupting the supply. This type of power is called "Cold electricity" because thin wires carrying major power loads, do not overheat. This form of energy is said to flow in waves which surround the wires of a circuit and not actually through the wires at all. Unlike conventional electricity, it does not use electrons for transmission and that is why it can continue through a sheet of glass which would stop conventional electricity dead in its tracks.

On one occasion, Moray took his equipment away from all urban areas to a place chosen at random by a critic. He then set up the equipment and demonstrated the power output, well away from any man-generated electrical induction. He disconnected the aerial and showed that the power output stopped immediately. He connected the aerial again to generate the output as before. He then disconnected the earth connection which stopped the output again. When the earth wire was connected again, the output power returned. He found that the power output level fell somewhat at night. The aerial used in his demonstrations was reported to be like this:

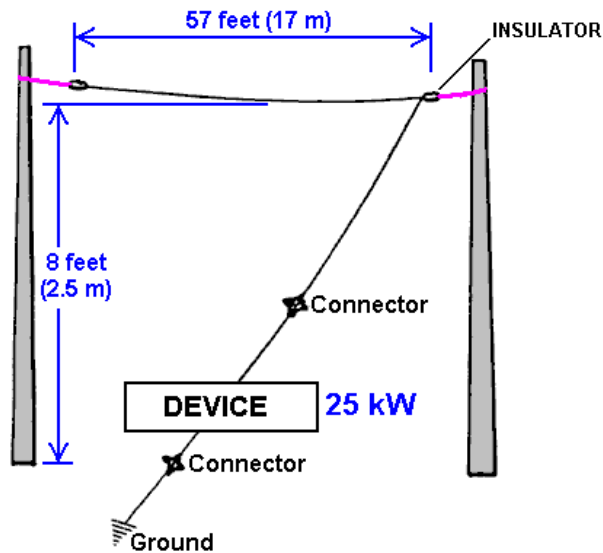

From which it can be seen that even a relatively short aerial wire suspended not far from the ground, is capable of collecting substantial amounts of usable electrical power. The earth used in the remote demonstrations was a length of gas pipe which was hammered into the ground. It was noted that as each hammer blow drove the pipe deeper into the earth, the light bulbs (which formed the electrical load) shone more brightly, indicating that the quality of the earth connection is very important when serious power is being drawn from an aerial.

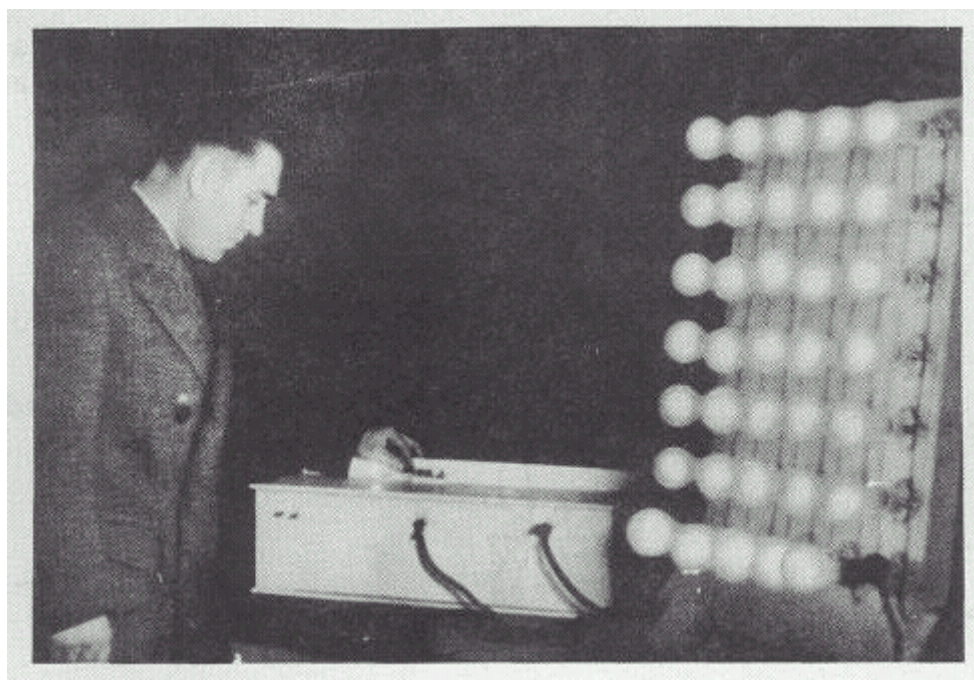

Thomas developed various versions of the device, the latest of which did not need the aerial or earth connections, weighed 50 pounds and had an output of 50 kilowatts. This device was tested in both an aeroplane and a submarine, thus showing the device to be fully self-contained and portable. It was also tested in locations which were fully shielded from electromagnetic radiation.

Moray was shot and wounded in an assassination attempt in his laboratory. This caused him to change the glass in his car to bullet-proof glass. He was threatened many times. His demonstration equipment was smashed with a hammer. When threats were made against his family, he stopped rebuilding his equipment and appeared to have turned his attentions to other things, producing a device for 'therapeutic' medical treatment.

In his book "The Energy Machine of T. Henry Moray", Moray B. King provides more information on this system. He states that Moray was refused a patent on the grounds that the examiner couldn't see how the device could output so much power when the valve cathodes were not heated. Moray was granted US Patent 2,460,707 on 1st February 1949 for an Electrotherapeutic Apparatus, in which he included the specification for the three valves

used in his power device, apparently because he wanted them to be covered by a patent. As far as can be seen, the valve shown here is an oscillator tube. Moray claimed that this tube had the very high capacitance of 1 Farad when running at its resonant frequency. Moray liked to use powdered quartz as a dielectric in the capacitors which he made, and he had a habit of mixing in radium salts and uranium ores with the quartz. These materials may well be important in producing ionisation in these tubes and that ionisation may well be important in tapping the energy field.

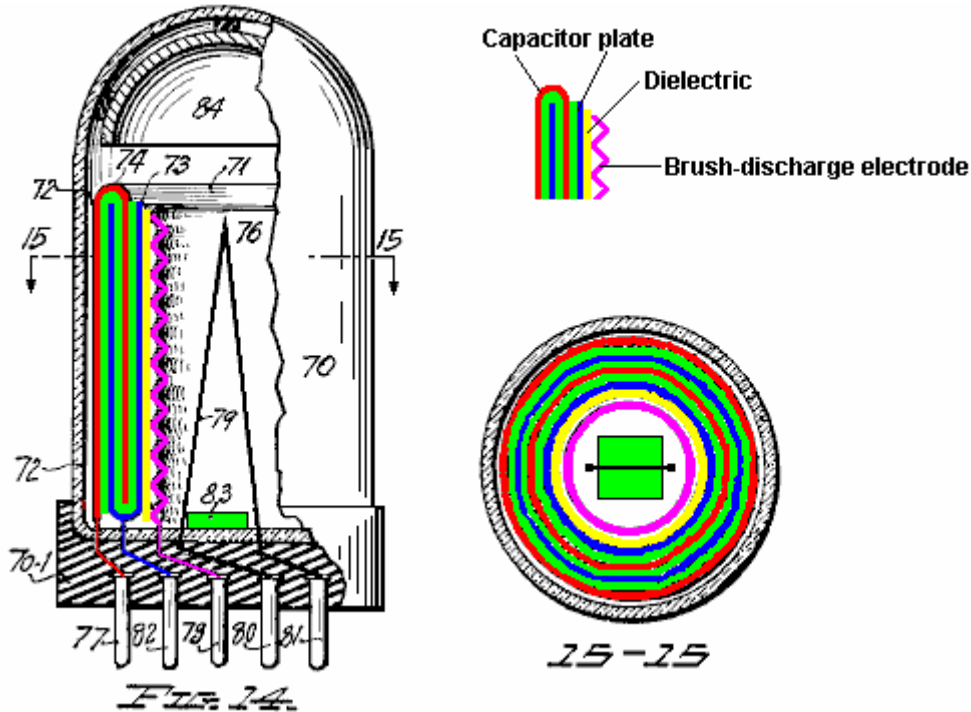

The tube shown above has a six-layer capacitor formed from two U-shaped circular metal rings with the space between them filled with a dielectric material. The plates are shown in red and blue, while the dielectric is shown in green. Inside the capacitor, there is a separate ring of dielectric material (possibly made from a different material) and an inside ring of corrugated metal to form an ion brush-discharge electrode. The capacitor and electrode connections are taken to pins in the base of the tube.

Quartz is suggested for the material of the outer covering of the tube and the wire element numbered **79** in the diagram is said to be a heating element intended to be powered by a low-voltage current source. However, as Moray had an earlier patent application refused on the grounds that there was no heating element in his tubes, it is distinctly possible that the heating element shown here is spurious, and drawn solely to avoid rejection by the examiners. In his patent, Moray refers to the capacitor in this tube as a "sparking" capacitor, so he may have been driving it with excessively high voltages which caused repeated breakdown of the capacitor material.

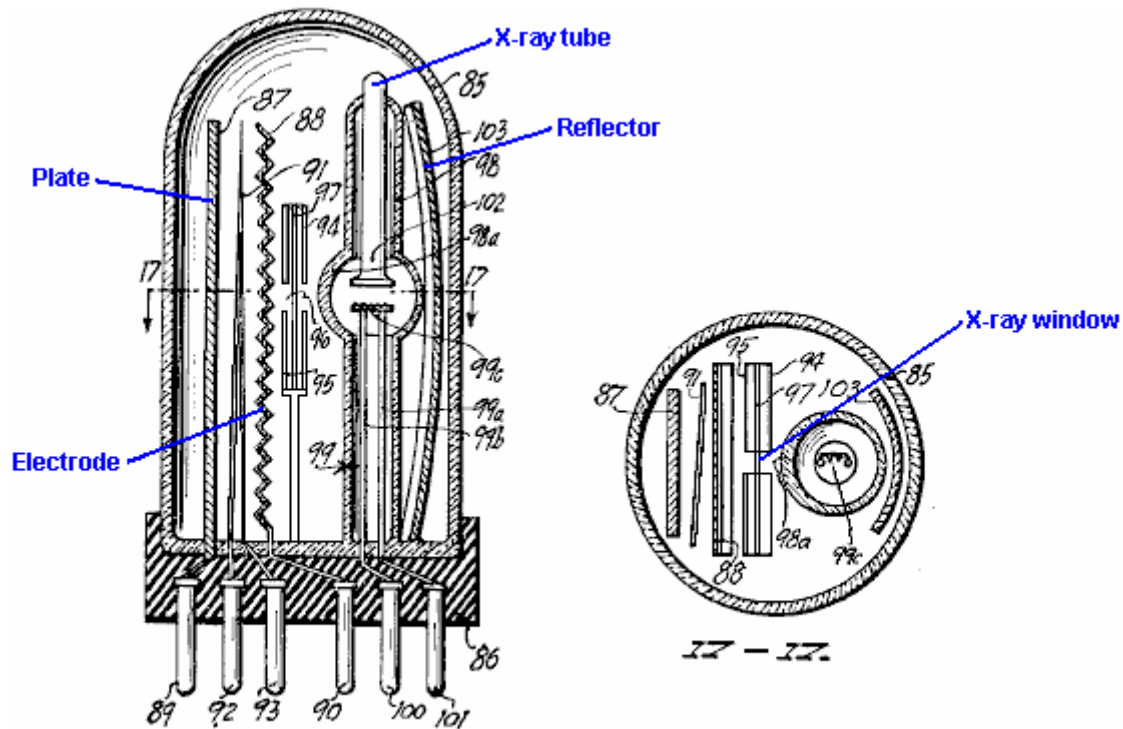

FIG. 16.

The tube of Fig.16 above, uses a different technique where an X-ray tube is used to bombard a corrugated electrode through a screen containing an X-ray window. It is thought that a brief burst of X-rays was used to trigger very short, sharp bursts of ions between the anode and cathode of the tube and these pick up extra energy with every burst.

An alternative version of this tube is shown in Fig.18 below. Here the construction is rather similar but instead of an X-ray window, a lens and reflector are used to cause the ionisation of the switching channel between the anode and cathode. In both tubes, the corrugated electrode supports a corona build-up just prior to the short X-ray switching pulse, and it is thought that the ions contribute to the intensity of the resulting pulses which emerge from the tube. Very short uni-directional pulses are capable of causing conditions under which additional energy can be picked up. From where does this extra energy come? In 1873, James Clerk Maxwell published his "Treatise on Electricity and Magnetism" and in it he pointed out that the vacuum contains a considerable amount of energy (Vol. 2, p. 472 and 473). John Archibald Wheeler of Princeton University, a leading physicist who worked on the US atomic bomb project, has calculated the flux density of the vacuum. Applying Einstein's $E=mc^2$ formula indicates that there is enough energy in every 1 cc of "empty" space, to create all of the matter in the visible universe which can be seen with our most powerful telescopes. That amount of energy is so great as to be beyond imagining. This energy field is referred to as "Universal Energy", "Cosmic Energy" or "Zero Point Energy". At this time, we do not have any instrument which responds directly to this energy and so it is almost impossible to measure.

The existence of this energy field is now widely accepted by mainstream science and it is borne out by the situation found at quantum levels. It is generally thought that this energy is chaotic in form and for useful energy to be drawn from it, it needs to be restructured into a coherent form. It appears that uni-directional electromagnetic pulses of one millisecond or less, can be used to cause the necessary restructuring as they generate an outward coherent wave of radiant energy, from which energy can be extracted for use in most electrical devices, if a suitable receptor system is used. Tom Bearden states that at the quantum level, the seething energy of this field appears continuously as positive and negative charges. As these are evenly distributed, the net charge at any point is always zero. If a "dipole" (two opposite charges near each other) is created anywhere, then it polarises the energy field disrupting the previously even distribution of charges and causing massive streams of energy to radiate outwards from the dipole.

A voltage pulse acts as a dipole, provided the voltage rise is fast enough, and that is what causes a wave of radiant energy fanning out from the location of the voltage pulse. Batteries and magnets create continuous dipoles and so cause the local quantum energy field to send out continuous streams of massive power which can be utilised if (and only if) you know how to do it. The search for mechanisms to capture and use even a tiny fraction of these energy streams is what the "free-energy" field of research is all about. Some people say that there is no such thing as "free-energy" because you have to pay for the device which captures it. That is like

taking a bus trip to a car dealership where they are giving away new cars, and saying that your new car was not a “free” car because you had to pay a bus fare to reach the car dealership.

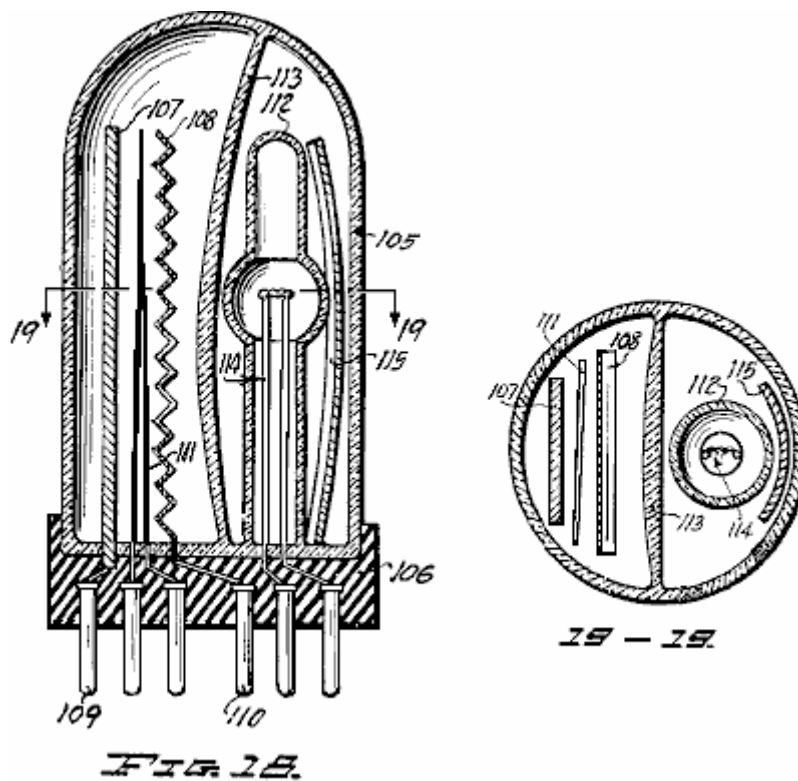

Moray King suggests that the circuit used by Thomas Henry Moray was as follows:

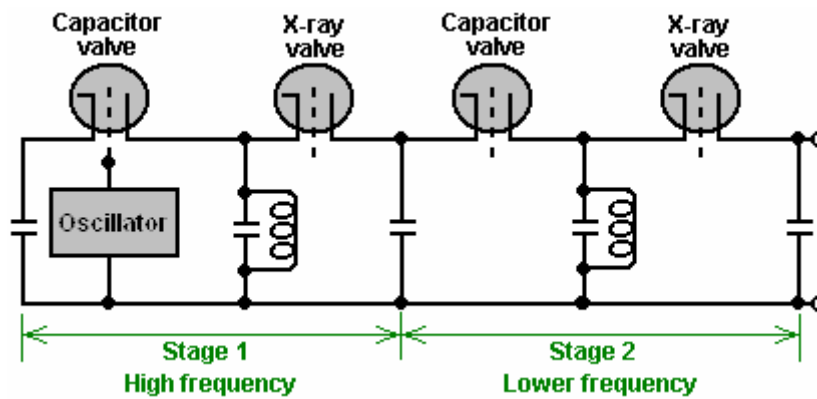

There can be little doubt that Thomas Henry Moray built several versions of his apparatus, each of which produced output power well in excess of any input power needed. It seems highly likely that most of them used no input power whatsoever, and if there were any others, they will have been powered by a tiny fraction of the output power. If mild radioactive material was used as described, then the output power could in no way be attributed to that source alone, since the output power was thousands of times greater than any power available from the radioactive materials.

It is perhaps time to explain a little more about, voltage, power and current. We have been raised with the notion that it is necessary to “burn” a fuel to get power, that batteries “run down” when used and that you have to keep turning the shaft of an electrical generator to be able to draw current from it. These things are not actually true. The relatively recent field of Quantum Mechanics shows that if a charge, such as an electron has, is positioned in what is supposed to be “empty” space, it is not alone. The “empty” space is actually seething with energy, to the extent that “virtual” particles are popping into existence for a fraction of a second and then disappearing again. They are called “virtual” because they exist for such a short time.

Because of the negative charge of the electron, the particles appearing and disappearing around it will all be positive in charge. The electron has “polarised” the space around itself because it has a charge. The instant that a positive “virtual” particle appears, there are two charges near each other - minus on the electron and plus on the

particle. When you have two opposite charges near each other, they form a "dipole". Dipoles form a gateway through which energy from the environment flows continuously. An instant later, the particle disappears, but its place is immediately taken by another virtual particle. The result is a continuous stream of energy flowing out from the dipole.

Batteries with their positive and negative terminals are electrical dipoles, so too are generators when the input shaft is spun. Permanent magnets with their North and South poles are magnetic dipoles. Both of these have continuous streams of energy flowing through them. So, why then do batteries run down and lose their charge? The reason is that we power circuits using a closed loop. The energy flowing out of one terminal flows into the opposite terminal and instantly destroys the dipole. A new dipole has to be created every split second if the circuit is to deliver power, and it is that self-destructive method of use which causes the battery to discharge or which needs the generator shaft to be rotated continuously.

If a different operating technique is used, where the dipole is not continuously destroyed, then devices which can provide a continuous stream of energy drawn from our natural environment can be constructed. This is not magic, just the next step in conventional science and engineering. Thomas Henry Moray managed it, initially with an aerial and earth like a crystal set to provide the dipole, his device was able to draw many kilowatts of power from the environment. No fuel was needed, the energy is already there surrounding us all, all of the time. As far as I am aware, nobody has managed to replicate Moray's device (which was the reason for it being violently suppressed) but knowing that it existed and was repeatedly demonstrated to work perfectly well, is useful in that it shows that it is possible to tap the massive zero-point energy field with a practical, home-constructed device.

Here is a collection of additional items of information gathered from several different sources:

Moray started his experiments with 'the taking of electricity from the ground', as he described it, during the summer of 1909. By autumn 1910 he had sufficient power to operate a small electrical device, and demonstrated his idea to two friends. The early stages of this demonstration consisted of operating a miniature arc light. It soon became clear to him that the energy was not static and that the static of the universe would be of no assistance to him in obtaining the power for which he was searching.

During the Christmas Holidays of 1911, he began to realise fully, that the energy with which he was working, was of an oscillating nature. He also realised that the energy was not coming out of the earth, but instead, was coming to the earth from some outside source. These electrical oscillations in the form of waves were not simple oscillations, but were surging like the waves of the sea, coming continually to the earth but more in the daytime than at night, but always arriving as vibrations from the reservoir of colossal energy out there in space. By this time Moray was able to gather enough power to light a 16-candlepower carbon lamp to about a half of its capacity, but he did not manage to gain any further improvement until the spring of 1925.

In 1912 Moray was called to go on a mission for the Church of Jesus Christ of Latter-Day Saints, and under a visitor's visa was allowed to enter Sweden during the Exhibition of 1912 in Stockholm. In his notebook, dated November 1, 1913, he included a note saying that he had obtained material from a railroad car at Abisco, Sweden the previous summer, also some more material from the side of a hill. He made electric tests of these materials, taking them home to try each as a detector for his energy machine. Tests indicated that this soft, white stone-like substance might make a good "valve-like detector". This "valve-like detector" is what led him to do research into semi-conductive materials, and from this soft white stone he developed his first valve and the valve which was used in some of his early Radiant Energy devices (silver wire touching a stone can act as a rectifier).

Moray demonstrated that energy was available by its actions on a resistive load, such as a flat-iron or a space heater, and by lighting bulbs. A resistive device acts as a load which is directly proportional to the amount of energy delivered to it. In heating a heater, or lighting a bulb, the number of watts produced can be calculated as equal to the number of watts provided to the device. This energy is fed into a load to give either heat, light, or power. A motor can be operated but it must be designed to run on a high frequency power supply. The Radiant Energy device used an antenna and a ground connected to his solid state Radiant Energy circuit:

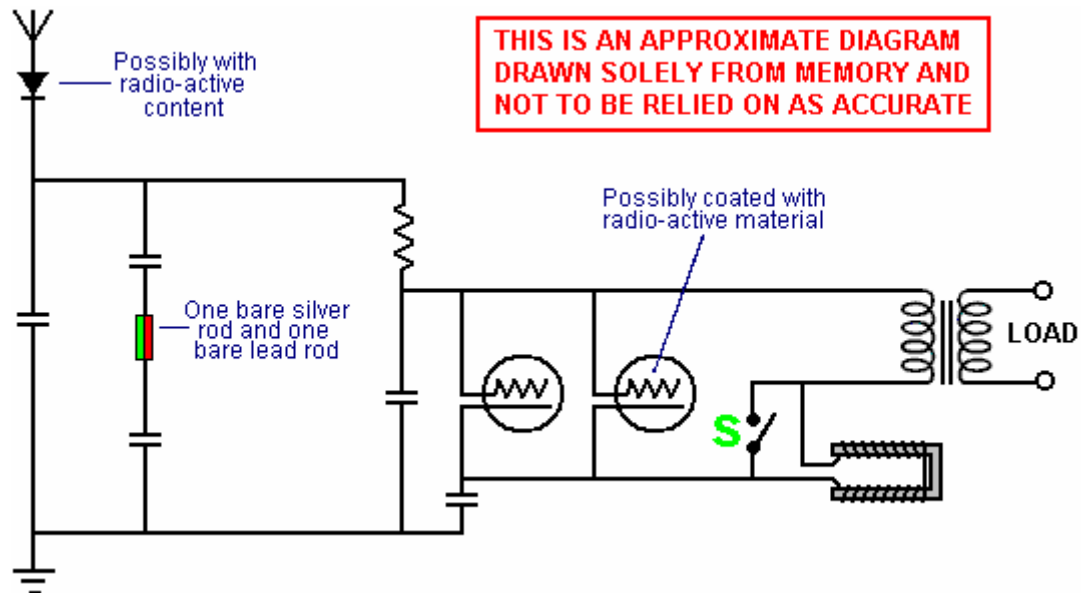

THIS IS AN APPROXIMATE DIAGRAM
DRAWN SOLELY FROM MEMORY AND
NOT TO BE RELIED ON AS ACCURATE

The diagram shown above is reproduced from a rough sketch drawn from memory after seeing Moray's circuit diagram. The person who drew it does not understand how the circuit works, so please treat this diagram as being just an overall suggestion as to what Moray's circuit might have been like. It is actually much more likely that it was a cascade of pairs of tank circuits containing Moray's valve, each pair being one series tank circuit followed by one parallel tank circuit, the oscillating frequency dropping with each tank pair and the output power rising with each tank pair. Moray's circuit was started oscillating by stroking the U-shaped coil with a permanent magnet for a few seconds, and when the circuit started operating, then switch 'S' was closed, effectively removing the U-shaped coil from the circuit.

Moray was able to demonstrate that none of the output energy came from within his device. Internally the device was electrically dead when it had not been connected and tuned to the antenna. When his device was set up, he could connect it to an antenna and ground, and by priming it first and then tuning it as he primed it, the device would draw in electrical energy. This high frequency electrical energy produced up to 250,000 volts and it powered a brighter light than witnesses had ever seen before. Heavy loads could be connected to the device without dimming the lights already connected to it. This device worked many miles from any known source of electrical energy such as power transmission lines or radio signals. The device produced up to 50,000 watts of power and worked for long periods of time.

Moray initially assumed that this energy was electromagnetic in nature however, he never claimed that it was. He assumed at first that this energy came from the earth but later he believed it was flowing in from the universe. Finally he began to believe that it was present throughout all space, intermolecular space as well as terrestrial and celestial space. He did not necessarily understand how his detectors operated, only that if he built the device very carefully according to his calculations it would work. He was able to demonstrate the existence of an energy that today, though it has not been identified or proven, has been theorised by many researchers.

The largest instrument was about 6 inches high, circular in shape and about 8 inches in diameter. We went out on the roof of the chicken coop carrying the device on a small drafting board, erected an antenna upon the roof of the coop, the antenna being about 100 feet from the house. We pulled the main line switches in the house before going out upon the roof. Mr Judd had Moray move the drafting board from place to place and he also examined the inside of the coop for hidden equipment. The machine was then assembled in his presence and the device was started. Mr Judd timed me to see how long it would take to bring get the light operating. I was able to light the CGE lamp to its full brightness and to heat an old-style Hotpoint electric flat iron to sizzling point, which required 655 watts. Mr Judd asked for the antenna to be disconnected. When this was done, the light went out. The aerial was connected again and the light reappeared. We drove a new grounding rod at a spot selected by Mr Judd, made a connection to the new grounding point and the light burned dim, but came brighter and brighter as the new grounding rod was driven deeper and deeper into the ground.

If the ground or antenna is left disconnected for too long a time, the device becomes electrically dead and must be retuned in order to regain the energy flow. Dr Eyring found no fault with the demonstration and the worst that he could say about it was that it might be induction, but that if Moray would take the device out in the mountains away from all power lines, a distance of three or four miles, and it then operated, he would then acknowledge that it could not be induction and that his theory was wrong.

At last they decided to go up Emigration Canyon, as there are no power lines in that canyon. All three gentlemen were very well satisfied and pleased with what they saw. The antenna wire was put up without any aid or instructions whatever from Mr Moray, except that he suggested that the wire be stretched tighter to prevent so much sag at the centre. This was done and the wire then appeared to clear the ground by about 7 or 8 feet at its lowest point. The ground pipe was of half-inch water pipe consisting of two sections. The lower section was pointed at the end to make its driving into the creek bed easy. It was about 6 feet long and after being driven down about 5 feet the second section, which was about 4 feet long, was screwed on with a wrench and the pipe driven further down until it struck a hard object, so about 7 feet of pipe was in the ground.

The antenna wire was insulated from the poles with two glass insulators about 6 inches long and having holes in both ends. A piece of wire about 2 feet long connected each insulator with the pole. The lead-in wire was fastened to the antenna wire at a point about 10 or 15 feet from the east pole. I helped Mr Moray solder the connection. I paced the distance between the two antenna poles and estimated it to be 87 feet. Mr Moray's equipment, apart from the antenna and ground wires, consisted of a brown box about the size of a butter box, another slightly smaller unpainted box, a fibre board box about 6" x 4" x 4", which Mr Moray referred to as containing the tubes, and a metal baseboard about 14" x 4" x 1" containing what appeared to be a magnet at one end, a switch near the middle and a receptacle for an electric light bulb at the other end. There were also several posts for connecting wires on the baseboard.

When all of the wires were connected and everything was ready, Mr Moray began tuning in. Before tuning, he placed the key on the post: he said it would be in contact while the light burnt, but no light appeared. The tuning consisted of stroking the end of a magnet across two metal projections protruding from what I referred to above as being 'a magnet'. After tuning for slightly more than 10 minutes the key was put on the operating post and the light appeared immediately. Mr Moray put the key on the operating post two or three times before during the tuning operation but no light appeared. We allowed the light to burn for 15 minutes. In my opinion, the brilliance of the light coming from the 100-watt bulb, was about 75% as bright as a 100-watt bulb connected to an ordinary house socket. It was an steady light, without fluctuations of any kind.

While the light was burning Mr Moray disconnected the antenna lead-in wire from the apparatus and the light went out. He connected it again and the light appeared. He also disconnected the ground wire and the light went out. He then connected it and the light appeared again.

In another demonstration, Mr Moray opened the device and let everyone see everything except one small part that he placed his hand over and hid in his fist. This part he cut off and put in his vest pocket. Everything else, people were allowed to examine to their hearts' content. "If that part is able to make such power itself, then it's some device and worth selling. Such a battery would be worthwhile", were some of the remarks made.

On several occasions Dr Moray would disconnect the antenna wire momentarily, but not long enough to lose the light. In disconnecting and connecting the antenna wire a flash of electricity could always be seen at the

At a demonstration in 1928, the aerial used was about 200 feet long and positioned about 80 feet above the ground: the wire is a copper cable approximately a quarter of an inch in diameter, and well insulated. The earth connection used was the water pipe in the basement of Dr Moray's home. The device was assembled in a trunk through the sides of which were holes for the connections to ground and to the antenna and for observation; the holes were about one-half inch in diameter. There were two boxes about 10 by 20 by 4 inches, one on top of the other; both were closed and the covers fastened with screws. On the upper box was lying an insulating panel about an inch thick by 15 inches long and 3 inches wide; it was made of slate or hard rubber or some material of similar appearance. On this were two binding posts which could be connected together by a small switch; also mounted on this panel was an object about 2.5 inches square, wrapped in friction tape, from which protrude two poles about 1/4-inch in diameter, apparently of sift iron. Two light bulb sockets were connected in the circuit. In one of these there was a 20-watt bulb, and in the other a 100 watt bulb.

Dr Moray then took a magnet, which was a very broad, short limbed U, and began to stroke one pole of it on the poles in the taped body. Mr Jensen placed his fingers on the binding posts several times, and at last received a rather vigorous shock. Mr Moray then threw the switch and the bulbs lit up. As a further proof that the conversion of the energy was due to the mechanism in the box, Dr Moray hit the table on which the trunk was standing, a moderate blow with a hammer whereupon the light flickered and went off, due to the detector being shaken out of adjustment. The boxes, in which the mechanism had been housed during the test, were opened and the contents examined. There were capacitors, the detector, a transformer, and two tubes in them but nothing else. Nothing that in the least resembled a battery.

It is to be noted that after a total run of 158 hours the device supplied 635 watts; inasmuch as a horsepower is but 746 watts this equals 0.878 of a horsepower or slightly more than 7/8 horsepower. This alone is sufficient to dispose of any suggestion of a battery.

A report from 1929 says: It is now more than 2 years since I first became acquainted with Dr T. H. Moray and the work he is carrying on, and in that time he has demonstrated inventive ability of an exceptional order. Perhaps the most wonderful of his inventions is a device whereby he is able to draw electric power from an antenna. This energy is not derived by induction from power lines, as has been suggested by some, nor is it derived from radio stations, as has been demonstrated by taking the apparatus more than 26 miles from the nearest power line and over a hundred miles from the nearest radio station and showing that it operates just as well as anywhere else.

This device was subjected to an endurance test in which it was operated continuously for a week, and at the end of that time a 100-watt lamp was lighted simultaneously with the heating of a 575 watt standard Hotpoint flat iron, making a total of 675 watts; it is very evident that no batteries could sustain such a drain as this.

He has also invented a very sensitive sound detector whereby it is possible to hear conversations carried on in an ordinary tone of voice at a distance of several blocks. He has also worked out numerous radio hook-ups which eliminate many of the parts now considered necessary for good reception, yet there is no diminution in quality or volume; in fact, there is a notable elimination of interference from static when some of these are used. He has devised a means by which he is able to measure with some degree of accuracy the energy evolved during mental activity; that is, he gets definite, variable deflections of the needle of a sensitive galvanometer which appeared to be related to the vigour of mental activity. There are a great many other equally remarkable things which he has done, such as reducing old rubber from truck tires to the state of a viscous fluid which is readily vulcanisable without the addition of smoke sheet as is necessary with other processes; also a high frequency therapeutic device, and numerous other devices which show great ingenuity.

The 6 lamps are set up in parallel and a small diameter wire is used as the current enters the tube prior to and connecting with the step-down transformer, this takes the very high voltage to the transformer. This voltage will jump across a spark gap of at least six inches. The operating frequency is so high that I have no instrument in my laboratory that is able to measure the amperage or the voltage at this frequency. (Signed, Murray O. Hayes, PhD.).

Dr Milton Marshall was attempting to identify the material that Moray called his "Swedish Stone". Moray described the radio detector which he had developed. He compared it to what was commonly known as the crystal of a crystal set. However, his detector was superior since it could drive a loudspeaker without the use of a battery. He used the most easily demonstrated device, the germanium diode, that worked on the same principle to illustrate how he thought the Radiant Energy Detector worked (Moray originally built the radio simply for the purpose of showing how he was able to pick up radio signals with a solid-state device, producing sufficiently strong signals which could drive a loudspeaker, which was something unheard of in that day. His circuit did not have batteries, and it was very similar to the old crystal-set circuitry.

The device was housed in a wooden box something like 12" by 18", with an antenna and a ground going into it. Wires leading out of the box led to a bank of some forty 100-watt light bulbs and to an electric iron. Moray touched a switch at the top of the box with a hand electrostatic plate and the globes all lit up brilliantly. We all noted that the bulbs burned cold except each had a hot spot about the size of a dime on the top slightly off centre. I also recall that I could turn the lights on and off by approaching and retreating to and from the device, either with my whole body or my hand. If my memory is clear, the machine had to be tuned with a dial to be placed in this condition. (Chester M. Todd, 1971)

In 1938, after examining the transformer of the device, Mr E. G. Jensen stated that he considered that the amount of current which he had seen taken from the device was positive proof that the current developed by or in the machine was different to any in use at that time. This was because the transformer would have burned out if it had been carrying normal current, but the transformer showed no signs of even ever having been warm. He was informed by Dr Hayes that the transformer had been in use under the same loading conditions during many demonstrations in the past.

The "Number 1" capacitor consisted of two small sheets of aluminium of about 30 gauge, separated by and making contact with a piece of one-quarter inch thick plate glass. The plate glass was larger than the aluminium sheets and overlapped them.

The "Number 2" capacitor was a commercial unit manufactured by Igred Condenser & Mfg. Co. and had a capacity of 0.025 mfd.

They were used as shown here:

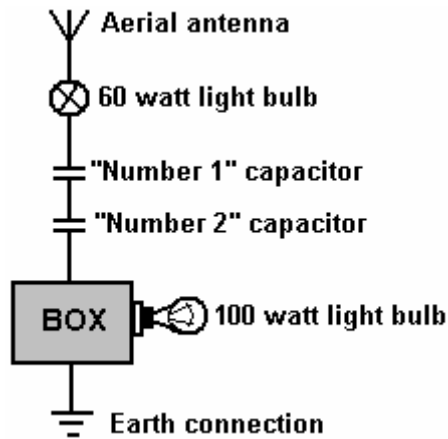

With the 60 watt lamp and the two capacitors attached to the antenna and the antenna and ground attached to the box containing the Radiant Energy equipment as shown in the sketch, the 100-watt lamp on the secondary or output side was lighted. Unscrewing the 60-watt lamp from its socket caused the 100-watt amp to go out, but it immediately lighted when the 60-watt lamp was screwed into its socket again. The 60-watt lamp did not light. Shorting the antenna and ground by placing a wire across them, caused the 100-watt lamp to go out. Similar shorting with the hands also caused the 100-watt lamp to go out. No electricity could be felt when shorting with the hands. If either the ground or the antenna wires were disconnected from the box, the 100-watt lamp would go out. Neither of the capacitors or the 60-watt lamp on the primary side of the box were necessary but were simply put there to show that the high frequency power will jump or pass through them.

Moray's patent application on this device was filed in 1931 and rejected on a number of grounds. Firstly, "Because no means was provided for causing the cathode to emit an appreciable number of electrons, the current produced in the cathode by the antenna will not heat the cathode to a temperature at which an appreciable number of electrons per second are emitted". In other words, according to Thomas E. Robinson, Commissioner of Patents, a solid state device, such as a transistor, cannot possibly work. Secondly, because "No natural source of electric wave energy is known to the Examiner and proof of the existence of such a source is required". In other words, it was not enough for Moray to demonstrate the effect of the energy source; he also had to identify it, which he could not do. None of the original patent applications that Henry made are any longer available at the US Patent Office. Although their file jackets are there, the contents and applications themselves are gone.

In 1942, Moray attempted to rebuild a Radiant Energy device, using the remaining bit of what was known as the "Swedish Stone". This material, which was the heart of his original RE detector, he had never managed to duplicate, and the shortage of this material limited the amount of power which he could draw. Consequently, in the large unit, he developed a second detector that forced him into extensive research involving nuclear materials and radioactive reactions. He became deeply involved in the study of synthetic radioactivity as described by Gustave LeBon in his book "The Evolution of Matter". The years slipped by and Moray spent most of his time working on what he called the "counter-balance" to eliminate the need for an aerial antenna.

Moray said:

Enough energy is coming to the earth to light over 1,693,600 100-watt lamps for every human being on the earth today. No fuel of any kind need be taken as this energy can be picked-up directly by ocean liners, railroads, airplanes, automobiles, or any form of transportation. Heat, light and power can be made available for use in all kinds of buildings and for all kinds of machinery. An example would be to pump water onto the desert lands, the power source being only a fraction of the weight of any steam plant or any kind of engine in use today and all this at a fraction of the current cost.

The total energy involved in "cosmic" radiations is very large. The mechanism of its generation involves a basic relationship with the total structure and action of the universe. Today it is believed that cosmic radiation consists primarily of protons and some heavier nuclei. At times this cosmic energy packs a wallop of around 100 quadrillion volts. Coming continuously with slight variations in time, the radiations have a uniformly directional isotropy. The earth is, therefore, surrounded in an atmosphere of radiation with cosmic rays coming continually to the earth from all directions, although there may be a slight deflection of the weaker rays by the earth's magnetic field. There is every indication that our sun is not the source of any appreciable amount of this radiation. The origin, therefore, is from the universe as a whole. The total energy of cosmic radiation is more than the entire luminous output of all the stars and nebulae of the universe combined. Unlimited power is being delivered to everyone's doorstep.

The Moray Radiant Energy discovery, using radiations from the cosmos as its power source, gives the greatest amount of energy per pound of equipment of any system known to man. Electrical power through an electric

motor or an electric jet far exceeds any form of energy in any engine in the delivery of power. There is no dead centre of lost motion in an electric motor nor loss of push in an electric jet. Also, the starting torque is much higher in the electrically powered engine than in the combustion engine.

Harnessing cosmic energy is the most practical method yet discovered by man. Furthermore, it is possible to utilise this vast source of energy from the universe without a prime mover at any point on the earth --- on the ground, in the air, on the water, under the water, or even underground. If one considers that an electrical generator is not in the true sense a generator - as electricity is not made by the generator - but is merely an electrical pump, the Moray Radiant Energy device may then be referred to as a cosmic ray pump: that is, a high speed electron oscillator serving as a detector of cosmic radiations which causes a pumping action or surging within its circuitry.

To account for the propagation of heat and light - two of the forms of Radiant Energy - man has postulated the existence of a medium filling all space. But, the transference of the energy of radiant heat and light is not the only evidence in favour of the existence of such a medium. Electric, magnetic, and electromagnetic phenomena and gravitation itself point in the same direction.

Attractions and repulsion take place between electrified bodies, magnets, and circuits conveying electric currents. Large masses may be set in motion in this manner, acquiring kinetic energy. If an electric current is started in any circuit, corresponding induced currents spring up in all very closely neighbouring conductors. To originate a current in any conductor requires the expenditure of energy. How, then, is the energy propagated from the circuit to the conductors? If we believe in the continuity of the propagation of energy - that is, if we believe that when it disappears at one place and reappears at another it must have passed through the intervening space and, therefore, have existed there somehow in the meantime - we are forced to postulate a vehicle for its conveyance from place to place.

When a particle is electrified, what one must first observe is that a certain amount of energy has been spent; work has been done. The result is an electrified state of the particle. The process of electrifying a conductor is, therefore, the storing of energy in some way in or around the conductor in some medium. The work is spent in altering the state of the medium, and when the particle is discharged, the medium returns to its original state, and the store of energy is disengaged. Similarly, a supply of energy is required to maintain an electric current, and the phenomenon arising from the current are manifestations of the presence of this energy in the medium around the circuit. It used to be that an electrified particle or body was supposed to have something called "electricity" residing upon it which caused electrical phenomena. An electric current was regarded as a flow of electricity travelling along a wire (for example), and the energy which appeared at any part of a circuit (if considered at all) was supposed to have been conveyed along the wire by the current. But, the existence of induction and electromagnetic interactions between bodies situated at a distance from each other leads one to look upon the medium around the conductors as playing a very important part in the development of these electrical phenomena. In fact, it is the storehouse of the energy.

It is upon this basis that Maxwell founded his theory of electricity and magnetism, and determined the distribution of the energy in the various parts of an electric field in terms of electric and magnetic forces. The medium around an electrified body is charged with energy and not of an imaginary electric fluid distributed over the electrified body or conductor. When we speak of the charge of an electrified conductor we are referring to the charge of energy in the medium around it, and when we talk of the electric flow or current in the circuit we are referring to the only flow we know of, namely, the flow of energy through the electric field within the wire.

The work in producing the electrification of a conductor is spent on the medium and stored there, probably as energy of motion. To denote this we shall say that the medium around the conductor is polarised, this word being employed to denote that its state or some of its properties have been altered in some manner and to a certain extent depending on the intensity of the charge. If the charge is negative the polarisation is in the opposite sense, the two being related, perhaps, like right-handed and left-handed twists or rotations.

Now consider the case of a body charged alternately, positively and negatively in rapid succession. The positive charge means a positive polarisation of the medium, which begins at the conductor and travels out through space. When the body is discharged the medium is once more set free and resumes its former condition. The negative charge now induces a modification of the medium or polarisation in the opposite sense. The result of alternate charges of opposite sign is that the medium at any point becomes polarised alternately in opposite directions, while waves of opposite polarisations are propagated through space, each carrying energy derived from the source or agent supplying the electrification. Here, then, we have a periodic disturbance of some kind occurring at each point, accompanied by waves of energy travelling outwards from the conductor.

The phenomenon of interference leads to the conclusion that light is the result of periodic disturbances or vibrations of the medium, but as to the nature of these vibrations, as to the exact nature of the periodic changes or what it is that changes them, we possess no knowledge. We know that alternating electric charges are

accompanied by corresponding changes of state or vibrations of the medium, and if the charge is varied periodically and with sufficient rapidity, we have a vibration at each point analogous to, perhaps identical with, that which occurs in the propagation of light - a combination of wave and particle properties. This then is the electromagnetic theory of the luminous vibration.

In the older elastic-solid theory, the light vibrations were supposed to be actual oscillations of the elements or molecules of the medium about their positions of rest, such as takes place when waves of transverse disturbance are propagated through an elastic solid. Such limitation is unwarranted to some extent, but one cannot afford to entirely disregard the particle theory of light either. A combination of the theories has merit. We know that the change, disturbance, vibration, polarisation, or whatever we wish to term it, is periodic and transverse to the direction of propagation. The electromagnetic theory teaches us nothing further as to its nature, but rather asserts that whatever the charge may be, it is the same in kind as that which occurs in the medium when the charge of an electrified body is altered or reversed. It reduces light and heat waves to the same category as waves of electrical polarisation. The only quality of the later required to constitute the former is sufficient rapidity of alteration. These speculations were given the strongest confirmation by experiments of Prof. Hertz many years ago.

When a resilient substance is subjected to strain and then set free, one of two things may happen. The substance may slowly recover from the strain and gradually attain its natural state, or the elastic recoil may carry it past its position of equilibrium and cause it to execute a series of oscillations. Something of the same sort may also occur when an electrified capacitor is discharged. In ordinary language, there may be a continuous flow of electricity in one direction until the discharge is completed, or an oscillating discharge may occur. That is, the first flow may be succeeded by a backrush, as if the first discharge had overrun itself and something like recoil had set in. The capacitor thus becomes more or less charged again in the opposite sense, and a second discharge occurs, accompanied by a second backrush, the oscillation going on until all the energy is either completely radiated or used up in heating the conductors or performing other work.

When capacitors are filled with energy captured by the Moray Radiant Energy device and then discharged through a circuit of proper impedance, reactance and inductance, thereby synchronising the oscillation of the device with those of the universe, electrical inertia is set up. In the reversal of the current, the capacitors are charged, discharged and recharged slowly until the energy stored in them is radiated in kinetic energy through the device, and this energy can be kept alive indefinitely by establishing resonance with the oscillations of the universe.

Considering oscillations from a mechanical, electrical and mathematical point of view, we find that electrical resistance is the same as mechanical friction and current is comparable to mechanical velocity. Inertia and inductance may then be considered analogous terms. In mechanics the greater the inertia of a body, the longer it will stay in motion. In the Radiant Energy device's resistance-inductance-capacity (REC or RLC) circuit, the greater the electrical inductance, the longer the current continues to flow once it is established by synchronisation with cosmic surges.

Expressed mathematically, the equations are the same for electrical or mechanical phenomena. Which means, that $R < \sqrt{4L / C}$, where R is the resistance in ohms, L is the inductance in henries, and C is the capacitance in farads. When this is true, an oscillatory discharge will occur and a very powerful inductance inertia will assert itself. For low values of R, the frequency of the oscillations can be shown by $f = 1/2 \pi \sqrt{CL}$. The rapidity of the oscillations is governed by the capacitance and inductance.

In the vibrational forces of the universe, we find the key to the source of all energy. How we can utilise this energy for modern industry without being limited to mechanical prime movers is the question. And, the answer may be an energy generator, balanced so as to oscillate in synchronisation with the oscillations of the universe.

Dr Ross Gunn, a civilian scientist for the US Navy, stated years ago that the earth is a huge generator, generating over 200 million amperes of electric current continuously. For example, the aurora borealis is considered to be a very large definite electrical phenomenon produced by the passage of electric charges through the rarefied gases of the higher atmosphere. The earth has since been shown, by Dr Gunn and others, to have a negative charge amounting to 400,000 coulombs. Yet, six feet above the ground the air is charged with more than +200 volts with respect to the ground.

It is known that air conducts electricity away from charged objects. This being true, how does the earth maintain its charge since it is a charged object exposed to the surrounding atmosphere? If the air conducts electricity, the earth's charge must be constantly passing into the atmosphere. And it has been calculated that the earth has a continuous discharge into the atmosphere of 1,800 amperes. At this rate, the earth should lose 90% of its charge into the air in one hour, yet the earth's charge does not diminish. From where does the earth's energy come?

The conversion of matter to energy in the stars is accepted, and, reasoning from what occurs in radioactive disintegration during which energy waves are radiated, one may conclude that energy waves of very high

frequency are sent out from the stars (one of which is our sun). Now, of course, the conversion of energy into matter must equally be accepted.

It has been found that ionisation, which could be the medium for the flow of energy, increases with increasing altitude, instead of decreasing as would be expected. Since the source of energy is the universe, the generation of energy by rotary action and by all prime movers is an effect and not a cause. Oscillatory energy action, be it in a Leyden jar, another man-made capacitor, or in what we may call natural capacitors, always behaves the same. The oscillations will continue until they have reach their cycle of height and then there will be a backrush returning to where the oscillations originated. Every oscillation, whether large or small, is completed during the same interval of time. These oscillations all prove the same great fact, that they are governed by the same cycle of time, completed during the same interval of time. Waves of energy have a regular beat note, coming and going as the waves of the sea, but in a very definite mathematical order - coming to the earth from every direction with a definite rhythm.

Energy has a definite elastic or resilient rigidity and density, which is subject to displacement and strain. When strain is removed, the medium will spring back to its old position and beyond, surging back and forth, and will continue to oscillate until the original pressure is used up. If the internal impedance is too great, there will be no oscillations, but it will merely slide back in a dead beat to its unrestrained state.

By cutting down resistance to a minimum and synchronising the resilient ionic actions of the Moray device with the wave actions of the universe, periods of oscillation can be made to come quicker and quicker until inertia asserts itself, thus lengthening out the time of final recovery. This is done by carrying the recoil beyond the natural oscillations and prolonging the vibrations by capturing the in oscillatory action. When the recovery becomes distinctly oscillatory, a harmonic pattern is initiated and the oscillations continue, resonance thereby being established with the universe.

In the universe we see the same laws being obeyed as in our laboratories. As one traces down to the almost infinitesimal constituents of the atom, one finds that matter does not exist at all as the realistic substance which we have supposed it to be. There at the very foundation, it consists of nothing more than energy charges emitted at various wavelengths or frequencies. It is becoming more and more certain that the apparent complexity of nature is due to our lack of knowledge. And, as the picture unfolds, it promises a marvellous simplicity.

One of the most marvellous relationships that has ever been revealed in the entire science of physics is that between light and electricity and the existence of electronics in atoms of matter. Knowing what we do at the present time with regard to the structure of atoms, this relationship is not quite so surprising. However, considering the total absence of this knowledge about a half century ago, the discovery that light, and radiation in general, are vibratory phenomena was revolutionary.

Speaking of radiation, "Radiant" here means proceeding from a centre in straight lines in every direction. Energy is internal and inherent. "Energy" is defined as a condition of matter, by virtue of which, any definite portion may affect changes in any other definite portion. This was written in 1892, and discoveries since confirm it. Energy then is a state of matter, or rather, the result of a particular state or condition in which matter may be when any observed phase of energy appears.

In addition to possessing kinetic energy, the atom is capable of absorbing energy internally. This internal energy is associated with the configuration of the particles of which the atom is composed. Under ordinary conditions an atom is in what is known as a state of equilibrium, in which there is neither a giving off, nor an absorbing of energy. But, the internal energy of the atom can be altered. When the internal energy of the atom exceeds that of its normal state it is said to be excited. Excitations may be caused in several ways, e.g., the collision of an atom with rapidly moving positive or negative particles or the breaking of lines of force in an electromagnetic generator. Kinetic energy is released when excitation causes a particle to give up some or all of its kinetic energy to the atom during collisions. This is taking place in the universe all the time.

The electric motor and generator would never have been discovered if a dielectric (insulator) had not been discovered. If one discovers a dielectric valve for the energy of the universe, one has the answer to harnessing the energy of the universe! A limiting case of excitation is ionisation, wherein energy is absorbed by the atom sufficiently to allow a loosely bound electron to leave the atom, against the electrostatic forces which tend to hold it within the atom. An atom which has given up one or more electrons is said to be ionised. It is possible that ionisation, i.e., excitation, may take place in successive steps through absorption of quanta energy. The return of an ionised atom to a state of lower energy is associated with electromagnetic radiation. Also, from the process of ionisation, electrical energy may become associated with the vibrational forces of the universe coming into the earth as cosmic radiation. The higher the frequency, the greater the ionisation or excitation, a form of energy which is kinetic in nature. There are tremendous energies coming to the earth from outer space. These energies are only different manifestations of the energies we see in operation all around us. In most cases we are not even aware of their existence. They penetrate everything including our own bodies. Every one of us is alive by virtue

of these energies. Every part and particle of the universe is alive with them. The generators that now furnish our electric power do not create or originate any power or electricity; they merely direct, pump, the existing energy or electricity.

As in musical notes of high and low "C", the vibrational rates (frequencies) are different, but all "C" notes are essentially the same (harmonically related). This is the foundation upon which much of my investigation of vibratory phenomena is based.

It has been agreed that all forms of matter are vibrating at a particular rate or frequency. And, so it is with the various forms of energy - heat and light, magnetism and electricity. These are but forms of vibratory motion connected with and being generated from the same source, the universe. Matter vibrates at a particular rate, according to its character, and may be transmitted into other substance by lowering or raising its rate of frequency. If the frequency is raised high enough, the molecules will separate and the atoms become free. Raising the frequency still higher, the atoms resolve themselves into their original components. Matter then becomes a form of energy. Frequencies may be developed which will balance the force of gravity to a point of neutralisation. One can then go beyond the force of gravitation. Understanding the principles of vibration is truly understanding energy.

In gamma rays, we find potentials which are equivalent to as much as 1,000,000 volts, yet their wave lengths are not the shortest known. In octaves still higher there are rays which are known as "cosmic rays". Who can draw a definite line and say how much higher other octaves exist than those known as the cosmic rays? Our starting point from the discovery of these different waves was electrical conductivity of the air, and it has been found that this conductivity is just as strong by night as by day. Radiations emitted by the sun can scarcely be the sole cause of this energy. All space is saturated with vibration, energies, which are no doubt electrical in character. The relation of matter to energy and energy to matter then becomes the potential of the universe - one continuous series of oscillations.

Atoms maintain an equilibrium by oscillations, rotations, attractions and repulsions, but this does not interfere with a transformation of equilibrium, which, when the transformations of equilibrium are rapid enough, become energy, i.e., matter is turning into energy and energy into matter.

There can be no generation of electrical current and no kinetic energy if there is no disturbance of equilibrium, i.e., change of potential or change of energy levels. When one thinks of the oxygen and nitrogen molecules of the air all about us moving with the speed of bullets and striking us and everything else at this speed, one can form some idea of the agitation taking place here and in the universe.

The oscillations from outer space are emitting electromagnetic waves of many wavelengths and frequencies. The Moray device is so constructed that the frequency is very much lower on the secondary side than on the primary side, and almost complete resonance is established. I am convinced that the energies from the universe are active radiations produced by the evolution of matter into energy and energy into matter.

Dr Anderson's cloud chamber at the California Institute of Technology, in which the positron was discovered, has furnished much information about cosmic ray energies. He found that some positrons are born of cosmic rays smashing into matter. The cosmic ray energies deduced from the tracks left in the Anderson cloud chamber range from 100 volts to 3,000,000,000 volts. The Lemaitre-Vallarts theory, together with Dr Johnson's asymmetry measurements, give definite values for the energy of half of the cosmic radiation, and shows it continuously distributed between 5 billion and 50 billion volts.

The figure of 100 billion volts is a result of Dr W. Kolhorster's measurement of penetrating radiation in the depths of the Strassfurt salt mines. He found that the minimum energy of these rays had a penetration which was greater than ever before demonstrated. Dr Axel Corlin of Sweden's Lund Observatory found radiation that still had energy after passing through somewhat greater depths and, therefore, the voltage figures can be made even higher. Energies of 100 billion volts or more are indicated by the great bursts set off by cosmic ray collisions, called the stosse, which have been observed particularly in Germany. The Moray RE devices have worked equally well in deep mines, under water or high in the mountains and in an airplane.

It is about 100 years since science began to consider light, heat, magnetism, galvanism, and electricity as natural forces. In the early part of the 19th century school books termed these things "imponderable substances". The corpuscle theory of light was taught, the sun was supposed to provide an endless supply of those corpuscles. After the corpuscle theory faded, scientists turned to the wave theory, but even that was based on a crude concept of movement of the ultimate principles or atoms, of matter. The electron theory has superseded the earlier ones now, and while the electron theory explains the observed and theoretical "facts" better than the previous concepts did, could it be that, as the greater light of knowledge leads us on, the electron theory in turn will fall short of providing "absolute" knowledge? The Einstein Theory may stand in need of revision or amendment; or, in time, it may join the theories of corpuscles and waves on the back shelf.

A specific case, in which the electric field performs the double function of molecular excitation and the creation of intermolecular and atomic ions, is being given by the system used by the inventor. It is a system utilising the principles of the wire corona with a concentric cylinder at different pressures. The system is modified in conformity to the concept that chemical reactions must take place when the oppositely charged molecular ions from an appropriate activated catalyst are accelerated against one another in the wire corona. It consists of a cylinder made of a suitable catalyst from which positive ions are emitted. The reactants (gases) streaming through the chamber parallel to the length of the wire attain the polarity of the negative molecular ions by the high electric field close to the wire. As these negative molecular ions are accelerated at the right angles to the wire in the direction of the electric field toward the positively charged catalyst cylinder, they are met by an avalanche of onrushing atomic ions from the catalyst. A certain amount of reaction takes place in that instant, 10^{-8} seconds. However, some of the negative molecular ions outside the mean free path of the positive atomic ions are free to rush headlong toward the positive cylindrical field where they are neutralised, and instantly given a positive charge by the avalanche of out-rushing positive ions. These positive molecular ions are accelerated back into the field and collide against the negative molecular ions coming from the direction of the negative electrode corona. This melee continues until the reaction has come to a point where the individual participants are either all gone or the mixture is outside of the electric field: backrush oscillations.

The Moray apparatus combined with other equipment, consists of a combination of specially constructed tubes which we will refer to as valves, "pressure transmitters", interceptors and oscillators. The valves are not rectifiers in the sense that they operate as radio valves in changing Alternating Current or High Frequency oscillations into Direct Current. They have an actual valve action in stopping the "flow" of energy which may be thought of as oscillatory action similar to the waves of the sea, without rectification, from returning to the outer circuit, much as a retaining wall could stop the waves of the sea from returning. The other modalities and "tubes" of the device are equally unique in their performance. Although no new laws of energy are being advanced or claimed as having been discovered, the application in the method of utilisation of the energy throughout space is unique in that "generation" is accomplished by oscillatory utilisation rather than by the conventional prime mover. These detector tubes have a synchronised pull with the specially developed oscillators of high faradic capacity and provide a means through which oscillating energy may pass to specially constructed valve oscillators whose relation to the first stage valve is such as to permit oscillations to come in from but not return to the outer circuit with an automatic variable relation to the oscillations from the universe, and capable of setting up within their circuits initial oscillations which coincide with the oscillations of the universe.

Special provision is provided to stop RE tubes from becoming blocked in their dissipation of the charges created by the oscillations that continually accumulate based on the oscillatory capacity backrush effect common to capacitors and are herein applied in vacuum tubes. This action of these devices has the effect of enlarging and prolonging the time of charge and discharge of the capacitors and the capacity energy in the circuit to an appreciable interval in perfect harmony with the natural energy wave through the interceptor's valves and oscillators in the circuit which set up in the circuit electrical pulsations corresponding to the energy waves captured by the interceptor and again kept from returning to the second outer circuit by "multi-walled" valves. The final tubes act as energy pressure transmitters with a means to prevent "shunting" condensation by a special form of "getter". This stops condensation accumulating at the base of the tubes which would block their ionic action.

One must "split" the energy discharge band into lines of variation (call this what you will), lines of energy or lines of light beyond the "light rays". The oscillations, therefore, do not become simple oscillations but through the action of the universe set up an energy flow which might be referred to as the assertion of inertia. When inertia sets in, the action will continue because of the oscillations of the cosmos, otherwise one would have a complete dissipation of energy and no oscillations. The oscillation will vibrate during the same period of time regardless of the potential, but the rate of vibration of the device depends on the "capacity" of its modalities, i.e., condensers, etc.

Put together in pure energy resonance, certain energy responding apparatus which synchronise with the resonance of certain vibrations in the universe, and what do you have? Useable energy from the universe. This energy may come to the planets as oscillations similar to the oscillations and tides of the sea. The Radiant Energy tubes receive this energy in surges which may last only a few microseconds by the pressure and current in those surges are so strong that sufficient energy is delivered to the equipment in resonance to be useable in multiples of flashes and in a magnitude which competes with the light of day. Remember resonance and pressure can do a lot to amplify energy. Also remember that the vibrations going out from the sources in the universe must also return to their sources. Nothing is lost. There is only a lowering of potential like water flowing over a water wheel.

The Radiant Energy tubes present no new laws of physics. They simply expand the application of known laws, thereby obtaining results not at first thought possible. This is the history of science. Radiant Energy tubes possess greater ability to obtain "saturation" and thus charge the accompanying capacitors at a more steady rate.

When a certain voltage is reached, ionisation occurs in the gases of the discharged tube and causes the capacitors of the valve circuit to discharge into other capacitors of the valve circuit, to discharge into other capacitors of the oscillators and the other modalities of the circuit.

When ionisation in the preceding tubes is no longer possible because of the reduced voltage, the process starts all over again. The first valve passes vibrations of energy into an oscillatory circuit; ionisation sets in, a discharge occurs, and energy passes through another valve into other oscillators. The process is repeated from the first stage on to the second stage, on to the third and so on, much like a bucket brigade. That is why I asked years ago, "Cannot a steady flow of water be obtained from the waves of the sea or energy from the vibrations of the cosmos?"

When a vibration of any kind strikes a boundary between two media of different vibratory impedances at an angle of less than 90 degrees, a transformation of the vibratory rate may be changed into another vibratory rate. The Radiant Energy device therefore will continue to capture energy by resonance, or call it what you will, as long as the "keep alive" vibration of the cosmos continues to oscillate the various stages of the valves and oscillators in the circuit. Simple, is it not? Just a case of the trapping of energy which is everywhere present in the primary circuit and causing it to oscillate through the secondary circuits through a blocked circuit of no return.

Our experiments have proved that there is an energy which exists in the universe which, by proper development of equipment, can be made available for commercial use.

Such an energy transformer or converter has been built. It has been operated, at full load continuously with no expenditure of fuels of any type, without a mechanical prime mover, kept alive by the oscillations of the energies from the cosmos; an energy converter, or transformer, which would be capable of converting the high frequency, high level energy of the cosmic radiation into current of usable frequency and voltage.

Basically the theory of operation is as follows:

Oscillations are started in the first stage or circuit of the device by exciting it with an external energy source.

The circuit is "tuned" until the oscillations are sustained by harmonic coupling to the cosmic wave frequencies.

The reinforcing action of the harmonic coupling increases the amplitude of the oscillations until the peak pulses "spill" over into the next stage through a special detector or valve which prevents the return or feedback of energy from succeeding circuits.

These "pulses" drive this stage, which oscillates at a lower frequency and is again reinforced by harmonic coupling with the ever present cosmic waves.

The second stage drives a third stage, and additional stages are coupled until a suitable power level at a useable frequency and voltage is obtained by means of special transformers.

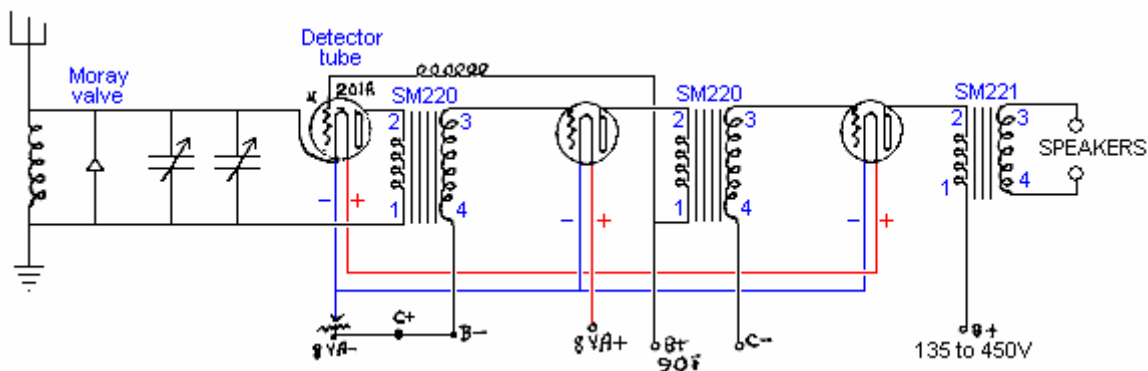

The specific information on Moray's system is very limited, especially since his patent application has been removed. The diagram above and the diagram below have been reproduced from what is alleged to be the notes from which the patent application was composed. These notes are not very clear both in wording and in the quality of reproduction, however, the diagrams shown here are an attempt to show clearly anything which is reasonably certain in those diagrams.

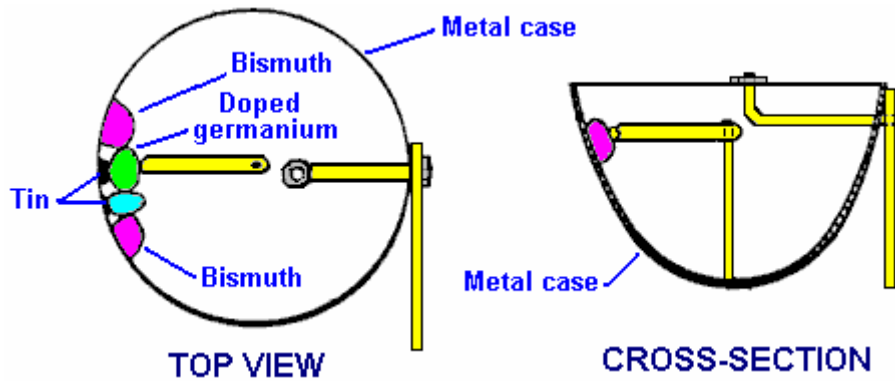

This is supposed to be the construction information on the Moray Valve which was capable of being set to either rectify a signal or to amplify a signal. The casing is a metal cup which also forms one of the contacts for the valve. Inside the cup there are four pellets attached to the side. The outer two pellets are made of bismuth and are fused directly on to the metal case. The two inner pellets are attached to the case with tin instead of solder. Judging from the drawing, it looks as if the metal arm contacting the pellets can only connect with the inner two pellets. The arm presses sharply against the pellets in the same way that the "cat's whisker" diodes of the time were touched with a silver wire to make a point contact and produce rectification.

If it is correct that the rotatable arm only contacts one of the two inner pellets, then the reason for those outer bismuth pellets must be as an indirect part of the valve. So, this section of the case is an arrangement of the metal of the case, tin, bismuth and five junctions between different materials, not counting the contact arm. One of the two inner pellets is made of purified germanium with the addition of very small amounts of a doping material. Iron Sulphide (FeS), Molybdenum Sulphide (MoS), Bismuth, Uranium and Silver have been mentioned as possible doping agents. Another material mentioned is Lead which has had its structure altered by the process described in Moray's patent US 2,460,707. The pellets are said to be produced under high pressure.

From this it can be seen that we do not have anything remotely like the full information on Moray's system. However, there are a number of important things which we can learn from this. Firstly, using just a good earthing connection and an aerial of just ninety feet (30 m) or so in length suspended only some eight feet off the ground, it is possible to draw significant current from the environment. The photograph shows 35 light bulbs being lit by Moray and that is a substantial amount of power. It is unlikely that we will be able to reproduce Moray's exact method of extracting power, but it is highly unlikely that his method is the only possible way of achieving efficient power extraction. So, if we experiment with the components and materials to hand today, it is distinctly possible that we could extract major amounts of power from a relatively small aerial wire positioned at quite a convenient height above the ground, and a good quality earth.

Moray's book "The Sea of Energy in which the Earth Floats" can be downloaded as a free 64-page eBook from <http://www.free-energy-info.tuks.nl/P26.pdf>

Hermann Plauson's Aerial Systems.

Hermann Plauson was granted US Patent 1,540,998 in June 1925. The patent is similar in style to Tesla's pick-up system and it illustrates the principle with a system which is very much like Paul Baumann's "Testatica" device hidden away in a Swiss religious commune. The patent is very detailed with 37 drawings showing different arrangements, and a more simply worded version is shown in full in the Appendix. In fact, the patent reads more like a tutorial rather than a patent.

A system of this type should most definitely be taken seriously: Hermann considers one of his systems with an output of 100 kilowatts as being a "small" system. However, it needs to be understood that each of Hermann's aerials, unlike those of Thomas Henry Moray, contributed less than one kilowatt each, and when Hermann speaks of a 100 kilowatt installation, he is referring to an array of more than one hundred separate aerials.

Hermann illustrates several different methods of energy capture and several methods of increasing the effectiveness of the captured energy. While an installation to capture a continuous supply of 100+ kilowatts is unrealistic for an individual, requiring many tall aerials, there is the distinct possibility of making a scaled-down version which is capable of providing serious levels of free power. Reading his patent through carefully is definitely to be recommended.

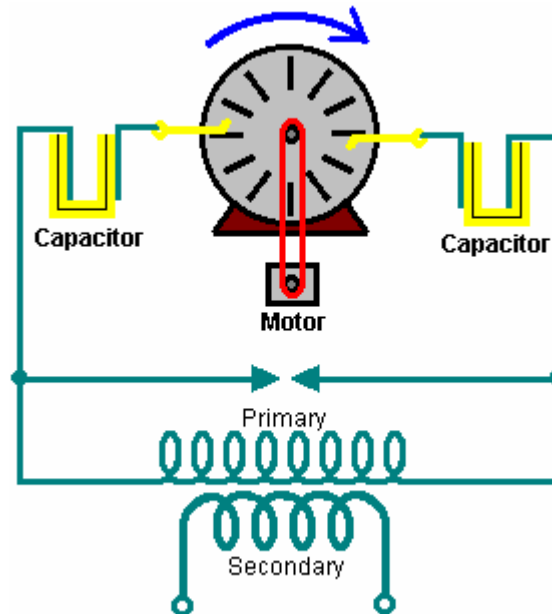

Herman starts by illustrating how working electricity can be taken from a Wimshurst machine. The Wimshurst output voltage is very high and the current capacity is very low and most people would dismiss it out of hand as being totally inadequate for any kind of practical work. However, Hermann boosts the power level by feeding the output into a step-down transformer which lowers the output voltage to a convenient level and raises the available current in proportion to the reduction in voltage. This is the same technique patented by Nikola Tesla. The apparatus which Herman illustrates is shown here:

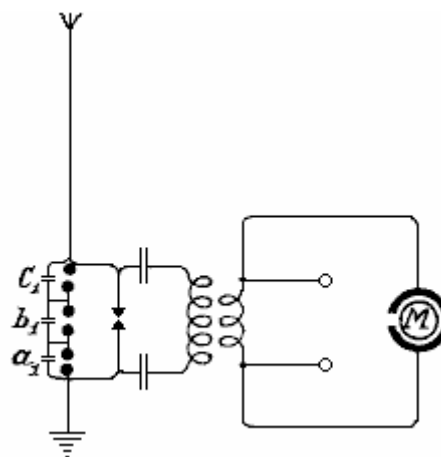

His patent says: "By suitably selecting the ratio between the number of turns in the primary and secondary windings, with regard to a correct application of the coefficients of resonance (capacitance, inductance and resistance) the high voltage of the primary circuit may be suitably converted into a low voltage high current output". It should be remembered that a spark produces a very sharply rising voltage pulse and that unbalances the local quantum energy field, as described earlier, producing very large energy flows as the local environment returns to its balanced steady-state. The spark, which is produced by relatively low power, is used as a trigger for vastly larger energy flows, which feed the step-down transformer, producing serious current at reasonable voltage, capable of doing useful work, without the requirement for any input power from the user.

You will notice how simple this circuit is. Three capacitors "a1", "b1" and "c1" in a chain, form a single high-voltage capacitor. The blobs shown connected across these capacitors are emergency discharge spark gaps put there to deal with unusual events like the aerial being hit by a lightning strike. This circuit is very much like the Wimshurst machine circuit which Hermann uses as an illustration of the principle of operation of these kinds of circuits. In this circuit, he shows a special motor marked "M" which is driven by the circuit and he also shows output terminals which can have other equipment connected across them.

When the oscillatory discharges in the primary circuit become weaker or cease entirely, the capacitors are charged again by the static electricity until the accumulated charge again breaks down across the spark gap. All this is repeated as long as electricity is produced by the static machine through the application of mechanical energy to it. Herman states that without the spark gap arrangement across the three capacitors connected

between the aerial and the earth, "it is impossible to collect and render available large quantities of electrical energy."

In addition to the use of spark gaps in parallel, a second measure of security is also necessary for taking the current from this circuit. This is the introduction of protective electromagnets or choking coils in the aerial circuit as shown by **S** in the diagram below. A single "electromagnet" having a core of the thinnest possible separate laminations is connected with the aerial. In the case of high voltages in the aerial network or at places where there are frequent thunderstorms, several such toroidal-wound coils may be connected in series.

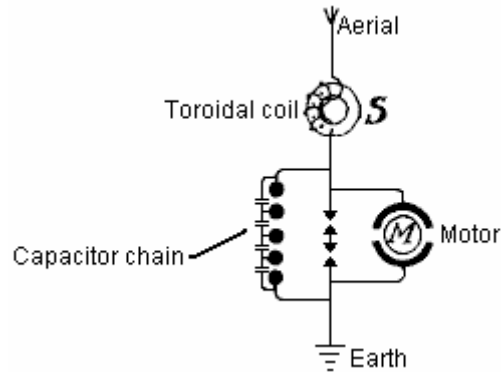

In the case of large units, several such magnets can be employed in parallel or in series parallel. The windings of these electromagnets may be simply connected in series with the aeriels. In this case, the windings should be made up from several thin parallel wires, which together, make up the necessary cross-sectional area of wire. The winding may be made of primary and secondary windings in the form of a transformer. The primary winding will then be connected in series with the aerial network, and the secondary winding more or less short-circuited through a regulating resistor or an induction coil. In the latter case it is possible to regulate, to a certain extent, the effect of these choking coils.

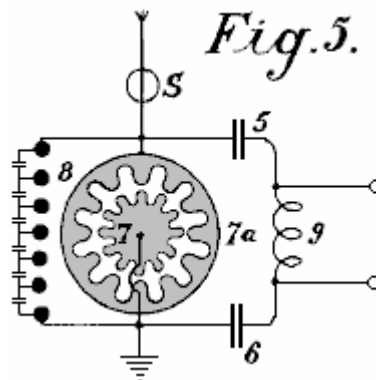

Fig.5 shows an arrangement for producing large currents which can be used directly, without motors, to provide heating and lighting. The main difference here is that the spark gap consists of a star-shaped disc **7** which can rotate on its own axis and is rotated by a motor opposite similarly fitted electrodes **7a**. When separate points of the stars face one another, discharges take place, thus forming an oscillation circuit with capacitors **5** and **6** and inductor **9**. A motor may also be connected directly to the ends of inductor **9**.

The patent continues by showing many ways to increase the power of the aerial system and many ways of applying the output to practical electrical devices. It contains 37 diagrams, a wealth of practical information, and a copy of it is in the Appendix.

Roy Meyer's Aerial Device.

Roy Meyers was granted UK Patent 1913,01098 in January 1914. The patent, which is included in the Appendix, shows an extremely simple device which produces an electrical output without any form of visible input whatsoever. This intriguing device was discovered when testing a very simple form, where two horseshoe magnets were interconnected with soft iron wire and two bars of zinc placed between the legs of the magnets. Roy found that he got an output of 8 volts using just two 4-inch magnets with 1-inch square legs and zinc bars of similar size. The physical orientation of the device is very important. The patent says that current is collected if the open ends of the magnets are pointing in a North - South direction and not if they are positioned in the East -

West direction. However, replication attempts seem to indicate the reverse of this with energy pick-up occurring when the alignment is East-West. Indications are that this is not an easy device to get operating correctly.

The first arrangement is shown in the following diagram:

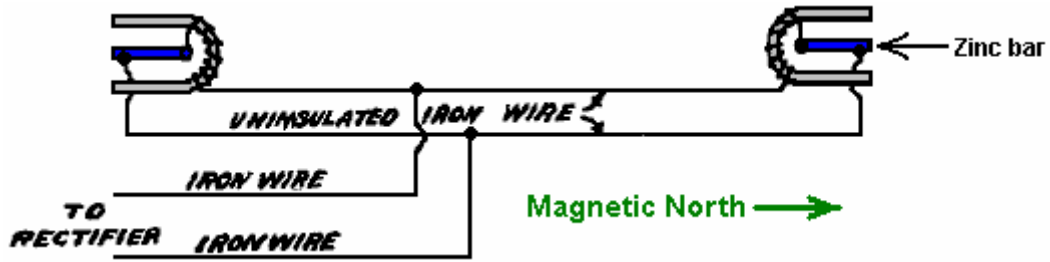

Roy developed his system further and found that while it works indoors, it does perform better if located outdoors and raised to a height of fifty or sixty feet. However, that is by no means essential, and the output power and voltage can be increased by increasing the number of collector units. Roy developed these to produce the style shown here:

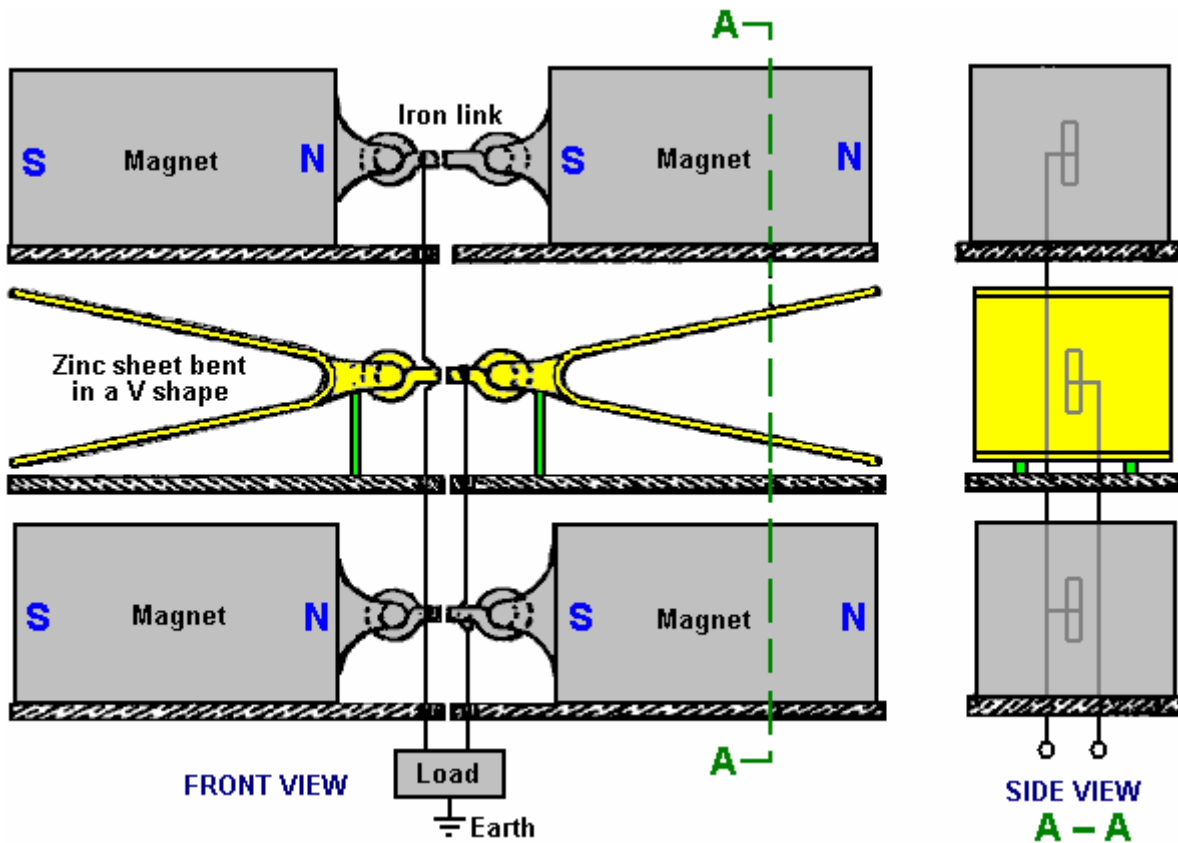

The zinc acts more effectively if installed as sheets bent into a V shape. The magnets and zinc sheets can be stacked vertically and/or horizontally and the greater the number used, the greater the electrical output. A good earth connection is recommended and presumably, the average cold water pipe of any house provides a more than adequate earth connection which is convenient to use, provided the pipework is made of metal.

The Aerial System of Raymond Phillips Senior.

Presents an interesting patent US 4,685,047 of 4th August 1987, entitled "Apparatus for Converting Radio Frequency Energy to Direct Current". While this patent speaks of radio-frequency energy, I can see no particular reason why that would be the only energy which could be picked up by this circuitry. The patent information is as follows:

Abstract:

This patent describes an apparatus and methods for converting radio frequency energy into direct current for generating electric power. It includes a dipolar antenna for receiving radio frequency energy and a circuit for converting the radio frequency energy to direct current. The circuit has a positive output line connected to one pole of the antenna and a negative output line connected to the other pole of the antenna. A positive transmitting diode is in the positive output line and a negative transmitting diode is in the negative output line. First and second bus lines and a pair of tuned circuits of opposite polarity couple the positive output line and negative line to the bus line with one of the bus lines being connected to ground. Each tuned circuit includes a first bridging line connecting the positive output line to the first and second ground lines and a second bridging line connecting the negative output line to the first and second ground lines. Each bridging line has in it, a diode connected with a polarity which is reversed with respect to the input diode. The bridging lines of each tuned circuit are connected to one another by an inductor and have capacitors placed between the diode and the bus lines. A Direct Current device is connected to the positive line of the circuit.

Background of the Invention:

This invention shows an apparatus for converting radio frequency energy to Direct Current of sufficient magnitude to power devices such as battery chargers and electric motors without the use of amplification.

There has long been interest in technology directed to transmitting electrical energy over a distance without using wires. Development of such a technology has enormous potential. This was first recognized by Nikola Tesla who in 1899 constructed a 200 foot Tesla coil rated at 300 kilowatts at 150 kilocycles. Tesla hoped to set up standing waves of electrical energy around the whole surface of the earth, so that receiving antennas set at optimum points could tap the power when needed. Tesla was able to light hundreds of lamps at a distance of about 40 kilometers with his device without using wires. The scheme has generally remained a scientific curiosity but has provided the initial groundwork for current developments wherein attempts are being made to transmit power using microwaves. However, power transmitted by microwaves is envisioned in the form of a beam of very high intensity which is focused from a microwave generator to a receiving antenna. This technology is envisioned as being used for many types of purposes, however, the focused microwave beam is not suitable for many applications because the beam must be directed toward a receiving antenna and cannot be transmitted through most objects, including living objects, without destroying those objects.

This invention relies on converting energy from standing waves which are emitted from radio frequency antennas in the RF range rather than the microwave range. Of particular interest are very low frequencies which are not used in communications and are available for transmitting power. Also of interest are the low frequency waves emitted by the earth due to pulsing of its magnetic field. These low frequency standing "earth" waves can be picked up by receivers tuned to them.

Summary of the Invention:

This invention shows an RF antenna for receiving radio waves. The RF antenna connected to a circuit configured to convert the RF signals to Direct Current. The radio frequency signals received by the antenna are transmitted to two leads, one being rectified to produce positive voltage and the other rectified to produce negative voltage. The positive voltage lead is connected directly to a positive output line and the negative voltage lead is connected directly to a negative output line. The positive output line is connected to a pair of bus lines through a first pair of capacitors, while the negative output line is connected to the pair of bus lines by a second pair of capacitors. Placed between the first bus line and the positive output line is a reverse diode of negative polarity, while placed between the negative output line and first bus line is a reverse diode of positive polarity. The positive and negative output lines are connected to one another through an inductor which is in parallel with the capacitors of the first and second pair connected between the second bus line and the positive and negative output lines.

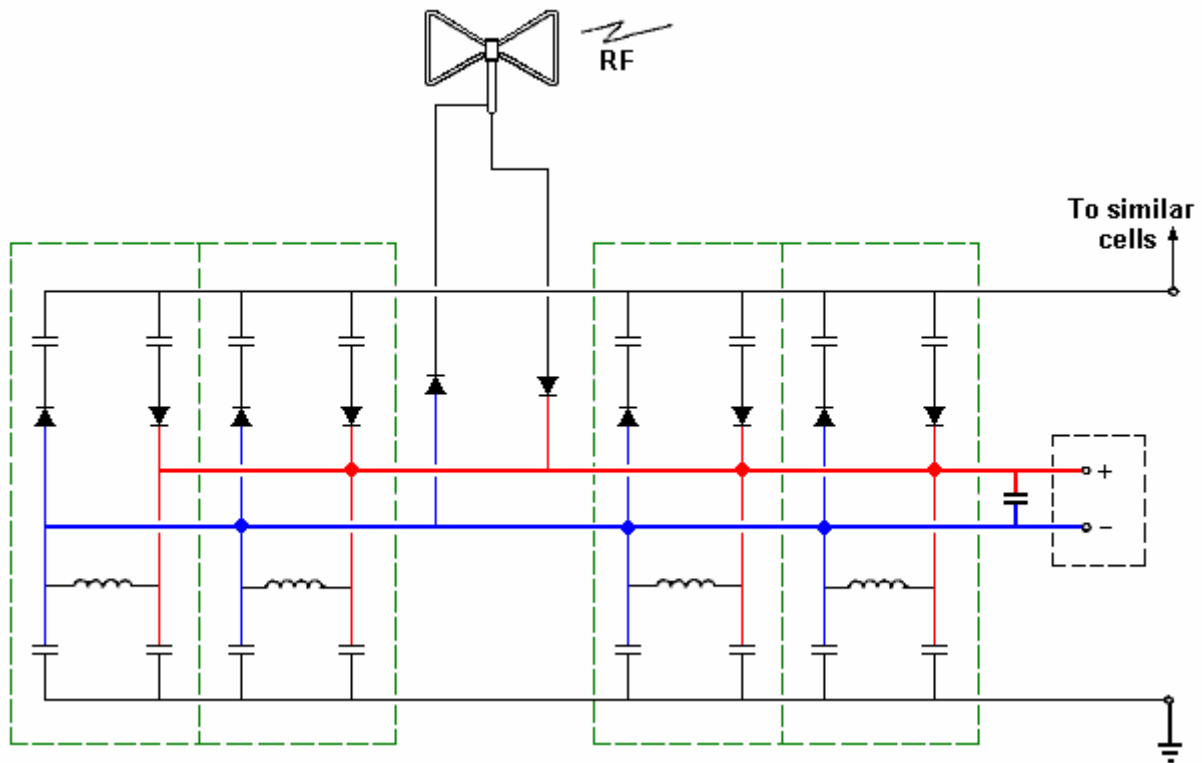

In one implementation of the invention this circuit is duplicated for each positive and negative output line. In another the circuit is coupled to additional identical circuits in order to increase the direct current output of the arrangement. In another implementation, the antenna used is a dipolar antenna of aluminium wire arranged in a "butterfly" configuration.

This invention uses these elements to generate direct current of sufficient power to perform tasks such as charging batteries, lighting lamps and powering direct current electric motors without the use of amplifiers.

Brief description of the drawing:

The reference characters used show the same or similar parts in each views, and what is shown is a diagram of a circuit, a driven device and a dipolar antenna which receives radio frequency waves which are then converted to DC current for powering the driven device.

Description of the preferred embodiment:

Referring now to the drawing below, there is shown a dipolar antenna, designated generally by the numeral **10**, which receives radio frequency waves from an RF transmitter.

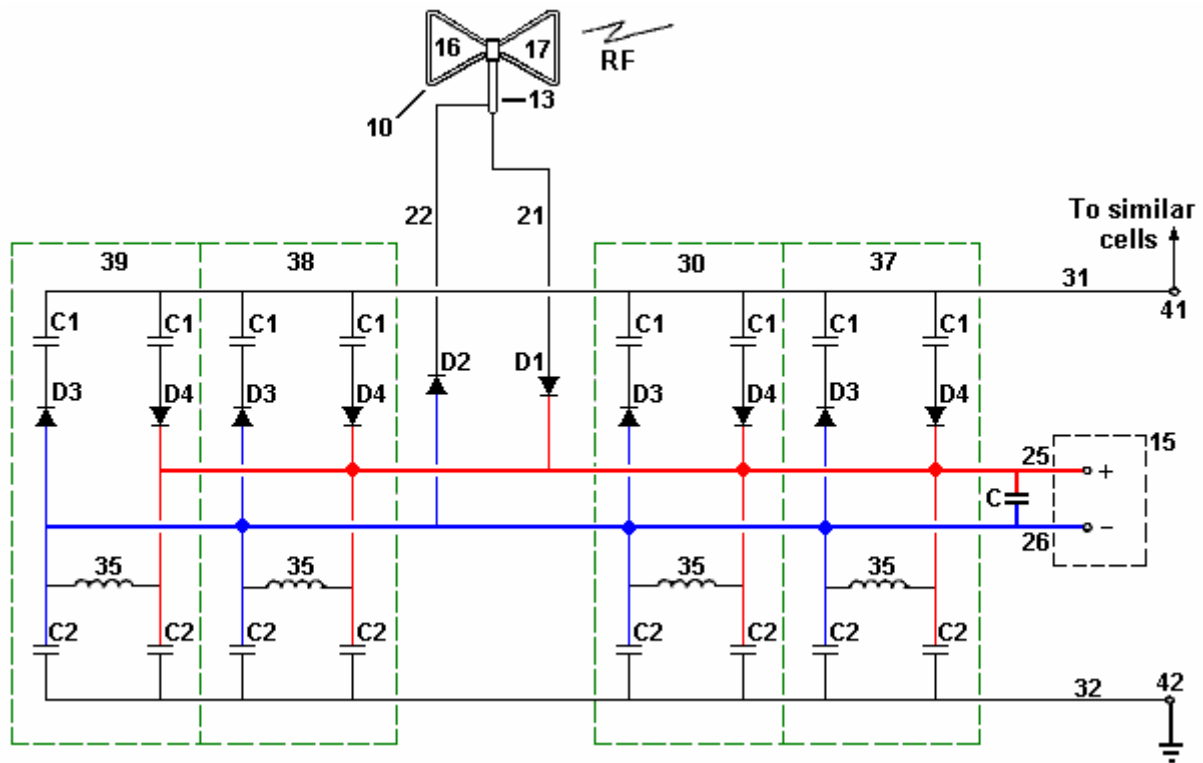

These waves are passed to the conversion circuit through a coaxial cable **13** and the DC output current of the circuit is used to power an output device **15**, which may be, for example, a battery charger, DC motor, or lighting device. The circuit has no other power inputs and so has no amplifiers for boosting the RF energy.

The source of frequencies which can be converted to Direct Current by the circuit shown may include sources of high frequency (HF), low frequency (LF), very low frequency (VLF) and extremely low frequency (ELF) radio waves as well as seismic vibration of the earth's magnetic fields.

Preferably, the dipolar antenna **10** is formed of two triangular loops of aluminium wire **16** and **17**, one of which is connected to the annular conductor **21** of the coaxial cable **13** and the other of which is connected to the centre conductor **22** of the coaxial cable. The size of the bipolar antenna **10** is dependent on the particular application to which it is put. In one embodiment of the invention, the antenna **10** is approximately **12** inches in width and **18** inches in length. Such an antenna is used to receive five watt energy, such as that generated by a walkie-talkie or citizen-band radio.

The outer conductor of the aerial is connected to positive lead **21** and the centre conductor of the coaxial cable is connected to the negative lead **22** of the circuit. A positive transmitting diode **D1** is placed between the lead **21** and the positive output line **25**. A negative transmitting diode **D2** is placed between the lead **22** and the negative output line **26**.

In order to provide a DC output of sufficient power, a number of inductance-capacitance RF tuned circuits **30**, each forming a positive cell, or a negative cell, are used to connect the positive output line **25** and negative output line **26** to the first and second bus lines **31** and **32**, respectively. Bus line **32** is connected to ground while bus line **31** can be connected to similar circuits. Inductor **35** serves as a radio frequency choke. As is seen of the drawing, the RF tuned circuit cell **30** is repeated a plurality of times. In the specific example shown, the circuit has separate cells **30**, **37**, **38** and **39**. The cells **30** and **38** are of opposite polarity and balance one another, while the cells **37** and **39** are of opposite polarity and also balance one another. In order for the system to function, a pair of opposite polarised cells must be used. The particular number of cells **30** and the value of the components in it, are determined by the configuration of the dipole antenna **10** and the power and frequency of the RF transmitter.

This radio frequency to direct current conversion circuit may itself be connected to a duplicate circuit via pin **41** so as to provide additional direct current output on lines similar to positive output line **25** and negative output line **26** the output lines may be connected together in order to boost the total output of the system.

An operative embodiment of the invention uses the following elements:

Diodes: D1, D2, D3 and D4 - Germanium Diodes, type **1N34A**,
 Inductors: **35-47 millihenry** R. F. Choke
 Capacitors: C1 and C2 - **0.47 Pico Farads** at 200 volts
 Coaxial Cable: 13 - 50 ohms
 Dipolar Antenna: aluminium wire triangular loops approximately 12 inches by 18 inches.

From the foregoing description, one skilled in the art can easily ascertain the essential characteristics of this invention, and without departing from the spirit and scope of it, can make various changes and modifications of the invention to adapt it to various uses and conditions.

The “Alexkor” Aerial System.

‘Alexkor’ who provided some of the charging circuits shown in chapter 6, also uses an aerial system for charging batteries in the 1.5V to 6V range. It is a simple system which uses an aerial of the type used by Thomas Henry Moray, that is, the bulk of the aerial is horizontal:

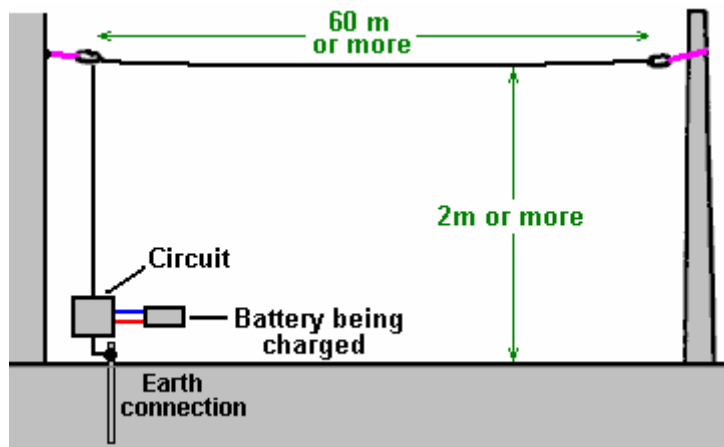

The suggestion is that the aerial is suspended between the eaves of a house and a nearby tree, but I don't know anybody who would be able to do that. The longer the aerial or the greater the number of aerials connected, the greater the charging power available. The aerial wire should be not less than 0.5 mm in diameter and it needs to be insulated from its supports – plastic cord can be used for that.

The circuit used is:

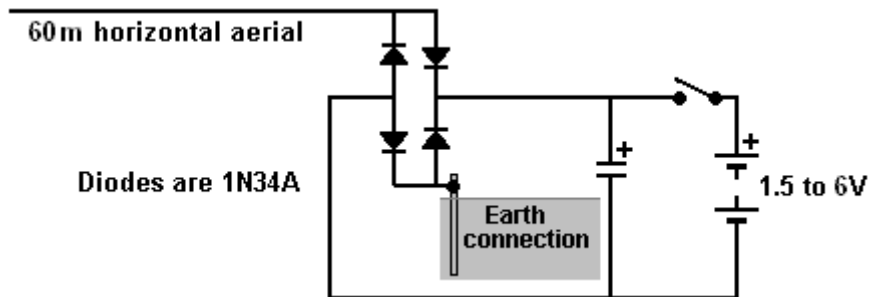

A more powerful version of the circuit is:

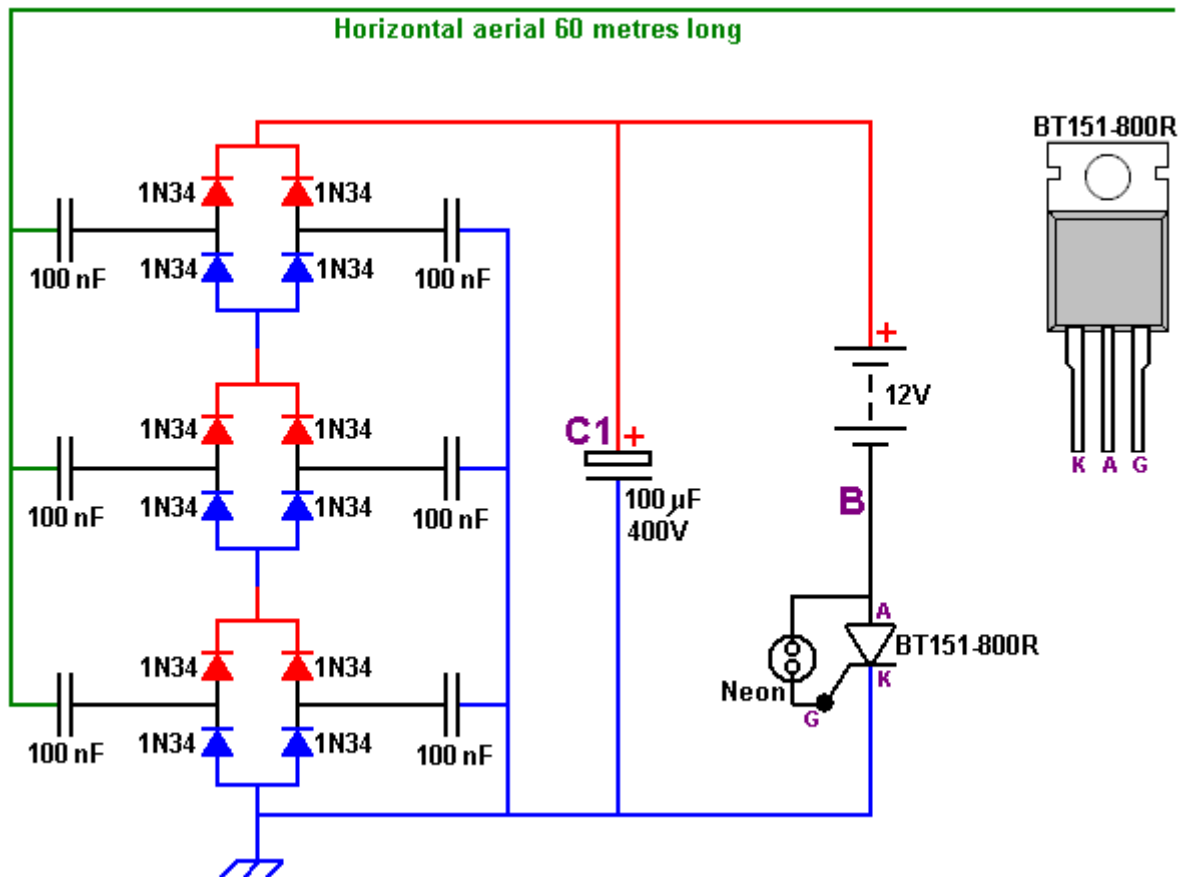

Here, there are three sets of diodes placed between the aerial and the earth. Let me stress again that the earth connection is a thick copper wire connected to a long rod or pipe driven into the ground or a large metal plate buried in dampened ground.

As the circuit operates, the three sets of diodes with their isolation capacitors, build up an increasing voltage on capacitor "C1". The voltage at point "B" will also increase and be about twelve volts less than the voltage on capacitor "C1". Eventually, that voltage will rise high enough to cause a discharge through the tiny neon tube and that current pulse flows through the Gate connection "G" of the thyristor, switching it on. Once switched on, the thyristor stays on until capacitor "C1" has been discharged, after which, the thyristor switches off and the process starts all over again. The amount of power in these pulses is considerable and the thyristor gets quite warm when the circuit is running. The BT151-800R thyristor can handle as much as 800 volts and pass 7.5 amps of current continuously.

An important point to note is that the power available from this circuit increases with additional aerials. With two aerials connected, the power is doubled and with three aerials the power is tripled. That is, each additional aerial provides as much power as the first aerial did and there does not appear to be any limit to the number of aerials which can be connected.

The TREC

There is a powerful aerial system which has been developed by Lawrence Rayburn of Canada. Initially, Lawrence intended to market kits to make it easy for people to replicate his aerial design which was providing him with ten kilowatts of power. However, Lawrence shelved that idea as he decided that the risk to users was just too high. He was also concerned that the aerial/earth combination might attract lightning strikes, causing considerable local damage. So, it is VERY important that you understand that this is a dangerous and potentially LETHAL aerial system which is quite capable of killing you if you are careless. If you are not already experienced in working with high-voltage/high-current devices, then this is NOT something for you to experiment with, and anyone who does fool around with this design does so wholly at his own risk as this material is presented "for

information purposes only” and there is **no** recommendation whatsoever that you should actually construct one of these aerial systems.

The technique used is quite different from the other aerial systems mentioned earlier in this chapter. Here, the objective is to create a tuned, resonant cavity reaching up to the ionosphere where there is a massive amount of excess energy supplied by the sun.

The tuning mechanism consists of two spirals of 3/4-inch (20 mm) copper pipe wound so that they cover a four foot (1220 mm) diameter area. These spirals are covered above and below with a sheet of Lexan plastic. The diameter of the copper pipe is important and smaller diameter should not be used even though it would be much easier to bend into shape. Actually, bending the large-diameter copper pipe is unlikely to be an easy task. Presumably, a pipe-bending machine would be used and a conical spiral produced and then the cone flattened to form the flat spiral. The spiral has even spaces between the turns, at all points along it's length.

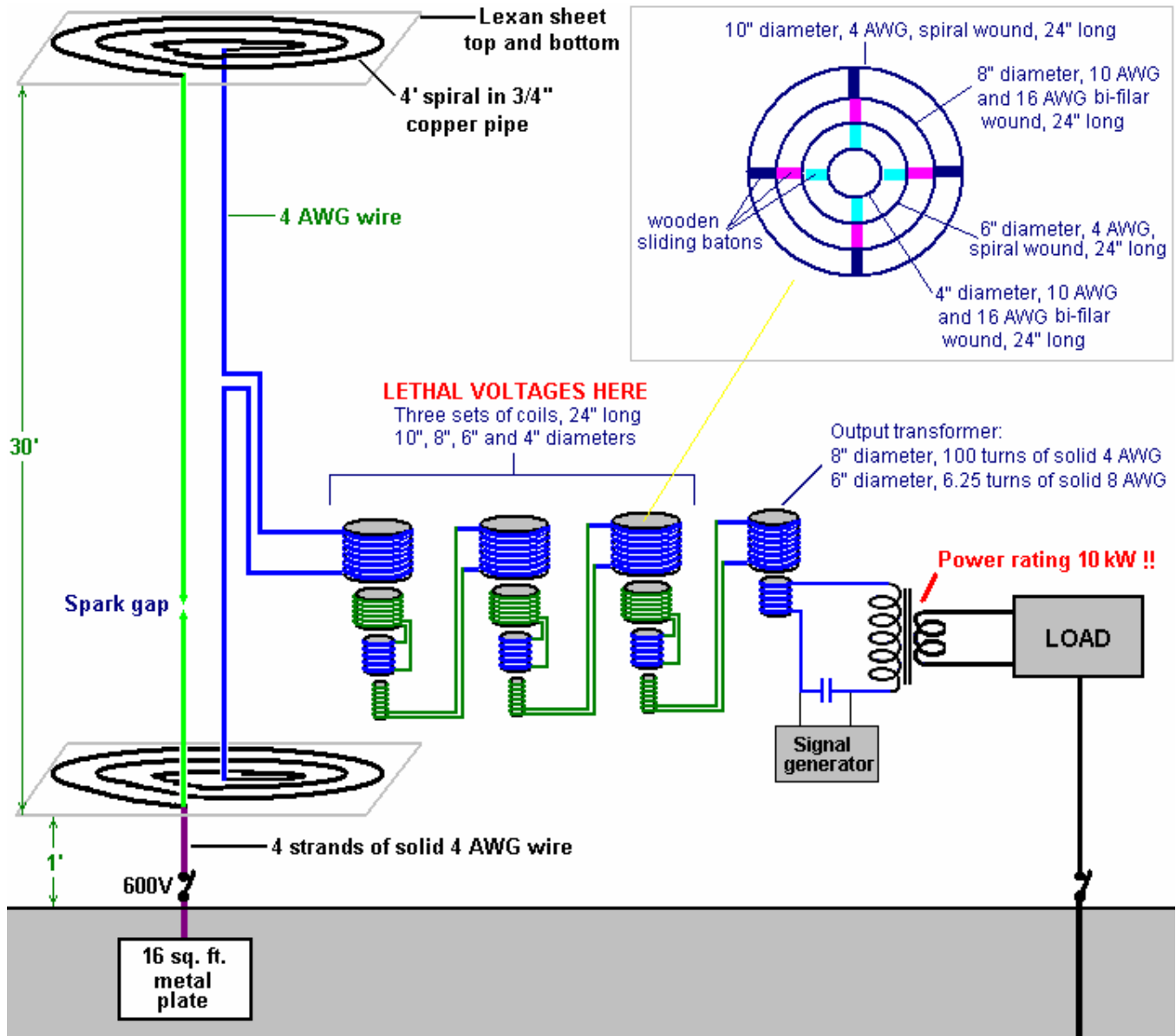

The two spirals are mounted, one vertically above the other with thirty feet (9145 mm) between them and the lower spiral being one foot (305 mm) above the ground. This means that this aerial system is only suited to people who can erect a structure of this height without inconveniencing neighbours or contravening local planning regulations.

The tuneable cavity is created by connecting the innermost ends of the two spirals together using 4 AWG wire which has a 5.19 mm diameter copper core. The outer end of the lower spiral is then connected to a large ground plate buried two feet (600 mm) below the surface of the ground, with four separate strands of the 4 AWG wire.

An adjustable spark gap is used. It can be positioned in the vertical wire between the two spirals, or in the middle of an extra 4 AWG wire run vertically between the outer ends of the two spirals. The power take-off is from the middle of the central vertical wire.

The cavity is tuned by sliding coils inside each other. This arrangement not only tunes the cavity but it also steps down the very high aerial voltage and raises the available current at the same time. This is where the danger comes in. The intermediate parts of this step-down tuning arrangement can have voltages of 600 volts at high current, and those voltages can easily kill you, which is why this is NOT a system for beginners and why Lawrence did not go ahead with selling kits for this aerial system.

The aerial output is fed into a final step-down transformer and a 50 Hz (cycles per second) or 60Hz signal from a signal generator is used to modulate the incoming power and allow it to be used with normal mains equipment which may need that frequency of AC. Resistive heaters and lights don't need AC or care about the frequency of any AC which they are fed.

The tuning of the system is very sharp and whatever is being used as the load affects the tuning. The wire used for the tuning array is insulated, single solid-core copper wire. 4 AWG has a core diameter of 5.19 mm, 8 AWG has a core diameter of 3.26 mm, 10 AWG has a core diameter of 2.59 mm and 16 AWG has a core diameter of 1.29 mm. Page 1 of the Appendix shows other characteristics for these wires. These heavy wires are an essential part of this design.

You will notice that two separate earth connections are needed for this aerial system. The second earth connection should be a long copper rod driven deep into the ground and some distance away from the buried plate earth. For the separation of two earth connections, ten metres (eleven yards) is generally considered to be a reasonable distance between them. The main earth is a 4-foot x 4-foot plate buried exactly under the lower spiral and the connection runs to the centre of that plate.

It is suggested that the spark-gap be constructed using copper-clad carbon welding rods, mounted in a nylon housing which allows the gap to be adjusted with a **nylon** screw. Remember that this is not a connection which you can disconnect from the power supply when making connections or adjustments. Also, on one occasion when a 500-watt light bulb was connected across the spark gap, it burned out instantly with a bright flash of light. This system is not a toy so thick rubber gloves and rubber footwear should be used.

The 4 AWG copper wires can be connected to the copper rods forming the spark electrodes, using copper pipe clamps. A tapered nylon rod could be used to adjust the spark gap screw while keeping well away from the copper. The spark gap should start at a one-inch (25 mm) gap and adjusted to no less than a half-inch gap. The spark gap and it's adjusting gear should be enclosed in a weather-proofing container and it has been suggested that it could be an advantage to fill that container with helium gas.

Please remember that coils, such as those in the tuning section of this system, have capacitance as well as inductance. The coil insulation is a dielectric and you standing on the ground form a good earth connection, so please don't imagine that you can't get a serious shock from handling an insulated coil carrying high-voltage high-frequency AC current, and in one implementation after modulation in the mixer at 60 hertz the pre-output transformer was measured at 3496 volts!

If you are not experienced in working with high-voltage circuitry, and still decide to try building and using this circuit, then please put your affairs in order and pre-pay your funeral expenses before you start building. (That statement is not intended to be humorous).

It is said that if the upper spiral is positioned at a height of just four feet (1200 mm) then the output is much lower and suited to charging a battery bank. As far as I am aware, this system has not been replicated and so there has been no practical feedback on building or using it.

The TREC appears to be not unlike the Patent Application US 2008/0191580 from Harold Deyo:

Harmonic Energy Exchange Device

Patent application US 2008/0191580

Inventor: Harold Stanley Deyo

14th August 2008

ABSTRACT

This invention converts inertial impulses into electric currents. Specifically, it converts impulses created by the impacts of high-energy particles from the Sun and other cosmic sources into the Earth's Magnetosphere and the varying D, E, F1 and F2 layers of its Ionosphere to controlled electric currents. This invention presents a new method of utilising energy from the Sun and other sources of high energy articles as a virtually, inexhaustible, alternative-energy source for the world.

BACKGROUND OF THE INVENTION

This invention relates to the conversion of impact energies created by the collision of high-speed cosmic particles and electromagnetic radiations with “Earth's Outer Layers” to produce inertial waves in the dielectric Troposphere which are subsequently converted into electricity by this invention.

The term “Earth's Outer Layers” refers to: Earth's Magnetosphere, Van Allen Belts, Ionosphere, Mesosphere, and Stratosphere as illustrated in Fig.2:

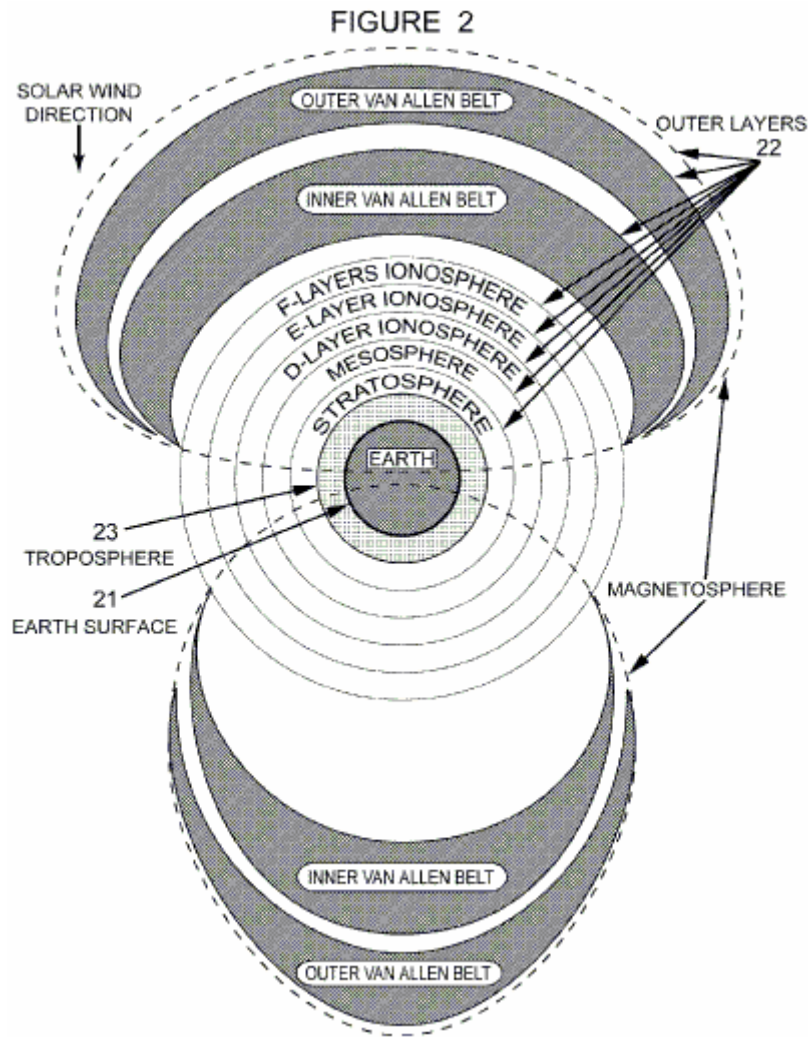

DESCRIPTION OF THE PRIOR ART

One day while reading an old scientific magazine I saw a small article on the research of Dr. John Trump of MIT (the basis for an electrostatic generator patented later by Onezime P. Breaux in U.S. Pat. No. 4,127,804). The article talked about a series of experiments which Dr. Trump had performed with a 2-plate, capacitor in a vacuum dielectric. Briefly, he discovered that by varying the distance between the two plates one could produce current flows in one direction or the other between either of the plates and ground.

The Solar Wind strikes “Earth's Outer Layers” constantly as do many other cosmic particles. At any given instant of time, the vector product of these impacts produces either a net pressure increase or decrease in the Troposphere. This creates random waves of pressure in the “Earth's Outer Layers” as one charged “plate” moves in relation to the oppositely-charged Earth's surface as the other “plate”. This variation of pressure in the “Earth's Outer Layers” is equivalent to moving an outer “plate” back and forth toward the Troposphere and the Earth's surface as the inner “plate” - thus giving rise to variations in voltage on both “plates”. In this case the Troposphere (see Fig.2) acts as the dielectric medium instead of the vacuum in the Trump experiments. Furthermore, the

Troposphere, itself, is also compressed and decompressed by these random waves of pressure on the "Earth's Outer Layers". Thus, I reasoned that if one could create a charged envelope or field of sufficient voltage within the Troposphere, one could convert these random pressure waves in the dielectric Troposphere into current flow on the Earth's surface.

As "Earth's Outer Layers" surround the planet, any impact waves propagate throughout all of them when they are present - even to the night-time side of the planet. Thus, I also reasoned that one could extract power from these impacts anywhere on Earth's surface or in it's atmosphere whether it be day or night. The pressure waves on the dark side of Earth would be less energetic than those occurring on the day-time side, because the night-time layers of the Ionosphere are compressed so much that the D-Layer of the Ionosphere disappears at night and the F1 and F2-Layers of the Ionosphere combine into one F-Layer. I calculated that the available energy from these impact waves would be significantly less by 30-45% depending upon one's location on the night side of the planet in respect to the terminator.

Many years ago, around 1900, Dr Nikola Tesla built and tested a device to extract energy from the Sun using an apparatus which forms part of my own invention (see U.S. Pat. Nos. 685,957 an 685,958 dated 5 Nov. 1901).

Subsequently, Dr. Thomas Henry Moray, another inventor and student of these Tesla patents made a device which apparently accessed the same source of energy but with a method different than my own. As Dr. Moray was never granted a patent for his device I cannot be certain that his work is considered prior art but I list it here as part of my due diligence. Apparently, he had trouble explaining to the patent reviewer, the source of energy which his device was converting, and thus, was not granted a patent for his impressive work. Dr. Moray's public disclosure of certain aspects of his invention are public knowledge through his published lectures and his book, "The Sea of Energy in Which the Earth Floats" - published in 1931.

Since the beginning of the 20th century, mankind has been looking for new sources of electric power to feed the ever-increasing energy demands of the human population. In the last half of the 19th century, coal, whale oil, human and animal labour, moving water, wind and wood were the main sources of energy. However, in the first quarter of the 20th century, mankind began to use more electricity produced by hydroelectric generators and generators producing electricity by combustion of hydrocarbon fuels. With increasing use of petrol engines and the increasing use of electrical appliances the demand for electricity accelerated the addition of heat and greenhouse gasses into the Earth's ecosystem.

In the last half of the 20th century, many forward-thinking individuals began looking for alternative energy sources to reduce the emissions of greenhouse gasses. All of the alternative energy systems investigated and/or developed in the last 56 years have had significant drawbacks to their usage as the main energy supply for the needs of humanity.

Some of those alternative energy systems were nowhere near as efficient as the existing systems. Some of the alternative energy systems still introduced extra heat into the environment like the existing fossil fuel and nuclear energy systems. And others produced even more greenhouse gasses than the existing energy systems. Some of the new systems used food resources to produce combustible fuels which, consequently, reduced the food resources of the planet. Among the leaders in the new energy sources was, and is, nuclear energy which produces extra heat, toxic wastes and materials which can be used in nuclear weapons. Hydroelectric energy sources do not add heat to the ecosystem but they are not an inexhaustible resource as they depend upon rainfall which is diminishing as global warming increases. Wind energy resources do not add heat to the ecosystem but they are not constant and require expensive conversion and storage equipment.

The ideal energy source for mankind will not add heat to the planet's ecosystem, will not produce by-product green house gasses; will not deplete our food and water resources; will not produce toxic wastes; however, it will be portable, self-replenishing and constantly available in real time anywhere on Earth and in useful quantities.

Our major source of natural energy on Earth is the Sun. Energy from the Sun enters the Earth's ecosphere by particle bombardment, radiated electromagnetic energy, gravitational variations and magnetic processes. Mankind has developed various methods of capturing energy from the Sun already. Silicon-based solar cells convert light in a narrow bandwidth into electron flows. These cells are, at most, only 50% efficient and only work when the Sun is shining on them at an optimum angle. Wind turbines only work when there is wind to power them and are, for the most part, not portable. Devices to convert wave action in the oceans only work when there are waves created by the wind and tidal effects caused by gravitational variations; and they are not portable enough to be used in common transportation devices.

I concluded therefore, that if mankind could find an inexpensive method of obtaining electricity from the Sun in some form which worked both day and night and which was already flowing into the Earth's ecosystem, we might be able to develop a clean and self-replenishing energy source which would add no extra heat to our ecosystem, would not alter our planetary albedo and might well be made in a portable form.

SUMMARY OF THE INVENTION

The Harmonic Energy Exchange Device (or "HEED") offers an interim solution to Earth's fossil fuel resources. It utilizes a previously untapped energy resource which exists throughout the known Universe. By the very nature of the invention, it only interrupts the flow of energy from the Sun and all the other cosmic sources of high-energy particles on their normal journey to the Earth by way of The Outer Layers.

The invention does not add energy to the normal thermodynamic equilibrium of the planet and its associated outer layers. The invention does not produce wastes - toxic or otherwise. It does not produce harmful gasses; and in some embodiments it could even assist in the rebuilding of our thinning ozone shield. Use of this invention will eventually remove mankind's dependence on fossil fuels and create new occupations. It will be cheap enough that homeowners will be able to install their own HEED and sell back energy to the grid until such time as every home has their own HEED and civilization has completely weaned itself from the use of fossil fuels and nuclear energy in its current form.

BRIEF DESCRIPTION OF DRAWINGS

FIGURE 1

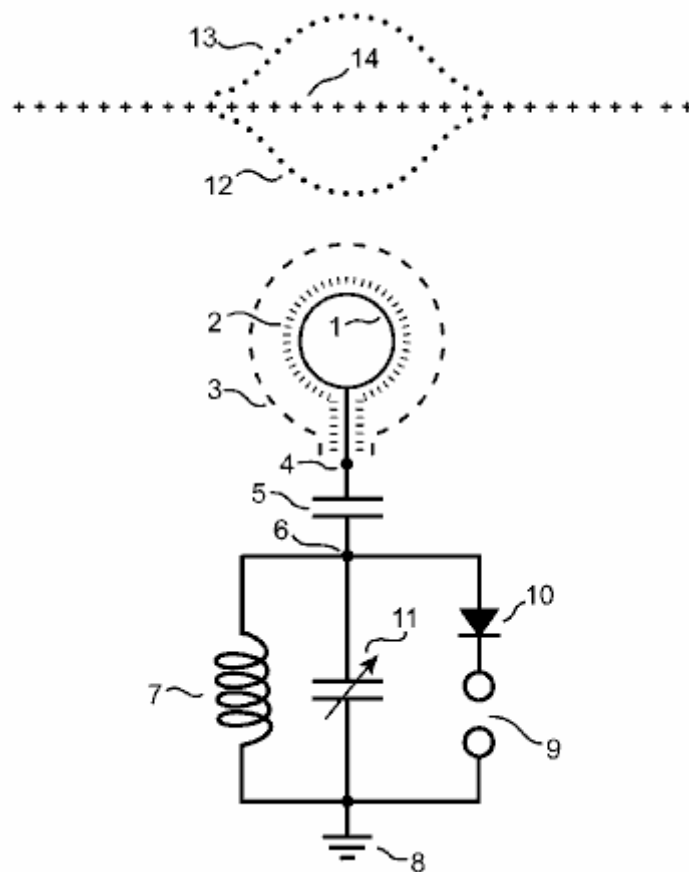

Fig.1: Is the preferred embodiment of the circuit diagram of my invention incorporating references to external stimuli which are used to activate the circuit. It represents a parallel tuned circuit to store the energy.

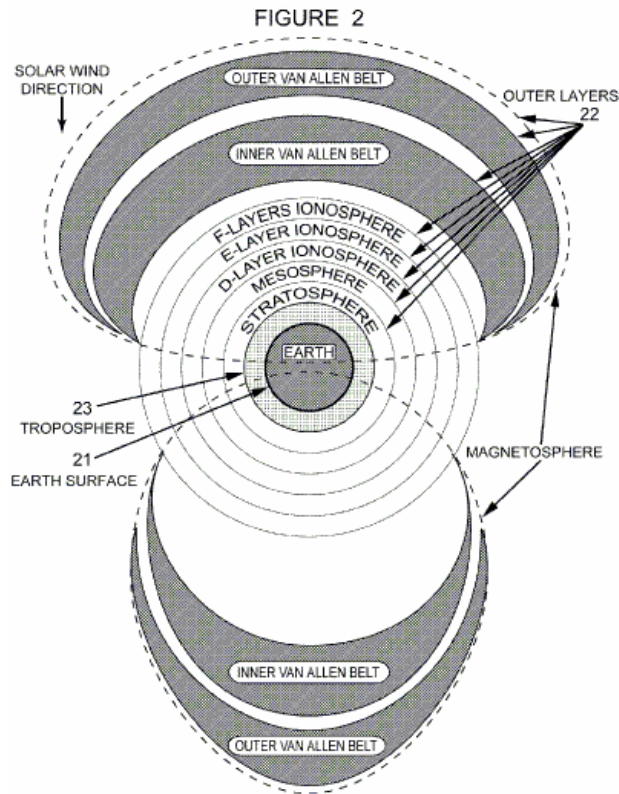

Fig.2: Is an illustration of the Earth and it immediate environment as a global capacitor where The Outer Layers form one plate and the Earth's surface form the other plate and both are separated by the Troposphere as a dielectric medium.

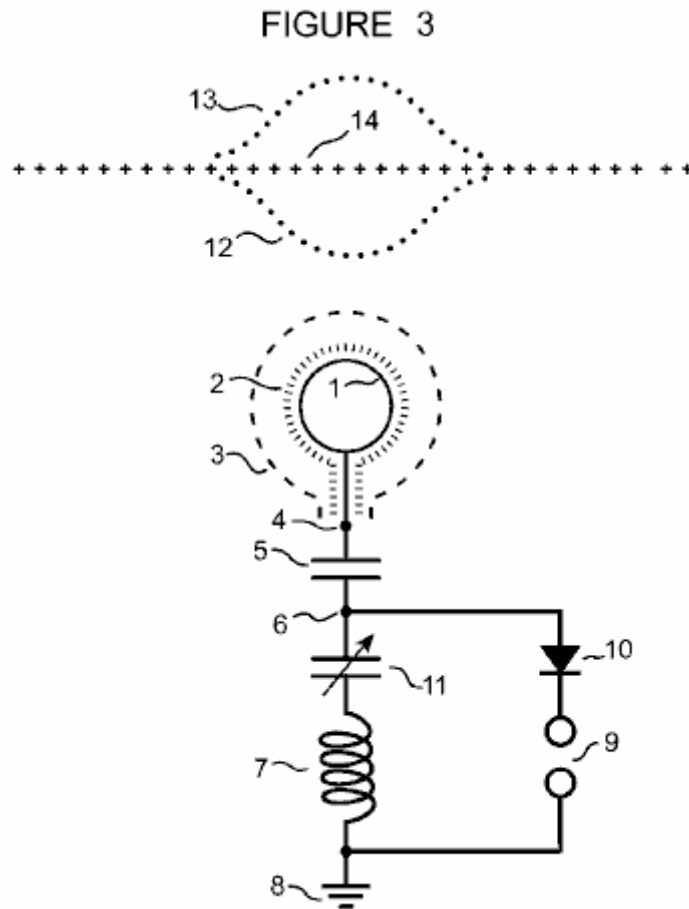
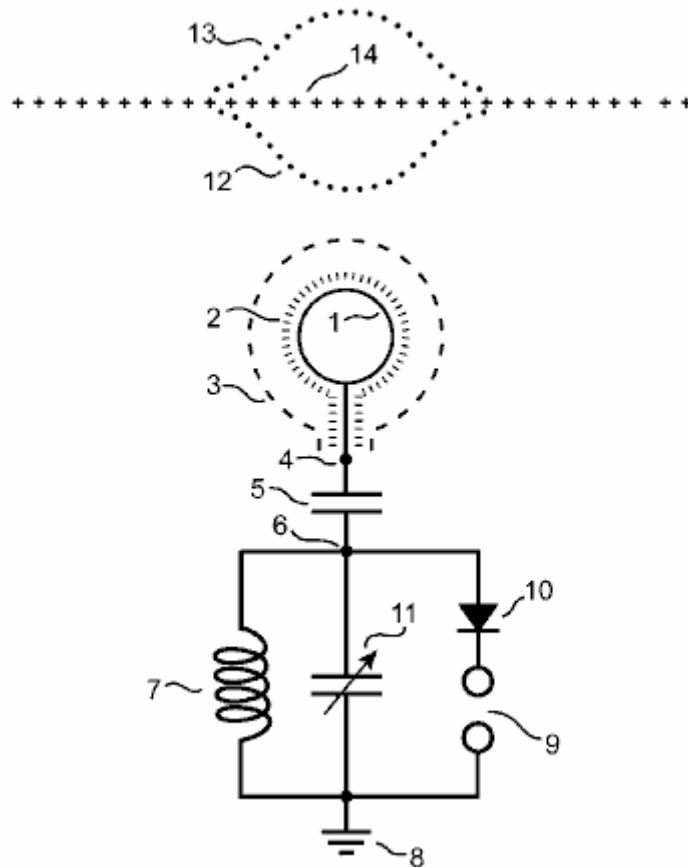

Fig.3: Is an alternative embodiment of the circuit diagram of my invention incorporating references to external stimuli which are used to activate the circuit. It represents the use of a series tuned circuit to store the energy.

DETAILED DESCRIPTION OF A PREFERRED EMBODIMENT OF THE INVENTION

Be it known that I, Harold Stanley Deyo, Jr, a citizen of both The United States of America and The Commonwealth of Australia, residing in the community of Pueblo West in Pueblo County, Colorado have invented a Harmonic Energy Exchange Device which converts dynamic pressures in the ambient media around Earth into controlled electric currents.

FIGURE 1



This invention as represented in **Fig.1** is unique in that it is designed to extract electricity from random pressure waves propagated in the Troposphere **14** by impacts of the solar wind and other cosmic particles with the Earth's "The Outer Layers" **22** of **Fig. 2**.

In **Fig.1**, the Troposphere **14** in its rest state is represented by the line of "+" marks **14**. The convergent or compression state **12** of the random waves in the Troposphere **14** is represented by the lower line of dots while the divergent or decompression state **13** of the random waves in the Troposphere **14** is represented by the upper line of dots. The preferred embodiment of my invention **Fig.1** is a method of coupling a parallel, resonant, electrical circuit to these random pressure waves to extract electricity from them.

As Dr John Trump's research and Onezime P. Breaux's U.S. Pat. No. 4,127,804 show, when one plate of a charged capacitor is moved closer to or farther from the other plate of that capacitor a voltage change appears on both plates of that capacitor. Furthermore, the electric field gradient between those plates changes as the plates are moved in this manner. Thus they have described a method of converting mechanical energy into electrical current by simply varying the plate spacing over time which can be expressed as ds/dt where "ds" is the change in spacing and "dt" is the change in time.

As illustrated in **Fig.2**, The Outer Layers can be viewed as one plate of a capacitor comprised of the Earth's surface itself as one plate **21** and Earth's outer layers as the other plate **22** where the Earth's Troposphere **23** serves as the dielectric medium separating the two plates. There is a charge between these plates which varies extremely rapidly but not with a constant period. At any given instant, the vector product of all the impacts by the cosmic particles with The Outer Layers **22** will create a pressure wave in The Outer Layers **22** which will manifest in the Troposphere **23**. Whatever that vector product is, it will alter the field gradient in the dielectric Troposphere **23**. That alteration will either increase or decrease the effective spacing between "plates" **22** and **23**.

In order to capture and convert the resulting voltage variations produced at or near the Earth's surface **21** of **Fig.2**, this invention creates its own, localised stress field **3** of **Fig.1** established in the Troposphere **23** of **Fig.2** with a charged, conductive surface **1** of **Fig.1** which is encased in high-voltage insulation **2** of **Fig.1** and extending into the Troposphere **23** of **Fig.2**.

In **Fig.1**, a series of high-voltage, starting pulses is applied across points **4** and **6** on opposite sides of a capacitor **5** to create the localised stress field **3**. As these high-voltage starting pulses are applied, the parallel resonant circuit formed by inductor coil **7** and variable capacitor **11** both referenced to ground **8** is stimulated into resonance within the bandwidth determined by the values of these circuit components. Tuning of this circuit is effected through variable capacitor **11**. The high voltage charge on conductive surface **1** of **Fig.1** is maintained by the parallel tuned circuit formed by inductor coil **7** and variable capacitor **11**.

Then as the random, pressure waves propagate throughout the Troposphere **23** of **Fig.2**, the localised stress field **3** of **Fig.1** is oscillated by the compression wave front **12** and the decompression wave front **13** (both in **Fig.1**) which creates voltage changes on capacitor **5**.

In **Fig.1**, the resulting voltages changes on capacitor **5** will add energy to the parallel resonant circuit formed by inductor coil **7** and variable capacitor **11** which acts as a tank circuit to store the energy which has been passed to it. As energy builds in the parallel circuit the voltage of the circuit rises until a spark discharge occurs across the gap **9** also referenced to ground **8**. The current will only discharge in one direction as determined by diode **10**. The circuit will work without diode **10** but a diode is used here as one method to keep from draining all the energy from the tank circuit when a discharge occurs.

This resonant circuit can be tuned to various bandwidths to maximise the efficiency of the conversion process depending upon the location of the device, the time of day, temperature variations, relative humidity and other variables in the ambient Troposphere **23** of **Fig.2** around the conductive surface **1** of **Fig.1**. A resistive load to extract power from the resonant circuit can be used instead of the spark gap **9** of **Fig.1**.

This preferred embodiment uses a parallel, tuned circuit to access a wide range of frequencies usually to be found in the range of 4.5 to 7 MHz. This range encompasses the major, naturally-occurring, resonant frequencies found in the ionosphere.

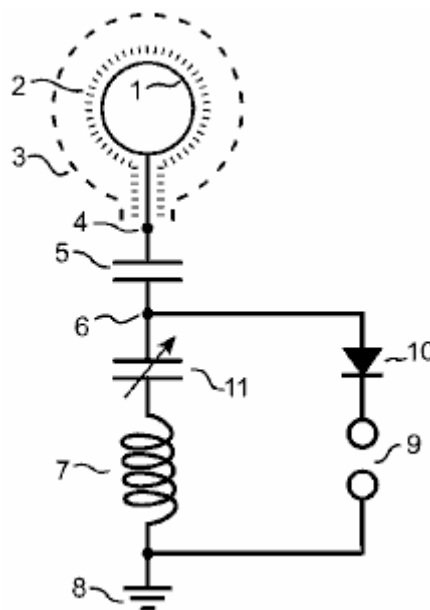

A second embodiment of this invention as shown in **Fig.3** replaces the parallel tuned circuit formed by inductor coil **7** and variable capacitor **11** in **Fig.1** placed in parallel to each other and referenced to ground **8**. This second embodiment forms a series-tuned circuit formed by inductor coil **7** and variable capacitor **11** in **Fig.3** placed in series to each other and referenced to ground **8**. It differs from the preferred embodiment only in the placement of variable capacitor **11** so that it is in series with coil **7**.

This embodiment limits the frequency range and, hence, the energy which the system will store when compared to the preferred embodiment. It produces higher voltages across the spark gap **9** than those produced in the preferred embodiment across the spark gap **9** of **Fig.1**.

What is said in this patent application adds some interesting factors to the TREC design of Lawrence Rayburn which pre-dates the Deyo patent by some years. His comment about replacing the spark gap with a resistive load suggests some alternative arrangements which might be tried out with the TREC system.

Also, somewhat along the same lines:

Translated from a Spanish-language original:

Many people think that it is not possible get power from the Earth magnetic field because that field intensity is too low and so the energy levels aren't high enough for any form of useful application. this is not the case. I have built many coils and I get many kilowatts for useful purposes from Earth's magnetic field and here I present the basic concept and some formulas fundamental to all of this.

The influence of the Earth's magnetic field should not be ignored. In times of strong sun activity, the Earth's magnetic field oscillates and in any long power transmission line there are voltage surges and over-voltages which can cause technical troubles, breakdowns and stoppages of the electrical sources. The Faraday law for that induction is given for the following:

$$V = 2 \times \pi \times f \times B \times A$$

Where:

- B** is the Earth's magnetic field,
- f** the frequency of the fluctuations, and
- A** the surface area across which the field flows.

For calculation purposes we can approximate the Earth's magnetic field as being 1 Gauss (or 10^{-4} Teslas)

If we consider an ordinary, long transmission line of about 10 Km in length with the power lines spaced 1 metre apart, then we have:

$$V = 6.28 \times 10^{-4} \times 10^4 \times f \text{ which equals } 6.28 \times f$$

If the fluctuations are $f = 10$ Hz, that produces an over-voltage of 63 V. If the fluctuations are 100 Hz then the over-voltage is 630 V, etc.....

So if the Earth's magnetic field is lower in intensity, the effect is considerable in a great surface and volume range.

For energy and power considerations, we can see that the Earth's magnetic field is lower than common permanent magnets, but the volume of space which it covers is very large. The energy in a magnetic field is not just the field intensity alone, but it depends also on the volume across which that field acts.

The energy stored in a magnetic field **B** across a space volume **V** is:

$$U = 1 / (2\mu_0) \times B^2 \times V \dots\dots\dots (1)$$

Where **μ_0** is the magnetic permittivity of the vacuum.

Common permanent magnets channel energy. If we can use them to get unlimited power like the Bearden's MEG, then the Earth's magnetic field across an air core coil can achieve the same result.

Now we can do a comparison between a permanent magnet and a coil oriented to the Earth's magnetic field to get the same energy levels.

Let's consider a powerful permanent magnet, as used in a MEG, of 5,000 gauss and dimensions of 50 mm x 20 mm x 10 mm. According to the equation (1) above, the energy stored in the permanent magnet will be:

$$U = 1 / (8 \times \pi \times 10^{-7}) \times (0.5)^2 \times (5 \times 10^{-2}) \times (2 \times 10^{-2}) \times (10^{-2}), \text{ so}$$

$$U = 0.995 \text{ Joules} \text{ - that is to say, roughly } 1 \text{ Joule of energy.}$$

Devices like the MEG with permanent magnets don't get too many kilowatts, the reason is because that magnetic energy is constant. If we close that magnetic field in a core or magnetic circuit and we pulse that field we get 1

joule of energy at any desired time rate because the permanent magnet stores that energy unlimited and so if we want a power output of 1 KW as the power **P** we calculate:

$$P = dU/dt$$

For $P = 1 \text{ KW}$, we need pulse 1 joule of energy for only 1 millisecond.

In the same way, if we can get power of the same levels from Earth's magnetic field, we must calculate the volume of the air core coil. By using the same equation, we see that

$$(0.5)^2 \times (5 \times 10^{-2}) \times (2 \times 10^{-2}) \times (10^{-2}) = (10^{-4})^2 \times V$$

V is the volume of the coil we need for get the same magnetic energy levels, and in this case, $V = 250 \text{ m}^3$

That is to say, a coil of 6.3 m diameter and 6.3 m length, placed parallel to the Earth's magnetic field, can store the same energy as that little 5,000 gauss permanent magnet which we considered for a MEG device.

But it is not necessary build a huge coil, we can use a smaller coil. The enclosed magnetic energy will be lower, but as $P = dU/dt$ we must raise the frequency of the pulses to obtain the same power level coming from a bigger coil. For example, an air core coil of 1 meter diameter and 1 meter length according to equation (1), stores an energy of:

$$U = 1 / (8 \times \pi \times 10^{-7}) \times (10^{-4})^2 \times \pi \times 1 / 4 \times 1 = 0.003 \text{ Joules}$$

If we pulse that energy level at 330 kHz, then we will get 1 kW, and at 660 kHz, 2 kW, etc., thus a higher frequency yields more power.

Then the question becomes, how can we pulse the constant magnetic field inside the coil? The answer is simple: by using an external source, we can cancel the Earth's magnetic field inside the coil. There must be power and energy amplification with respect to the external input source. To realise that power amplification, we must do the following:

Let the magnetic field variation inside the air coil be given by:

$$B(t) = B_o + B_f \times \sin(\omega \times t)$$

Where

- B_o** is the constant of Earth's magnetic field,
- B_f** is the magnetic field in the coil created by the external power source, and
- ω** is the angular frequency of the external source.

Replacing B(t) from equation (1) we get the energy variation with time, U(t), and then we can calculate the power as $P = dU/dt$ resulting in:

$$P(t) = B_f \times \omega \times V \times (B_o + B_f \times \sin(\omega \times t) \times \cos(\omega \times t)) / \mu_o \dots\dots (2)$$

Remember that V is the volume inside the coil.

We see here that the output power depends on B_o, the Earth's magnetic field, just as in the case of Bearden's MEG it depends on the magnetic field intensity of the permanent magnet in the circuit.

So we can now calculate a COP value with B_o and without B_o, or B_o = 0

Calculating the RMS power for both cases (not reproduced here because it corresponds to a case of basic differential calculus) and using the ratio, the result for the COP is:

$$COP = (1 + (2 \times B_o / B_f)^2)^{0.5}$$

We see then power amplification, and of course if B_o=0 and not a permanent magnetic field, the maximum COP is 1, input and output powers are equal. In the case of Bearden's MEG, the condition is B_o = B_f for not degaussing the permanent magnet and in that case we have a COP = square root of (5), which is a value between 2 and 3 which corresponds to the practical results for this classic calculation.

But for the Earth's magnetic field, we can get higher values because we can never cause a demagnetisation of the Earth's magnetic field.

How many turns on the coil, pulsing frequency, coil diameter, coil length, etc., do we need?

The input power to cancel the Earth's magnetic field inside the coil, or the condition $B_f = B_o$, we calculate using the RMS component of equation (2) above, setting $B_o = 0$, so we have:

$P = 0.05 \times f \times A \times L$, (where P is in watts).

A is the section of the coil in m^2 ,
f the frequency in Hertz,
L the coil former length in metres

To cancel the Earth's magnetic field inside the coil, the condition based on Ampere's law is:

$$N \times i / L = 100$$

Where **N** is the number of turns on the coil and
i is the current in amperes.

Finally, the induced voltage in the coil will be:

$$V = 2 \times \pi \times f \times N \times B_o \times A$$

So, with the following values, we have for example:

N = 1000 turns,
f = 100 kHz,
Coil diameter = 1 m,
Coil length **L** = 1 m,
i = 100 mA or 0.1 A,
B_o = Earth's magnetic field

This gives $V =$ approximately 4,000 Volts.

The input power for this example is about 4 kW, the output power for the COP factor will be a maximum of 12 kW. In closed-loop operation we provide the input 4 kW from the generated output and we get a self-powered generator producing 8 kW of output power. My practical results match these calculations.

How is a practical device built?

Using a large plastic pipe, we wind the primary input coil for use with the external source. For extracting the output power, we use another pipe placed inside the first pipe, and of approximately the same diameter and length with an adequate number of turns and wire size to step down the voltage, to, for example, 110 VAC. For the high voltage oscillator of the input source I use a resonant LC circuit taken from a ferrite power transformer.

It is very interesting to see this device work, and on days of geomagnetic storms, power levels go too high and I must use protective devices to prevent damage to the system and the loads connected to it.

Any questions to the following email: enertec2200@yahoo.es (which may not still be operational as this information is quite old).

Electrostatic Generators

Electrostatic generators are not at all unlike aerial systems in that a conversion to ordinary current is needed. The Swiss device designed by Paul Baumann (chapter 13) which has kilowatts of conventional electricity output power and which is self-powered demonstrates that very useful systems can utilise electrostatic charge. Paul's design is built around a Wimshurst machine which is self-revolving due to the sloping charge-collection strips which form an electrostatic motor as well as collecting the charge which is passed on to the remainder of the circuit.

Quite a number of electrostatic generators have been designed and used. They generally use a small, low-power motor to repeatedly alter the capacitance between a series of metal plates and so, create alternating current flow. Some of these designs are really clever in the way in which they operate. For example, the following patent from Charles Goldie has an input voltage source which is generated by the device itself and the voltage used can be adjusted by the user, while the device provides two separate DC outputs in series, which can be used as a single higher voltage if desired.

The Le May patent shown below has useful techniques which raise the output power to more than five times what it would have been without the use of those techniques. The general impression of electrostatic generators is that they are cumbersome and generally ineffective. That may be the case for some of them, but it is certainly not the case for all of them. For example, the electrostatic generator design of William Hyde, shown in chapter 11, has a COP=10 performance where the electrical output is ten times greater than the mechanical power needed to make it operate, and I'm told that the generator output can be 10 kilowatts which is a more than respectable output.

A particularly clever design comes from Onezime Breaux (US 4,127,804) where a high-voltage charge is generated briefly, and then that same charge is shuttled backwards and forwards through the output load, without that charge ever being 'used up' (to put it in layman's terms). As no system is ever 100% perfect, every ten minutes or so, the high-voltage charge is very briefly reinforced. A system of that type has to be capable of being a self-sustained generator. In a minimal prototype which was not perfectly constructed by any means, the power needed to spin the rotor was 0.8 watts, while the electrical output was 20 watts. This shows clearly, that electrostatic generators can be seriously useful, especially if built in the larger sizes.

The Charles Goldie Electrostatic Generator

US Patent 3,013,201

12th December 1961

Inventor: Charles H. Goldie

SELF-EXCITED VARIABLE CAPACITANCE ELECTROSTATIC GENERATOR

This invention relates to electrostatic generators wherein the charge transfer mechanism makes use of capacitive effects between charged bodies and electrodes upon which charge is to be induced, and in particular, to the self-excitation of such generators.

The invention may best be understood from the following detailed description, having reference to the accompanying drawings in which:

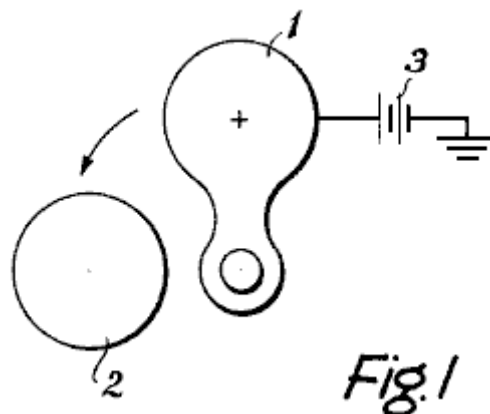

Fig.1 is a diagram illustrating one form of a variable-capacitance electrostatic generator;

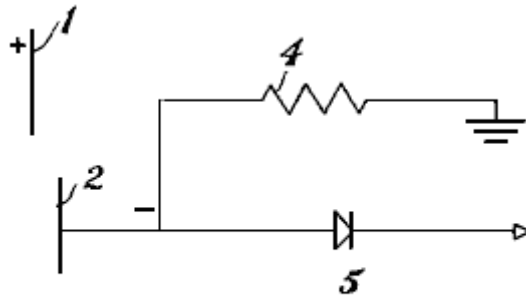

Fig. 2

Fig. 2 is another diagram further illustrating the arrangement of Fig. 1;

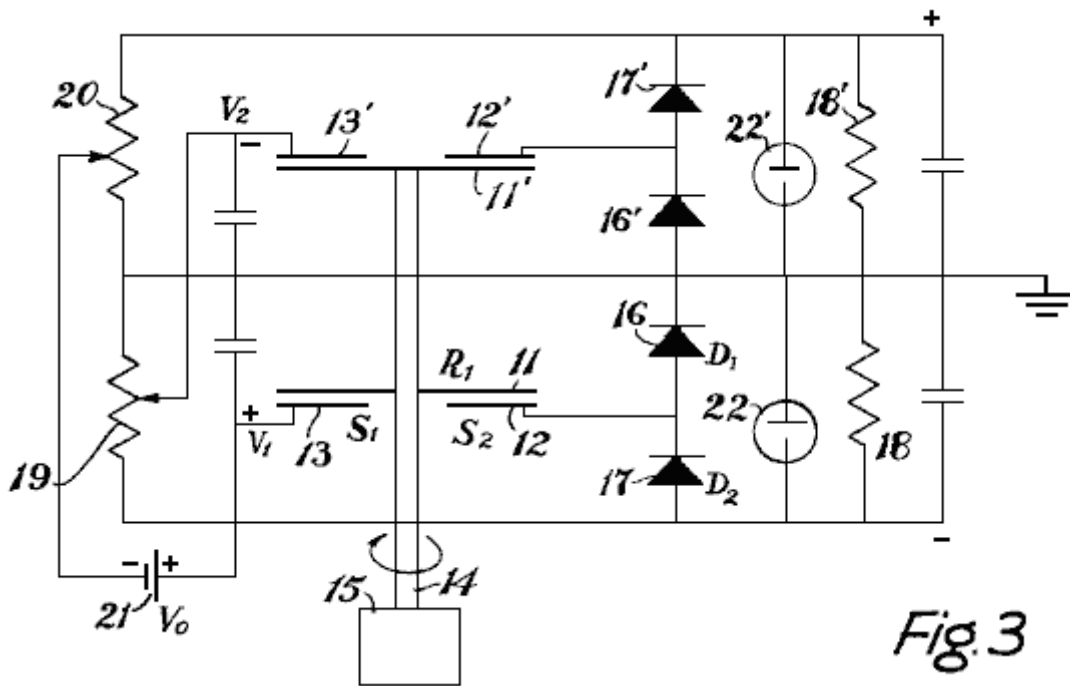

Fig. 3

Fig. 3 is a diagram illustrating a modification of the apparatus of Fig. 1 and embodying the invention; and

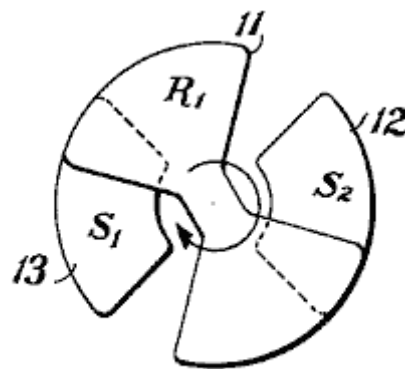

Fig. 4

Fig. 4 is a diagram illustrating a portion of the apparatus of Fig. 3.

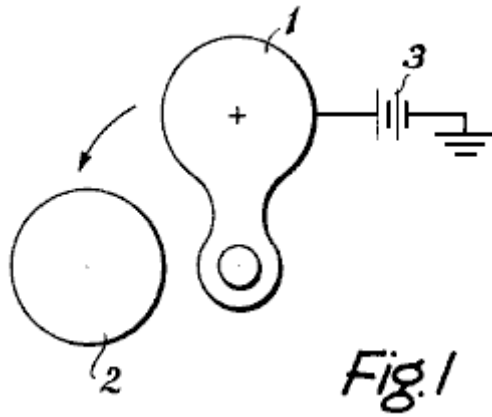

Fig. 1

Looking at the drawings in more detail, **Fig. 1** shows a rotor 1 and a stator 2. The rotor 1 has a positive charge on it. A power supply 3 maintains the charge on rotor 1.

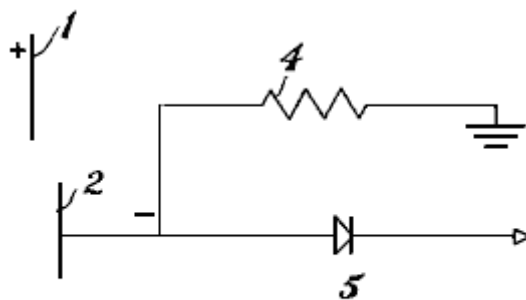

Fig. 2

In **Fig. 2** it can be seen that the stator 2 is connected to ground by a resistive path 4 which is connected in parallel with at least one rectifier 5 so that current can only flow in one direction between the stator 2 and ground.

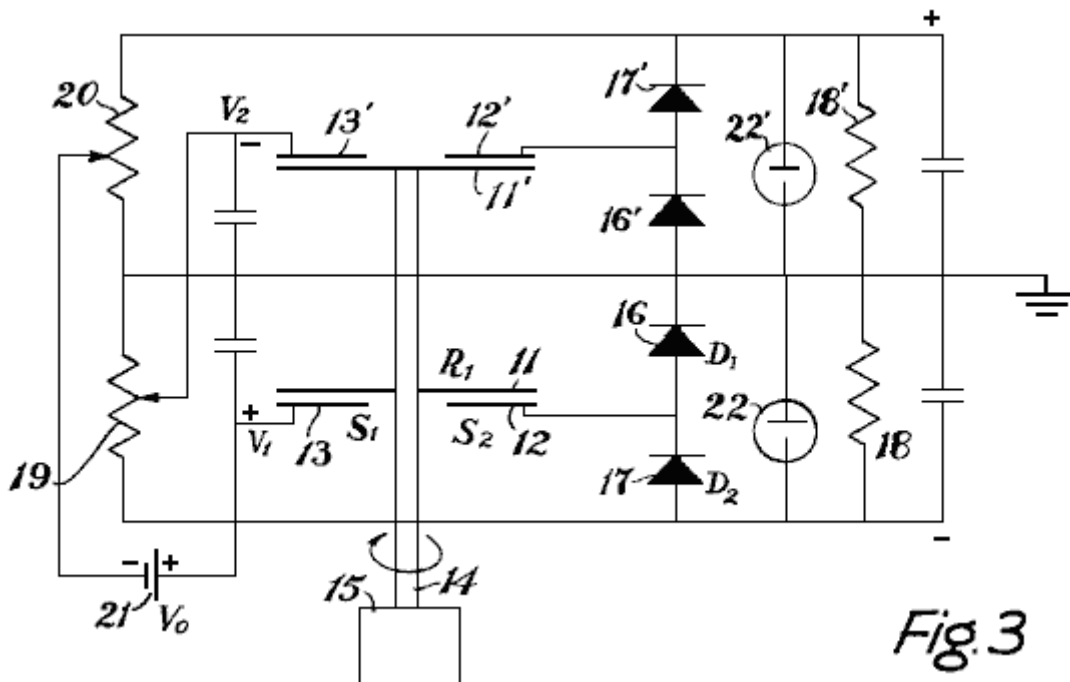

Fig. 3

In the device shown in **Fig. 3** and **Fig. 4**, the rotor serves as a capacitive link between a stationary charging electrode and a stator. A rotor 11 periodically passes close to a stator 12. However, instead of carrying its own charge as in the device shown in **Fig. 1** and **Fig. 2**, the necessary inducing charge on rotor 11 is itself induced on

rotor 11 by the charging electrode 13. So, when one end of rotor 11 is near the stator element 12, and the opposite end of rotor 11 is close to the charging electrode 13, a negative charge is induced on that portion of rotor 11 which is near the charging electrode 13 with the result that positive charge appears at the opposite end of rotor 11 since rotor 11 must itself be electrically neutral.

The invention will now be described with reference to the apparatus shown in Fig.3 and Fig.4, but it will be clear from the comments above, that the invention could equally well be used with a device of the type shown in Fig.1 and Fig.2. The principle advantage of the device shown in Fig.3 and Fig.4 is the fact that it eliminates the necessity of a brush on the rotor to supply it with charge, as the charge on the rotor is induced capacitively.

Referring back briefly to Fig.1 and Fig.2, it will be recalled that the invention is concerned with the construction of a self-excited generator with no external energy other than shaft power supplied. That is to say, the objective is a completely self-charging generator. Referring to Fig.1 and Fig.2, it will be seen that direct feedback of the output to the induction plate is ruled out by the polarity switch inherent in this type of machine. The difficulty is avoided by the two-section unit shown in Fig.3 and Fig.4. Here, a fraction of the output voltage of each section is fed to the induction plate of the other.

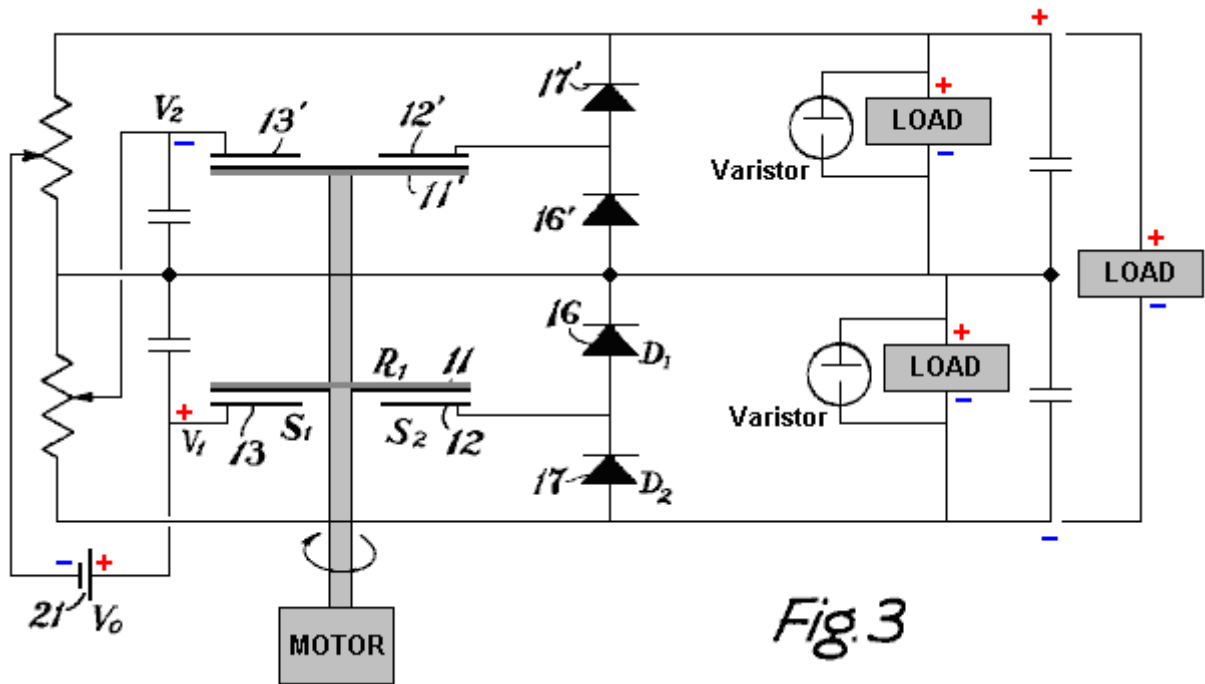

Fig.3

The action of the circuit is best understood by looking first at the lower section only. Rotor 11 is an electrically isolated, flat fan-like rotor mounted on an insulating shaft 14 which is driven by a suitable motor 15. As rotor 11 rotates, it periodically covers stator 2 and the charging electrode 13, both of which are insulated and sector-shaped. Charging electrode 13 is maintained at a positive DC voltage with respect to ground. As rotor 11 rotates into a position where it covers both the charging electrode 13 and the stator 12, the capacitance between the charging electrode 13 and stator 12 increases and negative charge is induced from the ground through diode 16 and on to stator 12. As rotor 11 rotates away from stator 12 and charging electrode 13, the capacitive coupling decreases and the voltage on stator 12 rises, negative with respect to ground. Diode 16 blocks any flow of negative charge from stator 12 and as the negative potential of stator 12 rises, current flows through a second diode 17 to the load 18. A fraction "V2" of this negative load voltage is applied to the charging electrode or induction plate 13' of the second or upper section by means of the variable resistor 19. The charging action of this second section is identical to that in the first section except for reversed polarities, and the output of the second section is correspondingly fed back to induction plate 13 of the first section via a second variable resistor 20. Variable resistors 19 and 20, control the output voltage and power by adjusting the feedback ratios.

The circuit is regenerative and so it is only necessary to supply a small reference voltage to start in the right direction. The use of stator and rotor materials with suitable contact potentials is one solution. Another solution is using a small battery 21 in one induction line. Suitable voltage-limiting devices 22 would be added either across induction plate 13, or across the load 18 to prevent excessive voltage build-up.

A number of features in this circuit are of interest. The usual slip rings and brushes are eliminated by the use of stator 12 and charging electrode 13 and an isolated rotor 11 rather than a single stator 2 and a rotor 1 maintained at constant induction potential as shown in Fig.1 and Fig.2.

In spite of the fact that the second section was added for the purpose of self-excitation, both output voltages are added together across the load **18, 18'**. The arrangement shown in **Fig.3** is merely for explanation of the self-excitation principle. The ground shown, for example, is not required and for higher voltages, the units may be cascaded with a common insulating drive shaft **14**. For a given total voltage output, the number of rotor/stator sets is the same for this self-charge generator as for a generator requiring auxiliary charging supplies.

Two poles are shown for simplicity. In an actual machine a greater number would be more practical. The system applies equally well to other geometrical arrangements, such as the concentric or segmented drum design mentioned in US Patent application 829,823.

The Le May Electrostatic Generator

US Patent 3,094,653

18 June 1963

Inventors: D. B. Le May et al.

ELECTROSTATIC GENERATOR

The present invention relates to an energy conversion machine of the type in which a variable capacitor is cyclically driven while being charged and discharged in synchronism with the cyclic variations in capacitance.

There are several different types of electrostatic machines which, for example, function to generate electrical energy from kinetic energy or kinetic energy from electrical energy. One broad classification for these machines is based on whether conductive or non-conductive apparatus is used to transport electrical charge within the system. The present invention relates to the class of machines in which electrical charge is transported through conductive apparatus. More specifically, the present invention relates to electrostatic systems in which a form of variable capacitor is mechanically driven to provide a cyclically-varying capacitance which is charged during intervals of high capacitance and discharged at intervals of low capacitance, to provide electrical energy.

In general, previously-proposed variable-capacitor electrostatic generators (sometimes called electrostatic induction generators) have been capable of very high efficiencies and could be embodied in relatively light apparatus. These considerations result primarily from the fact that electrostatic fields may be sustained in air, vacuum, or other very light medium, while electromagnetic fields necessitate the use of heavy ferrous material. Further, the electrostatic fields are caused by charges carried on surfaces, rather than by currents in conductors, so that the relatively heavy copper requirements of electromagnetic machines may be avoided. It has been found that electrostatic machines operating in a vacuum, do not have the iron loss, copper loss or windage loss of electromagnetic machines, thereby achieving their extremely high efficiency.

However, other considerations have prevented these machines from coming into widespread use. Specifically, prior electrostatic machines of this class have normally been of large size relative to their power capacity. Furthermore, practical use of prior machines has normally required extremely high voltage operation. Both of these drawbacks result from the nature of the electrostatic field, it's requirement of high potential gradients for field strengths comparable to electromagnetic fields, and the limitations on potential gradients imposed by the breakdown of the dielectric medium. Therefore, considerable insulation and safety equipment has been required in prior electrostatic systems, and operation at moderate voltages has not been practical. Still further, certain forms of electrostatic induction generators have necessitated rather complex switching systems to charge and discharge the capacitors; these systems have not been commercially feasible.

In general, the present invention comprises an efficient electrostatic induction system capable of economical operation which may be embodied in a unit that is small in size relative to power capability. The system includes two sets of rod-like members, one set of which is revolved relative to the other, so that certain of the relatively-moveable rods provide a variable capacitance. The other rods in the structure are then used to shape the electrostatic field in a manner which produces a greater difference between the minimum and maximum capacitance of the apparatus, resulting in increased power conversion capability for the size of the unit. The variable capacitance structure is connected to an electrical system which charges and discharges the capacitance in a cyclically-varying manner. Reactive elements are then coupled to the system to cause voltage phase shifts in the system relative to the variable capacitance, to increase the charge applied to, and taken from, the capacitance structure during the operating cycle, thereby further increasing the power-conversion capabilities of the system.

Another object of the present invention is to provide an improved electrostatic induction system.

Another object of the present invention is to provide an electrostatic induction generator or motor which has a higher power conversion capability relative to it's physical size.

Still another object of the present invention is to provide an electrostatic energy conversion system which may be embodied economically in a relatively small size apparatus.

A further object of the present invention is to provide an electrostatic induction motor or generator in which energy is more effectively converted to another form by improving the shape of the electrostatic fields in the system.

Still a further object of the present invention is to provide an electrostatic induction generator or motor in which energy is effectively transformed to another form by the provision of reactive elements to tune the capacitive elements that are inherent in the system.

One further object of the present invention is to provide an improved system for efficiently converting energy from one form to another, wherein an electrostatic field is used to inter-couple the different forms of energy.

These, and other objects of the present invention will become apparent from a consideration of the following, taken in conjunction with the drawings, wherein:

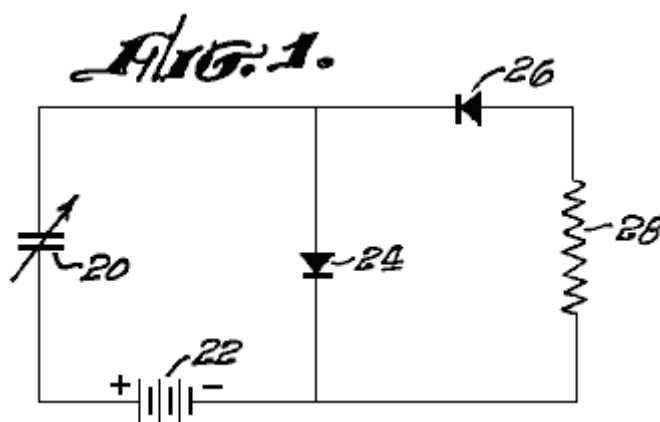

Fig.1 is a schematic diagram illustrating the basic operation of a preliminary system to which the present invention may be applied;

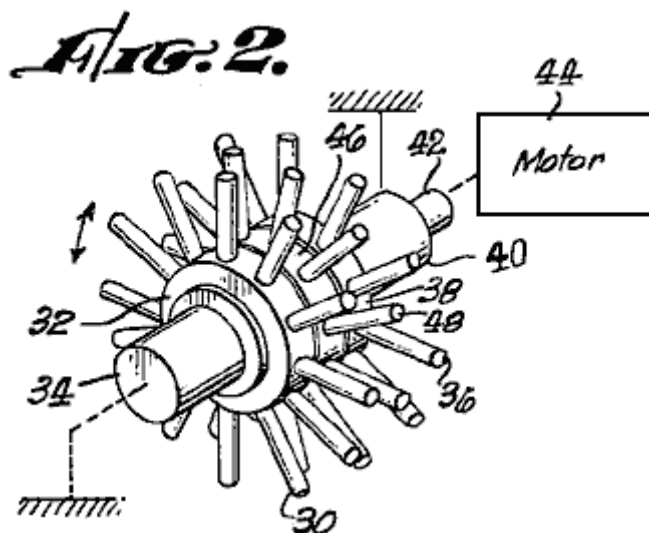

Fig.2 is a perspective and diagrammatic representation of one form of variable capacitor which may be incorporated in an apparatus of the present invention;

FIG. 3.

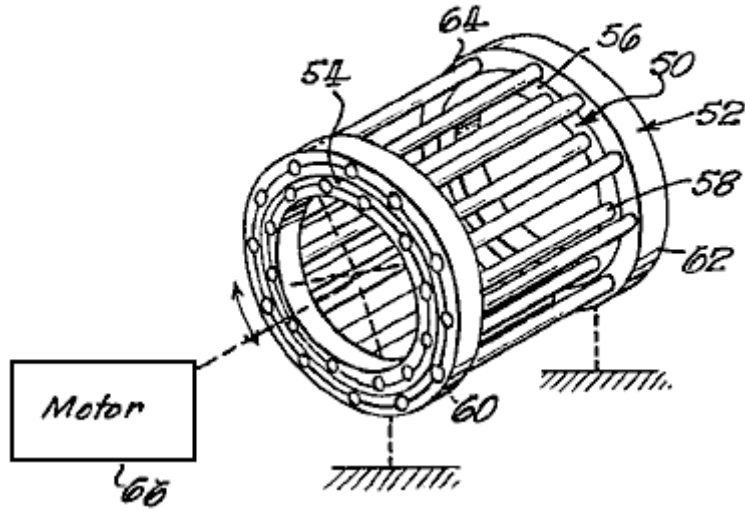

Fig.3 is a perspective view of another form of variable capacitor which may be incorporated in an apparatus of the present invention;

FIG. 4a.

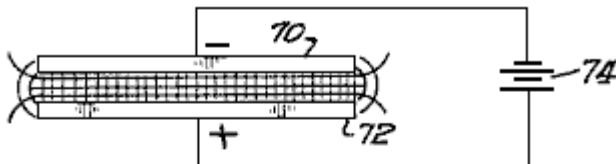

FIG. 4b.

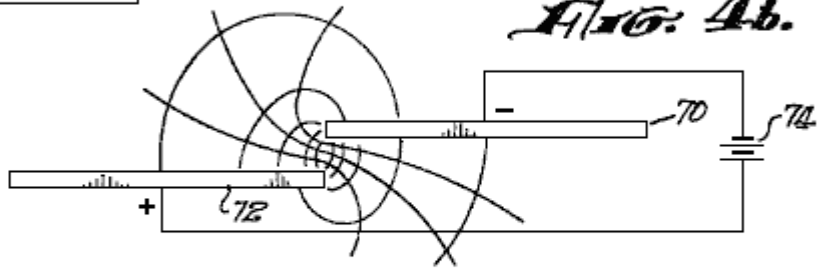

FIG. 4c.

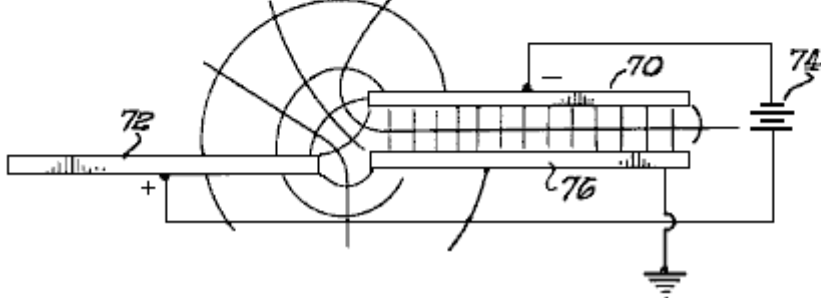

Fig.4a, 4b and 4c are diagrammatic representations illustrating an aspect of the operation of a system incorporating the present invention;

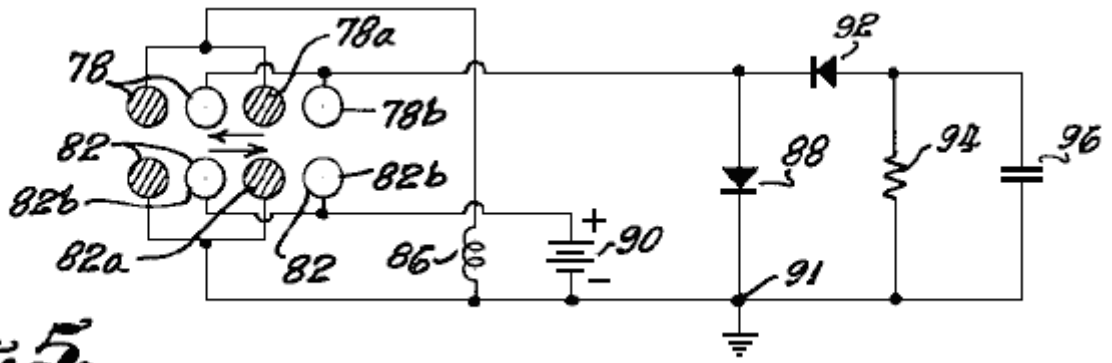

FIG. 5.

Fig.5 is a circuit diagram incorporating one form of the present invention;

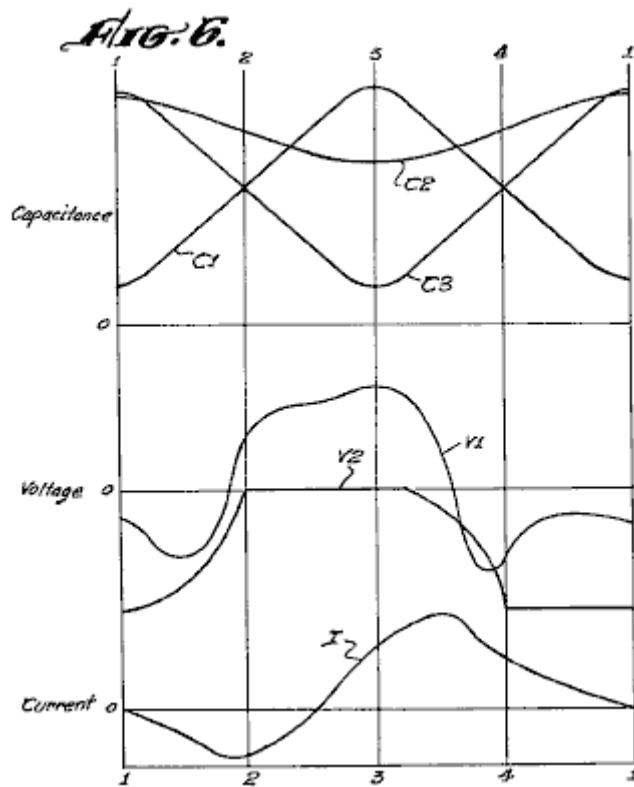

Fig.6 is a set of graphs illustrating the operation of the system shown in Fig.5;

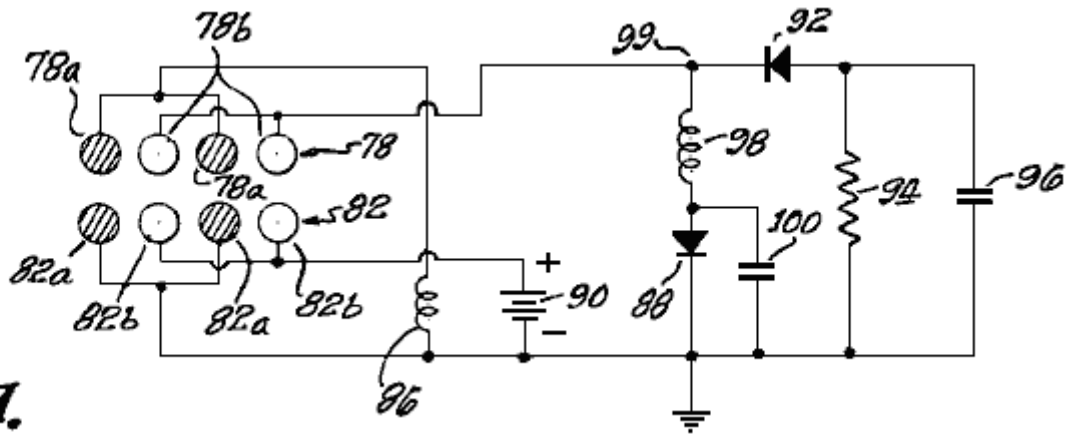

FIG. 7.

Fig.7 is a circuit diagram of another system incorporating the present invention;



FIG. 8.

Fig.8 is a series of curves illustrating the effectiveness of systems constructed in accordance with the present invention;

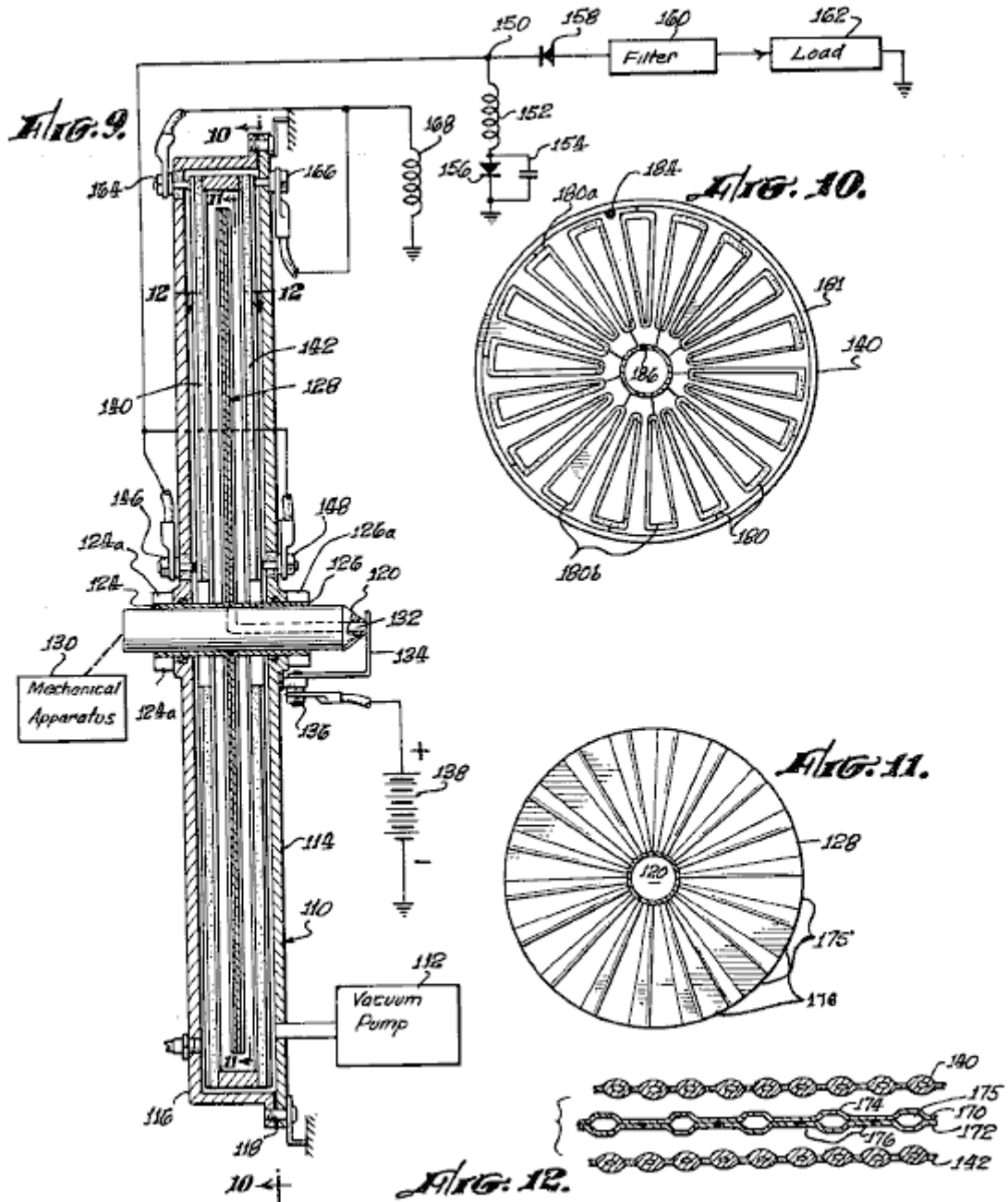
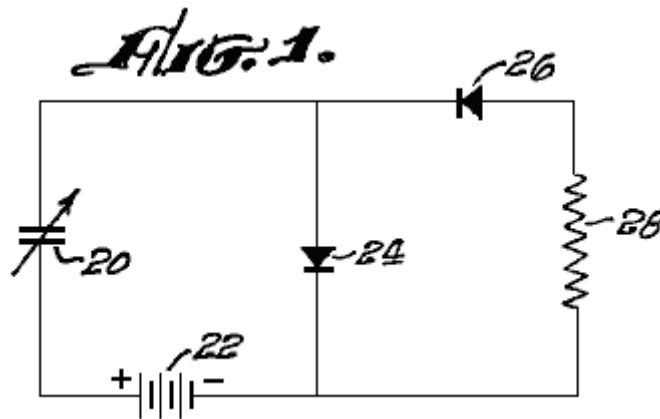

Fig.9 is a vertical sectional view and diagrammatic representation of an apparatus constructed in accordance with the present invention;

Fig.10 is a vertical sectional view along line 10 --- 10 of Fig.9;

Fig.11 is a vertical sectional view along line 11 --- 11 of Fig.9;

Fig.12 is a horizontal sectional view along line 12 --- 12 of Fig.9.



Referring initially to **Fig.1**, there is shown a preliminary form of an electrostatic induction generator. A variable capacitor **20** is connected in a serial loop with a battery (or other source of voltage) **22** and a diode **24**. A series circuit including a diode **26** and a resistor **28** is then connected across the diode **24**. The diodes **24** and **26** are connected in a way which allows current flow in opposite directions through the battery **22**. Variable capacitor **20** is driven by a motor to provide a cyclically-variable capacitance, with the result that the mechanical energy used to drive capacitor **20** is converted to electrical energy supplied to the load resistor **28**.

Considering the operation of the system of **Fig.1** in detail, capacitor **20** is driven to vary between maximum and minimum levels of capacitance. At a maximum level of capacitance, capacitor **20** is charged to a charge level "Q" by the battery **22** through diode **24**. The voltage across capacitor **20** then equals Q/C where C is the capacitance of capacitor **20**. Of course, this voltage coincides substantially with the voltage of battery **22** minus the voltage drop across diode **24**.

As the capacitance C of capacitor **20** decreases towards its minimum value, the charge Q remains constant; therefore the voltage across the capacitor increases to accommodate the decrease in capacitance as $V = Q / C$. The increased voltage across capacitor **20** produces a current through battery **22**, load resistor **28** and diode **26**. This current tends to recharge battery **22** as well as providing energy to the load resistor **28**.

In this manner, the mechanical energy used to drive capacitor **20** cyclically, is manifest in the form of electrical energy passed to the load resistor **28**. Therefore, in general, this basic operation of the electrostatic generator is similar to an electromagnetic generator, except that the field which couples the mechanical input energy to the electrical output energy is electrostatic rather than electromagnetic.

A wide variety of structures may be used as the variable capacitor in an electrostatic generator. However, in the selected structure, it is normally desirable to reduce the ratio of the peak field voltage gradients to the average gradients by using rounded capacitor elements, e.g. tubes or bars, rather than capacitor plates with sharp corners. Two variable capacitor structures using these conductive bars are shown in **Fig.2** and **Fig.3** and will now be considered in detail.

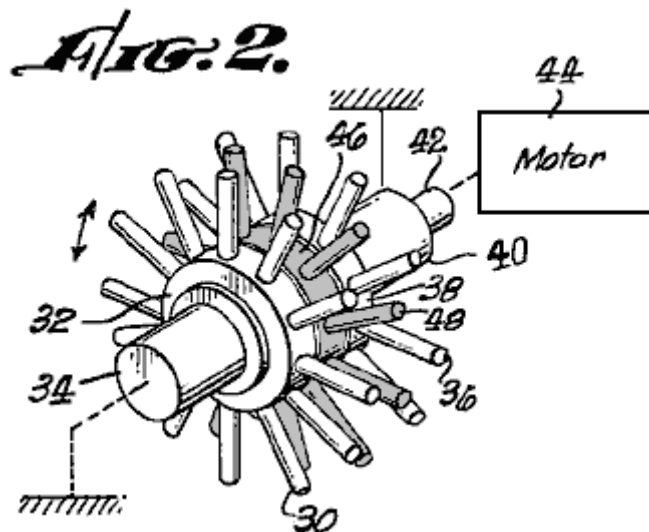

The structure of **Fig.2** is a radial-bar variable capacitor configuration where rows of radially-extending bars are mounted to be relatively moveable and so provide a variable capacitance between the rows. Specifically, a first row of bars **30** is mounted in a hub **32** which is carried on a fixed shaft **34**. Similarly, another row of radially-

extending bars 36 is supported in a hub 38 which is mounted on fixed shaft 40, which telescopically receives a concentric shaft 42 which is coupled to motor 44 and which carries hub 46 supporting the row of bars 48 which is positioned between rows 30 and 36. The bars in each of the rows 30, 36 and 48 may be interconnected electrically by a conductor supported in the respective hubs. However, as the individual hubs 32, 38 and 46 are formed of insulating material, the separate rows are not interconnected electrically. Therefore, a variable capacitance exists between the individual rows 30, 36 and 48. This capacitance is somewhat similar to a common rotating plate capacitive structure, however, in order to reduce the peak field voltage gradients between the rows, the bars or capacitive elements are rounded to avoid sharp corners.

At a time when the row of bars 48 is in angular alignment with the bars in rows 30 and 36, the bars are closest and there is maximum capacitance. As the row 48 revolves it reaches a position of least alignment of the bars in rows 30 and 36 (as shown in the drawing) and there, the capacitance between the rows is at a minimum. Therefore as motor 44 rotates the bars in row 48, a cyclically varying capacitance is provided between these bars and the bars in rows 30 and 36. In the application of this structure to the present invention, certain of the bars may be used to shape the electrostatic field as described below, while the remaining bars provide the desired variable capacitance. Of course, the number of rows provided in a configuration of this type may be varied to increase the capacitance, as may the size of the bars. Of course, these considerations are determined by the particular application of the system.

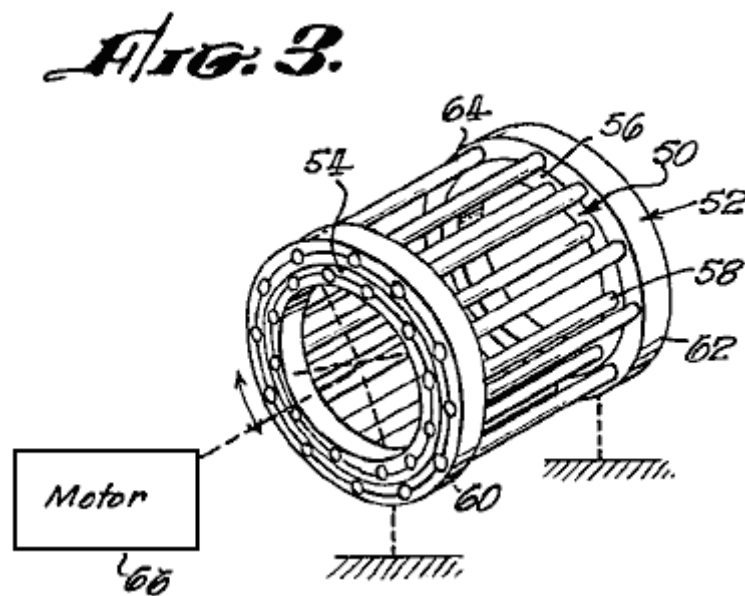

Fig.3 shows another form of variable-capacitance structure which may be used in a system of the present invention. The structure shown in **Fig.3** includes two concentric cylindrical structures 50 and 52, which are mounted so that they rotate relative to each other. These two structures are similar except for their size. The smaller structure 50 is telescopically fitted concentrically into the larger structure 52. The smaller structure 50 includes a pair of insulating rings 54 and 56 which are held spaced apart by conductive bars 58 and are angularly offset in a circular configuration. A pair of insulating rings 60 and 62 of the structure 52 are concentrically mounted outside the rings 54 and 56 respectively and are held spaced apart by angularly offset conducting bars 64. The structure 52, comprising the rings 60 and 62 and the bars 64 is held fixed, while the structure 50, comprising the rings 54 and 56 and the bars 58, is revolved making bars 58 and 64 pass each other in parallel relationship. As a result of this movement, a variable capacitance exists between the bars of the two structures. As in the structure shown in **Fig.2**, the individual bars in the separate structures may be interconnected electrically to provide a composite capacitance, or alternatively certain of the bars may be used for field shaping as described below. Thus the structure shown in **Fig.3**, as well as the structure shown in **Fig.2**, may be used as the cyclically-varying capacitance in the system shown in **Fig.1** to provide electrical energy from kinetic energy. In such a system, the energy would be provided by motors 44 or 66, however, the source of the kinetic energy is not important for the present invention.

In the operation of an electrostatic generator as shown above, the ratio of power conversion per unit size (and weight) of machine may be increased by increasing the maximum capacitance, or by decreasing the minimum capacitance of the variable capacitor. Of course, it is apparent that as the energy conversion is accomplished in systems of the present invention by a varying capacitor, the effectiveness of the conversion depends on the range over which the capacitor varies. In general, the efficiency of these systems is quite high even when operating with a small capacitive range, however, in such systems the energy conversion capability or power

rating of the system is low relative to its physical size. One major aspect of the present invention resides in a structure for increasing the range of capacitive change, and will now be considered in detail. For purposes of illustration, a moveable plate variable capacitor will be considered with reference to **Figures 4a, 4b** and **4c**. The flat plate capacitor provides a good example of the universal principle to be described because of the simple electrostatic field present in such a structure.

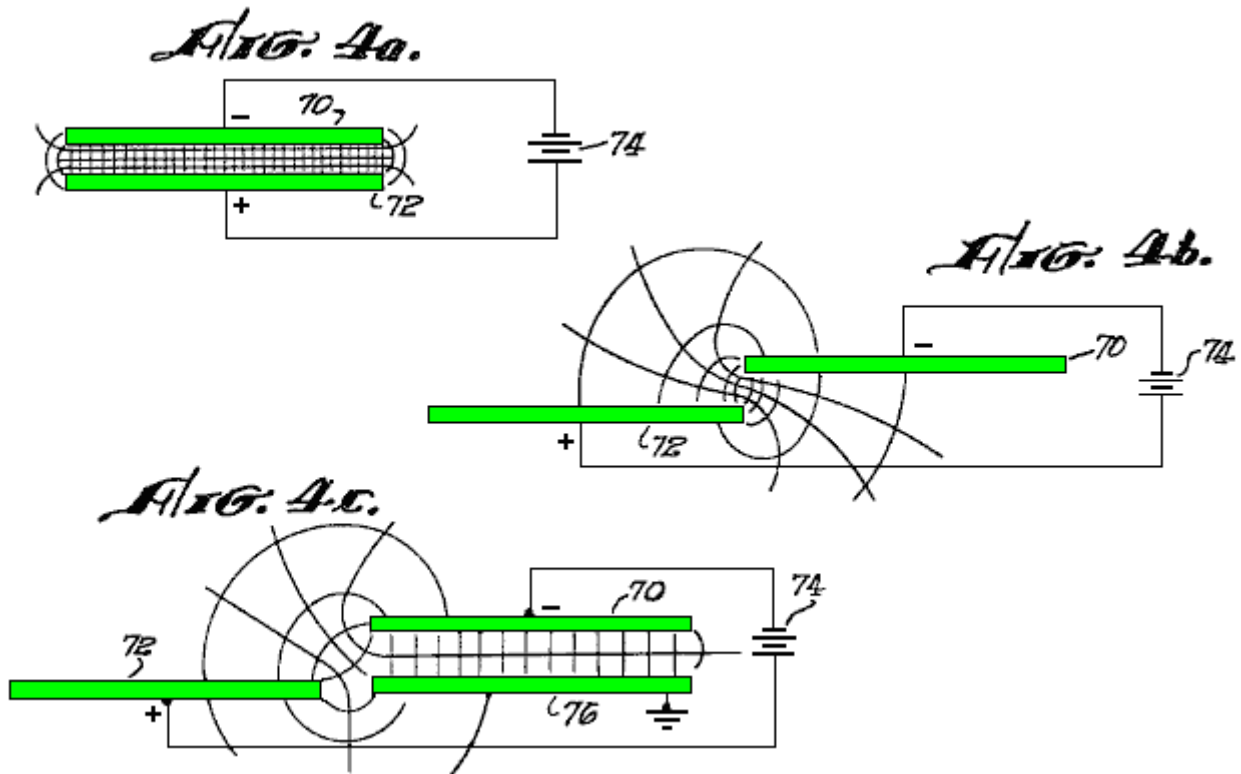

Fig.4a shows a pair of spaced-apart conductive plates **70** and **72** in face-opposing relationship and individually connected to the terminals of a battery **74** or other voltage source. The electrostatic field between plates **70** and **72** is indicated by lines of equal potential, and orthogonal flux lines which indicate the capacitance between the plates. **Fig.4b** shows plates **70** and **72** in an offset position, displaced out of face-opposing relationship to result in reduced capacitance between the plates. Again, the electrostatic field between plates **70** and **72** is indicated by lines of equal potential and the orthogonal flux lines which indicate the capacitance between the plates.

As previously mentioned, any arrangement which can result in greater capacitance for the plates in the configuration shown in **Fig.4a**, or reduced capacitance between the plates in the position shown in **Fig.4b**, results in more effective energy conversion in an electrostatic generator. The system of the present invention includes a structure for shaping the electrostatic field between plates **70** and **72**, to reduce the capacitance between them when these plates are in their position of minimum capacitance. This field-shaping is accomplished by adding extra conductors to influence the field between the plates.

Referring to **Fig.4c**, plates **70** and **72** are again shown in their position of minimum capacitance, however, another plate **76** is shown in face-opposing relationship to plate **70**. Plate **76** is connected to ground or other independent potential. As a result of this, an electrostatic field is provided between plates **70** and **76**, altering the field shape and the potential gradients, as shown in **Fig.4c**. The electric field and the capacitance between plates **70** and **72** is reduced substantially, while the maximum capacitance between these plates (when aligned in face-opposing relationship as shown in **Fig.4a**) remains substantially unchanged.

These same considerations apply in a similar fashion to bar conductors or other configurations of variable capacitors. Of course, the grounded or field-shaping plates as the plate **76** may be provided in both the stator and the rotor of a variable capacitor, or may be carried by only one of these structures.

Referring now to **Fig.5**, there is shown a system incorporating field-shaping electrodes and utilising capacitive structures comprising bars which may take the form generally illustrated in **Fig.2** and **Fig.3**.

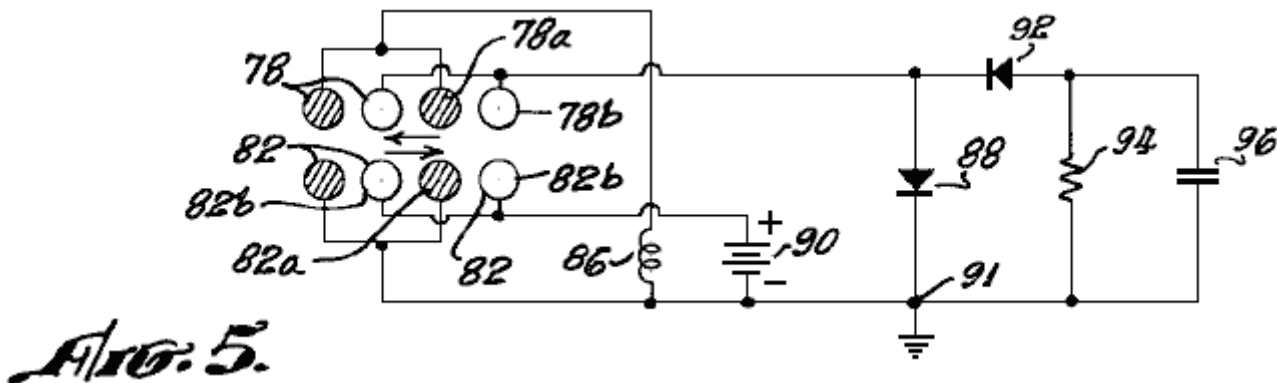

In **Fig.5**, the stator bars are diagrammatically represented aligned in one row **78** and the rotor bars are similarly shown to be aligned in an adjacent row **82**. Of course, either of the rows **78** and **82** may comprise a stator while the other comprises the rotor since relative motion is all that is necessary. However, in the prior art it has become somewhat common to term the rotor conductors as charge inductors while describing the rotor elements as charge conveyors.

In the system shown in **Fig.5**, grounded field-shaping electrodes or conductors are provided in both the row **78** and the row **82**, and are designated **78a** and **82a** shown shaded. The electrodes **82a** are connected directly to ground, however the electrodes **78a** are connected to ground through an inductor **86**. The function of this coil will be discussed later.

The conductive bars serving as capacitance elements in the two rows are designated **78b** and **82b** respectively. The bars **78b** (in the row **78**) and the bars **82b** (in the row **82**) are connected in a circuit configuration somewhat as shown in **Fig.1**. Specifically, the bars **78b** are connected in a serial loop with a diode **88** and a battery **90**. The junction point **91** between diode **88** and battery **90** is grounded, and a diode **92** serially connected with a load resistor **94** is connected across diode **88**. A capacitor **96** is connected across the load resistor **94**, and serves as a filter for the load current.

In the operation of the system, relative movement is provided between row **78** and row **82** producing a cyclically variable capacitance to cause the system to function as the system shown in **Fig.1**. That is, during the interval of high capacitance between the rows **78** and **82** (as shown in **Fig.5**), the capacitive structure is charged by battery **90** through diode **88**. Then, as the bars are separated to reduce the capacitance, the voltage across them increases, causing a current to flow in the opposite direction through battery **90**, the load resistor **94** and diode **92**. As alternate bars in each of the rows **78** and **82** are grounded, the electrostatic field is shaped to reduce the minimum capacitance between the bars **78b** and **82b** as disclosed in **Fig.4**. As a result, the capacitance variation is greater and more charge is transferred through the load during each electrical cycle.

In the operation of the system shown in **Fig.5** to convert mechanical energy into electrical energy, a generally capacitive electrical system is provided. Therefore the phase relationships within the system are generally those of a capacitive apparatus. In view of this, the present invention includes the provision of inductors to produce phase shifts and resonant voltage amplifications which increase the effective power-conversion capabilities of the system. In **Fig.5**, such an inductance **86** is connected between the bars **78a** and ground. The operation of the system of **Fig.5**, including the inductor **86** is graphically illustrated in **Fig.6** which includes plots of capacitance, voltage and electrical current versus the position of the capacitive structure.

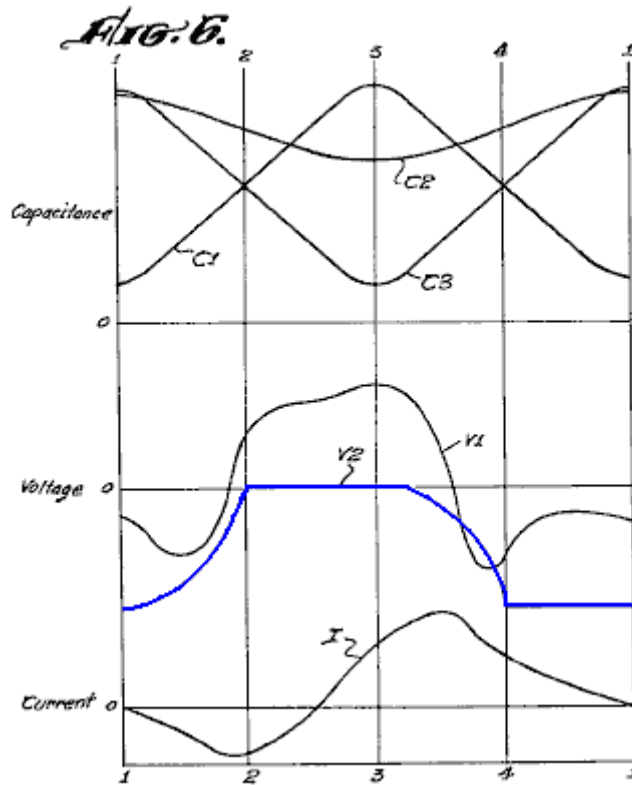

The upper family of curves are capacitance plots, in which, curve **C1** is a plot of varying capacitance between the conductive bars **78b** and **82b**. The curve **C2** is a plot of the capacitance between bars **78a** and **82a**, while the curve **C3** is a plot of the capacitance between bars **78a** and bars **82b**. These curves are plotted against a uniform variation in relative positions between row **78** and row **82**, the curves beginning at a point of minimum capacitance for the structure. **Fig.5** illustrates the relative position marked as **3** in **Fig.6**.

The voltage curves in **Fig.6** are plotted on the same base as the capacitance curves, and include a curve **V1** which represents the voltage across coil **86**, and a curve **V2** which represents the voltage on the bars **78b** relative to ground potential. The curve **I**, illustrates electrical current flow through inductor **86**, and it is also plotted with respect to capacitive displacement.

Considering the operation of the inductance **86**; in view of the capacitance between the grounded bars **78a** and the capacitively-charged bars **82b** (connected to battery **90**) a charge is deposited on the bars **78a**. Of course, in the absence of the inductance **86**, this charge would be immediately passed to ground. However, by providing the inductance **86**, the voltage of curve **V1** is developed across this element. This voltage serves to produce further field shaping between the bars and results in more efficient power conversion. That is, the voltage of curve **V1** appears on the bars **78a** in phase with the capacitance **C1** so that the field influence of bars **78a** serves to increase the charge induced at or near the maximum of capacitance **C1** and also serves, by reducing the field strength to reduce the minimum charge held on bars **78b** and **82b** at, or near the instant of minimum capacitance. Thus the variation in the electrostatic field causes the system to absorb more torque, resulting in increased power-conversion capability for the system.

In addition to the provision of inductor **86** as shown in **Fig.5**, other circuit configurations using inductors are to further affect resonant current surges which increase and decrease the field voltages in proper phase relationship with the capacitance variation, and so increase the amplitude of the capacitor alternating current. One such other variation is shown in **Fig.7** which uses bars similar to those of **Fig.5** and in which, like elements are similarly identified.

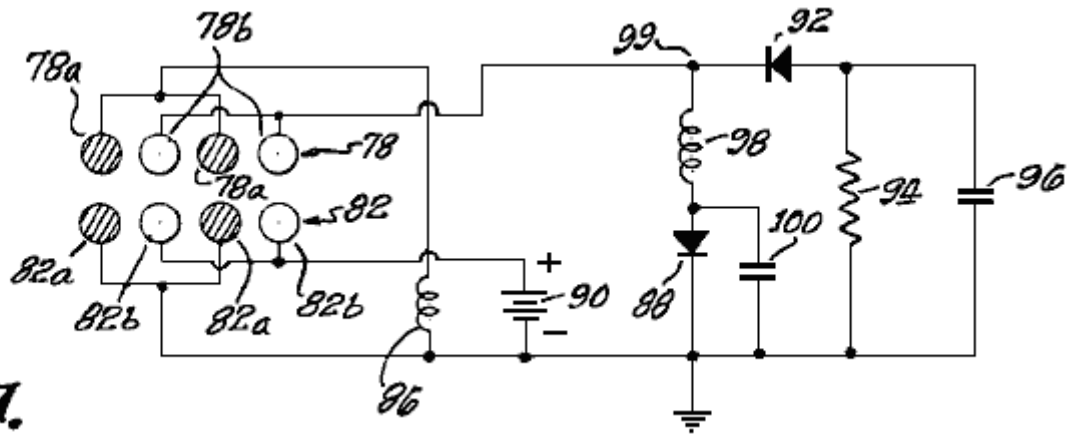

FIG. 7.

In the system shown in **Fig.7**, an inductor **98** is connected between diode **88** and the junction point **99** between diode **92** and the bars **78b**. Furthermore, a capacitor **100** is connected across diode **88**. In general, the added resonant circuit provides further current surges in the desired phase relationship with the variation of capacitance. Also, the resonance between inductor **98** and capacitor **100**, tends to produce higher voltages in the electric field of the variable capacitor relative to the voltages across the excitation source **90** and the load **94**. The capability of the machine to achieve high power from a small size of variable capacitor is thereby greatly improved.

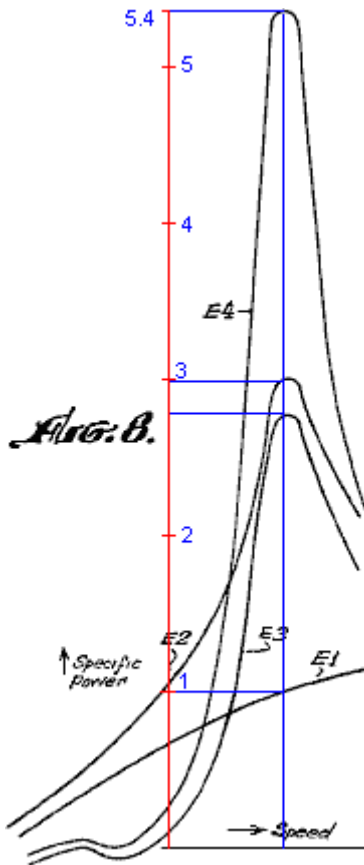
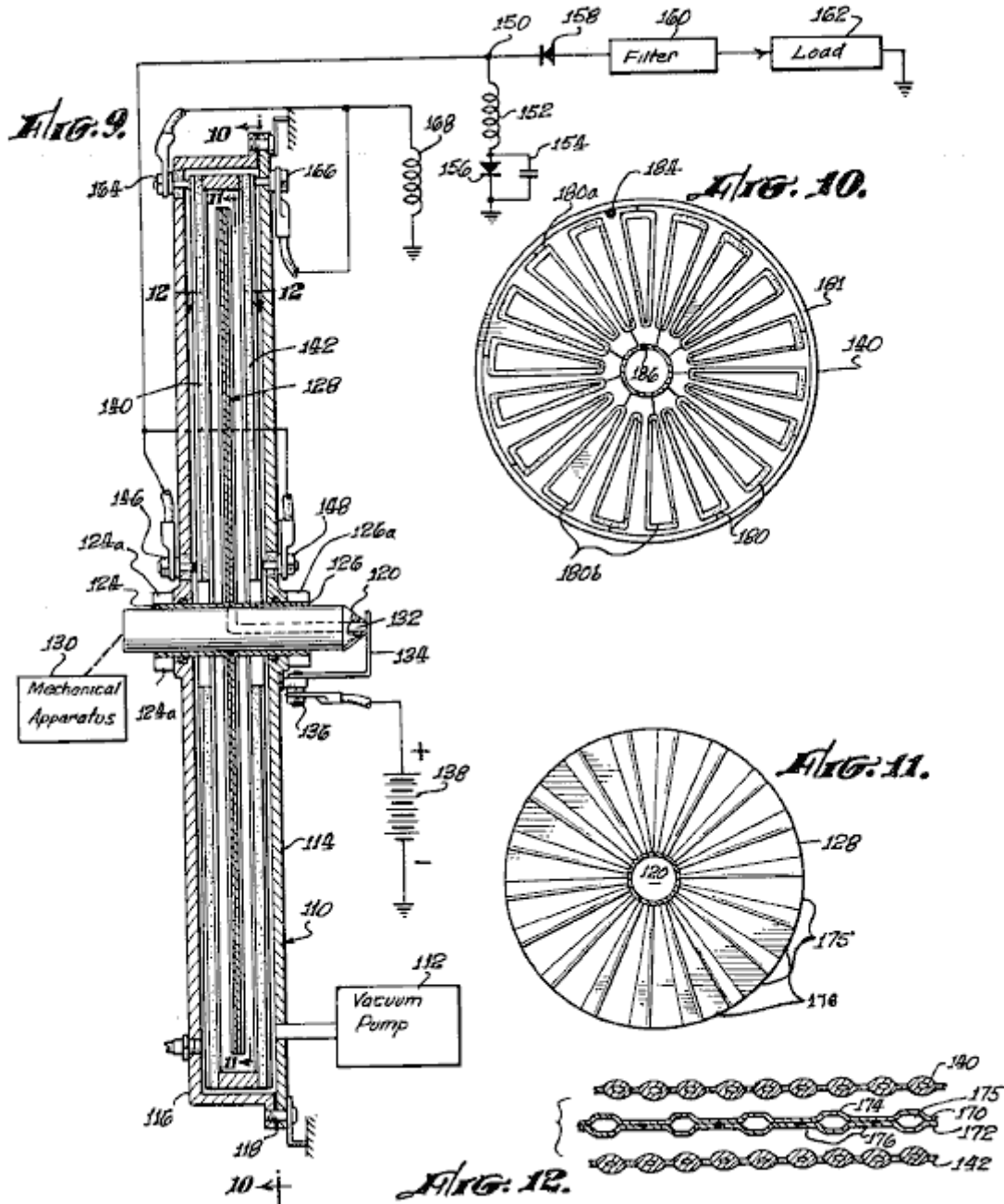

FIG. 8.

A graphic indication of the improvement to a system resulting from the application of certain principles of the present invention may be seen in **Fig.8** which includes several curves descriptive of various apparatus, and wherein speed is plotted along the horizontal axis versus specific power which is plotted along the vertical axis. Specific power is herein defined as the power output per unit of excitation voltage squared (P/E_o^2) for a given size and configuration of machine.

The curve **E1** is indicative of the operating characteristic of the simple system shown in **Fig.1**. The curve **E2** (indicating a substantial improvement in performance) is indicative of the system shown in **Fig.5**. The curve **E3** indicates the improvement of the system of **Fig.7** (without the aspect described with respect to **Fig.5**), while the curve **E4** indicates the operation of the system shown in **Fig.7** as illustrated there.

It is apparent that the power conversion capabilities of the system of **Fig.7** (indicated by the curve **E4**) are greatly improved over the simple system which does not include these aspects of the present invention, particularly if the generator is operated at a fixed speed, or if means are provided to adjust the inductance or capacitance values of components **86, 98** and **100** to give the tuned peak power at whatever speed the machine is being operated.



Although various aspects of the present invention may be differently applied to electrostatic machines, to accomplish the desired results, one specific illustration of an operating machine is shown in **Figures 9, 10, 11 and 12**, and will now be considered in detail.

The system is mounted in a housing **110** which is sealed and maintained evacuated by a vacuum pump **112**. By operating the cyclically-variable capacitor apparatus in a relatively high vacuum, insulation problems are reduced and windage losses are minimised. The housing **110** has a flat cylindrical form and consists of a circular plate bolted to a cup-shaped member **116** with an annular seal **118** provided at the junction between these members.

A mechanical shaft **120** passes concentrically through housing **110** and is journal led into bearings **124** and **126**, which incorporate vacuum seals **124a** and **126a**. The shaft **120** has a rotor **128** coaxially fixed on it and is connected to a mechanical apparatus **130** by which the shaft is driven. Shaft **120** (made from insulating material) has a conductive section **132** formed in it, which electrically connects rotor **128** through a brush **134** and a lug **136** to one terminal of a battery **138**, the other terminal of which is grounded.

In general, the basic electrical system is similar to that of **Fig.7** with the stator elements being connected by lugs **146** and **148** to a junction point **150** which is connected through an inductor **152** and a capacitor **154** to ground. A diode **156** is connected in parallel with capacitor **154**. The junction point **150** is also connected through diode **158** to a filter **160** which is in turn connected to a load **162**. The field-shaping electrodes in the stator elements **140** and **142**, are connected from lugs **164** and **166** through an inductor **168** to ground.

Considering the cyclically-varying capacitance apparatus in greater detail, the rotor comprises a pair of plates **170** and **172** (**Fig.12**), which are formed with angularly-offset radiating grooves **174** which are interconnected by spot welds **176** so that the grooves **174** essentially form radiating bars **175**. In this structure, the rotor is entirely conductive material, e.g. metal, formed to comprise radiating tubes **175** (**Fig.11**) which are connected through the shaft conductor **132** and the brush **134** to the battery **138**.

The stator components **140** and **142** are similar and comprise a plurality of tubes **180** (**Fig.10**) radiating in a plane from an axial location in the stator element and supported in a circular stator mounting **181** by being imbedded therein. Tubes **180** are formed of metal and the mounting **181** supporting the tubes is formed of insulating material as a casting of epoxy material. Alternate of the tubes **180** are designated **180a** and are connected electrically to a terminal **184** which is contacted by one of the lugs **146** or **148** at a point **186**.

The lugs **164** and **166** are connected to ground through inductor **168**, with the bars **180a** used as field-forming bars while bars **180b** are the actual variable-capacitance elements. In this structure, only the stator is provided with field-shaping electrodes; however, it is to be understood, that in various other embodiments, field-shaping electrodes may be provided in both the stator and the rotor, or in only one structure, as taught with respect to **Fig.5** and **Fig.7**. Also, in the system shown in **Fig.9**, only a single rotor plate is provided; however it is to be clearly understood that a large number of intermeshed rotor and stator plates may be provided in systems of the present invention, depending on the rated power conversion capability of the system.

In the operation of the system shown in **Fig.9**, rotor **128** is revolved relative to the stator elements **140** and **142** by the mechanical apparatus **130**. Therefore, the tubular rotor bars are driven in and out of alignment with the radiating stator bars **180b**. Therefore the connections to these elements (lugs **146** and **148**, and brush **134**) experience a cyclically-varying capacitance. The stator bars **180a** extend the range of this capacitance in the manner described with respect to **Fig.4**.

During intervals of high capacitance, the cyclic capacitive structure is charged by battery **138** through inductor **152** and diode **156**. As the capacitance of the structure decreases, the voltage therein increases, providing a current through diode **158**, and filter **160** to the load **162**. Thus, mechanical energy from the mechanical apparatus **130** is efficiently converted into electrical energy and supplied in that form to the load **162**.

While the previous discussions have pertained primarily to electrostatic generators, it is to be understood that the important features of the present invention apply equally to electrostatic motors.

An important feature of the present invention resides in the structure disclosed in **Fig.9**, which may be economically manufactured and used in practical electrical systems.

Another important feature of the invention resides in the use of field-forming electrodes in the stator or rotor, or both the stator and the rotor to accomplish more effective energy transitions.

One other important feature of the invention resides in the provision of inductance elements to further increase the effectiveness of the system.

The Onezime Breaux Electrostatic Generator

US Patent 4,127,804

28 Nov. 1978

Inventors: Onezime Breaux

ELECTROSTATIC ENERGY CONVERSION SYSTEM

This is an important design, but as the physical details in the patent seem rather limited, instead of reproducing the patent here, I will attempt to provide a description which should be more understandable for the average person.

The Principle

For there to be a greater energy output than the energy input required to make any generator operate, that extra energy must come from somewhere. There is no magic about any of these systems as we ourselves are immersed in a massive energy field. We do not notice this any more than we notice the radio waves which pass by, and through us, all the time. This energy field is very powerful as Thomas Henry Moray demonstrated many times by gaining fifty kilowatts of electrical power from just a simple aerial and a ground connection. We don't know how he did that, but we would very much like to know how. Nevertheless, Moray demonstrated that there is massive power all around us – power which is free for the taking if we know how to do it. Unfortunately, most of the large number of people who do know how to extract this energy, refuse to share that information, leaving us to work out from basic principles, how to gain this free-energy. It should be noted in passing, that we already use this free energy when we use "mains electricity" as none of the energy supplied by the local Power Company actually comes out of your mains wall socket since all of the current supplied by the Power Company flows directly back to that company. All the Power Company does is to set up the conditions which cause some of the free-energy in your location to flow through the electrical equipment which you plug into that wall socket. What free-energy devices do, is to set up those same conditions to draw in electricity from our massive surrounding energy field, without the need for any help from the local Power Company.

The Design

When you try to start a car engine, you connect the car battery to an electrical Starter Motor which turns the engine over and causes sparks to be generated inside each of the cylinders of the engine. The current draw from the battery passes through the Starter Motor and is lost for ever. If the car engine starts, then some of the energy stored in the fuel burnt by the engine is used to replace the electrical current taken from the battery. If the car engine does not start, then after a fairly short time, all of the electrical energy stored in the car battery will be fed to the Starter Motor and the battery will no longer be able to supply any more current to turn the engine over.

The generator described here is a very clever design as any output power which it provides, it keeps and does not lose any of it. It is somewhat like that car Starter Motor returning the current to the battery, allowing any number of attempts to start the engine. The way that it operates is to pass current backwards and forwards between two capacitors. That current is made to pass through the primary winding of an output transformer, exactly mimicking the signal which the Power Company charges you for. However, with our generator, that current is never lost and can be used over and over and over again. A battery is used to create that initial current, and when the generator starts operating, it recharges the battery and if desired, the battery can be removed completely and the generator is then self-sustaining. The battery is only used to start the generator running and is not used at any other time.

The outline design is very straightforward and can be visualised as shown here:

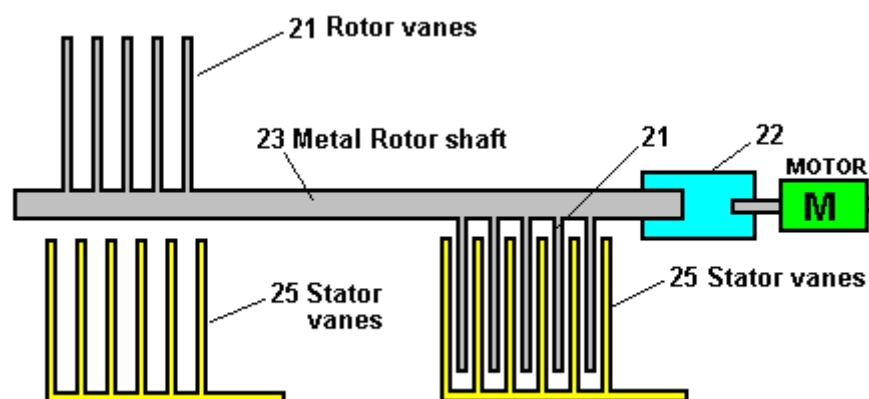

Here, the motor marked **M** in the diagram, spins a metal shaft **23**. The shaft is mounted on ceramic roller bearings (as used on skateboards) and nothing on the shaft touches any other part, which means that the shaft spins very freely and very little power is needed to spin it.

Shaft **23** has metal 'vanes' or plates **21** attached to it and these pass through somewhat similar metal vanes **25** which are fixed in place and do not move. These four sets of metal vanes form two separate variable capacitors.

The vanes **21** are arranged so that when one set reaches its maximum capacitance (being fully inserted into the non-moving vanes **25** as shown on the right of the diagram) then the other set of vanes is at its minimum capacitance being as far away as possible from its matching set of vanes **25**.

Initially, at start-up, both of the sets of vanes marked **25** are fully charged to a high positive voltage by an electrical system (not shown here) and the output transformer is connected between these two sets of vanes, producing this arrangement:

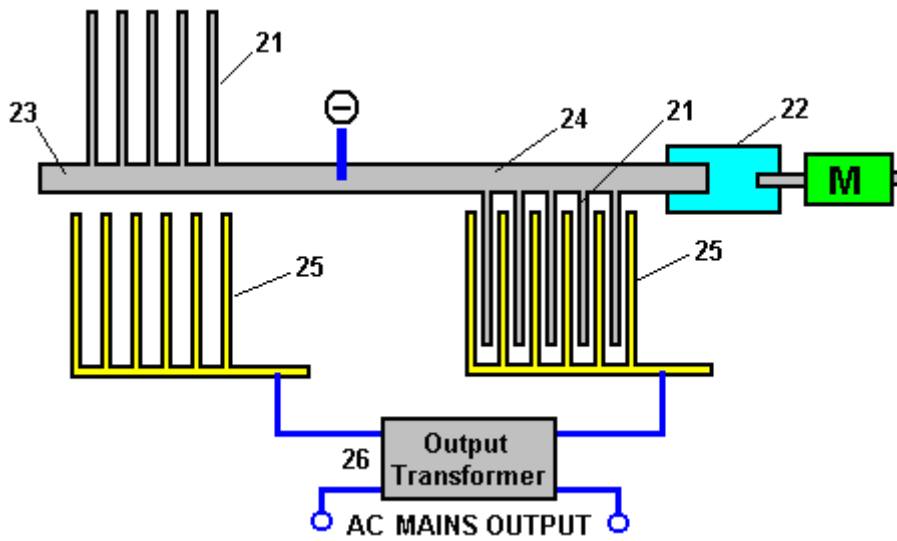

The sets of vanes **21** are connected to a strongly Negative charge, passed to them through the metal shaft **23**. When the negative plates **21** are inserted between the Positively charged plates **25**, all of the positive charge on the unmeshed plates **25** gets sucked towards the negative charge on the meshed plates **21**, but that charge is forced to flow through the output transformer on it's journey. This arrangement causes the positive charge on the fixed plates to shuttle backwards and forwards through the output transformer, never getting 'used up' in the process. This means that the generator has an electrical output of 220 volts at 50 cycles per second and the only input power needed is the tiny amount required to spin the rotor shaft. The force needed to spin the rotor shaft is not affected in any way by the intensity of current drawn from the output transformer, which means that the generator is wholly independent of the load. While this is a very clever design, a number of practical construction details can be altered to improve the performance.

The Breaux patent shows a vane shape which doubles the frequency at which the drive motor spins and which is balanced on the shaft, producing no shaft vibration when spun rapidly. The vane shape is shown here:

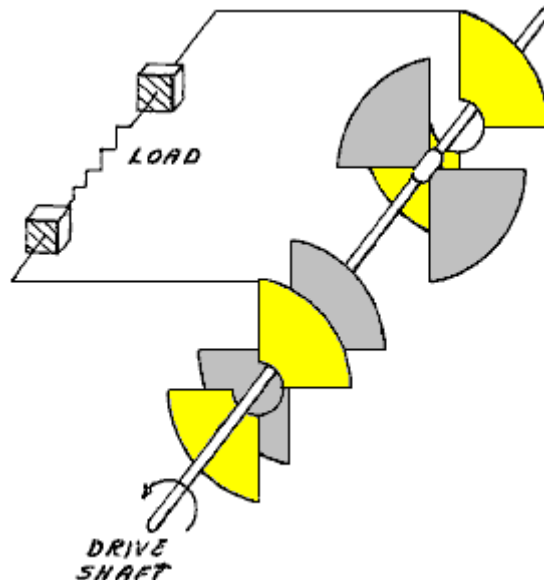

You will notice that the rotor vanes (shown in grey), are positioned ninety degrees apart, providing even better shaft balance. All of the rotor vanes have the same shape and all of the stator vanes have the same shape, which is helpful for mass production. While just two rotor vanes and two stator vanes are shown in this introductory diagram, there can be as many pairs of rotor/stator plates as desired. Each additional pair of plates increases the output power of the generator.

This design calls for the vanes to be in a vacuum, which strongly suggests that this device was never prototyped as operating in a vacuum, unless all conducting surfaces have exceptional insulation, would be a major disaster

as the coronal discharge would be massive – after all, that is how thermionic valves or ‘vacuum tubes’ are made and they carry large electrical currents through a vacuum. For this design to function properly, it needs to be operated in dry air.

The power output of a device of this nature increases with increasing vane area, and with decreased inter-vane gap and with increased voltage. Consequently, a working voltage considerably higher than 220 volts will be used when charging the vanes. This means that the output voltage will be much higher than is convenient. Generators of this type generally show a resistive load and only a resistive load. A practical implementation would require a step-down transformer on the output in order to reach a working AC voltage of 220V. It is generally thought that the inductive nature of the primary winding of any such transformer would create a major choking effect on the oscillating flow of charge between the vanes, due to the back-EMF of that winding. That is not the case if a Thane Heins style of transformer is used (as shown in chapter 3) as a transformer of that type does not have any significant back-EMF, making this a very interesting design, especially since the output current draw does not affect the input power which is solely used to spin the rotor shaft.

In theory, the static charge initially placed on the capacitor vanes is never depleted. However, in this world, perfect conditions never seem to be encountered. In this instance, there is a **very** slight loss of charge over time, and that charge is boosted very briefly after a substantial time has elapsed. A brief high-voltage pulse once every ten minutes is likely to be sufficient. There is no corona energy loss as corona streamers only form at high frequency and this generator does not exceed an absolute maximum of 60 Hz which is a very low frequency indeed, so there is never any corona discharge at all.

Patrick Kelly

<http://www.free-energy-info.tuks.nl/>

Chapter 8: Fuel-less Engines

We have been raised with the idea that it is necessary to burn a fuel to produce power which we can use. We are sold coal, coke, timber, paraffin/kerosene, petrol/gasoline, diesel, propane, etc. for us to burn in order to “get” energy. While it is perfectly true that burning these things will indeed result in energy in a form which we find convenient to use in heating, cooling, powering engines, etc. what is carefully avoided is the fact that it is not at all necessary to burn a fuel in order to run the things which we want to power. This ‘inconvenient’ fact has been concealed and denied for more than fifty years now (very surprisingly, by the people who want to sell us these fuels to burn – do you perhaps think that they may have some motive for this, other than our best interests about which they are no doubt, very concerned?).

This chapter is about ‘fuel-less’ motors. Strictly speaking, they are not self-powered but as they don’t burn a fuel of any kind, in everyday language they can be described as ‘self-powered’. In the same way that a solar panel in sunlight uses no fuel and yet puts out electrical power, these motors draw energy from the environment and provide us with mechanical power. In actual fact, power is never “used up” but just converted from one form into another. In the case of our trusty solar panel, some 17% of the radiation from the sun (mainly ultraviolet) is **converted** into electrical power and 83% goes in heating and other losses, but as we don’t have to supply the sunlight, and the solar panel pours out the electricity which we want without us having to do anything to make it happen, we really don’t care very much about its extremely low efficiency. As far as we are concerned, the electricity flowing from the panel is “free-energy”.

It is really amazing that we have been persuaded that we must burn a fuel in order to get power. Take the case of a heavy-displacement sailing yacht. The skipper can voyage using his inboard diesel engine:



This matches perfectly with the thinking that you need to burn a fuel in order to get power as the yacht is moving along, pushed by the engine which is powered by burning diesel fuel. But, what if the skipper decides to switch the engine off and set the sails?:



Now, the same boat, weighing exactly the same with the same crew, is now continuing the voyage at the same speed, but no fuel is being burnt. The really interesting thing is that while we know this perfectly well, and we are aware that people have sailed right around the world in boats which do not have engines, it does not seem to occur to us that this shows conclusively that it is not necessary to burn a fuel to power some item of equipment or form of transport.

In the case of our yacht, the energy comes from the sun which heats the atmosphere unevenly, causing winds to blow and the yachtsman uses the sails to make those winds power his boat through the water. So, a sailing boat is actually powered by the sun although we don't usually think about it that way.

There are many hydro-electric "power stations" where electricity is 'generated' by machines driven by water pressure. In actual fact, no power is 'generated' at all, but instead, the potential energy of the body of water is **converted** into electricity by having the water fall and spin the shaft of a machine. So, how did the water get up there in the first place? Well, it came from rain. And how did the rain get up there? It rose up there due to evaporation caused by the heat of the sun. So, the bottom line again is that hydro-electric 'power' stations are powered by the sun.

Windmills are also powered by the sun. But, and here is the really interesting thing, if I state that it is perfectly possible for a compressed-air engine to produce mechanical power without burning any fuel, then there is an immediate and strong reaction where people will say "Impossible – that is perpetual motion !!" They imply that perpetual motion is impossible but never supply any rational evidence to support that implication. The Earth has been spinning on its axis for millions of years, so when exactly do they expect it to stop? All the planets in the Solar System have been orbiting for millions of years, how long do they have to orbit before they can be considered to be in perpetual motion? Why then are people so opposed to the idea of perpetual motion? Presumably, because perpetual motion shows clearly that a fuel does not have to be burned to 'produce' power and that would not be good for people who sell fuels, and so, we are all told from an early age that perpetual motion is "impossible".

Well, that does not matter here as we are going to look at compressed-air engines which run off the heat of the sun. That is, they are heat-pumps which are a well accepted engineering fact and they work on wholly accepted standard scientific principles. An ordinary refrigerator outputs three or four times as much heat power as the electrical power driving it, and it could be twice that efficient if it were used properly. This is a Coefficient Of Performance (COP) of 3 or 4, which is supposed to be "impossible" but unfortunately, all refrigerators work like this and you can't exactly say that refrigerators don't exist, just because their performance does not appear to fit in with some theories.

Actually, there is no magic involved here as the extra energy is being drawn from the heat content of the air in the immediate locality. The refrigerator is not operating in isolation and there is a heat exchange with the air surrounding it. This outside energy causes the COP>1 performance. In passing, all COP>1 devices operate by drawing energy in from an external source (usually the zero-point energy field) and none of them actually break the 'rules' of science. But, enough of that.

The people who don't want self-powered engines used in the world today, pin their hopes on a continued ignorance of Engineering facts relating to heat pumps. A self-sustaining compressed-air engine is actually running off power from the sun just as sailboats, windmills and hydro-electric power stations do. Sorry folks, no magic here, just bog-standard Engineering. Admittedly, very few people know or realise the implications of this standard Engineering:

1. All work done in compressing air into a storage tank is converted into heat and then lost to the atmosphere, so the energy in the compressed air inside the tank is the same as that produced by atmospheric heating of that air, but as more of it is now in the tank, there is additional potential for work to be done. This extra energy was fed into the air by atmospheric heating before the air was compressed.

The First Law of Thermodynamics states that where heat is converted into mechanical energy, or mechanical energy is converted into heat, the quantity of heat is exactly equivalent to the amount of mechanical energy. We then have the intriguing situation where all of the mechanical energy put into compressing air into a storage tank is lost as heat, and yet, the tank contents now has a higher potential for doing work. This information comes from Engineering textbooks.

2. If the expanded cold air leaving the engine is used to cool the intake air of the compressor, then there will be an added gain when it warms up inside the cylinder, pulling heat in from the local environment.

3. If the heat of compression is transferred to the air container feeding the engine and not given time to dissipate, then there is a further power gain for the engine.

4. If compressed air is allowed to expand rapidly, there is a marked drop in temperature. The Leroy Rogers engine design, shown later in this chapter, uses this fact to create air-conditioning for a car driven by a compressed-air engine.

OK then, in broad outline, the energy available from a tank of compressed air comes directly from the heat contained in the atmosphere, in spite of the fact that we always imagine that the energy in the tank was put there by our energetic pumping.

Let's check this out by taking a look at some of the engines which use these principle to provide fuel-less operation, starting with the design of Bob Neal. The full patent for Bob's design is included in the Appendix.

Bob Neal's Compressed Air Engine.

Bob Neal's design is a compressed-air operated engine and compressor where the operation of the engine keeps re-supplying the compressed air tank:

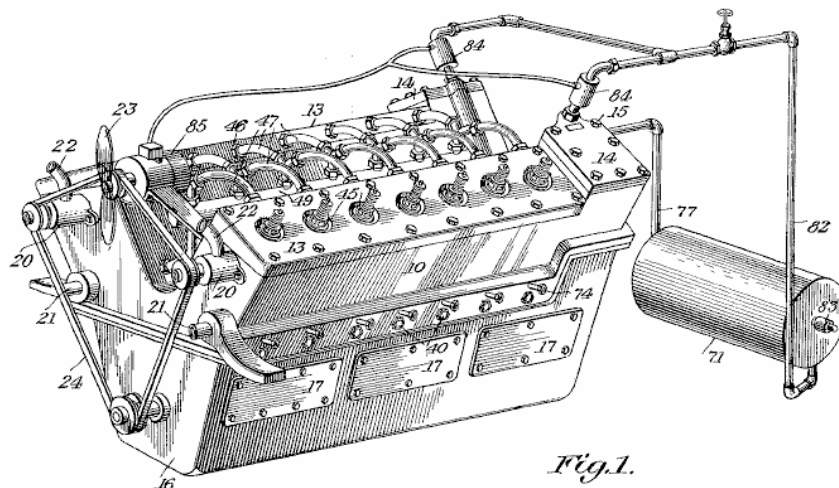

This is a perspective view of the engine and this:

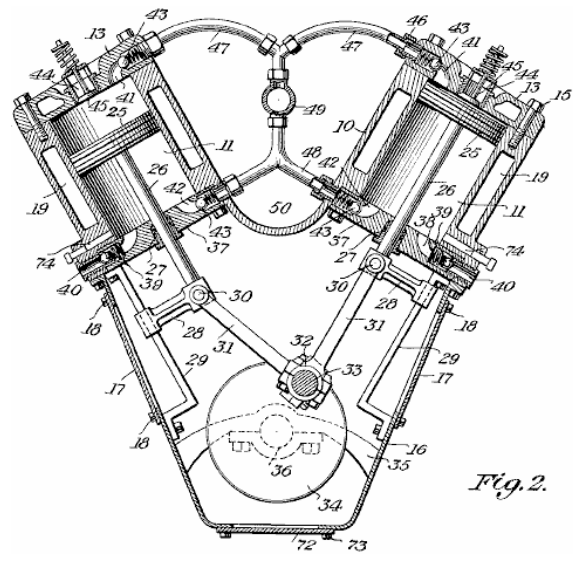
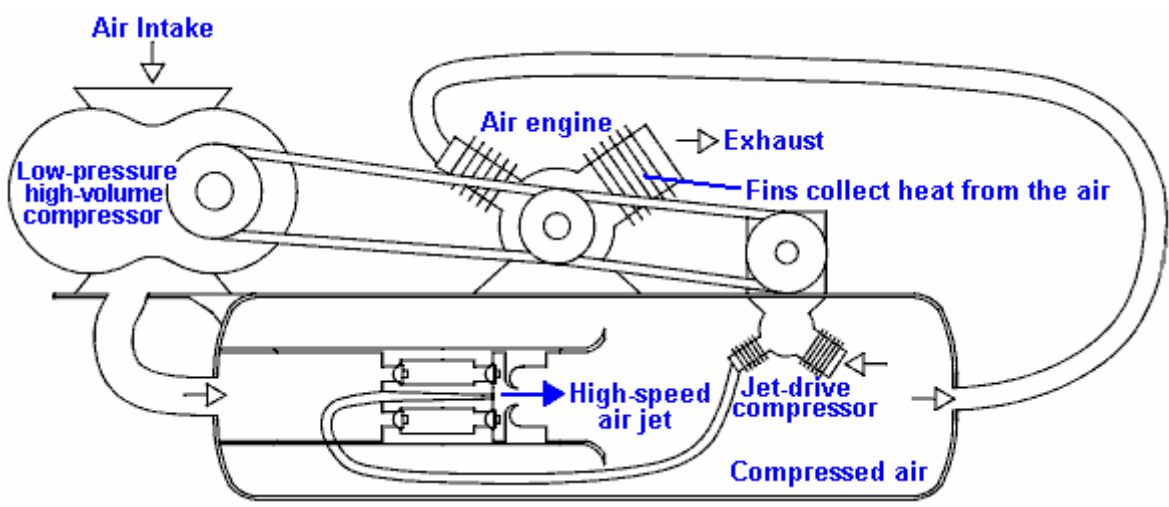

Fig. 2.

is a vertical transverse cross-section view through the compressor part of the engine. In his patent, Bob has avoided any direct mention of the fact that his engine design is fuel-less. That sort of statement is not popular with Patent Examiners even if it is perfectly true.

Scott Robertson's Compressor System.

Bob Neal's system could do with some further explanation, so here is an idea from Scott Robertson whose web site is <http://www.aircaraccess.com/index.htm>, for a possible working compressor system using a leaf-blower:



While this looks rather complicated, in reality it really isn't. Let's take the different sections in order:

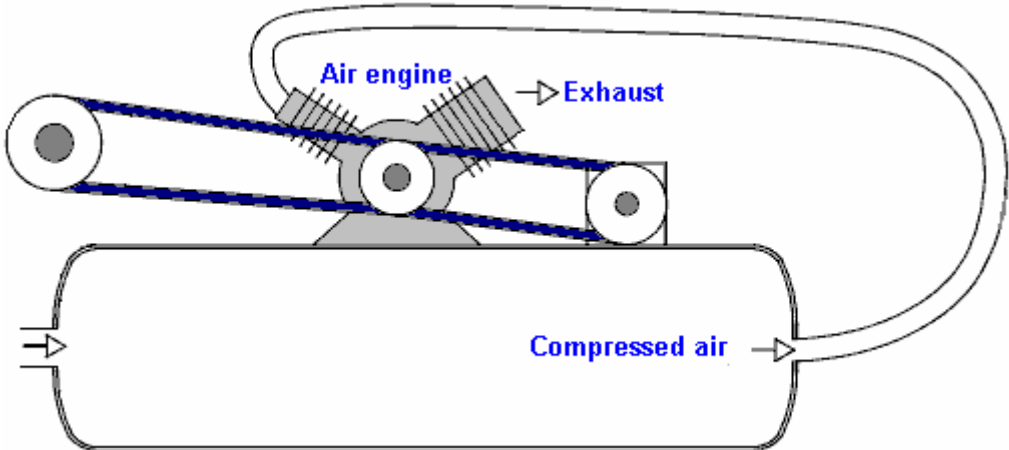

First, you have an ordinary air engine, supplied with compressed air from a pressure tank. This engine exhausts its (cold, expanded) air to the atmosphere. The engine powers two compressors which between them keep the tank full of compressed air.

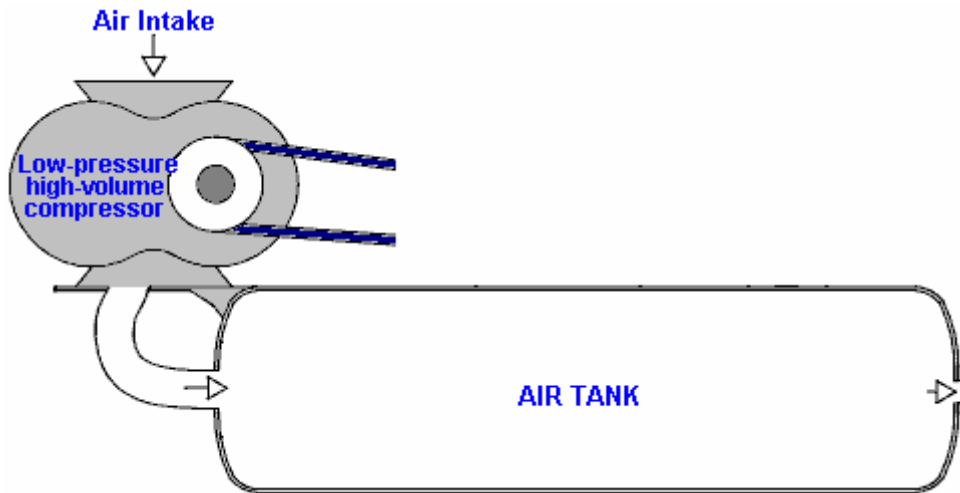

The first compressor is a simple 'leaf-blower' type which produces a large volume of low-pressure air. The big question is "how do you get this large volume of low-pressure air into a tank which has high-pressure compressed air inside it?". Well this seemingly impossible task is performed by the second compressor aided by a cunning, ultra-simple design:

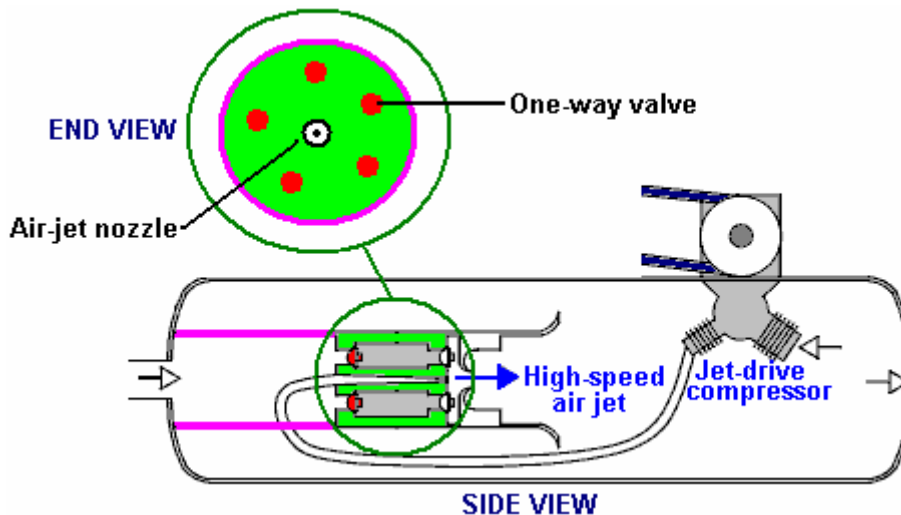

Here, low-pressure air is fed into the low-pressure area marked in pink. Separating it from the high-pressure area is a metal plug marked in green. Set into this plug is a ring of five one-way air valves marked in red. These one-way valves let the low-pressure air into the high-pressure area because of a high-speed jet of air produced by the 'jet-drive compressor'. At first glance, this seems impossible, but it is actually just an application of a standard Engineering technique. The high-speed air jet is directed through a specially shaped nozzle, creating a local low-pressure zone around the jet:

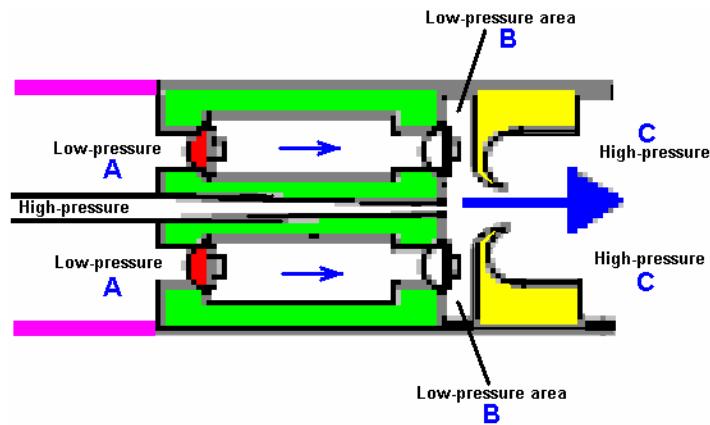

The low-pressure air at point “A” flows through the ring of five one-way valves into the disc-shaped low pressure area “B” and is blasted into the high-pressure area “C” by the high-power air jet ripping through the doughnut-shaped ring marked in yellow. The high-speed air jet causes the low pressure ring “B” by its rapid movement which creates a vortex due to the shape and positioning of the doughnut-shaped ring marked in yellow. This clever arrangement allows large volumes of low-pressure air to be drawn into a tank which contains high-pressure air.

You will also note that the two-stage compressor which generates this high-speed jet of air, has its working area actually inside the tank. This means that the heat of compression is used to heat the air inside the tank and raise its pressure, enhancing the operation further. It should be borne in mind that the new air entering the system has been heated by the sun and contains the energy which powers the system.

The Retro-fit Compressed Air Vehicle System of Leroy Rogers.

The Rogers motor shown here makes no claims to spectacular operation, but in spite of that, Leroy did admit in an interview that this motor does indeed have a greater output than the applied input, provided that the motor is not left just ticking over. This motor is like the US patent 3,744,252 “Closed Motive Power System Utilising Compressed Fluids” by Eber Van Valkenburg shown below. However, the Rogers patent shown here has the distinct advantage that it uses off-the-shelf motors and readily available hardware and there is nothing really exotic or difficult about the Rogers engine that a person couldn’t get from a valve supplier or get a metal fabrication company to construct.

However, while Leroy did state that his design was self-sustaining when going over 30 miles per hour, a key design feature is his very high performance compressor unit which he later patented as shown below. Present day vehicle engines are under-gearred and run at fairly low revs. These same engines operate much more efficiently at higher revs, if they are given different gearing. With the Rogers motor, the air contained in the high-pressure tank is sufficient to drive the pistons up and down. Air can be pumped back into the high-pressure tank by a compressor which has a much higher gearing and much lower capacity per piston stroke. The expanded air exiting from the engine is at much lower temperature than the surrounding air and if it captured in a buffer tank and used as the input of the compressor, then recharging the air tank is more efficient, provided that the tank absorbs heat from the surrounding environment, raising it’s temperature inside the tank and so giving an extra boost to the tank pressure, over and above the compression provided by the compressor.

One really nice feature of Leroy’s design is that he envisages it as being an adaption of an ordinary vehicle engine and he provides a considerable amount of practical detail as to how the adaption can be carried out.

Using a RotoVerter (as described in Chapter 2) to drive a compressor would lower the power requirements of the compressor drive to the extent that a motor adaption of this kind should be self-sustaining. The RotoVerter provides a major energy gain in its own right and is particularly suited to driving mechanical loads such as the compressor and it particularly ‘likes’ constant-load applications such as a compressor.

The adapted engine shown in the patent is like this:

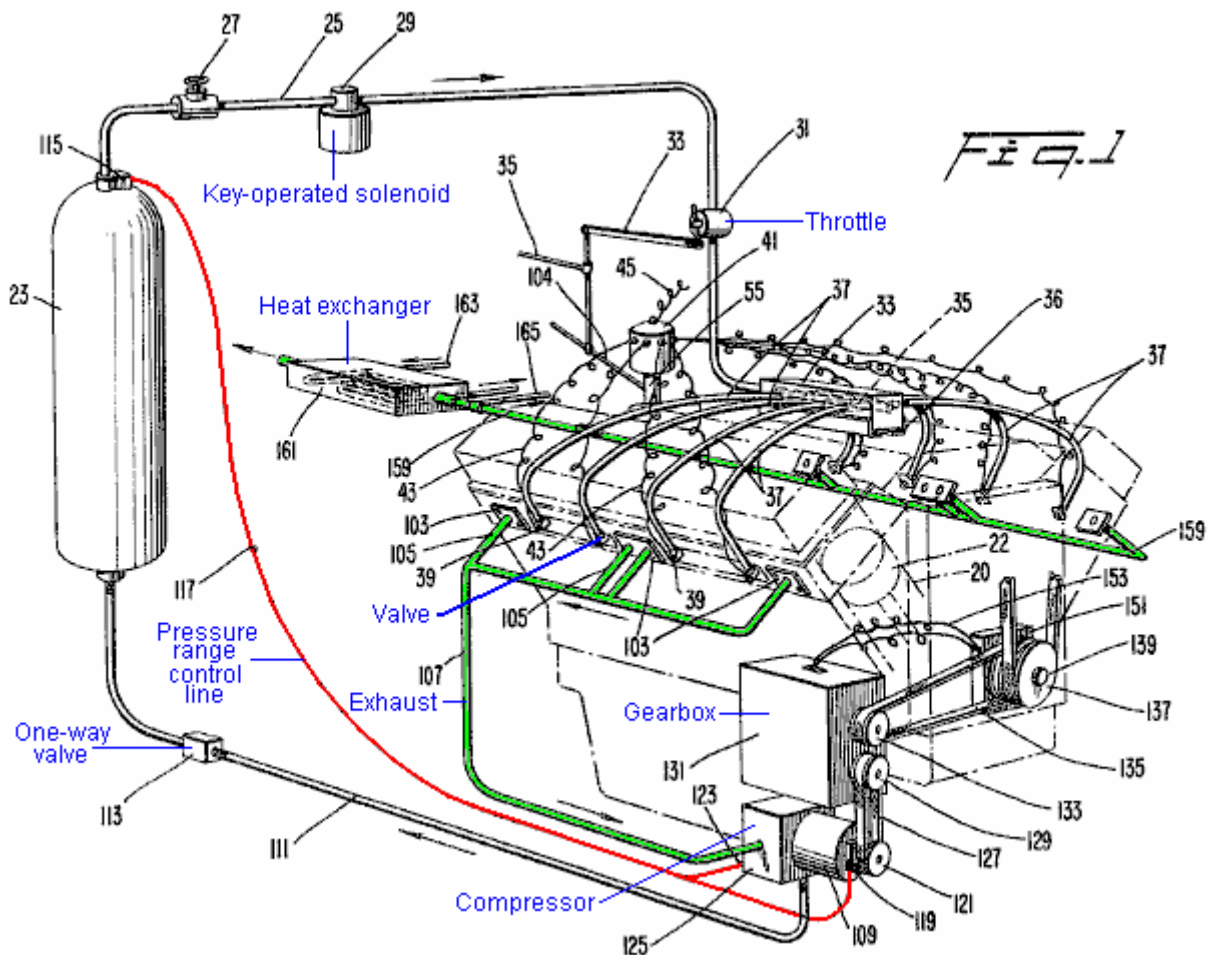

This patent shows how the practical details of running an engine on compressed air can be dealt with. What it does not show is background details of the actual energy flows and the effects of compressing air and then letting it expand. These things are not normally encountered in our daily lives and so we do not have an immediate intuitive feel for how systems like these will operate. Take the effects of expansion. While it is quite well known that letting a compressed gas expand causes cooling, the practical effect is seldom realised.

Leroy's compressor patent is shown here:

United States Patent 4,693,669 Supercharger for automobile engines

Inventor: Rogers Sr., Leroy K. (Rte. 13, P.O. Box 815-DD, Briarcliff Rd., Fort Myers, FL, 33908)

Publication Date: 15th September 1987

Abstract:

A supercharger for delivering supercharged air to an engine, comprising a shrouded axial compressor, a radial compressor which is located downstream of the axial compressor and a housing. The housing is comprised of four sections, including a section which is a highly converging, 'frustoconical' transition duct which favourably directs the discharge of the axial compressor to the inlet of the radial compressor and a hollow, highly convergent, exhaust cone section immediately downstream of the radial compressor which converges into the exhaust port of the supercharger. An annular flow deflector is provided for directing the discharge of the radial compressor into the exhaust cone.

Description:

Superchargers impart additional pressure to the air or the air/fuel mixture of an engine so that the cylinders receive a greater weight per unit volume of air or air/fuel mixture than would otherwise be supplied. As a result, the volumetric efficiency and power output of the engine are improved.

According to prior practices, superchargers generally comprise a single air-blower which forces air or an air/fuel mixture into the cylinders of an engine. Typically, the air-blower is driven by a gear train which is connected to the crankshaft of the engine with a gear ratio of about 6 to 1. These prior types of superchargers have been used extensively in racing engines and radial aircraft engines. However, by reason of their high operating speeds and their gear trains, these superchargers have been considered too complicated, too heavy and too costly for use with mass production engines such as are found in cars and trucks.

Recently, some car manufacturers have been offering turbocharged engines which expand to exhaust gases of the engine through a turbine to drive a centrifugal compressor. Although turbochargers are advantageous in that the turbine can deliver large amounts of power to the compressor, their extreme operating speeds require special bearings, lubrication and maintenance. In addition, turbochargers require special ducting, such as by-pass arrangements, which only add to their cost and maintenance requirements. Consequently, turbochargers are only offered as expensive options in cars.

Further, there is current interest in a new type of car engine which operates from tanks of compressed gas to effect reciprocation of its pistons. An example of such an engine can be found in the U.S. Pat. No. 4,292,804 issued to the same inventor of the present invention. In the referenced patent, at least a portion of the partially expanded exhaust gas from the cylinders is directed to a compressor where it is recompressed and then returned to the storage tanks from whence it originally came. It would be desirable that at least some, if not all of the aforementioned recompression of the exhaust gas could be achieved with a belt-driven, rotary supercharger that is easily manufactured and maintained, yet is capable of providing ample recompression.

Objects of the Invention:

Accordingly, an object of the present invention is to provide a supercharger suitable for improving the performance of engines of cars, helicopters or the like, which supercharger is inexpensive to produce and easy to maintain.

It is another object of the present invention to provide a supercharger which provides sufficient boost without resort to extreme operating speeds and accordingly avoids the costly complications associated with high speed operation.

It is yet another object of the present invention to provide a relatively compact and lightweight supercharger which is inexpensive to manufacture and maintain.

Another object of the present invention is to provide a belt-driven supercharger having a design which provides supercharging compression at relatively low operating speeds.

It is still another object of the present invention to provide a supercharger which can be quite readily disassembled and reassembled for purposes of low cost maintenance and repair.

Still another object of the present invention is to provide a supercharger which can be constructed from mass producible parts to thereby reduce the cost of its manufacture.

It is still another object of the present invention to provide a belt-driven supercharger which provides supercharging compression without resort to a larger number of compressor stages.

Yet another object of the present invention is to provide a rotary supercharger for a gas operated engine, which supercharger is easily manufactured and maintained, yet capable of providing ample recompression of the recirculating drive fluid.

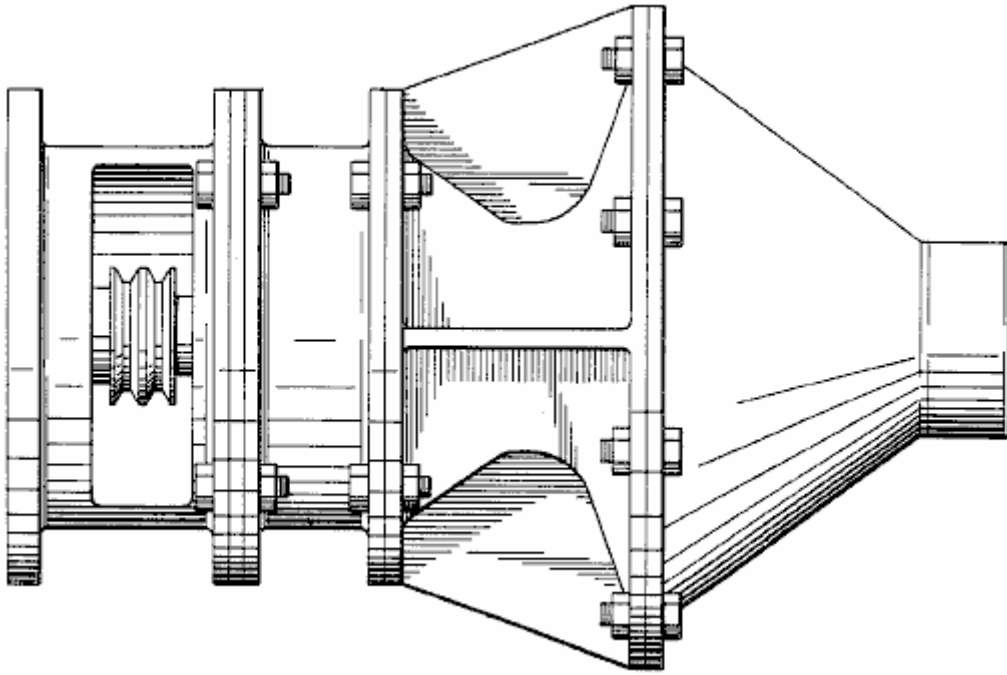

Summary of the Invention:

These and other objects are achieved by the present invention which provides a supercharger comprising a housing having an inlet and an outlet, a shrouded axial compressor and a radial compressor rotatably mounted within the housing, a highly convergent shallow, frustoconical transition duct for favourably directing the discharge of the axial compressor to the inlet of the radial compressor.

In accordance with a further aspect of the invention, the above-described supercharger further comprises an exhaust cone at a location downstream of the radial compressor and a flow deflector for directing the discharge of the radial compressor to the exhaust cone.

In the preferred embodiment, the housing itself comprises four sections: a cylindrical front housing section which defines an axially directed inlet; a second, cylindrical ducting section enclosing the axial compressor; a rear housing section defining the transition duct as well as the inlet and casing for the radial compressor; and the exhaust cone section which defines at its terminus the outlet of the housing. For driving the compressor shaft, a double-tracked pulley wheel is secured to the forward end of the common shaft, which pulley wheel is adapted to receive one or more drive belts from the crank-shaft wheel of the engine. A lateral opening in the front housing section accommodates the connection with the drive belts.

With the disclosed arrangement, compression can be achieved for supercharging purposes without resort to a large number of compressor stages or high operating speeds. Additionally, the design of the disclosed supercharger avoids the need for guide vanes between the axial compressor and the radial compressor. The exhaust cone section also favourably avoids the build-up of back pressure against the radial compressor. The design is also very simple and therefore inexpensive to manufacture and maintain.

Other objects, advantages and novel features of the present invention will become apparent from the following detailed description of the invention when considered in conjunction with the accompanying drawing.

Brief description of the Drawings:

A preferred embodiment of the present invention is described in greater detail with reference to the accompanying drawing wherein like elements bear like reference numerals, and where:

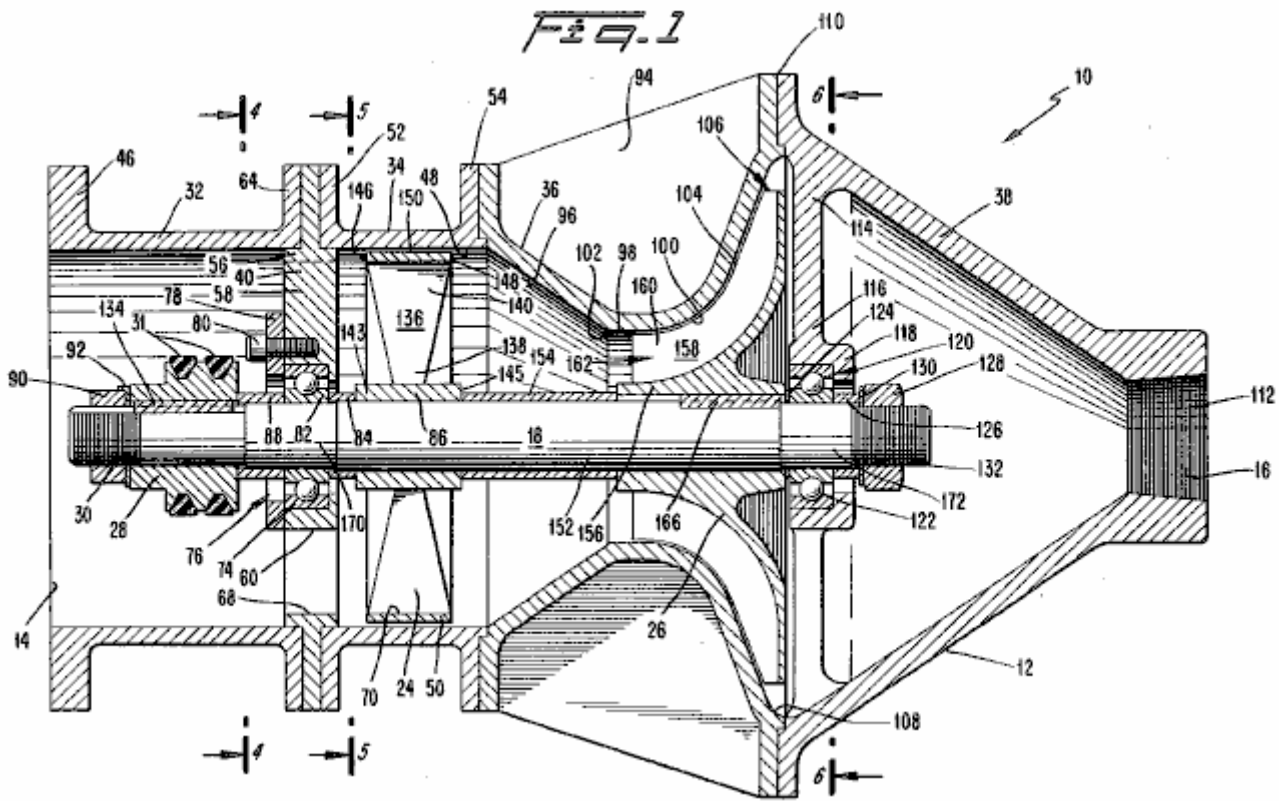

Fig.1 is a cross-sectional side view of a supercharger constructed in accordance with the preferred embodiment of the present invention;

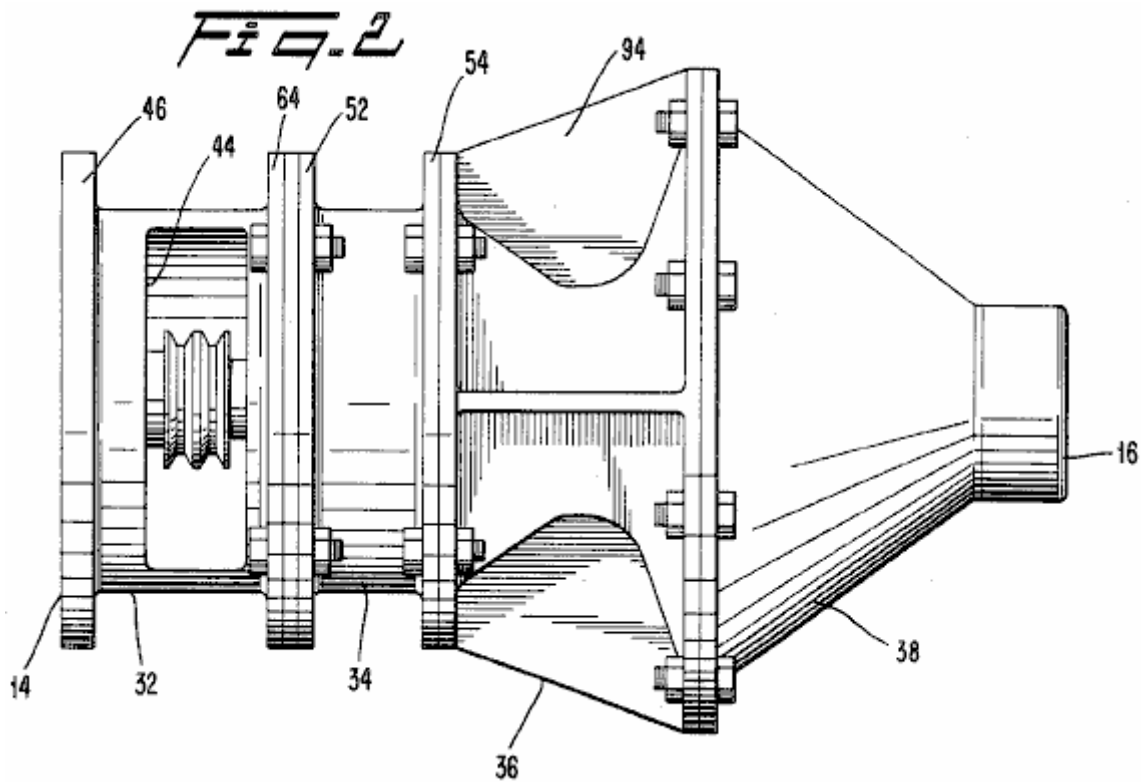

Fig.2 is a side view of the supercharger of Fig.1;

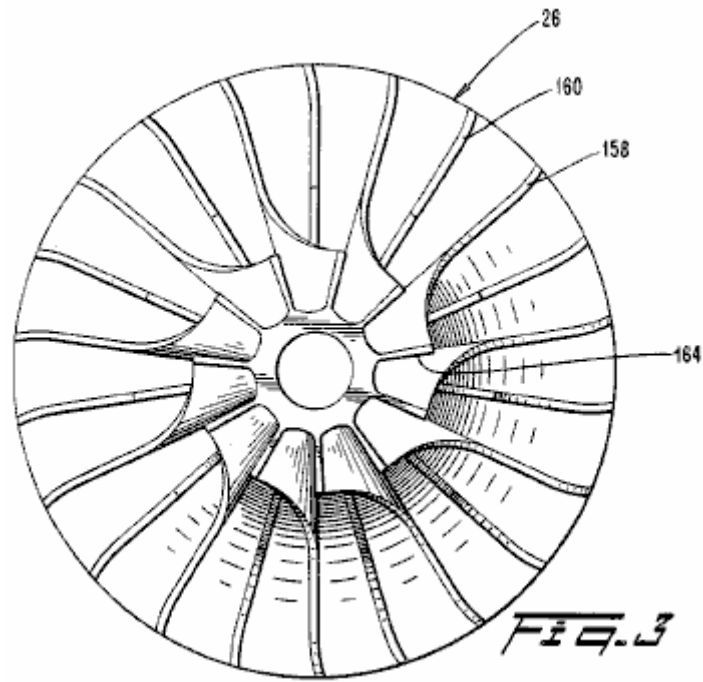

Fig.3 is a frontal view of the impeller of the supercharger of Fig.1;

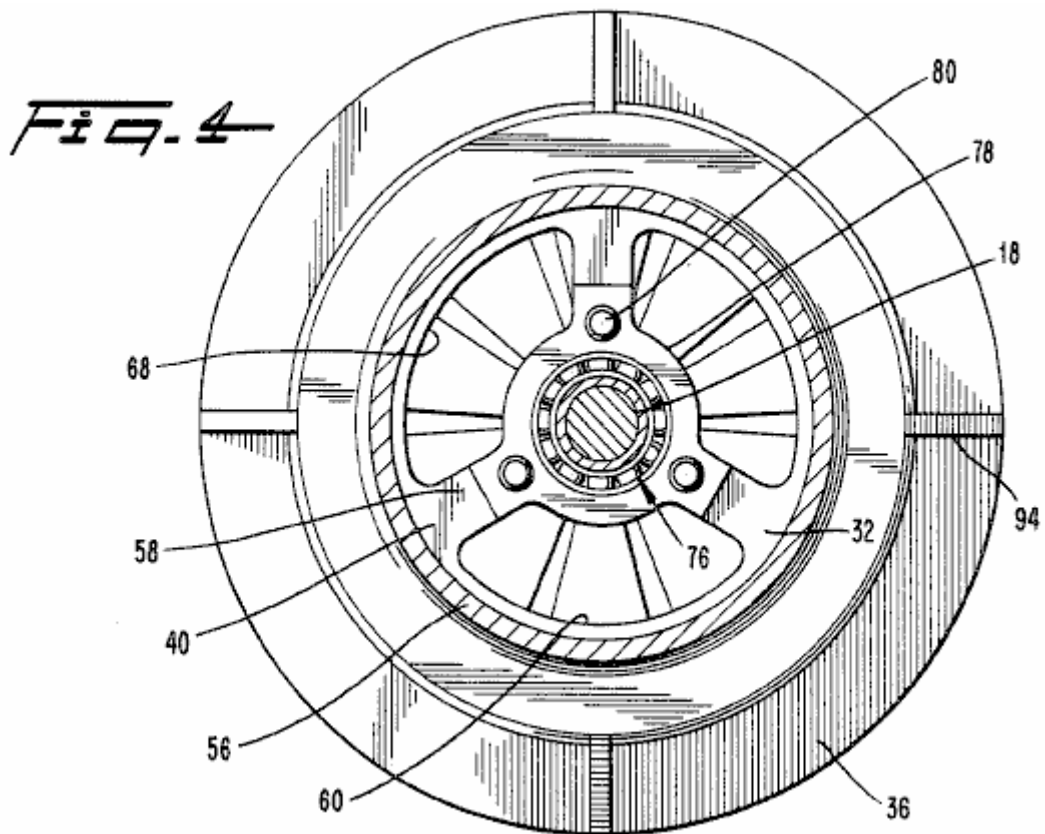

Fig.4 is a cross-sectional view taken along line 4--4 of Fig.1;

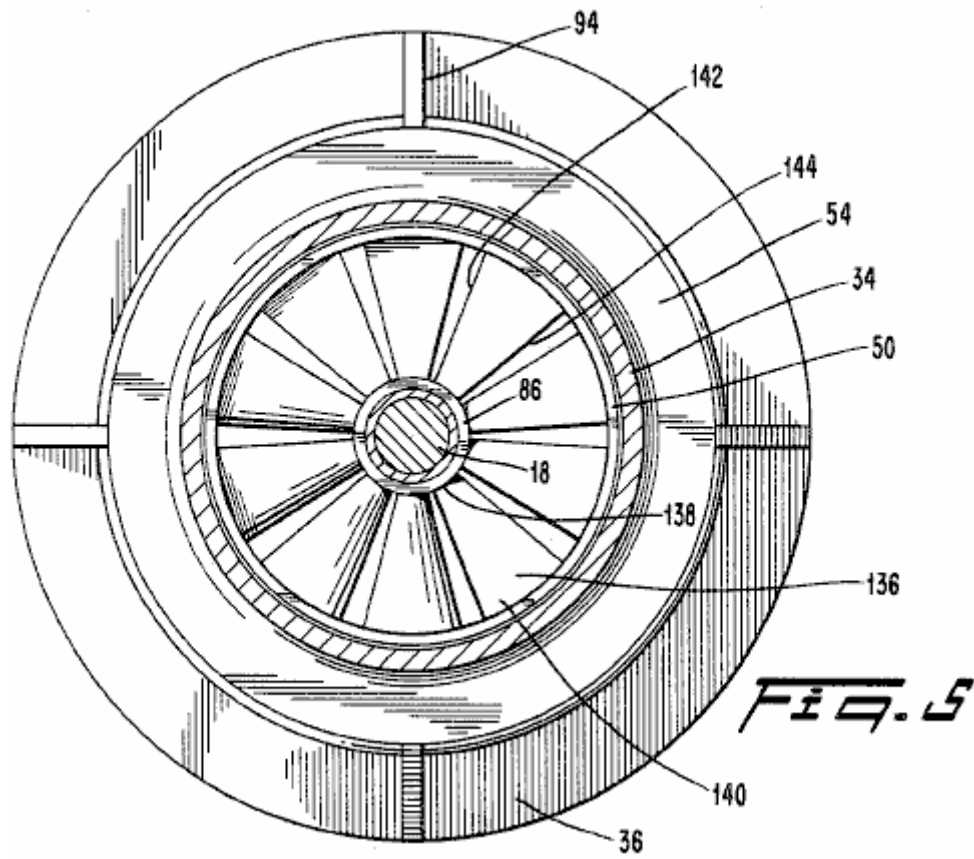

Fig.5 is a cross-sectional view taken along line 5--5 in Fig.1;

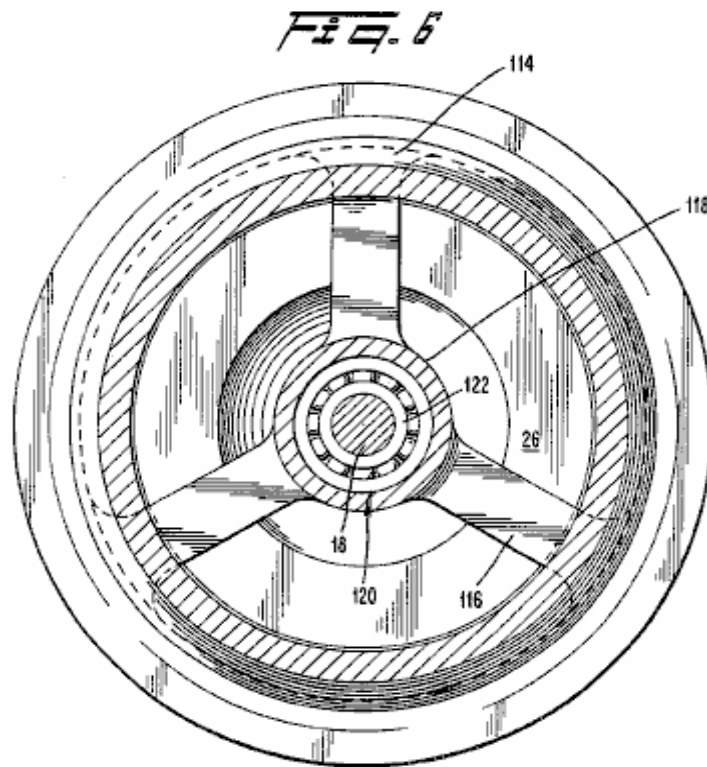

Fig.6 is a cross-sectional view taken along line 6--6 in Fig.1;

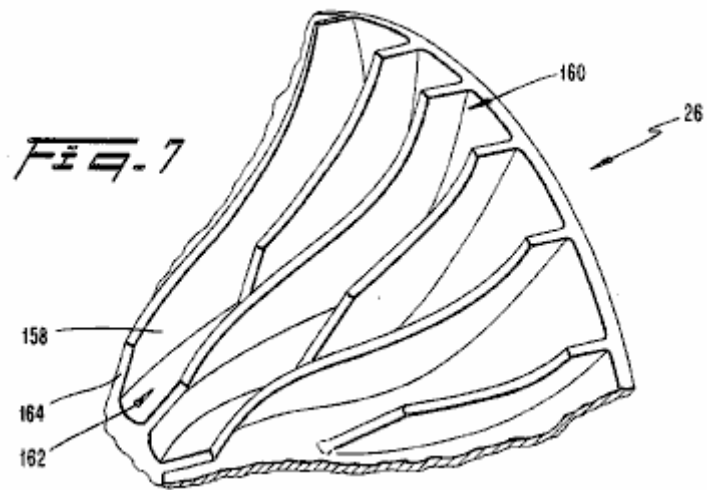

Fig.7 is a perspective view of a segment of the impeller of the supercharger of Fig.1; and

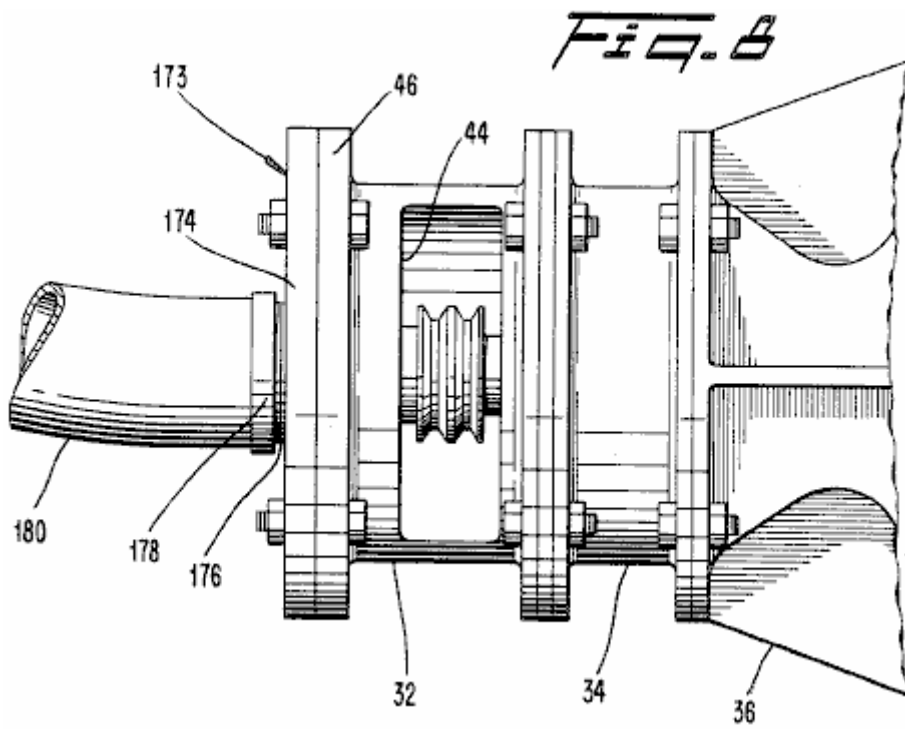
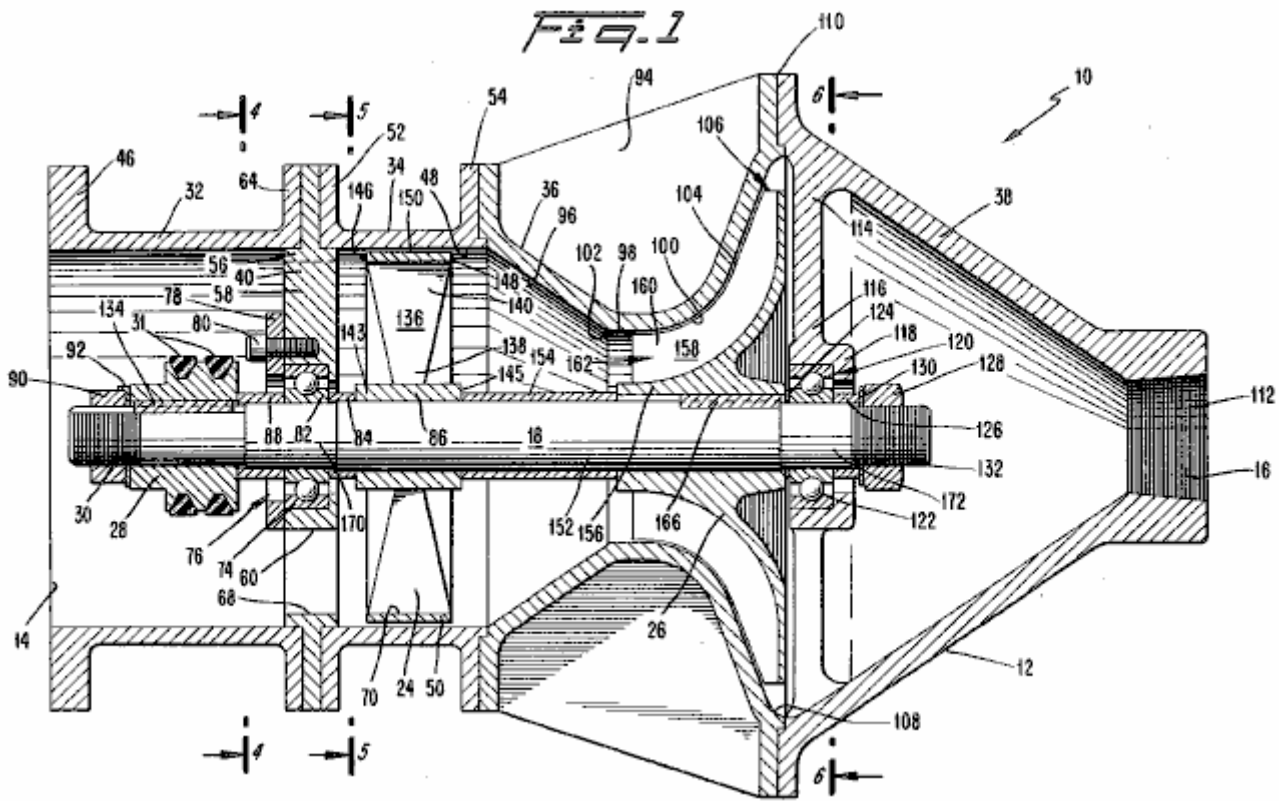

Fig.8 is a partial side view of the supercharger of Fig.1 with an adaptor .

Detailed Description of the Preferred Embodiment:



Referring to **Fig.1** and **Fig.2**, a supercharger **10** is provided for supplying supercharged air to a car engine or the like, so that the engine receives a greater weight per unit volume of air or a fuel/air mixture than would be otherwise supplied. In accordance with a preferred embodiment of the present invention, the supercharger **10** comprises a housing **12** having an axially directed inlet **14** for receiving ambient air and an axially directed outlet **16** for delivering supercharged air to the intake of the car engine. Rotatably mounted within the housing **12** is a shaft **18** on which are secured an axial compressor **24** and a radial compressor **26**, which is positioned downstream of the axial compressor. A pulley wheel **28** is secured to a forward end **30** of the shaft for receiving drive belts **31**, which drive belts connect the shaft **18** to a pulley wheel on the crankshaft of the engine (not shown). The drive belts **31** deliver torque to the shaft **18** as required for driving the compressors **24** and **26** of the supercharger **10**.

Housing **12** is constructed from four sections which are preferably bolted together at flanged connections in an end-to-end relationship. These sections include a front housing section **32**, an axial compressor duct section **34**, a rear housing section **36** and an exhaust cone section **38**. The shaft **18** extends along the longitudinal axis of the housing **12**.

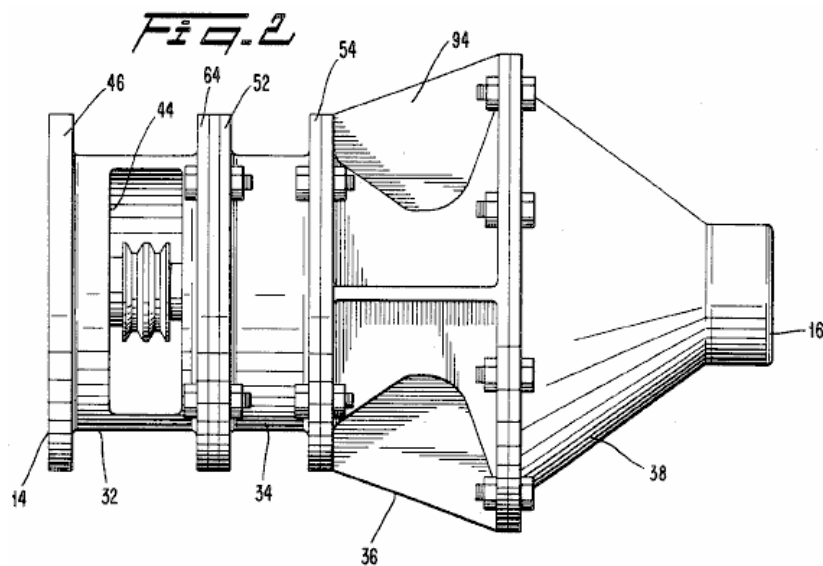

The front housing section **32** is a hollow cylinder which extends forward of a front bearing support **40**. The front housing section **32** encloses the forward end **30** of the shaft **18** and the associated pulley wheel **28**. At its forward end, the front housing section **32** defines the inlet **14** for receiving air from an external source (not shown).

Referring particularly to **Fig.2**, the front housing section **32** includes a lateral opening **44** on one side in order to accommodate the connection of the drive belts **31** to the pulley wheel **28**. The front housing section **32** also includes a forward flange **46** for accommodating the connection of air filters, carburetors, air scoops or the like upstream of the supercharger **10** according to the particular engine layout.

It is to be understood that in the usual engine layout, the supercharger **10** receives air or a fuel/air mixture from an external source through its inlet **14**, compresses the air or fuel/air mixture and then delivers it to the intake of the engine.

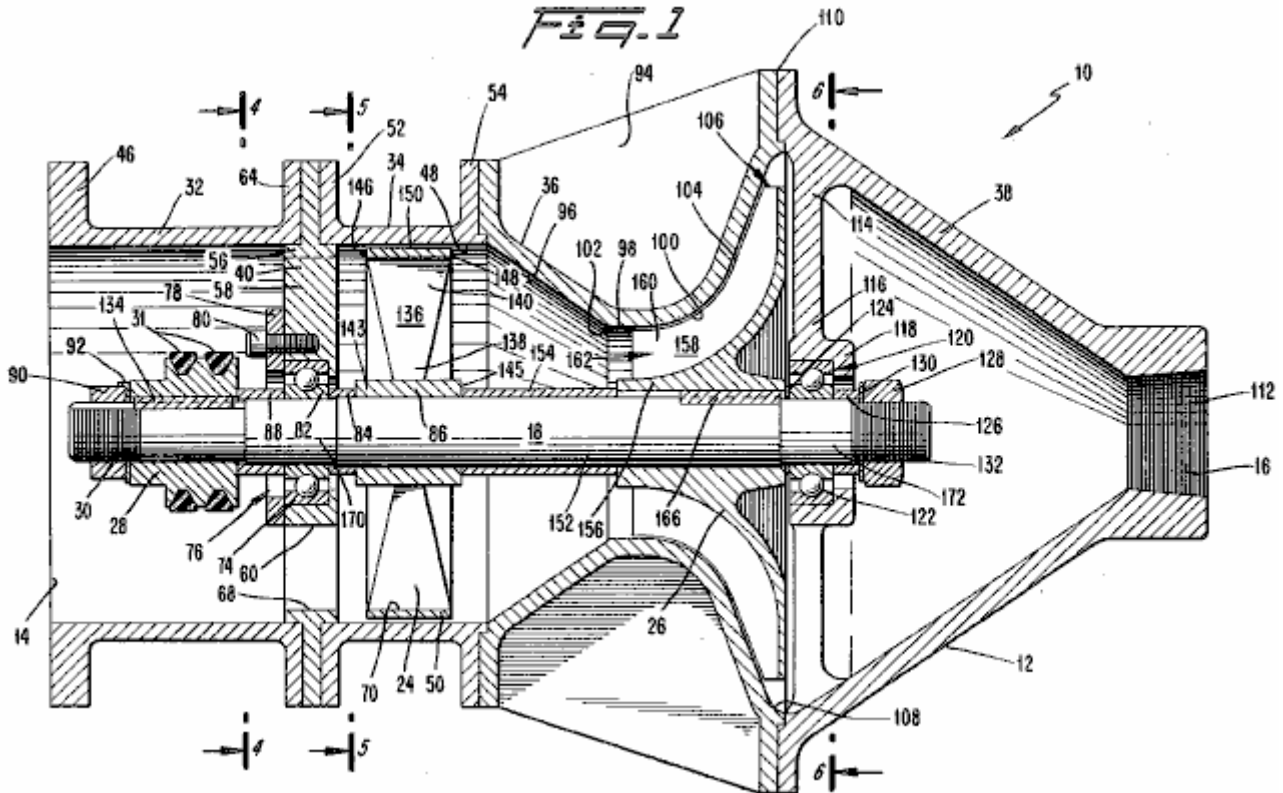

Referring again to **Fig.1**, the pulley wheel **28** is interference-fitted upon the forward end **30** of shaft **18** and a key **134** is used to lock the pulley wheel **28** in place. The pulley wheel **28** is preferably a double-track design which is suitable for the attachment of twin drive belts, although a single-belt type pulley wheel would be adequate. The pulley wheel **28** is preferably sized so that the ratio of its diameter with respect to the diameter of the drive wheel of the engine's crankshaft provides an effective gearing ratio in the range of approximately two and one-half to four and one-half. Thus at idle, when the car engine is running at approximately 700 rpm, the supercharger **10** is running at approximately 2,400 rpm, and at cruise, when the engine is running around 2,500 rpm, the supercharger **10** is preferably turning over in the range of 6,000 to 8,000 rpm. It is to be noted that although the diameter of the pulley wheel **28** may be substantially reduced in order to achieve a desired gearing ratio, the double-track wheel **28** presents a sufficient sum total of surface area to avoid slippage of the belts **31**.

The next adjacent section of housing **12** is the axial compressor duct **34** which is a short cylinder coaxially disposed about the axial compressor **24**. Preferably, the axial compressor duct **34** is constructed from cast aluminium, with the interior surfaces **48** machined to assure uniform clearance between the duct **34** and shroud **50** of the axial compressor **24**. As with other sections of the housing **12**, the axial compressor duct **34** is provided with flanges **52** and **54** for effecting connection to the adjacent housing sections. The axial compressor duct **34** guides air delivered from the front housing section **32** towards the axial compressor **24**.

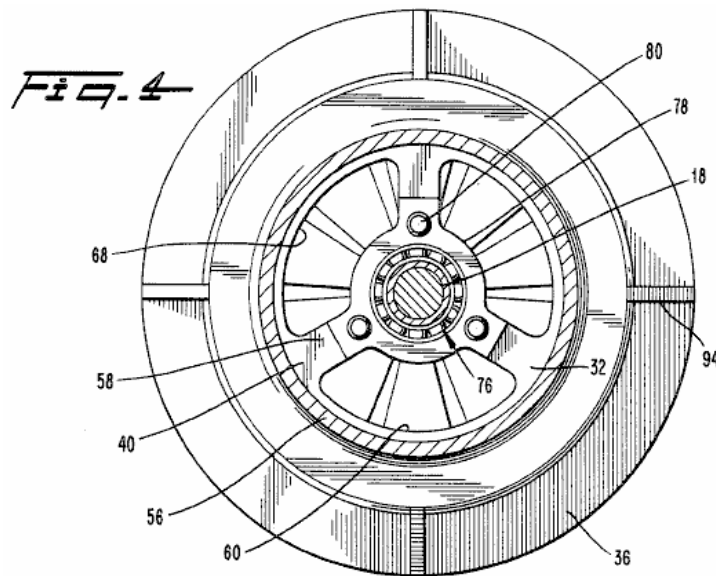

Referring now to **Fig.1** and **Fig.4**, a front bearing support **40** is placed between the front housing section **32** and the axial compressor duct **34**. The front bearing support **40** includes an outer annulus **56** and three radial arms **58**. Between these arms are defined passages **60** for allowing air to pass through the bearing support **40**. The outer annulus **54** is secured by bolts connecting a rear flange **64** of the front housing section **32** and the flange **52** of the axial compressor duct **34**. By this arrangement, the front bearing support **40** is rigidly secured to the housing **12** so that loads and shocks to the shaft **18** can be transferred through the front bearing support **40** to the housing **12**.

In the preferred embodiment, the outer annulus **56** of the bearing support **40** extends into the region of the inlet **14** of the front housing section **32** in such a way that its inner rim **68** coincides with the inner rim **70** of the shroud **50** of the axial compressor **24**. In this way, the outer annulus **56** contributes to the guiding of the flow of air toward the axial compressor **24**.

An outer raceway **74** of the front roller bearing assembly **76** is secured between the front bearing support **40** and a bearing retainer plate **78**, which is secured by the removable bolts **80**. In this preferred embodiment, the front bearing assembly **76** is of the sealed, high speed type. A suitable commercially available bearing assembly is marketed under the reference: model Fafnir 405KDD. Preferably, a lower raceway **82** of the front bearing assembly **76** is secured to the shaft **18** with an interference fit. A spacer **84** is provided on one side of the lower raceway **82**, which spacer **84** also abuts a hub **86** of the axial compressor **24** in order to position the axial compressor **24** at a predetermined distance downstream of the bearing support **40**. Similarly, a spacer **88** is provided on the other side of the lower raceway **84**, and it abuts the pulley wheel **28** so as to space apart the pulley wheel **28** from the front bearing support **40** to ensure that there is sufficient clearance between them.

It should be appreciated that the bearing retainer plate **78** allows ready access to the front bearing assembly **76** for purposes of maintenance or repair. To service the front bearing assembly **76**, a nut **90** and lock-washer **92** on the forward end **30** of the shaft **18** are loosened and removed together with the pulley wheel **28** and the spacer **88**. Then bolts **42** and the bearing retainer plate **76** are removed, leaving the whole bearing assembly **76** exposed for servicing and/or removal.

The rear housing section **36** is connected by bolts to the downstream end of the axial compressor duct **34**. Preferably, the rear housing section **36** is constructed from a single section of cast aluminium and includes external longitudinal ribs **94** for enhancing the structural rigidity of the rear housing section **34**. The walls of the rear housing section **36** define three elements of the supercharger **10**: a highly conical transition duct **96** which favourably directs the output of the axial compressor to an inlet **98** of the radial compressor **26**; the inlet **98** of the radial compressor **26**, itself; and a casing **100** for the radial compressor **26**.

The transition duct **96** is a hollow, frustoconical portion having a half-apex angle (from the generatrix to the axis of symmetry) of approximately 35°. The angle is selected such that the inlet to the radial compressor **26** is as close as possible to the outlet of the axial compressor, without causing undue back-pressure. In the preferred embodiment, the transition duct **96** begins a short distance downstream of the axial compressor **24** and ends at the beginning of the inlet **98** of the radial compressor **26**. The highly conical shape of the

transition duct **96** is believed to roll-in the higher volume of air being discharged from the more radially outward portions of the axial compressor **24**. This rolling-in action is believed to promote a favourable flow regime at the inlet **98** of the radial compressor **26** so that there is no need for inlet guide vanes for the radial compressor **26**. It is also believed that the highly conical shape of the transition duct **96** affects upstream flow conditions at the axial compressor **24** in such a way that its performance is improved. It has also been found that there is no need for a stator (or exit guide vane) for the axial compressor **24**.

In essence, it is believed that the transition duct **96** performs the functions of the exit vanes of axial compressors and inlet guide vanes of radial compressors, but without the pressure losses commonly associated with them. Avoiding these pressure losses and the expected improvement in the performance of the axial compressor, allows the supercharger **10** to impart a higher overall pressure ratio than would otherwise be achieved without the transition duct **96**. As a result, adequate compression is achieved at moderate operating speeds without resort to a bank of several axial compressors. It should be understood however, that when connecting the supercharger **10** to a relatively slowly reciprocating diesel or a very large engine, it may be desirable to include two or more axial compressors in order to boost the supercharger's overall pressure ratio. In such cases, the present invention would then include the placement of a transition duct downstream of at least the last axial compressor.

At the inlet **98** of the radial compressor **26**, the walls of the rear housing **36** are cylindrical and coaxially positioned around shaft **18**. It should be noted that in the preferred embodiment, the surface transition **102** from the transition duct **96** to the inlet **98** is rounded-off.

The casing portion **100** of the rear housing section **36** closely follows the contour defined by blade edges **104** of the radial compressor **26** in a close, substantially sealing manner as is well known in the art of radial compressors. The casing portion **100** of the rear housing section **78** channels air between the rotating blades of the radial compressor **26** so that the blades can impart work to the passing air. The casing portion **100** also defines a discharge outlet **106** for the radial compressor **26**.

Just beyond the discharge outlet **106** of the radial compressor **26**, the interior surfaces of the rear housing section **36** begin to curve immediately inwardly to provide a transition into the next adjacent section of the housing **12**, the exhaust cone **38**. In this fashion, the interior surfaces at the rear-most portion of rear housing section **36** and those of the forward portion of the exhaust cone **92** define internally a flow deflector **108**. In the preferred embodiment, the flow deflector **108** is closely and concentrically positioned around outlet **106** of the radial compressor **26** so that the air being discharged from the radial compressor **26** does not have the opportunity to diffuse significantly prior to its arrival at the annular flow deflector **108**. The annular flow deflector **108** directs the output of the radial compressor **26** into the exhaust cone **38** by providing a smooth surface transition from the interior of rear housing section **36** to the interior of the exhaust cone **38**.

The exhaust cone **38** is a highly convergent, hollow, conical section placed immediately downstream of the radial compressor **26** for receiving the output of the radial compressor **26** from the annular flow deflector **108**. In the preferred embodiment, the exhaust cone **38** is a single section of cast aluminium which is joined to the downstream end of the rear housing section **36** at a flanged joint **110**. Preferably, the exhaust cone **92** converges according to a half-apex angle of approximately 35° and defines the exhaust port **16** at its terminus. A threaded section **112** at the exhaust port **16** allows the attachment of the appropriate external ducting (not shown) leading to the intake of the engine.

During operation of the supercharger **10**, the space enclosed by the exhaust cone **92** prevents the build up of an elevated back pressure which might otherwise arise and detract from the operation and efficiency of the radial compressor **26**. The enclosed space of the exhaust cone **92** is also of sufficient volume to absorb pulses and to average out unsteady flow conditions so to promote a smooth and continuous output from the supercharger **10**.

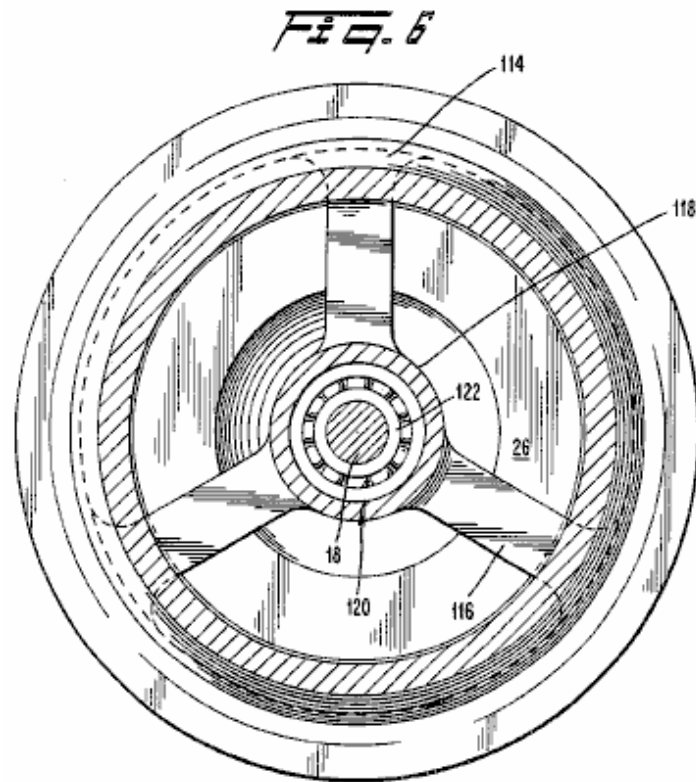

Referring now to **Fig.1** and **Fig.6**, the exhaust cone **38** includes a rear bearing support **114** which comprises members **116** which extend radially inwardly from the outer walls of the exhaust cone **38**. At a radial inward location close to the shaft **18**, the members **116** converge to form a cupped annulus which serves as a housing **118** for the rear bearing assembly **120**. The housing **118** is open towards the rear face of the radial compressor **24** to facilitate disassembly of the supercharger **10**. The rear bearing assembly **120** is the same type and size as the front bearing assembly **76**. The inner race **122** of the bearing assembly **120** is set in place on the shaft **18** by spacers **124** and **126** in conjunction with a nut **128** and washer **130** on the rearward end **132** of the shaft **18**. In this preferred embodiment, the members **116** are formed to be integral with the walls of the exhaust cone **38**.

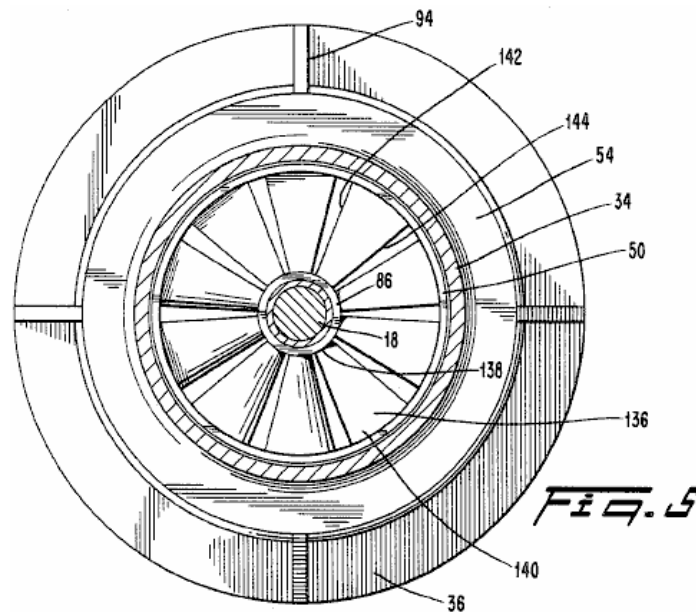

Referring to **Fig.1** and **Fig.5**, upon rotation, the axial compressor **24** draws air through the inlet **14** and imparts an initial amount compression to the air as it forces the air into the transition duct **96** of the rear housing section **36**. In the preferred embodiment, the axial compressor **24** comprises a hub **86**, the shroud **50** and a series of ten (10) equally spaced, radial blades **136**. Ideally, each blade **136** increases in cord from a root **138** to a tip **140** and includes a trailing edge **142** and a leading edge **144**, where these edges are both

slightly curved. The blades gradually increase in pitch from approximately 12° at the root 138 to approximately 36° at the tips 140. However, the particular values of pitch and other geometrical aspects of the blades 136 might be varied in accordance with different operating speeds or other parameters as would be apparent to one skilled in the pertinent art and familiar with this disclosure.

The axial compressor 24 is preferably constructed from a single, cast aluminium section with the faces 143 and 145 of the hub 86 being machined for purposes of achieving accurate, axial positioning of the axial compressor 24 on the shaft 18 relative to the housing 12. The faces 146 and 148 of the shroud 72 are also machined flat. Additionally, the outer periphery 150 of the shroud is machined to assure uniform clearance between the shroud and the adjacent interior surfaces 48 of the axial compressor duct 34. Preferably, the axial compressor 24 is secured to the shaft 18 by an interference-fit on to a stepped portion 152 of the shaft 18. The spacers 84 and 154 axially position the axial compressor 24 relative to the front bearing support 40 and the radial compressor 26, respectively.

Dynamic balance test machines of the conventional type may be used to test the balance of the axial compressor 24 prior to its installation. If an imbalance is detected, material can be removed at the outer periphery 150 of the shroud 50 so as to achieve proper balance.

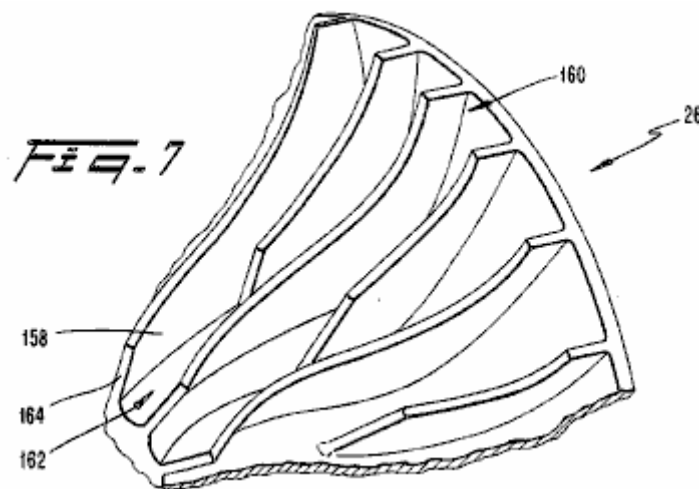

Referring now to Fig.1, Fig.3, and Fig.7, the radial compressor 26 is constructed from a single section of cast aluminium and includes a hub 156 and curved blades 158. Interposed between each pair of blades 158 are a second set of blades 160 which terminate short of the intake 162 of the radial compressor 26 so that the intake 162 is not crowded by both sets of blades. Accordingly, the radial compressor 26 features both a large total number of blades and an intake of relatively small diameter, and these features enhance the performance of the compressor 26. In the region of the intake 162, the blades 158 present leading edges 164 and undergo a twist into the direction of rotation so as to prevent a favourable angle of attack at the intake 162.

Preferably, the radial compressor 26 is positioned upon the stepped section 128 of the shaft 18 with an interference-fit and locked against rotational slippage by a key 166. The spacer 124 assures clearance between the rear face of the radial compressor 26 and the rear bearing assembly 120.

The shaft 18 is constructed from a hardened steel and is threaded at both ends 30 and 132 to receive nuts 90 and 128, respectively. In addition to the central stepped portion 152, which receives the compressors 24 and 26, the shaft 18 also features stepped portions 170 and 172 for receiving the front and rear bearing assemblies 76 and 120, respectively. The stepped arrangement of the shaft 18 facilitates assembly and disassembly in that the stepped portion 152 of the greatest diameter is centrally located on the shaft 18 and all the stepped portions are greater than the diameter of the threading at ends 30 and 132.

Please note that the bearing supports 40 and 114 are in a fixed position relative to the housing 12 and that the compressors 24 and 26 are held in position between the bearing supports 22 and 40 by spacers 84, 124 and 154, which have predetermined lengths. Consequently, the placement of the compressors 24 and 26 relative to the longitudinal axis of the housing 12 is fixed by the spacers and not by the axial location of the shaft 18 relative to the housing 12. Please also note that the stepped portions 152, 170 and 172 of the shaft 18 are each provided with extra lengths so that the respective components (the bearing assemblies and compressors) can each be situated over a relatively wide range of locations in the respective stepped

portions. Thus, the shaft **18** need not be positioned accurately along the longitudinal axis of the housing **12** in order to achieve proper assembly of the supercharger **10**. For instance, if nuts **90** and **128** had been tightened differently than they appear in **Fig.1**, then shaft **18** might have been displaced slightly in the axial direction from where it is shown in **Fig.1**. However, the relative positioning of the various components on the shaft **18**, i.e., the pulley wheel **28**, the compressors **24** and **26** and the bearing assemblies **76** and **120**, would have remained the same relative to themselves and the housing **12**. This feature eases the process of manufacture and accordingly, reduces costs. It also reduces the amount of labour required for reassembly after repair.

In operation, the supercharger **10** is suitably connected at its outlet **16** to an intake of a car engine, with the drive belts **31** from the crankshaft of the engine being attached to the pulley wheel **28** of the supercharger **10**. Then, as the engine is operated, torque is transferred by the drive belts **31** to the pulley wheel **28** for driving the compressors **24** and **26**. Upon rotation, the axial compressor **24** draws air through the inlet **14**, imparts an initial amount of compression to the air and discharges it into the transition duct **96** with a swirl. By reason of its design, the axial compressor **24** is believed to move a greater volume of air in the region of its blade tips **140** than at its more radially inward locations. Accordingly, there is a greater mass of air situated at the outer annular region behind the axial compressor **24** than at the inner annular region. As the discharge from the axial compressor **24** is caused to leave the axial compressor duct **34**, the highly convergent, transition duct **96** is believed to cause the outer annulus of air which is discharged from the axial compressor **24** to roll-in. This action is believed to have two favourable results. First, the roll-in action causes a flow regime to be established at the inlet **98** of the radial compressor **26** such that the need for a guide vane is wholly avoided. Secondly, and of equal importance, the rolling-in action, in conjunction with the large volume of space enclosed by the transition duct **96**, is believed to affect the performance of the axial compressor **24** favourably, so that a higher pressure ratio is obtained from it.

Since the overall pressure ratio of the supercharger **10** is the product of the pressure ratios of the two compressors, it can be seen that the increase in performance of the axial compressor **24** results in a corresponding improvement in overall performance of the supercharger. It should also be noted that the deletion of inlet guide vanes for the radial compressor **26** and of exit vanes for the axial compressor **24** greatly simplifies the design of the rear housing section **36** and therefore provides savings in costs of manufacture. It also avoids the pressure losses associated with such guide vanes, which are often quite significant.

Upon leaving the transition duct **96**, the pre-swirled flow of air enters the inlet **98** of the radial compressor **26** and then into the compressor **26** itself. In passing through the radial compressor **26**, the air is turned and whirled such that the airflow is centrifugally discharged with a substantial radial velocity component, whereupon the resultant flow is abruptly turned by the annular flow deflector **108** and caused to enter the exhaust cone **38**. As previously explained, the large volume of space enclosed by the exhaust cone **38** induces flow conditions behind the radial compressor **26** such that elevated back pressures are avoided, pressures which might otherwise impair the performance of the radial compressor **26**. Pulses in the output of the radial compressor **26** are also moderated. The air is then delivered in a compressed state to the exhaust port **16** of the exhaust cone **38**. The supercharged air then flows down the appropriate intake system of the engine until it reaches the cylinder or cylinders of the engine.

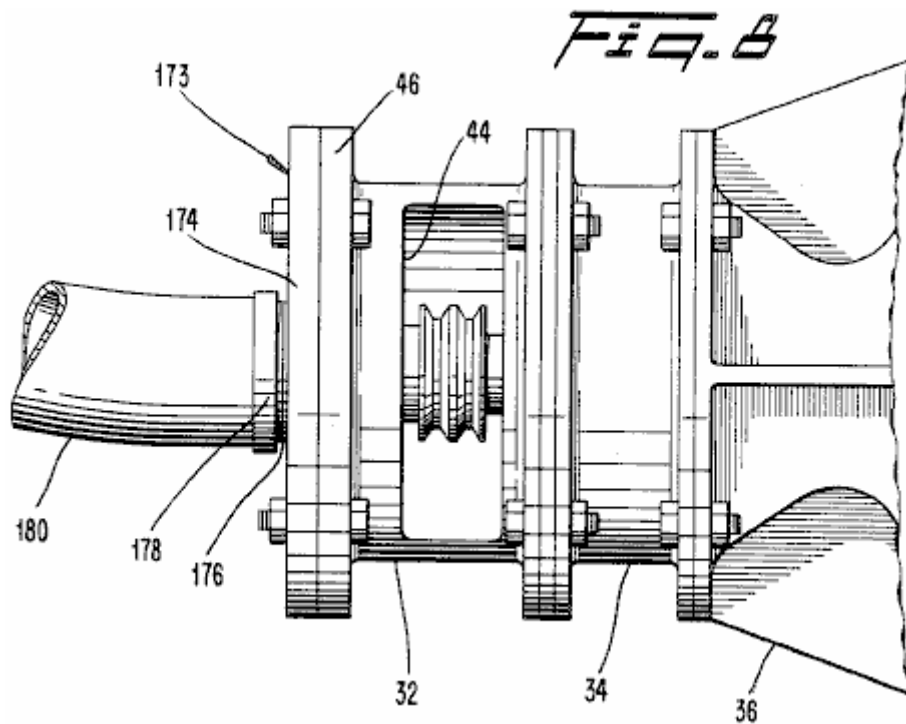

With respect to the application of the supercharger **10** to air-tank powered engines, such as disclosed in U.S. Pat. No. 4,292,804, the supercharger **10** functions in the same manner as described above, but is connected to the engine differently. In the air tank powered engine, at least one of the exhaust manifolds of the engines delivers partially expanded air to a line connected to the inlet **14** of the supercharger **10**. Referring to **Fig.8**, in most of such applications, this line will be of a smaller diameter than the housing **12** at the inlet **14** of the supercharger, such that an adaptor **173** is needed. The adaptor **173** comprises an annular plate **174** having a threaded aperture **176** sized to receive a mating, threaded end **178** of the line **180**. The plate **174** is secured to the flange **36** of the front housing section **32** by a plurality of bolts. Because the air coming from the line **180** is usually less than the full capacity of the supercharger, additional air is introduced through the lateral opening **44** along the side of the front housing section **32**. In this application, the opening **44** thus serves as an air intake port as well as a means for accommodating the drive belts **31** and must therefore be sized upon the additional criteria that it not be so large as to upset the flow of the incoming air in the line **180**. Upon the passage of the air through the supercharger, the air is directed through the exhaust port **16** and into a suitable line connected to it, which line may lead directly to the engine or to the storage tanks of the engine. If directed to the tanks, this recompressed air is used to supplement the required recharging of the storage tanks.

It is to be appreciated that savings in the cost of manufacturing the supercharger **10** are achieved by reason that the housing **12**, the bearing supports **40** and **114**, the axial compressor **24** and the radial compressor **26** are all constructed from cast aluminium parts and require only a minimum amount of machining. Moreover, the roller bearing assemblies **76** and **120** are commercially available components, and the supercharger **10** is easily assembled. These aspects further reduce the cost of manufacture and render the disclosed supercharger inexpensive to maintain and overhaul. More importantly, the supercharger **10**, despite its simple design, provides supercharging at relatively low operating speeds. With its lower operating speeds, the service life of the supercharger **10** is extended and the risk of it suffering mechanical failure is reduced. The need for special bearing designs and lubrication is also avoided. Accordingly, the supercharger **10** is highly suitable for mass production and for use in cars, trucks, helicopters or the like.

The Vortex Tube.

The web site <http://www.airtx.com/how-does-a-vortex-tube-work.htm> show "vortex tubes" which are completely passive devices with no moving parts:

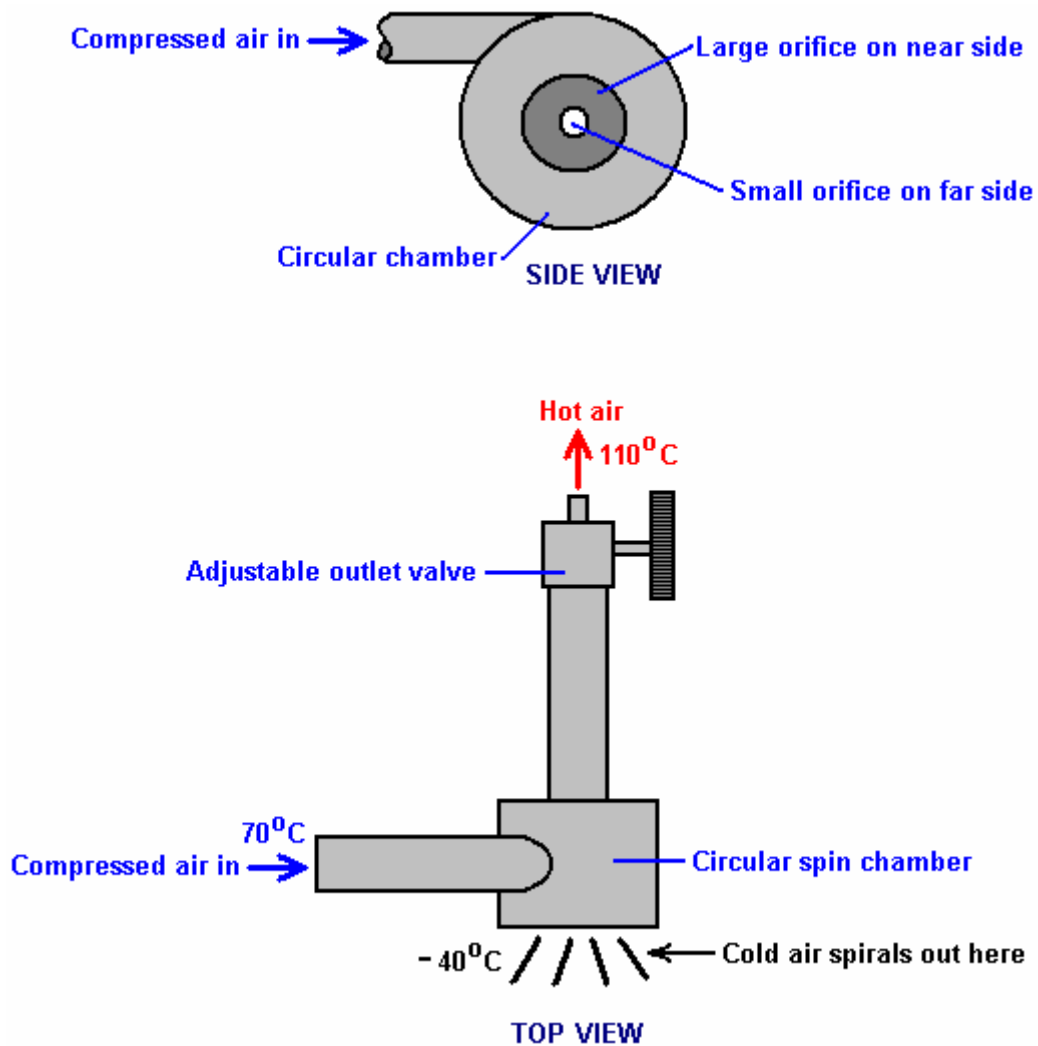

This device does things which you would not expect. Compressed air at a temperature of, say, seventy degrees Centigrade is fed into the circular chamber where the shape of the chamber causes it to spiral rapidly as it exits the tube:

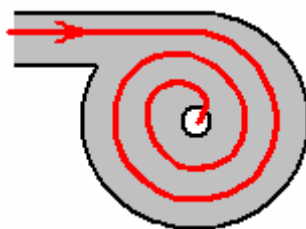

There is an energy gain in a vortex, as can be seen in a hurricane or tornado, but the really interesting thing here is the dramatic change in temperature caused by the change in pressure as the air expands. The ratio of heat gain to heat loss is controlled by the ratio of the sizes of the openings, which is why there is an adjustable nozzle on the small opening.

The air exiting through the large opening is much higher volume than the air exiting through the small opening and it expands very rapidly, producing a massive drop in temperature. The density of this cold air is now much higher than the air entering the vortex chamber. So there has been both a drop in temperature and an increase in density. These features of the expansion are made use of in the Leroy Rogers engine design, where some of the expanded air exhaust of the engine is compressed and passed back to the main air storage tank. While the compressor does raise the air temperature as it pumps the air back into the tank, it does not reach its original temperature instantly.

This results in the air temperature inside the tank dropping as the engine operates. But, the lowered tank temperature causes an inflow of heat from its immediate environment, raising the overall tank temperature again. This warming of the chilled air causes the tank pressure to increase further, giving an energy gain, courtesy of the local environment. It is important to understand that it takes less energy to compress air than the kinetic energy which can be generated by letting that compressed air expand again. This is a practical situation, courtesy of the local environment and is not a breach of the law of Conservation of Energy. It is also a feature which has not yet been exploited to any great degree and which is just waiting to be used by any adventurous inventor or experimenter.

Eber Van Valkenburg’s Engine.

Eber presents a custom engine based on these principles. His engine uses both compressed air and compressed oil to manipulate pressures within the system and provide an engine which is self-powered. In the Appendix is a slightly re-worded copy of the Eber Van Valkenburg patent, which remarks that “stored energy in a compressed elastic fluid is utilised in a controlled manner to pressurise an inelastic fluid and to maintain such pressurisation. The pressurised inelastic fluid is throttled to the impeller of a prime mover. Only a portion of the output energy from the prime mover is utilised to circulate the inelastic fluid so as to maintain a nearly constant volumetric balance in the system”.

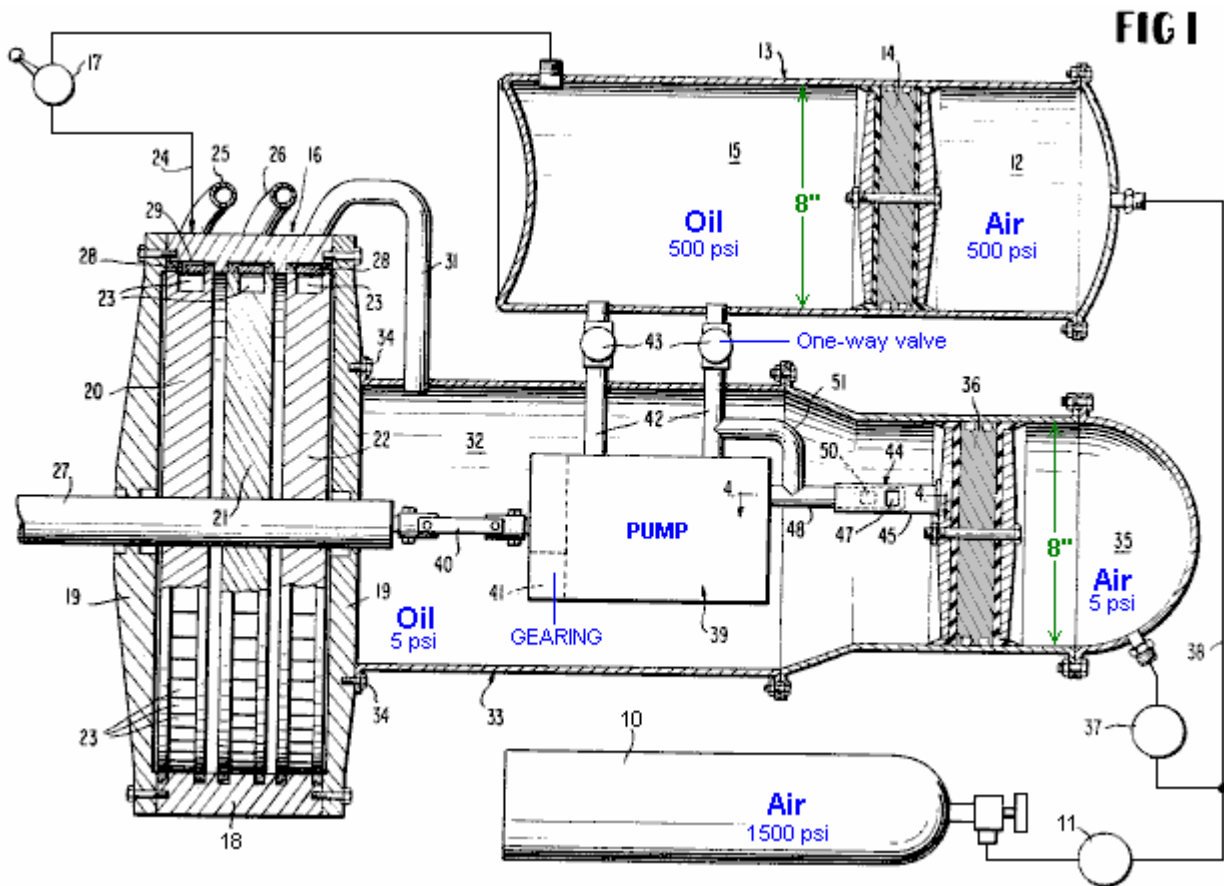

Richard Clem’s Motor.

The Clem Engine is based on an entirely different principle, and one which is not spoken about very often. Hurricanes or “twisters” as they are sometimes called, are large rotating air masses of incredible power which develop in hot areas which are more than eight degrees North or South of the equator. The distance from the equator is essential as the rotation of the Earth is needed to give them their initial spin. They usually develop over water which is at a temperature of twenty-eight degrees Centigrade or higher as that allows the air to absorb enough heat energy to get started. That is why there is a distinct “hurricane season”

in these areas, since at certain times of the year the ocean temperature is just not high enough to trigger a hurricane.

What is not generally realised is that a hurricane develops excess energy due to its swirling circular movement. The generation of this extra power was observed and documented by Viktor Schauberger of Austria, who also used his observations to great effect. I think that what Schauberger says makes some people uncomfortable as they seem to think that anything “unorthodox” has to be weird and too peculiar to be mentioned. This is rather strange as all that is involved here is a simple observation of how our environment actually works. A hurricane is wider at the top than at the bottom and this concentrates power at the base of the swirling mass of air. This tapered rotation is called a “vortex” which is just a simple name to describe the shape, but any mention of “vortex power” (the power at the base of this rotation) seems to make many people uncomfortable which is most peculiar.

Leaving that aside, the question is “can we use this energy gain from the environment for our own purposes?”. The answer may well be “Yes”. Perhaps this principle is utilised by Richard Clem. In 1992, Richard Clem of Texas, demonstrated a self-powered engine of an unusual type. This engine, which he had been developing for twenty years or more, weighs about 200 pounds (90 kilos) and generated a measured 350 horsepower continuously over the full period of a nine-day self-powered test. Although this engine which runs from 1,800 to 2,300 rpm is especially suited to powering an electrical generator, Richard did install one in a car, and estimated that it would run for 150,000 miles without any need for attention and without any kind of fuel. Richard said that his prototype car had reached a speed of 105 mph. Just after receiving funding to produce his engine, Richard died suddenly and unexpectedly at about 48 years of age, the death certificate having “heart attack” written on it as the cause of death. Remarkably convenient timing for the oil companies who would have lost major amounts of money through reduced fuel sales if Richard’s motor had gone into production.

The motor is unusual in that it is a rotary turbine style design which runs at a temperature of 300°F (140°C) and because of that high temperature, uses cooking oil as its operational fluid, rather than water as the oil has a much higher boiling point. To a quick glance, this looks like an impossible device as it appears to be a purely mechanical engine, which will definitely have an operating efficiency which is less than 100%.

In broad outline, the oil is pumped through a pipe and into the narrow end of the cone-shaped rotor. The engine is started by being rotated by an external starter motor until it reaches the speed at which it generates enough power to be sustain its own operation. The rapid spinning of the cone, causes the oil to run along spiral grooves cut in the inner face of the cone and exit through angled nozzles placed at the large end of the cone:

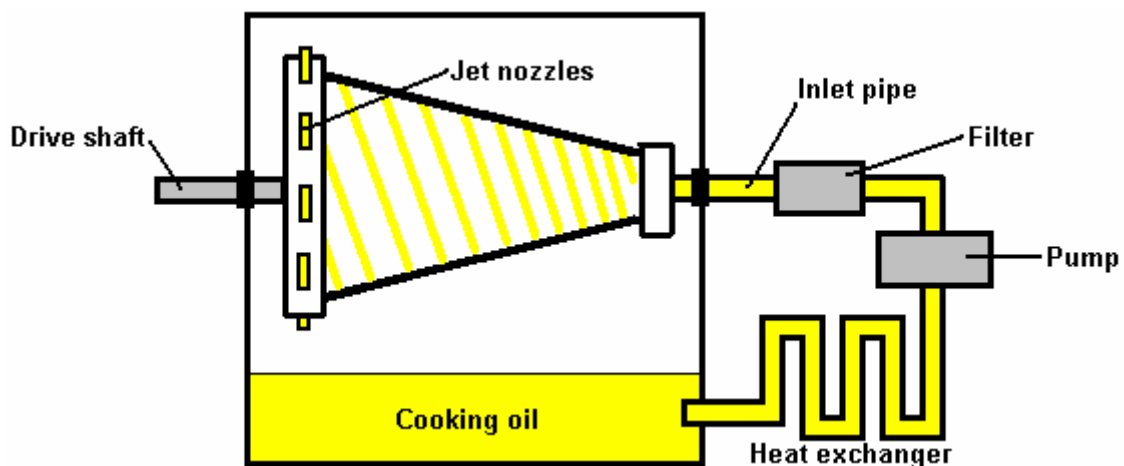

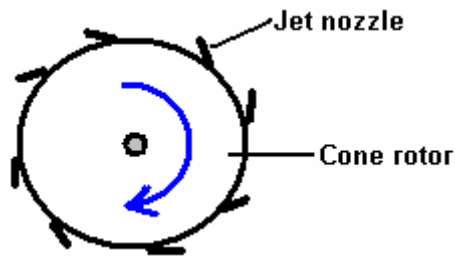

The operating pressure produced by the pump is 300 to 500 psi. Richard did not attempt to patent his engine as US Patent 3,697,190 "Truncated Conical Drag Pump" granted in 1972 as a liquid-asphalt pump is so close in detail that Richard felt that there was insufficient difference for him to be granted a patent:

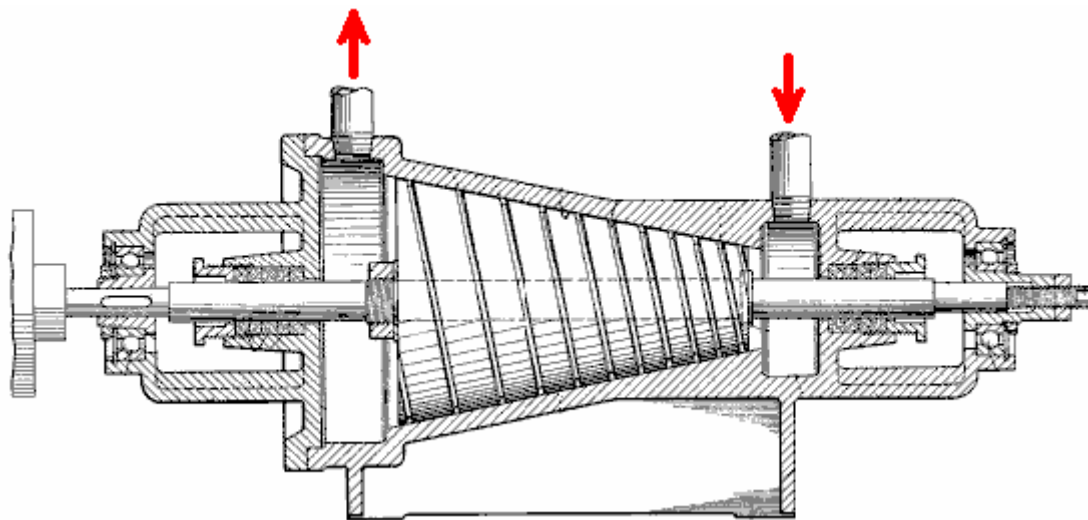

There appears to be considerable scope for anyone who wishes to build or manufacture this engine and it is capable of acting as a heater as well as device for producing mechanical power. This suggests that water purification could be an additional "extra" option for this engine.

Prof. Alfred Evert of Germany has produced an analysis of the operation of the Clem Engine and turbines in this general category. His website <http://evert.de/indefte.htm> has a good deal of information on the subject.

Josef Papp's Inert Gas Engine Conversion.

The Hungarian, Josef Papp, invented an unusual engine system which genuinely appears to be very nearly "fuel-less". His design modifies an existing vehicle engine to operate on a fixed amount of gas. That is to say, the engine has no air intake and no exhaust and consequently, no inlet or exhaust valves. The engine cylinders contain a mixture of gases which have an Atomic Number below 19, specifically, 36% helium, 26% neon, 17% argon, 13% krypton, and 8% xenon by volume. The control system causes the contained gas to expand to drive the pistons down the cylinders and then contract to suck the pistons back up the cylinders. This effectively converts the engine into a one-stroke version where there are two power strokes per revolution from every cylinder.

A small amount of radioactive material is used in the engine, and I have seen it suggested that the engine should be screened to protect the user from radiation. I'm not sure that this is correct, but if it is, then it suggests that a matter to energy conversion is indeed taking place. It seems most unlikely that the minor amount of radioactive material in the engine itself could cause any significant radiation. The patent describes the material as "low-level" which suggests to me, material no more dangerous than the luminous paint that used to be used on the hands of clocks and watches.

Suitable engines must have an even number of cylinders as they operate in pairs. Josef's first prototype was a four-cylinder, 90 horsepower Volvo engine. He removed the intake and exhaust components and

replaced the engine head with his own design. During a thirty-five minute test in a closed room, the engine generated a constant 300 horsepower output at 4,000 rpm. The electrical power needed to run the engine was produced by the standard engine alternator, which was also able to charge the car battery at the same time. Interestingly, an engine of this type, quite apart from having zero pollution emissions (other than heat), is quite capable of operating under water.

Josef, a draftsman and ex-pilot, emigrated from Hungary to Canada in 1957 where he lived until his death in April 1989. There is solid evidence that Josef built an engine of over 100 horsepower (75 kilowatts) that was "fuelled" by a mixture of inert (or "noble") gases. With no exhaust or cooling system, it had huge torque even at low rpm (776 foot-pounds at only 726 rpm in one certified test). Dozens of engineers, scientists, investors and a Federal judge with an engineering background saw the engine working in closed rooms for hours. This would not have been possible if the engine had been using fossil fuel. There was absolutely no exhaust and no visible provision for any exhaust. The engine ran cool at about 60°C (140°F) on its surface, as witnessed by several reliable observers. All these people became convinced of the engine's performance. They all failed to discover a hoax. Ongoing research in the United States (totally independent of Papp) has proved conclusively that inert gases, electrically triggered in various ways, can indeed explode with fantastic violence and energy release, melting metal parts and pushing pistons with large pressure pulses. Some of the people performing this work, or who have evaluated it, are experienced plasma physicists. Contemporary laboratory work has established that inert gases can be made to explode

In a demonstration on 27th October 1968 in the Californian desert, Cecil Baumgartner, representing the top management of the TRW aerospace corporation and others witnessed the detonation of one of the engine cylinders. In full public view, just a few cubic centimetres of the inert gas mixture was injected into the cylinder using a hypodermic needle. When the gas was electrically triggered, the thick steel walls of the cylinder were burst open in a dramatic way. William White, Edmund Karig, and James Green, observers from the Naval Underseas Warfare Laboratory had earlier sealed the chamber so that Papp or others could not insert explosives as part of a hoax. In 1983, an independent certification test was carried out on one of the Papp engines. Joseph Papp was issued three United States patents for his process and engines:

US 3,680,431 on 1st August 1972 "Method and Means for Generating Explosive Forces" in which he states the general nature of the inert gas mixture necessary to produce explosive release of energy. He also suggests several of the triggering sources that may be involved. It appears that Papp is not offering full disclosure here, but there is no doubt that others who have examined this patent and followed its outline have already been able to obtain explosive detonations in inert gases.

US 3,670,494 on 20th June 1972 "Method and Means of Converting Atomic Energy into Utilisable Kinetic Energy" and

US 4,428,193 on 31st January 1984 "Inert Gas Fuel, Fuel Preparation Apparatus and System for Extracting Useful Work from the Fuel". This patent shown here, is very detailed and provides information on building and operating engines of this type. It also gives considerable detail on apparatus for producing the optimum mixture of the necessary gasses.

At the time of writing, a web-based video of one of the Papp prototype engines running on a test bed, can be found at http://www.youtube.com/watch?v=N4li_z4Jpso although it must be said that a good deal of the footage is of very poor quality, having been taken many years ago. The video is particularly interesting in that some of the demonstrations include instances where a transparent cylinder is used to show the energy explosion. Frame-by-frame operation on the original video shows energy being developed outside the cylinder as well as inside the cylinder, which does seem to suggest that the zero-point energy field is involved. I have recently been contacted by one man who attended some of the engine demonstrations run by Papp and he vouches for the fact that the engine performed exactly as described.

Papp's Patent US 4,428,193 is shown in full in the Appendix.

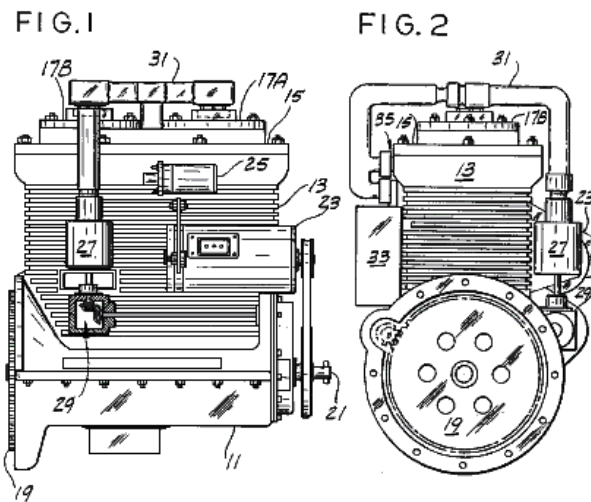

Josef never managed to get his engine design into commercial production before his death, primarily due to the opposition of vested interests. However, his design principles have been picked up and advanced by John Rohner and Haik Biglari.

The "Plasmic Transition Process" is the subject of various patents pending by PlasmERG Inc. of Iowa. John Rohner founded this company in 2008 to be the means to disseminate, develop and license this technology to other motor manufacturers for their own use. This process originally called the "Papp Engine" did run in 1982 and was then lost until John, and his partner Haik Biglari rediscovered it and applied modern science to the system to explain the process and filed their patents, presently pending. The original process was based on information originally patented by the late Joseph Papp, whose patents have now expired. John Rohner, a well known new-product design engineer, was originally contacted in 1979 by his brother Robert, with a schematic for the controller which Papp had designed. Unfortunately, John was busy with several other projects so he turned it over to his brother Tom.

PlasmERG has designed two motors for Own-Equipment-Manufacturers to use. One is an opposed, 2-cylinder, 120 cubic inch engine which produces some 300 horsepower. The second is a 6-cylinder 360 cubic inch engine which can produce around 1,500 horsepower. These motors are being co-developed with a sister company in Canada. John Rohner has personally provided the total investment for this development. As the company moves toward manufacturing, they are seeking investment partners by trading stock for investment. Their first commercial manufacturing plant will cost about 10 million dollars.

An alternative strategy is to create licenses for existing car and truck motor manufacturers until they can fund their own production. The current plan is to provide 500 to 1,000 test sites in underdeveloped nations for water pumping and power generation as "humanitarian" test sites. This should allow the time needed to get production understood and patents completed.

The expected run time of a motor from a single inert gas charge is over 3 months of continuous operation and gas re-charge should cost less than US \$50. John stresses that the PlasmERG motor is **not**, (just as the original Papp engine was **not**), a "Pulsed Plasma motor". Plasma is not retained and "pulsed" as some people have supposed. What actually happens is that the plasma is recreated with each power stroke and then returns to a steady state gas on each return stroke, from which the name "Plasmic Transition" is derived.

The initial power and creation of plasma for expansion, is produced by a fusion event with a side-effect of a limited "chaotic" fission event causing a "plasmic transition" which is contained in a sealed 2-cycle rotating crankshaft motor.

There are two parallels to Plasmic Transition and power production of this motor. The first is natural lightning, which uses an almost identically similar Plasmic Transition process; and the second is steam which provides the same torque over rotational speed event characteristics. There is nothing in the ordinary internal combustion motor's operation that is comparable to either of these processes. The most crucial part of PlasmERG's motor operation is the Electronic Control System (ECS), comprising the following elements:

- Programmable micro computers;
- Radio frequency power generator;

HV spark coil initiation driver;

Various electromagnetic coil voltage switches providing base (resting) or variable (engine speed) voltages for all cylinder or reaction chamber electromagnetic coils;

On-controller DC to 12 volt DC converter;

Engine speed DC voltage (accelerator) to programmed variable voltage DC converter,

Inter controller communications port;

Instrument support for user panel and action port which receives commands from the user comprising by not limited to things like Run, Start, Throttle position, Hold speed, Brake application, Brake hard, various motor inputs and fuel container information.

The PlasmaERG's website is at <http://plasmerng.com/> but it needs Internet Explorer to display properly as it has major display problems when Firefox is used.

John Rohner's Patent Application US 2011/0113772 A1 entitled "Plasmic Transition Process Motor" can be downloaded from www.freepatentsonline.com or from www.free-energy-info.com. It shows a 2-cylinder motor as an example of the operation:

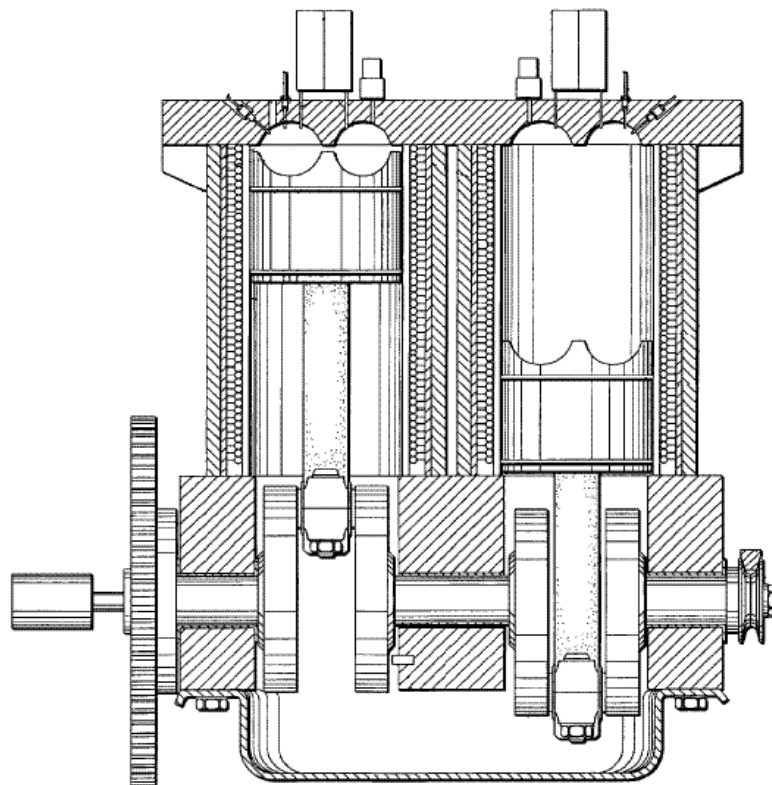

Robert Britt's Inert Gas Motor.

Robert Britt designed a very similar engine to that of Josef Papp, and he was also awarded a US patent for an engine operating on inert gasses. William Lyne remarks that this engine design may be replicated using a Chevy "Monza" 6-cylinder engine or a Volkswagen 4-cylinder engine. The heads are removed and the new heads cast using the "pot metal" used for "pseudo chrome" automotive trim. That alloy contains aluminium, tin, zinc and possibly antimony and is particularly suitable as the insides of the cavities can be polished to the high reflectivity specified in the patents.

A full copy of Robert Britt's patent US 3,977,191 is in the Appendix.

Michael Eskeli's Turbines.

In April 1989, Michael Eskeli was annoyed by a newspaper article published in the Dallas Times Herald which commented on the failure of science to come up with alternative power systems which do not rely on

petroleum products to operate. Michael responded in a letter to the Editor, stating that he holds patents for fuel-less power generators, work-free heat pumps, and other related items, 56 patents issued in the mid-70s.

Michael does hold many patents, one of which is shown in Chapter 14, as a work-free fuel-less heater. However, as I am not aware of any working prototype being shown, I must recommend that you consider the following information as “an idea” rather than a proven fact. As far as I am aware, in the 1970s, the US Patent Office did not demand to see a working prototype before granting a patent, especially if the patent related to a device based on accepted Engineering principles.

However, as Michael's claim is for self-powered devices, his claim seems too important to be ignored, prototype or no prototype, as competent people reading this may well understand the principles suggested and be in a position to build a self-powered device as a result. If that is the case, then I should really appreciate feedback information on any successful replications and the construction methods used.

As I understand it, Michael's self-powered devices are Heat Pumps where the additional energy is flowing from the heat contained in the air, courtesy of the heating effects of sunshine. Standard engineering, but with a design which utilises this available energy to provide practical mechanical output power for vehicles and electrical generators.

The Eskeli patents which I have been able to locate are:

3,650,636 Rotary Gas Compressor
3,719,434 Rotary Ejector Compressor
3,748,054 Reaction Turbine
3,748,057 Rotary Compressor with Cooling
3,758,223 Reaction Rotor Turbine
3,761,195 Compressing Centrifuge
3,795,461 Compressor with Cooling
3,809,017 Heat and Steam Generator
3,834,179 Turbine with Heating and Cooling
3,854,841 Turbine
3,861,147 Sealed Single-rotor Turbine
3,874,190 Sealed Single-rotor Turbine
3,879,152 Turbine
3,889,471 Dual-rotor Dual-fluid Turbine
3,895,491 Turbine with Dual Rotors
3,919,845 Dual-fluid Single-rotor Turbine
3,926,010 Rotary Heat Exchanger
3,931,713 Turbine with Regeneration
3,933,007 Compressing Centrifuge
3,933,008 Multi-stage Heat Exchanger
3,937,034 Gas Compressor-Expander
3,938,336 Turbine with Heating and Cooling
3,939,661 Power Generator
3,949,557 Turbine
3,961,485 Turbine with Heat Intensifier
3,962,888 Heat Exchanger
3,972,194 Thermodynamic Machine of the Vane Type
3,972,203 Rotary Heat Exchanger
3,981,702 Heat Exchanger
3,986,361 Turbine with Regeneration
4,003,673 Fluid Pressuriser
4,005,587 Rotary Heat Exchanger with Cooling and Regeneration *
4,012,164 Rotor with Recirculation
4,012,912 Turbine
4,030,856 Rotor with Jet Nozzles
4,044,824 Heat Exchanger
4,047,392 Dual Rotor Heat Exchanger *
4,050,253 Thermodynamic Machine
4,057,965 Thermodynamic Machine with Step-type Heat Addition
4,060,989 Thermodynamic Machine with Step-type Heat Exchangers
4,068,975 Fluid Pressuriser
4,077,230 Rotary Heat Exchanger with Cooling

- 4,106,304 Thermodynamic Compressor
- 4,107,944 Heat Pump with Two Rotors *
- 4,107,945 Thermodynamic Compressor
- 4,124,993 Refrigeration Machine
- 4,167,371 Method of Fluid Pressurisation
- 4,178,766 Thermodynamic Compressor Method
- 4,574,592 Heat Pump with Liquid-Gas working Fluid

And there are presumably 7 others not listed here, to raise the total to the 56 mentioned by Michael. I do not have the expertise to tell which of these may be self-powered just by reading the patent information, which generally does not mention anything along those lines, (the Patent Office staff not believing that COP>1 exists). Practically any of these patents might fit Michael's description, so I will pick the following patents to reproduce here:

- 4,107,944 Heat Pump with Two Rotors (continuing 4,005,587 and 4,047,392)
- 4,012,912 Turbine, and
- 3,931,713 Turbine with Regeneration

US Patent 4,107,944

22nd August 1978

Inventor: Michael Eskeli

HEAT PUMP WITH TWO ROTORS

ABSTRACT

A method and apparatus for generating heating and cooling by circulating a working fluid within passageways carried by rotors, compressing the working fluid in them and removing heat from the working fluid in a heat-removal heat exchanger and adding heat into the working fluid in a heat-addition heat exchanger, all carried within the rotors. The working fluid is sealed in, and may be a suitable gas, such as nitrogen. A working fluid heat exchanger is also provided to exchange heat within the rotor between two streams of working fluid. In one arrangement, the unit uses two rotors, both rotating; in an alternate arrangement, one of the rotors may be held stationary. Applications include air conditioning and heating applications.

US Patent References:

2,490,064	Thermodynamic Machine	Dec 1949	Kollsman
2,490,065	Thermodynamic Machine	Dec 1949	Kollsman
2,520,729	Machine for producing Heat Energy	Aug 1950	Kollsman
2,597,249	Thermodynamic Engine	May 1952	Kollsman
3,470,704	Thermodynamic Apparatus and Method	Oct 1969	Kantor
3,834,179	Turbine with Heating and Cooling	Sep 1974	Eskeli
3,861,147	Sealed Single-rotor Turbine	Jan 1975	Eskeli
3,889,471	Dual-rotor Dual-fluid Turbine	Jun 1975	Eskeli
3,895,491	Turbine with Dual Rotors	Jul 1975	Eskeli
3,919,845	Dual-fluid Single-rotor Turbine	Nov 1975	Eskeli
3,931,713	Turbine with Regeneration	Jan 1976	Eskeli
4,005,587	Rotary Heat Exchanger with Cooling & Regeneration	Feb 1977	Eskeli
4,044,824	Heat Exchanger	Aug 1977	Eskeli

Cross References to Related Applications

This application is a continuation-in-part application of "Dual Rotor Heat Exchanger" filed Nov. 18, 1973, Ser. No. 407,665, now U.S. Pat. No. 4,047,392.

This application also is a continuation-in-part of "Heat Pump" filed June 30, 1975, Ser. No. 591,881, now abandoned.

And this application also is a continuation-in-part of "Rotary Heat Exchanger with Cooling and Regeneration" filed Oct. 1, 1975, Ser. No. 618,456, now U.S. Pat. No. 4,005,587.

BACKGROUND OF THE INVENTION

This invention relates generally to devices for heat transfer from a lower temperature to a higher temperature by using a working fluid enclosed within a centrifuge rotor as an intermediate fluid to transport the heat.

Heat pumps have been known in the past but are complex and costly, and usually use a working fluid that is evaporated and condensed, which results in poor efficiency, and thus high energy cost.

SUMMARY OF THE INVENTION

It is an object of this invention to provide apparatus that is low in initial cost and has high thermal efficiency thus reducing cost of the power required to run it. It is further the object of this invention to provide a device and process wherein the losses that normally occur in bearings and seals, due to friction, are applied to the working fluid for its circulation, thus in effect eliminating the power loss due to such friction losses. Also, it is an object of this invention to provide the rotor with a working fluid heat exchanger to reduce needed rotor speeds.

BRIEF DESCRIPTION OF THE DRAWINGS

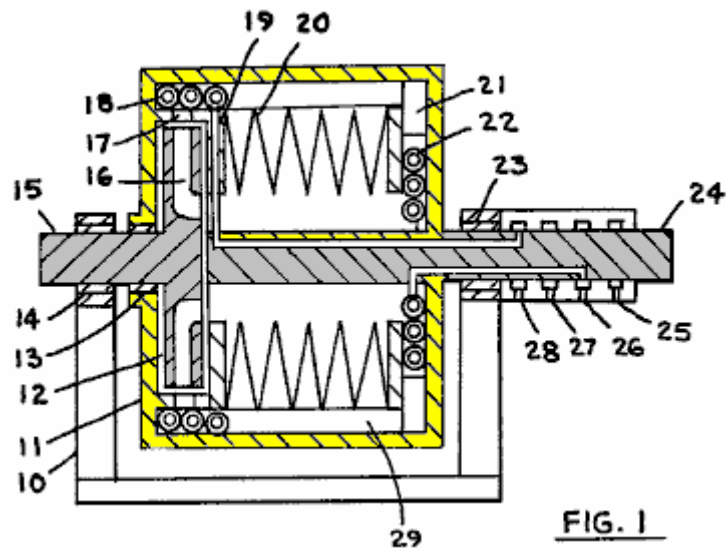

Fig.1 is a cross section of the device.

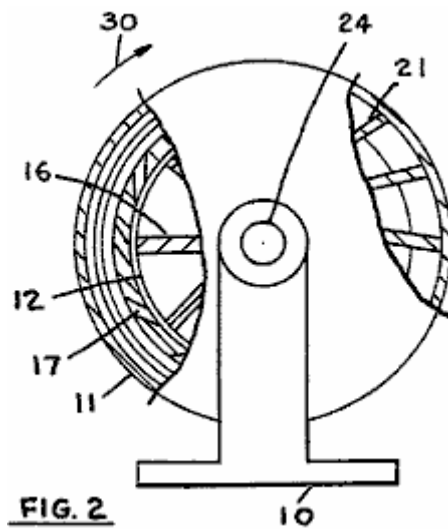

Fig.2 is an end view of the device.

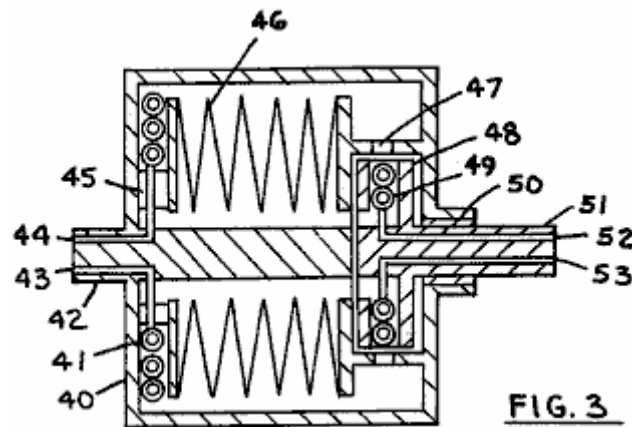

Fig.3 is an axial cross section of another form of the device.

DESCRIPTION OF PREFERRED EMBODIMENTS

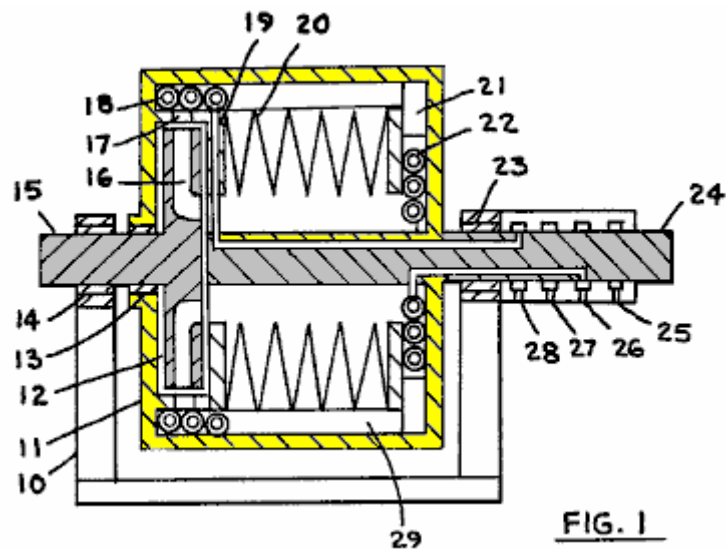
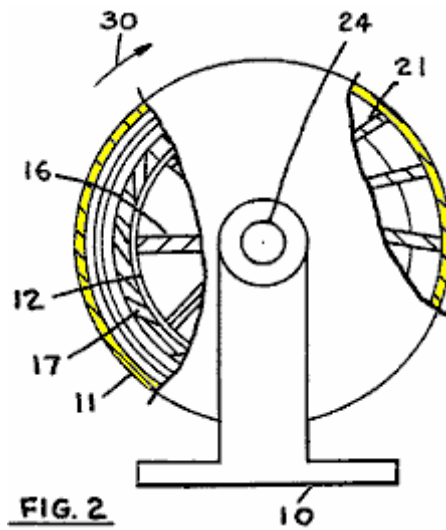
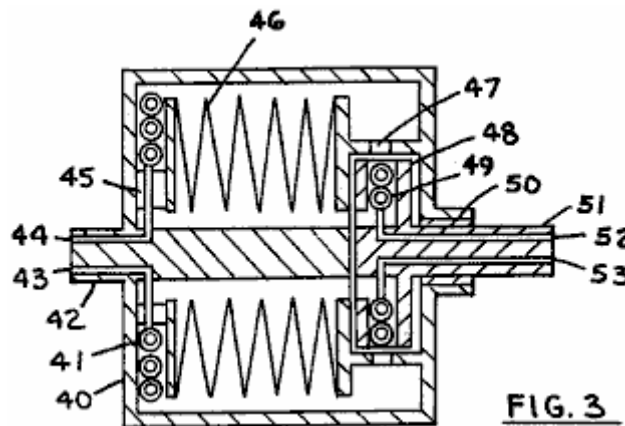

Fig.1 shows an axial cross section of the device, where 10 is the base, 11 is the first rotor, 12 is the second rotor, 13 is a seal and 14 is the bearing supporting shaft 15, 16 is fluid passage in the second rotor, 17 is the

working fluid opening which may be a nozzle, **18** is the first heat exchanger for heat removal from working fluid, **19** is first heat transfer fluid conduit, **20** is working fluid heat exchanger, in this instance formed from sheet metal like bellows, **21** are vanes, **22** is second heat exchanger for heat addition to working fluid, **23** is bearing supporting shaft **24**, **25** and **26** are entry and exit for second heat transfer fluid, **27** and **28** are entry and exit for first heat transfer fluid, and **29** is a vane in peripheral passage.



In **Fig.2**, an end view of the unit shown in **Fig.1** is illustrated. Where **10** is base, **11** is first rotor, **17** are fluid openings, **12** is second rotor, **16** are second rotor fluid passages with vanes, **30** indicates direction of rotation, **24** is first rotor shaft, and **21** are vanes.



In **Fig.3**, the rotors are arranged differently, but perform the same functions, approximately, as in the unit of **Fig.1**. Where **40** is first rotor, **41** is first heat exchanger for heat removal from first fluid, **42** is first rotor shaft, **43** and **44** are entry and exit for first heat transfer fluid, **45** is conduit, **46** is working fluid heat exchanger, **47** are fluid openings which may be nozzles, **48** is second rotor, **49** is second heat exchanger for adding heat to the working fluid, **50** is bearing and seal, **51** is second rotor shaft, **52** and **53** are entry and exit for second heat transfer fluid.

In operation, the rotors are caused to rotate and the rotor cavities are filled with a suitable working fluid, which is usually a gas, such as nitrogen, air or other gaseous or vapour substance. Referring to **Fig.1**, the second rotor rotates usually faster than the first rotor, and the working fluid is compressed by centrifugal force in passages **16**, and in the first rotor to some extent, after which heat is removed in heat exchanger **18**, with such heat then being transported by the first heat transfer fluid out of the device. The working fluid then passes along the peripheral passage **29** and releases heat in heat exchanger **20**, after which the fluid is expanded against centrifugal force in vanes **21** and in heat exchanger **22** where heat is added to the working fluid. After expansion, the working fluid passes along centre passage and receives heat from heat exchanger **20**, thus completing its work cycle.

The operation of the unit in **Fig.3** is similar, except that the second rotor usually rotates slower than the first rotor, and the second rotor may be kept stationary, if desired. Note that if the second rotor is held stationary, one may use dirty water as the second heat transfer fluid; normally, in rotating heat exchangers,

the heat transfer fluid must be free of solids, which will collect in the heat exchanger due to centrifugal force, and block the heat exchanger, and by having a stationary heat exchanger, ordinary water may be used, such as water from a cooling tower.

In the unit of **Fig.1**, the power input is normally to the second rotor, and the first rotor is allowed to rotate freely. In such usage, the rotor diameters are selected to provide, together with the friction loss in bearings, for the needed speed differential between the two rotors. With the second rotor rotating faster, necessary push for the working fluid is provided to keep the working fluid circulating. Alternately, the speed differential may be maintained by using a power transmission between the two rotors, such as a gearbox. In the unit of **Fig.3**, the second rotor speed is slower than the speed of the first rotor, and where the rotor diameters are suitable, the second rotor may be held stationary, providing needed push for the working fluid for its circulation.

The working fluid heat exchanger **20** and **46**, employ centrifugal force and varying gas density to obtain heat exchange between the two working fluid streams. Hot gas in the peripheral passage is lighter, and colder gas between the folds of the heat exchanger is colder, thus the cold gas is displaced by lighter gas by centrifugal force. Similarly, at the centre passage, cold gas at centre displaces hot gas between folds. Other types of heat exchangers may be used for the heat exchanger **20**, including heat pipes, sheet metal discs, and finned tubing filled with a liquid.

The rotor may be encased within a vacuum tank, if desired, to reduce friction on rotor outer surfaces. The use of the working fluid heat exchanger **20** will reduce required rotor speeds to obtain required temperature differentials between the two heat transfer fluids, which then reduces friction losses on the rotor, which may eliminate the need for a vacuum tank.

Various modifications of this device may be made, and different types of heat exchangers used. Also, working fluid radial passages may be curved in various directions, one being the slope for vanes shown as item **21** in **Fig.2**. By using vane slopes and sloped passages, one can adjust the amount of work exchange between the working fluid and the rotor. Nozzles **47** are usually positioned so as to discharge backwards, in order to generate some torque on the first rotor, and similar nozzles may also be used in passages **21** of the unit shown in **Fig.1**. Further, the heat exchanger **22**, of **Fig.1**, may be mounted on a stationary member, if desired, in manner shown in **Fig.3**, and heat exchanger **18** may be mounted within rotor **12**, if desired. The various components of the units may be interchanged, as desired.

CLAIMS

1. In a heat pump wherein a compressible working fluid is circulated radially outwardly in a first fluid passage, said first passage contained in a first member, and radially inwardly towards centre of rotation in a second fluid passage, said second passage contained in at least one of said first and second members, said first and second members coaxially arranged, at least one of said members being supported by a shaft for rotation;
said first and said second radial working fluid passages communicatingly connected at their respective outward ends by an outer passage and at their respective inward ends by an inner passage, said radial and outer and inner passages forming a closed loop extending at least partially through both of said members, a working fluid adapted to be circulating through said loop, means for compressing said working fluid by centrifugal force within said loop with accompanying temperature increase, first heat exchange means for cooling said working fluid after compression, said first heat exchange means being carried by one of said members, a second heat exchange means, carried by one of said members, for regeneratively exchanging heat between said working fluid within said inner and outer passages, and a third heat exchange means carried by one of said members for heating said working fluid after said heat exchange between said working fluid within said inner and outer passages.
2. The heat pump of claim 1 wherein a first heat transfer fluid is circulated within said first heat exchange means to remove heat with said first heat exchange fluid entering and leaving via conduits near the centre of rotation of said members.
3. The heat pump of claim 1 wherein a second heat transfer fluid is circulated within said third heat exchange means entering and leaving via conduits near the centre of rotation of said members.
4. The heat pump of claim 1 wherein both of said members are rotors.
5. The heat pump of claim 4 wherein the two rotors rotate at different angular speeds.
6. The heat pump of claim 1 wherein at least one of said members is a rotor.

7. The heat pump of claim 6 wherein said second heat exchange means includes a plurality of folds.
8. The heat pump of claim 7 wherein said second heat exchange means is of bellows configuration.

US Patent 4,012,912

22nd March 1977

Inventor: Michael Eskeli

TURBINE

ABSTRACT

A method and apparatus for the generation of power wherein a working fluid is compressed within outward extending rotor passages, and then passed inward in other rotor passages with accompanying expansion and deceleration, with work being generated by the decelerating fluid. Heat may be added into the working fluid near the rotor periphery, and in closed rotors, heat is removed from the working fluid after expansion. A regenerator may also be used, mounted on the rotor, exchanging heat between two streams of the working fluid. During the deceleration, the working fluid passages are curved backwards, while the working fluid passages for acceleration are usually radial. The working fluid may be either a liquid or a gas, and the heating fluid and the cooling fluid may also be either a liquid or a gas.

US Patent References:

3,761,195 Compressing Centrifuge	Sept 1973	Eskeli
3,834,179 Turbine with Heating and Cooling	Sept 1974	Eskeli
3,926,010 Rotary Heat Exchanger	Dec 1975	Eskeli

Cross References to Related Applications:

This application is a continuation-in-part application of "Turbine," Ser. No. 566,373, filed 4-9-75 now U.S. Pat. No. 3,949,557.

BACKGROUND OF THE INVENTION

This invention relates to power generators where a working fluid is circulated from a higher energy level to lower energy level, generating power.

In my earlier U.S. Pat. Nos. 3,874,190 and 3,854,841, I described a closed and open type turbines, and using centrifuge design. These turbines used forward facing nozzles within the rotor; in the apparatus disclosed here, such nozzles have been replaced by other methods.

SUMMARY OF THE INVENTION

It is an object of this invention to provide a single rotor centrifuge type turbine stage, where vanes or fins, with suitable contours, are used to extract power from the working fluid, using either an open type or a closed type rotor.

BRIEF DESCRIPTION OF THE DRAWINGS

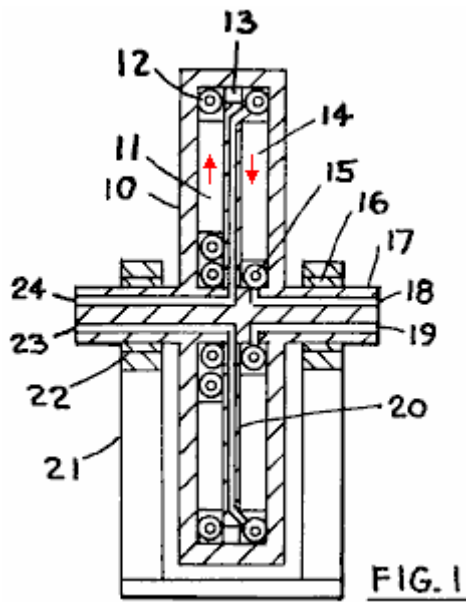

Fig.1 is a cross section and

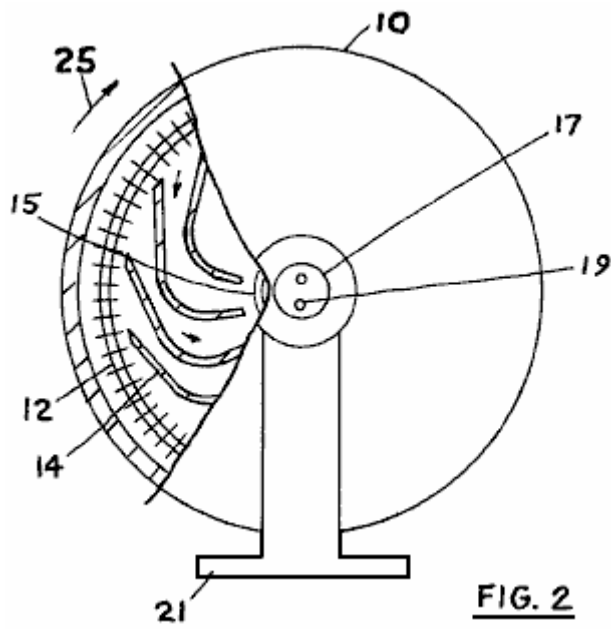

Fig.2 is an end view of a closed type rotor.

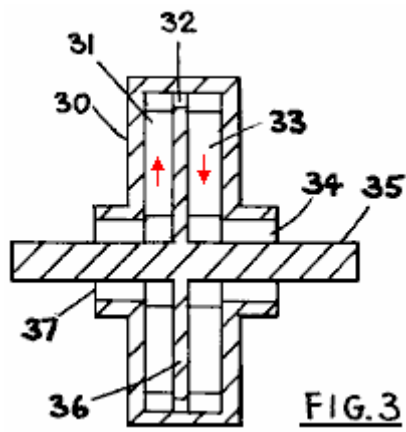

Fig.3 is a cross section and

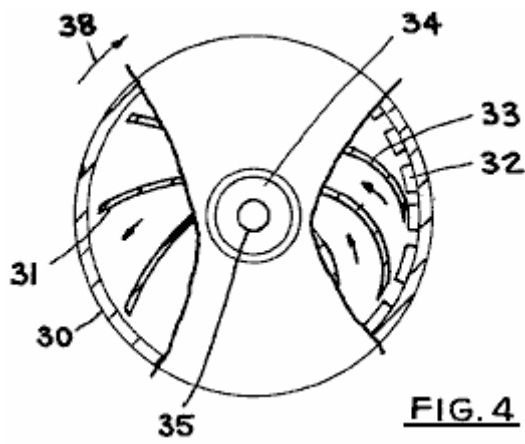

Fig.4 is an end view of an open type rotor.

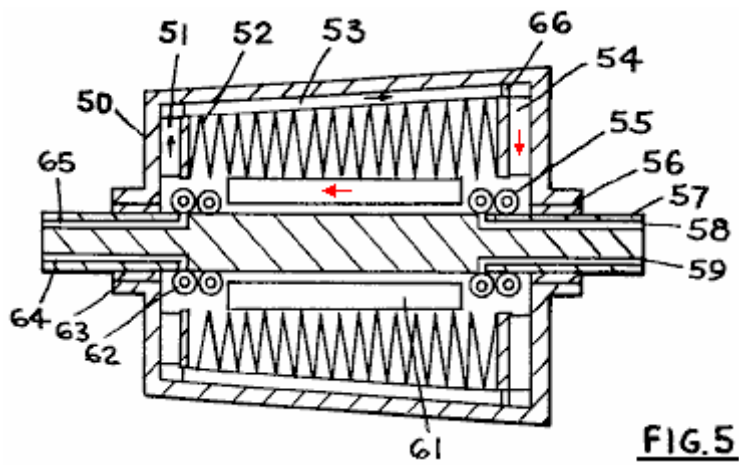
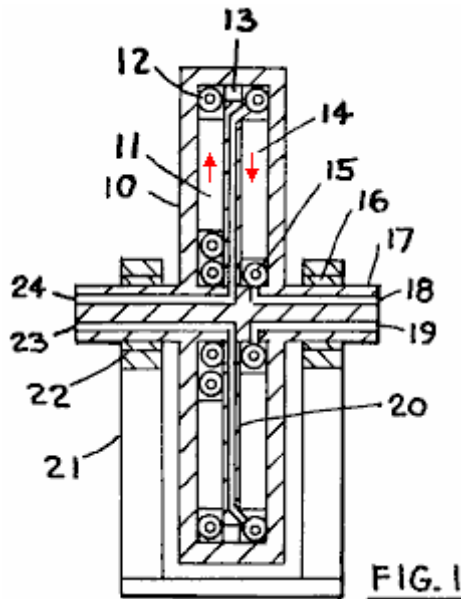

Fig.5 is a cross section of a unit using a closed type rotor and also using a regenerator.

DESCRIPTION OF PREFERRED EMBODIMENTS



Referring to **Fig.1**, there is shown a cross section of one form of the unit. Where **10** is the rotor which is supported by bearings **16** and **22**, shaft **17** and base **21**. **12** is a heat supply heat exchanger and **15** is cooling heat exchanger, **14** and **11** are vanes or fins, **18** and **19** are coolant entry and exit, **20** is a dividing wall, **23** and **24** are heating fluid entry and exit, and **13** is a working fluid passage which may be used to regulate the flow of working fluid within the rotor.

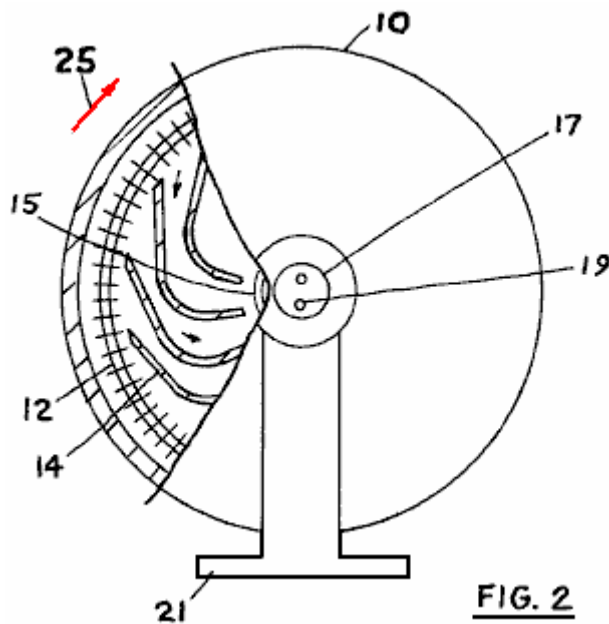

Fig.2 is an end view of the unit shown in **Fig.1**. Where **10** is the rotor, **17** the shaft, **19** is a coolant passage, **21** is the base, **14** are vanes positioned so that they slope away from the direction of rotation as indicated by arrow **25**, while simultaneously passing the working fluid inwards, **12** is the heating heat exchanger, and **15** is the cooling heat exchanger.

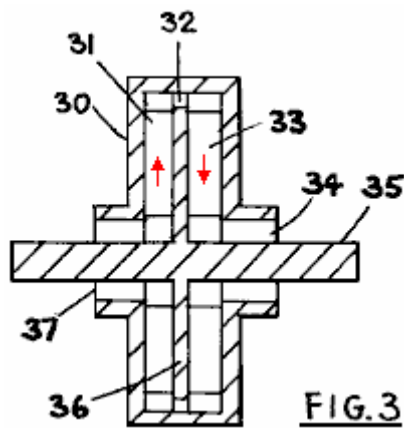

FIG. 3

In **Fig.3**, a rotor for a unit using open cycle is used, where the working fluid enters and leaves the rotor. Here, **30** is the rotor, **31** is the vane situated in a passage which extends outwards, **32** is the fluid passage, **33** is a vane in the passage for inward bound working fluid, **34** is the working fluid exit, **35** is the rotor shaft, **36** is a rotor internal divider and **37** is the working fluid entry into the rotor.

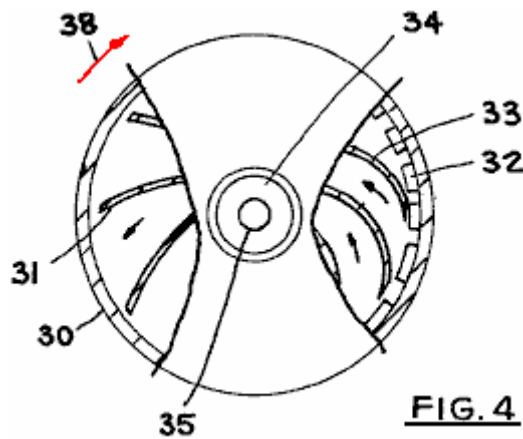

FIG. 4

Fig.4 shows an end view of the unit of **Fig.3** where **30** is the rotor, **35** is the shaft, **31** are vanes in the passages for outward bound fluid, and are shown here to be curved backwards, when the rotor rotates in the direction shown by arrow **38**. After passing openings **32**, the working fluid passes inwards guided by vanes **33**, and then leaving via exit **34**. Vanes **33** are curved as indicated, with the curvature being away from the direction of rotation, so the working fluid provides thrust against the rotor components as it decelerates when passing inwards toward the centre of the rotor.

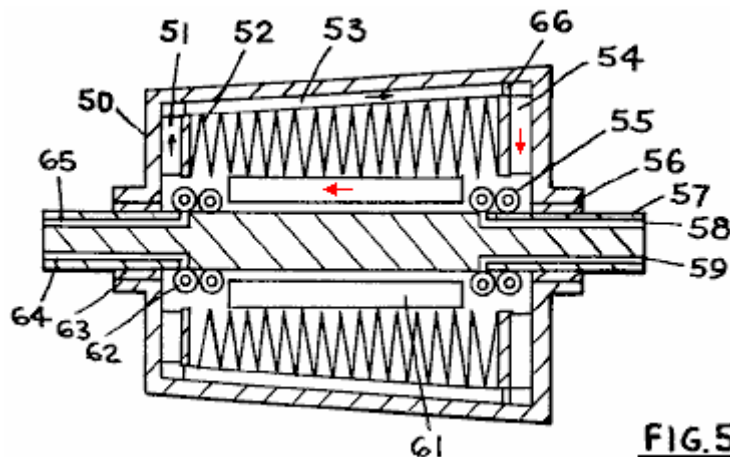

FIG. 5

In **Fig.5**, a rotor with a regenerator is shown, and also the rotor shaft is arranged so that it can be kept stationary if desired. **50** is the rotor which is supported by bearings **56** and **63** and shaft **57**. Vanes **51** may be radial or curved as desired, and vanes **54** are curved in a manner similar to vanes **33** in **Fig.4**. **52** is a

regenerative heat exchanger, exchanging heat between the working fluid streams flowing in passages **53** and **61**. Heat supply heat exchanger **55** and cooling heat exchanger **62** are attached to the shaft, so that the shaft may be kept stationary or rotated at a different speed than the rotor **50**. **58** and **59** are the entry and exit points for the heating fluid while **64** and **65** are the entry and exit points for the cooling fluid, and **66** is an opening.

When operating, the rotor rotates, and a working fluid within the rotor passes outwards in passage **11**, and is compressed by centrifugal force, and accelerated to a tangential speed that may be the same as that for the rotor periphery. In a closed rotor such as is shown in **Fig.1**, heat is added into the working fluid near the rotor periphery, and then the working fluid decelerated in the fluid passages **14** extending inwards toward rotor centre, with the passages being curved backwards away from the direction of rotation as shown in **Fig.2**. As the working fluid is decelerated in the inward extending passages, the work associated by such deceleration is transferred into the rotor and this provides the thrust and torque to rotate the rotor. After deceleration and expansion, the working fluid is cooled in heat exchanger **15** and then passed to the outward extending passages thus completing its working cycle.

The operation of the unit of **Fig.3** is similar, except that the working fluid enters the rotor via opening **37** from external sources. For the unit shown in **Fig.3**, the heat addition heat exchanger is omitted; for this unit, there is a pressure drop between entry **37** and exit **34**. A heat exchanger similar to that shown in **Fig.1**, item **12**, may be used in the unit of **Fig.3**, and then the entry and exit pressure for the working fluid may be the same, if desired.

The operation of the unit shown in **Fig.5**, is similar to that described for the other units. The rotor rotates, and by centrifugal force, compresses the working fluid in passages **51**, and then the working fluid gains heat in the regenerative heat exchanger, with the heat being supplied by another working fluid stream returning from the high temperature end of the unit. The working fluid is expanded and decelerated in passages **54** and heat is added in the heat exchanger **55**. Then the working fluid passes through the regenerative heat exchanger and then is cooled in the cooling heat exchanger and then is passed into passages **51** thus completing its cycle.

The various components of the units shown can be exchanged to make additional forms of the apparatus. As noted, the unit of **Fig.3** may be provided with a heat exchanger similar to that shown in **Fig.1** for adding heat into the working fluid near the rotor periphery. Further, a regenerator may be provided with the units of **Fig.1** and **Fig.3**, if desired, between the outward extending and the inward extending working fluid passages. Also, the cooling coil of **Fig.5**, item **62** may be eliminated, and the working fluid taken into the unit from outside the unit, if desired.

The openings **32**, **13** and **66** may be made into nozzles, if desired, and the nozzle oriented in different directions as desired. In particular, these nozzles may be positioned so as to discharge the working fluid tangentially backwards, if desired.

The regenerator of **Fig.5** is shown to be tapered. This taper may be as shown, or the taper may be made such that the regenerator portion diameter is smaller at the end which has the heat exchanger **55**, than the end which has the heat exchanger **62**. Also, the regenerator may be made without a taper.

Passages **53** and **61** are usually provided with vanes, as indicated in **Fig.5**, to prevent tangential movement of the working fluid.

Applications for this power generator are those normally encountered in power generation.

The working fluid is usually a gas for units such as those shown in **Fig.1** and **Fig.5**, but the working fluid may also be a liquid for a unit such as shown in **Fig.3**. The heating and cooling fluids may be either gases or liquids, as desired.

The heat exchangers for heating and cooling are shown to be made of finned tubing. Other forms of heat exchangers for adding heat and for removing heat may be used. The regenerative heat exchanger is shown to be made of sheet metal; other forms of heat exchangers may be also used.

TURBINE WITH REGENERATION**ABSTRACT**

A method and apparatus for generating power by passing a motivating fluid from a higher energy level to a lower energy level by compressing the fluid in a centrifuge-type first rotor and discharging the fluid via nozzles near the periphery of the first rotor, forwards in the direction of rotation to a second rotor which is an inward flow type reaction turbine, then passing the fluid through a regeneration type heat exchanger to transfer heat from the inward bound fluid into the outward bound fluid, after which the fluid is cooled in a heat exchanger to its original temperature and is passed outward again thus completing its cycle. Heat is added to the fluid near the periphery of the second rotor, or the heat may be added near the periphery of the first rotor, or both. Additionally, the fluid may be supplied to the unit from outside source, and returned to such outside source, and the cooling may thus be eliminated from the unit. Further, the fluid entering from an outside source may be at an elevated pressure. The fluids used may be gaseous, which is normal for a closed type unit, or they may be liquids at entry for the open type unit.

US Patent References:

2,490,064	Thermodynamic Machine	Dec 1949	Kollsman
2,514,875	U-passage Gas Turbine	July 1950	Kollsman
2,597,249	Thermodynamic Engine	May 1952	Kollsman
3,236,052	Closed-cycle Gas Turbines	Feb 1966	Guin
3,530,671	Regenerative Air Turbines	Sep 1970	Kolodziej

This application is a continuation-in-part application of "Turbine with Dual Rotors," Ser. No. 405,628, filed 10/11/73, and uses material of a previous U.S. Pat. No. 3,834,179, "Turbine with Heating and Cooling".

BACKGROUND OF THE INVENTION

This invention relates generally to devices for generating power in response to a fluid flowing from a higher energy level to a lower energy level passing through a turbine for generating the power.

There have been various types of turbines previously, in some of which a fluid is accelerated in a single or multiple stationary nozzles and then passed to vanes mounted on a rotating rotor wheel, where the kinetic energy contained by the moving fluid is converted to power by deceleration of the fluid.

These conventional turbines normally have a high energy loss due to fluid friction, especially between rotor vanes and the fluid where the velocity differential is usually large. Also, these turbines often require complex shaped turbine vanes making the unit costly.

SUMMARY OF THE INVENTION

It is an object of this invention to provide a turbine for power generation in which heat is converted to power, in an efficient and economical manner, and with high thermal efficiency. It is also an object of this invention to provide a means for transferring heat from the motivating or working fluid, which is the first fluid, during its passage from rotor periphery to rotor centre into the first fluid which is passing from the rotor centre towards the rotor periphery. This heat transfer improves the efficiency of the turbine, and reduces the necessary rotational speed of the rotor, allowing less costly rotor construction.

BRIEF DESCRIPTION OF THE DRAWINGS

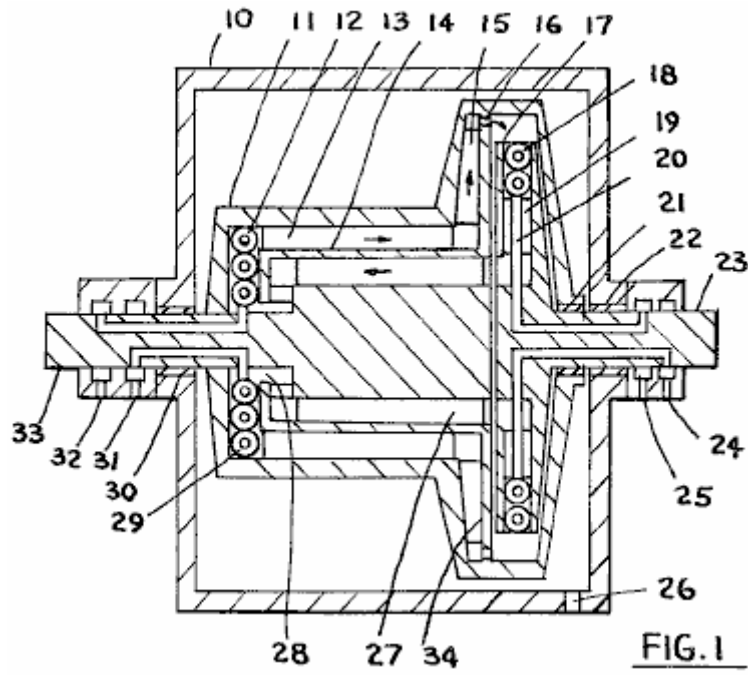

Fig.1 is a cross section of one form of the device, and

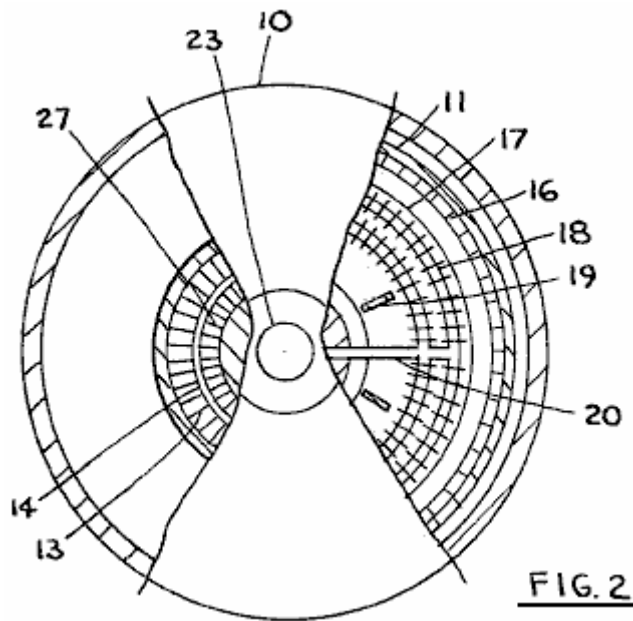

Fig.2 is an end view of the unit shown in Fig.1.

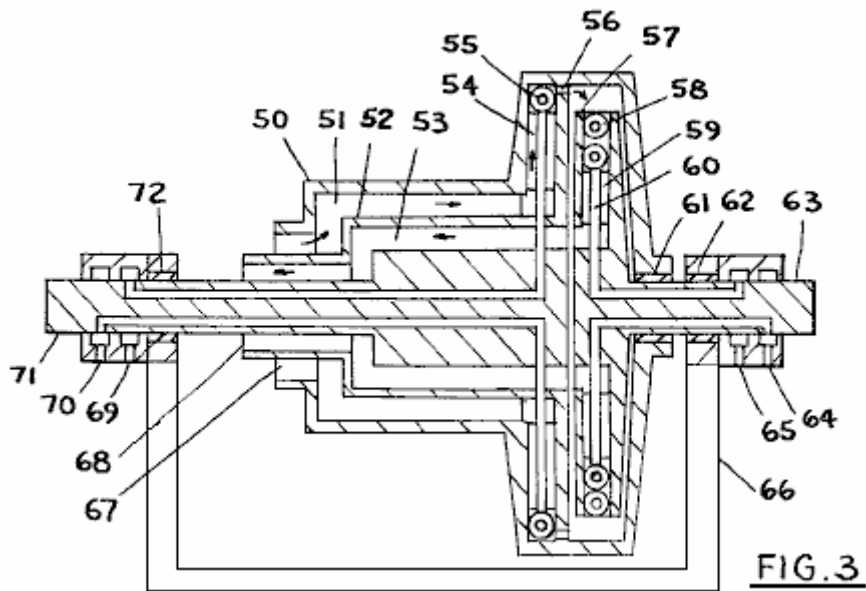

Fig.3 is a cross section of another form of the device.

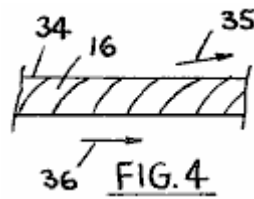

Fig.4 is a detail of rotor nozzles.

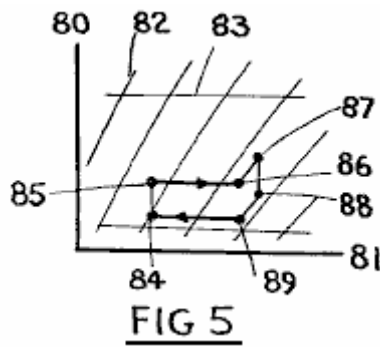

Fig.5 is a pressure-enthalpy diagram of the first fluid with working cycle illustrated for the first fluid.

DESCRIPTION OF THE PREFERRED EMBODIMENTS

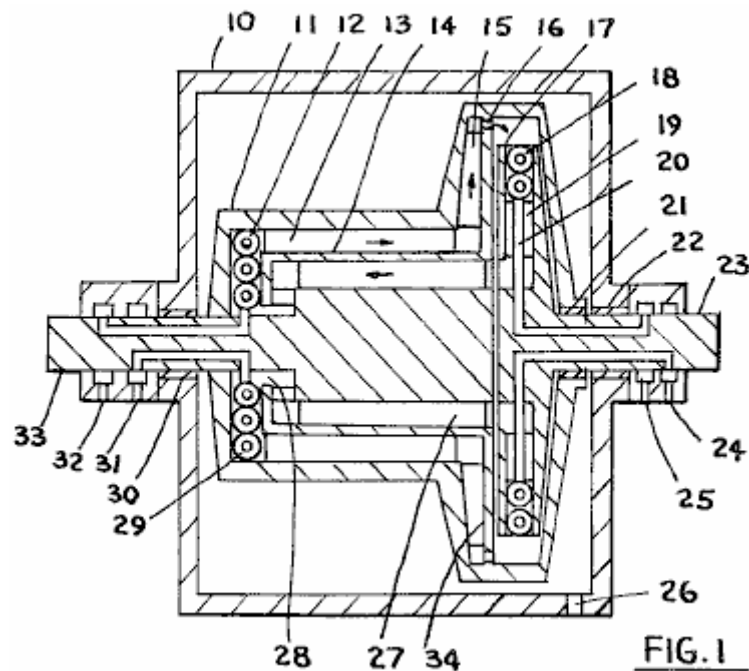

Fig.1 shows a cross section of one form of the turbine. In this form, the first fluid is sealed within the rotor with a second fluid which supplies heat to the first fluid, and a third fluid which cools the first fluid, being circulated from external sources.

The first fluid is accelerated and compressed within the first rotor, and after discharge from the nozzles of the first rotor, into the second rotor, where it receives heat from the second fluid, and after deceleration and expansion the first fluid passes in heat exchange relationship with the first fluid flowing outward so that heat is transferred from the inward bound first fluid to the outward bound first fluid. Cooling is then provided for the first fluid to bring the first fluid temperature to an initial predetermined value.

In **Fig.1**, **10** is the casing, **11** is the first rotor, **12** is the third fluid heat exchanger, **13** is the vane which also serves as a heat exchange member, **14** is a heat-conductive wall, **15** is a vane, **16** is a nozzle, **17** is the second rotor, **18** is the second fluid heat-exchanger, **19** is a vane, **20** is the second-fluid conduit, **21** is a combined bearing and seal, **22** is a combined bearing and seal, **23** is a second rotor shaft for the delivery of power, and for support of the second rotor, **24** and **25** are supply and return for the third-fluid, **26** is a vent opening in the casing into which a vacuum source may be connected, **34** is a dividing wall, **27** are vanes serving also as heat-exchange members, **28** is a first-fluid passage, **30** is a combined bearing and seal, **31** and **32** are the second-fluid entry and exit points, and **33** is the first rotor shaft.

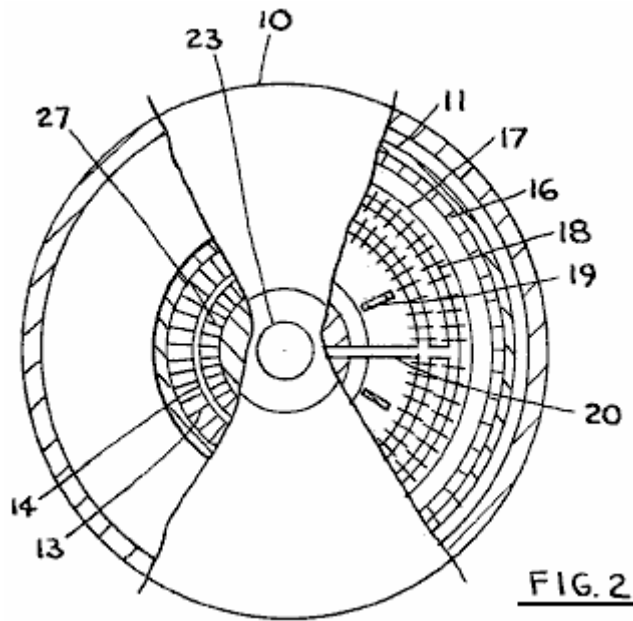

Fig.2 shows an end view of the unit of **Fig.1** where **10** is the casing, **11** is the first rotor, **17** is the second rotor, **16** are the first-fluid nozzles, **18** is a heat exchanger, **19** are vanes, **20** is a conduit, **13**, **14** and **27** form a heat exchanger for the first-fluid and **23** is the second rotor shaft.

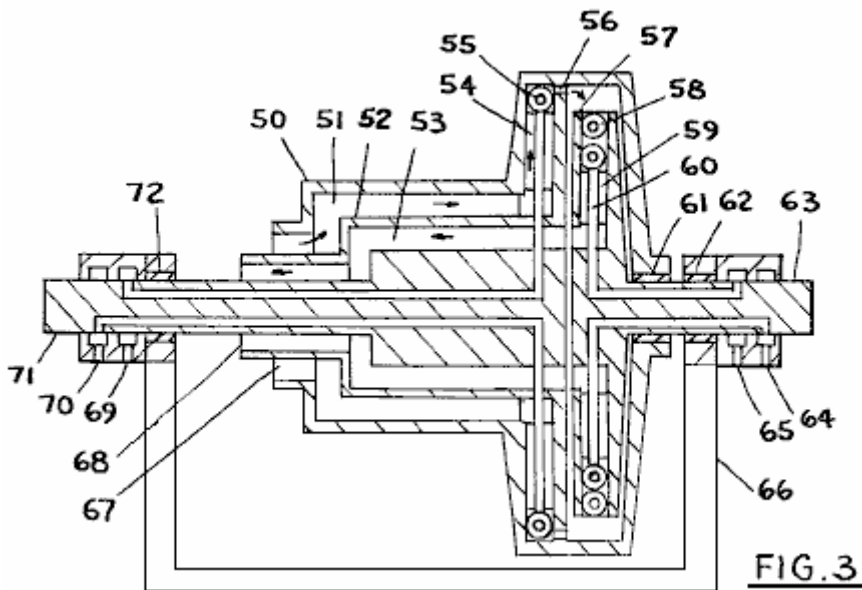

Fig.3 shows another form of the turbine, where the first-fluid is supplied to the turbine from outside sources thus eliminating the third-fluid heat exchanger. **50** is the first rotor, **51**, **52** and **53** form a heat exchanger for the first-fluid, **55** and **58** are heating heat exchangers for adding heat to the first-fluid and may use a second-fluid at the same temperature or at a different temperature as the heating fluid, **54** are vanes within first rotor, **56** are first-fluid nozzles oriented to discharge forwards, **57** is the second rotor, **59** are vanes, **60** is a conduit for the second-fluid, **61**, **62** and **72** are bearings, **64**, **65**, **69** and **70** are entries and exits for the second-fluid, **63** is the second rotor shaft, **71** is first rotor shaft, **66** is the base, while **67** and **68** are the exit and entry points for the first-fluid.

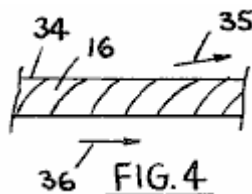
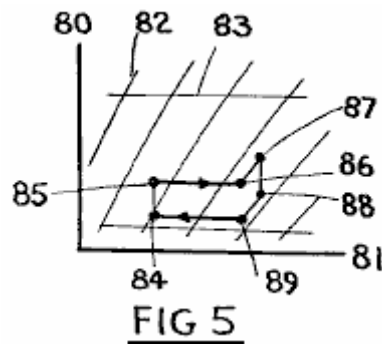

Fig.4 shows a detail of the first-fluid nozzles where **34** is wall on which nozzles **16** are mounted, **35** is the approximate direction of leaving of the first-fluid, and **36** indicates direction of rotation of first rotor.



In **Fig.5**, a pressure-enthalpy diagram for the first fluid is shown, with the working cycle for the first-fluid where **80** is the pressure axis and **81** is enthalpy axis, **82** are constant entropy lines, **83** are constant pressure lines, and for the cycle, compression with heat removal, or without heat removal, occurs from **84** to **85**, heat is added from returning first-fluid from **85** to **86**, further compression is from **86** to **87**, then expansion from **87** to **88** and **89**, and heat removal to the first-fluid from **89** to **84**, thus completing the cycle. Heat is normally added between **87** and **88**, from the second-fluid. The heat addition between **85** and **86**, and heat removal between **89** and **84** may be at constant or varying pressure as desired; pressure may be varied conveniently by increasing or decreasing the diameter of the first-fluid to first-fluid heat exchanger, making the heat exchanger tapered.

In operation, the rotors are filled to a desired pressure with a suitable first-fluid, and the first rotor is caused to rotate. The first-fluid is first compressed with heat removal, and then is passed in heat exchange relationship with the inward bound first-fluid with addition of heat, and after this the first-fluid is further compressed and accelerated and after this compression, the first-fluid is passed via nozzles mounted on the first rotor forwards in the direction of rotation, after which the first fluid enters the second rotor's inward extending passages for deceleration, with heat being added to the first-fluid in the second rotor inward passages for reduction of density of the first-fluid. After passing inwards and decelerating, the first-fluid is passed in heat exchange relationship with the outward bound first-fluid, and after that, the first-fluid may be further decelerated, and then the first-fluid enters the outward extending passages of the first rotor thus completing the cycle.

The operation of the open turbine of **Fig.3** is similar to that described, except that the first-fluid is supplied from external sources, and is then returned to said external source, with cooling then being deleted.

The work input to the first rotor is the work required to accelerate the first-fluid, and the work output by the second rotor is the work of deceleration received by the second rotor. The work output by the turbine is the work differential of these two rotors.

The rotational speed of the second rotor may be higher than the rotational speed of the first rotor. To provide for inward flow of the first fluid within the second rotor, the fluid density is reduced by adding heat to the first fluid either within the second rotor, or also within the first rotor.

The addition of heat from the inward bound first fluid to the outward bound first fluid increases the temperature of the first fluid during latter part of compression and during expansion, and thus has the effect of improving the thermal efficiency of the turbine. Also, another effect is the reduction in the needed rotational speed for the turbine rotors, thus reducing the required strength for the rotors, and making the rotors more economical to make and operate.

Working fluids for this turbine are usually gases for the first-fluid, and liquids for the second and third fluids. Gaseous second and third fluids may be also used, and the first-fluid may be a liquid in some instances. Also, the first fluid may undergo a phase change within the turbine, if so desired, when using a suitable fluid. Applications for this turbine include normal power generation service using various heat sources.

The first rotor shaft and the second rotor shaft are normally connected via a power transmission device so that a part of the power produced by the second rotor is used to rotate the first rotor. Starting of the unit is by a starting device.

The vanes of the rotors may be made curved if desired. In many instances, the first rotor vanes may be curved backward to increase compression of the first-fluid, and the vanes of the second rotor may be also curved, to improve performance, and to suit the design and fluid selected. In this connection, the fins for the heat exchangers are considered to be vanes.

The pressure-enthalpy diagram shown in **Fig.5**, is approximate only. This diagram may be varied, depending of the amount of heat added in the second rotor, or in the first rotor, and depending on the specific location of the second fluid and third fluid heat exchangers. In particular, heat may be added to the first-fluid during expansion to make the first-fluid actually increase in temperature; this will normally improve the overall thermal efficiency of the turbine. Also, heat removal by the third fluid may be conducted in places other than that shown in **Fig.1**, as desired.

It should be also noted that the heat addition to the first-fluid may be from sources other than the second fluid, and similarly, some other means may be used to cool the first-fluid other than the third fluid. Such heating sources may include electricity, or other rotors mounted in proximity to this turbine; these will not change the spirit of this invention.

The heat exchanger mechanism for transferring heat from the inward bound first-fluid to the outward bound first-fluid can also be located within the second rotor, and also the entry and exit for the first-fluid into the turbine may be within the second rotor. Such arrangements are not shown specifically in the drawings since they are considered to be within the capabilities of a skilled designer, in view of the descriptions given herein.

Much of this information on Michael Eskeli is taken, with the kind permission of Scott Robertson, from his web site <http://www.aircaraccess.com> .

James Hardy's Self-Powered Water-jet Generator.

Repeated here from Chapter 2, a device which needs to be in this list of self-powered devices is the ultra simple water-jet generator. There is a video on Google which shows a self-powered electrical water-pump driven, electrical generator at the location: <http://www.youtube.com/watch?v=zlinM1wAl5U>

This is a very simple device where the jet of water from the pump is directed at a simple water-wheel which in turn, spins an electrical alternator, powering both the pump and an electric light bulb, demonstrating free-energy. What is of particular note is the utter simplicity of this device. It uses off-the-shelf parts almost exclusively and can be constructed by almost anyone.

It should be noted that the implementation shown in this video uses the most basic of turbine blades which must have a very low efficiency, and yet the output power generated is well above the level needed to sustain its own operation. Given well shaped conventional turbine blades of much higher efficiency would appear to raise the performance further, while one would think that using a Tesla Turbine with its simple discs should give a really spectacular performance. However, this may very well not be the case as the irregular, pulsed drive of the wheel will be leading-out additional energy as in the case of the Chas Campbell flywheel and the John Bedini flywheel. As it is, with its present form of construction, this device is already capable of producing additional power able to run other pieces of standard mains equipment.



This is clearly a development platform and it would benefit from having the areas which contain water, fully enclosed, and the electrical diversion from mains power to the output alternator operated by a switch.



Initially, the generator is got up to speed, driven by the mains electrical supply. Then, when it is running normally, the mains connection is removed and the motor/generator sustains itself and is also able to power at least one light bulb. The generator output is normal mains current from a standard off-the-shelf alternator. Power generation could hardly get any more simple than this.

The Heat Pump System of Arthur Cahill and John Scott.

Arthur Cahill and John Scott have patented a heat-pump system which draws heat energy from the surrounding environment and uses that energy to produce mechanical and/or electrical energy for powering a household. Why most people have a refrigerator they are generally not aware that it is a heat-pump and moves three times as much heat from inside the refrigerator compared to the necessary input power (COP=3 but could be up to COP=11 when used differently).

This heat-pump system appears to run without any form of energy input, but the energy comes indirectly from the sun heating the surrounding environment and there is no magic involved. Mind you, when the system runs and provides power, generally, without the need for any fuel, the user can be forgiven for

thinking of it as a fuel-less or self-powered system even though strictly speaking, that is not the case. The inventors have made allowances for unusual conditions where environmental conditions can't provide the temperature difference needed to make the system operate as intended. A liquid or gaseous fuel is provided along with a burner to provide the heat difference if those conditions are encountered.

Here is an extract from their patent:

Patent US 4,309,619

5th January 1982

Inventors: Arthur Cahill & John Scott

SOLAR ENERGY SYSTEM

ABSTRACT:

A dynamic, self-sustaining and self-perpetuating device for the production of motive force by combining cryogenic and thermodynamic principles into one system, keeping the systems separated, two open to atmosphere, the other closed, sealed, pressurised and using special compounded fluids, which when alternately exposed to the heat of atmospheric temperature, then, to the coldness of a liquid or air-cooled condenser, first evaporates, then condenses. Rapid expansion during evaporation produces a high pressure vapour which operates an engine and a generator, which are an integral part of the closed system. Rapid condensation drastically reduces back pressure on the aft side of the engine, and the engine operates on the difference between the two pressures, producing electricity, or, the engine can be used as a direct drive for vehicles or equipment. Built-in safeguards and alternatives are a part of the systems, assuring continued operation despite adverse conditions.

US Patent References:

2,969,637	Converting solar to mechanical energy	Jan 1961	Rowekamp
3,495,402	Power system	Feb 1970	Yates
3,995,429	Generating power using environmental temperature differentials	Dec 1976	Peters
4,110,986	Using solar energy carried by a fluid	Sep 1978	Tacchi
4,214,170	Power generation-refrigeration system	Jul 1980	Leonard

BACKGROUND OF THE INVENTION

1. Field of the Invention

This invention relates to a closed-cycle, sealed, pressurised, energy producing system, utilising the sciences of thermodynamics and cryogenics to convert liquid into gas, then back to liquid.

2. Description of the Prior Art

There is no exact prior art, as cryogenics have been used primarily for air conditioning and refrigeration purposes, and thermodynamic efforts have been directed in the area of low efficiency ocean thermal energy conversion systems. A few attempts have been made to combine some form of cryogenics and thermodynamics, without notable success, mainly using sea water for evaporation and condensing. While using no fuel and requiring little in the area of labour, these ocean thermal energy conversion systems are of necessity, low pressure systems and require large sea going platforms to support the huge turbines and heat exchangers which are necessary to produce reasonable electrical power, resulting in excessive capital costs for minimal electrical output, since such stations only have the ability to service a small portion of the populace along the seaboard. None of these contrivances serve or benefit the populace as a whole, while the whole bears the burden of financing through taxes, or government grants.

Proposals to heat gases and cool gases in an endeavour to improve the efficiency of home heating and cooling systems, have been previously advanced, some operating on the heat pump principle. All such previous proposals and inventions have had one thing in common, they all plug into the Utility Company's electric line to obtain the electricity necessary to run the system.

In cryogenics the knowledge that certain liquids, when heated, change into a high pressure vapour, which is the heart of all air conditioning and refrigeration systems, has been known for many years. Thermodynamics were pioneered by the 19th century French physicist Nicholas Carnot. Attempts have been advanced during the years to harness one or the other and sometimes both, for the purpose of heating and cooling, resulting

in the invention of the heat pump in a much earlier year, but none of the systems yet devised for use by the general public have been able to operate without the use of an outside source of electricity, or, fuel, such as oil, or gas fired boilers, resulting in a considerable consumption of fuel and a cataclysmic effect on the earth's environment.

SUMMARY OF THE INVENTION

In accordance with the present invention, the device will operate in hot sunshine; on cloudy days without sunshine; during rainstorms; during snowstorms; during changes in temperature from day to night; during changes in seasons from winter, to spring, to summer, to fall; when it's cold, even below zero; for the power generated is that energy produced when a compounded fluid changes form, first to vapour, then back to liquid, by application of controlled temperatures within the sealed cycle. Thus, by combining cryogenics and thermodynamics into one system, keeping the two separated, one open to atmosphere and the other closed, sealed and pressurised, and by using fluids specifically compounded for the given area, or climate, these fluids, when exposed to atmospheric temperatures, in accordance with the kinetic theories of matter, gases and heat, provide the kinetic energy to operate an engine.

The condenser can be either liquid or air cooled, although for the embodiment depicted herein, the condenser is air cooled.

Generally speaking, there is up to an approximate 2.5 PSI increase associated with each degree of temperature rise in most cryogenic fluids and gases. However, using commercially available fluids, here are a few examples:

Temperature F.	Fluid	Pressure in psi.
125	R-22	280
125	R-500	203
125	R-502	299
125	R-717	293
80	R-13	521
80	R-22	145
80	R-500	102
80	R-502	160
80	R-700	128

You will notice that R-13 at 80° F. produces 521 psi., or 35.4 times atmospheric pressure and at 125° F. would produce thousands of psi. At 95° F. R-22 produces 185 psi., or a thrust on a five inch diameter piston of 3,633.4 pounds. Even at 30° F., with R-22 a thrust of 583.2 pounds is obtained. R-13 at 30° F. produces 263 psi. or 5,112.7 pounds of thrust on a five inch diameter piston. The pressures are there by using the Casco Perpetuating Energy System, utilising proprietary formulated liquids for the area and temperatures to be encountered. It is not intended that any of these mentioned fluids will be used in the present invention; the comparisons being made herein with popular and well known liquids, for comparison purposes only.

THE INVENTION

The present invention relates to a device to supply pollution free power to operate a generator for the producing of electrical power, or, to supply power as a direct drive to a shaft, transmission, clutch, differential or the such, the invention being independent of outside sources of power such as electricity supplied by a Public Utility Company. This is not to be considered perpetual motion, as will be explained later in the text.

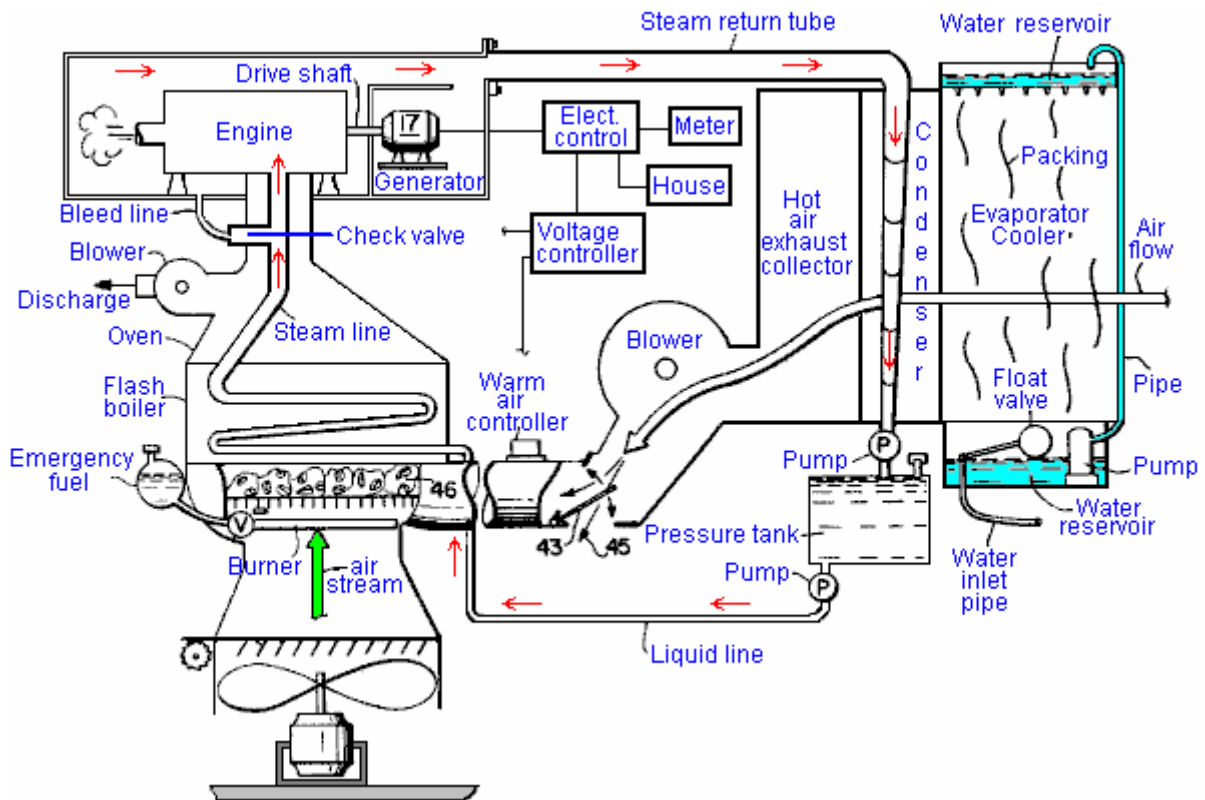

Proprietary liquids, specifically compounded to produce the desired results in a given area, or climate, under pressure in the reservoir to keep them in a liquid state, will, when directed through tubes exposed to atmospheric temperature, change from a liquid state into a gaseous state (from here on referred to as steam), such conversion resulting in tremendous expansion, thus producing high pressure steam with which to drive the engine, or turbine.

It is a general object of this invention to provide a pollution free device for public utilisation, that will produce electrical power or, direct drive power. One object is to produce electrical power with which to heat, cool, cook, run electrical appliances and light a home. Another object of the invention is to provide industry with a pollution free means to not only heat, cool and light factories, but to supply electrical or direct drive power with which to operate factory equipment. A still further object of the invention is to provide a pollution free source of power to propel cars, trains, trucks, buses, equipment, steamships, aeroplanes, and other forms of transportation, without the use of fossil fuels as the primary power source. It is also an object of the present invention to provide the means whereby individuals can produce electrical power for their own use, and as a small power production, sell their surplus electrical power to the local electricity utility company. A further object of the invention is to provide a self-sustaining, small apparatus, that provides ample power from the engine to operate a car or other conveyance, or to supply sufficient electrical power to a home or factory, without having to plug the apparatus into a Public Utility electrical supply.

BRIEF DESCRIPTION OF THE DRAWING

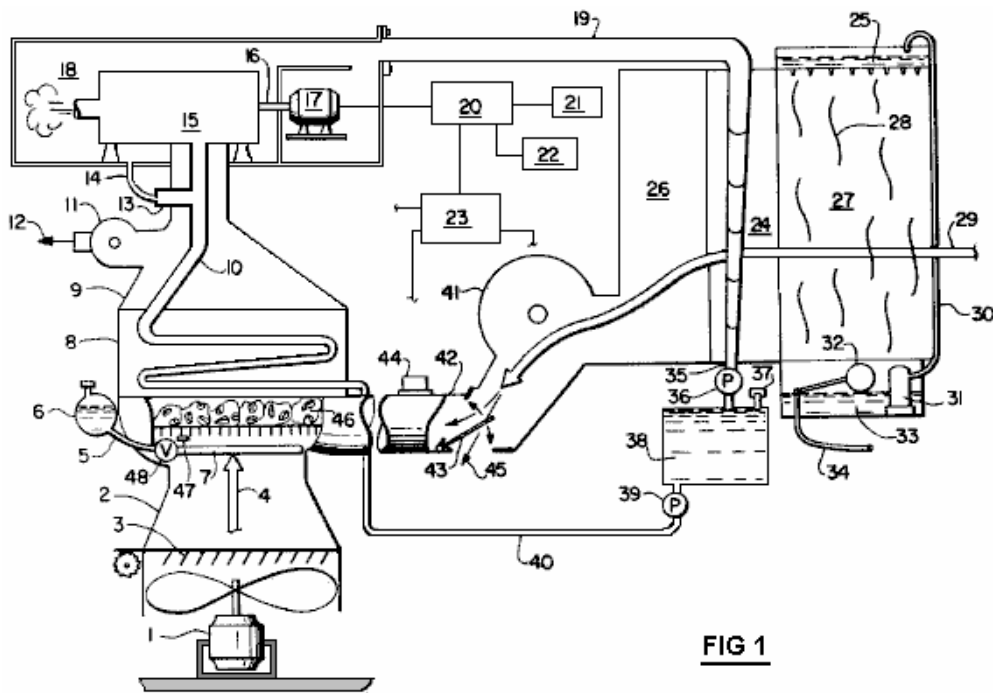

FIG 1

Fig.1 is a partially sectioned schematic view of the system:

DETAILED DESCRIPTION OF A PREFERRED EMBODIMENT

In the drawing, **Fig.1**, the invention is shown in a preferred embodiment for home use. The liquid pump **39**, pumps the cryogenic fluid from the pressurised liquid reservoir **38**, into liquid line **40**, where the fluid gravity feeds into flash boiler **8**. Pump **39** also prevents back pressure from flash boiler **8** from entering the pressurised liquid reservoir **38**, and since the pressure within steam line **10** and liquid line **40** are equal, the cryogenic fluid gravity feeds down liquid line **40** into steam line **10**. The fins on flash boiler **8** are heated to atmospheric temperature by air stream **4**, which converts the fluid within steam line **10**, inside flash boiler **8** into high pressure steam. To maintain the pressure during the passage of steam to the engine **15**, steam line **10** from flash boiler **8** is housed inside the oven **9**, which is exhausted when necessary by discharge **12** from centrifugal blower **11**. Constant temperature within oven **9** and flash boiler **8** is maintained by the admission of fresh atmosphere via air stream **4** passing through the finned flash boiler **8** and up through oven **9**. Centrifugal blower **11** is thermostatically controlled to exhaust air within oven **9** which has cooled below a predetermined temperature. Any excess pressure within steam line **10** is by-passed through check valve **13** and bleed line **14** into the exhaust collector box **18**, thus, a pressurised, closed system is maintained, which, once charged, unless an accident damages or ruptures a line, should not have to be replenished. Pressure within the exhaust collection box **18** will be less than the inlet pressure from steam line **10** to engine **15**, because the condenser **24** is at a lower pressure, as is steam return tube **19**, than PSI input to engine **15** from steam line **10**, thereby creating a suction on the back of the exhaust collector box **18**.

Airstream **29**, which has been cooled by evaporator cooler **27**, flows over the finned surfaces of condenser **24**, instantly lowering the temperature of the steam within condenser **24** below a predetermined condensation point, thus turning the steam back to a liquid, such conversion and instant reduction of volume within condenser **24** causing a pressure reduction at the back of engine **15**. This condensed liquid drains down into liquid coil return **35**, where it is immediately pumped into the pressurised liquid reservoir **38** by liquid pump **36**.

While under pressure in pressurised liquid reservoir **38**, the fluid is maintained in a liquid state regardless of exterior temperature, until it is re-circulated back into the system by liquid pump **39**, through liquid line **40** to flash boiler **8**, where it again converts into steam.

The capacity of evaporator cooler **27** and packing **28** is sufficient to cool intake air stream **29** to a predetermined temperature below atmospheric temperature at any given time, even with humidity rise at night, or during rainstorms, or just during high humidity weather. This temperature differential is maintained as the atmospheric temperature rises and falls, with an anti-freeze liquid being added to the water in the evaporator cooler when temperatures drop below 32° F., to keep it from freezing.

Additional warm air to augment air stream 4 is obtained by directing the warm air exhaust collected in hot exhaust air collector 26, by centrifugal blower 41, through T-assembly 42. Air flow through T-assembly 42 is directed and controlled by the warm air control mechanism 44, which regulates flow-damper 43 to either exhaust through exit 45 into the atmosphere, or alternatively, recirculate air flow 29 through restricted-T 42, thereby compressing and further heating air flow 29 before injecting it through flash boiler 8. Warm air control mechanism 44 also controls fan 1 and louvers 3, selecting the optimum heat from either T-assembly 42 or variable-Venturi 2, to perpetuate the system.

The evaporator cooler 27 has an inlet water pipe 34 which supplies cold water from the normal house water supply, or well, (neither shown). The bottom water reservoir 33 is kept at a constant level of water by float valve 32. The water is pumped by pump 31 up tube 30 into the top water reservoir 25, where it runs through the perforated bottom of reservoir 25 down on to the packing 28, keeping packing 28 constantly wet, which cools air flow 29 as it is drawn through packing 28 and over the fins of condenser 24 by the partial vacuum in the hot air exhaust collector 26, such partial vacuum being created by centrifugal blower 41 exhausting the air from the hot exhaust air collector 26 slightly faster than air flow 29 can replace it.

As long as there is warmer air on the flash boiler 8 side of the system than the cooler condenser 24 side of the system, this device will continue to operate and produce electricity and/or power. The heat recirculating system and the use of three separate, distinct sub-systems within the system, one sealed, permits the system to perpetuate itself. As mentioned above, this device is not to be considered perpetual motion, for somewhere in the ranges of temperature differentials and weather conditions, there may be a no-man's land where the system could shut down, then the variable venturi 2, in conjunction with motor and fan 1 and louvers 3, will come into use automatically upon a signal from warm air controller 44 and 12 voltage controller 23, and be used for a period of time. Motor and fan 1 forces an air stream 4 upward through the variable Venturi 2, with air stream 4 controlled by warm air controller 44 and 12 volt controller 23, adjusting louvers 3. As air stream 4 is forced through the restriction of variable Venturi 2, air stream 4 is compressed as it funnels up the narrowing walls of the variable Venturi 2, such compression causing the air to heat, thus overcoming possible deadlocked or identical temperatures between the condenser 24 and air flow 4. This slight temperature rise in air stream 4 will enable the system to perpetuate itself until the atmospheric temperature itself changes enough to permit a continued operation. Since fan and motor 1 is run by battery power from 12 volt supply 23, even though the batteries are constantly being charged during operation, the batteries may become exhausted because of an extended time the fan and motor 1 are run, then, or, if for any other reason the system starts to run down, a small burner 7, operating on liquid or gaseous fuel 6, through line 5 and valve 48, is ignited by spark mechanism 47 and supplies the heat necessary to support and perpetuate the system until atmospheric temperature and condensing temperature permits the system to operate normally. Fired clay heat retainers 46 are arranged on the grate within burner 7, to retain heat.

The cryogenic system is charged by filling with liquid under pressure through fill pipe 37. Re-charging, if necessary, is done the same way. Engine 15 turns drive shaft 16, which turns generator 17, producing electrical power (110V or 220V) via electric control system 20 which passes the electricity into three channels:

One: To 12-volt controller 23, to run the electrical parts of the system and keep the batteries charged.

Two: To the house 22, to supply the electricity with which to cook, run appliances, light, heat and cool the home.

Three: All remaining electricity is channelled through utility meter 21 into a local utility company's electrical line for sale and use elsewhere.

Patrick Kelly

<http://www.free-energy-info.tuks.nl/>

Chapter 9: Passive Systems

The Devices of Hans Coler.

A German naval captain called Hans Coler invented a COP>1 generator in 1925. He called this device the 'Stromerzeuger' and for a few watts from a dry battery it provided 6 kW continuously. He was refused development support because it was "a perpetual motion machine".

Hans also invented a passive device which he called the 'Magnetstromapparat'. His unit required very careful and slow adjustment to get it operating but when it started it continued on test in a locked room for three months of continuous operation. Nobody, including Hans, seems any too sure how this device works but it is presented here in case you wish to research it further. It comprises six bar magnets wound as shown here. Some are wound in a clockwise direction when looking at the North pole and these are called "Right" those wound in an anticlockwise direction are called "Left":

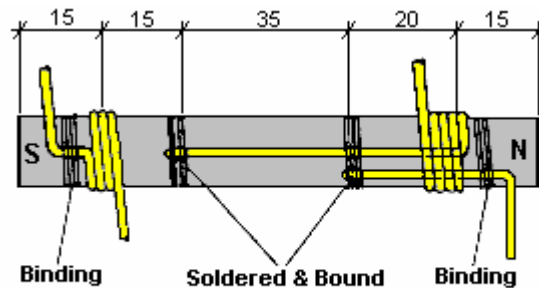

Note: There is paper insulation between magnet and coil

These six magnets are arranged in a hexagon and wired as shown here:

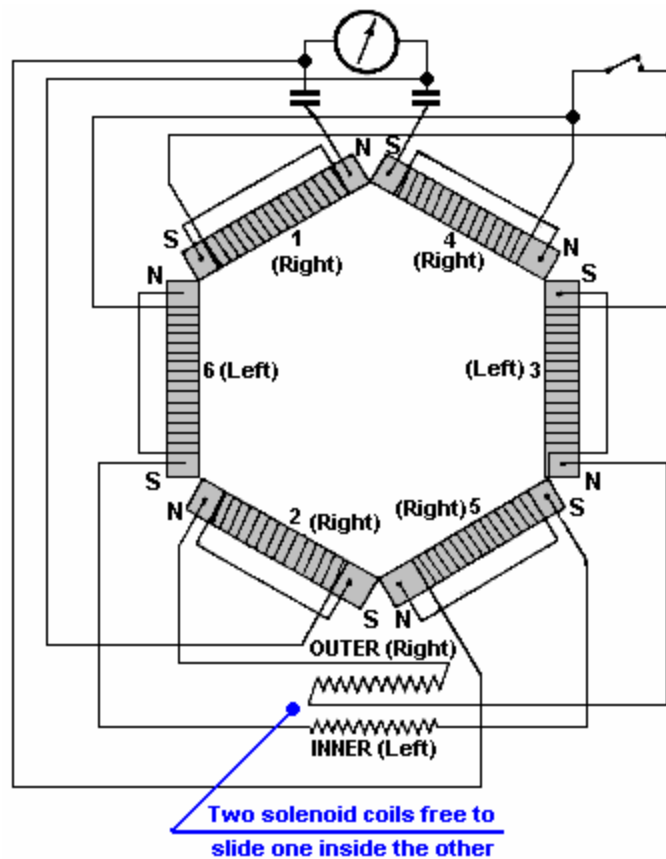

And the schematic diagram is:

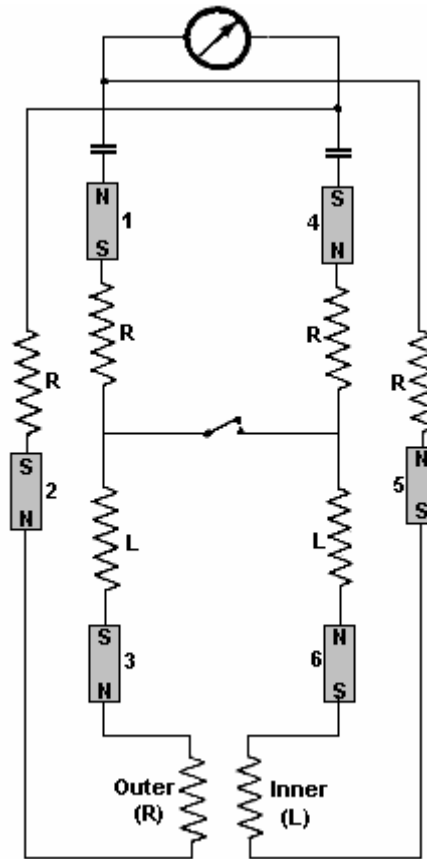

One extremely interesting feature of this passive device is that it has been witnessed producing 450 mV for several hours; it was capable of developing up to 12 Volts. The witnesses were quite sure that it was not picking up radio or mains input. So, what was it picking up? With magnets as the key component, it seems clear that it is the zero-point energy field which is being accessed, but clearly, the access represents a vanishingly small percentage of the actual power available

To operate the device, the switch is left in the open position, the magnets are moved slightly apart and the sliding coil set into various positions with a wait of several minutes between adjustments. The magnets are then separated still further and the coils moved again. This process is repeated until at a critical separation of the magnets, a voltage is developed. The switch is now closed and the process continued more slowly. The voltage then builds up to a maximum which is then maintained indefinitely. The position of the apparatus in the room and the orientation of the device had no effect on the output.

The magnets were selected to be as nearly equal in strength as possible and the resistance of the magnet and coil were checked after winding to make sure they were as nearly equal as possible (about 0.33 ohms).

A very neat construction of the Coler 'Magnetstromapparat' by an unknown German experimenter is shown below - I'm afraid without permission as I have no idea who he is or how to contact him to ask his permission. The quality of workmanship is impressive and the result is a very professional looking device. Notice the sliding coil arrangement at the bottom left with one coil being positioned closely inside another and held in place where the experimenter chooses.

Recently, a construction video has come on offer at <http://www.kohlermagnet.com/> and it shows step by step, one method of implementing this design. The website design screams 'con artist' and the final tuning is shown is such an apparently simple and quick way that it suggests that it could well be faked (by AAA batteries embedded in the underside of the very thick base board and wired in underneath), but the construction instructions make this a video which is worth watching. Scaling up the output from one tiny bulb to kilowatts of power is by no means the simple matter implied in the video, and I personally doubt that a passive device of this type could ever produce kilowatts of output power – at twelve volts you are looking at 165 amps of current requiring copper wire with a diameter of more than 7 mm to carry it.

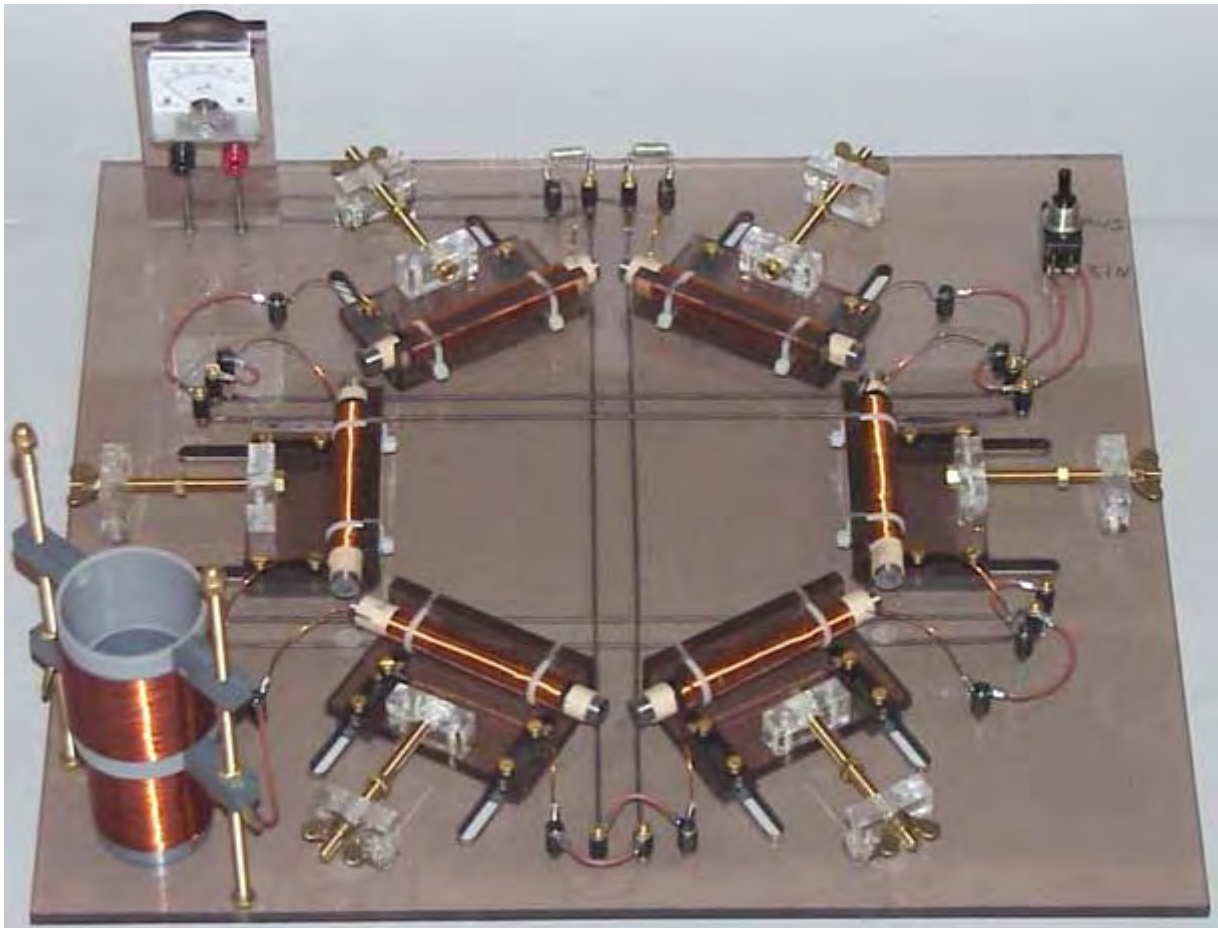

Thomas Trawoeger's Electricity-Producing Pyramid.

One thing which is quite certain, and that is the fact that at this point in time, our technical know-how has not yet encompassed the zero-point energy field properly. It is by no means obvious how the Hans Coler device operates, and if we understood the technology properly, we would be able to say with certainty, exactly how and why it operates, and ways to improve it would be obvious. As it is, all we can do is look at it and wonder, possibly try a few experiments, but the bottom line is that we do not yet understand it. This is the normal situation in the early days of any new field of technology.

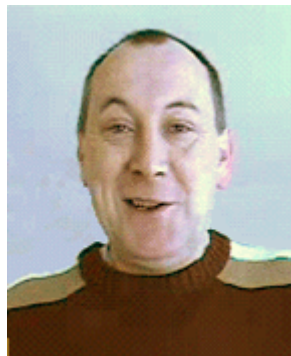

It is also quite usual for pioneers in any new field to encounter a good deal of opposition, mistrust, and generally disheartening treatment from other people. That is certainly the case for Thomas Trawoeger from Austria, who has progressed well in the passive energy field. He has suffered repeated web-based attacks with his display material being destroyed and web sites being made inoperable.

So, what makes some people so afraid of Thomas? The answer is that he is experimenting with shapes. That doesn't sound too terrible does it? Well, it certainly bothers some people, which suggests that he must be on the verge of uncovering a mechanism for drawing serious amounts of power from the zero-point energy field.

Thomas is by no means the first person to examine this area, but he is one of the first to consider drawing serious amounts of electrical energy from the local environment using shape and an appropriate detector. Obviously, this is the same area that Hans Coler was investigating, and it appears that Thomas has managed to tap a continuous 8 watts of electrical energy using a wholly passive device.

As we are not all that familiar with this type of technology, we tend to dismiss it as being a “crackpot” area, not worthy of investigation by serious scientists. It is actually, very far from being that in reality, and it just indicates our serious lack of technical understanding if we dismiss it out of hand. Two hundred years ago, the idea of a television set would definitely have been considered a “crackpot” pipe dream, far, far away from reality. Today, any schoolchild would be horrified at the thought of a TV set being considered “crackpot”. So, what has changed? Only our level of technology, nothing else. In another two hundred years time, when the zero-point energy field is fully understood, people will look back with a smile at the thought of people like us who didn’t know how to draw any amount of energy, freely from the environment, and they will laugh at the thought of burning a fossil fuel to produce energy from a chemical reaction. That, of course, does not help us at all in this time of our ignorance, and we still have to deal with the sort of people who thought that the horse-drawn cart would never be superseded.

The scientific method has been established for a long time now. Essentially, observations are made, experiments are performed and a theory is produced which fits all of the known facts. If additional facts are discovered, then the theory needs to be modified or replaced by another which includes all of the new facts. Established scientists find it difficult to adhere to the scientific principle. They are afraid of losing their reputation, their job or their funding and so are reluctant to investigate any new facts which indicate that some of their best-loved theories need to be revised. Fortunately, not being in the business, we can take new facts on board without any problem. In the light of what certain shapes do, this is just as well.

Let us see if we can put this in perspective. Consider an intelligent, well-educated person living several hundred years ago. Looking skyward at night, he sees the stars. At that time, the theory was that the stars were fixed to a ‘celestial sphere’ which rotates around the Earth. That was a perfectly good theory which matched the known facts of the time. In fact, the concept matches the observed facts so well that some people who teach Astro Navigation to sailors still find it to be useful in teaching the subject today. If you told the average person of those days, that the stars were not very small but very large indeed, that the Earth is orbiting around the Sun and in fact, the Sun is one of those ‘tiny’ stars, then you would have been considered one of the ‘lunatic fringe’.

Next, if you were to tell that person that there were invisible forces passing through the walls of his house and even through him, he would most certainly rate you as a bona fide member of the ‘lunatic fringe’. However, if you then took several compasses into his house and demonstrated that they all pointed in the same direction, he might start to wonder.

Now, just to really establish your membership of the ‘lunatic fringe’ you tell him that one day there will be invisible rays passing through the walls of all buildings and that these rays will allow you to watch things happening on the other side of the world. Finally, to complete the job, you tell him that there is a substance called uranium, and if he were to carry a piece around in his pocket, it would kill him by destroying his body with invisible rays.

Today, school children are aware of, the Solar System, magnetic lines of force, television and X-rays. Further, as the scientific theory has caught up, these children are not considered part of the ‘lunatic fringe’ but this knowledge is expected of them as a matter of course. The only thing which has changed is our understanding of the observed universe.

At the present time, we are faced with a number of observations which do not fit in with the scientific theories of some of the current educational establishments. If we consider these things seriously, we run the risk of being considered part of the ‘lunatic fringe’ until such time as scientific theory catches up with us again. So be it, it is better to examine the facts than to pretend that they don’t exist.

Present theory has worked well enough up to now, but we need to take on board the fact that since it does not cover all of the facts, it needs to be extended or modified. So, what observed facts are causing a problem? Well:

1. In Quantum Mechanics it has been found that some pairs of particles are linked together no matter how far apart they are physically. If you observe the state of one of the pair, the state of the other changes

instantly. This happens far, far faster than the speed of light and that does not fit neatly into present theory.

2. If a substance is cooled down to Absolute Zero temperature, it should be completely motionless, but that is not the case as movement can be observed. This movement is caused by external energy flowing into the frozen material. That energy, observed at Absolute Zero temperature is called 'Zero-Point Energy'. So where does that fit into the theory?
3. There are several devices which are self-powered and which are capable of powering external loads. These things appear to act in defiance to the Law of Conservation of Energy.
4. The Aspden Effect (described below) indicates that current theory does not cover all of the facts.
5. It is now known and fully accepted by science that more than 80% of our universe is composed of matter and energy which we cannot see.
6. Even though our Sun is losing some five tons of mass per second, it radiates more energy than can be accounted for by the fusion of the amount of matter which would cause this loss of mass.
7. The inner core of the Earth is hotter than present theory would expect it to be.

These things indicate that there is something in our universe which is not properly covered by current theory. The present theory thinks of space as being a volume which contains no matter, other than perhaps, a tiny amount of inter-stellar dust. And while space can be traversed by radio waves and many other types of radiation, it is essentially empty.

This concept is definitely not correct. All of the odd observed facts suddenly fit in if we understand that there is an additional field which streams through all of space and passes unnoticed through all matter. This field is composed of particles so tiny that they make an electron appear enormous. These particles may in fact be the 'strings' of String Theory. What is sure, is that this stream of matter contains virtually unlimited energy.

It is the energy seen at Absolute Zero as it is continually streaming in from outside the cold area. It flows to us from every direction and the sun being a major source of it, augments the flow we receive during the daytime. This accounts for the variations seen by T. Henry Moray during the night when the energy he was picking up decreased somewhat.

This matter stream acts like a very dense gas except for the fact that effects in it have effectively zero propagation time. This accounts for the widely separated particles having what appears to be simultaneous reactions to a stimulus. Einstein's idea of the speed of light being an absolute maximum is definitely wrong, as has been demonstrated in the laboratory.

In the early stages of investigating a new field, it can be quite difficult to work out how to approach it, especially if the field is entirely invisible and can't be felt. The same situation was encountered in the early days of magnetism as lines of magnetic force are not visible and cannot be felt. However, when it was observed that iron was affected by magnetism, a mechanism was discovered for displaying where the invisible lines are located, by the use of iron filings. Interestingly, the presence of an iron filing alters the lines of magnetic force in the area as the lines "have a preference for" flowing through the iron. Also, the iron filings used in school demonstrations do not show the actual lines of magnetic force correctly as they themselves become tiny magnets which alter the lines of force which they are supposed to be showing.

We are still in the early stages of investigating the Zero-Point Energy field, so we have to consider anything which has an effect on this invisible field. One observed effect was found by Harold Aspden and has become known as the 'Aspden Effect'. Harold was running tests not related to this subject. He started an electric motor which had a rotor mass of 800 grams and recorded the fact that it took an energy input of 300 joules to bring it up to its running speed of 3,250 revolutions per minute when it was driving no load.

The rotor having a mass of 800 grams and spinning at that speed, its kinetic energy together with that of the drive motor is no more than 15 joules, contrasting with the excessive energy of 300 joules needed to get it rotating at that speed. If the motor is left running for five minutes or more, and then switched off, it comes to rest after a few seconds. But, the motor can then be started again (in the same or opposite direction) and brought up to speed with only 30 joules **provided** that the time lapse between stopping and restarting is no

more than a minute or so. If there is a delay of several minutes, then an energy input of 300 joules is needed to get the rotor spinning again.

This is not a transient heating phenomenon. At all times the bearing housings feel cool and any heating in the drive motor would imply an increase of resistance and a build-up of power to a higher steady state condition. The experimental evidence is that there is something unseen, which is put into motion by the machine rotor. That "something" has an effective mass density 20 times that of the rotor, but it is something that can move independently and its movement can take several minutes to decay, while in contrast, the motor comes to rest in a few seconds.

Two machines of different rotor size and composition reveal the phenomenon and tests indicate variations with time of day and compass orientation of the spin axis. One machine, the one incorporating weaker magnets, showed evidence of gaining magnetic strength during the tests which were repeated over a period of several days.

Nikola Tesla found that uni-directional electric pulses of very short duration (less than one millisecond) cause shockwaves in this medium. These Radiant Energy waves passed through all materials and if they strike any metal object, they generate electrical currents between the metal and ground. Tesla used these waves to light glass globes which had just one metal plate. These lights do not have to be near the source of the Radiant Energy waves. He discovered many other features of these 'longitudinal' waves but one which is of particular interest is that when using his famous Tesla Coil, the waves produced visible streamers which showed what they were doing. What they were doing was running up the outside of the long inner wire coil, not through the wire, mark you, but along the outside of the coil, and when they reached the end of the coil, they continued on out into the air. Interestingly, Tesla believed that this flow of energy "preferred to run along the corrugations of the outside of the coil". That is to say, somewhat like magnetic lines showing a preference for running through iron, this energy field shows a preference for flowing along certain physical shapes.

Thomas Henry Moray developed equipment which could tap up to fifty kilowatts of power from this field. There are two very interesting facts about Moray's demonstrations: Firstly, the valves which he used to interact with the field, had a corrugated cylindrical inner electrode - an interesting shape considering Tesla's opinion on the corrugated outer surface of his coil. Secondly, Moray frequently demonstrated publicly that the power obtained by his equipment could flow uninterrupted through sheet glass while powering light bulbs. Quite apart from demonstrating that the power was definitely not conventional electricity, it is very interesting to note that this power can flow freely through materials. I venture to suggest that Moray's power was not flowing through the wires of his apparatus but rather it was flowing along the outside of the wires, or perhaps more accurately, flowing along near the wires.

Edwin Gray snr. managed to draw large amounts of power from a special tube designed by Marvin Cole. The tube contained a spark gap (like that used by Tesla) and those sparks produced Radiant Energy waves in the Zero-Point Energy field. He managed to collect energy from these waves, very interestingly, by using perforated (or mesh) cylinders of copper surrounding the spark gap. His 80 horsepower electric motor (and/or other equipment such as light bulbs) was powered entirely from energy drawn from the copper cylinders while all of the electrical energy taken from the driving battery was used solely to generate the sparks.

It is very interesting to note that Tesla, Moray and Gray all indicate that corrugated or rough-surface cylinders seem to direct the flow of this energy. Dr Harold Aspden also indicates that once the field is set in motion in any locality, it tends to continue flowing for some time after the influence which is directing it is removed.

Please remember that we are starting to examine a new field of science, and while we know a very limited amount about it at this point in time, at a later date, every schoolchild will be completely familiar with it and find it hard to believe that we knew so little about it, at the start of the twenty-first century. So, at this time, we are trying to understand how energy can be extracted from this newly discovered field. The indications are that the physical shape of some objects can channel this energy.

If you think about it, you suddenly realise that we are already familiar with shape being important in focusing energy. Take the case of a magnifying glass. When the sun is high in the sky, if a magnifying glass is placed in just the right position and turned in just the right direction, then it can start a fire. If the principles behind what is being done are not understood, then the procedure sounds like witchcraft:

1. Make a specially shaped object with curved faces, out of a transparent material

2. Discover the 'focal-length' of the object
3. Wait until Noon
4. Place some kindling on the ground
5. Position the object so that it looks directly at the sun
6. The kindling will catch light without you even having to touch it.

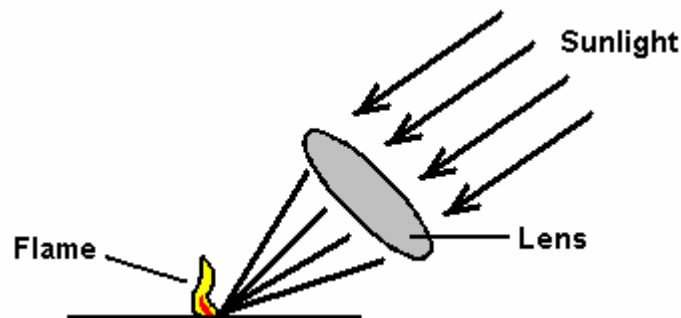

Sounds like something out of a book on magic, doesn't it? Well, you need to know all about that if you want to pass any basic physics examination, and it comes in under the title of "Optics". Please notice that the shape of the lens is vital: it must have a convex face on both sides. Also, the positioning is vital, the lens must be exactly its focal length away from the kindling material: a little too near or a little too far away and it just does not work. Magic? Well it may seem like it, but no, it is just scientific understanding of the nature of radiation from the sun.

Take the case of a satellite dish. This familiar object needs to be an exact shape to work well. It also needs to be made of a material which reflects high-frequency radio waves. Make one out of wood and it will look just the same but it will not work as the TV transmission will pass straight through the wood and not be reflected on to the pick-up sensor connected to the television set.

However, obvious and all as this is, it still did not cut any ice with the patent office in Czechoslovakia on the 4th November 1949. A radio engineer called Karel Drbal turned up with a patent application for a cardboard pyramid shape which kept razor blades sharp and was promptly told to get lost. The patent authorities demanded that he have a theory to show how the device worked. Karel was not particularly put out, and spent years investigating before he determined a theoretical basis for the device. He returned to the patent office, much to the disbelief of the Chief Patent Officer. He was granted his patent, not because his theory was compelling, but because the Chief Patent Officer took a pyramid home and tested it with his own razor blades. When his practical tests confirmed that the pyramid did exactly what Karel claimed, he was granted Patent No. 91304, "Method of Maintaining Razor Blades and the Shape of Straight Razors" and here is a translation:

Republic of Czechoslovakia
Office For Patents And Inventions
Published August, 1959
Patent File Number 91304

The right to use this invention is the property of the State according to Section 3, Paragraph G, Number 34/1957

Karel Drbal, Prague
 Method of Maintaining Razor Blades and the Shape of Straight Razors.

Submitted 4 November, 1949(P2399-49)
 Patent valid from 1 April, 1952

The invention relates to the method of maintaining of razor blades and straight razors sharp without an auxiliary source of energy. To sharpen the blades therefore, no mechanical, thermal, chemical or electrical (from an artificial source) means are being used. There are various mechanical sharpening devices being used up to now, to sharpen used razor blades. The blade is sharpened by crude application of sharpening material, which always results in certain new wear of the blade during the sharpening process. Furthermore, it is known that the influence of an artificial magnetic field improves the sharpening of razor blades and straight razors, if their blades are laid in the direction of the magnetic lines.

According to this invention, the blade is placed in the earth's magnetic field under a hollow pyramid made of dielectric material such as hard paper, paraffin paper, hard cardboard, or some plastic. The pyramid has an opening in its base through which the blade is inserted. This opening can be square, circular, or oval. The most suitable pyramid is a four sided one with a square base, where one side is conveniently equal to the height of the pyramid, multiplied by $\pi / 2$. (which is π or 3.14 / 2). For example, for the height of 10 cm, the side of 15.7 cm is chosen. The razor blade of a straight razor is placed on the support made also of dielectric material, same as the pyramid, or other such as cork, wood, or ceramics, paraffin, paper, etc. Its height is chosen between 1/5 and 1/3 of the height of the pyramid, this support rests also on a plane made of dielectric material. The size of this support should be chosen as to leave the sharp edges free. Its height could vary from the limits stated above. Although it is not absolute necessary, it is recommended that the blade be placed on the support with its sharp edges facing West or East respectively, leaving its side edges as well as its longitudinal axis oriented in the North / South direction. In other words to increase the effectiveness of the device it is recommended lie in essence in the direction of the magnetic lines of the horizontal component of the earth's magnetism. This position improves the performance of the device, it is not however essential for the application of the principle of this invention. After the blade is properly positioned, it is covered by the pyramid placed in such a way that its side walls face North, South, East, and West, while its edges point towards North-West, South-West, South-East, and North-East.

It is beneficial to leave a new blade in the pyramid one to two weeks before using it. It is essential to place it there immediately after the first shave, and not the old, dull one. But it is possible to use an old one, if it is properly resharpened. The blade placed using the method above is left unobstructed until the next shave. The west edge should always face West. It improves the sharpening effect.

Example: When this device was used, 1778 shaves were obtained using 16 razor blades, which is 111 shaves per blade on the average. The brand used was "Dukat Zlato" made in Czechoslovakia. The lowest count was 51, the highest was 200. It is considered very easy to achieve up to 50 shaves on the average. (for a medium hard hair).

The following shows how the invention could save both valuable material and money. One of the razor blades mentioned above, weighs 0.51 grams. We will consider 50 shaves on average when placed in the pyramid against 5 shaves when it is not. It is obvious that the number of shaves, degree of wear, and the ability to regenerate the dull edge depends on the quality of the material, quality of sharpening process, and hardness.given that the numbers are averages and could be in fact much better. In the course of the year one therefore uses 73 razor blades without the aid of the pyramid while only eight razor blades while using the pyramid. The resulting annual saving would be 65 razor blades or 33.15 grams of steel per person.

Only the pyramid shape has been used for this invention, but this invention is not limited to this shape, as it can cover other geometric shapes made of dielectric material that was used in accordance with the invention. And that this shape also causes regeneration of sharp edges of shaving blades by lowering of stresses and reducing the number of defects in the grids of crystal units, in other words recovering and renewing the mechanical and physical properties of the blade.

This is interesting, as it confirms by independent test that a pyramid shape produces an effect, even if it is not possible to say with absolute certainty what exactly the effect is and how exactly the pyramid shape manipulates that energy.

Thomas Trawoeger has produced a video of a pyramid which he constructed. The video commentary is in German and it shows a computer fan being operated when connected to his pyramid which looks like this:



Sceptics will immediately say that as there are wires connected to the device, that the power for the fan is being fed through those wires, even though they appear to be connected to monitoring equipment. This is possible, but in my opinion, it is not actually the case. The pick-up used is shown here:

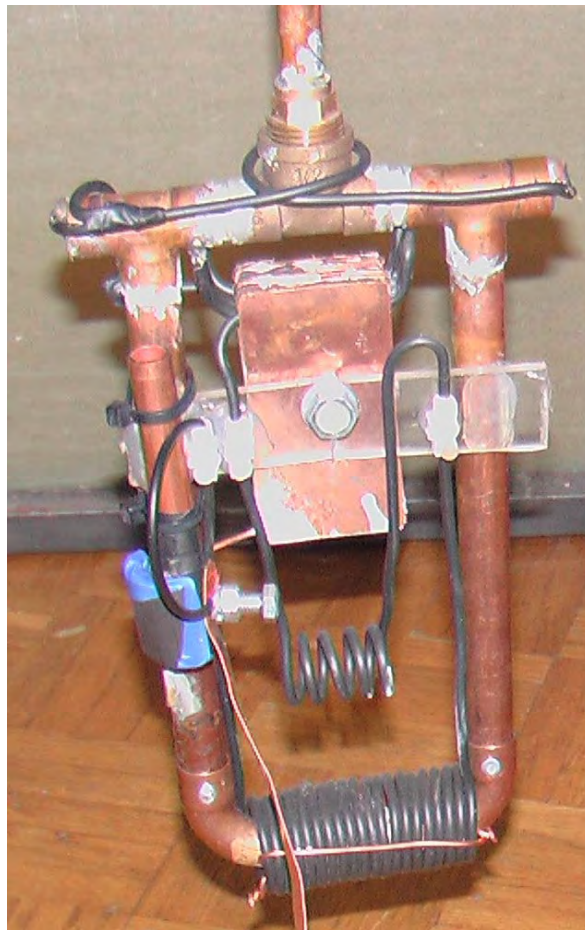

It should be remembered that these pictures are quite old and all inventors keep working on their inventions in an effort to improve their operation and to investigate the effects caused by alterations. At the close of 2007 the design has progressed considerably and now features a number of most unusual things ranging from construction to orientation. The <http://www.overunity.com/index.php/topic,695.300.html> forum is working on replicating this design thanks to the generosity of Thomas Trawoeger who speaks German and the exceptional work of Stefan Hartmann who has produced an English translation and who hosts the web site.

The following is an attempt to present the basic information from that forum in a clear and concise manner, but I recommend that you visit and contribute to the forum if you decide to experiment with this design.

The frame of the pyramid is not the same shape as the well-known Egyptian pyramids and has a sloping face some 5% longer than those in Egypt. The materials used in constructing the pyramid are very important. The frame is made of 20 mm x 20 mm x 2 mm square-section steel tube. While the exact size of the pyramid is not critical, the exact proportions are critical. The base must be exactly square, with each side of the base being exactly the same length, 1 metre in this case. The sloping sides are exactly the same length as the base pieces being 1 metre long also. Eight one-metre lengths of steel section will therefore be needed for building the frame.

The sides of the pyramid need to be covered with a rigid sheet and here again, the material used is critical, with only gypsum/paper boards (plasterboard with no foil) being satisfactory - other materials just don't work. If no sides are added, then the pyramid is very difficult to adjust to get proper operation. When the frame has been constructed, it is positioned in a most unusual way being forty-five degrees away from the conventional positioning of a pyramid. This sets this pyramid so that one pair of corners face North - South, and the frame should be connected to a good electrical ground as shown here:

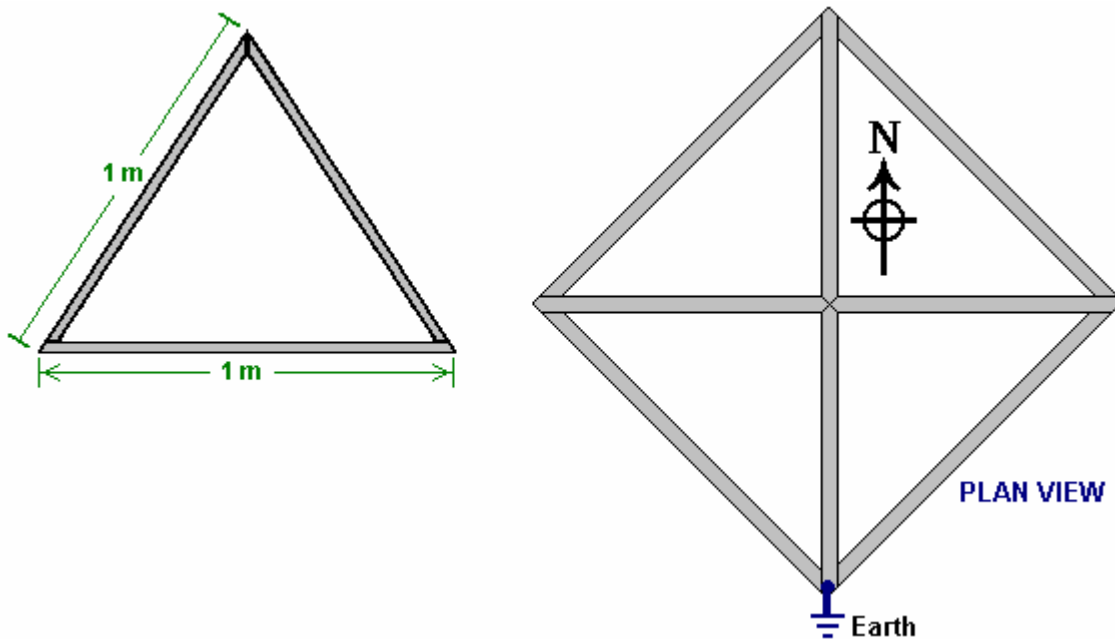

The pick-up is constructed from 12 mm outside diameter copper pipe and fittings and is hard soldered together. It has an overall size of 120 mm x 100 mm hard soldered together as shown here:

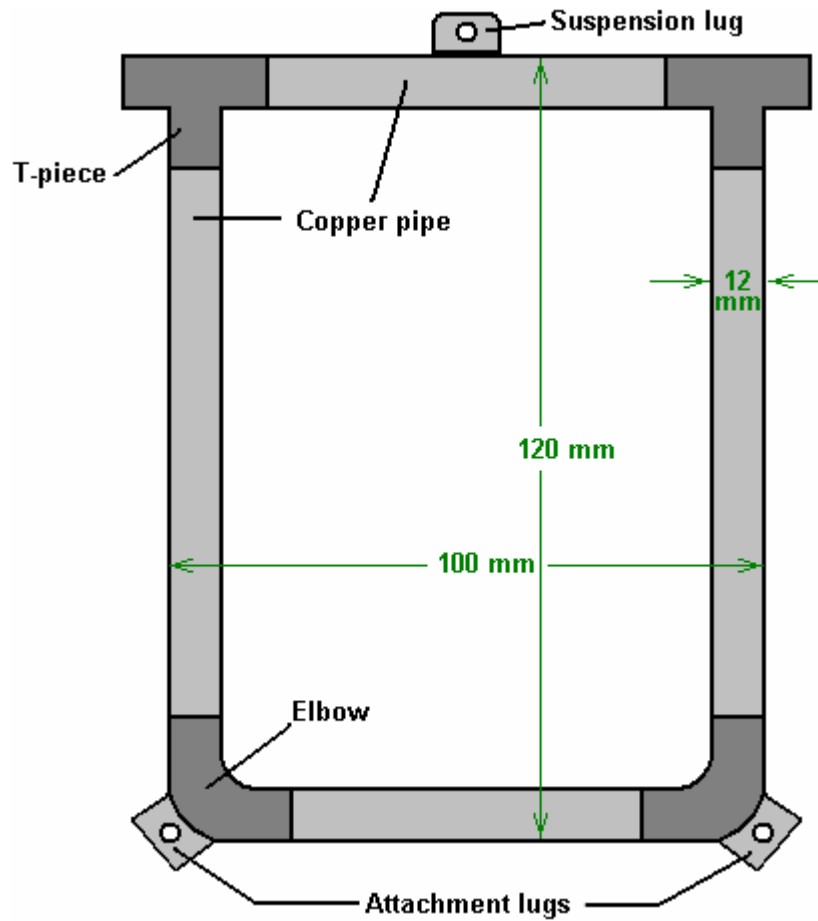

This frame of copper piping is not assembled as shown straight off as there is a requirement for a long graphite rod, 2 to 3 mm in diameter, to be positioned vertically inside each vertical leg of this frame and that can't be done after assembly. So the bottom section is assembled as one piece, and the top section is assembled separately with the graphite rods sticking down out of the T-sections, held in place by their wires and insulating plugs. The graphite rods can be bought from art materials supply shops.

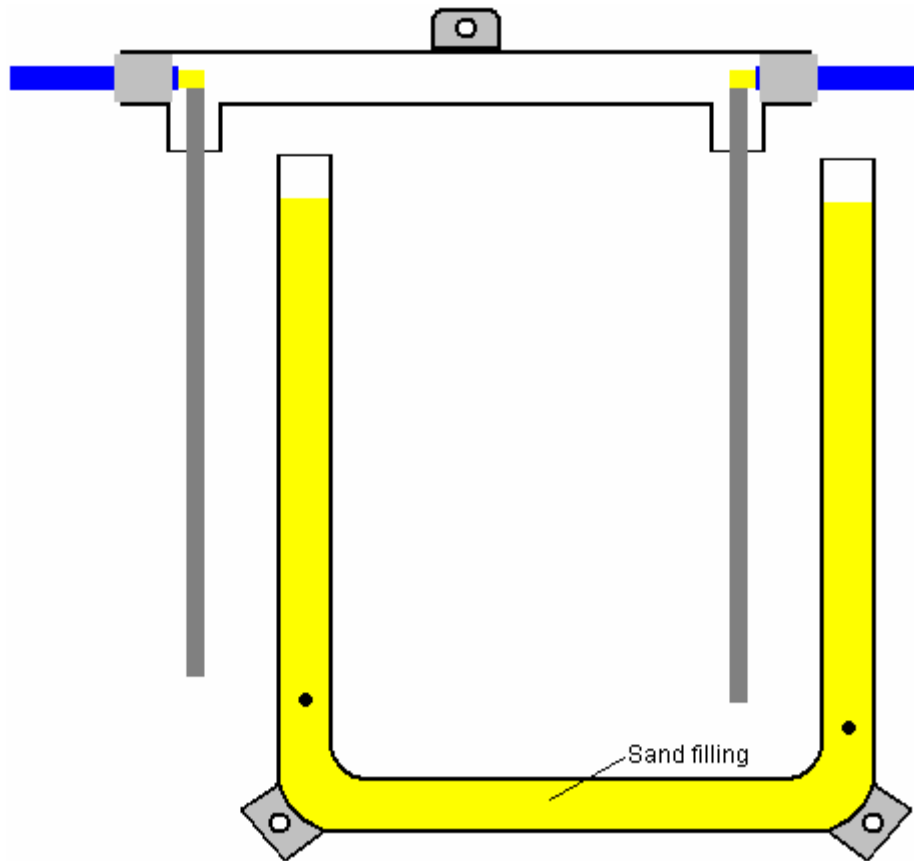

The very fine filter-grade quartz sand filling for the tubes is inserted and the graphite rods carefully positioned so that they do not touch the side walls of the vertical copper tubes, and the two parts joined by hard soldering:

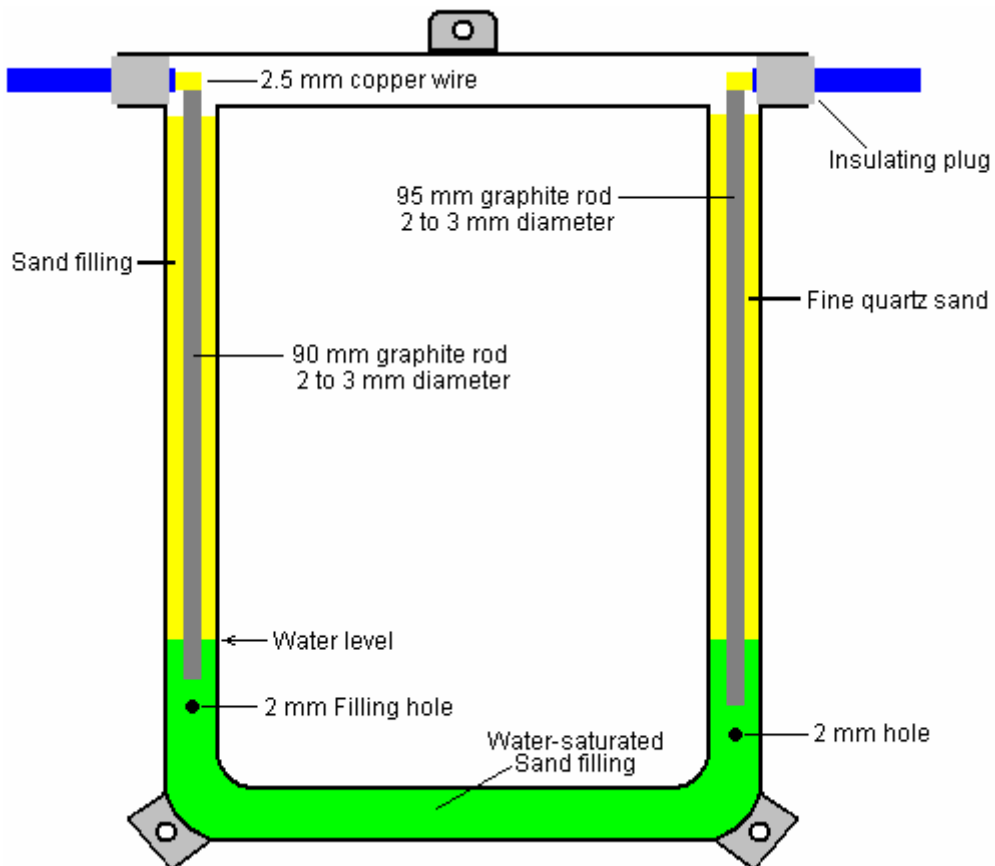

The left hand side hole in the copper pipe is used to inject a 5% salt / water solution, using a hypodermic syringe, until the water starts to come out of the hole at the right hand side. The right hand side hole is 5 mm lower down than the one on the left.

Next, the wires are bent around to produce a 9-turn coil with a 25 mm diameter, around the vertical copper pipes. The windings are in opposite directions on the opposite sides of the frame:

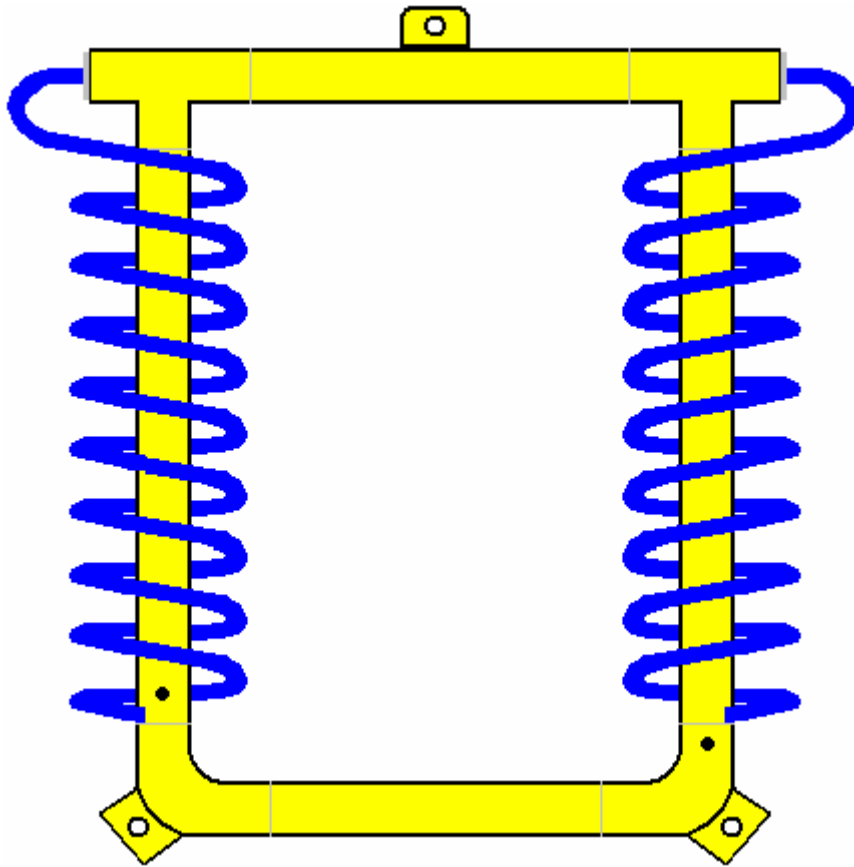

Next, a ten-plate capacitor is made from copper sheets 1 mm thick. As copper is very expensive, the copper plates can be produced from spare lengths of copper pipe, cut along the axis and flattened careful to produce a smooth, unmarked surface 70 mm x 35 mm in size. The plates are stacked and accurately aligned, and a hole is drilled 1 mm off-centre. Then each alternate plate is turned around to produce two sets of plates bolted together with a 6 mm diameter plastic bolt, 1 mm thick plastic washers and a plastic nut. A plastic threaded rod and a plastic nut can be used instead of a plastic bolt. Because the hole is not quite central, the plates stick out at each end, giving clearance for attaching the plates together with the copper wire coming out of the copper pipe framework:

Capacitor Construction

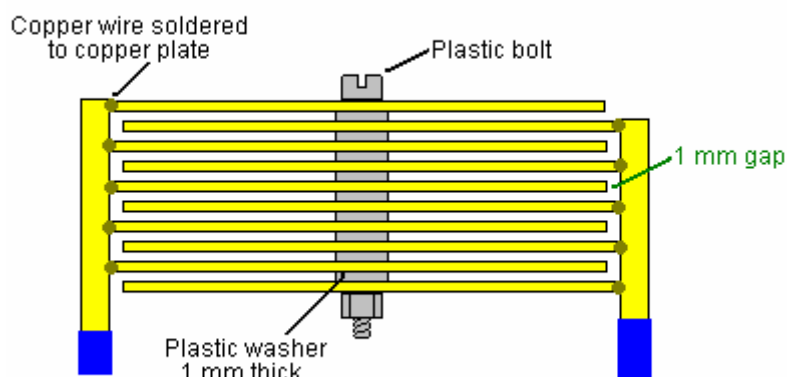

SIDE VIEW

The capacitor is positioned inside the copper pipe frame and held in place by the strength of the 2.5 mm thick copper wire coil around the vertical pipes in the frame:

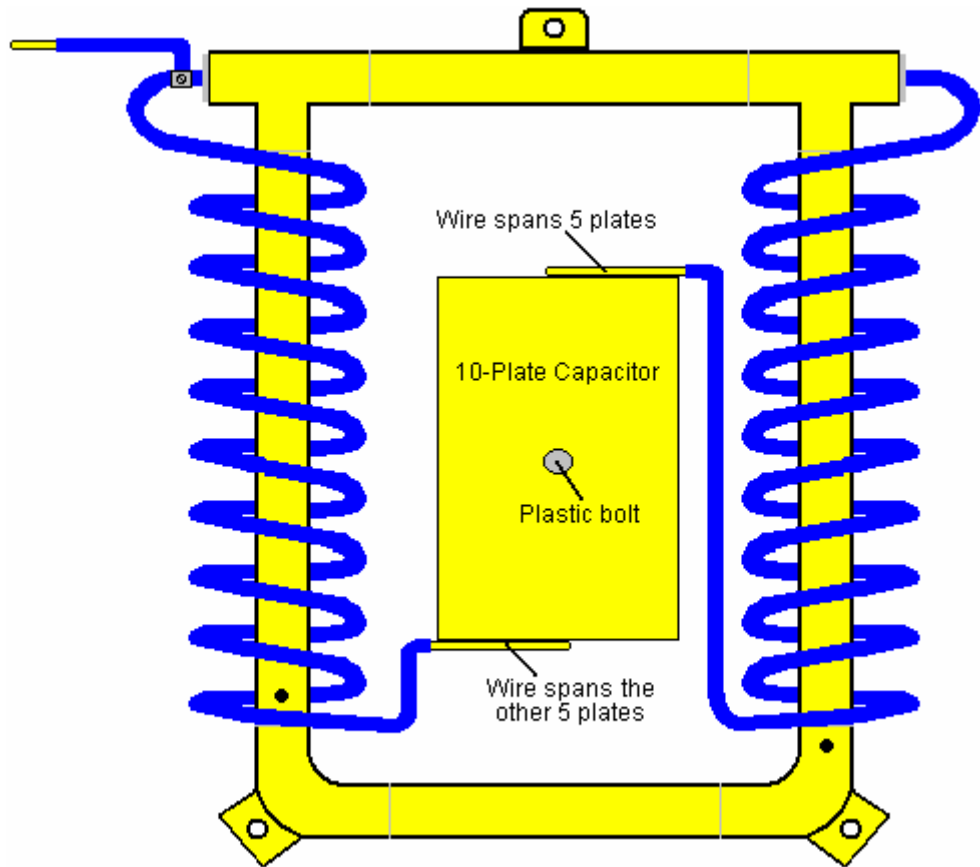

The pick-up sensor is now attached to the pyramid frame. Using a non-conductive cord, it is suspended by the top lug and it's orientation controlled using the lower two lugs. The positioning in the pyramid is unusual, being North-East to South-West, as is shown here:

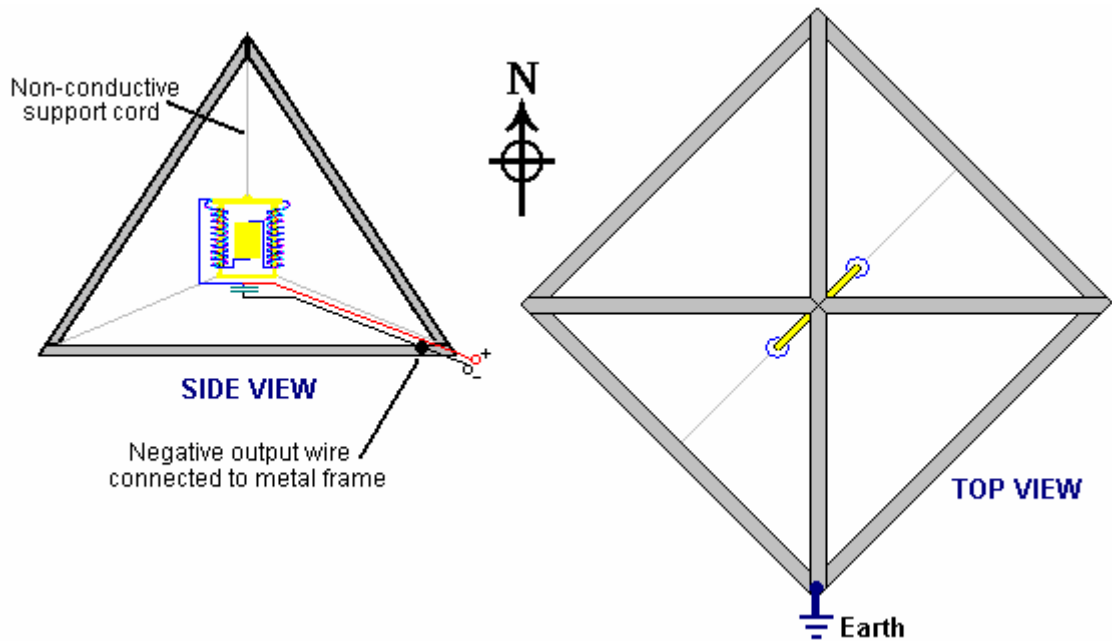

Next, a second capacitor is constructed from 1 mm thick copper sheet. Again, sections of copper pipe can be used after being cut along their long axis and carefully opened out and flattened. This capacitor is just two plates 140 mm x 25 mm spaced 1 mm apart (one inch = 25.4 mm).

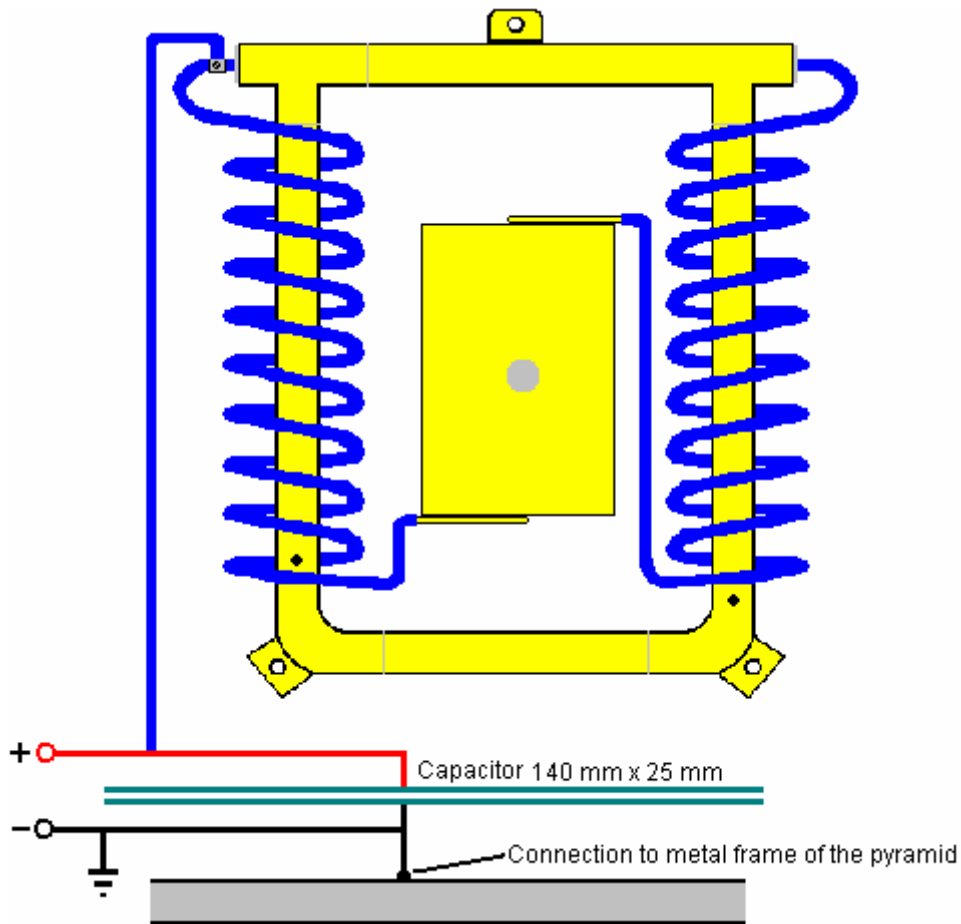

A voltmeter can be used to check the exact alignment of the pyramid. There is a video (with a commentary in German, at http://www.secret.tv/player_popup.php?id=1307723&movieid=1308850 showing an earlier version of this pyramid set-up driving an electrical fan taken from a computer). If this device interests you, then you should join the enthusiast research and development forum mentioned earlier.

In June 2011, Thomas issued instruction videos which show how to construct, use and troubleshoot his newer design of pyramid. These videos are in English and they are very detailed and instructive. One person has split those two very long videos and placed them on YouTube as a series of thirteen smaller videos. In them, he states that the salt water in the design above is actually counter-productive and should not be used.

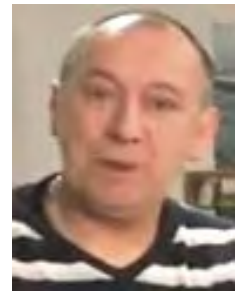

I will not attempt to show the construction details described in those videos as the information is very extensive, but a few comments may be appropriate here. Thomas refers to a 'wheel' but unless I am mistaken, he means a solid plastic rod of circular cross-section. The coil wire which he uses is 1.5 mm diameter copper wire with plastic insulation. With an inner coil of 104 turns, that can produce 1.5 amps at 14 volts, which is 21 watts, and with no input power being provided by the user, that is a COP of infinity. However, if I understand what he is saying, he positions his pyramids North-South (unlike the design above) and more importantly, at a particularly good point on what he calls a 'water-line' which I take to be a ley line located by a dowser. That may be due to the fact that he lives in a village in Austria which is a long way from the Equator, which, according to Joseph Cater's analysis of pyramids, reduces their effectiveness.

In this new design, Thomas uses 20 watts of power from a Citizen's Band radio transmitter, boosted by an amplifier, and applied to his detector tube while he fills it very slowly with fine-grain, high-quality quartz sand. This signal orientates most of the quartz grains and probably replicates most of Thomas Henry Moray's detector which allowed such high power extraction from a simple aerial. In this design of Thomas' no earth wire is needed for operation. An earth wire is provided, but this is for the protection of the user and is not part of the energy gathering system. Thomas agrees with Joseph Cater, that the energy being tapped flows out of the top of the pyramid. One video is located here: <http://www.youtube.com/watch?v=gQvw-ITsvzk>

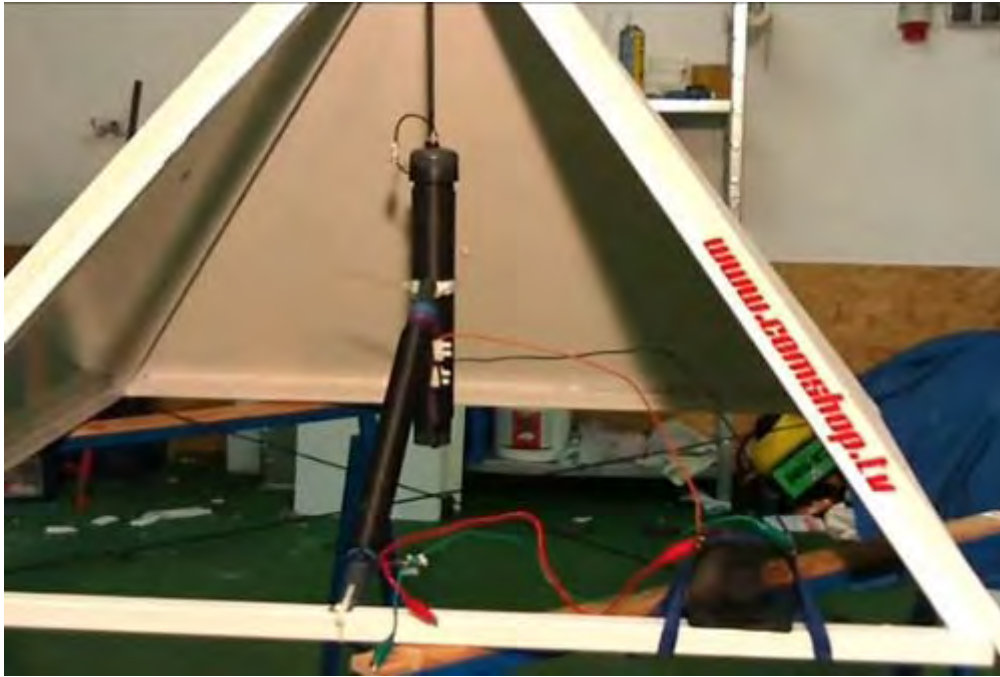

Thomas' website which is in German is <http://www.comshop.tv/>

Thomas picks a fairly small size of pyramid for his demonstration tutorial. It is made using eight pieces of steel channel, each piece being exactly one meter long. He welds these together but remarks that bolting them together is perfectly all right provided that each piece makes good electrical contact with the pieces which it touches as the whole frame acts as a single component in his design.

Thomas also talks about 'welding' the inner copper pipe to one end cap, but what he means is 'soldering' the joint as he spreads resin on the join, heats it with a gas torch and then runs plumber's solder around the join.

Thomas' video series was removed from the web but has been replaced here:

Part 1: <http://www.youtube.com/watch?v=QmngHEhu3wl>

Part 2: <http://www.youtube.com/watch?v=gNrUHLwtqBY>

Part 3: <http://www.youtube.com/watch?v=EBrcFIO20GY>

Part 4: <http://www.youtube.com/watch?v=nTeehORMh0s>

Part 5: <http://www.youtube.com/watch?v=qs1O3YKkMI4>

Part 6: <http://www.youtube.com/watch?v=hiY4TJIIRRs>

Part 7: http://www.youtube.com/watch?v=5MEp08P_vJs

Part 8: http://www.youtube.com/watch?v=PwJK81eW_0k

Part 9: <http://www.youtube.com/watch?v=ohzxjmhv3W0>

Part 10: <http://www.youtube.com/watch?v=u0LQRJbi240>

Part 11: <http://www.youtube.com/watch?v=2MFRRHuv5S8>

Part 12: <http://www.youtube.com/watch?v=WkVd3viiQCU>

Part 13: <http://www.youtube.com/watch?v=QLqUwM-PTok>

* * * * *

Antoine Bovis' Discoveries.

Confirmation of the dehydrating effect of a pyramid was provided by the Frenchman Antoine Bovis who went on holiday to Egypt in the 1930s and visited the Great Pyramid which was constructed exactly in the North - South direction (almost certainly not by accident) and built to an accuracy of 0.01% or better. He discovered that a number of small animals had wandered into the pyramid, got lost and starved to death. The really interesting point was that all of these animals had been mummified through dehydration and none of the bodies had rotted away. When he returned home, he built a model pyramid with base edges three feet long. He found that his pyramid duplicated the dehydration effect. He, and others who followed him, investigated the effect of pyramids. They found:

1. The best shape is that which matches the dimensions of the Great Pyramid, whose faces slope at an angle of 51 degrees, 51 minutes and 10 seconds. Pyramids with other slopes will work, but not quite as well. If you would like to make one yourself and test the effects, then each of the four sides can be cut from stiff cardboard to these proportions:

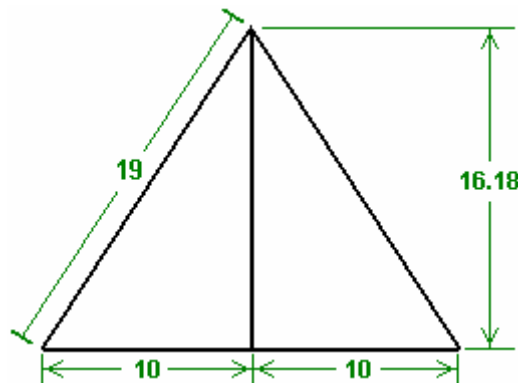

So if the base length is to be 20 units, then the height at the mid point of the base will be 16.18 units.
 If the base length is to be 25 units (mm, cm, inches, or whatever), then the height should be 20.22 units.
 If the total base width is to be 30 units, then the height at it's mid point should be 24.27 units.
 If the total base width is to be 35 units, then the height should be 28.32 units, and so on.
 The right-angled triangles formed have a height of 1.618 (the "golden ratio") times the base width.

Just cut out four of the triangles and tape the edges together. It would be a good idea to add a square base piece (or triangular gussets) to ensure that the base is exactly square and not skewed.

Thomas Trawoeger states that the exact angle is not particularly important and his latest designs have angles of about sixty degrees.

2. There is no need for the pyramid faces to be solid, provided that there are four base sides and four sloping edges. Having solid sloping faces gives a slight improvement and Thomas considers that at least three of the sloping faces should have panels, the material type being important..

If building a framework pyramid, then the dimensions for the four base pieces and the four sloping edges would be:

- Base: 20, length of the sloping edges: 19
- Base: 25, length of the sloping edges: 23.76
- Base: 30, length of the sloping edges: 28.52
- Base: 35, length of the sloping edges: 33.27 and so on.

3. The best material from which to construct the pyramid is copper, but as it tends to be rather expensive, almost any other material can be used: plastic piping, timber laths, steel alloy pipes, wire, etc. Giving the pyramid a sheet-copper cap which runs down about 5% of the face length, giving a short solid face on the open framework also gives a slight improvement. Les Brown states that the best material is sheet iron plated with gold, though that sounds very expensive.

So, what can a pyramid do? Well, nothing, actually, except for directing and possibly concentrating and focusing the Zero-Point Energy field. Perhaps the question should be 'what effects are caused by using a pyramid?'

Well, as seen above, Flavio Thomas Trawoeger has managed to get a continuous electrical output via a pyramid for a period of at least thirty days. I understand that he uses a magnet just as an on-off switch, but having a magnet as part of the pick-up makes a lot of sense as the magnetic dipole of any magnet has a distinct effect on the zero-point energy field. The low-tech investigators have noted that an effect caused by a pyramid may be repeated for maybe nine times in a row, and then inexplicably, one day it will not work. They surmise that the effect may be caused by magnetic variations due to solar flares or the like. They may well be right in this as they are not using a magnet but just simple cardboard, or more frequently, simple frame pyramids. This area is wide open to investigation with very low-tech apparatus and passive electronic components.

What has been found repeatedly:

James Brock's Experiments.

1. Living things placed under a pyramid shape are boosted in health and growth. You can test this easily for yourself by taking two identical plants or animals and keeping one under a pyramid and one outside the pyramid. An example of this is given on the website:

<http://www.motheearthnews.com/Sustainable-Farming/1977-11-01/Raising-Rabbits.aspx> where James Brock of Texas reports on tests he has run on a group of rabbits. It would be incredibly easy to fake this kind of information, so you need to make up your own mind on the validity, and ideally, run some simple tests of your own. James states that he built a pyramid-shaped hutch with 4-foot long sloping edges out of timber, and a rectangular hutch:



Each of the hutches had a transparent door. He then borrowed eight rabbits aged about 20 days old, taken from two different litters and placed them in matched groups of four in each hutch, and fed them equally, weighing them every four days.

By the end of the experiment, 57 days later, the rabbits which had been housed in the pyramid hutch weighed an average of 46.5 ounces, compared to an average of 34.5 ounces for those in the rectangular hutch. That is, the rabbits in the pyramid hutch were nearly 35% heavier and side by side they looked like this:



James presents the results like this:

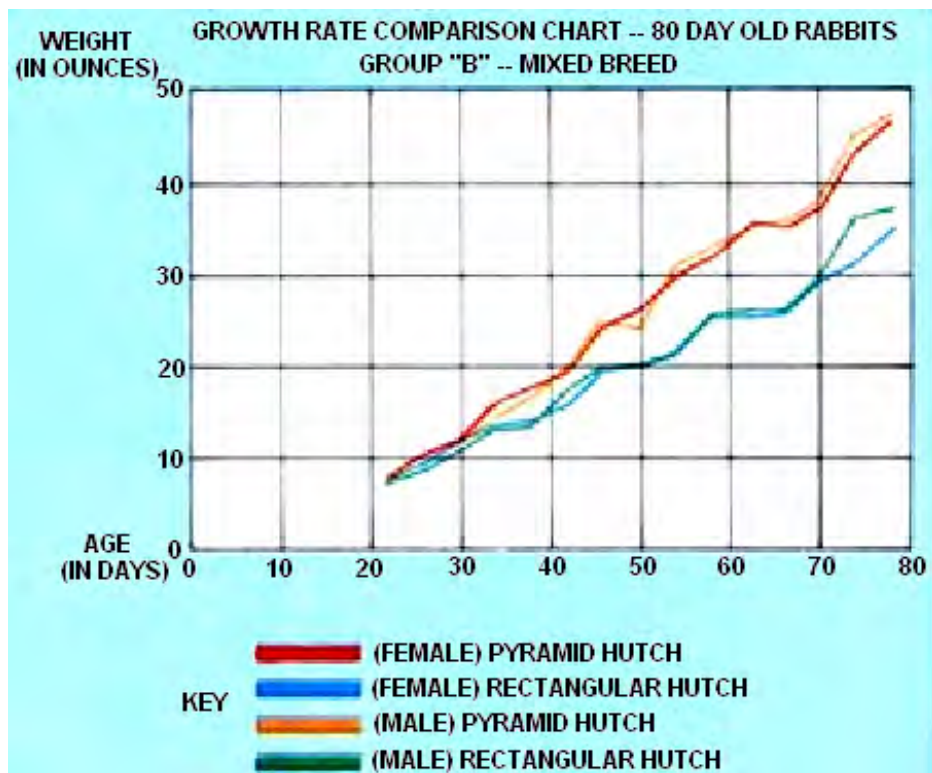
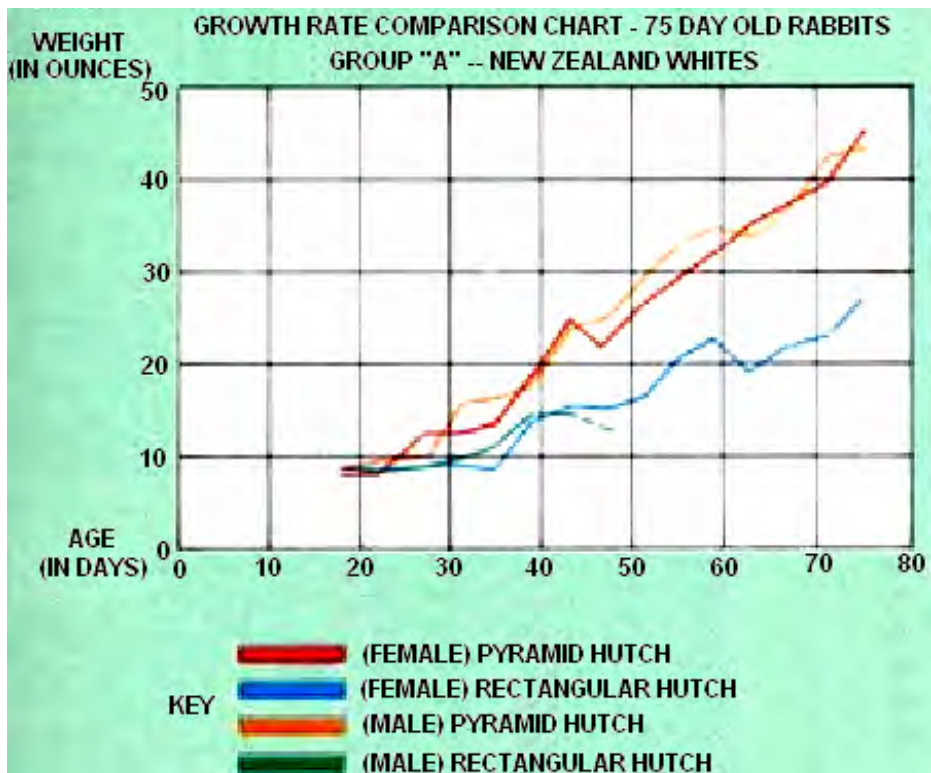

James invites you to run this test for yourself to verify that this does indeed occur. It should be noted that as the test ran over a period of 57 days, any days lost through magnetic variation would not have been detected by him.

2. Pyramid users also state that they find the following effects on a consistent basis (provided that the pyramid is kept away from strong electromagnetic fields, so do not put a pyramid on top of a TV set or a refrigerator):

- (a) Fruit is preserved. When a purchase of fresh fruit or vegetables is made, if they are placed under a pyramid for about an hour and then stored as they normally would, it is said that they stay fresh for at least twice as long as normal and the flavour is enhanced. It is believed that unhelpful micro-organisms are killed by the pyramid. If the fruit and vegetables are kept indefinitely under the pyramid they eventually dry up instead of rotting.
- (b) Food quality is enhanced. If frozen meat, fish or fowl is thawed out under a pyramid, the quality of the meat is said to be noticeably improved.
- (c) Coffee quality is improved. If a cup of coffee is left under a pyramid for about twenty minutes, it is said to gain a much more mellow flavour. Leaving ground coffee or a jar of instant coffee under a pyramid over night is also said to change it so the coffee made from it is of a much higher quality.
- (d) A glass of wine placed under a pyramid for twenty minutes is said to undergo a distinct change with great improvement seen in both the taste and the aroma. Other alcoholic drinks are also said to be improved by this process.
- (e) A twenty to thirty minute treatment of fruit juices is said to reduce the acidic "bite" of the drink, and in many cases, alter the colour of the juice.
- (f) Any item pickled in vinegar, such as olives and pickles, gain a greatly enhanced natural flavour and are greatly mellowed by the process.
- (g) The rapid growth of mould on Cheddar cheese can be overcome by the cheese being kept under a pyramid at normal room temperature. It is recommended that the cheese be wrapped in plastic to reduce the rate at which it dries out.
- (h) Rice and wheat can be kept in open jars under a (twelve-inch open frame wire) pyramid for at least four months without any form of deterioration or infestation by insects or flies - which are repelled by the energy inside the pyramid. A test was run outdoors with a six-foot base pyramid with food placed in the centre to attract ants. It was found that ants heading for the food followed a curved path out of the pyramid without ever reaching the food.
- (i) Water left under a pyramid is altered. Cut flowers placed in it tend to last 30% longer than normal while growing plants watered with it grow more strongly and are hardier. The water appears to hold the energy indefinitely, a glassful takes twenty minutes, a quart (two pints) takes one hour and larger amounts should be left over night. Animals given the choice of pyramid water or untreated water almost always choose the treated water.

3. In the 1940s, Verne Cameron of America discovered that the beneficial pyramid energy could be transmitted. He placed a pyramid at each end of a row of plants, connected a wire to the apex of each pyramid and ran the wire underneath the plants. He placed a clump of steel wool on the wire under each plant. The pyramids were, aligned North--South and he found that even better results were obtained if the row of plants was also aligned in a North--South direction.

4. There are reports of instances where dogs suffering from old age, lameness and hair loss have been cured and rejuvenated in about six weeks by the use of a pyramid.

I suggest that the Great Pyramid in Egypt was most definitely not built as a burial place but that the chamber inside it was used to treat people with large amounts of the energy picked up by the shape of the pyramid. It is also likely that the pyramid was used as a communications device, but that is outside the scope of this document.

The really important thing is that there is clearly an energy field (perhaps the ZPE field) which flows continuously, is very beneficial to life and which can be tapped to produce unlimited motive power without the need for any kind of input from us. Just like the early discovery days of radio waves, TV signals, X-rays, Gamma rays, etc. we are in the discovery days of the Zero-Point Energy field. You, personally, have as much chance of being successful in harnessing this energy as any large research laboratory with unlimited financial resources. Remember that Flavio Thomas can drive an electrical fan using equipment which costs next to nothing. A cone shape with the same face slope as a pyramid is also an effective shape, and no matter how you position it, it always has a face pointing North--South. May I also remark that it might be worth experimenting with the "pancake" coil (called a bi-filar series-connected coil) patented by Tesla because he found that it was particularly effective in picking up Zero-Point Energy:

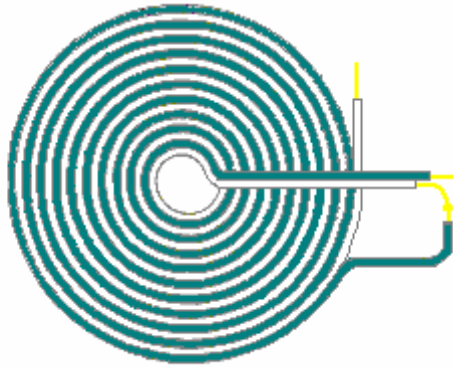

Flat 'pancake' coil winding method patented by Nikola Tesla

The Patent of Peter Grandics.

Other people have also investigated pyramid and cone shapes and they confirm that there is indeed a considerable effect from these shapes. Peter Grandics has been awarded US patent 6,974,110 for the collection of electrical energy from a pyramid shape. He tested the system both with an applied high voltage and without any applied voltage, and discovered electrical pick-up in both cases. Here is a digest of part of his patent:

SUMMARY OF THE INVENTION

This invention describes a simple technique to convert the energy of a DC electrostatic field into an alternating current by wrapping a coil around a pyramid. The resulting AC current can be rectified and used for practical purposes. A pyramid-shaped capacitor can also be used in an inverse mode of operation for the generation of propulsive force.

Accordingly, one embodiment of the present invention is a method for converting DC electrostatic energy into usable electrical energy, the method comprising the steps of:

- (1) Providing a capacitor of pyramidal shape;
- (2) Placing an insulated coil on the surface of the capacitor, the coil having leads;
- (3) Attaching a rectifier to the leads of the coil, the rectifier having leads; and
- (4) Attaching a capacitor or a battery to the leads of the rectifier so that DC electrostatic energy is converted into usable electrical energy.

DESCRIPTION OF THE PREFERRED EMBODIMENT

This invention describes a novel method is of converting DC electrostatic energy into an AC current which can be rectified and used for practical purposes. The shape of the capacitor and the body of such device is designed to convert the DC electrostatic energy into the AC current for maximum effect.

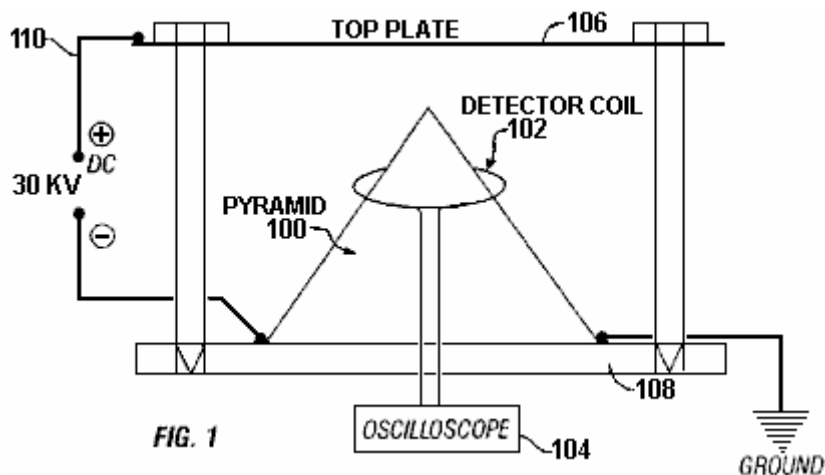

A pyramidal or conical shape is preferred for one of the capacitor electrodes. In **Fig.1**, a detector coil **102** is provided that which connected to an oscilloscope **104**. The coil surrounds the metallic pyramid **100**. In the experimental set-up shown, the field is established between a top plate **106** and the pyramid **100** by using a ground **108** connected to a source of DC electrical energy **110**. When a high voltage DC field (30 kV) is established on such capacitor, a regularly repeating, clock-like signal is detected in the coil placed on the pyramid's surface (**Fig.2**). This is an unexpected observation as corona discharges are irregular by nature.

The alternating current from the coil can be rectified and used for practical purposes. If a suitable DC electrostatic field could be found in nature, this principle would be useful in tapping the energy of such field. To test for this possibility, I have measured the rectified signal from the coil without an external power source. The rectified coil output was collected in a capacitor and voltage measured at intervals of one hour. The voltage measured is significantly higher if the capacitor electrode is pyramid-shaped as opposed to a box-shaped electrode of the same height and volume. When the pyramid is placed inside a Faraday cage, the signal is excluded (see details in the Example). The data have demonstrated in principle that with this experimental set-up, electrical energy can be extracted from the Earth's electrostatic field. The Earth's surface and the ionosphere substitutes for the two charged electrodes, which exhibit negative and positive polarities, respectively.

EXAMPLE 1

Demonstration of the pyramid generator: For the experiments, I have selected a one-foot base length foam pyramid from a pyramid vendor (The Pyramid Project, Ft. Wayne, Ind.). The outside of the pyramid was covered with aluminium foil. The pyramid was placed on a 2 foot x 2 foot insulating polyethylene platform equipped with an adjustable height 2 foot x 2 foot size aluminium top plate, 1/16" thick. The height of the aluminium plate was adjusted as needed and a gap of 1.25" between the plate and the tip of the pyramid was used in the experiments. In some experiments, an aluminium pyramid was used with a wall thickness of 1/16".

A high voltage (HV) CRT power source producing 30 kV DC was taken from a colour monitor. I have assumed that an actual energy-producing pyramid should be relatively high in order to obtain a large voltage drop from its tip to the ground. Therefore, assuming a height of 100-150 m for a life-size pyramid and a voltage drop of 200-300 V/m near the surface of the Earth, the 30 kV is in the range of the voltage-drop expected for the height of a life-size pyramid.

The positive pole was attached to the top aluminium plate. This simulated the positive charge of the atmosphere. One corner of the pyramid was attached to the negative pole of the high voltage power source, while the opposite corner of the pyramid was grounded. This set-up served as a model for the electrostatic field distribution around a potential life-sized pyramid. As controls, either a 1 foot x 1 foot sheet of aluminium foil or an aluminium foil-covered box, having the main dimensions of the test pyramid (1' x 1' x 7.625"), was used as a negative pole. The detector coils were made by winding 20 turns of 24 gauge enamel-coated magnet wire, approximately 8 cm in diameter. A Tektronix high-frequency oscilloscope, Model no. 2236 was used for signal analysis.

The first sets of experiments were control measurements with a box of the same height and base length as the test pyramid. The detector coil was placed on the top of the box. Measurements were taken with or without the high voltage applied. One corner of the box was attached to the HV power source (negative pole) and the opposite corner to the ground. The same arrangement was used for the flat square (1'x1') foil. The peak-to-peak signal amplitude for the box was 8 mV and the signal frequency was 2 MHz. For the flat foil sheet, the signal amplitude was 12 mV with a frequency of 1.43 MHz. The signal form was of a decaying sine wave.

When high voltage was applied to these shapes, signal amplitude of 14 mV was obtained for the flat sheet and of 16 mV for the box. The signal frequency was 1.54 MHz for the flat sheet and 2 MHz for the box. The waveforms were of decaying sine waves in all these experiments.

When the pyramid was tested without HV, the peak-to-peak signal amplitude was measured at 60 mV with a frequency of 2 MHz. When the high voltage was applied, the signal amplitude increased up to 180-200 mV, while the frequency remained at 2 MHz. The pyramid produced signal intensity significantly higher than the controls. The signal is regularly repeating, clock-like in nature (**Fig.2**). When a metal (aluminium) pyramid of the same size (wall thickness 1/16" inch) was tested in the same high voltage field using the same detection coil, a voltage of 1 to 1.5 V was detected at the frequency of 2 MHz.

To collect energy from the coil, a bridge rectifier (1000 V peak voltage at 6 A) was attached to the leads of the coil. The rectified current was fed into a capacitor (1500 microfarad, 250 V DC max.), and a direct current of 45 V was obtained. This has demonstrated a simple method to convert electrostatic energy into a continuous direct current. An 8-turn coil having an output of 200-300 V AC (peak-to-peak) was also used for energy conversion. The rectified current from the 8-turn coil powered a 0.186 W light bulb (**Fig.3**). Ideally, the bridge rectifier is made of fast-recovery diodes.

Even in the absence of an externally applied voltage, current is always present in the circuit. Charge builds up in the capacitor and 1 V was obtained overnight using the 20-turn coil set-up. Over 48 hours, a voltage of 5 V was measured. Faraday shielding practically prevented the phenomenon.

The preferred shape of the pyramid as a charge collector was again demonstrated in further experiments using the 8-turn coil-bridge rectifier-capacitor (1,500 microfarad) assembly placed on the 1 ft base length aluminium pyramid. A same-volume and height aluminium box was used as control. Charging times of 1-2 hours were used under fair-weather conditions. For the pyramid, 550 mV was measured on the capacitor while on the box 100 mV was obtained. This demonstrated the superiority of the pyramidal shape in capturing atmospheric electrostatic energy. It also demonstrated that we could tap into the electrostatic field of the atmosphere and draw electric energy. For the collection of energy, a battery could substitute for the capacitor.

You should also check out the pyramid aspects of the cutting-edge work of Paulo and Alexandra Correa as detailed in Chapter 11.

The Pyramids of Les Brown.

Les Brown experimented extensively with pyramids and related devices. It should be stressed at this point that while various facts have been observed, the action caused by a pyramid is not fully understood at this time and no "laws" have yet been deduced. We have to work here on the basis of "this is what was done, and these are the results". Because of this, the following extract from the work of the late Les Brown is reproduced here and you must decide for yourself if what he says is true and whether or not it might be worth your while trying out some of what he says:



In conducting pyramid experiments you should look daily for signs of change and note them meticulously, and above all be patient. Don't plant a seed one day and expect to have a plant six feet high the next. A plant takes just as long to develop inside a pyramid as it does outside, but in time you will see the tremendous difference in size. Also, don't keep moving plants around inside your pyramid during an experiment; leave pots stationary so you can see what the results are.

Here, you will see how to make your own pyramids for experimentation; they can be constructed entirely from inexpensive materials equally as well as from costly ones. Cardboard, wire, plywood or anything rigid enough to retain the pyramid shape will suffice. The pyramid does not necessarily have to be solid; in many experiments just the outline shape is sufficient, provided that it is jointed at all corners and at the apex.

An "energiser" array of small pyramids can be made from cardboard and positioned at the corners of a large pyramid to enhance its operation. An array might have 5 rows of four little pyramids or perhaps twelve rows of six pyramids. Individual small pyramids can be made from cardboard and then assembled on a base to form the array. The following template could be used for this, just ensure that the base is square:

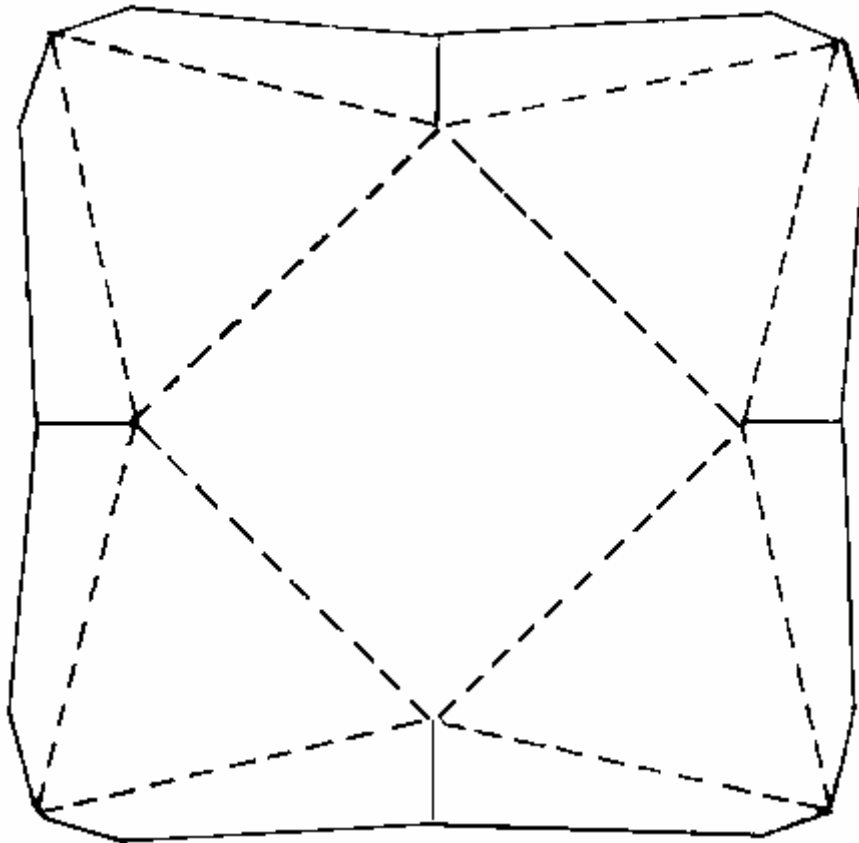

A pyramid energizer has multiple uses. The one shown above consists of 72 small cardboard pyramids and a top plate of cardboard covered with foil. By placing the top plate on top of the pyramids and orienting the entire energizer to magnetic north, you can use the energy generated for such purposes as mummification, energizing water, or as a beneficial surface on which to place growing plants for outstanding growth.

Remember that with all types of pyramids, positioning is all-important. One of the sloping sides must at all times be facing towards magnetic North - not a corner but the flat face of the pyramid must face **magnetic** North. Use a compass to determine the direction of magnetic north which will be nearly in line with the Pole star, (but not quite). In this respect, a pyramid is like a radio. For maximum performance you must tune it in properly, pointing it right at the transmitter. Similarly, several pyramids with one face towards magnetic North and stacked on top of each other will produce increased energy, cell activity and growth.

Using pyramids, I sincerely believe that I can grow 36 times more and better plants in a given area than any farmer or market gardener can in the same area, using conventional methods.

All kinds of shapes contain energy, the very nature of the shape itself determines the degree of energy which it contains, that is, the shape determines how receptive it will be to energy flows. By shapes I refer mainly to cubes, spheres, triangles, pyramids and the like. Each shape has potential, but they all have different limits

and we should seek the one which offers the most potential. Of all shapes, the pyramid gives us the best performance because it receives the greatest amount of energy. It must be four-sided, of specific measurements and correct angles, and it must have the correct compass orientation. There are dangers in using a pyramid blindly without knowledge of its functions and its great potential. When all four sides are put together you must have a pyramid which is leaning in at 51 degrees, 51 minutes, 14 seconds.

The energy inside the pyramid is said to come down through the peak and continues coming in until it reaches a certain intensity, or the limits of safety, at which point the pyramid releases all the energy and begins collecting it again. The pyramid is said to release 80% of its energy through the peak and the other 20% via the four base corners. Only a pyramid performs this way, and even then the maximum performance is obtained only by a perfect pyramid. So, when you start to build one, aim at perfection. The nearer you can get to a perfect pyramid, the more you will benefit.

You can grow bumper crops with the use of a pyramid. Anything growing beside an iron fence will be bigger and better than one nowhere near metal. The reason is that the iron fence picks up static or magnetic energy and feeds it to the plant. I remember my mother and grandmother placing large nails in the soil of their potted house plants because plants thus treated always grew bigger and better. They had no idea why. In fact, if you asked them, the standard answer was that, as the nail rusted, the plant fed on it. This reasoning is fallible, however, because for one thing, plants can only absorb minerals in liquid form and for another, the rust would kill some plants. Rather, the nails picked up the magnetic energy and boosted the house plants' growth. When a plant receives an extra dose of energy to that already floating free in the atmosphere, that dose acts as a stimulant and causes better growth. What really happens is that the living cells are increased in size, and naturally when each cell is larger, since there are still the same number of cells, the final plant is a lot larger than normal.

If you grow a plant in a pyramid, it absorbs energy at a much higher intensity than that produced by the nails in the plant pots, and so the end result is enormous growth. When this is applied to vegetables and fruits, the plants, as well as their products, are immensely oversized. My own experiments have convinced me that this energy creates a special reaction in living cells of plants, resulting in larger blooms, leaves and fruits on whatever plants are propagated within the pyramid.

The normal life cycle of lettuce, for instance, from seed to maturity, is six to eight weeks. Grown under a pyramid the life cycle is still the same, but the plant is considerably larger. If one allows the vine type of tomato to mature to six or seven trusses under a pyramid while simultaneously allowing an identical plant to do the same outside the pyramid, giving both plants precisely the same feeding and watering, a startling difference in yield occurs. I should mention that if you put your outside plant too near the pyramid, it will reach for, and receive, some of the pyramid's energy, so keep it well away to get a fair test. The outside tomatoes would weigh out at approximately 10 to 14 pounds per plant, whereas the plant grown in the pyramid would produce between 50 and 60 pounds of tomatoes. Not every type of plant grown under a pyramid will produce this increase; this is the average that I have come to expect from tomatoes.

A few more averages I have obtained repeatedly were: lettuce two to three times larger than average; beans 25 inches long by 1.25 inches wide; cabbage - when controls were three pounds each, the pyramid-grown plants were 12 to 13 pounds per head; radishes that normally would be the size of a quarter were four inches in diameter; controlled cucumbers that averaged 14 inches in length and weighed up to one pound normally, were 21 inches long and weighed up to four pounds when grown in the pyramid and the pyramid also warms your whole house and cleanses the air which you breathe.

Energised air in the pyramid also appears to repel small insects; though, there is no need for pesticides to be used within its glass walls. Pest-free plants grow to maturity inside, with none of the setbacks plants subject to normal attack from pests suffer in the garden outside. This also means that pyramid-grown vegetables need no washing upon harvesting. The mere appearance of such plants is more appetising than that of those grown normally. Greens are more vivid, and many leaves have a sheen which is noticeably absent from plants in kitchen gardens. Artificial fertilisers will never be used in my pyramid. Since many fertilisers apparently are becoming short in supply themselves, the ability to grow plants without their use is a double blessing for all mankind. I will use natural farmyard manures, the best way to regain the succulent taste and nutrition which are missing from plants grown with chemical fertilisers.

An egg broken out of its shell and left within the confines of the pyramid will gradually congeal and become like plastic, as the interior energy works on its cells - harmlessly. The cells do not die nor induce putrefaction. After a period of even weeks or months these congealed eggs can be reconstituted in water to

the point where they can be eaten with complete safety, and they taste even more delicious than eggs produced in the usual way.

One peculiar phenomenon which I have observed under my large pyramid is the formation of dew on the plants inside it. This happens early in the morning. During all my years of experience with greenhouses, I never noticed dew forming on any plants in conventional greenhouses. This dew gently dissipates as the sun grows stronger, exactly as it would outside. Also, after a recent thunderstorm, my pyramid cucumbers grew two to two and a half inches in a matter of a few hours.

I built a pyramid purely for research purposes. For large-scale production, one which is much greater in size would be needed. When building the prototype, I encountered and overcame, virtually all the problems one can expect to meet in a construction of this type. Building a pyramid is nothing like building a house, and while a slight difference in measurements can be overcome when building a house, it is not possible to make a mistake in a pyramid and just carry on building. The particular piece containing the error must be pulled out and replaced correctly, as any mistake is transferred all the way around the pyramid.

My test pyramid is 30 feet high along a perpendicular line from ground to peak. The sides from base corner to peak measure 44 feet 4.5 inches, with a baseline of 46 feet 10.5 inches. It contains two additional floors above the ground level, and the sum of the areas of these two floors equals or is greater than that of the ground floor. Thus, the two additional floors virtually double the growing area. My first floor is 12 feet above the ground, and there is a reason for this. I calculated that when the sun was at its highest point the first floor would have to be positioned at 12-feet high so as to allow the sun to shine on to the back north edge of the ground floor. The 12-foot height was perfect, its achievement resulting from a mixture of good judgement and a bit of luck. However, I would not need to build a growing level at this height again because there are as many plants that grow well in shade as there are those that prefer growing in the sun. In future, my floors will all be eight feet apart, and I will put my sun-loving plants in the southern half and my shade-loving ones in the back northern half.

By placing the floors at eight-foot intervals there is much more growing area available than there is in placing the first floor at a 12-foot height. In addition, choosing this lower height allows the upper floors to decrease more slowly in size than they would if placed farther apart. Obviously, as the peak of the pyramid is approached, the floors decrease in area. One of the benefits obtained with these extra floors is that since heat rises, there are higher temperatures on each floor nearer the top of the pyramid. This allows a wide range of crops to be grown.

To illustrate the temperature difference, if the ground floor were 75° F, then the second floor would reach a temperature of 90° F, and the third floor would be around 105° F to 115° F, each floor having higher humidity. This means that anything from cool to tropical crops can be grown within one pyramid. The ground floor is perfect for such crops as radishes, lettuce, carrots, beets, tomatoes, etc., while the second floor is ideal for cucumbers, squash, peppers, and plants which like it hotter and more humid than the first floor. The top floor can be used for lemons, oranges, figs and especially, orchids.

The pyramid draws in its own water on the ground floor; I have never had to water that level being built directly on the ground. It never draws too much or too little water, always just the right amount for growth. Naturally, I have to pump water to the upper floors, but because the first floor provides its own water supply, at least half of my pyramid is watered for nothing automatically. I grow right in the ground the pyramid stands on, but upstairs I have placed wooden planting troughs all around the floors, leaving room to walk, and I grow plants in these. It is a major job getting the soil to the upper floors initially, but it is only a one-time task. The troughs are 16 inches deep and 14 inches wide, and contain a bottom. There is a run all around the edge of each of the upper floors and another inside, leaving enough room to work, with a gap on each side allowing passage from one run to the other.

Space in the pyramid is used to the utmost. At the perimeter of the low areas, I plant the kind of plants that need little headroom, and then plant bigger crops toward the middle. This is a matter of common sense, but using vine type tomatoes and stringing them up, one can work between the rows better, and if the lower leaves are removed, there is sufficient space to grow lettuce, cabbage or any low-lying crop in between the tomato plants. The trusses may be left on the tomatoes; they will not shade the low-lying plants. To ensure a steady supply of food, it is wise to plant only a few plants of each variety at intervals, which means that in the beginning it will take several weeks to reap a full harvest, but subsequently there will be a continuous yield.

By planting in such a manner, the grower will reap about six full crops each year. This method applies only to an enclosed pyramid, which would also require heating in the winter. The means of heating is up to the individual. Personally, I use a wood stove because I have my own wood supply. However, a wood and oil combination is best because it allows one to be away for a couple of days when necessary. If the wood fire gets low, then the oil burner takes over.

As for growing potentials of the floors of the pyramid, I have found that the second floor is the best place for germinating new seeds. I find that I can get germination in three days on that floor, whereas it usually takes five days otherwise. Thus far I have described the pyramid from the growing aspect only to the point of showing you how and where to grow crops, but let's take a look at a few statistics on production. Your garden, for instance, will only give one crop a year, but the pyramid through the means I suggest will give you six crops per year. Now let's compare two pieces of ground, both the same size, one with a pyramid on it. Say the garden is 50 feet square and the pyramid is 50 feet square. The upper floors inside the pyramid give you approximately 2,500 square feet of growing area upstairs to go along with your ground floor area of 2,500 square feet, and you are getting six crops per floor as opposed to one, or twice times six, the equivalent of 12 times your garden yield. Nor is that all of the advantage. Recall my discussion of the increase in size of the plant cells; this itself gives an average of three times the size of a normal crop. Multiplying the 12 times by the size of the crop, you are 36 times better off than with a single garden.

In addition to food growth, the pyramid also has application in food preservation. I have read statistics stating that 40 percent of all food grown in my home country of Canada is lost to putrefaction, whether at the place of storage, in transport, in wholesale and retail, or finally in the home. Regardless of how this spoilage occurs, this state of affairs can be remedied. The energy of the pyramid which grows plants so amazingly well, can also be used for the purpose of mummification of food, which can be dehydrated and kept in storage for an indefinite period without losing any of its taste or nutritional properties. There are absolutely no ill effects on any food stored in a pyramid. In fact, in many instances it is far better when reconstituted than it was in the first place. It has the water taken out of it; but it also repels bacteria and as a result, nothing will rot in a pyramid. For instance, I cannot make a compost heap inside my pyramid; I have to do it outside; otherwise the ingredients in the compost all remain in good shape and will not break down. For further proof, the grain grown in Manitoba today is a direct descendant of the grain found in the Great Pyramid, grain that had been there for centuries and had kept perfectly.

Earlier I mentioned mummifying eggs. I conducted an experiment in mummifying an egg, using a pyramid energizer instead of a single wire pyramid. The energizer consisted of a small batch of one-inch-high pyramids, 20 in all, positioned in a group. Using such a grid of pyramids provides quicker results than using just one pyramid. I broke an egg into a dish, placed the dish on top of the energizer and observed what happened in the ensuing days. In about six hours I noticed the lower perimeter of the yolk turning a pale yellow, and this continued through each day, the pale colour gradually moving up to the top of the yolk. In the meantime, the white was becoming less fluid, thickening, so to speak. In two weeks the whole egg was just like glass; the yolk was hard and the white was now in crystal form. At no time would flies or any insect approach it, even though it was open to them. Flies were as prevalent as usually, but they would not go near the egg. There was never any smell present from start to finish.

I left the egg in this state for about three months and showed it to many of my visitors, but then it was time to reconstitute it and try it for taste. I added some water (an egg loses about 30 grams of water in such a period) and left it 24 hours. I then boiled some water with the intention of poaching the egg. When the water was ready, I tipped the egg in, and immediately the albumen turned snowy white and the yolk a perfectly natural yellow colour. Had I dropped the egg before reconstituting it, it would have shattered, but now it was simmering away, looking just like a fresh egg. After cooking the egg I put it on a plate, salted and peppered it, then cut the yolk through with my knife, and it flooded across my plate. I admit I was not in too big a hurry to eat it, but if I was going to prove something, I had to taste it. I smelled the egg, and it was no different from normal, so I ate it. I can honestly say it was one of the nicest eggs I have ever tasted; it seemed to have more flavour than usual.

I do not know of any food that cannot be treated in such a manner. I have tried preserving every food I can think of, and it all keeps indefinitely, with no refrigeration necessary.



Egg processed in a glass ashtray

Since publicity was first given to my large, wooden pyramid some three years ago, I have been inundated with letters, phone calls and personal visits. People from all walks of life and many different places in North America and Europe and indeed a few from further afield - Australia, Africa and the East Indies - all have expressed an interest and have given me kind encouragement. Many of these letters, calls and visits have had as their objective the gathering of practical information on the building of pyramids and the problems likely to be encountered.

My pyramid is made from rough sawn timber, cut on and near my own property and milled by a neighbour. But it is not necessary for pyramids to be made of wood. They can be made of any rigid material which will support permanent glazing: cardboard, strong wire, sheet steel or metal, angle irons, logs - anything which will not curve and that can be precisely measured and fitted.

Nor do pyramids have to be solid for many uses; open-sided shapes will do, so long as all corners are joined and the angles are correct. My present pyramid is made of timber and covered with heavy-gauge plastic sheet. Future ones will be sheathed in fibreglass, acrylic or glass. They will be closed pyramids solely because I propose to grow food during the depths of Canada's frigid winters.

My pyramid frame is built mainly of wood measuring two inches by four inches and two inches by eight inches rough sawn (not planed all over). Pyramids can be built to any scale as long as the proportions are correct.

There is a video of Les Brown on the web at this time. It shows him describing some of his experiences with pyramids. It is at <http://www.youtube.com/watch?v=P7VN6B2GjVI> and in it, Les describes an experiment which he carried out on his very large agricultural pyramid. First, he constructed a helical coil using co-axial cable which he sketches this way:



The coil was then placed on a 1/4" (6 mm) thick sheet of plywood and the end of the wire in the centre of the coil was inserted through the plywood and the central conductor pushed into the ground. The other end of the wire was bent up to act as an aerial, and the board itself was stapled through with two inch long wire staples driven into the ground and acting as further grounding for the coil, as he sketched here:

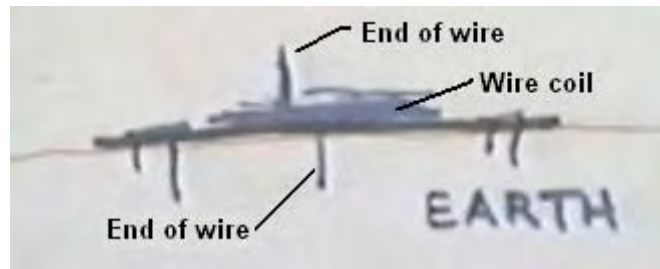

Les then climbed up a ladder and fastened another coil under the apex of the pyramid. This coil he wound out of multi-stranded copper wire. The wound it in the shape of an inverted cone with the wire going in a counter-clockwise direction and he spread the top strands out like an aerial array. He drew it this way:

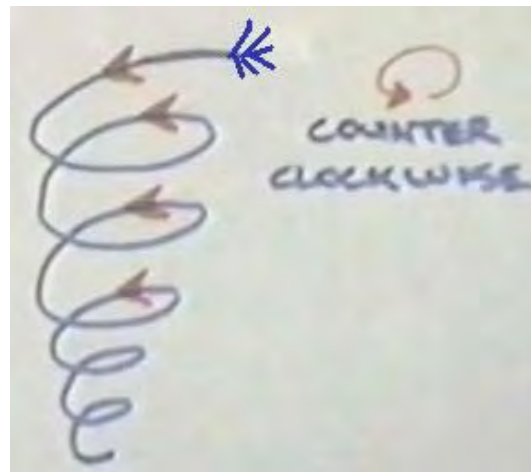

He then decided to connect the two coils together using a strand of natural wool, so he tied it to the bottom of the coil at the apex. He climbed down the ladder and standing on the ground, he took hold of the piece of wool and was thrown several feet away by the energy flowing through the wool. This frightened him so much that he took the pieces apart and never investigated that type of arrangement ever again. He believes that it was because he was grounded when he grasped the wool, that there was such an energy flow through him. If you decide to try this with a smaller pyramid, then I suggest that you connect the wool to the lower coil first, making the earth connection that way, before tying it to the upper coil. However, let me stress again that we just don't know what is happening in and around the pyramid, so any experiments which you choose to carry out are entirely your responsibility and at your own risk. Although a good deal of practical information is given here, it must not be construed as being a recommendation that you make or use any of the devices described in this document as the presentation is for information purposes only.

Les Brown mentions other uses for the devices which he has developed. He says: *My wife, who suffered from migraine headaches, had a severe attack for a week; and during that time she took an abundant supply of pills, which proved to be of no benefit. She placed a pyramid on her head in the early hours of the night, and in about 20 minutes had been relieved of all pain. She said nothing of this to me, but two weeks later suffered another headache. Instead of suffering for a lengthy period, she used the pyramid again, and without the use of pills the headache vanished again in about the same length of time. She told me about this second episode. About a week later she suffered an ordinary headache and repeated the performance, with the same result. She now has gone three years with no headaches at all. Around this time, I had been working all day in the hot sun, and the back of my neck became quite painful. I tried placing a small pyramid on the back of my neck while I sat still for a while. It produced the same relieving results for me. I believe it increases blood circulation to the affected part.*

After about ten minutes I could feel the pain being drawn out upwards. At the same time my head felt cold on top, not cold to the touch, but simply felt cold to me. I mentioned this to my wife, and she said she had had the same sensations of coldness but was waiting for me to remark about them first. I am not suggesting that this treatment will do the same for everyone, but merely mentioning that it worked for us.

The elderly mother of a friend of mine, her hands badly crippled with arthritis, was persuaded to place her hand on an energiser. A wire pyramid was put over both hand and energiser for one hour. She continued this treatment for a few days, experiencing a diminution of pain and a loosening of her fingers each time.

Before she returned to her home in England she actually sat and played the organ. She played haltingly and rustily, it is true, but she had been unable to play at all for several years prior to using the pyramid. Significantly, her hands returned to their crippled state shortly after she returned to England as her pyramid was stolen at London Airport.

We also find that when we are feeling low and depressed, my wife and I sit for an hour or so, each with a small pyramid on our head, facing North, our depression lifts and we feel quite rejuvenated. My wife and I regularly drink pyramid-treated water. If we are feeling low we have a snifter of pyramid water and in a short time we feel a marked lift. On the other hand, if we find ourselves in what used to be described as a choleric state and sit with the pyramid on our head - but facing south -our irritability rapidly leaves and is replaced by a state of calm.

A prominent acquaintance of mine who does not wish to be named, always drives with a pyramid under his car seat. He claims he feels less "bushed" after a long drive than he did before using a pyramid. Many investigators have found that by putting a pyramid or an energiser over, or under, their beds, they experience better and more refreshing sleep, some of them claiming they need far less sleep than they required before using a pyramid for this purpose.

The real keynote when trying these pyramid experiments is persistence. As with many other experiences, pyramids do not always "work" the first time you apply one to a situation, and a person must "stay with it" and make subtle corrections until the desired results are obtained. Putting energized water into a vase containing tulips caused them to last for about three and a half weeks. Not only did they last this phenomenal length of time, but they grew about nine inches during that period ! I have never before seen flowers grow after having been cut.

Many people claim that insect stings stop itching after the application of energised water; this has been our own experience. On one occasion I had a nasty cut on my hand. Immediately after washing it with pyramid water, the pain stopped and when it was fully healed, I had no scar. The cut also healed much more quickly than is "normal" for me.

Please be aware that the energy channelled by pyramids and the Joe Cell described below is very powerful and more than capable of running a vehicle without the use of any kind of visible fuel. Dealing with this power is not an established science and we are just blundering around the edges of a science which has not been properly investigated, so at this time it is a case of discovering what tests have been carried out and analysing the results to see if there is a solid pattern leading to repeatable tests which can be performed by anyone.

We are at about the same place as the Wright brothers were in 1903 just after their successful powered flight at Kitty Hawk. They took their "Flyer" back to Dayton, Ohio and discovered that it wouldn't fly. The problem was not immediately obvious to them. Being down at sea level and in an uncomfortably high wind, was essential for their device to be able to get off the ground, but understanding why and how to overcome the problem was not immediate as the theory of practical heavier-than-air flight was not established at that time. The same situation applies today to pyramid power.

Joseph Cater's Pyramid Analysis.

There has been a good deal of disagreement between people in different locations, on how effective or otherwise, a pyramid is in day to day use. A very astute scientist by the name of Joseph H. Cater explains that this is due to the pyramid being powered primarily by energy flowing from the Sun, and so, people who live near the Equator will find a pyramid much more effective than people living in high latitudes.

Mr Cater explains exactly how a pyramid operates, but to understand his explanation fully, you will probably need to read the extract from one of his books, which is included in Chapter 15., to discover what "soft particles" are, where they come from and what effect they have on everything around us.

Mr Cater says that the energies concentrated inside a pyramid have been shown to be extremely beneficial to humans. Soft particle bombardments from outer space and especially from the Sun, concentrate inside the pyramid. Some, passing through the surface of the pyramid are slowed down to such an extent that the Earth's gravitational field, repelling the negative charges, tends to keep them inside until collisions with other particles drives them out.

Most of the particles collected by the pyramid, concentrate along the edges as would be expected, since electricity on any charged body tends to do much the same thing, with concentrations at points and along

edges. In fact, pyramid frames have been found to be nearly as effective as the closed pyramid, if, and only if, there is a continuity in the framework and no breaks in any of the joining parts.

The soft electrons collected on a pyramid frame or closed pyramid, soon reach saturation point and continued bombardment causes the excess to drop down inside the pyramid. This, coupled with the gravity-repelling forces, causes a high concentration inside the pyramid. The proportions of the pyramid are apparently a factor in its performance. If the sides are too steep, many of the soft electrons will move along the edges into the ground outside instead of being forced inside the pyramid. If the sides are not steep enough, not many particles will be collected as they strike the material at nearly a right angle which causes only a small reduction in velocity. If they strike at a sharper angle, there is a greater tendency for them to be retained by the material.

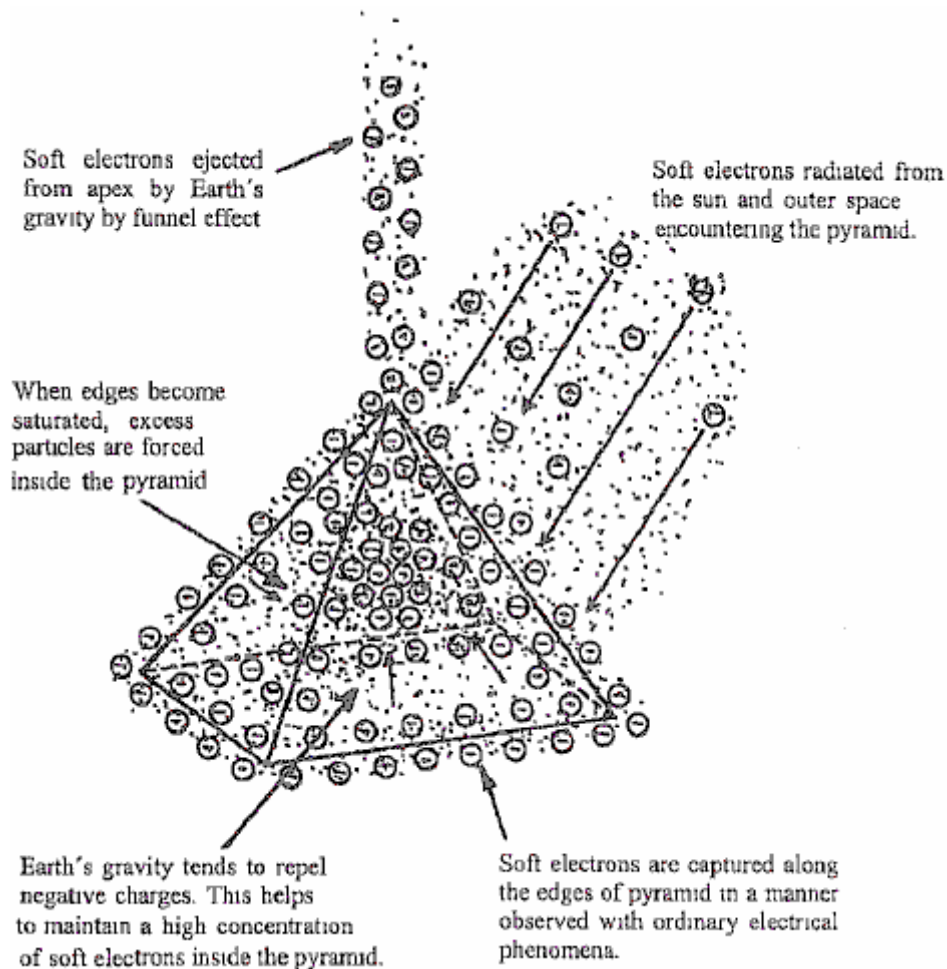

If two side of the base are aligned with magnetic North, it is allegedly more effective. Pyramids can be rendered more potent by lining the interiors of a non-metallic enclosed pyramid, with metal foil such as aluminium or copper. The foil allows a greater quantity of soft electrons to accumulate around the non-metallic outer portion because the soft particles do not pass through the metallic substance as easily, causing a back-up of soft particles. During the process, the foil absorbs large quantities of soft particles before many of them can enter the pyramid. pyramids also radiate soft electrons upwards from the peak.

Many of the soft particles which are stopped briefly on the outside of the pyramid, are repelled upwards by the Earth's gravitational field, and as well, by soft electrons attached to the pyramid. This produces a funnelling effect which ejects soft electrons from the apex of the pyramid. The Earth's gravity accelerates soft particles at a far greater rate than it does ordinary matter as soft particles are associated with ethers which are much closer to those of the gravity-inducing particles than is the case for ordinary matter. After the pyramid becomes saturated, a greater quantity of soft particles than ever, will concentrate inside. The foil will continue to radiate a high concentration of soft particles during the night when the number of particles bombarding the pyramid is considerably reduced.

It is found that pyramids work better during the summer than at any other time of the year. They are also more effective in the lower latitudes because most of the energy concentrated by the pyramid comes from the Sun. There are conflicting opinions as to the effectiveness of pyramids because of this as there is little understanding of the principles involved. For example, those who experiment with pyramids in Canada may claim that they don't work while those in Southern California will contradict them. A pyramid does not increase the flow of soft particles through the area covered by the pyramid as the same concentration flows outside the area. What a pyramid does, is impede the general flow of soft particles and produce a back-up of particles inside and below the pyramid, and consequently, a higher concentration of soft electrons in these regions. The material used in a pyramid is of great importance. This was demonstrated when a wealthy man in the Midwest built a pyramid-shaped house five stories high, which was then covered with gold-plated iron. The phenomena produced were completely unprecedented. For example, ground water was forced to the surface and flooded the first floor. This was because the soft particle concentration inside and below the pyramid was so great that ground water was impregnated with such an abnormal concentration of negative charges that it was repelled upwards by the Earth's gravity.

Gold atoms have extremely high positive electrostatic field effects, more so than any other atom. This is why gold is the most malleable of all substances. This means that soft electrons will have a greater affinity for gold than for any other metal. As a result, abnormally high concentrations of soft electrons will concentrate around gold. This effect is greatly enhanced when gold is in contact with iron. These dissimilar metals produce an EMF which in turn, causes a flow of electricity or eddy currents resulting in the iron being magnetised. The magnetic field produced, captures additional soft electrons. A higher concentration of soft electrons is created by this combination than could be produced by a similar thickness of gold foil alone. It follows that by far the most effective material that could be used for pyramids is gold-plated sheet iron (galvanised iron should not be used).

With everything else being the same, the greater the size of a pyramid, the better the performance. The reason for this is that the thicker the layer of concentrated soft electrons through which the incoming soft particles must pass, the more they are slowed down when passing. This results in a greater back-up of soft electrons and an increase in the concentration inside the pyramid. Another reason is that a large pyramid has a greater ratio of volume to surface area. Soft electrons are continuously leaking away from the surface of the pyramid, the larger the pyramid, the lower the percentage of soft electrons which is lost. Consequently, very small pyramids are ineffective.

The Devices of Pier Luigi Ighina.

Pier Luigi Ighina was a remarkable Italian scientist who died in 2004 at the age of 95. He was a colleague of Guglielmo Marconi who was well-known for his work in the early days of radio. Pier, in common with many famous scientists, had an enquiring mind, major intelligence and a very high level of patience and persistence. He too, discovered the energy flows which affect life on this planet and he had his theories and descriptions for what he observed. From his very wide range of inventions and fields of interest, just two will be mentioned here in this chapter as they relate directly to the energy flows channelled by pyramids and Joe Cells, and whether we call this energy flow 'orgone', 'soft electrons', 'OD', 'ethers', 'ambient background' or whatever, the effects are the same. Pier describes (very briefly) two important devices which have a direct effect on our health and well-being, and on our local environment generally. The first of these passive devices, he has named "**ERIM**".



He describes this device as a small apparatus which concentrates and develops what he calls "the Magnetic Rhythm Solar Earth Energy, which regenerates cells and returns them to their normal functioning". While I have not seen any specific constructional details for this device we do have a general description and several photographs which show three or four different constructions. On the surface, the device appears to be very simple and straightforward and the photographs give the impression that the construction does not have to be exact in order for it to function correctly. However, it needs to be remembered that these energy flows are directly influenced by the user and just because Pier has had spectacular results with his constructions, some of the performance may well be caused by Pier himself. Having said that, there appears to be very little to be lost by attempting a replication and quite possibly, a major amount to be gained if the replication is successful. The following four photographs show three different constructions of the device which looks like this:



Or like this:



Photographs 1 and 2 show two different views of one build. The nine spiral coils have seven turns and the narrow end is a flat turn. The gap between the yellow and blue spirals is quite large, appearing to be just under the depth of two turns of the spirals. The base is the same shape and the mounting bolt is not painted, the colour suggesting that it might be a brass bolt. The size of the mounting ring can be estimated from the man in photograph 2 and I would put it at 250 mm (10") as Pier was Italian and so probably used metric units of measurement. I doubt that the dimensions are critical and the spirals appear to be about 100 mm (4") tall with the widest turn being about 45 mm (1.75"). We are not told what metal was used for any of the construction, but as the second of Pier's devices to be described here specifies aluminium, it can't be ruled out here, although the metal does look like painted steel.

Both aluminium and copper are generally considered to be non-magnetic because a magnet does not normally attach itself to either of those metals. But, this is highly misleading as both have a major effect when placed in a magnetic field, and the energy flow being channelled by this device of Pier's is itself affected by magnetic fields, so the use of aluminium is likely to be highly significant. However, that being said, we have no direct information on what is used in this "ERIM" device.

You will notice in photographs 1 and 2, that the lugs on the arms of the bars across the circular mounting are quite short, causing their bolts to be widely spaced, which in turn, causes the outer blue and yellow spirals to be widely separated. Those lugs are longer in the build shown in photograph 3, moving the bolts closer together and bringing the blue and yellow spirals closer together. In photograph 3 the long mounting bolt at the bottom of the ring appears to be thicker and it is painted blue. The spirals have the smallest turn flat across the length of the spiral.

Photograph 4 shows a third build of the device, with an even thicker supporting bolt painted blue, wider spacing between the blue and yellow spirals and this time, the smallest turn of the spiral turned up axially and filed to a point. It appears that the device is assembled and then painted afterwards although the spirals may be dipped beforehand. Photograph 4 shows how the spirals are secured under the head of a bolt which is screwed into a threaded hole in the circular frame. Photograph 3 seems to suggest that constructional accuracy is not critical with the side spirals not aligned correctly (unless the lower spirals are supposed to point slightly inwards which seems unlikely, especially since the top spiral of photograph 3 is not truly vertical and does not align with the other two yellow spirals).

Photograph 4 seems to suggest that the green spirals can be slightly more compact than the others although they have exactly the same number of turns. Every spiral is wound the same way so when viewed from above, the upper spirals move in a counter-clockwise direction as they rise and the lower spirals move in a clockwise direction as they get lower. It might be that the colouring of the components might just be for referencing them, but I do not think that this is so. In the following device, Pier stresses the different colours and considering that different colours radiate different frequencies of light, there may well be significance in the colours. Piers describes the operation in this way:

The properties of the device are determined by it's shape. The three yellow spirals pointing upwards concentrate Solar Energy while the three blue spirals pointing downwards, concentrate Earth's bio energy which is the negative reflection from the Earth of the Solar Energy. When these two meet, they produce a wave on the green spirals called the Sun-Earth Magnetic Rhythm (which is the rhythm of everything which exists on Earth - both animate and inanimate). This wave enhances that essential basic rhythm for everything within it's operating radius, normalising and balancing cells and cleansing the energy of a room.

Ideally, the device should be placed in the bedroom so that it can act during the night, but it can also be effective almost anywhere. It should be positioned about 10-20 cm away from walls. At the beginning, to accelerate the process of cellular balancing, you can place your hands about 10-15 cm from each side of the device, with your palms turned towards the green spirals and at the same level as they are. The time required will depend upon individual sensitivity

If you have hot water central heating, you can place the device about 10 cm from the boiler with the green spirals parallel to it; the circulating water will carry information throughout the system and cleanse rooms within a few days. To energise water and return it to it's original, natural state, place a bottle of water at each side of the device, about 10-15 cm from the green spirals. It can also energise foodstuffs such as fruits, vegetables and meats by placing them level with, and about 10-15 cm in front of the green spirals, using a non-metallic support, if necessary. Flowers placed close by, will keep fresher longer, or will blossom sooner than normal.

The second passive device designed by Pier is what he calls his “**Elios**” device. It is constructed from a long small-diameter coil of aluminium wire which is snaked backwards and forwards through a circular wooden frame supported on three short wooden legs. The wooden frame is painted as shown here:



The aluminium wire coil is fed through the frame using plastic tubular beads. It is not clear if the beads pass the whole way through the frame with the upper bead meeting the lower bead in the centre of the frame, or if the beads are completely external to the wood, or perhaps partially embedded in the wood.

Pier says that the Elios device concentrates the maximum energy output in the cavity. The device is able to destroy every type of toxic pollution, including nuclear radiation. Food exposed to it's action changes completely because every chemical added to the food gets dissolved by balancing it's own Rhythm (vibration) by a multi-wave signal comprising a full octave of colours. Every type of matter receives a certain type of enhancement from it. For example, our body and all types of biological entities are healed, and growth is boosted by it.

This signal is a stationary type phenomenon of rotating particles which come from the Sun and other stars. These particles strike the Earth, store energy, and return to their sources in a reflected state which is the opposite phenomenon of discharge. Everything which was born or which is growing, changes when inside this column of light-like particles. This phenomenon is called “Solar-Terrestrial Rhythm” and it is the power supply of the Planet, continuously causing balancing and growth. Everything on the planet is continuously bathed in this stream of rotating particles.

Every type of matter has its own basic Rhythm plus the Solar-Terrestrial Rhythm. This rhythm is unique and it represents the state of tension of the specific matter. The matter grows and evolves because of this incoming energy. If you modify the energy with various types of pollution, radiation, or other types of destructive phenomena, you destroy the normal work of Nature. This device concentrates this phenomenon in it's immediate local area and as a result, it improves the Health and Life Energy of that local environment.

The Elios device is only a passive resonator, tuned by its shape to resonate with a harmonic of the cosmic event signal. It consists of a ring of painted wood with seven holes positioned in a heptagon shape in its perimeter. This ring is supported on three legs evenly spaced around the circle. On every hole there is a piece of a coloured plastic tube, each one having a different colour and positioned in a particular order.

The sinusoidal conductor is made of aluminium wire, wound clockwise, and inserted through every hole in a serpentine movement, leaving one end facing upwards and the other end facing downwards, parallel to each other. The signal coming from the sky, moves in a clockwise direction. The two ends of the aluminium wire coil finish in adjacent holes. One end points towards the sky and the other end points towards the ground.



The device should be located on open ground and not on concrete which generates an out-of-phase component of the earth signal which destroys the good rhythm. The phenomenon occurs in the cavity especially, and around the perimeter of the ring. To increase the amplitude of the signal you can put **glass** bottles filled with water, one inside the cavity and six around the outside in a hexagon shape. Wait some days and observe the environment. Everything changes! There is an explosion of life! Everything which I have described happens, depending only on the length of elapsed time and the amplitude of the signal. The device needs sunlight for its best operation. Take it away from every artificial electrical and magnetic field because this is only a passive resonator and a strong EMF can distort its' signal.

Do not try nuclear cleansing with Elios until it is highly charged. The device is a passive resonator and it needs to build up a charge before bringing any isotopes near it. When dealing with isotopes, always use water containers but do **not** contact the substance with the apparatus as you can destroy the ambient rhythm by doing that, and cause very big trouble in the area. This device has a powerful resonant effect on the surrounding land, influencing the environment up to a kilometre in every direction.

The Joe Cell.

The device called the "Joe Cell" used to be one of the most difficult devices for any experimenter to get operating properly but new design data has changed all that. It is a passive device for concentrating energy drawn from the local environment and it takes great perseverance and patience to use one to power a vehicle. Here is some practical information on the Joe Cell.

In 1992 in Australia, Graham Coe, Peter Stevens and Joe Nobel developed previously patented units which are now known by the generic name of the "Joe Cell". Peter introduced Joe to Graham and they rehashed the patented cells which Graham knew about, using materials from the Local Dairy Production Facility NORCO. A two hour long video showing the Joe Cell was produced by Peter and Joe and the unit shown operating in the video was attached to Peter's Mitsubishi Van. Joe had his equipment stolen and his dog killed, so he decided to keep a low profile, moving out into the wilds and not generating much publicity, in spite of fronting the two hour video recording. A search on the Joe Cell will locate many videos on the subject. This document is an attempt to provide detailed information on a recent Cell built by Bill Williams in the USA and the subsequent constructional advice which has arisen from his experiences.

First, you need to understand that, at this point in time, building and using a Joe Cell of any variety, is as much an art as a science. It might best be explained by saying that creating building plans for it is rather like producing plans for painting a copy of the famous Mona Lisa painting. The instructions for the painting might be:

1. Buy a canvas, if one is not available, then here is how to make one.
2. Buy some oil-based paints, if none are available, then here is how you make them
3. Buy an artists brush, palette and charcoal, if none are available then this is how you make them.
4. Here is how you paint the picture.

Even given the most complete and detailed instructions, many people, including myself, are unlikely to produce a top-quality copy of the Mona Lisa. It is not that the instructions are lacking in any way, it is the skill and ability of the person attempting the task which are not up to the job. It used to be that not everybody who built a Joe Cell had instant success. However, recent advances have changed all that, but let us run through the earlier constructional information as a lead-in to the current technology.

A Joe Cell is capable of powering a vehicle engine without needing to use conventional fossil fuel. So, what does the engine run on? I suggest that it runs on a newly discovered energy field not yet understood by mainstream science. In another couple of hundred years time, it will be a routine subject which every child in school will be expected to understand, but today it looks like the 'witchcraft' of the magnifying glass starting a fire.

It is not unusual for newcomers to the subject to get confused by the Cell itself. The Cell consists of a metal container with tubes inside it. The container has what looks like ordinary water in it and it sometimes has a DC voltage applied across it. This causes many people to immediately jump to the false conclusion that it is an electrolyser. It isn't. The Joe Cell does **not** convert water to hydrogen and oxygen gasses to be burnt in the engine. The water in a Joe Cell does not get used up no matter how far the vehicle travels. It **is** possible to run a car on the gasses produced by electrolysis of water, but the Joe Cell has absolutely nothing whatsoever to do with electrolysis. The Joe Cell acts as a concentrator for a new energy field, in the same way that a magnifying glass acts as a concentrator for sunlight, and both have to be done just right for them to work.

At the present time, there are at least fifteen people who have built Joe Cells and managed to power vehicles using them. Several of these people use their Joe Cell-powered vehicles on a daily basis. Most of these are in Australia. The first Cell-powered vehicle was driven some 2,000 kilometres across Australia.

Disclaimer: The remainder of this document contains considerable specific detail on the design and construction of a Joe Cell. This presentation is for information purposes only and must not be construed as a recommendation that you actual physically construct a device of this nature. The author stresses that he is in no way liable for any damage, loss or injury caused by your future actions. It should also be borne in mind that any alteration to an automotive vehicle, such as changing the fuel on which it runs to hydroxy gas, natural gas, Joe Cell energy, or anything else, might void the vehicle insurance unless the insurer is informed beforehand and agrees to continue insurance cover on the modified vehicle.

In broad outline, a Joe Cell is a 316L-grade stainless steel container, with a central cylindrical electrode, surrounded by a series of progressively larger stainless steel cylinders, and filled with specially treated water. This arrangement of steel shells and treated water acts as a focusing mechanism for the energy field used to power the vehicle.

The Cell itself is made up with the battery negative taken to the central electrode. The connection to this stainless steel electrode is made at the bottom with the electrical connection passing through the base of the cell container. This obviously needs careful construction to prevent any leakage of the conditioned water or the energy focused by the Cell.

Surrounding the central electrode are two or three cylinders made of either solid or mesh stainless steel. These cylinders are not connected electrically and are held in position by insulating material which needs to be selected carefully as the insulation is not just electrical insulation but is also energy-field insulation. The outside stainless steel cylinder forms the container for the cell:

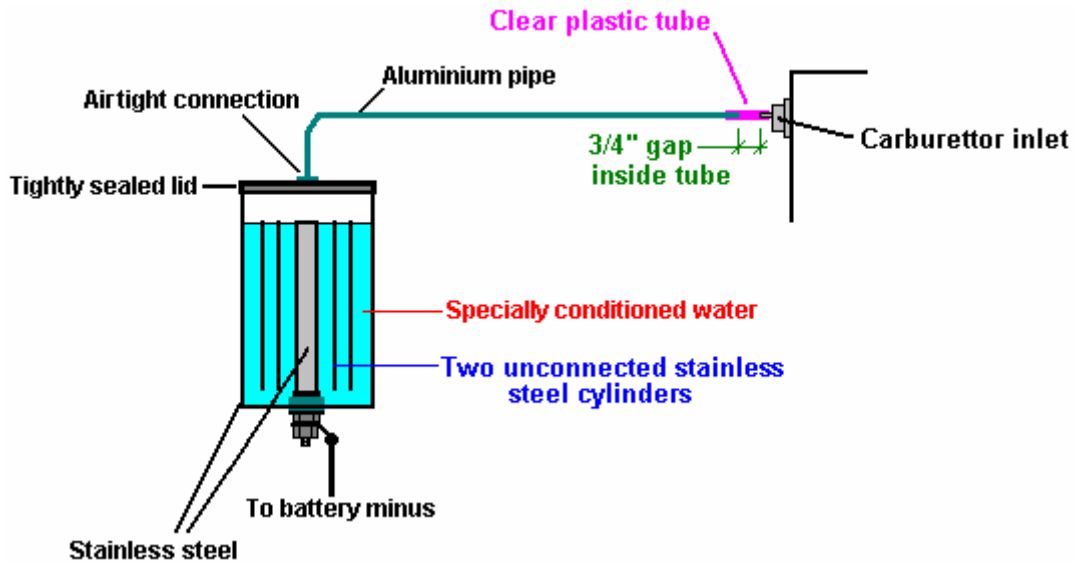

The picture above shows the general construction of a cell of this type although, unlike the description below, this one does not have the lip which is used for attaching the lid. It is included here just as a general illustration of how the cylinders are positioned relative to each other.

The following information on constructing a Joe Cell, is broken down into the following sections:

1. The Materials needed for construction.
2. Constructing the Cell
3. Getting the Cell working
4. Installing the Cell in the vehicle
5. Getting the vehicle running
6. Suppliers
7. Workarounds

The Materials needed for Construction.

Various vehicles can be powered by a Joe Cell. If you have not built and used a Joe Cell before, then it is worth using the easiest type to convert. The most suitable is an older type vehicle with no computer control of the combustion, a carburettor and a water-cooled engine. If the engine block is aluminium rather than steel then that is also a slight additional advantage.

The Cell is built from stainless steel pipes. The lower the magnetism of the finished unit the better, so 316L grade stainless steel is preferred. However, there is no need to become obsessed with this as most varieties of stainless steel can be persuaded to operate. The length of the tubing is not critical, but about 8 inches (200 mm) is a reasonable choice for the overall length of the inner tubes. The outer pipe which forms the casing, needs to be about 10 inches in length so that there is clearance above and below the inner pipes.

The innermost pipe diameter is 2 inches (50 mm) and the others can be 3 inch, 4 inch, and 5 inches in diameter as that creates a gap of just under half an inch between the pipes, which is a suitable spacing. The wall thickness of the pipes is not critical but it needs to be a practical size with 1 mm being the minimum thickness with the most common thickness being 1/16 inch (1.6 mm or 0.0625 inch). It is important that the walls of the outermost cylinder are completely rigid, so using a greater thickness for that cylinder is an advantage.

Some stainless steel plate is needed for the ends of the outer cylinder. Ideally, the top and base should not overhang the sides but that is difficult to achieve if the cell is to be airtight, so the end pieces will need to be slightly larger than the outside tube and 1/8 inch (3 mm) thick sheet is suggested. The base size is 5 inch square, or possibly slightly larger to facilitate cutting a circular shape out of it. The lid and lip blanks will need to be 6 inch squares, or again, slightly larger to facilitate cutting circles out of them.

The plinth component at the base of the 2-inch inside tube needs to be cut from a piece of stainless steel. If the option of machining the whole plinth as a single piece is chosen, then the piece of 316L stainless steel needed to do this will be substantial, perhaps a section of solid bar 2.25 inches (57 mm) in diameter and some 3 inches (75 mm) long. If the easier and cheaper option of using a standard half-inch (12 mm) 316L stainless steel bolt (if one is available) is selected, then a piece of 316L stainless steel some 2.25 inches (57 mm), or slightly larger, 2 inch (50 mm) thick will be needed. The exact details of this will need to be discussed with the person who will undertake the machining as practical issues come into play, and the optimum size will depend to a certain extent on the lathe being used. If a screw thread is being machined on the spigot of the plinth, then the thread should match the locally available nuts, unless nuts are also being made up.

Some additional steel will be needed for constructing a mounting bracket inside the engine compartment, also, some double-laminated hessian sacking ("burlap") and about 36 inches (1 m) of half-inch (12 mm) wooden dowel to use in the mounting bracket.

Some Ultra-High Molecular Weight Polyethylene material as found in kitchen chopping boards will be needed to insulate between the engine mounting and the cell and between the inside tube's plinth and the base plate.

A length of aluminium tubing typically three quarters of an inch (20 mm) in diameter will be needed for connecting the Cell to the engine, and a short length of strong, clear plastic pipe for the actual final connection to the engine, needed to prevent an electrical short-circuit between the Cell and the engine. This plastic pipe needs to be a tight push-fit as clamping clips are not used. A stainless steel compression fitting to fit the pipe is needed to make the seal between it and the lid of the Cell. It is very important that this fitting is stainless steel as other materials such as brass will prevent the cell from operating. The wrong material for this fitting has been the reason for many Cells not operating. Neither brass nor any other material (other than stainless steel) should not be used anywhere in the construction, whether it be for nuts, bolts, fittings, metal connections, or anything else.

Ideally, natural rubber with no additives or colouring, failing that "Buna-n" (nitrile rubber) o-ring, or teflon, is needed for inter-cylinder bracing and some sheet to make the circular lid gasket. Also some white marine-grade Sikaflex 291 bedding compound. Natural rubber with no colouring or additives is the best insulator and should be used if at all possible. After extended use, Bill has found that teflon spacers work better than the rubber and so has switched to teflon.

Seven or eight stainless steel cones will be needed for the water-conditioning process. These are usually manufactured for machines which separate cream from milk and it is possible to buy them via eBay from time to time. If none are available, then it is perfectly possible to construct them yourself.

There will also be minor items like a few bolts, lengths of electrical wire and the like. To summarise this then:

Stainless steel pipes in 316L grade steel:

- 5-inch (125 mm) diameter 10 inches (250 mm) long, one off
- 4-inch (100 mm) diameter 8 inches (200 mm) long, one off
- 3-inch (75 mm) diameter 8 inches (200 mm) long, one off
- 2-inch (50 mm) diameter 8 inches (200 mm) long, one off

Stainless steel plate in 316L grade steel:

- 5.25 inch (133 mm) square 1/8 inch (3 mm) thick, one off
- 6.25 inch (157 mm) square 1/8 inch (3 mm) thick, two off
- 3 inch (75 mm) strip, 16 gauge thick, two feet (600 mm) long
- One plinth blank as described above, size depending on the lathe and style of construction.

Stainless steel bolts:

- 1/4 inch (6 mm) diameter, 3/4 inch (18 mm) long, twelve off with matching nuts
- One 1/2 inch (12 mm) diameter, 2.25 inch (57 mm) long with two nuts and three washers

Aluminium tubing 3/4 inch (20 mm) in diameter, 3 feet (1 m) long

Plastic tubing to form a tight fit on the aluminium tubing and some 4 inches (100 mm) long

One stainless steel compression fitting to seal the pipe-to-lid connection

Natural rubber with no additives, (or "Buna-n" insulation if natural rubber just cannot be got):

- O-ring tubing, 3 feet (1 m) long
- Sheet, 6 inch (150 mm) square, one off

Miscellaneous:

- White Sikaflex 291 bedding compound (available from ships chandlers), one off
- Double-laminated hessian sacking ("burlap") 1 foot (300 mm) wide, 6 feet (2 m) long
- Wood (ramin) dowel three quarter inch (18 mm) diameter, 36 inches (1 m) long
- UHMWP plastic food-chopping board, one off
- Sundry connecting wire and ordinary engine compartment mounting bolts, and the like
- Stainless steel cones and canister as discussed below

Don't polish the tubes and never, ever use sandpaper or wet-and-dry paper on any of these components as the result is scored surfaces and each score reduces the effectiveness of the Cell.

Constructing the Cell

The Joe Cell looks like a very simple steel construction which could easily be made by any amateur. While it can be constructed by an amateur, it is not a simple construction as it is important to keep any acquired magnetic properties to a minimum. Consequently, it is suggested that an angle grinder is not used for any of the metalwork, and hand tools used for cutting and shaping. Also, if the cutting tool has previously been used to cut anything other than stainless steel it should not be used, or at the very least, thoroughly cleaned before use as contamination of your Cell components through particles of another material is critical and can prevent the Cell from working. It should be stressed again that the materials used in the construction of a Cell are absolutely critical if success is to be assured. If you have an experienced friend who has made many Cells work, then you can experiment with different materials, but if this is your first Cell and you are working on your own, then use the exact materials shown here and don't end up with a Cell which doesn't work.

Bill Williams started building a 5 cylinder cell comprising 1", 2", 3", 4" and outer tube 5" but Peter Stevens later advised him to remove the 1" centre tube and go with only two neutrals being the 3" and 4" tubes as the 1-inch diameter is too small for optimum energy pick-up.

Please accept my apologies if the following suggestions for construction seem too basic and simple. The reason for this is that this document will be read by people whose first language is not English and who will find it much easier if plenty of detail is provided.

The first step is to construct the base plate, used to form the bottom of the container. Cut the largest diameter pipe to a 10-inch (250 mm) length. (If you have difficulty in marking the cutting line, try wrapping a piece of paper around it, keeping the paper flat against the tube and making sure that the straight edge of the paper aligns exactly along the overlap, then mark along the edge of the paper). Place the pipe on one of the end blanks and mark the blank around the bottom of the pipe. Cut the blank to form a circular plate which sits flush with the bottom of the tube:

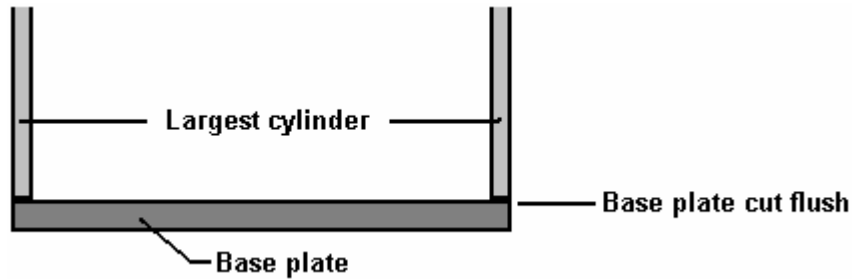

The next step is to mount the innermost 2-inch (50 mm) diameter pipe rigidly to the base plate. Cut the pipe to an 8-inch (200 mm) length. The pipe mounting needs to be exactly in the centre of the plate and exactly at right angles to it. This is probably where the most accurate work needs to be done. To complicate matters, the mounting needs to be connected electrically outside the base, be fully insulated from the base plate, and make a completely watertight fit with the base plate. For that reason, the arrangement looks a little complicated. Start by drilling a three quarter inch (18 mm) hole in the centre of the base plate. Construct and fit two insulating washers so that a half-inch stainless steel bolt will fit through the base plate while being securely insulated from it. The washers are made from Ultra-High Molecular Weight Polyethylene (plastic food-chopping boards are usually made from this material):

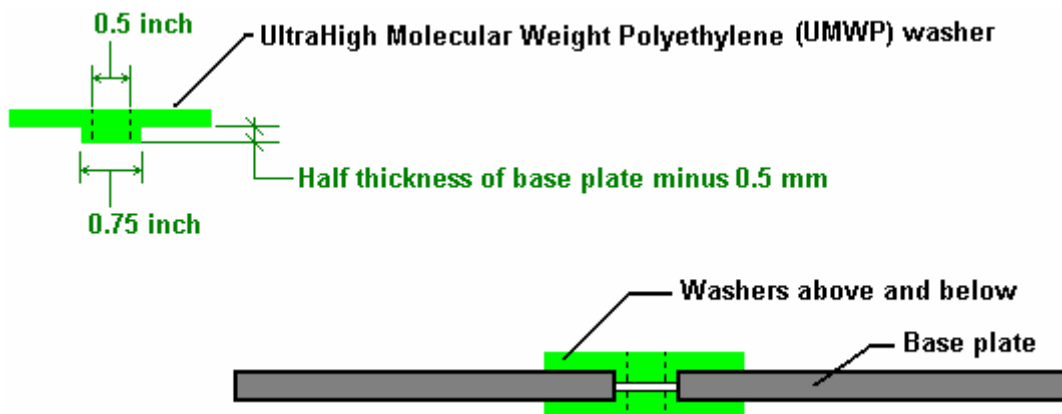

The washers which fit into the hole in the base plate need to be slightly less than half the thickness of the plate so that they do not actually touch when clamped tightly against the base plate, as shown in the lower part of the diagram. Cut another washer, using the full thickness of the plastic sheet. This will act as a spacer.

Next, the plinth for the central 2-inch diameter cylinder needs to be made. This is the only complicated component in the construction. It is possible to make this component yourself. The local university or

technical college will often be willing to allow you to use their lathe and their staff will usually do the job for you or help you to do it yourself. Failing that, your local metal fabrication shop will certainly be able to do it for you. If all else fails and this equipment is just not available, then the 'workarounds' section below shows how to fabricate an alternative version which does not need a lathe.

A large piece of 316L stainless steel needs to be machined to produce the plinth shown below. The actual 2-inch diameter central cylinder needs to be a tight push-fit on the top of this component. To facilitate assembly, the central boss is given a slight chamfer which helps alignment when the tube is forced down on top of it. Peter Stevens recommends that tack welds (in stainless steel using a TIG welder) are used to connect the plinth to the outside of the cylinder. Three evenly-spaced vent holes are drilled in the plinth to allow the liquid inside the Cell circulate freely inside the central cylinder.

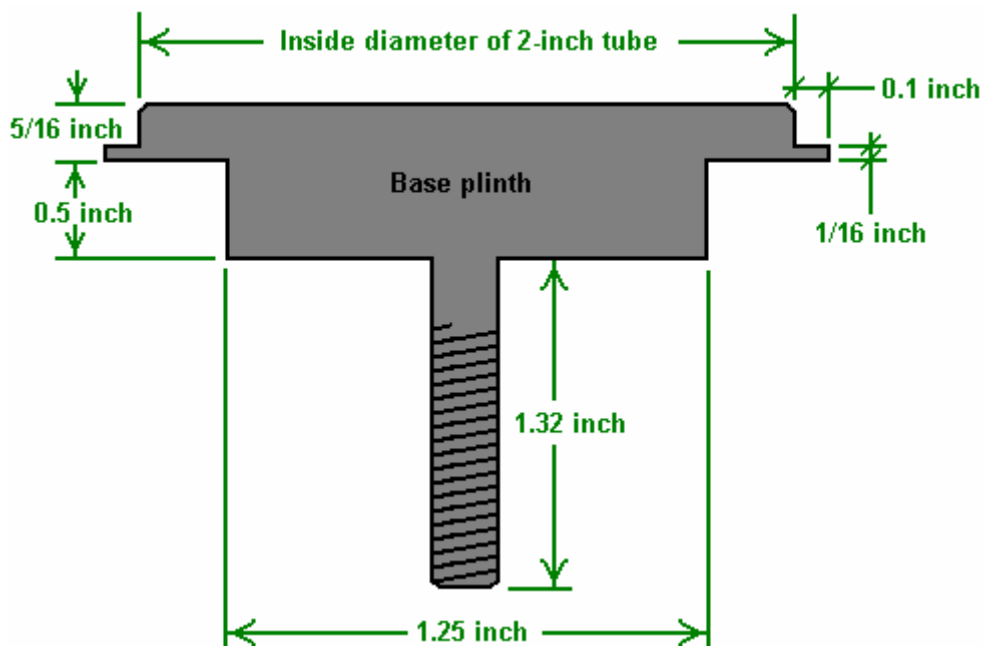

An alternative method of construction which does not call for such a large amount of machining is to machine the plinth to take a standard stainless steel bolt as shown here:

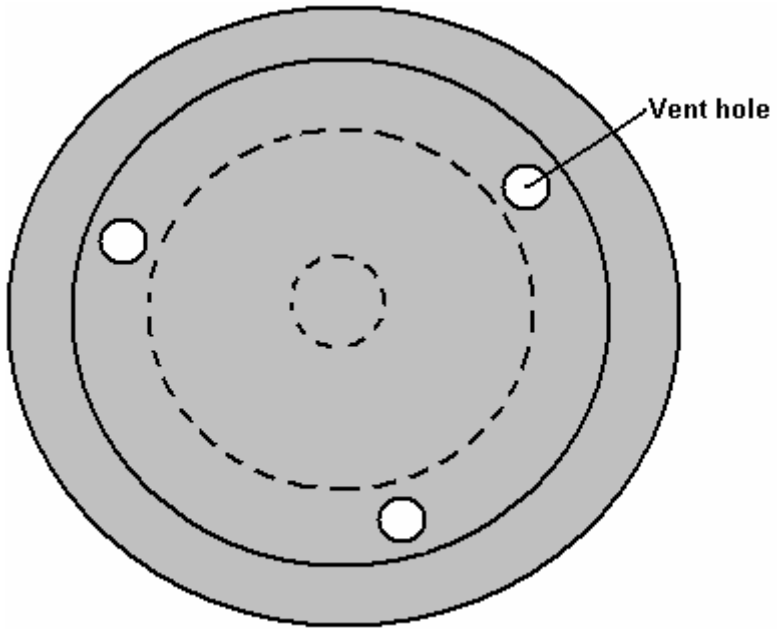
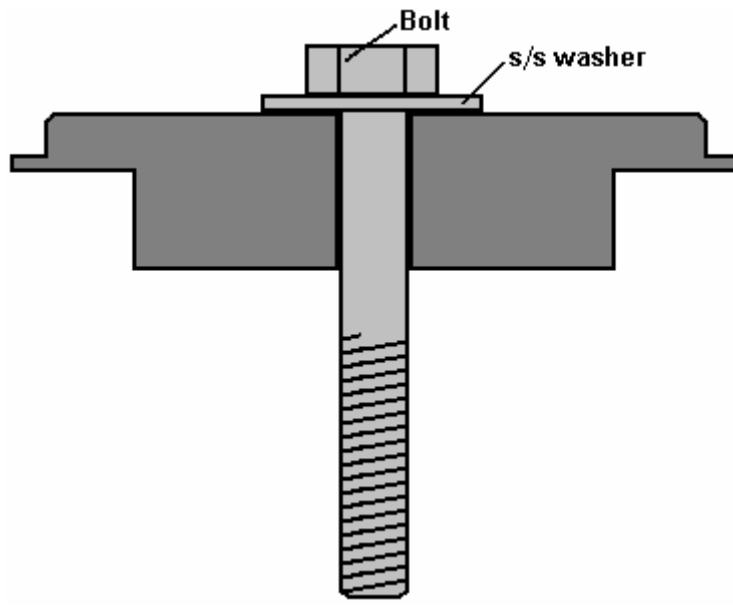

PLAN VIEW

When assembled, the arrangement should look like this:

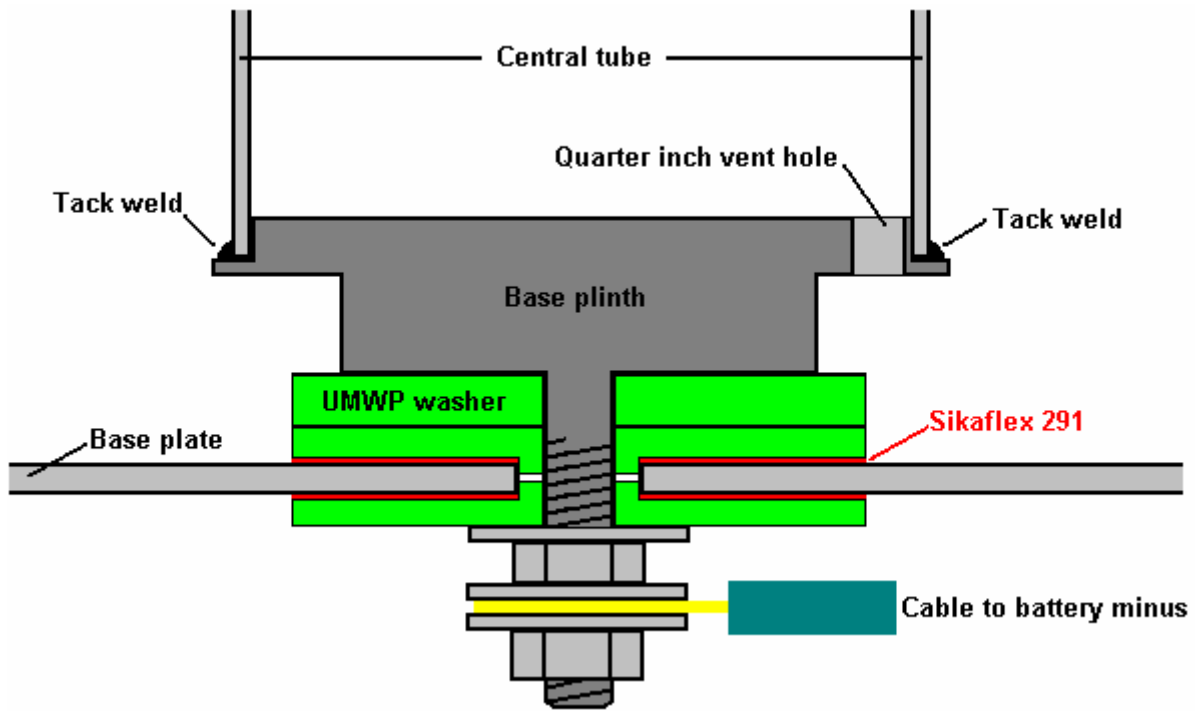

This arrangement looks more complicated than it really is. It is necessary to have a construction like this as we want to mount the innermost tube securely in a central vertical position, with the battery negative connected to the cylinder, by a connection which is fully insulated from the base plate and which forms a fully watertight seal with the base plate, and to raise the central cylinder about one inch (25 mm) above the base plate.

However, as the plastic washers would be affected by the heat when the base plate is joined to the outermost pipe, when all of the components shown have been prepared, they are taken apart so that the base plate can be fuse-welded to the outside tube. Unless you have the equipment for this, get your local steel fabrication workshop to do it for you. Be sure that you explain that it is not to be TIG welded, but fuse-welded and that the joint has to be fully watertight. At the same time, get them to fuse-weld a half-inch wide lip flush with the top edge of the tube. You cut this piece as a 6-inch (150 mm) circle with a 5-inch (125 mm) circular cut-out in the centre of it. When it is welded, it should look like this:

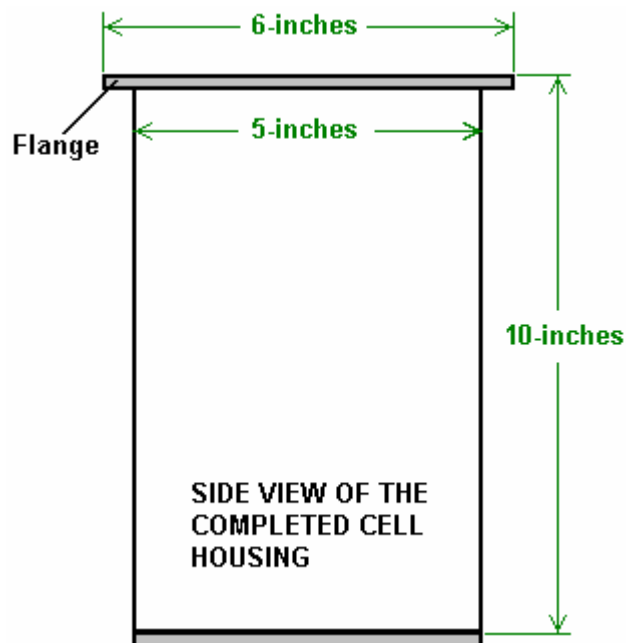

Cut a six-inch (150 mm) diameter lid out of 1/8 inch (3 mm) stainless steel. Cut a matching ring gasket of natural rubber (Buna-n material if natural rubber can't be obtained), place it on top of the flange with the lid on top of it and clamp the lid firmly down on the flange. Drill a hole to take a 1/4 inch (6 mm) stainless steel bolt, through the lid and the middle of the flange. Insert a bolt and tighten its nut to further clamp the lid in place. An alternative to this for the more experienced metalworker, is to drill a hole slightly smaller than the bolt, and when all holes have been drilled, remove the lid, enlarge the lid holes to allow free passage of the bolts, and cut a thread inside the flange holes which matches the thread on the bolts to be used. This gives a very neat, nut-free result, but it calls for a greater skill level and more tools.

If using nuts and bolts, drill a similar hole 180 degrees away and fasten a bolt through it. Repeat the process for the 90 degree and 270 degree points. This gives a lid which is held in place at its quarter points. You can now complete the job with either four more evenly-spaced bolts or eight more evenly-spaced bolts. The complete bolting for the twelve-bolt choice will look something like this when the cell is installed:



The lid can be finished off by drilling its centre to take the fitting for the aluminium pipe which will feed the output from the cell to the engine. This fitting, in common with every other fitting **must** be made of stainless steel. Video at <http://youtu.be/-7075bVmDQo>.

The next step is to assemble the neutral pipes. Cut them to 8-inch (200 mm) lengths. These pipes are held in place by the natural rubber insulators. This material comes in an o-ring strip which is like a hosepipe with a large wall-thickness. The gap between the pipes will be approximately half an inch (12 mm), so cut each piece of pipe to a length which makes it a very tight fit in that gap. Cut six spacers, locate the 3-inch diameter pipe exactly over the inner pipe and push three of them between the pipes, about a quarter of an inch from each end and evenly spaced 120 degrees apart around the circumference of the pipes. The hole through the centre of the insulating strip points towards the centre of the cell and the ends of the insulator pieces press against the cylinder walls. These pieces are **not** placed lengthwise:

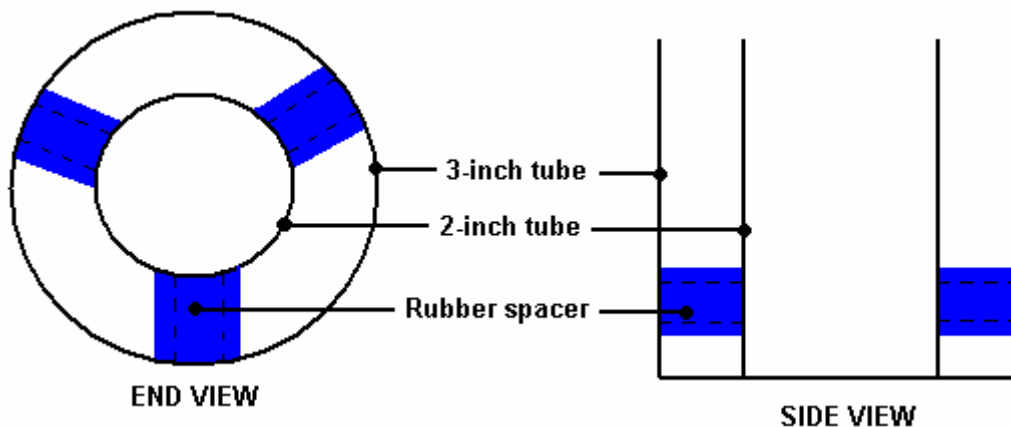

Place similar insulators at the other end of the two-inch pipe, directly above the ones already in place. If you look down the length of the tubes, then only three of the six insulators should be seen if they are correctly

aligned. The spacers will be more effective if the ends are given a thin layer of the Sikaflex 291 bedding compound before the ends get compressed against the cylinder walls.

Do the same for the four-inch pipe, pushing tightly squeezed natural rubber insulators strips between the three-inch and four-inch pipes. Place them directly outside the insulators between the two-inch and three-inch pipes so that when viewed from the end, it looks as if the rubber forms a single strip running through the middle pipe:

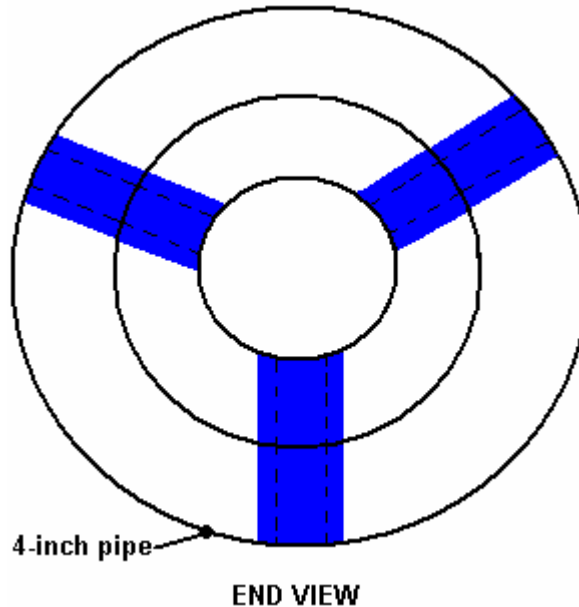

Spark off each of the cylinders in the inner assembly. This is done by connecting a 12V battery negative to the inside surface (only) at the bottom of the tube and with a wire from the battery positive, sparking the outside surface of the cylinder at the top of the tube. Give each four sparks in rapid succession.

If you are using a bolt rather than a machined spigot, insert the stainless steel bolt and washer through the bottom of the base to the central pipe. Wedge the bolt in place by inserting a piece of the dowel, or some similar material into the centre of the 2-inch pipe and tape it temporarily in place. Alternatively, force the innermost cylinder tightly over the machined plinth. Turn the inner pipe assembly upside down and place the full-depth UMWP plastic washer on the threaded shaft. Apply a thin layer of white Sikaflex 291 bonding compound to the face of one of the shaped UMWP washers and place it on the threaded shaft with the bonding compound facing upwards.

Carefully clean the surface of the base plate of the outer casing around the central hole, both inside and outside. Under no circumstances use sandpaper or wet-and-dry paper, here or anywhere else, as these abrade and score the surface of the steel and have a major negative effect on the operation of the Cell. Carefully lower the 5-inch outer casing on to the assembly so that the threaded shaft goes through the central hole and the shaped washer fits tightly into the hole in the base of the outer housing. Apply a thin layer of the bonding compound to the face of the second shaped washer, place it over the shaft of the bolt and press it firmly into place to completely seal the hole in the base plate. Add a stainless steel washer and bolt and tighten the bolt to lock the assembly together. If using a bolt, a long-reach box spanner may be needed inside the central pipe for tightening the locking bolt. If one is not available, use a longer bolt through the washers, screw a second nut up on to the shank of the bolt, file two flats on the end of the bolt, clamp them in a vice to hold the bolt securely and tighten the locking nut. When the spare nut is unscrewed, it pushes any damaged fragments of the bolt thread back into place.

Finish the assembly by adding three further rubber insulators between the top of the 4-inch tube and the outer 5-inch casing. Use a thin layer of Sikaflex 291 bonding compound on the cut faces of the insulators as this improves the insulation. Line the new insulators up with the insulators already in place and make them a tight fit. These extra insulators support the end of the tube assembly and reduce the stress on the plinth fitting at the base of the central tube when the unit is subjected to knocks and vibration when the vehicle is in motion.



The construction of the basic unit is now complete, with the exception of the lid fitting for the aluminium pipe which feeds the engine. The construction so far has been straightforward engineering with little complication, but the remaining steps in getting the Cell powering a vehicle are not conventional engineering. If you do not feel confident about this construction, then advice and help can be got from the experienced members at the Yahoo Group <http://groups.yahoo.com/group/joecellfreeenergydevice/> or alternatively, the companion Group <http://groups.yahoo.com/group/JoesCell2> both of which are very active.

Getting the Cell working

The Cell is not just the container and the inner tubes. A major active ingredient of the "Cell" is the liquid placed inside the container. To a casual glance, the liquid appears to be water and loosely speaking it is water. However, water is one of the least understood substances on the planet. It can have many different molecular configurations which give it widely different characteristics. For example, in one configuration, it will actually burn, but this "burning" is nothing like the burning experienced in an ordinary log fire. The water flame is not hot and it is quite possible to hold your hand just over the flame without feeling any heat from it.

We do not want to "burn" the liquid in the Cell. The "conditioned water", for want of a better description, is not consumed when a Cell powers an engine. Instead, the engine is powered by external energy flowing into it. Here, the Cell acts like a lens, concentrating the external energy and focusing it to flow along the aluminium pipe to the engine. This action is not unlike the way in which a magnifying glass gathers and concentrates the sun's energy into a small area to raise the temperature there. The "conditioned water" in the cell, along with the materials and shapes in the Cell, cause the gathering and concentration of this external energy and channel it into the engine.

At this point in time, nobody knows for sure, what the energy is. Earlier, I called it the Zero-Point Energy field, but I have no direct evidence for that, some people call this energy "orgone". Nobody knows exactly how this energy makes the engine run. Engines powered by this energy sound pretty much the same as when they are running on fossil fuels but they run a lot colder and it is usually necessary to advance the timing of the spark. These engines can tick over at a much lower rate than normal and they have much greater power than when running on fossil fuels. Bill Williams in America found that when he fitted a Joe Cell to his Ford pickup, the performance suddenly became like a Formula One racing car and very gentle use of the throttle was needed. He says:

"Over the summer, I used the truck to haul firewood for this winter's wood supply. I added 5 gallons of fuel to bring the fuel level to the half tank mark. I ran the truck with the cell which I installed a month earlier. Basically, I tried to forget about the cell being installed in the truck. The Ignition timing was set at about 25 degrees before TDC with no vacuum connect to the distributor. The fuel line was still connected so "shandy"

mode was being used. The surprising thing is that the truck did not use any fuel during the two and a half months of driving in the woods. In fact, when I parked the truck at the end of the wooding season, I physically sounded the fuel tank (it is a 'behind the seat' tank). It was still showing the half full mark. I pulled the cell for the winter and have it sitting on the bench waiting for spring to arrive for it to be installed again. I don't even pretend to understand this technology, but I keep hoping that someone will come up with a viable explanation of how the cell works".

Anyway, how do we get "conditioned water"? It can be generated inside the Cell, but as the conditioning process usually generates an unwanted residue on top of the water and on the bottom of the Cell, there is an advantage to do the conditioning in a separate container. If water conditioning is done in the Cell, then when the residue is removed, the Cell does not have the correct amount of water and needs to be topped up. That has to be done with non-conditioned water which promptly puts the Cell back to square one. So, use a separate conditioning vat which contains considerably more water than the Cell needs. In the documentary video produced by Peter and Joe, the conditioning procedure is described in some detail.

Joe explains that he conditions the water by suspending an electrode array in the water and applying 12 volts DC to it. Using the water found local to Joe, the current is initially about 10 amps and if left overnight the current drops to anywhere between 2 amps and 4 amps. This indicates that his local water contains a large amount of dissolved material since completely pure water will carry almost no current when 12 volts DC is placed across it. It is almost impossible to get pure water as so many things dissolve in it. Raindrops falling through the atmosphere pass through various gasses and some of these dissolve in the droplets. If the pollution in the atmosphere is particularly bad, then the rain can become acidic and this "acid rain" can rot the trees and vegetation on which it falls. Water on and in the ground, picks up chemical elements from nearly everything with which it comes in contact, so water, any water, needs treatment to reach its "conditioned" state.

Joe's conditioning electrode array is made up from truncated stainless steel cones, positioned vertically above one another. Joe describes it as being made up from seven cones (not strictly true) with the central cone connected to the battery positive and the top and bottom cones connected to the battery negative. That leaves two unconnected cones positioned between the positive and each of the two outer negative cones. His array looks like this:



What Joe does not mention, but what can be seen in the video, is that there is an eighth cone cut-down and tack-welded in an inverted position underneath the bottom cone:



The inverted cone section appears to project underneath the rim of the bottom cone by an amount of about one inch (25 mm), or perhaps slightly less:



The electrical straps connecting to the cones are insulated to prevent contact with either the other cones or the inside of the metal drum which Joe uses to hold the water being 'conditioned'. He says that if this array is suspended in a tank of water (his happens to be a vertical metal cylinder - a significant shape) and provided with 12 volt DC electrical power for a few minutes, then the water becomes 'charged' as he expresses it. Although the water is supposedly clean, Joe gets gas bubbles coming off the surface of the water. These will explode if lit, so it is very important that this process is carried out in the open air and there is no possibility of the gas ponding on a ceiling.

Joe states that the cleaner the water the better the result. Also, the longer the array is immersed and powered up, the better the result. It is likely that the shape of his powered array is causing the energy field to flow through his water in a concentrated fashion. The water absorbs this energy, and the effect increases with the length of time it is being conditioned, until a maximum level is reached. The objective is to achieve unusually pure water in one of its least usual molecular configurations. The overall procedure is as follows:

1. A vertical stainless steel cylinder, with an open top, is obtained and filled with water. Joe uses a steel beer keg but he selects the keg very carefully indeed from a very large choice of kegs, and then cuts the top off it. There is no need to have such a large container, or cones as large as the ones which Joe uses.
2. The array of cones is suspended vertically in the middle of the water and 12 volts applied to it. The Cell is most definitely **not** any form of electrolyser and should never be confused with one. An electrolyser

operates by breaking water down into hydrogen and oxygen gasses which are then used for combustion inside an engine, and it requires rapid and continuous replacement of the water which gets used up as the engine runs. The Joe Cell never operates in that way, instead it channels outside energy through to the engine and the water inside a Joe Cell is never used up by the engine running. However, in this conditioning process, some hydrogen and oxygen are produced as a side effect of the purification process. Consequently, the conditioning should be carried on out of doors to prevent any hydrogen ponding on the ceiling and forming an explosive mixture there. The more impure the water, the higher the current which flows and the greater the unwanted electrolysis of some of the water.

3. The procedure for applying the 12V supply to the conditioner electrodes is unusual. First, connect the negative supply, and **only** the negative supply. After 2 to 20 minutes, make the positive connection for just 2 or 3 minutes. A residue of impurities will form from this process. Some, being lighter than water, rise to the surface and form a layer there. Some being heavier than water, sink to the bottom. The surface residue is removed and the process repeated until a surface layer no longer forms. This may take 24 hours. The clean water from the middle section of the container is used to fill the Cell.

Many people are of the opinion that a current of about one amp should flow through the conditioning vat in the early stages of the process. If the current is much less than this, then it may take a considerable length of time to get the processing completed - possibly one or two weeks if the water needs a good deal of work done on it. The process can be speeded up by using higher voltage, 24 volts or 36 volts by adding extra batteries or using an electronics bench power supply. The water can also be pre-processed by placing it in a glass jar in an orgone accumulator for a day or two, but that process is outside the scope of this description.

As the impurities get ejected from the water by this process, the electrolysis element gets stifled progressively and as a consequence, the current drops. As completely pure, molecularly-reconfigured water is the goal, no additives of any kind are normally added to the water used to fill the Cell. However, if citric acid is used to clean the cylinders before assembly, there is no harm in allowing them to be assembled in the Cell with traces of the acid on them.

The Cell is filled to just under the level of the top of the inside tube array. This is very important as we need to have separate cylinders of water divided by the steel cylinders. If the water level is over the top of the cylinders, then the whole charging arrangement is destroyed. Further water conditioning inside the Cell may be needed as the cylinders also need to be conditioned. This is done with an easily removable cover replacing the lid of the Cell. The Cell should be kept covered while it undergoes its further conditioning and the lid only lifted briefly to examine the bubbles (unless a glass lid is used). The positive connection to the cell is made to the outside of the 5-inch cylinder and at the top of the cylinder. A length of copper wire tightened around the top of the cylinder is a convenient way to make the connection to the outside (and only the outside) of the cell. Place the cell on a wooden workbench or failing that, on a sheet of high-density plastic such as a chopping board. Connect the negative wire and wait two minutes before connecting the positive wire.

The Cell is ready for use, when it continues to produce surface bubbles for hours after the 12 volt DC power supply is removed from the Cell. The bubbles produced are not part of the energy-focusing process and are themselves unimportant, but they act as an indicator of the outside energy flowing through the Cell. When the Cell is running correctly, the flow of outside energy is sufficient to keep the water in its conditioned state without the need for any external electrical supply. It also maintains its own energy flow through the Cell. There is no point in proceeding any further until the Cell has reached its self-sustaining condition. If it is not happening for you, check out the information in the "workarounds" section below and if that does not get your Cell operational, ask for advice and assistance through the Yahoo groups mentioned above.

Some people concern themselves with the pH of the water. The pH really is not important as the cell will take up the correct pH as conditioning proceeds. A cell of the type described in this document, will have water which is very slightly acid with a pH of about 6.5, but it is not important to know this or to measure it. Do not put litmus paper in the cell water as that will contaminate the cell. Just rely on the action of the bubbles to determine how the cell conditioning is progressing.

Installing the Cell in the Vehicle

When the Cell has reached its self-sustaining condition, it can be mounted in the vehicle. The first step is to insulate the Cell from the engine components. This insulation is not just electrical insulation which is easily accomplished, but it is a case of introducing sufficient separation between the Cell and the engine to stop the

concentrated (invisible) energy leaking away instead of being fed to the engine through the aluminium tube. So, wrap the Cell walls in three layers of double-laminated hessian sacking ("burlap"), pulling it tightly around the 5-inch diameter outer tube. Tie (a minimum of) three wooden dowels along the length of the Cell and bend the mounting bracket around the dowels. The purpose of this is solely to ensure that there is at least a three quarter inch air gap between the walls of the Cell and everything else, including the mounting bracket:

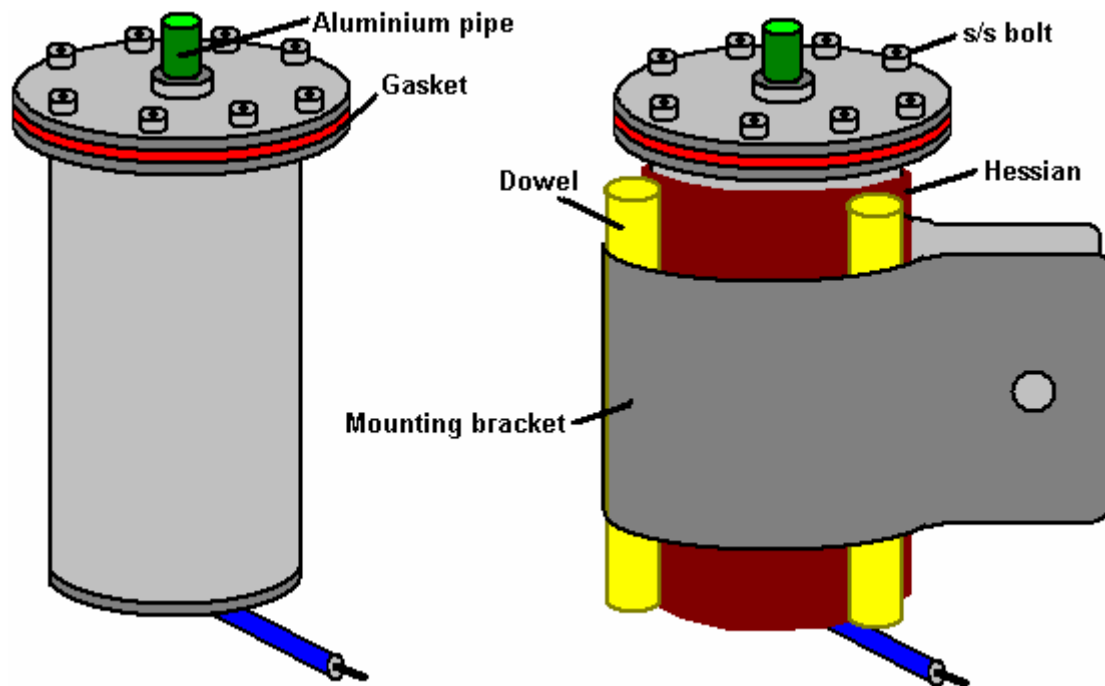

The mounting details depend on the layout of the engine compartment. The really essential requirement is that the aluminium pipe running to the engine must be kept at least 4 inches (100 mm) away from the engine electrics, radiator, water hoses and air-conditioning components.

The last four inches or so, of the tube going to the engine cannot be aluminium as that would cause an electrical short-circuit between the (occasional) positive outer connection to the outside of the Cell and the engine itself which is connected to the battery negative. To avoid this, the final section of the pipe is made using a short length of clear plastic piping, forming a tight push-fit on the outside of the aluminium tube and on the connection to the intake of the engine's carburettor. There should be a 3/4 inch (18 mm) gap between the end of the aluminium pipe and the nearest metal part of the carburettor. If it is just not possible to get an airtight fit on the intake to the carburettor and a hosepipe clamp has to be used, be sure that the fitting is non-magnetic stainless steel. If such a fitting cannot be found, then improvise one yourself, using only 316L grade stainless steel.



In the installation shown above, you will notice that the aluminium tube has been run well clear of the engine components. A vacuum gauge has been added but this is not necessary. For the early stages of installation, the aluminium pipe runs to the vacuum port of the carburettor but stops about 3/4 inch (20 mm) short of it, inside the plastic tubing. This method of connection is advisable for the initial setting up of the vehicle modification. At a later date, when the engine has been running with the Cell and is attuned to it, the Cell operates better if the pipe is connected to one of the bolt heads on the engine block, again using the plastic tube and a gap between the aluminium tube and the bolt head. Some people feel that a safety pressure -release valve with a safe venting arrangement should be used if the pipe feeding the engine, terminates on a bolt head. If it is still available, the <http://www.youtube.com/watch?v=DexBoYfDoNw> video shows Bill Williams operating his Joe Cell.

Getting the Vehicle Running and Driving Techniques

The Joe Cell is not a 'turnkey' system. In other words, just building a Cell and installing it in the vehicle is not nearly enough to get the vehicle running without the use of a fossil fuel. Some adjustments need to be made to the timing and the engine has to become 'acclimatised' to the energy.

Mount the Cell in the engine compartment and connect the Cell to the battery negative. After two or three minutes, take a lead from the battery plus and touch it briefly to the lid of the Cell. This should produce a spark. Repeat this until four sparks have been produced. This 'flashing' process aligns the Cell electrically and directs the energy to flow in the direction of the metal which has been 'flashed'.

The next procedure is dangerous and should only be carried out with the greatest of care. The engine crankshaft also needs to be 'flashed' four times. This is carried out with the engine running and so can be hazardous - take extreme care not to get caught up in the moving parts. Connect the lead from the battery positive to the shaft of a long-handled screwdriver and keep your hands well clear. The procedure is to get a helper to start the engine, then arc the current to the exposed pulley on the crankshaft (where timing adjustments are made). There should be a total of four sparks to the crankshaft in a period of about one second.

Next, for three or four seconds, flash along the length of the aluminium pipe. This encourages the energy to flow along the pipe, reinforcing the natural attraction between aluminium and this energy. Remove the wire coming from the battery positive as the Cell operates with only the negative side of the battery connected (remember that this is NOT electrolysis and the cell just directs the unseen energy into the engine).

Mark the present position of the distributor cap. Loosen the bolt holding it in place and rotate it to advance the timing by 10 degrees. Disconnect the fuel to the carburettor (do not use an electrically operated valve for this). The engine will continue to run on the fuel left in the carburettor and the engine will start to cough. Turn the distributor cap a further 20 degrees (that is now a total of 30 degrees from its original position) and have your helper use the starter motor to assist the engine to keep turning.

Rotate the distributor cap to further advance the spark until the engine starts to run smoothly. There will be a gasping sound and the engine will slow nearly to a stop, then it will pick up again and then slow down. The action is wave-like, something like breathing. Fine-tune the timing to get the smoothest running and then fasten the distributor cap in place. Do not touch the Cell, but leave it undisturbed. You are now ready to drive away in a vehicle which is not using any fossil fuel.

The procedure described here may not end successfully as just described. Some cars are more difficult to get operating on a Cell than others. Experience helps enormously when getting the vehicle started for the first time. Joe mentions in the video that it has taken him a couple of days of sustained effort to get a particular car going for the first time, which is quite something considering that he has years of experience and has got many vehicles and Cells operational.

When the vehicle has been run and is operating correctly on the Cell, it is time to make the final adjustment to the set-up. For this, the pipe connection to the vacuum inlet of the carburettor is moved from there to terminate on a bolt head on the engine block. The Cell works best when completely sealed off from the air in the engine compartment and as no gas is actually being moved from the Cell to the engine, there is no need for any kind of connection to the carburettor. If the engine is a V-type, then the bolt head chosen should be one in the valley of the V, otherwise, any convenient bolt head on the head of the engine block will be satisfactory. Don't forget that the connecting pipe must still be kept well clear of the engine's electrical leads and other fittings as described earlier. Also, the 3/4 inch (18 mm) gap between the end of the aluminium pipe and the top of the bolt head must be maintained inside the clear plastic tube, and the pipe fitting should

remain airtight. A slight timing adjustment may be necessary with the new connection in order to get the very best running.

The energy which powers the engine has a tendency to run along magnetic fields. Driving under high voltage overhead power lines can position the vehicle in an area where the energy level is not sufficient to maintain the energy flow through the Cell. If the energy flow through the Cell is disrupted, then it is likely to stop functioning. If this were to happen, then the Cell would have to be set up again in the same way as for a newly built Cell which has never been used before. This can be avoided by attaching an AA ("penlight") dry cell battery across the Cell with the battery plus going to the lid of the Cell. A battery of this type has such a high internal resistance and so little current capacity that no significant electrolysis will take place on the very pure conditioned water in the Cell. But the battery will have the effect of maintaining the integrity of the Cell if it is temporarily moved away from its source of power.

Suppliers

Sheets of nitrile rubber NB70 ("Buna-n") : <http://www.holbourne.co.uk>

Nylon rod: <http://www.holbourne.co.uk>

Stainless steel tubing: <http://www.stabarn.co.uk>

A4 Bolts (316 S31 stainless): <http://www.a2a4.co.uk>

Workarounds

If it is not possible to get pipes of the desired diameters, then they can be made up by rolling stainless steel sheet and using a TIG welder with completely inert gas, to tack weld at each end and in the middle of each cylinder. Don't weld along the full length of the join unless it is the 5-inch outer casing.

If it is found to be particularly difficult to make the four circular cuts in 1/8 inch (3 mm) steel using hand tools, then I would suggest using a plasma cutter. Make a template to guide the cutting head and clamp it securely in place. You can hire the cutter and compressor quite cheaply as you will only need them for a very short time. If they are not given to you as a pair and you have to select each from a range, take the smallest cutter and a twin-cylinder compressor rated at nearly double the input quoted for the cutter. This is because the cutter is rated by the volume of compressed air, and the compressors are rated by the volume of their uncompressed air intake as that sounds more impressive.

If no lathe is available for machining the base plinth for the central cylinder, then take a piece of 16-gauge stainless steel sheet and cut the plinth out of it as shown below. Bend the projecting tags upwards by holding each tag in the end of the jaws of a vise and tapping the body section square, with a flat-faced hammer and if you consider it necessary, tack-weld the top of the tags to the outside of the central cylinder to give rigidity to the mounting. Extreme heat such as is generated by welding or cutting tends to create permanent magnetism in any ferrous metal being heated, so avoid high temperature operations such as welding wherever possible. If a tight push-fit can be obtained with the base of the 2-inch cylinder, then I suggest that the optional spot welds are omitted.

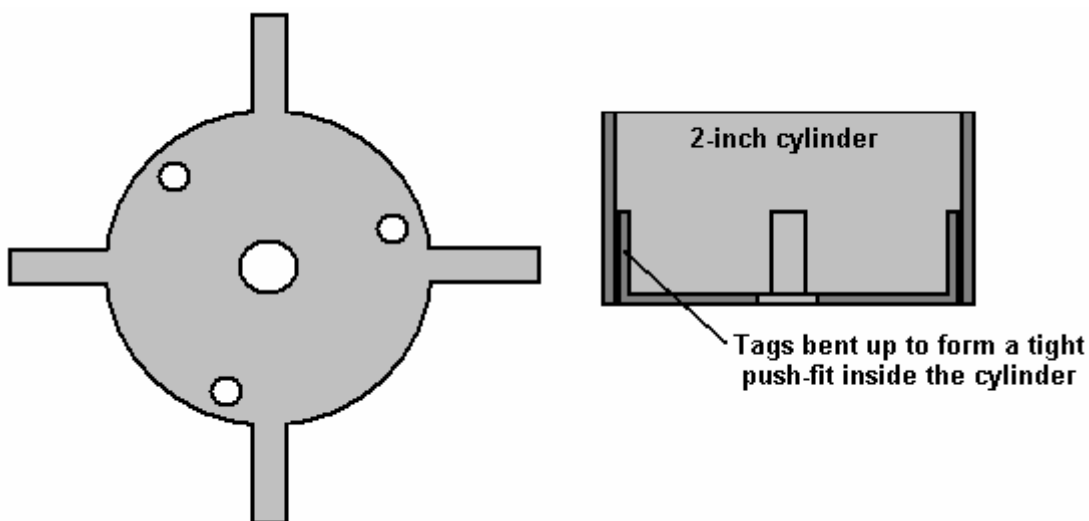

If tack-welded cylinders have to be used, then it is usually best to line all of the seams up as the seam area does not work as well as the remainder of the tube, so if the seams are all aligned, then there is only one small line in the Cell which is not operating at its optimum value.

Cylinders are best aligned in the same direction. This sounds odd as they are physically symmetrical. However, these cylinders will be used to channel an energy field and each cylinder has a direction along which the energy flows best. To find this, stand all of the tubes upright in a tight group on a table. Leave them for a minute and then place your hand on top of the whole set. If any tube feels hotter than the others, then it is out of energy alignment with the rest and should be inverted. Repeat this test until no tube feels hotter than the rest.

An alternative way to do this test is to use a pair of L-rods. These can be made from two short lengths of rigid black polythene tubing often found in garden centres for use in garden irrigation. This tubing has 1/8 inch internal diameter and so takes 1/8" brass welding rod very nicely. The welding rods should be bent with a radius as shown here:

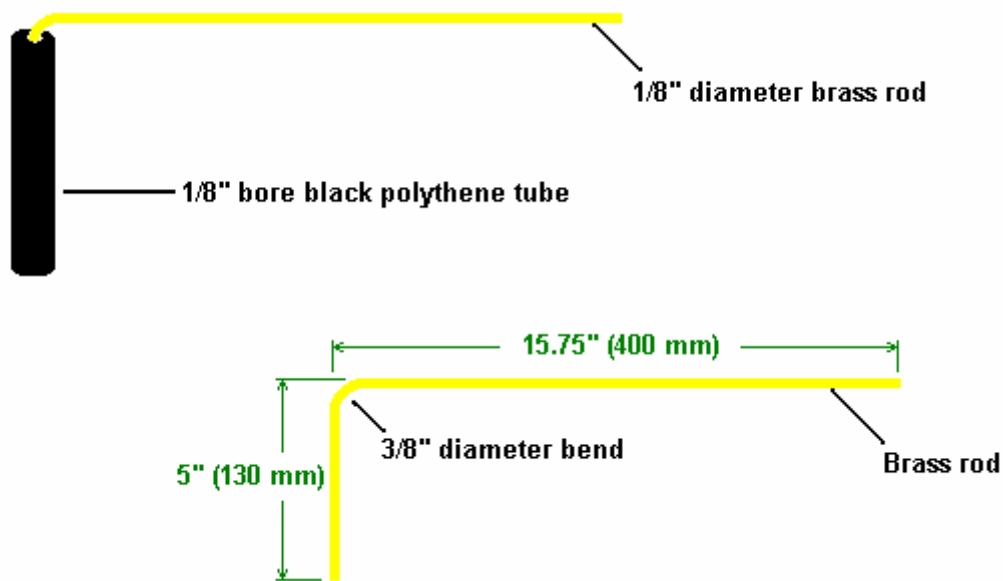

The curved bend in the brass welding rod helps to prevent the rod fouling the top of the plastic tube handle and it allows free rotation of the brass rod. It is essential that the rod can move completely freely in the handle. If two of these are made up, they can be used to check the cylinders before they are assembled for insertion into the Cell. Place a tube standing vertically on a table well away from all other objects (especially magnetic and electrical items). Hold an L-rod handle in each hand so that the rods are parallel in front of you. The rods must be exactly horizontal so as to avoid any tendency for them to turn under the influence of gravity. Approach the cylinder. The rods should either move towards each other or away from each other as the cylinder is approached.

Repeat this procedure at least three times for each cylinder so as to be sure that a reliable result is being obtained. Invert any cylinder if necessary, so that every cylinder causes the rods to move in the same direction. Then assemble the Cell, maintaining that alignment of the cylinders during the assembly.

If you are having difficulty in getting the Cell operational, then try striking and sparking the cylinders again. This is done as follows:

1. Take a 12V lead-acid battery and position it so that it's negative terminal is pointing towards East and it's positive terminal is pointing towards West (i.e. at right angles to the Earth's magnetic field).
2. Attach a lead from the battery negative to the outside of the base of the tube.
3. Lay the tube on a table and strike it with a hammer along its length. If the tube has a seam, then strike the tube along the length of the seam.
4. Connect a lead to the positive terminal of the battery and spark the inside of the top of the tube. It is essential to spark each tube if they have been polished. It is better not to polish any of the tubes.
5. Repeat this procedure for each tube.

If you consider it necessary to clean the cylinders, then, considering the lengths you went to remove all of the things dissolved in the water, be sure to avoid using any kind of chemical or solvent. You can electro-clean them by using the following procedure:

Starting with the largest cylinder;

1. Put the battery positive on the inside of the top of the cylinder, and the negative on the outside at the bottom, and leave them in place for one minute.
2. Put the negative on the inside of the top of the cylinder, and the positive on the outside at the bottom, and leave them in place for one minute.
3. Repeat step 1: Put the battery positive on the inside of the top of the cylinder, and the negative on the outside at the bottom, and leave them in place for one minute.

Do this for all cylinders, working inwards.

It has been suggested that an improved method of conditioning water to fill the Cell can be achieved if pulsed DC is used instead of straight DC from a battery. This has not been proven but there is a reasonable amount of information to suggest that this is likely. The following, most unusual circuit, has been suggested, but it must be stressed that it is untried and anybody who is unfamiliar with working with electronics should not attempt to construct or use this circuit without the assistance of a person who is experienced in building and using mains equipment.

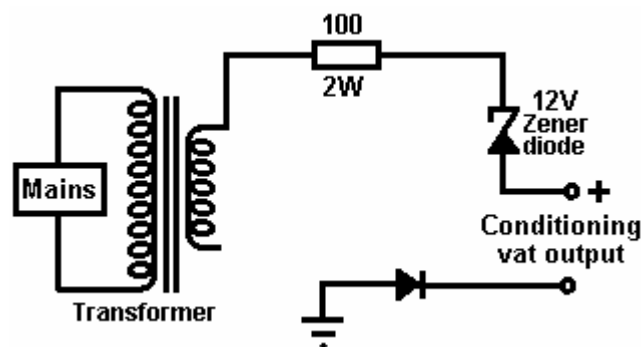

This is a most unusual circuit. A 12V step-down mains transformer provides 12V AC which is taken through a limiting resistor and a zener diode which would not normally be connected as shown. The really odd thing is that the circuit which contains the secondary of the transformer appears not to be connected. The expected output from this very odd circuit is pulsing DC of odd waveform, all of which is positive relative to the ground connection, which is a literal, physical connection to an earthing rod driven into the ground.

Notes:

Engines running while powered by a Joe Cell act in a somewhat different manner. They can idle at a very low number of revs per minute, the power available on acceleration is much greater than normal and they appear to be able to rev very much higher than ever before without any difficulty or harm.

The type of Cell described in this document was built by Bill Williams in the USA with the help and assistance of Peter Stevens of Australia. Bill describes his first driving experience with his 1975 F 250, 360 cu. in. (5.9 litre) Ford pickup:

Well, all I can say is "who needs an Indy car when you can drive an old FORD" – WOW!!!! The first five miles after leaving home were wild. I had to be extremely careful on how I pressed the accelerator. I gingerly crept up to 45 mph and that was with moving the pedal maybe half an inch. The throttle response was very crisp or touchy. With about a 1/8" of movement the next thing I knew I was close to 80 mph. If I lifted off ever so slightly on the throttle, it felt like I was putting the brakes on and the speed would drop down to 30 mph or so. "Very erratic". If I barely even touched or bumped the pedal it felt like I had pushed a nitrous oxide booster button. WOW !!!

As stated earlier, the first 5 miles were wild and things started to change. The engine started to buck or surge with very large rpm changes and literally threw me against my seat belt. It got so bad I just took my foot completely off the pedal and rode the brakes to stop the truck. The truck left skid marks on the pavement every time the engine surged in rpm. Well anyway, I manage to get it stopped and shut it off with the ignition key - thank GOD !

I retarded the timing, turned the gasoline back on, crossed my fingers and hit the ignition key, and the engine took right off, revving to maybe 4,000 rpm and then gradually decreased to 700 rpm. I took a deep breath and put it into drive and the truck responded close to normal again. I made it into work a little late, but late is better than never the way I see it. After working during the day at the job and thinking what I could do to stop this erratic rpm oscillation, I decided to disable the cell and drive home on gas. WOW !!!

Peter Stevens states that the main reason for the erratic behaviour of the Cell was due to outside air leaking into the Cell, and he stresses that Cells need to be completely airtight. It is also clear that the timing was not set in the correct position. All properly built Cells give enhanced engine power.

Water Conditioning:

Note: With the Cell design shown later, no water conditioning is needed. Please be aware that water quality and purity varies enormously from place to place. One experienced cell builder says: I use water taken from the start of rivers. Further down the river, the water will have encountered influences which are not helpful. My favourite water catchment area well is outside Melbourne, Australia, where there are no roads, power lines, dams, pipes or any man made intrusions, the water flows how and where it wants to in natural, twisty downhill paths it has created, the whole area is green all year round and you can feel the vitality and Nature at work.

This water has a pH of 6.5. That means it is slightly acidic, and perfect for Joe Cells. I bring this water home making sure that I protect it from excessive sloshing and the heat of the sunlight whilst in the car. At home, I store it in 20 litre Pyrex bottles. Do not store it in plastic containers even if the container is marked "suitable for water". Earthenware or wood containers would also be very suitable.

I make an electrolyte solution by dissolving 500 grams of food-grade phosphoric acid and 100 grams of sodium perborate, in three litres of de-ionised water or distilled water. Just a few drops of this solution will provide a current of 1 amp at 12 volts in the conditioning vat. An alternative is to use a 90% acetic acid solution which has no stabiliser in it.

When conditioning the water in the cell, you will need a lid, or some way of sealing of the cell from air. A lid loosely sitting on top of your test jar is sufficient. The seeding and breeding process is hampered by having too great an area of the top of the cell being exposed to air. All lids are not the same as regards to being a obstruction to orgone. If the lid does not seem to be working, place a layer of aluminium foil underneath the lid and use the foil and lid as one unit.

The aim is to modify the conductivity of the water by the addition of acid, so as to get a suitable current flow. If we used de-ionised water with a pH of 7.0, we would have a very low current flow for our electrolysis, and would have to add something to increase the conductivity of the water if we wanted observable results in a short period of time. As we lower the pH, the current flow and electrolysis process will increase together with a heat increase.

We are trying to achieve electrolysis action with the minimum heat generation. As the propagation of orgone is reasonably slow, there is not much to be achieved with excessive current. Slow and steady does it. For the patient experimenter or one that is using neat water, i.e. water without electrolyte, excellent results are achieved with currents as low as 50 milliamps.

The procedure is:

1. Place your cell on a wooden work bench or on a sheet of plastic type material or, as a last resort, on a newspaper. We are trying to insulate the cell from metal paths that may impede the seeding process. Keep the cell well away from electrical sources such as a television set, refrigerator, electric cooker, etc.
2. With a multimeter, measure the resistance between the innermost and the outermost cylinders of your cell. It should be in the high Megohm range. If not, the insulators are conductive or there is a short-circuit. Check for a short-circuit and if there is none, remove the insulators and reassemble the set,

checking the resistance between the innermost and outermost cylinders as each cylinder is added. The resistance between every pair of cylinders should be very high.

3. When all is okay in the above step, fill the cell using a funnel containing a paper coffee filter. Fill it only to a level just under the top of the cylinders and no more. The effect that we want to create is a set of water cells separated by metal cylinders. These are your alternate organic and inorganic chambers. Of course, the submerged section of your chambers are flooded, but with this simple cell, the top will be doing all the work. This is why the cylinders should be completely horizontal and true at the top, otherwise the meniscus formed by the water would not work and the water would flow from compartment to compartment. This level is only critical during the seeding process, as we require maximum orgone capture to seed the cell. Naturally, with a charged cell, the water is sloshing all over the place whilst you are driving the car.
4. Turn on the power supply, and if it is adjustable, set it to 12 volts. Connect the negative end of your power source to one end of your meter that is set up to read a minimum of 2 amps and connect the other end of the meter to the bottom of the central cylinder. Wait for two minutes and then connect the positive end of your power source to the top of the outer cylinder. What you have done is set up the meter to read any current flow into your cell from the power source.

At this stage, if your water is close to a pH of 7, as previously discussed, the current flow will be zero, or in the low milliamp region. If the current flow is amps, then you are doing something wrong! It is impossible to pass a huge current through ordinary pure water when using 12 volts. Think about it. To draw even 1 amp at 12 volts, the resistance of the water would have to be 12 ohms! No way! You are doing something wrong. Correct the problem and then move on.

5. Presuming that the current is only milliamps, you now want to introduce electrolyte to increase the current flow through the water. The aim is to get a current flow of about one amp. To do this, drip a small amount of your chosen electrolyte into the cell water whilst stirring and watching the current measurement. Use a glass, Perspex or wooden dowel rod as the stirrer - do not use your handy paint-stirring screw driver! Throw away the stirrer when finished as it will have absorbed some of the cell contents. Do plenty of gentle stirring of the water as you add the electrolyte, otherwise you will add too much electrolyte. Stop adding electrolyte when the meter indicates 1 amp. Your water level may rise as a consequence of the addition of electrolyte. Remove some water from your cell. I use a pipette, so as not to disturb the cell. Remove enough water to again just expose the top of the cylinders. At this stage, disconnect your meter and power source and have a bit of a clean up as the next stages are guided by observation.

The charging process is separated into three distinct stages which are called Stages 1, 2 and 3. These stages have both some obvious differences and some subtle ones. For the rest of the charging process, you will be only connecting your power source to the cell for a maximum of 5 minutes at a time. As orgone lags electricity by about 30 seconds, you will know the state of the cell in less than a minute. Do not be tempted to leave the power connected to the cell for long periods! Yes, I know that you are in a hurry and more is better, but in this case you only generate heat, steam, waste power and overheat the cell. You can pick the failures by seeing their cells running non-stop for days with 20 or more amps turning the water to steam, etching the cylinders and ending up with a barrel full of scum. What else would you expect? After all, electrolysis is time and current related. If you have had the misfortune of having your cell left on for a long period with high current, you have probably destroyed your cylinders. You cannot retrieve the situation so throw the cell away and start again. I bet you don't do it next time!

Danger: Do **not** charge any cell that is totally sealed! The cell will explode, with all the resulting consequences. An airtight seal **is not required**! At no stage do I prescribe any form of airtight container.

Stage 1: This stage is plain old electrolysis. Due to passing direct current through a liquid which contains ions, chemical changes will occur. In our case, you will see small bubbles and a cloud of activity that is greater nearest the outside of the innermost negative cylinder. The important observation points are that the activity is greatest nearest the central cylinder and gets progressively less as we move outward via the different chambers formed by the rest of the cylinders. Also, within a short period of turning the power off, all activity stops, the water becomes clear and the bubbles disappear.

Every fool and his dog can reach Stage 1. The secret for progressing further is to restrain your impatience and not increasing the electrolyte concentration to raise the current (and/or leaving the cell on for days on end). Be patient, leave the cell on for no longer than 5 minutes, turn the power source off, remove the leads to the cell, and put the top on the test cell, or partially block off the exit of the car cell. It does not have to be

airtight! Go and do something else. It is like waiting for a tree to grow from the seed. Do this on a daily basis for days, or a week, or longer, until you get to Stage 2. You will find that the more "alive" the water is, the quicker is the seeding of the cell. I have found that the storage, age, and source of the water all affect the seeding speed. I have also found that by changing the structure of the water by various means e.g. vortexing, shaking, filtering, etc., you can greatly enhance the water quality to make it more "alive".

Stage 2: You will now notice on your initial powering up of the cell, that the bubbles are getting larger and the white cloud of tiny bubbles in the water are much smaller or more transparent. Also in Stage 1, you had the action occurring mainly near the central cylinder. Now the bubbles form in a regular fashion irrespective of their location in the cell. More importantly, on turning the power off from the cell, the bubbles do not go away immediately but stay there for minutes rather than seconds as in Stage 1. Also, the top of the water assumes a glazed look and the meniscus is higher due to a change in the surface tension of the water. At this stage you may have some brownish material amongst your bubbles. Don't panic - it is only the impurities being removed from the cell. I find that if I wipe the top surface of the water with a paper towel, the bubbles and the deposit will adhere to the paper and can be removed easily. Top up the cell with water from your charging vat, if required, after the cleaning, so that again, the top edges of the cylinders are just showing. No more electrolyte is added! In cleaning the top of the cell as described, it has been observed that some people react unfavourably with the cell. If so, keep that person away, or if it is you, try changing your hand i.e. use your right hand instead of your left or vice versa. If the presence of your hand seems to collapse the surface bubbles, I would suggest you get a friend to do the work for you.

Summary of Stage 2: The result is very similar to Stage 1, but now we have a more even bubble distribution and an increase of surface tension and a longer presence of the bubbles when the power is turned off. There will be no scum in the bottom of the cell and the water will be crystal clear. At this stage the orgone has seeded the cell, but as yet, is not "breeding", that is, the orgone concentration is not yet great enough to attract additional orgone flow to itself. With the right cell, water and operator, it is possible to go straight to Stage 2 on the first turn on of a new cell.

Stage 3: Not many people get to this stage, or what is worse, get here incorrectly. If you get here following the above steps, your water is still crystal clear with no deposits in the sump. If you get here by brute force, you will have stripped appreciable amounts of material from the cylinders and this material will now be deposited on the insulators and suspended in the water as tiny particles which never settle out, and finally, the material will form a deposit at the bottom of the cell. The low resistance insulators and the metallic particles in the water will create a cell which leaks orgone and consequently it will cause endless mysterious car stoppages or refusals of the car to start.

Right, the miracle of Nature is now breeding in your cell. Upon turning your power on to the cell, within 30 seconds copious beautiful white bubbles will rise from all the surface area of the cell. Before these bubbles cover the water surface, you will notice a slowly rotating and pulsing front in all cylinders, that is synchronised and has a regular rhythm of about 2 pulses per second and a clockwise rotation speed of about 1 revolution every 2 seconds. These effects are very hard to observe for a first time viewer who does not know what to look for. I find it easier to watch these effects with the aid of a fluorescent light, as the 100 cycles per second pulsations of the light "strobe" the water surface and help the observation.

The bubbles may overflow the container and show great surface tension. One of the definite proofs that the cell is breeding is that, on turning the power source off and coming back the next day, most of the bubbles will still be on top of the water as opposed to Stage 1 or Stage 2 where they disappear in minutes. There is no way that you can mistake this stage. The bubbles are larger and pure white, the surface tension is greater, the bubbles are pulsating and most importantly the surface tension remains days after the power has been removed.

I do not recommend any additional tests or measurements. But for those who are incapable of leaving things be, they may measure the voltage across the cell after it has been left standing with the power off for at least 24 hours. A Stage 3 cell will have a residual voltage, or more correctly, a self-generated voltage of around 1 volt. A Stage 1 cell measured under similar conditions will read 0.1 to 0.2 volts. Remember, that unless you know what you are doing, these voltage measurements can be very misleading due to probe materials and battery effects that can easily mask your true measurement. As the cell reaches the maximum density of orgone that it can hold, the result of the breeding process is the conversion of this excess orgone into the formation of electricity. As such, electrical measurement with the correct instruments is a very valuable method in the verification of the efficiency of the cell. If you are conversant with the work of William Reich, you may care to make an orgone meter and thus remove all guesswork. This meter is fully described on some web sites.

I do not recommend any form of bubble exploding. As noted earlier, noise and vibration are orgone-negative. Therefore, these explosions applied during the delicate seeding period will kill your cell. Apart from a dead cell, the chance of fire igniting other gasses in the workshop and injuries to the ears etc. makes this exercise highly unnecessary. I must admit that I too fell for the "go on, ignite it!" feeling. I had a cell that had been at Stage 3 for seven months. It was my favourite test cell. My hands and matches fought my brain and they won. There was a huge "ear-pulling, implosion/explosion", and yes, I killed the cell. It went back to Stage 2 for four days. I will not do it again.

As all water we are using so far has been electrolysed, this water is not suitable for use in non-stainless steel or glass containers due to reaction with the container and the resultant corrosion, but if you have to, or want to, you can use juvenile water with no electrolyte added and still charge it to Stage 3. As the ion count is much lower, the water is not as conductive, i.e. you cannot get as much current flow with 12 Volts as you would if you electrolysed the water. However, if you obtain a power supply of approximately 60 to 100 Volts at about 1 Amp, you will be able to charge "plain old ordinary water". The down side is the additional waiting, in some cases, over 3 weeks, and the cost of the fairly expensive power supply. The advantage is that you will be able to pour it into the radiator of a car with no increase in corrosion as compared to water containing acids.

Do not at any stage short circuit, i.e. join any of the cell cylinders to each other electrically with your charging leads, wedding ring, etc. If you do, the cell will "die"! Your only option, if this occurs, is to connect the cell to your power source and see if you are still running at Stage 3. If the cell does not revert to running in Stage 3 mode within 1 minute, your only option is to completely dismantle the cell and re-clean and re-charge. Huh???, you are kidding us, right??? No, I am serious, that is your only option! So do not do it, do not short out your cell! You will have similar, but not as severe problems if you reverse your leads to the cell.

When the cell is running at Stage 3, you can tip the charged water out of the cell into a glass container and clean, adjust or maintain your now empty cell. Try to keep all cylinders in the same relation that they were in before you dismantled the cell, i.e. keep all cylinders the same way round and in the same radial alignment. This is mainly relevant when dismantling cells over 6 months old as the metal parts develop a working relationship that can be weakened or destroyed by careless re-assembly.

When finished, pour the charged water back and you are back in business. Of course you can pour this charged water into other cells, or use it as you see fit, but, remember, do not leave it out of the cell for periods longer than 1 hour at a time as the breeding has now stopped and you are slowly losing charge.

[Troubleshooting](#)

It is usually quite difficult to get an engine running from a Joe Cell. Many people find it difficult to get their Cell breeding ("at Stage 3"). The following suggestions from various experienced people who have succeeded are as follows:

1. The metal construction of the Cell needs to be of stainless steel and nothing else. Using copper or brass, even for something as simple as the connector between the Cell and the aluminium tube running to the engine is sufficient to cause serious problems as the energy is not directed to the engine and just leaks away sideways.
2. The water is best charged in a separate vat which has a larger capacity than the Cell itself. That way, when the Cell is being conditioned and scum removed from the surface of the water, the cell can be topped up with charged water from the vat. If, instead, ordinary, uncharged water is used, then the whole process is liable to be put right back to square one.
3. Be very sure that the mounting in the engine compartment is electrically insulated from the engine and chassis and be sure that there is serious clearance between the Cell and everything else. Also, the aluminium pipe running to the engine **must** be kept at least four inches (100 mm) clear of the main engine components. Otherwise, the energy which should be running the engine, will leak away sideways and not reach the engine.
4. It can take up to a month to get a steel engine acclimatised to a Cell. Run the engine as a "shandy" where fossil fuel is still used but the Joe Cell is also attached. This usually gives greatly improved mpg, but more importantly, it is getting the engine metal and cooling water 'charged' up ready for use with the Joe Cell alone. Once per week, try advancing the timing and see how far it can be advanced before the

engine starts to ping. When the timing gets to a 20 or 30 degree advance, then it is time to try running on the Joe Cell alone.

5. Finally, having conditioned the Cell, the water, the engine and the coolant, if there is still difficulty, then it is probably worth conditioning yourself. Both the idea and the procedure sound like they have come from Harry Potter's classes in Hogwarts School of Witchcraft and Wizardry. However, there is a serious scientific basis behind the method. Use of the Bedini battery-pulsing devices shows that lead/acid batteries act as a dipole for Radiant Energy. Also, the energy flow which powers the Cell appears to move from West to East. Bearing those two facts in mind, makes the following rather bizarre procedure seem slightly less peculiar:

- (a) Get a car battery and position it so that it's terminals line up East/West with the negative terminal towards the East and the positive terminal towards the West (along the main energy flow line)
- (b) Stand on the North side of the battery, facing South.
- (c) Wet the fingers of your right hand and place them on the battery's negative terminal (which is on your left hand side).
- (d) Keep your fingers on the terminal for two minutes.
- (e) Wet the fingers of your left hand. Place your left arm under your right arm and place the fingers of your left hand on the positive terminal of the battery. Do not allow your arms to touch each other.
- (f) Keep the fingers of your left hand on the positive terminal for three minutes.
- (g) Remove your left fingers from the positive terminal, but keep the fingers of your right hand on the negative terminal for another 30 seconds.

This procedure is said to align your body with the energy flow and make it much easier for you to get a Cell to "Stage 3" or to get a vehicle engine running. In passing, some people who suffer continuing painful medical conditions state that they have got considerable pain relief from this procedure.

Recent Joe Cell Developments.

One of the greatest problems with using a Joe Cell has been to get it operational. The reason for this has probably been due to the lack of understanding of the background theory of operation. This lack is being addressed at this time and a more advanced understanding of the device is being developed. These design dimensions cause ordinary tap water to go immediately to the fully functional "Stage 3" and remain in that state indefinitely, the only way of stopping the Cell is to physically take it apart.

While it is still rather early to draw hard and fast conclusions, a number of results indicate that there are three separate, unrelated dimensions which are of major importance in constructing a properly "tuned" Joe Cell. It needs to be stressed that these measurements are very precise and construction needs to be very accurate indeed, with one sixteenth of an inch making a major difference.

The dimensions are specified to this degree of accuracy as they represent the tuning of the Cell to the frequency of the energy which is being focussed by the Cell. The fact that there are three separate dimensions, suggests to me that there are probably three components of the energy field, or possibly, three separate energy fields.

These three dimensions have been assigned names and are as follows:

Golden dimension: 1.89745" (48.195 mm)

Blue dimension: 3.458" (87.833 mm)

Diamagnetic dimension: 0.515625" (13.097 mm)

It is suggested that a Joe Cell should be constructed with cylinder heights which are a multiple of either the 'Golden' or 'Blue' length. Also, the water height inside the container should be below the tops of the inner cylinders and be a multiple of the basic length chosen for construction. The inner cylinders should be positioned the 'Diamagnetic' dimension above the base of the Cell. They should also be constructed from stainless steel of thickness 0.06445" (1.637 mm, which is very close to 1/16") and there should be a horizontal "Diamagnetic" gap between all of the vertical surfaces.

The inner cylinders should be constructed from stainless steel sheet which is tack welded at the top and bottom of the seam, and all of the seams should be exactly aligned. The lid should be conical and sloped at an angle of 57° , with its inner surface matching the inner surface of the housing and the inner surface of the outlet pipe. The outer casing should not have any dome-headed fasteners used in its construction. The length of the outlet pipe should be made of aluminium and should be 15.1796" (385 mm) for 'Golden' height cylinders or 20.748" (527 mm) for 'Blue' height cylinders. That is 8H for Golden and 6H for Blue and should there be a need for a longer pipe, then those lengths should be doubled or tripled as the single dimensions no longer apply (this being a fractal effect). At this point in time, these are only suggestions as the science has not yet been firmly established. One possible arrangement is shown here

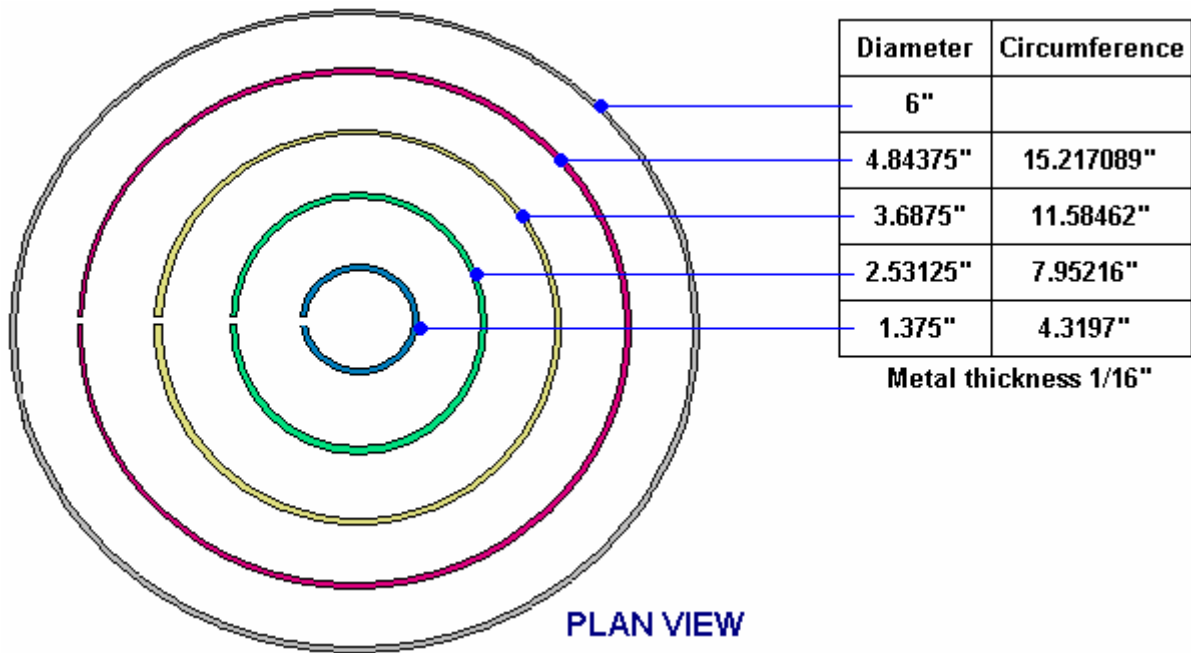

It is not necessary for there to be four inner cylinders so an alternative might be:

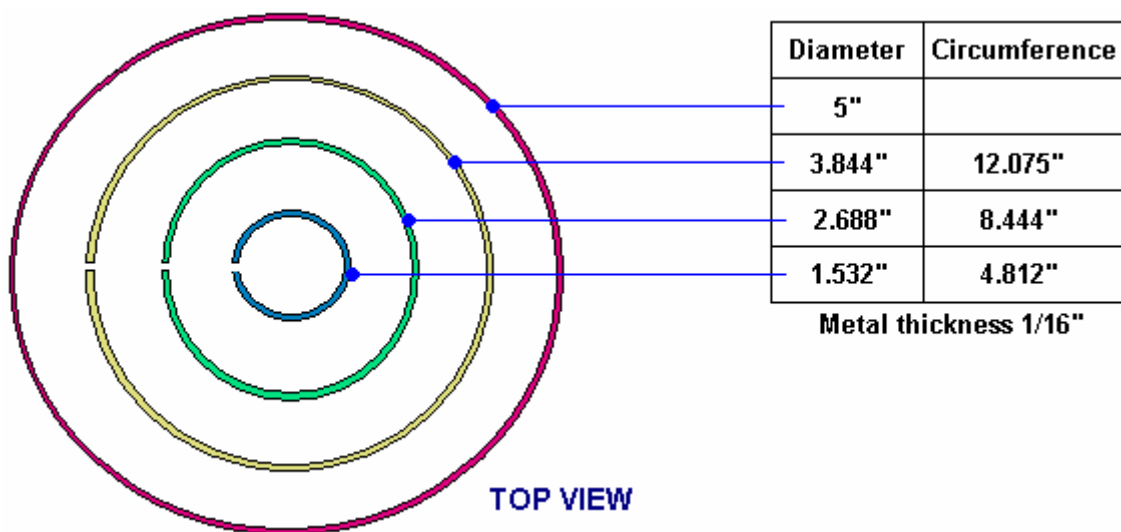

A suggested Joe Cell design is shown below. This diagram shows a cross-section through a Joe Cell with four inner concentric stainless steel tubes. These tubes are positioned 0.515625 inches (13.097 mm) above the bottom of the Cell and the gap between each of the tubes (including the outer casing) is exactly that same 'Diamagnetic' resonant distance.

It should be clearly understood that a Joe Cell has the effect of concentrating one or more energy fields of the local environment. At this point in time we know very little about the exact structure of the local environment, the fields involved and the effects of concentrating these fields. Please be aware that a Joe Cell which is properly constructed, has a definite mental / emotional effect on people near it. If the dimensions are not correct, then that effect can be negative and cause headaches, but if the dimensions are correct and the construction accurate, then the effect on nearby humans is beneficial

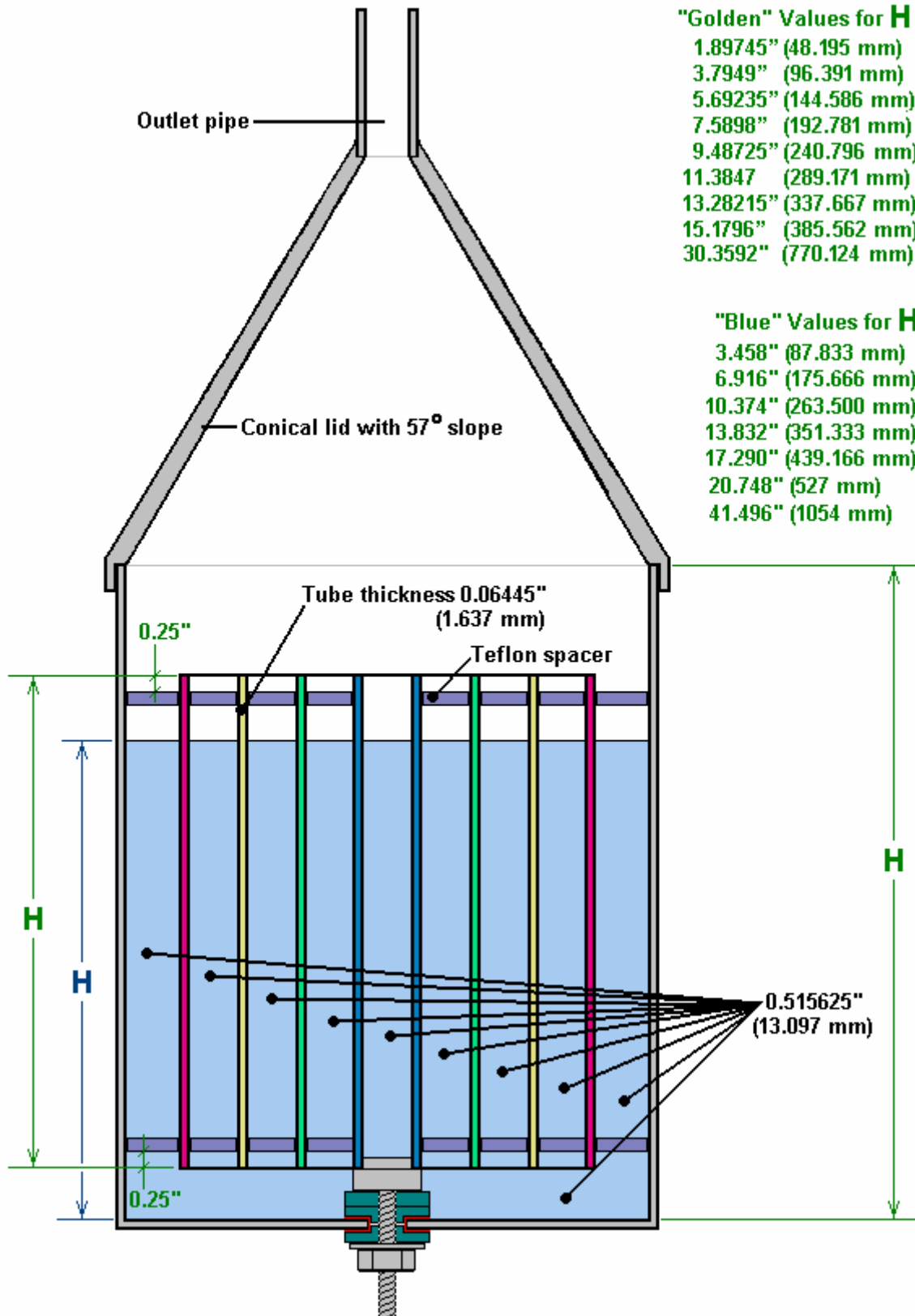

It should be pointed out that Joe Cells will be constructed with the materials which are readily to hand and not necessarily those with the optimum dimensions. If picking stainless steel sheet which is not the suggested optimum thickness, then a thinner, rather than a thicker sheet should be chosen. In case the method of calculating the diameters and circumferences of the inner cylinders is not already clear, this is how it is done:

For the purposes of this example, and not because these figures have any particular significance, let's say that the steel sheet is 0.06" thick and the outer cylinder happens to be 4.95" in diameter and it is 0.085" thick. People wanting to work in metric units can adjust the numbers accordingly where 1" = 25.4 mm.

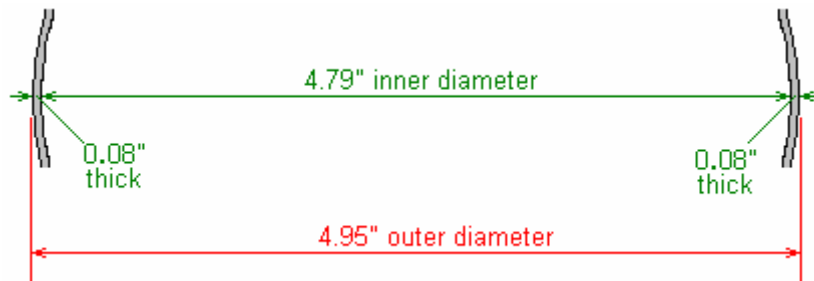

Then, the inner diameter of the outside cylinder will be its outer diameter of 4.95", less the wall thickness of that cylinder (0.08") on each side which works out to be 4.79".

As we want there to be a gap of 0.516" (in practical terms as we will not be able to work to an accuracy greater than that), then the outside diameter of the largest of the inner cylinders will be twice that amount smaller, which is 3.758" :

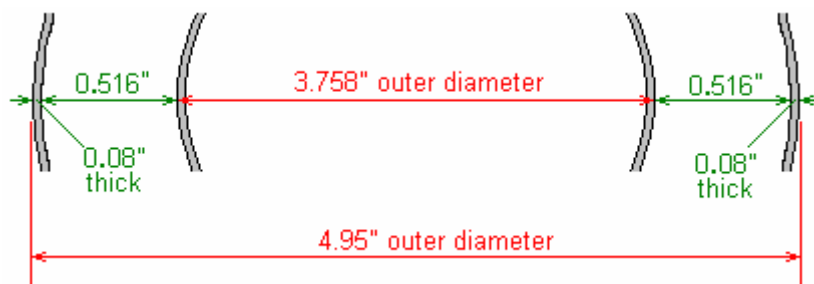

And, since the material of the inner cylinder is 0.06" thick, then the inner diameter of that cylinder will be 0.12" less as that thickness occurs at both sides of the cylinder, which works out to be 3.638" :

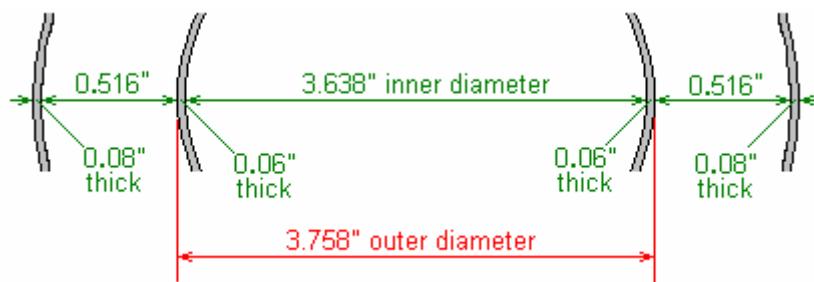

The length of stainless steel needed to form that cylinder will be the circumference of the outer diameter of 3.758" which will be $3.758" \times 3.1415926535 = 11.806$ inches.

The dimensions of the other inner cylinders are worked out in exactly the same way, bearing in mind that every steel thickness is 0.06". The results for three inner cylinders would then be:

Diameter	Circumference
4.95"	
3.758"	11.806"
2.606"	8.187"
1.454"	4.568"

OR

Diameter	Circumference
125.7 mm	
95.5 mm	299.9 mm
66.2 mm	208.0 mm
36.9 mm	116.0 mm

Comments from an expert in July 2012:

That information is really ancient history and it was Dave's best guess at optimising a cell at that time. Later testing left us disappointed with the 'Blue' lengths, however the 'Golden' lengths make a very nice cell, but not one which is particularly good with an internal combustion engine but one which is better as a learning tool, or for use in healing.

We are into an entirely different approach now, one which entails introducing specific vibrations into the cell. An optimum implementation involves cutting each tube to a specific length so as to make it self-exciting, but that's not necessary because the frequencies can be introduced just using a caliper, or a precise length of metal touched against the tubes in a sequence. Since this approach was totally different from traditional Joe Cell work, we set up a discussion group specifically for it: http://tech.groups.yahoo.com/group/vibrational_combustion_technology/

The nice thing about this approach is that it's ultra stable. Once the vibration is set up the only way to stop it is to take the cell apart. This construction method totally eliminates the human influence factor problem! In fact, a cell can affect the engine even without there being water in the cell. Another nice thing about it is the mathematical design process is implemented in a couple of spreadsheets. My thinking at this time, is that we now need to incorporate specific engine parameters into the design to tune the cell to a particular engine.

We have been a bit sidetracked lately and have been working a lot on the healing aspects of Torsion fields: http://groups.yahoo.com/group/awaken_to_vibration/ but I hope to get back into engine testing soon.

Advances in 2011. In an effort to develop a device to emulate the function of a Joe cell without it's inherent stability issues, Dave Lowrance came up with the idea of a set of 3 concentrically-wound torsion field coils. In early testing it has become apparent that a field **is** being generated, as demonstrated by their effect on two test engines, even with no power being applied to the coils.

This is the very early stage of the investigation so this initial design is being released with the hope that others will wind and test similar coils and report their results to the appropriate groups, so that we can learn more about them through further experimenting on a variety of different engines.

The initial set of coils were wound on 7/8" (22 mm) diameter stainless steel tubing which happened to be to hand. The use of stainless steel is not significant and two successful replications have used half-inch (12 mm) PVC plastic pipe, as using a non-ferrous material is the main requirement.

The wire diameter has an effect and while 20 gauge (0.812 mm diameter) enamelled copper wire was used for the coils shown here, coils wound with 12 gauge (2.05 mm diameter) copper wire work much better and it is now thought that the weight of copper in the winding is important.

For the first layer, a length of 311 cm is used and wound on the former in a clockwise direction. The ends of the wire are secured with tape, leaving three or four centimetres of wire exposed at each end of the coil, for connection purposes. This is the first layer wound and secured:



The wire for the second layer is cut to a length of 396 centimetres. This second coil layer will be longer than the first layer, so before winding it, it's necessary to build up the area at both ends of the first layer with tape:

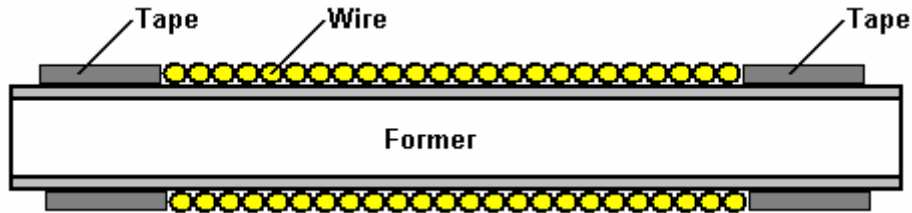

This is so that the second layer of wire will have the same diameter along its entire length. It is probably a good idea to completely cover the first layer of wire with tape to ensure good electrical insulation.

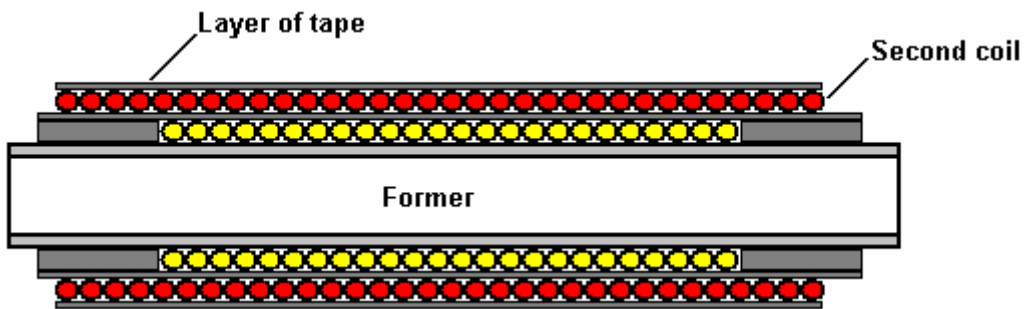

The second wire layer is also wound in a clockwise direction:

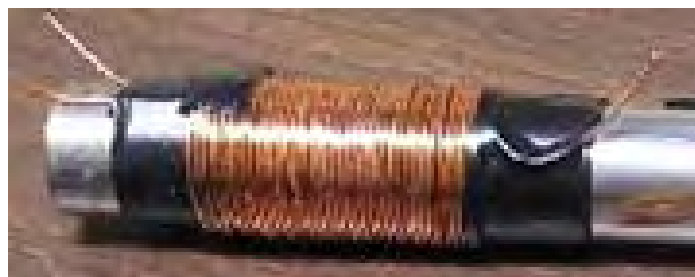

The wire for the third layer is cut to a length of 313 centimetres. Since it will be covering less length along the former, there is no need to build up the ends of the earlier layers. So, simply cover the second winding with tape, and then wind on the third layer, but this time, the coil is wound in a counter-clockwise direction and then the entire coil is covered in tape to protect it.



To be sure that the second and third layers are centred over the earlier layers, it is a good idea to locate the centre of the wire and start winding from the middle outwards in both directions:

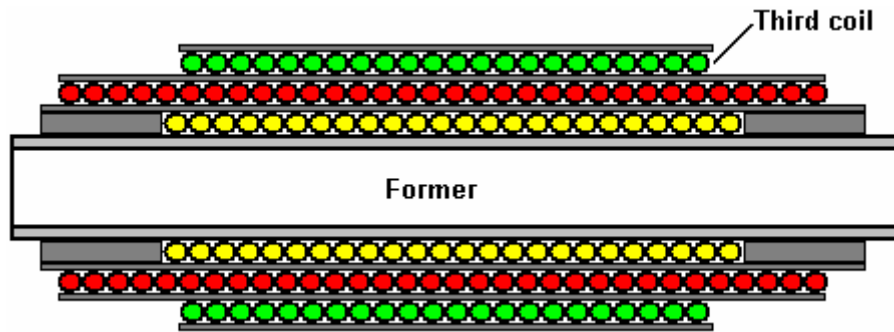

It has been found that one end of the centre winding is similar to the centre tube of the Joe cell, and the opposite end of the outer winding functions like the canister of a Joe cell. In theory, this can be tested by connecting a small capacitor between these two points, and checking for a low DC voltage using a digital voltmeter. Like a Joe cell, polarity is really the important issue to test for, since we do want the positive polarity end to transfer the energy, and the negative polarity end to be connected to engine ground. If the polarity is wrong, simply use the opposite ends of both coils.

In the testing the negative end was connected to chassis ground, and the positive end to a Hull-effect type oil probe already installed in each test vehicle. The oil probe is Robert Hull's contribution to this technology. He found that if you apply a torsion field to the oil, it will charge up an engine in a way similar to a Joe cell, but more consistently than a Joe cell would. There are two basic types of Hull-effect probe - the simplest is just a wire inserted down the dipstick tube. However, the preferred method is to remove the oil-pressure sensor and insert a T-fitting, then slide an insulated stainless steel rod into the high-pressure oil at that point. By using an oil probe, one can eliminate the aluminium transfer tube in favour of a length of wire.

The experimenter who wound the 20-gauge coils then wound a larger diameter set using 12-gauge wire on a 1.5-inch (38 mm) diameter former. He fitted these over the original set and connected just two wires, one end of the innermost of the six coils and the opposite end of the outermost coil. This gave about a 25% reduction in the fuel used by an old Honda Accord car with an Electronic Fuel Injection system.

Fuel-less operation has not yet been achieved, but that could just be a matter of getting the engine set up properly. Some of the issues we need to deal with are things like antifreeze, which destroys the dielectric properties of water, and inhibits it from charging up. This has never been discussed, but it is one of the key things which limited the ability of people to succeed with their cells. Oil is a similar issue. Some oils, particularly the ones with all the additives and detergents, simply won't charge up.

There still needs to be a lot of testing done. For instance, with this setup it might be better to connect one end of each coil to ground. Or possibly the coils would do better if the windings were all connected in series. This is all uncharted territory! Dave's original concept was to use a set of these coils to replace each tube of a Joe cell.

The engine from an old Pinto car is also being used as a test bed. Attempts were made to run it completely fuel-less. It would kick repeatedly, but just wasn't quite there. It would only kick at a very specific timing setting - somewhere between 50-60 degrees before Top Dead Centre. The Pinto has antifreeze and with just water it's more likely to run fuel-less. But that should be a last-resort option, since most people do need antifreeze.

Devices such as the Joe cell tend to work really well on engines which have a carburettor because the spark timing can be adjusted quite easily. They work well on older EFI engines (probably those prior to OBD2) but they can be a real problem on the newer EFI models as they are liable to cause a fuel injection error state to be reached almost immediately. The newer ECUs control everything so tightly that they are almost impossible to work with (which was probably a design objective of the ECU design).

The Pinto engine had not been started for over six months. No T-field devices were connected to the engine during this period, so we can assume that there was little or no residual charge on the engine. The cooling system had only water in it. The crankcase was filled with NAPA brand 30-weight oil. We fiddled with the engine to get it started. At that time the car had a little motorcycle carburettor on it, rather than the stock carburettor and the timing was set quite a bit advanced.

After just a few minutes of idling we realised that the engine was getting extremely hot with the exhaust manifold glowing red. So we shut it down. Being the optimist that I am, we went ahead and connected the coils at this time.

The next morning I took a little compass and found that it didn't point to North anywhere within about 2 feet of the car body - a very good sign! So we went ahead and started it up, and carefully monitored the head temperature with an infra-red thermometer. The temperature rose slowly to about 170 degrees F which is a little below normal. After verifying that the temperature held steady at that value, I tested with the compass again, and now it was messed up out to about 10 feet from the body. So the field strength had jumped up about 500% after starting the engine.

We then played with the carburettor and timing to get the smoothest operation at the lowest RPM at which it would idle smoothly. The RPM appeared to be well below a normal idle RPM., and when I went back and checked the timing, it was very close to 60 degrees before Top Dead Centre. At this point everything was looking so good that we tried a few attempts at fuel-less operation, but the engine died each time.

Due to pressure of other work, the car was ignored for a couple of months. When I finally got back to doing a little further testing, I found it surprisingly easy to get it started again. I didn't have to reset the timing to get it running. It actually started up with little effort, which was amazing, since the timing was still way advanced. It should be nearly impossible to start an engine with the timing set like that. The spark is just occurring at the wrong time in the cycle so it should try to push the pistons in the wrong direction.

Anyhow, it was starting to get cold here, so I decided to install some antifreeze, and that just set everything way back. It reduced the field strength by over 80%.

Since then Dave has come up with a coil-set designed to charge up antifreeze, but I was disappointed when I tried it. It did better with the antifreeze than the original set did, but we came to the conclusion that the antifreeze destroys water's diamagnetic properties to the point that the mixture is just hard to charge up. Working on this problem is the reason why I didn't release the coil info sooner. I kept hoping that we might solve this problem as well, but we didn't. However, this just might not be as big a problem as I thought, because I've heard that well-charged water just might have a significantly lower freezing point. This has not been tested yet to verify it.

An interesting side issue is the fact that the water which I drained out when adding antifreeze, showed no sign of rust. It was perfectly clear. Under normal circumstances, with no additives in the cooling system, this water should have been a horrible orange mess. It wasn't, and that has to be because of the field on the engine.

The Pinto is not roadworthy, so I have no way of knowing what kind of fuel consumption is possible with this setup or what power it might be capable of producing. At this time, I just use it to test different devices, and to try for fuel-less operation. However, if I was to achieve a consistent, repeatable fuel-less operation, it could become roadworthy very quickly, so I could do some actual road testing.

Electrets Constructed from Co-axial Cable.

There is a device which is not widely known. It is called an "electret" and I have to confess that my knowledge of them is almost zero. Essentially, an electret is a passive device which pours out electrical energy. I do not know where that electrical energy comes from. The Wikipedia encyclopaedia has some highly technical information on the subject remarking that "tunnel ionisation" is a process in which the electrons in an atom can pass through the atom's potential (voltage) barrier and escape from the atom. In an intense electric field, the potential barrier of an atom is distorted drastically and so the length of the barrier through which electrons have to pass, decreases and electrons can escape quite easily. The atoms spoken of here, might be those of a dielectric which could form an electret.

One method which has been used in the past to make an electret, has been to alter the structure of certain types of wax. A more convenient method is to use a reel of standard co-axial cable which is the sort of cable used to connect television aerials to television receivers:



An electret of that type can produce 10,000 volts at 10 milliamps. The current flow of 10 milliamps sounds trivial and of no consequence, but that is not actually the case as the power of 10 milliamps at 10,000 volts is 100 watts, so imagine a 100 watt light bulb brightly lit and not needing any power input at all to make it shine. That is actually, quite impressive.

PLEASE NOTE THAT 10,000 VOLTS WILL KILL YOU AND INVESTIGATING A DEVICE OF THIS TYPE IS NOT FOR PEOPLE WHO ARE NOT ALREADY FAMILIAR WITH WORKING SAFELY WITH VERY HIGH VOLTAGES. MEASUREMENTS MUST ONLY BE MADE WITH HIGH-VOLTAGE EQUIPMENT. LET ME STRESS AGAIN THAT I AM NOT ENCOURAGING YOU TO MAKE OR EXPERIMENT WITH ANY FORM OF HIGH VOLTAGE DEVICE AND THAT THIS INFORMATION IS FOR YOUR INTEREST ONLY.

The arrangement with a single reel of cable is:

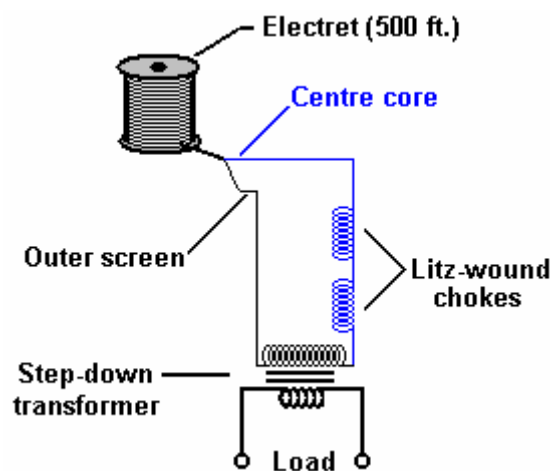

Unfortunately, life being what it is, it has been found that when you try stepping that voltage output down to a more convenient level, there are liable to be losses which can lower the output power to just 50 watts. That sounds disappointing until you put it in perspective. This is a device which has the same output as a 50 watt solar panel in full sunlight, mounted at the optimum angle and positioned near the equator, but a home installation of such a panel gives far lower output, especially so when your home is a long way from the equator. But, note that the electret costs far less, produces that full output at any latitude and at night, while the solar panel is restricted by cloud cover, distance from the equator, needs an expensive mounting system, ideally should rotate to track the position of the sun, and only works when there is a high light level. So, the electret's fifty watts of continuous power is not an insignificant thing when you compare it to the other options available. These electrets can be stacked in parallel and an output in the kilowatts range is possible.

Let me stress that I personally have not yet made or used a co-axial cable electret, and so the information here comes from an experimenter who has done this. Also, while the information here is intended to help anyone who wishes to experiment along these lines, the fact that it is here must not be interpreted as my encouraging you personally to try to make or use an electret of this or any other type. If you choose to do that, then you do so entirely at your own risk and nobody other than yourself is liable should any mishap occur.

The following procedure has been used to convert a full reel of 1/4", type RG6/U 75-ohms, 18-AWG co-axial cable into an electret:

1. Make sure that neither end of the cable has the screen touching the central core.
2. Make an electrical connections to both the screen and the core at both ends of the cable.
3. Place the whole of the spool of cable inside an oven.
4. Heat the oven (a genuine oven and not a microwave) slowly to 350°F (180°C).

5. Maintain the heat until the inner plastic insulation is so soft that it can be permanently indented. This plastic must not get too soft and reach the flowing stage, nor must it get burnt or develop holes which allow arcing - if that happens, then the reel of cable is a throwaway. The objective here is to get the plastic to lose its polarisation memory.
6. When the inner plastic sleeve has reached this level of softness, apply a steady DC voltage of about 10,000 volts to the connections already made to one end of the cable (to the screen and to the core). Although any voltage from 12V to 20,000V can be used, a 10 mA current draw can be expected when using 10,000V. Maintain this applied voltage at the high temperature for about ten minutes.
7. Turn off the heat and let the oven cool down gradually at its own rate to the 25°C to 30°C region, keeping the high voltage attached to one end of the cable.
8. Disconnect the DC voltage.
9. Connect the cable screen to the central core at both ends of the cable.
10. Leave the cable at room temperature for five to seven days. During this time, the polarisation of the plastic is reorganising. After this time, the electret is ready for use as a power source.

The Energy Boxes of Joseph H. Cater.

Joseph H. Cater has produced a most impressive body of information in his books "The Awesome Life Force" and "The Ultimate Reality". These books are expensive and as they are copyright 1984 publications, I am not allowed to provide you with a copy. Google books have a partial copy of the "Awesome Life Force" at:

<http://books.google.com/books?id=g7y6WBZWDsoC&printsec=frontcover&dq=awesome+life+force&cd=1#v=onepage&q&f=false>

and "the Ultimate Reality" at:

<http://books.google.com/books?id=ySsNiCPUPecC&printsec=frontcover&dq=the+ultimate+reality+cater&cd=1#v=onepage&q&f=false>

I have not constructed and tested the following device, nor do I know anyone who has. As the following information is not widely known, that is understandable. If you do build this device and find it to perform as described, would you please let me know as feedback of that kind is most useful.

Mr Cater describes this invention as: "a simple device which can be easily and cheaply constructed by any back yard handyman without the need for any special tools. This device can put free-energy within the grasp of everyone". Mr Cater says that this device will let any internal combustion engine run without fuel, and no changes to the engine are needed. The engine can be installed in a vehicle or used for driving an electrical generator. Mr Cater describes two different versions of this device. With either version, the larger the number of layers, the more effective the device becomes and forty layers are suggested as being a practical number. A box of sufficient size is covered with forty alternate layers of aluminium foil and paper. Two thicknesses of newspaper for each layer of aluminium foil should work well, the outermost layer being non-metallic and held in place with a generous amount of masking tape.

Version 1: The box has an air inlet and an air outlet, with non-metallic baffles between them to make the air circulate through the whole of the inside of the box. The box should have a volume of about 1.5 cubic feet (42.5 litres) and a one-inch (25 mm) flexible pipe can be used to connect the box to the air intake of the vehicle. As a box of this size will not fit in the engine compartment it can be located anywhere in the vehicle and the flexible pipe run through to the engine. Copper foil can be used instead of aluminium foil. The actual construction suggested is for a box size 12" x 12" x 18" (300 x 300 x 450 mm) constructed from acrylic and containing forty baffles.

For either version, the box needs to be robust as it has to withstand the stresses caused by the partial vacuum created by the engine's intake strokes. With metric construction using 10 mm thick acrylic, this would require two pieces 450 x 300 mm to form the top and bottom, and two pieces 450 x 280 mm for the sides, and two end pieces 280 x 280 mm. Mr Cater suggests the use of epoxy resin to join the pieces together, but the supplier of the acrylic can supply a specialist bonding liquid which makes two pieces of

acrylic merge together so that there is no actual joint as such, just a continuous piece of acrylic with a right-angle bend in it. The construction is like this:

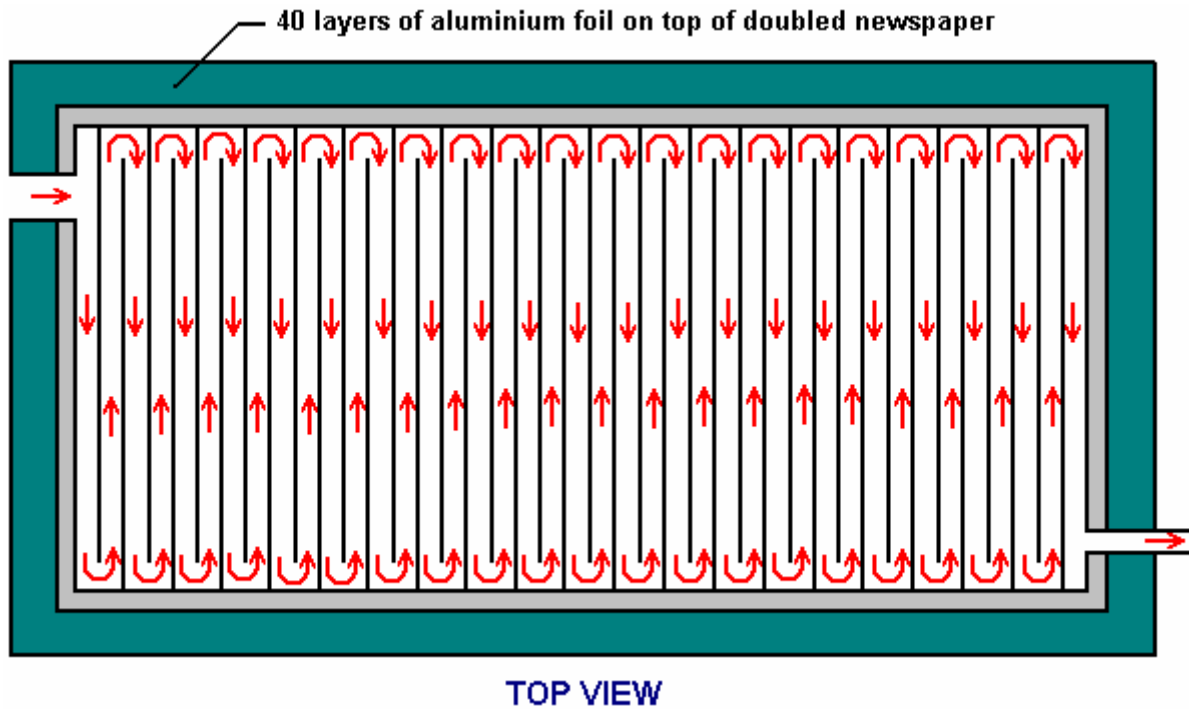

and the outlet pipe is connected directly to the carburettor if there is one, or to the air intake if there is not, so that all of the incoming air has to pass through the box. Mr Cater specifies 40 baffles inside the box and his diagram shows them running along the length of the box instead of across the width as shown above. Given the dimensions stated and lengthwise baffles, that would leave just 7 mm for an air passage plus a baffle, with 3 mm baffles that leaves only 4 mm for the air passage and while that represents an air-flow area of 1,120 sq. mm. as opposed to 500 sq. mm. for the outlet pipe, the air-flow passage length is 18 metres long and has forty hairpin bends in it and that is going to cause some constriction to the air flow. Whether or not some constriction is desirable is not at all clear.

Placing the baffles across the width, and still using 3 mm thick baffles, gives an air-passage width of 7.5 mm and a passageway area of 2,100 sq. mm. which is a substantial increase over the original 1,120 sq. mm. It reduces the flow path to 11 metres and that may not be desirable. If you decide to construct one of these devices, then the choice of baffle direction is yours. When securing the layers of aluminium foil and newspaper around the whole surface of the box (except for the air intake hole and the air outlet pipe) Mr Cater suggests using spots of ordinary glue and then wrapping the outside in masking tape.

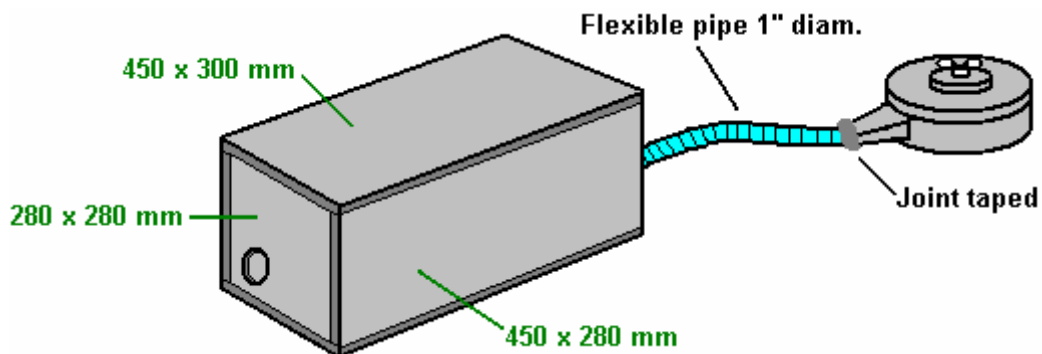

In order to show how the box pieces fit together, the diagram above does not show the layers of aluminium and newspaper surrounding the box on each of the six sides. The joint between the flexible pipe and the air filter can be sealed with duct tape.

Version 2: Is supposed to be easier to construct and more effective in operation. In this arrangement the box is made in the same way and to the same dimensions, but the baffles are replaced by well-packed fibreglass wool sandwiched between two boards, each of which have been drilled with 300 holes 1/16" (1.5 mm) evenly spaced over the area of the board:

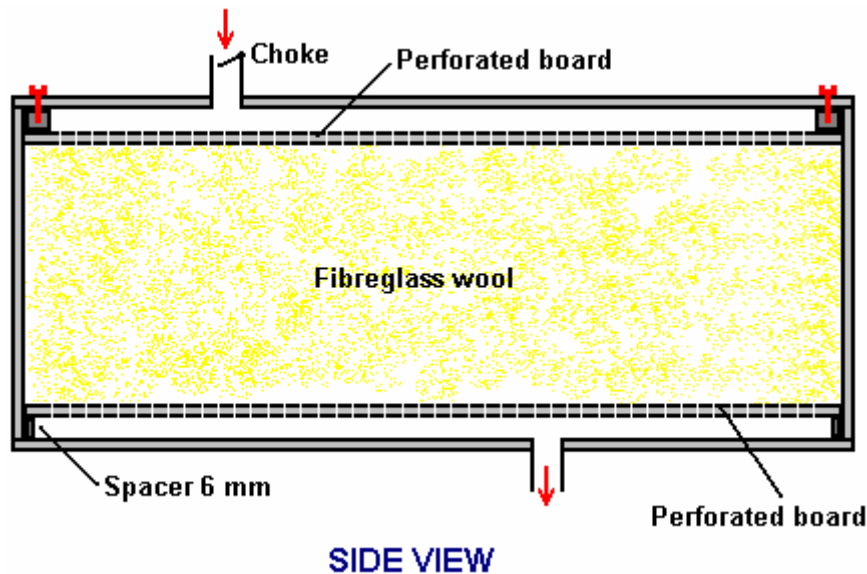

The perforated boards are kept clear of the top and bottom of the box by 6 mm spacers run around the edge of the box and completely sealed along all of their edges. In the diagram above, the 40 layers of aluminium foil and newspaper are not shown. The fibreglass wool is packed tightly around the edges of the box so that the air is forced to flow through it and can't bypass the fibreglass by flowing around the edges of the packing. The main body of the fibreglass wool is arranged to be loose enough for the air to flow through it.

What is shown as a "choke" on the air intake is there to allow the incoming air to be shut off completely in order to deal with a situation where the engine doesn't stop even when the ignition is switched off.

Mr Cater says: "In the above construction, it must be emphasised that the proper packing of the fibreglass wool is of major importance. It must be packed to the extent that the passage of air begins to be seriously restricted. Up to this point, the tighter it is packed the better. The more fibreglass wool, the greater the exposure of the air as it flows through and the greater the dispersion of the air which is a vital factor. If this is not followed, failure will more than likely result. The box should be constructed so that the top can be removed easily." Mr Cater does not say why the top of the box needs to be removable, but presumably it is to allow for the packing density to be altered until the device is working well.

Patrick Kelly

<http://www.free-energy-info.co.uk>

<http://www.free-energy-devices.com>

<http://www.free-energy-info.com>

engpjk@free-energy-info.co.uk

engpjk@gmail.com

Chapter 10: Automotive Systems

There are two or three main objectives for people who create automotive devices – increasing the mpg performance and reducing the harmful emissions are the top two priorities, while running the vehicle on water alone is the aim of a few people.

The first two objectives are readily achievable, but running a vehicle on water alone is not going to happen for almost everybody. This idea is peddled by con artists who sell worthless “plans”, claiming that these will run a vehicle on water for anybody who wants to construct these simple devices. This is just not true. You are welcome to download the "HydroStar" and "HydroGen" plans free from <http://www.free-energy-info.com/P61.pdf> and <http://www.free-energy-info.com/P62.pdf>. However, most experienced people looking at these plans are convinced that they could not possibly produce enough hydrogen/oxygen gas mix to run an engine. While I have never heard of anyone, anywhere, ever getting an engine to run on these plans, the present day science of water is so inadequate, that I am not in a position to be certain that they could not work, and so I am just highly doubtful as to them being viable devices.

Just before getting on to explain the construction details of practical systems, let me put the running of an engine on water alone in its proper context. The internal combustion engine which you own has an efficiency less than 50%. This means that at least half of the energy available from the fuel which you use is wasted and does not produce any useful mechanical output power. In many cases, that percentage can be as high as 90% wasted, but let's be generous and assume that your particular engine is especially good and manages 50% efficiency.

The main way of running an engine with water as the only fuel, involves splitting water into hydrogen and oxygen and then burning those gases to power the engine. To be self-sustaining, the splitting of the water has to be done by the electrics of the vehicle and that means that the efficiency of the water splitting has to be more than 200% efficient. That just doesn't happen with simple systems, so please forget the notion of building some device in your garage with a couple of hours work and waving goodbye to filling stations forever – it ain't going to happen.

Just to set the record straight, it **is** possible to appear to run a car on water alone, but the difficulty level is about the same as building a rocket capable of going into orbit, something well beyond the capabilities of most people, including me. This document does tell you how it can be done, but please understand that it calls for exceptional skills, very considerable expenditure and a great deal of patience, so for the time being, please forget about it.

What can be done quite readily and at low cost, is to construct a device which will raise the efficiency of your engine. This is done by feeding a hydrogen/oxygen gas mix (called “hydroxy” gas) into your engine along with the air which is drawn in to make the engine run. A device of this type is called a “booster” as it boosts the fuel burn, extracting a greater percentage of the fuel's available energy. An important side effect of this improvement in the burn quality of the fuel is the fact that unburnt fuel no longer gets pushed out of the exhaust as harmful emissions.

Another effect is that the engine has greater pulling power and runs smoother. Inside your engine, carbon deposits will have built up from previous un-boosted running and these deposits get burnt away when you use a booster and that internal cleaning extends the engine life.

Some people worry about the fact that burning hydroxy gas produces water and they imagine this water causing rusting inside the engine. What they don't realise is that the ordinary fuel used in the engine is a “hydrocarbon” which is a compound of hydrogen and carbon and that fuel actually splits up to form hydrogen which the engine burns. Actually, it is the carbon part of the hydrocarbon fuel which is the problem, producing Carbon Dioxide, Carbon Monoxide, and physical carbon deposits inside the engine. A normal fuel burn produces water anyway, but you don't get rusting inside the engine as the temperature there is so high that any water is in the form of steam or vapour which dry out completely when the engine is switched off. Adding a small amount of hydroxy gas has no adverse effects at all.

This document describes different types of booster. Let me stress that each engine is different and it depends on how inefficient the engine is to begin with, what sort of mpg improvement is likely to be produced by a booster. Just to make sure that you understand what is involved, a booster is a simple container which holds a set of plates submerged in water which probably has an additive to make the water conduct electrical current better. A pipe from the top of the container feeds the gas into the air filter of the vehicle, via one or two simple safety devices. Adding this gas causes a major improvement in the quality of the fuel burn inside the engine and cuts harmful emission to near zero.

As a consequence of this, it is possible to reduce the amount of fossil fuel being sent to the engine, which is **not** something which should be done if hydroxy gas is **not** being added, as the engine is liable to overheat and some

valve damage could occur. It is a completely different matter if hydroxy gas is being added. However, all recent engine designs have an Electronic Control Unit ("ECU") which controls the amount of fuel being sent to the engine. The ECU accepts input signals from an "oxygen sensor" placed in the exhaust stream, and often a second sensor after the catalytic converter to make sure that the catalytic converter has not failed.

Unfortunately, the much improved exhaust caused by the better fuel burn caused by the hydroxy gas, causes the ECU to think that the engine fuel-air mix must be too low, and so it pumps in more fuel in an effort to compensate. Ideally, this can be dealt with by adding a circuit board which adjusts the signal coming from the oxygen sensor so that it is correct for the improved fuel burn. Details of how to do this are in a companion document.

So, to recap, the only practical device which you can build yourself and use to improve automotive performance is a 'booster'. Using a booster improves the efficiency of the fuel burn inside your engine and that results in more power, better torque, smoother running and vastly improved exhaust emissions. If the ECU is not adjusted or its input signal not controlled, the mpg figures may actually get slightly lower due to unwanted excess fuel being pumped into the engine. If a control circuit is used to correct this ECU error, then mpg gains will be produced.

So, what mpg gains can be expected? The worst I have ever heard of was 8% which is very rare. The lowest likely gain is 20%. Typical gains are in the 25% to 35% bracket. Not particularly unusual is 35% to 60%, while gains up to 100% and over have been achieved but they are rare. A realistic expectation would be a 33% gain.

This chapter is divided up into the following sections:

1. Simple DC boosters, using a 12-volt electrical input.
2. Advanced DC boosters using much higher DC voltages.
3. Water-splitters which use pulsed electrical signals to change water into "hydroxy" gas.
4. Running engines without fossil fuels.
5. Other useful devices.

One thing which needs to be understood:

Caution: A booster is not a toy. If you make and use one of these, you do so entirely at your own risk. Neither the designer of the booster, the author of this document or the provider of the internet display are in any way liable should you suffer any loss or damage through your own actions. While it is believed to be entirely safe to make and use a properly built booster, provided that the safety instructions shown in this document are followed, it is stressed that the responsibility for doing this is yours and yours alone.

Simple DC Boosters.

It is important that you understand the basic principles of electrolysis if you are to be successful in building and operating a booster, or alternatively, buying and operating a booster. A "DC booster" operates on "Direct Current" which is the sort of electrical power delivered by a car battery.

The method is very simple in basic outline. Two metal plates are placed in water and an electric current is passed between the plates. This causes the water to break down into a mixture of hydrogen gas and oxygen gas (The two components used in the Space Shuttle). The greater the flow of current, the larger the volume of gas which will be produced. The arrangement is like this:

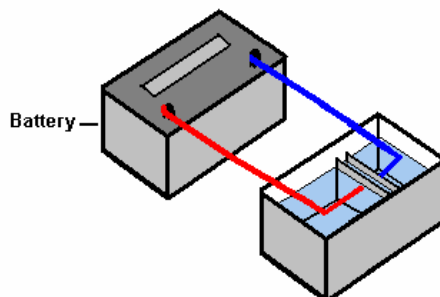

Remembering that the result of doing this is to produce fuel for the Space Shuttle, you should avoid doing this indoors and letting the gas produced by the process collect on the ceiling. There are many videos on the web where people act in a dangerous manner and perform electrolysis indoors using a container which is open at the top as shown above. Please, please don't do that as it is highly dangerous - it is not a party popper which pushes the Space Shuttle into space! If you were to collect a cupful of hydroxy gas and light it, the resulting explosion would probably damage your hearing permanently, so don't do it under any circumstances. Just like the fact that

a very useful chain saw is a dangerous device which needs to be treated with respect, so too, please understand that the very useful hydroxy gas mix contains a lot of energy and so needs to be treated with respect.

This style of electrolysis of water was investigated by the very talented and meticulous experimenter Michael Faraday. He presented his results in a very technical and scientific format which are not understood by most ordinary people. But in simple terms, he tells us that the amount of hydroxy gas produced is proportional to the current flowing through the water, so to increase the rate of gas production, you need to increase the current flow. Also, he found that the optimum voltage between the two "electrode" plates is 1.24 volts.

This sounds a bit technical, but it is a highly useful piece of information. In the arrangement shown above, twelve volts is being connected across two plates in water. Faraday tells us that only 1.24 volts of that twelve volts will go to make hydroxy gas and the remaining 10.76 volts will act as an electric kettle and just heat the water, eventually producing steam. As we want to make hydroxy gas and not steam, this is bad news for us. What it does tell us is that if you choose to do it that way, then only 10% of the power taken by the booster actually makes hydroxy gas and a massive 90% is wasted as heat.

We really don't want a low electrical efficiency like that. One way around the problem is to use two cells like this:

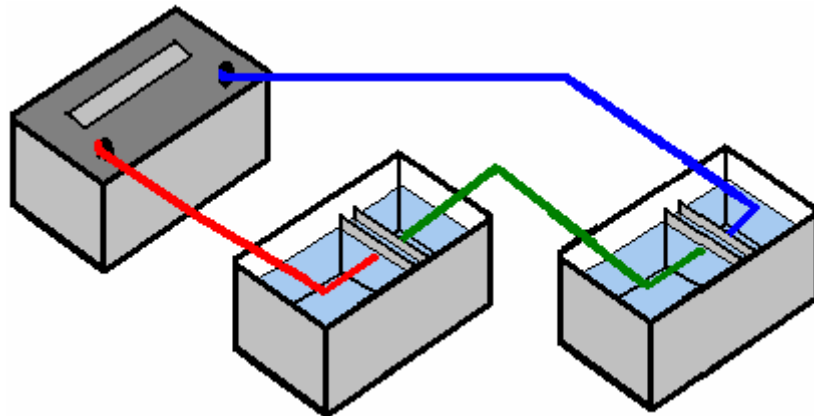

This arrangement uses our 1.24 volts twice while the twelve volts stays unchanged and so the electrical efficiency goes up to 20% and the heat loss drops to 80%. That is quite an improvement but even more important is the fact that twice as much hydroxy gas is now produced, so we have doubled the electrical efficiency **and** doubled the gas output, giving a result which is four times better than before.

We could go one step further and use three cells like this:

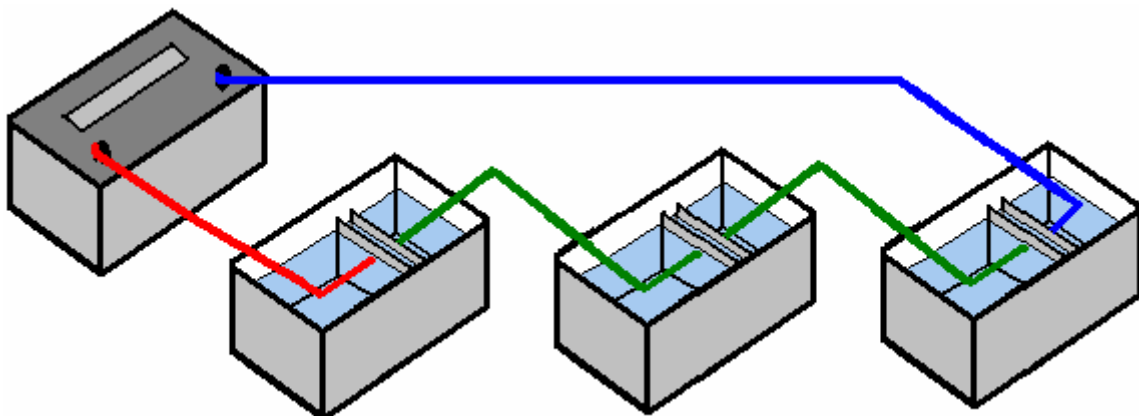

This time we are using three of our 1.24 volt sections and this gives us an electrical efficiency of 30% and three times the amount of gas, making the system nine times more effective.

This is definitely going in the right direction, so how far can we take it when using a twelve volt battery? When we use the construction materials which years of testing has shown to be particularly effective, there is a small voltage drop across the metal plates, which means that the very best voltage for each cell is about 2 volts and so with a twelve volt battery, six cells is about the best combination, and that gives us an electrical efficiency of 62% and six times as much gas, which is 37 times better than using a single cell, and the wasted electrical power drops down from 90% to 38%, which is about as good as we can get.

Of course, it would not be practical to have six boxes each as large as a car battery as we would never manage to fit them into most vehicles. Perhaps we could just put all the plates inside a single box. Unfortunately, if we do that, a good deal of the electric current would flow around the plates and not make much gas at all. A top view of this arrangement is shown here:

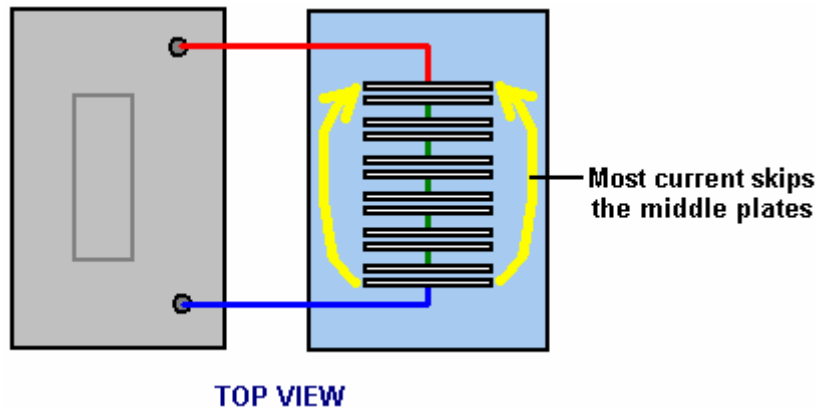

This is a disaster for us as now we will not get your six times the gas production or our massively reduced heating. Thankfully, there is a very simple fix for this problem, and that is to divide the box up into six watertight compartments using thin partitions like this:

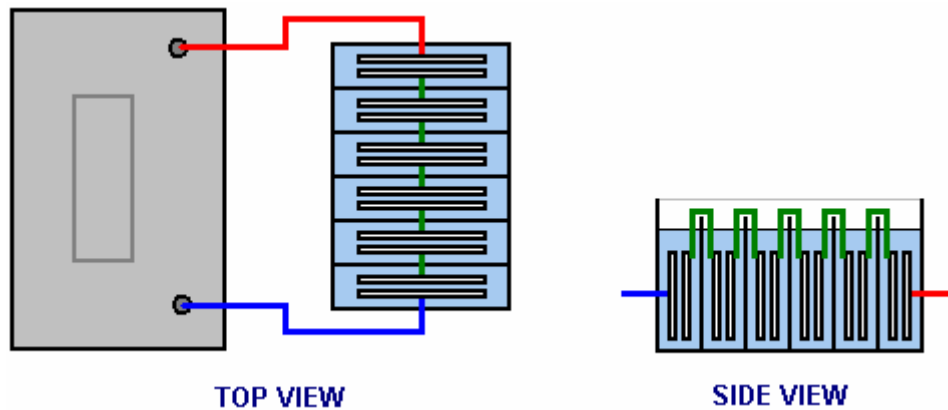

This gives us back our high efficiency by blocking the current flow past the plates and forcing the current to flow through the plates, producing gas between every pair of plates.

In passing, if this booster were to be powered by the electrics of a vehicle, then the voltage although called "twelve volts" will actually be almost fourteen volts when the engine is running so that the "twelve volt" battery will get charged. This would allow us to use seven cells inside our electrolyser, rather than the six cells shown above and that would give us seven times the gas volume that a single pair of plates would give. Some people prefer six cells, and others, seven cells - the choice is up to the person constructing the unit.

We have been discussing the methods of increasing the gas production and reducing the wasted energy, but please don't assume that the objective is to make large volumes of hydroxy gas. It has been found that with many vehicle engines, very good performance gains can be had with a hydroxy gas production rate of less than 1 litre per minute ("lpm"). Flow rates of as little as 0.5 to 0.7 lpm are frequently very effective. Remember, the hydroxy gas from a booster is being used as an igniter for the regular fuel used by the engine and not as an additional fuel.

The big advantage of an efficient booster design is that you can produce the wanted volume of gas using a much lower current, and so, a lesser extra load on the engine. Admittedly, there is not much additional engine load needed by a booster, but we should reduce the extra amount by intelligent design.

In the discussion above, the battery has been shown connected directly across the booster or "electrolyser". This should **never** be done as there is no protection against a short-circuit caused by a loose wire or whatever. There should be a fuse or a circuit-breaker as the first thing connected to the battery. Circuit breakers are available from any electrician's supply outlet as they are used in the "fuse box" in homes, to provide protection for each lighting

circuit and each power socket circuit. They are not expensive as they are manufactured in very large volumes. They are also available on eBay. The circuit breaker is wired like this:

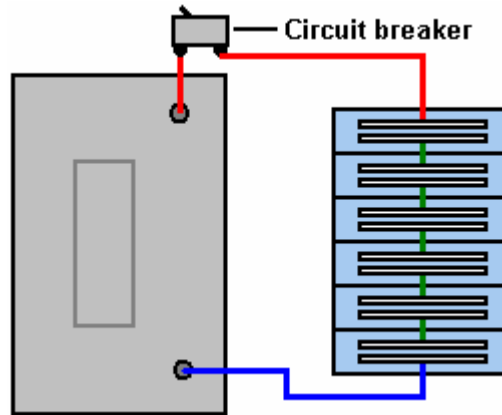

a common design (rated at 32 amps) looks like this:



Some would-be constructors feel that some aspects of the construction are too difficult for them. Here are some suggestions which might make construction more straightforward.

Constructing a seven-cell housing is not difficult. Pieces are cut out for two sides, one base, one lid and six absolutely identical partitions. These partitions must be exactly the same so that there is no tendency for leaks to develop. If you decide to use the bent-plate system of electrodes shown on the next few pages, then drill the bolt holes in the partitions before assembling them:

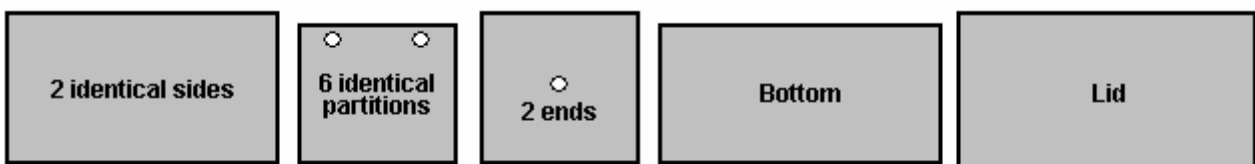

The bottom piece is the same length as the sides, and it is the width of the partitions plus twice the thickness of the material being used to build the housing. If acrylic plastic is being used for the construction, then the supplier can also provide an “adhesive” which effectively “welds” the pieces together making the different pieces appear to have been made from a single piece. The case would be assembled like this:

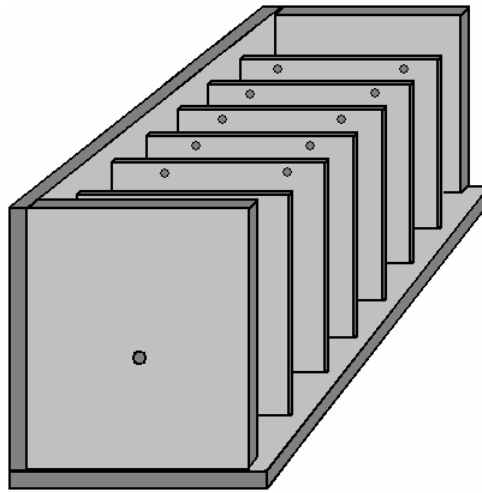

Here, the partitions are fixed in place one at a time, and finally, the second side is attached and will mate exactly as the partitions and ends are all exactly the same width. A simple construction for the lid is to glue and screw a strip all the way around the top of the unit and have the lid overlap the sides as shown here:

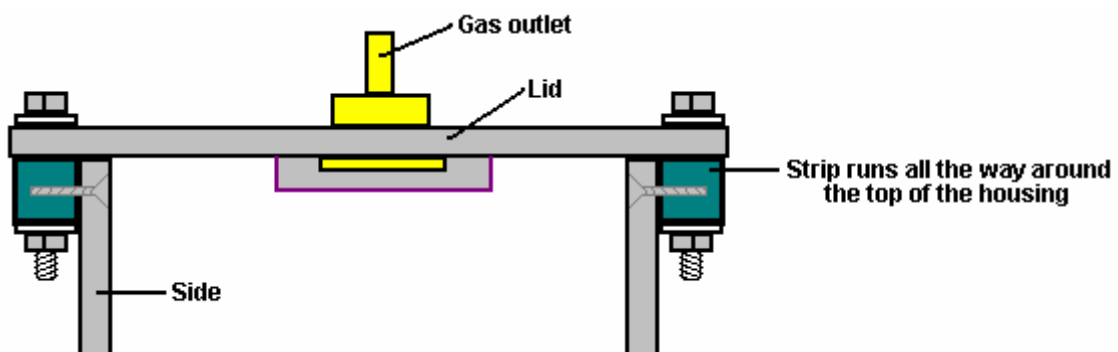

A gasket, perhaps of flexible PVC, placed between the sides and the lid would assist in making a good seal when the lid is bolted down. The gas outlet pipe is located in the centre of the lid which is a position which is not affected if the unit is tilted when the vehicle is on a steep hill.

Years of testing have shown that a really good choice of material for the electrode plates is 316-L grade stainless steel. However, it is very difficult to connect those plates electrically inside the cells as you need to use stainless steel wire to make the connections and bolted connections are really not suitable. That leaves welding the wires to the plates and welding stainless steel is not something which a beginner can do properly as it is much more difficult than welding mild steel. There is a good alternative, and that is to arrange the plate material so that no wire connections are needed:

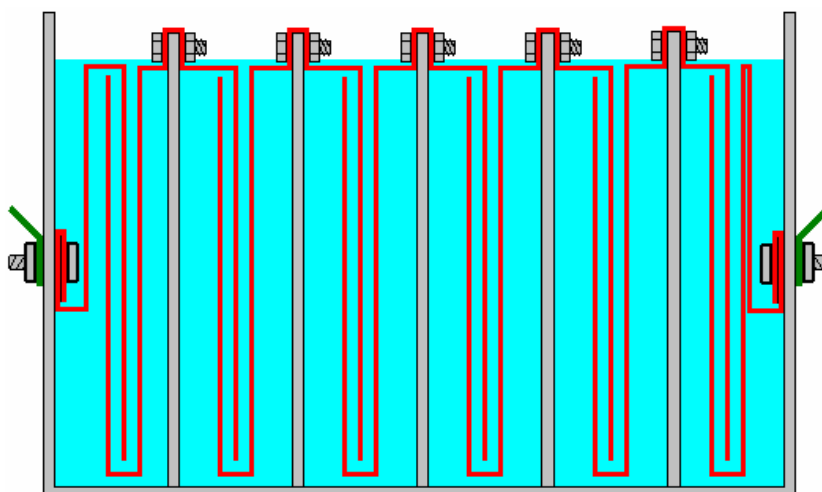

While this six-cell design may look a little complicated to a quick glance, it is really a very simple construction. Each of the plates used in the central cells is just this shape:

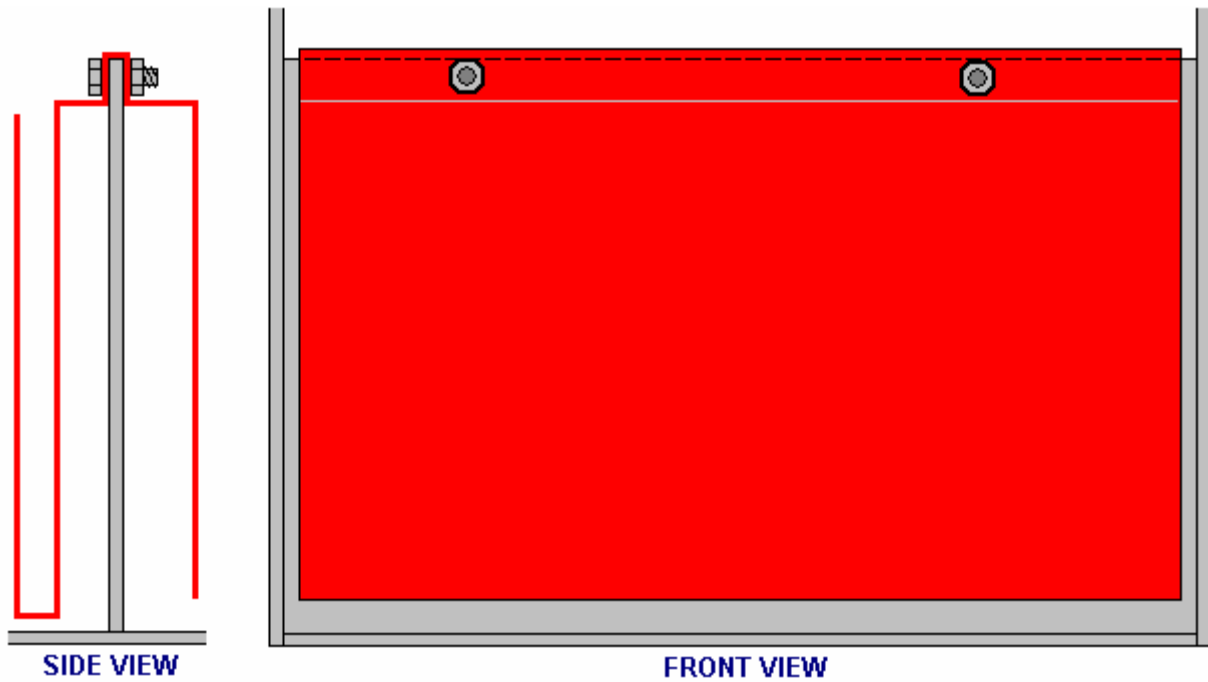

The plate shapes shown above are arranged so that there is access to the bolts from above and they can be reached by a spanner and held steady while the other nut is being tightened.

Unless you are skilled in bending plates, I suggest that you use stainless steel mesh for the plates. It works very well, can be readily cut using tin snips or any similar tool and it can be bent into shape by the home constructor using simple tools - a vice, a piece of angle iron, a small piece of mild steel sheet, a hammer, etc.

You will find a skip outside any metal fabrication shop where scrap pieces are tossed for recycling. There will be off-cuts of various sizes of angle iron and all sorts of other small sections of sheet and strip. They are in the skip mainly to get rid of them as the fabrication business gets paid almost nothing for them. You can use some of these pieces to shape your booster plates, and if you feel bad about costing the business about a penny, then by all means put them back in the skip afterwards.

If you clamp your plate between two angle irons in a vice, then careful, repeated gently tapping with a hammer close to the bend location, will produce a very clean and neat bend in the plate:

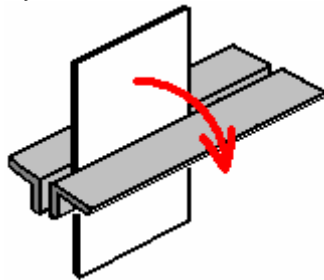

The bent sheet can then be clamped between two steel strips and a sharp U-shaped bend produced by tapping with a hammer, again, along the line of the required bend:

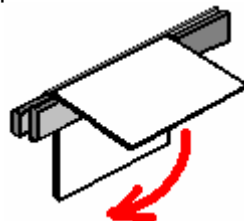

The thickness of the steel bar on the inside of the bend has to be the exact width of the required gap between the finished plate faces. This is not particularly difficult to arrange as 3 mm, 3.5 mm, 4 mm, 5 mm and 6 mm are common thicknesses used in steel fabrication, and they can be combined to give almost any required gap.

There are many varieties of stainless steel mesh. The style and thickness are not at all critical but you need to choose a type which is reasonably stiff and which will hold its shape well after it is bent. This style might be a good choice:

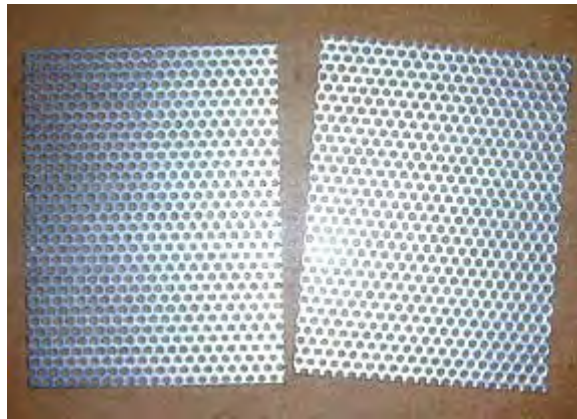

Your local steel supplier probably has some types on hand and can let you see how flexible a particular variety is. The shape shown above is for a "three plate per cell" design where there are two active plate faces. Ideally, you want two to four square inches of plate area per amp of current flowing through the cell, because that gives very long electrode life and minimum heating due to the plates.

This style of construction is reasonably easy to assemble as the two bolts which pass through the partitions and which hold the plates rigidly in place, can be accessed from above, two spanners being used to lock them tight. Lock nuts are optional. If you feel that your particular mesh might be a little too flexible or if you think that the bolts might eventually loosen, then you can attach two, or more, separator insulating pieces - plastic washers, plastic bolts, cable ties or whatever to one of the plate faces.

These will hold the plates apart even if they were to become loose. They also help to maintain the gap between the plates. This gap has to be a compromise because the closer the plates are together, the better the gas production but the more difficult it is for the bubbles to break away from the plates and float to the surface and if they don't do that, then they block off some of the plate area and prevent further gas production from that part of the plate as the electrolyte no longer touches the plate there. A popular choice of gap is 1/8 inch which is 3 mm as that is a good compromise spacing. Circular spacers would look like this:

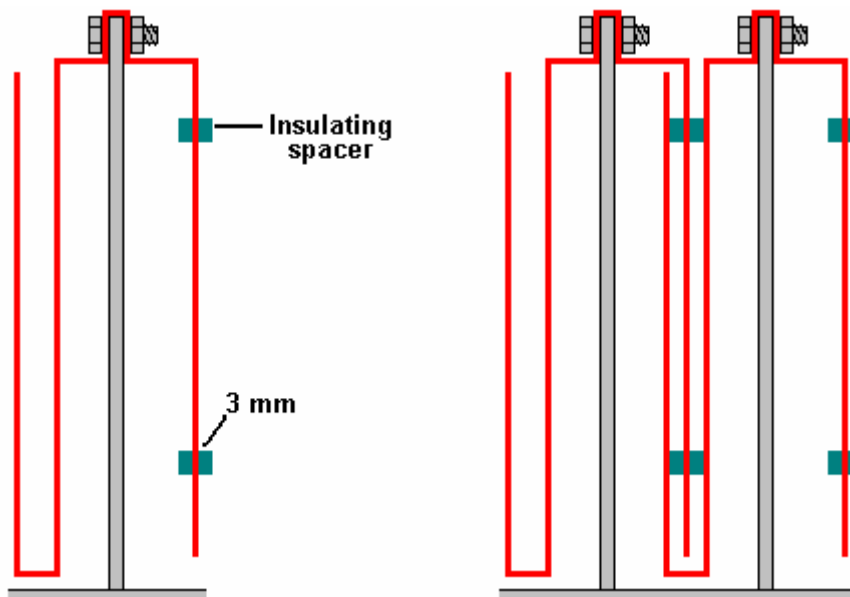

If the current is low enough, an even more simple shape which has just a single pair of active plate surfaces per cell, can be used as shown here:

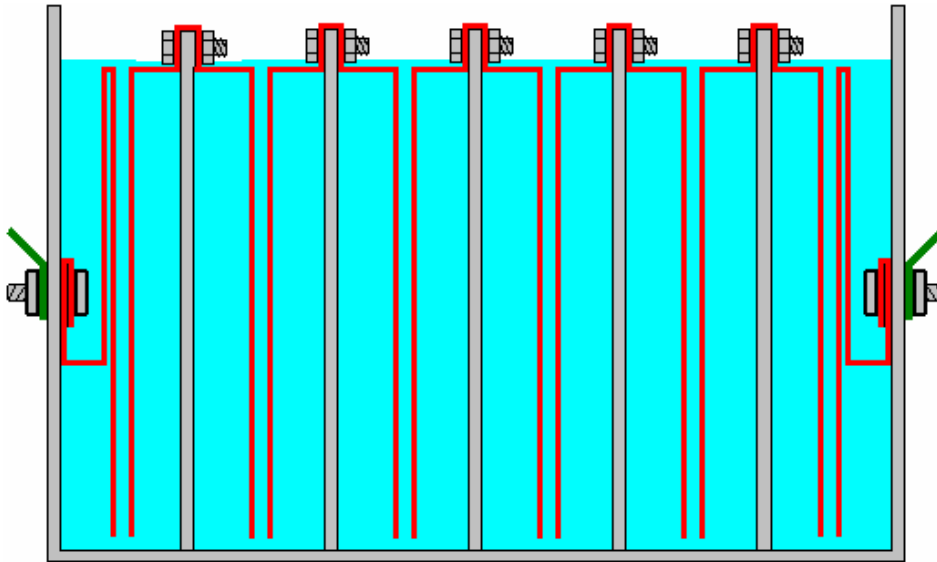

Any of these designs can be 6-cell or 7-cell and the plates can be constructed without outside help. You will notice that the electrical connections at each end of the booster are submerged to make sure that a loose connection can't cause a spark and ignite the hydroxy gas in the top of the housing. There should be a gasket washer on the inside to prevent any leakage of the electrolyte past the clamping bolt.

If you want to use three active plate pairs in each cell, then the plate shape could be like this:

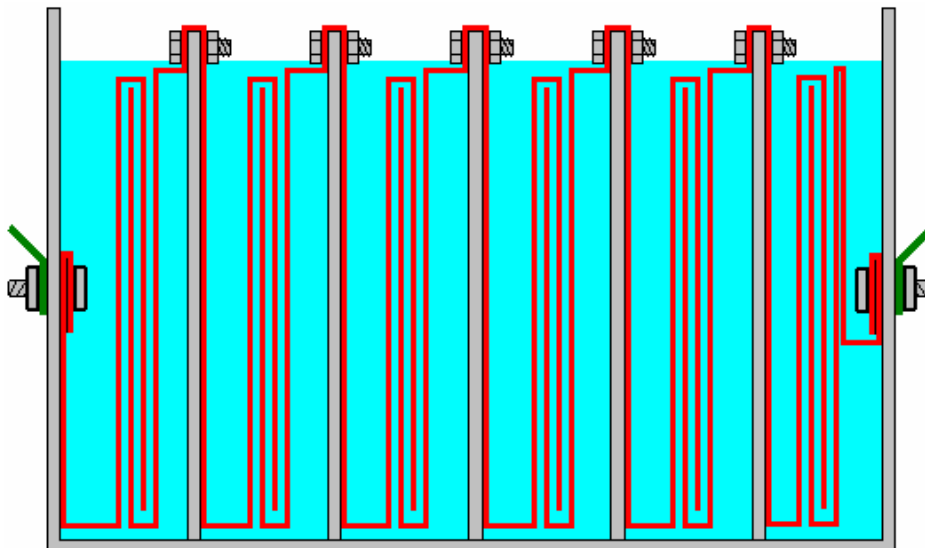

The electrolyte is a mix of water and an additive to allow more current to flow through the liquid. Most of the substances which people think of to use to make an electrolyte are most unsuitable, producing dangerous gasses, damaging the surfaces of the plates and giving uneven electrolysis and currents which are difficult to control. These include salt, battery acid and baking soda and I strongly recommend that you do not use any of these.

What is needed is a substance which does not get used up during electrolysis and which does not damage the plates even after years of use. There are two very suitable substances for this: sodium hydroxide, also called "lye" or "caustic soda". In the USA, this is available in Lowes stores, being sold as "Roebic 'Heavy Duty' Crystal Drain Opener". The chemical formula for it is NaOH.

One other substance which is even better is potassium hydroxide or "caustic potash" (chemical formula KOH) which can be got from soap-making supply shops found on the web. Both NaOH and KOH are very caustic materials and they need to be handled with considerable care.

Bob Boyce of the USA is one of the most experienced people in the construction and use of boosters of different designs. He has kindly shared the following information on how to stay safe when mixing and using these chemicals. He says:

These materials are highly caustic and so they need to be handled carefully and kept away from contact with skin, and even more importantly, eyes. If any splashes come in contact with you, it is very important indeed that the affected area be rinsed off immediately with large amounts of running water and if necessary, the use of vinegar which is acidic and so will neutralise the caustic liquid.

When making up a solution, you add small amounts of the hydroxide to distilled water held in a container. The container must **not** be glass as most glass is not high enough quality to be a suitable material in which to mix the electrolyte. The hydroxide itself should always be stored in a sturdy, air-tight container which is clearly labelled "DANGER! - Potassium (or Sodium) Hydroxide". Keep the container in a safe place, where it can't be reached by children, pets or people who won't take any notice of the label. If your supply of hydroxide is delivered in a strong plastic bag, then once you open the bag, you should transfer all of its contents to sturdy, air-tight, plastic storage containers, which you can open and close without any risk of spilling the contents. Hardware stores sell large plastic buckets with air tight lids that can be used for this purpose.



When working with dry hydroxide flakes or granules, wear safety goggles, rubber gloves, a long sleeved shirt, socks and long trousers. Also, don't wear your favourite clothes when handling hydroxide solution as it is not the best thing to get on clothes. It is also no harm to wear a face mask which covers your mouth and nose. If you are mixing solid hydroxide with water, **always** add the hydroxide to the water, and not the other way round, and use a plastic container for the mixing, preferably one which has twice the capacity of the finished mixture. The mixing should be done in a well-ventilated area which is not draughty as air currents can blow the dry hydroxide around.

When mixing the electrolyte, **never** use warm water. The water should be cool because the chemical reaction between the water and the hydroxide generates a good deal of heat. If possible, place the mixing container in a larger container filled with cold water, as that will help to keep the temperature down, and if your mixture should "boil over" it will contain the spillage. Add only a small amount of hydroxide at a time, stirring continuously, and if you stop stirring for any reason, put the lids back on all containers.

If, in spite of all precautions, you get some hydroxide solution on your skin, wash it off with plenty of cold running water and apply some vinegar to the skin. Vinegar is acidic, and will help balance out the alkalinity of the hydroxide. You can use lemon juice if you don't have vinegar to hand - but it is always a good idea to have a bottle of vinegar handy.

The concentration of the electrolyte is a very important factor. Generally speaking, the more concentrated the electrolyte, the greater the current and the larger the volume of hydroxy gas produced. However, there are three major factors to consider:

1. The resistance to current flow through the metal electrode plates.
 2. The resistance to current flow between the metal plates and the electrolyte.
 3. The resistance to current flow through the electrolyte itself.
1. In a good electrolyser design like those shown above, the design itself is about as good as a DC booster can get, but understanding each of these areas of power loss is important for the best possible performance. We were taught in school that metals conduct electricity, but what was probably not mentioned was the fact that some metals such as stainless steel are quite poor conductors of electricity and that is why electrical cables are made with copper wires and not steel wires. This is how the current flow occurs with our electrolyser plates:

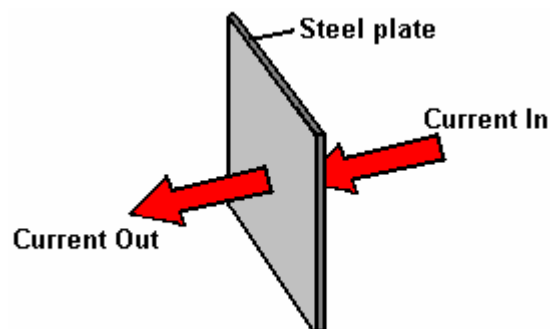

The fact that we have folds and bends in our plates has no significant effect on the current flow. Resistance to current flow through the metal electrode plates is something which can't be overcome easily and economically,

and so has to be accepted as an overhead. Generally speaking, the heating from this source is low and not a matter of major concern, but we provide a large amount of plate area to reduce this component of power loss as much as is practical.

- Resistance to flow between the electrode and the electrolyte is an entirely different matter, and major improvements can be made in this area. After extensive testing, Bob Boyce discovered that a very considerable improvement can be made if a catalytic layer is developed on the active plate surface. Details of how this can be done are given later in the companion "D9.pdf" document as part of the description of Bob's electrolyser.

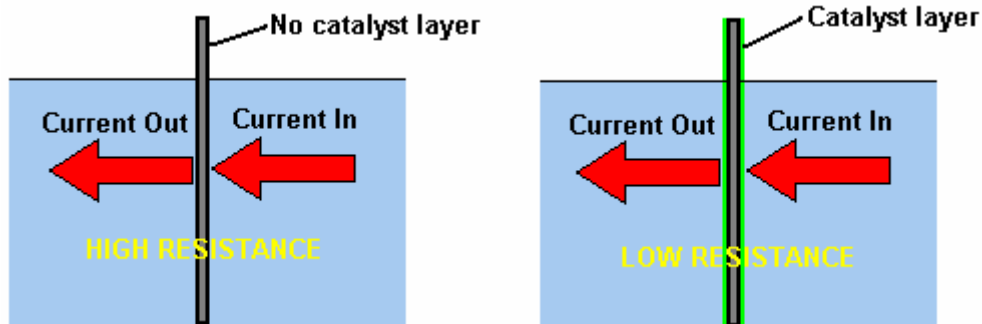

- Resistance to flow through the electrolyte itself can be minimised by using the best catalyst at its optimum concentration. When using sodium hydroxide, the optimum concentration is 20% by weight. As 1 cc of water weighs one gram, one litre of water weighs one kilogram. But, if 20% (200 grams) of this kilogram is to be made up of sodium hydroxide, then the remaining water can only weigh 800 grams and so will be only 800 cc in volume. So, to make up a 20% "by weight" mix of sodium hydroxide and distilled water, the 200 grams of sodium hydroxide are added (very slowly and carefully, as explained above by Bob) to just 800 cc of cool distilled water and the volume of electrolyte produced will be about 800 cc.

When potassium hydroxide is being used, the optimum concentration is 28% by weight and so, 280 grams of potassium hydroxide are added (very slowly and carefully, as explained above by Bob) to just 720 cc of cold distilled water. Both of these electrolytes have a freezing point well below that of water and this can be a very useful feature for people who live in places which have very cold winters.

Another factor which affects current flow through the electrolyte is the distance which the current has to flow through the electrolyte - the greater the distance, the greater the resistance. Reducing the gap between the plates to a minimum improves the efficiency. However, practical factors come into play here as bubbles need sufficient space to escape between the plates, and a good working compromise is a spacing of 3 mm. which is one eighth of an inch.



However, there is a problem with using the optimum concentration of electrolyte and that is the current flow caused by the greatly improved electrolyte is likely to be far more than we want. To deal with this we can use an electronic circuit called a "Pulse-Width Modulator" (or "PWM") circuit. These are often sold as "DC Motor Speed Controllers" and if you buy one, then pick one which can handle 30 amps of current.

A PWM circuit operates in a very simple way. It switches the current to the electrolyser On and Off many times every second. The current is controlled by how long (in any one second) the current is On, compared to how long it is Off. For example, if the On time is twice as long as the Off time (66%), then the average current flow will be much greater than if the On time were only half as long as the Off time(33%).

When using a PWM controller, it is normal to place its control knob on or near the dashboard and to mount a simple low-cost ammeter beside it so that the driver can raise or lower the current flow as is considered necessary. The arrangement is like this:

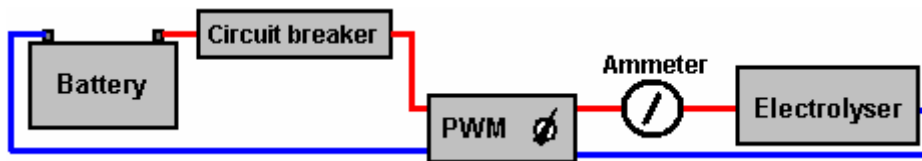

There is a more sophisticated circuit controller called a "Constant-current Circuit" and that allows you to select the current you want and the circuit then holds the current at your set value at all times. However, this type of circuit is not readily available for sale although some outlets are preparing to offer them.

Some of the most simple boosters don't use a PWM circuit because they control the current flow through the booster by making the concentration of the electrolyte very low so that the resistance to current flow through the electrolyte chokes off the current and holds it down to the desired level. This, of course, is far less efficient and the resistance in the electrolyte causes heating, which in turn, is an operational problem which needs careful handling by the user. The advantage is that the system appears to be more simple.

Feeding HHO Gas to an Engine.

When using a booster of any design you need to realise that hydroxy gas is highly explosive. If it wasn't, it would not be able to do it's job of improving the explosions inside your engine. Hydroxy gas needs to be treated with respect and caution. It is important to make sure that it goes into the engine and nowhere else. It is also important that it gets ignited inside the engine and nowhere else.

To make these things happen, a number of common-sense steps need to be taken. Firstly, the booster must not make hydroxy gas when the engine is not running. The best way to arrange this is to switch off the current going to the booster when the engine is not running. It is **not** sufficient to just have a manually-operated On/Off switch as it is almost certain that switching off will be forgotten one day. Instead, the electrical supply to the booster is routed through the ignition switch of the vehicle. That way, when the engine is turned off and the ignition key removed, it is certain that the booster is turned off as well.

So as not to put too much current load on the ignition switch, and to allow for the possibility of the ignition switch being on when the engine is not running, instead of wiring the booster directly to the switch, it is better to wire a standard automotive relay across the oil pressure unit and let the relay carry the booster current. The oil pressure drops when the engine stops running, and so this will also power down the booster.

An extra safety feature is to allow for the (very unlikely) possibility of an electrical short-circuit occurring in the booster or its wiring. This is done by putting a fuse or contact-breaker between the battery and the new circuitry as shown in this diagram:

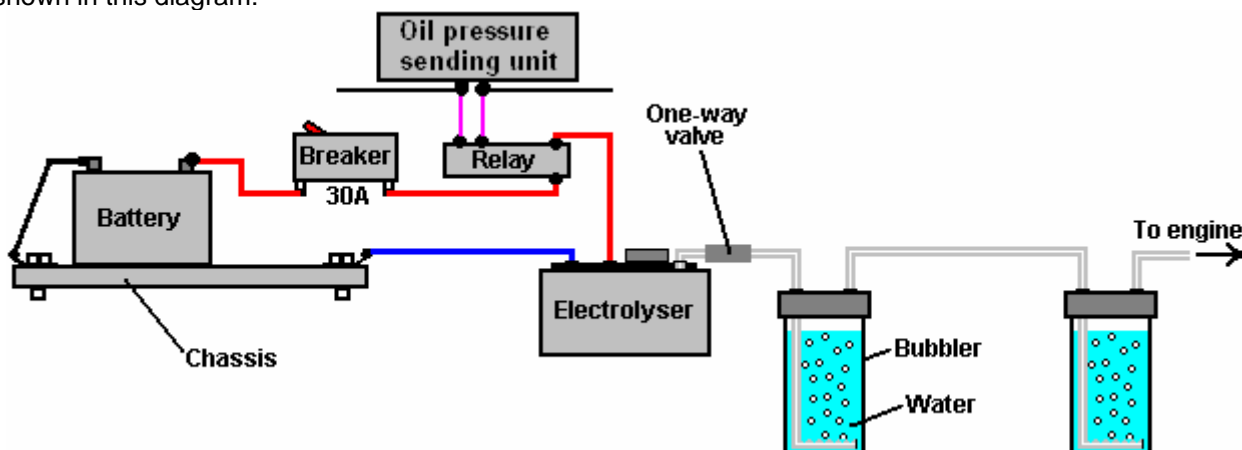

If you choose to use a contact-breaker, then a light-emitting diode ("LED") with a current limiting resistor of say, 680 ohms in series with it, can be wired directly across the contacts of the circuit breaker. The LED can be mounted on the dashboard. As the contacts are normally closed, they short-circuit the LED and so no light shows. If the circuit-breaker is tripped, then the LED will light up to show that the circuit-breaker has operated. The current through the LED is so low that the electrolyser is effectively switched off when the contact breaker opens. This is not a necessary feature, merely an optional extra:



A good source for general components needed in building boosters is The Hydrogen Garage in the USA, website: <http://stores.homestead.com/hydrogengarage/StoreFront.bok> A very important safety item for any booster is the “bubbler” which is just a simple container with some water in it. The bubbler has the gas coming in at the bottom and bubbling up through the water. The gas collects above the water surface and is then drawn into the engine through an outlet pipe above the water surface. To prevent water being drawn into the booster when the booster is off for any length of time and the pressure inside it reduces, a one-way valve is placed in the pipe between the booster and the bubbler.

If the engine happens to backfire, then the bubbler blocks the flame from passing back through the pipe and igniting the gas being produced in the booster. A bubbler is a very simple, very cheap and very sensible thing to install. It also removes any traces of electrolyte fumes from the gas before it is drawn into the engine. In practice, it is a very good idea to have two bubblers, one close to the booster and one close to the engine. The second bubbler makes sure that every last trace of electrolyte fumes are washed out of the hydroxy gas before it enters the engine.

There are various ways to make a good bubbler. In general, you are aimed at having a five-inch (125 mm) depth of water through which the hydroxy gas must pass before it leaves the bubbler. It is recommended that a bubbler is built inside a strong container such as this one:



These strong containers are generally sold as water filters. They can be adapted to become bubblers without any major work being done on them. At this point, we need to consider the mechanism for moving the hydroxy gas out of the booster and into the engine.

It is generally a good idea to position the gas take-off pipe in the centre of the lid so that if the booster gets tilted due to the vehicle operating on a sloped surface, then the surface level of the liquid remains unchanged underneath the gas pipe. A common mistake is to use a gas pipe which has a small diameter. If you take a length of plastic pipe of a quarter inch diameter (6 mm) and try blowing through it, you will be surprised at how difficult it is to blow through. There is no need to give your booster that problem, so I suggest that you select a gas pipe of half an inch (12 mm) or so. If in doubt as to how suitable a pipe is, then try blowing through a sample length of it. If you can blow through it without the slightest difficulty, then it is good enough for your booster.

One other thing is how to deal with splashes and the spray from bubbles bursting at the surface of the electrolyte. You want some device which will prevent any spray or splashes caused by the vehicle going over a very rough road, from entering the gas pipe and being drawn out of the booster along with the hydroxy gas.

Various methods have been used and it is very much a matter of personal choice as to how you decide to deal with the issue. One method is to use a piece of suitable material across the end of the pipe. This is generally called anti-slosh material because of the job which it does. The material needs to let the gas pass freely through it but prevent any liquid getting through it. Plastic pot-scrubbers as a possible material as they have an interlocking mesh of small flat strands. The gas can flow around and through the many strands, but splashes which go in a straight line will hit the strands and drip back into the booster again. Another possible device is one or more baffles which will catch the liquid but let the gas pass freely by:

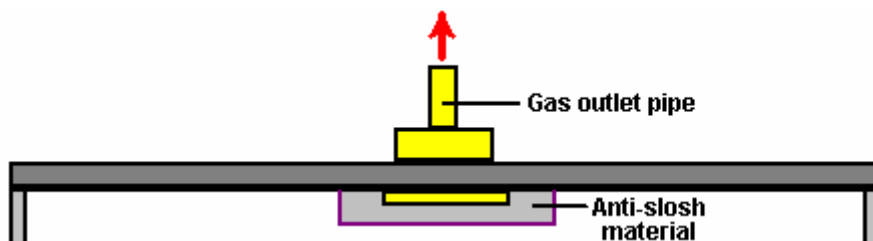

OR

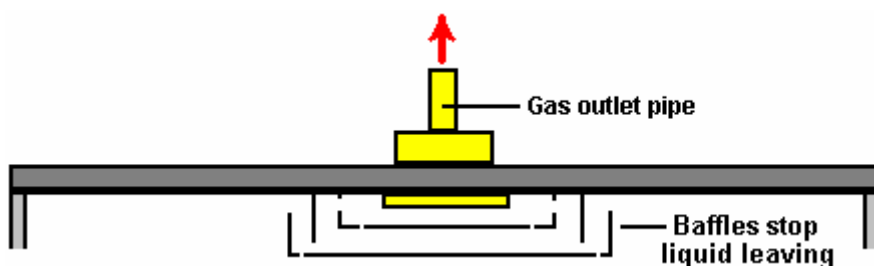

OR

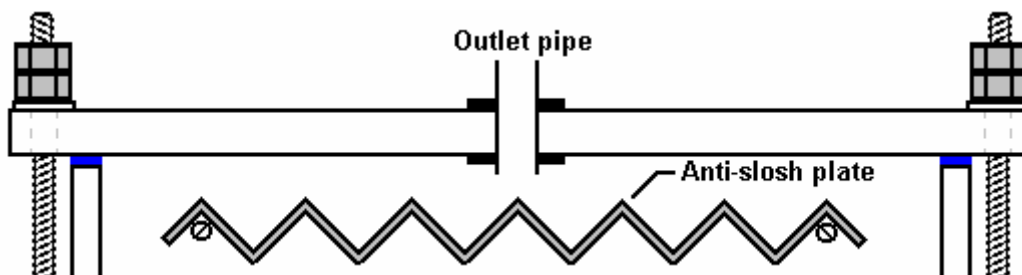

The hydroxy gas produced by a DC booster of this type contains about 30% monatomic hydrogen, which means that 30% of the hydrogen is in the form of single atoms of hydrogen and not combined hydrogen pairs of atoms. The monatomic form is about four times more energetic than the combined form and so it takes up a greater volume inside the booster housing.

If the booster is left turned off for a long period of time, then these single hydrogen atoms will eventually bump into each other and combine to form the less energetic diatomic form of the gas. As this takes up less space inside the booster, the pressure inside the booster drops and this has been known to suck water out of the bubbler back into the booster. We don't want this to happen as it dilutes our carefully measured electrolyte concentration and it can make the bubbler ineffective due to lack of water.

To deal with this, a one-way valve is put between the booster and the bubbler, positioned so that it does not allow flow back into the booster. In very cold climates, a 28% by weight potassium hydroxide electrolyte will not freeze until -40°C , it is more difficult to stop the bubblers freezing. While it is possible to have equipment which unplugs and can be taken indoors overnight, an alternative is to use alcohol or paraffin (kerosene) instead of water and they generally do not freeze and their fumes are not harmful to an engine.

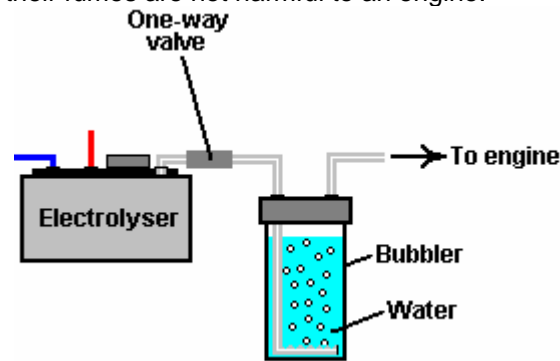

The bubbler design is not difficult. Ideally, you want a very large number of small bubbles to be formed and float upwards through the water. This is because it gives the best connection between the gas and the water and so can do a really good job of washing any traces of hydroxide vapour out of the hydroxy gas before it gets fed to the engine. Small bubbles are also better separated from each other and so there is no real chance of a flame passing through the water where large bubbles might merge together and form a column of gas as they rise to the surface.

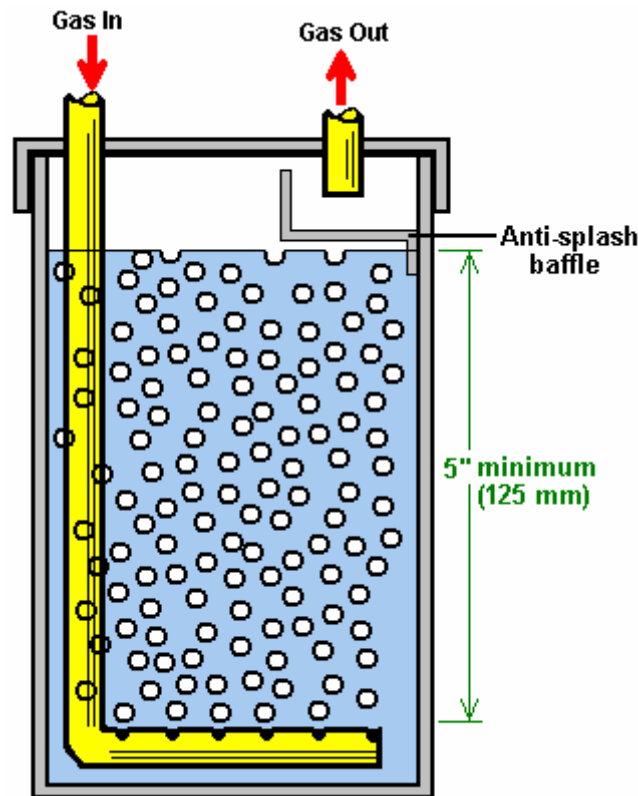

In this good bubbler design, the pipe which feeds the hydroxy gas into the bubbler is bent into an L-shape. The end of the pipe is blocked off, and many small holes are drilled in the horizontal section of the pipe. Only a few holes are seen in this diagram, but there will be a large number in the actual construction. Like the booster itself, the gas outlet pipe needs to be protected from splashes of water caused by the vehicle going over a bump. It is very important to make sure that water is not drawn into the engine along with the gas, so anti-slosh material or one or more baffles are used to prevent this happening. So the overall protection for the gas flow is:



Where the first bubbler is close to the booster and the second one is placed close to the engine. Once in a while, the water from the first bubbler can be used to top up the water inside the booster so that any traces of hydroxide which may have reached the bubbler are returned to the booster, keeping its electrolyte concentration exactly right and making sure that the water in the bubbler is always fresh.

There is one final item which is an optional extra. Some people like to add a gas-pressure switch. If, for any reason, the pressure starts to rise - say that the outlet pipe became blocked - then the pressure switch would disconnect the electrical supply and stop the pressure rising any further:

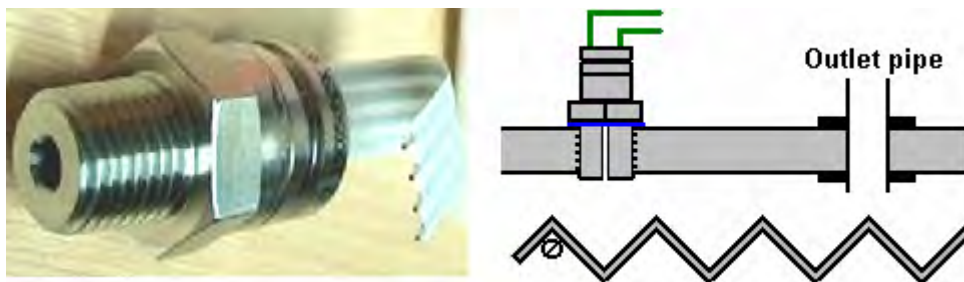

One decision which has to be made is the rate of hydroxy gas production which is the best for you. Most people seem to think that the larger the volume of hydroxy gas the better. That is not necessarily true because a very effective use of the gas is to make it act as an igniter for the engine's normal fuel and very satisfactory results have been achieved with hydroxy gas flow rates in the range of 0.4 to 0.7 litres per minute. You control the rate of gas production by controlling the current, either by the concentration of the electrolyte or by adjusting the current flow using an electronic circuit.

Each litre of water produces about 1,750 litres of hydroxy gas, so you can estimate the length of time the booster can operate on one litre of water. If, for example, your booster is producing 0.7 litres of gas per minute. Then, it will produce 1,750 litres in $1,750 / 0.7$ minutes and that is 2,500 minutes or 41 hours 40 minutes. As the booster only operates when you are driving, you are looking at 41 hours of driving time and if you drive about two hours per day, it would take three weeks to use one litre of water. The internal dimensions of your booster allow you to calculate how far the electrolyte level will drop if one litre of water is taken out of it.

Generally speaking, it is normally considered that topping up the booster with water by hand every so often, is a perfectly good method of operation. The booster design described above has a good electrolyte capacity in each cell and so topping up with water should not be a major task. As tap water and well water have a good deal of dissolved solids in them, when the water is taken away by electrolysis, these solids drop out of solution and fall to the bottom of the housing, and/or coat the plates with an layer of unwanted material. For this reason, life is so much easier if distilled water is used for making electrolyte and for topping up the booster after use.

It is possible to have an automatic water supply for your booster even though that is probably over-kill for such a simple device. If you decide to do that, then you need a water supply nozzle for each of your six or seven cells. It is not necessary for the electrolyte level to be exactly the same in each cell, but you would normally have them at roughly the same height. Your automated water supply could be like this:

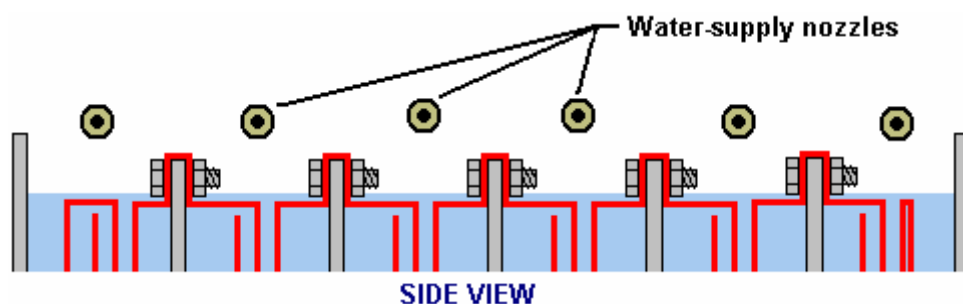

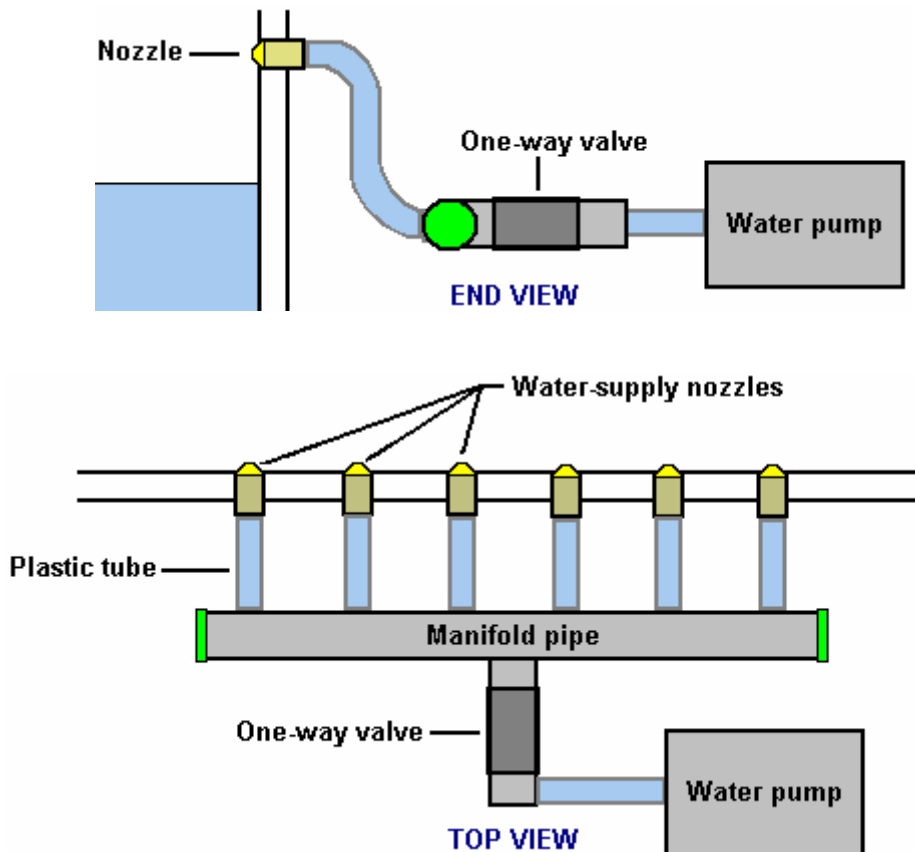

A point which might not be immediately obvious is that because the gas pressure inside the booster is probably about 5 pounds per square inch ("psi"), once the water pump stops pumping, it is possible for the gas pressure to push out the remaining water in the inlet pipes and escape through the body of the pump. To prevent this, an ordinary one-way valve is put in the water supply pipe to prevent flow back towards the pump.

Up to now, the hydroxy gas feed to the engine has just been indicated in a vague way in spite of the connection point being important. With most engines, the hydroxy gas should be fed into the air filter where it mixes well and is fully dispersed inside the air being drawn into the engine. You sometimes see diagrams which show the connection point being close to the engine intake manifold. This is not a good idea because the lowered pressure there causes reduced pressure inside the booster which in turn produces more unwanted hot water vapour, so stick with feeding the gas into the air filter. If there is a supercharger on the engine, then feed the hydroxy gas into the low-pressure side of the supercharger.

The "Smack's" Booster.

The style of booster described above has the advantages of high electrical efficiency, easy construction, very few specialist parts and a large electrolyte volume per cell. There are many other very successful booster designs which have very different forms of construction. One of these is the "Smack's Booster" where electrical cover plates are clamped together and placed inside a length of plastic pipe:



The advantages of this design are the very simple construction, compact size, reasonable performance and the fact that you can buy one ready-made if you want to. You can download a copy of the construction details free from <http://www.free-energy-info.com/Smack.pdf> The electrical efficiency of this design is lowered a bit because only a single body of electrolyte is used and so current can bypass the plates. The overall performance is a respectable 1.3 lpm for 20 amps, though you may wish to lower the current and settle for about half that rate of hydroxy gas production. The construction of a 5 lpm version is at <http://www.youtube.com/watch?v=cqjn3mup1So>

The “Hotsabi” Booster.

Another design which is very easy to build is the "HotSabi" booster, which is a single threaded rod inside a length of plastic pipe with a stainless steel inner lining. It has the lowest possible electrical efficiency, being just a single cell with the full vehicle voltage connected directly across it, but in spite of that, it's performance in actual on the road use has been remarkable, with a reported 50% improvement on a 5 litre capacity engine. This excellent performance is probably due to the design having a steam trap which removes the hot water vapour produced by the excessive heating caused by having only a single cell with so much voltage across it (remember, 90% of the power supplied to this booster design goes in heating the electrolyte).

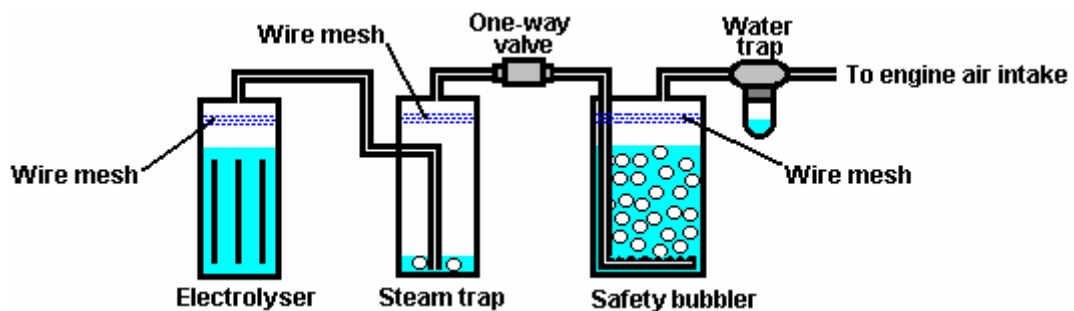

As the designer of this booster has freely shared his design, the free construction plans can be downloaded from <http://www.free-energy-devices.com/Hotsabi.pdf>

The “Zach West” Electrolyser.

Zach West of the USA has produced a motorcycle electrolyser. Zach's 250 cc motorcycle can run on the output of his electrolyser and Zach estimates the output as being 17 litres per minute of HHO gas, which seems to me to be far too high for the current flow. This is not a COP>1 system as the output from the electrical system of the motorcycle is very limited, and so the battery will slowly run down as time goes by. However, Zach's design of electrolyser is interesting, both for it's simplicity and it's high rate of gas output. The increased gas volume which would be produced if this design were adapted for, and driven by, a 12-volt input could be very useful, especially if combined with David Quirey's system which allows the resulting modified gas to operate in unmodified engines, as shown later on in this chapter.

The method which Zach uses is somewhat unusual as he manages to bleed off and discard most of the oxygen produced. This means that the remaining gas is mainly hydrogen which is far less explosive than HHO which is already in the perfect proportions for combination back into water and so is highly reactive. Instead, the resulting gas can be compressed reasonably well, and Zach compresses it to 30 psi (pounds per square inch) in a storage container. This helps with acceleration from stationary at traffic lights.

Zach uses a simple, modular style of construction where a series of coiled electrode pairs are each placed inside an individual length of plastic pipe. This is a design which is neither difficult nor particularly expensive to build. In overall broad outline, Zach's electrolyser is fed water from a water tank to keep it topped up. The electrolyser box contains several pairs of electrodes which split the water into hydrogen and oxygen when fed with pulsed electrical current generated by the electronics, which is powered by the electrical system of the motorcycle. The gas produced by the electrolyser is fed to a dual-purpose bubbler, which prevents any accidental igniting of the gases from travelling back to the electrolyser and in addition, removes most of the oxygen from the gas by acting as a gas "separator". The arrangement is like this:

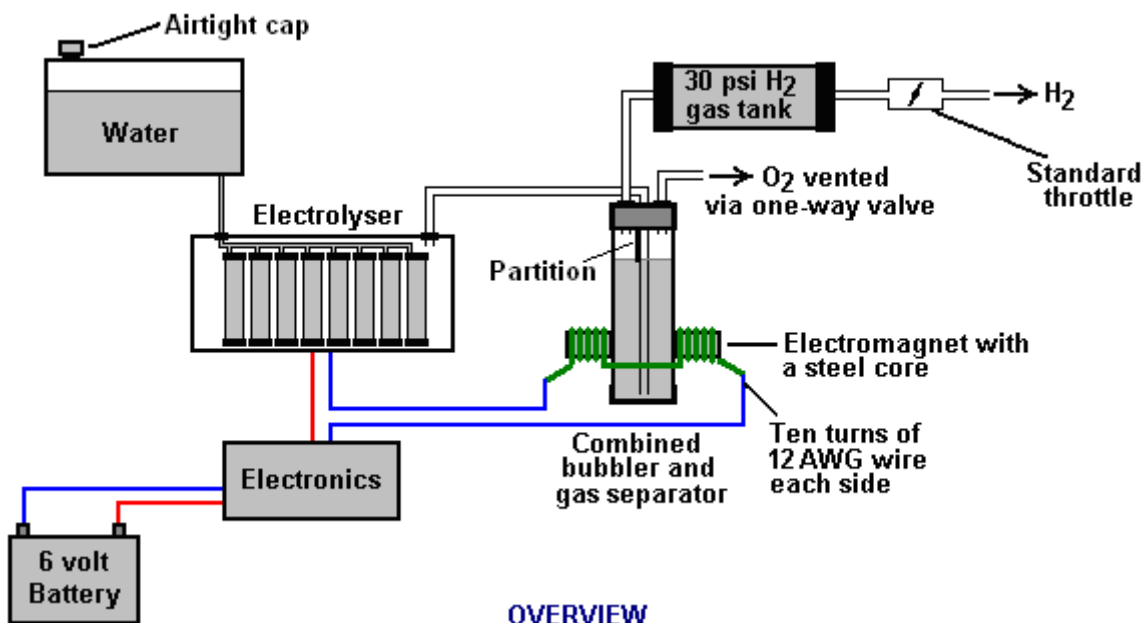

The hydrogen gas output from the electrolyser is not fed directly to the engine but instead it goes to a pressure tank which is allowed to build up to thirty pounds per square inch before the engine is started. The majority of the oxygen produced by the electrolysis is vented away through a 30 psi one-way valve which is included to keep the pressure inside the bubbler (and the electrolyser) at the 30 psi level. That pressure is excessive for a high-performance electrolyser which produces HHO which is highly charged electrically and so will explode spontaneously when compressed, due to its own electrical charge. In this simple DC electrolyser, the HHO gas is mixed with quite an amount of water vapour which dilutes it and allows some compression.

The water supply system operates by having an air-tight supply tank positioned at a higher level than the electrolyser. A small diameter (1/4" or 6 mm) plastic tube coming from the supply tank feeds through the top of the electrolyser and straight down, terminating at exactly the electrolyte surface level wanted in each of the electrolyser tubes. When the electrolysis lowers the electrolyte level below the bottom of the pipe, bubbles of gas pass up the tube allowing some water to flow from the tank to raise the electrolyte surface level back to its design position. This is a very neat passive system needing no moving parts, electrical supply or electronics but yet one which accurately controls the electrolyte level. One essential point to understand is that the water tank needs to be rigid so that it will not flex and the filler cap needs to be air-tight to prevent the entire water supply discharging into the electrolyser. Another point to remember when topping up the water tank is that the tank contains a mix of air and HHO gas above the water surface and not just plain air, and that gas mix is at 30 psi pressure.

Now, to cover the design in more detail. This 6-volt electrolyser contains eight pairs of electrodes. These electrode pairs are coiled around in "Swiss-roll" style and inserted into a length of 2 inch (50 mm) diameter plastic pipe, ten inches (250 mm) tall. The electrodes are each made from a 10 inch (250 mm) by 5 inch (125 mm) of 316L-grade stainless steel shimstock which is easy to cut and work. Shimstock is available from a local steel supplier or metal fabrication company and is just a sheet of very thin metal.

Each electrode is cleaned carefully, and wearing rubber gloves, cross-scored using coarse sandpaper in order to produce a very large number of microscopic mountain peaks on the surface of the metal. This increases the surface area and provides a surface which makes it easier for gas bubbles to break away and rise to the surface. The electrodes are rinsed off with clean water and then coiled round, using spacers to maintain the necessary inter-plate gap, to form the required shape which is then inserted into a length of plastic pipe as shown here:

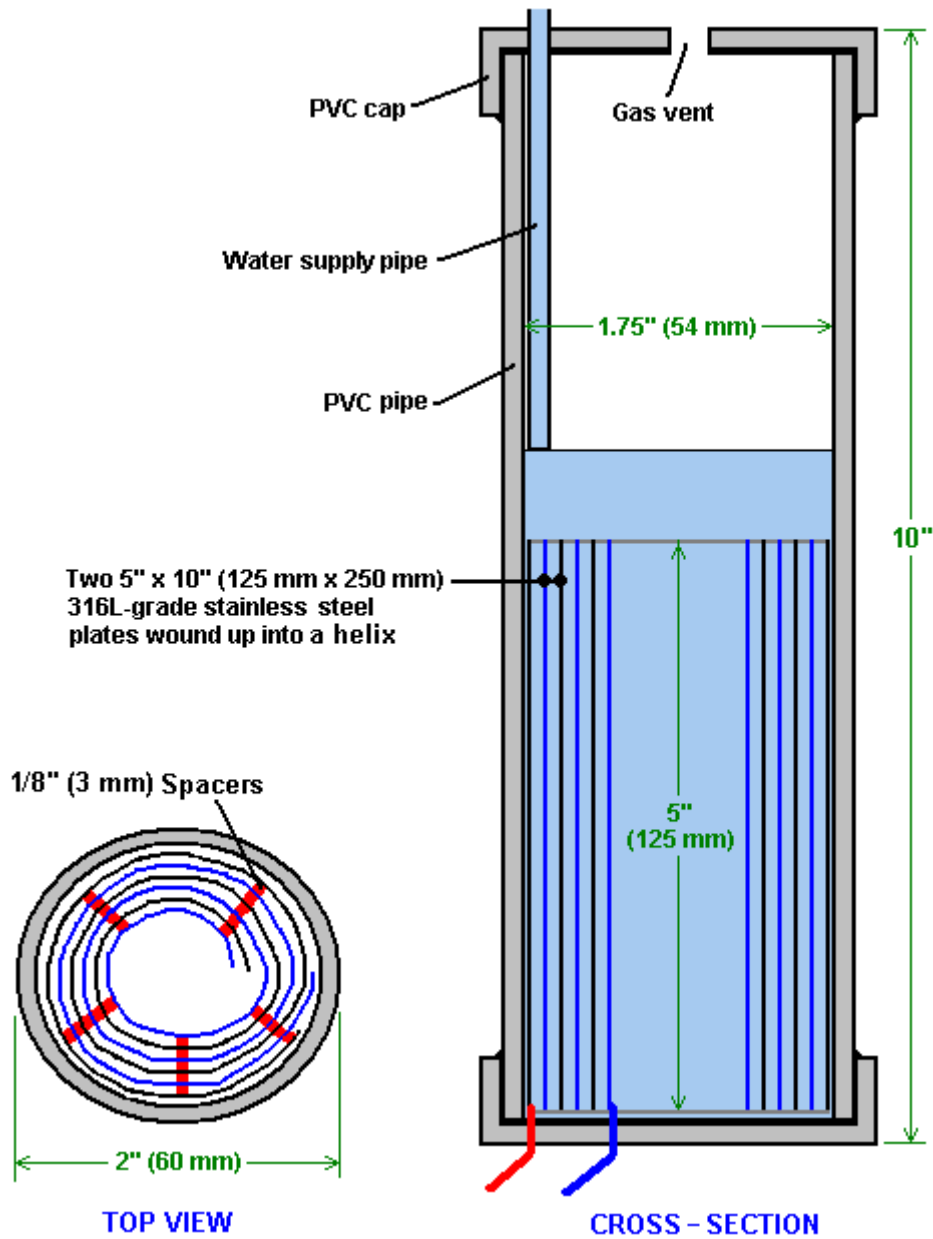

As the springy metal pushes outwards in an attempt to straighten up again, spacers are used to keep the electrodes evenly separated along their whole length by inserting 1/8" thick vertical spacer strips. The connections to the plates are made by drilling a hole in the corner of the plate and inserting the wire several times through the hole, twisting it back around itself and making a wire-to-wire solder joint on both sides of the steel. The joint is then insulated with silicone or any other suitable material. It is, of course, essential that the joint does not short-circuit to the other electrode even though that electrode is very close by.

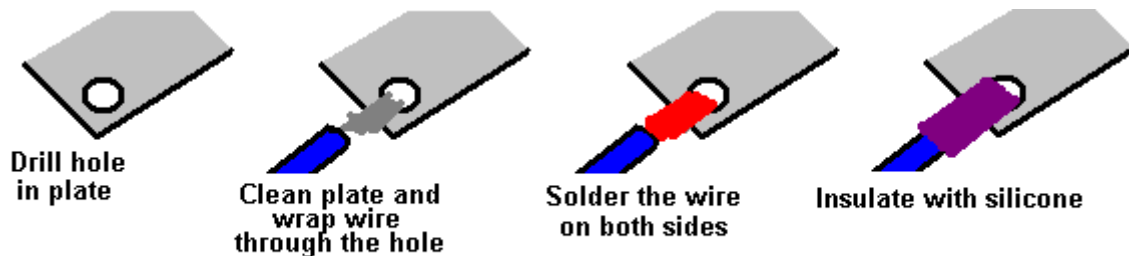

CONNECTING TO THE PLATES

It is always difficult to make a good electrical connection to stainless steel plates if space is restricted as it is here. In this instance, the electrical wire is wrapped tightly through a drilled hole and then soldered and insulated. The soldering is only on the wire as solder will not attach to stainless steel.

An unusual feature of this design is that each of the electrode pairs is effectively a separate electrolyser in its own right as it is capped top and bottom, and effectively physically isolated from the other electrodes. The water feed comes through the top cap which has a hole drilled in it to allow the gas to escape. The electrical wires (#12 AWG or swg 14) are fed through the base and sealed against leakage of electrolyte. Each of these units has some electrolyte stored above it, so there is no chance of any part of the electrode surface not being able to generate gas. There is also a large amount of freeboard to contain splashes and sloshing without any being able to escape from the container. The end caps are standard PVC caps available from the supplier of the PVC piping, as is the PVC glue used to seal them to the pipe.

Eight of these electrodes are placed in a simple electrolyser case and connected together in pairs as shown here:

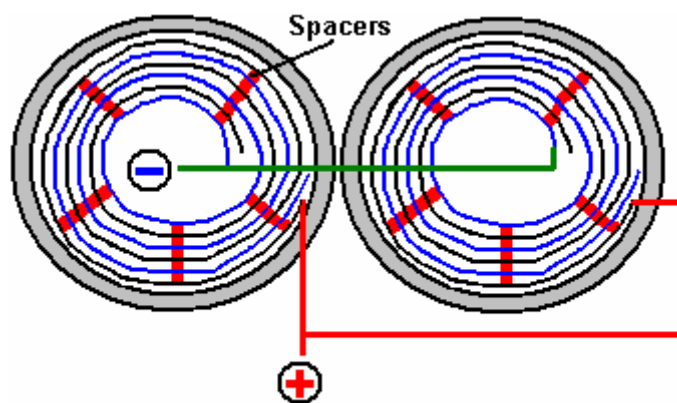

CELLS ARE WIRED IN PAIRS (Top View)

Pairs of pipe-enclosed electrode spirals are then connected in a chain inside the electrolyser as shown here:

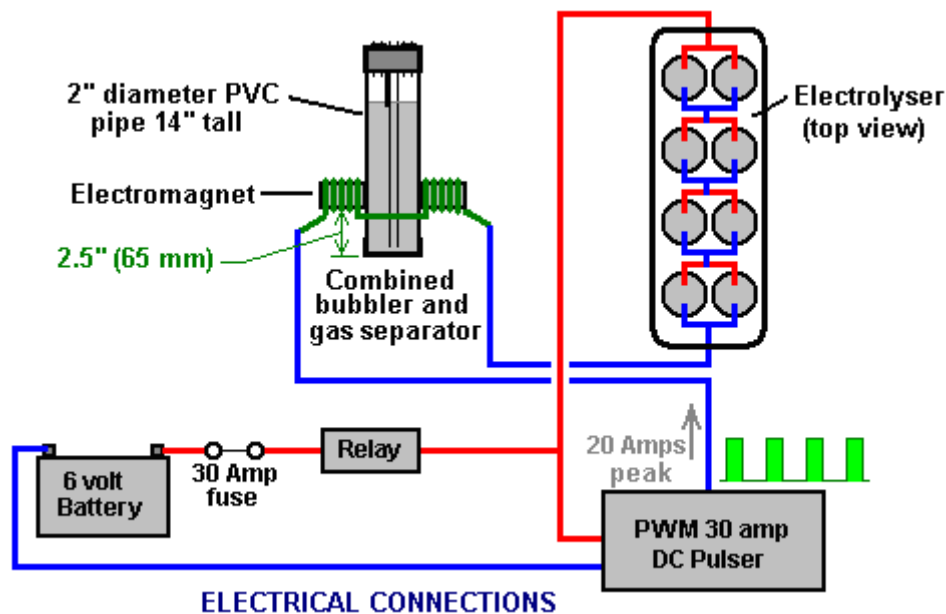

Many years of experimentation and testing have shown that 316L-grade stainless steel is the most suitable material for electrodes, but surprisingly, stainless steel is not highly electrically conductive as you would expect. Each electrode causes a voltage drop of nearly half a volt, and so careful surface preparation, cleansing and conditioning are needed to get top performance from the electrodes. This process is described in detail by the very experienced Bob Boyce who says:

The preparation of the plates is one of the most important steps in producing an electrolyser which works well. This is a long task, but it is vital that it is not skimped or hurried in any way. Surprisingly, brand new shiny stainless steel is not particularly suitable for use in an electrolyser and it needs to receive careful treatment and preparation before it will produce the expected level of gas output.

The first step is to treat both surfaces of every plate to encourage gas bubbles to break away from the surface of the plate. This could be done by grit blasting, but if that method is chosen, great care must be taken that the grit used does not contaminate the plates. Stainless steel is not cheap and if you get grit blasting wrong, then the plates will be useless as far as electrolysis is concerned. A safe method is to score the plate surface with coarse sandpaper. This is done in two different directions to produce a cross-hatch pattern. This produces microscopic sharp peaks and valleys on the surface of the plate and those sharp points and ridges are ideal for helping bubbles to form and break free of the plate.

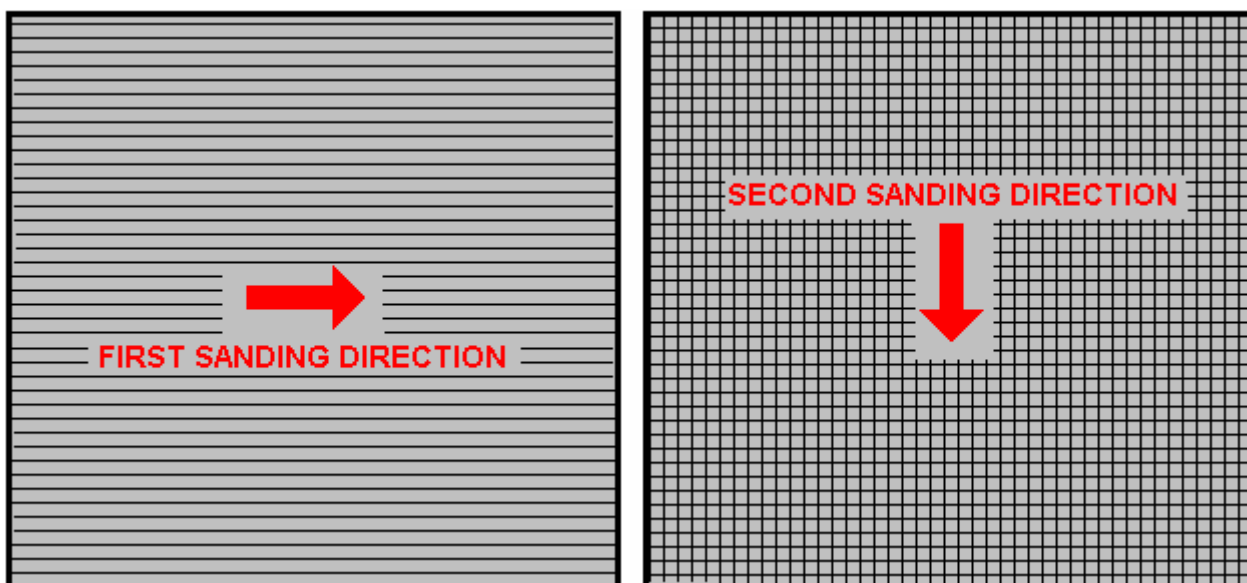

When doing hand sanding the sandpaper is drawn across the plates in **one** direction only and not backwards and forwards, as the backwards stroke always destroys the perfectly good ridges created on the forward stroke. Also,

you only need two strokes in one direction before turning the plate through ninety degrees and completing the sanding of that face of the plate with just two more strokes (again, with **no backstroke**).

Always wear rubber gloves when handling the plates to avoid getting finger marks on the plates. Wearing these gloves is very important as the plates must be kept as clean and as grease-free as possible, ready for the next stages of their preparation. Any particles created by the sanding process should now be washed off the plates. This can be done with clean tap water (not city water though, due to all the chlorine and other chemicals added), but only use distilled water for the final rinse.

While Potassium hydroxide (KOH) and Sodium hydroxide (NaOH) are the very best electrolytes, they need to be treated with care. The handling for each is the same:

Always store it in a sturdy air-tight container which is clearly labelled "DANGER! - Potassium Hydroxide". Keep the container in a safe place, where it can't be reached by children, pets or people who won't take any notice of the label. If your supply of KOH is delivered in a strong plastic bag, then once you open the bag, you should transfer all its contents to sturdy, air-tight, plastic storage containers, which you can open and close without risking spilling the contents. Hardware stores sell large plastic buckets with air tight lids that can be used for this purpose.

When working with dry KOH flakes or granules, wear safety goggles, rubber gloves, a long sleeved shirt, socks and long trousers. Also, don't wear your favourite clothes when handling KOH solution as it is not the best thing to get on clothes. It is also no harm to wear a face mask which covers your mouth and nose. If you are mixing solid KOH with water, always add the KOH to the water, and not the other way round, and use a plastic container for the mixing, preferably one which has double the capacity of the finished mixture. The mixing should be done in a well-ventilated area which is not draughty as air currents can blow the dry KOH around.

When mixing the electrolyte, **never** use warm water. The water should be cool because the chemical reaction between the water and the KOH generates a good deal of heat. If possible, place the mixing container in a larger container filled with cold water, as that will help to keep the temperature down, and if your mixture should "boil over" it will contain the spillage. Add only a small amount of KOH at a time, stirring continuously, and if you stop stirring for any reason, put the lids back on all containers.

If, in spite of all precautions, you get some KOH solution on your skin, wash it off with plenty of running cold water and apply some vinegar to the skin. Vinegar is acidic, and will help balance out the alkalinity of the KOH. You can use lemon juice if you don't have vinegar to hand - but it is always recommended to keep a bottle of vinegar handy.

Plate cleansing is **always** done with NaOH. Prepare a 5% to 10% (by weight) NaOH solution and let it cool down. A 5% solution 'by weight' is 50 grams of NaOH in 950 cc of water. A 10% solution 'by weight' is 100 grams of NaOH in 900 cc of water. As mentioned before, never handle the plates with your bare hands, but always use clean rubber gloves.

A voltage is now applied across the whole set of plates by attaching the leads to the outermost two plates. This voltage should be at least 2 volts per cell, but it should not exceed 2.5 volts per cell. Maintain this voltage across the set of plates for several hours at a time. The current is likely to be 4 amps or more. As this process continues, the boiling action will loosen particles from the pores and surfaces of the metal. This process produces HHO gas, so it is very important that the gas is not allowed to collect anywhere indoors (such as on ceilings).

After several hours, disconnect the electrical supply and pour the electrolyte solution into a container. Rinse out the cells thoroughly with distilled water. Filter the dilute NaOH solution through paper towels or coffee filters to remove the particles. Pour the dilute solution back into the cells and repeat this cleaning process. You may have to repeat the electrolysis and rinsing process many times before the plates stop putting out particles into the solution. If you wish, you can use a new NaOH solution each time you cleanse, but please understand that you can go through a lot of solution just in this cleaning stage if you choose to do it that way. When cleansing is finished (typically 3 days of cleansing), do a final rinse with clean distilled water. It is very important that during cleansing, during conditioning and during use, that the polarity of the electrical power is always the same. In other words, don't swap the battery connections over as that destroys all the preparation work and requires the cleansing and conditioning processes to be carried out all over again.

Using the same concentration of solution as in cleansing, fill the cells with dilute solution. Apply about 2 volts per cell and allow the unit to run. Remember that very good ventilation is essential during this process. As water is consumed, the levels will drop. Once the cells stabilise, monitor the current draw. If the current draw is fairly stable, continue with this conditioning phase continuously for two to three days, adding just enough distilled water to replace what is consumed. If the solution changes colour or develops a layer of crud on the surface of the

electrolyte, then the electrodes need more cleansing stages. After two to three days of run time, pour out the dilute KOH solution and rinse out the cells thoroughly with distilled water.

The construction which Zach has used is very sensible, utilising readily available, low-cost PVC piping. The spiral electrodes are inside 2" diameter pipe and Zach says that the bubbler is also 2" diameter PVC pipe. I seriously doubt that a two-inch diameter bubbler could handle a flow as high as 17 lpm which is a substantial amount. Also. You want the bubbles in the bubbler to be small in order that the gas comes into good contact with the water. Consequently, using more than one bubbler where the diagram shows just one, would be sensible.

At this time, Zach only uses one bubbler, but a second one is highly desirable, located between the storage tank and the engine and positioned as close to the engine as possible. This extra bubbler does two things, most importantly, it prevents the gas in the storage tank being ignited by a backfire caused by a valve sticking slightly open and secondly, it removes every last trace of potassium hydroxide fumes from the gas, protecting the life of the engine. This is a big gain for such a simple addition.

The gas storage tank is also made from PVC pipe, this time, 4 inch (100 mm) diameter, 14 inches (350 mm) long with standard end caps fixed in place with PVC glue as shown below. This is a compact and effective arrangement well suited for use on a motorcycle. The majority of this extra equipment can be mounted in bike panniers, which is a neat arrangement.

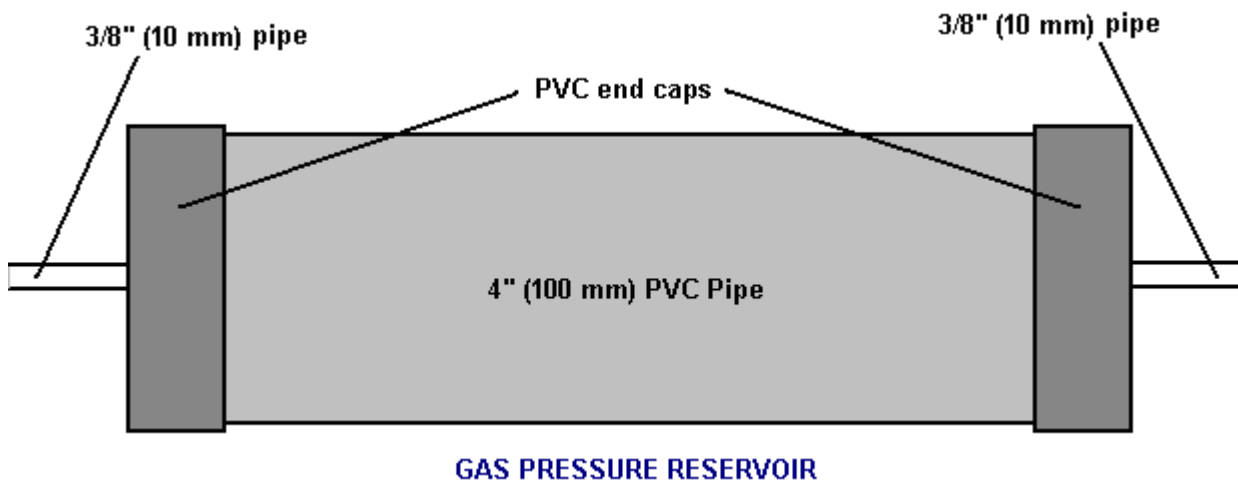

The electric drive to the electrolyser is from a Pulse Width Modulator ("DC Motor speed controller") which was bought from the Hydrogen Garage as Zach is in America. That particular PWM board is no longer available, so especially for those people in Europe the choice might be rmcybernetics.com, although there are many suppliers and the module should not be expensive.



As this unit was rated at just 15 Amps maximum, Zach added another 15 Amp rated FET transistor in parallel to the output stage to raise the current capacity to 30 Amps. A fuse protects against accidental short circuits and a relay is used to control when the electrolyser is to be producing gas. The connecting wire is #12 AWG (swg 14) which has a maximum continuous current capacity of just under ten amps, so although the current peaks may be twenty amps, the average current is much lower than that.

Two electromagnets outside the bubbler, positioned 2.5 inches (65 mm) above the base, are connected as part of the electrical supply to the electrolyser, and these cause most of the oxygen and hydrogen bubbles to separate and exit the bubbler through different pipes. There is a divider across the bubbler to assist in keeping the gases from mixing again above the water surface. The bubbler also washes most of the potassium hydroxide fumes out of the gas as the bubbles rise to the surface, protecting the engine as these fumes have a very destructive effect on engines.

The objective with any hydroxy system is to have the minimum amount of gas between the bubbler and the engine in order to block the ignition of the gas in the unlikely event of a backfire. In this system, the gas storage tank contains a very large amount of gas, though admittedly it is not full HHO gas thanks to the electromagnet separation system, but nevertheless, it would be most advisable to have a second bubbler between the gas storage tank and the engine, positioned as close to the engine as possible. HHO gas produces a very high-speed shock-wave when it is ignited so the bubbler needs to be of strong construction to withstand this. No pop-off bubbler cap or blow-out device acts fast enough to contain a HHO shock-wave, so make the bubbler housing strong enough to withstand the pressure wave.

Zach's electrolyser arrangement is like this:

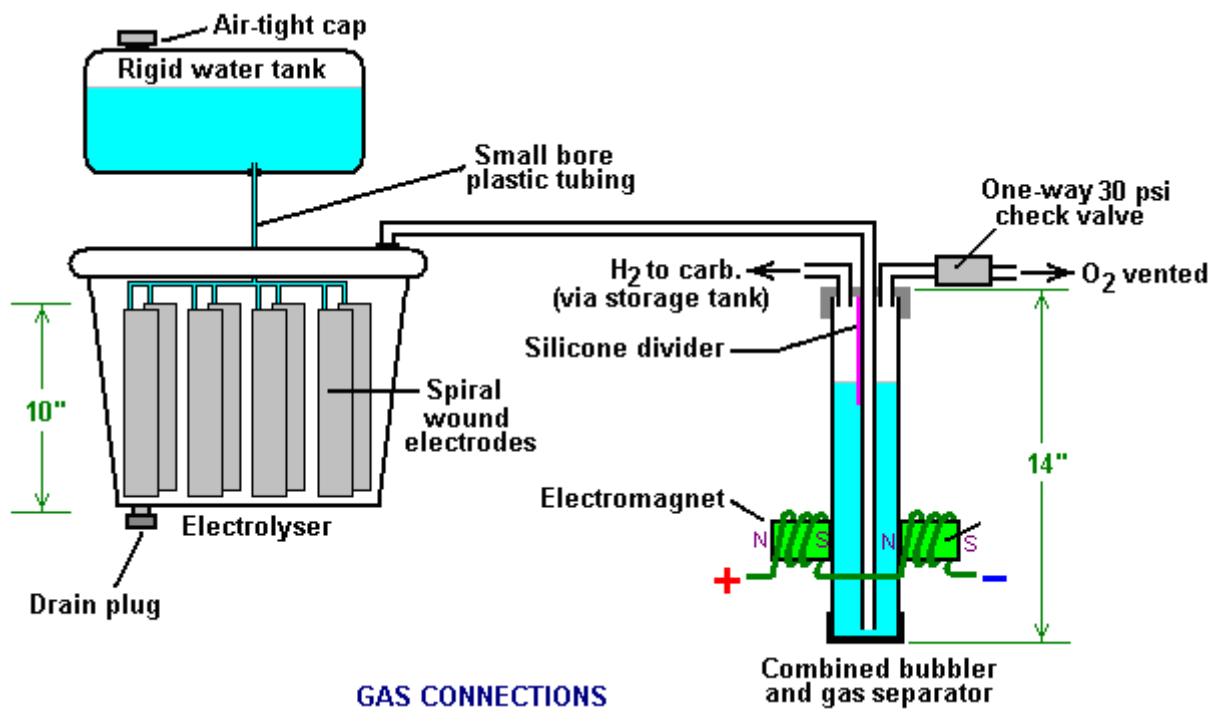

It must be realised that the water tank, electrolyser, bubbler/separator and hydrogen holding tank, all operate at thirty pounds per square inch. This means that each of these containers must be robust enough to withstand that pressure quite easily. It also means that the 30 psi one-way check valve on the oxygen venting pipe is an essential part of the design as well as being a safety feature. As a bubble of gas from the electrolyser escapes into the water tank every time a drop of water feeds to the electrolyser, the contents of the water tank above the water surface becomes a stronger and stronger mix of air and HHO. Consequently, it soon becomes an explosive mixture. It is common for static electricity to build up on a tank of this nature, so it will be very important to earth both the tank and it's cap before removing the cap to top up the tank with more water.

The electrolyser has a potassium hydroxide (KOH) solution in it. The electrolysis process produces a mixture of hydrogen, oxygen, dissolved gases (air) and potassium hydroxide fumes. When the system is being used, the water in the bubbler washes out most of the potassium hydroxide fumes, and in doing so, it gradually becomes a dilute electrolyte itself. Potassium hydroxide is a true catalyst and while it promotes the electrolysis process, it

does not get used up during electrolysis. The only loss is to the bubbler. Standard practice is to pour the contents of the bubbler into the electrolyser from time to time, filling the bubbler again with fresh water. Potassium hydroxide has been found to be the most effective catalyst for electrolysis but it has a very bad effect on the engine if it is allowed to enter it. The first bubbler is very effective in removing the potassium hydroxide fumes, but many people prefer to take the scrubbing process a step further by placing a second bubbler in the line, in this instance, between the hydrogen pressure tank and the engine. With two bubblers, absolutely no potassium hydroxide fumes reach the engine.

When running with HHO gas as the only fuel, it is essential to adjust the timing of the spark so that it occurs after Top Dead Centre. The timing on this bike is now set at 8 degrees after TDC. However, if David Quirey's style of bubbling the HHO through a liquid such as acetone, then no timing alterations would be needed.

This electrolyser is designed to run off the nominal six volts of a motorcycle electrics (about 7.3 volts with the engine running), but increasing the number of tubes, each containing electrode coils, would convert the design to a 12V system and then the electrolyser housing would probably be like this:

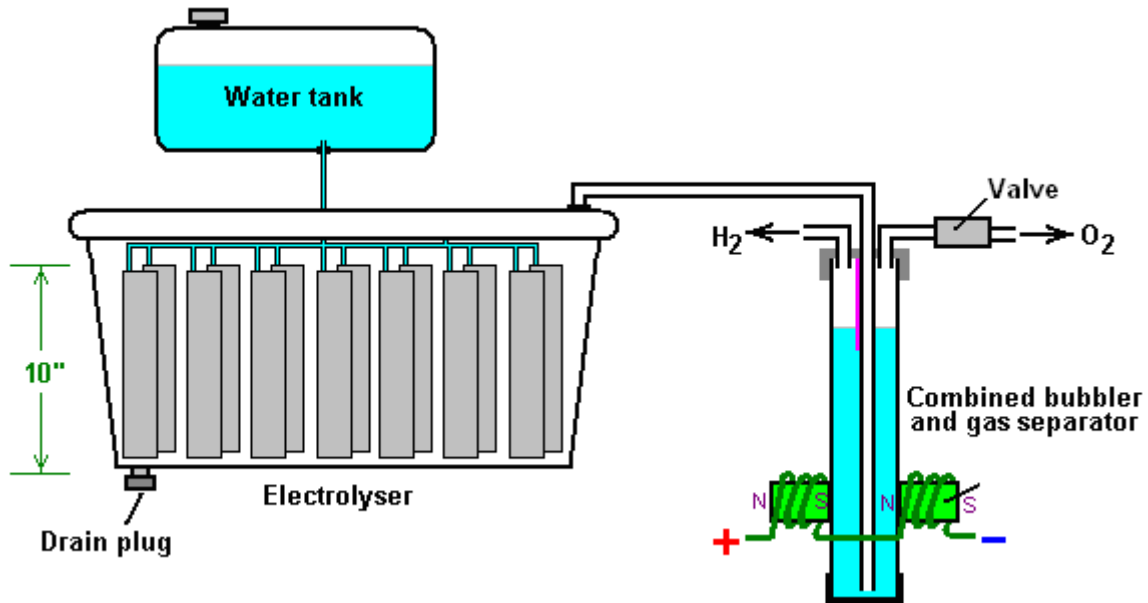

It is possible that seven sets of three or four spirals wired in parallel would be used for larger engines with their 13.8 volt electric systems. Each uses the very simple method of allowing excess gas to be vented via the oxygen valve if gas production exceeds the requirements of the engine. When operating on a twelve volt system it might be more convenient to use a standard pressure switch which opens an electrical connection when the gas pressure rises above the value for that switch:



The pressure switch just mounts on one of the end caps of the pressure tank and the switch electrical connection is placed between the relay and the electrolyser. If the gas pressure reaches it's maximum value of 30 psi. then the switch opens, stopping electrolysis until the pressure drops again:

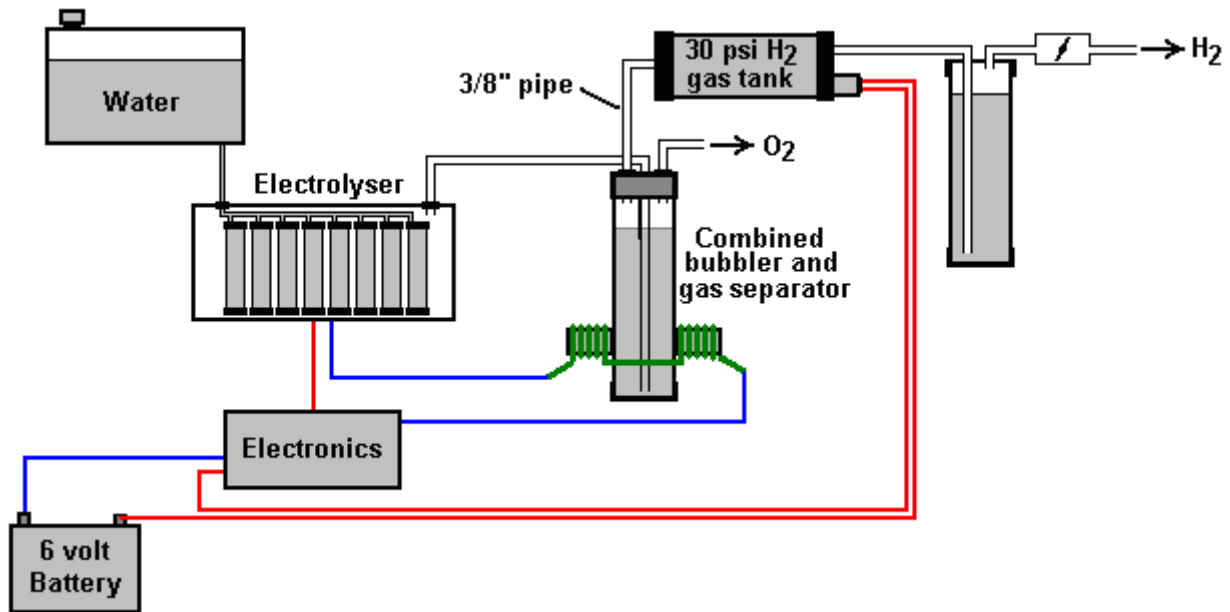

Caution: This electrolyser is not a toy. If you make and use one of these, you do so entirely at your own risk. Neither the designer of the electrolyser, the author of this document or the provider of the internet display are in any way liable should you suffer any loss or damage through your own actions. While it is believed to be entirely safe to make and use an electrolyser of this design, provided that the safety instructions shown below are followed, it is stressed that the responsibility is yours and yours alone.

An electrolyser should not be considered as an isolated device. You need to remember that both electrical and gas safety devices are an essential part of any such installation. The electrical safety devices are a circuit-breaker (as used by any electrician when wiring a house) to protect against accidental short-circuits, and a relay to make sure that the booster does not operate when the engine is not running:

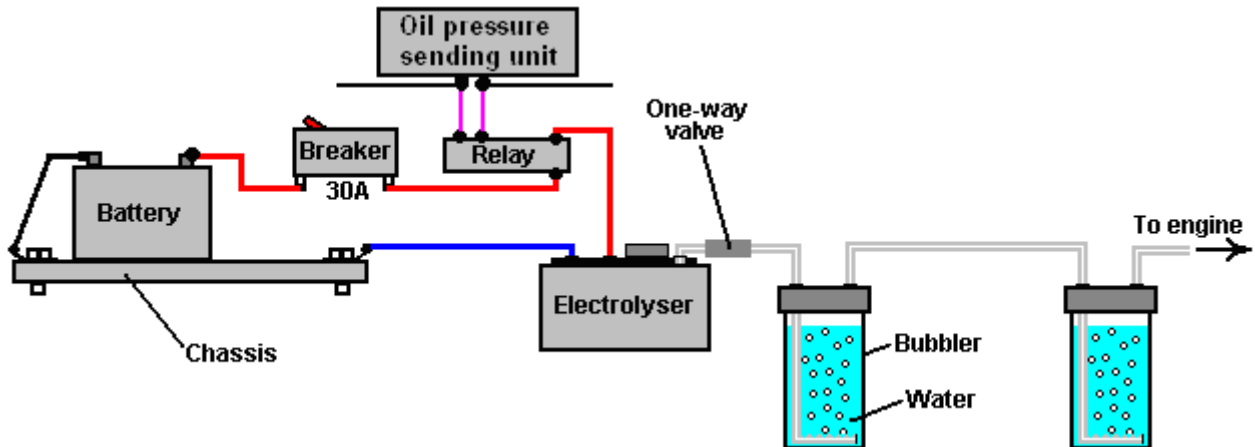

The "DuPlex" Booster designed by Bill Williams.

A fully-submerged design from Bill Williams in the USA is another different style of booster:

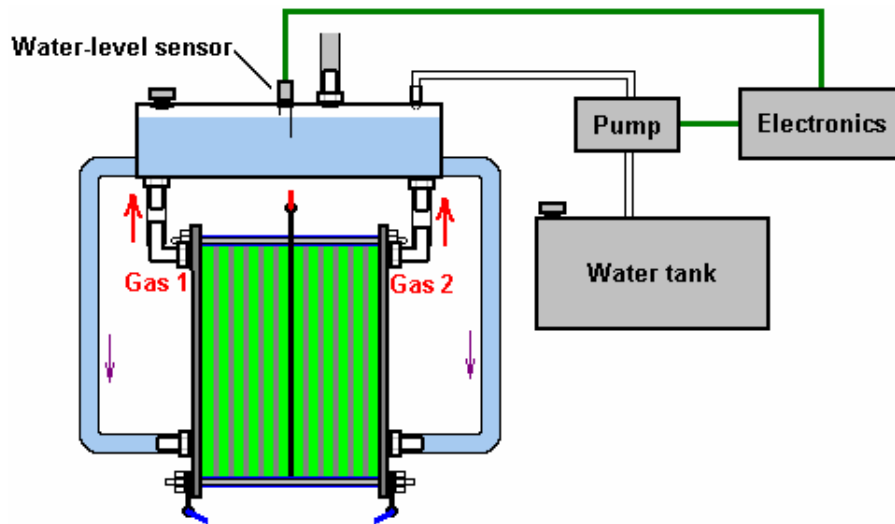

The construction details for this booster design, can be downloaded free from the web using the link: <http://www.free-energy-devices.com/DuPlex.pdf>

There are many other designs, including those with concentric pipes, each having its own advantages and disadvantages, some being commercially available as ready-made devices, and there are links to these boosters on the web sites mentioned above and a general booster forum at <http://tech.groups.yahoo.com/group/watercar/> and another at <http://tech.groups.yahoo.com/group/HHO/> where people will answer any queries.

One problem with the use of boosters is that if the hydroxy gas volume is higher than it needs to be, the vehicle's Electronic Control Unit ("ECU") is liable to detect the improved fuel burn and start pumping in excess fuel to offset the improved conditions. How to deal with this situation is covered in the free document which can be downloaded from <http://www.free-energy-devices.com/D17.pdf>

The "Hogg" Electrolyser from Selwyn Harris.

An interesting design is the Hogg electrolyser as described by Selwyn Harris of Australia. The Hogg cell has two stainless steel mesh electrodes coiled around each other. This gives a large electrode surface area in a very compact container. In this version of the design there are six identical cells which feed into a large bubbler. For clarity, only two of the six electrolyser cells are shown here:

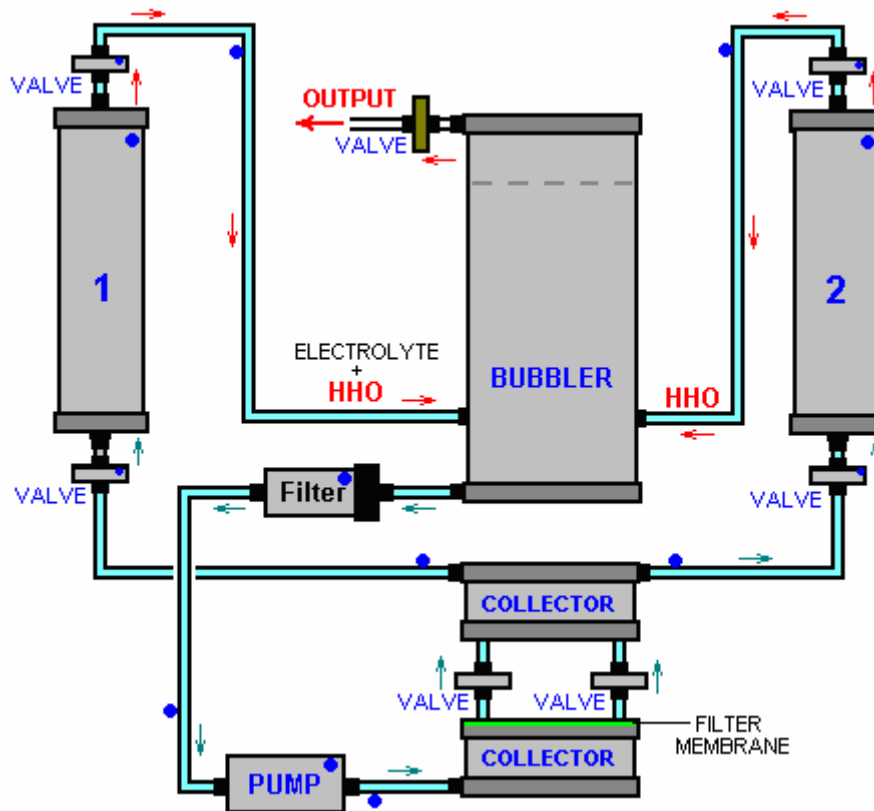

The items marked with a blue dot form just one of three identical sets. That is, three filters feed out from the bottom of the bubbler, the flow through them being caused by three separate pumps and the two electrolyser cells marked "1" and "2" along with their associated pipes and four one-way valves, are replicated to give electrolysis cells "3" to "6" which are not shown in this diagram. Those three identical sets are connected to the central bubbler, spaced around it evenly at 120-degree positions horizontally as shown in rough outline here:

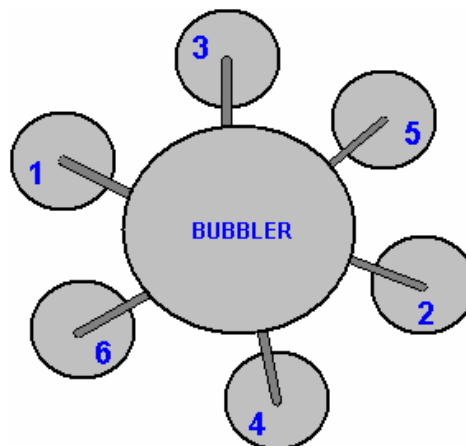

The water is circulated through the set of cells using three small pumps and there are two water collectors built on to the bottom of the bubbler. Also, as the 'electrolyte' used is rainwater, and each electrolysis cell is completely full of electrolyte as this is an 'electrolyte circulation' style of electrolyser.

Each of the three pumps has it's own filter to trap any particles coming from the cells as experience has shown that the water can contain a considerable amount of material. The filters are standard irrigation in-line filters made from transparent plastic filled for three quarters of their length with fine plastic sponge material.

A key feature of the cell design is the use of two powerful neodymium magnets per cell. These act directly on the water and that causes a major increase in the gas production rate. The magnets have their North poles facing towards each other.

The two mesh electrodes are made from stainless steel wire of 0.32 mm diameter and woven to give 2 mm holes between the wires and a 0.65 mm overall sheet thickness. These dimensions are important as other mesh sizes and styles do not give so good a performance. The electrodes are wider at one end to form a connection tab

which allows easy electrical connection to each electrode and they are then wired in parallel so that each cell gets 12 volts across it as shown here:

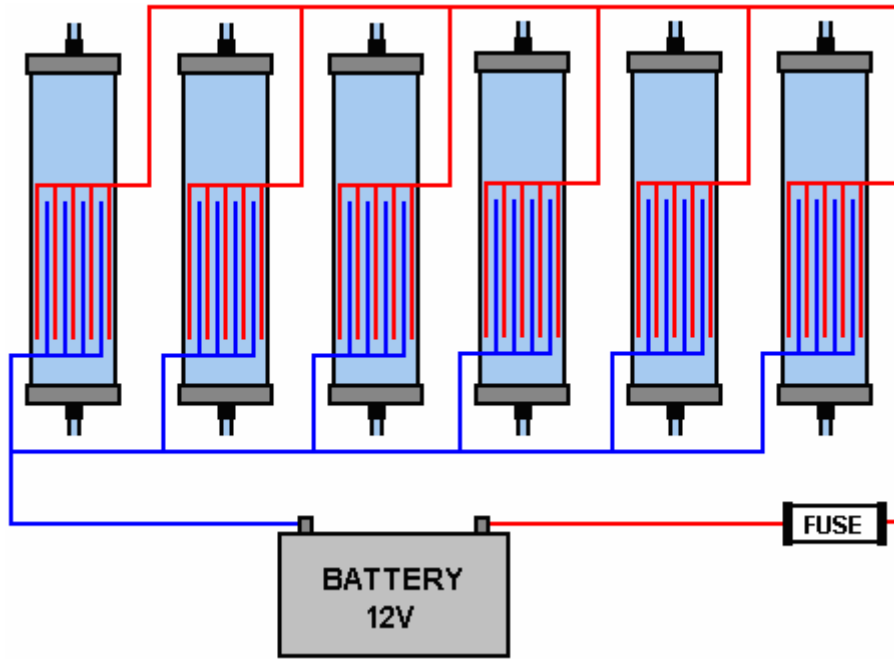

The two mesh electrodes are cut like this:

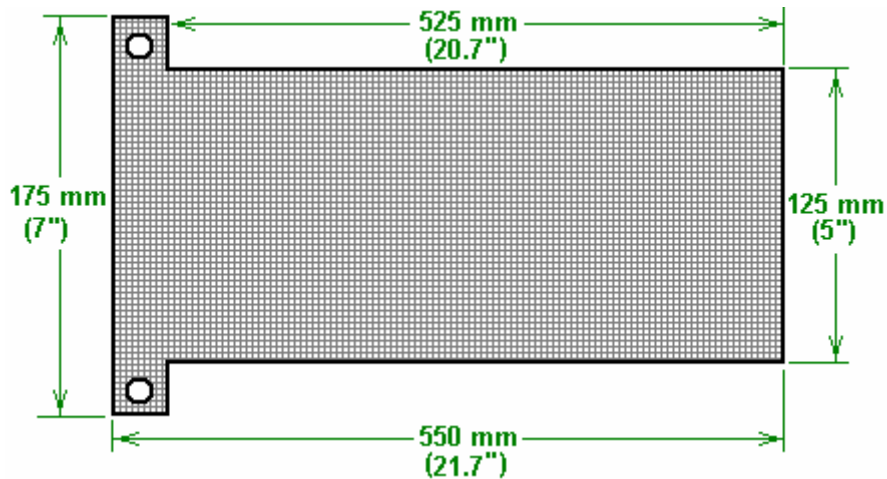

and:

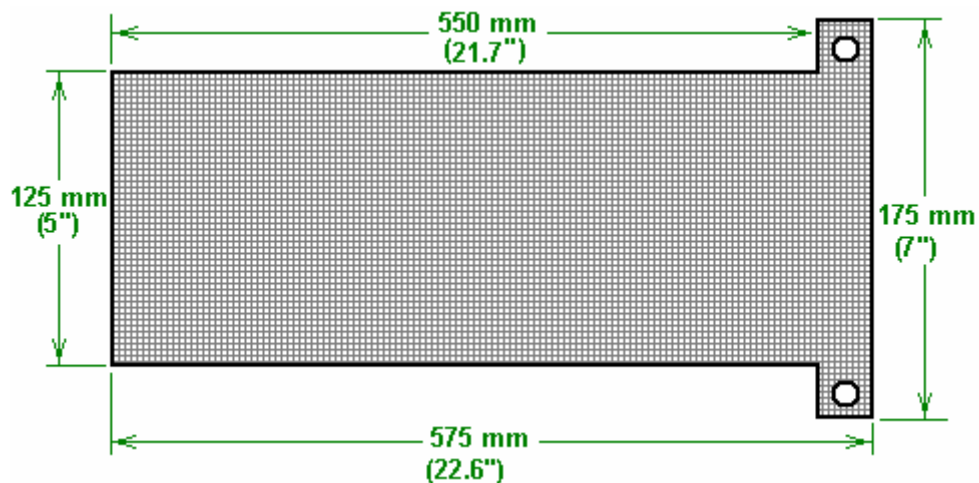

The mesh material looks like this:



The six electrolyser cells and the single large bubbler are constructed using standard plastic plumbing materials:

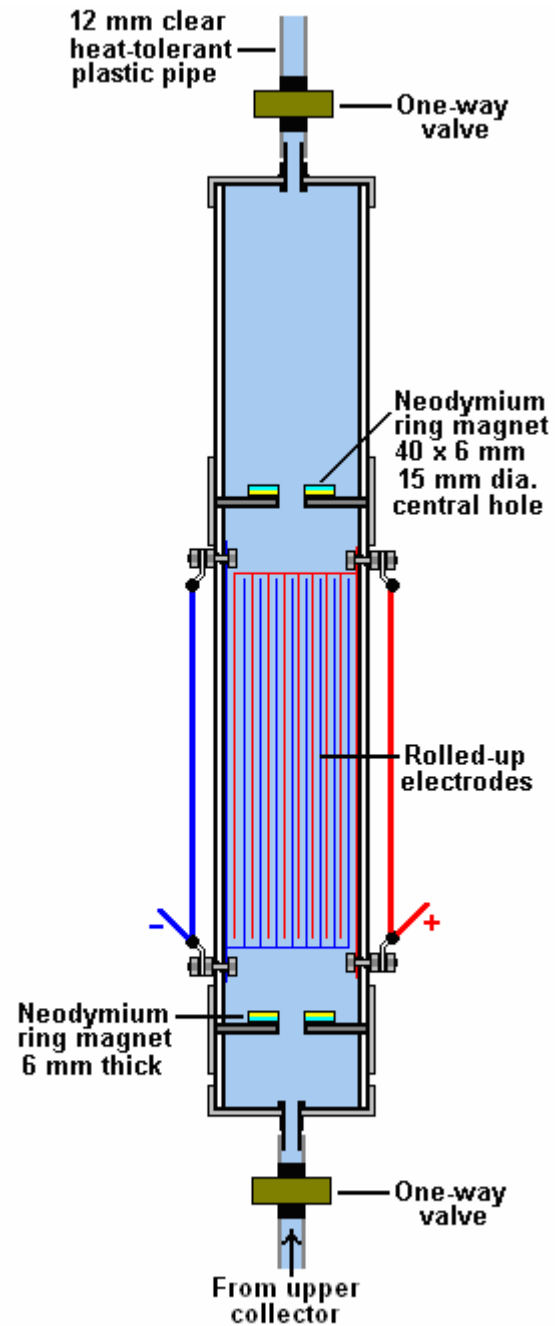
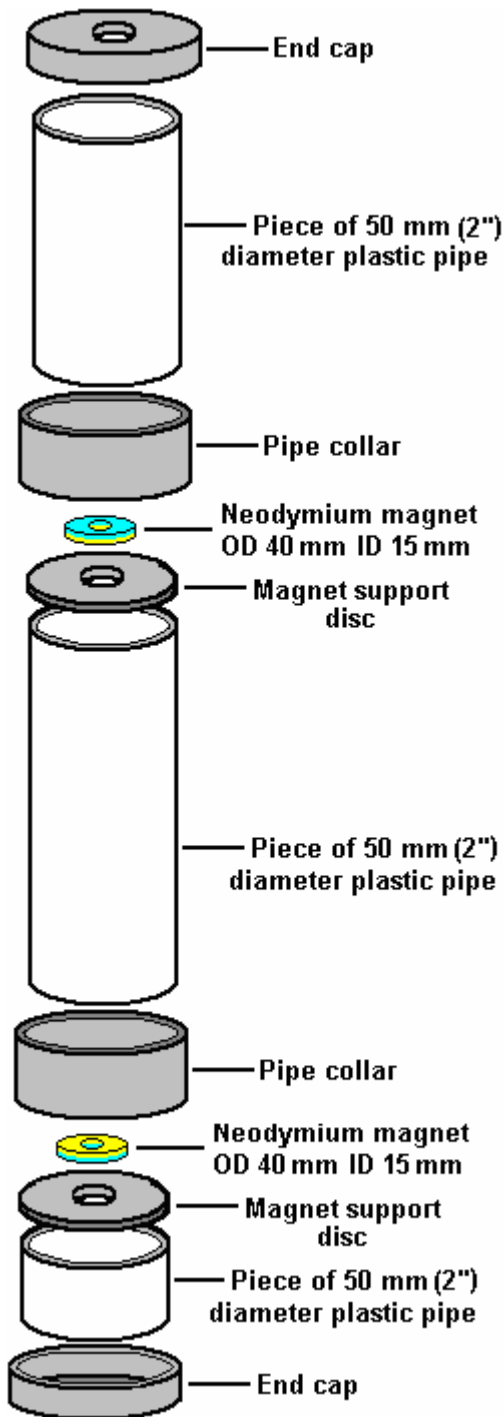

ONE ELECTROLYSER CELL

The connecting pipes are a clear plastic, heat-tolerant type of 12 mm (0.5") diameter. The bubbler is also constructed from plastic pipe fittings:

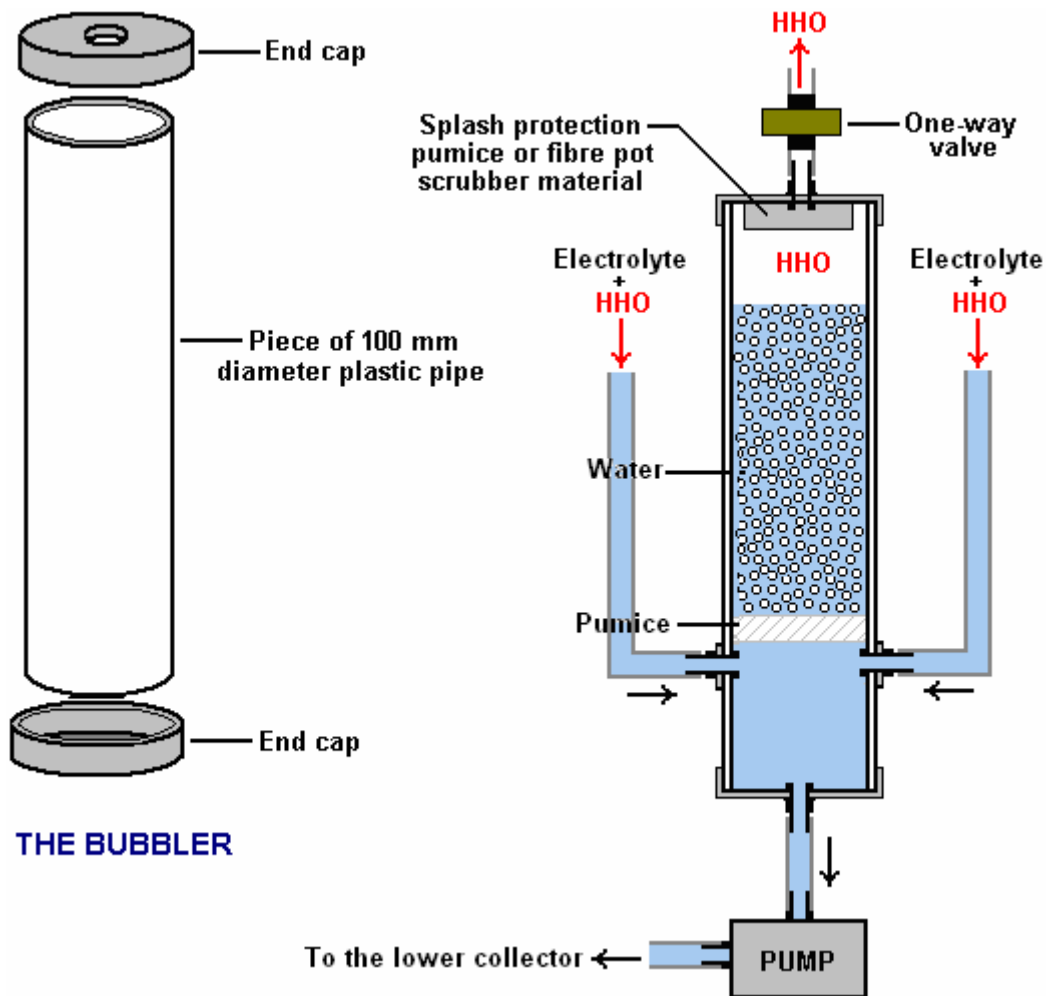

THE BUBBLER

As some people have difficulty in visualising the way in which the electrodes are combined, this simplified concept sketch may be helpful:

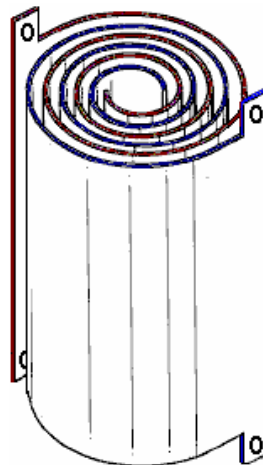

The two electrodes are kept separated by the use of small diameter fibre washers held in place between them at strategic places using super glue. The mesh itself is then treated by being immersed in citric acid in order to make it work well with rainwater.

There are three of these pairs of electrolyser cells, each pair being connected to the upper collector reservoir. The water being pumped out of each cell is passed through one of the three filters before entering the collector reservoir which feeds the small pump which keeps the water circulating which in turn keeps removing any particles which have got into the rainwater.

When used with rainwater from a barrel, this electrolyser is said to draw just 1.4 amps per cell, giving a total input of about 115 watts when run on a 12-volt electrical supply. While rainwater is supposedly pure, the reality is that it seldom is and it's ability to carry a current varies dramatically from place to place and even more widely from

country to country. If you decide to build this electrolyser and find that you do not get anything like 1.4 amps flowing through any one cell, then you may well have to add a small amount of electrolyte to the water in order to get the current flowing. That is, assuming that you want a current flow of 1.4 amps per cell on 12 volts. The output of this electrolyser is said to be capable of running a small electrical generator but that has not been confirmed at this time.

Advanced DC Boosters.

All of the practical construction details on electrical safety, gas safety, engine connections, type of water, safe mixing of electrolyte, etc. already discussed, apply to all kinds of electrolysers and boosters of every design. So, please understand that these are universal features which need to be understood when using any design of booster.

It is possible to produce large volumes of hydroxy gas from a DC booster, enough gas to run a small motor directly on it. For this, we need to pay attention to the efficiency factors already covered in this document. The person who is outstanding in this field is Bob Boyce of the USA who has kindly shared his experience and expertise freely with people who want to use serious electrolysers.

Bob's attention to detail when constructing high-performance electrolysers has resulted in efficiencies which are more than double those of the very famous Michael Faraday whom most scientists consider to be the final word on electrolysis.

Bob Boyce's High-Efficiency Electrolyser.

We are now moving from the "casual" style of booster to the "serious" style of electrolyser. In this category, you will find that the units built are not cheap, weight a considerable amount, require considerable skill to make and usually are quite large physically. I will mention two designs here. First, the very well-known design from Bob Boyce. For this electrolyser, Bob makes solid stainless steel electrode plates act as cell partitions as well as being electrodes. This is a clever technique but it takes a very high level of construction accuracy to make a box with slots in the side and base, so that the stainless steel plates can be slid into the box and when there, form a watertight seal between the cells, preventing electrical current bypassing the plates by flowing around them.

The number of cells in the electrolyser depends on the electrical DC voltage supply which is produced from the electrics of the vehicle. This higher voltage is created by using a standard off-the-shelf "inverter" which produces high-voltage alternating current ("AC") meant to be the equivalent of the local electricity mains supply. In the USA, the voltage produced is in the 110 to 120 volt region, elsewhere, it is in the 220 to 230 volt region.

If you are not familiar with electrical jargon, then check out chapter 12 which explains it step by step. The AC output from whatever inverter you buy, is changed back into DC by using a component called a "diode bridge" and a reservoir device called a capacitor. When this is done, the resulting DC voltage is 41% greater than the quoted AC voltage, so a 110-volt inverter will produce about 155 volts and a 220-volt inverter about 310 volts. As you want about 2 volts per cell, the number of cells would be about 80 or 150 depending on which inverter is used. This large number of stainless steel plates each sized at six-inches (150 mm) square, creates a substantial weight which then is increased by the weight of the case, and the electrolyte. The overall arrangement (without the capacitor) is like this:

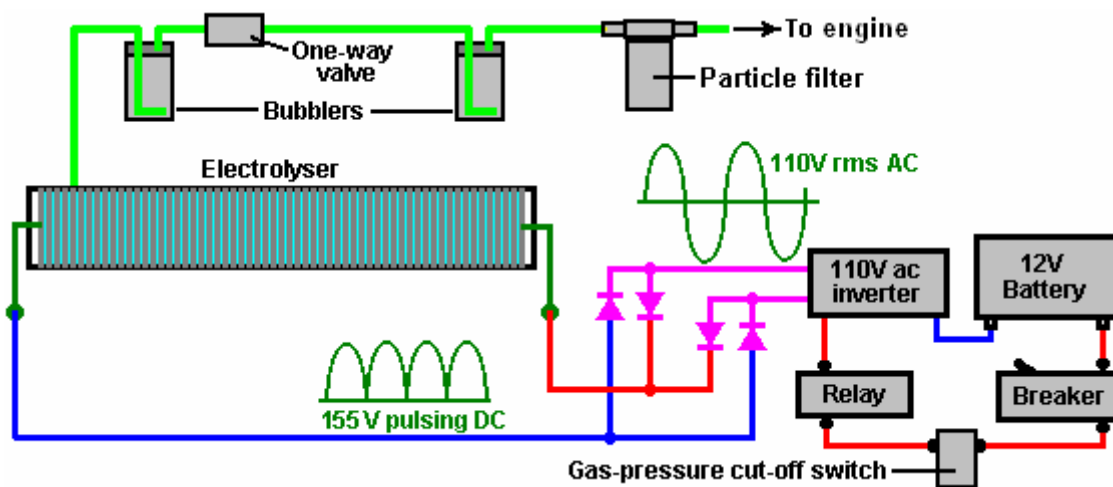

A very high-precision box for this style of electrolyser can be had from **Ed Holdgate** of Florida who has also shared the construction methods if you fancy yourself as a skilled fabricator:



Ed's website is at <http://www.holdgateenterprises.com/Electrolyzer/index.html> and each case is hand-made.

The gas production rate is so high that the gas outlet pipe has to have holes drilled along the top in order to try to exclude spray and moisture from the massive rate of bubbles bursting at the surface of the electrolyte. The high efficiency of Bob's electrolyzers is due to his meticulous preparation and construction methods. You will notice that Bob recommends the use of a particle filter with a 1-micron mesh, between the engine and the hydroxy system. Apart from ensuring that everything entering the engine is very clean, the particle filter with a mesh of that small size, also acts as a flashback-preventer as flame can't pass through it.

Firstly, the stainless steel plates are cross-scored with sandpaper to create a specially shaped plate surface which helps high-speed bubble release. Secondly, the plates are put through a rigorous "cleansing" process where they are subjected to repeated periods of electrolysis followed by rinsing particles off the plates and filtering the electrolyte solution. When no further particles break free from the plates, they are then put through a "conditioning" process which develops a catalytic layer on the plate surfaces.

This processing and the various construction details are provided in the following free download document, thanks to Bob's generosity in sharing his experience with us: <http://www.free-energy-info.com/D9.pdf> and there is a forum for Bob's design: <http://tech.groups.yahoo.com/group/WorkingWatercar/> where questions are answered.

Pulsed Water-Splitters.

There is a much more efficient way of converting water into a hydroxy gas mix. Unlike the electrolysis devices already described, this method does not need an electrolyte. Pioneered by Stanley Meyer, pulse trains are used to stress water molecules until they break apart, forming the required gas mix. Henry Puharich also developed a very successful system with a somewhat different design. Neither of these gentlemen shared sufficient practical information for us to replicate their designs as a routine process, so we are in a position today where we are searching for the exact details of the methods which they used.

Dave Lawton's Replication of Stan Meyer's "Water Fuel Cell".

The first significant replication of which I am aware, came from Dave Lawton of Wales. By using very considerable tenacity, he discovered the practical details of how to replicate one of Stan Meyer's early designs which is called by the rather confusing name of the "Water Fuel Cell". Dave's work was copied and experimented with by Ravi Raju of India who had considerable success and who posted videos of his results on the web. More recently, Dr Scott Cramton of the USA has adapted the design construction slightly and achieved very satisfactory rates of electrical efficiency, producing some 6 lpm of hydroxy gas for just 3 amps of current at 12 volts.



Dave Lawton

The video of Dave Lawton's replication of Stanley Meyer's demonstration electrolyser (not Stan's production system) seen at <http://www.free-energy-info.com/WFCrep.wmv> has caused several people to ask for more details.

The electrolysis shown in that video was driven by an alternator, solely because Dave wanted to try each thing that Stan Meyer had done. Dave's alternator and the motor used to drive it are shown here:

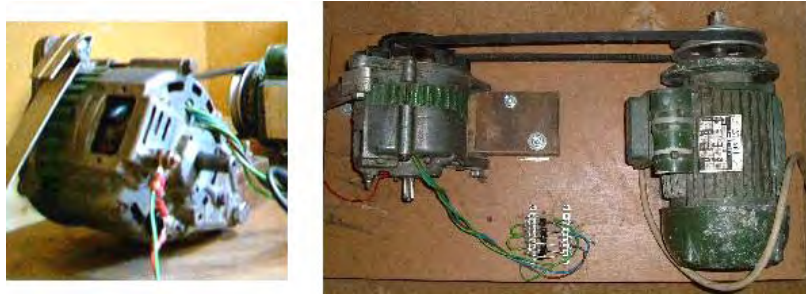

The technique of DC pulsing requires the use of electronics, so the following descriptions contain a considerable amount of circuitry. If you are not already familiar with such circuits, then you would be well advised to read through Chapter 12 which explains this type of circuitry from scratch.

The field coil of Dave's alternator is switched on and off by a Field-Effect Transistor (a "FET") which is pulsed by a dual 555 timer circuit. This produces a composite waveform which produces an impressive rate of electrolysis. The tubes in this replication are made of 316L grade stainless steel, five inches long although Stan's tubes were about sixteen inches long. The outer tubes are 1 inch in diameter and the inner tubes 3/4 inch in diameter. As the wall thickness is 1/16 inch, the gap between them is between 1 mm and 2 mm. The inner pipes are held in place at each end by four rubber strips about one quarter of an inch long.

The container is made from two standard 4 inch diameter plastic drain down-pipe coupler fittings connected to each end of a piece of acrylic tube with PVC solvent cement. The acrylic tube was supplied already cut to size by Wake Plastics, 59 Twickenham Road, Isleworth, Middlesex TW7 6AR Telephone 0208-560-0928. The seamless stainless steel tubing was supplied by: <http://www.metalsontheweb.co.uk/asp/home.asp>

It is not necessary to use an alternator - Dave just did this as he was copying each thing that Stan Meyer did. The circuit without the alternator produces gas at about the same rate and obviously draws less current as there is no drive motor to be powered. A video of the non-alternator operation can be downloaded using this link: <http://www.free-energy-info.co.uk/WFCrep2.wmv>.

Dave's electrolyser has an acrylic tube section to allow the electrolysis to be watched, as shown here:



The electrolysis takes place between each of the inner and outer tubes. The picture above shows the bubbles just starting to leave the tubes after the power is switched on. The picture below shows the situation a few seconds later when the whole of the area above the tubes is so full of bubbles that it becomes completely opaque:



The mounting rings for the tubes can be made from any suitable plastic, such as that used for ordinary food-chopping boards, and are shaped like this:



And the 316L grade stainless steel, seamless tubes are held like this:



Here is the assembly ready to receive the inner tubes (wedged into place by small pieces of rubber):



The electrical connections to the pipes are via stainless steel wire running between stainless steel bolts tapped into the pipes and stainless steel bolts running through the base of the unit:

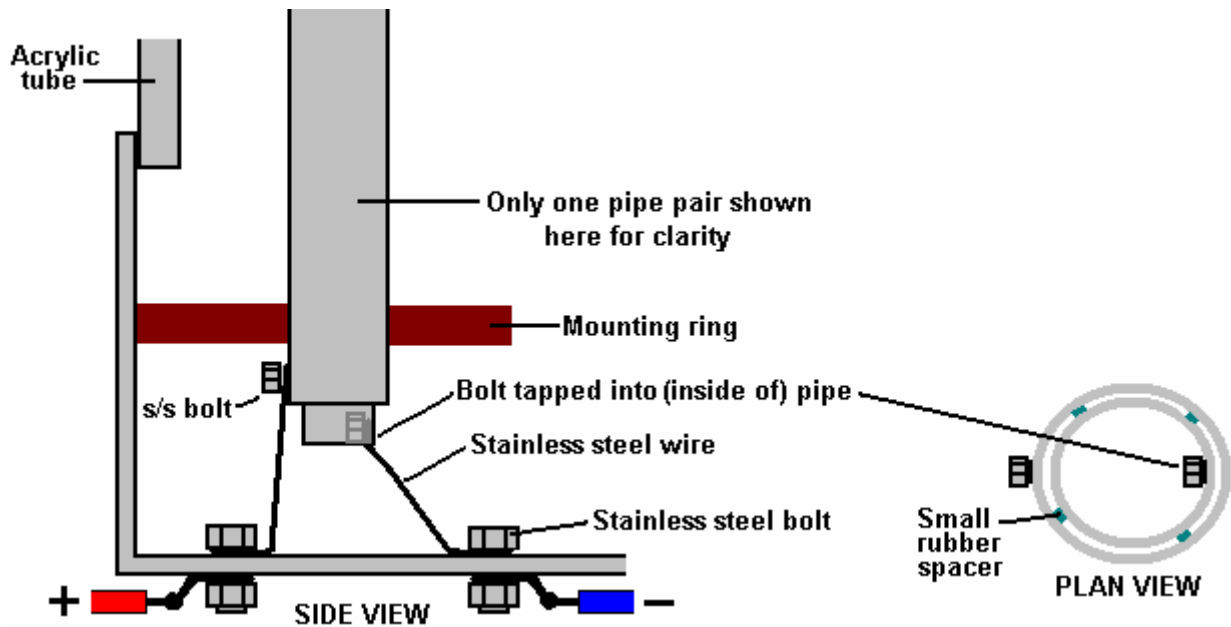

The bolts tapped into the inner tubes should be on the inside. The bolts going through the base of the unit should be tapped in to give a tight fit and they should be sealed with Sikaflex 291 or marine GOOP bedding agent which should be allowed to cure completely before the unit is filled for use. An improvement in performance is produced if the non-active surfaces of the pipes are insulated with any suitable material. That is, the outsides of the outer tubes and the insides of the inner tubes, and if possible, the cut ends of the pipes.

Stan Meyer's Style of Construction.

While Dave's style of construction is simple and straightforward, recently, a copy of one of Stan Meyer's actual construction drawings has surfaced. The image quality of this copy is so low that much of the text can't be read, so the replication presented here may not be exact or might be missing some useful item of information. Stan's construction is unusual. First, a piece of plastic is shaped as shown here:

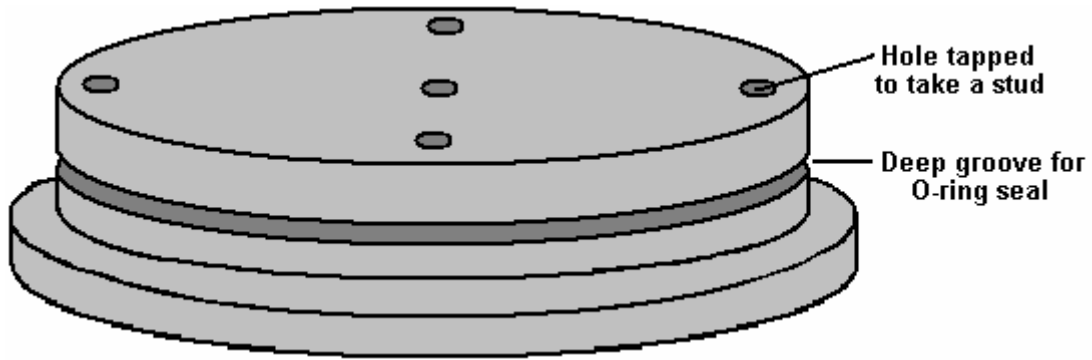

The size of this disc is matched exactly to the piece of clear acrylic used for the body of the housing. The drawing does not make it clear how this disc is attached to the acrylic tube, whether it is a tight push fit, glued in place or held in position with bolts which are not shown. The implication is that a ring of six bolts are driven through the top and tapped into the acrylic tube, as these are shown on one of the plan views, though not on the cross-section. It would also be reasonable to assume that a similar ring of six bolts is also used to hold the base securely in position. There is a groove cut in the plastic base to take an O-ring seal which will be compressed tightly when the disc is in place. There are either two or three threaded stud recesses plus two through holes to carry the electric current connections. The pipe support arrangement is unusual:

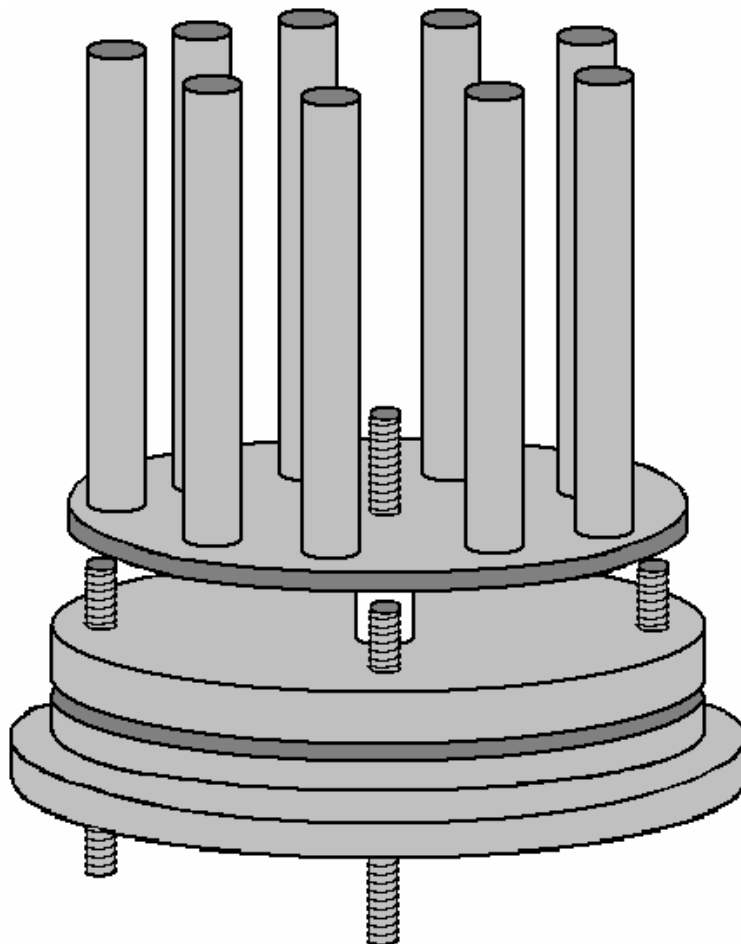

A ring of nine evenly-spaced inner pipes are positioned around the edge of a steel disc which is slightly smaller than the inside dimension of the acrylic tube. The pipes appear to be a tight push-fit in holes drilled very accurately through the disc. These holes need to be exactly at right-angles to the face of the disc in order for the pipes to be exactly aligned with the acrylic tube – definitely a drill-press job. The disc is mounted on a central threaded rod which projects through the plastic base disc, and a plastic spacer is used to hold the disc clear of the studs positioned at ninety degrees apart around the outer edge of the base disc.

The mounting for the outer tubes is also most unusual. A piece of steel plate is cut with nine projecting arms at evenly-spaced positions around a circular washer shape as shown here:

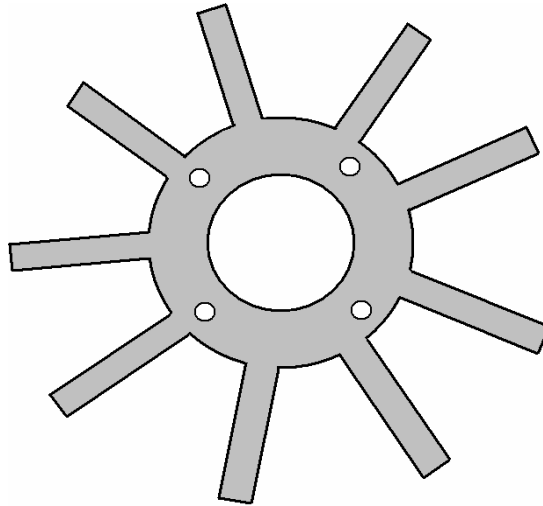

This piece has four holes drilled in it to match the stud positions of the plastic base piece. The number of studs is not specified and while I have shown four, the plate resonance might be helped if there were just three. The size is arranged so that when the arms are bent upwards at right-angles, they fit exactly against the inner face of the acrylic tube.

These arms get two bends in them in order to kink them inwards to form mounts for the outer tubes. The degree of accuracy needed here is considerable as it appears that there are no spacers used between the inner and outer tubes. This means that the very small gap of 1.5 mm or so has to be maintained by the accuracy of these mounts for the outer tubes.

It should be noted that the inner tubes are much longer than the outer tubes and that the outer tubes have a tuning slot cut in them. All of the inner tubes are mechanically connected together through their steel mounting disc and all of the outer tubes are connected together through the ring-shaped steel disc and its kinked arm mounts. It is intended that both of these assemblies should resonate at the same frequency, and they are tuned to do just that. Because the inner tubes have a smaller diameter, they will resonate at a higher frequency than a larger diameter pipe of the same length. For that reason, they are made longer to lower their natural resonant frequency. In addition to that, the slots cut in the outer tubes are a tuning method which raises their resonant pitch. These slots will be adjusted until every pipe resonates at the same frequency.

Looking initially at the mechanical design, suggests that the assembly is impossible to assemble, and while that is almost true, as it will have to be constructed as it is assembled and it appears that the inner and outer pipe assembly can't be taken apart after assembly. This is the way they are put together:

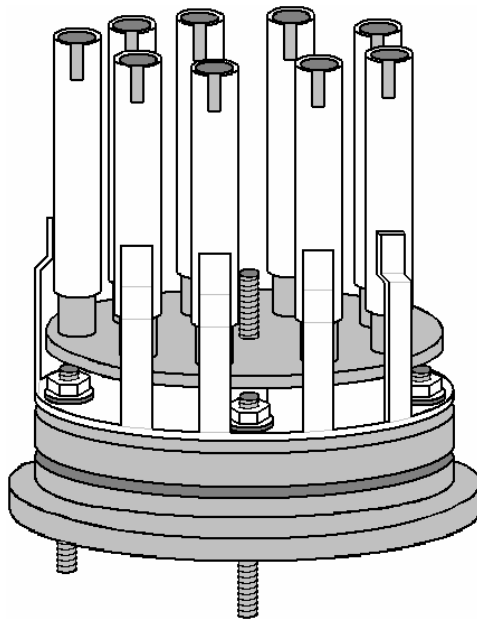

The ring support for the outer pipes is not bolted securely to the plastic base but instead it is spaced slightly above it and mounted on just the stud points. This ring is underneath the slightly smaller diameter disc which holds the inner pipes. This makes it impossible for the two components to be slid together or apart, due to the length of the

pipes. This suggests that either the inner pipes are pushed into place after assembly (which is highly unlikely as they will have been assembled before for tuning) or that the outer pipes are welded to their supports during the assembly process (which is much more likely).

One of the “studs” is carried right through the plastic base in order that it can become the positive connection of the electrical supply, fed to the outer pipes. The central threaded rod is also carried all the way through the plastic base and is used to support the steel plate holding the inner pipes as well as providing the negative electrical connection, often referred to as the electrical “ground”.

Another plastic disc is machined to form a conical lid for the acrylic tube, having a groove to hold an O-ring seal and the water inlet for refilling and the gas output tube. The drawing mentions the fact that if tap water is used, then the impurities in it will collect in the bottom of the electrolyser when the water is removed by being converted to hydroxy gas. This means that the cell would have to be rinsed out from time to time. It also draws attention to the fact that the gasses dissolved in the tap water will also come out during use and will be mixed with the hydroxy gas output.

When these various components are put together, the overall cell construction is shown like this:

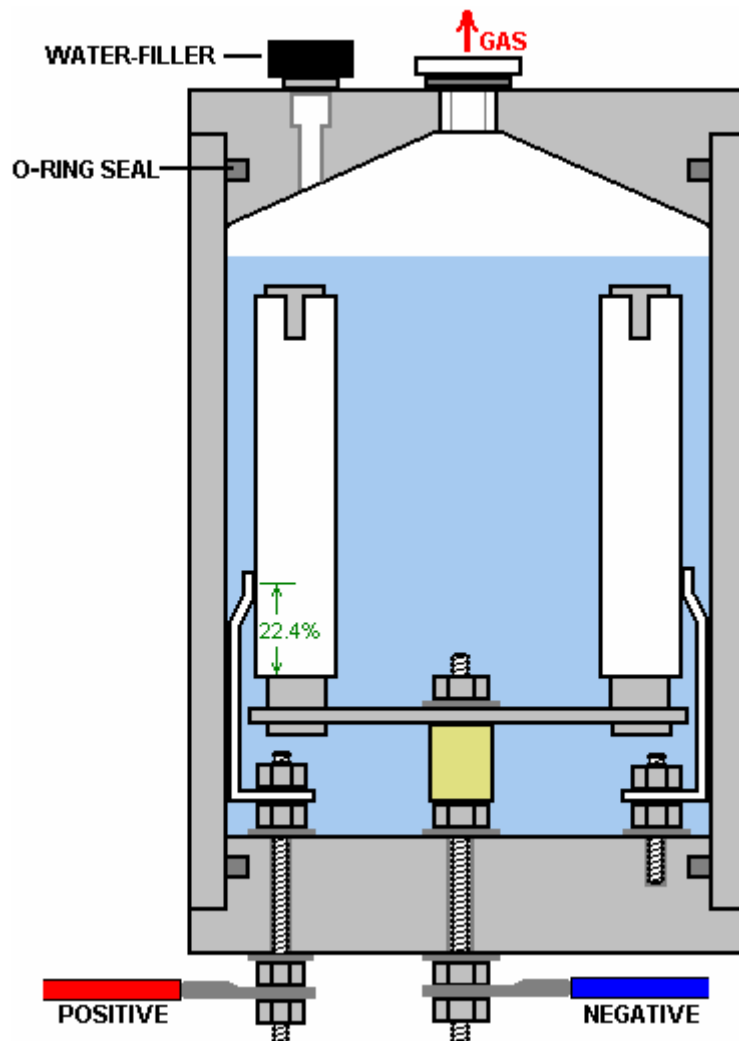

This cross-sectional view may be slightly misleading as it suggests that each of the nine outer pipes has its own separate bracket and this is probably not the case as they are connected together electrically through the steel ring-shaped disc and should vibrate as a single unit. It is tempting to use separate brackets as that would allow the assembly to be taken apart quite easily, but the electrical contacts of such a system would be much inferior and so it is not to be recommended.

Because of the way that all of the inner pipes are connected together and all of the outer pipes are connected together electrically, this form of construction is not suited to the three-phase alternator drive shown below, where the nine pipes would have to be connected in separate sets of three. Instead, the solid-state circuit is used, which

is very effective and which does not have the size, weight, noise and increased current of the alternator arrangement.

If accuracy of construction is a problem, then it might be possible to give the outer pipes a deliberate slope so that they press against the inner pipes at the top, and then use one short spacer to force them apart and give the desired spacing. It seems clear that Stan worked to such a degree of constructional accuracy that his pipes were perfectly aligned all along their lengths.

Dave Lawton points out that the connection point of the brackets for the outer pipes is highly critical as they need to be at a resonating node of the pipes. The connection point is therefore at 22.4% of the length of the pipe from the bottom of the pipe. Presumably, if a slot is cut in the top of the pipe, then the resonant pipe length will be measured to the bottom of the slot and the connection point set at 22.4% of that length.

Dave Lawton's 3-Phase Circuit.

Dave Lawton's pipe arrangement can be driven either via an alternator or by an electronic circuit. A suitable circuit for the alternator arrangement is:

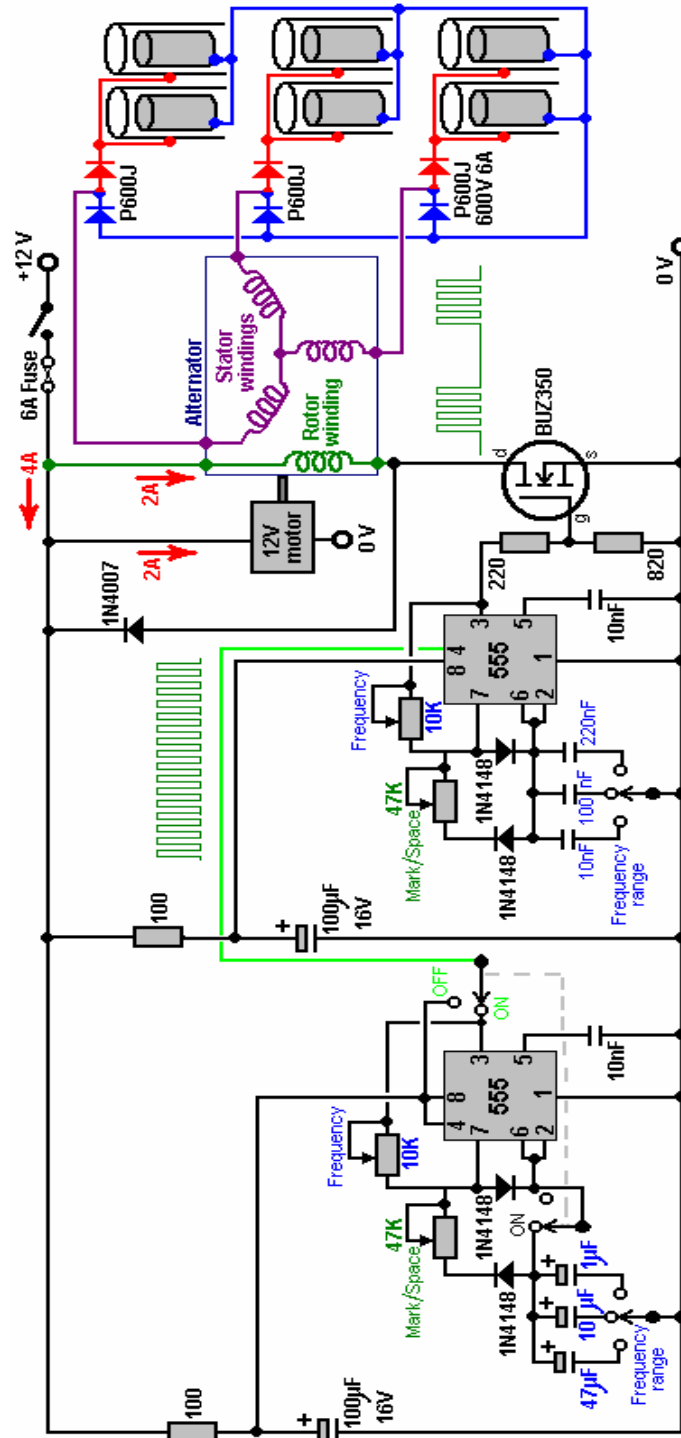

In this rather unusual circuit, the rotor winding of an alternator is pulsed via an oscillator circuit which has variable frequency and variable Mark/Space ratio and which can be gated on and off to produce the output waveform shown below the alternator in the circuit diagram. The oscillator circuit has a degree of supply de-coupling by the 100 ohm resistor feeding the 100 microfarad capacitor. This is to reduce voltage ripple coming along the +12 volt supply line, caused by the current pulses through the rotor winding. The output arrangement feeding the pipe electrodes of the electrolyser is copied directly from Stan Meyer's circuit diagram.

It is not recommended that you use an alternator should you decide to build a copy of your own. But if you decide to use one and the alternator does not have the windings taken to the outside of the casing, it is necessary to open the alternator, remove the internal regulator and diodes and pull out three leads from the ends of the stator windings. If you have an alternator which has the windings already accessible from the outside, then the stator winding connections are likely to be as shown here:

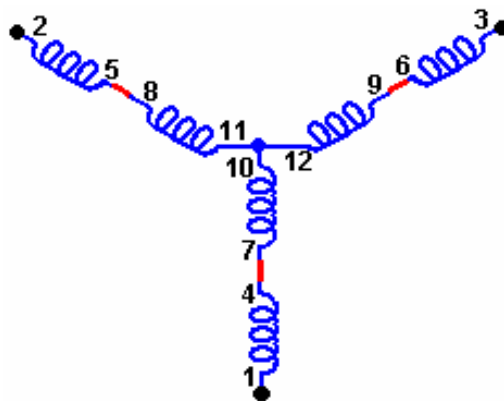

The motor driving Dave's alternator draws about two amps of current which roughly doubles the power input to the circuit. There is no need for the size, weight, noise, mechanical wear and current draw of using a motor and alternator as pretty much the same performance can be produced by the solid-state circuit with no moving parts.

Both circuits have been assessed as operating at anything from 300% to 900% of Faraday's "maximum electrical efficiency", it should be stressed that the inductors used in this circuit, form a very important role in altering and amplifying the voltage waveform applied to the cell. Dave uses two "bi-filar wound" inductors, each wound with 100 turns of 22 SWG (21 AWG) enamelled copper wire on a 9 mm (3/8") diameter ferrite rod. The length of the ferrite rod is not at all critical, and a ferrite toroid could be used as an alternative, though that is more difficult to wind. These bi-filar coils are wound at the same time using two lengths of wire side by side. The solid-state circuit is shown here:

Dave Lawton's Single-Phase Circuit:

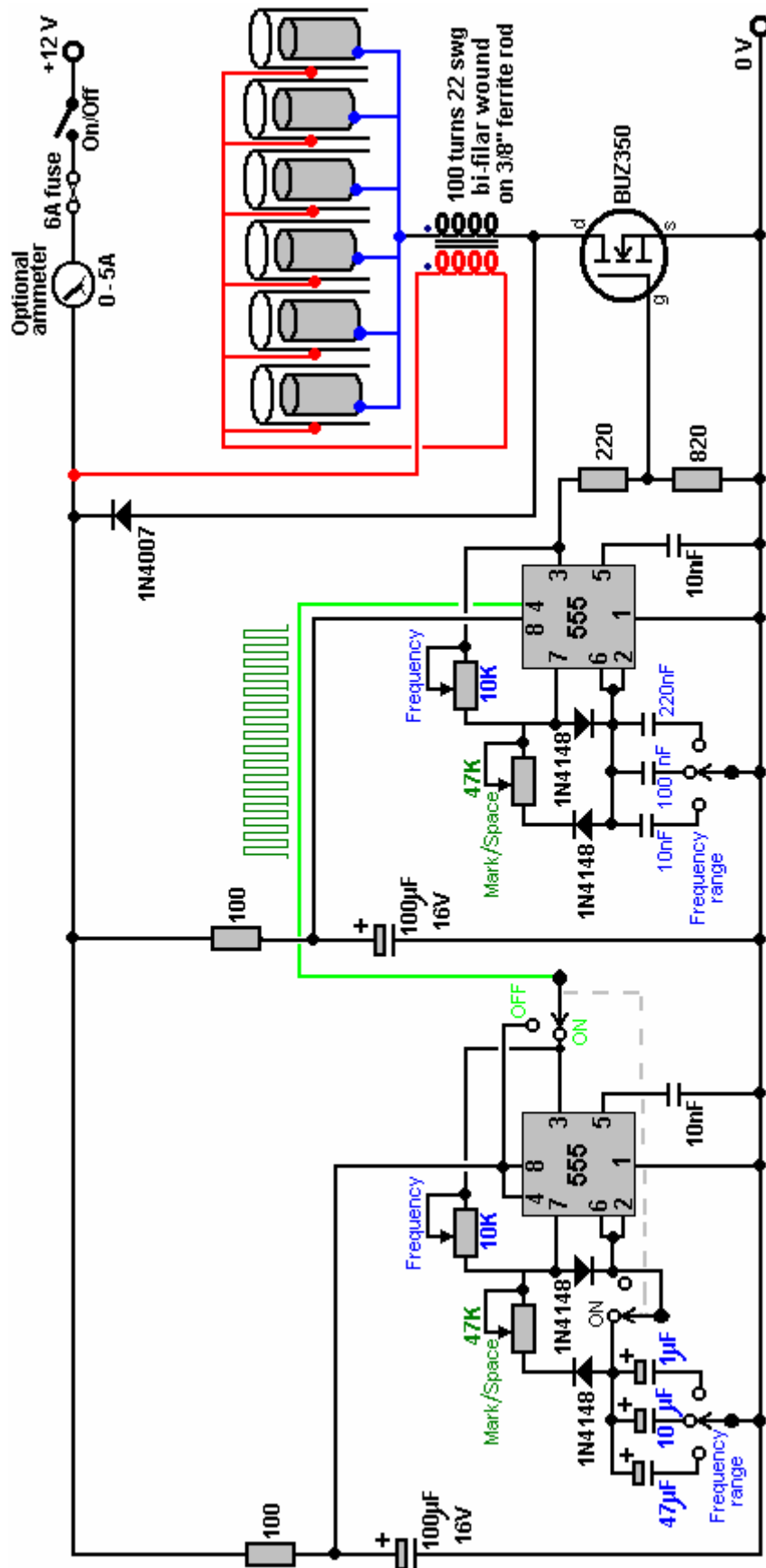

Circuit operation:

The main part of the circuit is made up of two standard 555 chip timers. These are wired to give an output waveform which switches very rapidly between a high voltage and a low voltage. The ideal waveform shape coming from this circuit is described as a "square wave" output. In this particular version of the circuit, the rate at which the circuit flips between high and low voltage (called the "frequency") can be adjusted by the user turning a knob. Also, the length of the ON time to the OFF time (called the "Mark/Space Ratio") is also adjustable.

This is the section of the circuit which does this:

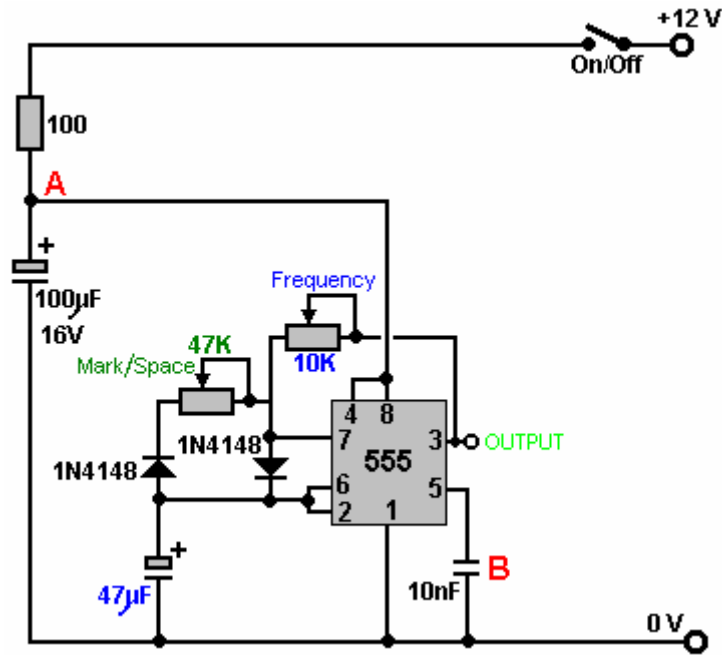

The 100 ohm resistor and the 100 microfarad capacitor are there to iron out any ripples in the voltage supply to the circuit, caused by fierce pulses in the power drive to the electrolysis cell. The capacitor acts as a reservoir of electricity and the resistor prevents that reservoir being suddenly drained if the power supply line is suddenly, and very briefly, pulled down to a low voltage. Between them, they keep the voltage at point "A" at a steady level, allowing the 555 chip to operate smoothly.

The very small capacitor "B" is wired up physically very close to the chip. It is there to short-circuit any stray, very short, very sharp voltage pulses picked up by the wiring to the chip. It is there to help the chip to operate exactly as it is designed to do, and is not really a functional part of the circuit. So, for understanding how the circuit works, we can ignore them and see the circuit like this:

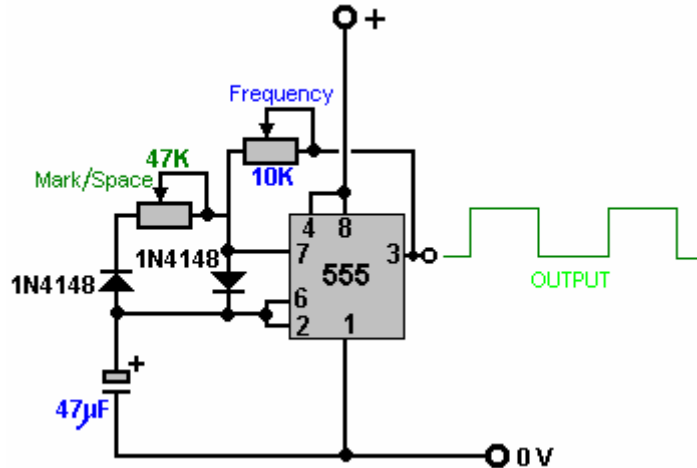

This circuit generates output pulses of the type shown in green with the voltage going high, (the "Mark") and low (the "Space"). The 47K variable resistor (which some people insist on calling a "pot") allows the length of the Mark and the Space to be adjusted from the 50 - 50 shown, to say, 90 - 10 or any ratio through to 10 - 90. It should be mentioned that the "47K" is not at all critical and these are quite likely to be sold as "50K" devices. Most low cost components have a plus or minus 10% rating which means that a 50K resistor will be anything from 45K to 55K in actual value.

The two "1N4148" diodes are there to make sure that when the Mark/Space 47K variable resistor is adjusted, that it does not alter the frequency of the output waveform in any way. The remaining two components: the 10K variable resistor and the 47 microfarad capacitor, both marked in blue, control the number of pulses produced per

second. The larger the capacitor, the fewer the pulses per second. The lower the value of the variable resistor, the larger the number of pulses per second.

The circuit can have additional frequency tuning ranges, if the capacitor value is altered by switching in a different capacitor. So the circuit can be made more versatile by the addition of one switch and, say, two alternative capacitors, as shown here:

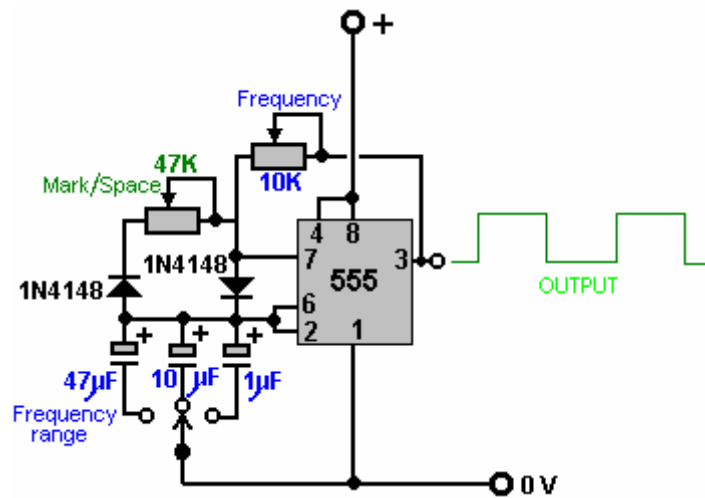

The capacitors shown here are unusually large because this particular circuit is intended to run relatively slowly. In the almost identical section of the circuit which follows this one, the capacitors are very much smaller which causes the switching rate to be very much higher. Experience has shown that a few people have had overheating in this circuit when it is switched out of action, so the On/Off switch has been expanded to be a two-pole changeover switch and the second pole used to switch out the timing elements of the 555 chip. The complete version of this section of the circuit is then:

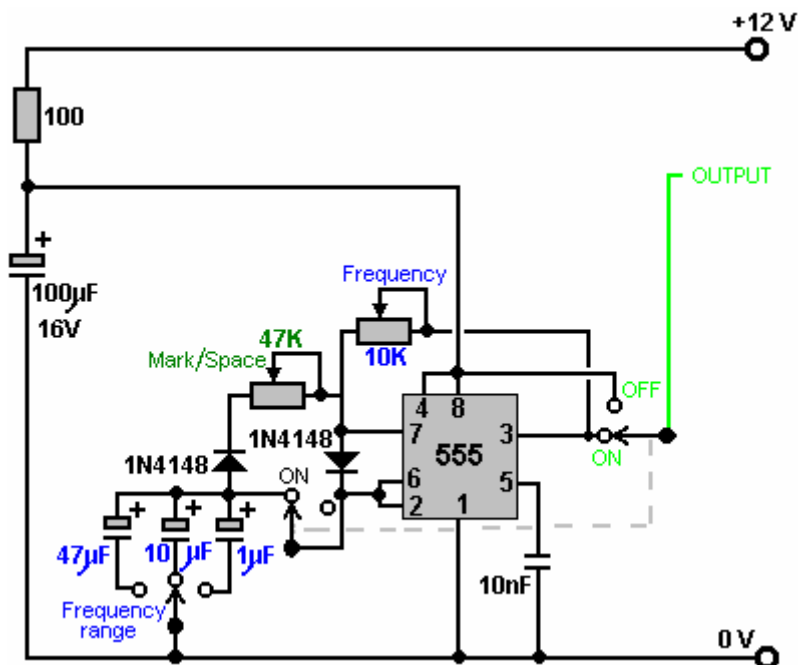

which just has one additional switch to allow the output to be stopped and the 12-volt supply line to be fed instead. The reason for this is that this part of the circuit is used to switch On and Off an identical circuit. This is called "gating" and is explained in Chapter 12 which is an electronics tutorial.

The second part of the circuit is intended to run at much higher speeds, so it uses much smaller capacitors:

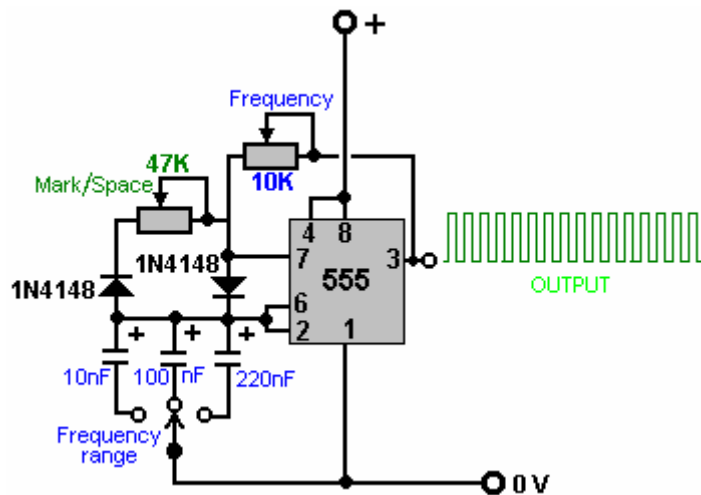

So, putting them together, and allowing the first circuit to switch the second one On and Off, we get:

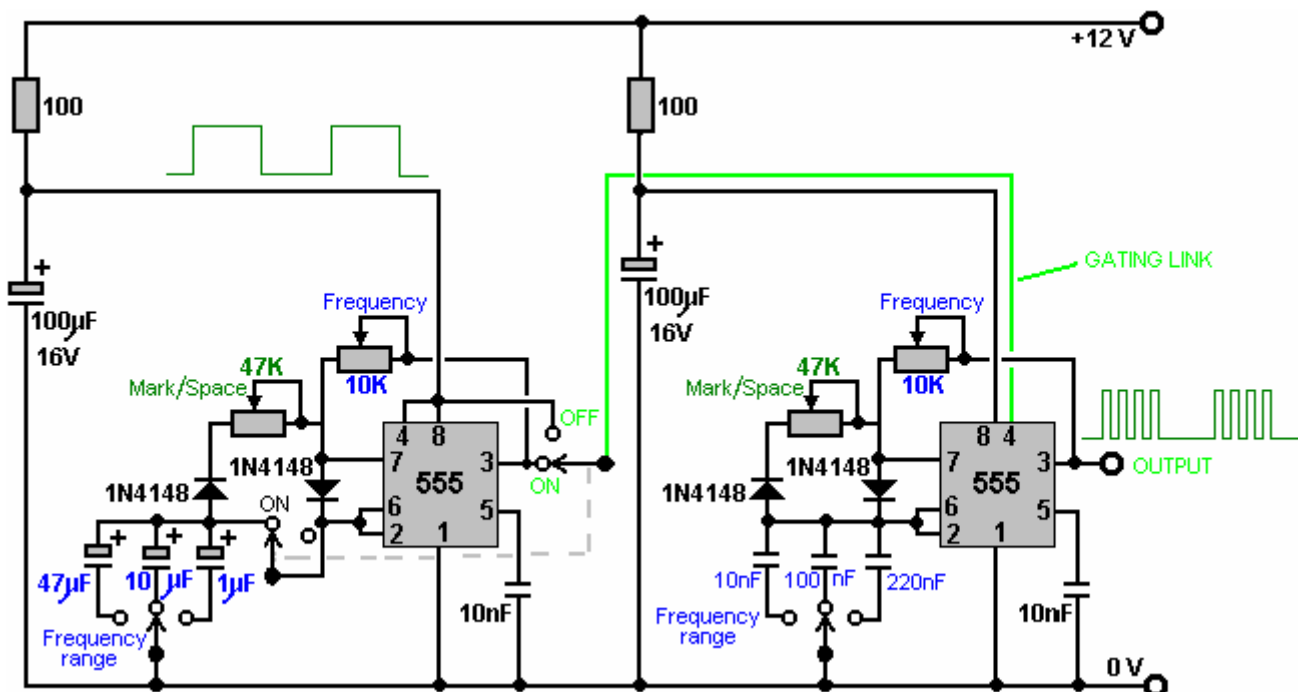

The final section of the circuit is the power drive for the electrolyser cell. This is a very simple circuit. Firstly, the output of the second 555 chip is lowered by a basic voltage-divider pair of resistors, and fed to the Gate of the output transistor which while it can run on the 12 volts which the pulse-generation circuit needs, Dave does prefer to run on 24 volts as that generates a greater gas flow:

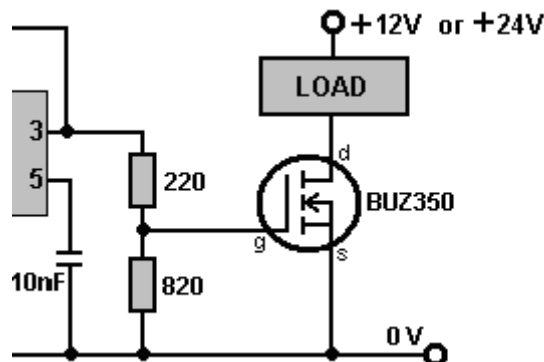

Here, the 555 chip output voltage is lowered by $220 / 820$ or about 27%. When the voltage rises, it causes the BUZ350 transistor to switch on, short-circuiting between its Drain and Source connections and applying the whole of the 12-volt supply voltage across the load, which in our application, is the electrolyser cell:

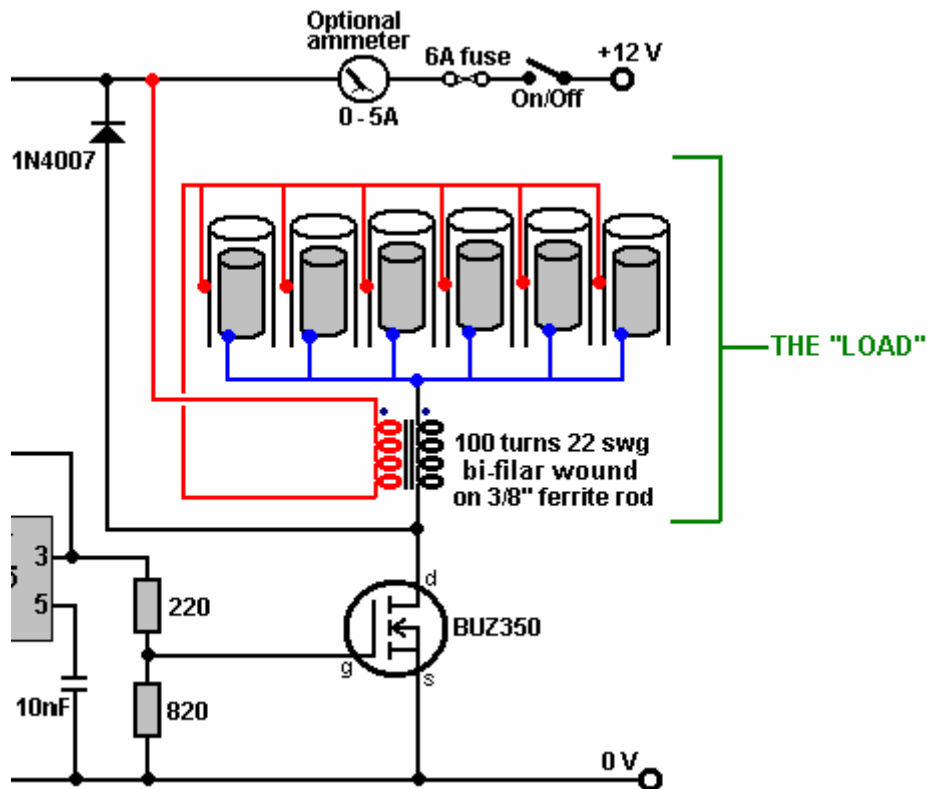

The transistor drives the electrolysis electrodes as shown above, applying very sharp, very short pulses to them. What is very important are the wire coils which are placed on each side of the electrode set. These coils are linked magnetically because they are wound together on a high-frequency ferrite rod core and although a coil is such a simple thing, these coils have a profound effect on how the circuit operates. Firstly, they convert the 555 chip pulse into a very sharp, very short, high-voltage pulse which can be as high as 1,200 volts. This pulse affects the local environment, causing extra energy to flow into the circuit. The coils now perform a second role by blocking that additional energy from short-circuiting through the battery, and causing it to flow through the electrolysis cell, splitting the water into a mix of hydrogen and oxygen, both gases being high-energy, highly charged atomic versions of those gases. This gives the mix some 400% the power of hydrogen being burned in air.

When the transistor switches off, the coils try to pull the transistor Drain connection down to a voltage well below the 0-volt battery line. To prevent this, a 1N4007 diode is connected across the cell and its coils. The diode is connected so that no current flows through it until the transistor Drain gets dragged down below the 0-volt line, but then that happens, the diode effectively gets turned over and as soon as 0.7 volts is placed across it, it starts to conduct heavily and collapses the negative voltage swing, protecting the transistor, and importantly, keeping the pulsed waveform restricted to positive DC pulses, which is essential for tapping this extra environmental energy which is what actually performs the electrolysis. You can easily tell that it is the environmental "cold" electricity which is doing the electrolysis as the cell stays cold even though it is putting out large volumes of gas. If the electrolysis were being done by conventional electricity, the cell temperature would rise during the electrolysis. A John Bedini pulser circuit can be used very effectively with a cell of this type and it adjusts automatically to the resonant frequency as the cell is part of the frequency-determining circuit.

The BUZ350 MOSFET has a current rating of 22 amps so it will run cool in this application. However, it is worth mounting it on an aluminium plate which will act as both the mounting and a heat sink but it should be realised that this circuit is a bench-testing circuit with a maximum current output of about 2 amps and it is **not** a Pulse-Width Modulation circuit for a high-current DC electrolyser. The current draw in this arrangement is particularly interesting. With just one tube in place, the current draw is about one amp. When a second tube is added, the current increases by less than half an amp. When the third is added, the total current is under two amps. The fourth and fifth tubes add about 100 milliamps each and the sixth tube causes almost no increase in current at all. This suggests that the efficiency could be raised further by adding a large number of additional tubes, but this is

actually not the case as the cell arrangement is important. Stan Meyer ran his VolksWagen car for four years on the output from four of these cells with 16-inch (400 mm) electrodes, and Stan would have made a single larger cell had that been feasible.

Although the current is not particularly high, a five or six amp circuit-breaker, or fuse, should be placed between the power supply and the circuit, to protect against accidental short-circuits. If a unit like this is to be mounted in a vehicle, then it is **essential** that the power supply is arranged so that the electrolyser is disconnected if the engine is switched off. Passing the electrical power through a relay which is powered via the ignition switch is a good solution for this. It is also **vital** that at least one bubbler is placed between the electrolyser and the engine, to give some protection if the gas should get ignited by an engine malfunction.

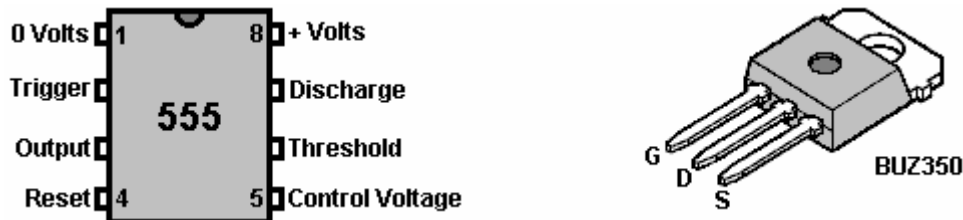

Although printed circuit boards have now been produced for this circuit and ready-made units are available commercially, you can build your own using stripboard if you want to. A possible one-off prototype style component layout for is shown here:

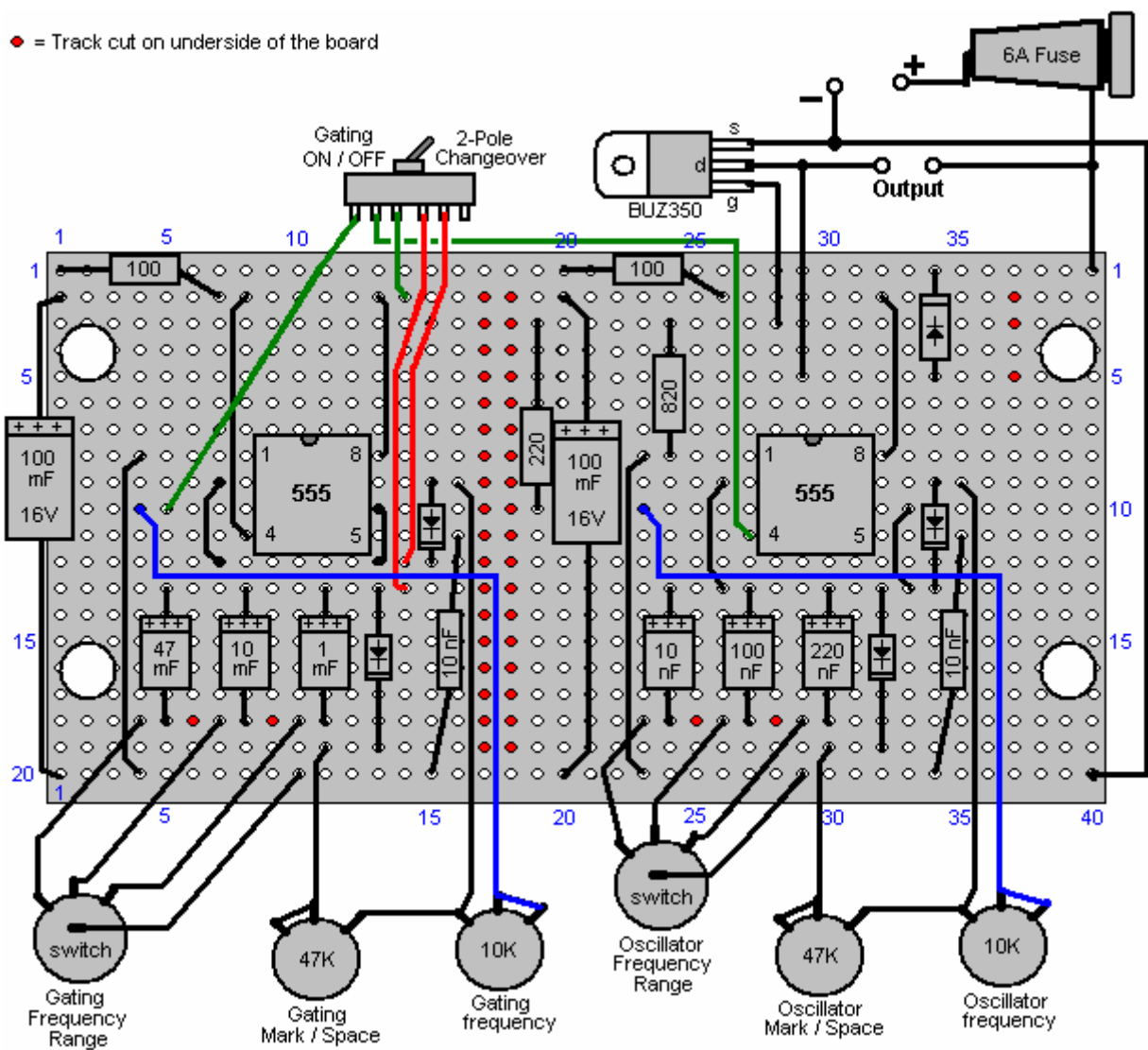

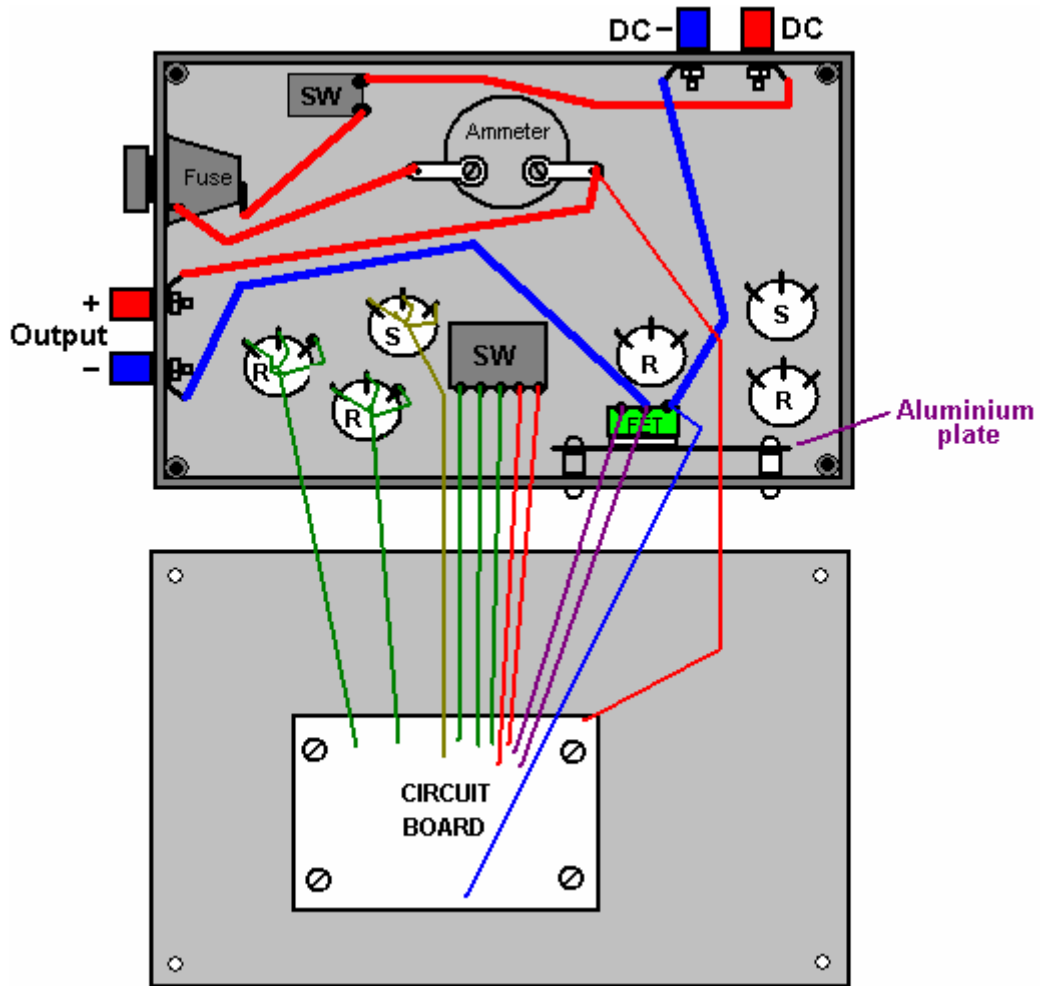

Although using a ferrite ring is probably the best possible option, the bi-filar coil can be wound on any straight ferrite rod of any diameter and length. You just tape the ends of two strands of wire to one end of the rod and then rotate the rod in your hands, guiding the strands into a neat side-by-side cylindrical winding as shown here:

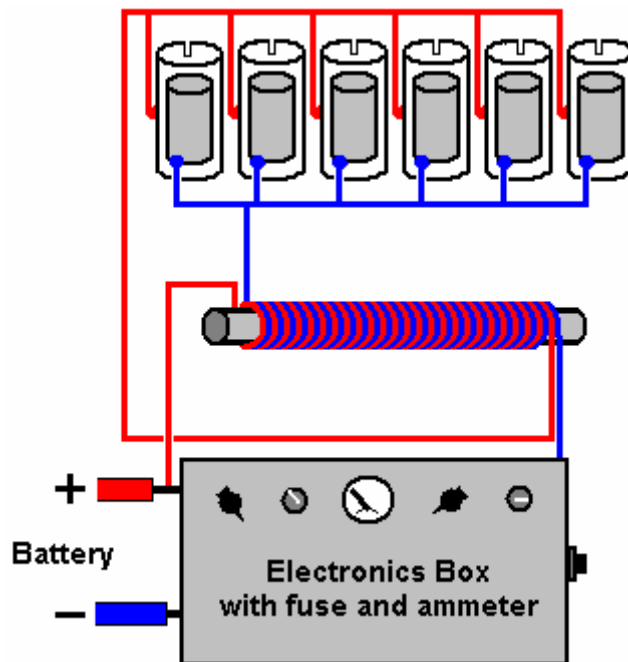

Component	Quantity	Description	Comment
100 ohm resistors 0.25 watt	2	Bands: Brown, Black, Brown	
220 ohm resistor 0.25 watt	1	Bands: Red, Red, Brown	
820 ohm resistor 0.25 watt	1	Bands: Gray, Red, Brown	
100 μ F 16V capacitor	2	Electrolytic	
47 μ F 16V capacitor	1	Electrolytic	
10 μ F 16V capacitor	1	Electrolytic	
1 μ F 16 V capacitor	1	Electrolytic	
220 nF capacitor (0.22 mF)	1	Ceramic or polyester	
100 nF capacitor (0.1 mF)	1	Ceramic or polyester	
10 nF capacitor (0.01 mF)	3	Ceramic or polyester	
1N4148 diodes	4		
1N4007 diode	1		FET protection
NE555 timer chip	2		
BUZ350 MOSFET	1	Or any 200V 20A n-channel MOSFET	
47K variable resistors	2	Standard carbon track	Could be screw track
10K variable resistors	2	Standard carbon track	Could be screw track
4-pole, 3-way switches	2	Wafer type	Frequency range
1-pole changeover switch	1	Toggle type, possibly sub-miniature	Any style will do
1-pole 1-throw switch	1	Toggle type rated at 10 amps	Overall ON / OFF switch
Fuse holder	1	Enclosed type or a 6A circuit breaker	Short-circuit protection
Veroboard	1	20 strips, 40 holes, 0.1 inch matrix	Parallel copper strips
8-pin DIL IC sockets	2	Black plastic, high or low profile	Protects the 555 ICs
Wire terminals	4	Ideally two red and two black	Power lead connectors
Plastic box	1	Injection moulded with screw-down lid	
Mounting nuts, bolts and pillars	8	Hardware for 8 insulated pillar mounts	For board and heatsink
Aluminium sheet	1	About 4 inch x 2 inch	MOSFET heatsink
Rubber or plastic feet	4	Any small adhesive feet	Underside of case
Knobs for variable resistors etc.	6	1/4 inch shaft, large diameter	Marked skirt variety
Ammeter	1	Optional item, 0 to 5A or similar	
Ferrite rod 1-inch long or longer	1	For construction of the inductors	bi-filar wound
22 SWG (21 AWG) wire	1 reel	Enamelled copper wire, 2 oz. reel	
Sundry connecting wire	4 m	Various sizes	

Dave, who built this replication, suggests various improvements. Firstly, Stan Meyer used a larger number of tubes of greater length. Both of those two factors should increase the gas production considerably. Secondly, careful examination of video of Stan's demonstrations shows that the outer tubes which he used had a rectangular slot cut in the top of each tube:

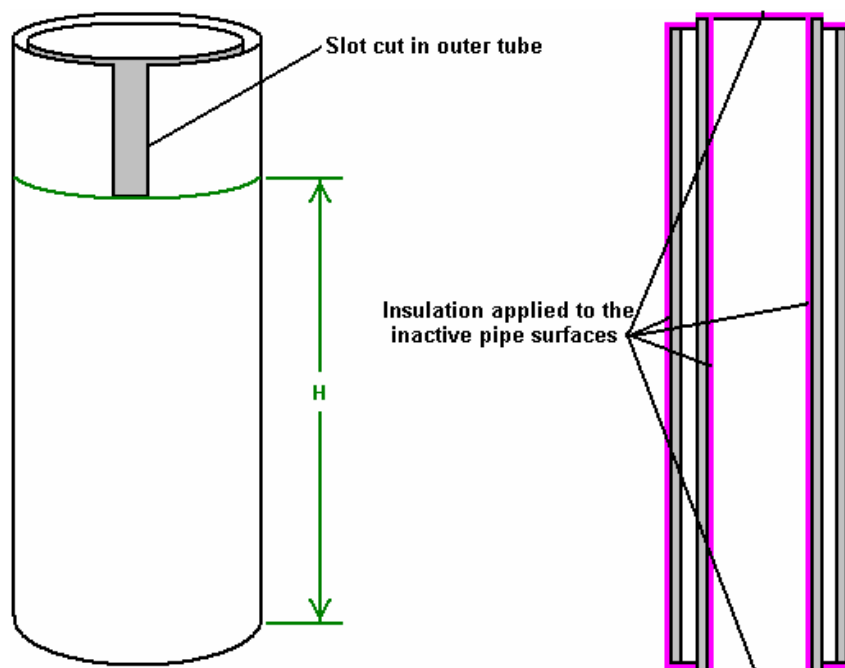

Some organ pipes are fine-tuned by cutting slots like this in the top of the pipe, to raise its pitch, which is its frequency of vibration. As they have a smaller diameter, the inner pipes in the Meyer cell will resonate at a higher frequency than the outer pipes. It therefore seems probable that the slots cut by Stan are to raise the resonant frequency of the larger pipes, to match the resonant frequency of the inner pipes. If you want to do that, hanging the inner tube up on a piece of thread and tapping it, will produce a sound at the resonant pitch of the pipe. Cutting a slot in one outer pipe, suspending it on a piece of thread and tapping it, will allow the pitch of the two pipes to be compared. When one outer pipe has been matched to your satisfaction, then a slot of exactly the same dimensions will bring the other outer pipes to the same resonant pitch. It has not been proved, but it has been suggested that only the part of the outer pipe which is below the slot, actually contributes to the resonant frequency of the pipe. That is the part marked as "H" in the diagram above. It is also suggested that the pipes will resonate at the same frequency if the area of the inside face of the outer pipe ("H" x the inner circumference) exactly matches the area of the outer surface of the inner pipe. It should be remembered that as all of the pipe pairs will be resonated with a single signal, that each pipe pair needs to resonate at the same frequency as all the other pipe pairs.

It is said that Stan ran his VolksWagen car for four years, using just the gas from four of these units which had pipe pairs 16-inches long. A very important part of the cell build is the conditioning of the electrode tubes, using tap water. Ravi in India suggests that this is done as follows:

1. Do not use any resistance on the negative side of the power supply when conditioning the pipes.
2. Start at 0.5 Amps on the signal generator and after 25 minutes, switch off for 30 minutes
3. Then apply 1.0 Amps for 20 minutes and then stop for 30 minutes.
4. Then apply 1.5 Amps for 15 minutes and then stop for 20 minutes.
5. Then apply 2.0 Amps for 10 minutes and afterwards stop for 20 minutes.
6. Go to 2.5 Amps for 5 minutes and stop for 15 minutes.
7. Go to 3.0 Amps for 120 to 150 seconds. You need to check if the cell is getting hot...if it is you need to reduce the time.

After the seven steps above, let the cell stand for at least an hour before you start all over again.

You will see hardly any gas generation in the early stages of this conditioning process, but a lot of brown muck will be generated. Initially, change the water after every cycle, but **do not** touch the tubes with bare hands. If the ends of the tubes need to have muck cleaned off them, then use a brush but do not touch the electrodes!! If the brown muck is left in the water during the next cycle, it causes the water to heat up and you need to avoid this.

Over a period of time, there is a reduction in the amount of the brown stuff produced and at some point, the pipes won't make any brown stuff at all. You will be getting very good gas generation by now. A whitish powdery coat of chromium oxide dielectric will have developed on the surfaces of the electrodes. Never touch the pipes with bare hands once this helpful coating has developed.

Important: Do the conditioning in a well-ventilated area, or alternatively, close the top of the cell and vent the gas out into the open. During this process, the cell is left on for quite some time, so even a very low rate of gas production can accumulate a serious amount of gas which would be a hazard if left to collect indoors.

Further Developments

When producing hydroxy gas from water, it is not possible to exceed the Faraday maximum unless additional energy is being drawn in from the surrounding environment. As this cell runs cold and has substantial gas output, there is every indication that when it is running, it is drawing in this extra energy.

This idea is supported by the fact that one of the key methods of tapping this extra energy is by producing a train of very sharply rising and sharply falling electrical pulses. This is exactly the objective of Dave's circuit, so it would not be too surprising if that effect were happening.

The additional energy being accessed is sometimes referred to as "cold" electricity, which has very different characteristics to normal conventional electricity. Where normal electrical losses cause local heating as a by-product, "cold" electricity has exactly the opposite effect, and where a normal electrical loss would take place, an extra inflow of useful "cold" energy enters the circuit from outside. This flow causes the temperature of the circuitry to drop, instead of increase, which is why it is called "cold" electricity.

This remarkable occurrence has the most unusual effect of actually reducing the amount of conventional power needed to drive the circuit, if the output load is increased. So, increasing the load powered by the circuit causes additional energy to flow in from the environment, powering the extra load and as well, helping to drive the original circuit. This seems very strange, but then, "cold" electricity operates in an entirely different way to our familiar

conventional electricity, and it has its own set of unfamiliar rules, which are generally the reverse of what we are used to.

To test his cell system further, Dave connected an extra load across the electrodes of his cell. As the inductors connected each side of the cell generate very high-value, sharp voltage spikes, Dave connected two large value capacitors (83,000 microfarad, 50-volt) across the cell as well. The load was a 10-watt light bulb which shines brightly, and interestingly, the current draw of the circuit goes down rather than up, in spite of the extra output power. The gas production rate appears undiminished.

This is the alteration to that part of the circuit which was used:

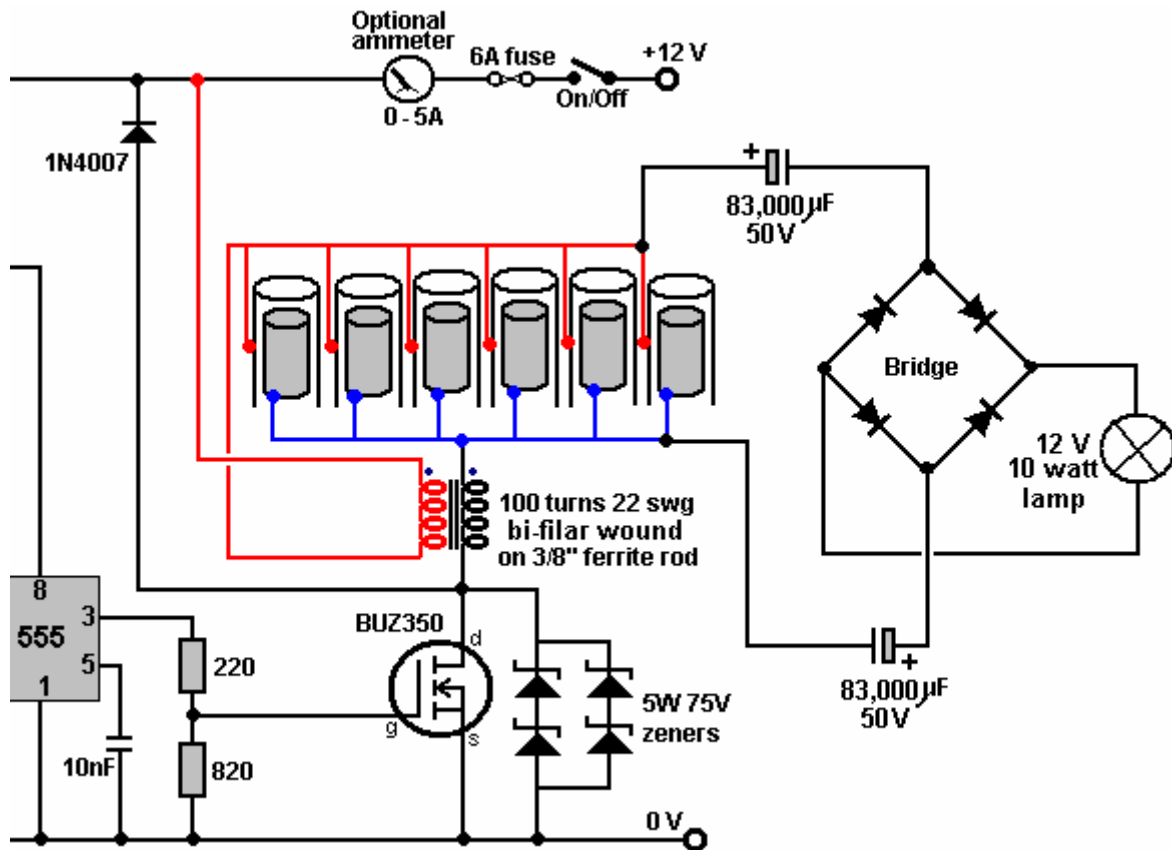

It has also been suggested that if a BUZ350 can't be obtained, then it would be advisable to protect the output FET against damage caused by accidental short-circuiting of wires, etc., by connecting what is effectively a 150-volt, 10 watt zener diode across it as shown in the above diagram. While this is not necessary for the correct operation of the circuit, it is helpful in cases where accidents occur during repeated testing and modification of the cell components.



Dr Scott Cramton's Cell Construction.

Dr. Cramton and his team of Laesa Research and Development scientists have been investigating and advancing this technology and they have reached an output of six litres per minute for an electrical input of 12 watts (1 amp at 12 volts). In addition, Dr. Cramton's cell has stable frequency operation and is being run on local

well water. The objective is to reduce the amount of diesel fuel needed to run a large capacity standard electrical generator.

The style of design is similar to Stan Meyer's original physical construction although the dimensions are slightly different. The cell body is transparent acrylic tube with end caps top and bottom. Inside the tube are nine pairs of pipes, electrically connected as three sets of three interspersed pipe pairs. These are driven by a three-phase pulsed supply based on a replication of Stan Meyer's original cell. It consists of a Delco Remy alternator driven by a 1.5 horsepower 220 volt AC motor. This arrangement is, as was Stan Meyer's, for demonstration purposes. In a working application, the alternator is driven by the engine being supplied with the hydroxy gas. The 120 degree phase separation is the critical component for maintaining the resonant frequency. It should be noted that the alternator must maintain a rate of 3,600 rpm while under load.

It needs to be stressed that Dr. Cramton's cell is very close in construction principles to Dave Lawton's cell and the quality of construction is very important indeed. The first and foremost point which can be easily missed is the absolutely essential tuning of all of the pipes to a single, common frequency. This is the equivalent of tuning a musical instrument and without that tuning, the essential resonant operation of the cell will not be achieved and the cell performance will not be anything like the results which Dr. Cramton and his team are getting.

Dr. Cramton is using 316L-grade stainless steel pipes 18 inches (450 mm) long. The outer pipes are 0.75 inches in diameter and the inner pipes 0.5 inches in diameter. This gives an inter-pipe gap of 1.2 mm. The first step is to get the pipes resonating together. First, the frequency of an inner pipe is measured. For this, a free internet frequency-analyzer program was downloaded and used with the audio card of a PC to give a measured display of the resonant frequency of each pipe. The download location is <http://www.softpedia.com/get/Multimedia/Audio/Other-AUDIO-Tools/Spectrum-Analyzer-pro-Live.shtml>

The method for doing this is very important and considerable care is needed for this. The quarter-inch stainless steel bolt is pressed into the inner pipe where it forms a tight push-fit. It is very important that the head of each nut is pressed in for **exactly** the same distance as this alters the resonant frequency of the inner pipe. The steel connecting strip is then bent into its Z shape and securely clamped to the bolt with a stainless steel nut. The assembly of pipe, steel strip, nut and bolt is then hung up on a thread and tapped gently with a piece of wood and its resonant frequency measured with the frequency analyzer program. The frequency is fed into the program using a microphone. All of the inner pipes are tuned to exactly the same frequency by a very slight alteration of the insertion length of the bolt head for any pipe with a resonant frequency which is slightly off the frequency of the other pipes in the set of nine inner pipes.

Next, the outer tubes are slotted to raise their resonant frequency to match that of the inner pipes. Their frequency is also measured by hanging them up and tapping them gently with a piece of wood. If the frequency needs additional raising, then the tube length is reduced by a quarter of an inch (6 mm) and the testing continued as before. Adjusting the width and length of the slot is the best method for adjusting the resonant frequency of the tube. A small file can be used to increase the slot dimensions. This procedure is time consuming and tedious but it is well worth the effort. The average finished length of the outer pipes is 17.5 inches (445 mm) and the slot dimensions 0.75 inch long and 0.5 inch wide (19 mm x 13 mm).

When setting the resonant frequency of the outer pipes, it is important to have the clips in place. These "hosepipe", "jubilee" or "Terry" clips are used to make electrical connections to the outer pipes as shown in the diagrams and they do have an effect on the resonance of the pipes, so fit them before any tuning is done. The pipe arrangement is shown here:

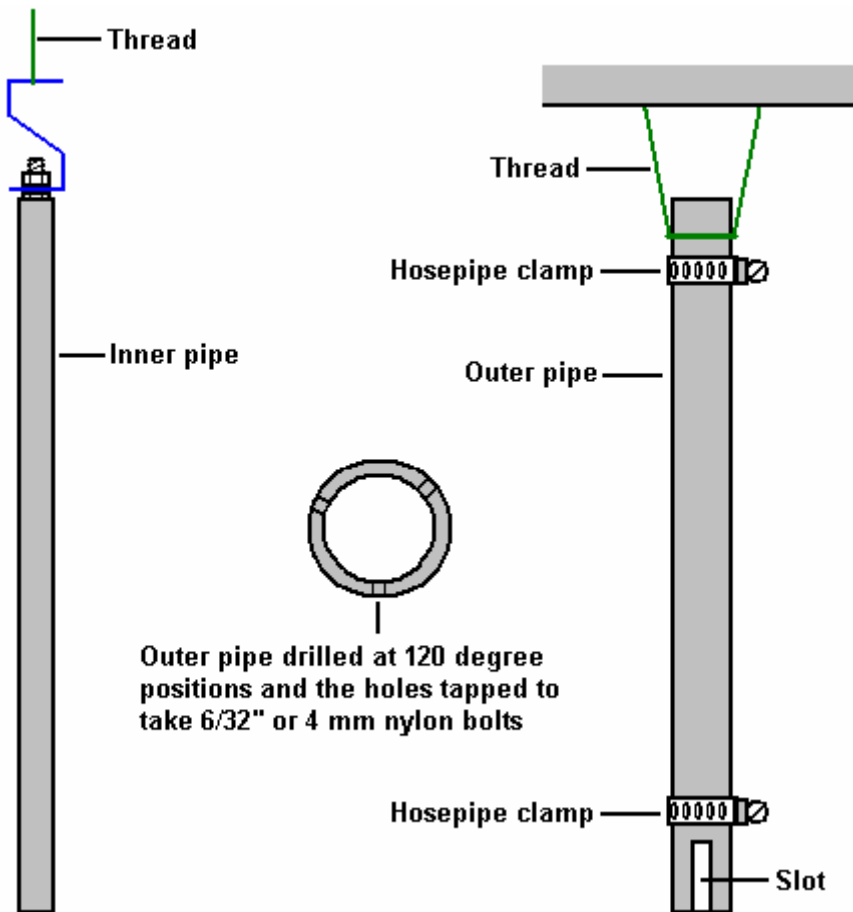

The outer pipes are drilled and tapped to take either a 6/32" nylon bolt available from Ace hardware stores in the USA, or alternatively, drilled and tapped to take a 4 mm nylon bolt. Three of these bolt holes are evenly spaced around the circumference of each end of all of the outer pipes.

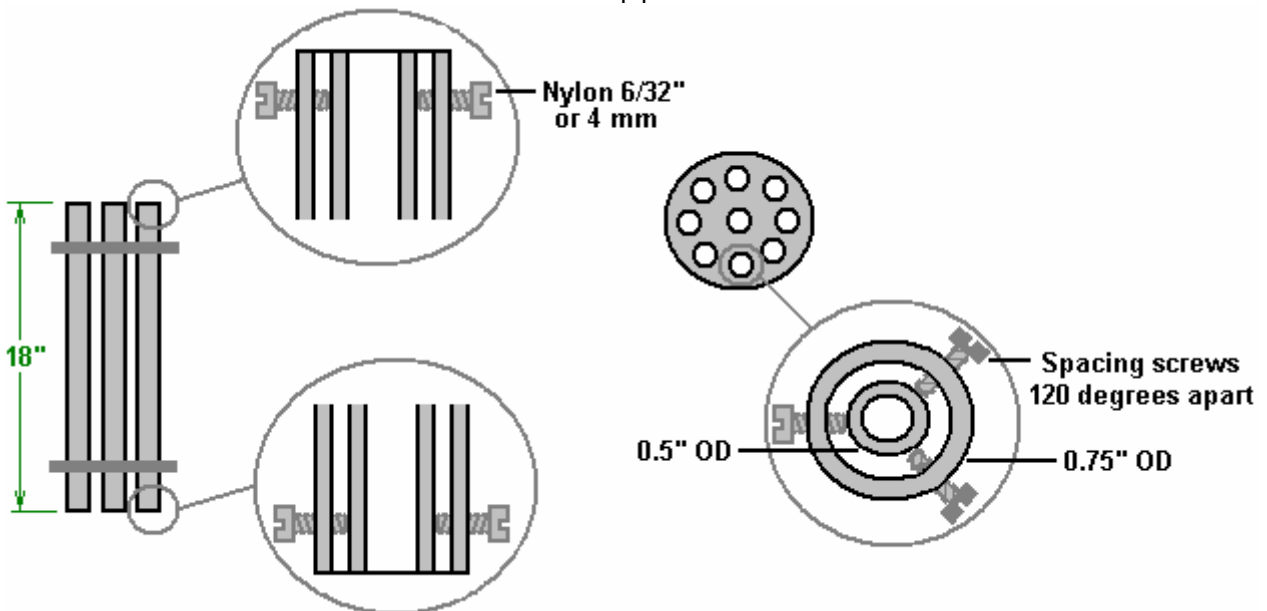

These nylon bolts are used to adjust and hold the inner pipe **gently** in the exact centre of the outer pipe. It is very important that these bolts are not over tightened as that would hinder the vibrations of the inner pipe. The bolts are adjusted so that a feeler gauge shows that there is exactly the same 1.2 mm gap all round, both top and bottom. The weight of the inner pipe is carried by a 3/4 inch (18 mm) wide strip of stainless steel bent into a Z-shape, and **none** of the weight is carried by the nylon bolts. Dr Cramton describes this Z-shaped steel strip as a

“spring” and stresses its importance in constructing a set of resonating pipe pairs. The arrangement is shown here:

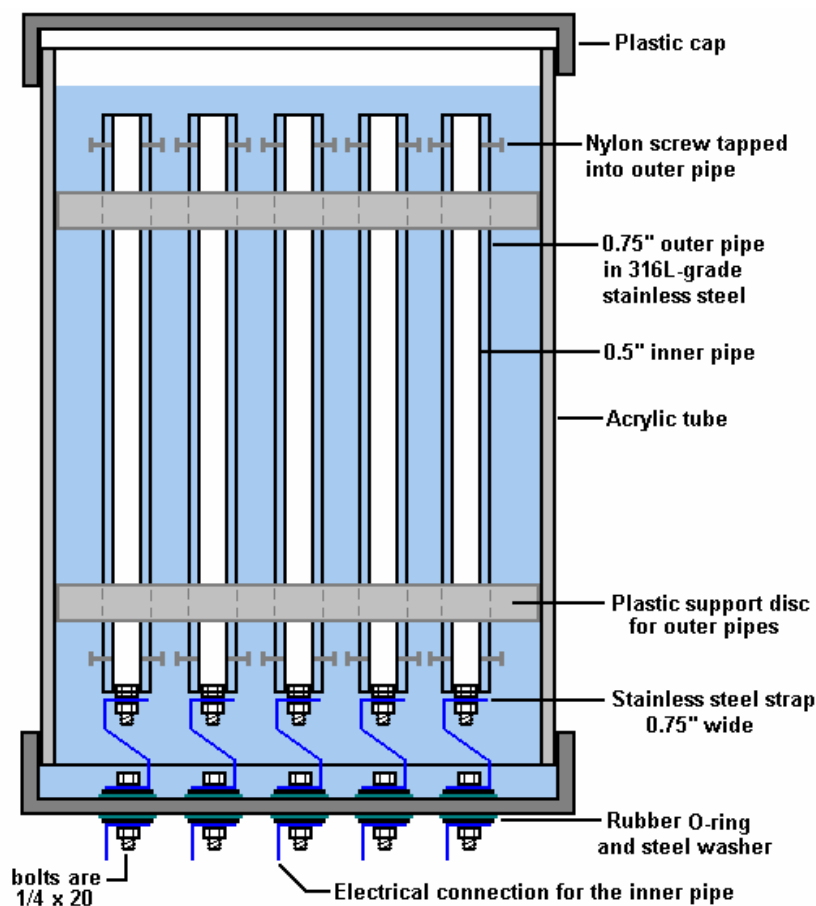

The supporting springy strip of steel is shown in blue in the above diagram as it also forms the electrical connection for the inner tubes. The outer tubes are held securely in position by two plastic discs which form a tight push-fit inside the 6" (150 mm) diameter acrylic tube which forms the body of the cell. The cell is sealed off with plastic caps (ideally, the upper one being screw threaded for easy maintenance) and the electrical connections are carried through the lower cap using 1/4" (6 mm) x 20 stainless steel bolts. The bolts are sealed using washers and rubber O-rings on both sides of the cap.

For clarity, the diagram above shows only the electrical connections for the inner pipes. The electrical connections for the outer pipes are shown in the following diagram. The connections are made at both the top and the bottom of each outer pipe by attaching a stainless steel hose clamp with a stainless steel bolt attached to each clamp. The wiring is then carried across inside the cell so that all six connection points (three at the top plus three at the bottom) for each set of three pipes are carried out through the base of the cell with just one bolt, again, sealed with washers and rubber O-rings. The nine pipe pairs are electrically connected in three sets of three, and each set is fed with a separate phase of a 3-phase waveform. This sets up an interaction through the water and produces a complex pulsing waveform with each set of pipes interacting with the other two sets. The sets are arranged so that the individual pipes of each set are interspersed with the pipes of the other two sets, making the sets overlap each other as shown in the next diagram. For clarity, the diagram does not show the electrical connections for the inner pipes and it omits the pipes of the other two groups of three, the water-level sensor, the gas take off pipe and the gas-pressure sensor.

At this time, Dr. Cramton is driving the pipe arrays with the circuit shown below. It uses an AC sinewave generated by a pulsed alternator. The current fed to the motor driving the alternator accounts for about 24 watts of power while the current drive to the alternator winding is just 12 watts. It should be realised that the alternator can easily drive many cells, probably without any increase in power required. Dr. Cramton is investigating methods of producing the same waveform without the need for an alternator and while that would be useful, it should be realised that a gas output of six litres per minute for a power input of only 36 watts is a very significant result. Others have shown that it is possible to power a 5.5 kilowatt electrical generator on hydroxy gas alone with a flow rate of this sort of magnitude, and obviously, the 36 watts can very easily be provided from that 5.5 kilowatt output.

It is absolutely essential that the pipe pairs are “conditioned” as there will be very little gas production until the white conditioning layer is built up on the active surfaces of the pipes. As has already been described, one

method is by powering the cell up for a few minutes, and then letting it rest unused for a time before repeating the process. Dr. Cramton emphasises that at least a hundred hours of conditioning will be needed before the gas output volume starts to rise, and it will be three months before the white conditioning layer reaches its full thickness and the gas production rate increases dramatically.

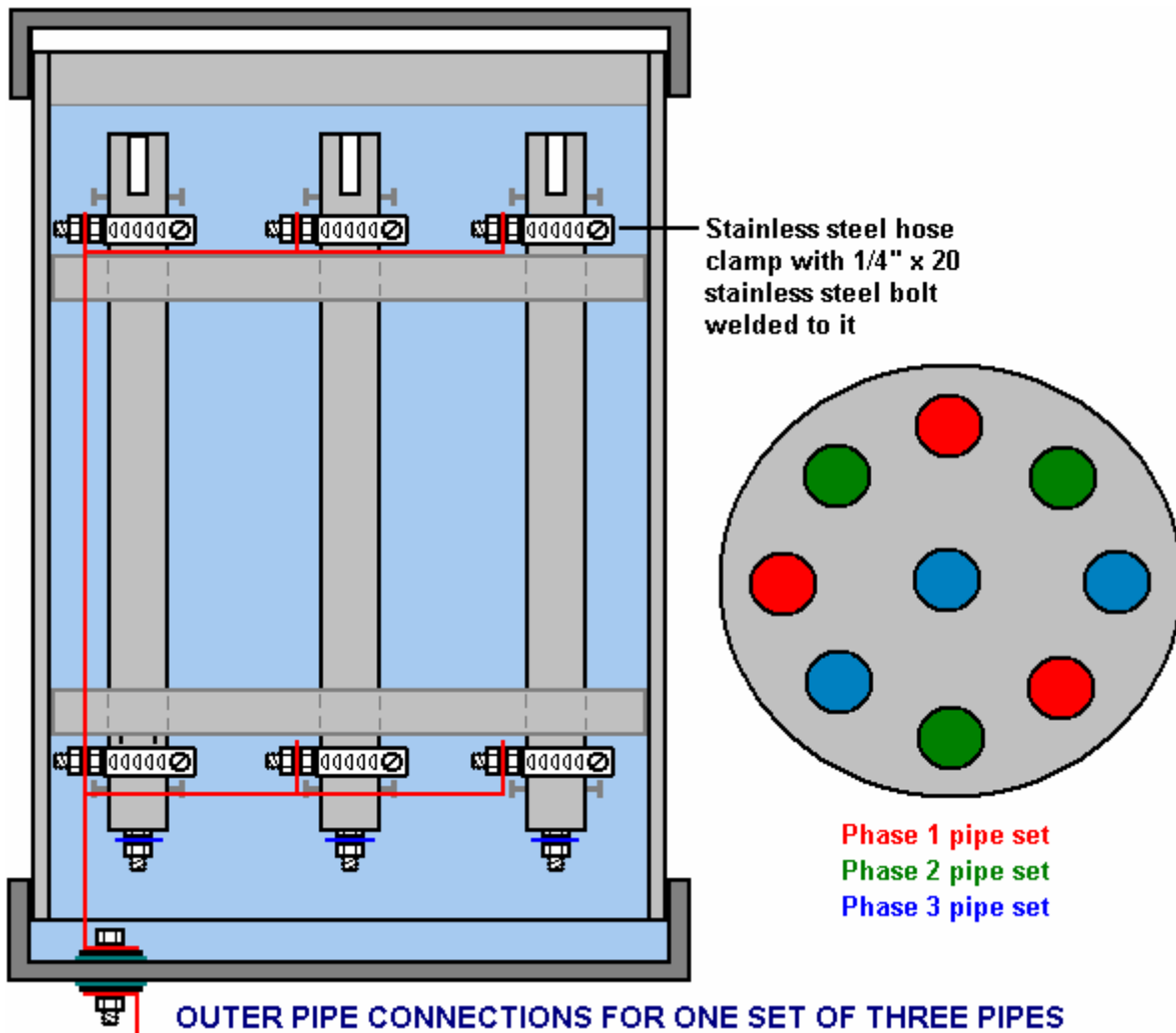

Dr Cramton stresses that it is the mechanical construction which will make the difference in the gas production rate. The inner and outer pipes must be tuned to a common frequency. It is vital that the pipe pairs must be conditioned, which can be done through repeated use over a period of time. A very important alternative to this long conditioning process is coating the whole of the pipe surfaces with the insulating material "Super Corona Dope" (<http://www.mgchemicals.com/products/4226.html>) as this gives immediate conditioning of the pipes. When a complete set of tuned tubes has been achieved, then the electronics must be built and tuned to the resonant frequency of the tube sets. Voltage builds up on the pipes from the repeated pulsing of the low voltage circuit and the action of the bi-filar wound coils each side of each pipe set and allowed by the insulation of the pipes. With Super Corona Dope this voltage has been measured at 1,480 volts but with the insulating layer from a local water supply, that voltage is around 1,340 volts.

It should be understood that the bi-filar wound coil (that is, wound with two strands of wire side by side) generates very sharply rising, very short voltage spikes, typically in excess of 1,000 volts in spite of the electrical supply being less than fourteen volts. The coils used by Dr Cramton are wound on ferrite rods, 300 mm (11.8") long and 10 mm (3/8") in diameter. As only 100 mm long rods were available, these were constructed by placing three inside a plastic tube. The coil winding is of enamelled copper wire and to allow sufficient current carrying capacity, that wire needs to be 22 swg (21 AWG) or a larger diameter, that is, with a lower gauge number such as 20 swg. These coils are wound to give an inductance of 6.3 mH on each of the two windings.

The circuit below is the one being used at this time. You will notice that an additional pole has been added to the Gating On/Off switch so that the timing components are switched out when the gating signal is turned off. This gives added protection for the Gating 555 chip in the circuit, preventing overheating when it is running but not being used. The frequency used with Dr. Cramton's cell is 4.73 kHz although this is not the optimum frequency for the cell. The alternator imposes a certain limitation on the highest possible frequency, but the frequency used

has been shown to be the most effective and it is a harmonic of the optimum frequency. This is a bit like pushing a child on a swing and only pushing every third or fourth swing, which works quite well.

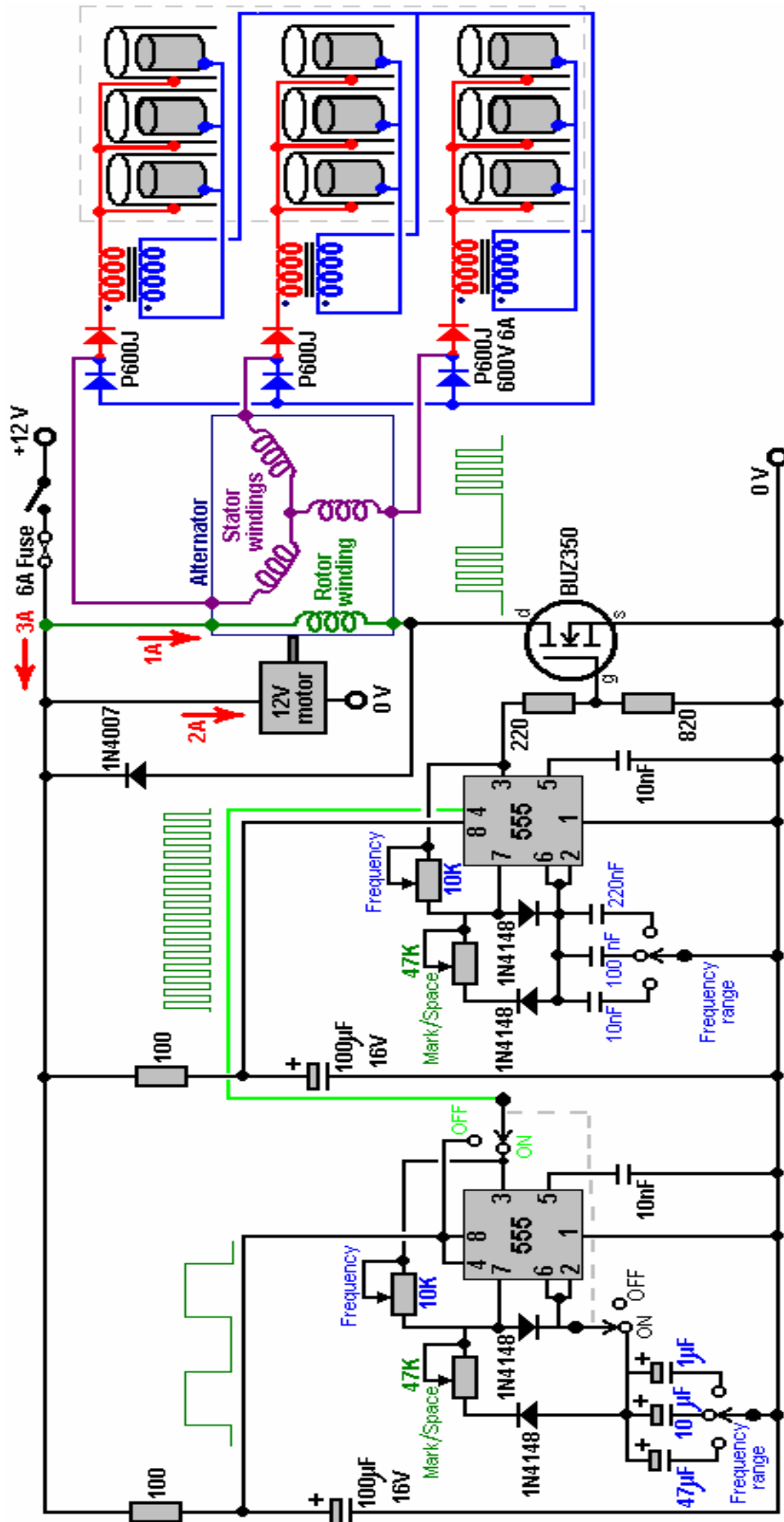

Dr. Cramton says: "I would like people to know that the scientific community is working on these projects and this technology is now a fact of science and not conjecture".

Dr Cramton has performed repeated performance tests on a 40 kilowatt diesel generator and the results were highly consistent, coming in within 1% each time on ten successive tests. Here is his graph of the results of this preliminary work:

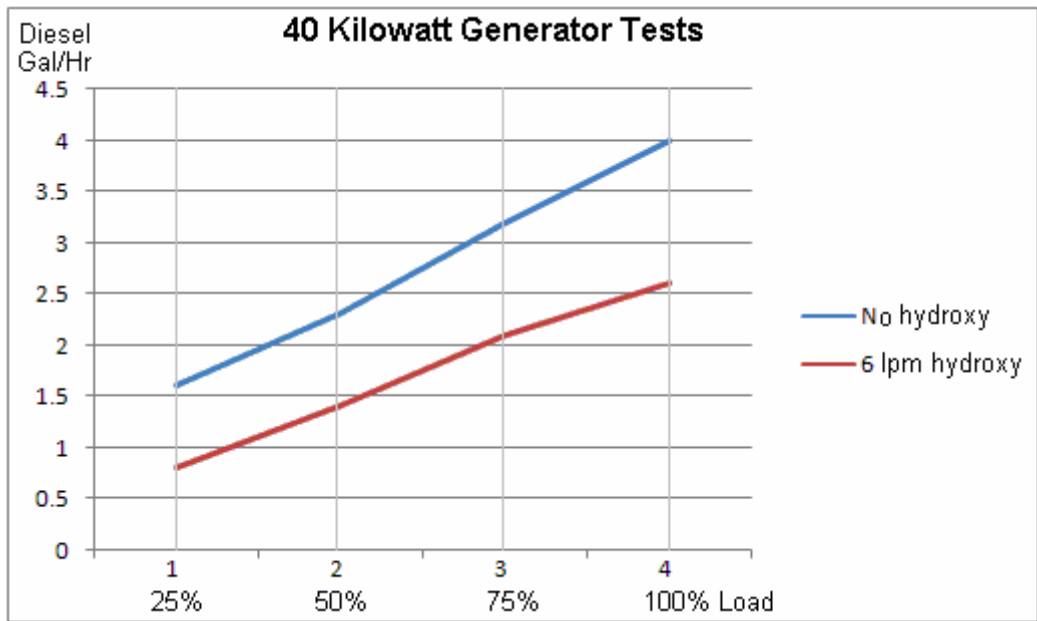

The gains at full 40 kW load are about 35%, representing a reduction of 1.4 gallons of diesel per hour. As the generator is part of the equipment of a major power supplier, it is likely that the number of generators will be manipulated in relation to the demand and so the continuous overall gain is likely to be about 33% even with such a low hydroxy input as 6 lpm. The investigation and development is continuing.

Bob Boyce's High-Gain Toroidal System.

Bob Boyce has recently released a different method for water-splitting using his flat-plate electrolyser-style construction and pulsed with just twelve volts as in the above water-splitter designs. Bob's circuit is:

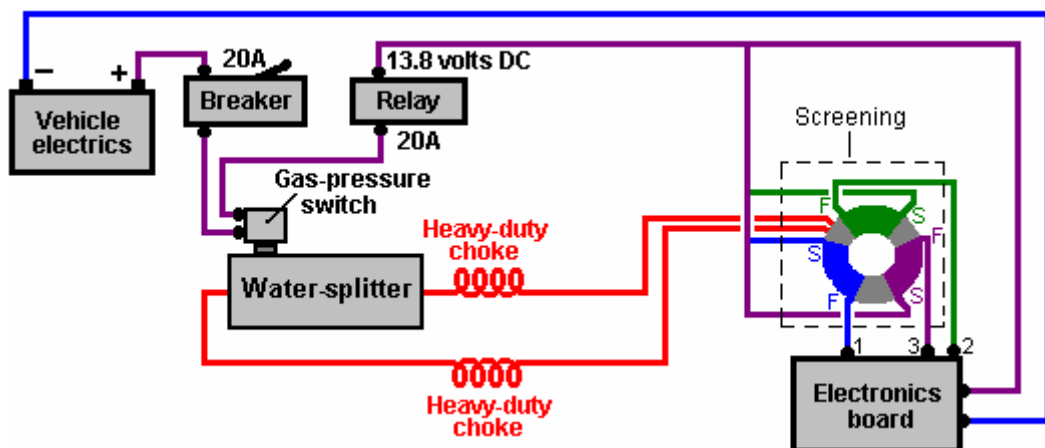

Here, the electronics board produces three separate, tuneable, very sharp square waveforms as described in the D9.pdf document mentioned earlier. These three waveforms are integrated into a single complex waveform when each is fed into a separate high-precision, high-specification winding on an iron-dust toroidal transformer core. This signal is stepped up to a higher voltage in the secondary coil of the transformer and then applied to the electrode plates via a choke coil on each side of the unit in exactly the same way as in the previous designs.

Resonance.

Water-splitters only operate properly if are held on their resonant frequency. Stan Meyer has a patent on his electronics system which would locate, lock on to and maintain the electronic pulsing at the resonant frequency of his cell. Unfortunately, Stan's patent just gives broad outlines for the methods used.

The John Bedini battery-charging pulse circuits have been very successfully applied to water-splitter cells. Here, the cell itself is part of the frequency control of the oscillator circuit and the arrangement might look like this:

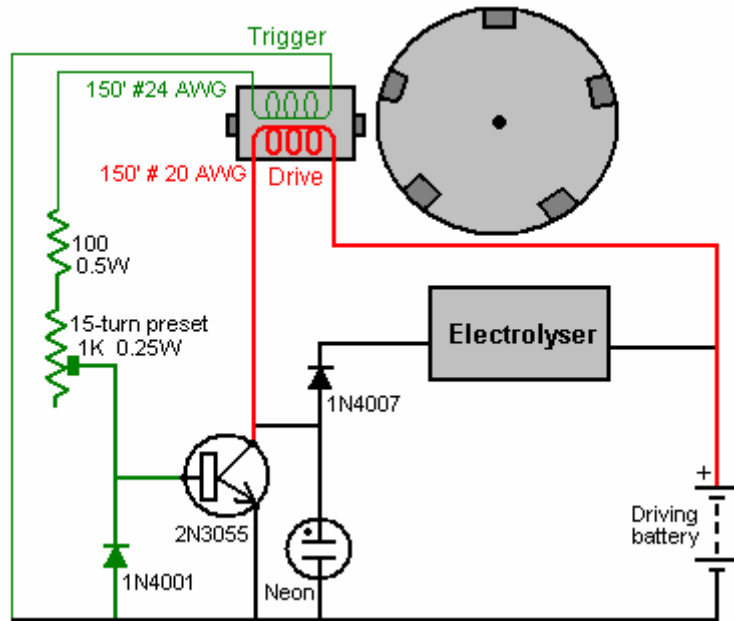

This idea is advocated on a YouTube video put up by a user whose ID is "TheGuru2You" where this arrangement is suggested:

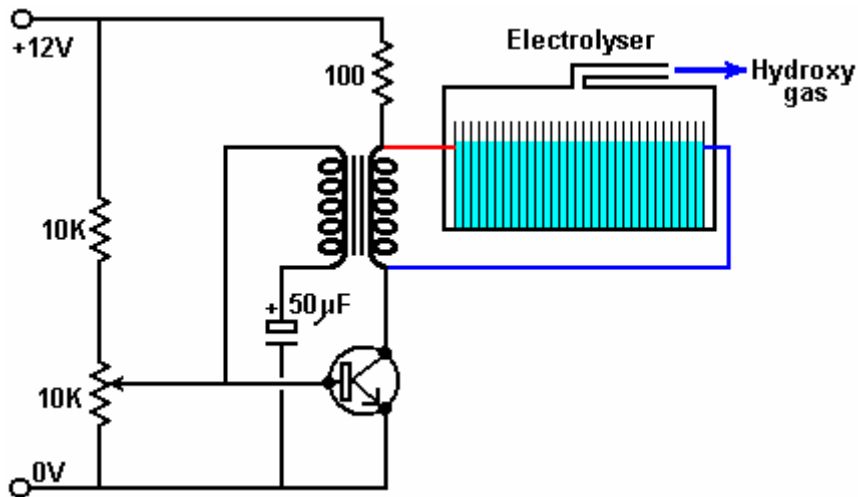

TheGuru2You states that he has built this circuit using a capacitor instead of the water-splitter and he says that he can confirm that it is self-powering, something which conventional science says is impossible (unless perhaps, if the circuit is picking up radiated power through the wiring of the circuit). Once a twelve volt supply is connected briefly to input terminals, the transistor switches on powering the transformer which feeds repeating pulses to the base of the transistor, sustaining the oscillations even when the twelve volt supply is removed. The rate of oscillation is governed by the resonant frequency of the water-splitter unit. Consequently, as the resonant frequency of the cell alters because bubbles form, the pressure changes, the temperature changes, or whatever, the circuit automatically tracks and maintains that optimum frequency.

Dave Lawton's Auto-Tune Circuit.

Dave Lawton uses a different method as he has designed and built a Phase-Lock Loop ("PLL") circuit which does the same thing that Stan Meyer's automatic circuit did. This is Dave's circuit:

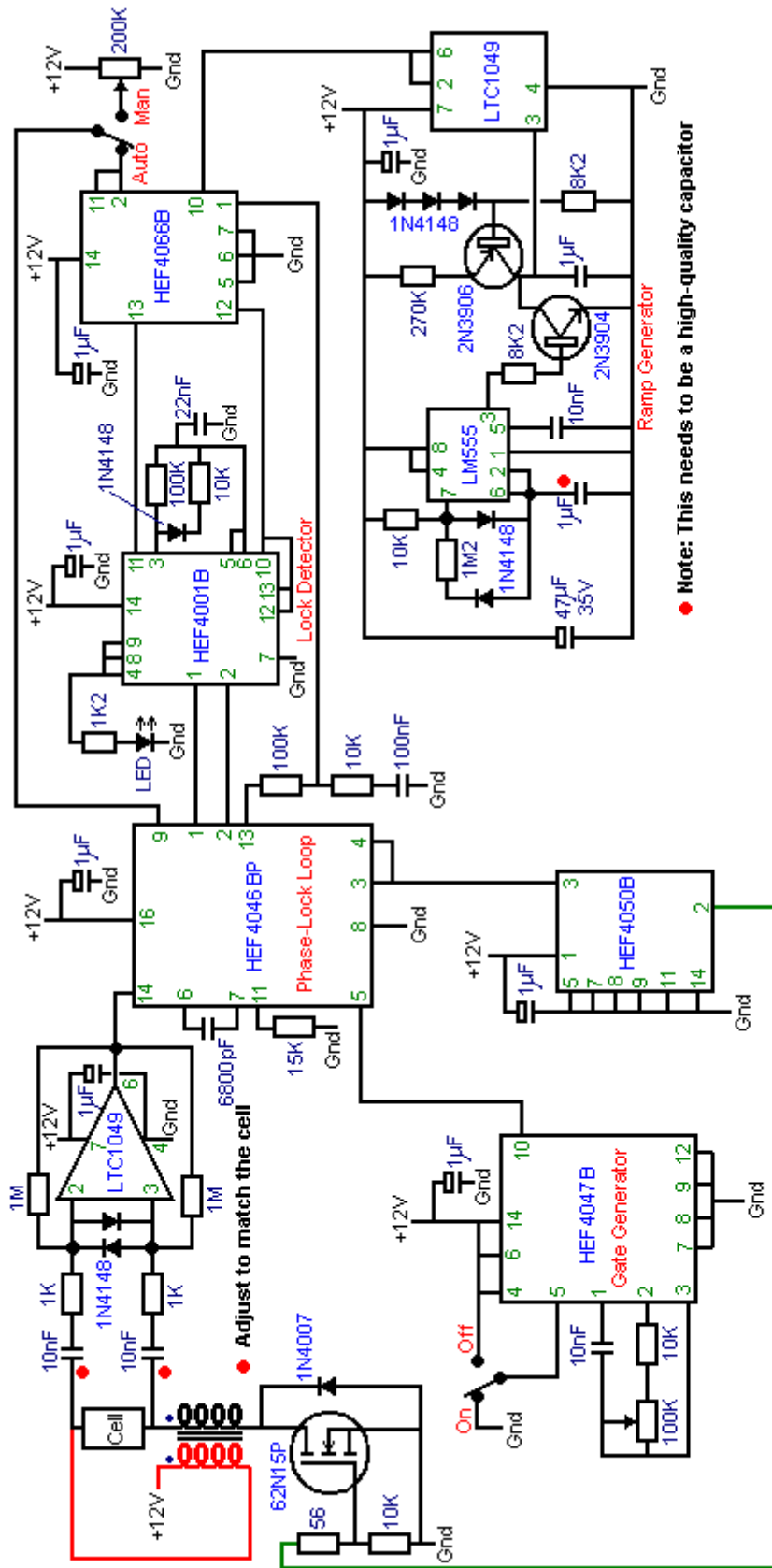

Capacitors are tantalum 35V. Resistors are carbon film 5% 0.33W. Variable resistors are presets (RadioSpares 154-2072 and 154-2094)
 Radiospares Part Numbers: LTC1049: 545-5607, HEF4046BP: 306-645, HEF4001B: 333-3303, HEF4068B: 333-1470, 2N3904: 294-312, 2N3906: 294-328, 62N15P: 194-316, 1N4148: 446-8551, 1N4007: 348-5397.

This circuit has been used very successfully by a number of people. One experimenter had the circuit built by a friend as he is not very confident with building electronic circuits. The construction looks like this:



The two air-core coils are wound separately rather than bi-filar wound, and some experimentation with different types will be undertaken to see the effect on overall gas production. This circuit is shown in the following video, driving a 2.6 inch long pair of electrodes with a 2 mm gap between them, sitting in a test cell. The electrodes have seams and are made of an unknown quality of stainless steel and can be seen at the top of the photograph above. The video: <http://youtu.be/XMizRAYdGwA> shows considerable gas production with almost no current draw and the cell staying completely cool.

Running Electrical Generators on Water Alone.

In the UK, three men managed to run a generator on water alone, using just simple things which are within the scope of the average handyman in his workshop. They bought a standard petrol-driven electrical generator off eBay and managed to run it without using any petrol. They used a hydroxy gas flow which they measured at just 3 lpm and they test loaded the 5.5 kilowatt generator with 4 kilowatts of equipment. Afterwards they abandoned the generator and moved on to a much bigger engine as their plans are to sell electricity to the local power company. They said: *the equipment was put together by my associate, who supplied the water/electrolyte (not a standard electrolyte, 0.4% by volume). It was a 5 kW petrol generator (about 300cc). We attached a Chevrolet alternator which constantly charges a 12-volt 55 Amp-Hour battery, which in turn powers six HHO tubes, each of which draws 6 watts, for a total of 30 watts. The outputs of these electrolyzers are connected in series and they feed the gas into a low-pressure butane gas "camping" tank which has an 18 psi pressure release valve. This tank feeds the air intake of the generator which is adjustable with a choke. We loaded the 30-amp socket of the generator with various drills, heaters etc. working, for more than four hours. The maximum load which we tried was 4 kilowatts, being a bar heater, a kettle and two drills. The tubes are heavy-duty plastic (for 80 psi pressure). Inside are 4 tubes of stainless steel (3 positive and 1 negative). Each tube created 1 litre of gas every two minutes which is a total of 3 litres per minute. They eventually become warm to the touch, but they do not get hot.*

They have no plans to ever sell adapted generators and so they have no objection to the sharing of the following information. Here is how they made their eBay generator operate without petrol:

Running an Electrical Generator without Fossil Fuel



In Broad Outline

In order to achieve this objective, very much like Stan Meyer, we need to feed the engine three things:

1. Air - this is fed in as normal through the existing air filter.
2. Hydroxy gas - how to make this has already been explained in considerable detail.
3. A mist of very small water droplets, sometimes called "cold water fog".

Also, we need to make two adjustments to the engine:

1. The spark timing needs to be retarded by about eleven degrees.
2. If there is a "waste" spark, then that needs to be eliminated.

To summarise then, a good deal of work needs to be done to achieve this effect:

1. An electrolyser needs to be built or bought, although the required gas production rate is not particularly high.
2. A generator of cold water fog needs to be made or bought.
3. Pipes need to be installed to carry these two items into the engine.
4. The engine timing needs to be retarded.
5. Any waste spark needs to be suppressed.
6. Water tanks are needed for the cold water fog and to keep the electrolyser topped up.
7. Ideally, some form of automatic water refill for these water tanks should be provided so that the generator can run for long periods unattended.

If we omit the electrical safety equipment which has already been explained in detail, and omit the hydroxy gas safety equipment which has already been explained in detail, and skip the automated water supply details and the starting battery, then, a generalised sketch of the overall arrangement looks like this:

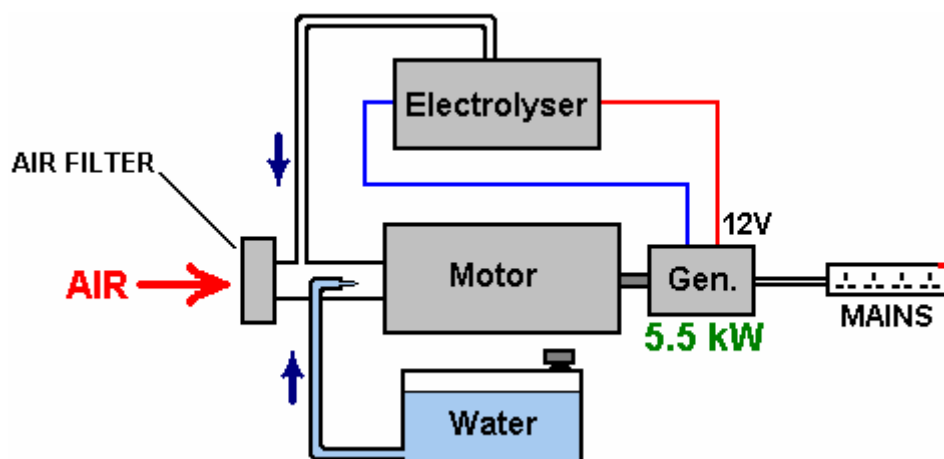

Here, they have opted to feed the hydroxy gas into the air system after the air filter (a thing which we normally avoid as it is not helpful for the hydroxy gas production efficiency, but the first step is to reproduce their successful method exactly before seeing if it can be improved further). Also fed into this same area is the cold water fog which is comprised of a very large number of very tiny droplets. The air enters this area as normal, through the existing air filter. This gives us the three necessary components for running the generator engine without using any fossil fuel.

Creating the cold water fog

There are three different ways to generate the spray of very fine water droplets which are a key feature of the success of this way of running the engine. One way is to use a Venturi tube, which, while it sounds like an impressive device, is actually very simple in construction:

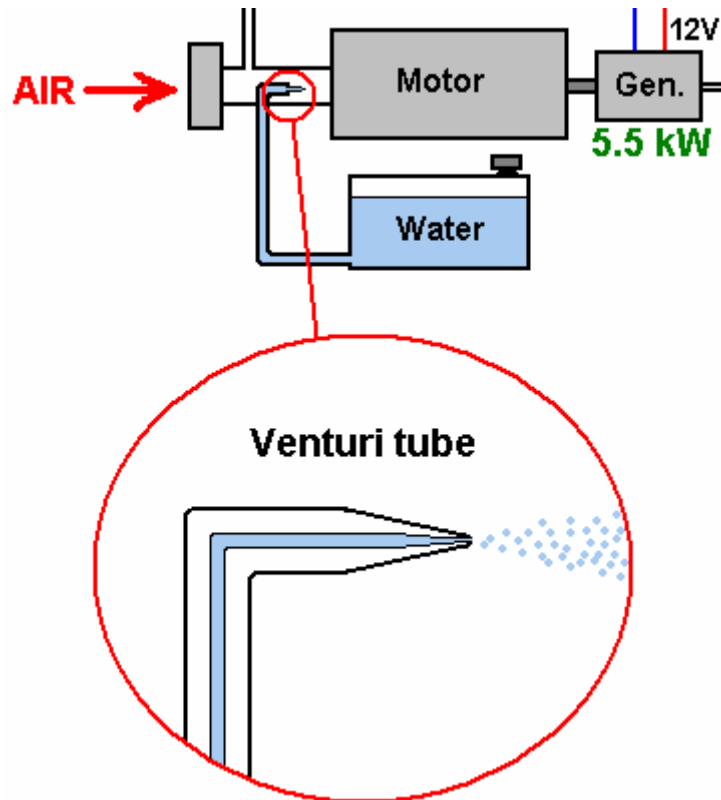

It is just a pipe which tapers to a point and which has a very small nozzle. As the engine draws in the air/hydroxy mix on it's intake stroke, the mixture rushes past the nozzle of the Venturi tube. This creates an area of lower pressure outside the nozzle and causes water to exit through the nozzle in a spray of very fine droplets. Some perfume spray bottles use this method as it is both cheap and effective.

An alternative method of making the cold water fog is to use one or more "pond foggers". These are small ultrasonic devices which are maintained at the optimum operating depth in the water by a float. They produce large amounts of cold water fog which can be fed into the engine like this:

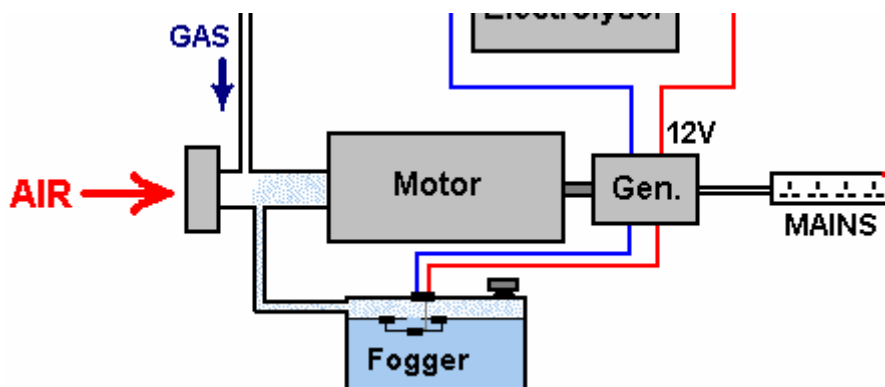

A third method is to use a small carburettor of the type used with model aircraft. This does the same job as a regular engine carburettor, feeding a spray of tiny water droplets into the engine air intake. The physical arrangement of this option depends on the construction of the air filter of the generator being modified. You will notice that the people in the UK who did this, used a small gas tank with an eighteen pounds per square inch pressure release valve. This is not possible with the highest quality of HHO gas as it cannot be compressed that much. However, with a lower grade of HHO which has some water vapour mixed in with it, it is possible to have a gas reservoir with that sort of pressure in it. In this case, except possibly for starting, their gas production rate is probably not high enough to allow much raised pressure inside the tank. Obviously, the gas-pressure switch on the electrolyser and the one on the gas storage tank will have similar operational pressures.

Some Safety Features

Up to this point, the electrolyser has been shown in bare outline. In practice, it is essential that some safety features are incorporated as shown here:

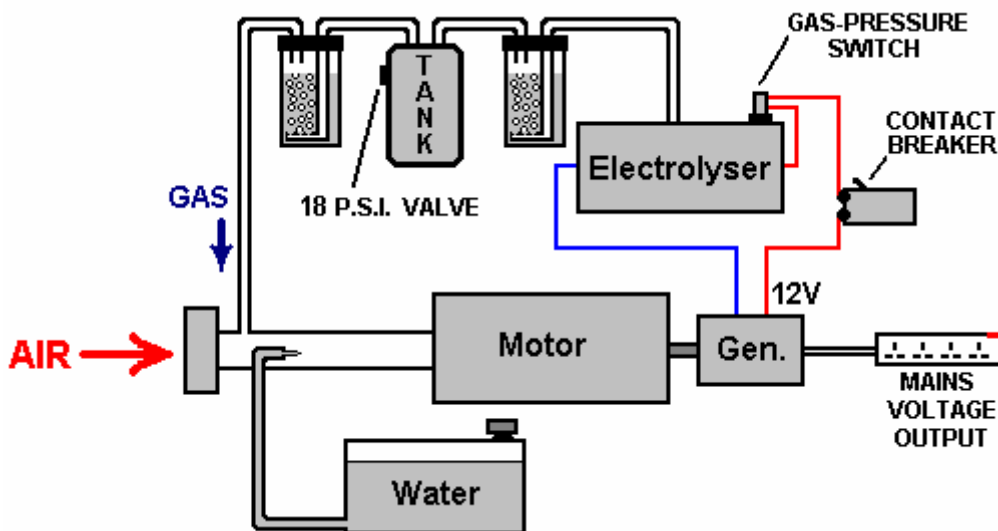

These safety devices should be familiar to you by now as they have already been explained earlier in this document.

The Reason for Changing the Timing

The fuels used with most internal combustion engines are either petrol (gasoline) or diesel. If you are not interested in chemistry, then you are probably not aware of the structure of these fuels. These fuels are called "hydrocarbons" because they are composed of hydrogen and carbon. Carbon has four bonds and so a carbon atom can link to four other atoms to form a molecule. Petrol is a long chain molecule with anything from seven to nine carbon atoms in a chain:

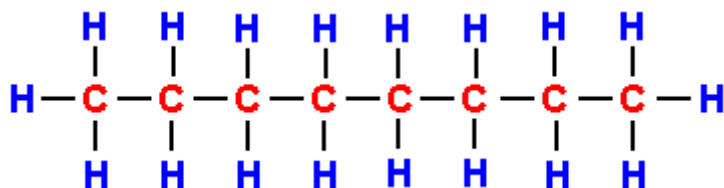

Diesel has the same structure but with eleven to eighteen carbon atoms in a chain. In a petrol engine, a fine spray of petrol is fed into each cylinder during the intake stroke. Ideally, the fuel should be in vapour form but this is not popular with the oil companies because doing that can give vehicle performances in the 100 to 300 mpg range and that would cut the profits from oil sales.

The petrol in the cylinder is compressed during the compression stroke and that reduces its volume and raises its temperature substantially. The air/fuel mix is then hit with a powerful spark and that provides enough energy to start a chemical reaction between the fuel and the air. Because the hydrocarbon chain is such a large molecule, it takes a moment for that chain to break up before the individual atoms combine with the oxygen in the air. The main engine power is produced by the hydrogen atoms combining with oxygen, as that reaction produces a large

amount of heat. The carbon atoms are not particularly helpful, forming carbon deposits inside the engine, not to mention some carbon monoxide (CO) and some carbon dioxide (CO₂) as well.

The key factor here is the slight delay between the spark and the combustion of the fuel. The combustion needs to happen a few degrees after Top Dead Centre when the piston is about to start its downward movement in the power stroke. Because of the delay caused by the hydrocarbon chain breaking down, the spark occurs a few degrees **before** Top Dead Centre:

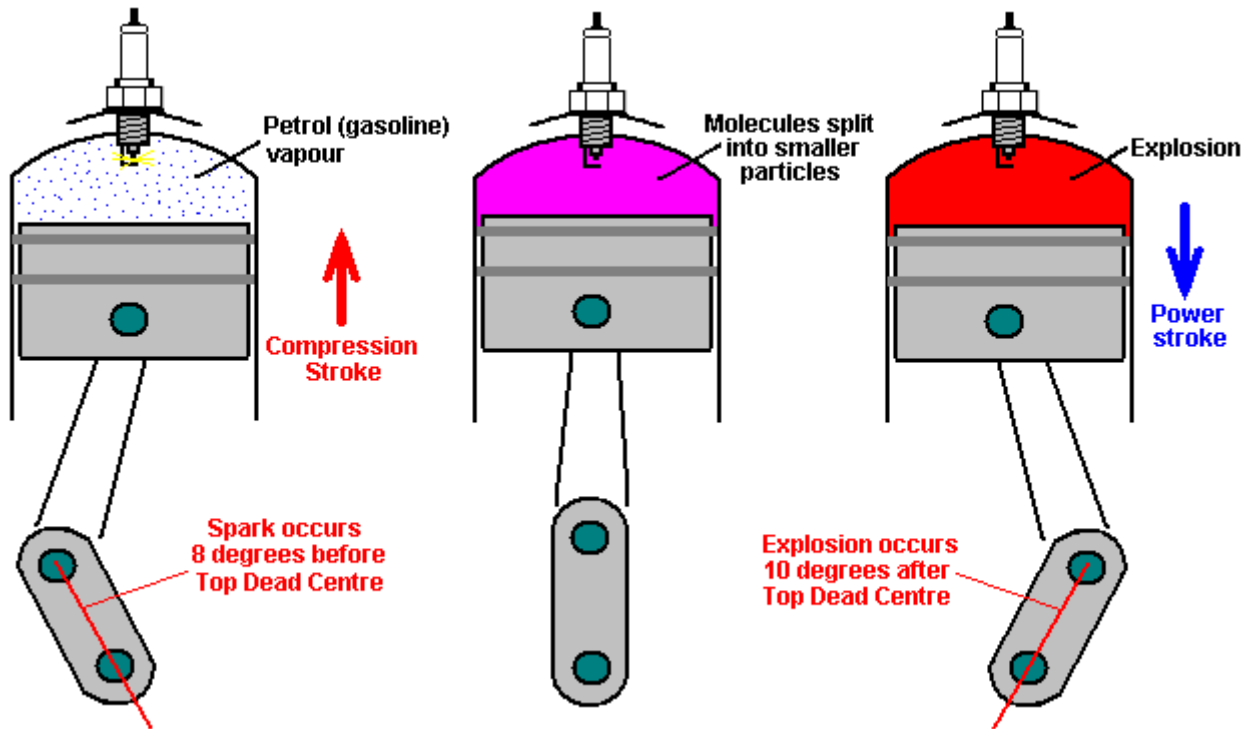

If you were to replace the petrol vapour with hydroxy gas, then there would be a major problem. This is because hydroxy gas has very small molecule sizes which do not need any kind of breaking down and which burn instantly with explosive force. The result would be an explosion which occurs far too soon and which opposes the movement of the rising piston as shown here:

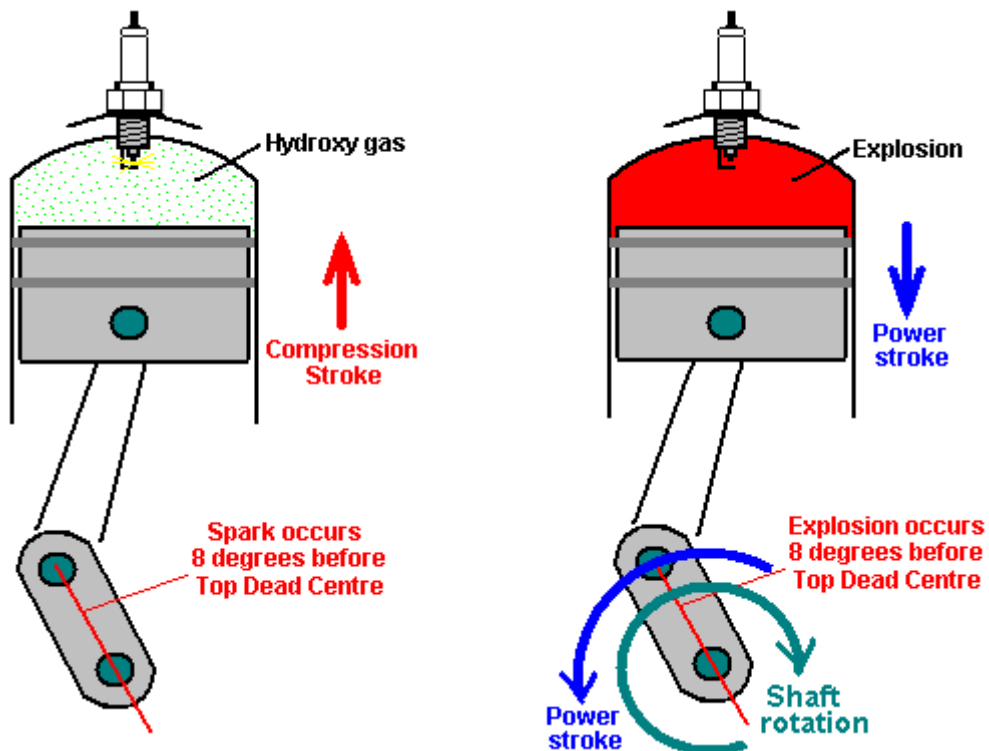

The forces imposed on the piston's connecting rod would be so high that it would be quite liable to break and cause additional engine damage.

In the case of our electrical generator, we will not be feeding it a mix of air and hydroxy gas, but instead, a mix of air, hydroxy gas and cold water fog. This delays the combustion of the hydroxy gas by a small amount, but it is still important to have the spark occur after Top Dead Centre, so the ignition of the generator needs to be retarded by eleven degrees.

Engine design varies considerably in ways which are not obvious to a quick glance at the engine. The timing of the valves is a big factor here. In the smallest and cheapest engines, the engine design is simplified by not having the spark timing taken off the cam-shaft. Instead, production costs are cut by taking the spark timing off the output shaft. This produces a spark on every revolution of the engine. But, if it is a four-stroke engine, the spark should only occur on the power stroke which is every second revolution of the output shaft. If the fuel is petrol, then this does not matter as the extra spark will occur near the end of the exhaust stroke when only burnt gasses are present in the cylinder.

Some people are concerned when they think of hydroxy gas burning and producing water inside the engine. They think of hydrogen embrittlement and rusting. However, because of the nature of the hydrocarbon fuel already being used, the engine runs primarily on hydrogen anyway and it always has produced water. The water is in the form of very hot vapour or steam and the engine heat dries it out when the engine is stopped. Hydrogen embrittlement does not occur as a result of using a hydroxy gas booster.

Anyway, if we were to delay the spark until after Top Dead Centre as we must, then the situation is quite different as the waste spark will also be delayed by the same amount. With most engines, at this point in time the exhaust valve will have closed and the intake valve opened. Our very flammable gas mix will be being fed into the engine on it's intake stroke. This means that our gas supply system is openly connected to the cylinder through the open intake valve, and so, the waste spark would ignite our gas supply system (as far as the bubbler which would smother the flashback). The situation is shown here:

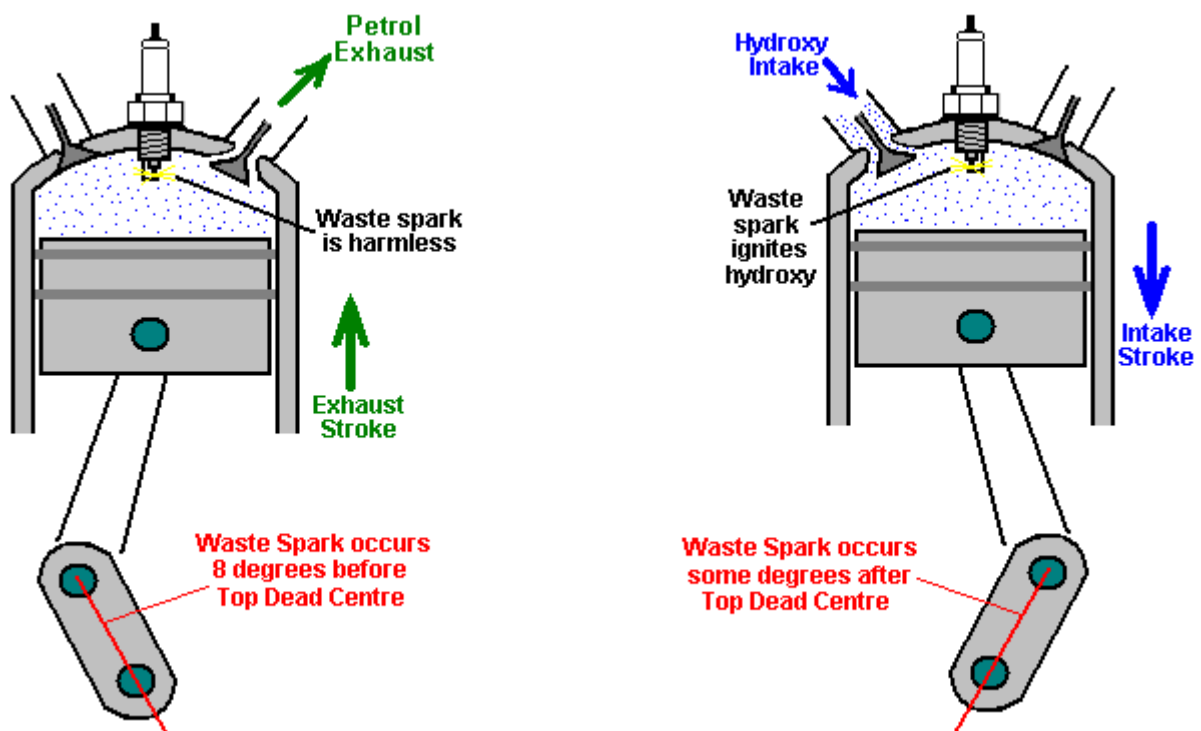

we definitely do not want that to happen, so it is very important that we suppress that additional "waste" spark. So, this leaves us with two engine adjustments: timing delay and waste spark elimination. There are various ways in which these can be done and as each engine design is different, it is difficult to cover every possibility. However, there is a technique which can be used with many engines and which deals with both issues at the same time.

Most engines of this type are four-stroke engines with intake and exhaust valves, perhaps something like this:

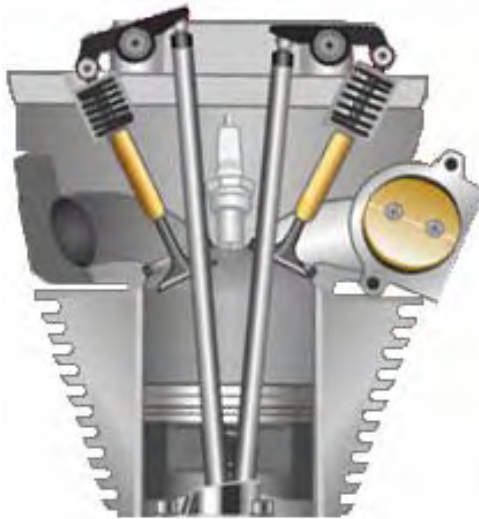

The intake valve (shown on the right in this illustration) is pushed down by a cam shaft, compressing the spring and opening the inlet port. The exact arrangement will be different from one engine design to the next. What is fixed is the movement of the valve itself and that movement only takes place every second revolution. There are various ways of using those movement to eliminate the waste spark and retard the timing. If a switch were mounted so that it opens when the intake valve opens and closes when the intake valve closes, then the switch closure shows when the piston starts upwards on its compression stroke and a simple electronic circuit can then give an adjustable delay before firing the coil which produces the spark. This, of course, involves disconnecting the original electrical circuit so that no waste spark is generated. The current flowing through the switch contacts can be arranged to be so low that there will be no sparking at the contacts when the circuit is broken again. The switch positioning might be like this:



An alternative is to attach a strong permanent magnet to the rocker arm, using epoxy resin, and then position a solid state "Hall-effect" sensor so that it triggers the delay before the spark is generated.

If the engine did not have a waste spark, then in theory, the timing mechanism of the engine could be used to retard the spark. However, in practice, the timing mechanism is almost never capable of retarding the spark to the position that is needed for running without fossil fuel, and so, some kind of delay circuit will be needed anyway.

The sort of delay circuit needed is called a "monostable" as it has only one stable state. A basic circuit of that type is:

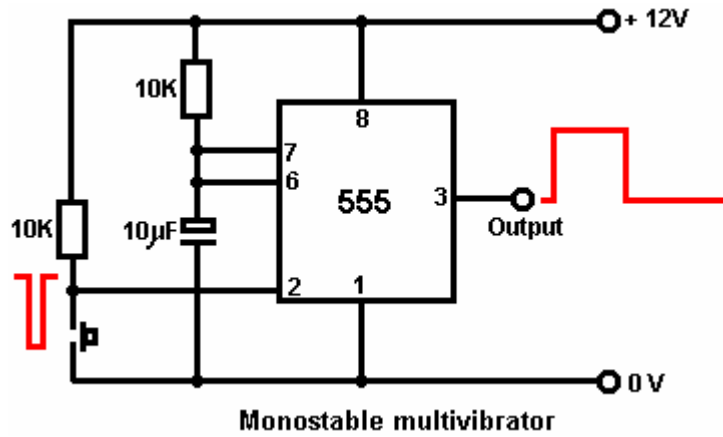

If you are not at all familiar with electronic circuits, then take a look at the beginner's electronics tutorial found in the Chapter12.pdf document on the <http://www.free-energy-info.co.uk> website as that explains how circuitry works and how to build any simple circuit from scratch. We can use two of these circuits, the first to give the adjustable delay and the second to give a brief pulse to the ignition circuit to generate the spark:

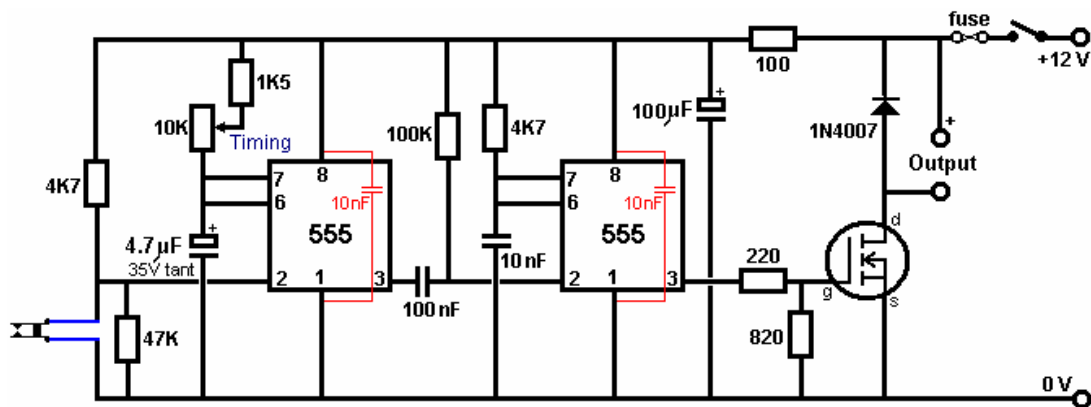

Making the hydroxy gas

When the generator is running, we have a ready supply of electrical energy, coming from a piece of equipment which has been specifically designed to supply large quantities of electricity for any required application. We are not dealing with the spare capacity of some low-grade alternator in a car, but we have substantial electrical power available.

Having said that, the electrolyzers described at the start of this document are efficient and it is unlikely that an excessive amount of power would be needed when using one of those designs. Another convenient factor is that this is a stationary application, so the size and weight of the electrolyser is not at all important, and this gives us further flexibility in our choices of dimensions.

As this is an application where it is highly likely that the electrolyser will be operated for long periods unattended, an automated water supply system should be provided. The main details of such a system have already been covered, but what has not yet been dealt with is the switching for the water pump. The water pump itself can be an ordinary windscreen-washer pump, and we need some form of switch which operates on the electrolyte level inside the electrolyser. It is sufficient to sense the level in just one of the cells inside the electrolyser as the water usage will be pretty much the same in every cell. If you make the electrolyser in a suitable size or shape, then a simple off-the-shelf miniature float switch can be used. If you prefer, an electronic level sensor can be operated, using two bolts through the side of the electrolyser as the level sensor. A suitable circuit for this simple switching task could be:

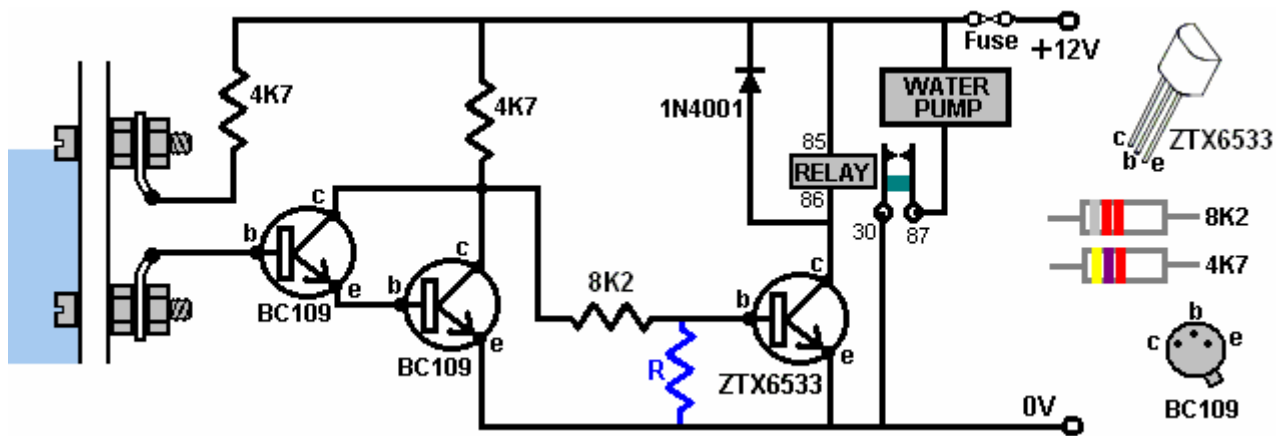

When the electrolyte level inside the electrolyser is in contact with the upper bolt head, the circuit is switched off and the water pump is powered down. The electrolyte has a low resistance to current flow, and so it connects the 4.7K resistor through to the base of the BC109 Darlington pair (as described in Chapter 12). This keeps the two transistors switched fully on which keeps the 8.2K resistor connection well below the 0.7 volts needed to switch the ZTX6533 transistor on. If you are concerned about the ZTX6533 transistor being partially on, then resistor "R" could be added, although the prototype did not need one. The value would be about 2K. When the electrolyte level falls below the upper bolt head, the first two transistors switch off, and the ZTX6533 transistor is then powered fully on by the 4.7K resistor and the 8.2K resistor in series, providing the 150 mA needed for the relay to be switched fully on. The circuit draws about 5 mA in it's standby state. The numbers on the relay symbol correspond to the numbers on a typical automotive 12 volt relay. Using two BC109 transistors as the front end allows this circuit to be used with tap water if you wish. However, the water-level control for the water supply to the pond fogger or Venturi tube misting device does not need any form of fancy mechanism. The standard ball-cock valve mechanism which is used with toilets is quite adequate, especially if a floating pond fogger is being used as it maintains its own optimum depth below the surface and so the overall depth is not in any way critical provided, of course, there is sufficient depth for the fogger to float correctly.

Starting:

When left for any length of time, the gas pressure inside the electrolyser will drop because the nature of the hydroxy gas alters. This means that there will not be sufficient hydroxy gas available to start the engine and no more gas will be generated until the engine drives the generator. So, to deal with this situation, a lead-acid car battery is included so that it can be switched in to replace the generator for a brief period before the engine is started. That inclusion gives this overall arrangement:

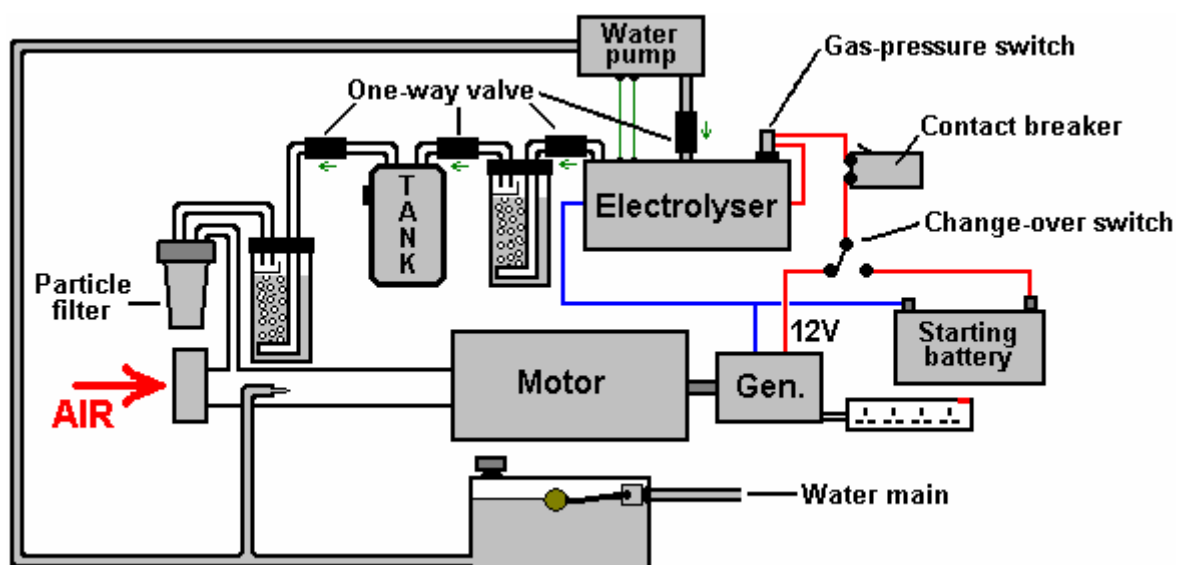

This arrangement is perfectly capable of running a standard generator without the use of any fossil fuel. It should be noted that while no fossil fuel needs to be bought to run this generator system, the electrical output is far from

free and is actually quite expensive as there is the purchase cost of the generator, the electrolyser and the minor additional equipment. Also, generators have a definite working life and so will need to be refurbished or replaced.

It might also be remarked that if a generator of this type is going to be used in an urban environment, then the addition of sound-reducing baffles and housing would be very desirable. At this point in time I am aware of nine different electric generators which have been adapted to run on water. At least four of these are from different manufacturers. The method of altering the timing and dealing with the waste spark is different from one adaption to the next. One user has altered the spark timing of his generator to after Top Dead Centre by rotating the timing disc to a position not envisaged by the manufacturer. The timing disc is held in place by a locking ("key") bar which fits into a channel cut in the shaft of the engine, matching it to a similar channel cut in the disc. The alteration was achieved by cutting a new channel in the shaft, allowing the timing disc to be positioned further around the shaft, producing the required timing delay. This arrangement also makes the waste spark ineffective and so it can be ignored. While this method requires the cutting of a slot, it does away with the need for any electronics and it is a very simple solution.

If you feel that the construction of a suitable electrolyser would be a problem or that the amount of electric current needed to operate it would be excessive, let me show you the actual figures involved:

Michael Faraday was an exceptional and highly respected researcher who investigated the electric current needed to convert water into hydrogen gas and oxygen gas by electrolysis. His results are accepted by pretty much every scientist everywhere. While he expressed the results of his work in terms which would be meaningless to the average person, his result is that an electrical input of 2.34 watts produces one litre of hydroxy gas in one hour.

In practical terms, that means that a current of 0.195 amps at 12 volts will produce 1 litre of hydroxy gas in one hour. In passing, only a nearly discharged lead-acid battery would have a voltage of 12 volts as the fully charged state is 12.85 volts and a vehicle alternator produces about 14 volts in order to charge the battery.

It is easier then, to compare the gas output of electrolyzers directly to the figures produced by Faraday as shown here, based on a gas output of 15 litres per minute which is 900 litres per hour:

Faraday: 900 litres in one hour, takes 2,106 watts or 100% Faraday
Boyce: 900 litres in one hour, takes 998 watts or 211% Faraday without pulsing
Boyce: 900 litres in one hour, takes 180 watts or 1,170% Faraday with pulsing
Cramton: 900 litres in one hour, takes 90 watts or 2,340% Faraday

Much of this is not very important as it has been demonstrated that a gas production rate of around 3 lpm (180 lph) is sufficient to run a generator which produces 5,500 watts. Let us assume that the measured figure is 100% wrong and that it takes 360 lph of hydroxy gas, plus cold water fog, plus air, to run the generator, then:

Faraday would need 843 watts
Boyce would need 400 watts without pulsing
Boyce would need 72 watts with pulsing
Cramton would need 36 watts

None of these figures are important for running a generator because with an electrolyser efficiency of only 50% Faraday still leaves a massive generator excess of nearly 4 kilowatts on a 5.5 kilowatt generator. The gain is in running a generator as an internal combustion steam engine and not in the great efficiency of the electrolyser. It is distinctly possible that the pessimistic figures shown above are twice what is actually needed, but who cares? - the facts speak for themselves, with several people scattered around the world, already running generators on water. Many different generator designs have been adapted, typically, by modifying the flywheel, filling in the keyway and cutting another one to give a spark 2 degrees after TDC. Experience has shown that the 6.6 kVA Honda V-twin petrol motor generator and the Vanguard V-twin work very well long-term when adapted to run on water only.

Wear and Tear Issues

A man who lives in Alaska is very experienced in the use of renewable energy sources and unconventional fuel systems. His experiences are likely to be helpful for anyone who intends to use an electrical generator, whether running on water or on a fossil fuel. He recalls the experiences of a friend:

He decided to live off-the-grid because it was going to cost him \$20,000 to get connected to the grid and as his house was not that large, he decided to go the alternative route. We designed a system which would use a 4 kW inverter and have an 8 kW Briggs & Stratton generator with a 13 kW surge capacity, for back up. The system has 6 solar panels and a 24 volt battery bank with 400 amp capacity. Having long summer days here in Alaska, the solar panels have more than enough capacity for charging the battery bank on sunny days. However, but

when the day is overcast or when it is winter when there are only six hours of sunlight, the battery bank does not get charged fully. At these times, the generator is used to top up the battery bank.

American generators normally have either two or four 120-volt outputs each rated at 15 amps, plus one 240-volt output rated at 33 amps. If one of the two 120-volt outputs is used to charge the battery bank, then you get left with just the other 120-volt output for any other power needs during the time when the battery bank is being charged. This is not a satisfactory arrangement as operating with one field at maximum power and the other one lightly loaded or unused, causes a field imbalance in the generator, engine crank imbalance and ring or regulator failure within six months. It also causes noisy running and excessive fuel consumption.

Run in this way, providing a 60-amp charge rate, the generator ran hard and loud for two to two and a half hours per day, and running it was costing \$350 per month for gasoline. The generator failed after four months.

In order to balance the loading on the replacement generator, a 15 kVA step-down transformer costing less than \$1000 was purchased so that the 240-volt output could be used to drive 120-volt equipment. A transformer to be used for this needs to have a power-handling capacity which is greater than the surge capacity of the generator. A major advantage is that the generator current is halved for any given level of equipment current drawn because the equipment is running at only half of the generator voltage.

Using this transformer made a massive difference, giving a balanced output and providing a 90-amp charging rate for the battery bank as well as having ample power to run other household equipment when the battery bank was being charged. The result was a charge time of just one hour twenty minutes per day, with the generator running quietly and smoothly. The fuel consumption also dropped to just \$70 per month which is just one fifth of what it was, covering the cost of the transformer in under four months. This generator has been running now for two years without any problems at all.

The Step-by-Step Conversion of a Generator

Selwyn Harris of Australia has kindly agreed to share detailed information on how he performs the conversion of a standard electrical generator to enable it to run on water alone. The generator which he uses as an example for this tutorial is a GX4000i generator:



The supplier is AGR Machinery which is an Australian company on eBay which buys up stock from collapsed companies and resells the equipment. The supplier says: GX4000i portable type generators have smoother output power, comparable to public utility sources. Ideal for powering medium loads such as:

- Power tools - Both Single & 3 Phase
- Game consoles, Digital Cameras
- Laptops, Camcorders
- Lighting and Microwave Ovens
- Drills, Grinders
- Resistive Load Kitchen Appliances (i.e. Coffee Maker, Toaster)
- Emergency Home Back up power where 240v power is required

Also, these units are significantly quieter than others due to refined engine technology

Features:

- Commercial Grade Engine: 196 cc 4-stroke, 7 horsepower, overhead camshaft, T.D.I. ignition
- Maximum output 4.0 kVA at 240 or 415V AC (Rated output: 2.7 kilowatts)
- Quality Heavy-Duty Construction
- AVR (Auto Voltage Regulator)
- Three 240V and one 415V Protected Outlets
- 100% Pure Copper Core
- Gearless direct drive
- Robust Square frame Design
- Easy – Recoil Start
- Oil capacity: 0.7 litres
- Powder Coated Finish
- Light and Compact for easy manoeuvrability (38.5 Kg)
- Noise level: 69 dB

The first step of the conversion is to remove the fuel tank which is held in place with four bolts:



This allows access to the carburettor which is then removed as it will not be used:



The next step is to construct a pressure-release valve mechanism which will protect the equipment from damage in the unlikely event of a major, sudden rise in pressure caused by the unwanted ignition of the HHO gas mix used to power the generator. For this, parts are purchased from the local hardware store. The brass fittings are a 12mm barrel, a 12mm female T-fitting and a 12mm to 9mm hose reducer as shown here:



The PVC plastic fittings are a 1/2" to 1-1/4" reducer and a 1-1/4" End Cap, along with the roller ball from an old-fashioned mouse and a relatively weak compression spring to hold the ball in place during normal operation where the gas pressure is low:



These components are then assembled to produce the pressure-release valve:



The inside of the flash-arrestor looks like this:

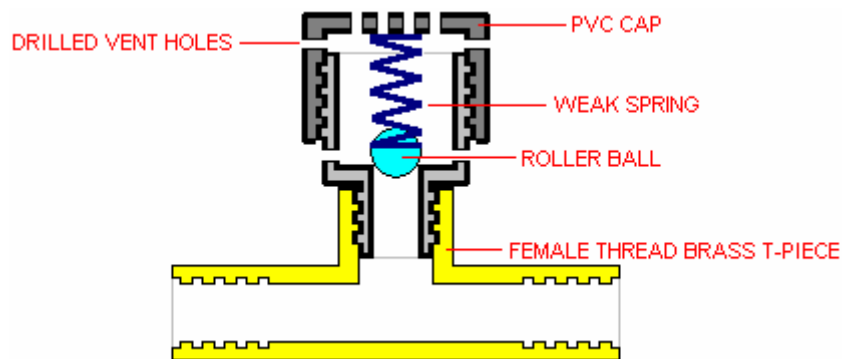

The ball is held in place by the spring allowing the HHO to flow past it, but if a sudden increase in pressure should occur, then the ball is forced upwards, opening a path to the many holes drilled in the plastic fittings:

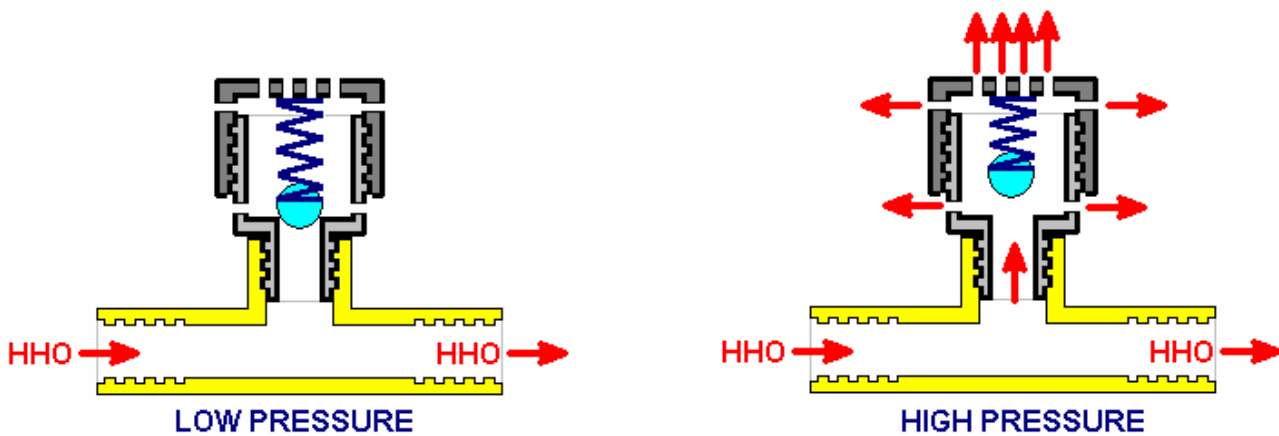

When the gas pressure drops again, the spring pushes the roller ball down to seal off the pressure-release holes.

However, Selwyn adds an additional spring-loaded valve to the arrangement. This one is there in case the electrolyser fails to produce a sufficient volume of gas in the event of a sudden increase in demand. This valve is

marked as a “vacuum-relief” valve although, strictly speaking, it deals with reduced pressure rather than an actual vacuum. The arrangement is shown below. Please take note of the fact that Selwyn uses the Hogg style of electrolyser and that design has a bubbler built into it, so if you are using some other design of electrolyser, please be very sure to use at least one bubbler between the electrolyser and the engine, in spite of the fact that there is very little chance of the engine mis-firing and igniting the HHO gas in the electrolyser. For an engine of this size, an electrolyser which produces 4.5 or 5 lpm of HHO should be adequate.

The addition of cold water mist through a Venturi tube as shown, both lowers the engine temperature and increases the engine power as the mist converts instantly to flash-steam when the HHO gas ignites, raising the pressure inside the cylinder and boosting the power output.

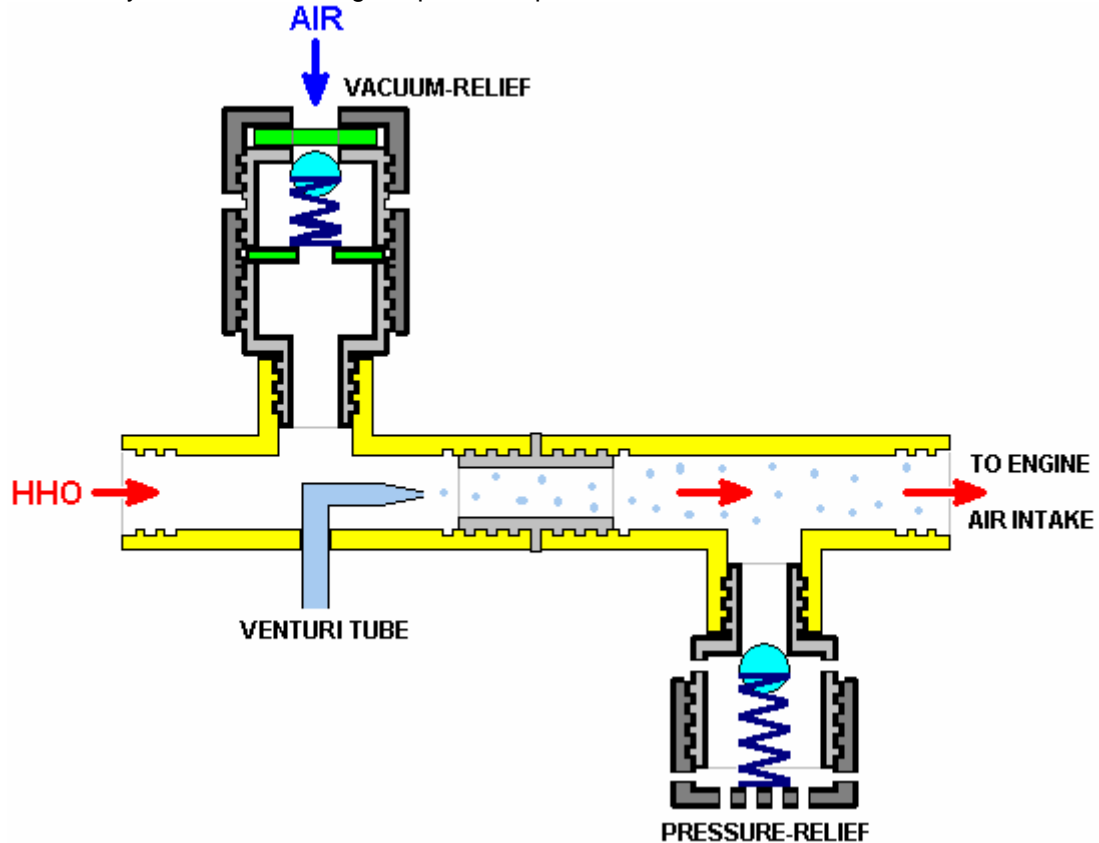

Next, a piece of ¼" (6 mm) thick aluminium plate is cut and shaped to the size of the carburettor gasket which is not a symmetrical item. This is done by tracing the gasket and transferring it on to the aluminium plate, drilling the holes and then cutting out the outline shape. The edges are then filed to create a nice fit on the engine port.



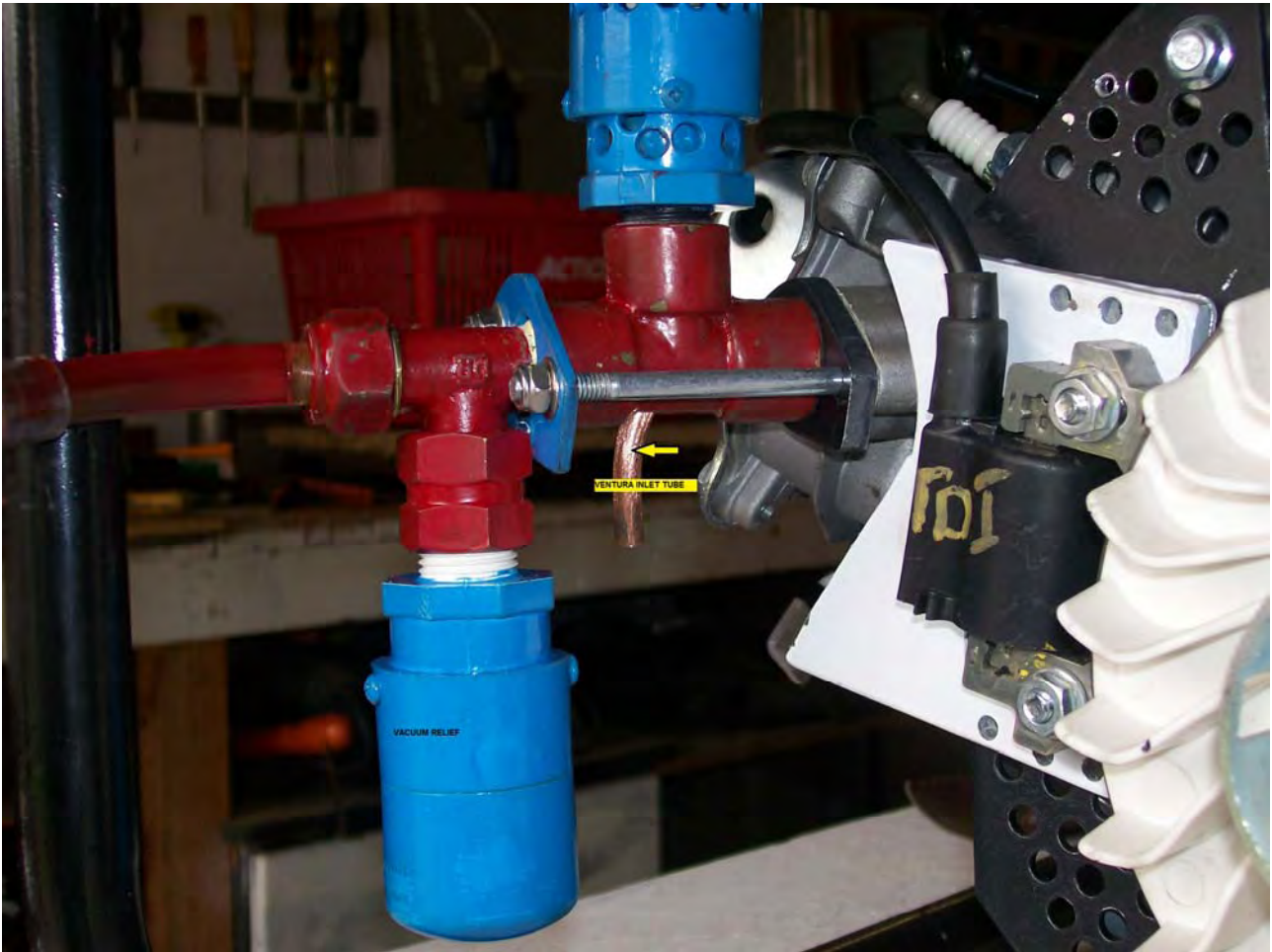

The pipes, backing plate, pressure-relief, vacuum-relief, gaskets, nuts and bolts are then assembled as shown above. Most of the pressure-relief valve components shown in the photograph have been painted, which happens to conceal the different materials being used.

At this point an electrolyser of any design which can produce at least 4.5 litres of HHO gas mix per minute is connected to the intake. The electrolyser most often used by Selwyn is the Hogg design disclosed by him earlier in this chapter.

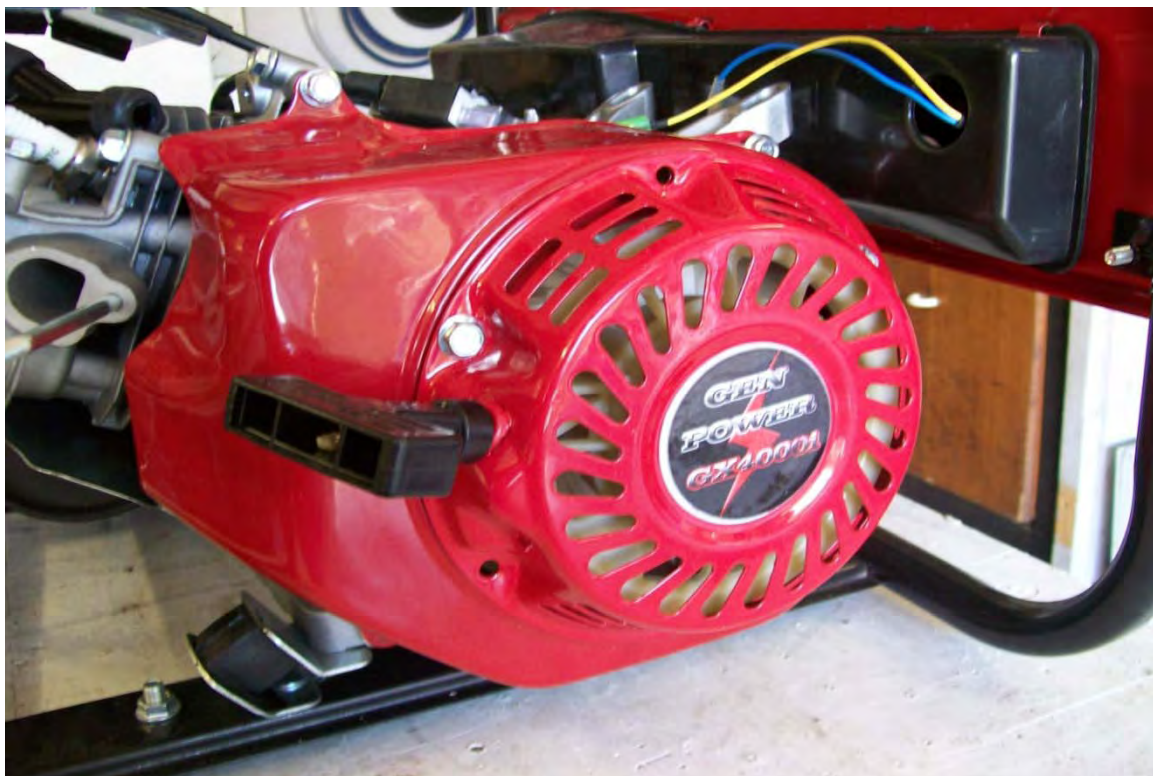

The manual Pull-start and the generator cover are now removed. It is only necessary to remove four of the bolts to take the cover off:

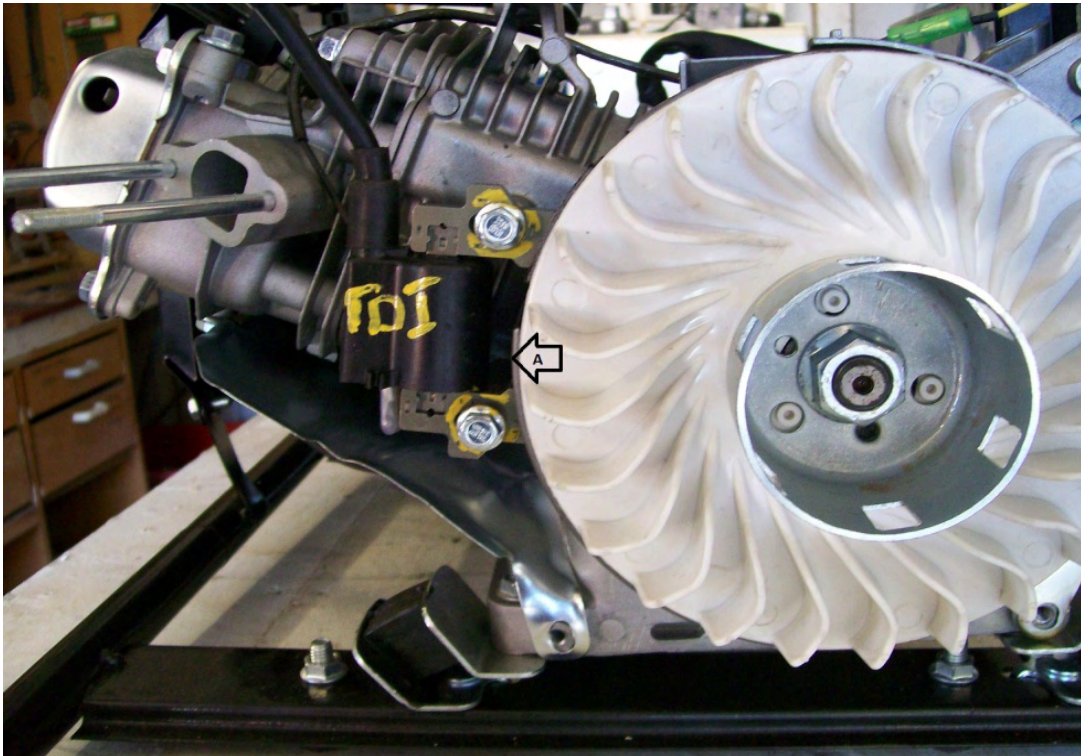

This is the engine with the starter pull and the blower cover removed. At "A" you can see the magnetic pulse type **Transistor Discharge Ignition** pick-up in it's original position, bolted in place at 8 degrees before Top Dead Centre. This needs to be removed and an aluminium plate inserted to allow the TDI to be mounted in it's new position. Because of the new fuel, it is necessary to retard the ignition system. This can be done in one of two ways, neither of which is particularly easy, so you may need the help of an engineering shop. The easiest way is to modify the installed ignition to Top Dead Centre. This is Selwyn's aluminium TDI adaptor plate which he made from 2mm thick aluminium sheet:



In this picture, the outline of the fuel intake port is obscured due to it having been temporarily blocked off during the construction. The tools required for constructing these components are a drill press and a jig saw fitted with a metal blade. Selwyn used this timing alteration method on his own smaller generator which has run trouble-free

for a year. The objective is to delay the ignition spark from 8 degrees before Top Dead Centre to either Top Dead Centre or to 1 degree after TDC. This allows for a good spark on the compression stroke and when the waste spark occurs, the inlet valve has not yet opened and so there is no HHO in the ignition area. That is to say, the exhaust valve has just closed and the inlet valve has not yet opened. This results in a good compression stroke for the HHO and does not try to send the piston backwards due to premature ignition of the gas mix. The above picture shows the aluminium plate mounted and ready to accept the pick-up. This plate needs to have air holes drilled in it in order to allow cooling air to flow over the engine fins behind it.

The TDI adaptor plate looks like this:



And as shown below, the support plate is drilled with the ventilation holes. In this photograph the adaptor plate is just resting on the support plate. Later, when the TDC timing position is established, the adaptor plate will be bolted to it using the three holes top and bottom on the white plate. This locks the timing to that setting and the timing is never changed. In 2010, when adapting a previous generator, an experienced mechanic was asked to establish the TDI plate position and he charged sixty Australian dollars for doing that.

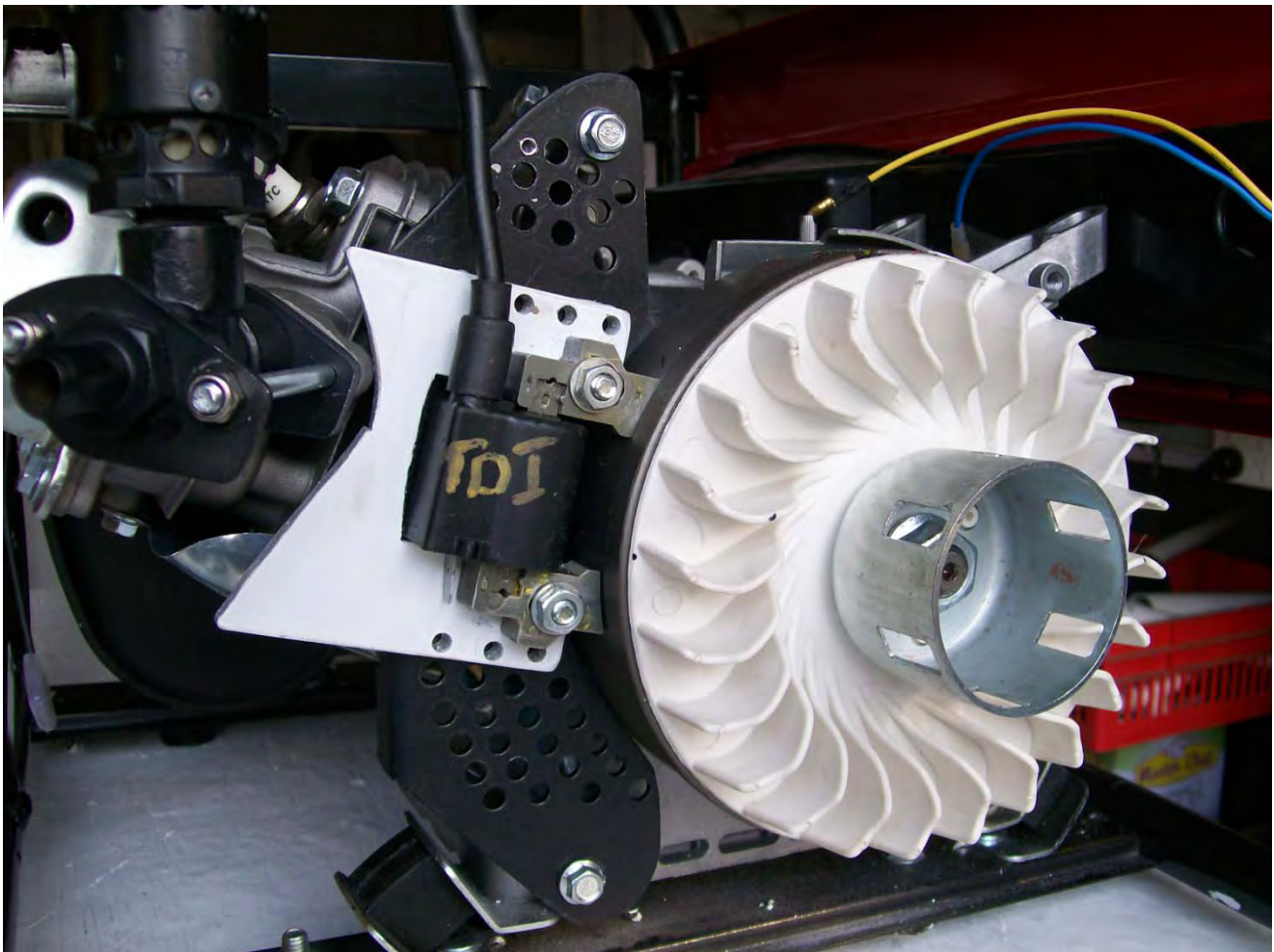

Finally, the covers and the Starter handle need to be bolted back in place.

Instead of paying somebody else to set the new spark timing, it is perfectly possible to do that yourself. One effective method is as follows:

1. Mark the casing of the engine in a convenient location as shown in yellow in this photograph:

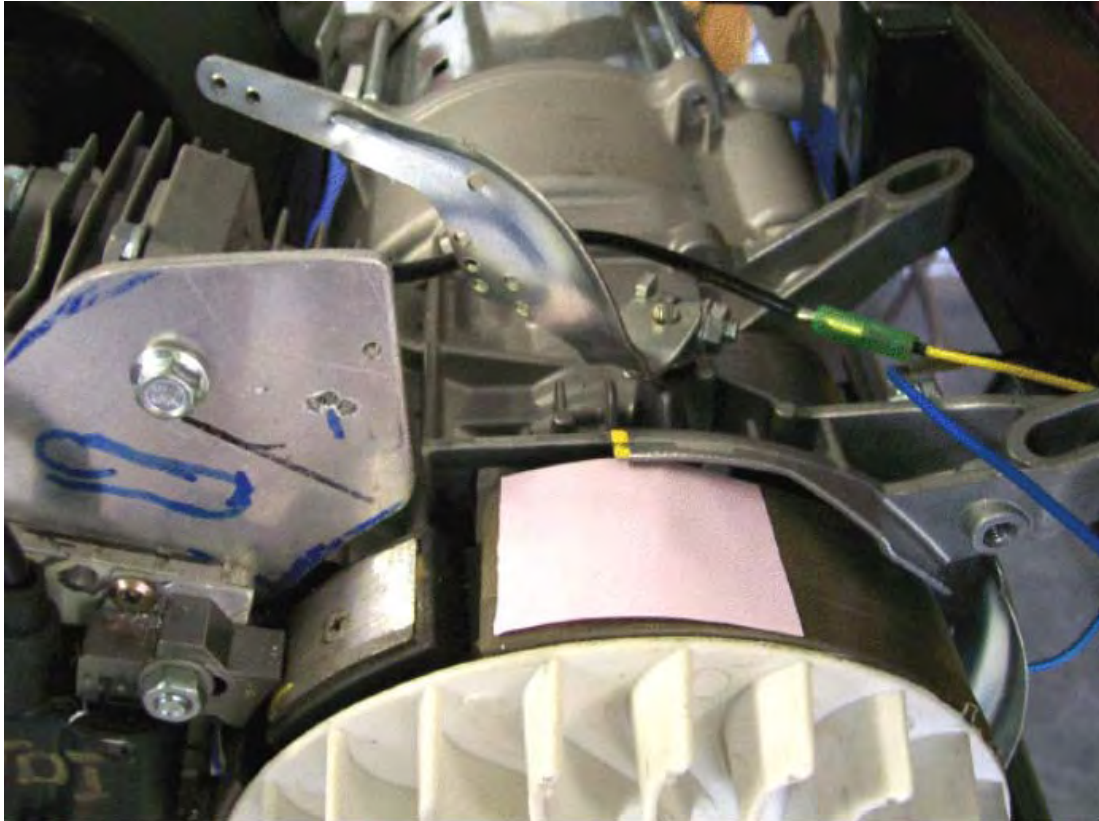

2. Remove the spark plug and insert a long screwdriver until the top of the piston is felt. Manually rotate the engine (clockwise for this generator as can be seen from the curved fan pieces on the flywheel) until the screwdriver is no longer pushed upwards. It may take more than one rotation to find this point accurately. When that point is found, mark the flywheel directly in line with the casing mark which you just made. This marking needs to be very accurate.
3. Continue rotating the flywheel very slowly until the screwdriver starts to go down again and mark that point on the flywheel. Again, this marking needs to be very accurate.
4. Measure the distance along the flywheel between the two flywheel marks which you have just made and then make a larger mark on the flywheel exactly half way between your two marks. If accurately done, this new point is where the flywheel is when the piston is exactly at Top Dead Centre, which is where we want the spark to occur. This marking on Selwyn's flywheel is like this:

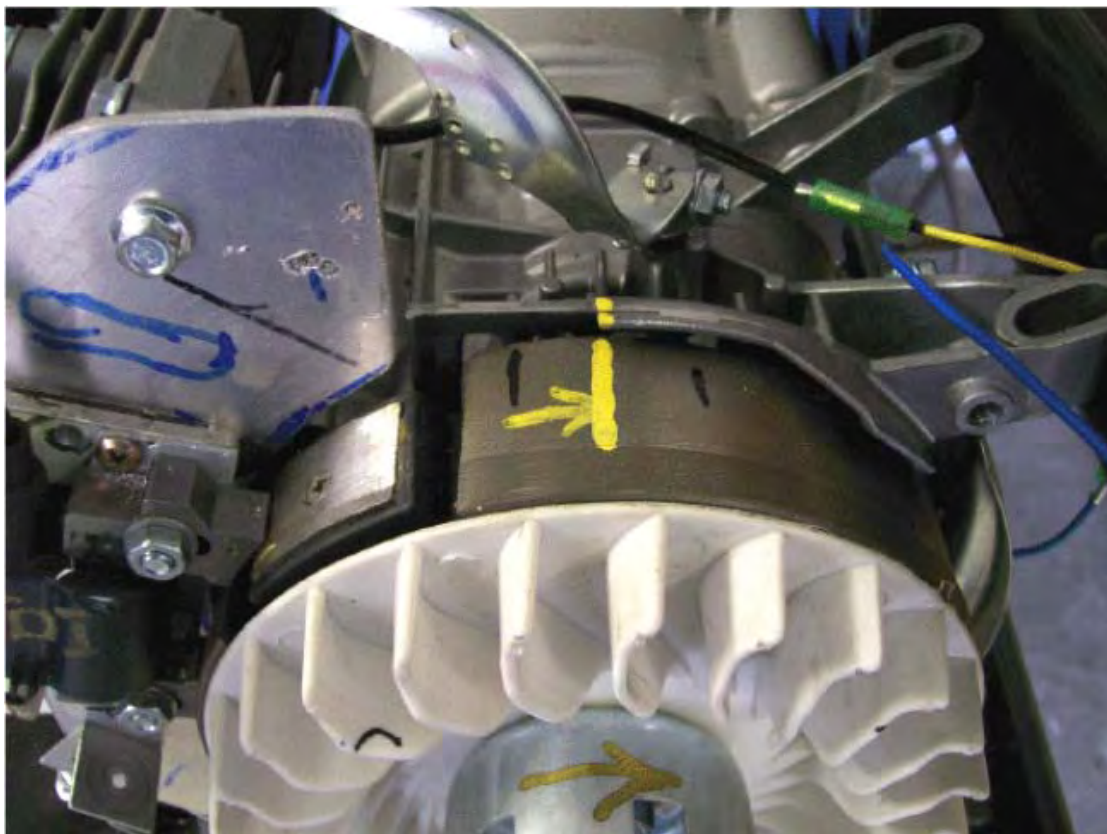

5. Next comes a bit of arithmetic. The diameter of the flywheel is 180 mm which means that its circumference is $3.14159 \times 180 = 565.5$ mm and as there are 360 degrees in each rotation of the flywheel, then the outside edge of the flywheel will move 1.57 mm for each of those degrees.

The engine specification states that the spark timing is 8 degrees before Top Dead Centre and we want the spark to occur exactly at TDC, which means that we want $8 \times 1.57 = 12.5$ mm of the flywheel circumference to have passed by before the spark occurs.

6. To achieve this delay in the spark timing, the TDI needs to be moved 12.5 mm in the direction which the flywheel rotates. You will notice that for this major timing change, the TDI adjustment is very small, only half an inch.
7. When the TDI adjustment has been made, the timing can be checked using an automotive timing light connected to the spark plug lead. The engine can be spun using an electric drill. As the flywheel is spinning fast and the flash of light from the timing light is very short, it makes the flywheel mark appear to be stationary in spite of the fact that it is passing by very rapidly. If the TDI adjustment is correct, then the central mark made on the flywheel will appear to be stationary and exactly aligned with the mark made on the casing.

This is exactly what happened when Selwyn's motor had its timing adjusted, but the important factor is to have the spark close to the Top Dead Centre point to make sure that the inlet valve is fully closed before the spark occurs. Two degrees after Top Dead Centre is a popular point for the spark with many of the existing generator conversions which I have been told about, possibly to reduced the loading on the piston's connecting rod. Here is a photograph of Selwyn's latest generator conversion having its new spark timing checked out:



8. Most small petrol engines have the spark timing set between 8 degrees and 10 degrees before Top Dead Centre. If it so happens that you do not know what the timing of your particular generator is, then complete the flywheel marking procedure of step 4 above, but make three additional marks on each side of the TDC mark. Space those marks 1.5 mm apart as they will then make a scale which shows each degree from 3 degrees before TDC to 3 degrees after TDC. When the timing light is used, it then shows exactly where the spark occurs and if the engine had an original spark timing which was not 8 degrees before TDC, then the scale shows immediately how much further the TDI needs to be moved to set the spark exactly where you want it to occur.

The Cold Water Mist.

Getting the fine droplets of water into the engine can be done two different ways. The first way is to use a Venturi tube which generates a fine spray of droplets when air moves rapidly past a small water-filled hole. You may not have noticed, but this method has been used extensively in perfume sprays and it is very effective. Selwyn describes how he constructs a Venturi tube:

A short length of 1/4" (5 or 6 mm) diameter copper tubing is used. This is generally available as central heating supplies and if there is any difficulty in finding some, then your local garage can probably direct you to a supplier (if they don't just give you a short length from their own supply).



The copper pipe is then heated with a plumber's gas torch and bent very slowly and carefully to the shape shown above. Some people find it helpful to insert a length of suitable flexible material into the pipe before starting the bending – something like the coiled steel spring material used to support net curtains – as that helps to keep the copper pipe from kinking when being bent.

Next, the end of the copper pipe which will form the nozzle, is filled with silver solder and the end filed flat. Then, a small hole is drilled through that silver solder plug. The smallest possible drill bit should be used for this, although the hole may need to be drilled out to a slightly larger diameter, depending on what the engine requires (which is found by successive trials):

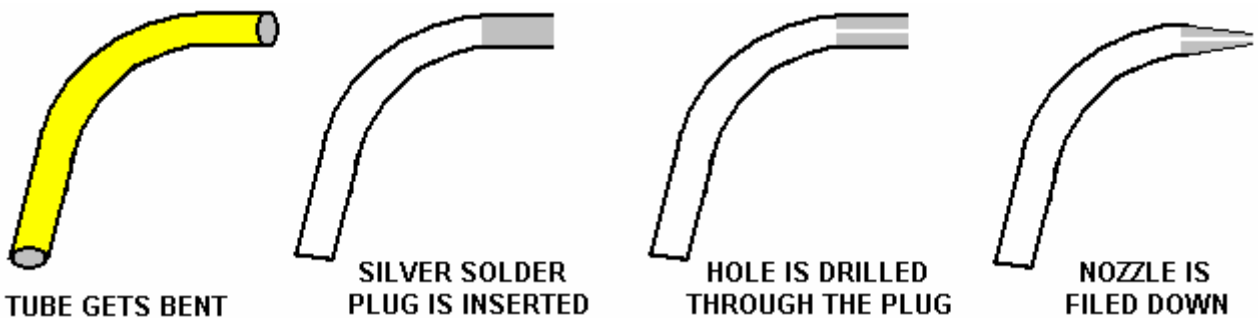

This Venturi tube is to be inserted into the last brass fitting before the engine, so a 1/4" hole is drilled through the brass and then the drill is removed very slowly at a slight angle, the angle of drag being down the axis length of the brass fitting. The copper Venturi tube is then inserted through the hole and positioned so that the Venturi hole is aligned up exactly with the centreline of the brass fitting and positioned exactly in the middle of the cross-section of the brass fitting and then soldered in place:

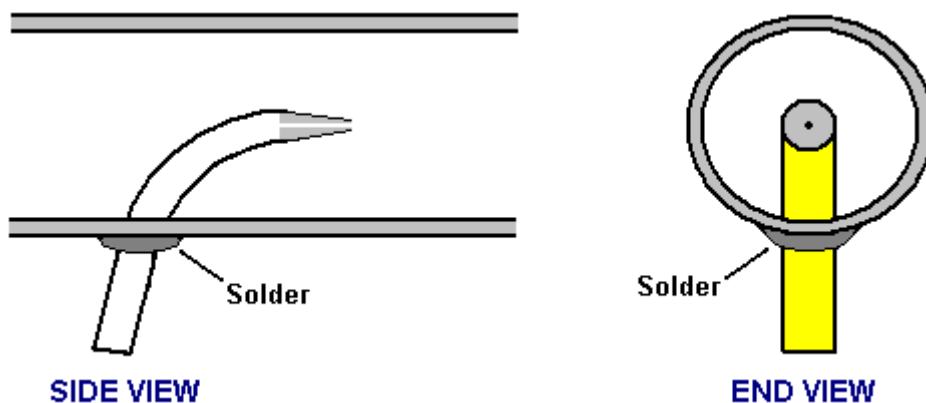

The method which Selwyn uses to block off the end of the copper tube with silver solder is to seal the far end of the tube with tape and fill the tube with fine-grained sand like this:

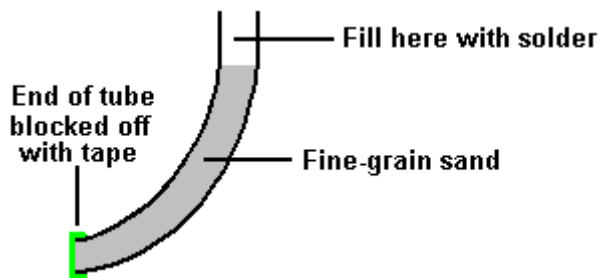

And then the tube is heated with the gas torch flame and the solder run into the top part of the tube. When the solder has cooled, the tape is removed and the sand removed by tapping the tube. When the hole has been drilled through the solder, air is blown through it to dislodge any remaining sand, and then water is forced through the hole. As the tube is short, any remaining sand can be removed with a pipe-cleaner or any similar slender cleaning device. The installed Venturi tube can be seen here:

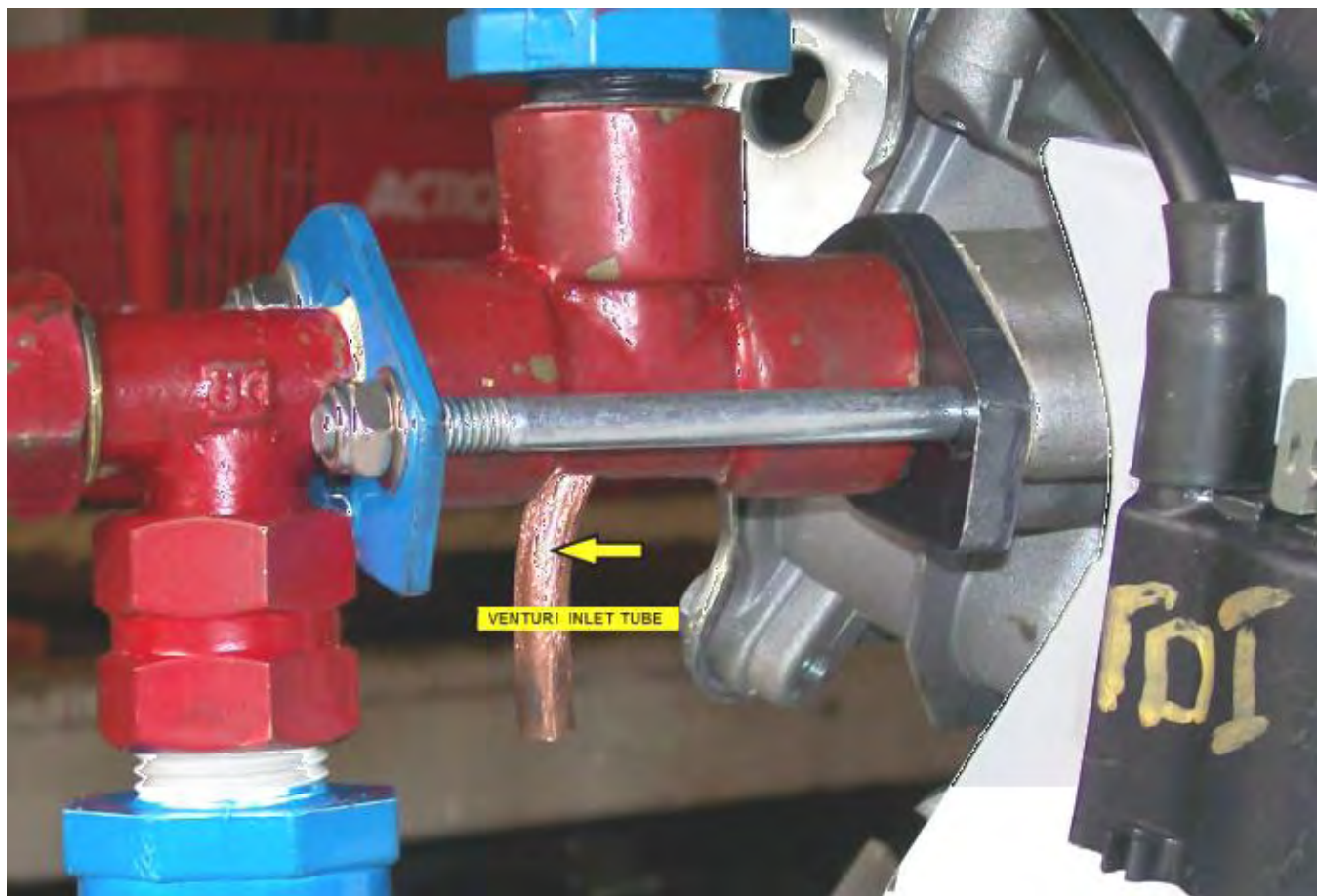

The second way to introduce cold water mist into the airstream entering the engine is to use a commercial "pond fogger" which can be bought at pet supplies outlets. These have to be powered electrically and housed in their own water container. Some of the more advanced versions float on the surface of the water so that the fog-generating section is always submerged to the ideal operational depth below the surface of the water.

The generator should run well with 5 lpm of HHO gas plus cold water mist. Any design of electrolyser can be used. However, when used with rainwater, the Hogg electrolyser will draw about 1.4 amps per cell, giving a total input of about 115 watts when run on a 12-volt electrical supply. While rainwater is supposedly pure, the reality is that it seldom is and its ability to carry a current varies dramatically from place to place and even more widely from country to country. However, regarding the water, Selwyn says:

The water I use is treated in a special way to make sure that the electrolyser runs at the lowest temperature and amperage possible. For this, using rain water is a must and the rain water coming off a steel roof is the best.

The water is then treated by inserting a double coil of stainless steel wire into a volume of about 5 litres of water. A supply of 12-volts DC is applied to the coils, and the resulting current allowed to run through the coils for about 5 hours. This results in hot and very dirty water. The water is then filtered using a 0.5 micron filter making the water ready for use in the electrolyser. If more water is needed, say 30 litres, then leave the coils running for at least 24 hours.

I use an old 35 litre beer keg and prepare 30 litres at a time. A major reason for doing this is to remove all the solids suspended in the water so that they will not clog up the stainless steel mesh inside the electrolyser.

After the construction of the Hogg electrolyser is completed, then the stainless steel mesh electrodes need to be treated and cleaned. For this I use distilled water and fill the electrolyser enough to cover all the plates, and then add 1 packet of citric acid for each 3 litres of water used to fill the electrolyser. I got the citric acid from www.hho-research.com.au which is an Australia-only supplier and each packet has about 22 grams of citric acid in it:



The pumps are then run for about an hour after which the Hogg tubes are washed out completely with distilled water and then allowed to dry completely. This removes any residue from the stainless steel mesh electrodes, making the gas production rate much greater.

I use an ordinary car battery to generate the HHO gas needed to start the generator running, after which, a standard battery charger powered by the generator output is used to keep the starting battery topped up.

Please Note: This document has been prepared for information purposes only and must not be construed as an encouragement to build any new device nor to adapt any existing device. If you undertake any kind of construction work, then you do so entirely at your own risk. You, and only you, are responsible for your own actions. This document must not be seen as an endorsement of this kind of generator adaption nor as providing any kind of guarantee that an adaption of this kind would work for you personally. This document merely describes what has been achieved by other people and you must not consider it as being a foolproof blueprint for replication by anyone else.

There are YouTube videos which show generators being operated on what appears to be just HHO gas alone and while the operation does not appear to be anywhere close to full power, the addition of cold water mist would probably make a major difference to the performance, but it does demonstrate that a generator can certainly be run without using any fossil fuel. The spark circuit in the first video appears to be powered by a small mains unit, but as the generator is lighting a powerful lamp, that electrical input could almost certainly be met by the output from the generator when it is running.

Running an Unmodified Generator on HHO

The reason for the modification of standard generators as shown above is due to the fact that the HHO gas mix produced by an electrolyser, ignites about a thousand times faster than a hydrocarbon fuel, and because of that, the spark which ignites the fuel needs to be delayed. That mechanical adaption of the generator can be avoided if the HHO gas mix is modified so that it ignites more slowly. This can, and has been done.

David Quirey of New Zealand has been operating an unmodified generator and a welding torch on the HHO output from his 6 lpm own-design of electrolyser, for many years now. Henry Paine's US Letters Patent No. 308,276 dated 18th November 1884, states that HHO gas can be converted into a more convenient gas which is much easier to handle, by the simple process of bubbling it through a suitable liquid such as turpentine or linseed oil. Although unaware of Henry Paine's patent, David discovered the technique independently and he has extended the technology further so that the gas ignition speed can be set manually.

One important point which David stresses is that it is essential that the HHO coming from the electrolyser is passed through an ordinary bubbler containing water, before it passes through the second bubbler containing the

modifying liquid. David finds that the lighter liquid, acetone, works better than the liquids suggested by Henry Paine although white spirit, carbon tetrafluoride, aviation fuel, hexane or even petrol can be used and any of them will slow the flame speed right down to that of butane. If the flame is being used for a specialist task such as jewellery making or glass blowing, then there may be an advantage in using one particular modifying liquid.

David has further modified the characteristics of the output gas by adding in a percentage of the unmodified HHO gas. Although it is actually, subtle and sophisticated, David's overall system is easy to understand. The ratio of the two gasses is adjusted by the settings of the two control valves as shown here:

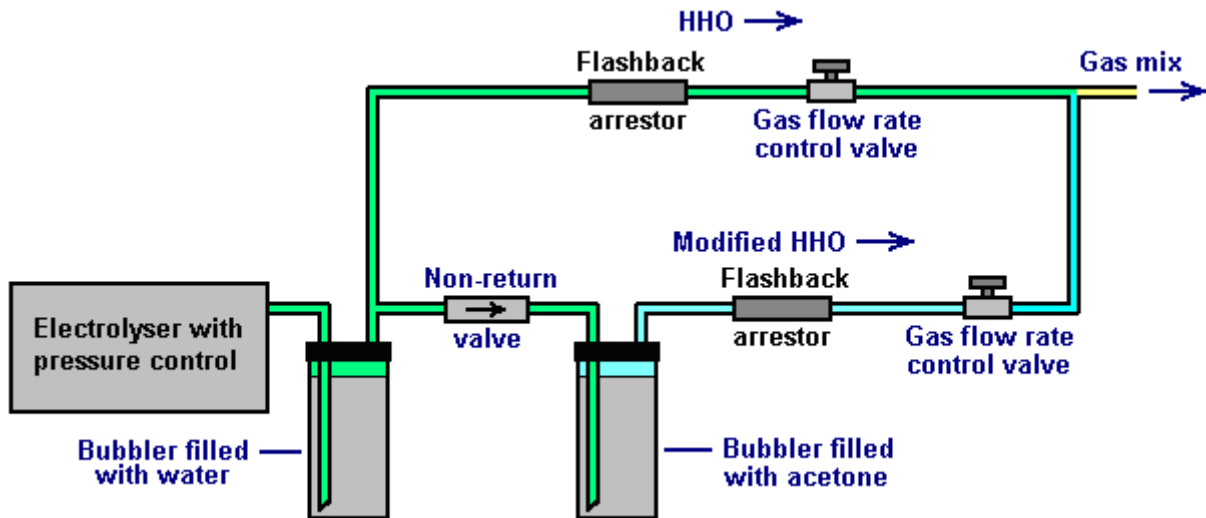

Adjusting the ratio of modified HHO to unmodified HHO allows a high degree of control over the characteristics of the resulting gas mix. Added to that, David has developed an electronic control system which oversees and manages the gas flow rate according to the user's needs at any given moment. The result is a system which allows water and electricity to be the means of supplying a gas which can be used as a safe, general purpose fuel. If it is used to run a generator, then the system appears to become self-powered if part of the generator output is used to drive the electrolyser. It should be possible to substitute the modified gas mix for propane or butane and so operate a wide range of existing equipment for heating, cooking and/or lighting.

David runs a 4 horsepower Honda generator using this system:



The generator runs very well for David, however, I suspect that if cold water mist were introduced into the incoming air, then the power output would be increased due to the mist turning into flash-steam and providing greater pressure on the piston during it's power stroke. Alternatively, it might be possible to match the present performance with a lesser gas flow rate, possibly powering a much larger generator if that were a requirement.

It needs to be understood that David uses electronics which manages and controls the gas flow volume, suiting it to whatever the needs are at any given moment. Consequently, it is probable that the six litres per minute which

David's electrolyser can produce, is not actually used for most of the time. David also does welding, brazing and cutting with the same modified electrolyser gas mix which can provide adjustable flame heat and a flame length of anything up to two feet in length:



It is a good idea to use a proven design with full control electronics. David can help here with detailed step by step construction plans and instructional videos.



You can contact David at dahq@clear.net.nz for information on what is available to help you at the present time.

When using the system for welding, David uses the mains to power the electrolyser, the arrangement being like this:

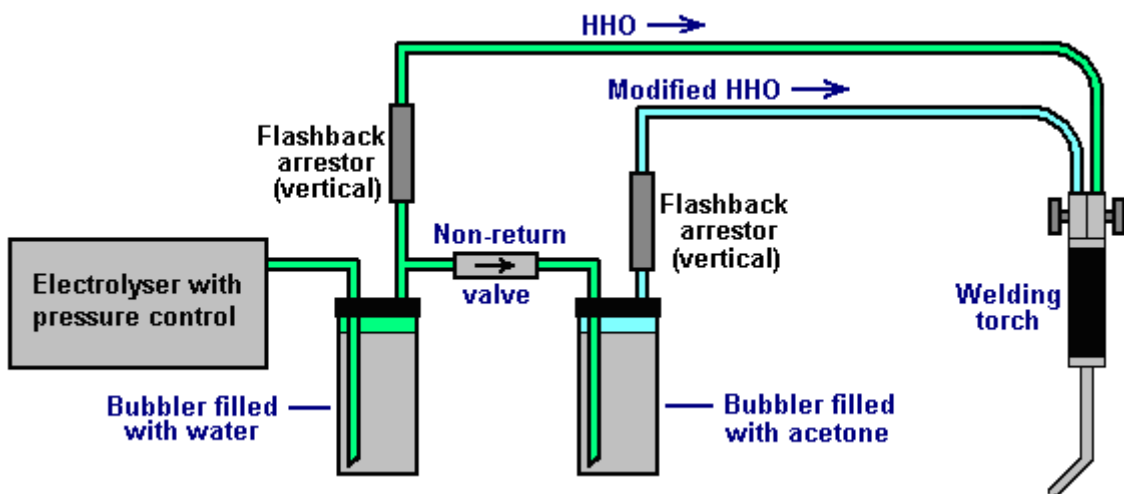

The flashback arrestors are a sand-filled design and so are mounted vertically. The gas production rate is knob controlled using this circuit:

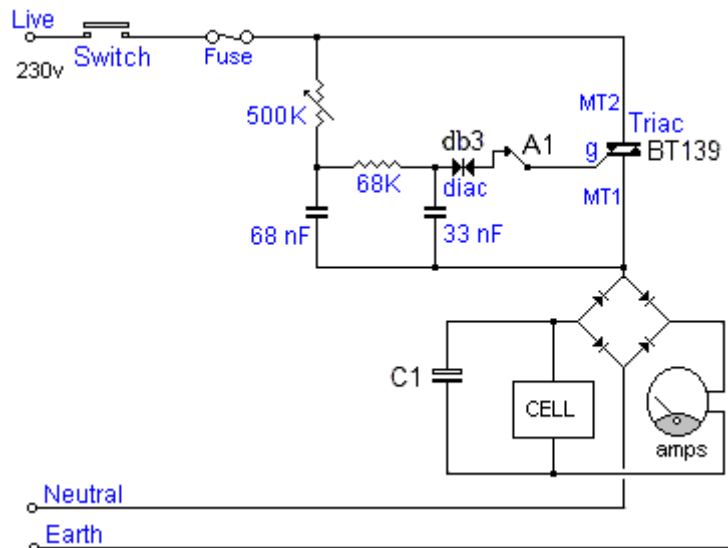

The first part of David Quirey's circuit acts very much like a dimmer light switch. The 230-volt AC mains is fed through an On/Off switch and then an ordinary mains fuse. The current flow on through the circuit is blocked by the BT139 triac until it receives a pulse from the db3 diac (which is a component specifically designed to feed pulses to a triac).

As the voltage builds up on the 68 nanofarad capacitor it eventually reaches the point at which it triggers the triac, which then switches on and remains on until the mains voltage drops down to zero again. The 500K variable resistor sets the rate at which the capacitor charges up, and so it controls the length of time that the triac is on in any given second (and so, the level of power fed onwards to the rest of the circuit). This happens on both the positive-going half of the AC waveform and the negative-going half of the mains sinewave voltage supply. Both the diac and the triac operate with AC and trigger either 100 or 120 times per second depending on the frequency at which the local mains runs.

The current flow is then passed to a bridge rectifier in order to convert the AC into pulsing DC and the capacitor C1 which is 400-volt rated, smoothes the resulting DC. David's cell has a large number of plates and so, operates off the 300 volts produced by this system. The ammeter between the diode bridge and the cell indicates the current flow and so, the amount of gas being produced at any given moment.

The flashback arrestors are constructed as shown here:

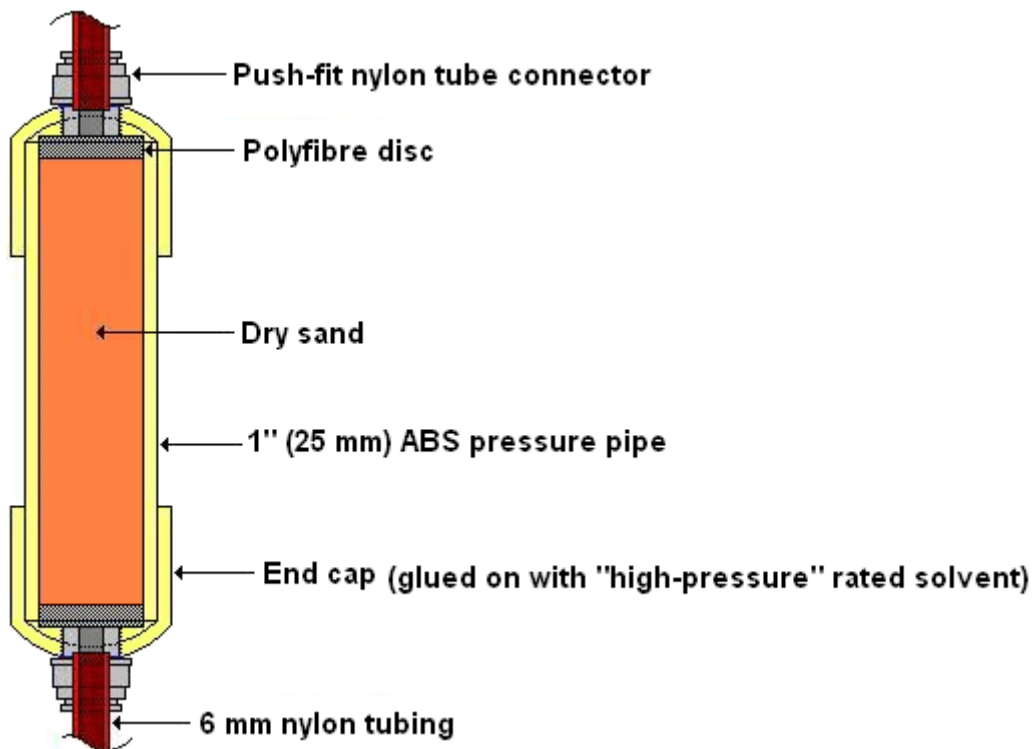

Sincere thanks are due to David Quirey for freely sharing his design and experiences, and for his willingness to provide direct additional support and further details should they be needed.

Stan Meyer's Water Injection System.

While the above simple adaption will work for an electrical generator which is stationary and which is designed to provide large amounts of electrical power, some of which can be used for producing hydroxy gas from water, it is much more difficult to run a large capacity petrol/gasoline engine continuously with just water as the "fuel".



For larger engines aimed at producing mechanical output, we need a more powerful system, such as that developed by Stan Meyer of America. Although many years have passed since the sudden, highly suspicious death of Stan Meyer, as far as I am aware, his design has not been replicated, mainly because people do not understand the information which he left behind. However, recently, a man whose forum ID is "H2Opower" has helped explain what Stan meant, and much of the following description is down to his sharing his understanding publicly and freely.

Stan's Canadian patent 2,067,735 has an arrangement where the injector schematic shows the injection into the engine of three separate components:

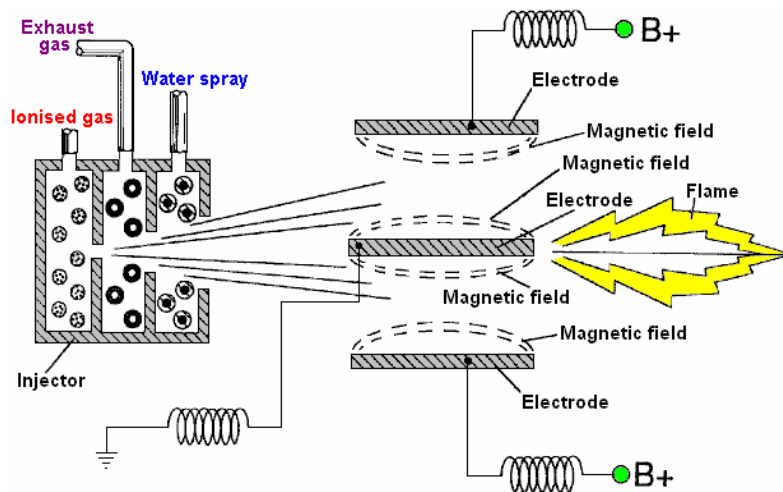

One component is described as ionised gas and ambient air is mentioned. The second component is part of the exhaust gas which is hot water vapour fed through a limiting valve, referred to as "inert gas". The third injection component is a very fine spray of water droplets or cold water "mist". This three-component mixture is passed between high voltage electrodes and if the mix does not ignite spontaneously, then it is ignited with a spark.

One version of Stan's recommended injectors for an existing engine are shown like this:

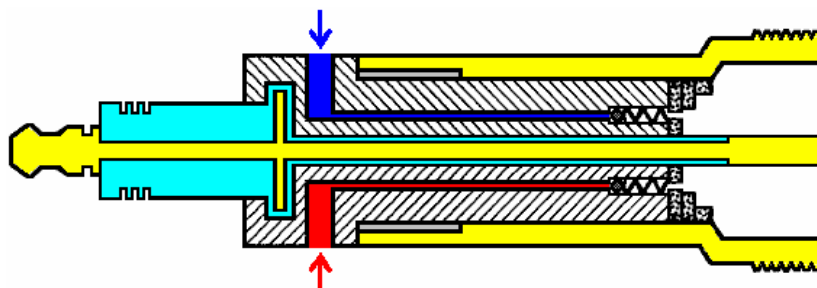

This is a cross-section which only shows two of the three gas inputs flowing through this injector/spark plug. Each gas input has its own feed passage which leads out between the central electrode and the circular outer electrode, and each feeder tube has its own one-way valve to prevent the power stroke from forcing the incoming fuel back up its feed tube.

This is only one of the ways that Stan shows that it can be done. Here is his diagram for a two cylinder engine fuel input, although it applies equally as well to any number of cylinders:

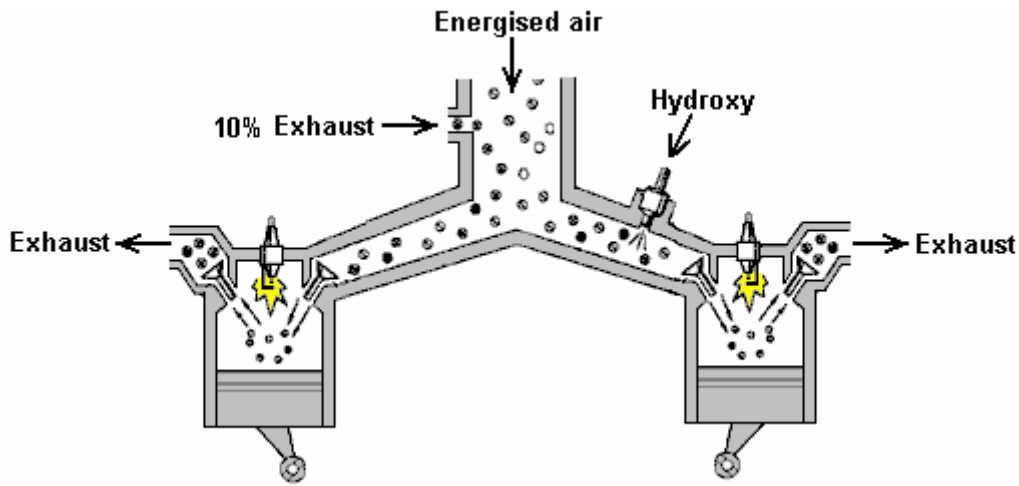

Let me stress that this is just an explanatory diagram and you do **not** have the intake and exhaust valves open when the spark plugs fire. Also, the pistons do not go up and down together but their movement is staggered to give a less uneven drive to the crankshaft. The point to note here is that the fuel intake is through standard valves and ordinary spark plugs are shown. However, this diagram for US Patent 5,293,857 is based on the use of an electrolyser and Stan found a way to avoid the need for an electrolyser.

For this, Stan's "Gas Processor" is a really key device in spite of it being what appears to be a fairly simple construction. It operates by pumping light energy into the fuel components. This may not sound like a big deal but it most definitely is, in fact, it is the heart of Stan's system. In addition to the extra energy, the fuel components are also stressed by high-voltage pulsed DC applied in such a way that it tends to pull the molecules apart as they flow past into the engine.

The Gas Processor is constructed from two highly reflective metal cylinders, 96 Light-Emitting Diodes ("LEDs") and a carefully adjusted high-voltage pulsed DC source. The reflecting tubes are used to make the light bounce backwards and forwards indefinitely until it is absorbed by the passing molecules. The choice of LEDs is very important as the wavelength of the light needs to be matched to the resonant frequencies of the fuel components passing by. Laser LEDs can be used but they need to be angled slightly in order for them to bounce and completely fill a section of the Gas Processor gas passage.

The operation is simple in concept. Six banks of sixteen LEDs are installed in the outer cylinder which has a polished inner surface. To see the effect of each LED, consider just one LED on it's own:

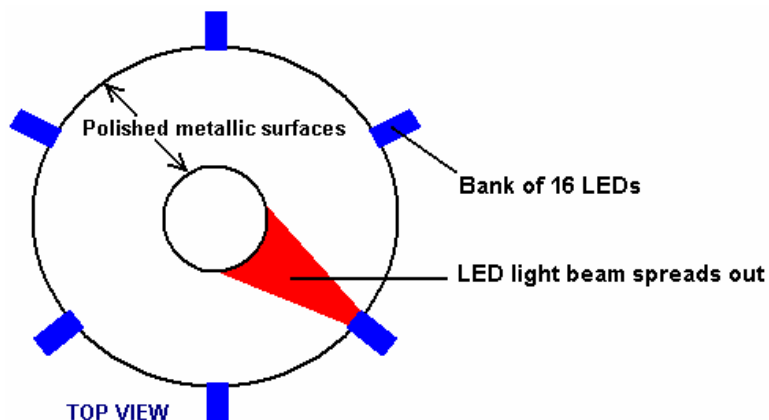

The LED light shines on to the inner tube which has a highly polished outer surface. In the diagram above, the light is shown in red, and the uppermost LEDs of the six columns of LEDs can be seen. The light is then reflected back to the outer cylinder again:

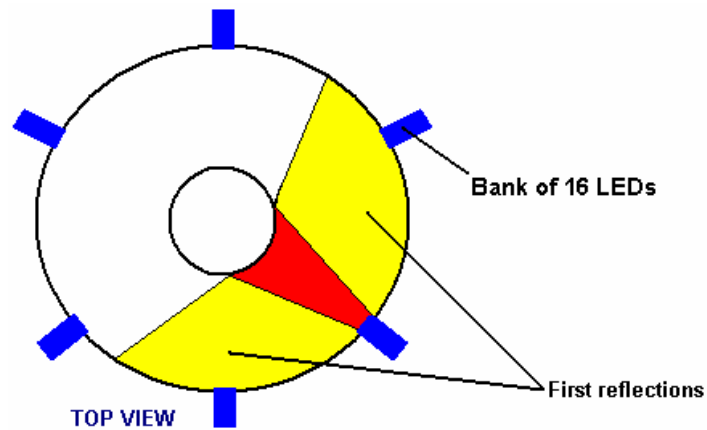

The reflected light is shown here in yellow although it is identical in wavelength to the section shown in red. This reflected light is again reflected by the outer tube and that repeats over and over again until the whole of the area between the two tubes is completely filled with the light. This will happen with just one LED, and that light will continue to be reflected backwards and forwards indefinitely if it does not collide with a gas molecule. That is the effect of just one LED, but there are six LEDs at that level, each producing light of the same frequency and reinforcing the power of each of the other five LEDs, producing a very powerful overall band of light.

The same thing happens in the vertical plane with the light bouncing all the way down the tubes, and as the LEDs at different levels generate different wavelengths, there is a powerful interaction between the different frequency waves, producing intermediate frequencies by a process with the technical name of "heterodyning":

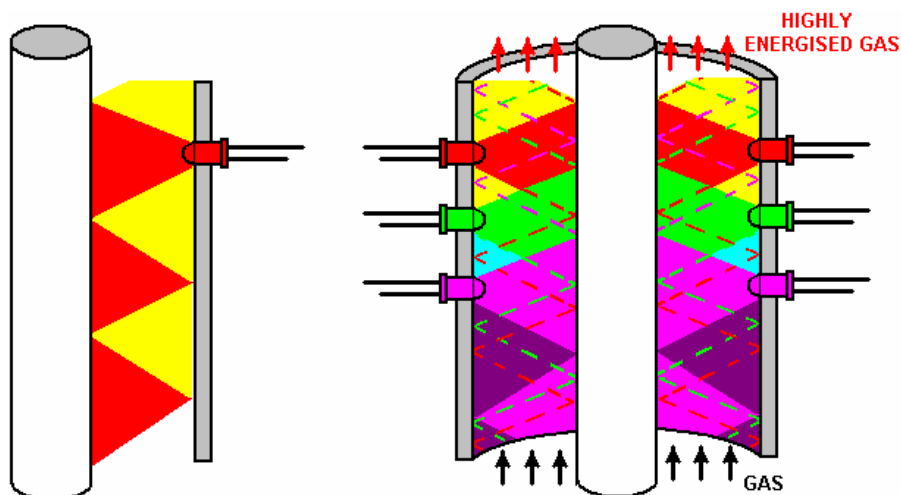

In this diagram it has not been possible to show the way in which the reflected light from each LED interacts with the light from all of the other LEDs, but there is a complete intermixing of the beams. The LEDs are shown with greatly exaggerated size and spacing in order to give a reasonably understandable diagram.

The diagram above, barely indicates the level of light intensity inside the Gas Processor, and that is from only six of the ninety six LEDs actually installed. It is a little difficult to visualise this device, but the gas (of whatever type) flows up through a circular doughnut-shaped space between two pipes and is hammered by a very high level of light energy of the appropriate frequency. "H2Opower" believes that the optimum LED frequencies are as shown here:

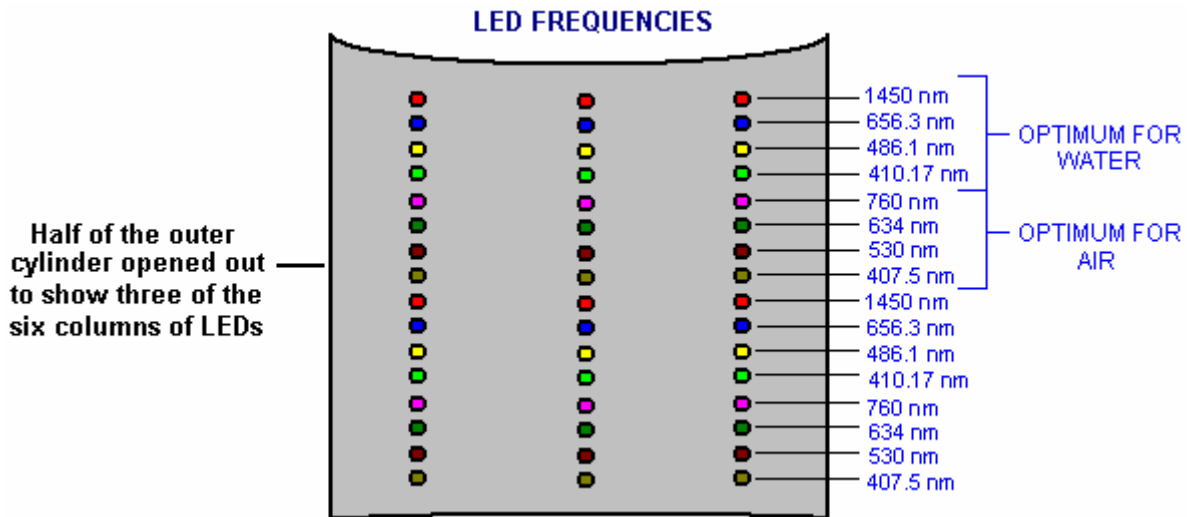

and while, not surprisingly, I have not been able to find an LED supplier for these exact frequencies, most LEDs emit a band of frequencies rather than just a single frequency, so the working LEDs need to include the frequencies shown here.

The operation of the Gas Processor is further enhanced by applying a pulsed high-voltage between the inner and outer metal cylinders. This voltage stresses the molecules of the gas flowing between the two cylinders and because it is pulsed, it applies a tugging action on the molecules, tending to pull them apart:

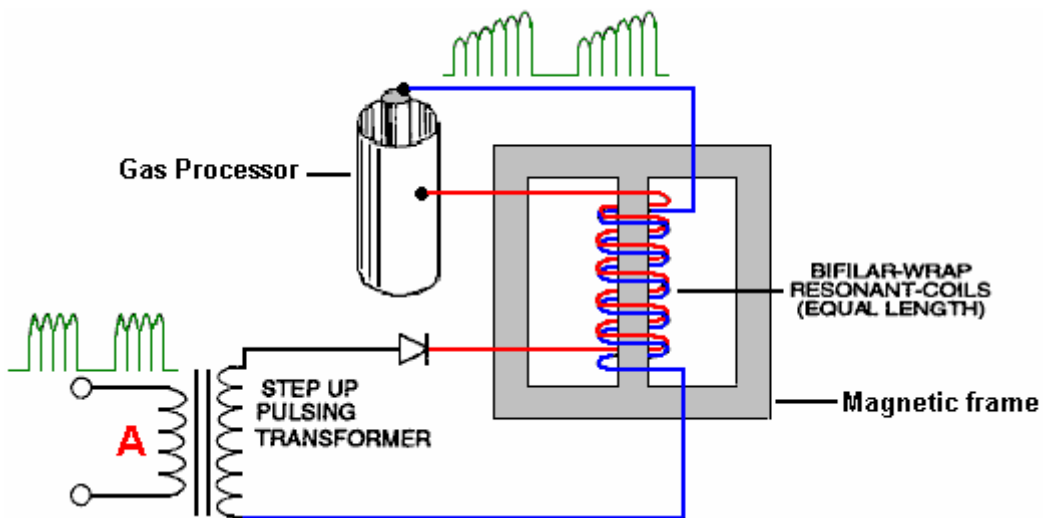

As with all high-power free-energy systems, having the device operate in resonance is very important. If it is still available, the excellent video: <http://www.youtube.com/watch?v=kQdcwDCBoNY> shows what resonant circuit operation is all about. Briefly, the frequency of the driving waveform passing through winding "A" in the diagram above, is adjusted until almost no current flows through that winding. This is the same as tuning a radio to a particular radio station - in both cases, the signal at that frequency finds it almost impossible to drive any current through the winding. This would make you suspect that almost no current would flow in the output winding, but that is not the case because that current flows into the secondary winding from the local environment (after all, here is no electrical connection between the two windings, so common sense tells you that the electrons flowing in winding "A" do not flow out of the other winding). This resonant operation gives you a major energy gain courtesy of the local environment.

The objective of the Gas Processor is to modify whatever gas is flowing through it, air, water vapour, hydroxy, or whatever, to one of it's highly charged, highly energetic states. The high voltage applied to the metal cylinders of the Gas Processor does not flow through the gas between the cylinders. Instead, it provides a very high electrostatic Plus charge on the outer cylinder and a very high Minus charge on the inner cylinder, and these two opposing charges pull the charged parts of each molecule towards themselves. The positively charged gas ions get pulled towards the Negative inner cylinder and the negatively charged gas ions get pulled towards the Positive outer cylinder. Stan uses this technique on the incoming air when he uses an electrolyser to power an engine:

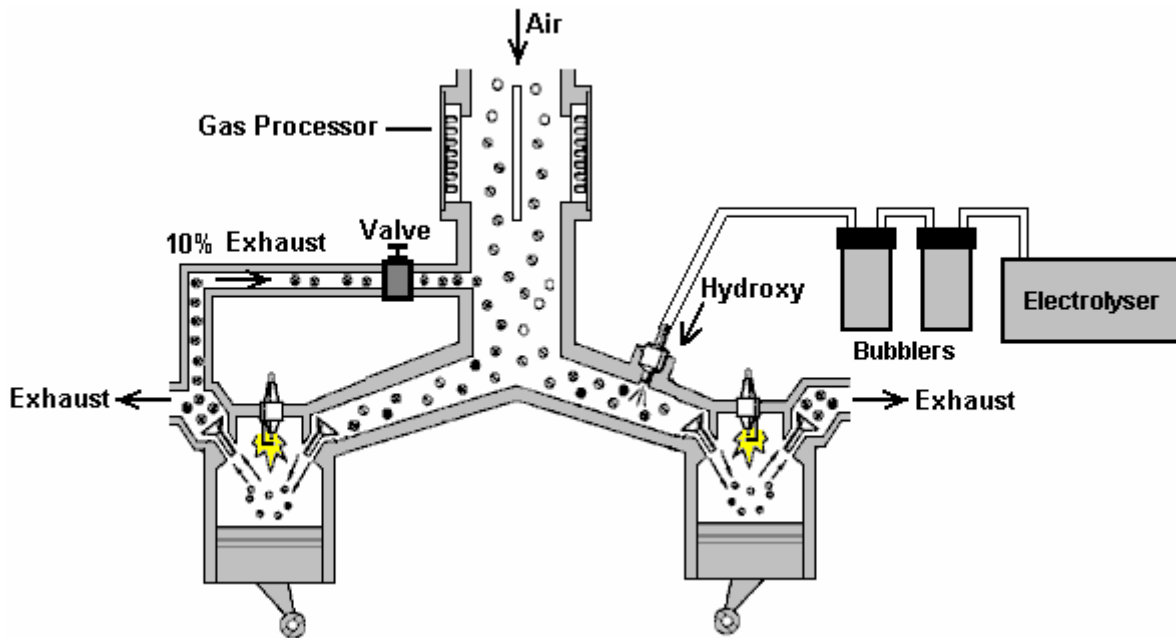

However, Stan's preference is to use air, water mist and some of the exhaust gas from the previous power stroke to power his engines. This is an effective method as "H2Opower" states that he has blown part of a car engine clean through the bonnet of the car, and that indicates that there is plenty of power available from those three components (although, ideally, you want to get the timing right and not over-stress the engine!!).

One thing that "H2Opower" points out is that the injectors supplied for converting any car to run on alternative fuels such as natural gas, can be adapted to be the equivalent of Stan's specialised injectors, if a pair of high-voltage electrodes are added to each injector and fed from a pulsed circuit such as Stan's "Voltage Intensifier Circuit". The arrangement would then be like this:

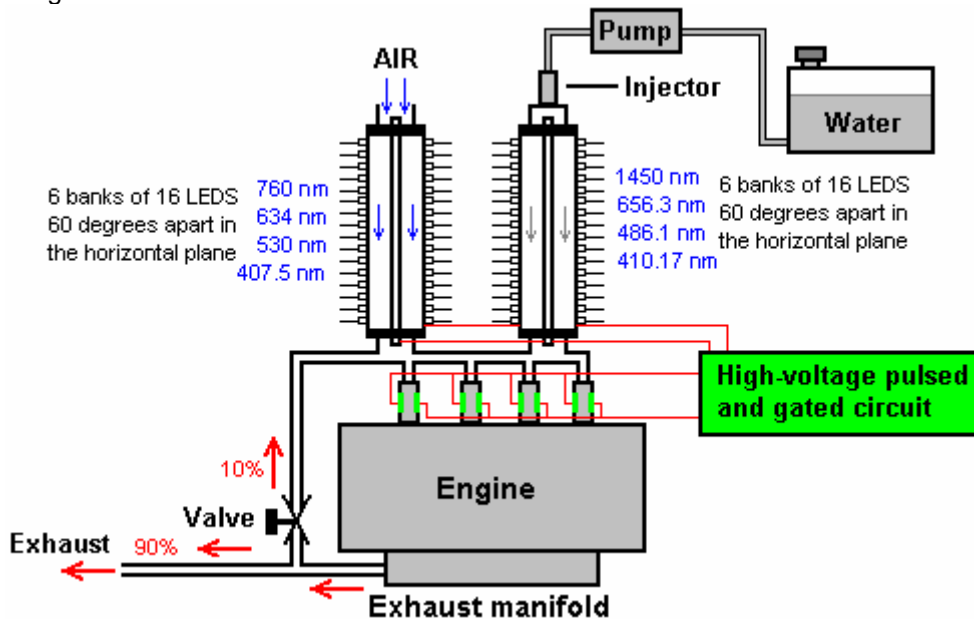

A 220-page "Technical Brief" from Stan Meyer at <http://www.free-energy-info.co.uk/MeyerData.pdf> can be downloaded free, although it may well provide you with more information than you ever wanted to know about the subject.

Peter Lindemann's Lawnmower Running on Water Alone.

Peter Lindemann has shown that a much simplified version of Stan's injection system can operate small engines directly on water alone. Let me suggest that it is not the water which causes the explosion, but instead, that the high-power spark causes disassociation of some of the water vapour, producing hydrogen and oxygen which then ignite, turning the remainder of the water vapour into flash-steam, making the engine operate as an internal combustion steam engine. The <http://www.youtube.com/watch?v=p3NE8P0sPS8> video shows a lawnmower engine operating on a spark which occurs ten or eleven degrees before Top Dead Centre:



Developed in conjunction with the EnergeticForum, the technique is based on the Aaron/Gotoluc style of operation with the circuitry shown in this video: <http://www.youtube.com/watch?v=vOhNtRhJ5Rw> although the "DirectHits" spark-booster shown at <http://www.pulstar.com/directhits.cfm> might well make the circuitry easier. Obviously, using this technology to operate a standard electric generator would be a major objective, especially since there appears to be little need to adjust the existing spark timing much.

Peter Lowrie's High-Current Electrolyser System.

Peter Lowrie of New Zealand developed an electrolysis system for use with internal combustion engines. Like the previous systems, Peter feeds a spray of fine water droplets into the engine, using a carburettor, supplied by a water tank. He also feeds in some exhaust gas and heated hydroxy gas, which is a technique which is almost identical to Stan Meyer's method.

Peter also produces a very large volume of hydroxy gas with a most unusual method. He uses a delta-wound, GEC marine alternator (though he says that the alternator from a truck would do). He modifies the alternator by removing the diodes inside it and leading each of the three phase-windings out to his electronics. He uses each of the three phase-windings to power one electrolysis cell. He applies only 2 volts or so, to the DC winding of the alternator, which is about the minimum which allows the alternator to work.

The DC current supplied is less than one amp while the pulsed current to the electrolysis cells is much higher. When a snap-on ammeter surrounds the wires to the cells, a current of at least 800 amps is displayed. A point of particular interest is the inductor (coil) placed between the electrolysis cells and the windings of the alternator. Peter describes this as a choke out of a 3-phase industrial power supply. It is comprised of a laminated steel core with a sheet of copper wound around it. This is remarkably like the arrangement used by Stan Meyer and already described earlier in this document.

Peter has run a 1,600 cc car engine at 5,500 rpm with the gas output from his cells. He believes that his method of cascading the gas output from the cells through each other, produces a more active form of hydroxy gas. He also uses a heat-exchanger which allows the exhaust to pre-heat the hydroxy gas before it is passed to the engine (a method also used by Stan Meyer for running a car on water alone). Peter also uses impulse-operated valves to control the flow of gas to the engine as shown here:

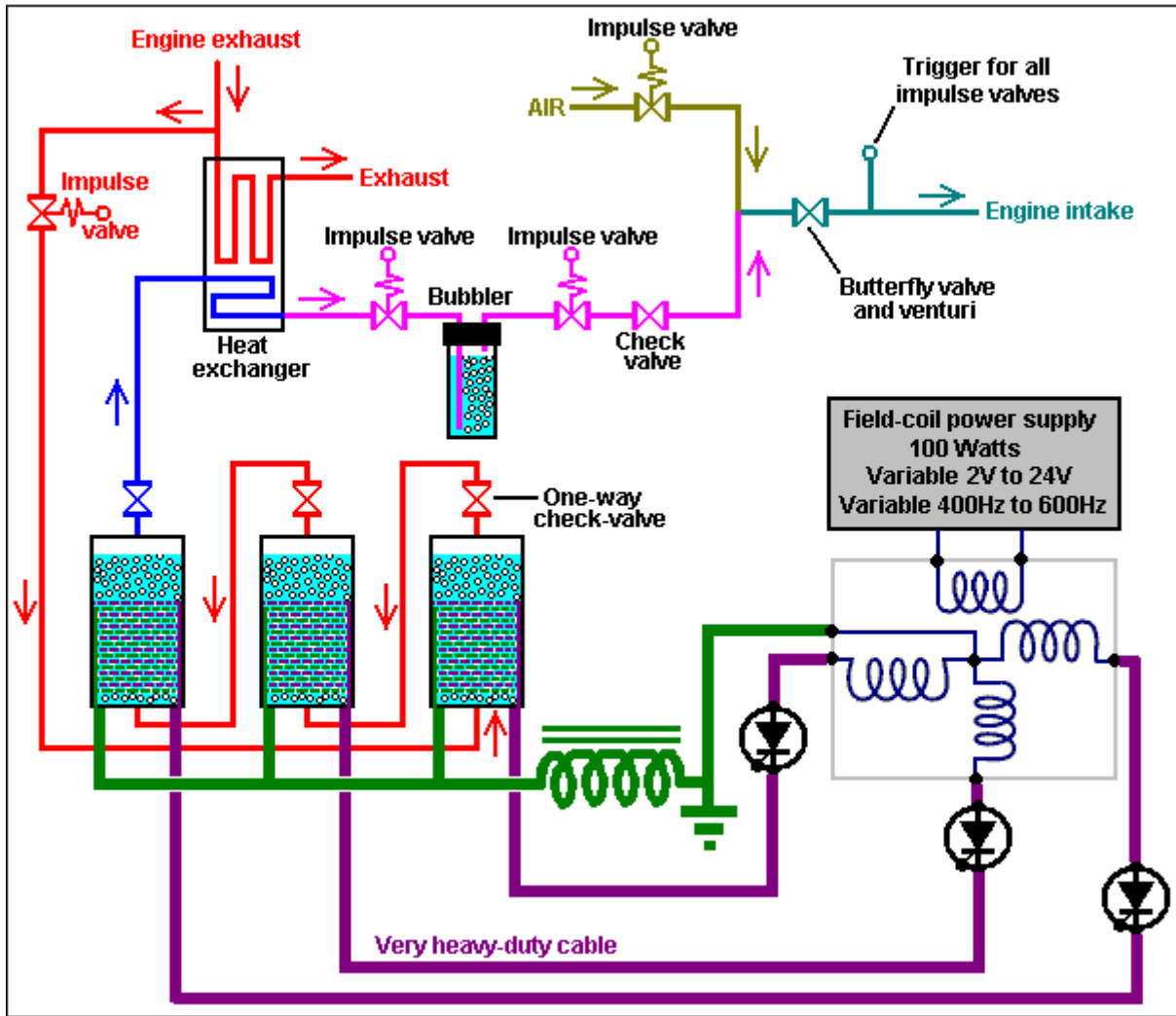

The Use of Water in Engines.

I can fully understand someone having difficulty with accepting the idea that water can be used as part of the fuel inside an internal combustion engine. However, there is an old saying that "fact is stranger than fiction" and that certainly appears to apply in this case. First, it is essential to accept the fact that it can be an important component inside the engine, as this has been demonstrated by several different people who do not know each other and who live in different countries around the world. Second, having accepted that fact, the next step is to ask what exactly happens with the water.

I have come across an interesting document dated May 2009. I have been unable to trace its origin in order to ask permission to reproduce it here, so if you know how to contact the author, then please let me know. This is a report on an actual experimental tests on an internal combustion engine:

Ambient heat into work conversion.

Water-steam car, simple concept: simple Otto engine running from water mist using standard off-the-shelf ultrasonic humidifier (4 stroke diesel engine will work as well...could even perform better).



<http://home.howstuffworks.com/humidifier4.htm>

Replication log: Ultrasonic humidifier 0.25 liter water vaporisation per hour was set to 1/3 of its power. Use the water humidifier at air intake. Remove carburettor (or injection stuff if any) and filter for first. The way from duster to the engines air intake should be as short as possible to avoid the micro water droplets created by the humidifier collecting on the inside of the tube which feeds the water mist to the engine air intake. The engine used was a 1-cylinder 200 cc

electrical generator. The engine ran very slowly at first. In the case of a 4-stroke Otto engine, it is possible to speed it up using a propane cartridge. The engine then tends to "lock" into a higher rpm band, where the propane can be cut off permanently. The air going into the engine has a temperature of 22° C, while on average the air temperature leaving the engine was -16° C (a 38° C drop).

This is amazing – but this concept really does work!

You can make the car engine idle using this method. The water may need to be a bit warm. Ignition is not needed but it does facilitate the engine running. You may need to “turn the key” several times (based on this replication test). In the case of a diesel engine, you may need to replace the injectors with some kind of spark plug like on an A.E.R.O.P.S engine or use Firestorm plugs or any other stuff which is able to give the water an additional blast via plasma discharge, to increase performance further. You can make a gasoline generator work with water steam, also a lawn mower, etc.

Now – when it idles you have gone ‘over the edge’ so you need to add some more power, possible options are: adding hydrogen or HHO, preheating the water (possibly with solar energy), adding some fuel or spirit, powerful ignition or maybe some magnetic polarisation. This concept is now public and you can experiment with it on your own. Follow safety precautions and use common sense.

Do not expect high rpm results on the very first test run. Its a very basic concept which shows just **one** kind of transformation of environment heat into pressure and usable work. Also, do not pre-heat the engine before using it. The engine must not be hot!

A bit of physical background:

During the first stroke of a 4-stroke Otto engine, the piston moves down and sucks ambient air into the cylinder. During the second stroke, the piston moves up and compresses this air to a pressure of 25 bar (atmospheres). According to the “ideal gas law”:

$$p \times V = n \times R(m) \times T$$

the temperature rises due to compression above its initial ambient temperature. The compression ratio of the engine will boost the temperature, typically up to 450°C to 500°C. This second stroke of an Otto engine **NEEDS ENERGY FOR COMPRESSION!** Now consider what will happen to microscopic water droplets contained in the air inside the cylinder. If the water converts instantly to flash-steam, then its volume increases dramatically, boosting the pressure inside the cylinder and powering the piston during its power stroke and storing energy in the flywheel.

Please note, that the water mist isn’t water vapour...it’s not a gas! It is still a liquid! The **important DIFFERENCE** becomes evident during the compression stroke! As the piston starts to move upwards to compress air which contains the water droplets, pressure AND HEAT, as described before, start to rise. BUT the compression itself is NOT able to raise the water temperature directly, as the water is still a LIQUID and therefore the temperature of the water isn’t affected from higher pressure! So initially, only the air temperature rises due to compression. But tiny water droplets are present inside the cylinder, and as the air temperature gets greater and greater than the temperature of the water droplets, heat starts to flow from the air into the water droplets, heating them up! But as long the water temperature does not reach its boiling point, the droplets will not expand due to this rise in temperature and they will simply keep the same volume.

So the water droplets acting as a heat-absorber during the compression stroke! Lower heat implies lower pressure, and lower pressure during the compression stroke implies ENERGY SAVING DURING THE COMPRESSION STROKE!

Please have a look at the following graph (no losses are included in the calculation):

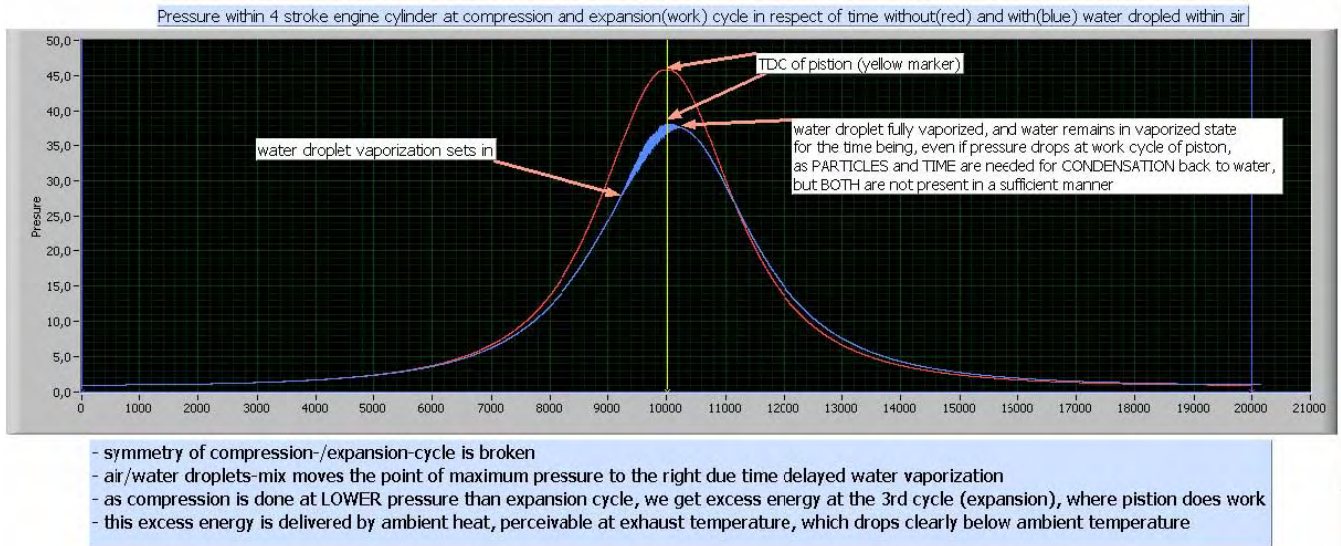

The graph shows the pressure within a 4-stroke engine cylinder in respect of time, starting from the beginning of the compression stroke (second one), ending with the end of the power stroke (third one). The work that is needed for the compression stroke is represented by the integral of the graph, from the very left to the yellow marker. The work which is done by the piston during the power stroke is represented by the integral of the graph from the yellow marker to the very right of the graph (20,000 at the time scale).

Let's assume that engine is an ideal one (loss-less). The red graph line represents the pressure within engine cylinder, if no water is present, and no ignition occurs. The graph is symmetrical to the Top Dead Centre (the yellow marker in the middle), so we put in energy at compression and we get the same amount back during the 3 stroke (power stroke). No loss, no gain. We get plus and minus zero.

The blue graph line shows what happens, if microscopic water droplets are present. The pressure does not rise as much as in case without water droplets, because the water works as a heat absorber during the compression stroke, and this lowers the pressure as well. The shape of the graph changes, so that symmetry of the compression and power strokes isn't there any longer, resulting in a gain of energy.

Factors which affect this process include the water droplet diameters, droplet distribution, the engine's rpm which controls the length of time, the ambient air temperature, the engine's compression ratio and even the water hardness and it's physical properties. It is certainly **not** a simple case where you can say "more water, means higher revs giving more power". For example, if the water droplets are too large, then there will be too little conversion to steam and insufficient power will be produced. Alternatively, if there are too few water droplets, then there may be no effect at all or the conversion to steam may take place too early to provide useful power.

The theory given here is a very simplified one, but should suffice for the first steps towards a better technology and a better understanding of the concepts of "energy from the environment".

It is tempting to conclude that the power gained from water droplets inside an engine cylinder are caused by the water turning into flash-steam and nothing else. However, that is probably not the case, nor is it the case that energy placed in the water by the sun heating it is extracted (which does happen) and that is the only additional source of energy.

In the scientific paper entitled "**Possibility of Liberating Solar Energy via Water Arc Explosions**" by George Hathaway and Peter Graneau, they discovered that when they produced an electric arc discharge in cold water fog: "The principal discovery made in the past two years was that it is a collection of fog droplets in the water which explodes and not the liquid water itself. The term 'fog' is meant to include not only the tiny droplets which float in air but also larger droplets which fall in the atmosphere and would be more correctly described as 'mist'.

The sole explanation of the explosions so far put forward contends that the intermolecular bonding energy in fog is less than 540 callg, the latent heat of bulk water. The bonding energy difference is then liberated in a quantum jump when the fog is formed in micro-seconds". Summing up their experiments, they conclude that "virtually all the kinetic energy developed by the explosion must be internal water energy"

In the earlier scientific paper "**The Anomalous Strength of Cold Fog Explosions Caused by High-Current Water Arcs**" by N. Graneau, he comments: "The unusual strength of explosions caused by a pulsed current flowing through water plasma was first noticed in 1907 by Trowbridge in his early high-voltage laboratory at Harvard University. When he passed an arc through a spray of water, the resulting explosion was louder than in ordinary laboratory air. During the Second World War, Früngel measured the strength of water arc explosions and published his results in 1948. He concluded that they were not caused by heat and steam and freely admitted that he was unable to explain the phenomenon. In 1969, the US Bureau of Mines issued a long report on their investigation into using water arc explosions for rock fragmentation. In one experiment, the investigators at the Twin City Mining Research Centre noticed that the energy output was apparently 156% of the input. This result was reported but treated as an experimental error".

The bottom line appears to be that using cold water mist droplets in an internal combustion engine has a minimum of the following energy additions:

1. Reduction of the energy required during the compression stroke due to the water droplets absorbing some of the heat generated by the compression and so reducing the increase in air volume during the compression.
2. On ignition, the very rapid conversion of the droplets to steam, caused by their massive surface area, produces a very rapid rise in pressure inside the cylinder.
3. The internal energy of the water caused by absorbing energy from the sun before entry into the engine may well be contributed to the power generation process.
4. Surprisingly, it has been shown that under these conditions, at the moment of explosion, the water itself contributes energy, and this process is one which most people are at a loss to explain, in spite of observing and measuring it happening.

The conclusion has to be that it appears possible that an internal combustion engine could be made to operate using cold water mist as the fuel, if a sufficiently powerful ignition plasma spark is provided using something like one of Robert Krupa's "FireStorm" spark plugs described below. Alternatively, with a lesser spark from an ordinary spark plug and the addition of quite a modest amount of a gas mix of hydrogen and oxygen from the electrolysis of water, the same effect can be produced. Consequently, although it appears so unlikely to a quick glance, that an internal combustion engine could be run on a mix of hydroxy gas, air and cold water mist, the reality is that the process is actually based on sound scientific principles and readily understood processes.

There is at the present time, a video of a car that runs effectively on just water, using aluminium plates:
http://www.youtube.com/watch?v=g_2tlnf6y_k.

5. Other Useful Devices

The Panacea series on improving engine running is highly recommended. You can view that information here:
<http://www.panacea-bocaf.org/fuelsaving-pollutionreduction.htm>

Ted Ewert's "Vortex" Air-Feed System.

Ted Ewert has developed and tested a very effective and simple device which can improve the running of some vehicles. This device works best with four-cylinder vehicles because the pulsed air intake of vehicles with fewer cylinders, enhances the beneficial effect.

This is a silent, simple and cheap device which enhances the airflow into the engine. This can have a dramatic effect on the performance of the engine. For example, Ted has an old Datsun 310 which has been sitting unused for years. Petrol ("gasoline") loses its lighter fractions in six months or so and that makes it far less volatile and more difficult to burn. Ted's Datsun has gasoline in the tank which is five years old and the car will not run on that fuel with its normal air intake. However, when Ted put one of his turbines on it, it starts immediately and runs fine with that old fuel. That particular vortex turbine has been dubbed "The Respirator". The Datsun has a carburettor which shows that this turbine works well with carburettors.



The “Respirator”

This simple device is a vortex tube made from a short piece of PVC pipe which has been slotted and shaped. It fits between the air filter and throttle body, or carburettor, and causes the incoming air to spin at a relatively high rate, creating a vortex. Angular velocity is crucial in the formation of a strong vortex and the air entering the Respirator from the air filter, arrives at right angles to the turbine slots, giving an immediate and powerful spin inside the tubing.

Ted says: “Most people think of a spinning air mass as having no particularly unusual properties. This is not correct. A spinning air mass has some very unique and useful properties. Standard aerodynamics, and linear Newtonian physics are unable to explain the properties of a flow of air spinning at high speed. In fact, when compared to a static flow of air within a pipe, a vortex behaves in almost completely the opposite way.

All spinning objects, whether they are solid, liquid or gaseous, contain two opposing forces: centrifugal and centripetal. Centrifugal is the expanding force travelling away from the centre axis, and centripetal is the contracting force pulling in towards the centre. This concept of dual forces is key to understanding a vortex. “Modern” physics has decided that the centrifugal force doesn't exist and now refers to it as a ‘false’ or ‘phantom’ force. This illustrates how detached from the real world academia has become and why it has stagnated.

The combination of these two forces, acting together in a vortex, create some unique conditions. One of these conditions is a laminar configuration. Co-axial laminations form throughout the vortex, creating numerous layers of air spinning virtually independently of each other. These layers are separated by zones of extremely low, virtually zero, friction and this allows them to spin at different rates.

As the vortex spins faster, the two opposing forces become stronger. This further laminates the flow as well as compressing the layers. The low-friction zones allow the compressed central air mass an unimpeded pathway for it's axial flow through the pipe. This is the reverse of the flow conditions for a straight, non-coherent air mass which has a tendency to develop friction and resistance, due to turbulence, in direct proportion to its velocity through a pipe.

Spin rate determines the degree of air compression and the linear flow rate of the mass. The faster that the vortex spins, the more it does just what we want, which is to create a dense, compressed and fast-moving flow. This is why we take the flow of air from the air box and use its speed and direction (90 degrees) to initiate the spin in our tube. This is by far the simplest and most efficient way to get the air spinning fast. The properties of a vortex are increased in step with the angular velocity. Just as a top wobbles and falls when spun slowly, so a vortex will not exhibit any strong properties until spun really fast.

As you may know, an important part of supplying air to an engine is the ability to supply a lot of air in a short burst.

This turbine creates a spinning air mass which is uniquely able to supply this air due to its virtually frictionless laminar composition and pressure built up through compression. The vortex provides compressed, dense air to the cylinder, which takes significantly less energy to draw in due to its stored inertial energy, and its ability to move freely in the direction of its axis of rotation.

Between engine cycles, when air is not needed, the vortex continues to spin and build up additional pressure. This spinning air mass acts like a flywheel and stores energy which is put to use on the next intake stroke. A static air flow has no such stored energy and has to be accelerated by the engine intake stroke every time air is needed, thereby wasting energy. This flywheel property is key to understanding why the vortex works as well as it does. Unless the vortex is pulsed, or modulated, no extra energy can be developed.

In a multi-cylinder car the flow of air becomes so steady that no effect is produced with just the turbine because there is no pulsing in the airflow into the engine. The rapidly rotating air within the turbine acts as a flywheel. When it is pulsed by the cylinder on the intake stroke, force is applied to the vortex as air is sucked down the pipe and into the cylinder. As soon as the intake valve closes, the pulse ends, the air stops its linear movement, but increases its angular spin velocity. This is where the extra power is generated. While the intake valve is closed, the vortex continues to draw more air into the pipe, where it is accelerated and compressed, until the intake valve opens again.

Power cannot be accessed until the pulse ceases. In a steady flow this never happens. Force has to be alternately applied and relaxed. To help visualise this imagine a coil spring attached to a shaft. When a sharp pulse is applied to the shaft, the spring expands. Only when the pulse ceases, and the spring starts to contract does the power get translated into movement. This also applies to a flywheel. You can also see with the coiled spring that the pulse must be timed to coincide with the resonant frequency of the spring for the highest efficiency. Random pulses, or pulses that are badly timed, will not have nearly the effect that correctly timed pulses have.

The air turbine doesn't rely as much on resonance as it does on large, well spaced pulses. This is because the power of the pulse is huge in comparison to the inertia of the air. Resonance is essential for anything that has a fair amount of mass - solids or liquids. In the case of a multi-cylinder engine, the pulses become less distinct the greater the number of cylinders. A six-cylinder vehicle barely sees any gain from the turbine, and an eight-cylinder little to none. With this type of engine the vortex needs to be modulated to gain energy.

This enhancement can be done through manipulating the shape of the intake tube. A round tube gives no gain but if the tube is "egg shaped" it produces an alternate centripetal / centrifugal pulse which imparts extra energy to the vortex. Just as the Earth draws energy from its elliptical orbit, so in the same way, the vortex gains energy with each rotation it makes through an elliptical, or egg shaped tube.

I put a slice of a smaller diameter pipe along the inner top of my tube. This small addition accomplished a noticeable increase in performance for the unit in my car. A curve in the pipe will also act like an ellipse since the rotation is compressed on the inside of the curve and expanded around the outside. Another interesting thing with the turbine is that it works much better when the engine gets hot. I notice a large increase in power in my bike as soon as the engine gets hot. This is because the heat adds energy to the vortex, just like a hurricane travelling across warm water. The heat added by the intake tube adds velocity and compression to the vortex as it spins waiting for the intake valve to open".

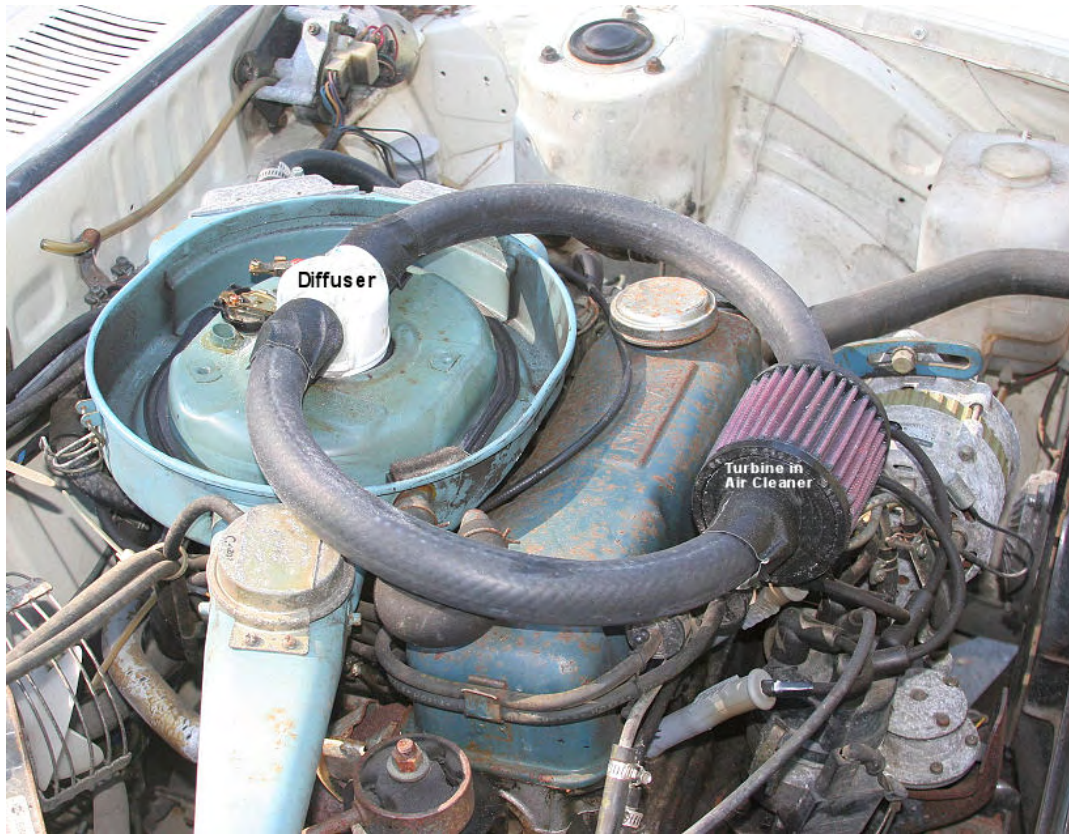

The vortex is created by cutting angled slots into a piece of PVC piping as shown here:

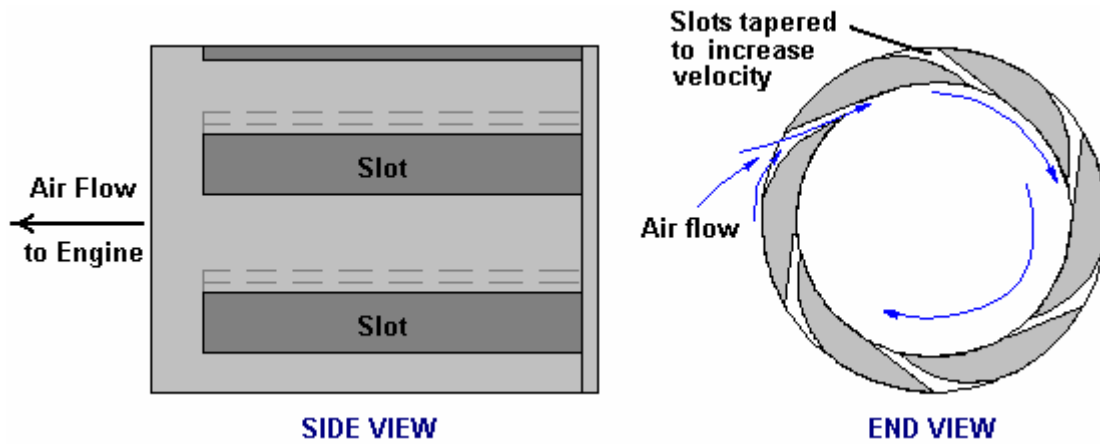

The air enters through each of six tapered slots cut parallel to the axis of the pipe. These give the air an initial spin inside the pipe and the pulsating intake of the engine, combined with the oval shape of the PVC exit T-piece, accelerates the air into a serious vortex which improves the intake to the engine, raising it's efficiency and giving more engine power.

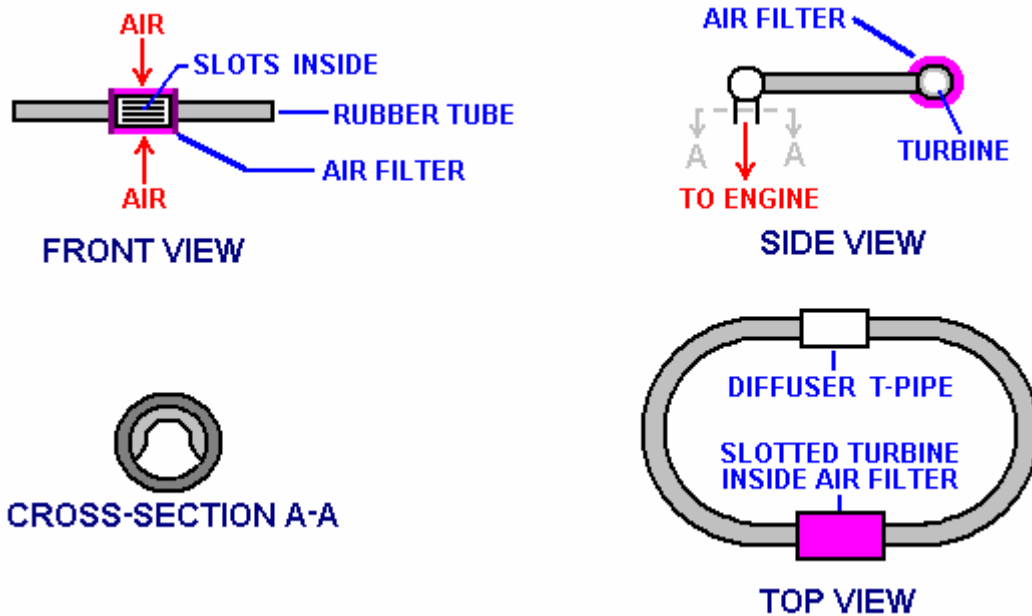

Ted created the egg-shaped part of the final PVC T-piece by adding an extra cut section of PVC pipe to a standard T-piece as shown here:



The turbine which Ted put on his bike works outstandingly well. The torque curve is extended well below its former efficiency range. It is possible to substantially enrich the fuel / air ratio and still maintain the same mpg results as before. When the turbine is removed, both the mpg and the engine performance go way down. The turbine adds more air to the engine. To take full advantage of the possible increase in performance, the mixture should be enriched.

Ted also put one in his 1995 Toyota Corolla car which has an 1800 cc 4 cylinder engine and a 5 speed gearbox and he is getting over 40 mpg on the open road and the low 30s around town. Originally, those figures were 34 on the open road and 27 around town. The performance has also increased very noticeably. Another nice feature is the lack of knocking and pinging under load. Performance in the mountains at high altitude is also significantly improved.

Ted has spent only a couple of months testing and evaluating this device on his cars and bike. A problem with this device is that it cannot be run directly through a carburettor, as it can with a fuel injection system. A carburettor works with a venturi which develops a low pressure zone in the throat with respect to the float bowl pressure. A vortex has no respect for a venturi and creates its own pressure gradient which screws up the fuel metering. Ted has somewhat solved this issue by diffusing the vortex just before it enters the carburettor. Pressure and velocity are built up before the carb then sent through a diffuser.

There is still plenty of research to do with this device. And there will be many improvements and beneficial modifications still to be made to it. Ted remarks that he does not have access to any engine test facilities and that makes it difficult for him to assess accurately the results of any design variations which he may make. Ted is hoping that someone will take his design and improve it further. There is great potential in this little piece of plastic pipe.

Ted has fitted a different style of his turbine to his Toyota as shown here. The turbine section is marked "PMT" which stands for "Poor Man's Turbo", though obviously, you don't need to be poor to benefit from a turbine system like this which has no moving parts:

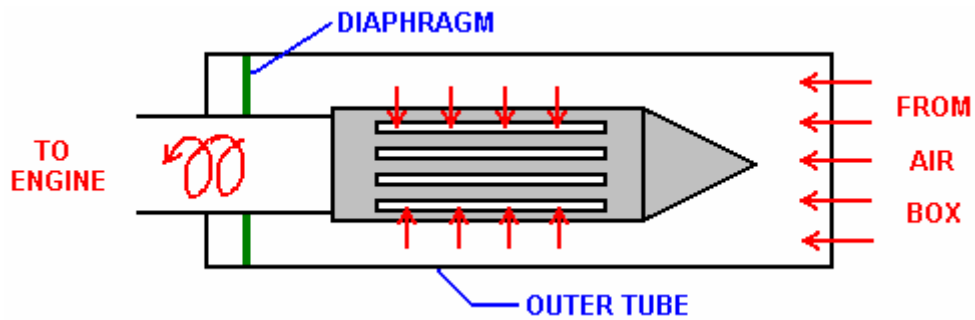

Cam-Timing Issues in America.

A deceptively simple way of improving mpg performance has been discussed recently in the watercar forums, and that is the adjustment of the cam settings on American cars made since 1971. This sounds most unlikely, but it is a proven fact. For example, a 2004 Jeep Wrangler 2.4 litre received a 10 degree advancement on both cams, and that gave a 70% improvement on the mpg, much more engine power and an exhaust which runs much cooler.

Over the years, one man experienced a 50% to 100% improvement in mpg over a range of personally owned cars and trucks, and the emissions were improved by nearly 90%. It is not suggested that everybody should make a cam adjustment, just to be aware that an adjustment of that nature can have a dramatic effect.

Another example: "Advancing the cam timing will make the engine run cooler. I have been messing with cam timing for about 25 years. I had a 1985 Ford Ranger with a 2.8 litre engine - it was a dog. The same engine used in the 1970 Mercury Capri had lots of power. The Ranger was a dog because the cam timing was set almost 10 degrees retarded. I gave it an 8 degree advance and the Ford Ranger came to life and hauled ass. Also, after-market ratio-rocker arms help a lot on late model cars. I changed the cam timing on my 1998 Chevy truck by 10

degrees. With it's 350 cubic inch engine and ratio rocker arms installed, it gained almost 90 horsepower and brought the power band lower giving more torque because the rocker makes the cam have higher lift and longer duration on the cam which makes it breath better."

Comment from a man with 25 years experience in this field: "Cam timing is when the valves open and close in relation to the crank shaft and piston movement. The number 1 piston is set at true Top Dead Centre. At this point the degree wheel is set to the front of the engine against the front pulley at the zero degrees mark and you install a pointer mounted to the engine block pointing at the zero mark on the wheel. When the crank is turned to about the 108 to 112 degree mark, the intake valve is fully opened. That is where most engines are set nowadays. This what I call retarded cam timing. The engine seems to run well but doesn't really to seem to have much low and mid-range pulling power. When racing, you would retard a cam for high RPMs, they also could breath and had no restriction in the exhaust. The power may come in at, lets say, 3000 - 6500 RPM and advancing a cam for more torque and power, that same cam may produce power at 1000 - 4000 RPM and after all, who drives over 4000 rpm on the road?"

Another comment: "Our jeep has twin overhead cams. Advancing them does not make them stay open longer, they just open and close sooner. My reason for advancing both cams was, if I only advance the intake cam, the intake would open earlier causing more overlap if the exhaust wasn't advanced. Normally the intake valve closes after Bottom Dead Centre. Just by looking at the piston, sometimes it's almost one quarter of the way up on the compressing stroke before the intake closes. By advancing the cams, the intake closes closer to BDC. This produces higher compression. Years ago, when I did this to some of the V8s, I would switch to adjustable rocker arms and a solid lifter cam. I was able to adjust the overlap by backing off on the rockers. On an engine with one cam, advancing the cam will adjust both the intake and the exhaust. Rule of thumb is: lets say most engines are retarded by 4 degrees or more, you really don't want to advance the cams more than 4 degrees advanced. I sometimes push this as far as 6 degrees advanced for improved mpg. That is a total difference of 10 degrees from 4 degrees retarded to 6 degrees advanced. This works well with low compression engines. I also don't see a need to go to a higher compression ratio. Think about it: if you had a compression ratio of 12 to 1 and the intake closes a quarter of the way up the compression stroke, how much is compression will there be, compared to a 8 to 1 compression ratio where the full stroke compresses the mixture? If you had a engine that made it easy to get to the cam or cams by just removing a dust cover, like on our Jeep 4-cylinder, I would say to install adjustable timing gears. Then you could just remove the cover and play with the cam timing until you came up with the best power and mileage

Robert Krupa's "FireStorm" Spark Plug.

The "FireStorm" plug was developed by Robert Krupa and it is an innocuous looking spark plug which can be used to replace a standard spark plug in an ordinary production engine:



However, this plug is far from ordinary. The central electrode has been changed from a cylindrical post to a hemispherical dome, surrounded by four arched electrodes, each of which being positioned at a constant distance from the hemisphere. This allows a much greater spark area and results in very much improved performance.

The fuel/air mixture can be made leaner without any harmful side effects. If this is done using standard plugs, then the engine will run at a much higher temperature which can damage the engine. But when using FireStorm plugs, a leaner fuel/air mix actually results in the engine running at a lower temperature. Robert has measured this effect and found that under identical running conditions, the engine exhaust was 100°F cooler when using FireStorm plugs. A mixture ratio of 24:1 is used rather than the current 14.7:1 mix and polluting emissions are very much reduced by the use of this plug design. Mixtures of up to 40:1 can be used with this plug.

Robert has been awarded two patents for this plug design: US 5,936,332 on 10th August 1999 and US 6,060,822 on 9th May 2000. These show variations of the basic dual arch electrodes, two of which are shown here:

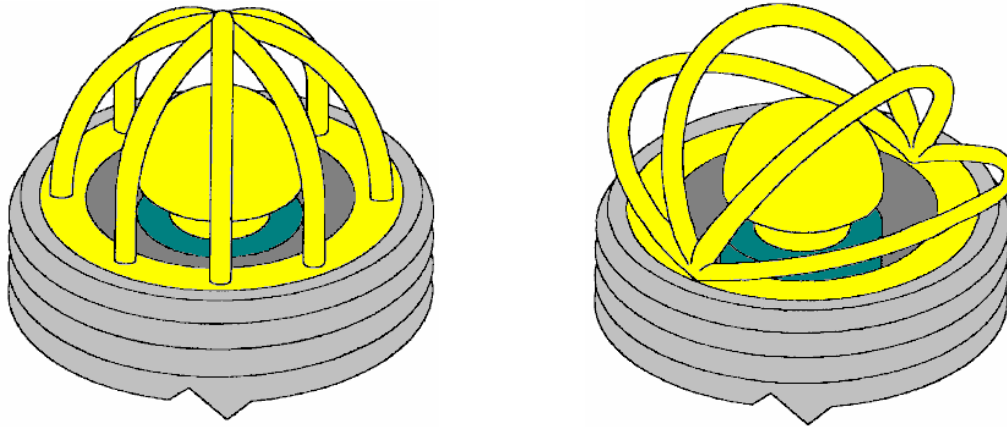

It was hoped that these plugs would go into production early in 2008 but there is no word of manufacturing starting. Robert gave Bosch of Germany a set of FireStorm plugs to test. After ten weeks of testing, their response was "This is unbelievable - we have never seen anything like this in all the time we have been building sparkplugs". When standard spark plugs fire for a long time, the spark gap increases and the spark is weakened. Bosch ran an eight-week endurance test on the FireStorm plugs and found that there was zero gap growth. They concluded that FireStorm plugs would never wear out (which may well be why they are not yet in production - after all, who wants to manufacture something which never wears out?).

Robert's first FireStorm plug was made in 1996 and he has encountered strong opposition to their introduction and manufacture ever since. This plug will not be popular with the oil companies as less fuel is burnt. This is probably a fallacy because, human nature being what it is, people are likely to keep spending the same amount on fuel and just drive more. For the same reason, the plug will not be popular with governments who tax fuel. The companies who make spark plugs will not like it as it does not wear out like standard plugs do. It uses less fuel and cuts harmful emissions dramatically, so it will be popular with motorists and environmentalists, if Robert can get it into production.

Plasma Ignition.

If any form of construction work with a vehicle is beyond your abilities, then the plasma ignition system offered through the <http://www.bluephoenixignition.com/products.htm> web site may be of interest to you. The company offers a system which can be used with any cheap non-resistor spark plugs and they claim a 40% improvement in mpg performance.



The video at <http://www.youtube.com/watch?v=gYCr4p5QDEA> explains the details of the system and claims that the resulting plasma from the plugs is so powerful that it can ignite cold water mist. Also, because of the very much improved fuel burn, the engine timing can be adjusted closer to the Top Dead Centre position, increasing the engine efficiency further. The very cheap spark plugs are liable to need replacing after five thousand miles or so, but that is hardly a serious overhead. The system can be used with 6-cylinder vehicles, 4-cylinder vehicles and electrical generators with one or two cylinders, and with outboard engines.

Roger Maynard's Water Vapour Injection System.

Fifty years ago car engines were not nearly as powerful as they are now. In those days it was quite common for a driver to remark that his car ran smoother and more powerfully on wet days. This was not imagination as water vapour drawn into the engine along with the air, turned to steam at the moment of ignition, and expanding provided additional thrust to the pistons while lowering the running temperature slightly.

This fact was utilised in World War II when units which were effective standard bubblers used with hydroxy boosters were added to the vehicles. Roger Maynard has built and used these units extensively since 1978, and my thanks goes to him for providing this information and illustrations.



The unit is attached to the air intake of the vehicle, between the air filter and the engine. A small diameter plastic pipe is lead from there to a glass or plastic container holding water. In the above picture Roger is using a glass Mason jar with a screw-on metal lid which has a seal. Sometimes called a preserving jar, these jars are very convenient.

The air feed into the jar is by a length of the same plastic piping and terminated with a standard air-stone or "soap-stone" as used in a home aquarium, as this causes a large number of separate bubbles. It is good practice to glue the plastic fittings to the lid of the jar, but this can make the jar too airtight and if that happens it may be necessary to remove the rubber seal which is around the neck of the jar.



A glass jar has the advantage of not being affected by the heat produced by the engine. This is a very simple unit and it uses ordinary water which is not exactly a hazardous substance. The effect of using it is far greater than would be imagined. On Roger's 4-cylinder KIA car, the mpg rose from 320 miles per tank full of fuel to 380 miles around town (18%) and 420 miles on the open road (31%) which is a very marked improvement. On his 6-cylinder Tacoma shows an 8% increase around town and a 12% increase on the open road. The water is topped up every 1200 miles or so.

However, some engines are suited to the air-stone and some are not. Smaller engines may work much better if a stainless steel screw is used instead of the air-stone:



Just to clarify the operation of the device:

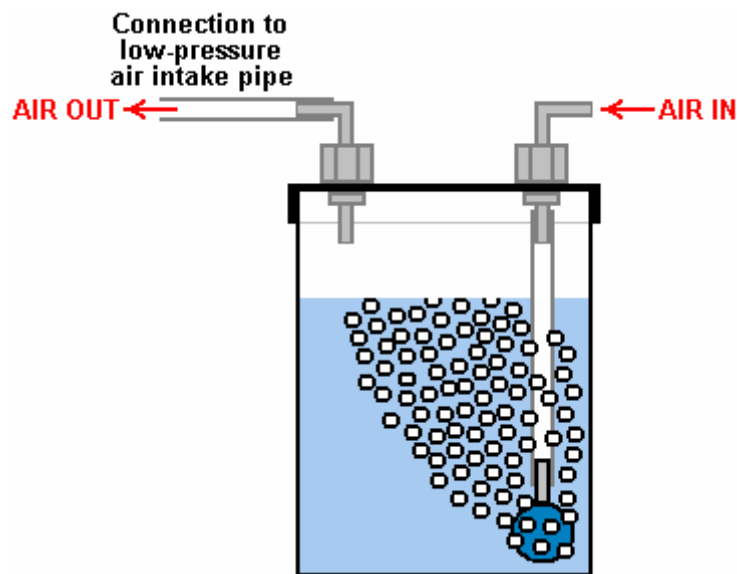

The container has a plastic elbow connection in the lid through which the outside air is drawn into the container. The air flows down through a plastic tube to either an air-stone from a pet shop, or a loose bolt in the end of the plastic tube. The air-stone has many small holes in it and these break the incoming air up into many streams of small bubbles.

There is a second elbow in the lid and the air, which is now very damp, is drawn out through it by the reduced pressure in the normal air intake of the engine. The lower pressure there is caused by the intake strokes of the engine and the air going to the engine now comes from two sources – the normal path through the air filter, and the new path through the bubbler. Most of the air flows through the air filter as normal, but there is now a small percentage which flows through the water, adding cold moisture to the airflow.

Some people feel that this couldn't possibly make any difference, but experience has shown that the addition of this extra stream of damp air can and usually does have a beneficial effect, improving the mpg, making the engine run a little cooler and generally improving the operation of the engine. It is a very simple low-tech device which does not cost much, so if you feel inclined, then try it out and see what effect it has on your vehicle, after all, if it does not provide a useful improvement, then you can easily remove it.

“Fuelsavers” Streamlining Fins.

A similar system used to be on offer from the website <http://www.fuelsaver.com.au/> where they offered small aluminium fins which mount on top of the trailing edge of the bodywork of a vehicle. The devices are reckoned to save some 10% to 12% on fuel consumption, they can be home-made, nine per vehicle is the recommended number. The device and mounting look like this:

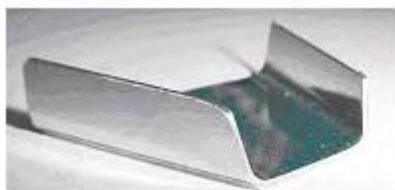

A "Fuelsaver"



The mounting method

Robert Patterson’s “Ram Implosion Wing” Streamlining System.

The next device may not be a “free-energy” device as such, but if not, it is very close to being such. It is a structure, which when mounted on top of a motor vehicle, improves the airflow to such an extent that the fuel consumption is said to be reduced by a major factor. The device was invented by Robert Patterson and is said to create a vortex which not only decreases wind resistance but may also create a forward propulsion force.

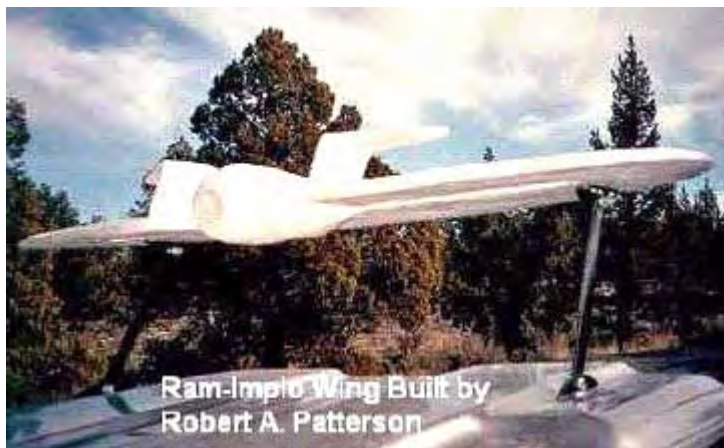

It is claimed that the effect created by one of these wings reduces the amount of dust stirred up when driving along a dirt road and if there is a paper bag sitting in the middle of the road, it is left unmoved when the vehicle passes over it at high speed. About a dozen people are testing this device at the present time. The biggest effect is at speeds of 60 mph or more. One researcher states that he installed the wing on the roof of his Lincoln Town car using a roof rack which allowed the wing to hang over the rear window by some six inches. He states that his fuel consumption has improved from 17 mpg to 56 mpg.

Positioning of the wing, texturing of the wing surface, and the speed of the vehicle appear to be important factors in gaining an improvement. There is a research group and the website is:

http://www.pureenergysystems.com/news/2005/03/08/6900067_RamWingUpdate/

High-mpg Carburettors.

The very poor mpg figures produced by most US vehicles is a quite deliberate arrangement forced on drivers by the oil companies. In 1997, an engineer working at a US Ford company plant witnessed a 351 CID V8 started at about 4:30 pm. with a 1 litre bottle of fuel as an exactly measured amount. The next morning when he went to the factory floor, that engine was still running and had only consumed about one third of the one litre bottle. On asking about the fuel consumption, he was shown a display that read, "248.92 mpg". He was shocked and said, "This must be a mistake" but the engineer said that it was true. He then asked when they would have it ready to be put in a new Ford, he was told that he would **not** see it in his lifetime. This is company policy and has nothing to do with engineering which is easily capable of this level of performance. That 249 miles per US gallon is 298 miles per European gallon since the European gallon is 20% bigger than the US gallon.

There have been more than 200 patents granted for high-mpg carburetors. These designs all give between 100 and 250 mpg on a US gallon of fuel. Not a single one of these designs has made it to the marketplace due to the fanatical opposition of the oil companies. Last year, the Shell oil company posted typical earnings for the year, which showed that they had made US \$3,000,000 profit **per hour** for every hour of every day of the entire year. Did you enjoy contributing to that profit every time you bought fuel to burn?

Nearly all of these high-mpg carburetor designs convert the fuel to vapour form before it enters the engine. There is no magic about this performance, just good engineering practice. It will probably come as a great surprise to you that the oil companies now put additives into the gasoline sold in the USA. They have 103 varieties of additives and I expect that they will explain that these are used to reduce evaporation in summer (as if they care about that !) and combat freezing in the winter. An “unfortunate” side effect of these additives is that they clog up any carburetor which converts the fuel to vapour form. Instead of 200 mpg, it is now quite common for US vehicles to have a 15 mpg performance and that effectively increases the cost per mile by more than ten times.

I am confident that it would be possible to design a high-mpg carburetor which deals with the additive sludge left over when the fuel is converted to vapour. In passing, the present situation gives added encouragement to stop burning oil-based products and switch to electric, compressed air, or water-powered vehicles. That is a perfectly viable option technically, but it would create frantic opposition from the oil companies and most governments which raise massive revenues from taxing oil products. The energy problem is not technical, it is financial and political.

Bob Boyce in America was handed a 3.5 year jail term for “running a vehicle on an unapproved fuel”. Bob was testing a car engine on HHO in his workshop behind his house and not on the road. Bob beat the charge in court. Since then, Bob has been told by the US Military that it is ok for him to build and use HHO boosters but he **must not** run a car on water alone. Guess who gives the US Military orders. Guess who does not care about the American people. A book on building your own high-mpg carburetor written by Larry D. Wagner can be downloaded from <http://www.free-energy-info.com/Wagner.pdf> but please be aware that thirty years has elapsed since it was written and gasoline in the USA is liable to be contaminated by additives which were not used thirty years ago and so, some variations may be needed. Wagner remarks that Pogue said that the new additives prevented him getting the same high mpg figures that he used to get.

In the Appendix, you will find eight out of the many high-mpg carburetor patents. The most famous of these are the three patents by Charles Pogue:

- www.free-energy-info.com/PatCarb1.pdf
- www.free-energy-info.com/PatCarb2.pdf
- www.free-energy-info.com/PatCarb3.pdf

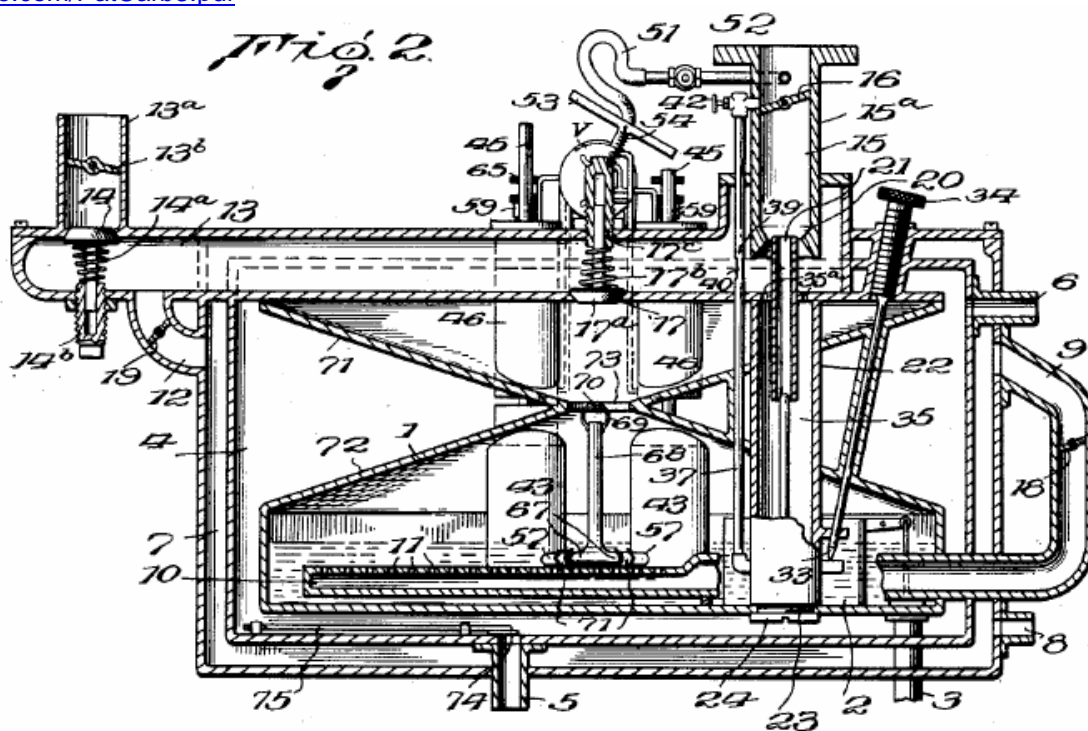

It would never have occurred to me that a carburetor could be used for anything other than feeding an engine, but a very experienced and practical man who lives in Alaska has used them for other things. He says:

I started out in 1976 when the first oil crunch came along and the Pogue system seemed to make the most sense at the time. We were looking to get a system started for making alcohol fuel and we were looking to develop a continuous-batch alcohol plant. This can produce feed for animals, fertilizer for the farms and fuel for vehicles or houses. It was based around growing barley and as barley is not good animal feed when grown, it needs to be cracked in some form and it was learned that this was a suitable method which had been used throughout Europe in ancient times. Two years later, the state passed a law banning alcohol fuel production. However, some of us wound up making heaters to use the alcohol produced in this way and those heaters were very efficient and they helped a lot of people, so something good did come of it anyway.

It was about this time that I met a man who had done research on the Pogue carburettor for the Sun oil company in 1928. He was very knowledgeable and helpful and in his 80's at the time. He agreed that going to alcohol, would be a better idea as it would solve many of the problems which had been engineered into gasoline fuels.

If you look at present day engines, they are as far as possible from what is needed for using this method. High compression engines will fire from heat generated under compression before top dead centre and will knock the top out of the pistons as it is an explosion rather than a burn. So, low compression engines are preferred, and firing at least 10 degrees after top dead centre. A long-stroke engine is best and some added flywheel weight increases the engine power. The incoming air needs to be pre-heated to reduce the amount of heat drawn from the combustion by the nitrogen in the air. It is the nitrogen heat content that suppresses the burn of any open fuel.

The GEET system is very similar to what we did with a few exceptions. We heated a small amount of fuel using an electric element, converting the fuel to vapour, pressurising it using the exhaust which made controlling the amount of vapour much easier. All the rest is basic GEET or Pogue.

There are many devices which I have made over the years, including the Pogue carburettor which can get very good energy efficiency from burning fuels. It is used by many industries from smelting furnaces to trains for transporting goods but it is not used by car manufacturers.

I like to study industry, because they use what works in the real world, even if they refuse to share the knowledge with others. Our group built a few metal smelters for cleaning aluminium and casting ingots. They use waste oil and roar like mad, smelting 50 lb engines in 15 minutes or less, burning less than a pint (half a litre) of oil to do it.

Allen Caggiano

If you think that this is exaggeration, take the case of Allen Caggiano whose high-mileage carburettor patent and constructional details are at www.free-energy-info.tuks.nl/Caggiano.pdf.



Allen is an inventive and stubborn man not readily blackmailed or browbeaten. In 1978 he produced the design for his first high-mileage carburettor, assembled the prototype and installed it in a 1973 Dodge Coronet station wagon. This gave spectacular results of 111 miles per gallon. Unfortunately, it failed after a short time. In 1979, he installed the second generation device on a 318 cubic inch (5.2 litre) Dodge V-8 engine and called it the "FIVS Gen II" standing for "Fuel Implosion Vaporisation System Generation 2". This second prototype proved very reliable and produced results as remarkable as the first, getting as much as 113 miles per US gallon (European gallons are 20% larger than US gallons so 113 miles per US gallon is 135 miles per European gallon).

The installation of the 'FIVS Gen II' required modifications to the carburettor and the removal of the catalytic converter. This was prohibited by EPA regulations. It was therefore a violation of Federal Law. Al ignored the

regulations because he knew tail pipe emissions from his FIVS vehicle were much lower than the law required. He was upholding the spirit of the law, and he was willing to argue his case in court if it came to that. He wanted a confrontation, he wanted a chance to tell the world that his FIVS made pollution control devices obsolete. He painted the station wagon bright yellow and in bold black letters along the sides he wrote: "This Car Gets Over 100 Miles Per Gallon and Doesn't Pollute the Air".

On the third day of his new campaign, as Al got into the station wagon he noticed a car pulling up behind him. He got out to greet two men in suits flashing FBI credentials. While he spoke to one, the other slipped away, climbed in to his station wagon, and drove it off. Astonished, he turned to watch his vehicle going down the street. Then he heard the FBI car pulling out behind him. Al just stood there watching the two vehicles disappear around the corner. An old friend, his attorney, later called the FBI office. The FBI denied any knowledge of the incident. Angry and frustrated, but undaunted, Al said good-bye to the Dodge Coronet, and found another similar Dodge station wagon and set to work installing another FIVS system. He painted this one yellow, too, with bold black lettering.

Not long after the first car was stolen, he received an interesting offer from a California based corporation. This corporation wanted to purchase exclusive rights to his FIVS Gen II. Al asked his attorney to check it out. The corporation turned out to be a subsidiary of several other corporations, all of which were owned by an oil company. This arrangement is typical of the way contemporary monopolies are structured. Al had been doing some reading about other inventors in the past and other fuel saving devices that had never seen the light of day and he was determined that he would never allow the oil companies get control of his device.

After he refused the offer, two different FBI agents came calling. He was careful not to leave keys in his unattended vehicle this time. They informed him that he was violating Federal laws and should cease and desist. Defiant and excited that he might soon make his case in court, he told his wife, Deb, not to worry. A couple of weeks after the second FBI visit, unmarked brown paper envelopes began arriving, containing 8" x 10" photographs of the children and Deb. A child on the playground at school. A child getting off the school bus. Deb in the supermarket, and so on. She was terrified and the marriage broke up.

The FBI was behaving like the Mafia. He wrote on the side of his Dodge: "The Big Boys Are Trying To Make Me And This Car Disappear! HELP ME!". One his oldest friends, his attorney, who was like a brother, refused to have anything else to do with him: "Wake up!" his attorney said, and then abruptly hung up the phone.

The Feds weren't going to give him his day in court to defend his FIVS. They had stolen his first prototype vehicle and they knew it worked as claimed. He had refused to relinquish his control, so they were going to send him to prison, but not for violating federal emissions regulations. On the face of it, the Environmental Protection Agency appears to be imposing regulations on the auto makers and the oil companies in the public interest of protecting the quality of the air we breath, and the quality of the air we breath is improved over what it used to be. But in fact, these special interests often write the legislation themselves. The regulations then create a profitable new area of business which allows the special interests to increase their control over the market. The public interest is best served by creative innovation in a free market. Al was learning Politics 101 the hard way. In the business of vehicles and oil, there IS no free market. In a monopoly-controlled market, there are anti-competitive regulations, dirty tricks, and active suppression. The Big Boys protected their turf and took control of or destroyed any potential competition in the hallowed tradition of John D. Rockefeller Snr. and the Robber Barons of the past. That wasn't hard to understand. But he was unprepared for the sophisticated tactics of today's faceless Robber Barons.

The Chief of Police for Brockton, planted stolen cocaine in Al's home during a drug raid that ultimately put Al in prison in 1986, for 15 years on a cocaine trafficking conviction, in spite of the fact that Al didn't use drugs, nor associate with those who did. He fought back. In prison, he fashioned a key in the prison shop and simply let himself out. He contacted a friend on the police force and then turned himself in on the same day. This police officer friend was able to uncover evidence of the chief's corruption. Two days later, the Chief was arrested for stealing cocaine from the evidence locker, most of which he had taken home to feed his addicted wife. He went to prison himself, which led to the reversal of over 300 drug convictions that had been decided during his tenure. The Massachusetts Supreme Court of Appeals overturned Al's conviction. For a moment, he thought he'd beaten the Big Boys and was a free man again.

But then the Federal Prosecutor stepped in and indicted him on new charges relating to the seizure of two shot guns during the phoney drug bust. A spurious interpretation of the US Code was applied. Al was sentenced to a total of 30 years in Allenwood Federal Prison, without parole.

Al's time in Allenwood was not wasted in self-pity or bitterness towards the Big Boys or the corrupted system that put him there. He was popular in Allenwood right away because of his role in exposing the dirty cop that overturned so many drug convictions. He developed a good relationship with the warden of facilities. As a licensed HVAC contractor, Al was able to fix the prison heating and cooling system that had never worked

properly, saving the government a large amount of money. Honeywell Corporation trained him in the use of computers so that he could operate and maintain the system. The prison had an excellent machine shop which allowed him to continue working with his FIVS devices. He designed small FIVS for the prison lawn mowers and produced numerous FIVS GEN II's, with the collaboration of the warden of facilities, that were secretly distributed outside.

Al made many useful contacts, one of whom helped him secure US Patent 5,782,225, awarded July 21, 1998, for the FIVS Gen II. He designed a new FIVS, the "Gen III", which did not violate any Federal regulations, and he put together a plan to manufacture and distribute the Gen III. And then one day he was out, free for real in 1997. Sentenced to 30 years without parole, he was suddenly released after ten years with five years parole. The Federal appeals court had finally ruled that his possession of two shotguns was legal and that it had no jurisdiction over the matter in the first place. Several years later, because he was curious, he asked a police officer friend to do a background check on him. No record of his conviction and incarceration in Allenwood was found. The stain of systemic corruption had been discretely removed.

He didn't look back and went to work to develop a prototype Gen III device, applied for his new patent, and implement the strategy he had dreamed up in prison. He was no longer politically naive, no longer the blindly patriotic American he'd once been. He did not believe it would be possible to build the Gen III in the home of the brave and the land of the free, so he made arrangements to manufacture parts in the Ukraine, a former satellite of the defunct Soviet Union. He would then assemble the devices in Mexico. He had developed a global perspective in Allenwood. His network of supporters and investors was now called: "FIVS Gen III International" and he set up a website which was generating 70,000 hits a month from all over the world. He also offered the complete blue prints for manufacturing the earlier FIVS Gen II as a free download from his site so that anyone who wanted to could build their own. He thought this might distract the Feds and tie up their manpower as he implemented the Gen III strategy.

By 2002, the delivery date for the first beta testing group was set. The parts were shipped from the Ukraine to Mexico where they were assembled. It was necessary for Al to travel South of the border to oversee the operation. He made the punishing drive from Massachusetts to Mexico several times in his FIVS equipped Pontiac Catalina and it functioned flawlessly, delivering more than 70 mpg with its 400 cubic inch engine. His friends warned him not to drive alone, but he made the last trip by himself and on the return leg of the journey, he noticed an 18-wheel truck following him. The intentions of this truck were soon obvious when it overtook him and forced him off the road. Al anticipated the manoeuvre, however, and was able keep control of the Pontiac. He breathed a sigh of relief and continued on, believing he'd outwitted them once again. He made it all the way to Massachusetts and was nearly home again before the truck found him a second time and caught him unawares. The Pontiac rolled over several times, but landed upright. The driver's side door was crushed and the roof caved in, but the car still ran and Al was able to drive it home without further incident in spite of his injuries. He had to be cut out of the car with a torch. He had several broken ribs and a punctured lung and was immediately rushed to hospital.

The Gen III's for the first group of licensees were shipped from Mexico on time, however, by means of several different shippers. Some devices for US licensees were shipped via United Parcel Service. A total of 137 units were shipped around the world. Only those that went UPS in the continental US and Canada, a total of 44 units, did not arrive at their destinations. Every shipped item has a tracking number, of course, and when Al inquired about the missing 44 units and provided the tracking numbers he'd been given, he was informed the numbers he had did not exist.

The attempt to turn him into road kill was not completely unexpected, but Al was shaken just the same. He maintained his bravado, however, while friends and sympathisers reacted more predictably. When the intent of the suppression escalated from malicious to deadly, most began to slip quietly away and it was 'High Noon' again. Another complicating and aggravating factor was the appearance of a discussion group at the Yahoo website called "Get 113to138mpgNOT". This Yahoo Group was established by an individual calling himself "David Rodale". He was not a Gen III licensee. He (or she) was a freelance public servant dedicated to helping those who had been ripped off by the promoter of impossibilities, the unscrupulous scoundrel, Allen Caggiano. He provided advice and counsel to those disappointed licensees who had not received their Gen III devices. He assured them that they could find justice in the courts. Al spent much time and energy fighting back against this defamation.

Al was fully recovered from his "accident" by this time and had repaired the Pontiac. He was feeling every day of his 59 years, but he soldiered on with a grim determination towards whatever final confrontation awaited him. When a careful, bloodless voice on the phone proposed a compromise one day, he felt ready to bargain. His website was experiencing growing traffic. The voice told him that if he would just remove the Gen III from his site he would be left alone. It felt like a small victory, but he didn't relish the idea of backing down. If Gary Cooper had received such an offer in High Noon, he would have taken it.

He knew a bargain with the devil could never work in his favour, but he had to catch his breath, so he played along and removed the Gen III from his web site. It was a strategic retreat. If they would leave him alone, the beta testing of units already out there could go forward. The program was smaller than he had originally intended, but it was a start and if he could relax and gather his data, then he might ultimately win the game. However, a careful examination of the FIVS in his Pontiac one afternoon made his heart jump into his throat. He found a tiny hairline crack in the aluminium/titanium alloy canister. This Gen III unit had many thousands of miles on it. It presaged a potential disaster and he immediately notified all the licensees of the problem and recalled the units. He worked feverishly and discovered that he didn't have to redesign the canister. A simple alteration appeared to be the solution.

Al was then told that he required immediate surgical treatment. After the fact, this prognosis was shown to be false. While the surgery was underway, Al suffered a stroke. His heart stopped and he was technically dead on the operating table. In addition, the surgeon had damaged nerves in his spinal column. It was not his time to go, however, and he revived, but then lay in a coma for 30 days. When he finally came around in his hospital room, feeling more dead than alive, he was astonished to discover that he could not move his legs. It is possible, that Al's medical experience was not accidental.

On the local TV noon news on a sunny day in the spring of 2003 he watched a dramatic live report of a SWAT team in action. They were closing in around a familiar looking building. He thought to himself: "Hey! That's looks like my condo! Hey! That IS my condo!". He watched the police seizing his yellow Pontiac in the parking lot as the Channel 7 reporter explained that Chelmsford, Massachusetts, resident, Allen Caggiano, had defrauded investors in a fuel saver scam and then fled the country. He didn't see how that could be true since he was in the Intensive Care ward of the local hospital, not 20 miles away.

Meanwhile "David Rodale" at Yahoo Group "Get 113to138mpgNOT" had found 20 disappointed Gen III licensees and was patiently building consensus for legal action at the state level in Massachusetts. It wasn't easy to turn disappointment into outrage and a desire for revenge. In spite of the resources available to the Big Boys, they hadn't been able to otherwise identify most of the testing program licensees. Al returned home to his condo to find his Pontiac with the repaired Gen III's in the trunk gone from its parking space. His premises had been ransacked, his computer hard drives removed. With his mind foggy from pain killers, Al tried to concentrate on getting used to a wheelchair. Nurses from the Visiting Nurses Association were with him around the clock. Gradually he stopped using the pain killers. He began to notice sensation returning to his legs.

Even as he felt himself improving, his diabetic condition inexplicably worsened. Twice he was rushed to the hospital in a comatose state. The third time this happened, a nurse checked his pill box and discovered insulin pills that should not have been there. He was now taking insulin through injection, but the old insulin pills were still in the medicine cabinet and had been put in his pill box with his other medications. The result was insulin shock. The nurse, Michele, who had done this, not once, but three times, did not again appear for her shift. Al tried to reach her to ask for an apology for her mistakes, but she had vanished. The Visiting Nurses Association denied having any record of her employment.

"David Rodale" was having success convincing the disappointed licensees to file suit, and with the newly acquired information about the FIVS Gen III International operations taken during the SWAT assault, a postal inspector launched a preliminary inquiry into the feasibility of action at the federal level for mail fraud. Rodale was confident that the threat to society posed by Allen Caggiano was now neutralised. He announced to the Yahoo Group members that he'd done his best and there was nothing more to do. He would leave the Yahoo Group in place for a while, but he planned to take it down in a couple of months. He was sorry that so many people had been taken in, and he hoped they'd be less gullible in the future. He was glad he could help.

That summer, the judge dismissed the charges against Al in the Massachusetts court. His lawyer petitioned for the return of his property, the Pontiac the local police had seized a year earlier. He was told it had been taken to Washington, DC, and was being examined to determine if it violated any Federal regulations. A grand jury in DC was convened to investigate the Federal charges of mail fraud, but it failed to return an indictment. The licensees who had paid their money and signed their licensing agreements had agreed to assume the risks of a testing program and most of them did understand that part of the risk involved the historical efforts of the oil/auto cartel to suppress new technology that could affect their profitability or control over the markets which they ruthlessly dominate.

Through his attorney, Al received an offer for exclusive rights to the Gen III. The amount of money involved beggars belief, and suffice it to say that Al again refused, as he had done in the early 80's when an offer was made for the Gen II device. The Big Boys have never attempted to prosecute him for the violation of Federal Emission Control regulations. He is clearly guilty on this score so far as the Gen II is concerned. To do so would result in the exposure of the fraud they are perpetrating on the public. Their technology is obsolete. As Al has pointed out on his website, they do not want a reduction in the demand for oil. This would mean a reduction in oil company profits. If the consumer used half or less of the oil now being used, government tax revenues would be

reduced accordingly. If the Gen III were to become available the public interest in fuel economy and clean air would be served and Allen Caggiano would become rich beyond wild imaginings, but the oil/energy cartel and its partner in government would suffer. Therefore, the Big Boys will continue to do all that they can to stop AI and his FIVS and to keep the public ignorant of any technology they do not themselves control. If they don't control it, and if you don't buy it from them, then it doesn't work, or it's a fraud.

The "FIVS Gen III International" enterprise has been successfully suppressed. AI's fight to manufacture and distribute his invention and enjoy the great wealth it would have given him is over. The Big Boys have broken his bank, and his health. The struggle has nearly destroyed him. The money would have been nice, but it never was the money that kept him going. He is now donating his work of a life time to the American people. The Big Boys can harass, intimidate, and attempt to kill one man and his American Dream, but can they do the same to many thousands of Americans and others around the world? AI now gives away his "FIVS Gen III" plans free.

AI will allow his patent application for the Gen III to expire. He can no longer afford the large investment required for a patent here and in other countries. His main concern now is to prevent the FIVS from being patented by anyone and to keep the device "open source", so to speak, so that it cannot come under the control of the Big Boys and will remain freely available to the public. Though AI will not profit from his invention through licensing fees or royalties, there is considerable satisfaction for him in knowing that the Big Boys have not and will not ultimately win this game and destroy the work of a lifetime.

Reference site: http://peswiki.com/index.php/OS:Caggiano%27s_Fuel_Vaporizer_System_%28FIVS%29

Forum: <http://groups.yahoo.com/group/fivsgenv> Patent: <http://www.free-energy-info.tuks.nl/US5782225>

Fuel Vapouriser Bubbler.

There is one technique originally from www.alternativefuelsnow.com and reproduced here by kind permission, which appears to be effective in spite of the additives. The method is very much like the technique used by Roger Maynard for adding moisture to the incoming air as described above. The difference is that instead of using water in the container, petrol is used. Improved performance of up to 60% has been achieved and experiments are continuing. The general arrangement is like this:

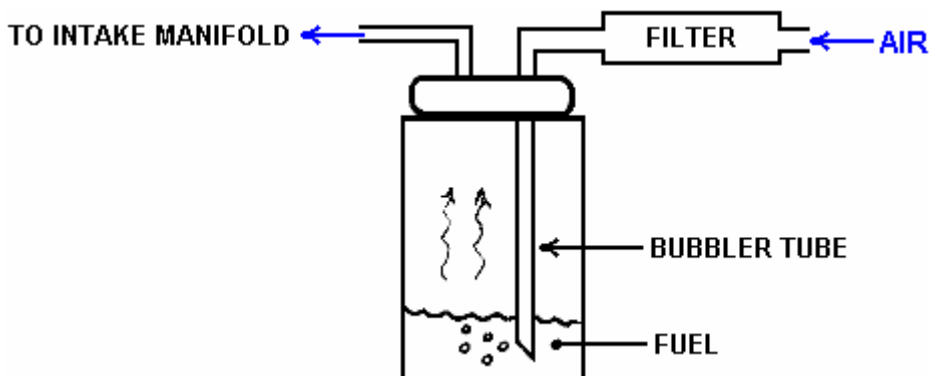



You will notice that the fuel level inside the container is kept fairly low in order to allow considerable space to contain the bubbles, allowing them to pop and not be drawn into the air tube which feed the engine.

Vortex Fuel Reforming.

This is a very important technology which has been around for more than a hundred years. The objective is to increase mpg not just by the vaporisation of the fuel but also by "cracking" the water / fuel mixture into smaller molecules before being fed into the engine. This is more advanced than the fuel 'conversion-to-vapour' technique of the high-mpg carburettors. To get a better understanding of this, you can try a Google search for "fuel reformer" or "steam reforming" which will provide additional information which may help you to understand the basic principles.

The fuel-reforming method can be highly effective and its effectiveness has been proven beyond all doubt with designs from Cal-Tech, Philips Petroleum, Nissan Motors, NASA, universities and other very serious contributors. Some years ago Cal-Tech spent millions proving that on board fuel reformers would give us all better fuel economy and cleaner air. They did long-term testing on buses and cars to provide proof. They teamed up with the very large auto-parts supplier Arvin Meritor to put them in production vehicles. Then "One Equity Partners" bought out Arvin Meritor's division that did all the final work to get fuel reformers in all our vehicles. They created a new company, EMCON Technologies, and that company dropped the fuel reformer from their product line, not because it did not work but because it did work.

There are various techniques for achieving this process. One which is easy to understand is shown here:

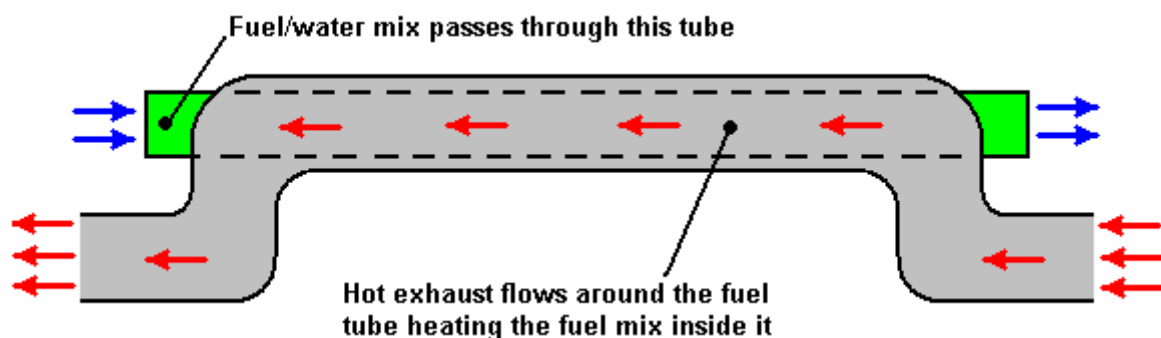

Here, the standard exhaust pipe is given a kink to move it clear of its normal run in order to allow an extra straight pipe of smaller diameter to be positioned inside it so that the hot exhaust gases are used to heat the incoming fuel

flow. This is a useful energy gain as it uses some of the waste heat, raising the overall efficiency of the engine very considerably.

This extra fuel-flow pipe has a solid magnetised ferromagnetic metal rod mounted inside it, blocking off most of the pipe area. This change in available flow area causes the fuel flow inside the pipe to speed up, and as well as that, it causes the flow to spiral around the rod in a vortex flow:

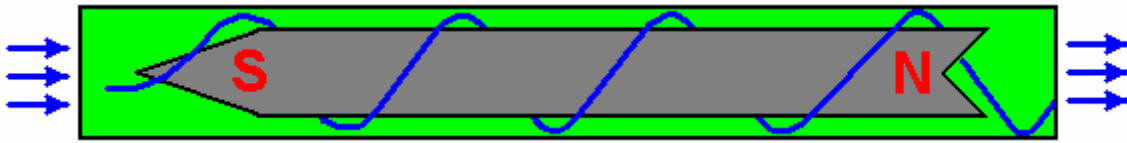

However, the magnetism of the solid rod, causes a most unusual effect and instead of the helical gas flow being as shown above, a highly uneven flow pattern is created. This causes the fuel flow to bunch up in the centre of the tube, generating a hot spot which creates quite unexpected results:

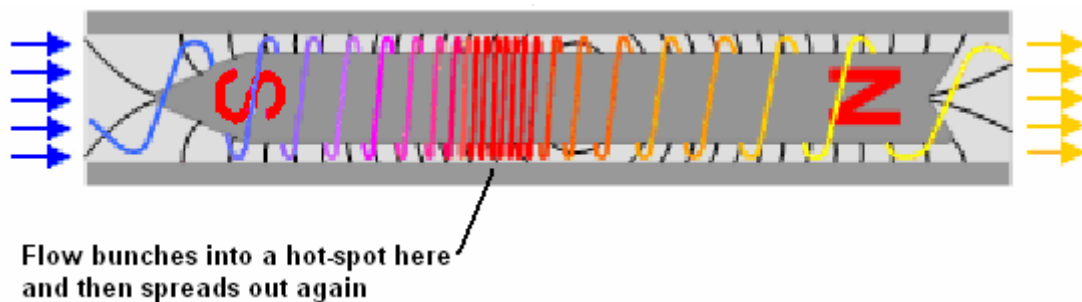

The really incredible result of this peculiar effect is that the fuel mix exiting from the tube, contains chemical components which did not enter the tube - impossible according to present day physics. This goes to demonstrate once again, that we really don't yet understand the world in which we live.

The fuel mix for use in this system is best provided by two tiny carburetors, one feeding a fine mist of water droplets and the other a fine mist of fuel droplets. These are fed directly into the intake of the fuel reformer tube. These carburetors are of the miniature type used for radio control model aircraft and their venturi intakes are blanked off with a plate with a small hole in it. Air is **not** fed into the reforming tube – after all, this is a fuel reforming system. The air is mixed in with the reformatted fuel after it exits from the reformer, as shown below. Some of the hot exhaust gas is fed into both of the carburetors in order to help prepare the mixture for the reformatting process. The blanking plates on the carburetors are there in order to reduce the amount of the exhaust gas being drawn in with the fuel:

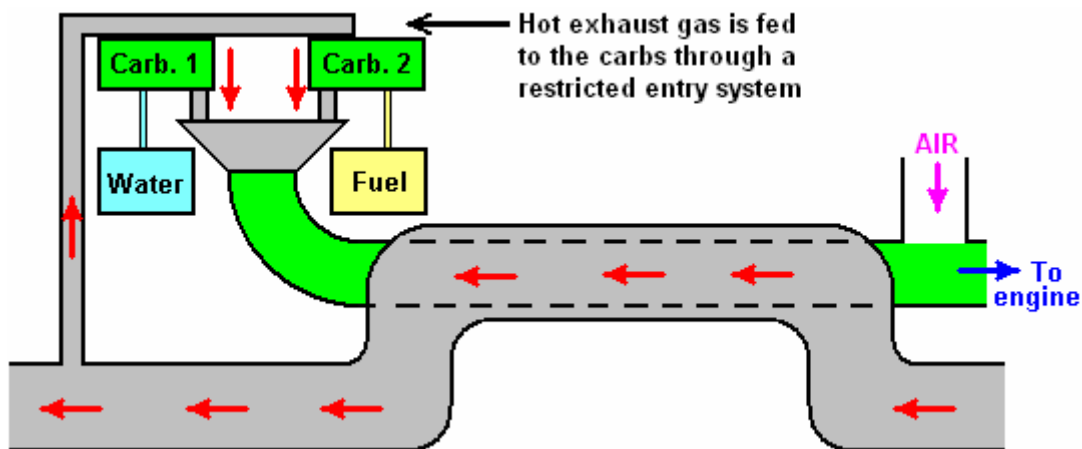

The use of carburetors is important since using a bubbler as suggested in the free plans on the internet, creates problems as the lighter fractions of the fuel get taken first which is exactly what we don't want to happen. The

carburetors have the massive advantage that they feed all fractions of the fuel together and so the remaining fuel is always in the correct proportions.

The ratio of water to fuel (typically gasoline or diesel) can be adjusted over a very wide range, with some people using 90% water. Actually, there have been claims of running on 100% water, using multiple reactors in parallel with energy being drawn either from transmutation of elements or perhaps spin interactions with the local environment. Jean Chambrin's patent give details of running only on water.

There are several forums where members are researching and using various designs of fuel reformers, with the GEET designs being popular. The <http://tech.groups.yahoo.com/group/VortexHeatExchanger/> forum is one such research forum and one of the files there lists 214 different patents for these devices. There are several different types of reformer. Another forum is <http://tech.groups.yahoo.com/group/geet-pantone/>.

Almost any hydrocarbon fuel can be used - vegetable oil, old motor oil, etc. the normal fuels are the most popular. A forum member named 'bryishere' says in a YouTube video comment: "Everyone should really try this. IT WORKS. I have spent a lot of time on this device. It's very simple. Just follow the plans and experiment as much as you can. Currently I am using 90% water and 10% crude oil/waste oil on a 1-ton, 1969 Chevy truck Get out in your shop !!!!!"

These devices are often used on stationary generators. These devices have been popular in France for some years now. Jean Chambrin found that the gases needed to swirl inside his reactor in the same direction that the crank was turning.

There is a massive 175 Mb file called 'FuelReformerTechnology.zip' which you can search for and download from the internet if you are very enthusiastic. That file contains the contents of more than 220 patents and applications. These patents are also listed in the 'Files' section of the Yahoo VortexHeatExchanger forum mentioned above.

Electric Power.

We have been talking about internal combustion engines as there are so many of them around the world, but electric power is an alternative. One hi-tech option is a Chinese SUV-style 5-seat saloon car which has a top speed of more than 120 mph, a range of 250 miles per charge and a re-charging time of just one hour, thanks to newly developed iron batteries which can be recharged up to 2000 times before they start to degrade. Also, these new vehicles look perfectly normal. I suspect that the cost of such a vehicle may prevent most people from buying one.



However, low-tech solutions can work well for some people. For example, Nader Hoville in Hawaii has adapted a truck for electric operation. He uses a battery bank of eighteen 8-volt Exide golf-cart batteries of 150 AHr each, giving a 144-volt 150 AHr bank. This provides a forty mile journey in fairly flat terrain and twenty-five mile range in hilly country and while that would not suit many people, it suits places like Hawaii where travel distances are not normally very great.

Running costs are lowered still further because Nader has a solar panel array of ten 250-watt panels which provide more than enough electricity for his house. As his solar system has larger capacity than is needed for household equipment, the additional capacity can be used to charge his truck's battery bank for free. Nader sometimes charges his truck's battery bank from the 120-volt AC mains when he is away from home, and to do this he uses an ultra-low-tech charging system which does not use a mains transformer. If, like Nadir, you are not familiar with electrical circuitry, then reading chapter 12 may help. The circuit is like this:

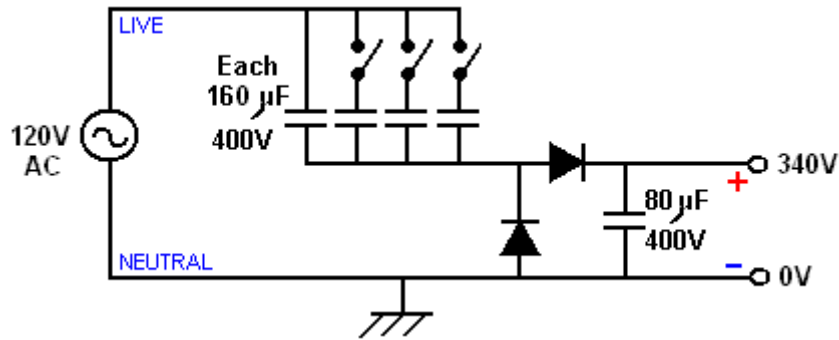

This is an unusual voltage-doubler circuit where the mains input has an average of 120 volts and a voltage peak of 170 volts and as that occurs on both sides of the output, the output is around 340 volts of pulsing DC current which both charges and de-sulphates the batteries.

The current fed to the battery bank is controlled by the capacitors inserted in the mains 'live' line. These capacitors have to be very high quality and typically cost US \$10 each. They look like this:



each of them being 80 microfarads in capacity and rated for 400-volt use. Nader uses these in pairs, giving 160 microfarads for each pair and each pair passes 133 watts of charging power to the battery bank. These are non-polarised capacitors (meaning that they don't have a Plus and a Minus side) and electrolytic capacitors will NOT do and are liable to explode if used in a circuit of this type.

The diodes are 40-amp 400-volt rated and they cost \$3.50 each. Please understand that this circuit has DANGEROUS voltages EVERYWHERE and those voltages can cause injury or death if you are careless. So please be warned, this is not a circuit where carelessness can be tolerated at any time. The charger is connected to the batteries BEFORE the mains supply is connected, and the mains disconnected before the charger is disconnected from the battery bank.

This is not a circuit which I see as particularly safe to use. You will notice that one of the terminals which you handle and connect to the battery bank is actually one side of the mains. I am not inclined to recommend that anyone handles mains wires. It is vitally important that it is the "Neutral" mains wire, which in theory is connected to ground and so is perfectly safe. However, in practice, that is by no means always the case and it has been known for the 'Neutral' mains wire to float 180 volts away from the earth voltage (which you are standing on!). So, I suggest that the "Neutral" wire is connected to a real, physical, earth connection and that mains power is not switched on while that connection is being handled.

Having said that, the circuit works very well for Nader, and is silent in operation. The charging power depends on the number of capacitors used and so switching in the extra pairs of capacitors gives the choice of charging at 133 watts, 266 watts, 399 watts or 532 watts. Nader's build looks like this:



The Weird Nature of Water and Advanced Electrolysis.

This chapter has been dealing with systems for enhancing vehicle operation with the use of water, so it seems appropriate to finish it with a brief note on water itself. To a casual glance, it appears that we know all about water. It's composition is H_2O and when it breaks down, we get two hydrogen atoms and one oxygen atom - right? Well maybe, and maybe not.

The longer you spend looking at systems which use water, the more you get to realise that water is by no means as simple as you might initially think. There is a much maligned branch of alternative medicine called "Homeopathy" which is based on giving patients very dilute water-based solutions various chemicals. Sceptical investigators have run professional-quality tests intended to show that homeopathy is fraudulent and has no medical benefits whatsoever. Unfortunately, the tests did not work out the way that the investigators wanted. The tests showed that there actually was some benefit from the treatments being examined, and unfortunately, because a placebo control group was being used, the placebo effect was definitely not the cause of the effects recorded during the trials.

Determined not to just accept the results which went against their expectations, the testers started testing ever more dilute samples on the patients. They eventually got down to the level where there no longer remained a single atom of the chemical in the liquid being fed to the patients, but to their consternation, the medical effect remained. They tried water which had never had the chemical in it, and there was no medical effect. They returned to the apparently "pure" and definitely chemical-free water and the medical effect was seen again, in spite of the fact that there was not even one atom of the chemical remaining in the water.

This showed clearly that the water was different after having had the chemical in it, even when no chemical remained. They were forced into the opinion that water has "memory". That, of course, is a conclusion based on the facts which are hard to explain. You may wish to deduce something else from those facts, and that is entirely up to you - just be aware of the facts.

Very interesting studies carried out by Mr Masaru Emoto <http://www.emotoproject.org/english/home.html> have shown that the thoughts of ordinary members of the public can alter the structure of water without there being any actual physical contact with the water. If the water receives positive thoughts and is then frozen, the resulting crystal structure will be like this:



While on the other hand, if negative thoughts are aimed at the water, whether just by looking at it and thinking, or by writing those thoughts down on paper, the resulting crystal shape is quite different when the water is frozen, as shown here:

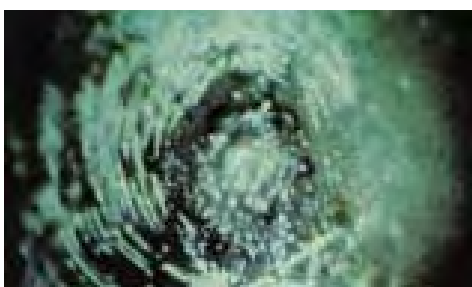

It is not all that startling if you consider that the quantum mechanics researchers have been saying for a long time that experiments can be affected by the observer. People who build Joe Cells which operate through environmental energy focused by specially treated and structured pure water, record the fact that certain people can affect a Joe Cell in a negative way from a distance of fifty yards (or metres) away.

Personally, I am quite sure that we do not understand the fundamental nature of our environment and that we have very little idea of how we as individuals impact on our surroundings.

There is an extremely honest and reputable researcher called George Wiseman who operates through his company Eagle-Research (<http://www.eagle-research.com/>). George is very experienced in producing "Brown's Gas" and he publishes excellent instruction books on the subject. The really interesting thing is that Brown's Gas is produced from water and that gas has the most remarkable properties which are not readily explained by our present day "conventional" science. When Brown's Gas is used as the gas to power a cutting torch (like an oxy-acetylene torch) the resulting flame is nearly colourless and can be waved across a bare hand without any ill effects - the hand is not burnt. But when applied to a fire brick which is intended to resist high temperatures, it burns a neat hole through it. It will vaporise a tungsten rod which normally takes 6,000°C to do that, which indicates that the flame temperature depends on what it touches (!).

It can also weld aluminium to aluminium without the need for an inert gas. It will weld aluminium to brass and it can weld a steel rod to an ordinary building brick. It can fuse glass to a building brick. This is not "normal" for a chemical combustion reaction, showing that Brown's Gas is not a "normal" chemical substance. As Brown's Gas comes from water, does that perhaps suggest that water is not a "normal" chemical substance? I will leave you to make up your own mind about that, perhaps helped by the following, most enlightening presentation by Moray B. King.

A Presentation by Moray B. King



Moray King has produced a substantial document covering many aspects of free-energy with special emphasis on the more unusual systems and some of the difficult-to-explain things which people have discovered. As Moray's presentation has 166 pages containing many pointers to video clips and specialist web sites, this is just a brief summary of his pdf document which can be seen in full here: <http://www.free-energy-info.com/MorayKing.pdf> and which has the uncommon feature of an icon at the top left hand corner of each page, and if you click on that icon, then additional comments can be seen. He starts with:

Steve Ryan, a man living in Auckland, New Zealand, who was shown running a motorcycle on modified water, shown on a cynical TV video presentation at <http://www.youtube.com/watch?v=POJQKg9CRJc> where the complete ignorance of the presenters is demonstrated yet again. Steve has disappeared from public view for a very long time now. However, Moray raises the most relevant question: "How can water store enough energy to make it appear to be a fuel?"



The first step in answering this question is to realise that causing cavitation (tiny stress bubbles) in the water inside an electrolyser, produces excess energy, and so, circulating the water inside an electrolyser while causing cavitation in the water is a major step forward, and one which seems to indicate that the majority of the energy in HHO gas does not actually come from the hydrogen. Instead, zero-point energy gets trapped in the water when the turbulence caused by the circulation, charges the water electrostatically, raising its energy content as it circulates repeatedly through the electrolyser.

Mark LeClair, the founder of the NanoSpire Corporation (<https://nanospireinc.com/>), discovered a microscopic crystalline form of water which has an extraordinary energy density. This crystalline form of water is similar to the microscopic plasmoids discovered by Ken Shoulders and the larger plasmoids discovered by Adamenko's team at the proton-21 laboratory in the Ukraine. When a plasmoid strikes any element, the result is transmutation of that element. The excessive energy and most unusual properties of Brown's Gas come from charged water gas clusters which are stored in a stable ring-form of the microscopic water crystals. This feature completely by-passes the standard electrolysis of water as examined by the great Michael Faraday where more energy is needed to split water than can be regained when the resulting gas mixture is burned. This is an entirely different process as explained at http://peswiki.com/index.php/Video:Water_as_Fuel_%28via_ZPE%29 in considerable detail on Sterling Allan's PESWiki web site, and it shows why water can indeed act as a fuel. If you search for "water fuel" on YouTube, more than 41,000 videos can be found, most of which are demonstrating electrolyzers, which shows that there is a growing awareness of the potential of water as a fuel. There are many commercial electrolyzers available.



Brown's Gas (HHO) has most unusual properties as demonstrated by Denny Klein's use of it in a welding torch as seen here: http://www.youtube.com/watch?v=6Rb_rDkwGnU and Denny has also run his car with water appearing to be the only fuel – the power comes from the zero-point energy field but that energy is transported by the water. Surprisingly, nearly everyone who is working with, or experimenting on the gas produced by electrolysis, believes that the resulting energy comes from the hydrogen in the gas mix, while the reality is that this is not actually the case. Brown's Gas has a cool flame of just 130 degrees Fahrenheit (water boils at 212 degrees Fahrenheit), and yet that same flame can vaporise tungsten which requires more than 10,000 degrees Fahrenheit and burning Hydrogen will never, ever, reach that temperature. Brown's Gas can also dramatically reduce radioactivity in radioactive materials and burning hydrogen can't do that. Also, when Brown's Gas is analysed in a high-tech laboratory, very little hydrogen is found and instead there are gaseous water clusters with excess electrons.

These charged water gas clusters have the same strange energetic effects that the plasma-charged have and that appears to be a microscopic form of ball lightning, studied extensively by Ken Shoulders who named them "Exotic Vacuum Objects" or "EVO" when he became convinced that their excess energy was being drawn in from the zero-point energy field of 'the vacuum'. These water gas clusters have a self-organised grouping of matter, plasma and zero-point energy. The typical grouping caused by this turbulent plasma is a vortex ring called a plasmoid (which has often been proposed as a model for ball lightning):



In a plasmoid, the electrons and ions spiral around the vortex ring and the force-free vortex creates a natural stability which sustains the plasmoid shape. These charge clusters can be produced quite easily as shown by Ken Shoulders in his US Patent 5,018,180 of 1991 where he shows that an abrupt electric discharge from a capacitor through a sharp pointed electrode on to a dielectric surface creates a charge cluster which travels on the surface of the dielectric to the anode. It appears to be a micron-sized form of ball lightning and it can punch a hole through the 'witness' plate, leaving a crater made by a high-energy event. The patent is well written and

describes many possible applications of his discovery.

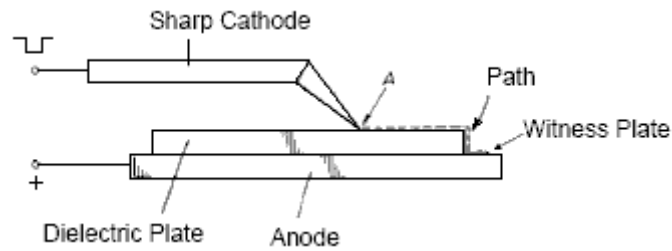

The Exotic Vacuum Object formed by this process is believed to contain 100,000,000,000 electrons plus some 100,000 ions, giving it a charge-to-mass ratio similar to an electron and a really interesting fact is that it contains more energy than the energy which was stored in the capacitor which created it. These charge clusters adhere to dielectrics and they can remain for a long time. Many of them can clump together into a formation like a necklace. They can create holes through high melting-point ceramics such as aluminium oxide. Ken believes that the creation of these holes in ceramics is caused by the disruption of the electrons in the ceramic and so the hole 'melted' through the ceramic is not actually produced by heat. He has performed experiments which demonstrate the transmutation of one element into another and others which show radioactive materials being converted into benign elements.

Water gas clusters have the same characteristics as Ken's Exotic Vacuum Objects and they cause the most unexpected effects of using Brown's Gas where the cool flame (266 degrees F) does not boil water (which needs 212 degrees F to boil) <http://www.watertorch.com/>, and yet, that same flame can vaporise Tungsten which requires 10,031 degrees F, mind you, the Brown's Gas flame does not vaporise Tungsten by heating it above 10,000 degrees Fahrenheit but instead, does it by disrupting the bonding of the molecules in the metal. Here are some comparisons:

Tungsten		
Melt	6192 F	3422 C
Vaporise	10031 F	5555 C
Browns Gas	266 F	130 C
Torches		
Acetylene	5972 F	3300 C
Hydrogen arc	7232 F	4000 C
Cyanogen	8477 F	4525 C
Dicyanacetylene	9009 F	4987 C

This heating can't possibly come from burning hydrogen. Some tests produce interesting results. For example, fill a balloon with the gas produced by electrolysis and leave the balloon sealed for some time. The tiny hydrogen atoms and molecules can, and do, escape through the material of the balloon, causing it to fall to the ground. But, the contents remaining in the balloon still produces a burning flame when pushed out through a small tube and lit. A similar experiment is to fill a paper bag with the gas. Seal the bag and leave it for twelve hours to allow the hydrogen to escape. What remains in the bag is a gas which is heavier than air and which can be ignited.

George Wiseman (<http://www.eagle-research.com/>) is a leading Brown's Gas researcher who has found that browns Gas burns downwards in an imploding ring. In 2008, Chris Eckman measured the characteristics of Brown's Gas at Idaho State University. The measurements showed that there was very little hydrogen (monatomic or diatomic) present. Instead, the gas was found to be a form of water with excess electrons, effectively, a gas which was neither water vapour nor steam. When ignited, the flame temperature was found to be 266 F. or 130 C. (*Extraordinary Technology*, vol 2(6), pp 15-25, 2008).

When using his acrylic electrolyzers, George Wiseman has made an observation which he says is never mentioned in any textbook describing electrolysis:

Wiseman: Middle Bubbles

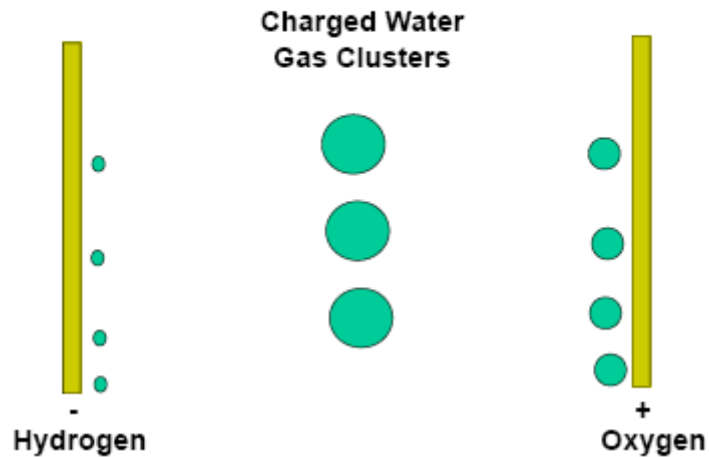

Between the electrolysis electrode plates which have a wide spacing of more than 10 mm, three sets of bubbles are produced. Hydrogen is produced on the negative electrode plate. Oxygen is produced on the Positive electrode plate. But, in the middle of the gap between those electrode plates a third set of bubbles are generated. Many researchers believe that these additional bubbles form the most energetic component of the gas – the charged water gas clusters. Bob Boyce has made a similar observation, noting that when electrolysis first starts, there are two jets which start from the plates and collide in between the plates where the middle bubbles are formed.

Bob Boyce: Two Colliding Jets

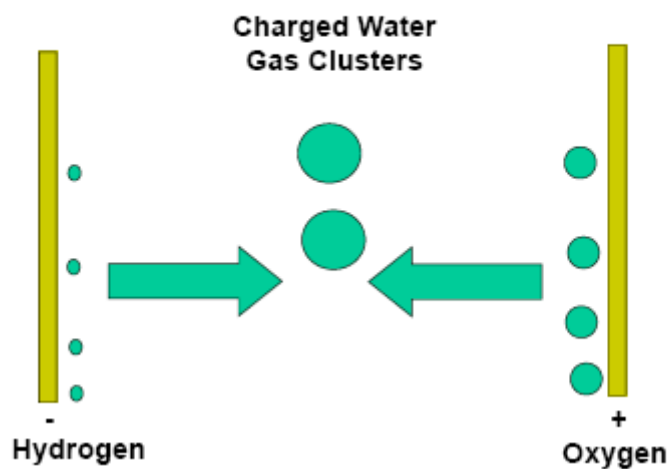

Ted Suartt and Rob Gourley (<http://www.wateriontechnologies.com/>) have not only made the same observation, but have developed a process and applied for a patent where they intentionally harvest just the middle set of bubbles:



Suartt & Gourley: Harvest Middle Bubbles

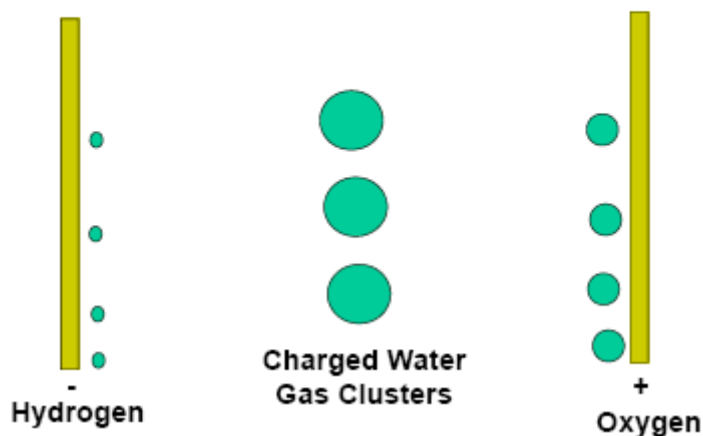

Suartt and Gourley realised that the dominant electrolyser gas was not Hydrogen, and claiming that they are the first to discover this, named the gas after themselves as “SG Gas”. Their extraction process involves widely separated electrode plates and a method of extracting the gas bubbles produced in the middle region between those two plates and excluding the hydrogen and the oxygen produced. They have investigated the properties of water infused with the gas and claim that it has health benefits. They state that Rhodes Gas and Brown’s Gas are both “dirty cocktails” which include H₂ or O₂.

The anomalies of Brown’s Gas are similar to those of plasma charge clusters (Ken Shoulders’ EVOs). It adheres to matter and is electrically polarised. It gives an electric shock if it implodes to form water again. The isolated gas tends to implode instead of explode in piston experiments. However, if air is added to the mixture, the air is heated and that can cause overall expansion. In a welding torch it has a cool flame but it can vaporise tungsten. The flame cuts cleanly through solid, high melting-point materials including wood and ceramics, can weld dissimilar metals together and can even weld steel to clay brick. The claims of neutralising radioactive materials as well as the transmutation of elements are extraordinary. Todd Knudston comments on these properties at <http://www.amasci.com/freenrg/hydroxy.html>. At the 2011 Tesla Conference, Vernon Roth announced that he has observed element transmutation in his electrolysis cell. Details of this are given on Sterling Allan’s web page at http://peswiki.com/index.php/OS:Vernon_Roth%27s_Alchemical_Hydrogen.

Mark LeClair can explain how water cavitation creates microscopic craters in metallic surfaces, carves trenches in high melting-point ceramics, transmutes elements, and produces excess energy. Cavitation bubbles have been studied and they have been shown to produce unexpected excess energy. Sonoluminescence occurs when water mixed with an inert gas such as argon or xenon, is excited by ultrasonic waves. A blue light is emitted as each bubble collapses suddenly and symmetrically. If that blue light were produced by a heating effect, then the bluish spectrum would indicate temperatures of over 10,000 degrees Kelvin, which caused many scientists to suggest that it might be used for hot fusion. Nobel laureate, Julian Schwinger, suggested instead that the light is caused by the zero-point energy. Here, the abrupt scalar compression of the bubble walls activates a Zero-Point Energy coherence, emitting the blue light at a far lower temperature (<http://en.wikipedia.org/wiki/Sonoluminescence>). Mark LeClair has four patents on controlled cavitation (typically for the precision cutting of materials): US 6,932,914, US 6,960,307, US 7,297,288 and US 7,517,430.

Controlled Cavitation

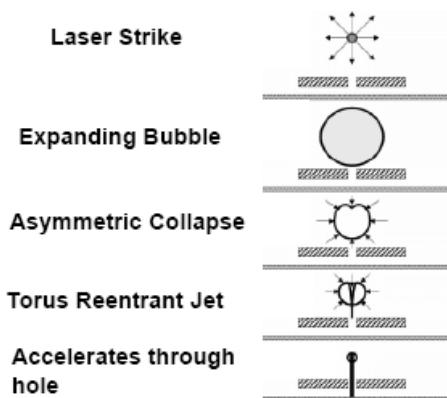

Target Cavitation

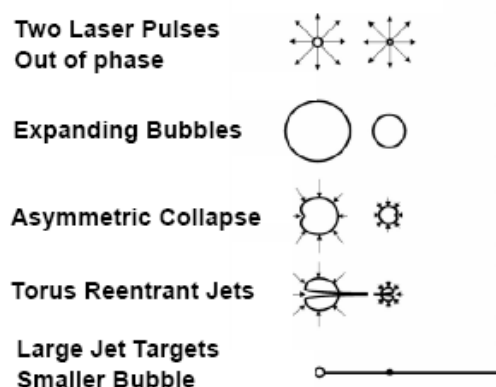

Cavitation bubbles form in the low-pressure region behind any rapidly moving surface in water. Ship's screws are notorious for making cavitation bubbles and being damaged by them:

Cavitation Erosion

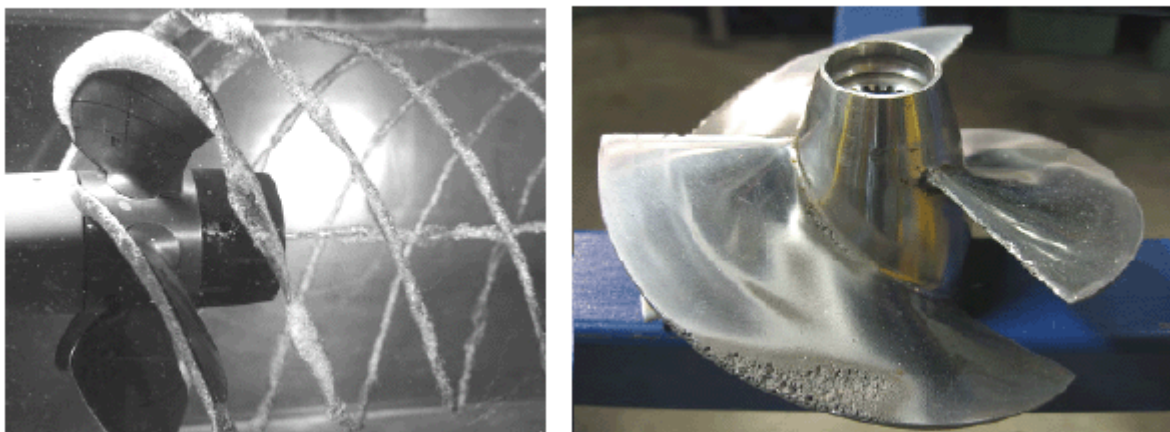

However, the most useful application of cavitation is inside an electrolyser. Archie Blue raised the effectiveness of his electrolyser by blowing air upwards through the electrolyte. The technique can be applied to many different electrolyser designs. The electrode plates should have a rough clean surface with a tiny inter-plate gap of less than one millimetre. A gap that small allows the electrolysis gas to cause cavitation. The electrical stimulation can use pulsed DC waveforms but with minimal current and electrolyte (remember that we are **not** trying to make hydrogen). Circulating the water rapidly can charge it electrostatically and possibly even enough to allow the removal of the external DC pulsing. There are many ways to produce cavitation in water: make electrolysis gas in narrow gaps, blow air through the electrolyser, create a Venturi vacuum, vibrate the water by mechanical, acoustical or ultrasonic means, oscillate an electric field via a toroidal coil or via pulsed waveforms. Here, charged or polarised clusters or bubbles will oscillate with the field causing turbulence and cavitation.

When a cavitation bubble collapses near a hole or irregularity, it forms a torus and all of the energy of the collapsing bubble gets concentrated into a re-entrant jet. The extreme pressure in the jet creates a new solid-state of water, a water crystal with a plasma bow shock wave which draws in Zero-Point Energy. If they collide, water crystals can form small rings, trapping the energy in a meta-stable torus form. This is the seed of the charge water gas cluster. When ignited, the ring breaks to re-launch the LeClair effect water crystal or alternatively, becomes a plasmoid Exotic Vacuum Object, either of which have excess energy.

Rapidly circulating water through an electrolyser causes numeric energetic effects. It charges the water by electrostatic rubbing, it causes turbulence and cavitation as it flows through the tight rough gaps, it can vibrate the plates producing reed cavitation and best of all, cycling the water repeatedly through the electrolyser integrates it's energy content, producing an ever increasing energy level. With water which is sufficiently charged, spraying it as a mist into the carburettor of an engine can give the illusion that water is a fuel.

This is just a brief summary of part of the contents of Moray King's presentation pdf document which you can read in full here: <http://www.free-energy-info.com/MorayKing.pdf>. Considering what Moray King has described, we need to consider more carefully the patented electrolyser designs of Charles Garrett and Archie Blue:

The Charles Garrett Electrolyser.

Charles Garrett was granted US Patent 2,006,676 on 2nd July 1935 in which he shows some impressive details. Firstly, he generated an extra electrical input by fitting a second (6 volt) alternator to his car. While the drawing shows the applied voltage swapping over in polarity, this was not done rapidly, just occasionally to even up any deterioration of the electrodes.

He maintained the water level in the electrolysis chamber with a neat carburettor-style float and pin valve arrangement. He improved the electrolysis by introducing a perforated tube below the electrode plates which allows the engine to suck air up past the plates. This cools the electrolyte (water with a few drops of hydrochloric acid) introduces water vapour to the gas mix and dislodges any bubbles on the plates, without the need for any extra mechanical device. Considering that he did this seventy-five years ago, it is an impressive piece of work. Please note that while only five electrode plates are shown in the diagram, in reality it is probable that many such plates were used since the gas volume is directly proportional to the plate area.

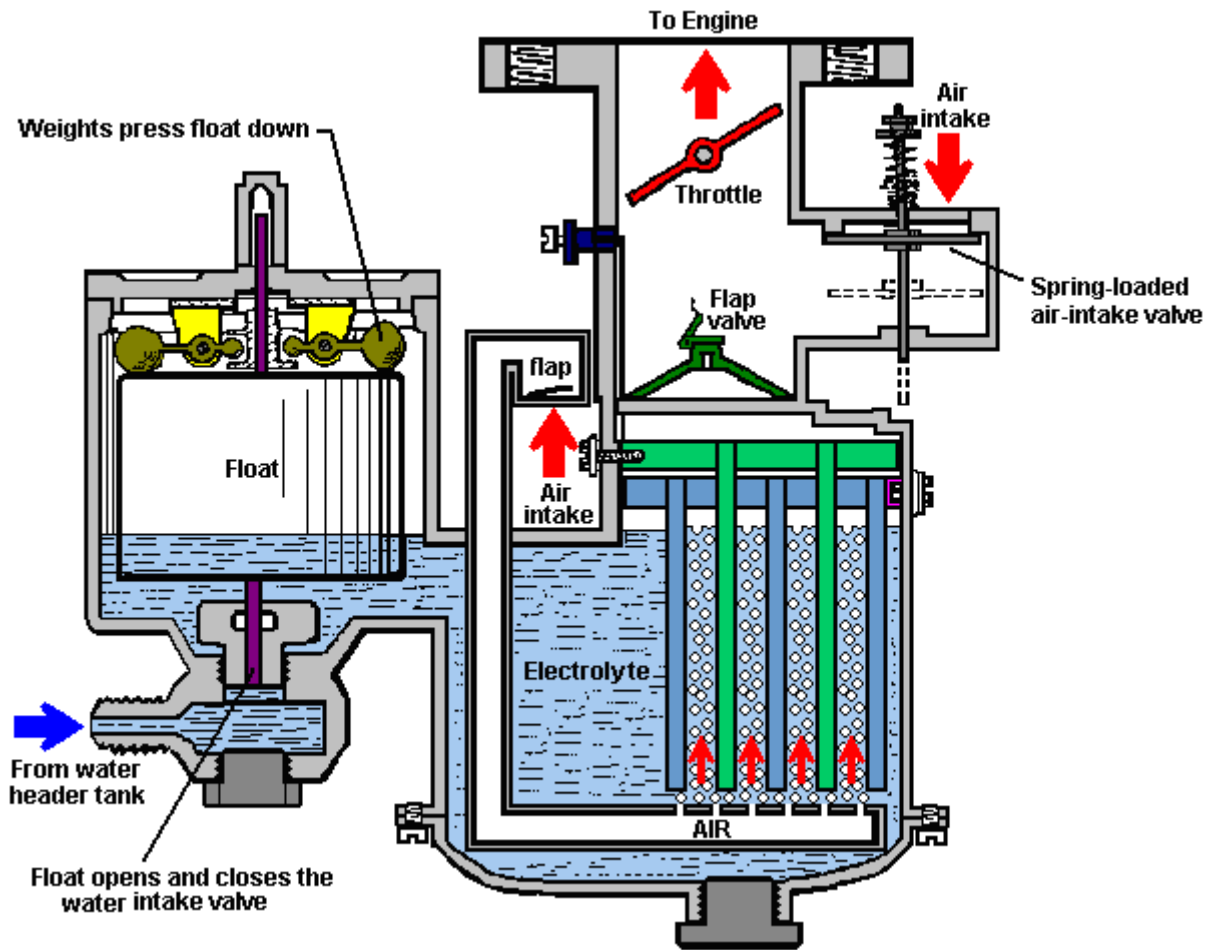

One point which should be noted is that the cars of that time had very much smaller capacity engines and so they will have needed far less HHO gas mixture in order to run adequately.



The Archie Blue Electrolyser.

More than fifty years after Charles Garrett was granted his patent, another one was granted to Archie Blue. The equipment described in the two patents operates in more or less the same way. Archie's equipment is very simple to construct and uses straight electrolysis with no attempt at pulsing the electrical supply. Like Charles Garrett, Archie Blue claimed to have run a car on water alone, using his electrolyser design, which is shown here:

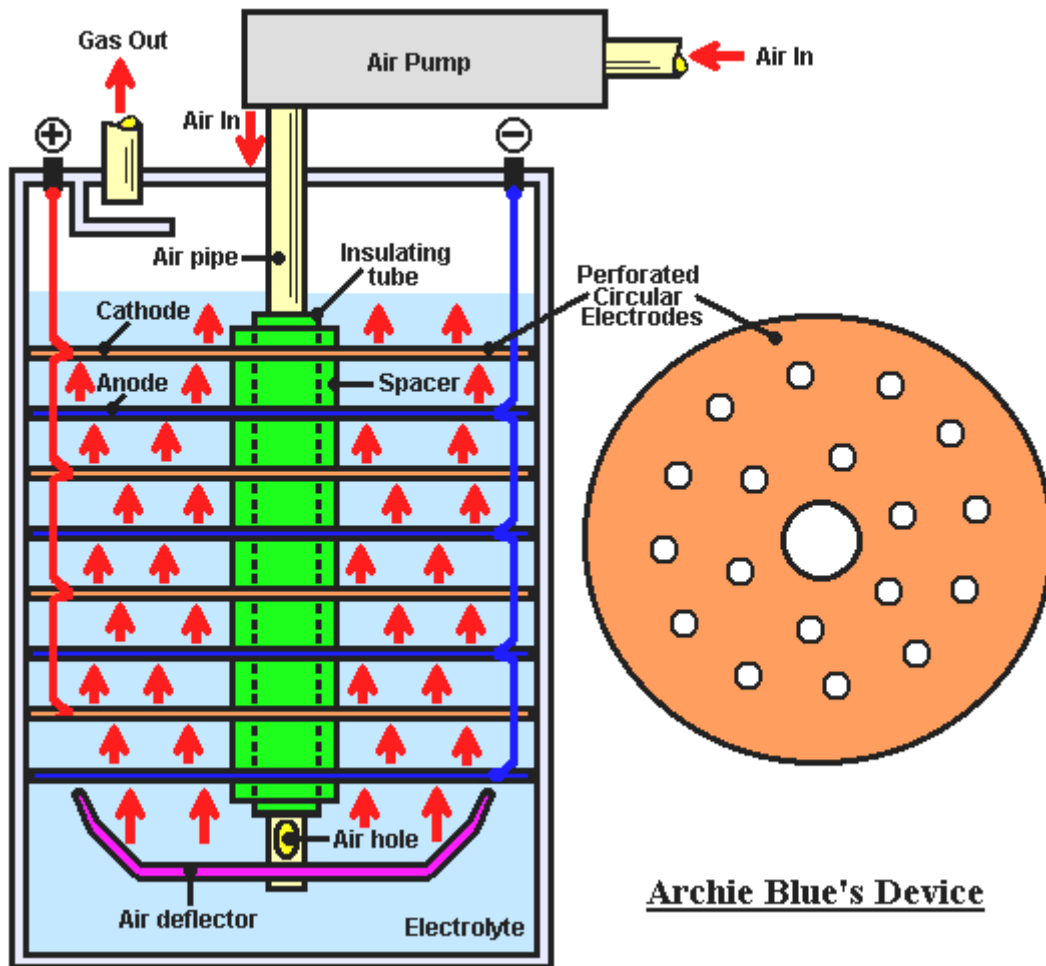

With this unit, air is sucked out of the exit pipe by the vehicle engine, while being pumped into the electrolyser by an air pump. The air flows down through the central pipe and is forced up through the non-aligned holes in the electrode plates, causing turbulence and probably, the formation of water-gas crystals. The air bubbles also stir the electrolyte into vigorous motion, dislodging the hydrogen and oxygen bubbles which form on the plates as a result of the electrolysis current flow through the electrolyte.

It is said that six of these electrolysis units are sufficient to run a car using just water as the fuel. It has been stated that electrolysis of water is optimum at 1.5 Volts, so it might be more efficient to connect the units in series where each unit receives 2 Volts rather than in parallel where each unit receives 12 Volts (unless, of course, the heating caused by connecting them in parallel is a factor in the very high efficiency of Archie Blue's system):

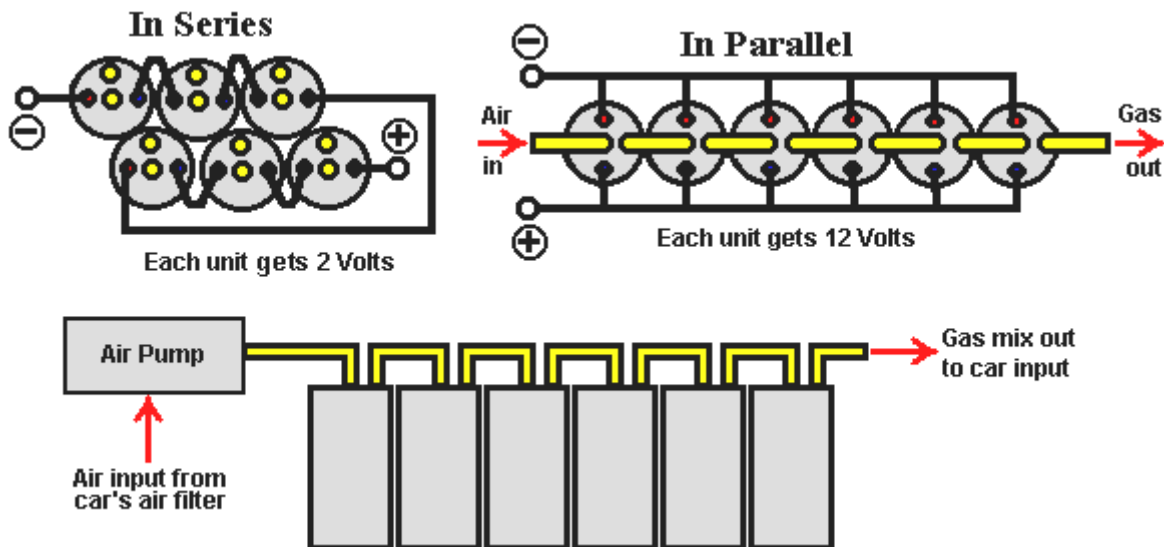

The air connection is the same for either method of wiring the cells. If wired in series, the voltage drop across each cell may not be the same although they were constructed in an identical fashion.

Please bear in mind that should you modify a vehicle to run on hydrogen, either as an additive or as a replacement for petrol, you need to clear it with your insurance company before using it on a public road, otherwise, you will be driving without insurance since any alteration to the vehicle automatically invalidates the insurance if the insurer is not notified and agrees the change. You may, of course, modify any stationary engine or any vehicle which you only run on private property. In the USA, the oil companies have influenced the local courts to such a degree that in some States, it is an offence to “run a vehicle on a non-approved fuel”.

In passing, you may be interested to hear that I have been told that the Prohibition era in America had nothing at all to do with people drinking alcohol. The reality was that in the early days, Henry Ford was going to have his Model-T car running fuel-less by using a Nikola Tesla designed magneto system and an electric engine, but he was pressured into using an internal combustion engine to burn the gasoline which was an unwanted component of the local oil industry. This caused a problem for people on long journeys as there were very few gasoline filling stations at that time. To overcome the problem, the early cars were set up so that they could run on either gasoline or on alcohol produced by some 50,000 farmers scattered around the country. When the oil industry discovered how profitable it was selling gasoline, they opened many gasoline filling stations. They then wanted to exclude the farmers and have all of the profits for themselves and so Prohibition was introduced, not to stop people drinking alcohol (although that was the pretext), but in reality, to shut down the 50,000 alcohol stills which were their competition. When the stills were gone, then Prohibition was dropped as it had achieved its goal of a vehicle fuel monopoly.

The Electrolyser System of Paul Zigouras

In his document, Moray King draws attention to the HHO cell design of the American, Paul Zigouras who became very well known in the year 2011 due to his cell design which is perfectly capable of running a 320 horsepower marine engine. Paul, at age thirty, had a history of rebuilding marine engines and then selling them. He then was involved in helping a friend who had entered a competition for the car with the highest mpg performance. Paul found that by adding HHO to the air entering the car engine, that they could get 70 mpg on the flat when driving carefully. Their target was 100 mpg, and so they were disappointed by being 30 mpg short of their target.

Paul decided to work on the HHO angle to see what could be achieved and enlisted the help of a friend and sometime freelance employee who was expert in electronics as Paul was not familiar with electronics. Probably without understanding the underlying causes, they managed to utilise several operating principles – cavitation, charged water gas clusters, resonance, mechanical vibration and a ‘splitting the positive’ style power supply. The overall result was spectacular, culminating in a small cell, into which water could literally be hosed and only gas came out of the other end.

Paul never revealed the exact circuit design and it is reported that he sold the rights to the design for US \$6,000,000. The purchasers then contacted the eBay buyer of the latest version of Paul’s circuit board and paid \$20,000 to buy it back. The eBay buyer was happy with the deal as he had paid just \$1,100 for it and so made a profit of \$18,900 on the deal. At this time of writing (2013) some eighteen months have gone by and it seems quite clear that the present owners of Paul’s circuit design have no intention whatsoever, of sharing or manufacturing the design and so it has been effectively shelved, never to be seen again. They were not interested in the cell, but just the electronics board.

However, a number of things are known about the design, probably sufficient to allow a similar design to be produced. These items are as follows:

Paul made units in two sizes. The smaller version had between 20 and 30 plates each being 2-inches (50 mm) wide and 8-inches (200 mm) long, material 316L-grade or 318L-grade stainless steel one sixteenth of an inch thick (1.6 mm), stacked with a gap of just 0.635 mm between them. This small version could blast 2.5 (US) gallons of water per minute into gas, which is about 17,500 litres of gas per minute. The water was hosed in at one end, and no water reached the far end, which is quite spectacular performance.

The larger cell had 36 plates 3-inches (75 mm) wide and 10-inches (254 mm) long, also 316L or 318L-grade stainless steel 1.6 mm thick and with a gap of 0.635 mm between the plates. That size of cell could convert water to gas at the rate of 5 (US) gallons per minute (35,000 litres of gas per minute)

The techniques used with these cells is nothing at all like any of the various other electrolyser designs discussed in this chapter. This is because the cell operation is nothing like conventional electrolysis or even like DC pulse driven water splitting as used in the Stan Meyer “Water Fuel Cell”

Firstly the plates are grit-blasted with 60-grade silicon carbide at an angle of 45 degrees to the face of the plate, making sharp-edged craters in the surface of the plate. When water is forced through the very narrow gap

between these plates, these craters on both sides of that very narrow water flow causes turbulence and cavitation. Cavitation produces tiny bubbles in the water and in the book "Ultrasonics Methods and Applications" by Jack Blitz, it is stated that each cavitation bubble has a positive charge on one side and a corresponding negative charge on the opposite side. As the bubbles are very small, those charges are not far apart and it would not seem to be unrealistic to suggest that those charges cause electrolysis of the water on a very tiny scale. But, as there is a very large number of these bubbles, the overall effect might not be insignificant. The violent cavitation almost certainly produces charged water gas clusters, so what comes out of the end of the cell will be HHO gas, charged water gas clusters, plus whatever gases which were dissolved in the water and possibly water vapour.

The plates were shaped like this:

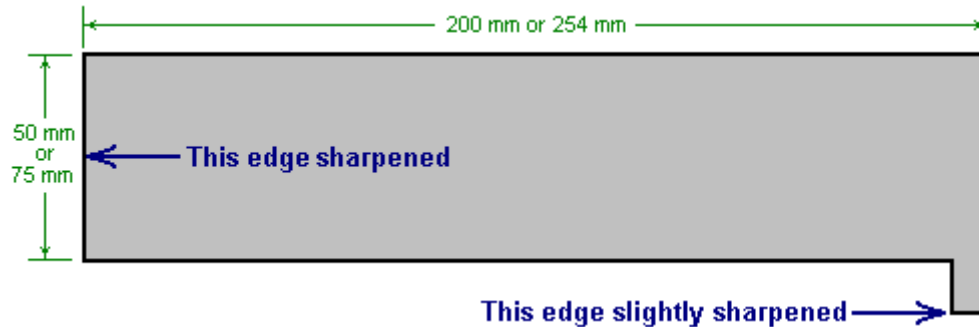

The edge facing the incoming water is sharpened to a knife edge, and the projection to take a push-on electrical spade connector has its outer edge slightly sharpened to make it easier to push the connector on to the plate and make a good electrical connection to the plate. Due to the very small gap between the plates, every second plate is turned over to give some clearance between the connectors. This places all of the positive connections on one side and all of the negative connections on the opposite side.

When being used to run a car, the HHO cell is placed inside the standard, rectangular, plastic air box which connects the air filter to the manifold air intake. This causes the incoming air to mix well with the HHO and other gases produced by the cell, before the mixture enters the engine.

The electronic circuit (valued at \$6,000,000) has an ordinary automotive power supply of around 14 volts. This is supplied by a standard MSD 200-amp high performance alternator driven by the engine. The initial current draw for the larger (35,000 lpm) cell is 190 amps, but when the cell gets going, that current draw drops to a constant 10 amps, and the gas production rate is **not** related to the current draw. This process is **not** any kind of conventional electrolysis and has nothing at all to do with Faraday's excellent lab work. The Coefficient of Performance is said to be between 5 and 10 although how that figure could be derived is by no means at all clear.

The circuit is said to produce a very clean square wave with very sharply rising and falling edges to the waveform. The frequency of the wave is in the 40 kHz to 44 kHz region and 30 separate transistors are used to drive the plates – presumably, one transistor per plate for the 30-plate version of the smaller cell. The waveform does not drop to zero volts, but instead, has a voltage offset of +1 volt. That is, the voltage oscillates between +1 volt and +14 volts and so there is always a voltage applied to the plates. As the circuit has never been disclosed, it is quite possible that the voltage is boosted well above the +14 volt level, however, that seems unlikely if 190 amps is the starting current. It is stated that at 44 kHz, the current needed is only one eighth of what would be expected for the HHO flow rate.

In a vehicle, the gas flow rate is controlled by improvising a linkage between the throttle and the valve which controls the rate of water flow into the cell. Not surprisingly, if the water inflow rate is cut down, the gas production rate has to fall also as there just isn't any water remaining to be converted into gas. Each litre of water produces around 1,860 litres of HHO gas, and so if the cell output is 17,500 lpm, then the water inflow rate would be about 9.4 litres per minute or 157 ccs per second. However, it seems unlikely that when mixed with air, as much as 17,500 litres of HHO would be needed per minute. It is remarked that using hot water just under boiling point, is an advantage, although why that should be is not specified.

The cell buzzes quite loudly when operating. This is definitely not caused by a 40 kHz frequency signal as human hearing only goes up to 20 kHz at most. It might be a lower harmonic (20 kHz, 10 kHz, 5 kHz,...) or it might be caused by mechanical forces generated by the water flow. If tap water is being used, then dissolved solids will be left behind when the water becomes gas. This residue can be washed out of the cell by turning the water on and keeping the electrical power off as that washes the plates.

With this amount of information on the cell and electronics design, it could well be possible to replicate the cell and run vehicle engines from it. However, please be aware that Bob Boyce in America was handed a 3.5 year jail term for “running a vehicle on an unapproved fuel”. He beat that charge, but it should be clearly understood that an action like that is wholly unlawful and is part of the scam which attempts to force all vehicle users to burn oil.

Also in America, Bill Williams was running his Ford pick-up truck with a Joe Cell connected as a booster in “shandy” mode. He found that his truck used no fuel at all even though it was perfectly capable of drawing fuel in from the fuel tank. Bill destroyed his cell and does not talk about it due to intimidation from armed thugs. Details of his design along with more advanced Joe Cell designs are in chapter 9.

The Petro Dollar

However, things did not stop there by any means. To discover more, perhaps you should consider the following video at <http://www.safeshare.tv/w/gQnBDHTCDs> which states:

Why did the United States attack Libya, Iraq, Afghanistan and Yemen? Why are US operatives helping to de-stabilise Syria? And why is the United States government so intent in taking down Iran, in spite of the fact that Iran has not attacked any country since 1798?

And, what's next? What are we headed for? When you look at the current trajectory that we are on, it doesn't make any sense at all if you evaluate it on what we are taught in school. And it doesn't make any sense if you base your world view on the propaganda that the mainstream media tries to pass off as news. But it makes perfect sense once you know the real motives of the powers that be. In order to understand those motives, we first have to take a look at history:

In 1945, Britain, with agreement, established the dollar as the world's Reserve Currency, which meant that international commodities were priced in dollars. The agreement, which gave the United States a distinct financial advantage was made under the condition that those dollars would remain redeemable for gold at a consistent rate of \$35 per ounce.



The United States *promised* not to print very much money but this was on the honour system because the Federal reserve refused to allow any audit or supervision of it's printing presses.



In the years leading up to 1970, expenditures in the Vietnam War made it clear to many countries that the US was printing far more money than it had in gold, and in response, they began to ask for their gold back. This, of course, set off a rapid decline in the value of the dollar. The situation climaxed in 1971, when France attempted to withdraw its gold and Nixon refused. On 15th August, he made the following announcement:

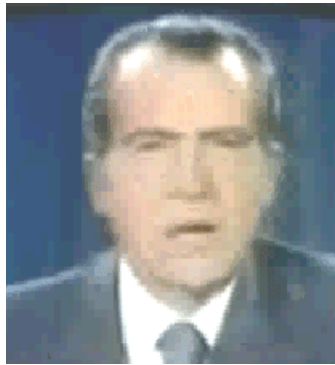

“I have directed the Secretary of the Treasury to take the action necessary to defend the dollar against the speculators. I directed Secretary Connolly to suspend temporarily, the convertibility of the dollar into gold or other reserve assets except in amounts and in conditions determined to be in the interests of monetary stability and in the best interests of the United States”.

This was obviously not a temporary suspension as he claimed, but rather a permanent default, and for the rest of the world who had entrusted the United States with their gold, it was outright theft. In 1973, President Nixon asked King Faisal of Saudi Arabia to accept only US dollars in payment for oil, and to invest any excess profits in





These sanctions which were initiated by Bush Senior, and sustained throughout the entire Clinton administration, lasted for over a decade and were estimated to have killed over five hundred thousand children. The Clinton administration was fully aware of these figures.



A TV interviewer speaking to Madeleine Albright, Secretary of State for Clinton, asked: "We have heard that half a million children have died, I mean, that's more children that died than in Hiroshima, and, and is the price worth it?". To which Madeleine Albright replied: "I think that this is a very hard choice. We think that the price is worth it".



Miss Albright, what exactly was worth killing 500,000 kids for? In November of 2000, Iraq began selling its oil exclusively in Euros. This was a direct attack on the dollar and on US financial dominance, and it wasn't going to be tolerated. In response, the US government with the assistance of the mainstream media, began to build up a mass propaganda campaign claiming that Iraq had weapons of mass destruction and was planning to use them. In 2003, the US invaded and once they had control of the country, oil sales were immediately switched back to dollars. This is particularly noticeable as switching back to the dollar meant a 15% to 20% loss in revenue due to the Euro's higher value. It doesn't make any sense at all unless you take the Petro Dollar into account.



On 2nd March 2007, US General Wesley Clark said: “So I came back to see him a few weeks later and by that time we were bombing in Afghanistan. I said: ‘Are we still going to war with Iraq?’ and he said ‘Oh it’s worse than that’. He said as he reached over on his desk and picked up a piece of paper and he said ‘I just got this down from upstairs (meaning from the Secretary of Defence’s Office) today, this is a memo which describes how we are going to take out seven countries in five years, starting off with Iraq and Syria, Lebanon, Libya, Somalia, Sudan and finishing off Iran”.



Let's take a look at the events of the past decade and see if you see a pattern. In Libya, Gadaffi was in a process of organising a block of African countries to create a gold-based currency called the “Dinar” which they intended to use to replace the dollar in that region. US and NATO forces helped to destabilise and topple the government in 2011 and after taking control of the region, US armed rebels executed Gadaffi in cold blood and immediately set up the Libyan Central Bank. Iran has been actively campaigning to pull oil sales off the dollar for some time now, and it has recently secured agreements to trade it's oil in exchange for gold. In response, the US government with mainstream media assistance has been attempting to build international support for military strikes on the pretext of preventing Iran from building a nuclear weapon. In the mean time they established sanctions which they openly admit are aimed at causing a collapse of the Iranian economy.

Syria is Iran's closest ally and they are bound by mutual defence agreements. The country is currently in the process of being destabilised with covert assistance from NATO and although Russia and China have warned the United States not to get involved, the White House has made statements in the past month indicating that they are considering military intervention. It should be clear that military intervention in Syria and Iran isn't being considered – it is a foregone conclusion. Just as it was in Iraq and Libya, the US is actively working to create the context which gives them the diplomatic cover to do what they have already planned. The motive for these invasions and covert actions becomes clear when we look at them in their full context and ‘connect the dots’. Those who control the United States understand that if even a few countries begin to sell their oil in another currency, it will set off a chain reaction and the dollar will collapse. They understand that there is absolutely nothing else holding up the value of the dollar at this point and so does the rest of the world. But instead of accepting the fact that the dollar is nearing the end of it's lifespan, the powers that be have made a calculated gambit. They have decided to use the brute force of the US military to crush each and every resistant State in the Middle East and Africa.

That in itself would be bad enough, but what you need to understand is that this is not going to end with Iran. China and Russia stated publicly and in no uncertain terms that they will not tolerate an attack on Iran or Syria. Iran is one of their key allies, one of the last independent oil-producers in the region, and they understand that if Iran falls, then they will have no way to escape the dollar without going to war. And yet, the United States is pushing forward in spite of the warnings. What we are witnessing here is a trajectory which leads straight to the unthinkable. It is a trajectory which was mapped out years ago in full awareness of the human consequences. But who was it that put us on this course? What kind of psychopath is willing to intentionally set off a global conflict which will lead to millions of deaths, just to protect the value of a paper currency? It obviously isn't the President. The decision to invade Syria, Libya and Iran was made long before Obama had risen to the national

spotlight, and yet, he is carrying out his duties just like the puppets who preceded him. So who is it that pulls the strings?

Often, the best answers to questions like this are found by asking another question "Cui Bono?" - "Who Benefits?" Obviously, those who have the power to print the dollar out of thin air have the most to lose if the dollar were to fall, and since 1913, that power has been held by the Federal Reserve. The Federal Reserve is a private entity owned by a conglomerate of the most powerful banks in the world and the men who control those banks are the ones who pull those strings. To them, this is just a game. Your life, and the lives of those you love are just pawns on their chessboard. And like a spoiled four-year-old who tips the board on to the floor when he starts to lose, the powers that be are willing to start World War Three to keep control of the global financial system.



Remember that when these wars extend and accelerate. Remember that when your son, or your neighbour's son comes back in a flag-draped coffin. Remember that when they point the finger at the new 'bogeymen' because the madmen who are running this show, will take this as far as you allow them to.

So, how much time do we have left? It's a question which I hear constantly. But it is the wrong question. Asking how much time we have left is a passive posture. It is the attitude of a prisoner who is waiting to be taken out to a ditch and shot in the back of the head.

What are our chances? Can we change course? Also, the wrong question. The odds don't matter any more. If you understand what we are facing, then you have a moral responsibility to do everything in your power to alter the course we are on, regardless of the odds. It is only when you stop basing your involvement on the chances of your success, that success actually becomes possible. To strip the ill-begotten power from the financial elites and bring these criminal cartels to justice, will require nothing less than a revolution. The government is not going to save us. The government is completely infiltrated and corrupt to the core. Looking to them for a solution at this point is utterly naive.

There are three stages of revolution and they are sequential. Stage One is already underway Stage One is the ideological resistance. In this stage we have to actively work to wake up as many people as possible about what is happening and the direction we are headed. All revolutions originate from a shift in the mind-set of the population and no other meaningful resistance is possible without it. Success in this stage of the game can be measured by the contagion of ideas. When idea reaches critical mass, it begins to spread on its own and seeps into all levels of society. In order to achieve that contagion, we need more people in this fight. We need more people speaking up, making videos, writing articles, getting this information on to the national and international stage, and we especially need to reach the police and the military.

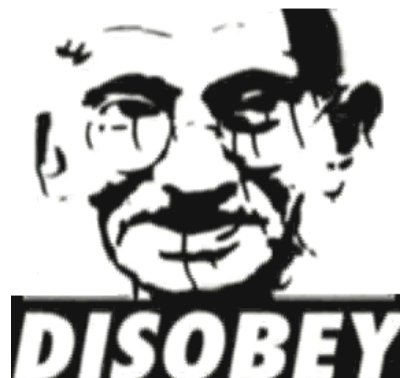

Stage Two is civil disobedience, also known as Non-violent Resistance. In this Stage, you put your money where your mouth is, or more accurately, you withhold your money and your obedience from the government and you do

everything in your power to bring the gears of the State to a halt. Practiced in mass, this method alone is often enough to bring a regime to it's knees. However, if it fails at this stage, Stage Three is inevitable.

Stage Three is direct physical resistance. Direct physical resistance is the last resort and it should be avoided and delayed as long as possible and only invoked when all other options have been thoroughly exhausted. There are those who 'talk tough' and claim that they will resist when the time comes, but what they fail to realise is that if you are inactive during the first two Stages and save your efforts for the last resistance, then you will fail.



When the Nazis were moving from door to door, dragging people out of their homes in Germany, that was the time to fight back physically, but due to the lack of ideological resistance and civil disobedience leading up to that moment, even an armed uprising would have likely failed at that point. An armed uprising can only succeed if the people have established an attitude of active resistance. And active resistance is only possible after their minds have broken free from the mainstream propaganda. If you want to fight back, then it's now or never – you're not going to get another chance, and the stakes are far higher than they were in Nazi Germany.

If you want to know more about the present situation, then watch the very informative web video at <http://www.youtube.com/user/ThriveMovement>, which also shows what you can do to improve things.

Patrick Kelly

<http://www.free-energy-info.tuks.nl/>

Chapter 11: Other Devices and Theories

Nikola Tesla's Ionised-Air Electrical Generator.

Tesla also designed a device for picking up energy from the air. As far as I am aware, it was never patented and I have never seen a specification of its output. Perhaps it was one of Tesla's failures but personally, I doubt that. It might make a very interesting experiment so see what level of output can be achieved using it. The construction is shown here:

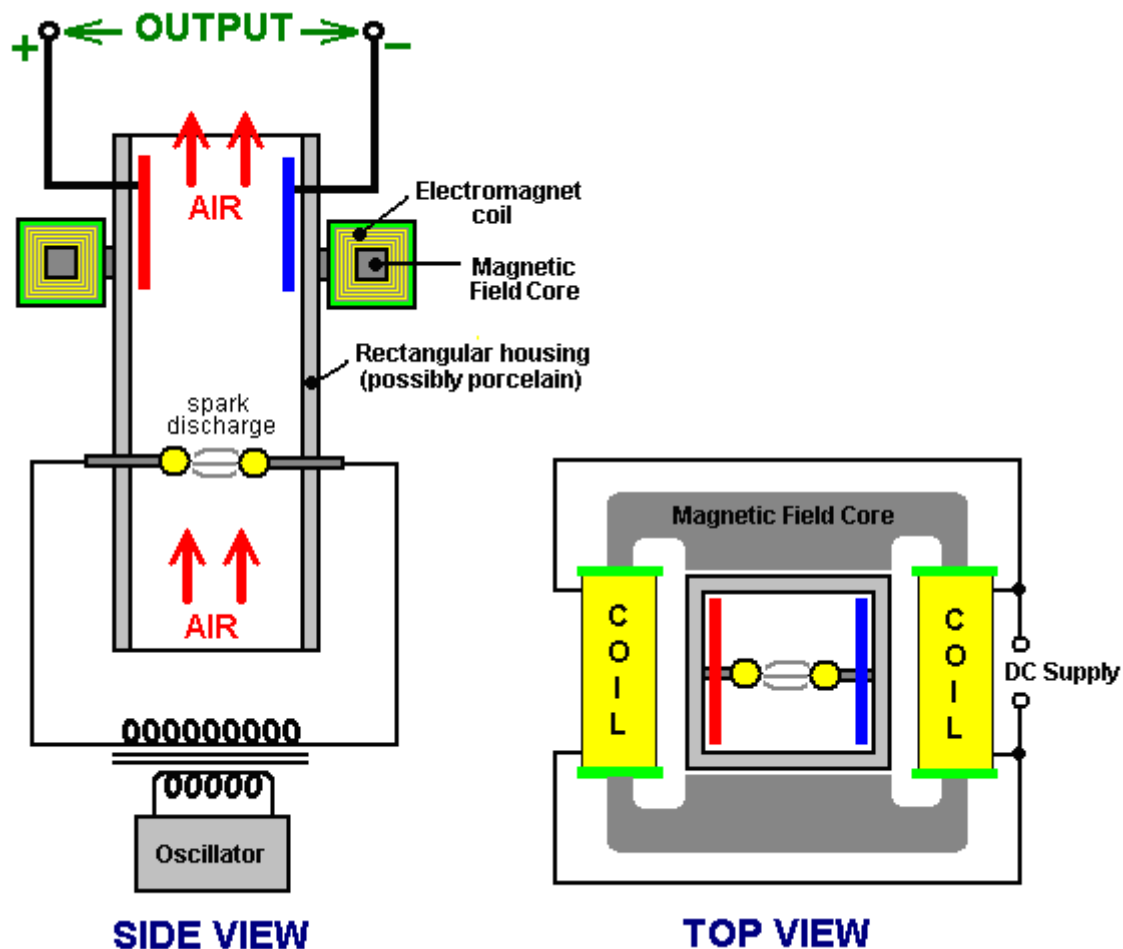

It is essentially, a rectangular cylinder which contains two spherical electrodes like a Wimshurst machine. The cylinder is positioned vertically, so that when the electrodes are powered up with high voltage to create spark discharges, the air inside the cylinder is heated which causes it to rise up the cylinder. The heated air is ionised, so a magnetic field generated by a surrounding electromagnet, causes the charged ions to move to opposite sides of the cylinder. Electrode plates positioned inside the cylinder, provide an electrical path for the excess positive and negative charges to flow together through the load - lighting, heating or motor circuits typically.

On the surface, this system would appear to be less than 100% efficient, in that the amount of power applied to the device to make it operate should be less than the amount of power drawn from it to drive useful loads. I am not sure that this is necessarily so. Firstly, the air already contains charged ions before this device starts to generate more. These naturally occurring ions gain in number when a thunderstorm is likely, even to the extent of giving many people a headache by their presence. These naturally occurring ions will be picked up by this device and without any input power needed to create them, they are capable of providing output power.

Also, the whole earth is immersed in the zero-point energy field. This is seething energy at the quantum level whose effects can be seen even at 'absolute zero'. This field is made of small random effects which

makes it hard to obtain useful energy directly from it. The field needs to be structured before energy can be drawn from it. One way to do this is to align the field with an event which causes coherent waves of energy to radiate outwards as a 'radiant energy' wave - something like the ripples caused on the surface of a pond of still water when a large stone is dropped vertically into the water. The ripple 'waves' move outwards from the 'event' until they reach the bank of the pond. If there was a generator attached to a float in the pond, it would be possible to pick up some energy from the ripples. The same can be done with 'radiant energy' waves if you can create them and know how to pick up energy from them.

Radiant energy waves can be formed by very short sharp uni-directional electrical pulses. Pulses less than one hundredth of a second are suitable for this. One way of creating pulses of that type is using a spark gap. In Tesla's device shown above, sparks are generated continuously. These sparks will generate radiant energy waves radiating out at right angles to the spark. Without a doubt, the vertical cylinder will have a mass of radiant energy shooting up it when it is being operated. This is in addition to the air ions which are being picked up. The only question is whether or not the electrode plate arrangement shown is capable of picking up any of this excess energy. Considering the metallic pickup device used by Edwin Gray to capture radiant energy as described below, it seems highly likely that some of that additional energy is, in fact, picked up and used to power the loads.

It should be noted that Tesla's device shown above, will generate UV radiation in the same way as any MIG or stick welder does, so care should be exercised to avoid looking at the arc or allowing the UV to shine on your skin, even if the skin is covered by clothing. You can get serious sunburn through thin clothing if it is subjected to strong UV radiation. Also, radio interference is likely to be generated by the arc, so screening should be provided during any tests. **WARNING:** Tesla accidentally discovered that electric spark discharges in air, ignite and burn atmospheric oxygen and nitrogen, producing 12,000,000 volt waves. The oxygen and nitrogen, both below atomic number 19 are thereby transmuted into alpha and beta charges (stripped helium nuclei with +2 charge each, and electrons with -1 charges each) by the powerful radiation produced, having a voltage potential of 12 Mev. This is almost three times the Mev level of gamma radiation emitted by radium, it may well be the reason why Tesla did not publicise the device shown above, and should you decide to experiment with it, please be aware of the potential hazard of this radiation.

A variation on the above device of Tesla's is given in the book "Physical Chemistry" by E. A. Moelwyn-Hughes, Pergamon Press, Oxford 1965, page 224. Rutherford and Geiger determined the fact that radium puts out alpha particles at the rate of 34,000,000,000 per second, each having two units of positive charge at 4.5 million electron-volts. This is a staggering amount of energy which ionises the air inside the housing and produces enough power to be capable of replacing the entire Four Corners power complex indefinitely.

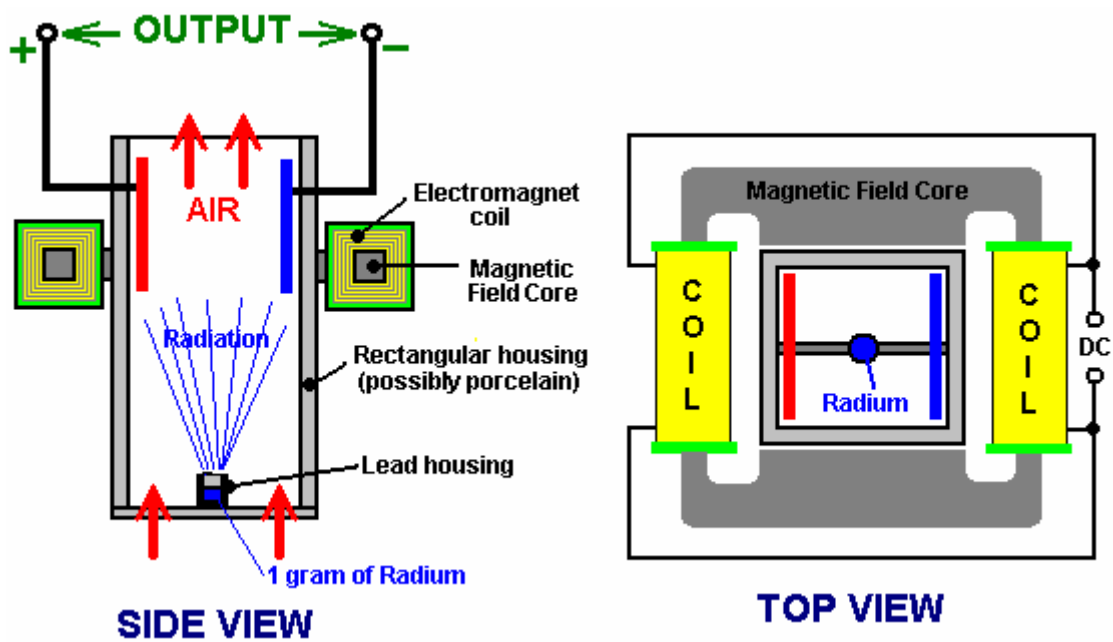

The variation of Tesla's device shown above, supports the lead container with its gram of radium on a strap across the bottom of the housing. The radiation ionises the air and the magnetic field separates the charges and directs them to opposite sides of the housing, to be collected and used via the electrode plates. There

does not appear to be any reason why strong permanent magnets should not be used instead of the DC electromagnet shown.

Dr Harold Aspden's Electrical Power Generator Patent.

Scientists freely acknowledge that more than 80% of the matter and energy in the universe is "dark matter" and "dark energy" where "dark" only means that we cannot readily see that form of matter and energy. The highly respected British scientist Dr Harold Aspden, has been awarded a patent for a system to collect this energy directly. The patent, which is one of several similar patents included in this eBook, is reproduced here:

Patent GB2390941

21st January 2004

Inventor: Dr. Harold Aspden

ELECTRICAL POWER GENERATING APPARATUS

Abstract

An electric generating device includes two capacitors **1** and **2**, each having a pair of concentric electrodes and in-series connection to inductors **3** and **4**. Each capacitor has an electrode connected to a high voltage DC source **5** and another connected to a low-voltage or earth terminal **6**. An AC Power output may be produced from terminals between each capacitor and inductor or from a transformer where the inductor is the primary winding. Electricity production may be sustained by drawing energy from the vacuum medium surrounding the electrodes.

Field of the Invention

This invention relates to a new and non-conventional means for the generation of electrical power. The energy source is the quantum underworld of space, the aether medium of the vacuum state, long recognised for its ability to allow the storage of electric field energy by reacting as its intrinsic charge is displaced, a process understood by physicists by reference to the research findings of Clerk Maxwell.

Background of the Invention

The current state of the art of electrical power generation does not recognise the possibility of ultimately tapping energy from the aether. Physics is taught on the basis that energy cannot be created or destroyed, inasmuch as it is conserved in all physical processes, though it can be degraded in its usefulness, as by burning of hydrocarbons and conversion into heat which dissipates as by radiation into outer space. The aether as a source or as an absorber of energy is not deemed to serve any specific role in the physics of energy deployment, it having been dismissed from consideration by invoking the notion of 'field energy' without admitting the specific physical reality of something in space that accounts for the properties involved.

Theoretical physicists have, however come to suspect that space devoid of matter is nevertheless a seething sea of activity subject to sporadic energy fluctuations which can create electron-positron pairs that exist momentarily before decaying back into their quantum underworld. Yet those same physicists deny all possibility that this energy resource of space itself can be exploited to provide useful power on a scale large enough to rival the role played by atomic power plants and fossil fuel generating installations.

Curiously, they do subscribe to the belief that one day they may be able to generate power on a viable commercial scale from fusion reactors by processes replicating what they believe sustains the Sun's heat output as hydrogen is transmuted into different atomic forms. In contrast with this rather elusive objective, it having proved beyond reach even after half a century of effort, this invention is based on success in generating power by replicating, not the Sun's onward energy decay, but rather a process akin to that by which the Sun itself was created from energy drawn from the enveloping aether medium.

The invention to be described below has emerged from an in depth theoretical investigation into the properties of the aether and quite independently of any of the well known claims of published record which feature at the fringe of mainstream scientific literature. A recent and very well-presented account of what amounts to a century of relevant energy history is the book 'The Search for Free Energy' by Keith Tutt, published in 2001 by Simon Schuster (ISBN 0-684-86660-9). Here in this book is a comprehensive background of information concerning the energy devices of several researchers but the references to Nikola Tesla and T. Henry Moray are particularly pertinent to the subject of this invention and, though imposing a

limitation on what can be legitimately claimed by this patent application, they serve also as a basis for a very important lesson to those engaging in this field of invention.

The lesson is that it is not sufficient to build and demonstrate something that works, if you do not fully understand why what you have devised actually does work. This is especially the case here where one is claiming a source of energy hitherto unknown. The invention to be described below will, in its broadest sense, appear to be quite similar to what T. Henry Moray is said to have demonstrated in showing that substantial electrical power could seemingly be drawn from the aether using a simple wire antenna strung between two poles.

However, as will be seen, the antenna is not needed and the reason is that the energy source is not the radiant emission by some process involving radio wave propagation through the aether, but rather what can best be described as a phase-lock that couples the apparatus with the quantised motion of electric aether charge. There is a technique, to be described below, by which it is possible to exploit this phase-lock condition by setting up an energy oscillation involving an apparatus component and its enveloping aether, the result being that energy in an immediately useful electrical form is imported into the apparatus from that aether.

Brief Description of the Invention

According; to one aspect of the invention, an electric power delivery circuit comprises two capacitors, each having a pair of electrodes formed by a pair of metal cylinders having concentric axes, each capacitor having an associated inductor series-connected to it to form a capacitor-inductor unit, DC voltage excitation means connected to a parallel combination of the two capacitor-inductor units, whereby to apply between corresponding electrodes of the capacitors a DC bias voltage which primes them with electric charge, and power output terminals, one at each point of connection between a capacitor and its associated inductor, whereby to provide for an AC power output owing to oscillations of electric charge between the two capacitors at the resonant frequency of the capacitor-inductor units.

According to another aspect of the invention, an electric power-delivery circuit comprises two capacitors, each having a pair of electrodes formed by a pair of metal cylinders having concentric axes, each capacitor having an associated inductor series-connected to it to form a capacitor-inductor unit, DC voltage excitation means connected to a parallel combination of the two capacitor-inductor units, whereby to apply between corresponding electrodes of the capacitors, a DC bias voltage which primes them with electric charge, each inductor being the primary winding of an electrical transformer, the secondary winding of which serves to provide an AC power output owing to oscillations of electric charge between the two capacitors at the resonant frequency of the capacitor-inductor units.

According to a feature of the invention the capacitors have no intervening solid or liquid dielectric medium separating their concentric electrodes.

According to another feature of the invention, two inductors are coupled electromagnetically by having a common ferrite core and their primary windings are connected to their associated capacitors in the polarity configuration which assures that, in their mutually resonant state, electric charge is exchanged between the two capacitors.

According to yet another feature of the invention, the central axes of both cylindrical electrode capacitors are mutually parallel.

According to a further feature of the invention, an electrical power delivery system comprises a plurality of these electric power delivery circuits, where the central axes have different angular orientations as between the different circuits.

According to a still further feature of the invention, in such a power delivery system, the difference in angular orientation of the central axes is at least 60° .

Brief Description of the Drawings

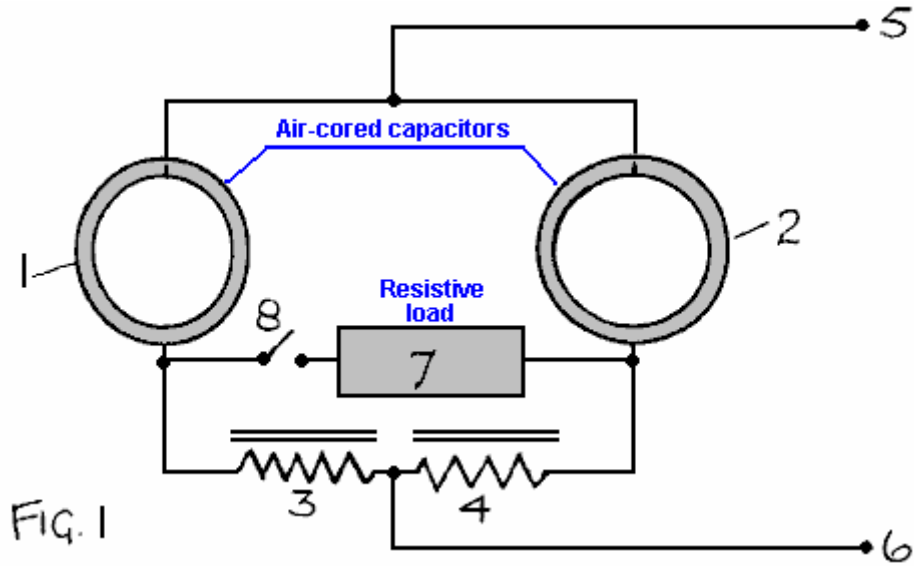

Fig.1 shows an electrical power generating circuit incorporating two concentric cylindrical capacitors having central axes which are parallel.

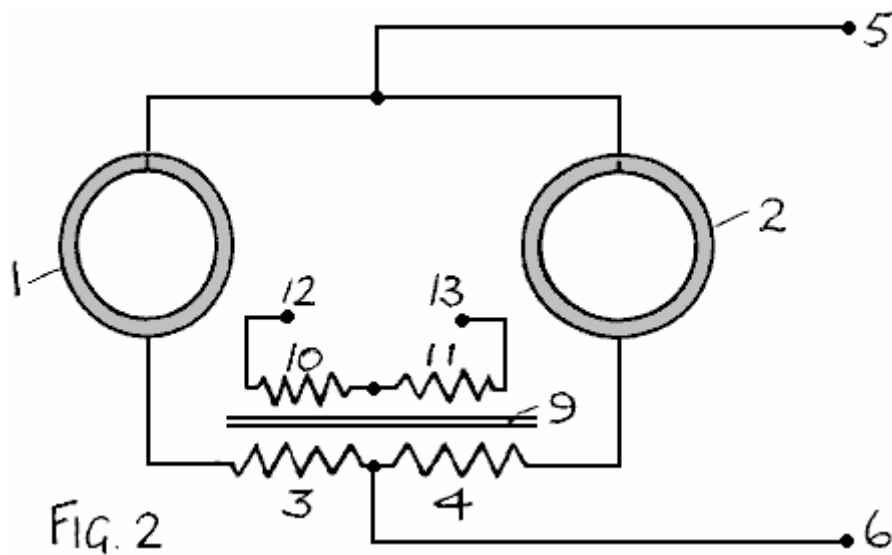

Fig.2 shows a modified version of the circuit of **Fig.1** with a transformer system providing the inductors and an output winding.

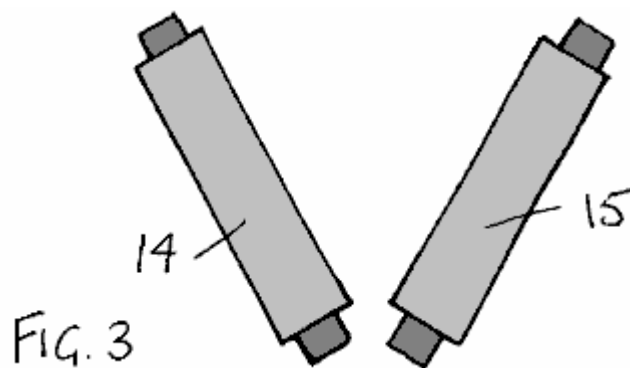

Fig.3 illustrates a mutually inclined capacitor system comprising two pairs of concentric cylindrical capacitors.

Detailed Description of the Invention

The invention draws energy from the aether. To understand why the invention works, one needs to understand the process by which the aether stores energy when an electric field is set up across the dielectric separating two capacitor plates. Moreover, one needs to understand the means by which the aether determines the quantum of action, specifically in the form of the Bohr magnetron and the unit of angular momentum linked to Planck's constant.

It is not sufficient to imagine that electric charge in the aether is displaced from a rest position in a background continuum of opposite charge polarity to which it is attracted by a restoring force. Indeed, one must consider such action to be superimposed on a system of charge which has an underlying jitter motion, a quantum theory theme associated with the German physicist Heisenberg (Zitter-bewegung, which has the dictionary meaning 'Circular fluctuation movement, of spin'). When these two factors are combined, and the constraint added of there being a phase-lock which keeps that jitter motion in synchronism as between the charges, one finds that the physical theory involved has some very interesting consequences.

One of these consequences is that a spherical or cylindrical volume of aether, if spinning bodily about a central axis, will acquire a magnetic moment and set up an electric field inside that sphere or cylinder that is directed radially with respect to the spin axis. A summary analysis is presented in the Appendix to this specification, being, in part a quotation from pages 31-33 of a booklet entitled 'The Theory of Gravitation' which the Applicant of this invention, Dr. Harold Aspden, authored in 1959 and duly published early in 1960.

The induction of electric charge by 'aether spin' was there shown to give a physical basis, both qualitative and quantitative, for the geomagnetic moment, the property of body Earth of setting up a magnetic field which created magnetic North and South poles at latitudes offset from the geographic poles, with the geomagnetic polar axis precessing slowly around the Earth's spin axis at a rate of several hundred years per revolution. By identifying its source as a rotation of a sphere of aether coextensive with body Earth, a volume of aether relative to which the Earth could have a component of motion even though the aether spin frequency is equal to that of the Earth, this axial tilt of some 17 degrees has a physical explanation. However, that aspect of the aether's role was not seen at the time as offering anything of promise technologically. The physics involved is nevertheless very relevant and directly pertinent to the experiments on which this invention is based, the findings of which would otherwise be quite baffling scientifically.

The applicant has, over the 40 or so years since the theory was first published, given a great deal of consideration to the theoretical implication that, just as aether spin can set up electric charge displacement inside coextensive matter, so the setting up of an electric field directed radially with respect to an s axis can induce aether spin about that axis and with it develop angular momentum. Indeed, in the author's onward publications on this subject, as, for example, 'Physics Unified' published in 1980 by Sabbeton Publications, P.O. Box 35, Southampton, England (ISBN 0 85056 0098), it is shown how the onset of the force of gravitation when a disordered aether consolidated into an orderly structured form caused protons to accrete more rapidly than electrons, owing to their higher mutual rate of gravitational acceleration. This created stars with all initial positive charge and the associated aether spin resulted in the stars acquiring their spin states and shedding matter which consolidated into planets which share the angular momentum so generated. The aether with its property of spin as related by its electric charge density according to the formula presented in the Appendix is therefore the key factor if we attempt to account for the creation of the stars which populate our universe.

That same formula, however, is equally valid if applied to the circumstance where a radial electric field is set up between the concentric cylindrical electrodes of a capacitor formed around a hollow dielectric cylinder. It tells us how fast the aether within that dielectric will spin. The related theoretical analysis shows that the quantum phase-lock feature of the aether imports from the external aether world an amount of energy equal to that supplied in setting up aether charge displacement, this imported energy being the dynamic energy corresponding; to the acquired aether angular momentum. Guided by the argument concerning stellar creation one can see that this aether angular momentum can be transferred to matter and this process also has its energy transfer implications.

However, one can wonder what happens if, after setting up a radial electric field in that capacitor having concentric electrodes, the applied voltage is reduced, thereby withdrawing electric field energy from the capacitor. The imported energy present in kinetic energy form as a cylindrical shell of aether spins about the central axis of the capacitor will tend to sustain electric charge displacement. To conserve energy, since the

aether phase-lock cannot force the expulsion of energy by obliging the enveloping aether universe to keep in step, this energy can only be shed by augmenting that released electrostatically. In other words, the net result is that an up and down fluctuation of the electric charge condition of the capacitor must give rise to an electric energy output that is, for the lowest dielectric constant (the permittivity of the vacuum), double the input in each cycle of change. One can then envisage an oscillation escalating in energy content powered almost wholly by aether input before one taps into that source of power to draw off energy at a rate consistent with stable operation.

This is, of course, a bewildering prediction that no physicist could imagine as being at all possible and yet, given the relevance of the theoretical argument involved, as applied to the phenomenon of geomagnetism and stellar creation, which are supported by strong evidence in that book 'Physics Unified', once such a notion is conceived it surely has to be put to the test by experiment. This then, after decades of effort before this realisation has dawned, is the basis on which the Applicant has only now come to appreciate the amazing technological possibilities that lie before us and is asserting by this patent specification that energy can in fact be tapped from the aether on a commercially viable scale.

Given that aether theory indicates that the special form of capacitor described above will, if subject to an oscillatory charge condition, generate an excess of energy, a question to consider is why such a phenomenon has not manifested itself in bench-type experiments performed in numerous electrical laboratories over the past one hundred years. Ostensibly the implication is that the capacitor will exhibit a negative resistance if used with an inductor as a component in what would become a self-resonating circuit. The answer to this may be that if such a phenomenon has occurred it has passed unnoticed or been regarded as spurious or noise-related, being something connected with radio interference etc. Alternatively, and as a function of the size and scale of the apparatus, the effect may have lacked an exciting trigger needed to overcome an energy threshold set by such factors as circuit contact resistance or contact potentials as well as the basic resistance of the inductors which, with the capacitors, form the resonant circuit.

Note that, even for a capacitor of quite large physical dimensions, having regard to its accommodation on top of a laboratory bench, the actual capacitance is necessarily quite small. being of the order of a billionth of a farad. This means that a capacitor charge fluctuation of the order of a volt would only imply energy fluctuations that are of the order of a billionth of a joule per cycle. The situation is quite different if perchance a DC bias voltage of, say, 5,000 volts is applied to the capacitor. Then a small superimposed voltage fluctuation makes the related energy fluctuations very much larger with much greater prospect of an escalating self-resonance being triggered.

With this in mind the applicant perceived a possible prior art link with the experimental claims reported by Dr. Moray who, in 1929 is said (see pages 46-50 of the above-referenced recently-published book by Keith Tutt) to have powered six 100 watt light bulbs plus a standard 575 watt electric flat iron, merely by providing an earth connection and coupling an input lead to an overhead wire antenna. The apparatus involved had no other source of input power but included a special arrangement of capacitors and presumably some kind of high frequency inductor/transformer unit.

In spite of the attention given to the Moray demonstrations, it seems that the secrets involved in the design and construction of the apparatus remain unknown and so cannot feature in the prior art of published record. Nor, indeed, can the anecdotal evidence of Moray's efforts serve to show that the subject invention has been put to prior use. The technology as to how to replicate the Moray device, always assuming it did perform as claimed, has therefore to be rediscovered and, indeed, given that there is reference to his detectors incorporating some special substance which was referred to as 'Swedish stone', possibly the dielectric he used in his capacitor construction, there is a considerable mystery to unravel. More to the point, however, one is led to believe that Moray was implying that the energy he was tapping was radiant energy drawn from the aether, with that antenna featuring prominently because, without it being connected, the energy output fell to zero. However, as he surely may well himself have known, one just cannot draw power on such a scale from a simple overhead wire strung between two poles and so, without know how, he would have suspected that the energy inflow was coming into his capacitors via the action of that mystery substance he called 'Swedish Stone'.

The applicant here suggests that, based on an insight into the quantum workings of the aether medium as outlined above, the curious discovery demonstrated decades ago by Dr. Moray may have been attributable to setting up an oscillation in a resonant circuit including, a concentric cylindrical electrode capacitor which had a voltage bias of the order of a thousand and more volts fed from a connection to that overhead antenna but drawing no significant current from that antenna other than enough to prime his capacitor with charge

and stimulate a high frequency fluctuation which could initiate an escalating circuit oscillation tapping aether energy from the aether spin induced in the capacitor dielectric.

This is speculation, but it is sufficient to justify the Applicant's interest in constructing a capacitor and seeking to verify the assumptions just made. Notwithstanding, the reference alcov to Dr. Moray and the note below concerning Nikola Tesla, what it leads to is new invention by virtue of full disclosure of details of operation and manufacture of something hitherto unknown, the actual means by which to harness a source of energy latent in the aether medium and deemed by those familiar with state of the art knowledge to be beyond man's reach. Furthermore, there are supplementary inventive features of a special nature because of the way the subject invention exchanges energy between two capacitors and also because the optimisation of aether power output from the capacitors is found to be a function of the orientation of the capacitor axes relative to the cosmic background owing to the Earth's rotation.

It seems here appropriate to mention something described by Nikola Tesla in his U.S. Patent No. 685,958. This was filed on 21 March 1901 and granted on 5 November 1901. It was entitled: 'Apparatus for the Utilisation of Radiant Energy'. By installing two metal plates, one high above the ground and the other at ground level, with wires connecting the plates to separate electrodes of a capacitor, it was stated that the capacitor became charged to a very high potential, the energy input being that radiated to Earth from outer space. This may well have motivated the efforts of T. Henry Moray but, so far as this Applicant's invention is concerned, no such input from overhead components is necessary as a quite different energy source is at work, namely the zero-point vacuum energy activity of our quantum underworld.

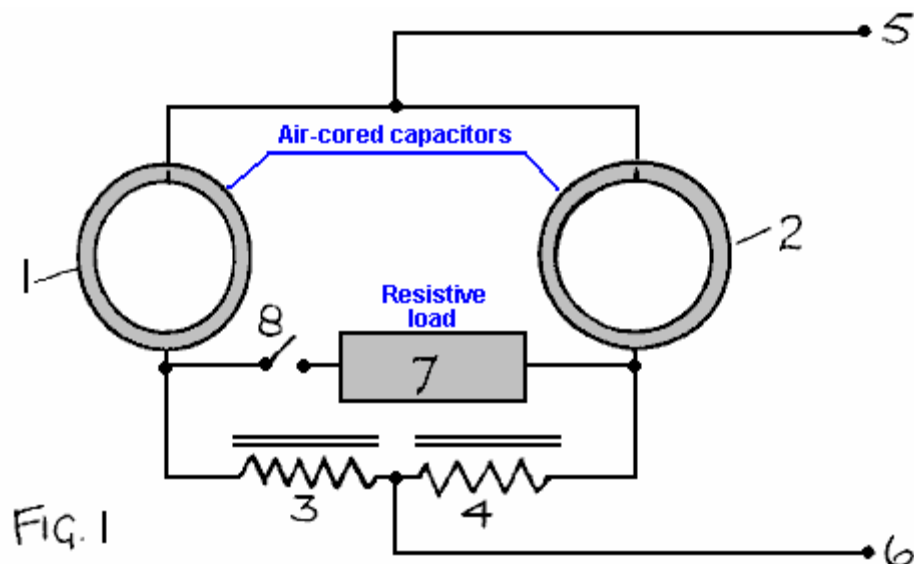

Referring now to **Fig.1**, two capacitors 1, 2 formed by concentric cylindrical metal electrodes and having their central axes parallel, form part of a resonant circuit combination by each being series-connected to an inductor 3, 4 having a ferrite core. Their inner electrodes are connected to a high-voltage DC source 5 and their outer electrodes are separately connected through their corresponding inductors to a low-voltage or earth terminal 6. A resistive load device 7 is connected via switch 8 between the junction points of the capacitors and inductors.

In operation, owing to spurious electrical signals induced in the inductors, or to an imposed electrical stimulus provided by means not shown, the priming electric charge of the two capacitors will develop oscillations as charge is exchanged between the two capacitors. There is energy inflow owing to the quantum coupling of electric charge displaced between the concentric electrodes of each capacitor and the quantum activity of the underworld of the enveloping aether. This affords an electrical energy output which is supplied upon closure of switch 8.

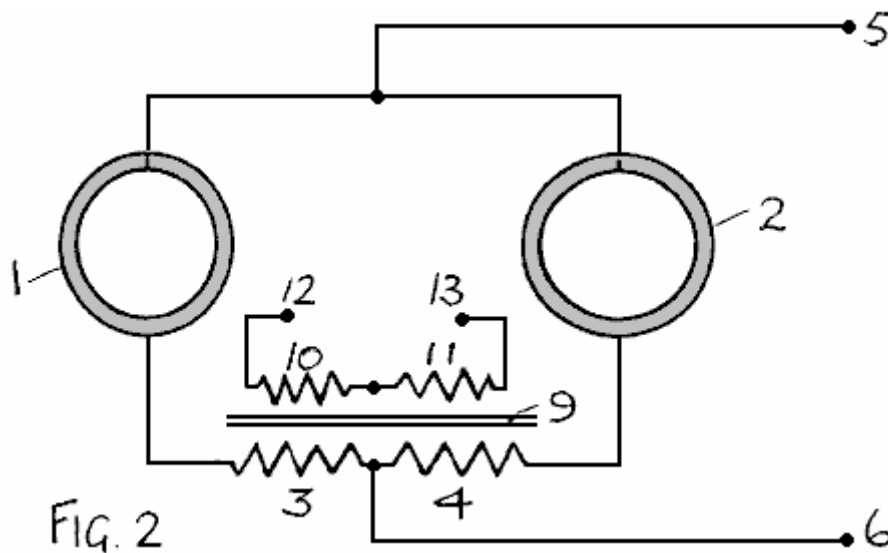

Referring to **Fig.2**, the inductors **3, 4** are shown to have a common ferrite core **9** and to have secondary windings **10,11**, which, by transformer action, can supply electrical power output between terminals **12** and **13**.

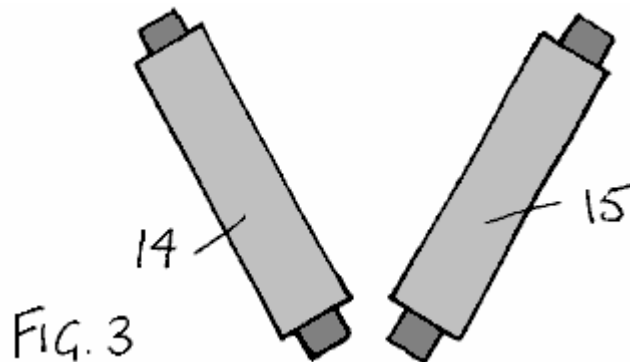

The apparatus of **Fig.1** and **Fig.2** will, when viewed in side elevation, appear as having a capacitor form with an outer cylindrical electrode within which there is a slightly elongated inner cylindrical electrode, to facilitate the high-voltage connection to that inner electrode. **Fig.3** shows, in very simple diagrammatic form, two such arrangements **14, 15**, with the central axes of the two pairs of capacitors mutually inclined. There may, however, be three or more such pairs of capacitors, each pair constituting a circuit such as is depicted in **Fig.1** or **Fig.2**.

The reason for configuring multiple capacitor systems, each with its own power output, in a combined manner with the outputs merged to supply an overall energy producing system is that the aether energy output of each capacitor unit is a function of axis orientation. This is because the quantum activity of the aether has its own preferred axis and, as the Earth rotates there is variation of the relative axial orientation in a daily cycle. Also, one needs to cater for systems applying, this invention in a mobile application, which also implies change of orientation and by having; the mutually inclined capacitor axis configurations one can be assured that the potential power output avoids the null situation that can occur if the capacitor axes of a stand-alone unit of **Fig.1** or **Fig.2** were to be at right angles to the aether quantum spin axis.

The capacitor electrodes can be of thin metal sheet foam and so of light weight and preferably are not spaced apart by any dielectric medium, whether liquid or solid. They need to be held apart by a simple insulating frame structure. The reason is, that the only dielectric medium that is operative in the functioning of the invention is the vacuum medium and to have a normal dielectric present implies more capacitance and so extra current oscillation without extra energy gain per cycle of oscillation. The key factor assuring operation is the need for circuit resistance to be low compared with capacitance that is solely attributable to the vacuum medium combined with the high voltage priming which greatly enhances the power output to weight factor.

The two capacitors of a pair are preferably of identical capacitance and structure, as are the inductors, so that the oscillation period of the two resonant sectors of the circuit is the same. The common ferrite core feature of the **Fig.2** configuration assists in this role.

The apparatus will normally be designed to operate at a capacitor frequency of the order of 100 KHz or more, and a voltage of 10,000 V or higher, and so the transformer output of **Fig.2** will be preferable with voltage duly adjusted to suit the application. The high frequency AC so produced can then be converted as needed by using the appropriate technology of known form.

Appendix

Extract from pp. 30-31 of 'The Theory of Gravitation', 1960 printed publication by the Applicant. Note that the earlier pages explained that the aether comprises a system of electric particles in a cubic crystal-like distribution set in a uniform background continuum of opposite charge polarity, the particle system and the continuum both sharing a common circular orbital motion of radius **r** and the relative velocity between the particles and continuum being the speed of light.

The Effect of Aether Rotation

Consider what happens when a large volume of the aether is rotating bodily. The continuum and particle system rotate together. There will be no resultant magnetic moment unless the particle distribution is disturbed. An evident disturbance is the centrifugal effect arising from aether rotation, but for the angular velocities of magnitude found in the solar system this effect is of negligible consequence. A much more important effect arises from the synchronising interaction between particles in the rotating volume. This requires that the particles shall move about their neutral points at the same angular velocity. Thus if a particle is to have a velocity component **V** directed in the plane of its orbit, whilst retaining a mean velocity **C/2**, its speed along its orbit must be of the form $C/2 + V \cos(P)$, where **P** is the angle subtended by a line joining the particle and the centre of its orbit relative to a fixed reference datum in the inertial frame. To satisfy the above requirement the centre of the orbit cannot be the neutral point. Evidently the particle is distant from this neutral point by $r + (2 V r / C) \cos(P)$. As **V** is much less than **C** the effect of this is that the particle is moving around a circular orbit whose centre has been displaced a distance $2 V r / C$ perpendicular to **V** in the plane of the orbit. If **V** is much less than $\omega x \cos(A)$, where **w** is the angular velocity at which the aether rotates, **x** is the distance of the aether particle from the axis of rotation, and **A** is the angle of tilt of the axis to the common axial direction of the aether particle system, this displacement distance is $2 (\omega x r / C) \cos(A)$. Consider a disc-like section of the rotating aether of radius **x** and unit thickness. Then, the effective charge displacement arising from the effective physical displacement of the particles is $2 \pi x s (2 \omega x r / C) \cos(A)$. The disc has acquired a uniform charge density of $4(\omega r s / C) \cos(A)$ esu/cc. The polarity of this charge depends upon the direction of rotation of the aether.

When evaluated from the aether data already presented, the charge density is found to be: $4.781 \omega \cos(A)$ esu/cc. This charge density represents a charge component which rotates with the aether.

Calculation of the Geomagnetic Moment

For Earth, **w** is 7.26×10^{-5} rad/sec and **A** is 23.5° . Thus the Earth's charge density is, from the above expression, 0.000319 esu/cc. The rotation of this charge gives rise to a magnetic moment of:

$$(0.000319)(4 \pi / 15)\omega R^5 / C \quad \text{where } R \text{ is here the radius of the Earth's aether.}$$

If **R** is greater than the Earth's radius (6.378×10^8 cm) by a small factor **k**, the Earth's theoretical magnetic moment becomes $(1 + 5k)6.8 \times 10^{25}$ emu. This may be compared with the measured value of the Earth's magnetic moment of 8.06×10^{25} emu.

An upper limit of 0.035 is imposed on **k** suggesting the Earth's aether terminates at a mean height of about 140 miles above the Earth's surface. This suggests that the ionosphere may be a phenomenon arising at the aether boundary.

Claims

1 An electric power delivery circuit comprising two capacitors each having a pair of electrodes formed by a pair of metal cylinders having concentric axes, each capacitor having an associated inductor series-connected to it to form a capacitor-inductor unit, DC voltage excitation means connected to a parallel

combination of the two capacitor-inductor units, whereby to apply between corresponding electrodes of the capacitors, a DC bias voltage which primes them with electric charge, and power output terminals, one at each point of connection between a capacitor and its associated inductor, whereby to provide for an AC power output owing to oscillations of electric charge between the two capacitors at the resonant frequency of the capacitor-inductor units.

- 2 An electric power delivery circuit comprising two capacitors, each having a pair of electrodes formed by a pair of metal cylinders having concentric axes, each capacitor having an associated inductor series-connected to it to form a capacitor-inductor unit, DC voltage excitation means connected to a parallel combination of the two capacitor-inductor units, whereby to apply between corresponding electrodes of the capacitors a DC bias voltage which primes them with electric charge, each inductor being the primary winding of an electrical transformer, the secondary winding of which, serves to provide an AC power output owing to oscillations of electric charge between the two capacitors at the resonant frequency of the capacitor-inductor units.
- 3 An electric power delivery circuit according to Claim 1 or 2, wherein the capacitors have no intervening solid dielectric medium separating their concentric electrodes.
- 4 An electric power delivery circuit according; to Claim 1 or 2, wherein the capacitors have no intervening liquid dielectric medium separating their concentric electrodes.
- 5 An electric power delivery circuit according to Claim 1 or 2, wherein the two inductors are coupled electromagnetically by having a common ferrite core and their primary windings are connected to their associated capacitors in the polarity configuration which assures that, in their mutually resonant state, electric charge is exchanged between the two capacitors.
- 6 An electric power delivery circuit according to Claim 1 or 2, wherein the central axes of both cylindrical electrode capacitors are mutually parallel.
- 7 An electric power delivery system comprising a plurality of electric power delivery circuits according to Claim 6, wherein the central axes have different angular orientations as between the different circuits.
- 8 An electric power delivery system according to Claim 7, wherein the difference in angular orientation of the central axes is at least 60° .

Comments by Dr Aspden on 19th March 2006:

OUR ENERGY FUTURE

A Message of Vital Importance

The world needs a new source of energy, one that is not an exhaustible commodity subject to power-play as between nations. Yes, one can dream and then awake to say this is impossible, but I urge those with the necessary skills to heed what I have to say in my three messages below.

First, however, let me introduce myself. My name is Dr. Harold Aspden. I am retired and elderly but have had a lifelong scientific interest in fundamental physics relevant to the energy theme. My 6-year university education in U.K. was at Manchester University and Cambridge University (Trinity College). My 33-year working career in U.K. comprised 9 years with English Electric and 24 years with IBM. Though having high technical qualifications (see below), being interested in the specialised field of protecting inventions pertaining to electrical engineering, I became a Chartered Patent Agent and later a European Patent Attorney. My last 19 years with IBM were spent as Director of IBM's European Patent Operations. This was followed, in my early retirement, by 9 years as a Visiting Senior Research Fellow at Southampton University and thereafter my scientific interest has been a private pursuit evidenced by my writings as on this and my related websites. My formal qualifications are: B.Sc., Ph.D., C.Eng., F.I.E.E., F.I.Mech.E., C.Phys., M. Inst.P., C. Sci., Wh.Sc.

Message No. 1: Physicists have come to recognise that there exists a quantum underworld alive with energy and permeating all space. However, their related research aims merely at probing experimentally the spectrum of elementary particles that have a transient existence as a product of that energy activity. The reward they seek is recognition should new particles be discovered and, by their properties, reveal

connections with other particles that help in formulating a new theory or verifying an existing theory. Sadly, they do not see that quantum underworld as a potential source of energy that we can harness. Nor have they understood how most of the energy shed in creating matter formed the elementary particle which bears the name proton and which, together with the electron, constitutes the hydrogen atom.

There is also a secret they have yet to fathom. It is the effect of creating a radial electric field centred on electrical charge around which that quantum underworld can develop a state of spin that causes it to shed energy. In the presence of a radial electric field set up by an electrically charged body, whatever constitutes that quantum underworld that permeates all space shares a motion like that of sequence dancers who keep in step with one another as they move around the dance floor, a synchronous motion, which, in the presence of that radial electric field can only be held if a secondary motion develops around an axis centred in that radial field.

How else could the Sun spinning about its own axis have come into existence? Here we have gravity attracting hydrogen atoms and pulling them so closely together that ionisation occurs, meaning freeing some electrons from their proton bonding, and so, because the mass of a proton is very much greater than that of the electron, creating a Sun having a body that is positively charged sitting within an outer shell of negative electron charge. Two free protons experience a mutual rate of gravitational acceleration that is 1836 times that experienced by the interaction of two electrons. The body of the Sun, therefore, has a uniform mass density and a uniform positive charge density enclosed within a compensating negative charge at its surface. This is because gravitational compaction forces balance the expansion forces attributable to electrostatic repulsion. It further means the presence of a radial electric field within the body of the Sun and, in turn, owing to the effect of this field on the space medium of the quantum underworld, this induces a state of spin accompanied by release of energy from that medium to feed the kinetic energy of that spin.

In depth analysis of the physics involved, meaning the effect of the resulting radial electric field on that quantum underworld, then allows one to calculate the resulting rate of spin and thereby understand how the solar system was created.

So, if the reader is a physicist, here is the way forward and full guidance on this is to be found on my parallel website www.aspdn.org or in a new book of mine entitled Creation - The Physical Truth, that will be published in the near future. However, if the reader is not a physicist but has the technological aptitudes of the university-trained electrical engineer then it is Message No. 2 below that warrants attention.

Message No. 2: If it were possible to generate electrical energy by tapping an omnipresent medium it is surely to be expected that the occasional natural phenomenon might already have hinted at this possibility. Consider, therefore, the thunderball, a glowing spherical object sometimes seen, especially following a lightning storm. It appears ethereal in the sense that it can move unimpeded through matter, yet remains an enigma, an unsolved mystery of record in the annals of science. Lightning strokes are high current discharges which, as electrical engineers well know, can develop a 'pinch effect' squeezing the electron-carried current into a filamentary flow within a cylindrical channel of positively charged air. That implies a radial electric field, a pulsating radial electrical field if the discharge surges, a sure recipe for something to happen that could form a miniature Sun, the thunderball. So when we look at a thunderball we are looking at a natural phenomenon that has drawn energy from that quantum underworld of space, energy which is then dissipated, but energy shed by a process we can surely harness, once we understand the physics involved.

Scientists lacking the necessary imagination do not seek to understand how the thunderball is created and so they seldom write about it. So here we have something to think about. It is Nature's message telling us: "Produce a radial electric field, one that pulsates, and you can develop a spin that taps energy from the quantum underworld of space." As engineers, however, we need to be practical and, if possible, we should avoid trying to replicate a phenomenon that involves powerful electric discharges, if there are better ways in which to proceed.

So now I come to my primary theme in this Message No. 2. It is a brief survey of a few of the claims of record that have declared a mysterious energy gain and have features which I see as relevant to what has been said above. In particular I draw attention to the research findings of four different pioneers in what has come to be termed 'The Search for Free Energy', this being the title of a really excellent book by Keith Tutt, published by Simon & Schuster in 2001. Three of these are described in considerable detail in that work. I now ask you to keep in mind my reference to a radial electric field as I mention each of them below and do realise that electrical structures of cylindrical form are a key feature.

Nikola Tesla is famous for his research concerning electromagnetic induction and high voltage solenoidal transformer apparatus (Tesla coils) and he is said to have demonstrated an automobile which derived its

power by tapping energy from space. He did not disclose its design details and died leaving us with a mystery. Tesla coils comprise large solenoidal windings concentrically mounted and operate with high voltage pulsations between their cylindrical forms which must produce a pulsating radial electric field between those windings. So, although electromagnetic induction effects are the primary focus of attention, there is here scope for the electrical action described in Message No. 1 above. Tesla may well have stumbled experimentally upon a way of tapping energy from space, but without understanding the true underlying physical process.

Dr. Henry Moray, a pioneer of the 1920-1930 era, demonstrated something which merely needed a kind of antenna, a wire connected from tree tops to earth via electrical apparatus in the boot (trunk) of his automobile. It is said that the latter included several capacitors and that a kilowatt level of power was generated. In this case the automobile merely carried the test apparatus for demonstration at a location remote from a built-up area and any electrical power line interference. No doubt Moray was seeking to follow in Tesla's footsteps by drawing energy from the Earth's electric field, known to be measured in hundreds of volts per metre. It is likely that those capacitors were of Leyden jar type configuration, that is cylindrical in structural form, and that the wire linked to tree tops tapped charge at a kilovolt voltage level. However, the output power claimed could surely not have come from that source. Therefore one must assume that Moray used that treetop voltage input merely to prime the voltage across his capacitor electrodes, whilst incorporating some special feature in the operation of his electrical circuit that gave access to the energy of the quantum underworld. Capacitors having concentric electrodes of cylindrical form will, when charged electrically, have a radial electric field in the space between the electrodes. Several capacitors coupled together could give rise to oscillations of charge as between the capacitors and so lead to a pulsating radial electric field. Yet though demonstrating as possible something that should not be possible, a mysterious inflow of energy able to illuminate several light bulbs, Moray could surely not have understood the true physical process that was feeding energy into his apparatus. Again I see this as relevant to what is stated in Message No. 1.

Stan Meyer demonstrated apparatus that included sets of concentric tubular electrodes enclosed in a cylindrical container filled with water, the electrodes being fed by high voltage (5 KV) pulses. Combustible gas was generated, a mixture of hydrogen and oxygen, the burning of which generated far more heat than could be accounted for by the electrical energy input. Energy was being tapped as if from nowhere unless the source was the ambient medium of space itself. Here there was a pulsating radial electric field and electric charge oscillating between different components in Meyer's apparatus. Meyer did not offer any useful explanation as to the physical process underlying what he could demonstrate but persisted in conveying the message that the invention was wonderful and talking about a multiplicity of applications such as powering automobiles, ships etc. This is the project not mentioned in Keith Tutt's book. As for the Tesla and Moray projects Meyer's research was a U.S. based activity. It did, however, attract the interest of a British Admiral, Admiral Tony Griffin who was concerned with the impact of new technology upon the marine industries. Griffin witnessed Meyer's demonstrations and was interested in its development. Indeed an article on the subject mentioning Admiral Griffin and entitled 'Free Energy for Ever' was published in the January 1991 issue of the U.K. magazine *Wireless World*. The importance of the article was evident from the fact that the Editor of that magazine was the author.

Paul Baumann, a member of a Christian community in a isolated valley high in the Swiss Alps has constructed working free energy devices which have been demonstrated to visitors. The first working prototype was relatively small and included a pair of glass Leyden jars, concentric capacitors. Keith Tutt in his book devotes 30 pages to this subject. The high voltage needed to prime the capacitor operation was generated by a Wimshurst machine driven by the electric power generated. The community has, however, kept design details secret. In spite of such information as is available the underlying physical process governing its operation remains a mystery. Yet I can but feel confident that what I say in my Message No. 1 provides the answer.

Message No. 3: My Message No. 1 has drawn attention to the physical process by which the vast amount of energy needed to create the Sun was extracted from the quantum underworld that permeates all space. My Message No. 2 has drawn attention to the reported efforts of just some of the several energy research pioneers who actually demonstrated apparatus that, contrary to accepted scientific principles, drew energy from a mystery source. My Message No. 3, based on recognising the common physical feature can but be the suggestion that technology for generating our power needs from the hidden underworld of space has to be possible. Accordingly, I will now outline what I see as the basis on which to build the ultimate power generating device that harnesses the physical principles presented in Message No. 1.

Being 78 years of age and no longer having access to university research laboratory facilities, I can but leave it to others to take note and, hopefully, prove me right. If proved right then the world will benefit and the

impending energy crisis will be avoided. Hopefully also, the scientific community might then be willing to accept my claim as to how the quantum underworld deploys its energy into proton creation and is active in producing the phenomenon of gravitation. I know of no other theory that has been able to derive theoretically the value 1836.152 of the proton/electron mass ratio. I would like to see that recognised as my contribution to man's knowledge.

Consider a capacitor formed by a pair of concentric cylindrical electrodes, something many of us remember from the school physics laboratory, the Leyden jar. However, the capacitor structure I have in mind is very much larger and has to be operated at a quite high voltage. When that voltage is applied between the electrodes electric charge is displaced in the underlying vacuum medium located between those electrodes. A commensurate amount of electric charge is thereby held in place on those electrodes, a negative polarity charge on one and a positive polarity charge on the other. Given my claim that this is accompanied by 'vacuum spin', aether rotation, which has imported an equal amount of energy owing to a quantum phase-lock as between the charge of the vacuum medium, we have the energy gain we seek to exploit.

The problem, however, is that, with this simple capacitor configuration, the only control parameter available is the reduction of the voltage between the electrodes. This will shed energy within the circuit of the apparatus used, the outflow of electric charge at the voltage difference merely delivering energy equal to that originally supplied by our voltage source. The added energy imported from space is merely dispersed by the 'vacuum spin' slowing down but expanding beyond the bounds of the capacitor electrodes as it conserves its angular momentum. The energy imported from the quantum underworld of space has no way of enhancing the energy output of the capacitor circuit and so is left to dissipate itself and eventually be reabsorbed by that quantum underworld that pervades all space.

However, now consider a concentric electrode capacitor having a third cylindrical electrode intermediate the inner and outer electrodes. Here we have a control parameter other than the voltage between the outermost and innermost electrodes, because we can wonder about the voltage of the central electrode whilst retaining the other voltage difference at a constant high level. In fact, by keeping the latter voltage difference constant but varying the voltage of the intermediate electrode we can decrease the capacitor energy of one half of the overall capacitor as that of the other half decreases. The imported energy shed by one half of the overall capacitor can then contribute to the action that energises the other half and thereby induce oscillations from which energy can be extracted and deployed as a power source.

One needs two such capacitors having their central electrodes coupled through a load circuit in order to capture the 'free energy' inflow and get it to do useful work rather than being dissipated. An inductance in the coupling circuit can determine the oscillation frequency and, since the energy inflow increases with frequency, this should no doubt be well into the kilocycle region. The figure below is a simple schematic diagram of the electrical apparatus that I have in mind.

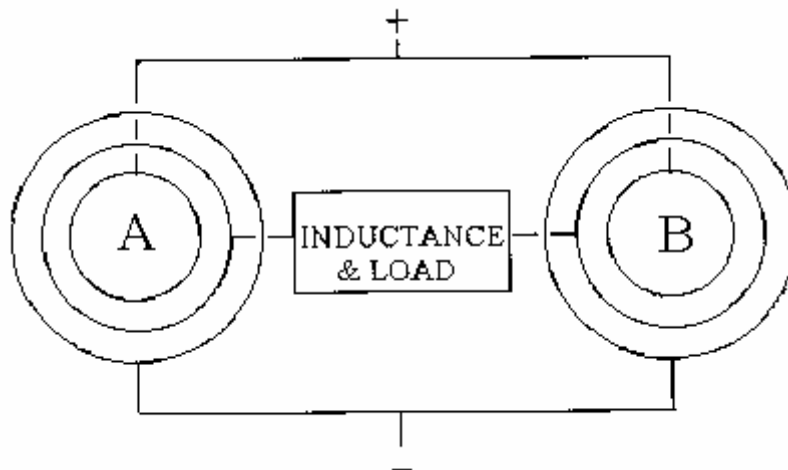

So my Message No. 3 is what I may describe as a 'thought experiment', one that I cannot verify myself, owing to my age and lack of facilities. I therefore can but record my thoughts and hope that others will prove me right and not wrong.

The capacitors depicted in the figure should have their electrodes spaced so that the capacitance C as between their central and outermost electrodes is the same as the capacitance C between their central and innermost electrodes. Suppose that the outermost electrodes are maintained at a voltage of 20,000V relative

to the innermost electrodes. This means that the two central electrodes will be at an intermediate voltage which we expect to be 10,000V in the absence of oscillations. However, as with any ever-active electrical system, there will be minor voltage fluctuations affecting the central electrodes. So we may ask what happens if the voltage of the central electrode of capacitor A decreases owing to electric charge being shed by the inner capacitance C but gained by the outer capacitance C. Think about that for a moment. You will see that it implies reciprocal action in the opposite sense by capacitor B, as current flows from A to B via the central inductor coupling. Yet no net current flows from the 20,000V power source.

Now, of course, common sense backed by our scientific training assures us that this system can but keep its equilibrium without those minor voltage fluctuations building up in some way. Yet, if we heed Message No. 1 and keep in mind Message No. 2, there is a question we must ask. If current does flow through that central link between A and B, one half of A and one half of B both shed energy and so release the imported 'vacuum spin' energy, if such is present. This occurs as other halves of A and B have to gain energy and as angular momentum of the imported 'spin energy' spreads into the other sections of the capacitors. The question then is: "Does that imported energy escape, as it does for the two-electrode capacitor configuration, or might it be retained and so augment the action?"

I submit the answer can only be provided by actual experiment. If the energy does escape then there is nothing further to discuss. However, if some of that energy is captured then we can expect an escalation of oscillations in that inductive link and so can then say that a new source of energy has been discovered. Those oscillations will be a function of the capacitance C and the inductance of the load circuit. Given a high frequency and a high voltage a significant level of power per unit volume of capacitor structure will be produced. If power output at a level commensurate with the claims of Tesla, Moray, Meyer and Baumann results the world's energy future is then assured. A pollution-free energy resource powered by the quantum underworld of space will be at hand wherever we are on body Earth.

The Design of Paulo and Alexandra Correa.

Paulo & Alexandra Correa have discovered a way of converting Tesla's longitudinal waves into ordinary electrical power. They have made US Patent Application 2006/0,082,334 entitled "Energy Conversion Systems" in which they show various ways of achieving this energy-type conversion.

Their techniques range from applying the longitudinal wave energy coming from a Tesla Coil directly to two capacitors via diode rectification and the voltages generated are related directly to actual ground earth potential:

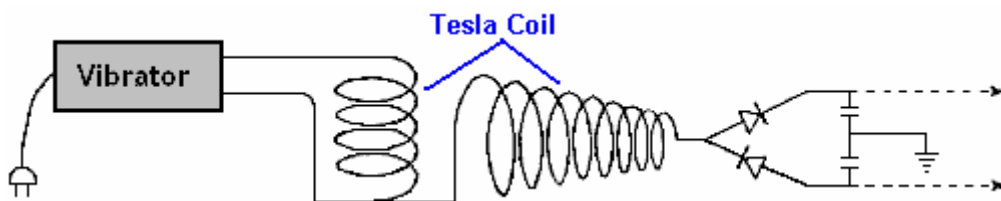

The patent application forms part of this set of documents so the full details can be examined. A theory of operation is presented based on their many experiments and observations, and the practical form of one of their conversion devices is:

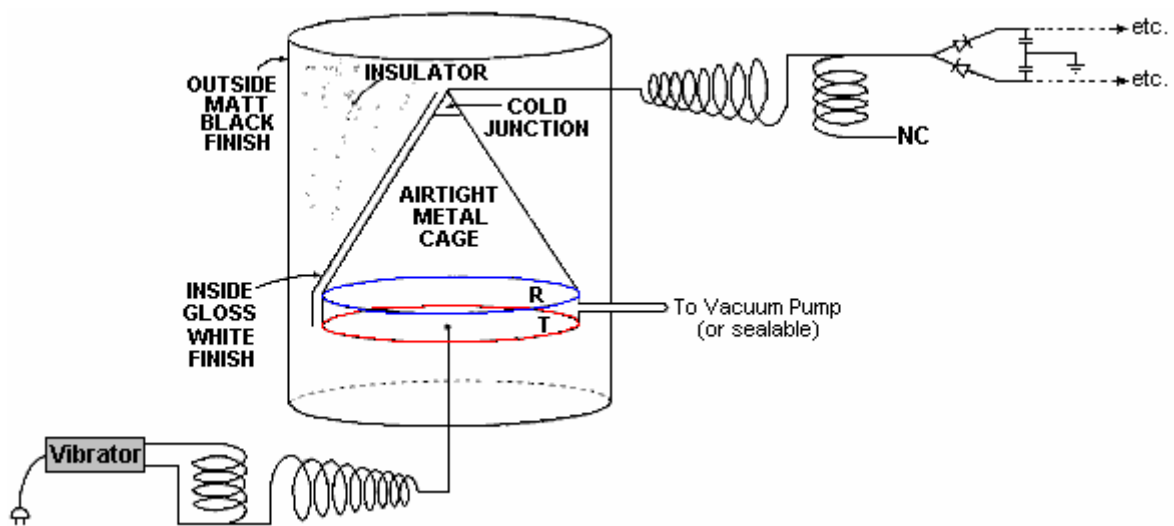

Where the active pick-up plates **R** and **T** are encased in a cylinder and are provided with a cone shape to assist the procedure. The patent application contains a good deal of information and is worth reading.

Professor Konstantin Meyl.

Another key person in the advancement of current theory and analysis is Professor Konstantin Meyl who has described how field vortices form scalar waves. He has described how electromagnetic waves (transverse waves) and scalar waves (longitudinal waves) both should be represented in wave equations. For comparison, transverse EM waves are best used for broadcast transmissions like television, while longitudinal scalar waves are better for one-to-one communication systems like cell phones.



Konstantin Meyl

He also presented the theory that neutrinos are scalar waves moving faster than the speed of light. When moving at the speed of light, they are photons. When a neutrino is slowed to below the speed of light, it becomes an electron. Neutrinos can oscillate between e^- and e^+ . Fusion involves e^- , and a lightning flash involves e^+ . Energy in a vortex acts as a frequency converter. The measurable mixture of frequencies is called noise.

Dr. Meyl has pointed out that Tesla measured the resonance of the Earth at 12 Hz. The Schumann resonance of the Earth is 7.8 Hz. Meyl shows how one can calculate the scalar wave of the Earth to be 1.54 times the speed of light. He has developed a model which ties the expansion of the earth to be the result of the earth's absorption of neutrino energy. The ramifications of this model are that neutrino energy can be tapped. He took this to the next step and postulated that Zero Point Energy is neutrino power – energy from the field; available at any time, and present everywhere. To show the place of neutrinos in conventional science, Meyl noted that the 2002 Nobel Physics prize was in regards to work on neutrinos. The English-language version of Dr. Meyl's web site is at <http://www.meyl.eu>.

Nikola Tesla's Magnetohydrodynamic Propulsion Drive.

Tesla performed an experiment in which he applied high-voltage high-frequency alternating current to a pair of parallel metal plates. He found that the 'space' between the plates became what he described as "solid-

state" exhibiting the attributes of mass, inertia and momentum. That is, the area transformed into a state against which a mechanical push could be exerted. This implied that, using this technique, it should be possible to produce a spaceship drive anywhere in space, if the mechanism for thrusting against the 'solid-state' space could be determined. Further experiments convinced Tesla that powerful electromagnetic waves could be used to push against (and pull against) what appears to be 'empty space'. The drive principle is based on the Hall-effect used in semiconductor magnetic sensors, and is called the magnetohydrodynamic ("MHD") effect. This might be illustrated like this:

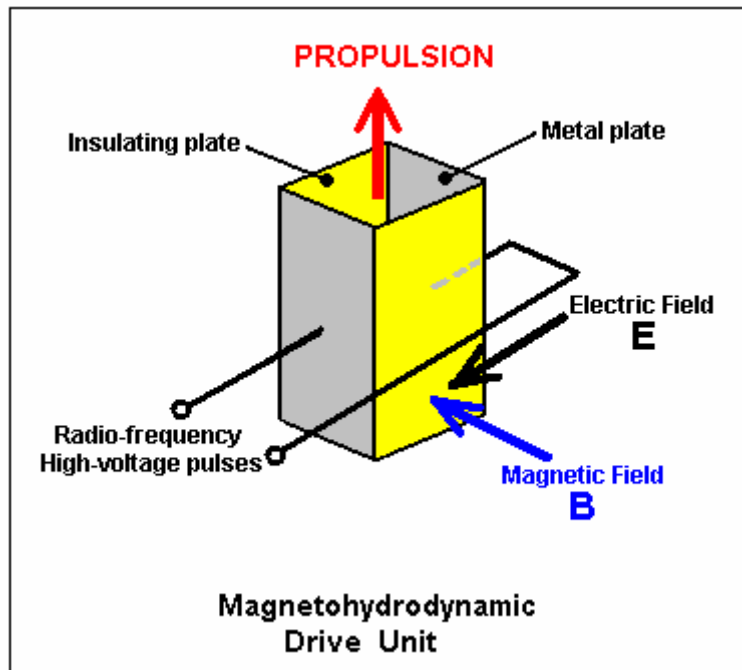

Here, a box is constructed with two metal plates forming opposite sides and two insulating plates holding them in position and surrounding an area of 'space'. High-frequency, high-voltage alternating current is applied to the metal plates and this creates an electric field "E" acting between the plates as shown in black. A magnetic field "B" is generated by the electrical field. The magnetic field acts at right-angles to the electric field, as shown in blue. These two fields produce a propulsion thrust "F" shown in red in the diagram. This propulsion force is not produced by ejecting any matter out of the box, instead, it is produced by a reaction against the 'solid-state' condition of space-time caused by the high-frequency electromagnetic pulsing of that area of space. This is enormously more effective than a jet engine. The thrust increases with the fourth power of the frequency, so if you double the frequency, the effect is sixteen times greater.

To put this into perspective, consider the force being applied against gravity to lift an object into the air. The force pulling the object downwards is gravity and its strength is given by:

Gravitational force:

$$F = g \times M \times m / r^2$$

where

g is the gravitational constant ($6.672 \times 10^{-8} \text{ cm}^3 \text{ g}^{-1} \text{ s}^{-2}$)

M is the mass of the first body

m is the mass of the second body and

r is distance between the two centres of mass

The lifting force is given by:

Lorentz Force: Force on an object = Electric force + Magnetic force

$$\mathbf{F} = q \times \mathbf{E} + q \times \mathbf{v} \times \mathbf{B}$$

where

q is the charge on the object,

\mathbf{B} is the magnetic field,

\mathbf{v} is the velocity of the object and

\mathbf{E} is the electric field

How do these forces compare? Well, the electromagnetic force is stronger than the gravitational force by a factor of about 2,200,000,000,000,000,000,000,000,000,000,000 times. That number (2.2×10^{39}) is too big for anybody to really visualise, so let me put it another way.

If the amount of energy used to mechanically lift an object a distance of one hundredth of an inch (one quarter of a millimetre) off the ground, were used as an electromagnetic lifting force, then that amount of energy would lift the object more than 3,472,222,000,000,000,000,000 miles off the ground, or in metric units, more than 5,588,001,700,000,000,000,000 kilometres off the ground. This kind of drive is an entirely different kind of animal. This Hall-effect type of drive if used in a spaceship would require only a very small amount of input power to drive the ship at great speeds and over great distances.

As the device shown above operates directly on the space-time field which penetrates all matter, there would appear to be no reason why it should not be used to drive a conventional vehicle by positioning it in a horizontal position rather than the vertical position shown in the diagram. Throttle operation could be by very slight adjustment to the frequency of the AC pulses applied to the metal plates. However, Bill Lyne indicates that horizontal movement is better achieved by producing Tesla's very short, high-voltage high-frequency DC pulses at the front of the vehicle while at the same time generating very high-voltage high-frequency AC waves at the back of the vehicle. This style of drive is said to pull the vehicle along rather than push it along.

The **Unified Field Theory** is being searched for by scientists who want to come up with a theory which encompasses the force of gravity with the electromagnetic force. In my opinion, they would have more chance of success in trying to find a needle in a haystack which does not contain a needle since when the entire haystack has been disassembled, it becomes clear that there never was a needle in it. In my opinion, there is no such thing as a "force of gravity", in fact, there is no such thing as gravity. Find that hard to believe? Well, let me explain.

If when standing, you hold an object a waist level and let it go, it "falls" and lands near your feet. Yes agreed, and yet I suggest that there is no such thing as gravity. If you suspend a pendulum close to a mountain, the pendulum does not hang down vertically but moves slightly towards the mountain. This is said to be because the mountain attracts the pendulum. Sorry Chief, but I suggest that it just ain't true and the mountain does **not** attract the pendulum. The Moon orbits around the Earth which requires a continuous acceleration inwards towards the Earth and this is said to be caused by the attraction of gravity pulling the two bodies of matter together. Well, yes the Moon does orbit the Earth but not because of "the force of gravity".

The reason why "the force of gravity" is so tiny compared to electromagnetism is because there is no such force at all. Yes, indeed, all of the observed phenomena which are supposed to be gravitational, do exist exactly as seen, but I suggest that there is no such thing as "the force of gravity" and the Unified Field Theory is not needed. Let me explain:

The Zero-Point Energy field exists everywhere in the universe and it flows in every direction equally. It acts like a flow of particles thousands of times more tiny than electrons, and so, it flows through matter. No matter can shield completely from the flow of this energy field. But, a tiny percentage of the flow does happen to collide with the electrons, atoms and molecules of matter as the energy flow moves through matter. The bigger the chunk of matter, the more of the energy flow collides with it. The collisions convert the energy into additional mass, which is why our Sun is not losing mass as rapidly as theory would predict. The situation is like this:

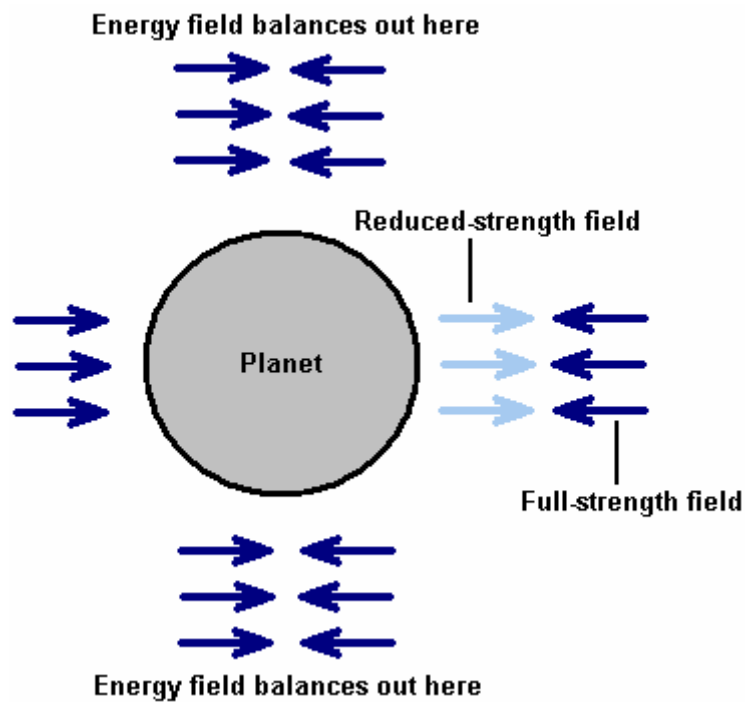

The force of the Zero-Point Energy field is slightly reduced having passed through (and interacted with) the large mass of the Earth. This reduced strength is indicated in the diagram by the light-blue arrows. The incoming Zero-Point Energy field is not reduced in strength in any significant way as the molecules in the atmosphere are not nearly as tightly packed as those in the matter which makes up the Earth itself. The imbalance of these two thrusts causes a net push towards the surface of the Earth.

For clarity, the diagram only shows the field acting in one direction, while in reality, the same situation applies in every possible direction around the planet. When you let an object go and it moves towards the surface of the planet, it is not being pulled down by “the force of gravity”, but instead, the downward push of the Zero-Point Energy field is greater than the upward push of the Zero-Point Energy field which has just passed through the planet. The object moves “downwards” because the push from above is greater than the push from below.

Exactly the same thing applies to cause the effect that a mountain appears to have on a pendulum. In reality, the mountain has no effect on the pendulum, apart perhaps from a minor electrostatic influence. The main effect is caused by the flow of the Zero-Point Energy field:

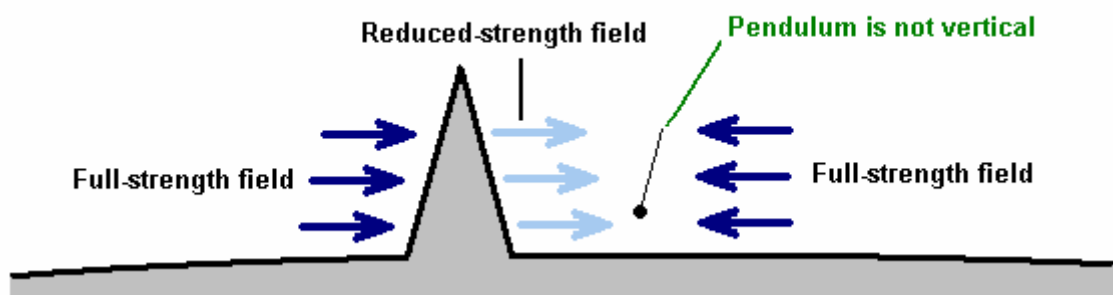

Here, the (very roughly drawn) mountain, reduces the push of the Zero-Point Energy field which passes through it, due to its interaction with the matter with which it collides on its trip through the mountain. The push of the Zero-Point Energy field on the side of the pendulum is not diminished, so there is a net push towards the mountain and that makes the pendulum move in the direction of the mountain. The effect is not very large, so the pendulum does not move much out of the vertical as the downward push towards the surface of the planet is quite marked, so the pendulum needs to be very near the mountain for this effect to be observed.

This can also be seen in the Casimir Effect where two non-magnetic metal plates, which are not carrying an electrostatic charge, are suspended very close to each other. The plates do not hang straight down but move towards each other. This is the same effect as is caused by a mountain near a stationary pendulum, or plumb-line. Each plate screens out a little of the Zero-Point Energy field which passes directly through both plates, so the second plate gets slightly less of a push:

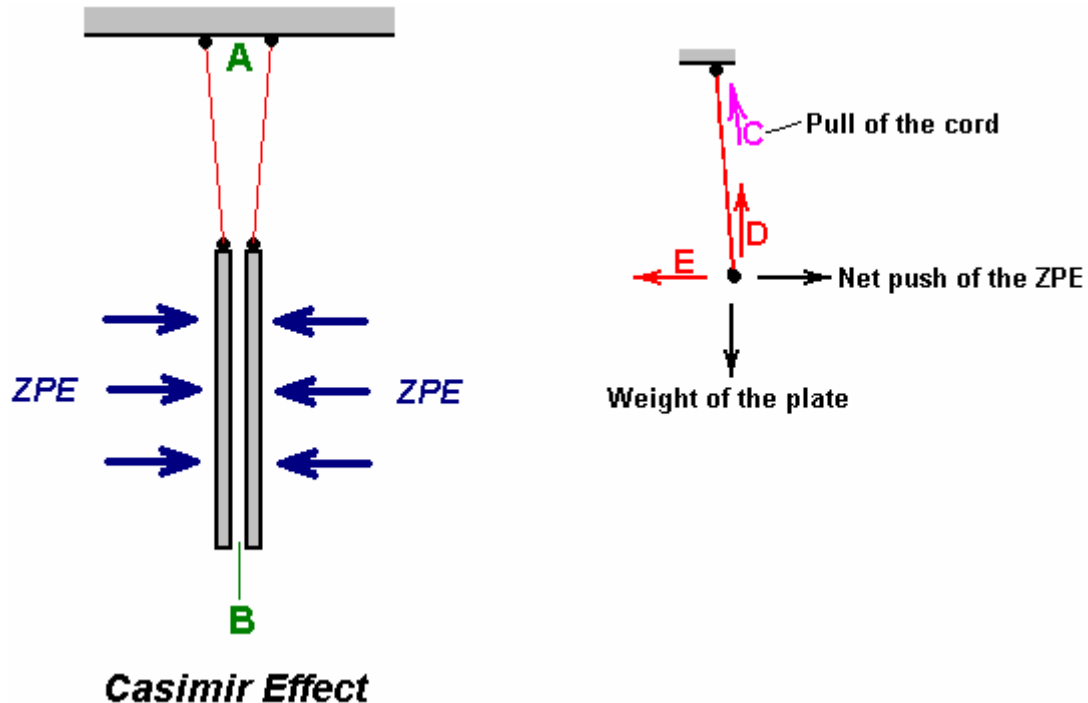

The result is that between the plates, the horizontal force pushing them is unbalanced. Hang just one plate up and the horizontal Zero-Point Energy (“ZPE”) forces coming from the right exactly balance the ZPE forces coming from the left, and the plate hangs vertically below its point of suspension with the supporting cord (shown in red in the diagram above) hangs vertically. But with two plates as shown, the push from the left is reduced very slightly as it passes through the left hand metal plate. This means that there is a lesser push from left to right on the right hand plate. This causes the plate to move very slightly to the left, until the horizontal pull caused by the red cord not being vertical, just balances the difference in the ZPE thrusts on that plate. So, the right hand plate moves slightly to the left.

The same thing happens with the left hand plate. The ZPE thrust coming from the right is slightly reduced as it passes through the right hand plate, and the left hand plate moves slightly to the right until the angled pull of its supporting cord balances the net thrust on that plate. The overall effect is that the gap at point “A” in the diagram is very slightly larger than the gap at point “B”, though the amount is not nearly as great as suggested by the diagram, which has been deliberately exaggerated to show the effect clearly. There is nothing complicated about this, it is just simple common sense. Remember that the pull of the supporting cord “C” is the exact equivalent of a vertical force “D” along with a horizontal force “E”. Here, the vertical force D exactly matches the weight of the plate, and the horizontal force E exactly matches the unbalanced ZPE force (if they did not match exactly, then the plate would move until they did). The further away from the vertical that the plate moves, the greater the resulting horizontal force caused by the pull of the supporting cord.

Tesla expressed this in a very slightly different way in his **Dynamic Theory of Gravity** (1897) which states that all bodies emit microwaves whose voltage and frequency are determined by their electrical contents and relative motion. He measured the microwave radiation of the earth as being only a few centimetres in wavelength. He said that the frequency and voltage were influenced by the velocity and mass of the earth, and that its “gravitational” interaction with other bodies, such as the sun, was determined by the interaction of the microwaves between the two bodies.

If you find the concept of producing a driving force through pushing against the space-time continuum to be difficult to accept, then perhaps you should consider the US Patent granted to Boris Volfson on 1st November 2005. The important thing about this patent (which is crammed full of long words) is not whether or not it presents a realistic mechanism for a practical space drive, but the fact that the US Patent Office in the year 2005, granted the patent after what presumably was careful consideration. With that in view, it is hardly possible to consider Tesla to have been totally confused when he designed (and built) his "electric flying machine" which operated by pulling on the space-time field.

Tesla used high voltage at gigahertz frequencies for his electropulsion system. The propulsion of a vehicle powered by a Tesla drive is by the use of an additional AC generator at the back (which stiffens the space-time continuum behind the vehicle) and a DC 'brush' generator at the front (which weakens the space-time continuum in front, causing the vehicle to be pulled forwards).

Tesla was very astute. He deduced that 'empty space' actually contained:

1. Independent carriers which permeate all space and all matter and from which all matter is made. These carry momentum, magnetism, electricity or electromagnetic force, and can be manipulated artificially or by nature.
2. 'Primary Solar Rays' (starlight) which travel at the speed of light, having frequencies far above X-rays, gamma and UV radiation.
3. 'Cosmic Rays', particles in space propelled by the Primary Solar Rays.
4. X-rays, Gamma rays and UV electromagnetic waves, all of which travel at the speed of light.
5. Ordinary visible and Infra-Red electromagnetic waves which travel at the speed of light.
6. Rapidly varying electrostatic force of enormous potential, emanating from the earth and other gravitational bodies in space.

When we grasp the actual nature of the universe, it becomes clear that we have a much larger range of opportunities for producing usable energy in large quantities and at minimal cost.

Additional information can be found in Boris Volfson's US Patent 6,960,975 of November 2005 "Space Vehicle Propelled by the Pressure of Inflationary Vacuum State" which is reproduced in the Appendix.

If you find the thought of generating a gravitational field, difficult to come to terms with, then consider the work of Henry Wallace who was an engineer at General Electric about 25 years ago, and who developed some incredible inventions relating to the underlying physics of the gravitational field. Few people have heard of him or his work. Wallace discovered that a force field, similar or related to the gravitational field, results from the interaction of relatively moving masses. He built machines which demonstrated that this field could be generated by spinning masses of elemental material having an odd number of nucleons -- i.e. a nucleus having a multiple half-integral value of \hbar , the quantum of angular momentum. Wallace used bismuth or copper material for his rotating bodies and "kinnemassic" field concentrators.

Aside from the immense benefits to humanity which could result from a better understanding of the physical nature of gravity, and other fundamental forces, Wallace's inventions could have enormous practical value in countering gravity or converting gravitational force fields into energy for doing useful work. So, why has no one heard of him? One might think that the discoverer of important knowledge such as this would be heralded as a great scientist and nominated for dynamite prizes. Could it be that his invention does not work? Anyone can get the patents. Study them -- Wallace -- General Electric -- detailed descriptions of operations -- measurements of effects -- drawings and models -- it is authentic. If you are handy with tools, then you can even build it yourself. It does work.

Henry was granted two patents in this field: US Patent 3,626,605 -- "Method and Apparatus for Generating a Secondary Gravitational Force Field", Dec 14, 1971 and US Patent 3,626,606 -- "Method and Apparatus for Generating a Dynamic Force Field", Dec 14, 1971. He was also granted US Patent 3,823,570 -- "Heat Pump" (based on technology similar to the above two inventions), July 16, 1973.

Dr Peter Lindemann gave a lecture at the TeslaTech conference which is very informative and which I would highly recommend. It is available on DVD from <http://www.free-energy.ws/products.html> under the title of "Tesla's Radiant Energy". He makes a number of important points, some of which are repeated here.

We tend to think of the battle for industrial electricity to have been between Thomas Edison's DC system and Tesla's AC system, with Tesla winning. Unfortunately, while true, that is not the full story as Tesla moved on from AC to more powerful systems, and Tesla lost out on those systems, leaving us today, with a workable, but much inferior system. We need to see the overall picture clearly. James Clerk Maxwell produced his famous equations, relating electricity and magnetism (which are actually two faces of a single entity called "electromagnetism"). Subsequently, H.A. Lorentz damaged those equations, throwing away the parts which showed that free-energy was available for use if we knew how to access it.

Our present day position has grown up where, while we realise that "gravity" is 10^{39} times less powerful than electromagnetism, we see "static electricity" as a weak and useless thing which needs to be avoided. The reality is quite different as Tesla points out and demonstrates. Tesla describes "static" and "radiant" energy as being a force which appears to have no ultimate limits at all. That is, it is capable of providing unlimited power. Our knowledge of this power is so inadequate that we believe that power can only flow in a circuit which is a closed-loop and the power flow has to be a stream of electrons. This is most definitely not the case.

The more powerful radiant energy flows like an electrically charged sound wave passing through incompressible air and which can be fed down a single wire without the slightest difficulty. In fact, you can even skip that one wire and use the earth instead, transmitting power with what appears to be no wires at all. The actual, final and most important contest was between closed-loop electricity and single-wire power transmission, and that contest was one which Tesla lost.

The nature of this radiant energy is so different to what we think of as conventional electricity that it is perfectly possible to light a filament light bulb held in one hand, while grasping a single wire in the other hand. When doing this, there is no sensation whatsoever and nothing at all is felt. This has been demonstrated and a video (<http://video.google.com/videoplay?docid=-6461713170757457294>) of that demonstration is on the web at this time.

In his lecture, Dr Lindemann remarks that his understanding of the subject has been helped considerably by the book (<http://www.free-energy-info.tuks.nl/TeslaBook.pdf>) "The Inventions, Researches and Writings of Nikola Tesla" and the book (<http://www.datafilehost.com/download-c74378fc.html>) "The Secrets of Cold War Technology - HAARP and Beyond" which describes some of the early work done by Tesla. He also praises the book "Tesla's Vocabulary for Dummies" which is a joke on his part as there is no such book in spite of his appearing to show some quotations from it in his DVD lecture.

One feature of radiant energy which becomes clear from Tesla's description of it, is that the most useful effects which can be gained from it, start at a DC pulse frequency of 1 MHz which is far higher than experimenters use today. He stresses that we do not actually know the exact nature of electricity and that all of our present day measuring instruments are based on electron theory and so just do not measure radiant energy. In a way, it is a bit like the difference between AM radio and FM radio. Both are perfectly valid and work well, but an AM radio will not receive an FM radio signal and an FM radio will not receive an AM radio signal. Unfortunately, radiant energy is much more powerful than conventional electricity and it is not dangerous like electricity is. It should be noted that Hermann Plauston's very detailed patent - US 1,540,998 (<http://www.free-energy-info.tuks.nl/PatD8.pdf>) is on methods of capturing and using this radiant energy, and he describes any multi-aerial systems which produce a net output of 100 kilowatts as being a "small" system. I don't know about you, but I would settle for a system which produced less than 10% of that fuel-less output.

The best information on radiant energy comes from the writing of Tesla and Dr Lindemann draws attention to one of Tesla's patents, US 685,957 (<http://www.free-energy-info.tuks.nl/PatD37.pdf>) which explain how this radiant energy can be captured and used. Tesla also used a motor design which is effective with this type of energy. The motor has two windings, the first being fed directly and the second one receiving a 90 degree delayed pulse through a capacitor.

One thing that Tesla points out is that there is an incompressible gaseous medium filling the universe and which is composed of particles which are much smaller than hydrogen atoms. Mendeleev who constructed the table of elements indicates quite clearly that there should be two gaseous elements which are lighter than hydrogen, but he did not put them in his table because he did not know what they are.

The Nature of Gravity by Maurice Cotterell.

The comments by Joseph H. Cater later in this chapter include the statement that gravity is electromagnetic radiation of a frequency just below that of infra red. The extract from Karl Schappeller's work, also later in this chapter, states exactly the same thing and the same frequency. The extracts from Joseph Newman's

book, also later in this chapter, point out the effect of electron spin on attraction and repulsion. The document <http://www.free-energy-info.tuks.nl/Cotterell.pdf> is a paper on gravity by the very able Maurice Cotterell, part of which is quoted here:

How Gravity Works

“How Gravity Works” explains how Electricity and Magnetism work together to produce the force of Gravity and in doing so, they reveal the underlying science behind Newton’s equation which he tried in vain to uncover, namely, the reason why Gravity is proportional to the masses of two attracting objects, why it grows weaker in proportion to the square of the distance between them, and the nature of the “Gravitational Constant” which continues to perplex researchers to this day. It explains why all objects accelerate to Earth at 32 feet per second every second. It explains why the atom is comprised of eight orbital shells and why those shells fill with electrons in the way that they do. It explains how permanent magnetism works at atomic level, the nature of so-called ‘Dark Matter’, the reason why spiral galaxies are spiral, why the centre of the Earth is boiling hot and how the Earth’s magnetic field is generated.

Scientists cannot understand why the positive protons on the centre of atoms simply do not spring apart – their positive charges repelling each other. In 1935, a researcher named Yukawa suggested that another substance or particle must exist to ‘glue’ the protons in the nucleus together - a kind of atomic ‘velcro’. But an objector to Yukawa pointed out that if indeed that were the case, then there would have to be two kinds of velcro - a velvet side and a hook side (so to speak). But another researcher pointed out that protons covered in the velvet-side would not stick to other protons covered in the velvet-side, and that protons covered in the hook-side would not stick to other protons covered with the hook-side. So, another researcher pointed out that for such a scheme to work, there would have to be three types of each of the three types. Thus, the crazy field of Particle Physics was born. In the decades that followed, Particle Physicists were granted billions of dollars to find out what makes the atom stable. Since then, they have been searching for more than 300 imaginary sub-atomic particles. The Concise (Oxford) Science Dictionary comments: “... the whole elaborate theory is circumstantial... none of the smaller particles have ever been identified in experiments... the theory does not claim to have been verified”.

Electricity Gravity Magnetism



Cotterell shows that none of the particles actually exist, and more importantly, that none are necessary. To explain why the atom does not spring apart, he returns to firm ground and to the 1930s pioneering work of Ernest Rutherford and James Chadwick and shows that by simply changing the perceived shape of the electron and neutron, the gravitational mechanism is exposed, explaining away the mysteries of the atom and many of the mysteries of the cosmos.

Summary Part 1:

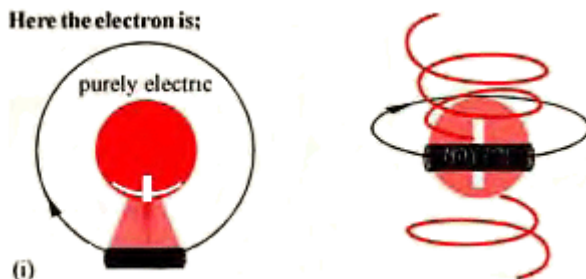

(A) A coil-shaped electron (shown in black) makes the hydrogen atom dynamic [come alive]. The amount of **helically polarised electric field** forced from the poles of the proton is maximum when the electron is horizontal, that is, after 180 or 360 degrees of orbital travel. Shown at the top left is the plan view of a hydrogen atom. The horizontal electron slices through the electric field (shaded pink). A magnetic field is induced into the coil which pushes against the electric field, causing it to topple on it's own axis (like the opposing blades of a windmill) as it orbits the positive proton.

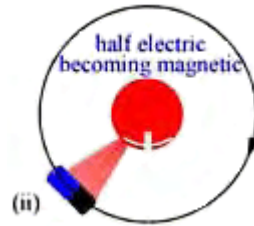

The orbiting coil-like electron sucks energy from the proton causing the proton to compress, release heat and cool rapidly.

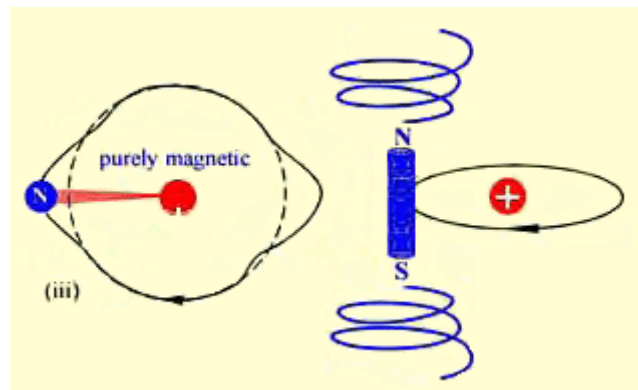

Once the spinning electron-magnet passes the vertical position, the super cold proton sucks in ambient heat and expands rapidly; compression and expansion of the proton results in cyclical changes of capacitance [electric field] proportional to the surface area between the particles.

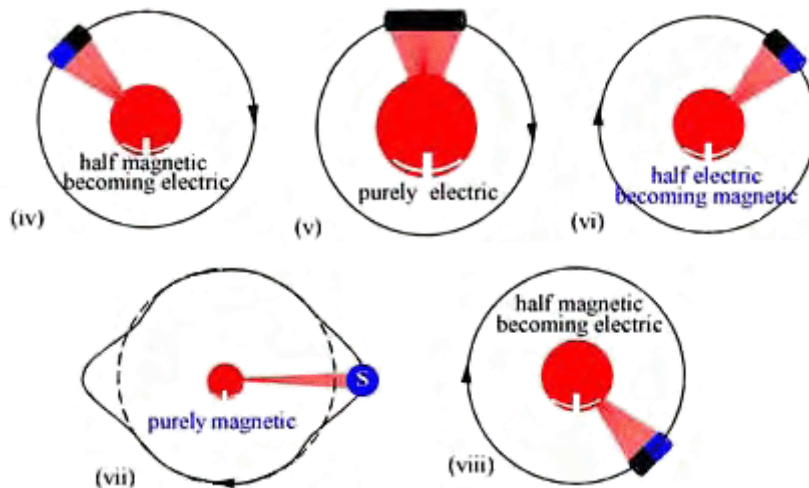

(iii and vii) The **ends** of the electron-magnet radiate maximum amounts of **helically polarised magnetic energy** after 90 degrees and 270 degrees of orbital travel [when vertical]. Hence the magnetic and magnetic radiation is displaced by 90 degrees and the electromagnetic (EM) radiation from the northern sector is displaced in phase by 180 degrees from that of the southern sector.

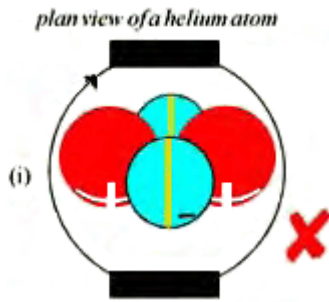

(B) (i) The orthodox view of a helium atom (containing two neutrons) precludes an understanding of gravity - each electron is passive [dead] and the spherically shaped neutrons render the atom unstable. Moreover, the electron is shown as a purely 'electric' particle when in fact it is electric for only half the time, and magnetic for half of the time. **The electron is an 'electromagnetic' particle.**

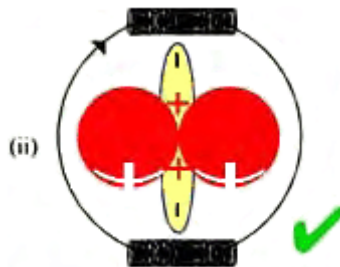

(ii) This new view of the helium atom accommodates a gravitational mechanism - the coil-shaped electrons bring the atom to life and the spike-shaped neutrons make the atom (the contents of the old neutron and the spiked neutron being identical). Supporting evidence: 31/3/08 researchers of the Hohn-Meitner Institute in Berlin announced that "neutrons behave like compass needles" – Science Daily.

(C) hydrogen spins axially and autonomously and so it radiates helically polarised ElectroMagnetic energy into space. [Supporting evidence: 'hydrogen radiates helically polarised EM energy' www.sciencenews.org].

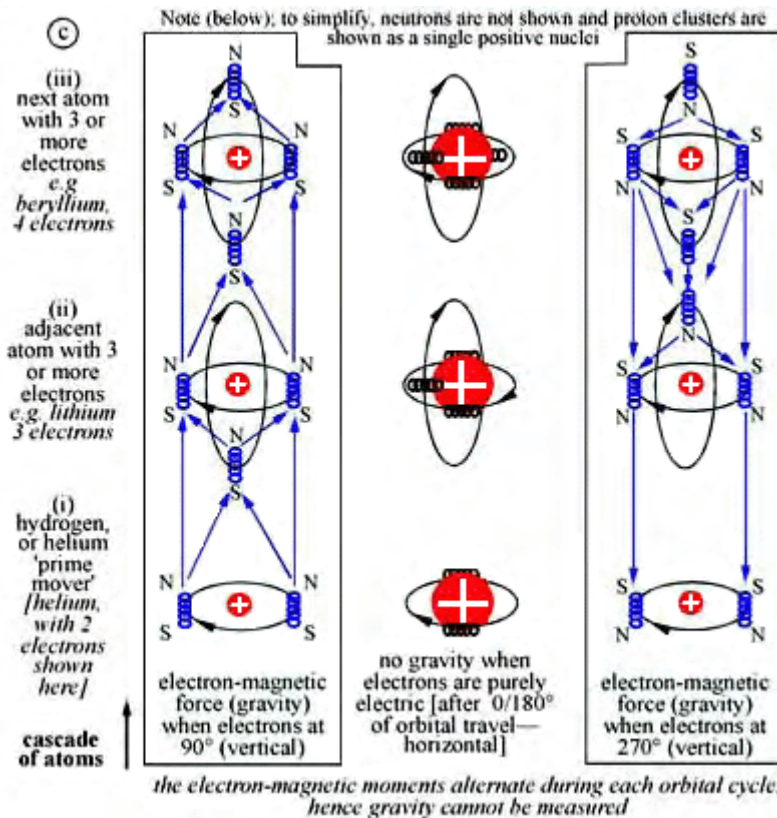

Helium [the only electrically geometrically symmetrical atom to contain spiked neutrons] also spins axially and autonomously and hence, likewise radiates helically polarised electromagnetic energy. In free space, hydrogen and helium are prime movers in the gravitational mechanism. Other atoms cannot **autonomously** radiate helically polarised electromagnetic energy because they do not spin axially or autonomously. However, when helically polarised electromagnetic radiation from hydrogen or helium bombards neighbouring atoms, it causes the nucleus of those atoms to spin in the same direction and, at the same time, causes the orbiting electrons in a cascade of atoms to synchronize their spin. As a result, the magnetic moments of orbiting electron-magnets in a cascade of atoms attract each other. This is the force of Gravity.

Summary Part 2:

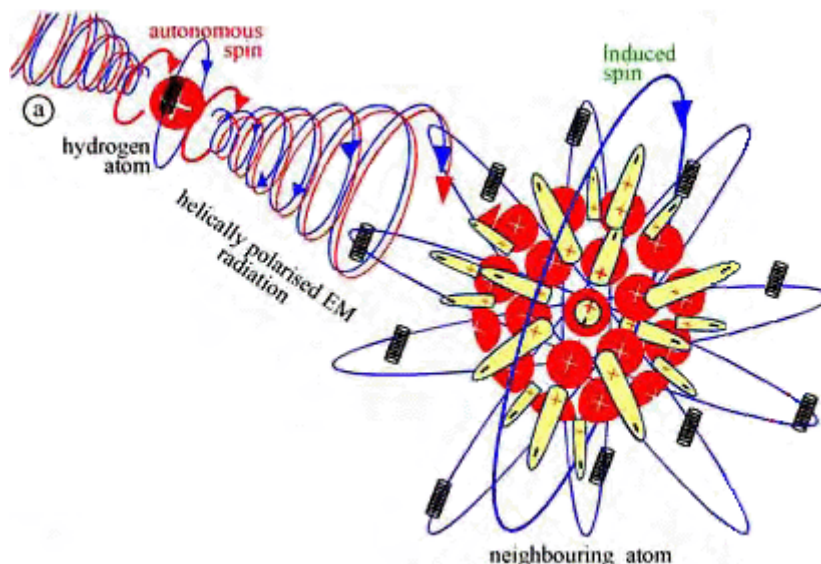

(2A and 2B) The 'Motor Effect'; helically polarised electromagnetic radiation from the hydrogen atom acts upon the negative charges of the neighbouring atom, causing the nucleus and the electron cage to spin axially and at the same time, synchronizes the spin of the electrons in both atoms [Supporting evidence: [Nature 2009;458 \(7238\):610 DOI:10.1038.nature07871](#) (persistent spin helix)]. The mass of the electron is twice that of the neutron-negative charge, hence the torque on the electron-cage is twice that on the neutron-negative charges in the nucleus. Thus, the electron-cage spins faster than the nucleus.

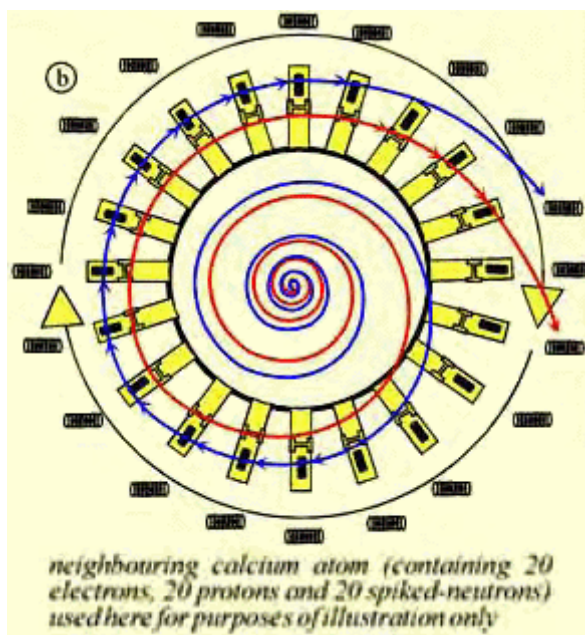

(2B) The 'Generator Effect'; orbiting electrons in the neighbouring atom now 'generate' helically polarised electromagnetic radiation. The power of the atomic 'generator' is proportional to the differential speed between the nucleus and the electron cage and to the number of orbiting electrons (atomic mass).

Electromagnetic output is a function of the number of electrons [atomic mass] ('g') AND of the difference in rotational speed between the nucleus and the electron cage ('f').

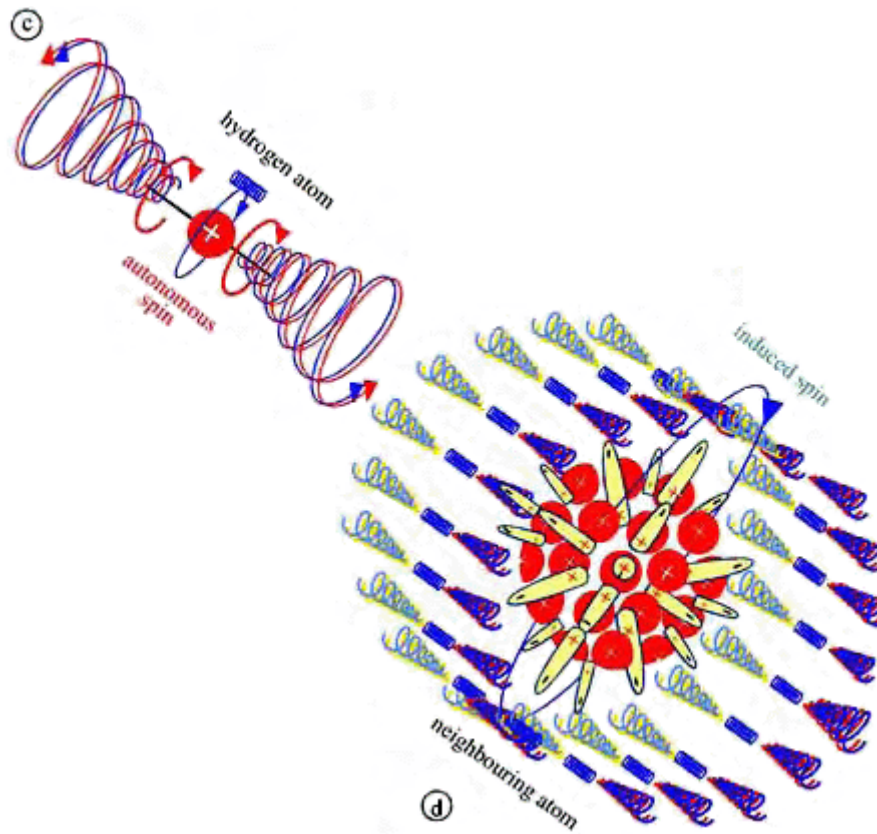

(2C) Gravity radiation from the hydrogen atom bombards neighbouring atoms sucking them towards the source of the radiation. [Here, to facilitate explanation, the magnetic wave (shown in blue) is shown radiating from the nucleus whereas in actuality, it radiates from the orbiting electron].

(2D) The corkscrew-style electromagnetic radiation from the neighbouring atom now, likewise, sucks nearby atoms towards itself. Both atoms suck in the same direction, thus gravity from the Sun and the Moon pull in the same direction. [To facilitate explanation, the electric waves (shown in red) are shown radiating from orbiting electrons].

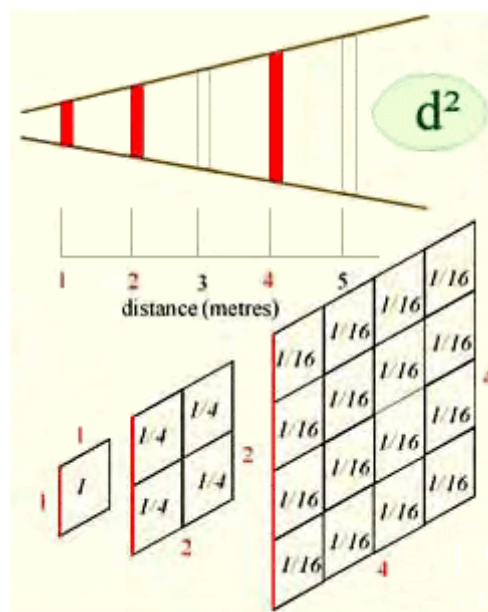

(2E) As gravity radiation propagates and moves away from the atom, it decreases in field strength [per metre squared]. For every unit of distance travelled, the radiated energy diverges geometrically. This causes the radiated energy to reduce by the square of the distance travelled (“d²”). The numbers inside the square in the diagram above show the field strength of the radiating electromagnetic energy in volts per square metre. [Squares are used here just for illustration purposes as the diverging wave is actually conically-helical as seen in Figure 2F].

(2F) The frequency of the helically polarised electromagnetic radiation from the Earth remains constant. However, as **m** approaches **M**, the spiralling electromagnetic radiation accelerates the differential rotation between each atomic nucleus and electron-cage of which **m** is made. As a result, the ‘relative’ atomic frequency increases and hence the output of the ‘atomic generator’ increases, uniformly increasing the attracting electromagnetic Force between **m** and **M** in accordance with a square-law scale as **m** proceeds along the electromagnetic spiral. **M** thus attracts **m** with square-law [d²] uniform acceleration. In the diagram on the right, **m** is shown spiralling towards **M** with the electromagnetic wave stationary, but in reality, **m** approaches **M** in a straight line as the wave spirals across **m**.

(2G) Hence Isaac Newton’s equation for the force of gravity; where the force is proportional to the masses (**m** and **M**) of the two attracting bodies and the strength of the force decreases inversely with the square of the distance between them (d²).

$$F = GmM/d^2$$

G is Newton’s gravitational constant **6.67428 x 10⁻¹¹ N m² kg⁻²** - the instantaneous alternating magnetic force between any two electron-magnets in neighbouring atoms.

Maurice Cotterell gives a more advanced and in-depth explanation of this process in his latest book “FutureScience” in which the introduction says:

The 12 great mysteries of Physics

You can be forgiven for believing that Isaac Newton discovered the force which makes apples fall to the ground, but he did not. He simply gave the force (F) a name (“Gravity”) and noted that the strength of the force, whatever it might be, depends on the size of the Earth (Mass M₂). He also figured out that the strength of force on the apple depends on how far away the apple is from the Earth to begin with and he noted, like Galileo before him, that as an apple falls it speeds up and travels faster and faster until it hits the ground.

At first, Newton set down the relationship between the force and the masses in a shorthand way (a formula) saying that F (the strength of the force) could be found by multiplying m₁ by M₂ and then by dividing the result by the square of the distance between them (d²). There was just one problem: every time he did the calculation he finished up with the wrong answer. He eventually discovered that the only way to get the right answer was to multiply the wrong answer by ‘667 billionths’. He did not know where this tiny amount of force came from, but just like he had done with Gravity, he gave the mysterious number a name – “the Gravitational Constant” **G**. This made his formula $F = G \times m_1 \times M_2 / d^2$. It is hard to believe that since then, that is, for more than 350 years, still no-one understands what gravity is or what causes it or why we have to multiply the wrong answer by G to get the right one. To this day, no-one understands what G is or even where it comes from. That’s how sophisticated we are. No-one understands why objects fall to the ground.

The second most embarrassing problem for modern Science is that no-one understands why positive charges in the middle of atoms simply do not just spring apart which is what you would expect, given that positive repels positive. To overcome the contradiction, physicists decided that the positive charges must be glued-together in some way and so, for the past 75 years they have been searching for the ‘glue’ or more precisely, more than 300 types of glue – but as yet have not found any.

Also, no-one understands (given that positive attracts negative), why the orbiting negative electrons of atoms do not simply get sucked into the positive bits in the middle of the atom. They just ‘cannot understand it’.

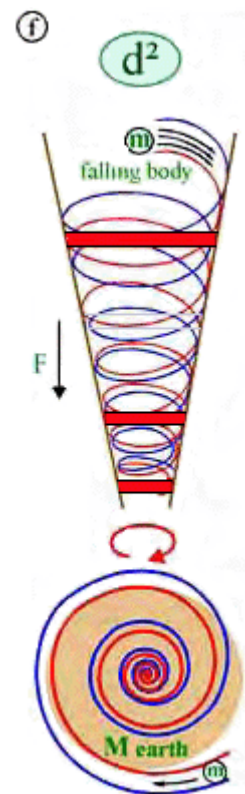

When you place a magnet on the door of a refrigerator, you probably imagine that scientists understand how a magnet actually works, but they do not. As far as they are concerned, it seems to work by *magic* so they gave it the name *magnet*.

Switch on the light and you no doubt take it for granted that the people who supply the electricity understand how it works, but they do not. Physicists are pretty sure that an electrical current is simply the movement of atomic negative charges along a wire. The problem is that no-one understands why, whenever a current flows, a magnetic field appears around the wire.

When they look skywards at night, astro-physicists cannot understand what makes the stars cluster together into galaxies, because their calculations contradict what their eyes can see. To overcome this, they say that there must be other sources of gravity out there, like planets and dust which cannot be seen because it is dark. So they named their fantasy planets 'dark matter', at least for the time being, until they can figure out why their calculations do not make sense. Neither can they understand why stars spiral into galaxies, but they cling to the hope that when (or if) they understand how gravity actually works, that the reason for the double-spiral of galaxy formation will become clear.

"FutureScience" explains in a simple way, how Electricity and Magnetism work at atomic level, and how they work together to produce the force of Gravity and in so doing, reveal the underlying science behind Newton's equation – the underlying science which he tried in vain to uncover – the reason why Gravity is proportional to the masses of the two attracting objects, why it grows weaker in proportion to the square of the distance between them, and the nature of the mysterious 'Gravitational Constant' which continues to perplex researchers to this day. It explains why all objects accelerate to Earth at 32 feet per second every second. It explains why the atom is comprised of 8 orbital shells and why the shells fill with electrons the way that they do. It explains the nature of so-called 'dark matter', the reason why spiral galaxies are spiral, why the centre of the Earth is boiling hot, how the Earth's magnetic field is generated, how to generate gravity waves, how gravity waves can be used to produce unlimited quantities of free energy, how to generate antigravity waves, how antigravity waves can be used to de-couple hydrogen bonds in water, separating hydrogen from oxygen and providing unlimited supplies of free hydrogen to fuel hydrogen-powered cars, and how antigravity radiation can be used to cause the disintegration of matter in water and living tissue (phasor weapons technology).

The book goes on to explain the cause of the Sunspot cycle and how the Sun affects life on Earth: the cause of global warming and global cooling, how the 289-day spinning Sun regulates fertility in females, how the Sun's radiation causes 12 types of genetic mutations which result in 12 types of personality (sun-sign astrology), how sunspots cause schizophrenia, how the Sun controls bio-rhythms and our day-to-day behaviour, how the Sun causes catastrophe cycles and the rise and fall of civilizations, and how mobile phones and power lines cause cancer.

How the discoveries were made

In 1935, in an attempt to explain why protons in the centre of atoms do not simply spring apart, a researcher named Yukawa suggested that another substance or particle must exist to 'glue' the protons in the nucleus together - a kind of atomic 'velcro'. But an objector to Yukawa pointed out that if indeed that were the case, then there would have to be two kinds of velcro - a velvet side and a hook side (so to speak). But another researcher pointed out that protons covered in the velvet-side would not stick to other protons covered in the velvet-side, and that protons covered in the hook-side would not stick to other protons covered with the hook-side. So, another researcher pointed out that for such a scheme to work, there would have to be three types of each of the three types. Thus, the crazy field of Particle Physics was born. In the decades that followed, Particle Physicists were granted billions of dollars to find out what makes the atom stable. Since then, they have been searching for more than 300 imaginary sub-atomic particles. The Concise (Oxford) Science Dictionary comments:

"... the whole elaborate theory is circumstantial... none of the smaller particles have ever been identified in experiments... the theory does not claim to have been verified".

FutureScience shows that none of the particles actually exist and, more importantly, that none are necessary. To explain why the atom does not spring apart, the Author returns to firm ground and to the 1930s pioneering work of Ernest Rutherford and James Chadwick and shows that by simply changing the perceived shape of the electron and the neutron, the gravitational mechanism is exposed, explaining away the mysteries of the atom and many of the mysteries of the cosmos. The book is aimed at the general reader with no prior knowledge of Science and it uses many illustrations to convey the concepts simply and concisely.

Maurice Cotterell's web site is <http://www.mauricecotterell.com/>

Maurice also comments on the recent Cold fusion generator development of Rossi as follows:

E-Cat generator **not** 'cold fusion'

The Energy Catalyzer (also called E-Cat) is a purported **cold fusion** or Low-Energy Nuclear Reaction (LENR) heat source built by inventor Andrea Rossi with support from physicist Sergio Focardi. An Italian Patent, which received a formal but not a technical examination, describes the apparatus as a 'process and equipment to obtain exothermal reactions, in particular from nickel and hydrogen'. Rossi and Focardi say the device works by infusing heated hydrogen into nickel, transmuting it into copper and producing heat. An international Patent Application has received an unfavorable International preliminary report on patentability because it seemed to '**offend against the generally accepted laws of physics and *established theories***' and to overcome this problem the Application should have contained either experimental evidence or a firm theoretical basis in **current** scientific theory. (<http://www.peswiki.com>)

FREE ENERGY?
YES
but it's not 'Cold Fusion'

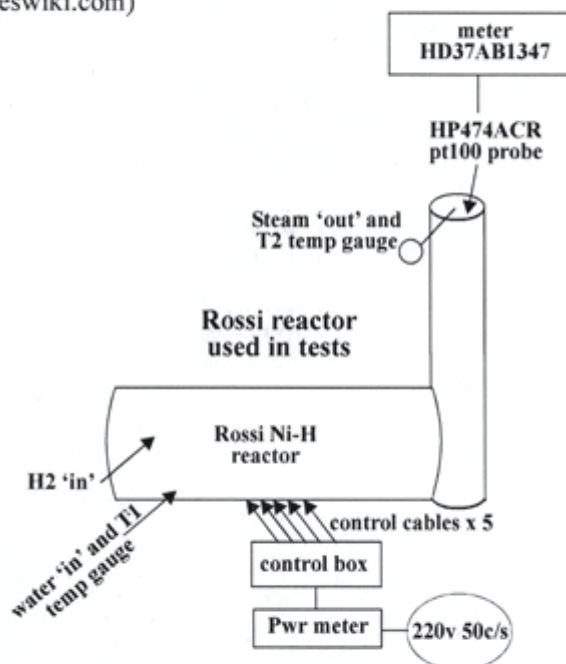

How they think it Works: The Energy Catalyzer works—they believe—by placing nano to micro sized particles of nickel powder in a reactor along with pressurized hydrogen gas and special undisclosed (for proprietary reasons) catalysts. When the contents of the reactor is heated (using a series of resistors in the reactor) to approximately 400 to 500° C., *nuclear reactions* start taking place. The strength of the reaction can be changed by varying the pressure of the hydrogen in the reactor. The output energy can be up to 400 times the input energy. No precious metals or radioactive substances are placed in the reactor. After the reactor is turned-off the reactor can be opened and no radiation can be detected. The process appears to transmute nickel into copper and trace amounts of other elements such as zinc. **It will not work with deuterium (heavy hydrogen)—but they don't know why.**

if it's not 'Cold Fusion', how does it really work?'

...it works by '**Periodic Scaling**' →

How to generate gravity waves, and free energy, using 'Periodic Scaling'

ambient heat and light

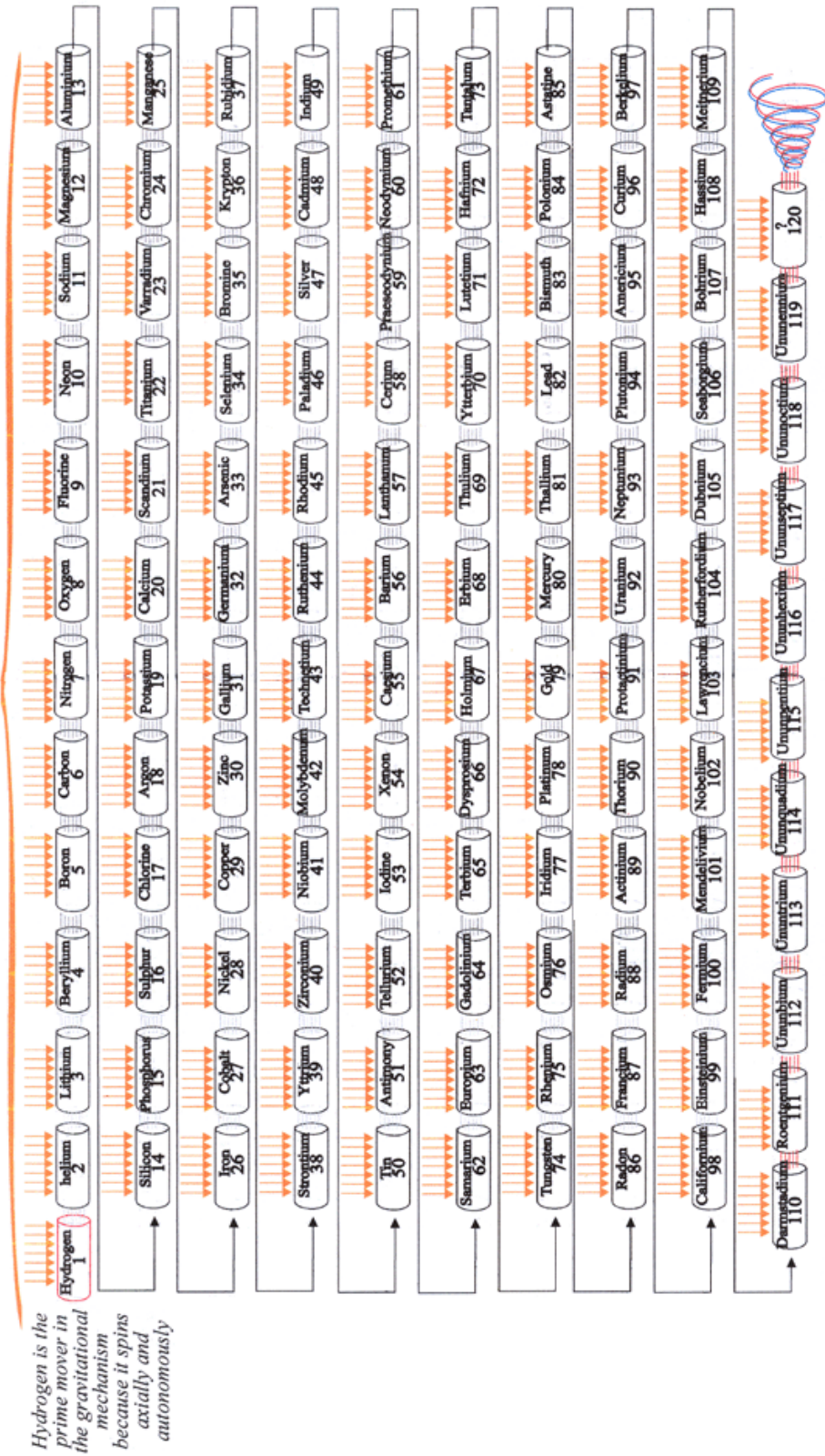

Fill each of 120 containers with one each of the elements and align the containers in a straight line in rising atomic number order. How does it work? Gravity waves from the hydrogen atoms in the hydrogen container will bombard the container next in line containing helium. The helically polarized electromagnetic gravity waves from the hydrogen container will act upon the spiked-neutrons in the helium atoms causing the helium atoms to spin axially in the same direction. The helium atoms will now generate and radiate helically polarized gravity waves, sucking-in ambient heat to fuel the process. In this way ambient heat is converted to gravity waves and more heat. Helically polarized gravity waves from the helium atoms will act upon the spiked-neutrons in the lithium atoms causing those atoms to spin axially in the same direction. The lithium atoms will now generate and radiate helically polarized gravity waves, again, sucking-in ambient heat to fuel the process. This sets up a chain reaction along the line of containers; hydrogen, the prime-mover, activates every atom in the chain. Containers along the chain will become increasingly hotter and massive amounts of gravitational energy and heat will radiate from the end of the chain following atom 119, ununennium. [from *FUTURESCIENCE—forbidden science of the 21st-century* by Maurice Cotterell]

Note: the line of containers will be influenced by gravity waves from the Earth and so should be stacked vertically; silo-like, with hydrogen uppermost. Water may be used in place of hydrogen, and dangerous elements may be omitted, at a cost to efficiency.

The E-Cat generator uses ‘Periodic Scaling’ to generate heat in the same way; the hydrogen fuel, used in the process, sucks-in ambient heat and converts the heat to gravity waves—that’s why liquid hydrogen is the most effective super-coolant. The corkscrew-style electromagnetic gravity waves from the hydrogen atoms then excite the nickel atoms causing the nickel to get hotter. The hydrogen fuel then sucks-in more heat *from the nickel* and radiates more gravity waves that again bombard the nickel. Some of the fuel is consumed in the process. This cumulative excitation continues until the availability of heat in the ambient air, and nickel, is constrained by energy transfer considerations.

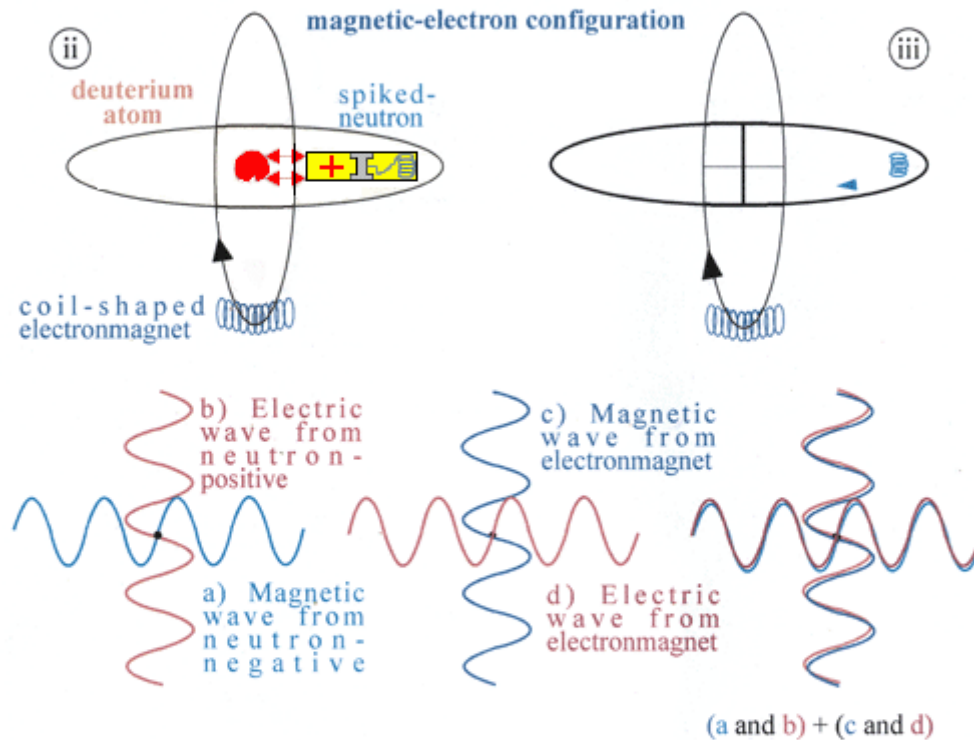

Figure 7 (in *How Gravity Works* [see www.MauriceCotterell.com]) showed how the first two atomic orbital shells are offset by 90°. In this case, the neutron-negative occupies the first *virtual* orbital ‘radius’. The electromagnet orbit must therefore be offset by 90°, as shown. Because of this, the electric wave from the neutron-positive clashes with the magnetic wave from the orbiting electromagnet, and vice-versa, and the two electromagnetic waves cancel. Hence, deuterium cannot radiate gravity waves.

here’s the ‘smoking-gun’; the E-Cat generator will not work with deuterium [heavy hydrogen]—because deuterium cannot radiate gravity waves

proof, if proof were needed, that the process must work by ‘Periodic Scaling’

www.MauriceCotterell.com

© M.Cotterell 2013

John Searle’s Permanent Magnet Drive/Generator.

Professor John R.R. Searle of Britain developed an electrical generation system based on two rings of magnets being spun relative to one another. The magnet orientations oppose each other to produce a magnetic splatter field.

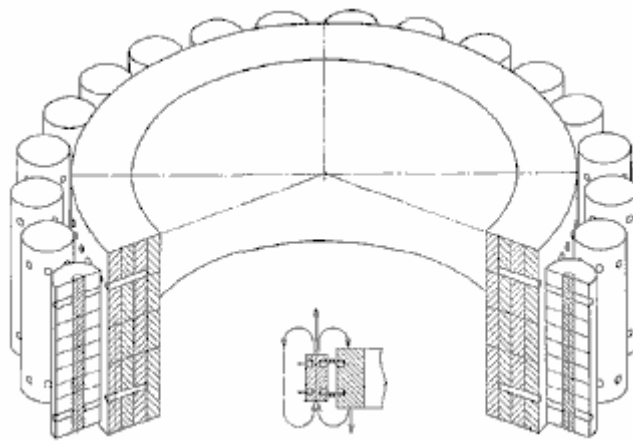

The outer magnets in the diagram above are referred to as “rollers”. When three rings of rollers are placed one inside the other, then the outer ring rotates of its own accord, without any external power being applied. If pick-up coils are placed around the outside, then electrical current is generated with a COP of infinity. The method of imprinting the necessary magnetic pattern on both the rollers and the stators is a difficult and expensive process.

Dr. Terry Moore has recently built a replication model of this Searle technology and his model video is available at <http://www.youtube.com/watch?v=bb3N1epMG7A>. The Searle device also demonstrates a gravitic effect and John has built what would loosely be described as a “flying disc” using this technology. If high voltage is applied to the device when it is rotating, then a surrounding corona develops and strong upward electrogravitic forces are generated.

Dave Lawton’s Gravity-Wave Detector.

It has been reported that Nikola Tesla made a device which allowed him to hear sounds at great distances. I have never seen any details of the circuitry used by Tesla. However, Dave Lawton has produced such a device, and he reports that he could hear conversations taking place four and a half miles away from him. Interestingly, the sounds from that distance were also travelling through a solid stone wall some three feet thick. The circuit for this device is described in this document.

In my opinion, the device is not picking up audio signals in the manner of a conventional microphone where air pressure waves vibrate a transducer, creating an electrical signal which is then amplified. The interesting thing is that it is distinctly possible that some other mechanism is coming into play here. This opinion is supported by the fact that Dave’s circuit is an upgraded version of a monopole gravity-wave detector. Dave used this device to record the “sound” of the Shumaker-Levy comet colliding with Jupiter.

The circuit shown here is quite conventional electronically speaking, comprising of two 741 operational amplifiers connected as a two-stage amplifier. The unusual feature is where a small amount of white noise is being fed into the microphone input:

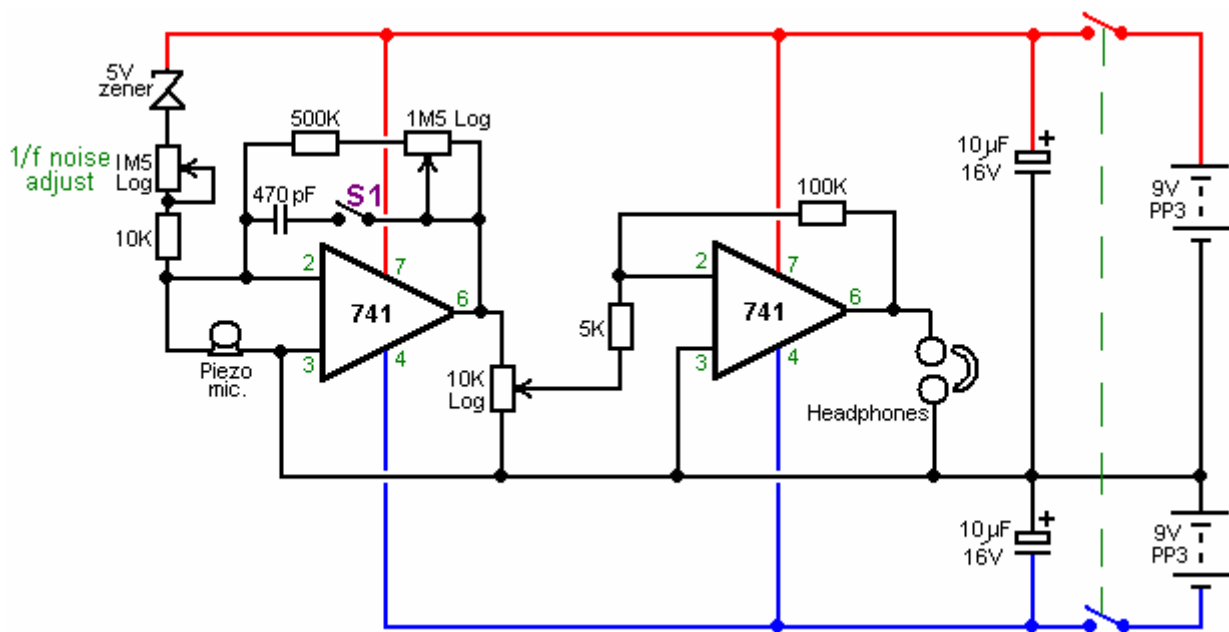

The white noise is generated by the 5-volt zener diode. The level of this white noise component is controlled by the 1.5 megohm variable resistor plus the 10K fixed limiting resistor. While the range of these two components is 10K to 1.501 Meg. the working setting is normally very high and so only a very small amount of white noise is fed into the input of the first 741 op. amp. to modify the microphone input.

The adjustment of this injection of white noise is the main control of this most unusual circuit, and it has been found that when the setting is just right, the circuit has the feel of a public address system just about to go unstable from positive feedback. The unit build looks like this:

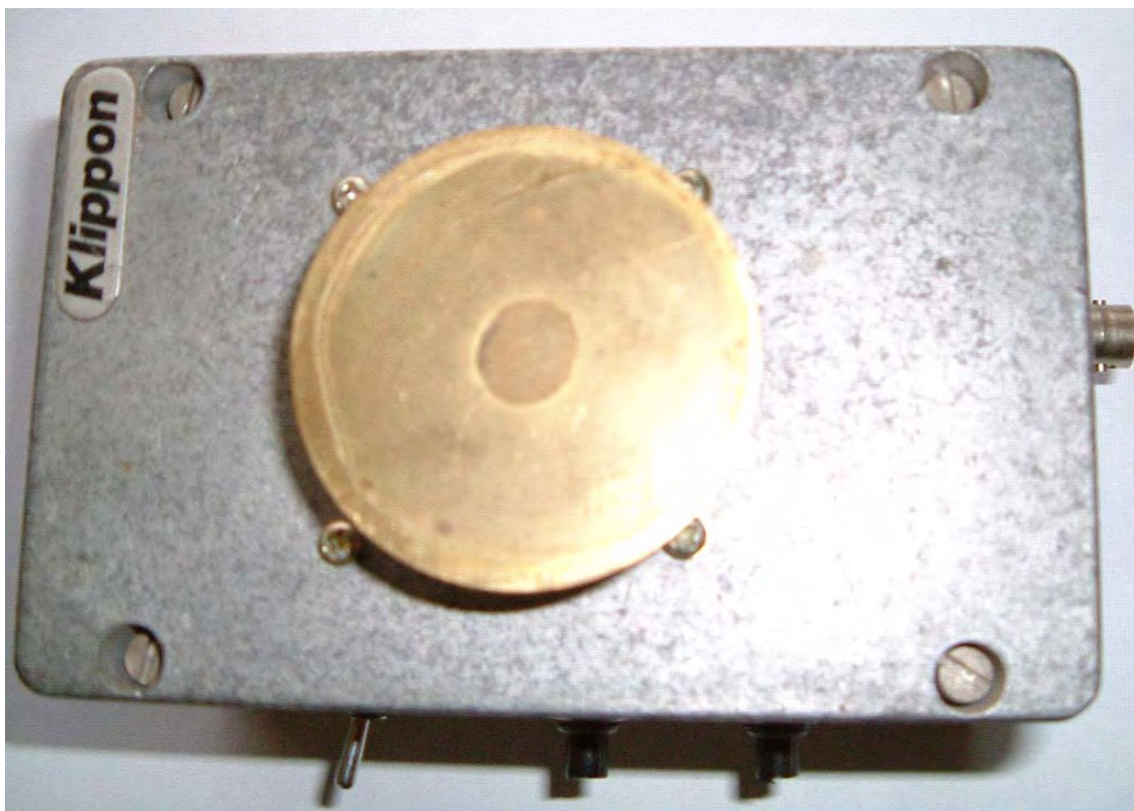

The theory of operation was put forward by Gregory Hodowanec in the April 1986 issue of the Radio-Electronics Magazine, where he puts forward the theory that the source of noise in electronic devices is caused by gravitational waves and he suggests that there are monopole gravity waves. This does not oppose the gravity waves predicted by Einstein. Gregory views these monopole gravity waves as being much stronger than those suggested by Einstein, and consequently, much easier to detect.

He also suggests that monopole gravity waves have been seen for many years and have been described as “low frequency noise” signals or “flicker noise”. These signals have also been called Microwave Background Radiation, supposedly caused by the “Big-Bang” though this cause is disputed by some.

Gregory views our universe as a finite, spherical, closed system, i.e. a black body. Monopole gravity waves propagate in Planck time so their effects appear everywhere almost simultaneously. Gravity wave energy can be imparted to ordinary objects. So it is suggested that the fact that a fully discharged electrolytic capacitor can develop a charge when disconnected from all circuitry, is down to the interaction of the capacitor with monopole gravity waves.

Gregory suggests the following circuit for examining monopole gravity waves:

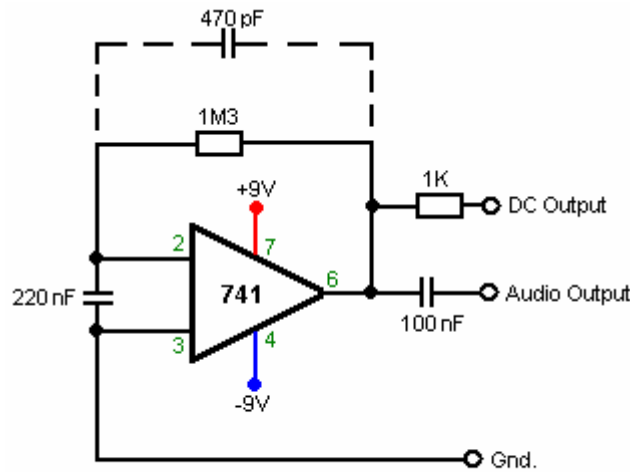

Gravity Wave Detector

Details of this and the theory can be found at www.rexresearch.com/hodorhys/remag86/remag86.htm Dave has taken that circuit and extended it substantially to give added gain plus a controlled feed of white noise, without relying on the characteristics of a capacitor, capacitors being notoriously variable in precise characteristics.

The unit is operated by turning the gain up until the circuit just reaches self-oscillation, and then backing the gain off very slightly. The white noise source is then adjusted until the unit is producing a somewhat echoing quality to the sound. The result is a device which has unusual characteristics. The circuitry is so simple and cheap, that you can easily try it out for yourself.

Butch Lafonte’s Motor/Generator.

Butch has designed an intriguing Motor / Generator system based on the balancing of magnetic and electrical forces. This clever design operates according to the following statements made by Butch:

1. If a magnet is moved away from an iron-cored coil, it generates a voltage:

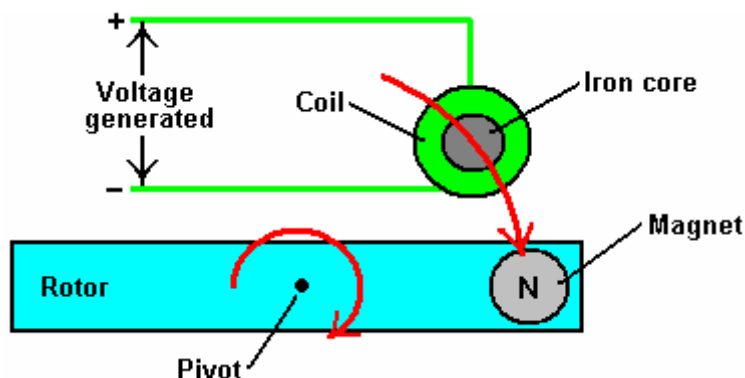

The voltage generated for any given magnet and speed of movement, is directly proportional to the number of turns of wire which make up the coil.

2. If a magnet is moved away from an air-cored coil, it also generates a voltage. However, the big difference is that the voltage is of the opposite polarity. In other words, the plus and minus connections are swapped over:

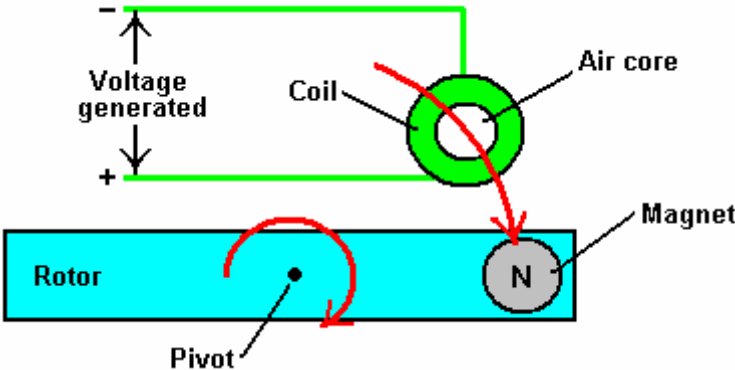

Again, the voltage generated for any given magnet and speed of movement, is directly proportional to the number of turns of wire which make up the coil.

So, if these two arrangements are joined together, they produce a system where the voltages cancel each other exactly, provided that the number of turns in each coil are adjusted to produce exactly the same voltages. The mechanical attraction and repulsion forces also balance, so the circuit can be arranged to have no net effect when the rotor is rotated:

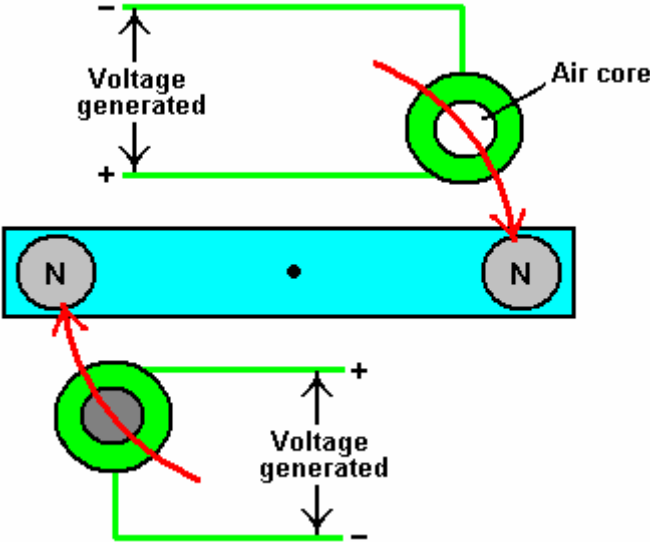

It follows then, that this motor arrangement could be introduced into an existing circuit without affecting the operation of that circuit. The arrangement would look like this:

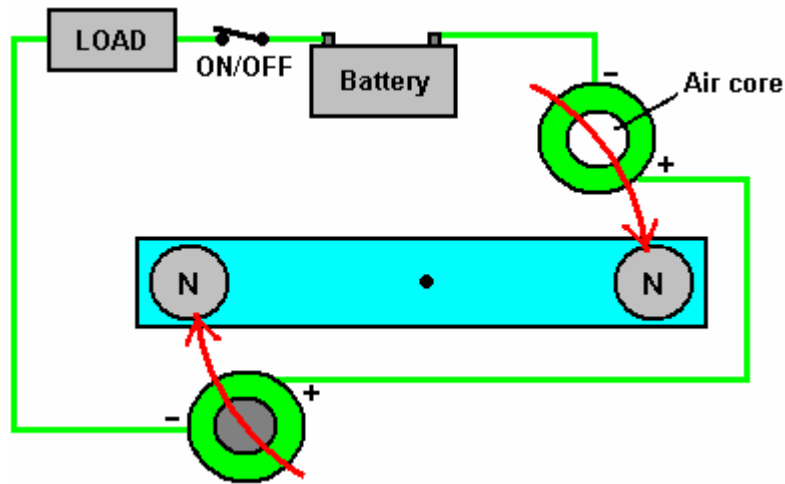

Here, there is no net electrical or magnetic drag on the rotor as the magnets move away from the coils. The battery supplies current to the load in the normal way and rotor arrangement has no effect on the operation of the circuit.

However, when the rotor reaches 100° or so, past the coils, the On/Off switch can be opened. This leaves the rotor in an unbalanced condition, with there being an attraction between one magnet and the iron core of one coil. There is no matching repulsion between the other magnet and the air core of the other coil. This produces a rotational force on the rotor shaft, keeping it spinning and providing useful mechanical power which can be used to generate additional power. This extra mechanical power is effectively free, as the original circuit is not affected by the inclusion of the rotor system.

From a practical point of view, to give high rotational speed and long reliable life, the On/Off switch would need to be an FET transistor with electronic timing related to the rotor position.

There is no need for the rotor to have only two magnets. It would be more efficient if it had four:

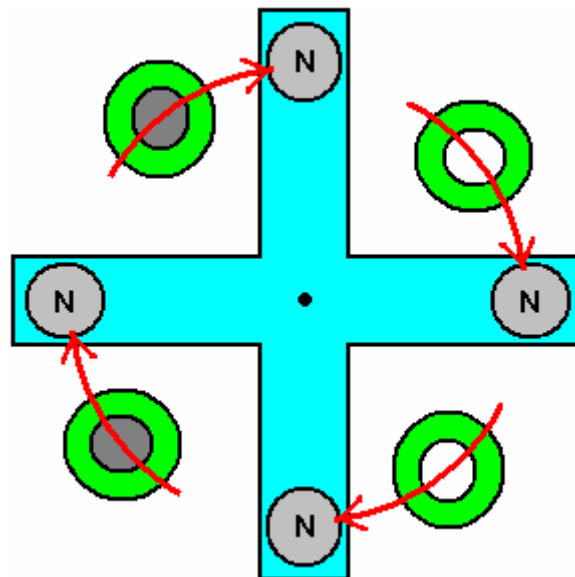

Or better still, eight:

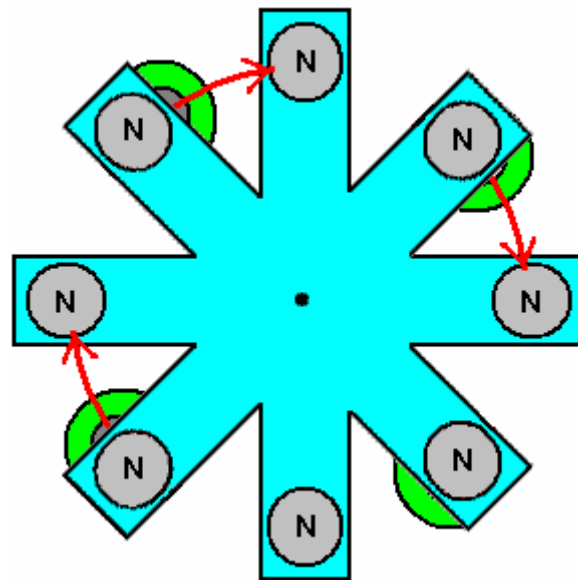

And if you are going to have eight, there is no need to have the V-shaped cut-outs which just create turbulence when spinning, so make the rotor circular:

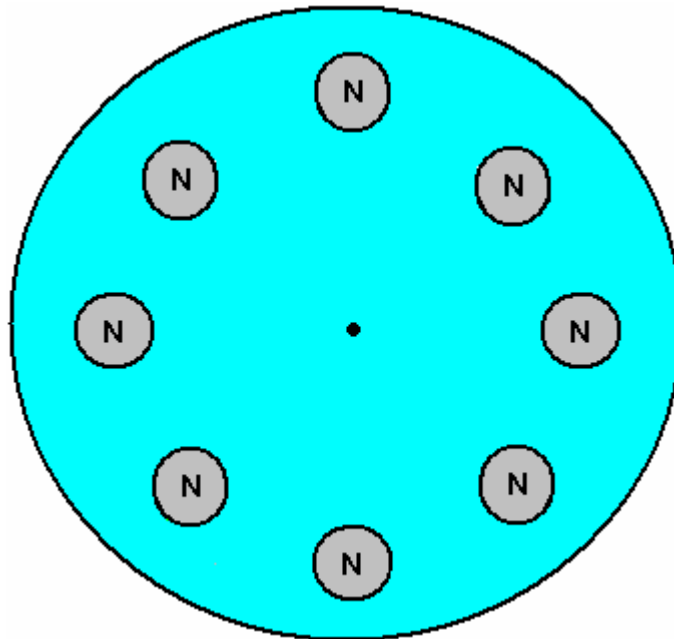

And the stator supporting the coils matches the rotor:

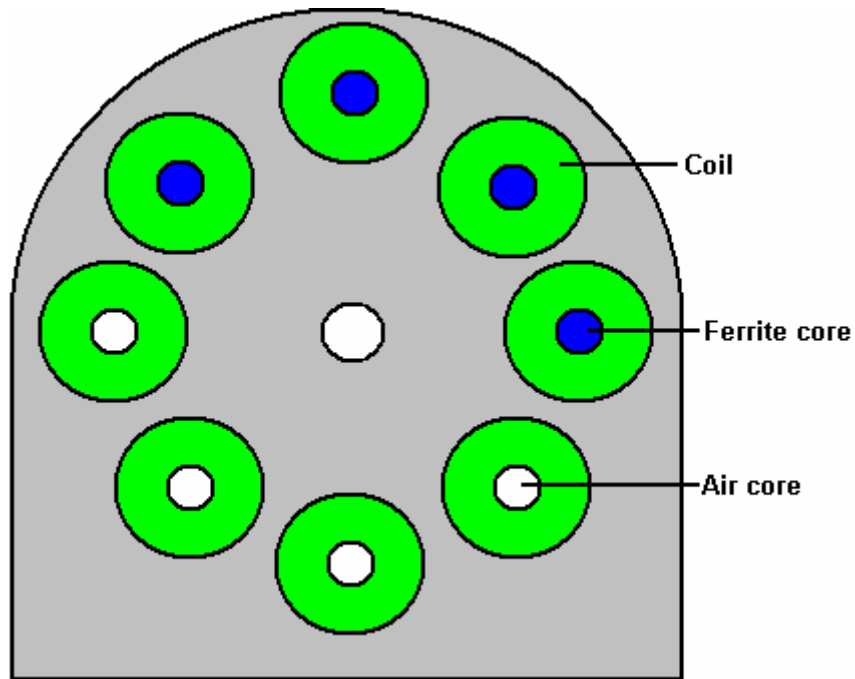

Ferrite is a better material for the cores of the coils. The stators go each side of the rotors and the hole in the middle of the stators is to give clearance for the shaft on which the rotors are mounted:

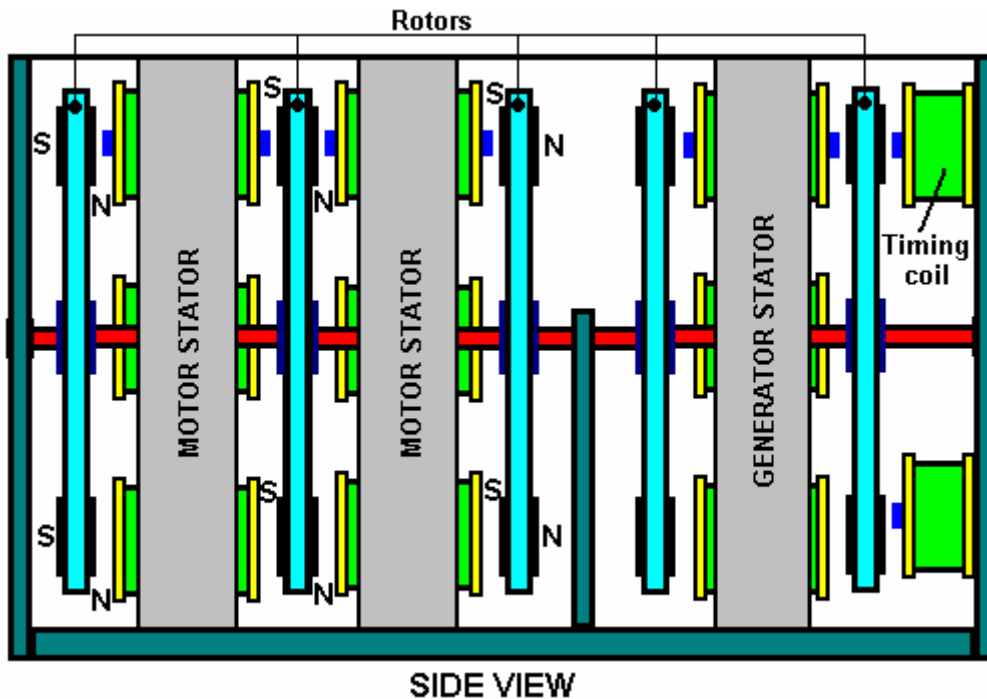

A system of this type needs accurate timing which is solely related to the rate of rotation. This is best arranged by the use of a bistable multivibrator as described in the Electronics Tutorial of Chapter 12. You will notice the two Timing Coils shown at the right hand side of the diagram above. These are used to toggle the bistable On and Off and they are adjustable in position so that both the On and the Off can be set very precisely. The output of the bistable is set to switch an FET transistor On and Off to give circuit switching which is not affected by either the switching rate or the number of times the switch is operated.

The Rotor / Stator combination can be wired to act as either a driving Motor or an electrical Generator. The difference is the addition of one diode:

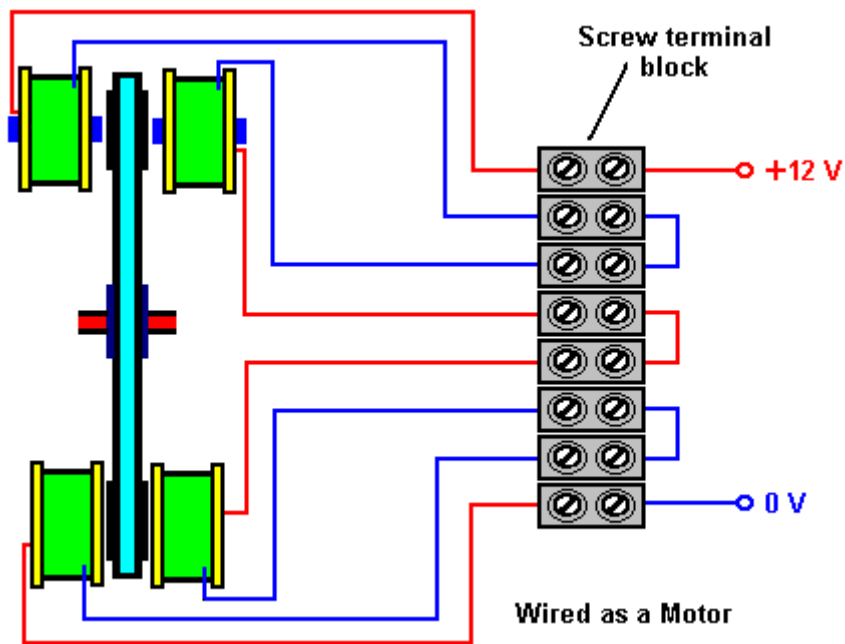

With this arrangement, for each rotor, all four pairs of Cored coils are wired in parallel across each other, and all four Air-cored coils are wired in parallel across each other. To improve the clarity, the above diagram shows only one of the four pairs, but in reality, there will be four wires coming into the left hand side of each of the screw terminals.

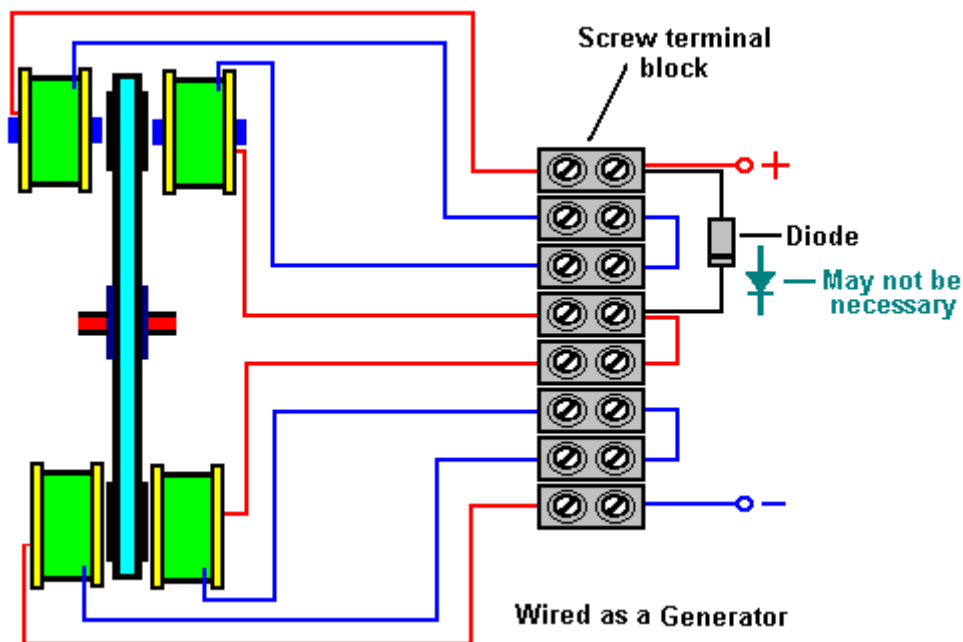

In the case of the Generator arrangement, you have the option to connect each of the four pairs in parallel as in the Motor arrangement or to connect them in series. Connected in parallel, the coils can sustain a greater current draw, while if connected in series, they provide a higher voltage. The voltage could be further increased by increasing the number of turns on each coil.

Joseph Newman's Motor.

Joseph Newman is a man who impresses me. He performs experiments, reports the results and then bases theoretical conclusions on the results of his own experiments. This is the true scientific method.



Joseph has been granted a patent and he has written a book. I would recommend that you buy a copy of his book and help support his work by doing that, but unfortunately, as I understand it, the printing plates for the book were destroyed in a fire and printed copies of his book are effectively unobtainable. You can download a .pdf version from the <http://www.free-energy-info.tuks.nl/> web site but please be aware that the overall file size is 100 Mb and so the download will take quite some time. A background download can be had from <http://www.mediafire.com/view/?oe5obw6offoqfs3> or the alternative <http://www.filefactory.com/file/b4g6b3d/Newman.pdf> link while the link to Joseph's own web site is <http://www.josephnewman.com/>.

In very brief outline, Joseph has built a motor which can access free energy. He has a theory about where the excess energy is coming from and how it is acquired by his designs. He has also built a large stationary motor to demonstrate his theory and he has built a motor into a car. The car engine runs on very minor battery power. Joseph's patent is included in the Appendix.

With the kind permission of the Joseph Newman organisation, I am going to attempt to introduce you to the important scientific conclusions reached by Joseph and the Energy Machine which he designed and which is based on those conclusions. Joseph has a keen enquiring mind and thinks things through for himself rather than blindly accepting everything he is told. This description contains illustrations and wording taken from parts of Joseph's book published in 1984, and I should like to express my thanks for being given permission to use this material.

Joseph Newman's motors all consist of a very powerful permanent magnet which rotates or oscillates in or near a coil with a very large number of turns of copper wire. The coil is energised by a battery pack, and the magnetic field produced by the coil provides the force needed to move the permanent magnet. A mechanical switching device or "commutator" reverses the direction of current flow through the coil every half cycle, and in some models, it also cuts off the current input between the current reversals.

The main difference between Joseph's designs and previous motors is one of scale as Joseph uses very large coils and very large ceramic magnets weighing up to 700 pounds. His smaller motors use powerful rare earth magnets and the coils are wound with 100,000 turns of copper wire. This creates a very high coil resistance and the battery pack voltages are correspondingly high, being in the hundreds to thousands of volts range.

The torque or turning power applied to the magnet in these motors is proportional to the magnet strength, the number of turns in the coil and the current flowing in the coil. In Joseph's motors, very large torques can be developed by very small currents. In one demonstration, a motor running on 3,000 volts at 0.8 milliamps has such power that it is not possible to stop the motor by holding its two-inch (50 mm) diameter shaft, though the current can be raised by trying to stop it, to 3 milliamps, or nine watts of power.

Joseph's motors are different in other ways. If fluorescent tubes are connected across the motor coil, they light up due to the coil's collapsing magnetic field each time the current direction is switched. These fluorescent tubes are used to protect the mechanical switch from arcing damage. The additional power produced in these tubes is at a very high frequency of 10 to 20 MHz. This radio-frequency current has been accurately measured and it exceeds the battery input current by a factor of five to ten times in the different motors. The measured current and voltage were in phase, indicating a real power output.

To understand the thinking behind these motors, we need to follow Joseph's experiments and the deductions which he made from those experimental results. Joseph considered, and thought carefully about statements made by the two scientific giants James Clerk Maxwell and Michael Faraday, and this led him to valuable

insights:

It appears that Maxwell and Faraday were the only people who considered that “lines” of magnetic force are actual physical entities and not just a method of representing notional forces and those “lines of force” are actually streams of **matter in motion**.

Maxwell says: “**In speaking of the Energy of the field, however, I wish to be understood literally**. All energy is the same as mechanical energy, whether it exists in the form of motion or in that of elasticity, or in any other form. **The energy in electromagnetic phenomena is mechanical energy**”.

Joseph then considered Michael Faraday’s Electrical Generator and the implications of the way in which it operated:

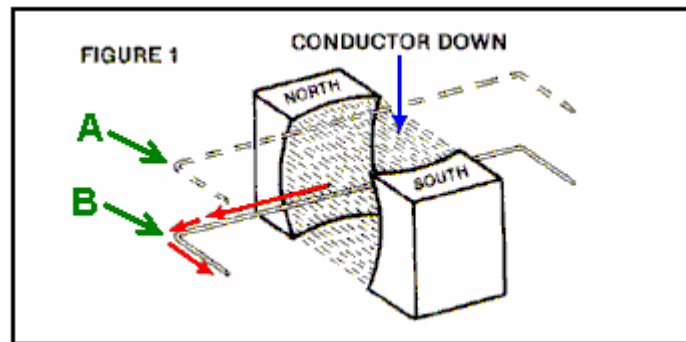

Here, a loop of wire is moved downwards from level “A” to level “B”. This movement causes an electrical current to flow leftwards along the wire as shown by the red arrows. Joseph’s question was “why does it go in that direction every time the wire is moved in that way?”

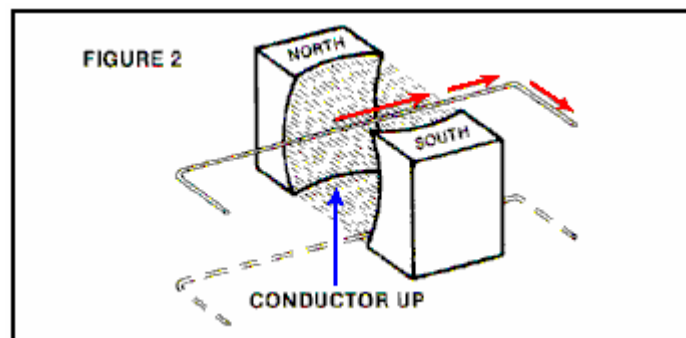

If the wire is moved upwards through the same magnetic field, then the current flowing in the wire moves in the opposite direction. Why? How does the current “know” which way to go?

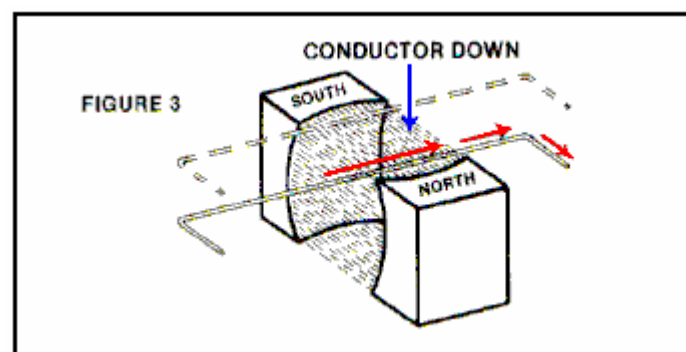

If you turn the magnetic field round by reversing the position of the magnetic fields and then move the wire loop in the same way as before, the current flows in the opposite direction. How does the current “know” which way to flow, or which way round the magnets are turned as it does not touch them?

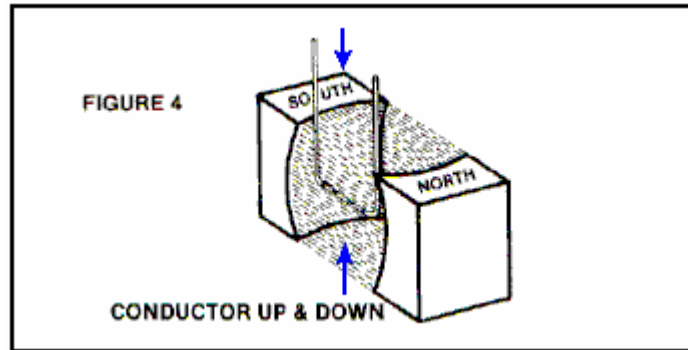

The next interesting point is that if the wire loop is moved up and down between the magnets, but turned to be parallel to the flux flowing between the poles, then no current flows in the wire, no matter how quickly the wire is moved up and down.

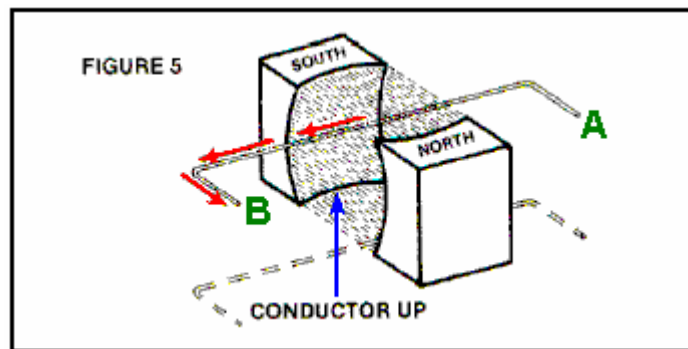

Another point is that if the wire loop is moved **slowly** up through the magnetic flux, the electric current which flows as a result of that slow movement, **moves at the speed of light**, flowing from "A" towards "B".

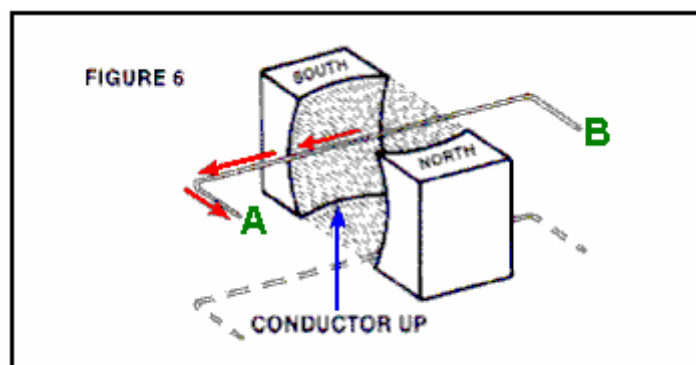

Now, if the wire loop is disconnected and turned over, the part which was at "A" now moved to "B", and the same movement of the wire carried out - the current flow is in exactly the same direction although its path along the wire is reversed (because the wire has been reversed). This shows that the direction of current flow is not affected by the wire itself.

According to conventional teachings, this electric current flow was not a result of the magnetic field as the magnetic lines of force were supposed to be imaginary, consisting of Potential Energy and **no** Kinetic Energy. It became clear to Joseph that this conventional teaching was wrong. Instead, it seemed clear that the magnetic field consists of particles which have mechanical characteristics, and those particles must be moving at the speed of light within the magnetic field.

A key question seemed to be: "how does the current 'know' which direction to flow?" as the direction was always consistent. After careful consideration, it occurred to Joseph that the answer was provided by the

actions of a gyroscope:

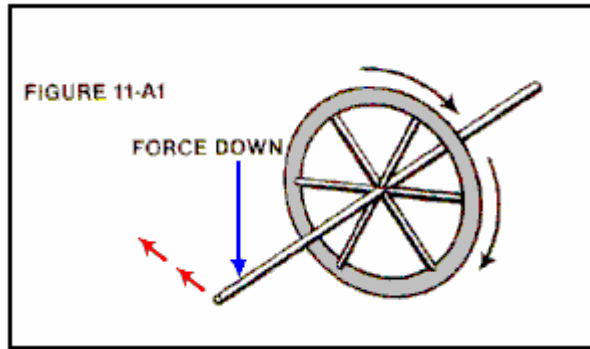

Here, if the axle of the spinning flywheel, or gyroscope, is pressed downwards it moves off in the direction shown by the red arrows. However, if the axle is pressed upwards:

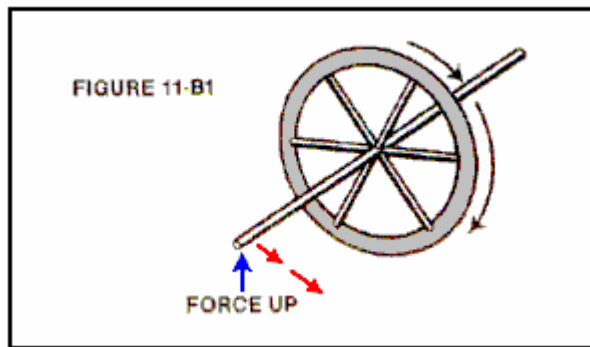

then the axle moves in the opposite direction as shown by the red arrows. This effect is, of course, reversed if the direction of rotation of the gyroscope is reversed (as it will be if viewed from the other side, in the same way as the current flow direction in the wire is reversed if the magnetic poles are swapped over).

Now, if the gyroscope axle is moved up and down equally on both sides, there is no resulting sideways force:

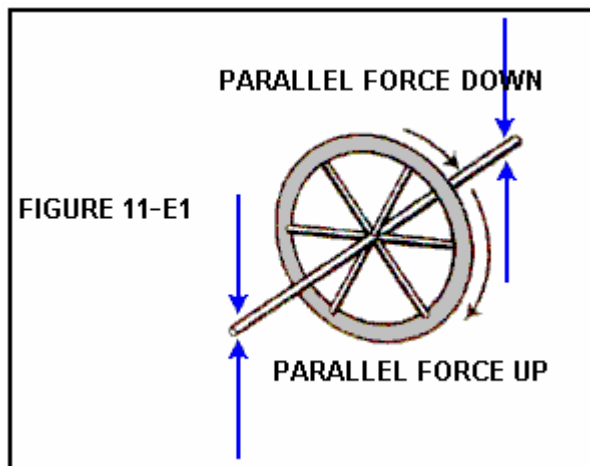

The action of the gyroscope axle matched the current flow in the wire in every respect, so it became clear to Joseph that the particles flowing between the poles of the magnet were spinning as well as moving at the speed of light. This gyroscopic mechanical motion of the particles accounts for all of the characteristics of the current flow in a wire which is being moved through a magnetic field. This is a major insight on the part of Joseph.

May I remark that these particles are not coming from the magnet itself, but are flowing in from the zero-point energy field, that flow being caused by the broken symmetry of the zero-point energy field generated by the dipole effect of the poles of the magnet. That is why energy can (appear to) be drawn from magnets for years on end.

Joseph then went on to consider the physical aspects of permanent magnets. There were two very significant facts which had to be considered. The first of these is that different materials have markedly different magnetic characteristics:

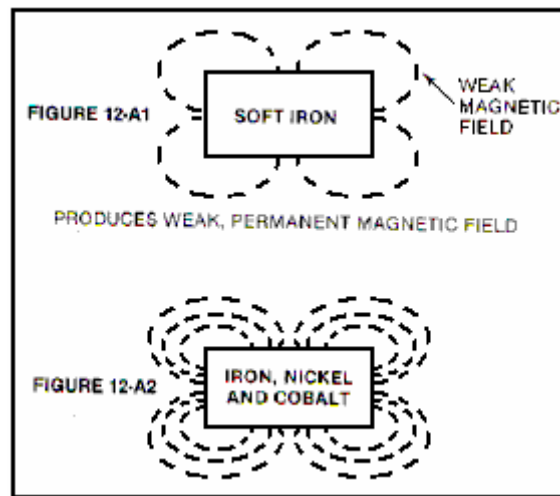

A bar of soft iron does become a permanent magnet when pulsed briefly with a strong magnetic field, but if exactly the same level of magnetic pulsing is applied to a similar bar of an alloy of iron, nickel and cobalt, a permanent magnet is also produced, but the magnetic field of the alloy is very much stronger than that of the soft iron bar. This shows that the molecular structure of the bar has a major effect on the resulting magnet.

In passing, please be aware that the more powerful magnets available nowadays are so strong that they can easily injure you. If you pick up a magnet and inadvertently get close to a second one, the loose magnet will jump some inches and try to connect to the one in your hand, crushing your fingers in the process and proving very hard indeed to shift in order to deal with the injury. I have also seen it alleged that US 'AlNiCo' (Aluminium / Nickel / Cobalt alloy) magnets are deliberately doped with K40 isotope which renders them useless fairly quickly. The source of this information is highly dubious, but the extra sales advantages to the magnet manufacturers would be significant. Also, the advantages for the people wanting to suppress the creation of free-energy magnet motors would be major as many talented US inventors are likely to think that their successful magnet motors were failures because the magnets appeared to be "drained of power" by being used in their design, when in fact, the design is perfectly good. So I will leave you to make up your own mind about the matter and remark that Bill Muller found that his powerful Chinese-manufactured magnets were in perfect condition after eleven years of use.

Another point which Joseph considered was the fact that when successive magnetic pulses are applied to a ferromagnetic metal bar, the resulting magnetic field strength reaches a definite maximum value, and further pulsing has no further beneficial effect:

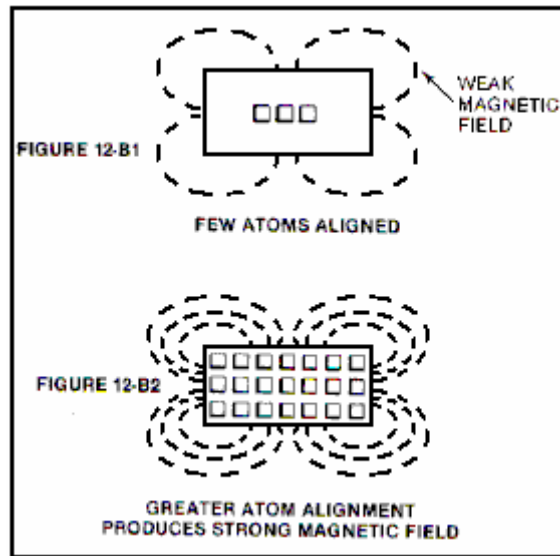

This is considered to be the magnetic pulse aligning atoms in the metal. Eventually, all of the atoms are aligned and so no further effect can be produced by further pulsing. This alignment can be destroyed if the metal bar is heated to a sufficiently high temperature, forcing the atoms into such an energetic state that the alignment is lost.

It should perhaps, be stressed here, that the magnet itself does not have any power, in spite of seeming to have. Tom Bearden explains this clearly by pointing out that what happens is that the opposite poles of the magnet created a “dipole” which unbalances the random ‘quantum foam’ nature of the local environment (the zero-point energy field) and that causes continuous energy flows from the environment. The “magnet” power is coming from the environment and not from the magnet itself.

If you find this hard to believe and think that you are just getting back the electromagnetic energy which you pumped into the metal when creating the magnet in the first place, then apply simple arithmetic. Assume that you get back exactly 100% of the original power and calculate how long that amount of power would allow the magnet support its own weight against gravity, when attached to a vertical metal surface. Then ask yourself how come the magnet can do it for years and years on end. Point proved conclusively?

Joseph concluded that the attraction of “unlike” magnetic poles and the repulsion of “like” poles is caused by the gyroscopic spin direction of the actual physical streams of the “lines of force”, which he has shown that both of the scientific giants, Maxwell and Faraday were convinced were actual physical entities. The intuitive genius Nikola Tesla described the zero-point energy field as having the physical characteristics of a gas, capable of having motion, exerting pressure, and yet having particle size so small that it can flow through any physical material. Joseph has concluded that this field flow has a specific spin direction as it flows, certainly for flows caused by the magnetic dipole of a magnet. It should be remembered that the scientific teaching of present day educational institutions is at least fifty years out of date. We have the most unusual situation where the scientific literature of a hundred years ago is actually of better quality than that of today which does not describe the actual world at all well. Currently, misconception is alive and very well.

For example, Maxwell produced equations describing how the world works. Admittedly, these equations are very difficult for people to understand. H. A. Lorentz simplified these equations and his results are mistakenly described as Maxwell’s which they most certainly are not. Tom Beardon illustrates it this way; consider a sailing boat being driven along by the force of the wind against the sails:



Maxwell says that there is a vast swathe of wind blowing across the ocean, capable of powering a long row of a thousand sailing boats side by side. This is the actual physical case. Lorentz has 'simplified' things by saying "we will consider one boat and only one boat. As the rest of the wind does not touch any part of the boat we can ignore it". While that is true for that one boat, what science teaching now says is that the wind can **only** power a single boat. This is not the actual case, as the environmental wind is **not** limited to powering just one boat (sailing regattas would not be much fun if that were the case!). This, of course, is just an illustration. Maxwell's equations cover energy and power for the whole universe, and deal with all cases. Lorentz has taken a sub-set of the conditions described by Maxwell's equations, just the group which apply to "closed systems" – just one boat on the ocean. Science has latched on to this and now confidently states that everything is a "closed" system, when in fact, as the zero-point energy field flows through everything, everywhere at all times, and is capable of supplying unlimited additional energy anywhere at any time, there is probably not a single instance of a "closed" system anywhere in the universe.

Joseph Newman, and all other serious inventors, have to fight against this "conventional" science teaching, which is now so entrenched that it has become the equivalent of religious dogma, and 'scientists' are unwilling to consider valid observations which do not fit in with the very limited Lorentz concept of the environment. They say "perpetual motion is impossible" which means that Newton was wrong when he said that a moving body will keep on moving indefinitely unless some force acts on it to stop it. Presumably, then, the Earth can't keep on orbiting the Sun (gosh, I hope it doesn't stop today as that would be very awkward). Come on – get real !!

You can see then, that when Joseph performs tests and then bases his conclusions on the results of those tests, that he is applying the true scientific method, and people who say that his verified results are impossible because Lorentz says so, are not being scientifically honest. No honest person can ignore genuine scientific observations.

Joseph's deduction that magnetic lines of force are formed of actual physical particles spinning in gyroscopic motion as they move along their magnetic path at the speed of light, was not something which was obvious to scientists, in spite of the fact that both Maxwell and Faraday had both explicitly described these lines of force as being 'kinetic magnetic energy':

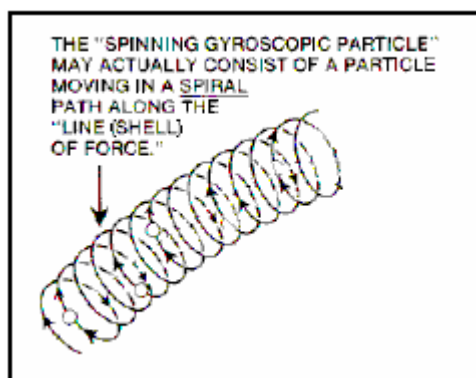

As a wire passes in front of and across the end of a bar magnet, the current flows in one direction, pauses, and then flows in the opposite direction. This occurs due to the gyroscopic flow direction of the particles. For instance, on one side of the South end of the magnet, the lines of force spin "up" while on the other side

of that same South end, they spin “down”. A spinning gyroscope will move at right angles to the force acting on it, so as the gyroscopically spinning particles encounter the particles of the wire, they move “up” or “down” the wire at right angles to the direction in which they first encounter the wire. Please note that it is the gyroscopic spin direction of the particles which determines magnetic ‘attraction’ or ‘repulsion’ and not the direction of flow of those particles along their line of force:

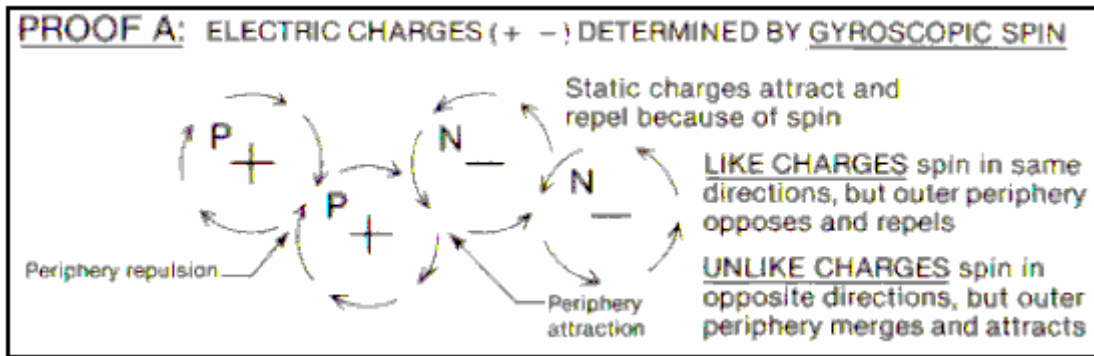

It should also be realised that although we draw ‘lines’ of force around a magnetic device, the reality is that these are really shells of force and the magnetic flow is really like water flowing in a river. While we may draw arrows to indicate direction and strength of currents in a diagram of the river, the reality is, of course, that there is water flowing at all points in the river and not just along the lines which we decide to draw. The same applies to the magnetic flow around a magnet, it exists like a solid mass flowing through and around the magnet. You don’t see it or feel it because the particles are so small.

Now to the details of how to construct a device to take advantage of this magnetic movement and output more power than is required to make it operate. Let me remind you again that we are talking here of a Coefficient of Performance (COP) which is greater than 1 in a system which has an overall power efficiency of less than 100%. This is, of course, due to the additional energy flowing in from the zero-point energy field. Joseph visualises the apparent energy gain as being conversion of a small amount of matter into its energy form ($E = mC^2$), and while this is probably correct, it will be particles of the zero-point energy field which are being converted into their energy form and not particles from the metal of the magnet. It must be remembered that the particles of the zero-point energy field keep swapping over from energy to physical form all the time anyway. Energy is never “used up” but merely converted from one form to another and the zero-point energy field contains such a staggering amount of energy that all of the visible matter in the whole of the universe could be created from the energy in a single cc of the zero-point energy field. So, if a few sub-sub-sub-microscopic particles of the zero-point energy field switch into their energy form to produce what looks like excess power to us, that is an item so trivial to the field that it is not even worth mentioning – less than the effect of taking one grain of sand off a beach one hundred miles long. The conventional conception of the way things are is so far away from reality that it is ridiculous, (and that is even without saying anything about the effect that the time axis dimension has on the energy balance and flow of energy).

But back to Joseph’s design. Firstly, he points out that it is generally agreed (courtesy of Gustav Kirchhoff) that in the situation shown here:

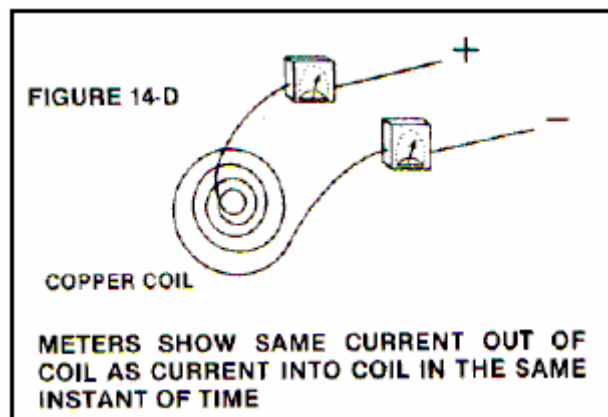

In any given instant of time, the amount of current flowing into the system ("X") is exactly matched by the amount of current flowing out of the system ("X"). **But**, if measuring equipment is attached across the coil at the moment of switch-off, an additional amount of current ("X") flows out of the coil. This is generally agreed, and it suggests that a quantity of current "X" flows into the coil and yet a quantity of "2X" flows out of it (COP=2).

Joseph examines this situation in practical detail as follows:

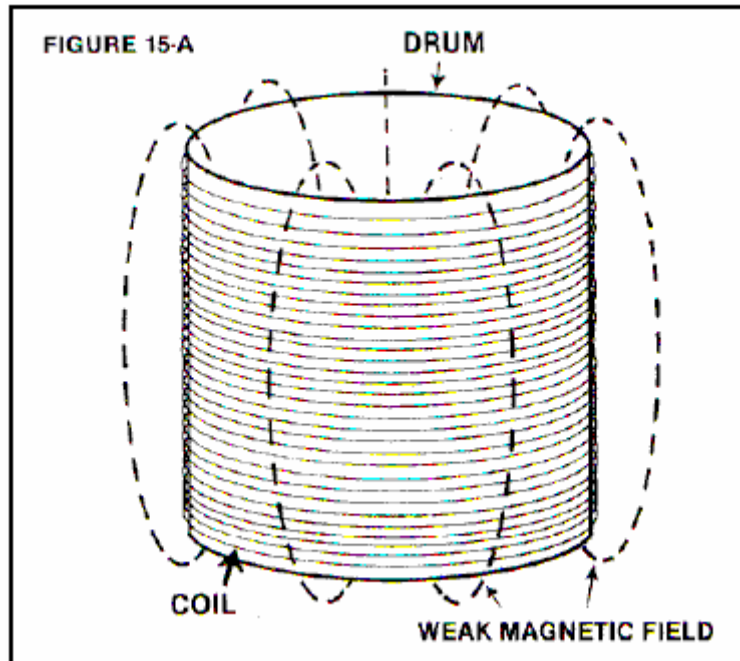

Consider an air-cored coil with an interior diameter of 10 feet, a height of 8.32 feet and would with 1,000 feet of 40-gauge copper wire. That length of wire has a resistance of 1,049 ohms and weighs 0.02993 pounds. If 100 volts DC is connected across it, then a current of about 95 milliamps will flow, which is a power input of 9.5 watts. With just 31.8 turns, it will produce a weak magnetic field of 0,012 Gauss, with a mere 0.000014 Joules of energy stored in it. With a tiny inductance of just 0.003 Henries, if the current is stopped and the ends of the coil shorted together, only an insignificant current would flow.

Now, repeat the experiment, but this time, use 5-gauge copper wire. As it has a resistance of 0.3133 ohms per 1,000 foot length. To equal the same resistance and match the previous current flow, a massive length of 3,348,000 feet needs to be used. This length of wire will weigh 335,469.6 pounds which is 16.77 tons. The 10-foot interior diameter coil, 8.32 feet tall, wound with this wire will have about 90,000 turns. If 100 volts DC is now connected across the coil, the same 95 milliamp current will flow with an input power of 9.5 watts, the same as before. But due to the massively larger coil, it has a magnetic field of 23.7 Gauss, which is 1,905 times larger than the previous coil, and with 116 Joules of energy stored in the magnetic field. This is a phenomenal 8,000,000 times more energy than in the 40-gauge coil of the previous example. A phenomenally larger current flow would now occur if the current input was stopped and the coil shorted out, as that would generate an inductance of 25,700 Henries which is more than eight million times the inductance of the previous coil:

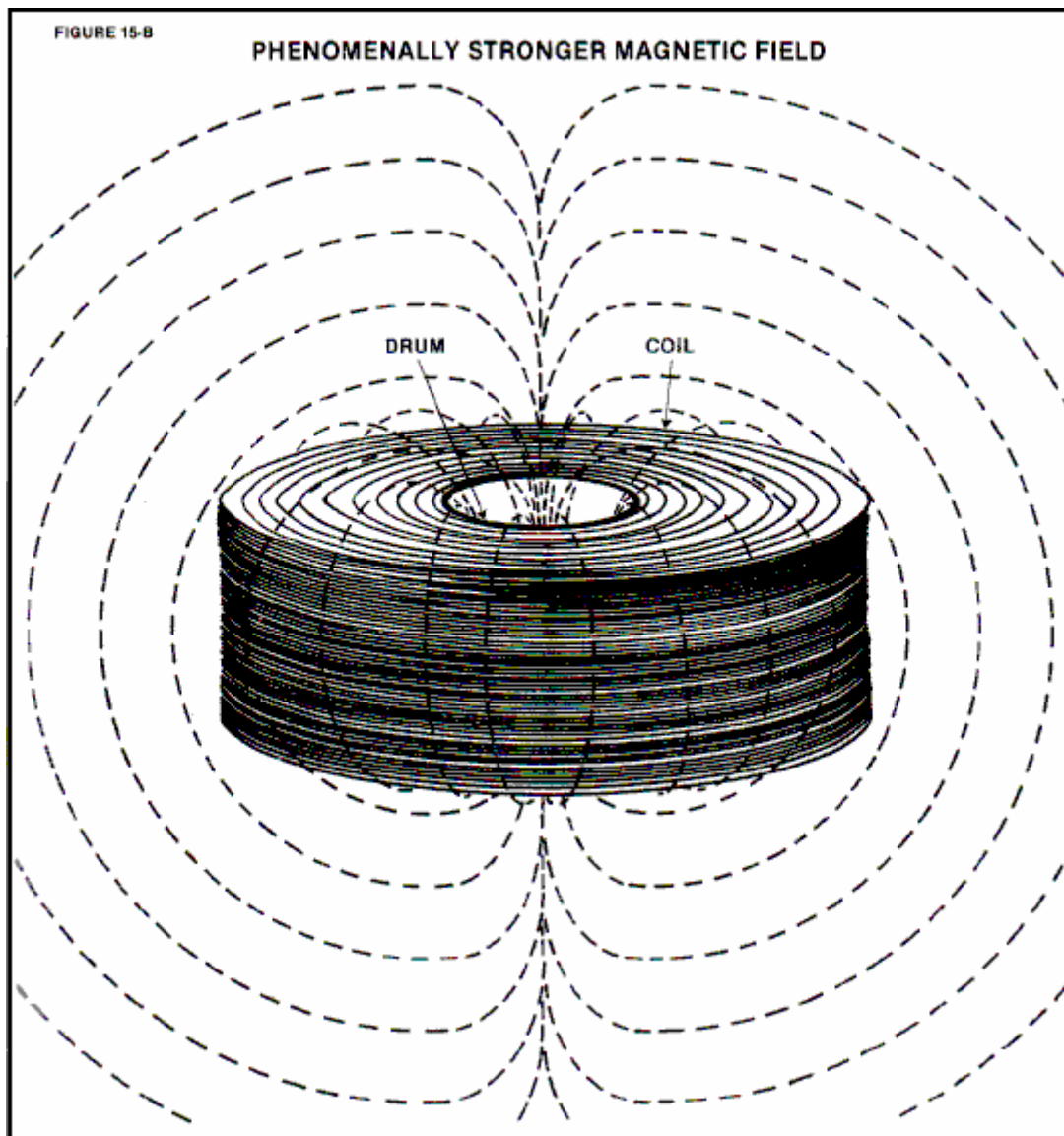

Joseph then built a smaller version of his design, as shown here:



this prototype used 5-gauge insulated copper wire weighing 4,200 pounds and 300 pounds of 30-gauge copper wire wound over the 5-gauge winding, and a massive 4-foot long, 20-inch diameter permanent

magnet of some 600 pounds in weight. The coil was wound with an inner diameter of 4-feet and a height of about 3-feet, wound on a fibreglass tube. The overall weight was about 5,000 pounds.

Everybody who was it was asked: "Based on your expertise, how much power would be necessary to simply operate this device mechanically?". Answers ranged from 200 watts to 1,000 watts. On learning that it had an air-cored coil, other skilled individuals stated that in their expert opinion, the unit would be highly inefficient since it contained no iron core. However, from the design information already presented here, it can be shown that the actual necessary power input is less than 1.5 watts providing a power output far in excess of 100%.

Dr. Roger Hastings, Principle Physicist at Sperry Univac Corporation and former Associate Professor of Physics at North Dakota State University, tested this prototype and showed that it had an 800% efficiency – that is a Coefficient of Performance of 8.0 which is impressive. In addition, Dr Hastings estimated that with a 1.5 watt power input, the back emf exceeded 80,000 watts. In operation, the 600-pound, hand-made magnet rotates at just 200 rpm.

Joseph's patent which is in the Appendix, indicates four different ways of implementing his design principles. It is very clear that Joseph has proved his point by producing and constructing a device which Oliver Lorentz considered to be impossible, thanks to his throwing out the free-energy sections of Maxwell's equations. Joseph Newman has clearly earned our respect.

You can see J L Naudin's builds and tests of small models at <http://jnaudin.free.fr/html/qm11bp.htm>.

Daniel Cook's Motionless Generator.

In 1871, Daniel Cook obtained US Patent 119,825 for "An Improvement In Induction Coils". It is by no means obvious how the device described could possibly operate, and it has been suggested that the patent information is incomplete, having been edited at a later date. But as I have no direct evidence that it does not, or cannot, operate, it is shown here. Interestingly, the highly-respected Dr Harold Aspden considers this a very serious piece of equipment, operating as paired cross-linked capacitors, and his opinion carries very considerable weight.

It is a very simple device which could be interesting to test, especially as it does not involve any electronics or complicated construction. The patent can be summarised as follows:

My invention relates to the combination of two or more, simple or compound, helical coils with iron cores or magnets, in such a manner as to produce a constant electric current without the aid of a battery.

Fig.1 represents the different parts of a compound helical coil and iron core.

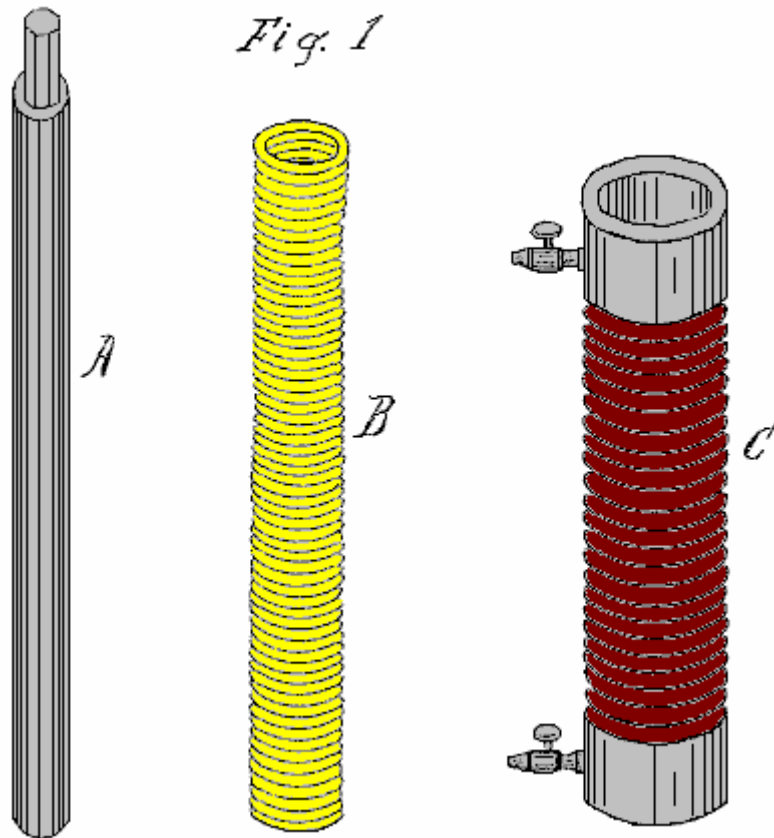
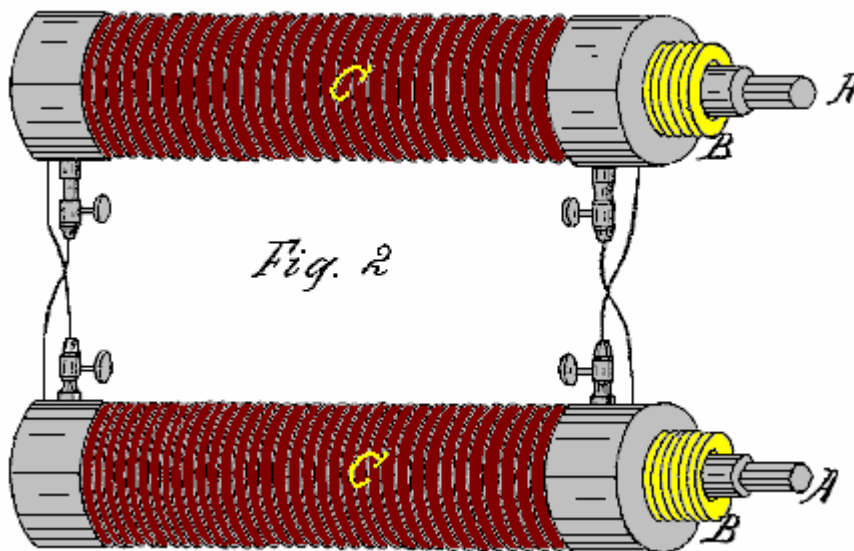

Fig.2 is a perspective view of my invention.



In carrying out my invention, I do not confine myself to any particular mode of coil construction or to any particular size of wire, observing only that the quantity of wire in the various coils must be sufficient to produce the required result; also, the material used to insulate the wires must be suitable for producing the required result. However, I generally prefer to use the same size of wire in the construction of both simple and compound coils.

When constructing simple coils, to produce the required voltage and current, it is desirable to use a long iron core as shown as **A** in **Fig.1**. This iron core may be two, three or even six feet in length, and two, three or more inches in diameter. The coil should be wound from good quality copper wire, insulated with silk or

shellac. The iron core **A** may be a solid bar or a bundle of separate iron wires, the latter giving better results and providing more current for any given wire diameter. While the wire may be fine or coarse, I prefer to use No. 16 or even heavier wire, as the power output is in proportion to the length and diameter of the wire.

When using compound coils, it is preferable in some cases to use a small wire, say, No. 30 or even less, for the primary coil, and No. 16 or even larger for the secondary coil. With this combination, the initial secondary current of the primary coil being very small in comparison to the terminal secondary current of the secondary coil, offers little resistance to the terminal secondary, hence a quicker action is obtained. Alternatively, the primary coil may be of uninsulated wire coiled into a solid helix, being insulated only between the coils, in which case there is little or no opposing initial secondary current.

Helically wound coils alone with large quantities of wire will produce similar results. A ribbon spiral may be substituted for the secondary coil **C**, say, of three, six, twelve or twenty-four inches in width and of any convenient length, but always of sufficient length to raise its output current to the level necessary to sustain itself through its action on the primary coil **B**. In the use of compound coils, it is important that the secondary coil should be wound in the same direction as the primary coil, and the primary and secondary coils be cross-connected as shown in **Fig.2**. The action will then be as follows:

The secondary current of the secondary coil **C**, will circulate through the opposite primary coil **B**, while at the same instant, a secondary current from the primary coil **B** will be generated and circulate through the opposite secondary coil **C**, both currents flowing in the same direction in the opposite coils **B** and **C**, producing a combined magnetic action on the iron core **A** in the centre. The opposing initial secondary currents of the two coils **B** and **C** being overpowered, do not show in the main circuit **D** of the device, there being eight distinct currents developed in the action of one entire circuit of the two pairs of coils, two terminal and two initial secondary currents to each pair of coils, the four initial secondaries constantly opposing the circulation of the four terminal secondary currents, but the initial secondaries being of much lower voltage and current than those of the terminal secondary, are overcome, leaving a sufficient surplus terminal power to overcome the resistance of the primary wire and charge the bar **A** to the degree needed to reproduce itself in the opposite secondary coil. By this means, a constant current is kept flowing in all of the coils.

These coils may be constructed using 500 feet to 1,000 feet or more for each of the primary and secondary coils. The longer, and better insulated the wire, the greater is the power obtained from the device. The larger the wire diameter, the greater the current obtained.

If only single coils are to be used, it is preferable to have a wire length of 1,000 feet or more in each coil. The action is the same as with the compound coils, but only four currents are produced: two initial and two terminal currents, the latter flowing constantly in the same direction - in effect, there being only one current in the same direction.

The action in the coils may be started by using a permanent magnet, an electromagnet or by pulsing an extra coil wound around the outside of one of the coils of the device. If the load circuit is broken for any reason, the current stops immediately. It is then necessary to perform the start-up procedure again to get the device restarted. This can be overcome by permanently connecting a resistor across the terminal of the load so that if the load circuit is broken, the device can continue under very much reduced current until the load is restored. By this means, the device becomes the direct equivalent of a battery.

A rheostat **D** may be introduced into the main circuit to limit the current and prevent the overheating of the coils through the drawing of excessive amounts of current. The iron cores may also be used for producing electromagnetic motion when the device is operating.

Note: Interesting replication attempts are shown at <http://www.overunity.com/index.php/topic,2630.0.html>.

Michael Eskeli's "No Work" Generator.

One of the greatest expenses for many families is the cost of heating or cooling a home. Any device which can help with this task is definitely welcome. Michael Eskeli has produced several most interesting designs which may have been overlooked due to lack of emphasis of what they do.

Normally, a central heating system uses an expensive method of heating a liquid, typically oil, which is then pumped through radiators around the building by a low energy pump. The vast majority of the cost is in heating, typically, a furnace and very little is spent on moving the heated liquid through the radiators. In this

design from Michael, the cost of the heating is zero, and all that is left is a low-power (quarter to half horsepower) input, needed for spinning a rotor against the friction of its bearings and stuffing box.

As this seems impossible, a little very technical explanation is given here. This information has come from the web site of Scott Robertson at <http://www.aircaraccess.com/> with his kind permission. In broad outline, the device comprises of a disc-shaped housing with a closely-fitting rotor spinning inside it. A gas under pressure and a liquid under pressure are both fed into the device and they intermingle in a pulsating sequence which alternately compresses and releases the pressure on both fluids. This heats both fluids very effectively, and most interestingly, without the use of any user-supplied heating power and without the use of any heating fuel. This next paragraph is for Engineers, so if you don't understand it, then just ignore it, as the important thing is to understand what the device does, rather than exactly how it does it.

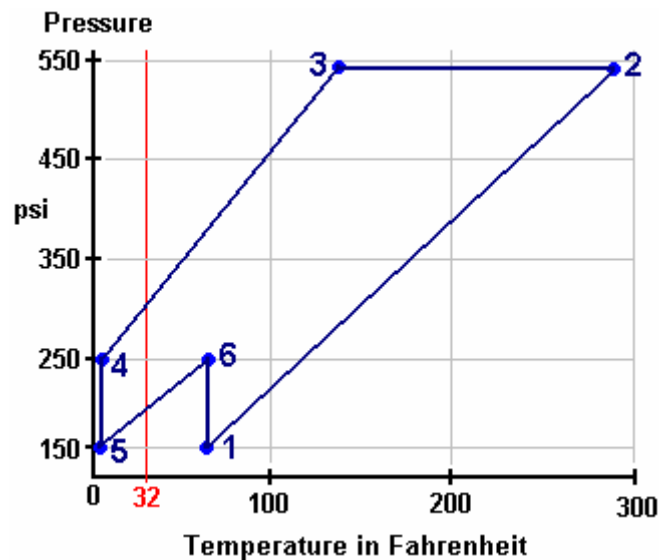

The Heat-Pump Work Cycle: The example diagram above shows the sequence of events caused by the rotation of the disc inside the device housing. This “**Pressure / Enthalpy**” or “**Pressure / Internal-Energy**” diagram shows the pressures and temperatures during a single pressure cycle of the device. Using nitrogen as the gas, the cycle starts at point “1” which has a pressure of 150 psi and a temperature of sixty degrees F. A pressure wave now hits the mix of nitrogen and the liquid. This pressure wave moves us to point “2” where the pressure has been boosted to 540 psi which raises the temperature to 280 degrees F.

Moving to point “3” is where the wanted heat is passed throughout the gas and the liquid (performing the heating task which is the whole object of the exercise), even though the pressure is maintained, so at point “3” there is a pressure of 540 psi and a temperature of 138 degrees F. Next, comes a major drop in pressure, taking us to point “4” pulling the temperature down to below freezing: 250 psi at just 4 degrees F. At point “5” the pressure is dropped further to 150 psi, still at 4 degrees F. Point “6” takes us to 250 psi at 60 degrees F from where the cycle takes us back to point “1”, and the sequence starts all over again.

The compression takes place on leg 1 to 2 and leg 5 to 6. The actual amounts are 53.2 and 13.5 respectively, giving a **Compression Total** of **66.7** B/lb.

The expansion takes place on leg 3 to 4, leg 4 to 5, and leg 6 to 1. The actual amounts are 31.6, 16.6 and 18.7 respectively, giving an **Expansion Total** of **67.0** B/lb.

As these two are virtually identical, the overall result of a complete cycle is effectively **work-free**.

This work cycle can be readily performed by the **Centrifuge-Type Heat Pump**. This is a unit which has only one moving part, the rotor, the working fluid, such as nitrogen, is sealed in with the rotor and circulates in passages in the rotor. The circulation of the working fluid inside the rotor is accomplished by density control alone, in accordance with the work-cycle shown above, and **there is no work input to the working fluid from the rotor shaft**. Thus the work input for the heat transfer is nil, and a work-free heat pump results.

In the diagram shown below, an axial cross-section and an end view with sections removed, shows a typical heat pump rotor suitable for use with the work-cycle discussed above.

In the diagram, **10** is the heated-fluid heat exchanger, **11** is the heat-supply heat exchanger in two parts, and **12** are the vanes in passages which return the working fluid from the periphery to the centre of the disc. The work cycle process is of the non-flow type for the working fluid in this rotor, and this provides higher performance than that in the example shown above.

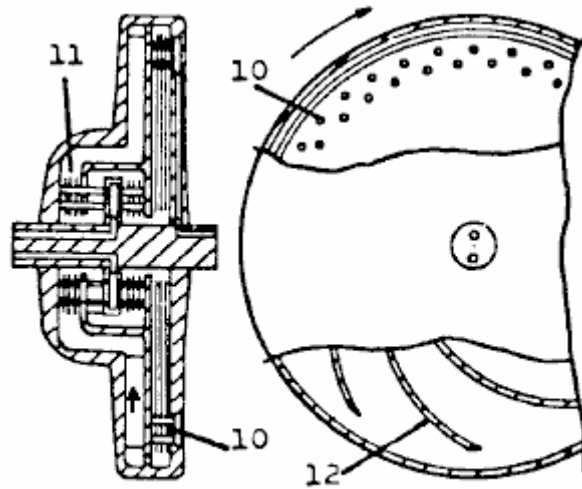

Centrifuge-type Heat Pump

The fluid to be heated is usually a liquid, such as water, which enters and leaves the rotor via the rotor shaft. Similarly, the heat-supply fluid circulating through heat exchanger **11**, is a liquid which enters and leaves via rotor shaft passages.

The work-free heat pump obviously has many uses. One such use is in heating all types of buildings and homes, resulting in cost-free heating, since no fuel is needed, and the power usage is nearly nil. In the heat pump shown above, power is needed to drive the rotor against friction which may require a quarter to half horsepower motor.

Another use is in power generation, resulting in cost-free power since the unit uses no fuel, the energy source being either ambient air, or water from some natural source. (Attached turbine generates the power; part of this is used to overcome the heat pump friction loss and the remainder is available for generation of electricity). Further uses are in portable power and transportation vehicles, etc.

The apparatus and methods and work cycles are patented. For basic heat pump, see US Patent 3,926,010 and Canadian Patent 984,827.

Michael Eskeli.

Here is one of Michael's many patents:

US Patent 3,650,636

21st March 1972

Inventor: Michael Eskeli

ROTARY GAS COMPRESSOR

ABSTRACT

Method and apparatus for a compressor for compressing air, gases and vapours isothermally using a liquid stream to compress the gas; the liquid issuing from an impeller intermittently, with the gas being entrained between these liquid pulses and compressed by the liquid; the liquid having high kinetic energy when leaving the impeller and in slowing the kinetic energy is converted to pressure for both the liquid and entrained gas.

Also, this compressor may be used advantageously to compress vapours, wherein the liquid is the same fluid as the gas, in which case condensation of the gas to the liquid occurs, and work of compression is reduced.

US Patent References:

1009908		November 1911	Lafore
1115942		November 1914	Kieser
1192855		August 1916	Buss
1488388	Centrifugal pump	March 1924	Hariveau
1521270	Vacuum pump	December 1924	Bogdanoff
2007138	Boiler feed pump apparatus	July 1935	Becker
3001691	Jet operated device for circulating or compressing a fluid	September 1961	Salmon et al.
3081932	Gas or fluid compressor	March 1963	DeLancey

BACKGROUND OF THE INVENTION

This invention relates generally to devices for compressing gases, air and vapours, in which a liquid is in intimate contact with the gas or vapour to be compressed.

DESCRIPTION OF PRIOR ART

There are numerous devices and machines available for compressing a gas or a vapour. In some of these machines a liquid is rotated inside an eccentric casing, so that the machine rotor will cause the liquid to pulsate and the space between the rotor blades is increased or decreased, and this variation compresses the gas. These machines are called liquid piston type machines. Another device is the jet ejector compressor, where a stream of liquid or gas is used to entrain the gas or vapour to be compressed, and the kinetic energy of the stream is converted in a diverging nozzle to a pressure.

The main disadvantage of the liquid piston type machine is its poor efficiency, since the liquid is rotated in the machine and requires relatively large power input for compressing the gas. In the ejector compressor, the velocity of the liquid stream is limited and it entrains poorly of any gas; therefore the efficiency of the device is very poor. The available kinetic energy in the liquid stream is high, but due to poor entrainment of the gas by the liquid, results for the device are poor.

BRIEF DESCRIPTION OF THE DRAWINGS

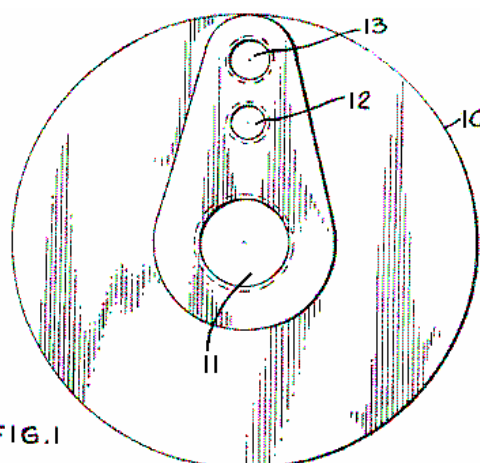

Fig.1 is an end view of the compressor casing, showing the exterior.

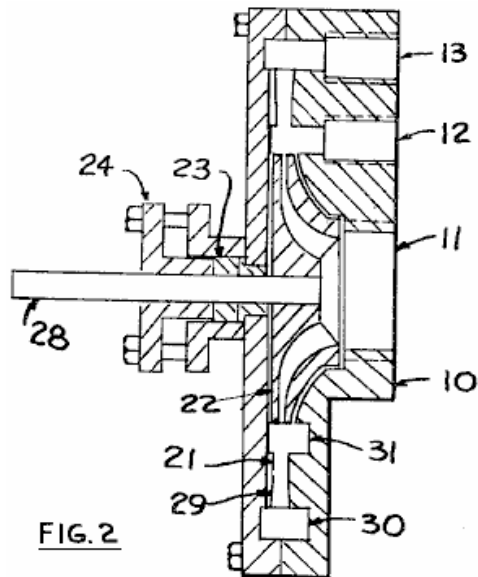

Fig.2 is a side view and a section of the casing and the impeller of the compressor.

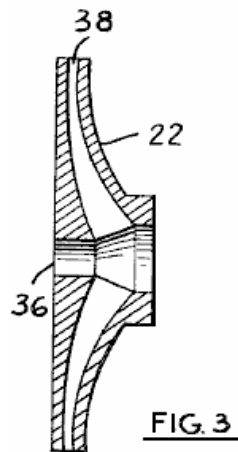

Fig.3 is a side view and a section of the impeller, and

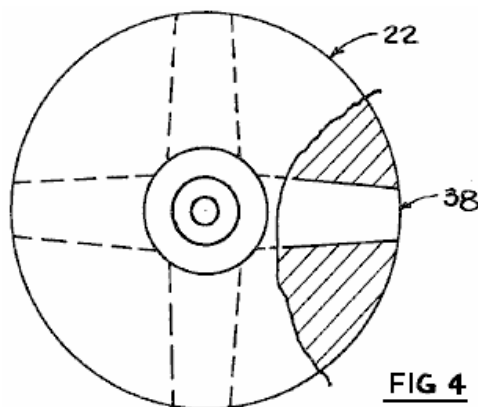

Fig.4 is an end view of the impeller, showing the fluid passages.

DESCRIPTION OF PREFERRED EMBODIMENTS

It is an object of this invention to provide a method and a device for compressing gases or vapours essentially isothermally in which the kinetic energy contained by a liquid stream is used to compress said gas to a higher pressure where the liquid in slowing in speed will increase its pressure and increase the

pressure of the gas being entrained in it. Also, it is an object of this invention to provide a method and a device in which the gas may be partially or fully be condensed in the liquid stream thereby lowering the work of compression; this occurring when the gas or vapour being compressed is the same fluid as the liquid; that is, the gas being compressed is the vapour phase of the fluid, and the liquid being used for as the motive fluid is the liquid phase of the fluid.

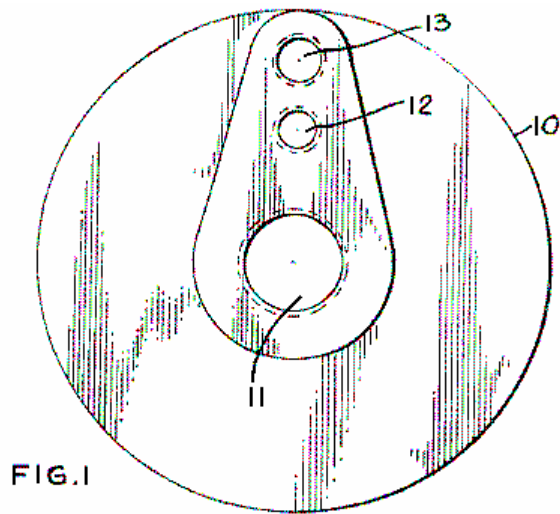

FIG. 1

Referring to **Fig.1**, there is shown an end view of the compressor, where **10** is the compressor casing, **11** is the liquid inlet, **12** is the gas or vapour inlet, and **13** is the outlet.

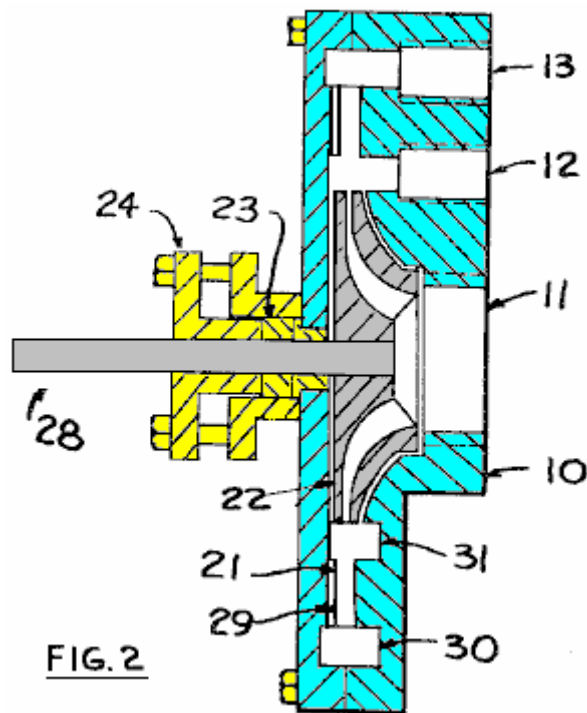
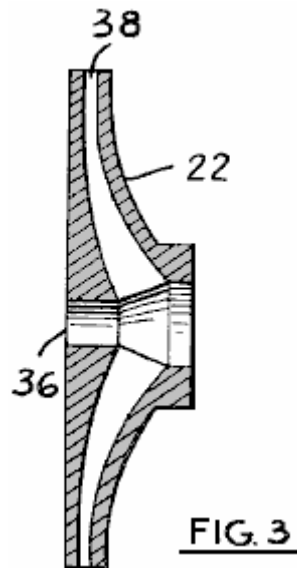
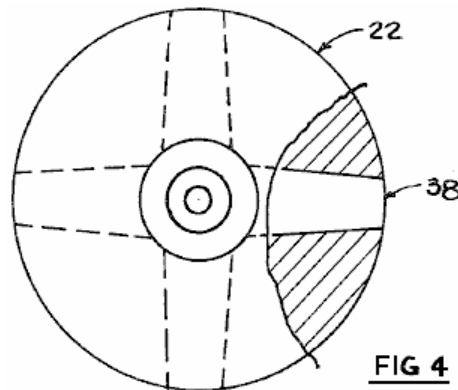

FIG. 2

In **Fig.2**, a side view of the compressor is shown. The impeller **22** is rotated by shaft **28**, supported by bearings and sealed by packing **23** and stuffing box **24**. Alternately a mechanical seal could be used. The liquid that is used as the motive fluid enters through opening **11**, passes through the impeller **22** and leaves the impeller at a high velocity and entering the throat section **21** and from there the diffuser section **29** in the casing **10**. After leaving the diffuser at a higher pressure, and at a lower velocity, the gas and liquid mixture is collected in annular space **30**, and from there passes out through opening **13**. The liquid entrains gas from annular space **31**, and the gas enters the annular space from outside through opening **12**.



In **Fig.3**, the impeller **22** is shown in more detail, where **38** is the fluid passage, and **36** is the opening for the drive shaft.



In **Fig.4**, the impeller is shown, with **22** being the impeller and **38** being the fluid passage.

In operation, the compressor functions in a manner similar to a jet ejector compressor. A motive fluid is accelerated in a passage in the impeller to a high velocity; this corresponds to the motive fluid nozzle in a jet ejector. However, the fluid stream issuing from the impeller, when it rotates, is not continuous as seen by the compressor casing, since in this particular instance, the impeller has four fluid passages, with solid material between them. Therefore, the flow from impeller, as seen by the compressor casing, is pulsating, with empty spaces between the high speed liquid; these empty spaces being filled by the gas from the annular spaces, item **31**, **Fig.2**, and the gas being rapidly moved with the liquid to the outer annular space **30**, and from there to discharge. This pulsating action improves the entrainment of the gas by the liquid, and more fully utilises the kinetic energy available in the liquid stream.

The sizing of the fluid passages and the calculations related to them, are fully described in thermodynamics literature for jet ejectors and for steam injectors. The space of the passage **38** in **Fig.3**, would be either converging for liquids that do not vaporise when leaving the passage; or the passage could be diverging at its outlet for fluids which will vaporise either partially or fully when leaving the passage. Of the non-vaporising liquids, water would be an example, and of the partially vaporising types, butane would be an example, both at atmospheric temperatures, and at low pressures. As illustrated in **Figs. 2-4**, passageways **38** comprise a converging section nearest the centre of the impeller but are at least non-converging at the discharge section. Preferably, the at least non-converging section is a diverging section for better taking advantage of the energy available in the motive fluid to achieve higher exit velocities.

The fluid passages shown in **Fig.4**, item **38**, can be radial as illustrated, or be forward or backward curved, depending on the fluid used. Also, the throat section **21**, of **Fig.2**, may have vanes of proper shape to prevent circular motion of the fluid after it leaves the impeller. Vanes of this type are commonly used in

turbines and pumps and so are not described here. There are four fluid passages shown in **Fig.4**, but this number will be determined when calculations are made for the size of the passages, and the frequency of pulses of liquid required to maintain suitable pressure and volume relationships inside the compressor; also, the rotational speed of the impeller would enter into these calculations.

Normally, the amount of liquid is large when compared to the amount of gas or vapour. Therefore, when compressing a gas, the heat of compression from the gas is transferred to the liquid, resulting in a temperature increase of the liquid, as well as of the gas. This temperature increase is much less than it would be for the gas alone, resulting in nearly isothermal compression, and therefore reduced work of compression, as compared to isentropic compression which is often used in rotary compressors. Also, if a liquid that will expand in the impeller is used, with an expanding fluid passage, the temperature of the motive fluid is lowered, and the fluid velocity greatly increased, resulting in much better efficiency for the compressor; this is similar to the function of converging-diverging diverging nozzles in jet ejectors.

The operation of the compressor may be inferred from the above descriptive matter. A liquid source is connected to the impeller inlet **Fig.1, 11** and a gas or vapour source is connected to the gas inlet **Fig.1, 12**. Discharge from the compressor is from **Fig.1, 13**. A suitable power source, such as an electric motor, is connected to shaft **Fig.2, 28**, causing the shaft to rotate. The liquid is accelerated by the action of the impeller, and as it passes through the annular space **Fig.2, 31** in a pulsating flow, it entrains the gas and carries it to annular space **30**, from where it discharges.

Materials of construction for the compressor would be similar to those used to make pumps for pumping liquids. Cast iron, steel, bronze, brass, stainless steel and various plastics could be used.

CLAIMS

What is claimed new is as follows

1. A machine for compressing gaseous fluid and having the major components of:
2. The machine of claim 1 wherein said at least non-converging section is diverging.

The Work of Karl Schappeller.

There have been a number of quite outstanding men who have had great insight as to how the universe is and how it operates. One of these is Karl Schappeller who is virtually unknown. One of the reasons for this is the fact that publicising his work has been strongly opposed by people who do not want his understanding to become widely known. One device produced by Karl in order to prove that his understanding of things was correct, produced substantial amounts of excess energy, and while I do not know of anybody who has replicated his device, I am including here, a short presentation on the subject, written by Henry Stevens and the book by Cyril Davson can be downloaded from <http://www.free-energy-info.tuks.nl/Davson.pdf> and read in full.

In the presentation by Henry Stevens, he mentions UFOs or flying discs. There has been a propaganda campaign waged against the general public for more than fifty years now, with the objective of persuading people that "UFOs" are not real, and if they were, then they would be the vehicles of "little green men". This campaign has been remarkably effective and members of the public in general will immediately dismiss flying discs as being "impossible" and not something which any sane person would consider for a moment. This attitude is based on an almost total lack of knowledge of the facts. There are at this time, large numbers of flying discs, built by humans and capable of spectacular flight abilities. There are two varieties: those which need the atmosphere to operate and those which don't.

If you feel that this is a "load of rubbish" then take a look at the following US patents:

US 2,718,364, Ernest Crabtree



US 2,772,057, John Fischer

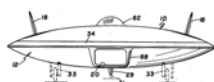

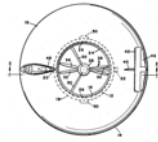

US 2,876,965, Homer Streib



US 2,912,244, Otis Carr



US 2,927,746, Walter Mellen

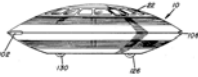

US 2,935,275, Leonard Grayson

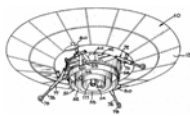

US 2,953,320, Robert Parry

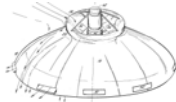

US 2,997,254, Thomas Mulgrave

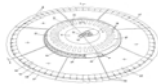

US 3,018,068, Frost & Earl



US 3,020,002, John Frost

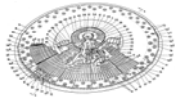

US 3,020,003, Frost & Williams

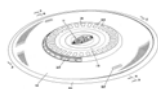

US 3,022,963, Frost & Earl

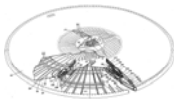

US 3,024,966, John Frost

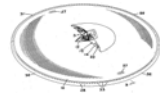

US 3,065,935, Duberry/Frost/Earl

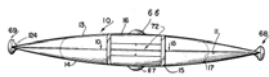

US 3,066,890, Nathan Price

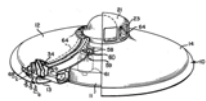

US 3,067,967, Irwin Barr

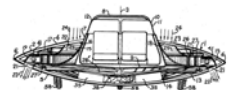

US 3,123,320, Eldon Slaughter

US 3,124,323, John Frost

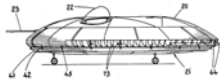

US 3,243,146, Paul Clover

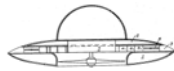

US 3,312,425, Lennon & Varner

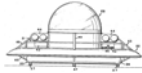

US 3,395,876, Jacob Green

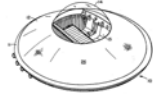

US 3,397,853, William Richardson

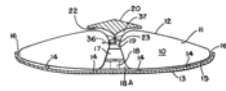

US 3,410,507, Paul Moller

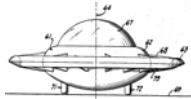

US 3,432,120, Efrain Guerrero



US 3,442,469, Troy Davis

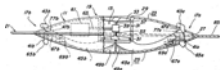

US 3,469,802, Roberts & Alexander

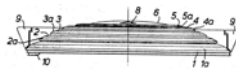

US 3,514,053, Gilbert McGuiness



US 3,519,224, Boyd/Mallory/Skinner

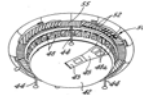

US 3,750,980, Samuel Edwards

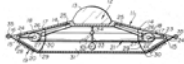

US 3,774,865, Olympio Pinto

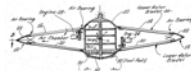

US 3,946,970, Ben Blankenship



US 4,014,483, Roderick MacNeil

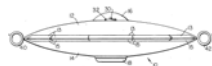

US 4,193,568, Norman Heuvel

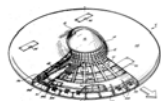

US 4,214,720, Edwin Desautel



US 4,269,375, John Hickey

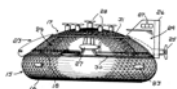

US 4,457,476, Frank Andreseviz

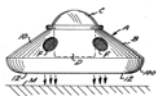

US 4,804,156, Rodney Harmon



US 4,824,048, Kyusik Kim

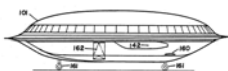

US 4,955,962, Christian Mell

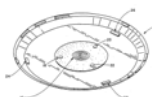

US 5,072,892, Alfred Carrington

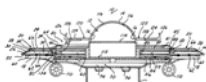

US 5,170,963, August Beck



US 5,178,344, Vaclav Dlouhy

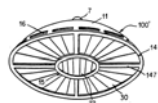

US 5,203,521, Terence Day

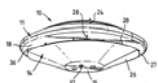

US 5,344,100, Allan Jaikaran



US 5,351,911, George Neumayr

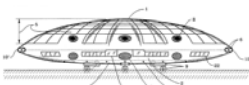

US 6,270,036 Charles Lowe

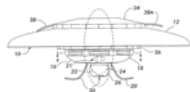

This small selection of forty-six patents is restricted to just those which have the well-known circular “flying saucer” shape. Do you seriously think that not a single one of these patents had a test prototype which flew or that they were all piloted by “little green men”?

I have no interest in flying machines which need an atmosphere as they are just advanced versions of conventional aircraft. In the early 1900s, Nikola Tesla designed and built what he described as his “flying machine”. This was a small device without wings and which ‘flew’ without the use of a fuel. This design of Tesla’s was taken by the Germans and during World War II, developed and experimented with. After the war, it was taken to the USA and developed further at Groome Lake, and at this time, the US, UK, Canadian and Russian governments have got large working copies which they keep as secret as they possibly can. One major cover story is that these craft belong to “extraterrestrials” who have such an advanced level of technology that we will never be able to understand it. It is a good story, as it is not possible to disprove it. If

you want a good deal of specific information on this, then read "The Hunt for Zero Point" by Janes researcher and writer Nick Cook.

While I have no particular interest in electrogravitic propulsion (or "anti-gravity" as it is popularly known and incorrectly termed) if the subject interests you then take a look at the YouTube video sequence of Stan Deyo who was one of the people who developed electrogravitic propulsion for an international group, several decades ago. Stan explains "gravity" as being the product of spin affecting the space-time continuum.

The Karl Schappeller Device

Author: Henry Stevens

Was the Schappeller device an engine used in German field propulsion saucers? This is a possibility. Because so little has been reported about this device in the English language, the following is a report describing Karl Schappeller and his device in some detail.

Karl Schappeller (1875-1947) literally went from being born in poor-house to owning a castle during his lifetime. His economic success was mirrored in his experiments in energy as a lay-scientist, culminating in the invention of a free-energy device which attracted considerable attention around 1930. Schappeller made no secret of his invention and actively sought private financing to manufacture and distribute the results of his research. He was in touch with financial concerns and he even spoke with a representative of the British Admiralty concerning the utilisation of his device to power Royal Navy's ships (1).

At this time, 1930, the device was somehow appropriated and further worked upon by a governmental organisation of the German Weimar Republic, the Reichsarbeitsgemeinschaft or Reich Works Association (RAG). At least one aim of the RAG was to make Germany self-sufficient in energy production. Specifically, they published their intentions to utilise many Schappeller devices in a system of broadcast energy distribution throughout Germany which would result in the entire elimination of the electrical grid (2). As we know, Adolf Hitler assumed power three years later and for strategic reasons, he was also very interested in making Germany independent of foreign sources of energy. It is known that political and scientific structures were set up to work on the energy problem as evidenced later by the synthesising of gasoline and oil products from coal by the 3rd Reich. One of these political and scientific structures was contained within the SS and it is known that Karl Schappeller actually met with SS Reichsfueher Heinrich Himmler in Vienna in 1933 (3).

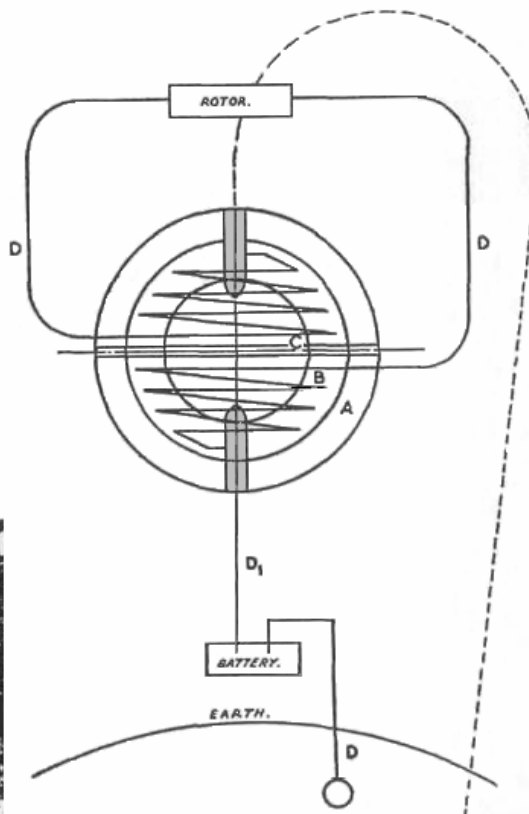

Left: Inventor Karl Schappeller Right: Karl Schappeller's Device. A. Steel outer casing. B. Special ceramic

lining in which tubes are embedded. **C.** Hollow centre, filled by glowing magnetism when in operation.
D. Tubes, circuit and earthing.

Fortunately, there are good descriptions of the Schappeller device upon which to draw in both German and English. Per Vrill-Mythos is a complete discussion of Schappeller, his device, the history and the controversy surrounding it. "Vrill, Die Kosmische Urkraft Wiedergeburt von Atlantis" and "Weltdynamismus Streifzuege durch technisches Neuland an Hand von biologischen Symbolen" represent an attempt by the RAG to popularise their ideas in booklet form. Finally, British electrical and mechanical engineer, Cyril W. Davson, visited Karl Schappeller in Austria and spent three years learning of his device and his theory before the Second World War. Davson's descriptive book, "The Physics of the Primary State of Matter", was written in 1955, after the war and the death of Schappeller.

Before describing the device itself it should be understood that Schappeller and all writing about his device believe that the energy-source being tapped is aether energy, sometimes called "Raumkraft" or "Raumenergie", that is space-energy (4)(5)(6). This device was also said to be capable of, perhaps with some tuning, emitting aether as a radiant energy (7). The physics of aether energy is described by Davson as "primary physics" as opposed to "conventional physics" which he believed could only be considered to be a secondary, derivative understanding.

Aether Theory

For readers who have never heard of "aether", perhaps the simplest explanation for aether physics is that of the late Dr. Hans A. Nieper (7) entitled "Revolution in Technology, Medicine and Society". Aether could be thought of as an energy source emanating from everywhere equally at once. The universe could be considered, as is often said, to be "a sea of energy". It forms a background of energy everywhere, and since it is everywhere all the time, it is difficult make independent measurement of it. This aether energy is in constant motion. All energy is radiant energy, according to this theory. This can easily be appreciated as to electromagnetic radiation but it is also true of that very elusive thing called gravity. Newton described the effects of gravity but he never told us exactly what it was. Dr. Nieper tells us that gravity is really a push, and not a pull. Gravity is acceleration and is caused by the aether field. Again, all energy is radiant-energy whose fundamental basis is aether radiation.

From the aforementioned book by Dr. Nieper:

In addition, Nieper established the axiom that, "all natural accelerations can be attributed to a single unified basic principle, namely, the interception (or braking) of a field energy penetrating from the outside (gravity acceleration, magnetic, electromagnetic, electrostatic and radiesthetic acceleration)".

In trying to explain aether, it might be thought of as an all-pervasive liquid, occupying all of space. This liquid concept is useful because a liquid can not be compressed but can only transfer the energy attempting to compress it from one location to another. This is how the brakes of a vehicle work. The driver presses the brake pedal when he wants to slow down or stop. The plunger of the brake pedal attempts to compress the liquid in the master cylinder. The master cylinder is connected to each wheel by metal tubes full of liquid. When pressure is put on the master cylinder by the driver it is transmitted to each of the four wheel cylinders full of the same fluid which transmits the force, moving the brake mechanism, slowing the wheels of the vehicle.

In a similar way, the aether serves to transmit energy through this "non-compressible" quality. In a primary electric coil and secondary electric coil, for instance, induction in the secondary does not take place directly from the primary as is now said by current physics, but instead, the induction between the two windings is due to the aether field. This concept of the energy transfer function of the aether field is also expressed by Davson.

Using this perspective, that all energy is radiation, the braking of aether radiation, that is the slowing down or stopping of this radiation, can cause a transfer to other forms of energy. The word "energy" means the entire electromagnetic spectrum. That includes, electric, magnetic and electrostatic fields. This means heat. This also means gravity. Again, gravity is the primary radiation of the aether field. It radiates from every point in the universe equally.

This concept seems ridiculous until it is given some thought. One might ask: "How can gravity be a push when we know better?" After all, things fall to earth, don't they? The answer is that the effects which we feel and call "gravity" are due to aether shielding. Aether radiation can be braked, that is slowed down and absorbed by mass. It is then re-radiated or converted into mass. It is re-emitted as slower aether radiation

or even as heat. Some of it can, and is, converted into mass inside a planet. If there is a loss of aether radiation, then there is shielding. Thus, a planet would shield from this radiation in one direction. That direction is always toward its centre which is the direction of greatest mass and that is what we describe as "down". This is simply the area which contains the maximum amount of shielding. In all other directions the aether radiation continues to exert its push on us. The area of minimum shielding is directly opposite the area of maximum shielding, so things fall (or more correctly are accelerated or "pushed") towards the earth.

Think about this for a minute. Being in deep space is rather like being underwater. Underwater, the pressure at all points is so similar that we feel weightless. We are weightless in deep space because the aether field exerts a push on us from all directions equally. In space, the nearer one gets to a large body the stronger the push is from the opposite direction since the body shields or converts the aether radiation. The result of this thinking is a mechanism totally different from "gravity" as we know it but appearing as exactly the same observed phenomena.

The beauty of this aether theory of gravity is that gravity functions like every other form of radiation. Its underlying cause, aether radiation, can be converted to mass or, in certain circumstances, re-radiated or converted to other forms of energy. No Unified Field Theory is necessary. The aether field **is** the unified field. Further, there is no need to look for something separate called "anti-gravity". If gravity is a push then it is all anti-gravity. All we have to do to make a UFO, is to find this particular gravity frequency and find out how to generate it.

Aether physics was a lost physics. Physics was hijacked early in the 20th Century by the alleged results of the Michelson-Morley experiment. This experiment assumed that "aether" was matter. There is some confusion here. We know now that particles moving near the speed of light are measured as waves, that is energy, rather than as matter. Nevertheless, aether theory has been discredited among physicists who, in turn, discredit others who raise the subject. It is only through the efforts of "free-energy devices" and free-energy researchers, that this knowledge is being returned to us. Without this aether theory, the reason these devices work cannot be explained at all. Rejection of aether theory allows these devices to be dismissed as "theoretically impossible" and so "fraudulent" by implication. They are marginalised and dismissed as "perpetual-motion devices". According to established physics, perpetual-motion devices violate the physical laws of conservation of energy. Without an aether theory as an explanation, they do violate the laws of conservation of energy and so their detractors are able to simply dismiss them out of hand. The simple fact that some of these free-energy devices actually work, does not seem to bother these scientists in the least. Rather than change the theory to accommodate the observed facts, the facts are ignored and substituted by dogma. Whether we like it or not, we are living in an energy Dark Age.

Instead of aether theory, we have all been led to focus upon Einstein and his Theories of Relativity. Two or three generations of scientists have wasted themselves on "trying to prove Einstein right". This misguided thinking has resulted in stagnation. One need go no further than the many "free-energy" devices which have arisen to the level of notice in spite of accepted scientific theory to see that this statement is true.

Needless to say, German scientists of the Nazi period laboured under no such illusions. They never abandoned aether physics. This was the fundamental reason why field propulsion UFOs were first developed in Germany. After the Second World War two different sciences developed, both called "Physics". One was the relativity-based concept taught in schools, while the second, more esoteric type, was used secretly, by the secret government, for deep "black projects".

Structure of the Schappeller Device

According to Davson's description, upon which we will rely, the Schappeller device is really composed of two separate units, the rotor and the stator. The stator is constructed as follows: Its surface is round or ball-shaped, being composed of two half-shells of steel. These half-shells contain the internal structure and are airtight. Attached at the "pole" of each half-shell is an iron bar-magnet, most of which is positioned inside the sphere. This means that the bulk of each magnet is inside the steel ball, one opposite the other. There is a space between the two bar magnets at the very centre of the sphere.

An Insulating ceramic material, is placed on the inside of the steel ball, leaving a hollow central area. Within this hollow area, and around the space between the magnets, are two coils are mounted. These start at the pole of the bar magnet and finish at the centre of the sphere, with a connection leading out of the sphere to the rotor. These coils are wound using a hollow copper tube filled with a special, secret substance called the "electret". Upon leaving the sphere, the electret-filled copper tubes are replaced by conventional copper wire. An electrical connection is made from the outside surface of one pole to one pole of a special type of

battery which is grounded at the other pole or, alternatively, to a special device called an "Ur-machine" which will be discussed later.

This electret is a permanent magnet within the sphere. This type of magnetism is not identical with ferromagnetism or electromagnetism, it is much stronger (8). The actual composition of Schappeller's electret remains a secret, but another electret has been made by Professor Mototaro Eguchi. It consists of carnauba wax and resin, perhaps also containing some beeswax. It was kept in a strong electric field while baking slowly until it solidified. For purposes of the production of Schappeller spheres, a complete electret manufacturing plant would have to be set up, which has no parallel in present science (9).

Before being set into operation, all the air is pumped out of the hollow core of the sphere. This whole ball is mounted on a swivel mechanism so that the poles can be moved from the vertical to the horizontal. The stator is not attached to the rotor. The stator can function without the rotor and the stator is capable of producing electrical energy without the rotor. The rotor could also be used to generate additional electrical energy.

The rotor consists of a steel wheel of special design fixed on the shaft to be driven, and surrounded on its outer surface by magnets which are attracted and repelled by the force of the stator. The copper wire attached to the internal electret-filled copper tubing, runs through this wheel and supplies electric power to the magnets. The magnets are hollow and filled with the same electret. There is always an odd number of magnets.

A variant of this rotor comes to us from Taeufer, who refers to this further development as the "Ur-Machine". This machine is composed of six sphere units as described above, five revolving around a sixth one which is positioned either above or below the plane of the other revolving spheres. A seventh unit would be employed to rotate the five rotating spheres and so would be offset, and not attached to the others. The five rotating spheres would charge the sixth stationary sphere. The sixth and seventh spheres would function as an anode and cathode and so ground the unit. The Ur-machine could be used to activate other spheres instead of a battery-earthing procedure (10).

As a prime mover, an engine, the rotor would be used to turn a drive shaft. The stator would be offset, that is, moved off centre in relation to the rotor. Schappeller worked out various angles of efficiency (11). The drive shaft could be used to power any number of machine applications such as, for instance, the propellers of a ship.

Means of Operation

The device is started through a connection to a totally unique battery and a connection to the earth (12). A specific excitation impulse must be given to the device (13). This electric impulse is conducted through the iron magnet and jumps the gap in the centre of the sphere to the other iron magnet.

What occurred then sets this device apart from all others. In the vacuum of the sphere, in the centre space between the two bar magnets a field of "glowing magnetism" is set up. This glowing magnetism is something entirely unique. It is recognised as a magnetic field, but much more powerful and unlike any magnetic field produced by an iron bar or an electric coil. Once the initial input had been made to start the device, the battery and ground can be disconnected. The device then continues to operate on its own (14).

For an understanding of what is really happening here we have to consider the bar magnet. We think of a bar of iron with two poles, one positive and one negative or perhaps one north pole and one south pole. But there are really three components to the bar magnet. There are the two poles and the neutral zone between the poles. If we cut the magnet in half we get two new poles. For the Schappeller device, this neutral zone is very important. Imagine a bar magnet running through the vertical axis of the ball. Then imagine the centre section cut out. We now have a north pole at the top of the ball, a south pole at the bottom of the ball just as we do with the planet Earth. In the centre we have a missing section with a south pole, opposing the north pole at the top of the ball and, likewise, a north pole opposite the south pole at the bottom of the ball. We have now four poles and a split bar magnet with a gap in its centre section.

It is this gap in the centre where Schappeller's "glowing magnetism" is generated by grounding, that is, charging the device via a special battery and an earth connection. This glowing magnetism is the mystery. Davson cites Schappeller's calculations and gives this form of magnetism as being a thousand times more powerful than that produced by present magnetism (15). He also states that in this form of magnetism the electricity is stationary while the magnetism is radiated (16).

To state this again, Davson contends throughout his book that this glowing magnetism is not found in secondary physics, that is, in modern physics, and that this glowing magnetism is a manifestation of primary physics. As a phenomenon of primary physics, it is responsible for, and can generate, heat, electricity and magnetism.

After initial stimulation and in a state of glowing magnetism, no further input of energy is needed from the battery. The device is able to draw in energy to it directly from the surrounding aether, bind this energy through its magnetic electret material, that is the filling in the hollow copper coils of the internal coil, and then re-radiate energy producing heat, electricity, magnetism or mechanical work depending upon the application.

Stated another way, this is an implosion device and it is described as such (17) (18). Unlike the Schauburger device which is associated with the word implosion, the Schappeller device operates purely at the energetic level. Energy is drawn towards the centre, through the magnets, into the field of glowing magnetism, and then radiated outward.

My first explanation for this output of radiant energy involves the concept of the Bloch Wall. A Bloch Wall is defined by Van Norstrand's Scientific Encyclopedia, 1958 edition, pages 201 and 202, as: "This is a transition layer between adjacent ferromagnetic domains magnetised in different directions. The wall has a finite thickness of a few hundred lattice constants, as it is energetically preferable for the spin directions to change slowly from one orientation to another, going through the wall rather than to have an abrupt discontinuity" (18).

In electromagnetics the Bloch Wall is external to the hardware itself. It is the point of division of the circling vortex, or spin, of the electronic magnetic energies of the north and south poles. The negative north pole magnetism spins to the left while the positive south pole spins to the right. Energy is being conducted into the Schappeller device through the un-insulated poles and being conducted and spun on its way to the centre of the unit. The point of zero magnetism, no spin and magnetic reversal, where the two spin fields join, is the Bloch Wall (19).

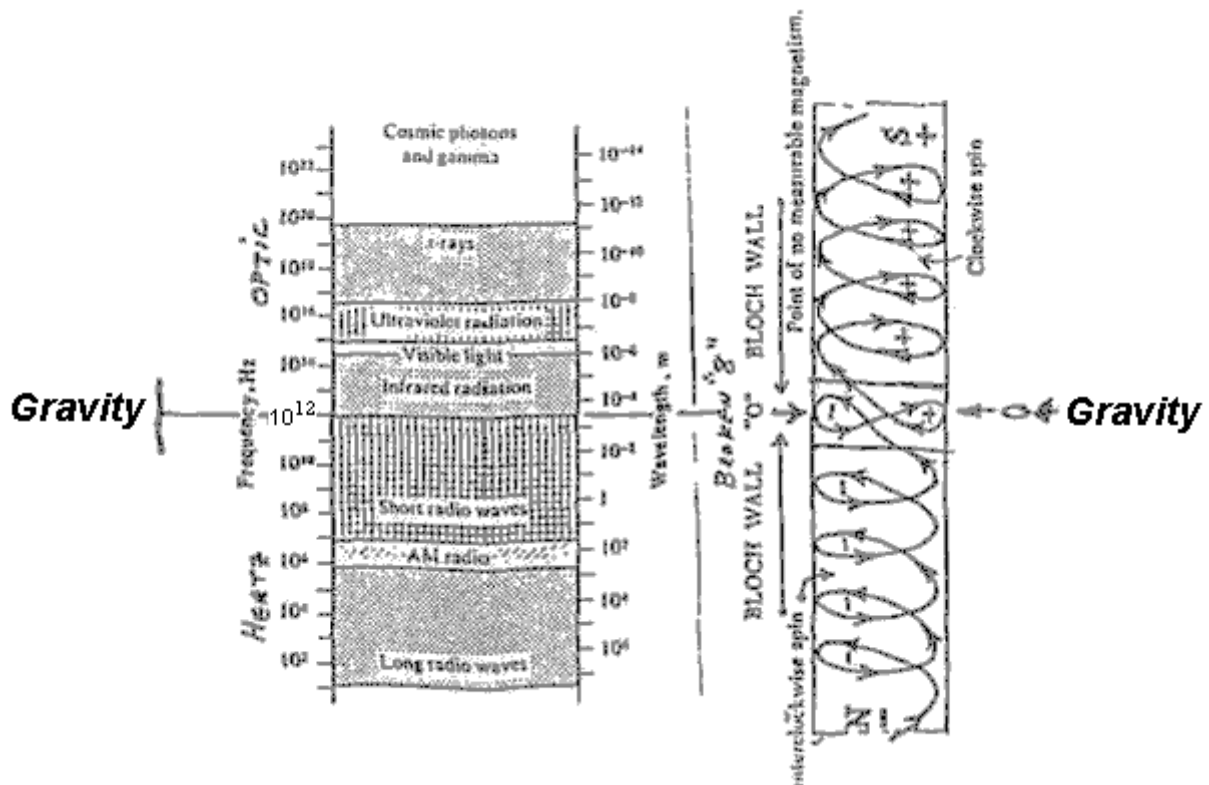

Bloch Wall, a gravity wave source as a function of the electromagnetic spectrum?
(Dr. Richard Le Fors Clark)

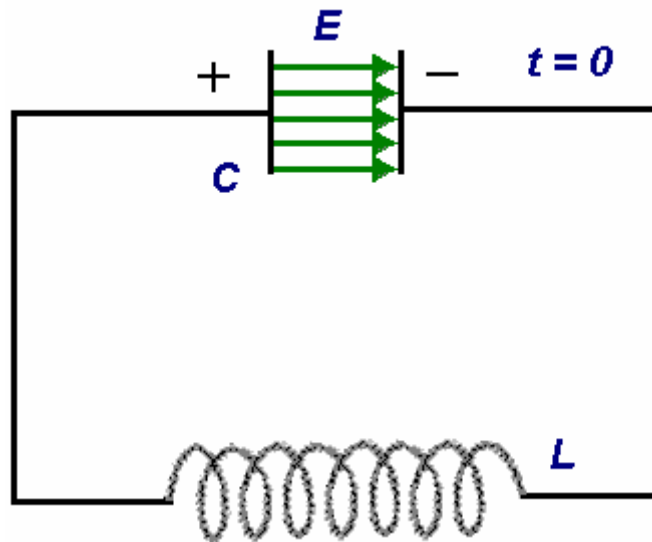

Oscillating circuit. Charged capacitor (electric field) discharges, current carried through insulated wire to charge coil (magnetic field) which discharges, charging capacitor. Oscillating electric and magnetic fields yield electromagnetic waves.

The Block Wall radiates energy. Remember, if energy is coming in then it must be going out. The Bloch Wall may generate radio, radar and other electromagnetic frequencies but what is most interesting is that it is actually able to radiate gravity as according to Dr. Richard Le Fores Clark. According to this interpretation, the conjunction of two dipolar generated force-field vectors, a quadropole force field or gravity is generated according to Dr. Clark. Gravity being a quadropole source, it radiates in a circular, 360^o, pattern of two cycles. Dr. Clark has fixed the point of emission as below that of radar and above infrared at 10¹² Hz (20). Dr. Richard Le Fors Clark believes that gravity is a radiation (20) and so it is a "push".

Another Opinion

In late 2001, I wrote a magazine article on the Schappeller device (20) which contained most of the material described above. In that article, I requested alternative explanations for the Schappeller device. I received a letter from Mr. Michael Watson, BSc, Chartered Physicist and Member of the Institute of Physics in the United Kingdom. But there was something in Mr. Watson's background even more impressive than his professional credentials. Cyril W. Davson was a family friend whom Mr. Watson knew well in his youth and with whom he had discussed Schappeller and his ideas at some length on many occasions. In Mr. Watson's letter was a brief summary of Schappeller's theory in which he cut through most of the confusing terminology.

This summary is important for a couple of reasons. Mr. Watson's summary of Schappeller's aether theory as described by Davson dovetails nicely into the ideas of Schauberger yet seems to allow for Tesla's experimental results on aether as explained by Bill Lyne. The following is what I learned from Mr. Watson's letter:

Most of us have heard of the two Laws of Thermodynamics. These are laws of heat. The First Law of Thermodynamics states that energy is conserved, meaning that the total amount of energy in the universe always remains the same. This is no surprise for most of us and it is not the real concern here.

What is of concern is the Second Law of Thermodynamics which discusses heat and entropy. The word "entropy" might be thought of as a state of randomness or chaos. Negative entropy would then mean movement toward a less random or more ordered state of any particular thing. If we apply this to a system, then entropy tends to increase until the system breaks down in utter chaos. This will occur unless the system is re-charged with additional outside energy. A concrete example of this might be helpful:

Imagine a new car just coming off an assembly line. It has taken a great deal of energy to find, refine, forge, weld, and paint the metal parts of this car. This same concept also applies to all the other components of the car. This energy and organisation constitute a highly organised state, or, in other words, a state of negative entropy.

What happens next illustrates entropy. The car is purchased. Whether it is driven hard or just sits in the

garage does not matter in the long run because what happens to the car is that it starts to fall apart. This change may be small at first and may only occur at the molecular level, but it occurs nevertheless. The engine, transmission, paint, rubber, electronics, etc. all will fail with time. Even if the car just sits in the garage, in a thousand years the metal will eventually oxidise. Finally, the car rusts away forming a reddish brown heap. This is exactly the opposite of the organisation and energy used to put the car together. This disorganisation is entropy. The only thing which will reverse this, as we all know, are additional inputs of energy by the owner in the form of maintenance and repairs.

All things in a relative state of order move toward a state of disorder. In terms of heat, heat will always flow into a colder place from a warmer place. When something is heated there is a rise in its entropy. With increasing heat its molecules move faster and faster in random chaos, just as a bomb does when it explodes. Increasing heat means increasing randomness and chaos which is entropy. Cold, then, can be seen in terms of negative entropy. Any cold object is simply more organised and less random than the same object once it is heated.

Schappeller had something to say about the Second Law of Thermodynamics. He said there was another and unknown thermodynamic cycle which runs opposite the Second Law. To name this idea we will call it "Reverse Thermodynamics". It is the reverse of the Second Law of Thermodynamics in that it leads to an increase in entropy. Not only is there an increase in order but there is an increase in cold! Schappeller, according to Mr. Watson's letter, built his spherical device primarily to demonstrate the principles behind this Reverse Thermodynamics. It was not designed as a practical machine.

To demonstrate the difference between the Second Law of Thermodynamics and Reverse Thermodynamics two theoretical machines shall be examined. Actually, a machine running according to the Second Law of Thermodynamics is not theoretical at all. Combustion machines are of this type. For simplicity sake we will use a wood burning stove such as the type invented by Benjamin Franklin for the heating of a house.

Wood is put in a hollow iron vessel with an adjustable hole at one end. The adjustable hole admits atmospheric oxygen. An initial small input of heat is added to the wood and oxygen until burning occurs. A great deal of heat is produced once the wood begins to burn. We know heat expands. Carbon, carbon dioxide and water vapour are also produced as by-products of the combustion. Entropy is increased. Since entropy is increased, so is pollution so perhaps we all can agree that this is a good example of the destructive technology so characteristic of the world in which we live.

In our example of a theoretical Reverse Thermodynamic machine the by-products of the previous example can be used as fuel. But Schappeller's machine has the additional property of being creative, that is, negatively entropic. Schappeller believed this creative process to be individualistic, so we need a specific template to use as a pattern for this creation. Heat, water, and carbon dioxide are fed into this machine. Quite amazingly, oxygen is yielded as a by-product of this reaction! The heat is also absorbed in Schappeller's Reverse Thermodynamic machine! This absorption of heat is another way of saying that the machine is implosive in nature rather than expansive or explosive as was the heat producing machine. What is most amazing, however, is that entropy is actually reduced yielding, something which has been created - wood!

Actually, this machine is not theoretical either. It exists and works as we speak. These machines are all around us. We call these machines "life". In this case our machine is a tree. In the tree, energy, sunlight, is absorbed and combined in a cold process with water and carbon dioxide to form wood. The template used as a pattern for this seemingly intelligent, creative, process is simply a seed. In this type of reaction the "cold" force is something other than the absence of heat. This cold is an active cold. It is a "densifying", implosive cold. It is a life-giving cold. This is a cold, life giving force. To quote Watson: "This process is life force and the reverse of the second law of thermodynamics; it is the vital force: Vril."

This is one huge difference between the physics of Schappeller and Schauberger and the physics of the Nineteenth Century. The physics of the Nineteenth Century explain everything in terms of the inanimate. Laws of physics are written using inanimate examples. Chemical reactions are described which stem from inanimate models. Animate models are simply made to conform with the inanimate assuming that life is just a special case which eventually will be shown to be nothing but chemistry and so subject to the same Second Thermodynamic Law as the inanimate. Schappeller and Schauberger both say in their own ways that this is not so. They say, each in their own ways, that a new and different law of thermodynamics applies to living forces. They say that this is more akin to a life process than previous theories allow. They say this force is creative. Those who subscribed to these new ideas claimed that it was not only a new physical law but a new science and that Germany would lead the way in this new science. Let us take a closer look at what is claimed to be the physics behind this new science.

The first concept to be considered is cold. Cold in this sense does not mean the mere absence of heat. This is interstellar cold, the cold found in the vacuum of space. In this relative vacuum, matter is not found in sufficient quantity to be used to measure this cold. Think about how we measure cold. We measure matter which is cold. We measure the heat in air or water for instance. In the absence of matter how would cold be measured? There is no doubt that if we could, for instance, place a thermometer in a glass of water in deep space, the temperature recorded would be at or very near absolute zero, 0° Kelvin or -273° Centigrade or -460° Fahrenheit.

The presence or absence of matter in deep space may be the subject of conjecture. The presence or absence of energy in deep space is something universally accepted. For instance, we all know that light passes through interstellar space. We see the proof when we look up at the stars, planets or the moon. Besides visible light, other electromagnetic radiations freely pass through space. These include x-ray, gamma and cosmic rays. Yet besides electromagnetic radiation many people now believe that in the depths of space there resides another form of energy with is found there as well as everywhere else all around us. This energy sometime goes by the name of "zero-point energy" but for our purposes we can simply call it "aether energy". It is sometimes argued that this energy is really the result of aether rather than the aether itself and that aether really is matter. For a moment, let us postpone this discussion and focus on the vast, stretches of interstellar space which are filled with aether energy, near or at absolute zero.

Mr. Watson points out Dawson's words on page 83 of "The Physics Of The Primary State Of Matter" where he says: "Cold is not therefore the absence of heat, primary heat and cold having nothing to do with molecular action (in the cosmos) there are no molecules available".

The reader may recall that something strange happens to electrical energy at absolute zero. For instance, if a disc of conducting material is held at absolute zero and the disc is given an electric charge, the electric current will circulate around and around the disc forever, never losing its energy as it would if the disc were sitting on an office desk at room temperature. This property of cold is instrumental in the storage of at least one form of energy. The vast stretches of cold interstellar vacuum must be seen as a vast energy storage sea in a state of heightened negative entropy. Schappeller called this undirected matter-energy reserve potential "latent magnetism". Out of this latent magnetism, both energy and matter could be produced with the corresponding stimulation. The non-excited electromagnetic field was viewed by Schappeller as simply latent magnetism. Matter is a condensation out of bipolar aether. Therefore, electromagnetism is a product of matter and is nothing more than bipolar aether in a different condition. Latent magnetism could be, then, excited into matter. Latent magnetism could be influenced by either of the thermodynamic principles discussed, the Second Law of Thermodynamics or by Reverse Thermodynamics. This vast aether field, whose most notable characteristic is the property of cold, latent and awaiting stimulus, is the predecessor of both energy and matter as we know them.

Since primary cold, this vast reserve of negative entropy potential, is responsible for both matter and energy and since all energy eventually degenerates into heat, it follows that, as Davson puts it, again on page 83: "Primary heat, as may now be understood, is composed of cold energy". This is seems like a surprising play on words, especially from a man of science, nevertheless, this statement follows perfectly from Schappeller's reasoning.

We turn now to Schappeller's concept of "stress". Both heat stress and cold stress can be applied to an electromagnetic field. Heat stress is the usual type of stress applied to electromagnetic fields in secondary physics. Secondary physics is the physics of our everyday world according to Schappeller. Primary physics is the physics dealing with the cold force and aether yielding matter and energy, which constitute the secondary reactions and so Schappeller uses the term "secondary physics" to describe our world as we know it.

An example of heat stressing of the electromagnetic field is the capacitor and the coil. A charged capacitor produces an electric field and a charged coil produces a magnetic field. A charged capacitor and coil, connected by a wire circuit alternately charge and discharge each other, producing electromagnetic radiation unit the heat caused by the resistance of the wire degrades the whole process into heat. Heat stress on the electromagnetism is +/-.

Cold stress on the electromagnetic field is something totally new to our science and technology. It is also seen in terms of +/- but the machines used to produce it are not known in our world. Mr. Watson did not say this but if we return to our examples of heat stressed machines, the capacitor and the coil, the corresponding cold stressed machines might be the Schappeller sphere and the Schappeller coil electret. The sphere collects the charge through the magnets, holds and condenses it in its glowing centre corresponding to the

electric field of the capacitor. The internal coils filled with electret produce a magnetic field in the presence of the intense and pulsing electric field. According to my interpretation, the whole Schappeller sphere is a combined capacitor/coil combined into one machine made possible through an initial input of cold stress.

As in our example of the capacitor/coil interaction producing an electromagnetic wave, so an attraction exists between a machine obeying the Second Law of Thermodynamics and one obeying the law of Reverse Thermodynamics. This attraction can lead to interaction. For example, an imploding or centripetal vortex can couple with an exploding or centrifugal vortex. The centripetal vortex is an example of a system following the law of Reverse Thermodynamics while the centrifugal vortex represents system following the Second Law of Thermodynamics. We have all seen these two systems working together in everyday life. The common toilet is such a machine although the centrifugal side forms inside the drain pipe which is out of sight.

Perhaps there is another example which is more germane to our discussion. It is the diagram of the Vrill power plant. (This engine diagram is used here as an example for discussion and is not a blind endorsement of the diagram's existence or accuracy.)

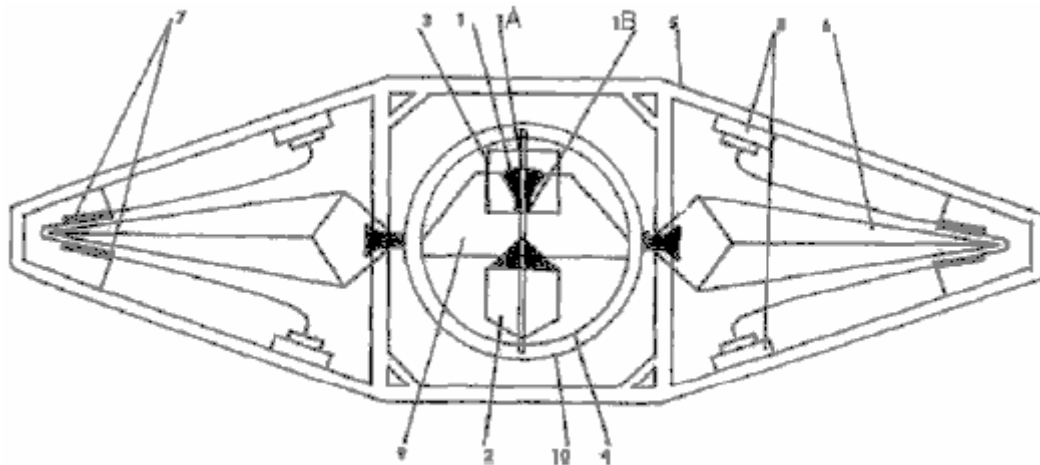

Internal plans for a "Vrill-1" saucer, according to Polish historian Igor Witkowski.

In this interpretation of this diagram, we are really dealing with two separate devices. First, is the central spherical device which may be a refined version of the Schappeller sphere. An initial charge would be imputed into the sphere to start it after which the unit would continue to gather up the surrounding energy. This is a Reverse Thermodynamic machine. The sphere generates a magnetic field which could be offset by rotating the Schappeller device. The offset field would feed and so rotate the arms of the electric generator surrounding the sphere. The electric generator would gather electric energy, feeding the four large broadcasting fixtures on the walls of the saucer. These fixtures might be, for instance, Tesla pancake coils. The electric generator is an example of a machine complying with the Second Thermodynamic Law.

Both components of the power plant are bonded together in a single system since the output energy of the broadcasting fixtures on the walls of the saucer constitute additional input energy for the sphere. The two components attract one another and use and depend upon one another as they circulate and recirculate energy. As the energy level of one component increases so does the energy level of the other. Indeed, the biggest problem facing the use of such an engine may be getting some means of stopping it.

The actual levitation might be the particular electromagnetic radiation coming out of the sphere. In this interpretation, the broadcast fixtures are used to steer the saucer. Davson gives output frequencies for the sphere as 10^6 (20).

Mr. Watson points out in his letter that one reason machines utilising the Reverse Thermodynamic principle have not been recognised is that a cold stressed magnetic field is a cold machine. Even a centripetal vortex cools rather than heats. All our devices of measurement ultimately measure heat in some form. Measurement of cold is more difficult. The example already given, the problem of measuring temperature in interstellar space in the absence of matter is an example of this problem.

Finally, the reader will recall that Mr. Watson points out that electromagnetism itself manifests bipolarity, yielding four components in all. These are +/- hot electromagnetism and +/- cold electromagnetism. The reader will recall that two hot electromagnetic components can be joined (the capacitor and the coil) and set

into a cycle producing an electromagnetic wave. Is it possible that two complementary hot electromagnetic and cold electromagnetic machines could be set into cycle producing not a bi-polar but a quadropolar, 360° radiation to produce gravity, such as the one described by Dr. Richard Le Fores Clark?

Planned Uses for the Schappeller Device

If the above discussion has any meaning at all in the quest for an answer to the UFO question, one use for which the Schappeller device must have been destined was that of a power plant for a flying machine. Was this so? The Schappeller device had many planned uses. In 1930 this device was planned as a source of broadcast energy, reminiscent of Tesla, for both German homes and industry. The device could also be used as a generator, battery, transformer, or antenna (21). It is reported that toward the end of the war the SS researched the possibility of using this device in the form of a death ray (22). But additionally, and in answer to our question, the Schappeller device was envisioned as a levitation device for a flying machine. Here is some of that discussion from our sources:

"The new dynamic technology will, in the future, be able to drive electric locomotives and cars without the manufacture of costly armatures and everywhere through connection to the atmospheric voltage network. Hypothetically, is certainly the installation of a sufficient number of central amplification facilities which transports from the Ur-Machine the specific magnetic impulse from the dynamic spherical element. New types of aircraft with magneto-static power devices and steering, which are completely crash and collision proof, could be built for a fraction of the cost of today's aircraft and without the lengthy training of everyone who will be servicing these aircraft". (From "Vril Die Kosmische Urkraft Wiedergeburt von Atlantis" by Johannes Taeufer, page 48).

"Our goal must be to drive forward the space ship problem to new understanding and realisation! Here a definite postulate can be established: "A spherical space ship with its own atmosphere" also technical creation of small planets with world dynamic propulsion and buoyancy!. Will this be possible? -- Major powers in the world prepare themselves in any case presently, especially in Germany."

The above from "Weltdynamismus Streifzuege durch technisches Neuland an Hand von biologischen Symbolen" pages 11 and 12. Please note the use of the words "spherical space ship"(Kugelraumschiff).

From Davson's "The Physics Of The Primary State Of Matter", page 240: "The Rotor is laminated to prevent eddying and the magnets do not project; the Rotor periphery is thus entirely equi-radial. The Rotor is fixed to the shaft to be driven and the Stator is fixed about a metre above the earth's surface. The latter is, of course, flexible because the earth can include the sea or even the floor of an aether-ship."

From Davson, page 199: "As has already been explained, the new Technique will not concern itself with the air as a supporting medium, but directly with the aether. Therefore, the body may be a vertical sealed cylinder with conic ends or any other suitable form. Such a body is obviously rigid and inelastic, and it must contain an aether stress of sufficient intensity to support its mass against thither stress of the earth's stress field, which means that the glowing magnetism core in the Stator, provided in the body to be lifted, must be able to vary its intensity according to the height at which the aether-ship is to be raised and supported whilst in transit, as the aether stress or field, itself, varies inversely as the square of the distance from the earth's surface. The actual design and solution of all the various problems in the production of such ships, the choice of methods of propulsion, whatever independent or directional, belong to the new Technique, whereas here we are only interested in the principle as applied to the problem of Gravitation."

Finally, from Davson, page 177: "Now the reason that an unsupported body falls to the ground is primarily because it has "no hold" on the medium. It was previously explained that any inert mass or body has only a latent stress field which functions merely as the force of cohesion and has no mobility and thus only a latent internal stress field and no external stress field. This means that it has no "hold" on any elastic medium such as the aether or the air, therefore it must fall, and it falls towards the greater inductive energy."

If the inductive energy, through some exterior cause, could be made suddenly to increase enormously, there would come a point when the body would be supported, or rather suspended, before it reached the earth's surface. The new Technique could accomplish this by placing a Schappeller Stator in the body in question, where the body is suitably constructed, thus setting up a glowing magnetic stress field which would hold or keep the weight or mass of the unit body suspended, not in the air "the stress field would have no reaction on the air" but only on the earth's magnetic stress field. This is the basis of the new principle for 'aether ships'".

Employing the Schappeller mechanism is only half the total explanation. In a field propulsion saucer there are possible two types of "drive" needed. The first is the "Auftrieb" or levitation. Employment of levitation makes the craft buoyant. It weighs nothing. If it weighs nothing it can be moved very easily. "Antrieb", impulse or motive power is the second drive involved. It moves the craft directionally. Levitation only would be supplied by the Schappeller system. Directional movement is so far best explained, in my mind, using the Tesla pancake coils as explained by Bill Lyne.

Concluding Thoughts on the Schappeller Device

In the end, what can be said of the Schappeller device? Certainly, it did exist. It drew attention and funding from people within the German government of the time. It was studied by a qualified outsider, a British engineer, for a period of three years and was judged to be genuine.

However, there are some obvious problems. Exotic energies have been evoked which have not been explained satisfactorily. Therefore, the facts are not yet proven. Certainly more proof is required before the claims made for this device or the energies involved can be wholly accepted. For the time being we must put this discussion aside, awaiting further correlations.

There are some solutions connected with this device also. If we accept the idea that both the Schauburger and the Schappeller devices worked on the theory of implosion, then one explanation will serve to explain them both. It also allows for an aether-as-matter explanation. This may fit into the evidence gathered by Nikola Tesla. The commonality of these devices could then be sought and perhaps a more efficient device built as a result. We will pick up this theme again in the discussion section of this book.

It should be pointed out that the quest for this "new science" is not specific to Schappeller or Schauburger. Mr. Watson passed on these words from Ehrenfried Pfeiffer, a scientist who collaborated with Dr. Rudolf Steiner around 1920. Although he is not happy with the translation, he sent it as he found it which is as it is presented here:

"...the method of science, in a materialistic sense, is based on analysis splitting apart, disintegration, separation, dissecting and all the procedures which have to destroy and take apart, to work on the corpse rather than to grow, to develop, to synthesise. That the human mind was captured by these methods of braking apart: in that I saw the source of our present situation. My question (to Rudolf Steiner) was therefore: is it possible to find another force or energy in nature, which does not have in itself the objective of atomising and analysis but instead builds up, and synthesises? Would we discover that constructive force, which makes things alive and grow, develop adequate building up of methods investigation, eventually use this force for another type of technique, applied to drive machines, than because of the inner nature of this force or energy we might be able to create another technology, social structure, constructive thinking of man rather than destructive thinking? This force must have the impulse of life, of organisation within itself as the so-called physical energies have the splitting, separating trend within themselves."

My question to Rudolf Steiner in October 1920 and spring 1921 therefore was: "Does such a force or source of energy exist? Can it be demonstrated? Could an altruistic technology be build upon it?"

My questions were answered as follows: "Yes, such a force exists, but is not yet discovered. It is what is generally known the aether (not the physical aether) but the force which makes things grow, lives for instance in the seed as Samenkraft. Before you can work with this force you must demonstrate its presence. As we have reagents in chemistry, so you must find a reagent for the aetheric force. It is also called formative aetheric force because it is the force which relates the form, shape, pattern of a living thing - growth. You might try crystallisation processes to which organic substrata are added. It is possible then to develop machines, which react upon, and are driven by, this force. Rudolf Steiner then outlined the principles of the application of this force as source of a new energy..."

Since this quest for a new science with the accompanying new machines had a relatively long history in Germany, certainly pre- dating the 3rd Reich, it is almost certain that the Schappeller device or others built along a similar understanding were further developed during the Nazi period. What became of it after the war is not known. It can be assumed that this device did not escape the scrutiny of the numerous Allied intelligence units tasked with combing Germany for examples of German science. Perhaps someday a government report will be de-classified explaining all this as it was in the case of another free-energy machine, that being the Hans Coler device, which was declassified by the British in 1978 (23) and which worked, according to Mr. Watson, using the same principles of cold magnetism. Until that final reckoning comes, aspects of the Schappeller device will still remain a mystery. And until a more final reckoning comes,

the question of whether or not the Schappeller device was used as a source of field propulsion in German flying saucers, must be deferred.

Sources and References

1. Bahn, Peter, Ph.D. and Heiner Gehring, 1997, pages 120-131, Per Vril-Mythos Eine geheimnisvolle Energieform in Esoterik, Technik und Therapie, Omega Verlag, Duesseldorf
2. Taeufer, Johannes, 1930, page 31. "Vril" Die Kosmische Urkraft Wiedergeburt von Atlantis, commissioned and distributed by the Reichsarbeitsgemeinschaft "Das kommende Deutschland", Astrologischer Verlag Wilhelm Becker, Berlin-steglitz
3. Bahn/Gehring, 1997, page 131
4. Bahn/Gehring, 1997, pages 120-124, 130
5. Weltdynamismus Streifzuege durch technisches Neuland an Hand von biooaischen Symbolen, 1930. pages 14-15, commissioned and distributed by the Reichsarbeitsgemeinschaft "Das Kommenden de Deutschland", Otto Wilhelm Barth Verlag, Berlin
6. Davson, Cyril W., 1955, pages 50-59, The Physics Of The Primary State Of Matter And Application Through the Primary Technique, Elverton Books, London
7. Nieper, Hans A., Ph.D., 1985, Conversion of Gravity Field Energy/Revolution in Technology. Medicine and Society. M.I.T. Management Interessengemeinschaft fuer Tachyonen-Geld-Energy GmbH, Friedrich-Rueder-Strasse 1, 2900 Oldenburg, Germany (available in German and English language versions)
8. Davson, Cyril W., 1955, pages 212-213
9. Davson, Cyril W., page 231
10. Davson, Cyril W., pages 217, 223
11. Taeufer, 1930, pages 30-32
12. Davson, 1955, page 230
13. Davson, 1955, page 226
14. Taeufer, 1930, page 30
15. Taeufer, page 32
16. Davson, 1955, page 231
17. Davson, 1955, page 231
18. Davson, 1955, page 57
19. Taeufer, 1930, pages 38-40
20. Clark, Richard Le Fors, Ph.D., 1987, page 64, "The Earth Grid, Human Levitation And Gravity Anomalies", contained in Anti-Gravity And The World Grid edited by David Hatcher Childress, Adventures Unlimited Press, Stelle, Illinois
21. Stevens, Henry, 2001, "Infinite Energy", pages 9-13, Volume 7, Issue 40
22. Davson, 1955, page 244
23. Bahn/Gehring, 1997, page 115
24. British Intelligence Objectives Sub-Committee Final Report Number 1043, item number 31, "The Invention Of Hans Coler, Relating To An Alleged New Source Of Power, Bryanston Square, London

Condensation-Induced Water-Hammer.

There is another little-known effect which has a high potential for being a useful technique, and this is the water hammer effect produced by the sudden condensation of steam. Under suitable conditions, the effect can be harnessed to provide motive power.

THE UNDERWATER JET ENGINE

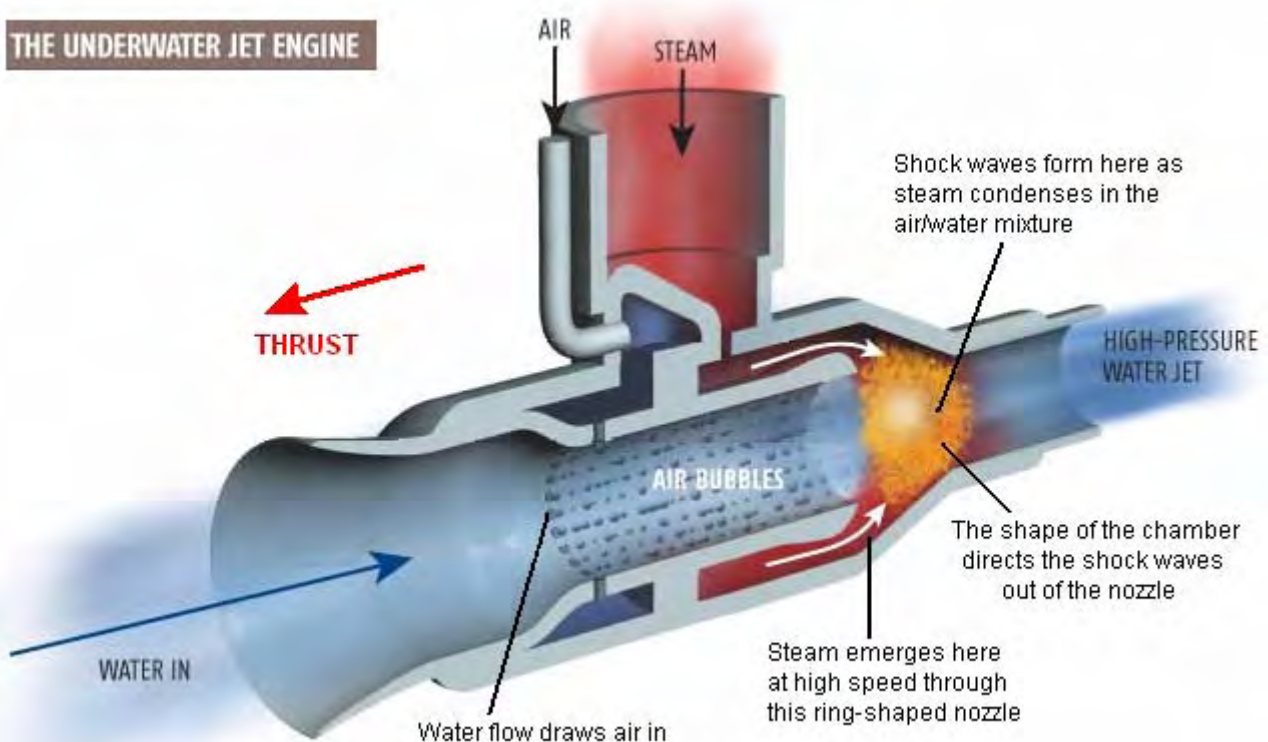

One of the techniques which has been used is shown above. Here, steam under 55 psi pressure is forced into a tubular structure through a ring orifice. That steam then passes through a doughnut-shaped nozzle where it hits a stream of heavily aerated water. The bubbles in the stream of water are drawn in by the venturi effect of the water flow past small apertures in the tube. The result is a rapid series of water hammer shock waves which, because of the shape of the shock wave chamber, boost the water as it exits from the tube. This produces a thrust in the opposite direction, effectively forming a jet engine which is particularly suited to water-borne vessels. In the diagram shown above, the device shown is designated as an Underwater Jet Engine. The diagram is from the web display at: http://www.newscientist.com/data/images/ns/cms/dn3321/dn3321-1_843.jpg and is copyright of the New Scientist.

Further information on this form of energy can be found at:

<http://www.kirsner.org/pages/condInduceWatHamText.html> and

<http://www.energeticforum.com/renewable-energy/3093-condensation-induced-water-hammer>

William Hyde's 10 Kilowatt, COP=10, Electrostatic Power Generator.

This is best described by his patent, a slightly re-worded version being shown here:

This patent describes a device which can be a little difficult to visualise and so some colour shading of parts has been used to help matters. Essentially, it is two circular rotors spinning inside a section of plastic pipe. These rotors generate electrostatic energy which people have mistakenly been led to believe is not a source of significant power. This design by William Hyde has an electrical output which is some ten times greater than the mechanical input power required. A Coefficient Of Performance = 10 result like this, has to be significant, especially since the device is of fairly simple construction.

Electrostatic energy field power generating system

Patent US 4,897,592

30th January 1990

Inventor: William W. Hyde

Abstract:

Externally charged electrodes of an electrostatic generator induce charges of opposite polarity on segments of a pair of confronting stators by means of electric fields within which a pair of rotors are confined during rotation to vary the charge binding field linkages between confronting rotors and stators by a shielding action of the rotors in a plane perpendicular to the field flux. A high electric potential difference induced between the stators resulting from such rotation of the rotors, is transformed by an output circuit into a reduced DC voltage applied to a load with a correspondingly increase current conducted through it.

US Patent References:

2522106	Electrostatic machine	Sep 1950	Felici	310/309
3013201	Self-excited variable capacitance electrostatic generator	Dec 1961	Goldie	322/2A
4127804	Electrostatic energy conversion system	Nov 1973	Breaux	322/2A
4151409	Direct current variable capacitance electric generator	Apr 1979	O'Hare	250/212
4595852	Electrostatic generator	Jun 1986	Gundlach	310/309
4622510	Parametric electric machine	Nov 1986	Cap	322/2A

Description:

This invention relates to the generation of electrical power by conversion of energy from an electrostatic field. The conversion of energy from a static electric field into useful electrical energy by means of an electrostatic generator is already well known in the art as exemplified by the disclosures in U.S. Pat. Nos. 2,522,106, 3,013,201, 4,127,804, 4,151,409 and 4,595,852. Generally, the energy conversion process associated with such prior art electrostatic generators involves the input of mechanical energy to separate charges so that a considerable portion of the output is derived from the conversion of mechanical energy.

It is therefore an important object of the present invention to provide an electrostatic generator in which electrical power is derived from the energy of static electric fields with a minimised input of mechanical power.

Summary:

In accordance with the present invention, static electric fields are established between electrodes externally maintained at charge levels of opposite polarity and a pair of internal stator discs having segmental surfaces that are dielectrically spaced to confine thereon charges induced by the electric fields. A pair of rotor discs are rotated within continuous electric fields in planes perpendicular to the field flux to locationally vary the charge linkage established by the electric fields between the electrodes and stator discs. Such changes in charge linkage are effected by rotation of electrically conductive segments of the rotor angularly spaced from each other to partially shield the stator discs from the electric fields. The segments of each rotor disc have charged faces confronting the electrodes in its field to shield the stator disc over a total face area that is one-half the total area of the confronting segment surfaces on the stator disc to which the induced charges are confined. Charges on the rotors and stators are equalised by electrical interconnections established through the rotor shafts. The stator discs are electrically interconnected with an electrical load through an output circuit transforming a high potential between the stator discs into a reduced dc voltage to conduct a correspondingly multiplied current through the load.

Brief Description of the Drawings:

These and other objects and features of the present invention will become apparent from the following description taken in conjunction with the preferred embodiments thereof with reference to the accompanying drawings in which like parts or elements are denoted by the same reference numbers throughout all of the different views shown in the drawings and where:

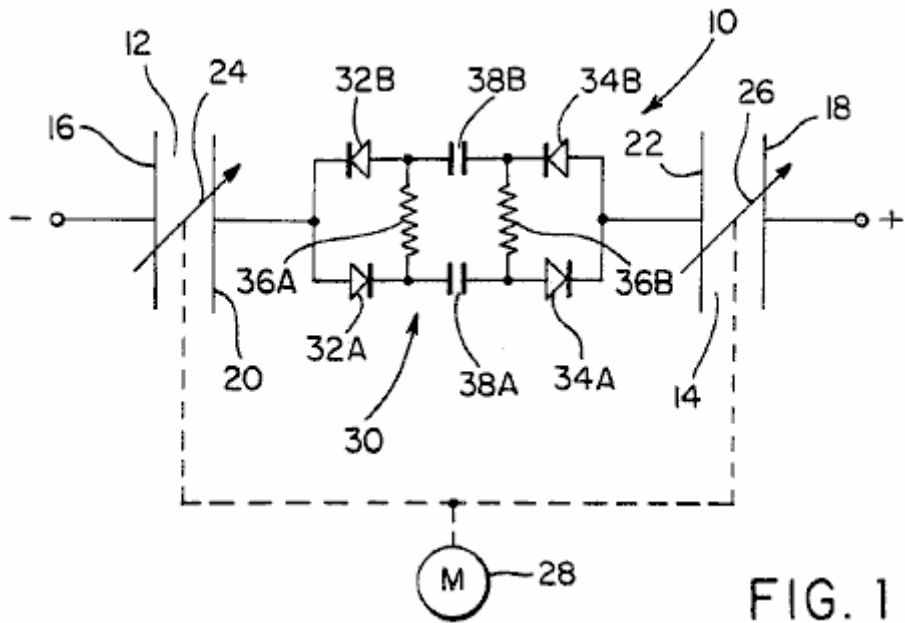

FIG. 1

Fig.1 is a simplified electrical circuit diagram corresponding to the energy conversion system of the present invention.

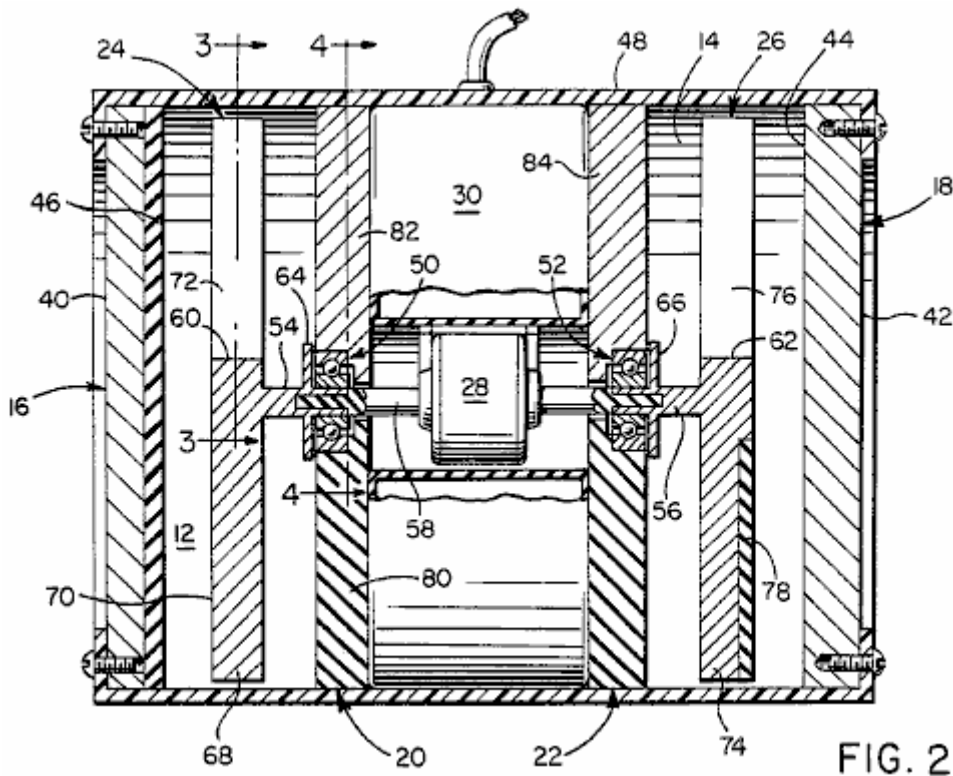

FIG. 2

Fig.2 is a side section view of an electrostatic generator embodying the system of Fig.1 in accordance with one embodiment of the invention.

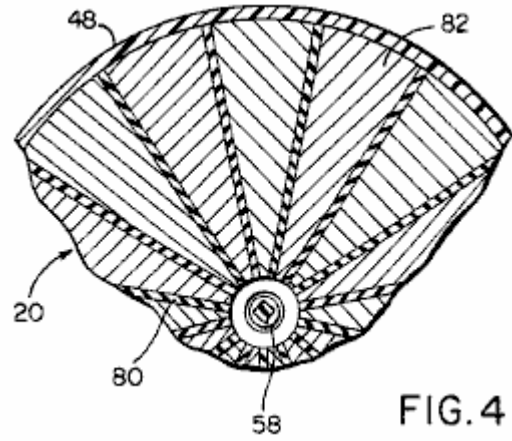
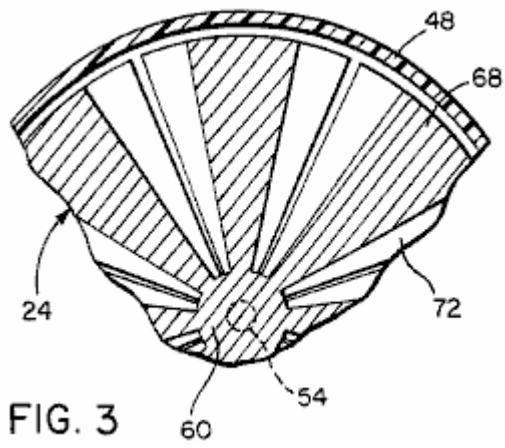

Fig.3 and **Fig.4** are partial section views taken substantially through planes indicated by section lines 3--3 and 4--4 in Fig.2.

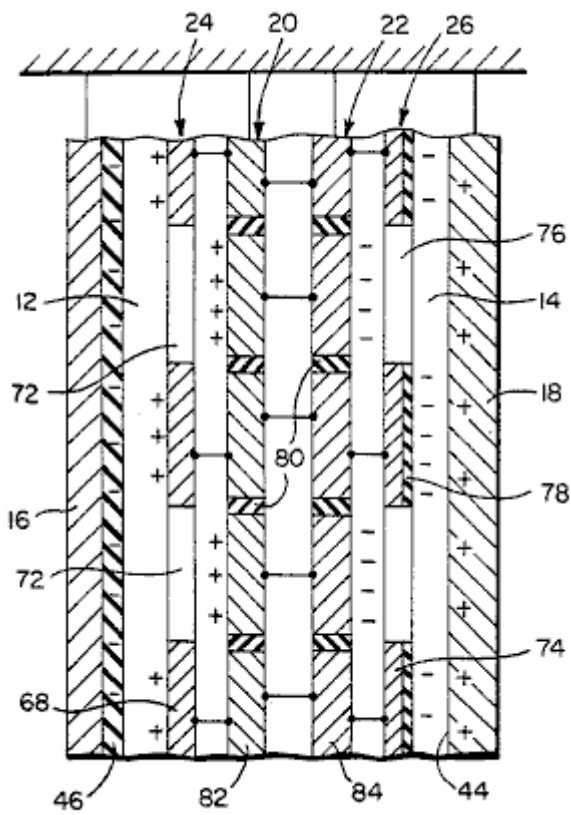

FIG. 5A

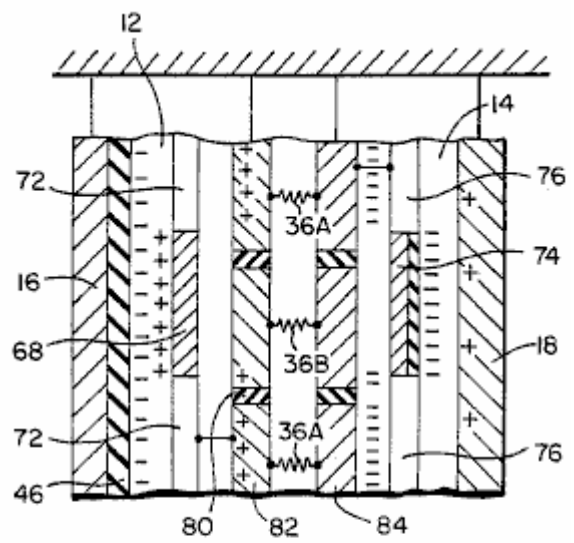

FIG. 5B

Fig.5A and **Fig.5B** are schematic partial laid out top views of the electrostatic generator of Figs.2-4, under static and dynamic charge distribution conditions, respectively.

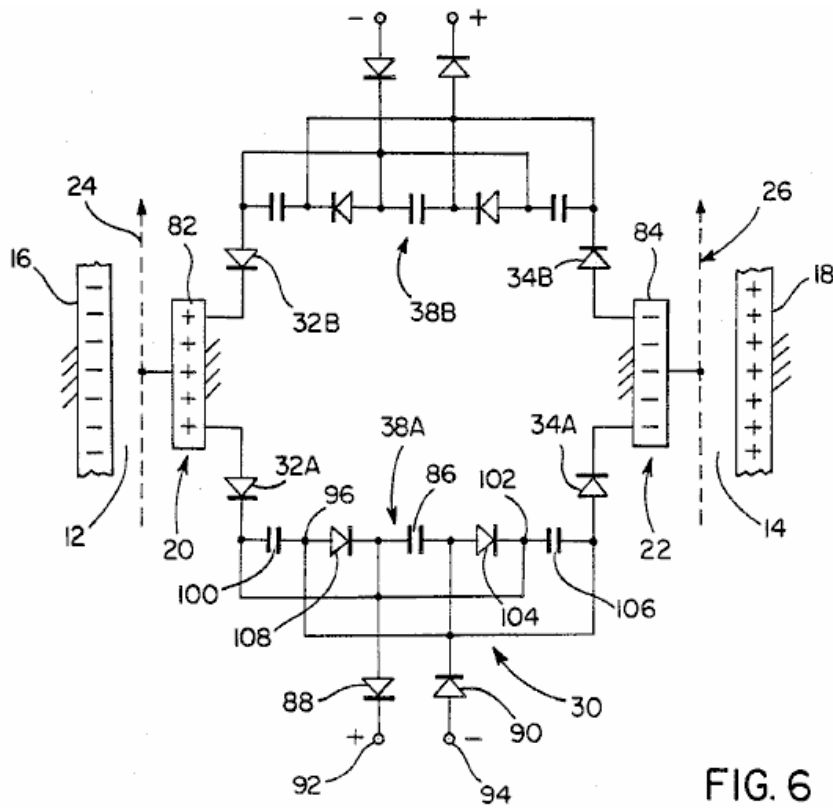

FIG. 6

Fig.6 is an electrical circuit diagram of the output circuit of the generator shown in Fig.2, in accordance with one embodiment.

Detailed Description of the Preferred Embodiment:

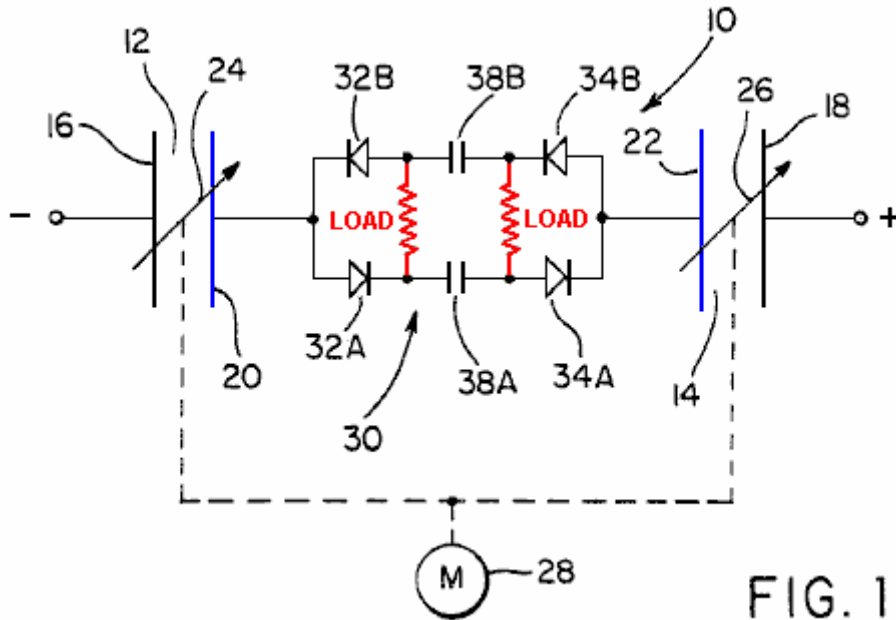

FIG. 1

Referring now to the drawings in detail, **Fig.1** diagrammatically depicts the energy conversion system of the present invention generally referred to by reference numeral 10. As shown in **Fig.1**, the system includes a pair of electrostatic fields 12 and 14 established by electrostatic charges of opposite polarity applied to electrode plates 16 and 18 from some external energy source. Thus, the electrostatic field 12 is established between electrode 16 and a stator disc 20 while the electrostatic field 14 is established between electrode 18 and a stator disc 22. In accordance with the present invention, electrostatic charge linkages established by the flux of the fields between the electrodes and stators are periodically varied by displacement within the continuous energy fields 12 and 14 in response to rotation of rotors 24 and 26 aligned with planes perpendicular to their common rotational axis and the field flux, as will be described.

The rotors are mechanically interconnected with an electric motor **28**, as diagrammatically illustrated in **Fig.1**, which rotates them around their common axis. Electrical energy may be extracted from the electric fields **12** and **14** during rotation of the rotors **24** and **26** (by motor **28**) through an output circuit generally referred to by the reference number **30**. The output circuit **30** as shown in a simplified fashion in **Fig.1**, includes two pairs of current-conducting diodes **32A**, **32B** and **34A**, **34B**. The diodes of each pair are connected with opposite polarity and each pair is connected in parallel to one of the stators **20** and **22**. The diodes of each pair are also electrically connected across an electrical load represented by resistors **36A** and **36B** with capacitor networks **38A** and **38B** interconnected between each pair of diodes by means of which the voltage potential between the stators **20** and **22** is reduced in favour of an increased current through the electrical load.

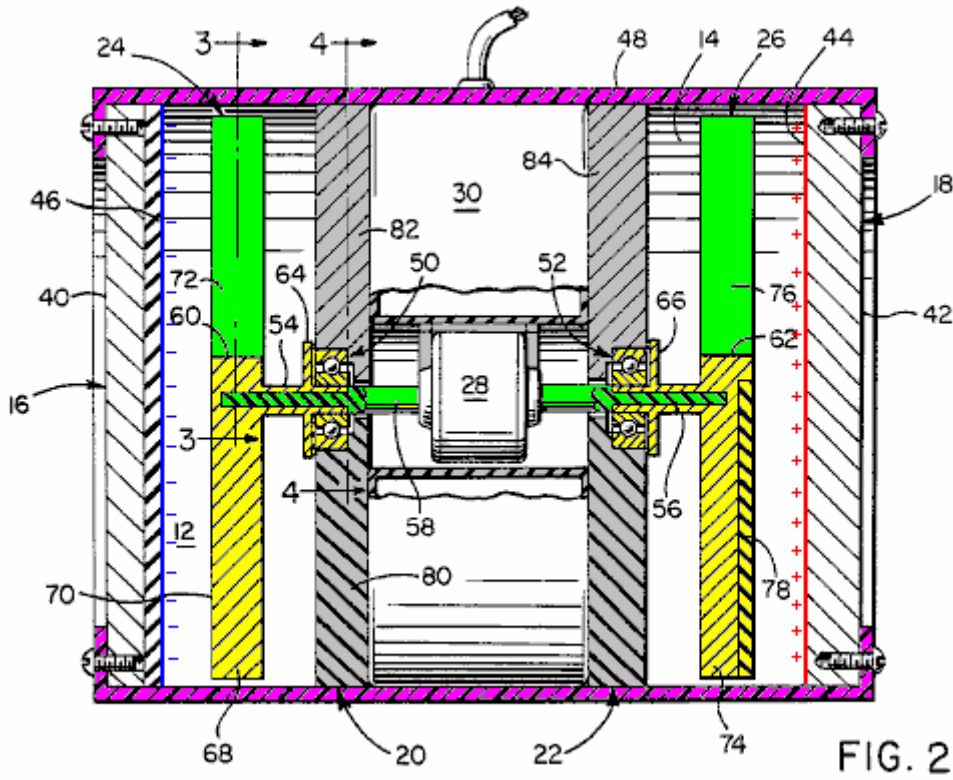
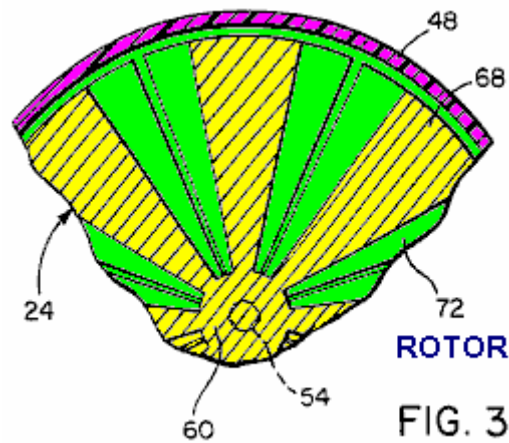

FIG. 2

Referring now to **Figs 2, 3** and **4** in particular, a physical embodiment of the energy conversion system shown in **Fig.1** is shown. The electrodes **16** and **18** are in the form of circular plates or discs made of an electrically conductive metal having external surfaces **40** and **42** adapted to be charged from the external source as already mentioned. The internal surface **44** of electrode **18** is thereby adapted to maintain a positive charge opposite in polarity to the negative charge of the electrode **16** which is maintained in a stable ion form within a dielectric surface portion **46** of the electrode **16**. The energy conversion system may be enclosed within an outer housing **48** to which the electrodes **16** and **18** are secured.

With continued reference to **Fig.2**, the stators **20** and **22** mounted by housing **48** in axially fixed spaced relation to the electrodes **16** and **18** are provided with bearings **50** and **52** supporting the powered rotor shaft driving the shaft assembly which has electrically conductive shaft sections **54** and **56** to which the rotors **24** and **26** are respectively connected. In the embodiment illustrated in **Fig.2**, the drive motor **28** is mechanically interconnected with the shaft sections **54** and **56** through an electrically nonconductive shaft section **58** of the power shaft assembly for the simultaneous rotation of both rotors **24** and **26** at the same speed and in the same direction about their common rotational axis perpendicular to the parallel spaced planes with which the electrode and stator discs are aligned. The electrically conductive shaft sections **54** and **56** are respectively keyed or secured in any suitable fashion to hub portions **60** and **62** of the rotors and are provided with flange portions **64** and **66** forming electrical wipers in contact with confronting surfaces of the stators **20** and **22**, which are inductively charged by the static electric fields **12** and **14** to equal levels of opposite polarity.



As more clearly seen in **Fig.2** and **Fig.3**, the rotor **24** has several angularly spaced, field linkage controlling segments **68** projecting radially outwards from the hub portion **60**. Each rotor segment **68** is made of an electrically conductive metal having a face **70** on one axial side confronting the adjacent electrode **16**. The faces **70** confronting the electrode **16** are charged positively by the electric field **12** extending between the dielectric surface portion **46** of electrode **16** and the stator disc **20**. While the electric field **12** projects through the spaces **72** between the rotor segments **68**, the rotor segments **68** themselves shield portions of the stator disc **20** from the electric field.

The rotor **26** is similarly formed with rotor segments **74** angularly spaced from each other by spaces **76** through which the electric field **14** extends between the positively charged surface **44** of electrode **18** and the stator **22**. The rotor segments **74** of rotor **26** as shown in **Fig.2**, are provided with dielectric surface portions **78** confronting the internally charged surface **44** of electrode **18**. While the rotor segments **74** are negatively charged by the electric field **14** within the surface portions **78**, they also shield portions of the stator disc **22** from the electric field as in the case of the rotor segments **68** already described. The internal dielectric surface portion **46** of electrode **16** and dielectric surface portions **78** of rotor **26** act as a stabiliser to prevent eddy currents and leakage of negative charge. Further, in view of the electrical connections established between the rotors and the stator discs, the charge on each stator is equalised with that of the charge on its associated rotor.

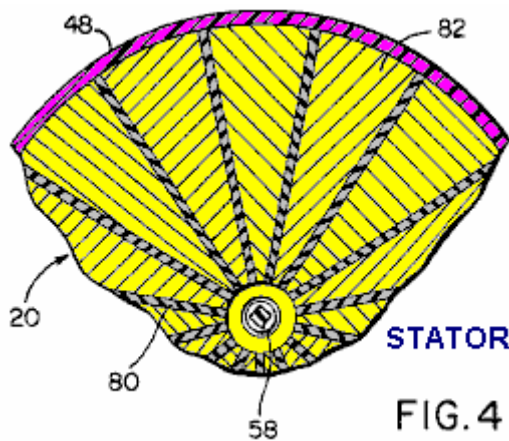

As shown in **Fig.2** and **Fig.4**, the stator disc **20** includes several segments **82** to which charges are confined, closely spaced from each other by dielectric spacers **80**. The segments **82** are electrically interconnected with the rotor segments **68** through rotor shaft section **54**. Similarly, the segments **84** of the stator **22** are electrically interconnected with the rotor segments **74** through rotor shaft section **56**. The stator segments **82** and **84** are therefore also made of electrically conductive metal. Each of the segments **82** of stator **20** is electrically interconnected through the output circuit **30** with each of the segments **84** of the stator. The stator discs being fixedly mounted within the housing **48**, centrally mount the bearings **50** and **52** through which the electrically nonconductive motor shaft section **58** is journaled as shown in the embodiment of the invention illustrated in **Fig.2**. Further, the total area of the charged segment surfaces on each of the stator discs is greater than the total area of the faces **70** or **78** on the segments of each associated rotor disc **24** or **26**. According to one embodiment, the total charged stator surface area is twice that of the rotor face area.

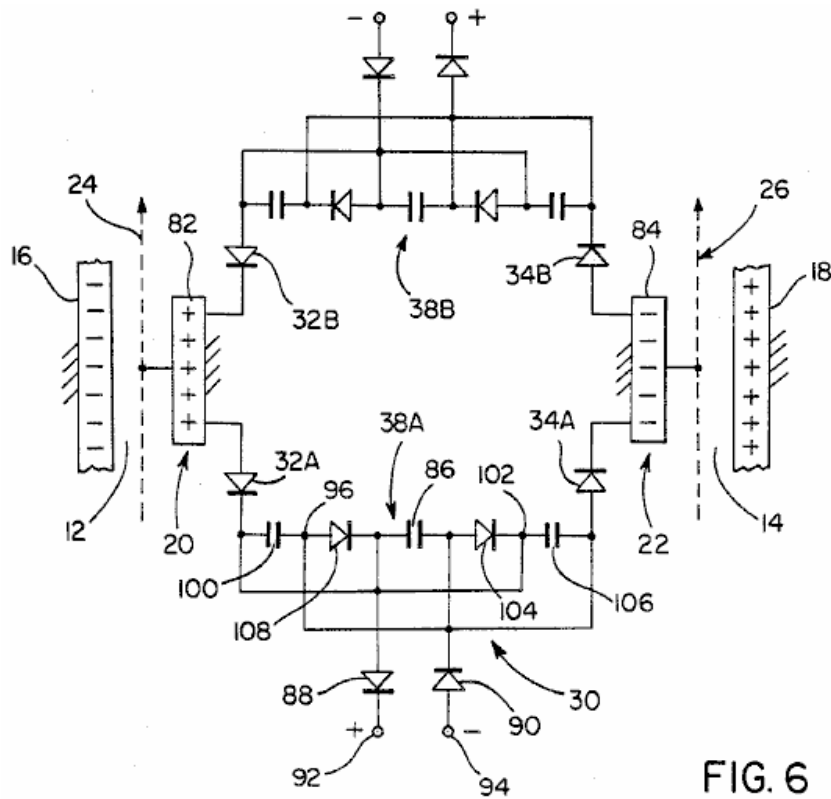

FIG. 6

According to the embodiment of the invention illustrated in **Fig.6**, the output circuit **30** includes the two oppositely poled capacitive circuit networks **38A** and **38B** connected across each aligned pair of stator segments **82** and **84** on the stators **20** and **22** by means of the oppositely poled diodes **32A** and **34A**. Each of these capacitive circuit networks includes a capacitor **86**, the opposite sides of which are connected by oppositely poled diodes **88** and **90** to positive and negative load terminals **92** and **94** across which a suitable electrical voltage is established for operating an electrical load. The diode **88** is connected to the junction **102** between diode **104** and one side of capacitor **106**. The diode **88** is also connected to the junction between one side of capacitor **100** and the diode **32A**. The diode **90**, on the other hand, is interconnected with the junction **96** between diode **108** and capacitor **100**. Also, diode **90** is connected to the junction between the other side of capacitor **106** and the diode **34A**. The foregoing circuit arrangement of capacitive network **38A** is the same as that of network **38B** by means of which aligned pairs of the stator segments **82** and **84** have the electrical potentials between them transformed into a lower voltage across the load terminals **92** and **94** to conduct a higher load current.

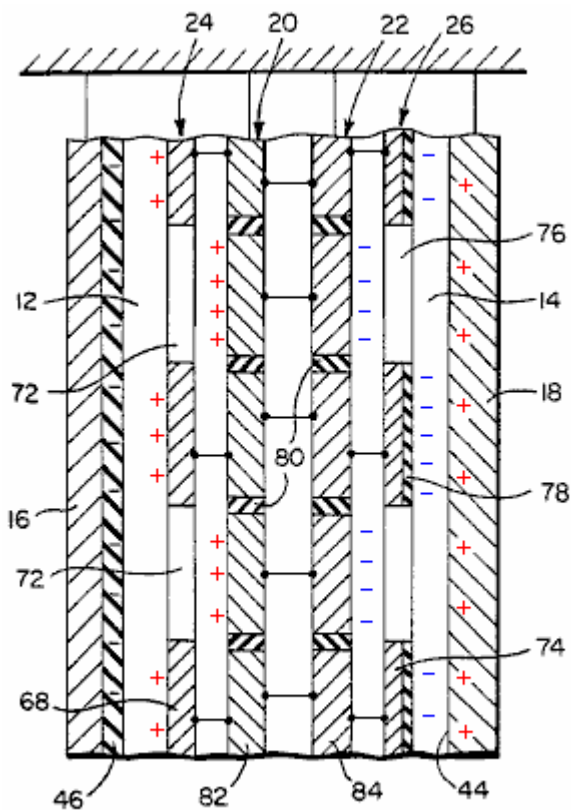

FIG. 5A

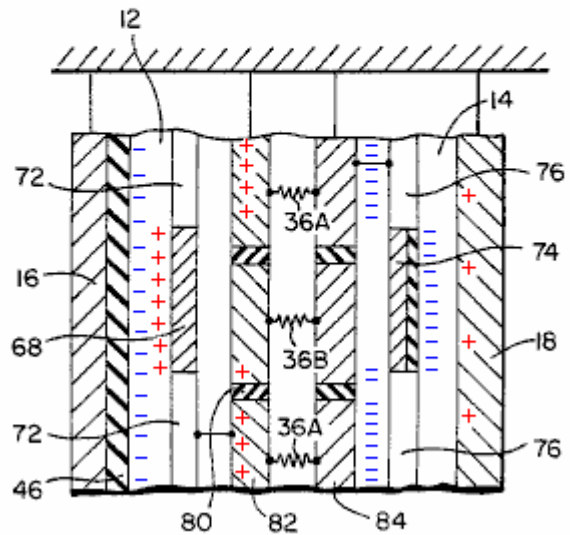

FIG. 5B

Fig.5A illustrates the distribution of charges established in the electric fields **12** and **14** between the electrodes and stators under static conditions in which each of the rotor segments **68** and **74** are positioned in alignment with one of the stator segments **82** and **84** to thereby shield alternate stator segments from the electric fields. The charges established by the electric fields are therefore confined to the faces of alternate stator segments confronting the electrodes and are equalised with the charges established on and confined to the shielding faces of the rotor segments confronting the electrodes by virtue of the electrical interconnection between the rotors and stators as already mentioned. As depicted in **Fig.5B**, when the rotors are rotated, the charge linkages established by the electric fields between the electrodes and alternate stator segments **82** or **84** are interrupted by the moving rotor segments **68** or **74** so that previously shielded stator segments become exposed to the fields to re-establish field energy linkages with the associated electrodes. Such action causes electrical potentials to be established between the stator segments **82** and **84**.

It will be apparent from the foregoing description that the electrostatic energy fields **12** and **14** of opposite polarity are established maintained between the externally charged electrodes **16** and **18** and the internally charged stators **20** and **22** under static conditions as depicted in **Fig.5A**. During rotation, the rotors **24** and **26** continuously positioned within the energy fields **12** and **14**, exert forces in directions perpendicular to the field flux representing the energy linkages between electrodes and stators to cause interruptions and reestablishment of energy linkages with portions of different stator segments as depicted in **Fig.5B**. Such energy linkage locational changes and the charge binding and unbinding actions between electrodes and stators creates an electrical potential and current to flow between stators through the output circuit **30**. Thus, the output circuit when loaded extracts energy from the electric fields **12** and **14** as a result of the field linkage charge binding and unbinding actions induced by rotation of the rotors. The stator segments **82** and **84** shielded from the electric fields by the moving rotor segments **68** and **74** as depicted in **Fig.5B**, have electric potentials of polarity opposite to those of the external electrodes **16** and **18** because of the field linkage charge unbinding action. Previously shielded stator segments being exposed to the electric fields by the moving rotor segments, have the same electric potential polarity as those of the external electrodes because of field linkage binding action. Since the forces exerted on the respective rotors by the electric fields **12** and **14** of opposite polarity act on the common rotor shaft assembly perpendicular to these fields, such forces cancel each other. The energy input to the system may therefore be substantially limited to mechanical bearing losses and windage during conversion of electrostatic field energy to electrical energy as well as electrical resistance losses and other electrical losses encountered in the output circuit **30**.

Based upon the foregoing operational characteristics, rotation of the rotors in accordance with the present

invention does not perform any substantial work against the external electric fields **12** and **14** since there is no net change in capacitance thereby enabling the system to convert energy with a reduced input of mechanical energy and high efficiency, as evidenced by minimal loss of charge on the electrodes. It was therefore found that working embodiments of the present invention require less than ten percent of the electrical output energy for the mechanical input. Further, according to one prototype model of the invention, a relatively high output voltage of 300,000 volts was obtained across the stators. By reason of such high voltage, an output circuit **30** having a voltage reducing and current multiplying attribute as already described, was selected so as to render the system suitable for many practical applications.

The Suppression of Knowledge.

Early in October 2011, Sir Christopher Woodhead, former Chief Inspector of Schools in England, stated that children should leave school at age 14 and become apprentices. While I personally have a high opinion of apprenticeships for certain professions, this appears to me to be a direct attempt to lower the education levels of the UK population even further than it already is now, where many sales staff are unable to perform even the most basic arithmetic as part of their jobs.

The basis for how we live our lives and understand the things around us, society, personal relationships, family values and the like, is rooted in what we are told by "the authorities". Unfortunately, much of what you have been told is just not true. You have been lied to about science, astronomy, the environment, global warming, government, taxation, war, energy, inventions, education, terrorism, health, finance and the media, to name just a few topics which spring to mind.

Science: There has been, and still is, systematic, deliberate, and frequently brutal suppression of scientific fact. We are being told that you have to "burn a fuel" in order to produce power which is then "consumed" when we use it to power our lives. This is a deliberate lie. We are told "scientific" things which are sheer fantasy and designed to keep the truth from us. The objective is to keep the people of this planet ignorant, weak, and subject to the people who know the real facts, and to remove all possible wealth from the ordinary person.

Astronomy: We are told that the only way we can get into space is to use rockets. The people who say this not only know it is a lie, but they themselves have had electrogravitic drive vehicles for at least fifty years now. This sort of rubbish is roughly the equivalent of telling people that they can only get around by hopping on one foot. We are told that the speed of light is a constant and that is a lie. We are told that nothing can go faster than the speed of light, and that is a lie. We are told that gravity depends on mass, and that is a lie. We are told that the Earth is the only planet in our solar system which has an atmosphere, and that is a lie. In fact, almost all of what we are told is incorrect.

The Environment: We are told that we need to run our lives by burning "fossil fuels" which are limited in quantity and so there is "an energy crisis". While some oil is produced by the decay of organisms and vegetation laid down in earlier eras, oil wells which were pumped supposedly dry are actually filling up again with oil created in the crust of the Earth and which does not come from decaying vegetation and organisms. Nor is there the slightest need to burn oil for power, or have central power stations and fragile wires running all over the countryside. Those things are wanted by the powerful elite in order to control ordinary people and to part them from their money.

Global Warming: We are told that man's burning of fossil fuels is causing global warming through the production of Carbon Dioxide. This is the most ridiculous rubbish possible. Carbon dioxide is a natural gas, essential for plant growth, which in turn is essential for our survival. Carbon dioxide levels have long since reached the level where any increase has almost no further effect on warming. The percentage produced by man is trivial, as the vast majority comes out of volcanoes, the next largest amount is produced by animals and insects, and man's contribution is minor. Global warming and global cooling are natural events which were taking place long before man was around in any significant numbers and certainly, centuries before the burning of fossil fuels started. The contribution from all of the cars in all of the world is only about 1.7% of man's minor contribution and the fussing about "carbon footprint" is only a con which is being used to extract more money from the ordinary person.

David Archibald in this document http://www.davidarchibald.info/papers/Climate_Outlook_to_2030.pdf, published the graph shown here in 2006:

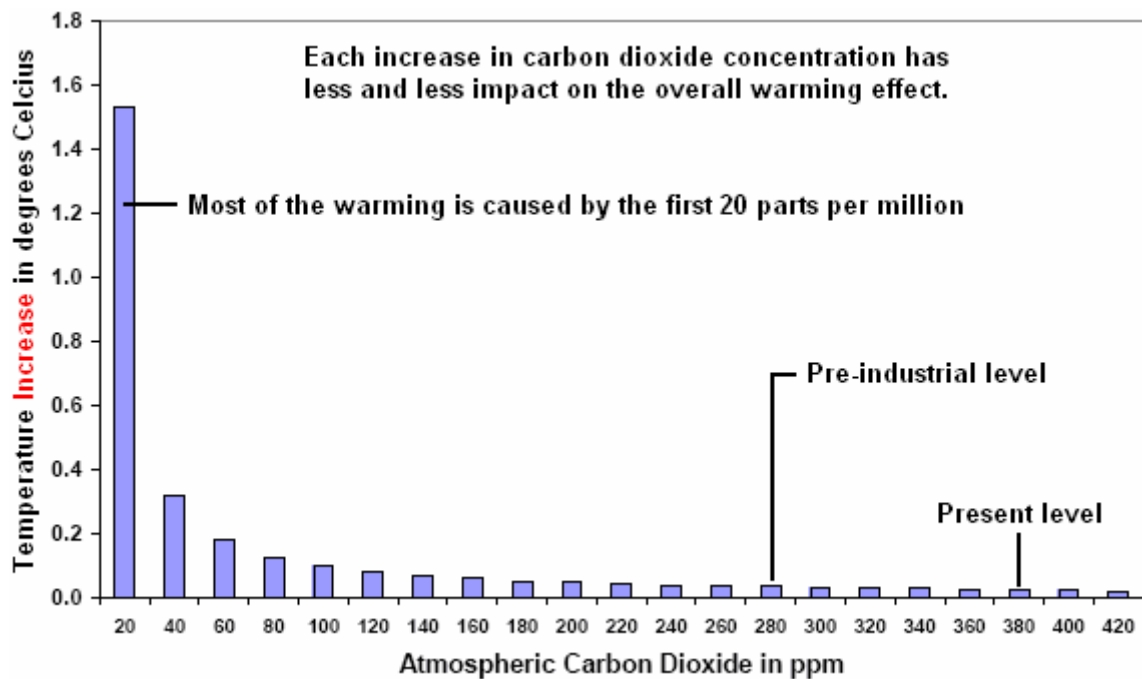

This graph clearly shows that even a big increase in the present carbon dioxide level has almost no impact on atmospheric temperature. It has also been calculated that an increase to 620 ppm would give a temperature increase of only 0.16°C. The graph shown above, together with its calculations should have ended any further discussion about reducing carbon dioxide emissions. However, this has most definitely not been the case.

For financial reasons, a decision has apparently been taken to keep up the pressure on carbon dioxide reductions, resulting in senseless investments on new technology for capture and storing carbon dioxide, “beautiful” windmills absolutely everywhere and the mandatory use of bio fuel (which has a negative impact on food production). Don’t forget about all the revenue which ‘governments’ are getting from “climate taxes”.

All these taxes and the massive spending of taxpayers money, really threatens the economic foundations of the whole of the western world, but worse still are the consequences of the commitment to bio fuel. This mad strategy has caused a near doubling of the cost of cooking oil and essential foods such as rice, because farmland is now being used for the production of bio fuel. These increases are hitting poor countries the worst as the people can no longer afford to pay for basic necessities.

If the intention of the IPPC and the world’s politicians is to starve people to death, then they are definitely on the right track through their continued insistence on the supposedly harmful effects of carbon dioxide. In reality, the greenhouse gas which has the most effect is actually water vapour which accounts for about 98% of all warming. I wonder how the politicians are going to prevent water vapour from getting into our atmosphere !

In his video “An Inconvenient Truth” Al Gore points out the close correlation between the fluctuations of global temperatures and the levels of carbon dioxide in the atmosphere. He point out strong rises and falls in the average global temperature (nearly all of which are before mankind started burning oil) and the related strong rises and falls of carbon dioxide concentration in the air. What he is very careful to avoid mentioning is that the changes in carbon dioxide concentration, lag behind the global temperature changes by some 600 years. The carbon dioxide concentrations are a **result of** the global warming and **not** the cause of it.

Government and Taxation: It appears that the sole purpose of government is to enrich the people in power at the expense of the ordinary person. People in a democracy are supposed to be “free” but this is a gross illusion. If you were working all week in a company and at the end of the week you were paid £1,000 cash. When you start going home, an armed gang of thugs threatens you and steals £800 of your £1,000 and that happens every week without fail. So, what do you think of that arrangement? Good or bad? That is what government does for you at this time. But, you say, “we live in a democracy, so we can fire the politicians”. That is the equivalent of having three exits from your workplace and each exit has a different gang of thugs ready to rob you. Yes, indeed, you have choice. You can choose which exit to use and therefore, which particular gang of thugs robs you.

You think that is overstating the case? I have seen it calculated that 80% of everything you earn is taken away from you in “taxes” and there is justification for that figure when you consider what contributes to the cost of everything you do. You pay taxes. Can you remember being asked if you would be willing to pay tax?

Oh, but you say, we need taxes in order to pay for public services, health, education, transport, etc. Yes we do, but how much of your money actually goes on that. In the UK there is a large annual “car tax” which was introduced with the excuse that it was needed to finance the building and repair of roads. I understand that at least 85% of that money is not spent on the roads. There is a massive tax on vehicle fuel and I have seen the figure of 85% mentioned. If that is the case, fuel should only be one sixth of the price charged and that extra cost finds it’s way into almost everything else, food, clothes, electrical goods, all manufactured items, heating, electricity supply, gas supply, etc. etc. In addition, there are major taxes on alcohol, tobacco, service industries, travel, and everything else that ‘politicians’ can think up. So you’re a free person living in a free democracy? Who are you kidding? Do you actually have “sucker” stamped on your forehead? For further information, visit <http://www.yourstrawman.com> where the facts are laid out clearly.

Take the case of America. The objective of the Civil War was to make money for the unscrupulous. A really major fraud was perpetrated on the American people at that time. They believed (and most still do) that the United States is the government of the American nation. That is not the case. “The United States of America” is actually a commercial conglomerate of private corporations, corporations with names like “The State of Arizona”, or, “The State of Texas”. Federal taxes are imposed on the American people, but that goes directly into the private finances of these companies and not a single dollar of it goes to benefit any ordinary American citizen. There is much more detail on this in Chapter 15.

War: The general public is held subject to what passes for ‘government’ through fear and ignorance. The government announces that some country needs to be attacked and invaded in order to “free” the people and establish democracy. So, generally without any realistic reason, that country is attacked and invaded, much of the civilian population killed, massive property damage inflicted, and great distress and hardship caused for many people. This is organised by the politicians. Do they themselves take part in the fighting? No. Who benefits from the war? Answer: the arms manufacturers, and companies such as Halliburton which are paid taxation money to rebuild what the local army has just spent time destroying. The country attacked is likely to have it’s assets stolen and then be saddled with a massive fake debt so that it can be forced to pay incredible amounts of “interest” for decades afterwards. The lucky country has been attacked, damaged, citizens killed, infrastructure destroyed, assets stolen and then robbed for years afterwards by the people who caused that devastation. You did say that you live in “a free democracy”, didn’t you?

Energy: The energy companies are very keen to sell you fuel for you to burn to “get” energy to run your vehicles, home appliances, heating, etc. They are also very keen that you should not discover that you are surrounded by energy which can be used for all those things without paying the local energy company anything. Most people imagine that the electrical power which flows out of the wall socket in your home (and for which you have to pay a good deal), comes along the wires from the generator station which burns fossil fuel to drive the generators. That is not the case, as not a single electron of the current you use actually comes from the power station but instead is collected locally from free environmental energy. If you knew how to do it, then you would have no need for the power company, power lines across the country, power stations or oil drilling and shipment around the world. Cars don’t need fuel to run but that information is heavily suppressed and you are lied to when you are told that you need to burn a fuel to power your life.

Inventions: When they discover that there is such a thing as free-energy, most people think that what is needed is a scientific breakthrough in order to develop the technology needed to let everyone have free energy. The reality is quite the reverse as the technology has been discovered and implemented literally thousands of times. You are being lied to when you are told that free-energy is “impossible”. I am reliably informed that in America alone, more than 40,000 free-energy patents have been confiscated by the (private company called the) Patent Office. Inventors are then silenced by a gag order under the absurd excuse that the invention is “of National Security importance”. Inventors who don’t try to patent their inventions are intimidated, some are murdered, some are attacked and their reputation smeared, some are illegally put in mental institutions, some are framed and all suffer massive financial opposition if they try to start manufacturing a product for sale – not even Cal-Tech managed to get past that financial block. I personally know several researchers who have been unlawfully intimidated.

Education: There is a massive program of “dumbing-down” education combined with the deliberate teaching of things which are known to be completely wrong. After only a few decades of this, many adults can’t perform basic arithmetic or construct simple sentences in their native tongue. Science and Engineering are neglected and most people don’t understand how things work. Most schools no longer allow

schoolchildren to perform experiments in chemistry or physics, usually with the excuse that it is 'too dangerous'. University students are told that there is no such thing as perpetual motion, which is as laughable as saying that water isn't wet. Newton actually said that gravity is a push and not a pulling force as indicated by the mis-translation of his Latin original text. This incorrect notion of gravity is still taught in spite of the fact that many governments have had electrogravitic drive vehicles since the early 1960s, driven by electromagnetic waves just below the frequency of infrared, disproving what is supposed to be Newton's theory, in a most resounding fashion. Any academic who steps out of line and admits that students are being taught rubbish, is immediately attacked with every possible means to discredit, ridicule and isolate him. The objective in all of this is to manoeuvre the general public into a weak position where they are ignorant, uneducated, fed false information and distracted with things of no importance. The ultimate aim is the slavery of the masses without them even realising that they are being enslaved.

Terrorism: The main way to make people give up their rights and do whatever you want is through fear. The book "1984" (dated that way because it was written in 1948) explains how this is done. Fictitious enemies are invented in order to frighten people and stop them complaining when vast amounts of their money is given to vested interests under the guise of being steps to protect them from this imagined danger. The "cold war" was completely fake with both sides using it as an excuse. The invasion of smaller countries is never, ever, for the reason given publicly, but is always for financial gain by the people in power and their commercial colleagues. The reasons given for these invasions are so ridiculous that it never ceases to amaze me that the public actually accept and believe these wild stories. One of the strands of this continuous deception waged against the public is fake "terrorism", frequently bolstered up by "false flag" attacks to discredit the perfectly innocent people who are supposed to have made those attacks. Any real terrorist attacks are normally a response to atrocities committed against the supposed "terrorists". The commercial companies which pass for governments, are the biggest terrorists around.

Health: The pharmaceuticals industry is one of the biggest money-making operations on the planet. It may come as a shock to you, but they don't want to cure people. Instead, they want people to go on buying expensive medication at heavily inflated prices. Long term health treatments are their ideal situation as that provides them with a continuous revenue stream. Several people have come up with very effective cures for cancer and other serious illnesses, and those people have received the same unjustifiable, outrageous treatment as do the inventors of free-energy devices. The pharmaceuticals industry is well aware of the highly beneficial effects of colloidal silver, but they will never produce any as they can't patent it and charge highly inflated prices for it. Consequently, they are not interested as their only objective is to make money, and it is definitely not to cure people.

Bob Beck's Electronic Pulsar.

The late Bob Beck emphasised this in his video lecture which may still be available at:

http://video.google.com/videoplay?docid=-3383948315844437935&ei=XdqBSruckK5_sqAPr28irBg&q=Suppressed+Medical+Discovery%3A+Dr.+Robert+C.+Beck+%28+Cancer%2CAIDS%2C+anything+viral%29#

Here is an excerpt from that lecture:

For the last five years I have spent my own money (no government or university funding) in investigating a thing which has proven to be the most remarkable thing for all diseases that I have ever heard of personally, and I have been in this field for about forty years.

I have a stack of IRB Studies – PCR laboratory reports from major hospitals around the United States, and until these are peer-reviewed published, I am not supposed to show them to anyone who is not a medical doctor because of patient confidentiality.



Now, how many of you have read that there is no cure for AIDS? That is an absolute lie. There has been a perfectly workable, 95% accurate cure for HIV and cancer and herpes and hepatitis and Epstein-Barr and about a dozen other incurable diseases, which was invented on March 11th 1990 at the Albert Einstein College of Medicine in New York City by Drs Kelly and Wymans.

And what happened to this breakthrough which is far more important than penicillin, antibiotics, anything you can name? - it has been suppressed. And why has this information been withheld from you – information which you can easily prove for yourself (don't take my word here for anything: check it out)? I found recently that the Mafia owns about 51% of major pharmaceutical houses as well as working the other side of the track with the *illegal* drugs from South and Central America and China.

The medical cartels in this country (USA) will charge you from \$50,000 to \$200,000 if you have terminal

cancer and this is for surgery and chemotherapy and radiation and hospital care.

Consider a packet of Wrigley's Spearmint chewing gum. That packet of chewing gum cost me a nickel (5 cents or \$0.05) when I was a young man and I paid \$1.32 for that packet at the Chicago Airport recently - \$1.00 for the gum plus \$0.32 for taxes and handling. The price of that package of chewing gum is every penny (cent) that it takes to cure [and I'm not supposed to use this word as only a doctor may use the word 'cure'] most of the known diseases in America today. And why haven't you heard about this? – because General Electric, Westinghouse, and the other companies have billions of dollars tied up in X-rays, CAT scanners and MRIs which are leased to health organisations, and for \$1.32 you can cure yourself without doctors, without pharmaceuticals, without medicines, certainly without surgery, certainly without chemotherapy, without any drugs, without any herbs, any homeopathy remedies – you can do it for yourself and it has been done.

People keep asking “why haven't I heard about this, why are there no hospital studies?”. There are hundreds of them. Here is one test result: At this date, the eleventh of August 1998 this patient had only about 3,063 particles of HIV in his blood. But now, as this test develops, the PCR on the third of November 1998, (several months later), the count was less than 1 in a hundred, which means that the test result was zero as far as this test was concerned. We have a stack of these reports a foot and a half (45 cm) deep, where **every one** of these full-blown AIDS patients, every one even though some of them were on life-support systems or needed attendants to lift them from the bed, these people are symptom-free now. Every single one of them is back at work. Not one of them has the symptoms of AIDS. So, if you read in your newspaper ‘the proceeds of the baseball game this Saturday will be donated to a search for a cure for AIDS’ that is an absolute lie.

There is, and has been, a cure for AIDS – **all** AIDS – a cure for about 95% of cancer, a 100% cure for Epstein-Barr, hepatitis, lupus, about a 50% cure for herpes, and I've been funding these out of my own pocket. I have absolutely nothing whatsoever for sale. God has been exceedingly good to me – I think that I am going about my Father's business here, and I am paying for it myself and I am giving to the world.

There is a free paper available entitled “Take Back Your Power” (a web download link for this is <http://www.free-energy-info.tuks.nl/Beck.pdf>) you do not need doctors, nurses, chiropractors, herbs, pharmaceuticals, surgery. Only if you are going along with the politically-correct solutions do you need these things that your neighbours have been depending on for all these many generations. There was paper entitled “Blood Electrification and Immune System Restoration with Microcurrents – A Proven, Startling, Rapid, Inexpensive and Safe Discovery for Positive, Controllable Remissions”. Now we found that this information has been suppressed. The doctors who discovered this, and let me tell you about the discovery: In 1990, they put a couple of small platinum wires into a Petrie dish that contained highly infected human blood, and the infection there was a very, very strong dose of HIV which was supposedly the cause of AIDS. They found that when they had electrified this blood, the HIV could no longer attach to any receptor sites in the blood. That means that the healthy cells could not be infected by the HIV. The only mention of this incredible discovery was in *Science News* March 30th 1991, page 207, ‘*Shocking Treatment Proposed for AIDS*’ and it tells about how these two doctors had given a paper on this process saying, ‘the experiments described on March 14th at Washington DC at the first International Symposium on Combination Therapies, showed that the shocked viruses lost the ability to make an enzyme crucial for their reproduction and could no longer cause the white cells to clump together – the true key signs of viral infection.

The only papers which I was able to find that got into the American press were *Science News* and article in *Longevity News* ‘*Electrocuting the AIDS Virus*’. But what happened in the *Longevity* article (which was December 1992, page 14), was that Dr Colley said ‘it will be 15 years before this process is ready for human experimentation’.

We have been doing it, sub-rosa, with patient consent, for over five years here, and we have the test results to prove it. When I was lecturing to a room of about 800 people, an 80-year old man came up and said ‘Bob, I was sent home today, my cancer had metastasised all through my system. I was told to go home and make my will, as I had at the most, about two or three weeks to live. I went home and I made my will and I saw your article in some magazine and I did it. I am now free of all cancer. My biopsies are clean, my CAT scans are clean. I went back to work, and being an attorney, I had to work sixteen hours per day to catch up on all the work I had missed while I was in intensive care. Now I'm jogging three miles per day’ (and there were tears running down his face).

We have had women who have had lupus for about ten years, barely able to make it from the couch in front of the television to the bedroom. They are back at the malls now, spending their money, walking around and able to hold jobs full-time. Do any of you know Linda Wright ? She brought in a clean blood test one day

and said 'my doctor had to send this to two different labs – he's never seen a person with clean blood after that person has had lupus'.

We have dozens of these people, and not one of these people went to the doctor for the cure, except for the people who are on this Institutional Review Board study at a hospital in Huntington Beach and Newport Beach, California. Now, the point is, in my humble opinion, and we can put anything against this because we know that it is true at this time, when I first started this I thought 'this is kind of interesting'. I have looked into five hundred things that never worked, the Rife Machine never worked, Holderclarke's Machine does not work, many, many, many of these devices work only marginally, and I felt 'I'm about to be taken in again', I have built Mucalsky multiple-wave oscillators as you know. I have built almost every electro-medical device since I've been in California (since World War Two began), and these things worked at best, marginally. But the thing which you can build for yourself, there is nothing that you have to buy. The circuit diagram and all of the instructions for building this, are in the paper. This is the one which I designed in 1991 to make an experimental study with, and you can get a kit from an electronics store. I get not one nickel from the tens of thousands of dollars worth of these kits which they have sold.

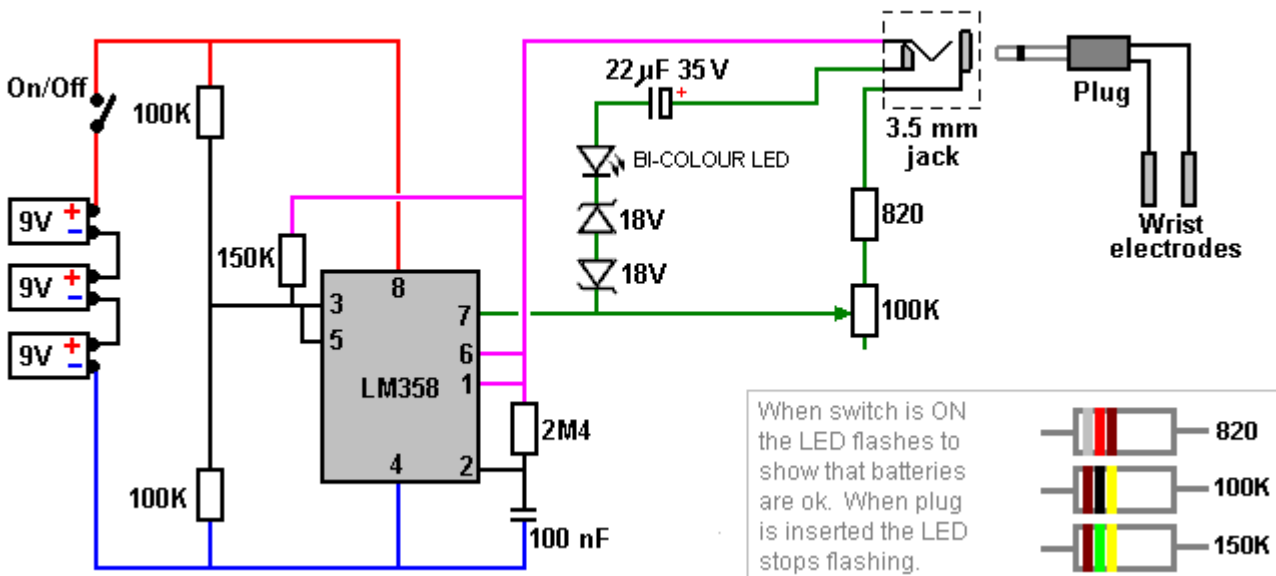
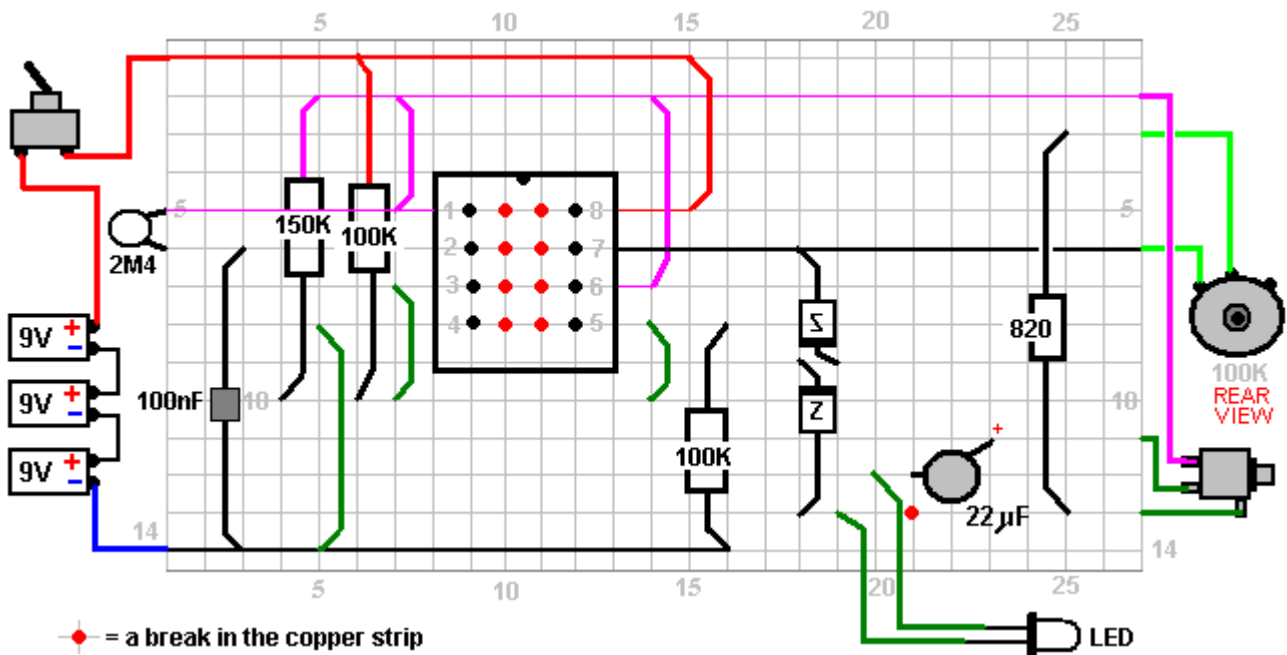

There is a parts list on page 4 that tells you what is needed. Even if you don't know what a resistor is, or a capacitor is, put the list on the counter at Radio Shack and tell them to give you what is on the list. The retail price ready-made is around \$150. If you build it yourself it will cost \$15 to \$20 and this machine will not only make colloids, which is the most powerful medicine known to man, (which is why the FDA has stamped it out recently).

SOTA Instruments Inc. Canada (1-800-224-0242) builds these devices because the owner read the article in PACE magazine and his wife had chronic fatigue syndrome and Epstein-Barr so badly that she was non-functional. She is now up and around and is totally well today because my husband built this little box for about \$15. The box straps on the arm with the electrodes positioned on the radial and ulna arteries and puts a very small electrification into the body which removes **all** parasites, viruses, fungus, microbes, pathogens – everything in the blood which does not belong there and was not there the day that you were born, eventually (after two or three weeks) being neutralised and discarded by your body, dead or alive by the spleen, the kidneys and the liver. This is darned exciting but when the hospitals tried to patent this, US Patent 5,188,738 presented to Dr Colley on February 23rd 1993, describes the process, as do fourteen other patents from Harvard MIT, page 1 column 1 says ‘because of this problem (the fact that there is no known antibiotic or vaccine for any of these incurable diseases) the present invention has been devised to attenuate any bacteria, virus (including the AIDS HIV virus), parasites and fungus contained in blood contributed by a donor, these being rendered ineffective for infecting a normally healthy human cell’. Before these claims were accepted by the patent examiners, they had to provide the examiners with massive proof.

Now there has been a cure, a known cure and it costs \$1.32 per patient so there is no money in this if they are trying to sell you combination therapies for \$20,000 to \$60,000 per year.

I strongly recommend that you get the paper as it contains the exact electrode locations which have been found to work the best and get the maximum current into the blood. It is almost as if God the Creator had locked the back door approach to the problems and with an adversary like the Holy Spirit which is within – the Bible says ‘look within, not without’. And this time, the adversary is within. The ‘aliens’ in your blood are the things which are holding down your lifespan to seventy or eighty years. Many, many generations ago, according to the sacred texts, they lived to be several hundred years old, Solomon, David, Methuselah, etc.

So, we have raided about a dozen different medical textbooks including Grey’s *Anatomy*, and we’ve published the exact spots where you can access the lymph tissue where these germs are going to be hibernating. After you clear yourself and get a clean bill of health, after three to five years you will re-infect yourself when many of these viruses which are latent, start germinating. And with this information, and these circuit diagrams and these instructions, we have literally given you back to yourself.

We are going to show you all of this before I leave here. This is not my opinion any more, we have enough proof that it is a statement of fact and we can bank on it. If you are too lazy, too stupid, too electronically impaired or too frightened to build your own, there are forty known companies (and probably a hundred that I know nothing about) that are building these things full-time and they are getting the most remarkable reports back. I do meet these people, and NO, I do not get a nickel from any single one of these companies, and all of this information is in your paper.

Now what else do we have to watch for here. Nobody has ever to this day died of AIDS. Did you know that? They have died of the opportunistic infections, pneumonia, Carkinson’s sarcoma, etc. etc. that can attack and ruin your body when your immune system cannot handle the load, in fact it is called ‘**HIV**’ (**H**uman **I**mmune-deficiency **V**irus) ‘**AIDS**’ is **A**cquired **I**mmune **D**eficiency **S**yndrome. Now this is the only way that I know of, I know the people who have written the books on ozone therapy, I won’t mention their names, I know the doctors who are using all of the herbs and drugs. I have talked to the people who worked with Dr David Ho who was on last week’s *Time* magazine cover as the Scientist of the Year, who has discovered that if you use two or three chemotherapy agents at the same time, you have a cocktail effect and it reduces the HIV count, the PCR count in the blood tediously. But what he didn’t tell you, and I think I’ll read this which was in *The Los Angeles Times* December 10th 1996: “Drug combo knocks HIV down, not out”. And a basic thing happened, they took some of these patients who were on combination therapy, which incidentally cost \$20,000 to \$60,000 per year, as soon as they stopped taking these cocktails, they got immensely elevated counts up in the millions or billions of AIDS counts, as though these chemotherapy agents, (AZT, DDI, DD5, etc.) had held this viral load down in the blood as long as they were taking it. The minute they stopped, it rebounded and many of the people were critically ill and they had to put them back on it immediately.

So, once you start on this cocktail therapy, you are stuck with it for life, as long as you live, and as you know from the International AIDS Conference in Japan last year, they found that none of these AZTs etc. prolonged the life of one single AIDS patient by even one day. Their’s is simply a promise, they are engineered to get your money while they give you hope. I was beaten up and bloodied; I was hit over the head and had blood running down my face, by ‘AIDS Act Up’ David Buller it was that was running this crusade in New York city in February. He called the New Yorker Hotel and said that they would burn down the hotel, so they gave me a bodyguard (who wasn’t around there all the time) and said ‘Bob, do not use the

front door but go around the back and use the service entrance – never go out the front door of this hotel. The last day when I was there and I had to run out to get a shuttle to take me to the New Jersey airport to bring me home, there was a guy standing across the street with a video camera and a guy who hit me over the head and bloodied me, and I didn't chase him down the street because my knees aren't very good as I don't have any cartilage in them.

But when's the last time that you saw me Ivan – about three years, four years ago? Do you notice anything that's different? I lost 130 pounds – I weighed 290 and I have pictures of me to prove it. My hair on top was thinner than some of my old good buddies here. As soon as I got rid of the adversaries – the aliens in my blood, my immune system took over and I got rid of the half a pound or so of parasites which every man, women and child in America (if he's more than four days old) is carrying. A new-born baby, after four hours has breathed enough air to become infected. If you live in America, there are 140 **known** indigenous parasites. If you live in Africa or the tropics, there are 500 identified and known parasites and probably half as many again that are unknown. When we got these parasites out of my body by wearing this device on my wrist, an amazing thing happened. I began losing weight like crazy. I thought 'my God, have I got stomach cancer or am I wasting away with something?'. No, I was in better shape than I was before I started.

This is a theory: about 30% of the parasites which live in human beings, and these can range from fourteen feet (4.27 m) long if they are a tape-worm down to microscopic size (which is why they have to use microscopes to do the stool analysis if you go in for a check), these parasites were setting my appetite. If you will think about this for a minute, it is not what you eat or how much you eat that has anything whatsoever to do with your weight. It is how much of what you eat you store as fat because the parasites have changed the P51, the leptin and about five or six known neuro-transmitters in the hypothalamus to feed them tomorrow. Many of these parasites have co-existed with mammals – apes, elephants for twenty million years and the anthropologists will tell you that they find them whenever they find a carcass frozen in the ice floes, these things have had parasites for as long as ever man has been on the planet. These parasites have learned to use you as a meal and not kill you because then they are going to die themselves, like ebola which runs its course in a couple of weeks. Many of these viruses do that, but these parasites almost kill you and use you for a meal in the same way that we send cattle to a feed loft before we take them to market. And when these parasites vanished from my body, and this is provable by dark-field microscopy, phase-contrast microscopy, any doctor who does this analysis can prove it, you don't have to take my word for it, I lost all of that weight and before this time I had offered \$10,000 cash currency 'under the table' to anyone who could get this weight off of me.

I had tried dozens of diet plans. I had tried these canned-meal Jenny Craig type adventures. I had been injected with pregnant mare's urine. I know that some of you have been through the same things. I had taken legal amphetamines to control my appetite ... I had tried everything until I had nearly killed myself. And until I found the true cause of what I believe is about 30% of the people who are overweight, and this was certainly me, I was terribly embarrassed to find the airline stewardess running down the aisle with a seat-belt extender because the seat-belt wouldn't fit around me. I couldn't sit in the booth in a restaurant because I'd have to sit on a chair, etc. etc.

The lady at the back of the room, Jane had inoperable cancer when I met her. She said "I'm going along with blood-cleansing here, and not the chemotherapy and radiation which the doctor had said that if I do not have I will surely die". And her daughter Cathy was outraged because her mother didn't do all of this chemotherapy and have her hair drop out ... Now she is totally well. Her last several physicals – biopsies and CAT scans – have shown not one speck of cancer anywhere in her body. Neither have dozens and dozens of 'terminal' cancer patients.

Now, why does this work for cancer? We started out working with viral and microbe and parasitic diseases. When oncologists in the East began reporting many, many, many cancer cures, we had to have a telephone conference between about four or five of us. Now what's really happening here? I don't believe it until I see the medical proof. So I guess you know that about three months ago *Explorer* magazine published an article entitled '*Total Cancer Remissions through Blood Electrification combined with Silver Colloid*'. And this article of two pages is reprinted in its entirety in the paper which you should be taking home with you.

Social Security does not want you to live if you get to be 65. I'm now way past that. I don't act like it, but I am way past that, I'm in my seventies. The Director of Social Security – I will not mention his name because he picks me up at the airport when I'm in Washington and drives me where I'm going – I've stayed in his house – says 'Bob, we want anyone who reaches 65 to be stored like cord-wood in an old-age home and given mind-control drugs like valium and let him die because Social Security is bankrupt **now**, it won't be *bankrupt in five years time* as it is bankrupt now. And if you restore perfect health to these people with a device that will fit in your shirt pocket, the job market will not absorb the people getting out of college today.

Even if McDonalds has a smart cash register, they can't add or subtract, they can hardly write a paragraph and you want to get these experienced people back in the jobs market?'. I said 'hell yes!' I was 65 nearly ten years ago.

Another problem: this steps on the toes of all the vested interests. They are expecting to make hundreds of thousands of dollars off of you: Health Management organisations, insurance companies, hospitals, ... If you own a boat that thing is written into the budget of the boat builder down there in San Pedro. These medical people expect to see you come in there some day and spend a lot of money, but if you do this for yourself, you will get well. There are seventeen of us who I know of, and I know sixteen of them personally, who this day have immortal blood. Now this is a rather dramatic claim, so let me tell you what it means. Toward the end of last year, there was a dark-field microscopist 'Mike', you know his name, he is world famous, he's the fellow who trains doctors all over the world how to use this type of technology for diagnostic work. He invited a chap in who had been on one of these devices for about six months, and he said 'Let's look at your blood', so he pricked his finger, put that drop of blood in a microscope slide and looked at it. And he said 'you don't have any background clutter in your blood'. Of course, they couldn't see viruses as this was a light microscope with a magnification of about three thousand times, back-illuminated. He said 'just a minute – I must have done something wrong', so he stuck another finger, then he went to the earlobe and made a slide and said 'what have you been doing? anyone who has ever come to me, man, woman or child, in the last thirteen years, you can see the parasites, many of the germs, microbes and bacteria swimming around in the blood but you don't have any at all. The patient said that he had been on the blood cleaner so Dr Mike said 'give me some of those, I've got to test them on some of my patients – I don't believe you'. He did, and they worked.

Now, in Colorado, blood is considered 'toxic waste' or hazardous waste. It must be picked up and disposed of by incineration by registered toxic waste disposal people. Dr Mike had thrown these three or four slides in a box underneath his laboratory table. He looked down at this box about twenty-seven days afterwards and checked the slides again under the microscope. That blood was still alive. The half-life of human blood on an unsealed microscope slide is between two and a half to four days maximum. Twenty-seven days had gone by and the red cells were swimming in the plasma exactly the same as the minute he had drawn that blood. It had not crenated (serrated around the edge) – a fibrin reaction had not set in although it had evaporated around the edges. Now let's get to the point. One month after that, that is some fifty-one days later, those slides had not yet been picked up for disposal, so Mike checked them again. The blood had 'circled the wagons': there was about a half a millimetre spot in the middle where the cells had not evaporated and were still alive.

The people in his practice who had been tested upon with the blood cleansers have now got immortal blood. Now, what does this mean? If 'the adversary is within' he might not be a man with a red tail and horns out there somewhere with the number 666. Just as the Holy Spirit dwells within this temple, so might the adversary, at least the aliens which have been involved with us over many, many moons are in there and you can see them if you go to a dark-field microscopist, if you get rid of those, who knows what is going to happen? What happened to me. I was so fat that I was in a wheelchair and I had been given up for dead. The doctors who came to see me, friends of mine who were Medical Doctors who hadn't made a house call in Beverley Hills in thirty years, were coming down to my apartment saying 'Bob, you'd better dispose of whatever you've got – you'll never walk again. I was given so many tests. I brought Dr. Alexander Everett from Washington, paid his way, put him up in the *Red Lion* hotel. He worked on me until he said 'Bob, I'll have to go back now, there is nothing that anyone can do for you'. And I was in a wheelchair, but I'm sure as hell not dead! Everything is working well again.

My blood pressure when I started this averaged 219 over 190 and was borderline diabetic with blood sugar 425 to 475. Today my blood pressure is 130 to 140 over 70 to 75 and after just three weeks my blood sugar had dropped to 150, which at that time was considered normal.

So I'm here to share this information with you. I have nothing for sale. There are people who are selling things, I'm not one of them. Part of that is because I believe that God's work should be given freely. I expect to get my reward somewhere else if I don't come back to this planet of painful endeavour. I have a lot of theories about this and also the Food and Drugs Administration has come to my door with drawn guns at three o'clock in the morning. I have been beaten up by the people supporting the pharmaceutical houses who don't want a \$1.32 cure for AIDS.

Bob also speaks of his use of colloidal silver, (a document on which can be downloaded using the download link <http://www.free-energy-info.tuks.nl/Silver.pdf>) although Bob's method of production looks more simple. He says:

This is a glass of water which I got out of the kitchen. I've taken a single 9-volt battery and put a little "grain

of wheat” bulb (6 to 12 volt 55 milliamp) in series with the battery and these two silver wires. There is no known germ, bacteria or microbe which can survive what I am about to do right now. I'm going to put these two silver wires into this glass of water, about half an inch (12 mm) apart, and leave them there for about three minutes. That is all it takes. This is tap water and you can make this silver colloid for about one tenth of a cent per gallon and that is the most powerful medicine known to man. After three minutes Bob stirs the colloid with a plastic knife and demonstrates how a laser beam reflects off the microscopic particles of silver suspended in the water and then drinks the water. Bob drinks two or three glasses of colloid each day. The colloid prevents you from contract secondary infections during the first three weeks while you are getting well with the blood electrification process.

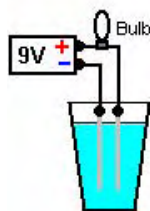

Finance: Money only has value when backed by something of worth. The largest purchase that most people make is buying a property. This is often done by taking out a mortgage with a financial institution such as a bank or a Building Society. For this, most people sign a mortgage agreement with the bank, agreeing to pay back the mortgage amount plus a large amount of interest, generally over a period of many years. If you default on the repayments, typically after many years of payments, the bank takes your property and sells it in order to gain as much money as they can. What you are not told is that the mortgage agreement is a contract and no contract is valid unless something of worth is offered by both parties and full disclosure of all circumstances is made. The bank does not offer anything of value as it just invents the money, creating it out of thin air and without any backing of something of worth. The bank regulations actually forbids the bank from lending out money deposited by it's members, so a bank cannot legally enter into any such mortgage agreement backed by the funds deposited with it. Further, no contract is valid unless there is a “wet ink” signature by both parties and a wet ink signature can only be made by a human. A bank cannot make a wet ink signature, nor can some other individual sign a contract on behalf of somebody else, so, no mortgage agreement is actually valid in law. Also, the bank being aware of this and not making it clear to you the mortgagee, is in breach of the “full disclosure” requirement of a contract, which is enough to invalidate the contract anyway. Therefore, if a bank tries to take your property for lack of payments, they are acting unlawfully and are not entitled to do so. They usually get away with it, because most people are not aware of the real facts involved.

The Media: You are expected to believe that the media is an honest and unbiased source of information. The reality is that all of the main media outlets are owned by just a few, very rich individuals, and their objective is **not** to provide unbiased reporting. It appears that they have three main objectives.

First, they want to make money and objective and truthful reporting does not necessarily help towards that goal. You will never, ever, find honest reporting of anything to do with free-energy or any other positive thing which individuals can do for themselves. For example, if a “report” is made on say, an HHO booster to improve mpg and reduce harmful emissions dramatically, it will be arranged that the supposed results show that these thing are not worthwhile. Contrast that with the reality that Dr Scott Cramton can use HHO gas from the electrolysis of water, to reduce the fuel requirement of any diesel engine by at least 60%. No matter how you try, no major news outlet will every report the honest facts as that could damage the excessive revenue stream of the oil companies.

Second, they want to generate as much fear and worry as possible because doing that over an extended period, causes the average person to be more amenable to having their freedoms taken away from them. It facilitates the introduction of surveillance on everybody, identity papers (birth certificate, driving licence, passport, social security number, voting register, National Census record, etc. – very much in the Nazi occupation style), going to war with countries which have never harmed you, considering people to be dishonourable just on the basis of their nationality, and the like. Try counting the items reported in the daily

news which are negative – murders, attacks, dishonesty, deaths through accidents, deaths through natural disasters, kidnappings, piracy, violence, environmental damage, etc. and compare that number to the count of positive things reported on – happy events, acts of kindness, successful ventures, etc. and see what ration you get, day after day, after day. This is not just sales being boosted because people love to read about disaster. Instead, it is a deliberate, long-term policy of psychological warfare against ordinary people.

Third, they deliberately divert the attention of people away from anything of real importance by promoting and encouraging excessive interest in things of no importance. There is a deliberate dumbing-down of almost all TV programs in the UK, the promotion of excessively violent video games, the promotion of trivia such as celebrities and their activities, dieting, gossip, fashion, and other irrelevant topics. They want you to give all of your attention to these things and not notice what is actually going on all around you.

Joseph Cater's Comments.

Joseph H. Cater has produced a book entitled "Ultimate Reality" which I find impossible to buy at any reasonable price level. In it, he points out many things which he supports with strong evidence. These things seem startling because, and only because, the present educational system deliberately encourages us to believe things which are clearly not true. Google books have a partial copy of the "The Ultimate Reality" at:

<http://books.google.com/books?id=ySsNiCPUecC&printsec=frontcover&dq=the+ultimate+reality+cater&cd=1#v=onepage&q&f=false>

The things which Joseph Cater states are so unusual that it would be easy to write him off as a crank. However, he backs up what he says, with a considerable body of realistic evidence which makes it very difficult to ignore what he says, in spite of the fact that most of his findings flatly contradict what we have been taught from an early age, and so accept as being reality. Whether or not you accept what he says is entirely up to you, but it is difficult for an honest person to reject his presentation out of hand.

He puts forward a strong case for there being a deliberate programme of scientific misinformation and suppression aimed at keeping the general public completely ignorant as to the actual physical realities of the solar system and the universe in general, and as a result, reality is very far from the popular conception. Mr Cater's description of matter provides reasoned explanations for a whole range of anomalies which conventional science can't adequately explain, and he quotes numerous experiments which provide firm evidence that what he is saying has a substantial basis in fact.

Here is a very brief summary of some of what he says in his book "The Ultimate Reality":

The biggest single factor is in the erroneous theory of sub-atomic particles. Mr Cater states that reality is actually much more simple than conventional theory suggests. The universe is filled with a range of energetic particles which he describes as "higher order ethers" and "lower order ethers". These ether particles are in continuous random movement at different frequencies and they produce a number of different kinds of composite particles including "Hard electrons" (with which we are already familiar) and "Soft electrons" which have very different properties. Soft electrons can draw hard electrons into themselves, masking the properties of those hard electrons. Combinations of ether particles form photons and all matter is composed of photons and these ether particles.

The operational forces which govern all matter in the universe are only electrostatic force and magnetic force, and the actions of both of these are modified by many different combinations of the two types of electron. As light is composed of photons and as they interact with the two types of electrons, many observed scientific facts have led to wholly incorrect deductions. Mr Cater indicates that the New World Order "elite" carefully foster and support these false conclusions, suppress information and physically alter observations before they reach the public. Mr Cater points out a number of instances where the alteration of data has not been sufficient to suppress the facts.

It is not possible to mention all of the points which Mr Cater makes, so please understand that the following is only a minor selection from a cohesive whole and much of the supporting evidence which he provides in his book is omitted here.

Mr Cater says:

1. The current theory of gravity is completely wrong, and gravity is caused by a component of the electromagnetic spectrum of about one trillion cycles per second (0.3 to 4.3 mm wavelength; located above

radar and below the infra-red region). The theory of gravity put forward by Sir Isaac Newton does not account for the **amount** of deflection of a plumb bob near a mountain. An asteroid as small as 150 miles in diameter, can have a surface gravity about the same as Earth's and some asteroids have moons of their own orbiting around them. This would be impossible if Newton was right.

As a result of the real cause of gravity, our Moon has a much higher surface gravity than was expected, (and consequently, a serious atmosphere). NASA had a major problem with the lunar landing of 1969 because if the real facts became known, then it would demonstrate that a major section of physics, as it is currently presented, is incorrect and they want to keep things exactly as they are at present. The Moon, in common with most planets, is not solid. When part of the lunar lander was dropped back on to the surface of the Moon, a seismic detector left on the surface showed that the Moon vibrated like a bell for about an hour afterwards. That would not have happened if the Moon were solid.

There is very clear evidence that NASA has censored the Moon landing very heavily, but their attempts at suppression have been flawed and some obvious pointers exist. For example, NASA claimed that the space suits of the astronauts weighed 185 lbs when on Earth. Photographs exist, showing an astronaut leaning over backwards and then regaining his balance. That would be a physical impossibility even under reduced gravity, and this implies that the "life support" systems were actually empty and not needed because there is an atmosphere. The high surface gravity is also seen when the astronauts ran. Even the slowed-down version released by NASA can't conceal the length of the steps and the height off the ground which are the same as they would be on Earth.

If the Moon had one sixth of the Earth's gravity as is claimed by conventional science, then the point at which the gravitational pull of the Earth balances that of the Moon would be about 22,000 miles from the Moon. The Encyclopaedia Britannica states this distance as being about 40,000 miles, which agrees with various other sources. That could only be so if the Moon's surface gravity were much higher than the supposed one sixth of Earth's gravity.

On more than one occasion, an Apollo astronaut tripped and fell on his face. Under one sixth gravity, that just would not happen, especially with a fit and active astronaut. Also, the rover vehicle used in later landings was 10' long, 7.5' wide and 4' high with 32-inch diameter wheels. The Earth weight was 460 pounds and under one sixth gravity, that would only be 75 pounds, but the astronauts had great difficulty unloading it from the lunar module. Engineers on Earth had already determined that to operate under one sixth gravity, the rover would have to be 20' long and have a 20' tread. With a loaded earth weight of 1,600 pounds, it would need a turning radius of well over 80 feet to avoid tipping over at 10 mph or more than 20 feet at 5 mph and descending steep hills would not be possible without major problems. But, the astronauts did descend steep hills and they made very sharp turns at maximum speed.

One of the photographs brought back by the Apollo 12 trip, showed an astronaut carrying instruments hanging from a bar. The instruments had an Earth-weight of 190 pounds, supposedly 31 pounds on the Moon, but the pronounced bowing of the bar would not have been caused by just 30 pounds.

During the early Moon trips, the astronauts stated that when they left the atmosphere, the stars were not visible. This is understandable as the atmosphere scatters starlight, making stars appear larger and so become visible to the naked eye. Outside the atmosphere, there is no scattering and the stars are too small to be seen without a telescope. On the Apollo 11 trip, shortly before reaching the Moon, Collins stated "Now we're able to see stars again and recognise constellations for the first time on the trip. The sky's full of stars ... it looks like it's night side on Earth". This demonstrates that the Moon has a significant atmosphere caused by much higher gravity than one sixth that of Earth, although the refraction of light through that atmosphere is less than the refraction caused by Earth's atmosphere.

Mr Cater points out that NASA is well aware of the real nature of gravity and had electrogravitic drives long before the 1969 Moon shot. Not only that, but due to the fact that the Moon is bigger than currently believed, further away and possessing a higher surface gravity, that rocket power used during the flight was supplemented by an electrogravitic drive. Any honest person who has studied the evidence is well aware that there are many craft with electrogravitic drives and most of these seen in the last sixty years, are man-made. (All governments are very keen to suppress this information as national boundaries could not be maintained if electrogravitic drive vehicles were available to the public).

2. Relativity, proposed by Albert Einstein, is not correct and Mr Cater spends quite some time demonstrating that relativity is wrong. Prior to Einstein, the Transverse Wave Theory of light was universally accepted. Waves cannot exist without a medium which vibrates in some manner to transmit them. Therefore, the "ether" which permeates all of the universe was accepted. The Michelson-Morley experiment was set up to

test this. A ray of light was split into two parts which were made to traverse different paths of equal length. The motion of the Earth through the ether should then cause the recombined rays to show diffraction patterns. They didn't. It did not occur to anyone that if light were retarded by passing through the ether, then bodies such as planets would be seriously retarded by their passage through it and would slow down and stop. This experiment also gave rise to the ridiculous idea that the speed of light is a constant, in spite of the well-known fact that the speed of light through water is only 75% the speed of light through space. It was also proposed that the speed and direction of movement of an observer didn't matter, That time slows down on a moving system, that a body will shorten in the direction of motion and that the mass of a body will increase the faster that body moves. These are ridiculous suggestions. The famous $E = mc^2$ equation was actually derived from the Lorentz equations in 1903, two years before Einstein got into the act.

Physicists argue that particle accelerators demonstrate the increase of mass with speed. This is not the case and the experiments actually demonstrate a very important principle which provides a better understanding of many physical phenomena. It is an established fact that a magnetic field develops around a charged body when it is given a velocity. Where did the magnetic field come from? In the particle accelerator, as the particles accelerated, magnetic fields developed around them. As the total energy of the system remains constant, the magnetic field must have developed at the expense of the electrostatic field - the transformation of one kind of energy into another kind. This conversion from repelling electrostatic charges to magnetic fields causes the particles to clump together, giving the false impression of an increase in mass. Further, as the electrostatic component drops to almost zero, the accelerating force diminishes to near zero also, giving the false impression that a material body can't travel faster than the speed of light. The reality is that bodies can travel many times the speed of light.

According to General Relativity, a gravitational field will tend to slow the passage of time and the stronger the gravitational field, the more marked the effect. It was found that Caesium clocks run faster at high elevations than they do at ground level. This has been taken as a proof of the validity of Einstein's ideas. The concentration of soft particles is higher near the ground than at high elevations and that makes clocks run faster at high elevations. As to the speed of light not depending on the velocity of it's source, the Sagnac experiment of 1913 provides direct proof that the observed velocity of light **is** dependent on the velocity of it's source, disproving Relativity. Mr Cater provides extensive demonstrations (as do other people) that Einstein's deductions are not correct.

3. It is clear that gravity is responsible for the tides, but the standard explanation is wholly inadequate, being based on the assumption that gravitational effects have unlimited penetration. In other words, the only attenuation when passing through matter is due to the inverse square law, which actually would be a violation of the law of conservation of energy.

It is well known that a body cannot be given an acceleration relative to another body if both bodies experience the same acceleration. It follows then that since large bodies of water are accelerated relative to the Earth to cause tides, the water is being experiencing a different acceleration than the Earth as a whole, otherwise, there would be no tidal movement of water across the surface of the Earth. Assuming that gravity has unlimited penetration causes problems when accounting for tidal movements. Since the distances between the Sun and the Earth and the Moon and the Earth are large in comparison to the diameter of the Earth, all parts of the Earth will experience nearly the same gravitational attraction from these external bodies if gravity has unlimited penetration. High tides tend to occur when the Moon is at it's zenith, both directly underneath the Moon **and** simultaneously, on the opposite side of the Earth.

The Earth's orbit is inclined to the Equator by 28 degrees and so the Moon is never further North or South than 28 degrees. According to Newton's theory, the highest tides should occur near the Equator but the reality is that the highest tides are experienced much further away from the Equator, both North and South of it. Mr Cater provides an in-depth discussion of these effects, demonstrating that Newton's concept of gravity is wrong.

4. It is generally accepted that energy, in any form, flows from a higher potential to a lower one. The law of redistribution of energy states that when radiant electromagnetic energy interacts with matter, the resulting radiation as a whole, is of a lower frequency than the original light. This is why temperatures at lower elevations are generally higher than those at higher elevations, as sunlight passing through air converts to lower frequencies including infrared which activates the thermal motion of atoms and molecules, thus producing heat. Any dynamic unit is less active as a whole, than the individual parts comprising it. The higher ethers consist of the smaller, more active particles while the lower ethers are composed of the large, more complex and consequently less active particles. Both ethers occupy the same 3-dimensional space (which is the only space that there is).

When light of a given frequency range is produced, only the ethers associated with this light are directly activated. Light photons are composed of combinations of ether particles. Photons combine to form the penetrating particles which accompany this light. Particles composed of light in the lower frequency ranges are referred to as "soft" particles while those associated with gamma rays and above are referred to as "hard" particles.

Soft particles are more penetrating than the photons from which they are made, because, unlike the larger soft particles, photons have a relatively great surface area in proportion to their mass. Soft particles, and particularly soft electrons, play a vital role in all life processes and in other chemical reactions. The energy or field intensity of and around the higher ether particles is greater than that of the lower ethers. The diameter of a particle is inversely proportional to the average frequency of its constituent light.

5. The energies radiated from the Sun are continuously transformed into ever lower frequencies as they penetrate into the Earth. In this manner, nearly all of the original ultraviolet is transformed into lower frequency radiation by the time it penetrates the shell of the Earth. It is the transformation of some of the radiation from the Sun into gravity-inducing radiation which holds the Earth and the other planets in orbit around the Sun and give the illusion that the Sun has about thirty times Earth gravity. It should be mentioned that soft particles penetrate solid matter more readily than hard particles which are, of course, an integral part of matter.

All matter continuously radiates soft particles of many different kinds due to the interactions of the fundamental particles. These radiated particles undergo a transformation effect, according to the transformation law, when passing through large concentrations of matter. When this occurs, some of the radiation is transformed into gravity-inducing radiation. This is the source of some of the surface gravity of both the Earth and the Moon. The greatest contributing factor to Earth and Moon gravity is the transformation of radiation resulting from the thermal agitation of atoms and molecules. The particles resulting from this activity are comprised of lower-frequency photons. Such radiation is more readily transformed into gravity-inducing radiation because it is closer to this frequency band to begin with. A significant portion of this radiation, originating miles below the surface, is converted into gravity-producing energies by the time it reaches the surface. Most of the gravity radiation of the Earth and the Moon is created in the topmost fifty miles of their crusts. Below that level, much of the energy from the Sun has been transformed into softer particles, and that material of the Earth and Moon is permeated with them.

These soft particles screen out gravity radiation more effectively than solid matter does. This is because the ethers with which they are associated, are closer in frequency to the gravity radiation band. This explains why Moon gravity is nearly equal to Earth gravity. At the same time, it is clear why the Cavendish Experiment for determining the so-called "gravitational constant" was misleading – there wasn't enough material in the bodies used in the experiment to produce any radiation transformation. The gravitational effects produced by the bodies were due entirely to the thermal agitation of the molecules, without any transformation of radiation. The thermal agitation of molecules produces infrared and only an infinitesimal portion of this radiation is in the gravity-producing frequency range. This "gravity constant" plus the idea of unlimited gravity penetration, requires scientists to assume that the Earth has a tremendous mass and an iron core four thousand miles in diameter.

It is significant that some of the Cavendish Experiments indicated that gravity effects varied with the temperature. When the large sphere used in the experiments was heated, the smaller sphere had a greater tendency to move towards the larger sphere. When the larger sphere was cooled, the smaller sphere receded. This was explained away as being caused by convection currents although they failed to explain how convection currents could produce such an effect. A detailed account of this can be found in the 11th edition of the *Encyclopaedia Britannica* in the section entitled "Gravity". (If they felt that air currents were skewing the results, then the experiment should have been repeated inside a box which had the air removed).

As mentioned before, matter produces infrared radiations which are partially transformed into gravity radiations. In the case of mountain ranges, there is not enough matter to transform significant portions of such radiations into gravity radiations. Much of the radiation will escape from the tops and slopes of the mountains before they can be transformed, since their average heights are generally small compared to their horizontal dimensions. The gravity radiations produced deep in the interior of the mountains are partially dispersed by the overlying mass. This is the cause of the plum bob enigma which is a source of annoyance to conventional physicists because the plumb bob is not pulled towards the mountains to the extent demanded by Newtonian laws.

Another problem is that, in comparison to the Sun, the Earth radiates only an infinitesimal amount of

radiation per unit of surface area but it is able to keep the Moon in it's orbit around the Earth. Even allowing for infrared radiation passing from the Earth to the Moon and converting to additional gravitational radiation there, it still wouldn't be enough to keep the Moon in orbit unless the Moon were hollow and had a shell not more than a hundred miles thick.

In 1978, scientists were shocked to discover that some of the asteroids have moons which orbit around them at respectable velocities. According to Newton, this is impossible as the gravity of an asteroid would be far too feeble to allow this. When a body is a few miles across, it is large enough for gravitational radiation to be produced. This effect increases rapidly as the size of the body increases as far more infrared is transformed than is screened out by the outer layers of the mass. The effect continues until the body is about 150 miles in diameter and beyond that point, the screening effect of the outer layers keeps pace with the rate of increase of the transformation of infrared into gravity radiation. This means that all planets have practically the same surface gravity.

6. Mr Cater explains how soft and hard particles and the limited penetration of gravity account for Earth upheavals, continental drift, earthquakes and volcanoes. He also remarks that if the Earth were a completely solid ball and the Newtonian version of gravity were correct, then the Earth would be completely rigid and no Earth changes would occur other than some minor erosion, and there would certainly be no mountains left by now.

7. One of the most fundamental physical laws involves the relationship between the electrostatic and magnetic fields. One transforms into the other and vice versa. Inertia is a third factor involved in the relationship between the electrostatic and magnetic fields. The kinetic energy of a moving charge is manifested in it's magnetic field. The magnetic field increases at the expense of it's electrostatic field (as dictated by the law of conservation of energy). The role of inertia and the conditions governing it's magnitude are now apparent. The inertia of a body is dependent on it's ability to generate a magnetic field when it is given a velocity. The greater the inertia, the greater this ability.

The magnitude of the inertia of a body is directly proportional to the energy of the magnetic field which the body develops for a given increase in velocity. It follows then that inertia is dependent on the total electrostatic charge of a body. This is also true for so-called "uncharged" matter. In the supposedly uncharged state, all atoms and molecules have a net positive charge. Therefore, even atoms and molecules develop a magnetic field when they are given a velocity.

In 1901, Max Planck found that he could only derive the correct distribution in frequency of the radiant energy in the cavity of a black body as a function of the temperature of that body, if he assumed that energy exists in discrete units. He came up with $Nh\nu$ where N is an integer, ν is the frequency of the light involved and h is a universal constant (expressed in terms of energy multiplied by time, that is, erg-seconds). This is now known as Planck's Constant and is 6.6×10^{-27} erg-seconds.

The kinetic energy of a light photon is inversely proportional to the frequency. The lower frequency light, consists of larger and more massive photons travelling at the same velocity as the higher frequency photons. On average, the number of photons in any given ray, and the number of accompanying soft electrons will be a constant, regardless of the frequency. This is in accordance with the conclusion that the average distance, or mean free path between ether particles of the same kind, is a constant, regardless of the ethers involved. The average number of photons comprising a soft electron will also be independent of the frequency. This means that the diameter of the surface area of a soft electron, will also be inversely proportional to the frequency. Soft electrons accompanying light, travel at a velocity which is less than that of light. The soft electrons pick up speed, by bombardments of faster moving photons.

From a superficial glance, it seems that the average velocity of soft electrons should be independent of the frequency of the light associated with them. This is not so. The soft electrons associated with the higher frequency, travel at a higher velocity, and herein lies the key to the photo-electric effect. Although the lower mass of the higher frequency soft electrons is offset by the lower kinetic energy of the bombarding higher frequency photons, the surface area is greater in proportion to mass. This means that in proportion to mass, the electrons associated with the higher frequency light will receive a greater bombardment of photons and so, a greater accelerating force. The ratio between surface area and volume, or mass, is inversely proportional to the ratio between the diameter of two given spheres. Since the other factors balance out, it follows that the resultant average kinetic energy of soft electrons in proportion to mass, is directly proportional to the frequency of the light with which they are associated. As soft electrons collide with a surface, the hard electrons which they contain, are released and they bombard the surface, producing the photo-electric effect. They will be travelling at the same velocity as the soft electrons which housed them, so their average kinetic energy will be proportional the frequency of light.

Quantum mechanics is considered the most monumental achievement of twentieth century physics. In view of the principles presented above, it is not surprising that mathematical juggling with Planck's constant would account for many experimental results (in a quantitative sense). Quantum mechanics experts have enjoyed considerable success in this respect, especially in the realm of atomic spectra, without knowing why. In reality, quantum mechanics does not even qualify as a theory or a concept. It is merely an attempt to give mathematical descriptions of certain phenomena with Planck's constant and his valid assumption as a starting point. Modern "theoretical" physicists have absolutely no conception of why their mathematics agrees with certain experimental results. Yet, they have led themselves to believe that by giving mathematical descriptions of such phenomena, they have actually explained them.

It now becomes evident, why a mass can travel through space at a constant velocity, and encounter no decelerating force. The ether particles are so active that the closing forces at the back of the moving body, tend to equal the resistive forces encountered at the front. The rear portion creates a temporary void which is rapidly filled in by the surrounding ether particles, producing an effect very much like the Coander Effect. During the filling in process, the fundamental particles comprising the rear of the body are bombarded with ether particles travelling at a higher velocity than is normal. Also, the ether particles of which the mass is comprised are so relatively sparsely distributed throughout space, the situation is equivalent to a great mass travelling through a highly rarefied atmosphere.

8. During the creation of a photon, the ethers in the vicinity are suddenly compressed. Some of the ether particles are forced close enough together to adhere to each other. This aggregate is then propelled outwards with great force in a manner similar to a compressed spring being released. The photon reaches the speed of light after this accelerating force has been expended, which happens in a distance equal to the so-called wavelength. This process is repeated in the same region and another photon is produced which follows the first one, just one wavelength behind. A wide range of ethers are periodically affected during the production of ordinary light. This results in a countless variety of such particles being propagated in all directions with many different wavelengths. Since many photons are projected in all directions, many collisions will result, causing a significant portion to adhere to each other in aggregates.

The great majority of soft electrons are created during fluctuations in light velocity when passing through media of varying density, and even in its passage through outer space. Any slowing down, produces a backing up of photons and a consequent combining into relatively huge aggregates. In the beginning, these aggregates move much more slowly than the free photons. Consequently, some of the photons which were created at a later time, catch up and adhere to the aggregate. Their collisions with the aggregate particles causes the particles to speed up. This is the origin of the particles which always accompany light. Particles formed in this manner will vary greatly in size, stability and penetrating ability. It has been shown that soft particles will penetrate ordinary matter more readily than the hard particles. So, ether particles combine to form photons which in turn, combine to form light particles. This, light particles will disintegrate into photons.

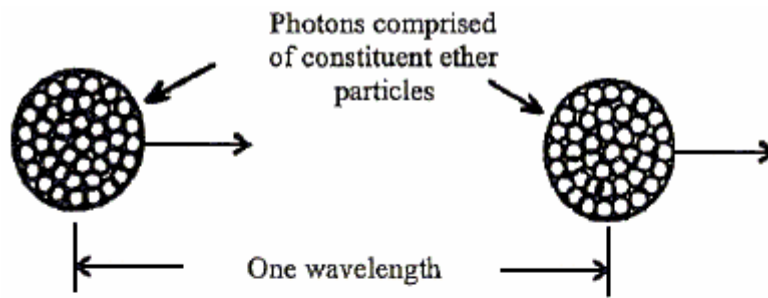

A typical beam of light made up of photons and soft particles

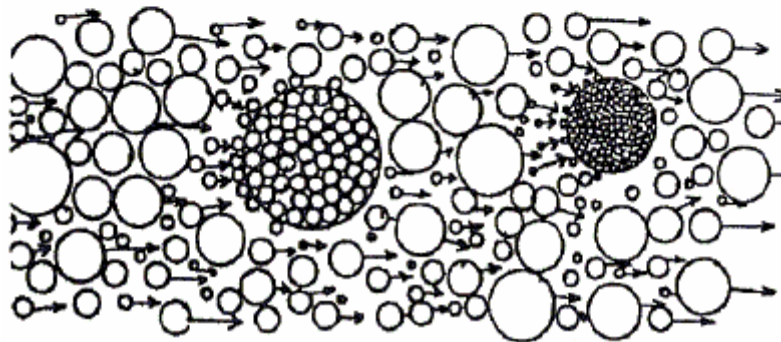

Atoms are comprised of hard particles which are uniform in size and structure and it follows that they were produced by an entirely different process. When light enters a medium, it encounters a conglomerate of soft particles created by the activities of the fundamental particles of the atoms which comprise the medium. This causes the light to slow down and the particles of light to crowd together inside the medium. If a beam of light enters a medium at an angle, the portion entering first will travel a shorter distance than the rest of the beam during the same interval of time. The portion of the beam entering the medium later is pulled by magnetic attraction of the particles, towards the side which reached the surface first. This causes the beam of light to be bent or change direction, accounting for the refraction of light which has never before been adequately explained.

Mr Cater then goes on to resolve the famous wave-particle paradox, and he also points out that the famous Michelson-Morley Experiments actually disprove the Transverse Wave Theory of light.

9. It must be realised that nature's laws are basically simple. To gain a deeper understanding of the nature of electrons, protons and electrostatic forces, it is necessary to look for an uncomplicated picture of the fundamental particles and the cause of their behaviour patterns. The collision laws involving the molecules of a gas can be applied to the ethers. Also, it can be deduced that electrostatic forces are the result of an imbalance of ether particles bombarding fundamental particles of matter.

It seems logical to assume that electrons and protons have a spherical shape as a sphere is the most stable and efficient geometrical form. It also has the smallest surface area for any given volume. However, such an assumption leads to insurmountable difficulties. Electrons and protons have a preferred direction of spin in relation to their direction of motion. The electron follows the left hand rule, while the proton spins according to the right hand rule. With a perfect spherical shape they could not have any preferred direction of spin. However, the preferred directions of spin can be readily accounted for if the particles are pear-shaped or egg-shaped and they are hollow.

When ether particles have a preferred direction of motion away from the electrons due to reflections, a pulsating electric field results. The excessive flow away from the electron tends to reduce the bombardment of incoming ether particles. A temporary low ether pressure around the particle is a result of this and in turn, this reduced pressure reduces the reflections and that causes the ethers to move in again and a sudden increase in ether bombardment results. This is something akin to the Coander Effect. The cycle is then repeated. It is to be expected that an electrostatic field is no exception and in this respect, "electrostatic" is a misnomer. The fluctuations are at such a high frequency that experimental results will see the (average) force as being a constant.

The behaviour of beams of electrons and protons in strong magnetic and electric fields indicates that protons have about 1836 times the inertial mass of electrons. Inertia is directly proportional to charge, indicating that the total charge of a proton is 1836 times as great as that of an electron. The idea that the hydrogen atom consists of one electron and one proton has never been questioned. To quote from a science magazine: "When protons crash into each other, they release showers of electrons, which suggests that protons are made up of particles more basic than themselves".

On the basis of relative charge effects alone, it follows that a hydrogen atom, instead of having only one electron orbiting a proton, that there are at least 1836 orbiting electrons. However, since the proton has relatively little movement in comparison to the electron, a far greater percentage of the electrostatic field of the electron has been transformed. This means that in order for the hydrogen atom to have close to a neutral charge, there must be thousands of electrons in one hydrogen atom. This seems to create a paradox as the amount of electricity required to liberate a given amount of hydrogen in electrolysis indicates that only one electron is necessary for every atom of hydrogen.

Scientists have never comprehended the source of the electricity that powers electrical equipment. There are unlimited quantities all around us, permeating all of known space. This hard electricity is camouflaged by softer particles which are also distributed throughout space. The flow of this limitless source of electrons can easily be set into motion. The electricity employed in electrolysis merely triggers the flow of far greater quantities. Also, when a hydrogen atom is ionised, it only needs to lose a very small percentage of its electrons instead of being reduced to only a proton.

Matter is rendered visible by the steady formation of soft particles generated by the activities of the fundamental particles. It is then apparent that frozen hydrogen would be completely invisible if electrostatic fields were not cyclic and the hydrogen atom had only one electron. Cyclic electrostatic fields are largely responsible for the complex spectral pattern of all of the elements. The cyclic pattern of hard-particle interactions is complex. This complexity increases rapidly as the number of fundamental particles in the atom increases.

Since electrons move at much higher velocities in the atom than protons do, they cover much more territory and so a higher percentage of their electrostatic charge is transformed into magnetic energy. This means that the positive charge in the atom will overbalance the negative charge and so, give the atom an overall positive charge. This explains why electricity tends to move towards ground and the Earth must possess a positive charge.

The electrostatic field effects near the atom in close proximity to the electrons, will be negative. Moving outwards, this negative effect diminishes quickly and a zone of positive field effect exists. The position and intensity of these zones, determines in part, the chemical and physical properties of the atom. There are regions where the atoms will attract each other and regions where they will repel each other. Ether particles have a similar structure and follow the same pattern.

The velocity of orbiting electrons in atoms is not uniform. There are periodic fluctuations resulting from mutual interferences within the atom itself and from adjacent atoms, in addition to the pulsating electrostatic fields. It must be noted that the properties of the atom are not observed individually, but as a collective group. The region of activity for the protons is relatively small and a significant number of electrons are trapped here. This region is the origin of neutrons, which are actually collapsed hydrogen atoms. It is interesting to note that when hydrogen is subjected to ultra high pressures, it behaves like a high concentration of neutrons and passes through the container which is being pressurised as though it didn't exist.

A more detailed discussion of the structure of the neutron is in order. The new concept of thousands of electrons comprising the hydrogen atom (to say nothing of the other atoms), provides, for the first time, a means of accounting for the properties of the neutron.

When a cloud of electrons orbiting the proton is forced into close proximity with the zone of repulsion, as described earlier, their motions become restricted. As a result, there is a lowering of the average velocity with a consequent increase in their negative electrostatic charge. This provides a stronger bond between the proton and the electrons. The orbital speed cannot be increased because of the zone of repulsion surrounding the proton, and the crowding of the electrons. The higher overall negative charge of the electrons almost completely cancels out the positive charge of the proton. The result is a particle which is electrically neutral, as far as most experiments can determine.

The electron cloud comprising the hydrogen atom is further removed from the proton and the individual electrons are not restricted in their orbital motions. The average velocity is much higher and consequently, the hydrogen atom has a high positive charge. The atoms of the gaseous elements, such as hydrogen and oxygen, are highly magnetic. Therefore, two atoms combine in much the same way as two bar magnets, to form a molecule consisting of two atoms. This is the reason why the molecules of nearly all the gaseous elements consist of two atoms. The combination has a still higher overall positive charge than a single atom has. As a result of this, the molecules have a strong mutual repulsion which keeps them widely separated at normal temperatures and pressures. Thus, they remain a gas even at extremely low temperatures.

The presence of electrons in the “nucleus”, nullifying repulsive forces, along with the magnetic fields resulting from the motions of neutrons, is the major source of the so-called “mysterious force holding the nucleus together”. In reality, the pinch effect of magnetic fields is the prime force which holds the atom together. Orthodox physicists have complicated the picture by claiming that many different forces exist: magnetic, electrostatic, gravitational, nuclear, and others to which they have ascribed odd names. In reality, only electrostatic and magnetic forces exist and there are two, and only two, basic particles – electrons and protons. Since the electrostatic field effects around the electron and proton are cyclic, the magnetic fields which they generate will also have a cyclic intensity.

10. Although neither spin when at rest, both the electron and the proton start to spin in a definite direction when they are given a velocity. This is contrary to the assertions of modern theorists who talk about particle spin with reckless abandon. The electron always follows the left-hand rule, while the proton follows the right-hand rule.

When placed in an electrostatic field, they move in such a manner that the large end is facing in the direction of their motion, regardless of their original orientation. The reason for this is not difficult to discern. If they are hollow and the shell is of a certain thickness in proportion to its diameter, then the larger end will have more surface area in proportion to its mass than the smaller end will have. The thickness of the shell at the smaller end will be much greater in proportion to its diameter. This means that ether bombardment at the larger end will tend to give it a greater acceleration than that imparted to the smaller end and as a result, the larger end will be forced ahead in the direction of motion.

The picture is still incomplete. In order for the particle to have a preferred direction of spin, the frontal surface must be grooved in the manner of a right-hand or left-hand screw. Such a shape is consistent with recent experiments at the *Argonne National Laboratory*, which studied the shattering of proton beams aimed at target protons. The results indicated that protons are not spherical. A detailed account of such experiments can be found in the article “The Argonne Experiments and The End of Quarkery” by Eric Lerner which appeared in the Oct-Nov 1997 issue of *Fusion Magazine*. In the article he showed that some of the basic assumptions of quantum mechanics are contradictory, and he dispensed with the popular theory in particle physics which assumed an ever-growing family of hypothetical particles called “quarks”.

It has been noted that a magnetic field surrounds a moving charge. The magnetic lines are in the form of circles. An electron or proton tends to carry ether particles around with it in a circular motion as it moves through the ethers. This is due to the mutual repulsion between the ether particles and the ether particles comprising the particle. The reactive forces cause the particle to spin and they produce a vortex motion in the ether itself. The greater the velocity of the particle, the faster it spins and the more ether particles are caused to flow around it in the direction of the spin. It is this flow of ether particles around a moving charge which produces the magnetic field effects observed. A three-dimensional view of this magnetic field shows that it resembles a corkscrew spiral or vortex.

The ether particles which would normally cause repulsion between two adjacent particles at rest, spin when they both move and the electrostatic repulsion drops off and is replaced by a magnetic field which draws the two particles together. This effect is also seen in two adjacent wires carrying a heavy current flowing in the same direction. The wires are drawn towards each other.

If two unlike charges move along together, they spin in opposite directions, generating magnetic fields of opposing polarity which tends to push the particles apart.

An electron or proton moving in a magnetic field has two forces acting on it. One force tends to push it down the magnetic lines of force because of excessive ether particle bombardments in one direction of flow. The other force is perpendicular to the lines of force. If the velocity of the particle is high, then the latter force is by far the more significant. This force is a result of Bernoulli’s principle. Magnetic fields tend to capture large quantities of soft electrons.

11. The conventional theory of geomagnetism lacks merit. According to it, the major portion of geomagnetism is the result of electric currents flowing in a molten iron core 2,000 miles beneath the surface of the Earth. Even if such a core did exist, the conclusion would still be false. Scientists are somewhat vague as to how a magnetic field could extend 2,000 miles beyond an electric current considering that it takes a very powerful current to produce even weak magnetic effects a short distance from the current flow. The electrical resistance of iron at the alleged temperatures of the core would be staggering, which raises the question of how the necessary massive potential difference is produced to drive a large current in the core in the first place.

A great wealth of evidence supports the conclusion that geomagnetism is produced by the Earth's rotation. The intensity of the field is dependent on the concentration of negative charges in the atmosphere and the crust and on the rotational velocity. Since the concentration of charges in the atmosphere fluctuates in a 24-hour cycle, the magnetic field can be expected to fluctuate accordingly. This is an established fact.

Supposedly uncharged atoms and molecules are not electrically neutral, but possess a positive charge. It has always been assumed since the days of Newton, that inertia is directly proportional to mass. This has been shown to be incorrect as inertia is dependent on total charge and is therefore independent of mass. It follows that an atom has less inertia than any of the fundamental particles of which it is composed. The small overall charge of an atom is the result of the equalising of positive and negative charges. It's slight ability to generate a magnetic field for a unit increase of velocity is due to electrons following the left-hand rule while protons follow the right-hand rule. The inertia of an atom is limited because the magnetic fields of the electrons and protons from which it is constructed, cancel each other out to a major degree. Stripping electrons from an atom will give it a strong positive charge and much greater inertia even though it now has less mass. Adding electrons to it can also raise it's inertia if the extra electrons cause it to end up with a greater overall charge than it had before. The Nobel Prize winner Gabriel Lippman confirmed this when he found that bodies in a charged state have greater resistance to acceleration than they have in their uncharged state.

Since matter behaves like a positive charge, it follows that gravity radiation will accelerate positive charges in a direction opposite to that of the direction of its propagation. A gravitational field repels negative charges. When the hair on a person's head is given a strong negative charge, it stands straight up due to the negative charges on the hairs carrying the hairs with them as the charges are pushed upwards by gravity.

The bulk of the radiations and soft particles of matter cover only a relatively narrow part of the electromagnetic spectrum. They are produced by the interactions of the fundamental particles of the atom in addition to the interactions of the atoms themselves. Incidentally, it is the soft particles comprised of photons close to, and in, the visible range which permeate matter that make matter visible. If only the hard particles were present, solid matter would be invisible, although completely tangible.

The leading part of the gravity radiation front produces negative charge effects, while the trailing portion which has passed a given body must have substantially reduced negative charge effects. The spin of the particles in gravitational radiation have a gyroscopic effect which keeps the particles orientated in the same position and the particles have little tendency to scatter.

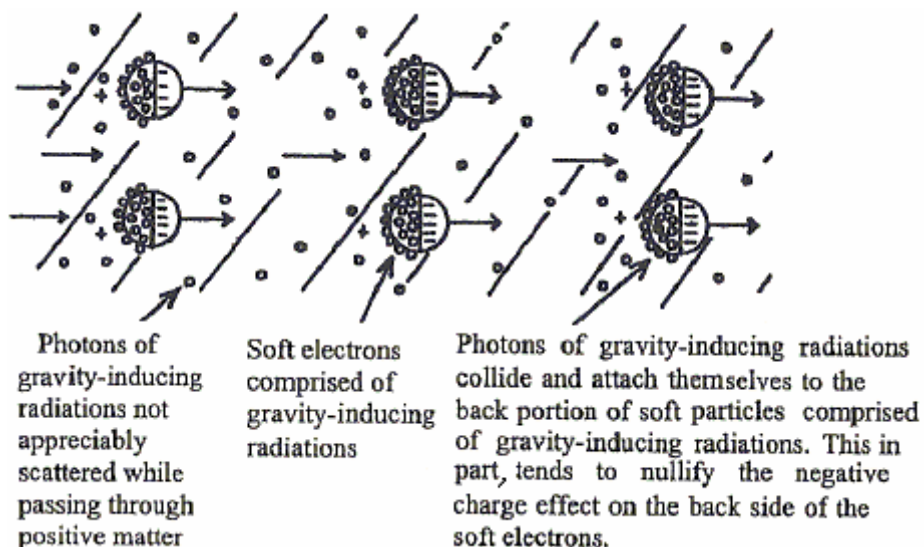

The faster moving photons overtake the soft particles and tend to adhere to them in irregular patterns, creating a perforated and extremely rough surface on this part of the particle, not unlike that of a positive charge. This has a tendency to cancel out much of the negative field effects on this part of the particle. The bombardments accelerate the particles to such an extent that no more photons can adhere to them. Therefore, the rear part maintains a positive charge, or at least, a much reduced negative charge.

Another important factor which contributes to a reduced negative charge at the rear is that there is a far greater photon concentration in this region than exists at the frontal portion. This is a result of a backup of photons caused by the lower velocity of the soft particles accompanying the radiation. This photon concentration tends to divert the normal ether bombardments (which produce the electrostatic effects) from their usual paths. Since gravity radiations produce forces, it follows that there are interactions which eventually disperse the radiation, accounting for the limited penetration of gravity radiation. Gravity is an electrostatic effect, not some space warp or mysterious force with imponderable properties. If matter is impregnated with sufficient quantities of negative charges, especially soft electrons, it will become weightless and even levitate.

Some individuals have the ability to do the reverse of levitation, possibly by expelling large quantities of negative charge from their bodies. A dwarf who had a normal body weight of 123 pounds demonstrated under strict anti-fraud conditions that he could increase his weight to 900 pounds.

The physics of levitation was demonstrated in part when missiles were found to have lost most of their original weight after travelling through the Van Allen Radiation Belt and returning to Earth. The weight loss continued for some time and containers in which pieces of the missile were placed, also lost weight. The radiation belt contains high concentrations of negative charges of all kinds, from hard electrons to the very soft ones. The missile became impregnated with negative charges as it passed through this region, absorbing an abnormal quantity. The more penetrating softer particles opened the door for the harder particles to enter. The loss of weight of the container would have been caused by the missile gradually losing some of its excess negative charges and those charges being absorbed into the container.

12. Faster than light travel is possible because the accelerating gravity beam travels with the mass being accelerated. At ultra-high velocities, or where most of the electrostatic potential of matter has been transformed, cohesive forces will tend to break down and the material will cease to be a cohesive solid. However, spaceships can travel many times the speed of light provided that the ship and the occupants are impregnated with the right combination of negative charges which would prevent any extensive transformation of the electrostatic mass into magnetic energy. At ultra-high velocities, the closing forces on the rear of the craft no longer compensate for the forward resistance, so it requires a steady application of accelerating forces to maintain velocities many times that of light.

The evidence concerning spaceship propulsion demonstrates that the famous Einsteinian equation $E = mc^2$ falls far short of representing the energy potential of matter. From the kinetic energy equation $E = 0.5mV^2$ it follows that a body travelling at only 1.5 times the speed of light (which isn't even a cruising speed for most spaceships) has a kinetic energy which exceeds the value of Einstein's celebrated equation. At this velocity, only a miniscule part of the energy potential of the mass has been released. The meaninglessness of the famous equation is also evident, because inertia is dependent only on net charge and not necessarily on mass or quantity of material.

13. Another item which demonstrates the validity of the information presented here is the fact that determinations of the gravity "constant" "g" is always significantly higher when measured in mines. This is to be expected as the soft electron concentration is much higher below the surface than it is above the surface. Another fact which disturbs physicists (and consequently given little publicity) is that objects at the bottom of mine shafts weight significantly less than they should according to Newton's concept of gravity.

Another enigma which is damaging to the academic viewpoint is that experiments indicate that gravity doesn't impart the same acceleration to all substances. To try to deal with this fact, they have to introduce a mysterious fifth force which is supposed to be an extremely feeble repulsive force with a limited range. It is supposed to be more prevalent in some substances than in others. The concepts already explained here show that this is to be expected. Different atoms and molecules have different total positive charge effects in proportion to the number of fundamental particles from which they are made. Consequently, they will not be given the same gravitational acceleration even if the mass is identical.

14. We now come to questions such as; How does the law of redistribution of energy work? What are the real principles behind colour perception? Why is the velocity of light independent of its frequency? Why is this velocity equal to the ratio between an electromagnetic and electrostatic unit of charge? The answers to

these questions have never been given before.

When materials are subjected to high temperatures, great fluctuations occur in the velocity of electrons in their orbits. This in turn, creates interactions and interference effects between electrons moving in opposite directions inside atoms and between electrons in adjacent atoms. These interactions generate changes in the electrostatic field effects of the electrons, which will cause regular and distinct changes in their so-called orbits. This is because the charge on the electron varies with its velocity. Abrupt changes in the velocity of a particle disrupt the ethers which results in the formation of photons.

The larger the atoms, the more complex the interactions, and consequently, the more intricate the spectral pattern. The photons comprising the electrons, determine the range of the ethers which will be disrupted. These ethers are intimately connected with the electrostatic field intensity of the electrons. Thus it follows from this new definition of Planck's constant, just why this definition must be taken into consideration in all of the calculations concerning the frequency of light produced in interactions.

The electrostatic field effects around an electron depend on the range and level of the ethers deflecting off the sides of the particles. This range is not necessarily the same as the range of ethers affected by sudden changes in the velocity of the electrons, but there is a direct correlation between the two. Planck's constant has a role throughout the procedure as all ether particles have the same kinetic energy.

The law of redistribution of energy states that when light interacts with matter, new light with a lower average frequency than the original is produced. One of the most simple demonstrations of this is shining a blue or violet light through a large number of filters of any type. The emerging light is always red. All of the colours which we normally see are combinations of different frequencies of photons. A wide frequency range of soft particles and photons will tend to be grouped together. This means that bands of light in the blue, indigo and violet ranges will contain other colours down to the reds, although the reds will make up only a very small percentage. The human eye sees only the dominant colour, and prisms cannot separate them. The colour experiments of Edwin Land proved this to be the case.

In the May 1959 issue of *Scientific American*, Land showed that two black and white transparencies produced from black and white film, were exposed to filtered light from two different (reasonably spaced apart) parts of the spectrum, the resulting superimposed images were in full colour. This shows that it requires subtle combinations of frequencies for the eye to perceive colour if the light isn't in a narrow frequency band. Otherwise, the eye will see things in various shades of black and white, which contain all the colours but in the wrong combinations to be seen as colours. This is what occurs for people who are subject to 'colour blindness'.

Under certain conditions, light reflected from a mirror can have greater intensity than the incoming light. The light has to be of high intensity. When the particles of the incoming light collide with the mirror, those that are reflected are instantly brought to a halt. This produces a tremendous disturbance of the ethers which results in the creation of new photons which are added to the photons which are reflected. In addition, many of the photons reflected and created, combine to form soft electrons, and so the reflected light has a higher percentage of soft electrons than the incoming light beam.

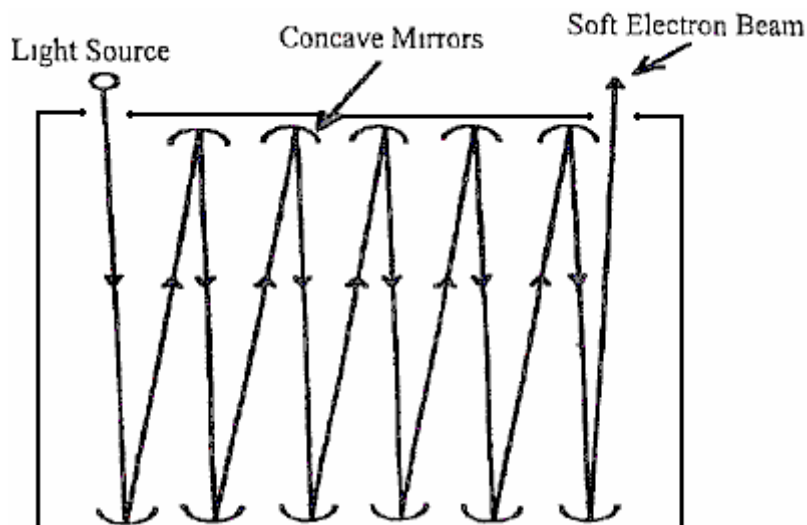

It follows that repeated reflections of a light source such as the Sun, would result in a highly lethal laser-like

beam. This has been demonstrated on numerous occasions. Perhaps the most notable demonstration occurred near White Sands, New Mexico in the early 1950s. It was witnessed by an acquaintance of a personal friend of Mr Cater's, and it was something which he wasn't supposed to have seen. About thirty-five four foot diameter mirrors were arranged so that the resulting beam was directed at the rock wall of a mountain. It immediately created a neat hole through 200 feet of solid rock.

An associate of Mr Cater's found that by putting a strong negative charge on the mirrors that their reflective power is considerably increased. He charged a series of metallic mirrors to 20,000 volts and found that after 10 repeated reflections from the Sun, the resulting beam was very lethal. This shows that it is the negative charges deposited on a mirror surface which enables it to reflect most of the light that falls on it. Incoming light immediately deposits negative charges on the surface and those charges repel the rest of the light. The more intense the incoming light, the higher the concentration of negative charges placed on the surface. This accounts for the fact that highly lethal beams reflecting from the surface do not destroy the mirror. The mirrors must be metallic and preferably concave. Glass mirrors do not work as much of the incoming light is lost before it reaches the reflecting surface and much of the shock effect of the light reflection is lost due to the glass slowing down the incoming beam. The incoming light must strike the mirror in as nearly a perpendicular direction as is possible. If soft electrons associated with colours known to be highly beneficial could be concentrated using this method to produce rapid healing

15. The question arises: Why is the velocity of light independent of it's frequency? This is implicit in Maxwell's equations but it still isn't explained. When the ethers are disturbed to produce a photon, a fraction of them are compressed and a great number are forced close enough together to adhere to one another. The higher the ethers affected, the more rapidly and suddenly this displacement has to occur in order for a photon to be produced, otherwise, the ether particles will escape this compression since they are very active. This momentary compression quickly returns to normal, rather like a compressed spring being released. This rebound hurls the aggregate photon forward at the speed of light. The distance of this rebound is equal to the so-called wavelength, or distance over which the photon is accelerated to the speed of light.

This is exactly what happens when lower ethers are disturbed to form lower frequency photons, except that the rebound takes place over a greater distance with a lower average acceleration of the photon. Since the warped pattern is identical in both cases, both photons reach the same velocity, which is independent of the actual wavelength produced. As both photons receive the same thrust, it can be seen that lower frequency photons must have a greater mass, that is, the frequency of light is inversely proportional to the mass of the protons which form that light.

The behaviour of electrons and protons in a particle accelerator shows that at the speed of light, all of their electrostatic potential has been transformed into magnetic energy. This shows that the velocity of light relative to it's source is the ratio of it's Electromagnetic Unit of charge ("EMU") and it's Electrostatic Unit of charge ("ESU"). The ratio EMU / ESU is equal to the speed of light "C". Calculating from these details, shows that the total pressure exerted on a single electron by the surrounding ethers is 14.4 dynes which represents a pressure beyond normal comprehension when the minute size of an electron is considered.

16. We now need to consider the role of soft electrons in promoting chemical changes and maintaining life. It has been repeatedly confirmed that magnetic fields have considerable healing properties and will stimulate plant growth. What has not been realised is that it is not the magnetic fields themselves which are responsible for this effect, but it is the soft electrons which they capture and concentrate. One pole of a magnet has beneficial effects for certain ailments, while the opposite pole is not as effective.

One of the most significant properties of soft electrons is their ability to promote chemical changes. A change in a molecule is not likely to take place without lessening the chemical bond or attraction among it's constituent atoms. Soft particles interpenetrating the molecule will bring about this condition by carrying harder electrons in with them, which in turn weakens this bonding by offsetting the positive charge effects of the nucleus. Soft particles tend to camouflage a variety of harder particles. This is a vitally important property because in this manner, other atoms which are going to take part in the chemical change, also have their zonal effects temporarily altered so that they can come into more intimate contact during the reaction. The soft particles tend to act as catalysts for the reacting particles and the soft particles tend to get disintegrated in the process, releasing additional energy which expedites the reaction and allows the normally powerful electrostatic field effects within the atom to return to their original state. The release of the hard electrons contained within the soft particles which disintegrate is the source of much of the heat produced during chemical reactions.

17. The properties of water: water is a universal catalyst because of it's unique ability to collect and concentrate an enormous quantity of soft electrons of all kinds. This is the reason why water has the highest

specific heat of any known substance. The large amount of energy contained in water in the form of soft particles, has been demonstrated by experimenters on many occasions. For example, a number of reports show internal combustion engines running with water as the fuel. No reasonable explanation for this has been given as it appears to be contrary to all the rules of chemistry. However, the disintegration of the more unstable soft particles contained in the water when subjected to compression and ignition inside the engine, accounts for this seeming impossibility.

Water is a unique substance being comprised of two of the most chemically active elements, both of which are gaseous elements. The fact that three oxygen atoms can combine to form ozone, indicates that the oxygen atom is extremely magnetic, indicating that a higher percentage of its orbital electrons are moving in approximately the same plane. This leaves fewer orbital electrons tending to offset the positive charge of the nucleus and other portions of the atom. Consequently, two sides of the oxygen atom possess an inordinately strong overall positive charge. When hydrogen atoms combine with an oxygen atom, the electrons on the side of the hydrogen atoms adjacent to the oxygen atom are brushed aside. This is on the segment of the oxygen atom where most of the electrons of the oxygen atom are orbiting. The normal flow of electrons around the proton of the hydrogen atom is diverted to become a flow which encircles the oxygen atom and the outer periphery of the hydrogen atoms. This results in a powerful magnetic and electrostatic bond between the hydrogen atoms and the oxygen atom. The electron flow around the hydrogen atoms is extremely rapid, resulting in a very high overall positive charge on the hydrogen atoms. As there is a very strong mutual repulsion between the hydrogen atoms, they will line up on opposite sides of the oxygen atom, giving water the structure H-O-H. This molecule has strong and extensive positive zones, so the attraction zone is a considerable distance from the molecules. This is why the specific gravity of water is low, despite the strong positive charge of the molecules.

The great affinity of water for soft electrons is now apparent. The large positive zones between molecules are havens for soft electrons, drawn there by the attenuated, but significant, attraction of the hard electrons captured by the soft electrons. Although soft electrons are large compared to hard electrons, they are still very small compared to an atom. Therefore, the spaces between water molecules can harbour large quantities of soft electrons, without them being bound to the water molecules.

Perhaps the most baffling feature of water is that it expands when it freezes. The high concentration of soft electrons greatly weakens the forces of attraction and repulsion between the molecules. As a result, the average kinetic energy of the molecules at the freezing point are still sufficiently large to allow the molecules to move in and out of the zones of attraction and repulsion, without being confined in the attraction zone. The cooling must continue until the soft electron concentration reaches the stage where the attractive forces become strong enough to confine the molecules to the attractive zone. When this occurs, the water becomes a solid. Since the attractive zone is an inordinate distance from the molecules, the average distance between molecules becomes greater than it was when the water was in a liquid state. At the freezing point, the molecular activity is low enough to permit soft electrons to enter or leave the substance without disintegrating. In order for the water to be transformed from a solid back into a liquid, the same quantity of soft electrons must be injected into it as were removed when it changed from a liquid to a solid.

The melting and freezing temperatures of water vary considerably due to the differing amounts of soft electrons contained in it. Another unusual feature is that in cold weather, hot water pipes have a greater tendency to freeze than cold water pipes do. This is because the heating of the water drove off many of the soft electrons normally contained in the water and due to the low temperature of the surroundings, these soft electrons were not replaced, and as a consequence, freezing to become a solid happens more easily.

One tends to think of colloids as ultra-small particles of solid matter. However, molecules of water can adhere to each other to form aggregates of water molecules, which are effectively, colloids as well. Colloids have strong electrical properties as indicated by the fact that they are not affected by gravity. The field zones around any such colloidal group will be much stronger than that around a single water molecule. Water with a high percentage of such colloidal groups can capture a very large number of soft electrons which are beneficial to health. Abnormal conditions in certain places can favour the formation of water colloids and that can account for the healing properties of water found in some places, such as Lourdes in France.

18. Hard particles can be captured by softer particles and this is deeply involved in a wide range of phenomena, from the transmission of heat and electricity, to the formation of clouds.

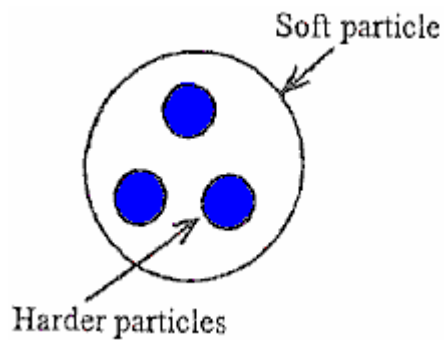

Two particles differing greatly in the frequency range of photons of which they are comprised, have little tendency to repel or attract each other. Therefore, they tend to interpenetrate.

Ether particles have zones of attraction and repulsion. Since photons are composed of ether particles, they will in turn, possess zones of attraction and repulsion. In the case of ether particles, these zones will be correspondingly smaller in proportion to the diameter of photons. When protons combine to form electrons or protons, the same zones are present between these particles. However, the zones of attraction are minute when compared to the diameter of the electron or proton, and like particles, seldom if ever get close enough together at sufficiently low velocities for the attractive forces to become effective.

The situation is entirely different when two similar particles composed of photons but with widely differing frequencies, approach each other. Electrostatic attraction or repulsion is considerably lessened because each is associated with ethers which differ considerably from each other. When they are in direct contact with each other, electrostatic repulsion tends to vanish, since there can be little or no bombardments on the sides facing each other. Since each particle associated with ethers is somewhat different, they will tend to interpenetrate. This means that they will be completely within the ether attraction zones of one another. As a result, the harder particle is captured by the softer one. In a similar manner, the captured harder particles will, in turn, capture still harder particles and this process continues until electrons normally associated with electricity are confined. This combination of particles tends to nullify the electrostatic forces which are normally produced by the confined particles, camouflaging the captured harder particles so that their presence is not readily apparent.

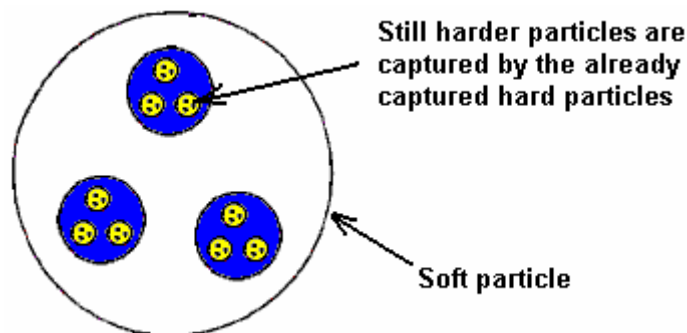

The ether particles normally bombarding the hard electrons and protons which produce electrostatic field effects, tend to be diverted from their normal paths by the presence of softer particles or media between the repelling like charges and/or the attracting unlike charges. These interpenetrating softer particles produce an ultra-high concentration of ether particles around the hard particles. The motion of these ether particles is greatly restricted. This offers a barrier to the higher ether particles which normally bombard the hard particles. This has a tendency to slow them down, and any which do collide with the hard particles, do so with considerably less impact than normal, therefore they tend to become electrically neutral and their motion slows to nearly a halt.

Soft particles permeate matter as well as the spaces between matter, yet they do not to any great extent, neutralise the electrostatic field effects of the fundamental particles, because they are more concentrated and their rapid motion tends to prevent capture. However, additional concentrations of soft particles of the right kind, injected into matter, can render the elementary particles within the atom, electrically neutral and the matter becomes what is known as "dematerialised". This conglomeration of soft and hard particles renders the soft particles electrically neutral.

It should be noted that only hard particles or the fundamental particles of the atom, are hollow. All other particles, including photons, do not have this tendency because of the nature of their formation. If the softer particles were hollow, they would be unable to capture harder particles. Hard particles entering a hollow, soft particle, would maintain their charges and force a mutual repulsion. Therefore, they would escape

immediately. Photons, if hollow, would tend to be less stable, and the probability of forming other particles would be lessened.

When a soft particle disintegrates, a chain reaction occurs. The disintegration releases the confined, harder particles. The energy released during the disintegration is generally sufficient to disintegrate the weaker hard particles which it originally captured. This, in turn, results in the disintegration of still harder particles, until the very hard and stable electrons of electricity are released. Highly interesting experiments performed in Poland by two scientists; Howsky and Groot, demonstrated the ability of soft electrons to house and camouflage harder electrons, and to release them under certain conditions. These experiments were also a great confirmation of other principles already mentioned here, especially those involved with levitation.

A small quartz crystal was attached to an oscillator which generated radio frequencies of several kilowatts. This caused the crystal to lose its transparency and increase its volume 800%. The crystal then levitated and carried the oscillator, as well as a 55 pound weight, to a height of two metres above the floor. An account of this was given in an issue of *Science and Invention* magazine and it included a photograph of the levitation.

19. The energies concentrated inside a pyramid have been shown to be extremely beneficial to humans. Soft particle bombardments from outer space and especially from the Sun, concentrate inside the pyramid. Some, passing through the surface of the pyramid are slowed down to such an extent that the Earth's gravitational field, repelling the negative charges, tends to keep them inside until collisions with other particles drives them out.

Most of the particles collected by the pyramid, concentrate along the edges as would be expected, since electricity on any charged body tends to do much the same thing, with concentrations at points and along edges. In fact, pyramid frames have been found to be nearly as effective as the closed pyramid, if, and only if, there is a continuity in the framework and no breaks in any of the joining parts.

The soft electrons collected on a pyramid frame or closed pyramid, soon reach saturation point and continued bombardment causes the excess to drop down inside the pyramid. This, coupled with the gravity-repelling forces, causes a high concentration inside the pyramid. The proportions of the pyramid are apparently a factor in its performance. If the sides are too steep, many of the soft electrons will move along the edges into the ground outside instead of being forced inside the pyramid. If the sides are not steep enough, not many particles will be collected as they strike the material at nearly a right angle which causes only a small reduction in velocity. If they strike at a sharper angle, there is a greater tendency for them to be retained by the material.

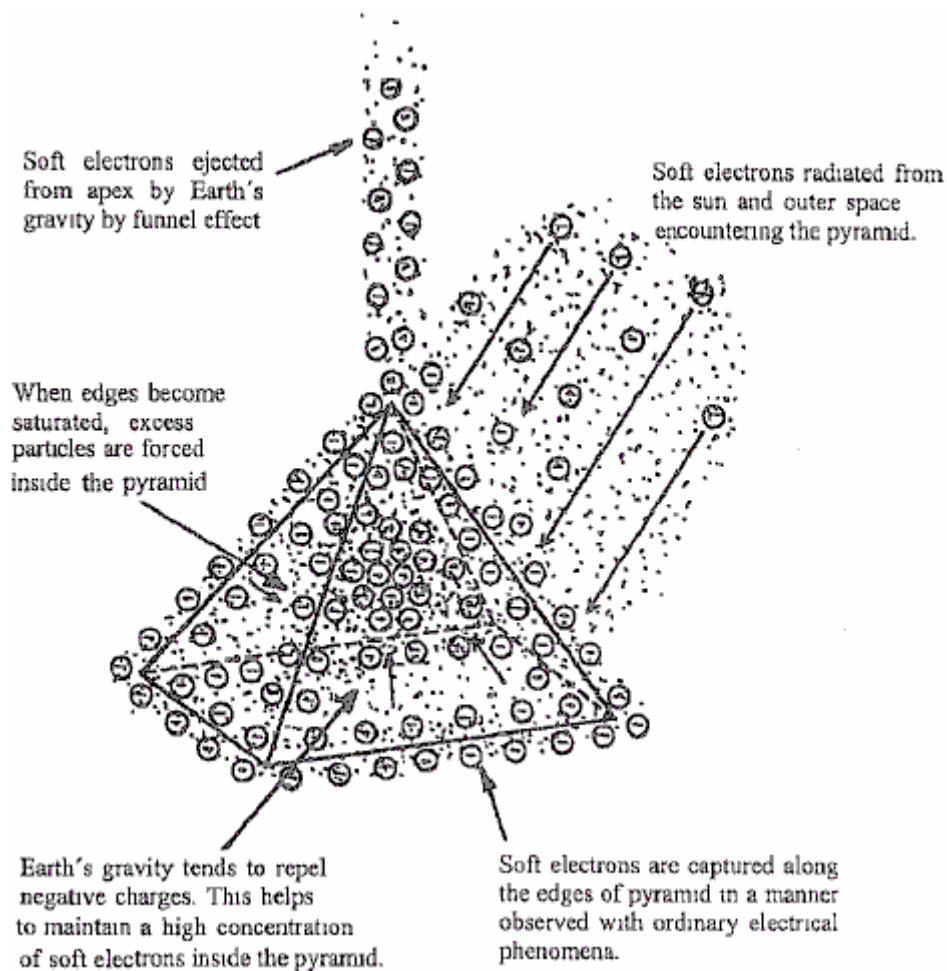

If two sides of the base are aligned with magnetic North, it is allegedly more effective. Pyramids can be rendered more potent by lining the interiors of a non-metallic enclosed pyramid, with metal foil such as aluminium or copper. The foil allows a greater quantity of soft electrons to accumulate around the non-metallic outer portion because the soft particles do not pass through the metallic substance as easily, causing a back-up of soft particles. During the process, the foil absorbs large quantities of soft particles before many of them can enter the pyramid. pyramids also radiate soft electrons upwards from the peak.

Many of the soft particles which are stopped briefly on the outside of the pyramid, are repelled upwards by the Earth's gravitational field, and as well, by soft electrons attached to the pyramid. This produces a funnelling effect which ejects soft electrons from the apex of the pyramid. The Earth's gravity accelerates soft particles at a far greater rate than it does ordinary matter as soft particles are associated with ethers which are much closer to those of the gravity-inducing particles than is the case for ordinary matter. After the pyramid becomes saturated, a greater quantity of soft particles than ever, will concentrate inside. The foil will continue to radiate a high concentration of soft particles during the night when the number of particles bombarding the pyramid is considerably reduced.

It is found that pyramids work better during the summer than at any other time of the year. They are also more effective in the lower latitudes because most of the energy concentrated by the pyramid comes from the Sun. There are conflicting opinions as to the effectiveness of pyramids because of this as there is little understanding of the principles involved. For example, those who experiment with pyramids in Canada may claim that they don't work while those in Southern California will contradict them. A pyramid does not increase the flow of soft particles through the area covered by the pyramid as the same concentration flows outside the area. What a pyramid does, is impede the general flow of soft particles and produce a back-up of particles inside and below the pyramid, and consequently, a higher concentration of soft electrons in these regions. The material used in a pyramid is of great importance. This was demonstrated when a wealthy man in the Midwest built a pyramid-shaped house five stories high, which was then covered with gold-plated iron. The phenomena produced were completely unprecedented. For example, ground water was forced to the surface and flooded the first floor. This was because the soft particle concentration inside and below the pyramid was so great that ground water was impregnated with such an abnormal concentration of negative

charges that it was repelled upwards by the Earth's gravity.

Gold atoms have extremely high positive electrostatic field effects, more so than any other atom. This is why gold is the most malleable of all substances. This means that soft electrons will have a greater affinity for gold than for any other metal. As a result, abnormally high concentrations of soft electrons will concentrate around gold. This effect is greatly enhanced when gold is in contact with iron. These dissimilar metals produce an EMF which in turn, causes a flow of electricity or eddy currents resulting in the iron being magnetised. The magnetic field produced, captures additional soft electrons. A higher concentration of soft electrons is created by this combination than could be produced by a similar thickness of gold foil alone. It follows that by far the most effective material that could be used for pyramids is gold-plated sheet iron (galvanised iron should not be used).

With everything else being the same, the greater the size of a pyramid, the better the performance. The reason for this is that the thicker the layer of concentrated soft electrons through which the incoming soft particles must pass, the more they are slowed down when passing. This results in a greater back-up of soft electrons and an increase in the concentration inside the pyramid. Another reason is that a large pyramid has a greater ratio of volume to surface area. Soft electrons are continuously leaking away from the surface of the pyramid, the larger the pyramid, the lower the percentage of soft electrons which is lost. Consequently, very small pyramids are ineffective.

20. Viktor Schauberger of Austria was puzzled by the fact that large mountain trout could remain motionless for as long as they liked in the fastest flowing water in streams. When disturbed, they escape upstream with fantastic speed. He also noticed that water gets charged up through swirling vortex action as it flows around obstructions. As the water is highly agitated, it gives up large quantities of hard and soft electrons to the fish, causing the entire outer surface of the fish to get a high negative charge. This charge repels the outer electrons of the water molecules, totally eliminating drag and as a result, the water exerts almost zero force on the fish. This effect is even more enhanced as the fish moves upstream, much more so than if the fish went downstream. The negative charge also helps the fish jump as the Earth's gravity boosts it upwards.

21. Brown's gas, produced by one form of the electrolysis of water has properties which seem bewildering to most scientists. Using it, allows steel to be welded to a clay brick and the flame is not harmful to human flesh. The flame temperature depends entirely on what it is applied to. It can also reduce nuclear radiation by 96%. The properties of Brown's gas confirm the information above. Water has a very large capacity to store soft electrons in addition to those already present in the structure of water. Brown did not separate water into hydrogen and oxygen. Instead, he added additional soft electrons to the water molecules. These additional charges greatly weakened the cohesive forces between the molecules, converting the water to an unstable gas. All of the properties of Brown's Gas follow naturally from this. Under welding conditions, the vast concentrations of soft electrons supply the release of sufficient quantities of hard electrons to produce the needed heat. In addition, the soft electron concentrations enable iron atoms to partially interpenetrate brick molecules to produce a bond between brick and iron. Also, with the ultra-high concentration of soft electrons, the gas can readily neutralise the positive charges of nuclear radiation.

22. We need to examine the source of the Sun's radiant energy. One thing that all suns seem to have in common is their great size. The astrophysicists speak of white dwarf suns of planetary size or less. It is clear that any claims made by astronomers or astrophysicists concerning celestial determinations, have about the same degree of merit as the other scientific claims which have already been mentioned. There is nothing to justify the existence of a white dwarf. For one thing, due to its allegedly small size and limited gravitational influence, it could only hold very small bodies of asteroid size in orbit around it and those would have to be only a short distance away from it. According to the fallacious theories of orthodox science, a white dwarf consists of atoms with practically all of their electrons stripped away, giving it enormous gravity. It will be shown that astrophysicists have no way of accurately determining the distance or the size of any celestial body.

The larger the body, the greater its mass or volume in proportion to its surface area. This means that as the size increases, it is less probable that the energies produced by the normal activity of the atoms in the body's interior will escape from the surface without a resulting increase of temperature at the surface. The energy radiated from the surface will be in the form of photons and other particles of all types. Below a critical size, the surface area is sufficient to allow all of the radiant energy created in its interior, to escape without an increase in temperature. In fact, such a body will lose heat unless it receives sufficient energy from its surroundings.

As a body increases in size, its surface area becomes increasingly inadequate to allow the radiated energy in its interior to escape without a build up of heat at, and below, the surface. The surface will not radiate the

heat or energy outwards as quickly as it is created in the interior. The rate at which energy is radiated from a surface increases rapidly with a resulting increase in surface temperature. This varies as the fourth power of its absolute temperature. For example, within a certain temperature range, if the temperature is doubled, the rate at which energy is radiated in the form of photons and soft particles, increases by a factor of 16.

The critical size of such a body will depend on its composition. For example, if it contains a high concentration of mildly radioactive substances, this critical size will be less. If the body is hollow, then the dimensions would have to be greater. The red giants, if they are even close to the dimensions claimed, would have to be hollow and have relatively thin shells, otherwise, they would not be red as their surface temperatures would be astronomical.

The actual source of the energy which is finally radiated out into space is the soft particles and photons which are normally radiated by the atoms of the material inside a sun. This is due to the activities of the fundamental particles. Because of the great mass of a sun, an abnormal concentration of these soft particles is always present in the interior. This concentration is greatest near the surface. There is a steady increase in intensity, from the centre toward the outside. This results in a continuous disintegration of a high percentage of those particles near the surface, accompanied by a great increase in temperature, which in turn, results in a greater rate of disintegration, with the release of harder particles which produce the higher temperatures. At the same time, there is an increase in the rate at which the soft particles are created. The temperature will decrease steadily as the centre is approached and any sun will have a relatively cool interior.

The principle that size is the major factor in a celestial body's ability to radiate is confirmed by the behaviour of very large planets such as Jupiter and Saturn. An application of this principle indicates that bodies of such size should start radiating more energy than they receive from outside sources. Recent determinations indicate that Jupiter and Saturn do, in fact, radiate more energy than they seem to receive from the Sun. A probe showed a surprisingly higher temperature in Jupiter's upper atmosphere than was formerly believed to exist.

It now becomes apparent that the conventional theory which states that the radiant energy of the Sun is produced by thermonuclear reactions is complete nonsense. One thing to consider is that if this were the case, the Sun's radiation would be so lethal that no life could exist on any of the planets in the solar system.

Occasionally, throughout the universe, the gradual build up of heat in the interior of suns becomes very much greater, possibly due to the quantity of radioactive elements in the interior caused by transmutation. In such cases, relief valves in the form of sunspots, no longer take care of the excess energy increases and large portions blow apart, releasing astronomical quantities of radiation. After the explosion, the supernova becomes a burnt out body in comparison to its former state. Considering the countless billions of stars within our field of vision, and since only a few supernovas have been observed down through history, it is logical to conclude that it is not the fate of the great majority of stars.

One of the phenomena concerning the Sun, which completely baffles all of the scientists, is that it seems to rotate faster at the equator than it does in the higher latitudes. Sunspots in the vicinity of the equator make a revolution about the Sun in less time than those in the higher latitudes. This is an annoying paradox which can't be pushed aside by these scientists as it is out there for all to observe.

The part of the Sun which we see is a highly fluidic blanket. The region around the Sun's equator could rotate faster if, and only if, a steady external pull is exerted on that region. Otherwise, internal friction would eventually produce a uniform motion. This means that bodies in orbit near the equator and close to the surface, are generating a high concentration of gravity-inducing radiations. It becomes evident that such bodies could not consist of normal matter and are probably composed of atoms and molecules made up of softer particles which are little affected by the Sun's radiation. Such bodies could generate a concentration of gravity radiations considerably out of proportion to their masses. Being constructed of this kind of material, they would be practically invisible.

23. Errors have been made in determining the size and distance of planetary bodies. Charles Fort cited many instances of fiascos which belied astronomers' claims of extreme accuracy in determining stellar and astronomical distances. His revelations did little to enhance their reputations as paragons of integrity.

The principles employed by astronomers in their measurements are essentially the same as those used by surveyors in measuring distances and elevations. However, some surveyors admit that they are unable to determine the height of mountains with any degree of precision and their measurements may be off by as much as 10%. Mr Cater has tested this using an altimeter which was set to zero at sea level and then driven

to the top of a mountain at $42^{\circ} 30'$ North latitude, which is supposed to have an elevation of 9,269 feet. The altimeter reading agreed closely with the established elevations of towns along the route ranging from 1,000 to over 4,000 feet. However, at the top of the mountain, the reading was only 8,800 feet. Mr Cater then reset the altimeter to the 9,269 feet attributed to the mountain and retraced his route. At every spot on the return trip, the altimeter consistently indicated elevations more than 400 feet higher than before. Even after several months, the altimeter reading was still more than 400 feet higher than it should be. A similar test was carried out on a mountain with a recorded elevation of 4,078 feet and at the top, the altimeter showed 3,750 feet although it agreed with other established elevations much lower down.

The fact that the altimeter was accurate at all places except the top of the mountain (whose official height was found by triangulation) shows that the methods employed by surveyors and astronomers are far from being accurate. The heights of mountains determined by triangulation will always be considerably more than the true value. There are two factors involved. First, the atmosphere becomes steadily denser as one descends from the top of the mountain. Second, the orgone concentration becomes greater closer to the ground. This means that light rays from a mountain top will be refracted and so appear to be originating from a point well above the top of the mountain. This was also confirmed by a barometric test at the top of Mount Everest which indicates that it is actually 27,500 feet in elevation and not the 29,000 feet previously supposed.

A friend of Mr Cater had his property surveyed to determine the acreage. Afterwards, he checked some of the distances determined by triangulation, using a tape measure, and found significant errors. Refraction of light is clearly throwing triangulation results off. The bulk of refraction effects are caused by orgone concentration. The measurement of mountain elevations taken at different times give different values and this is due to fluctuations in orgone concentrations, which are higher on hot sunny days than on cool cloudy days. Also, they are generally higher during summer months rather than at other times of the year.

The examples above show the unreliability of results obtained by triangulation. Astronomers are faced with additional factors when they try to apply triangulation, such as the Van Allen Radiation Belt, varying concentrations of orgone throughout space, etc. It is not realistic to assume that astronomers can determine planetary and astronomical distances with great precision.

There are several factors which astrophysicists and astronomers have not taken into consideration in their calculations. Perhaps the most important of these is the fact that all electromagnetic radiations including gravity in free space, suffer an attenuation effect which is well above that of the inverse square law. Everywhere in the universe is permeated with soft and hard particles of all kinds. These particles have been radiated by planetary systems for countless ages. This principle is demonstrated by fluctuations in the velocity of light and gravity attenuation.

There is a steady decline in the velocity of light as it travels through space. The reasons for this can be seen from the following considerations. Normal light, or light which has travelled a relatively short distance from its source, immediately resumes its original velocity after passing through a dense medium such as glass or water. As shown earlier, this is due to the close bunching of photons and soft electrons in any given ray. The concentrations of particles in a ray of light tends to decrease after travelling great distances. The farther it travels, the more attenuated the ray becomes. This means that its ability to increase its velocity after passing from a medium of a given density to one of a lesser density, will be reduced. This is, of course, due to the scattering and dissipation of particles within the ray as it encounters the conglomeration of particles moving in random directions throughout space.

Since conglomerations of soft particles permeate all known space, and the distribution is not uniform, it follows that light will experience refraction effects, even when passing through free space. Therefore, even under the best conditions, with observations being made beyond the atmosphere, astronomical observations cannot be made with any degree of accuracy. The difficulty is, of course, compounded when the observations are made inside the atmosphere. It is small wonder that Charles Fort found a wealth of evidence that completely debunked the astronomer's claims of great precision.

The fluctuation in soft particle distribution, along with the refraction effects of the atmosphere, rules out the possibility of averaging out errors by making many observations and applying the mathematical method of least squares. Conventional statistical theory obliterates actual small variations and distorts data by such averaging out processes. The gross errors which crop up despite these methods speak for themselves.

In order to measure the orbital distance of various planets, it was necessary to find the distance of the Earth from the Sun. Originally, this was allegedly found by measuring the angles that two widely separated observation points on the Earth made with the Sun. This is known as the parallax method. The distance to

the Sun was calculated from these angles and the distance between the observation points. The size of the Sun could then be determined, and knowing the orbital period of the Earth around the Sun, the Sun's mass and surface gravity were calculated by applying the false Newtonian concept of gravitation.

More recently, the distance to the Sun, known as the "astronomical unit" was supposedly determined to a high degree of "precision" by measuring the distance of the body Eros by the parallax method when it was closest to the Earth. Knowing the period of Eros' orbit, the distance to the Sun was calculated by the use of Kepler's law which states that "the square of the periods of any two planets are proportional to the cube of their mean distances from the Sun". Since the orbital periods of the planets are known to a reasonable degree of accuracy, most of the other unknowns within the solar system could be calculated by knowledge of the Sun's alleged mass and surface gravity. By now, it should be apparent that it would be a miracle, or at least, one of the strangest coincidences ever, if the actual distances coincided even approximately with the calculated values.

If the Newtonian concept were valid and the planets were held in orbit by only the effects of the Sun's surface gravity, then the orbital periods of the planets would be a reliable means of determining planetary distances. Since it has been proven that the concepts on which these calculations were made are false, it can be safely concluded that the size of the orbits is considerably different from what the astronomers claim. As a result of the dissipation effects of radiation, well beyond that which can be expected from the inverse square law, it follows that planetary distances are very much different from the accepted values.

This excessive attenuation of the gravity effects of the Sun is reflected in the alleged rapid increase of orbital distances of the outer planets. The supposed orbital distances are as follows:

Earth:	1.0 astronomical units.
Mars:	1.52 (difference 0.52)
The asteroids:	2.76 (difference 1.24)
Jupiter:	5.2 (difference 2.44)
Saturn:	9.58 (difference 4.38)
Uranus	19.16 (difference 9.68) and
Neptune	30.24 (difference 11.08)

It does not follow that the longer the orbital period, the greater the planetary distance. For example, within certain limits, the larger and more massive the planet is beyond a certain critical amount, the slower it must move in order to stay in a given orbit. This is because the total gravity effects of the Sun are unable to permeate and affect the entire mass to the extent that they would with a smaller planet. For example, a planet like Saturn could be placed in a stable orbit inside Earth's orbit. Yet it would have to move so slowly in it's orbit that it's orbital period would be much greater than that of Earth. This means that orbital periods are not a reliable gauge for relative orbital distances.

Although planetary and stellar distances are completely unknown as far as astronomers are concerned, and at this time there are no reliable means available of determining them, the diameters of some of the inner planets, including Jupiter and Saturn, can be calculated far more accurately than any of the other values in the realm of astronomy. The orbital distances of the planetary satellites in proportion to planetary diameters as well as their periods can be accurately determined. The determination of these constants is not affected to any significant degree by the dissipating factors of light already mentioned since a planet and it's satellites are about the same distance from the Earth. The main factor which makes it possible to approximate the diameter of any of these planets is the knowledge that they have practically the same surface gravity as Earth does.

If a satellite is very small as is the case with the satellites of Mars, a planetary diameter can be calculated with a high degree of accuracy. In fact, Mars is the only planet in the solar system whose diameter can be reliably determined. Astonishingly, Mars turns out to have a diameter of about 11,300 miles. Using unusual methods, Mr Cater has estimated the diameter of the Sun as over 2,500,000 miles and at a distance of about 277,000,000 miles from Earth. The Moon diameter at 5,200 miles at an average distance of 578,000 miles, shell thickness 115 miles and surface gravity 98% that of Earth. With a lesser degree of accuracy, the diameter of Venus is assessed at 23,000 miles and Mercury at over 8,000 miles. Jupiter diameter about 230,000 miles and Saturn about 200,000 miles. It is most unlikely that the accepted distances to the stars are even approximately correct.

24. Hard electrons travel through metals more readily than through non-metals. This indicates that they encounter more extensive positive electrostatic fields between atoms and molecules than in non-metals. At the same time, the atoms in metals are usually more mobile or free to move around than is the case with

solid non-metals. This is why the best conductors of electricity are also the best conductors of heat. It is significant that all of the heavier atoms are metals, with the exception of radon which is a gas. This means that such atoms have a higher net positive charge, which causes a stronger mutual repulsion for greater distances on atoms which are not directly connected to each other. This greater extension of the positive zone around such atoms gives them more freedom without breaking the bond which holds them together. The repulsive forces of nearby atoms, increases the mobility of any given atom.

The heavier atoms contain more protons and neutrons bunched together. The outside pressure needed to hold a group of mutually repulsive particles together is independent of the number of particles present.

One might conclude that the heaviest atoms make the best conductors, but this is not the case. Silver, copper and aluminium are the best conductors although their positive field zones are not as extensive, they have less inertia and so are more easily pushed out of the path of a flow of hard electrons. Electrons which flow along conductors are continually colliding with atoms in motion. Therefore, it require a steady application of electromotive force at the ends of the conductor in order to keep them flowing. The atoms of non-metals are more firmly locked into position and therefore do not have that much of a tendency to move out of the way and this is why they make good insulators. Electrons follow the lines of least resistance and so they tend to move on the surface of the conductor where there is less tendency to collide with atoms.

The rules governing the conductivity of soft electrons are somewhat different from those of hard electrons. Soft electrons are enormous when compared to hard electrons. This can be seen when considering that the average diameter of a particle is directly proportional to it's so-called wavelength of the light comprising it (or inversely proportional to the frequency). The ethers associated with atoms and their fundamental particles are much higher in frequency than those associated with soft particles. This means that atoms will offer little resistance to the passage of soft electrons. However, the magnetic fields resulting from thermal agitation of certain atoms and molecules are involved with ethers which are closer in frequency to the ethers directly associated with soft electrons. Consequently, soft electrons will interact with these fields. This explains why metals in general offer greater resistance to the passage of soft electrons than do non-metals.

The ordinary electrical transformer presents an enigma. The secondary of the transformer continues to pour out or eject electrons from a seemingly unlimited source. There is a limited quantity of free electrons in conductors which should be exhausted quite quickly. The standard argument used to account for the source of current is that free electrons in the circuit supply the electrons and are used over and over again. A simple calculation demonstrates that free electrons in conductors are not the source of electricity.

Consider a wire two millimetres in diameter which carries about 10 amps of current. The electron flow is concentrated near the surface of the wire. Since the electricity in a conductor travels at about the speed of light, such a wire 186,000 miles long would have 10 coulombs of electricity distributed over it's surface at any instant. The surface area of this wire is 1,840,000 square metres. A parallel plate capacitor having this plate area and a separation of one millimetre, would have a capacity of 0.016 farads. Even with a potential across it's plates of 100 volts, it would still only be able to concentrate an equivalent of 1.6 coulombs, and a good part of this electrostatic charge would be due to the displacement of the electrons and protons of the atoms. This voltage is more than enough to concentrate all of the free electrons on the surface of the plates. Similarly, all of the free electrons in the wire example would be involved if the current were maintained with 100 volts. Of course, a wire this long would have too much resistance to carry any appreciable current with 100 volts, but this has nothing to do with the argument just given. As a matter of fact, even 6 volts is far more than enough to produce a current of 10 amps in a wire of 2 mm diameter. Therefore, there aren't enough free electrons in any conductor to supply any appreciable current. This means that the source of electrons in current flow is not coming from free electrons in the conductor. The conclusion is therefore that the hard electrons somehow manage to get through the insulation of the conductor and flow into the wire from outside.

By the law of action and reaction, since a current has inertia, any change in the primary current of a transformer produces a force in the opposite direction in the secondary. This reactive force produces a disturbance of the ethers which produce the voltage or Electromotive Force as a result of increased ether bombardment. The EMF induced in the secondary winding of the transformer, creates a temporary electric void in the wire which draws all kinds of negative charges to the wire. The softer electrons quickly penetrate the insulation and stop at the surface of the wire as they do not travel as readily through a hard electron conductor. These softer electrons absorb most of the electrostatic forces in the insulation which impede the flow of hard electrons, allowing the hard electrons to pass through the insulation and enter the wire.

Electrical charges, composed of photons in nearly all the frequency ranges, permeate all space, since they are continually radiated by stars throughout the universe. They are no easily detected as they are in the

form of conglomerates with the harder particles residing inside the softer ones. The resulting combinations are highly penetrating and it takes something like a voltage induced in a conductor to separate the harder particles from the softer ones. The performance of a transformer can be greatly impaired by completely shielding the secondary winding with a good conductor of electricity such as copper or pure aluminium. This is because the shield tends to impede the flow of soft particles to the secondary. This effect has been verified by experiment.

The terms "EMF" and "voltage" need clarification. The true nature of the phenomena associated with these terms has never been fully understood. All that has been known is that if a conductor is exposed to an EMF, a flow of electricity is produced. Also, voltage is associated with the amount of energy or work which a current is capable of producing. An EMF of a given value can induce a current with a definite voltage. The voltage produced is directly proportional to the EMF impressed on the conductor. Also, the energy of the current is directly proportional to the voltage. The amperage of a current is a measure of the number of electrons passing through each segment of a conductor per second. Since wattage, or the total kinetic energy of this current flow is equal to the amperage multiplied by the voltage, it follows that the amperage is also directly proportional to the energy of the current flow. Therefore, Voltage is a measure of the average kinetic energy of the electrons flowing along the conductor. This in turn, is directly proportional to the square of the average velocity of the electrons. This simple definition of voltage is sadly lacking in all standard textbooks.

An EMF induces an accelerating force on an electron. What is the nature of this force? Basically, there are two methods of producing an EMF. One is by subjecting the conductor to a fluctuating magnetic field, and the other is by exposing the conductor to a difference of potential, such as connecting it between the opposite poles of a battery. In that instance, one battery pole has a negative charge while the opposite pole is positive. The flow of electrons is the result of an electron concentration at one point tending to flow to an area where there is a shortage.

The EMF is produced by direct electrostatic force, which in turn, has a dual nature. There is the tendency for negative charges to be attracted to positive charges, and then there is also the mutual repulsion between negative charges. The voltage attained is directly proportional to the difference of potential existing between the poles of that battery. The difference of potential is equal to the kinetic energy gained by the electrons in moving from one potential to the other.

The EMF produced by a fluctuating magnetic field gives the same results but the process is different. When a conductor is subjected to a fluctuating magnetic field, as with the secondary winding of a transformer, the "free" electrons of the conductor and the outer electrons of the atoms which are not as intimately associated with the atoms, are exposed to differential ether bombardments. It is equivalent to an electrostatic force. When a magnetic field changes, the change does not take place simultaneously throughout that volume of space occupied by the field but it progresses from one portion to another. This creates differential electrostatic ether particle bombardments on electrons within the field. When a conductor cuts magnetic lines as with an AC generator, the electrons are subjected to the same conditions experienced by electrons moving between the poles of a magnet. The accelerating force will be in a direction perpendicular to the direction in which the electrons in the conductor are found to move.

If there were even a small fraction of the free electrons existing in the matter as is believed by our physicists, the negative charge effects of matter would be so great that these bodies would be unable to get close to each other. Much of the charge on capacitors comes from outside the capacitor, as is the case with the flow of electricity in conductors. Actually, free electrons in a conductor are practically non-existent. Hard electrons which are not a part of the atoms are captured by soft particles which permeate matter. The soft particles release hard electrons when subjected to the EMF in a current, or the voltage across the plates of a capacitor.

The current in a straight wire is evenly distributed along the surface where the electron flow encounters the least resistance. The released hard electrons which are directly affected by the EMF, tend to move as a unit partially held together by mutual magnetic attraction. This unit leaves a temporary void behind it which is quickly filled by surrounding hard electrons. Many such groups are started almost simultaneously in a conductor at about the speed of light, although the electrons themselves travel at a much lower velocity. When an EMF is applied to a conductor, something akin to the domino effect is set up in the ethers. This effect travels at the speed of light since it is produced in a similar manner.

That the source of electricity flowing in power lines as well as that produced by generators, comes from soft particles which permeate and surround the area, has been proven during auroral displays. When aurora activity is unusually high, transformers in Canada have been known to burn out and even explode. At the

same time, increase of current flow in power lines has been great enough to trip circuit breakers as far south as Texas. As explained earlier, the concentration of soft electrons in the atmosphere is greatly increased during auroral phenomena. Some areas receive higher concentrations than others at the same latitude.

A loop of wire or a coil offers impedance to alternating current. This property is known as "inductance". Since a single loop of wire has inductance, it follows that the effect can be explained in terms of one loop. Electrons tend to travel along the surface of a conductor as that is the path of least resistance. The major source of this electricity is the high concentration of soft electrons which gather around a conductor and permeate the material. This is due to the relatively high positive charge of the conductor. The greatest concentration is found at the surface and a short distance below the surface. When an EMF is applied to the conductor, free electrons are set in motion. During this process, soft electrons concentrated at and just below the surface tend to disintegrate and release more hard electrons. This is enhanced by the concentration of the soft electrons, which in turn causes an agitation of the soft particles, causing them to become highly unstable.

In a straight wire, most of this disintegration and nearly all of the electron flow takes place below the surface. This condition greatly shortens the mean free path of the electrons and the flow stops immediately after the applied EMF is shut off. Consequently, an alternating current will encounter the same ohmic resistance in a straight wire as will a direct current. However, the situation is different when the conductor is looped.

When an EMF is applied to a loop, the free or released hard electrons below the surface are forced to the outside by centrifugal force, whence a still greater disintegration of soft electrons occurs because the greatest concentration is at the surface. The mean free path of the electrons is greatly increased and the flow continues for a brief period after the EMF travelling in the direction of the current flow ceases. When the EMF continues in the opposite direction as in the case of an alternating current, the force must oppose the momentum of the electron flow still continuing in the opposite direction to that of the new EMF direction. It follows that this impedance will be directly proportional to the number of turns and to the frequency of the AC. It is logical to assume that the deceleration rate of the electron flow is a constant when the EMF is zero. This means that the more quickly that the EMF is applied in the opposite direction, the higher the velocity of flow that will be encountered. It will be a linear function.

It would now seem evident that when the AC is rectified or has been changed to a pulsed DC, the coil will produce an increase in amperage where a straight wire will not. Experiments have confirmed this. It was found that the input amperage of a current was greatly increased after it passed through a coil. The increase was greatest during the initial stage of the applied EMF and soon dropped to a lower value as the concentration of soft electrons around the wire was reduced. It follows that a coil will offer impedance only to an AC current. It follows that pulsed DC has numerous advantages over AC. It can be used to operate transformers as well as AC without suffering impedance.

A steady direct current experiences the same resistance in a coil as it does in a straight wire of the same length. The fluctuating EMF produces extreme agitation of the soft electrons around and inside the wire, resulting in the disintegration of a large percentage of them, and the release of a high concentration of hard electrons. This does not occur during the steady flow of direct current. During the initial application of DC there is a surge of additional current during the build-up of the EMF. When the current is shut off, there will be a momentary surge of current in the opposite direction. The excess of electrons on the surface of the conductor and in the coil will naturally flow towards the void outside the coil and in the opposite direction to which the current was flowing. The concepts just outlined can be applied when building a self-sustaining electric generator.

When an alternating current is applied to a coil, the EMF must overcome the impedance each time the EMF changes direction. The greatest amount of resistance occurs at the beginning of each change and then steadily decreases as the current builds up. The resistance will be at a minimum when the current reaches it's maximum. With AC, the EMF changes direction very frequently and so the maximum resistance is encountered for a high percentage of the time.

The flow of electrons in a wire results in a circular magnetic flow around that wire. As mentioned previously, the magnetic effects between electrons moving together tend to cancel each other out. They are drawn together and the resulting ethers encompass the entire group. This also occurs between adjacent wire segments in a coil. The magnetic effects are cancelled out between the segments and a continuous ether flow, encompassing the entire coil, perpendicular to the direction of the current flow, will occur. The solenoid will then behave like a bar magnet with continuous lines of force.

The Earth's atmosphere produces geomagnetism in much the same way that a solenoid produces a

magnetic field. Changes in the atmosphere move along with the Earth in a circular motion. Although there is little motion of the charges relative to the surface, a magnetic field is still created. Magnetic lines, or ethers, flow from the South magnetic region to the North magnetic region as a result of these rotating charges.

25. Despite the fact that our illustrious physicists have managed to develop as highly a destructive device as a nuclear bomb, they still have no concept of the nature and source of the energy released after a detonation. As with all other well-known phenomena, they try to create the illusion that they comprehend and have explained it. As a matter of fact, academic science has not yet supplied satisfactory explanations for any of the simplest and most common everyday phenomena. The energy released by nuclear devices is explained away by stating that it is a conversion of matter into energy in accordance with the false Einstein relation $E = mc^2$. Many readers, especially those steeped in orthodoxy, may be shocked to learn there is no conversion of mass into energy during such a process, nor by any process in which energy is released! The tremendous heat produced in a nuclear blast means that an abnormal quantity of hard electrons were suddenly released by the complete disintegration of all the soft electrons within the area of the explosion. The intense light that accompanies the blast is the result of the photons set free by the disintegration of those soft electrons.

The key to the triggering of the reaction is the neutron. As indicated earlier, a neutron is equivalent to a collapsed hydrogen atom, and yet it is more than this. A hydrogen atom has a strong net positive charge, while the neutron has no net charge. This means that a neutron has collected far more hard electrons than a hydrogen atom. Since a neutron has no charge, it cannot add to the weight of an atom, as is commonly believed.

The concepts introduced in this treatise render all of the old beliefs concerning atomic structure invalid. The weight of an atom is dependent almost entirely on the number of orbital electrons and the number of protons in its nucleus. This will be discussed in more detail later. There is an exception or two to the above rule in the case of certain radioactive elements where the presence of neutrons can actually reduce the weight of an atom. An interchange of excess electrons between protons and neutrons within the nucleus, and thus transformations of protons into neutrons and vice versa, can occur. The neutrons greatly outnumber the protons in the heavier atoms, especially those that are radioactive. During the interchanges between neutrons and protons, excess neutrons disintegrate into protons and hard electrons are ejected from some of the atoms. This results in a transformation of such atoms. Simultaneously, the tremendous interactions between electrons released in this manner as well as from the disintegration of soft electrons in the vicinity cause the higher ethers to be disturbed, ultimately resulting in the production of gamma rays.

The isotope of the more common uranium 238 atom known as U235 is lighter yet it is fissionable and more radioactive than the uranium 238. It is lighter because it supposedly has fewer neutrons than the ordinary uranium atom. The opposite is actually the case. The U235 having more neutrons is more radioactive. The greater interactions within the nucleus result in more hard electrons being released, which reduces the overall positive charge of its nucleus.

There is a continuous interchange of ejected protons transforming back into neutrons and vice versa among the U235 atoms. A similar but less violent interchange takes place among the atoms of U238. A low percentage of the U238 atoms receive more than their share of these interchanges and thus transform into U235 atoms. Most of the hard electrons released which contribute to such interchanges and transformations is the result of the disintegration of soft electrons which permeate the atoms. It follows that the main contributing factor of radioactivity is the presence of soft electrons which house the hard electrons! Therefore, if the soft electron concentration throughout the vicinity of a radioactive substance is reduced, it will lose much of its radioactivity. By now, it has no doubt occurred to the reader, that a Reich cloud-buster pointed at a radioactive material would cause it to lose its radioactivity! This has been proven to be the case. For example, a glowing piece of radium stops radiating when it is placed in front of a cloud-buster.

The source of the energy released during a nuclear blast is now becoming clear. When a fissionable material like U235 or plutonium is bombarded with additional neutrons, the increased activity in the nuclei causes even the most stable soft electrons in the vicinity to disintegrate. A chain reaction of soft electron disintegration in areas well beyond the confines of the fissionable material results. All of the hard electrons and protons originally camouflaged by the soft particles are suddenly released. A tremendous gamma ray production also occurs. Adequate quantities of fissionable materials suddenly brought together can result in a sufficient increase of neutron bombardment of the interior atoms to produce such a result. It is known as the 'critical mass'. The proper fusion of hydrogen atoms can also cause enough soft electron disintegration to produce a similar result. It is now apparent there is no conversion of mass into energy during the process. All of the fundamental particles of the atoms involved remain intact. In fact, there is even more mass following a blast than there was previously, as a result of the additional hard electrons and protons released.

Once again, it is obvious that the Theory of Relativity is in no way concerned.

The monstrous hoax fostered on the public by the Defence Department of the Government, now becomes more than obvious. A Reich cloud-buster can completely deactivate nuclear devices for great distances by drawing away the soft electron concentration from the vicinity of such device. In fact, a cloud-buster can be used for downing fleets of planes carrying nuclear weapons. Combustion is also dependent on soft electron concentrations which of course includes jet engines. Therefore jet engines or missiles cannot function in an area affected by a cloud-buster. The fact that a simple cloud-buster can deactivate a nuclear reactor from a great distance has been proven on numerous occasions. For example, during the time Reich was carrying out intensive experiments with a cloud-buster in Arizona in the early 1950s, a large reactor several hundred miles to the southeast quit functioning. This means that hundreds of billions of tax dollars are being funnelled every year to support a multibillion dollar nuclear industry and other related industries which are rendered obsolete by the device used by Reich.

It is evident that the proper use of the cloud-buster could throw modern warfare back to the stone age. Obviously the drawing of soft particles away from any group would completely enervate each individual and even turn him into a block of frozen flesh. Although a cloud-buster could not completely deactivate a particle beam weapon it could bring down any craft carrying such a device before it could get into position. The potential of the cloud-buster is perhaps greater than even Reich himself realised. Since heat is transferred from one body to another by soft electrons which release harder electrons, the cloud-buster can be used as a highly efficient refrigeration system by drawing soft electrons away from a body. It has been made apparent that this simple device can render present fire fighting techniques obsolete. By use of the cloud-buster in the proper manner, the loss of life and property from fire and storms could become a thing of the past. It also provides dramatic proof of the validity of many of the new concepts introduced in this treatise.

Radioactivity was the subject of a ridiculous, if not amusing, fiasco more than two decades ago when two physicists, Lee and Yang, received the Nobel Prize in 1957. The incident, which was given wide publicity, concerned an error in the parity principle. The parity principle has been defined as "a mathematical concept impossible to define in physical terms". How such a concept could have any bearing on physical reality is not made clear. Generally, anything relating to reality can be defined in terms of reality, which is in conformity with the Law of Cause and Effect.

Incredibly, an experiment was devised to test the validity of this great revelation. It was based on the idea that a radioactive substance should eject more particles in one preferred direction, than in any other. Radioactive cobalt was chosen. It was cooled down to near absolute zero and exposed to a powerful magnetic field produced by a solenoid, in order to align the nuclei. Another physicist, a Dr. Wu, had devoted six months of hard work setting up the experiment. Indeed, it was found that more particles were ejected out of one pole of the solenoid than the other. Which pole was it? Of course, it was the pole out of which the magnetic lines flowed. Naturally, the experiment merely demonstrated that particles tend to travel down magnetic lines of force. The excess of particles that came out of the pole were those barely ejected from the atom. They had such a low initial velocity that, regardless of what direction they happened to be travelling initially, the magnetic field would dictate their final direction of travel.

Lee and Yang were accorded every scientific honour, including the Nobel Prize, as a result of this experiment. Instead of giving them the Nobel Prize, the awarding of an Oscar would have been more appropriate. Accompanying the extensive publicity given this comedy act was a photo appearing in a prominent magazine showing one of the recipients pointing to a grotesque mathematical equation containing over 100 terms! He was allegedly explaining the reasoning behind their great revelation.

The great nuclear scare scam should rate as the biggest lie of the century. This fabrication is so colossal even Mr Cater is somewhat embarrassed to admit he was also taken in by it, as everyone else was, except those directly involved in the conspiracy but Mr Cater never questioned it as he had other universally accepted beliefs. The long-hidden truth is this: radiation from radioactive substances is relatively harmless! One can actually swim in water from so-called high level nuclear waste, drink the water and actually thrive on it. Also one can handle pure U235 and even plutonium (the fuel for A-bombs) with bare hands all day long, and suffer no ill effects. Of course excessive exposure to this radiation can be inimical, as can occur from any other type of radiation such as sunlight. The effects, however, are immediate and not long-lasting if the source of the trouble is removed. The popular belief that mutations can result from this radiation that effects future generations, is complete nonsense. A study of the effects on the victims of Hiroshima and Nagasaki bear this out. The only mutations are immediate damage to cells and subsequent malfunctions from ultra-high concentrations.

For the above revelations we are indebted to a courageous and dedicated individual who worked for 35 years in the nuclear industry. He was intimately involved in every aspect of the production of nuclear fuels and the building of reactors. He is Galen Windsor, of Richland, Washington. The so-called lethal nuclear radiations are relatively harmless, with very limited penetration. In 1987, Galen had already lectured in 77 different cities over a two-year period. His credentials are impressive. He has worked in every major reactor decommissioning project in America. He was involved in the analytical process inventory control, which was responsible for measuring and controlling the nuclear fuel inventory for these projects. He has few peers in this field and all of them agree with him but are afraid to speak out. He is one of the world's greatest authorities of nuclear radiation measurement.

He and others did plutonium processing using their bare hands until radiation monitors were installed at every reactor. Rules were laid down as to the amount of exposure to radiation that must not be exceeded. If the rules were not followed, the worker disappeared and was never seen again by anyone. The reason is obvious. If word leaked out that radioactive materials below critical mass were harmless, then there would be widespread pilfering of such products. The lie that radioactive materials can be handled only with extreme safety precautions must be maintained at all costs. The high-level disposal act of 1982 calls for the permanent disposal of the so-called high level waste 3,000 feet underground. This high level waste consists of reusable uranium fuel and contains useful metal isotopes. Every ton of it is worth about 10 million US dollars.

Enough has been collected to pay off the National Debt. Portland General Electric owns the Trojan reactor and had a storage basin problem. Windsor offered to take all of their spent fuel off their hands. He would ship it, store it, and do everything that needed to be done at no expense to them, if they would give it to him. They told him "Go to Hell, Galen Windsor - we value it more than plutonium or gold. We are going to play the plutonium future ourselves".

Windsor was taken to California in 1965 to help design and build a nuclear fuel reprocessing plant. After it was built in 1973, a presidential order was issued which said the plant was not to be run. At that time, they had 170 metric tons of spent fuel stored in the basin. Also, the maximum allowed exposure was further reduced by a factor of 10. This was the beginning of Windsor's rebellion against "The Establishment". He began swimming in a 660,000 gallon pool containing the spent fuel. The radioactive materials it contained were enough to maintain a water temperature of 100° F and the water would glow with a bluish light in the dark. He discovered that the tank provided good drinking water.

Windsor was also asked about what was in the burial sites of so-called low-level nuclear waste. The answer was that there are no nuclear wastes, only materials produced in a reactor to be recovered and used beneficially. Low-level waste is an excuse for a Federally-mandated non-inspectable disposal system, so that organised crime can get rid of any evidence they want, and that it can never be dug up again. Also, so that no one finds out whose bodies are in those drums. This is what is contained in barrels that are dropped in the ocean.

Windsor also stated, (and he was in a position to know), that in 1947 the United States sent to the USSR all the necessary materials and technology to build A-bombs! This was under the approval of President Truman. In 1949, they exploded their first A-bomb. Later, the Rosenbergs were executed for allegedly turning over nuclear "secrets" to the Russians.

According to Windsor, by 1975 large reactors no longer had a future. They are being phased out. The notorious Three-Mile Island incident was no accident. It did no damage and no one was harmed. But, it did impress upon the public the alleged danger of reactors. Windsor advocated the use of many small reactors systematically distributed. They could be not only used for producing adequate quantities of electricity, but for obviating refrigeration of packaged foods. When briefly exposed to the radiation from such reactors they will keep indefinitely. A Federal energy cartel is the reason that the effective use of many smaller reactors is not implemented. They control the amount of electricity, the availability and the price. Windsor stated that no reactors have been built correctly. In any event, reactors can in no way, match the use of self-sustaining electric generators for electricity, but their use in preserving food is intriguing.

From the above, it becomes obvious that recent publicity concerning the danger of radon gas in homes is another monstrous hoax! It could be mixed with oxygen in sizeable quantities and breathed for long periods without damage.

The question now arising is why are the radiations from radioactive sources relatively harmless? Three types of radiation emanate from them: alpha, beta and gamma rays. Alpha rays consist of helium nuclei or a small group of protons, neutrons and electrons. The number of neutrons and protons are still unknown

despite the vaunted claims of nuclear physicists. Since they are totally ignorant as to their true nature, the nature of gravity and soft particle physics, they have no means of determining such values. Beta particles are the hard electrons of ordinary electricity, and gamma rays are negative charges comprised of ether particles in the same range as that of hard electrons. As such, they have no more penetrating ability than a stream of hard electrons and are no more damaging than the hard electrons when they do penetrate. Since they are comprised of the same ethers as atoms and molecules, it follows that they will not penetrate matter as readily as softer particles. This leaves the alpha rays. It has already been shown that positive charges are inimical to living tissues since they tend to absorb the negative charges living organisms require. However, alpha particles also have little penetrating ability for the same reasons as given above, and quickly absorb electrons to become harmless helium gas. Windsor gave demonstrations of such facts at his lectures by use of a Geiger counter.

The capture of large quantities of alpha particles by high concentrations of orgone energy is another matter. Reich termed it deadly orgone energy. The orgone enters the body and releases alpha particles throughout vital organs and produces what is known as radiation sickness. Reich and his assistants had this experience. When the source of the trouble was removed they quickly recovered. Occasionally, deadly orgone can remain in the body and at later periods, release the positive charges at various times, thus causing severe after-effects. This problem can be alleviated by treatments inside orgone accumulators or pyramids after being exposed to the deadly orgone. This is what Reich and his helpers did.

Galen Windsor also stated that the bomb dropped on Hiroshima contained 20 pounds of U235. The one exploded over Nagasaki had 2.5 kilograms or about 5 pounds of plutonium. This values were jealously guarded secrets for a long time. Windsor is likely the first one who has dared reveal it to the public. The author was acquainted with the late Stanislaw Ulam, a mathematician who had calculated the critical mass of these elements for bombs while working on the Manhattan project. It was a deep, dark secret and he would have parted with his life before he would reveal anything so sacred. The degree of the hang-up officialdom has on secrecy is of a magnitude difficult to comprehend, and the steps they have taken to insure it is even more mind-boggling. It is so infantile and childish that there are no words in the English language to describe it adequately.

Radioactive substances such as plutonium, produce their own heat and the larger the mass, the higher the temperature of the mass. This follows identically, the same principle by which the Sun generates it's energy or the ratio between mass and surface area. The essential difference is that plutonium can do in a few cubic inches what ordinary matter does in a ball 2,500,000 miles in diameter!

Interestingly enough, Windsor looks about 30 years younger than his chronological age would indicate. He also stated he always sustained a healthy tan from his work with radioactive substances. It is significant that Reich and his assistant had a similar experience in their work with orgone energy. It is clear Windsor and Reich were exposed to the same energies, high concentrations of soft electrons. The constant exposure to high orgone concentrations during his working hours is what has kept Galen Windsor young. Of course the high orgone concentrations was produced by soft electrons clustering around the radioactive substances which produced a constant flow of positive charges.

You may wonder why Windsor and certain others could handle radioactive substances with impunity while others have either died or suffered from serious physical problems after being exposed to the radiation. As mentioned earlier, radioactive materials radiate highly positively charged particles which are extremely inimical. Some are absorbed by soft electrons and become DOR (deadly orgone energy). They can enter the body and remain for long periods before disintegrating and releasing the deadly particles. These particles are very sluggish when compared to negative particles including soft electrons.

The victims of radioactive fallout are not exposed for any significant period to high concentrations of positive charges. Also, the area of exposure is very large; consequently, the Coanda effect does not come into play and there is no rush of orgone energy to alleviate the situation as was the case with Windsor when he was directly exposed to ultra high concentrations of radioactive materials. Any victim of radioactive contamination can be cured by being exposed to high concentrations of orgone for extended periods as was Reich and his assistants after experiencing radioactive sickness. They had received a heavy dose of DOR as mentioned earlier. Being exposed to high concentrations of radioactivity is equivalent to being placed in an orgone accumulator.

This is only a summary of part of Mr Cater's book which has 586 pages. A number of topics are not even mentioned here. Mr Cater also speaks of:

Superconductivity.
The properties of Helium at low temperatures.
Mystery spots on Earth, including the famous Oregon Vortex.
Gravitational anomalies.
The origin of the Van Allen Radiation Belt.
The research of William Reich.
Orgone energy.
The Oranur Experiment.
The Reich Cloud Buster (which is also a weapon of major power).
Atmospheric phenomena.
Three practical Free-Energy devices.
The great potential of crystals in the obtaining of Free-Energy.
The work of Nikola Tesla with Free-Energy.
The Searle Effect and many other topics.

If you wish to buy a copy of his book, it is supposedly available at these two outlets:
<http://www.healthresearchbooks.com/> or in the UK from <http://www.amazon.co.uk>. I have ordered and paid for a copy of this book on three occasions and every time, the supplier claimed to be unable to supply what was advertised for sale

So, having absorbed some of what Mr Cater has to say, do you feel that you have been treated fairly, and that the true scientific details were presented to you as part of your general education?

Patrick Kelly

<http://www.free-energy-info.tuks.nl/>

Chapter 12: Basic Electronics

Introduction

This document is not an in-depth presentation of the subject of electronics. Instead, it is intended to give you sufficient (empirical) knowledge of the subject to be able to understand, design and build simple circuits such as the control circuits used with the 'Free Energy' devices described in the later parts of this eBook.

Disclaimer

This material is provided for information purposes only. Should you decide to attempt construction of some device based on information presented here and injure yourself or any other person, I am not liable in any way. To clarify this; should you construct something in a heavy box and drop it on your toe, I am not liable for any injury you may sustain (you should learn to be more careful). If you attempt to construct some electronic circuit and burn yourself with the soldering iron, I am not liable. Also, I strongly recommend that unless you are expert in electronics, you do not construct any device using, or producing more than 30 Volts - high voltage circuits are extremely dangerous and should be avoided until you gain experience or can obtain the help and supervision of a person experienced in constructing high voltage circuits.

Voltage.

Voltage is the key to understanding electronics. Without voltage, nothing happens in electronics. What is it? Nobody knows. We know how to generate it. We know what it does. We know how to measure it, but nobody knows what it actually is.

It is also called "Electro Motive Force" or "EMF" which is no help whatsoever in knowing *what* it is. That, is roughly equivalent to saying "the thing that pushes is the thing that pushes" - very true but absolutely no help whatsoever. OK, having admitted that we really don't know *what* it is, we can start to say the things we do know about it:

A new battery has a voltage between its terminals. This voltage is said to cause a current to flow through any complete electrical circuit placed across it. The current flowing through the circuit can cause various things to happen such as creating light, creating sound, creating heat, creating magnetism, creating movement, creating sparks, etc., etc.

By using the current caused by a voltage, a device called a 'Voltmeter' can indicate how big the voltage is. The bigger the voltage, the bigger the current and the bigger the display on the voltmeter. The voltmeter can have a numerical display where you read the voltage directly from the display, or it can be an 'analogue' voltmeter where the voltage is shown by the position of a needle on a scale. The size of the voltage is stated in 'Volts' which is a unit of measurement named after the man Volta who introduced voltage to the world (it was always there, we just did not know about it).

Voltages add up if they are connected the same way round, i.e. with the + terminals all facing the same way:

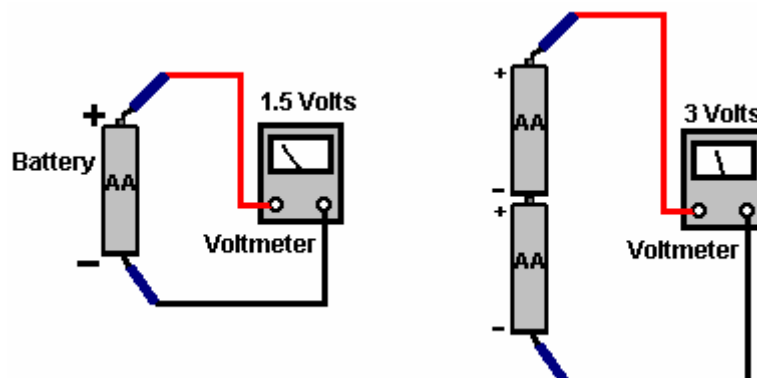

The physical size of the battery usually determines the length of time it can supply any given current - the bigger the battery, the longer it can provide any given current. A battery is constructed from a number of 'cells'. The number of cells in the battery controls the voltage of the battery. For example, an 'AA' size battery (what used to be called a 'penlight' battery) has a single 'cell' and so produces 1.5 Volts when new. The very much larger and heavier 'D' battery also has just one cell and so it also produces 1.5 Volts when new. The difference (apart from the higher cost of the 'D' cell) is that the larger cell can provide a much higher current if both batteries are discharged over the same period of time.

There are several different types of battery construction. A rechargeable NiCad battery has a single cell but its construction method means that it produces about 1.35 Volts when fully charged. In passing, NiCad batteries have a 'memory' characteristic which means that if they are recharged before they are fully discharged, then the next time they are discharged they run out of power at the voltage level it had when the last charging was started. Consequently, it is a good idea to fully discharge a NiCad battery before charging it again.

Car and motorcycle batteries are described as Lead/Acid batteries. This type of construction is not very convenient being large, heavy and potentially corrosive. The big advantages are the ability to provide very high currents and giving 2.0 Volts per cell. These batteries are normally produced as 6 Volt or 12 Volt units. The Amp-Hours for lead/acid car batteries is usually quoted for a 20 hour discharge period, so a fully charged, new, 20 Ahr battery can provide 1 Amp for 20 hours of continuous use. That battery loaded to give 5 Amps, will **not** provide that current for 4 hours but might only last 2 hours, or perhaps a little better. The manufacturers literature should give an indication of the performance, but if it is important, run your own test to see how the battery actually works in practice.

"Mains units" are known in the electronics world as "Power Supply Units" or "PSUs" for short. These convert the mains voltage (220 Volts in UK, 110 Volts in USA) to some convenient low voltage; 12 Volts, 9 Volts, 6 Volts, or whatever is needed. A mains unit can provide several different voltages simultaneously.

Resistance.

Being familiar with Voltage and Resistance is the key to understanding electronic circuitry. Resistance is a measure of how difficult it is for current to flow through something. Some materials such as glass, ceramics, wood and most plastics do not easily carry a current and so are considered to be 'insulators'. That is why you will see power lines hung from their pylons by a series of ceramic discs. Current flows easily through metals, especially along the surface of the metal, so cables are made from metal wires surrounded by a layer of plastic insulation. The higher grade cables have wire cores made up of many small-diameter strands as this increases the surface area of the metal for any given cross-sectional area of the metal core (it also makes the cable more flexible, and generally, more expensive).

There is a very important, third group of materials, silicon and germanium in particular, which fall between conductors and insulators. Not surprisingly, these are called 'semi-conductors' and the amount of current they can carry depends on the electrical conditions in which they are placed. Much, much more about this later on.

While a metal wire carries current very well, it is not perfect at the job and so has some 'resistance' to current flowing through it. The thicker the wire, the lower the resistance. The shorter the wire, the lower the resistance. The first researchers used this characteristic to control the way circuits operated. Sometimes, as higher resistances were needed, the researcher used to need long lengths of wire which would get tangled up. To control the wire, a board with nails along each side was used and the wire wound backwards and forwards across the board like this:

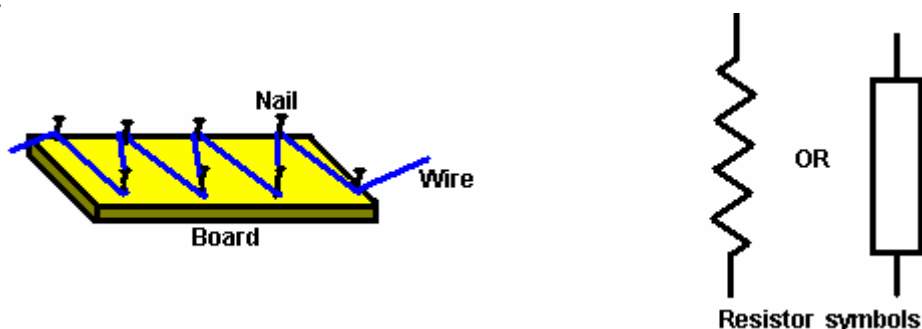

When drawing a circuit diagram, the researcher would sketch the wire on the board giving a zig-zag line which is still used today to represent a 'resistor' although different methods of construction are now used. An alternative symbol for a resistor is a plain rectangle as shown above.

If a resistor is connected across a battery, a circuit is formed and a current flows around the circuit. The current cannot be seen but that does not mean that it is not there. Current is measured in 'Amps' and the instrument used to display it is an 'ammeter'. If we place an ammeter in the circuit, it will show the current flowing around the circuit. In passing, the ammeter itself, has a small resistance and so putting it in the circuit does reduce the current flow around the circuit very slightly. Also shown is a bulb. If the current flowing around the circuit is sufficiently high and the bulb chosen correctly, then the bulb will light up, showing that current is flowing, while the ammeter will indicate exactly how much current is flowing:

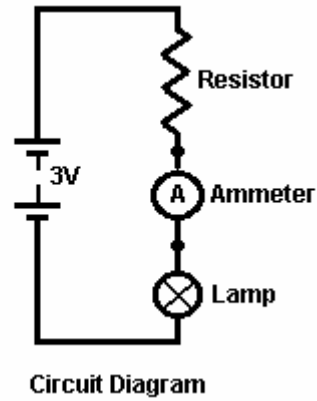
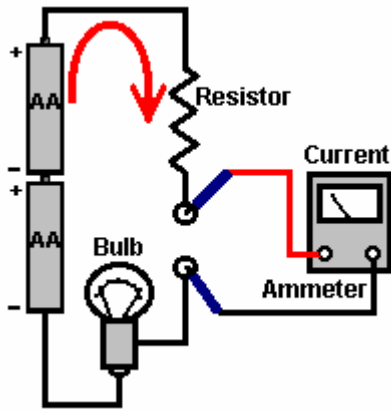

Shown on the right, is the way that this circuit would be shown by an electronics expert (the 'Resistor', 'Ammeter' and 'Lamp' labels would almost certainly not be shown). There are several different styles of drawing circuit diagrams, but they are the same in the basic essentials. One important common feature is that unless there is some very unusual and powerful reason not to do so, every standard style circuit diagram will have the positive voltage line horizontally at the top of the diagram and the negative as a horizontal line at the bottom. These are often referred to as the positive and negative 'rails'. Where possible, the circuit is drawn so that its operation takes place from left to right, i.e. the first action taken by the circuit is on the left and the last action is placed on the right.

Resistors are manufactured in several sizes and varieties. They come in 'fixed' and 'variable' versions. The most commonly used are the 'fixed' carbon 'E12' range. This is a range of values which has 12 resistor values which repeat: 10, 12, 15, 18, 22, 27, 33, 39, 47, 56, 68, 82 and then: 100, 120, 150, 180, 220, 270, 330, 390, 470, 560, 680, 820 and then: 1000, 1200, 1500, 1800, 2200, 2700, 3300, 3900, 4700, 5600, 6800, 8200, etc. etc. Nowadays, circuits often carry very little power and so the resistors can, and are, made in very small physical sizes. The higher the resistance value of a resistor, the less current will flow through it when a voltage is placed across it. As it can be difficult to see printing on small resistors clustered together on a circuit board and surrounded by other larger components, the resistor values are not written on the resistors, instead, the resistors are colour-coded. The unit of measurement for resistors is the 'ohm' which has a very small size. Most resistors which you encounter will be in the range 100 ohms to 1,000,000 ohms. The higher the resistance of any resistor, the smaller the current which will flow through it.

The colour code used on resistors is:

- 0 Black
- 1 Brown
- 2 Red
- 3 Orange
- 4 Yellow
- 5 Green
- 6 Blue
- 7 Purple (Violet if your colour vision is very good)
- 8 Grey
- 9 White

Each resistor has typically, three colour bands to indicate its value. The first two bands are the numbers and the third band is the number of noughts:

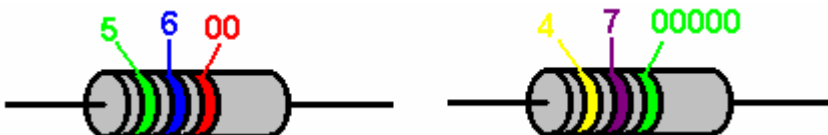

Green: 5
 Blue: 6
 Red: 2 noughts
 Value: 5,600 ohms or 5.6K or 5K6

Yellow: 4
 Purple: 7
 Green: 5 noughts
 Value: 4,700,000 ohms or 4.7M or 4M7

The colour bands are read from left to right and the first band is close to one end of the body of the resistor. There is often a fourth band which indicates the manufacturing tolerance: you can ignore that band.

Examples:

- Red, Red, Red: 2 2 00 ohms or 2K2
- Yellow, Purple, Orange: 4 7 000 ohms or 47K
- Brown, Black, Brown: 1 0 0 ohms or 100R
- Orange, Orange, Orange: 3 3 000 ohms or 33K
- Brown, Green, Red: 1 5 00 ohms or 1K5
- Brown, Green, Black: 1 5 no noughts, or 15 ohms
- Blue, Grey, Orange: 6 8 000 ohms or 68K
- Brown, Green, Green: 1 5 00000 ohms or 1,500,000 ohms or 1M5
- Yellow, Purple, Brown: 4 7 0 ohms

As there are only 12 standard resistor values per decade, there are only 12 sets of the first two colour bands:

- 10:** Brown/Black,
- 12:** Brown/Red,
- 15:** Brown/Green,
- 18:** Brown/Grey
- 22:** Red/Red,
- 27:** Red/Purple
- 33:** Orange/Orange,
- 39:** Orange/White
- 47:** Yellow/Purple
- 56:** Green/Blue
- 68:** Blue/Grey
- 82:** Grey/Red

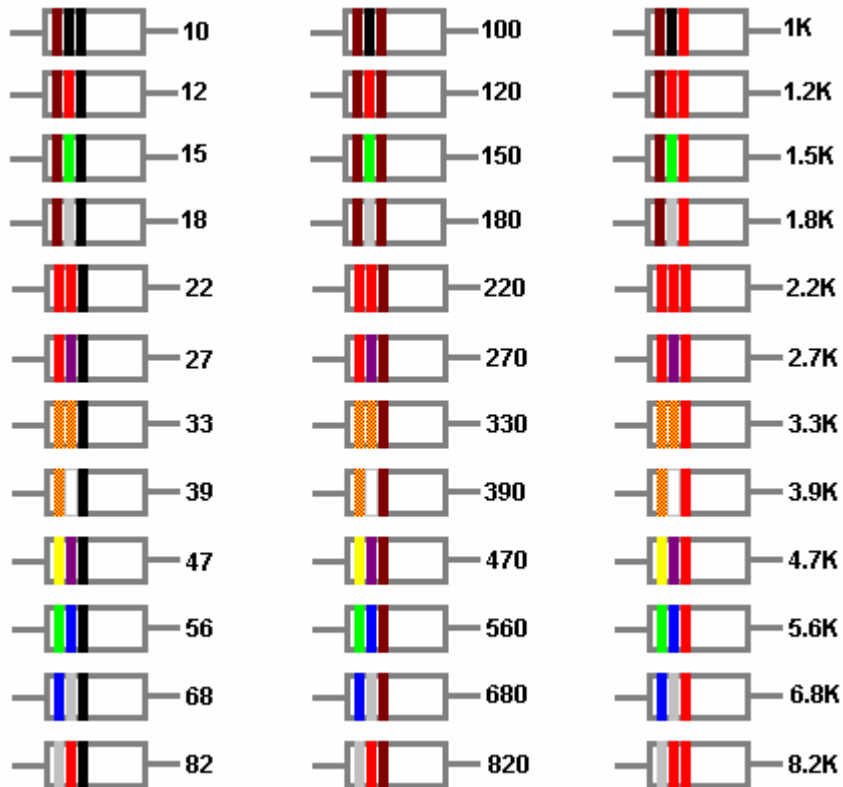

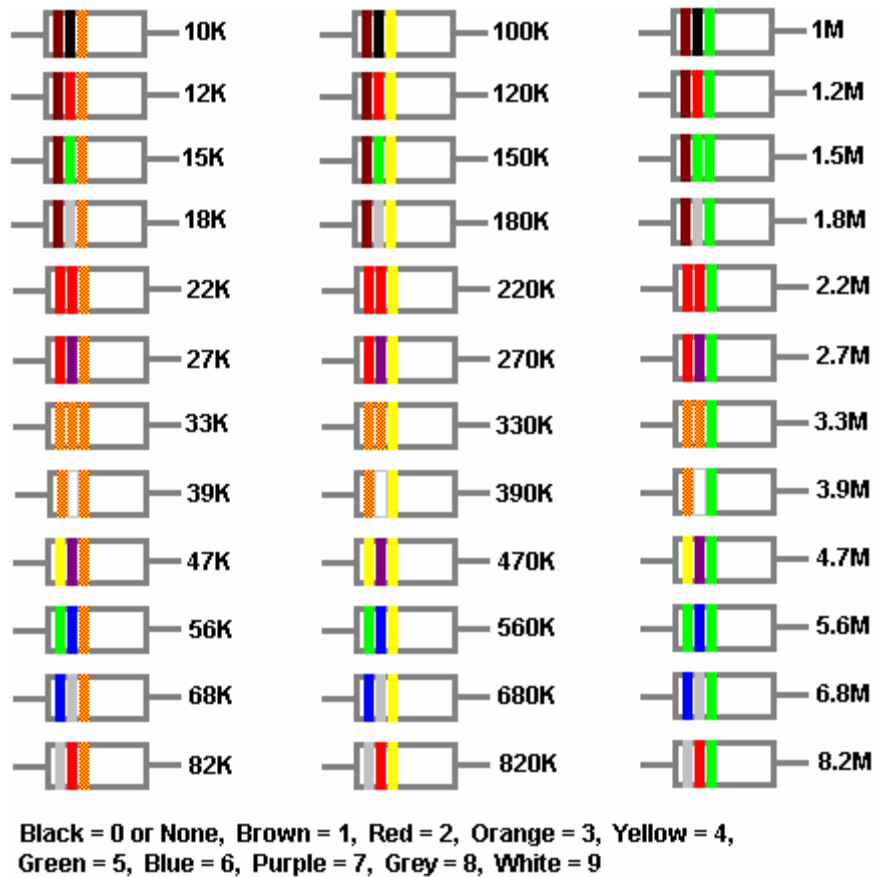

The details above give you all the basic information on resistor colour codes but there are a few additional refinements. There is an extra colour band further down the body of the resistor as shown here:

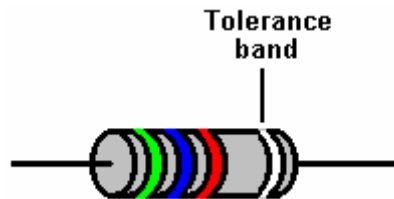

This extra band is used to indicate the manufacturing tolerance of the construction of the resistor. Resistor values are never exact and this rarely has any significant effect on their use in circuits. If some circuit needs very accurate resistor values in it, then buy several resistors of the same nominal value and use an ohm-meter to measure that actual value of each particular resistor and if none are perfect, then use two or more resistors to give the exact value wanted.

The tolerance band has the following codes:

- Silver is $\pm 10\%$ (i.e. a 10K resistor of this type should be between 9K and 11K)
- Gold $\pm 5\%$ (i.e. a 10K resistor of this type should be between 9.5K and 10.5K)
- Red $\pm 2\%$ (i.e. a 10K resistor of this type should be between 9.8K and 10.2K)
- Brown $\pm 1\%$ (i.e. a 10K resistor of this type should be between 9.9K and 10.1K)
- Green $\pm 0.5\%$ (i.e. a 10K resistor of this type should be between 9.95K and 10.05K)
- Blue $\pm 0.25\%$ (i.e. a 10K resistor of this type should be between 9.975K and 10.025K)
- Purple $\pm 0.1\%$ (i.e. a 10K resistor of this type should be between 9.99K and 10.01K)

This type of resistor in the 10% and 5% ranges are the most common as they are the cheapest to buy and so tend to be the most popular. Recently, however, two additions to the coding have been introduced in order to allow for very high specification resistors which the average constructor may never come across. Each of these additions involves one additional colour band. The first additional colour band allows an extra digit in the resistor value, and looks like this:

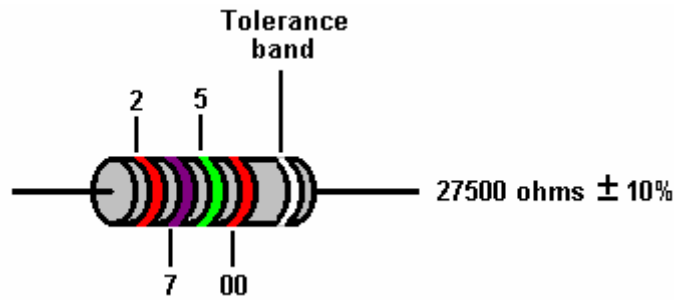

As before, the colour coding is exactly the same, with the fourth colour band specifying the number of zeros after the digits indicated by the colour bands in front of it. So, in the example shown above, the first band being Red indicates a "2". The second colour band being Purple indicates a "7". The third colour band being Green indicates a "5" and the fourth colour band being Red indicates "2 zeros", so putting those together it produces the value of 27,500 ohms, which can also be written as 27.5 K or more briefly as 27K5.

Another example of this is:

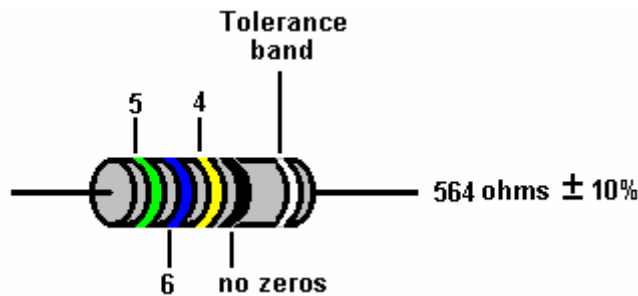

The fourth colour band coding has also been extended to include two other colours:

Gold: meaning "no zeros and divided by 10" so if the band in the example above had been gold, then the value would be 56.4 ohms.

Silver: meaning "no zeros and divided by 100" and if the example band had been silver then the value would have been 5.64 ohms.

So, for example, if the resistor had a fourth colour band which was silver, then the value would be:

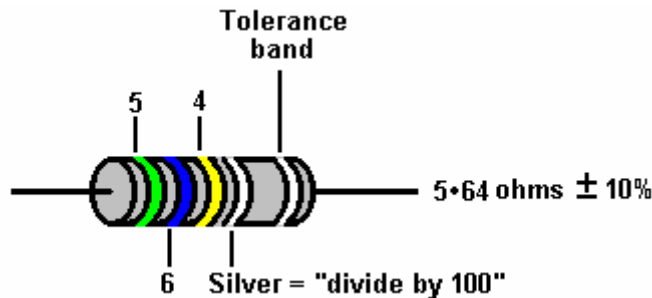

Finally, for very high-quality applications (typically military applications), there can be a sixth colour band positioned outside the tolerance band, and that final colour band states how much the resistance value can be expected to alter with changes in temperature. This is not something which is likely to be of any interest to you, but the codes for that final colour band are:

- Brown: 0.01% of the resistor value for each degree Centigrade change in temperature.
- Red: 0.005% of the resistor value for each degree Centigrade change in temperature.
- Yellow: 0.0025% of the resistor value for each degree Centigrade change in temperature.
- Orange: 0.0015% of the resistor value for each degree Centigrade change in temperature.

To put this in context, the worst of these represents a change of 1% in the resistor value when moving from the temperature of ice to the temperature of boiling water. Is this something which you really care about? I don't.

Leaving the details of identifying individual resistors, we now come to the interesting part: what happens when there are several resistors in a circuit. The important thing is to keep track of the voltages generated within the circuit. These define the currents flowing, the power used and the way in which the circuit will respond to external events. Take this circuit:

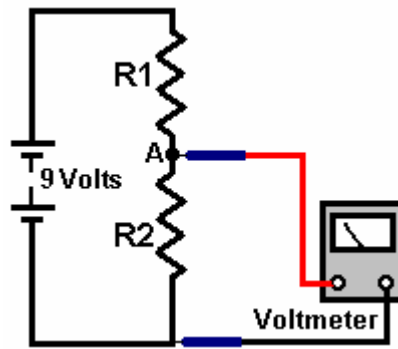

What is the voltage at point 'A'? If you feel like saying "Who cares?" then the answer is "you" if you want to understand how circuits work, because the voltage at point 'A' is vital. For the moment, ignore the effect of the voltmeter used to measure the voltage.

If R1 has the same resistance as R2, then the voltage at 'A' is half the battery voltage, i.e. 4.5 Volts. Half the battery voltage is dropped across R1 and half across R2. It does not matter what the actual resistance of R1 or R2 is, as long as they have exactly the same resistance. The higher the resistance, the less current flows, the longer the battery lasts and the more difficult it is to measure the voltage accurately.

There is no need to do any calculations to determine the voltage at point "A" as it is the ratio of the resistor values which determines the voltage. If you really want to, you can calculate the voltage although it is not necessary. The method for doing this will be shown you shortly. For example, if R1 and R2 each have a value of 50 ohms, then the current flowing through them will be 9 volts / 100 ohms = 0.09 Amps (or 90 milliamps). The voltage drop across R1 will be 50 ohms = Volts / 0.09 amps or Volts = 4.5 volts. Exactly the same calculation shows that the voltage across R2 is exactly 4.5 volts as well. However, the point to be stressed here is that it is the **ratio** of R1 to R2 which controls the voltage at point "A".

If R1 has half as much resistance as R2, then half as much voltage is dropped across it as is dropped across R2, i.e. 3 Volts is dropped across R1, giving point 'A' a voltage of 6 Volts and that is what the voltmeter will show. Again, it does not matter what the actual value of R1 is in ohms, so long as R2 has exactly twice the resistance (shown by a higher number on the resistor).

If R1 has twice as much resistance as R2, then twice as much voltage is dropped across it as is dropped across R2, i.e. 6 Volts is dropped across R1, giving point 'A' a voltage of 3 Volts. Here are some examples with different resistors:

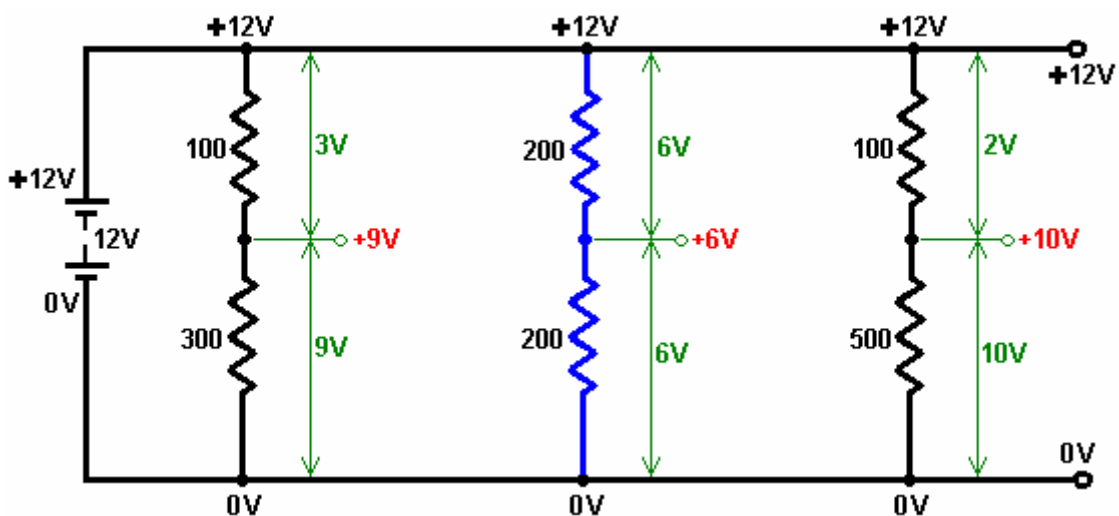

The same division of the supply voltage can be produced by positioning the slider of a variable resistor at different points by rotating the shaft of the device:

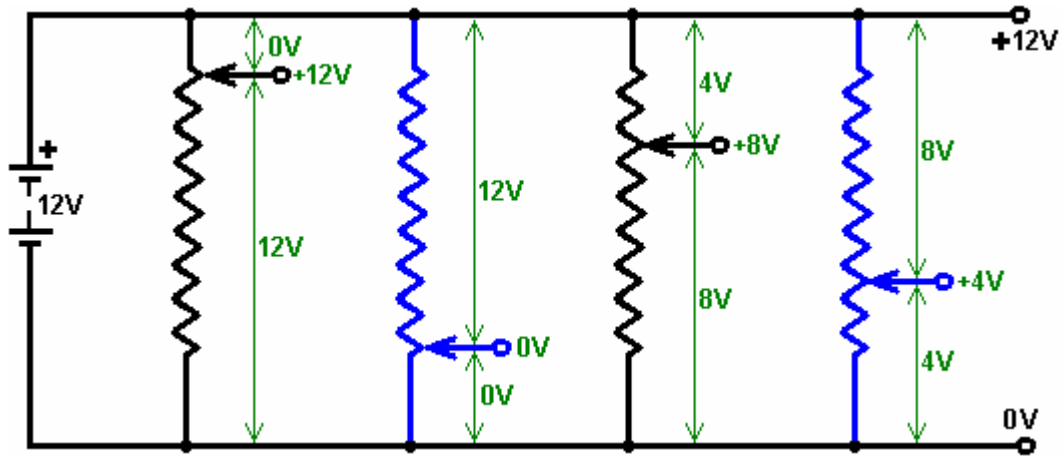

This determination of the voltage levels is the key factor to understanding electronic circuitry. The voltage levels control what currents flow and how every circuit will perform, so it is essential to understand what is happening. Stick with this section until you understand it, and if necessary, ask questions about what you find difficult.

First, please understand that a good battery is an unlimited source of voltage and that voltage does not get “used up” when a resistor or whatever is connected across it:

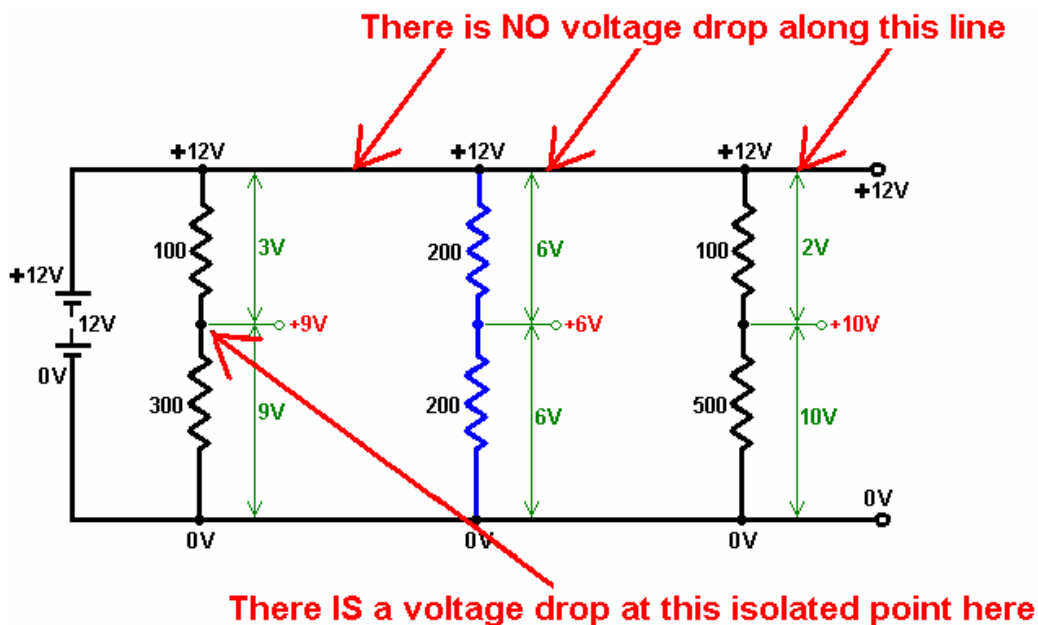

There can be some difficulty in understanding the “0-volt” connection in a circuit. All this means is that it is the return line for current flowing from the battery. Most conventional circuits are connected to both sides of the battery and that allows a current to flow around a closed “circuit” from one terminal of the battery to the other terminal.

It is normal practice to draw a circuit diagram so that the Plus terminal of the battery is at the top and the minus terminal is at the bottom. Many circuit diagrams show the negative line at the bottom connected to the ground or an “earth” connection, which is literally a metal rod driven into the ground to make a good electrical connection to the ground. This is done because the Earth is literally a vast reservoir of negative electricity. However, in reality, most circuits are not connected directly to the Earth in any way. The standard circuit diagram can be visualised as being like a graph of voltage, the higher up the diagram, the higher the voltage.

Anyway, when there is a circuit connected across the battery, the negative or “0V” line just indicates the return path to the battery for the current flow:

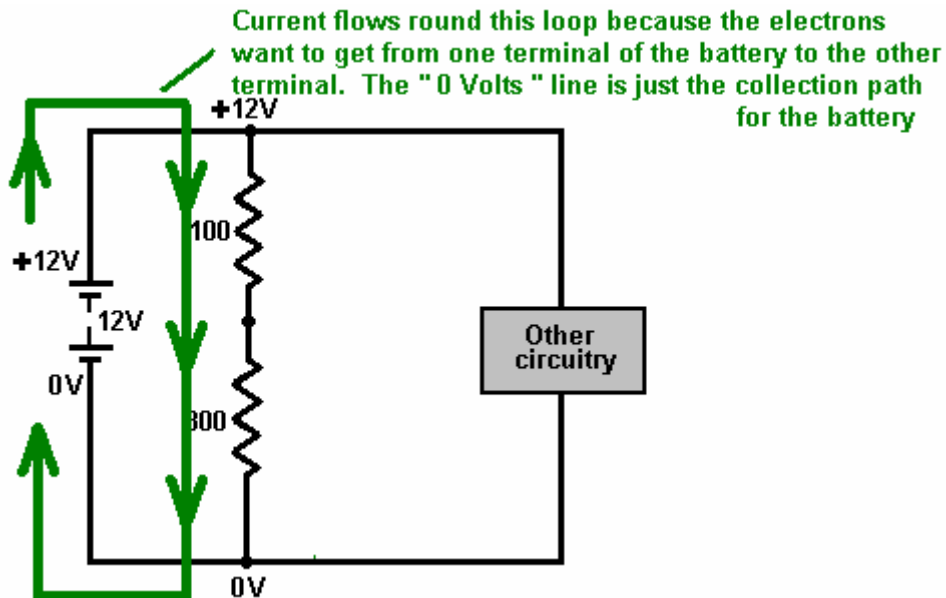

This principle applies immediately to the following circuit:

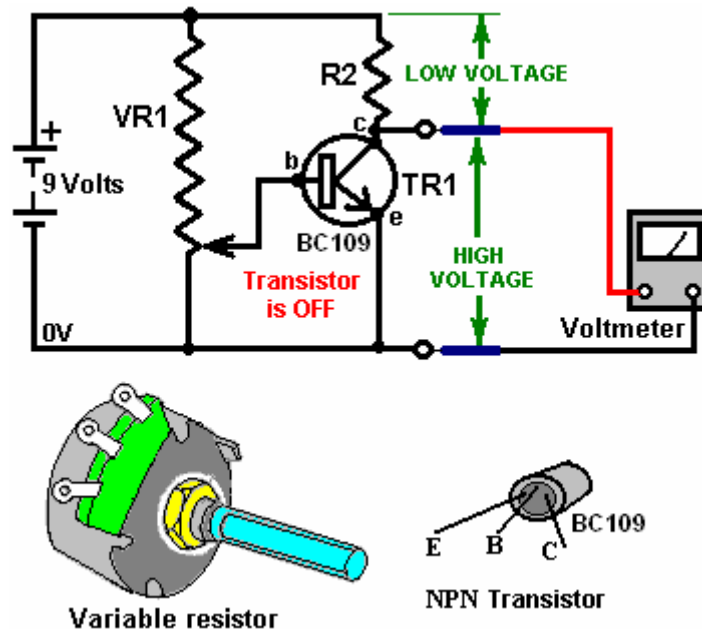

Here we encounter two new components. The first is 'VR1' which is a variable resistor. This device is a resistor which has a slider which can be moved from one end of the resistor to the other. In the circuit above, the variable resistor is connected across the 9 Volt battery so the top of the resistor is at +9 Volts (relative to the battery Minus terminal) and the bottom is at 0 Volts. The voltage on the slider can be adjusted from 0 Volts to 9 Volts by moving it along the resistor by turning the shaft of the component (which normally has a knob attached to it).

The second new device is 'TR1' a transistor. This semiconductor has three connections: a **C**ollector, a **B**ase and an **E**mitter. If the voltage on the base is below 0.7 volts, then the transistor is said to be "OFF" and in that state it has a very high resistance between the collector and the emitter, much higher than the resistance of resistor "R2". The voltage dividing mechanism just discussed means that the voltage at the collector will therefore, be very near to 9 Volts - caused by the **ratio** of the transistor's Collector/Emitter resistance compared to the resistor "R2".

If the voltage on the base of the transistor is raised to 0.7 volts by moving the slider of the variable resistor slowly upwards, then this will feed a small current to the base which then flows out through the emitter, switching the transistor ON causing the resistance between the collector and the emitter to drop instantly to a very low value, much, much lower than the resistance of resistor 'R2'. This means that the voltage at the collector will be very close to 0 Volts. The transistor can therefore be switched on and off just by rotating the shaft of the variable resistor:

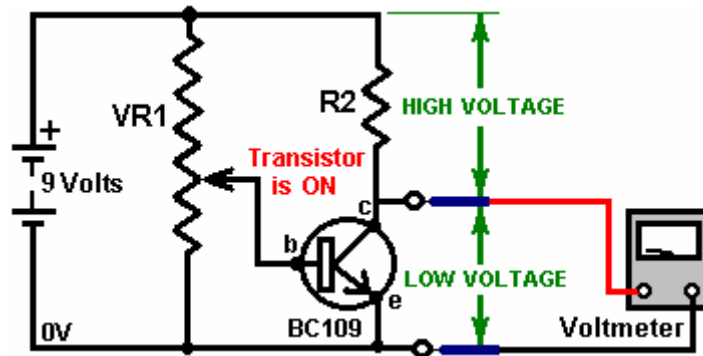

If a bulb is used instead of R2, then it will light when the transistor switches on. If a relay or opto-isolator is used, then a second circuit can be operated:

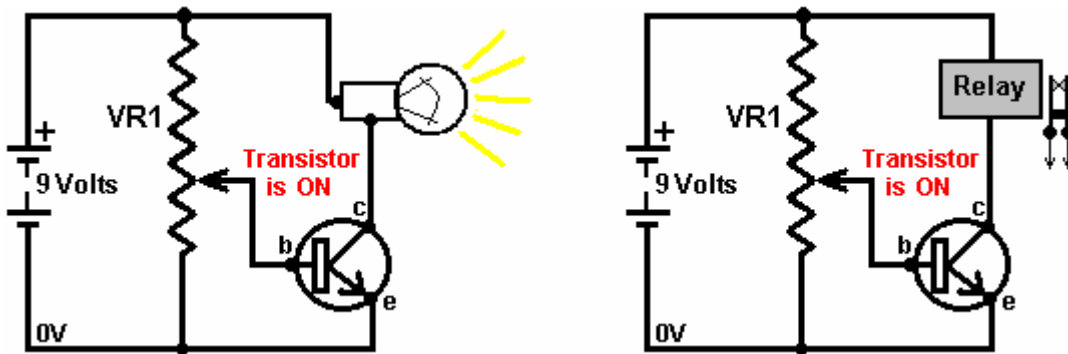

If a buzzer is substituted for R2, then an audible warning will be sounded when the transistor switches on. If a light-dependent resistor is substituted for VR1, then the transistor will switch on when the light level increases or decreases, depending on how the sensor is connected. If a thermistor is used instead of VR1, then the transistor can be switched on by a rise or fall in temperature. The same goes for sound, windspeed, water speed, vibration level, etc. etc. - more of this later.

We need to examine the resistor circuit in more detail:

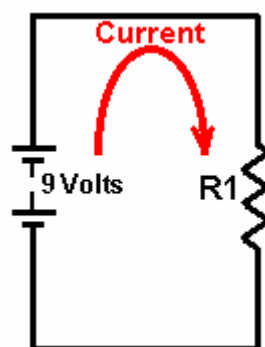

We need to be able to calculate what current is flowing around the circuit. If the circuit contains only resistors, then this can be done using "Ohms Law" which states that "Resistance equals Voltage divided by Current" or, if you prefer:

Ohm's Law (resistive Circuits only).

"Ohms = Volts / Amps" which indicates the units of measurement.

In the circuit above, if the voltage is 9 Volts and the resistor is 100 ohms, then by using Ohm's Law we can calculate the current flowing around the circuit as $100 \text{ Ohms} = 9 \text{ Volts} / \text{Amps}$, or $\text{Amps} = 9 / 100$ which equals 0.09 Amps. To avoid decimal places, the unit of 1 milliamp is used. There are 1000 milliamps in 1 Amp. The

current just calculated would commonly be expressed as 90 milliamps which is written as 90 mA.

In the circuit above, if the voltage is 9 Volts and the resistor is 330 ohms, then by using Ohm's Law we can calculate the current flowing around the circuit as $330 = 9 / \text{Amps}$. Multiplying both sides of the equation by "Amps" gives: $\text{Amps} \times 330 \text{ ohms} = 9 \text{ volts}$. Dividing both sides of the equation by 330 gives: $\text{Amps} = 9 \text{ volts} / 330 \text{ ohms}$ which works out as 0.027 Amps, written as 27 mA.

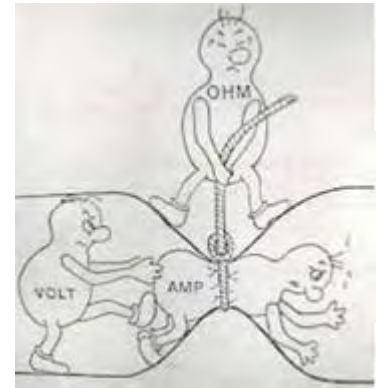

Using Ohm's Law we can calculate what resistor to use to give any required current flow. If the voltage is 12 Volts and the required current is 250 mA then as $\text{Ohms} = \text{Volts} / \text{Amps}$, the resistor needed is given by: $\text{Ohms} = 12 / 0.25 \text{ Amps}$ which equals 48 ohms. The closest standard resistor is 47 ohms (Yellow / Purple / Black).

The final thing to do is to check the wattage of the resistor to make sure that the resistor will not burn out when connected in the proposed circuit. The power calculation is given by: **Watts = Volts x Amps**. In the last example, this gives $\text{Watts} = 12 \times 0.25$, which is 3 Watts. This is much larger than most resistors used in circuitry nowadays.

Taking the earlier example, $\text{Watts} = \text{Volts} \times \text{Amps}$, so $\text{Watts} = 9 \times 0.027$ which gives 0.234 Watts. Again, to avoid decimals, a unit of 1 milliwatt is used, where 1000 milliwatts = 1 Watt. So instead of writing 0.234 Watts, it is common to write it as 234 mW.

This method of working out voltages, resistances and wattages applies to any circuit, no matter how awkward they may appear. For example, take the following circuit containing five resistors:

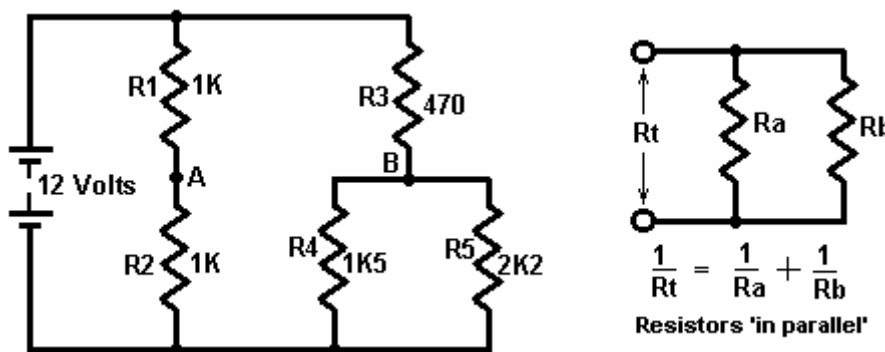

As the current flowing through resistor 'R1' has then to pass through resistor 'R2', they are said to be 'in series' and their resistances are added together when calculating current flows. In the example above, both R1 and R2 are 1K resistors, so together they have a resistance to current flow of 2K (that is, 2,000 ohms).

If two, or more, resistors are connected across each other as shown on the right hand side of the diagram above, they are said to be 'in parallel' and their resistances combine differently. If you want to work out the equation above, for yourself, then choose a voltage across R_t , use Ohm's Law to work out the current through R_a and the current through R_b . Add the currents together (as they are both being drawn from the voltage source) and use Ohm's Law again to work out the value of R_t to confirm that the $1/R_t = 1/R_a + 1/R_b + \dots$ equation is correct. A spreadsheet is included which can do this calculation for you.

In the example above, R_4 is 1K5 (1,500 ohms) and R_5 is 2K2 (2,200 ohms) so their combined resistance is given by $1/R_t = 1/1500 + 1/2200$ or $R_t = 892$ ohms (using a simple calculator). Apply a common-sense check to this result: If they had been two 1500 ohm resistors then the combined value would have been 750 ohms. If they had been two 2200 ohm resistors then the combined value would have been 1100 ohms. Our answer must therefore lie between 750 and 1100 ohms. If you came up with an answer of, say, 1620 ohms, then you know straight off that it is wrong and the arithmetic needs to be done again.

So, how about the voltages at points 'A' and 'B' in the circuit? As R_1 and R_2 are equal in value, they will have equal voltage drops across them for any given current. So the voltage at point 'A' will be half the battery voltage, i.e. 6 Volts.

Now, point 'B'. Resistors R_4 and R_5 act the same as a single resistor of 892 ohms, so we can just imagine two resistors in series: R_3 at 470 ohms and R_4+R_5 at 892 ohms. Common-sense rough check: as R_3 is only about half the resistance of R_4+R_5 , it will have about half as much voltage drop across it as the voltage drop across R_4+R_5 , i.e. about 4 Volts across R_3 and about 8 Volts across R_4+R_5 , so the voltage at point 'B' should work out

at about 8 Volts.

We can use **Ohm's Law** to calculate the current flowing through point 'B':

Ohms = Volts / Amps, (or **Amps = Volts / Ohms** or **Volts = Ohms x Amps**)

$(470 + 892) = 12 / \text{Amps}$, so

$\text{Amps} = 12 / (470 + 892)$

$\text{Amps} = 12 / 1362$ or

$\text{Amps} = 0.00881$ Amps (8.81 milliamps).

Now that we know the current passing through (R4+R5) we can calculate the exact voltage across them:

Resistance = Volts / Amps so

$892 = \text{Volts} / 0.00881$ or

$\text{Volts} = 892 \times 0.00881$

$\text{Volts} = 7.859$ Volts.

As our common-sense estimate was 8 Volts, we can accept 7.86 Volts as being the accurate voltage at point 'B'.

The Potentiometer.

Just before we leave the subject of resistors and move on to more interesting subjects, we come across the term 'potentiometer'. This term is often shortened to 'pot' and many people use it to describe a variable resistor. I only mention this so that you can understand what they are talking about. A variable resistor is not a potentiometer and really should not be called one. You can skip the rest of this part as it is not at all important, but here is what a potentiometer is:

A fancy name for voltage is 'potential', so a circuit powered by a 12 Volt battery can be described as having a 'potential' of zero volts at the negative side of the battery and a 'potential' of plus twelve volts at the positive side of the battery. Ordinary folks like me would just say 'voltage' instead of 'potential'.

When a voltmeter is used to measure the voltage at any point in a circuit, it alters the circuit by drawing a small amount of current from the circuit. The voltmeter usually has a high internal resistance and so the current is very small, **but** even though it is a small current, it **does** alter the circuit. Consequently, the measurement made is not quite correct. Scientists, in years gone by, overcame the problem with a very neat solution - they measured the voltage without taking **any** current from the circuit - neat huh? They also did it with a very simple arrangement:

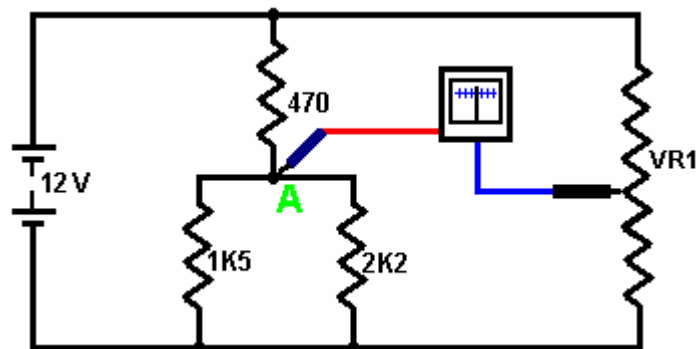

They used a sensitive meter to measure the current. This meter is built so that the needle is in a central position if no current is flowing. With a positive current flowing, the needle deflects to the right. With a negative current flowing, the needle moves to the left. They then connected a variable resistor 'VR1' across the same battery which was powering the circuit. The top end of VR1 is at +12 Volts (they called that 'a potential of +12 Volts') and the bottom end of VR1 is at zero volts or 'a potential of zero volts'.

By moving the slider of VR1, any voltage or 'potential' from zero volts to +12 Volts could be selected. To measure the voltage at point 'A' without drawing any current from the circuit, they would connect the meter as shown and adjust the variable resistor until the meter reading was exactly zero.

Since the meter reading is zero, the current flowing through it is also zero and the current taken from the circuit is zero. As no current is being taken from the circuit, the measurement is not affecting the circuit in any way - very clever. The voltage on the slider of VR1 exactly matches the voltage at point 'A', so with a calibrated scale on the variable resistor, the voltage can be read off.

The slick piece of equipment made up from the battery, the variable resistor and the meter was used to measure the 'potential' (voltage) at any point and so was called a 'potentiometer'. So, please humour me by calling a variable resistor a 'variable resistor' and not a 'potentiometer'. As I said before, this is not at all important, and if you want to, you can call a variable resistor a 'heffalump' so long as you know how it works.

Semiconductors.

This section deals with discrete semiconductors. A later section deals with 'Integrated Circuits' which are large-scale semiconductor devices.

ORP12 Light-dependent resistor. This device has a high resistance in the dark and a low resistance in bright light. It can be placed in a circuit to create a switch which operates with an increase in light level or a decrease in light level:

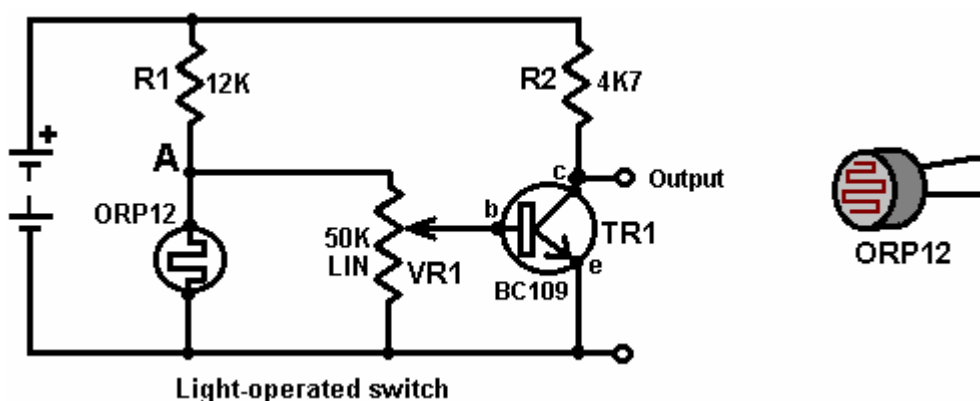

In this version, the voltage at point 'A' controls the circuit. In darkness, the ORP12 has a resistance ten times greater than that of R1 which is 12,000 ohms. Consequently, the voltage at point 'A' will be high. As the light level increases, the resistance of the ORP12 falls, dragging the voltage at point 'A' downwards. As the variable resistor 'VR1' is connected from point 'A' to the ground rail (the -ve of the battery), its slider can be moved to select any voltage between 0 Volts and the voltage of 'A'. A slider point can be chosen to make the transistor switch off in daylight and on at night. To make the circuit trigger when the light level increases, just swap the positions of R1 and the ORP12.

The transistor shown is a BC109 although most transistors will work in this circuit. The BC109 is a cheap, silicon, NPN transistor. It can handle 100mA and 30V and can switch on and off more than a million times per second. It has three connections: the Collector, marked 'c' in the diagram, the Base, marked 'b' in the diagram and the Emitter, marked 'e' in the diagram.

As mentioned before, it has a very high resistance between the collector and the emitter when no current flows into the base. If a small current is fed into the base, the collector/emitter resistance drops to a very low value. The collector current divided by the base current is called the 'gain' of the transistor and is often called 'hfe'. A transistor such as a BC109 or a BC108 has a gain of about 200, though this varies from actual transistor to actual transistor. A gain of 200 means that a current of 200mA passing through the collector requires a current of 1mA through the base to sustain it. Specific information on the characteristics and connections of semiconductors of all kinds can be obtained free from the excellent website www.alldatasheet.co.kr which provides .pdf information files.

The BC109 transistor shown above is an NPN type. This is indicated by the arrow of the symbol pointing outwards. You can also tell by the collector pointing to the positive rail. There are similar silicon transistors constructed as PNP devices. These have the arrow in the transistor symbol pointing inwards and their collectors get connected, directly or indirectly, to the negative rail. This family of transistors are the earliest transistor designs and are called 'bi-polar' transistors.

These silicon transistors are so efficiently constructed that they can be connected directly together to give greatly increased gain. This arrangement is called a 'Darlington pair'. If each transistor has a gain of 200, then the pair give a gain of $200 \times 200 = 40,000$. This has the effect that a very, very small current can be used to power a load.

The following diagram shows a Darlington pair used in a water-level detector. This type of alarm could be very useful if you are asleep on a boat which starts taking on water.

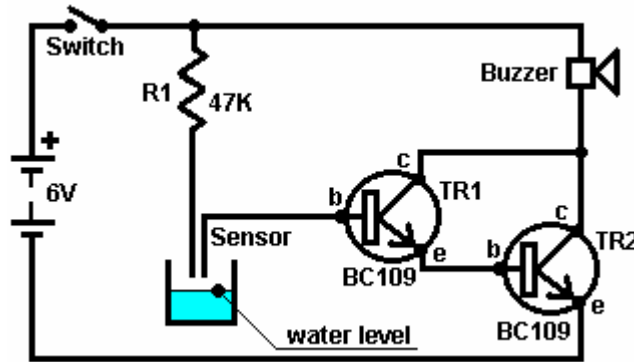

Here, (when the circuit is switched on), transistor TR1 has so little leakage current that TR2 is starved of base current and is hard off, giving it a high resistance across its collector/emitter junction. This starves the buzzer of voltage and keeps it powered off. The sensor is just two probes fixed in place above the acceptable water level. If the water level rises, the probes get connected via the water. Pure water has a high electrical resistance but this circuit will still work with pure water.

The odds are that in a practical situation, the water will not be particularly clean. The resistor R1 is included to limit the base current of TR1 should the sensor probes be short-circuited. Silicon bi-polar transistors have a base/emitter voltage of about 0.7V when fully switched on. The Darlington pair will have about 1.4V between the base of TR1 and the emitter of TR2, so if the sensor probes are short-circuited together, resistor R1 will have $6 - 1.4 = 4.6V$ across it. Ohms Law gives us the current through it as $R = V / A$ or $47,000 = 4.6 / A$ or $A = 4.6 / 47,000$ amps. This works out at 0.098mA which with a transistor gain of 40,000 would allow up to 3.9A through the buzzer. As the buzzer takes only 30mA or so, it limits the current passing through it, and TR2 can be considered to be switched hard on with the whole battery voltage across it.

NPN transistors are more common than PNP types but there is almost no practical difference between them. Here is the previous circuit using PNP transistors:

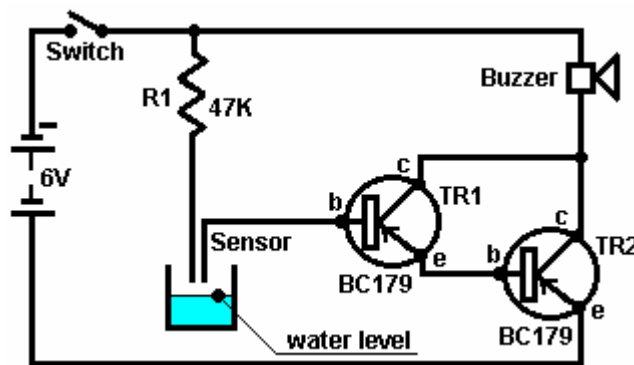

Not a lot of difference. Most of the circuit diagrams shown here use NPN types but not only are these not critical, but there are several ways to design any particular circuit. In general, the semiconductors shown in any circuit are seldom critical. If you can determine the characteristics of any semiconductor shown, any reasonably similar device can generally be substituted, especially if you have a general understanding of how the circuit works. Either of the two previous circuits can operate as a rain detector. A suitable sensor can easily be made from a piece of strip board with alternate strips connected together to form an interlacing grid:

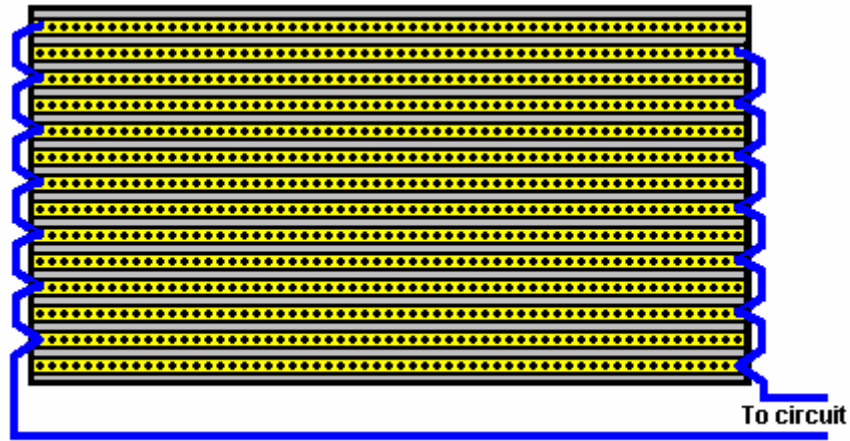

Rain Sensor

Here, if a raindrop bridges between any two adjacent strips, the circuit will trigger and sound a warning.

The transistors in the circuit above are connected with their emitter(s) connected to the ground rail (the lower battery line shown in any circuit is considered to be "ground" unless it is specifically shown elsewhere). This connection method is called 'common emitter'. The following circuit uses the transistor connected in 'emitter follower' mode. This is where the emitter is left to *follow* the base voltage - it is always 0.7V below it unless the base itself is driven below 0.7V:

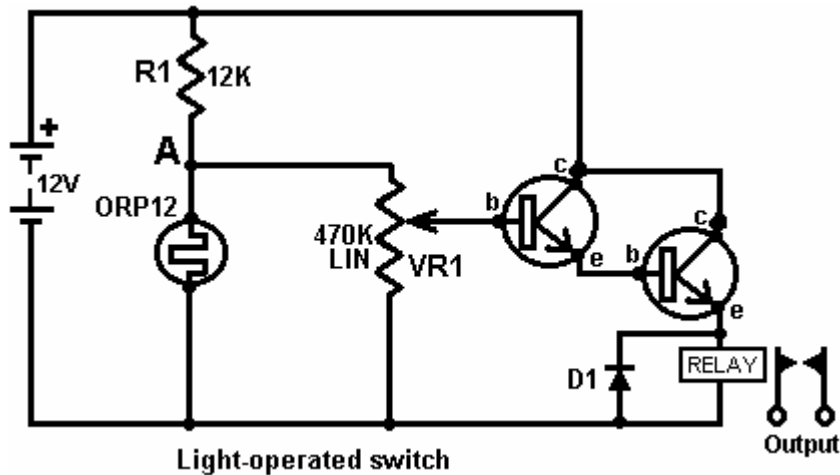

Light-operated switch

This is almost the same as the light-operated circuit shown earlier. In this variation, the transistors are wired so that they work as an 'emitter-follower' which follows the voltage at point 'A' which rises as the light level drops and the resistance of the ORP12 increases. This causes the voltage across the relay to increase until the relay operates and closes its contacts. A relay is a voltage-operated mechanical switch which will be described in more detail later on.

The disadvantage of the above circuit is that as the light level decreases, the current through the relay increases and it may be a significant amount of current for some considerable time. If it was intended to power the unit with a battery then the battery life would be far shorter than it need be. What we would like, is a circuit which switched rapidly from the Off state to the On state even though the triggering input varied only slowly. There are several ways to achieve this, one of them being to modify the circuit to become a 'Schmitt Trigger':

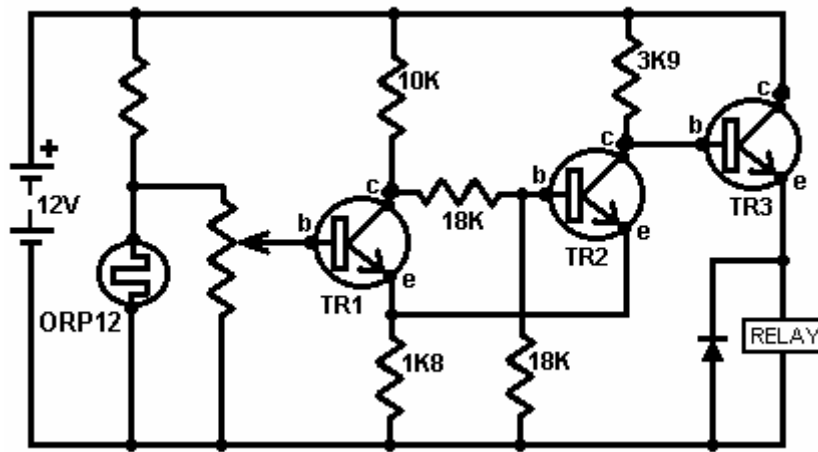

Here, an additional transistor ('TR2') has changed the circuit operation significantly, with transistor TR3 switching fully on and fully off, rapidly. This results in the current through the relay being very low until the circuit triggers.

The circuit operates as follows. When the voltage at the base of TR1 is high enough, TR1 switches on, which causes the resistance between its collector and emitter to be so low that we can treat it as a short circuit (which is a nearly-zero resistance connection). This effectively connects the 10K and 1K8 resistors in series across the battery. The voltage at their connecting point (both the collector and emitter of TR1) will then be about 1.8 Volts. The two 18K resistors are in series across that voltage so the voltage at their junction will be half that; 0.9 Volts.

This puts the Base of TR2 at about 0.9 Volts and its emitter at 1.8 Volts. The base of TR2 is therefore not 0.7 Volts above its emitter, so no base/emitter current will flow in TR2, which means that TR2 is switched hard off. This means that the TR2 collector/emitter resistance will be very high. The voltage at the base of TR3 is controlled by the 1K8 resistor, the TR2 collector/emitter resistance (very high) and the 3K9 resistor. This pushes the base voltage of TR3 up to near the full battery voltage and as it is wired as an emitter-follower, its emitter voltage will be about 0.7 Volts below that. This means that the relay will have most of the battery voltage across it and so will switch hard on.

Some practical points: The current flowing into the base of TR3 comes via the 3K9 resistor. A 3K9 resistor needs 3.9 Volts across it for every 1 mA which flows through it. If the relay needs 150 mA to operate and TR3 has a gain of 300, then TR3 will need a base current of 0.5 mA to provide 150 mA of current through its collector/emitter junction. If 0.5 mA flows through the 3K9 resistor, there will be a voltage drop across it of some 2 Volts. The TR3 base/emitter voltage will be a further 0.7 Volts, so the voltage across the relay will be about $12.0 - 2.0 - 0.7 = 9.3$ Volts, so you need to be sure that the relay will work reliably at 9 Volts.

If you used a Darlington pair of transistors, each with a gain of 300, instead of TR3, then their combined base/emitter voltage drop would be 1.4 Volts, but they would only need a base current of $150 \text{ mA} / (300 \times 300) = 1/600 \text{ mA}$. That current would only drop 0.007 Volts across the 3K9 resistor, so the relay would receive 10.6 Volts.

So, how do you work out the gain of any particular transistor? The main working tool for electronics is a multimeter. This is a digital or analogue meter which can measure a wide range of things: voltage, current, resistance, ... The more expensive the meter, generally, the greater the number of ranges provided. The more expensive meters offer transistor testing. Personally, I prefer the older, passive multimeters. These are looked down on because they draw current from the circuit to which they are attached, but, because they do, they give reliable readings all the time. The more modern battery-operated digital multimeters will happily give incorrect readings as their battery runs down. I wasted two whole days, testing rechargeable batteries which appeared to be giving impossible performances. Eventually, I discovered that it was a failing multimeter battery which was causing false multimeter readings.

Transistor Testers.

For the moment, let us assume that no commercial transistor tester is to hand and we will build our own (or at least, discover how to build our own). The gain of a transistor is defined as the collector/emitter current divided by the base/emitter current. For example, if 1mA is flowing through the collector and 0.01mA is flowing into the base to sustain that collector flow, then the transistor has a gain of 100 times at 1mA. The transistor gain may vary when it is carrying different current loads. For the circuits we have been looking at so far, 1mA is a reasonable current at which to measure the transistor gain. So let's build a circuit to measure the gain:

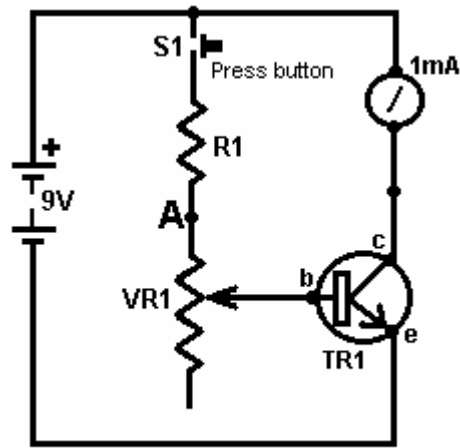

Transistor Tester

With the circuit shown here, the variable resistor is adjusted until a collector current of 1mA is shown on the milliammeter and the gain of the transistor is then read off the scale on the variable resistor knob. The circuit is built into a small box containing the battery and with a socket into which the transistor can be plugged. The question then is, what values should be chosen for the resistor R1 and the variable resistor VR1?

Well, we might choose that the minimum gain to be displayed is 10. This would correspond to where the variable resistor slider is taken all the way up to point 'A' in the circuit diagram, effectively taking the variable resistor out of the circuit. If the transistor gain is 10 and the collector current is 1mA, then the base current will be 0.1mA. This current has to flow through the resistor R1 and it has a voltage of (9.0 - 0.7) Volts across it as the base/emitter voltage is 0.7 Volts when the transistor is on. Ohms Law gives us Ohms = Volts / Amps, which for the resistor R1 means Ohms = 8.3 / 0.0001 or 83,000 ohms, or 83K.

Rule of thumb: 1K provides 1mA if it has 1V across it, so 10K will give 0.1mA if it has 1 Volt across it. With 8.3 Volts across it, it needs to be 8.3 times larger to hold the current down to the required 0.1mA so the resistor should be 83K in size.

As 83K is not a standard size, we need to use two or more standard resistors to give that resistance. Nearest standard size below 83K is 82K, so we can use one 82K resistor and one 1K resistor in series to give the required 83K.

Suppose that we say that we would like to have 500 as the highest gain shown on our tester, then when VR1 is at its maximum value, it and R1 should provide 1/500 of the collector current of 1mA, i.e. 0.002mA or 0.000002 Amps. From Ohms Law again we get VR1 + R1 = 4,150,000 ohms or 4M15. Unfortunately, the largest value variable resistor available is 2M2 so the circuit as it stands, will not be able to cope.

Suppose we were to just use a 2M2 variable resistor for VR1, what transistor gain range could we display? Well Ohms Law ... lets us calculate the base current with 8.3 Volts across (83,000 + 2,200,000) ohms and from that the maximum transistor gain which would be 277.77 (at 1mA). You would buy a 'linear' standard carbon track variable resistor so that the change in resistance is steady as the shaft is rotated. The scale which you would make up would be in even steps and it would run from 10 at the minimum setting, to 278 at the highest setting.

But that is not what we wanted. We wanted to measure up to 500. But they don't make variable resistors big enough, so what can we do? Well, if we wanted, we could lower the battery voltage, which in turn would lower the resistor values. As a 9V battery is very convenient for this kind of circuit, lets not go down that route. We could add extra circuitry to drop the 9V battery voltage down to a lower value. The most simple solution is to add an extra resistor and switch to give two ranges. If we switched in an extra 2M2 resistor above VR1 then the circuit would measure transistor gains from 278 to just over 500 and all we would need to do would be to add a second scale for the VR1 pointer knob to move over. We could, provide extra ranges which overlap and which have more convenient scales to mark. The design is up to you.

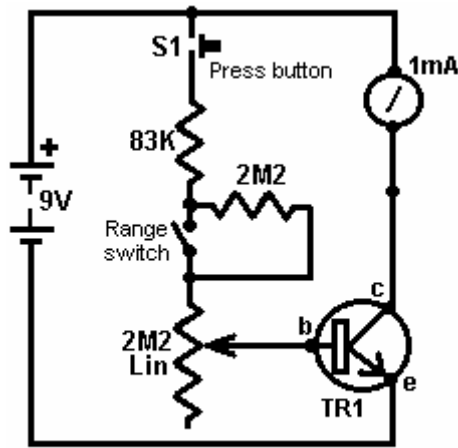

Transistor Tester 2

The design covered above is not the only way to measure the transistor gain. A second way, which accepts that it is not so accurate, picks a set base current and measures the collector current as a guide to the gain. In this simple method, one or more resistor values are chosen to give gain ranges, and the milliammeter used to read the corresponding gain:

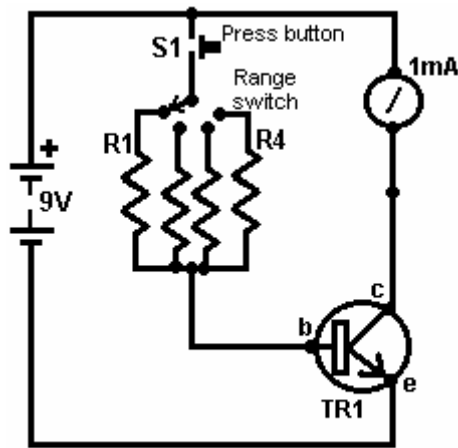

Transistor Tester 3

Here, resistor R1 might be chosen to give a collector current of 1mA (which is a full-scale deflection on the meter) when the transistor gain is 100. Resistor R2 might be picked to give a full-scale deflection for a gain of 200, R3 for a gain of 400, R4 for a gain of 600, and so on. Generally speaking, it is not essential to know the exact gain but any reasonable approximation to it is sufficient. You are normally selecting a transistor where you need a gain of 180, so it is not important if the transistor you pick has a gain of 210 or 215 - you are only avoiding transistors with gains below 180.

How do you work out the values of the resistors R1 to R4? Well, you probably won't expect this, but you use Ohms Law. Voltage drop is 8.3 Volts and the base current is given by the full-scale deflection's 1mA divided by the transistor gain for each range, i.e. 1/100 mA for R1, 1/200 mA for R2,... 1/600 mA for R4,...

The Diode.

One component which has been shown but not described is the diode or 'rectifier'. This is a device which has a very high resistance to current flowing in one direction and a very low resistance to current flowing in the opposite direction. The base/emitter junction of a transistor is effectively a diode and, at a push, can be used as such. A proper diode is cheap to buy and has far greater voltage and current handling capacities than the base/emitter junction of a transistor.

Diodes are mainly made from one of two materials: germanium and silicon. Germanium diodes are used with very small alternating currents such as radio signals coming from an aerial. This is because a germanium diode needs only 0.2 Volts or so to carry a current while silicon needs 0.6 to 0.7 Volts (same as a silicon transistor base/emitter junction). Germanium diodes (and transistors) are very sensitive to temperature change and so are normally restricted to low power circuits. One very neat application for a silicon diode is as an 'un-interruptible power supply' where mains failure is caught instantly:

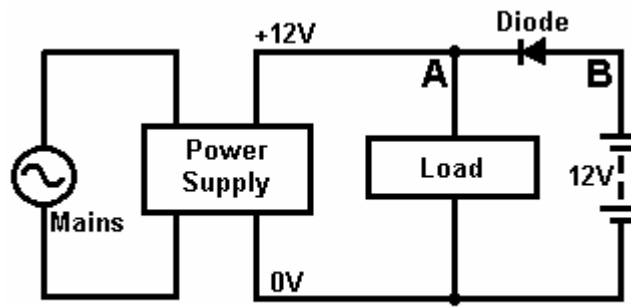

Mains Unit Back-up Circuit

In this circuit, the mains voltage drives the Power Supply Unit which generates 12 Volts at point 'A'. This provides current to the Load. The diode has +12 Volts at 'A' and +12 Volts at point 'B' so there is no voltage drop across it and it will not carry current in either direction. This means that the battery is effectively isolated when the mains is functioning. If the Power Supply Unit output were to rise above its design level of +12 Volts, then the diode would block it from feeding current into the battery.

If the mains fails, the Power Supply Unit ('PSU') output will fall to zero. If the battery and diode were not there, the voltage at point 'A' would fall to zero, which would power-down the Load and possibly cause serious problems. For example, if the load were your computer, a mains failure could cause you to lose important data. With a battery back-up of this type, you would have time to save your data and shut your computer down before the battery ran out.

The circuit operates in a very simple fashion. As soon as the voltage at point 'A' drops to 0.7 Volts below the +12 Volts at point 'B', the diode starts feeding current from the battery to the Load. This happens in less than a millionth of a second, so the Load does not lose current. It would be worth adding a warning light and/or a buzzer to show that the mains has failed.

Diodes are also supplied packaged as a diode bridge, with four diodes enclosed inside. Usually intended for power supply rectification, they are not particularly fast-acting diodes, but are cheap and can carry a good deal of current. A common size is with the diodes rated at 1000 volts and able to carry 35 amps. Although there are many package types, a very common package looks like this:



The alternating signal is connected between two opposite corners and the pulsating DC is taken off from the other two terminals. The symbols shown above are normally marked on the flat face which is not seen in this picture. The package has a hole in the centre so that the metal case can be bolted to a heat-sink in order to keep the device reasonably cool when carrying large currents.

It is possible to connect the bridge in a different way and use it as a higher voltage double diode arrangement as shown here:

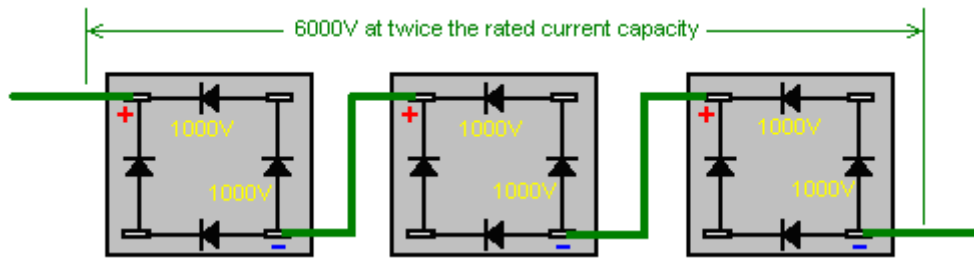

By skipping the alternating current ability and connecting to just the Plus and the Minus terminals, the package provides two pairs of diodes connected in series. This gives twice the voltage handling in both current paths and the rated current handling capacity in both of those two paths which are now connected across each other, which doubles the current handling capacity. The diagram shows how three ordinary, cheap 1000V 35 amp bridges can be connected to give one 70 amp 6000V composite diode.

Diodes are specified by their voltage handling capacity and their current-carrying capacity and the speed at which they can switch on and off. For power supplies where the frequency is very low, any diode will do, but there are circuits where the switching is needed hundreds of thousand times per second and so the diode specification sheets need to be checked to see what frequency can be handled by any particular diode. Those data sheets can be downloaded free from <http://www.alldatasheet.co.kr/>.

One other thing which needs to be checked for some circuits is the voltage needed to get the diode to switch on. Two common materials used when making diodes are silicon and germanium. Germanium types have a low forward voltage of around 0.2 volts typically which silicon has about a 0.6 volt threshold generally. These voltage figures vary enormously as the current through the diode increases. Circuits which use very low voltages need germanium diodes such as the 1N34.



Light-Emitting Diodes.

There is a widely used variation of the diode which is extremely useful, and that is the Light Emitting Diode or 'LED'. This is a diode which emits light when carrying current. They are available in red, green, blue, yellow or white light versions. Some versions can display more than one colour of light if current is fed through their different electrical connections.

LEDs give a low light level at a current of about 8 or 10 mA and a bright light for currents of 20 to 30 mA. If they are being used with a 12 Volt system, then a series resistor of 1K to 330 ohms is necessary. LEDs are robust devices, immune to shock and vibration. They come in various diameters and the larger sizes are very much more visible than the tiny ones.

Thyristors ("SCR"s) and Triacs.

Another version of the diode is the Silicon Controlled Rectifier or 'Thyristor'. This device carries no current until its gate receives an input current. This is just like the operation of a transistor but the SCR once switched on, stays on even though the gate signal is removed. It stays on until the current through the SCR is forced to zero, usually by the voltage across it being removed. SCRs are often used with alternating voltages (described below) and this causes the SCR to switch off if the gate input is removed. SCRs only operate on positive voltages so they miss half of the power available from alternating power supplies. A more advanced version of the SCR is the 'Triac' which operates in the same way as an SCR but handles both positive and negative voltages.

Opto-Isolators.

Another very useful variation on the LED is the Opto-Isolator. This device is a fully enclosed LED and light-sensitive transistor. When the LED is powered up, it switches the transistor on. The big advantage of this device is that the LED can be in a low voltage, low power sensing circuit, while the transistor can be in a completely separate, high voltage, high power circuit. The opto-isolator isolates the two circuits completely from each other. It is a very useful, and very popular, low-cost device.

Alternating Current.

A battery provides a constant voltage. This is called a Direct Current or 'DC' source of power. When a circuit is connected to a battery, the positive rail is always positive and the negative rail is always negative.

If you connect a battery to a circuit through a double-pole changeover switch as shown here:

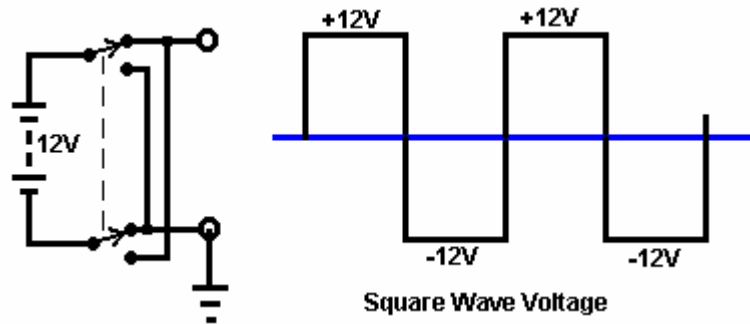

When the changeover switch is operated, the battery is effectively turned over or inverted. This circuit is called an 'inverter' because it repeatedly inverts the supply voltage. If the switch is operated on a regular, rapid basis, the graph of the output voltage is as shown on the right. This is a 'square wave' voltage and is used extensively in electronic equipment. It is called alternating current or 'AC' for short. SCRs and Triacs can be used conveniently with supply voltages of this type. Mains voltage is also AC but is rather different:

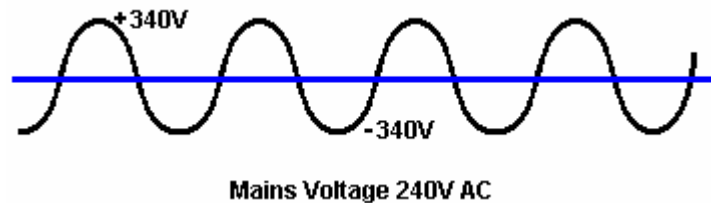

Mains voltage varies continuously in the form of a sine wave. In Britain, the mains voltage is described as '240 Volts AC' and it cycles up and down 50 times per second, i.e. 50 positive peaks and 50 negative peaks in one second. It would be reasonable to assume that each voltage peak would be 240 Volts but this is not the case. Even though the supply is described as 240 Volts, it peaks at the square root of 2 times greater than that, i.e. 339.4 Volts. The actual supply voltage is not particularly accurate, so any device intended for mains use should be rated to 360 Volts. In America, the supply voltage is 110 Volts AC and it cycles 60 times per second, peaking at plus and minus 155 Volts. Later on, you will see how one or more diodes can be used to convert AC to DC in a unit which is sold as a 'mains adapter' intended to allow battery operated equipment be operated from the local mains supply.

Coils ("Inductors") and Solenoids.

If you take a cardboard tube, any size, any length, and wind a length of wire around it, you create a very interesting device. It goes by the name of a 'coil' or an 'inductor' or a 'solenoid'.

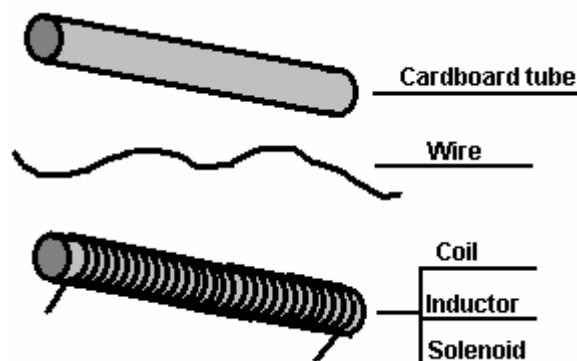

This is a very interesting device with many uses. It forms the heart of a radio receiver, it used to be the main component of telephone exchanges, and most electric motors use several of them. The reason for this is if a current is passed through the wire, the coil acts in exactly the same way as a bar magnet:

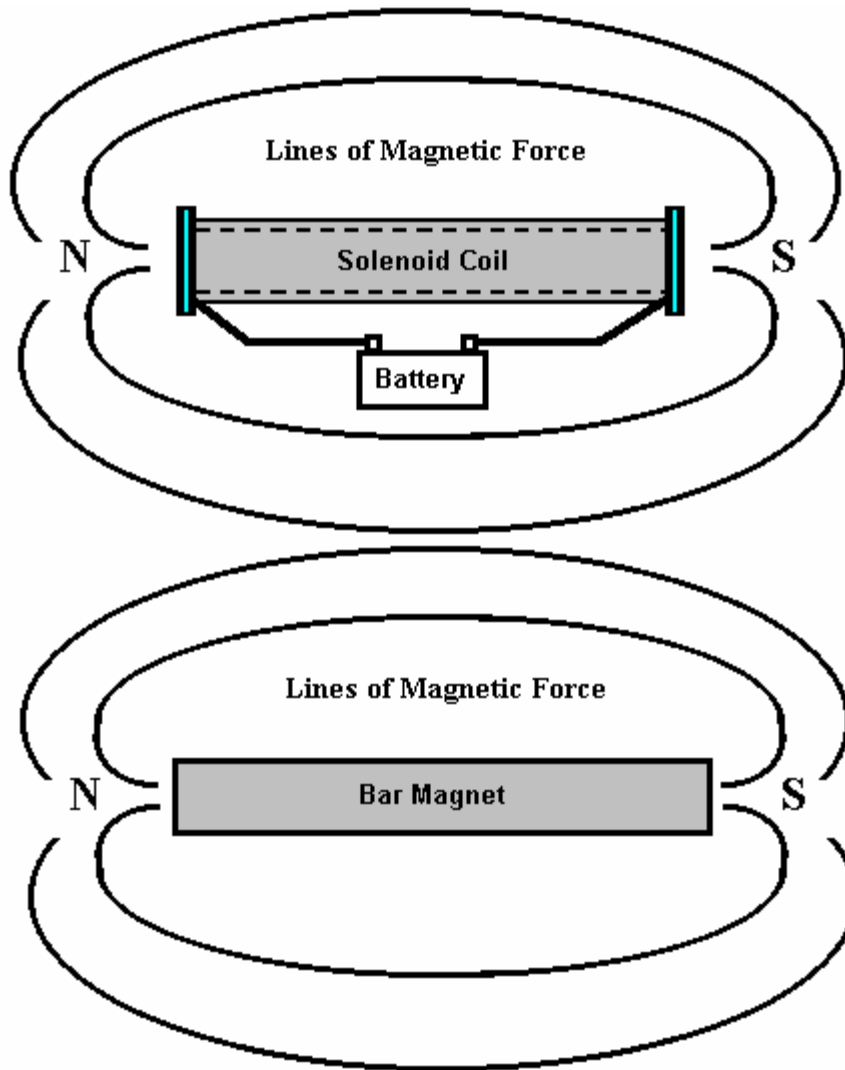

The main difference being that when the current is interrupted, the coil stops acting like a magnet, and that can be very useful indeed. If an iron rod is placed inside the coil and the current switched on, the rod gets pushed to one side. Many doorbells use this mechanism to produce a two-note chime. A 'relay' uses this method to close an electrical switch and many circuits use this to switch heavy loads (a thyristor can also be used for this and it has no moving parts).

A coil of wire has one of the most peculiar features of almost any electronic component. When the current through it is altered in any way, the coil opposes the change. Remember the circuit for a light-operated switch using a relay?:

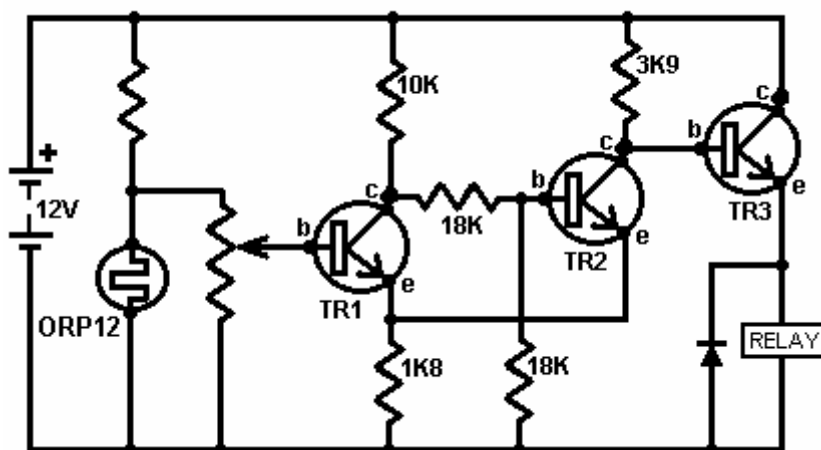

You will notice that the relay (which is mainly a coil of wire), has a diode across it. Neither the relay nor the diode were mentioned in any great detail at that time as they were not that relevant to the circuit being described. The

diode is connected so that no current flows through it from the battery positive to the 'ground' line (the battery negative). On the surface, it looks as if it has no use in this circuit. In fact, it is a very important component which protects transistor TR3 from damage.

The relay coil carries current when transistor TR3 is on. The emitter of transistor TR3 is up at about +10 Volts. When TR3 switches off, it does so rapidly, pushing the relay connection from +10 Volts to 0 Volts. The relay coil reacts in a most peculiar way when this happens, and instead of the current through the relay coil just stopping, the voltage on the end of the coil connected to the emitter of TR3 keeps moving downwards. If there is no diode across the relay, the emitter voltage is forced to briefly overshoot the negative line of the circuit and gets dragged down many volts below the battery negative line. The collector of TR3 is wired to +12 Volts, so if the emitter gets dragged down to, say, -30 Volts, TR3 gets 42 Volts placed across it. If the transistor can only handle, say, 30 Volts, then it will be damaged by the 42 Volt peak.

The way in which coils operate is weird. But, knowing what is going to happen at the moment of switch-off, we deal with it by putting a diode across the coil of the relay. At switch-on, and when the relay is powered, the diode has no effect, displaying a very high resistance to current flow. At switch-off, when the relay voltage starts to plummet below the battery line, the diode effectively gets turned over into its conducting mode. When the voltage reaches 0.7 Volts below the battery negative line, the diode starts conducting and pins the voltage to that level until the voltage spike generated by the relay coil has dissipated. The more the coil tries to drag the voltage down, the harder the diode conducts, stifling the downward plunge. This restricts the voltage across transistor TR3 to 0.7 Volts more than the battery voltage and so protects it.

Solenoid coils can be very useful. Here is a design for a powerful electric motor patented by the American, Ben Teal, in June 1978 (US patent number 4,093,880). This is a very simple design which you can build for yourself if you want. Ben's original motor was built from wood and almost any convenient material can be used. This is the top view:

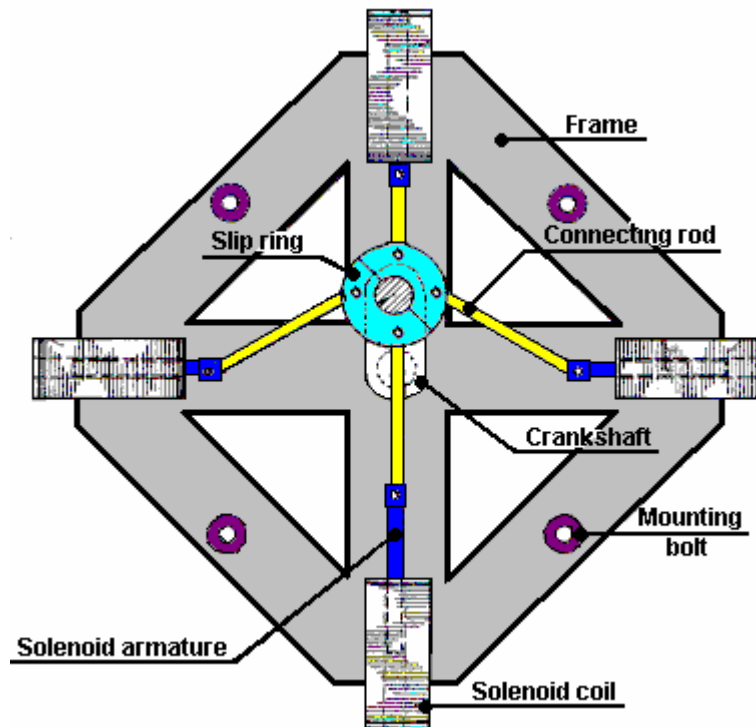

And this is the side view:

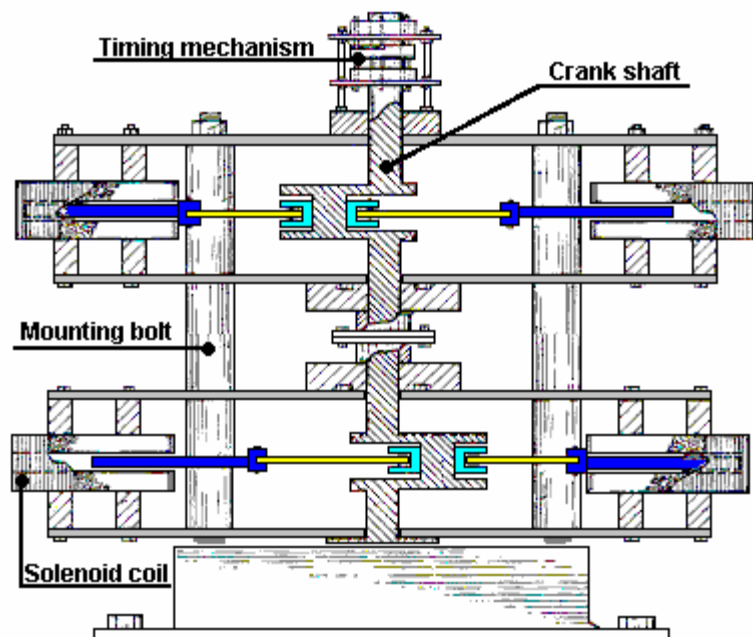

Ben has used eight solenoids to imitate the way that a car engine works. There is a crankshaft and connecting rods, as in any car engine. The connecting rods are connected to a slip-ring on the crankshaft and the solenoids are given a pulse of current at the appropriate moment to pull the crankshaft round. The crankshaft receives four pulls on every revolution. In the arrangement shown here, two solenoids pull at the same moment.

In the side view above, each layer has four solenoids and you can extend the crankshaft to have as many layers of four solenoids as you wish. The engine power increases with every layer added. Two layers should be quite adequate as it is a powerful motor with just two layers.

An interesting point is that as a solenoid pulse is terminated, its pull is briefly changed to a push due to the weird nature of coils. If the timing of the pulses is just right on this motor, that brief push can be used to increase the power of the motor instead of opposing the motor rotation. This feature is also used in the Adams motor described in the 'Free-Energy' section of this document.

The strength of the magnetic field produced by the solenoid is affected by the number of turns in the coil, the current flowing through the coil and the nature of what is inside the coil 'former' (the tube on which the coil is wound). In passing, there are several fancy ways of winding coils which can also have an effect, but here we will only talk about coils where the turns are wound side by side at right angles to the former.

1. Every turn wound on the coil, increases the magnetic field. The thicker the wire used, the greater the current which will flow in the coil for any voltage placed across the coil. Unfortunately, the thicker the wire, the more space each turn takes up, so the choice of wire is somewhat of a compromise.

2. The power supplied to the coil depends on the voltage placed across it. $\text{Watts} = \text{Volts} \times \text{Amps}$ so the greater the Volts, the greater the power supplied. But we also know from Ohm's Law that $\text{Ohms} = \text{Volts} / \text{Amps}$ which can also be written as $\text{Ohms} \times \text{Amps} = \text{Volts}$. The Ohms in this instance is fixed by the wire chosen and the number of turns, so if we double the Voltage then we double the current.

For example: Suppose the coil resistance is 1 ohm, the Voltage 1 Volt and the Current 1 Amp. Then the power in Watts is Volts x Amps or 1×1 which is 1 Watt.

Now, double the voltage to 2 Volts. The coil resistance is still 1 ohm so the Current is now 2 Amps. The power in Watts is Volts x Amps or 2×2 which is 4 Watts. Doubling the voltage has quadrupled the power.

If the voltage is increased to 3 Volts. The coil resistance is still 1 ohm so the Current is now 3 Amps. The power in Watts is Volts x Amps or 3×3 which is 9 Watts. The power is Ohms x Amps squared, or $\text{Watts} = \text{Ohms} \times \text{Amps} \times \text{Amps}$. From this we see that the voltage applied to any coil or solenoid is critical to the power developed by the coil.

3. What the coil is wound on is also of considerable importance. If the coil is wound on a rod of soft iron covered with a layer of paper, then the magnetic effect is increased dramatically. If the rod ends are tapered like a flat

screwdriver or filed down to a sharp point, then the magnetic lines of force cluster together when they leave the iron and the magnetic effect is increased further.

If the soft iron core is solid, some energy is lost by currents flowing round in the iron. These currents can be minimised by using thin slivers of metal (called 'laminations') which are insulated from each other. You see this most often in the construction of transformers, where you have two coils wound on a single core. As it is convenient for mass production, transformers are usually wound as two separate coils which are then placed on a figure-of-eight laminated core.

Transformers.

Transformers are used to alter the voltage of any alternating current power source. If the alteration increases the output voltage, then the transformer is called a 'step-up' transformer. If the output voltage is lower than the input voltage then it is called a 'step-down' transformer. If the voltages are the same, it is called an 'isolation' transformer. A common construction looks like this:

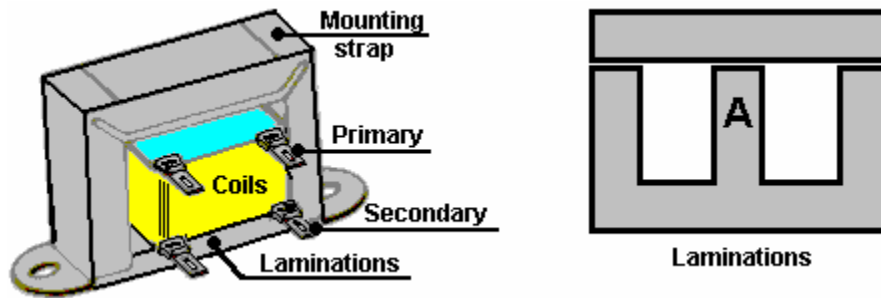

The Coil bobbin sits on the section of the laminations marked 'A' above. The coil is wound on its bobbin former, first one winding and then the second winding. The bobbin is then placed on the central part of the 'E' shaped laminations and then completely surrounded by the laminations when the crossbar is placed on the top. The mounting strap is used to hold the two sets of laminations together and provide mounting lugs for attaching the transformer to a chassis. There are typically, twenty laminations in each set and every lamination is insulated from the adjoining laminations.

If you want to change the voltage of a battery supply, it is possible to build an electronic circuit to generate an alternating voltage and then use a transformer to change that alternating voltage to whatever voltage you want. The most common form of this, is for generating mains voltage from a 12 Volt car battery, so that mains equipment can be run in remote locations, such as boats, caravans, etc. These circuits are called 'inverters' and they are very popular pieces of equipment. The voltage in the secondary coil of any transformer is determined by the ratio of the turns in the primary and secondary windings.

For example; if there is a 10 Volt alternating voltage available and you have a transformer which has 100 turns in the primary coil and 1000 turns in the secondary coil. If you connect the 10 Volts across the primary, there will be 100 Volts generated across the secondary coil.

Instead, if you connect the 10 Volts across the secondary coil, a voltage of 1 Volts will be generated across the primary winding. This is because there is a 10:1 ratio between the two windings. The Law of Conservation of Energy applies to transformers as it does to everything else. The power input to the primary winding will be the same as the power in the secondary winding minus the losses. The losses, in this case, will be a temperature rise of the whole transformer. If the current passed through the transformer is well below its rated capacity, then the losses will be small. The important point is that 10 Volts at 1 Amp into the primary winding will generate 100 Volts in the secondary, but at somewhat less than 0.1 Amps: Power Input is 10 Watts and Power Output is almost 10 Watts. The voltage has been raised to 100 Volts but the potential current draw has been reduced from 1 Amp to 0.1 Amps (100 mA).

In practice, the thickness of the wire used in the windings is very important. If the voltage to be placed across the winding is high, then the wire diameter will be small. Coil windings have fairly low resistances but this is not critical in circuits as coils operate in a peculiar way. Coils have AC 'impedance' in addition to their DC 'resistance'. While Direct Current (from a battery, say) can flow quite easily through a coil with low resistance, Alternating Current may have a hard job getting through the coil due to its high 'impedance'. Sometimes, coils are used to choke off any AC ripple (interference) coming along a DC power cable. When a coil is used for this purpose it is called a 'choke'. Each coil has its own resonant frequency and at that frequency it is very difficult for AC to get through the coil. Crystal set radios work on that principle:

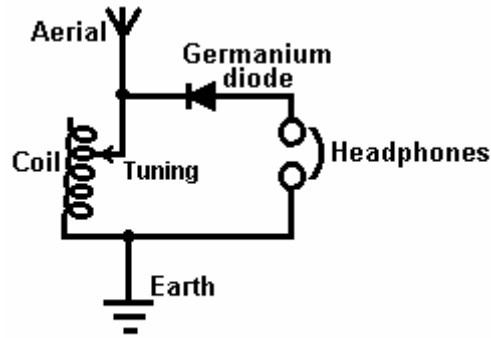

Crystal Set Radio

Here, the aerial picks up every radio station broadcasting in the area. These are all at different frequencies and they all head down the aerial wire, looking for the easiest path to the earth connection. Most of them run through the coil with no problem whatsoever. If the resonant frequency of the coil matches the frequency of one of the radio stations, then that radio signal (and **only** that signal) finds it very hard to get through the coil and looks for an easier path to earth. The next easiest path is through the diode and the headphones, so the signal goes that way. The diode blocks part of the signal which generates the sound of the radio broadcast in the headphones.

This system works very well indeed if there is a good radio signal. A germanium diode is used as the radio signal voltage is very small and a germanium diode operates on 0.2 Volts while a silicon diode needs 0.7 Volts to operate. That difference is significant at these very low voltages. The resonant frequency of the coil depends on the number of turns in the coil. In this design, the coil has a slider which allows the number of turns to be altered and so, different radio stations to be tuned in.

Rectification and Power Supplies.

We now have the question of how do we turn an alternating voltage into a constant 'direct' voltage. The crystal radio set operates by chopping off half of the alternating radio signal. If we were to do this to the output from a mains transformer with an output of say, 12 Volts AC, the result is not very satisfactory:

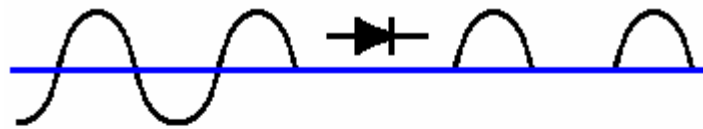

Half-wave rectification

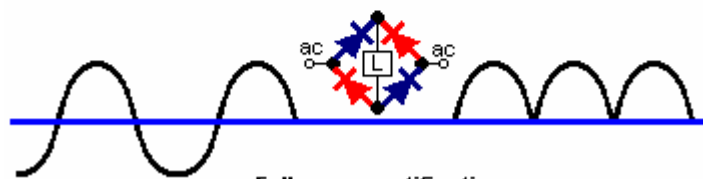

Full-wave rectification

Here, we have the situation shown in the upper diagram. The output consists of isolated pulses at 50 per second. You will notice that there is **no** output power for half of the time. The negative part of the waveform is blocked by the high resistance of the diode while the positive part of the waveform is allowed through by the low resistance of the 'forward-biased' diode. It should be remembered that the diode drops 0.7 Volts when conducting so the output of the half-wave rectified transformer will be 0.7 Volts lower than the transformer's actual output voltage.

If four diodes are used instead of one, they can be arranged as shown in the lower diagram. This arrangement of diodes is called a 'bridge'. Here the positive part of the waveform flows through the upper blue diode, the load 'L' and on through the lower blue diode. The negative part flows through the left hand red diode, the load and then the right hand red diode. This gives a much better output waveform with twice the power available. The output voltage will be 1.4 Volts less than the transformer output voltage as there are two silicon diodes in the supply chain.

The output from even the full-wave rectifier is still unsatisfactory as there is a voltage drop to zero volts 100 times per second. Only a few devices operate well with a power supply like that, an incandescent bulb as used in a car can use this output, but then, it could use the original AC supply without any rectification. We need to improve the output by using a reservoir device to supply current during those moments when the voltage drops to zero. The device we need is a **Capacitor** which used to be called a 'condenser'. The circuit of a mains unit using a capacitor is shown here:

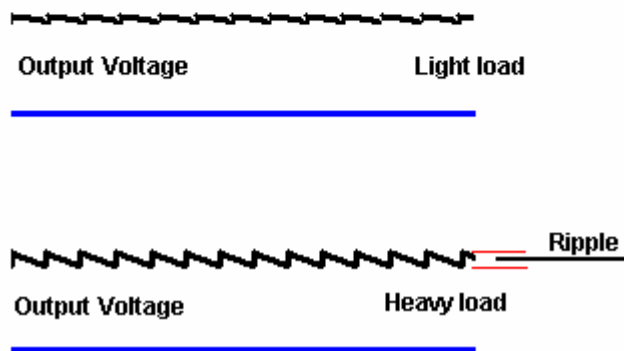
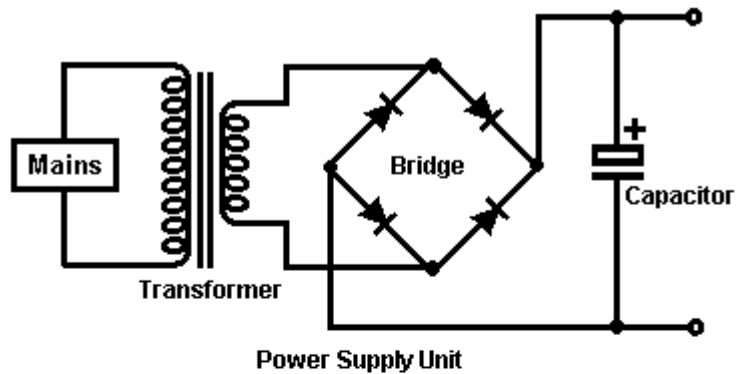

This produces a much better result as the capacitor stores some of the peak energy and gives it out when the voltage drops. If the load on the unit is light with not very much current taken from it, the output voltage is quite good. However, if the current drain is increased, the output voltage gets dragged down 100 times per second. This voltage variation is called 'ripple' and if the unit is supplying an audio system or a radio, the ripple may well be heard as an annoying hum. The larger the capacitor for any given current draw, the smaller the ripple.

To improve the situation, it is normal to insert an electronic control circuit to oppose the ripple:

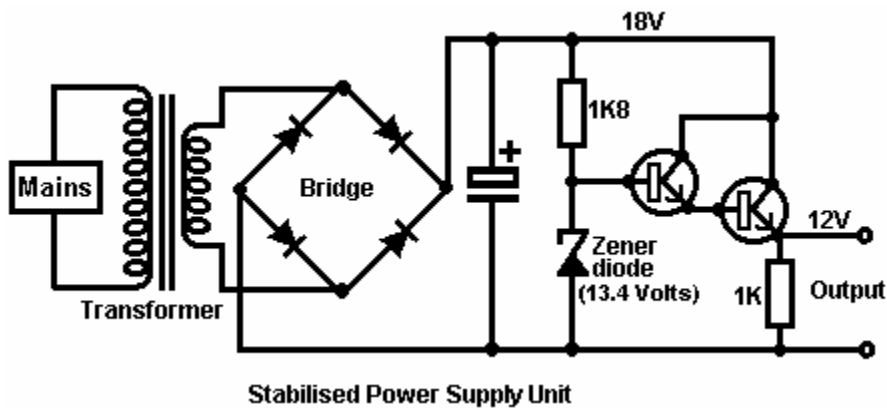

This circuit uses one new component, a new variety of diode called a 'Zener' diode. This device has an almost constant voltage drop across it when its current-blocking direction breaks down. The diode is designed to operate in this state to provide a reference voltage. The circuit merely uses a tiny current from the top of the zener diode to drive the Darlington pair emitter-follower transistors used to provide the output current.

With this circuit, when the output current is increased, the resistance of the transistor pair automatically reduces to provide more current without varying the output voltage. The 1K resistor is included to give the transistors a completed circuit if no external equipment is connected across the output terminals. The zener diode is chosen to give 1.4 Volts more than the required output voltage as the two transistors drop 1.4 Volts when conducting.

You should note that the output transistor is dropping 6 Volts at the full supply current. Watts = Volts x Amps so the power dissipated by the transistor may be quite high. It may well be necessary to mount the transistor on an aluminium plate called a 'heat sink' to keep it from overheating. Some power transistors, such as the 2N3055, do not have the case isolated from the active parts of the transistor. It is good practice to use a mica gasket between the transistor and the heat-sink as it conducts then heat without making an electrical connection to the metal heat-sink.

A capacitor, being an electrical reservoir, can be used as part of a timer circuit. If the current flow into it is restricted by passing it through a resistor. The length of time between starting the flow on an empty capacitor, and the voltage across the capacitor reaching some chosen level, will be constant for a high-quality capacitor.

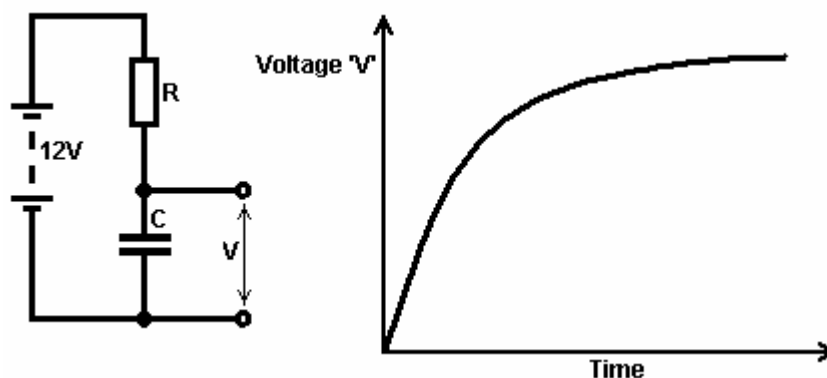

As the voltage increase tails off, it becomes more difficult to measure the difference accurately, so if the capacitor is to be used for generating a time interval, it is normal to use the early part of the graph area where the line is fairly straight and rising fast.

The Voltage Doubler.

It is possible to increase the output voltage of a transformer although this does reduce its ability to supply current at that voltage. The way that this is done is to feed the positive cycles into one storage capacitor and the negative cycles into a second reservoir capacitor. This may sound a little complicated, but in reality, it isn't. A circuit for doing this is shown here:

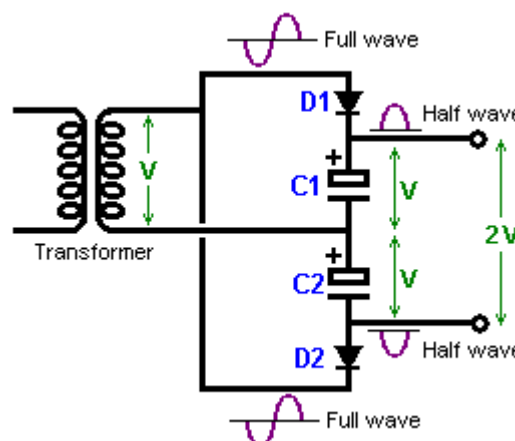

With this circuit, the transformer output is some voltage, say "V" volts of AC current. This output waveform is fed to capacitor "C1" through diode "D1" which lops off the negative part of the cycle. This produces a series of positive half-cycles which charge up capacitor "C1" with a positive voltage of "V".

The other half of the output is fed to capacitor "C2" through diode "D2" which cuts off the positive part of the cycle, causing capacitor "C2" to develop a voltage of -V across it. As the two capacitors are 'in series' and not placed across each other, their voltages add up and produce twice the transformer output voltage.

A word of warning here. The transformer is producing an AC waveform and these are marked with the **average** voltage of the waveform, which is usually a sine wave. The peak voltage of a sinewave is 41% greater than this, so if your transformer has an AC output of 10 volts, then the peaks fed to the capacitors will be about 14.1 volts. If

there is no current draw from the capacitors (that is, with the load switched off), then each capacitor will charge to this 14.1 volts and the overall output voltage will be 28.2 volts and **not** the 20 volts which you might expect. You need to understand that as this is only a half-wave supply, there will be considerable ripple on the output voltage if the current draw is high.

Using one additional smoothing capacitor and paying attention to the voltage ratings of the capacitors, the 28 volts supply circuit might be like this:

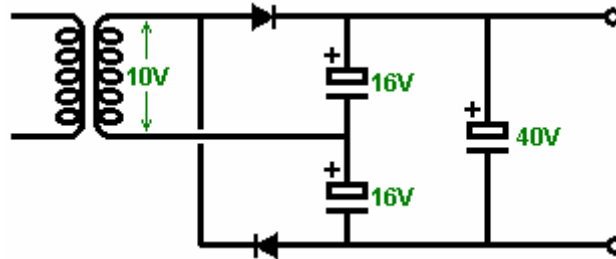

Multivibrators: The Bistable.

The number of electronic circuits which can be built with basic components such as resistors, capacitors, transistors, coils, etc. is limited only by your imagination and needs. Here is a circuit where two transistors operate as a pair:

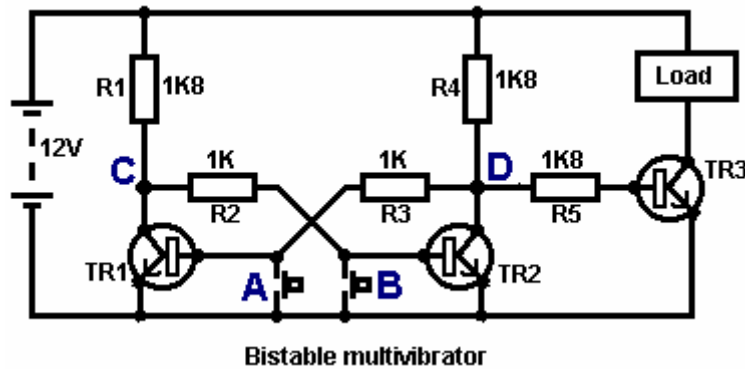

This circuit has two stable states and so it is called a “bi” “stable” or “bistable” circuit. It is important to understand the operation of this simple and useful circuit.

If press-button switch ‘A’ is pressed, it short-circuits the base/emitter junction of transistor TR1. This prevents any current flowing in the base/emitter junction and so switches TR1 hard off. This makes the voltage at point ‘C’ rise as high as it can. This leaves transistor TR2 powered by R1 and R2 which have 11.3 Volts across them and switches TR2 hard on.

This pulls point ‘D’ down to about 0.1 Volts. This happens in less than a millionth of a second. When the press-button switch ‘A’ is released, transistor TR1 does not switch on again because its base current flows through resistor R3 which is connected to point ‘D’ which is far, far below the 0.7 Volts needed to make TR1 start conducting.

The result is that when press-button ‘A’ is pressed, transistor TR2 switches on and stays on even when press-button ‘A’ is released. This switches transistor TR3 off and starves the Load of current. This is the first ‘stable state’.

The same thing happens when press-button ‘B’ is pressed. This forces transistor TR2 into its ‘off’ state, raising point ‘D’ to a high voltage, switching transistor TR3 hard on, powering the Load and holding transistor TR1 hard off. This is the second of the two ‘stable states’.

In effect, this circuit ‘remembers’ which press-button was pressed last, so millions of these circuits are used in computers as Random Access Memory (‘RAM’). The voltage at point ‘C’ is the inverse of the voltage at point ‘D’, so if ‘D’ goes high then ‘C’ goes low and if ‘D’ goes low, then ‘C’ goes high. In passing, the output at ‘D’ is often called ‘Q’ and the output at ‘C’ is called ‘Q-bar’ which is shown as the letter Q with a horizontal line drawn above it. This is shown on the next circuit diagram.

A minor variation of this circuit allows a load to be energised when the circuit is powered up:

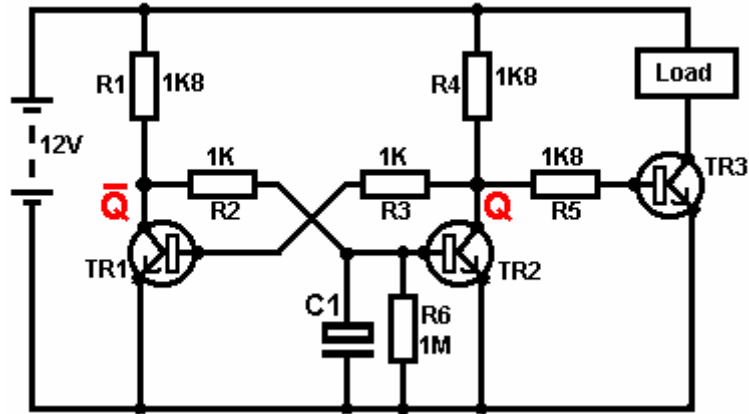

When powered down, the capacitor 'C1' in this circuit is fully discharged through resistor 'R6'. When the 12 Volts supply is connected to the circuit, capacitor C1 does not charge instantly and so holds the base of TR2 down below 0.7 Volts for much longer than it takes for transistor TR1 to switch on (which, in turn, holds TR2 hard off). Mind you, if it is not necessary to have the Load held powered on indefinitely, then an even more simple circuit can do this:

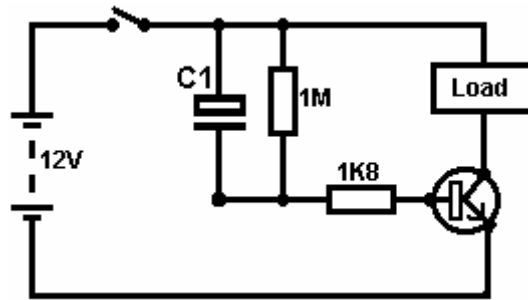

Here, when the switch is closed, both sides of the capacitor C1 are at +12 Volts and this causes the 1K8 resistor to conduct heavily, driving the transistor and powering the load. The capacitor charges rapidly through the transistor and reaches the point at which it can no longer keep the transistor switched on. When the battery is switched off, the 1M resistor discharges the capacitor, ready for the next time the battery is connected.

the Monostable Multivibrator.

The monostable has one stable state and one unstable state. It can be flipped out of its stable state but it will 'flop' back into its stable state. For that reason, it is also known as a 'flip-flop' circuit. It is similar to a bistable circuit, but one of the cross-link resistors has been replaced by a capacitor which can pass current like a resistor, but only for a limited amount of time, after which, the capacitor becomes fully charged and the current flow stops, causing the 'flop' back to the stable state once more.

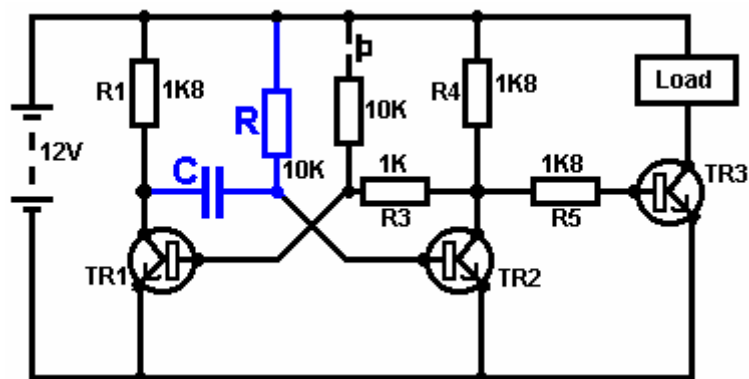

In this circuit, the 'R' resistor and the 'C' capacitor values determine how long the monostable will be in its unstable state. The circuit operates like this:

1. In the stable state, transistor TR1 is off. Its collector voltage is high, pushing the left hand side of capacitor 'C' to near +12 Volts. As the right hand side of capacitor 'C' is connected to the base of TR2 which is at 0.7 Volts, the capacitor gets charged to about 11.3 Volts.
2. The press-button switch is operated briefly. This feeds current through its 10K resistor to the base of transistor TR1, switching it hard on. This drops the collector voltage of TR1 to near 0 Volts, taking the left hand side of the capacitor with it.
3. As the voltage across a capacitor can't change instantly, the right hand side of the capacitor drives the base of transistor TR2 down below 0.7 Volts, causing TR2 to switch off.
4. The circuit can't hold TR2 in its 'off' state for ever. The resistor 'R' feeds current into the capacitor, forcing the voltage at the base of TR2 steadily upwards until the voltage reaches 0.7 Volts and transistor TR2 switches on again, forcing TR1 off again (provided that the press-button switch has been released). This is the stable state again. If the press-button switch is held on, then both transistors will be on and the output voltage will still be low. Another output pulse will not be generated until the press-button is let up and pressed again.

This circuit could be used to switch a microwave oven on for any chosen number of seconds, create a delay on your home-built burglar alarm, to give you time to switch it off after walking through your front door, operate a solenoid valve to feed a pre-determined quantity of beverage into a bottle on a production line, or whatever...

The Astable Multivibrator.

The astable circuit is the monostable with a second capacitor added so that neither state is stable. This results in the circuit flopping backwards and forwards continuously:

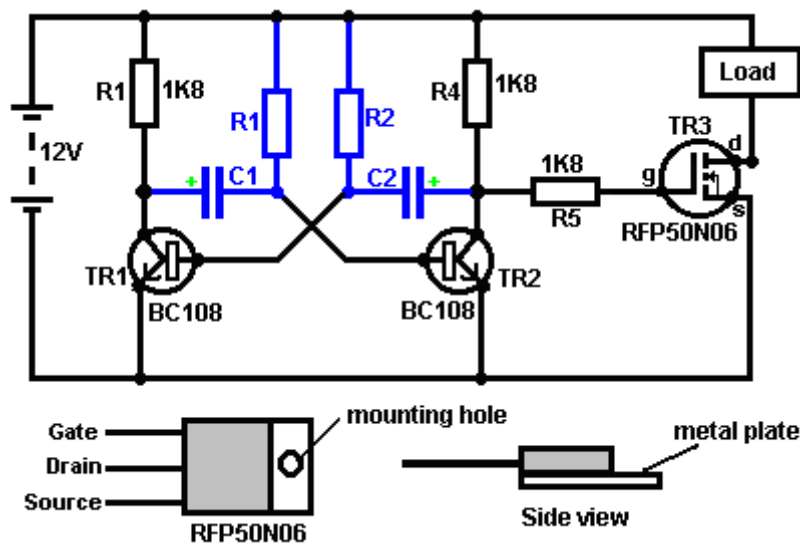

The rate of switching is controlled by the R1/C1 and R2/C2 combinations. The load's ON time to its OFF time is called the 'mark-space' ratio, where the ON period is the 'mark' and the OFF period is the 'space'. If you choose to use electrolytic capacitors which have their own polarity, then the +ve end of each capacitor is connected to the transistor collector.

While it is good to understand how these multivibrator circuits operate and can be built, nowadays there are pre-built circuits encased in a single package which you are much more likely to choose to use. These are called Integrated Circuits or 'ICs' for short. We will be discussing these shortly. Before we do, notice that in the circuit above, transistor TR3 has been changed to a new variety called a **Field Effect Transistor** ('FET'). This type of transistor is newer than the 'bipolar' transistors shown in the earlier circuits. FETs come in two varieties: 'n-channel' which are like NPN transistors and 'p-channel' which are like PNP transistors.

FETs are more difficult to make but have now reached a level of cost and reliability which makes them very useful indeed. They require almost no base current (called 'gate' current with this type of transistor) which means that they have almost no effect on any circuit to which they are attached. Also, many of them can handle large currents and boast major power handling capabilities. Because of this, it is usual to see them packaged with a metal plate mounting, ready to be bolted to an aluminium heat-sink plate to help dissipate the heat generated by the large amount of power flowing through them. The 'RFP50N06' shown above can handle up to 50 Volts and carry up to 60 Amps, which is serious power handling.

Inverters and Truth Tables.

Consider the following circuit:

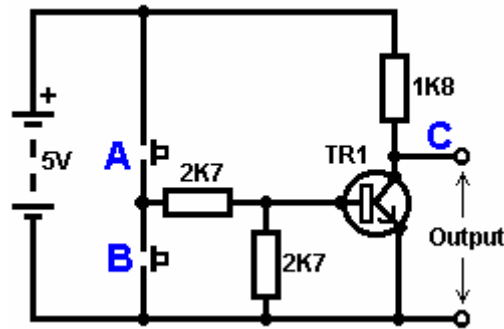

If neither of the press-button switches are operated, the transistor has no base/emitter current flow and so it is off. This places the collector voltage at 'C' near the positive rail (+5 Volts).

If press-button switch 'A' is operated, the base voltage tries to rise to half of the battery voltage but doesn't make it because the transistor base pins it down to 0.7 Volts. This feeds base current to the transistor, switching it hard on and causing the output at 'C' to drop to nearly 0 Volts.

If press-button switch 'B' is operated (don't do this when switch 'A' is closed or you will get a very high 'short-circuit' current flowing directly through the two switches) it has no effect on the output voltage which will stay high.

If we re-draw the circuit like this:

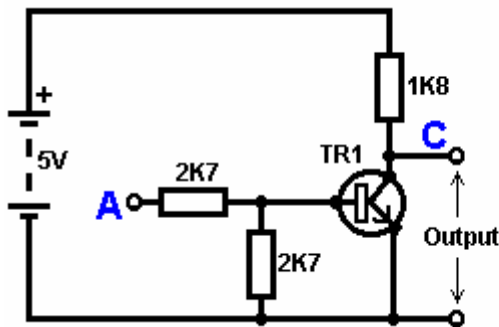

TRUTH TABLE	
Input A	Output C
0	1
1	0

Key:

0 = Less than 0.5 Volts

1 = More than 3.5 Volts

We can see that if the voltage at the input 'A' is taken high, then the output voltage at 'C' will be low. If the voltage at the input 'A' is taken low, then the output voltage at 'C' will be high. A circuit which does this is called an 'Inverter' because it 'inverts' (or 'turns upside down') the input voltage.

We can summarise this operation in a table. Personally, I would call the table an 'Input/Output' table, but for no obvious reason, the standard name is a 'Truth' table. The purpose of this table is to list all of the possible inputs and show the corresponding output for each input.

Another standard, is to substitute '1' for 'High Voltage' and '0' for 'Low Voltage'. You will notice that many items of electrical and electronic equipment have these symbols on the ON / OFF switch. In computer circuitry (hah! you didn't notice that we had moved to computer circuits, did you?), the '0' represents any voltage below 0.5 Volts and the '1' represents any voltage above 3.5 Volts. Many, if not most, computers operate their logic circuits on 5 Volts. This Inverter circuit is a 'logic' circuit.

A criticism of the above circuit is that its input resistance or 'impedance' is not particularly high, and its output impedance is not particularly low. We would like our logic circuits to be able to operate the inputs of eight other logic circuits. The jargon for this is that our circuit should have a 'fan-out' of eight.

Let's go for a simple modification which will improve the situation:

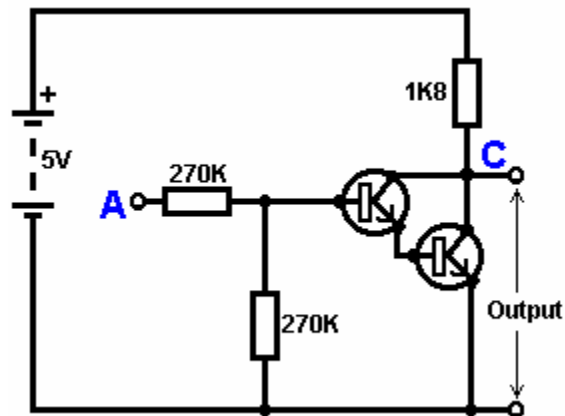

Here, The input impedance has been increased by a factor of 100 by using a Darlington pair of transistors which need far less base current, and so can have a much higher input resistor.

Unfortunately, the output impedance is still rather high when the transistors are in their OFF state as any current taken from the positive line has to flow through the 1K8 (1800 ohm) resistor. But we need this resistor for when the transistors are in their ON state. We really need to change the 1K8 resistor for some device which has a high resistance at some times and a low resistance at other times. You probably have not heard of these devices, but they are called 'transistors'.

There are several ways to do this. We might choose to use PNP transistors (we normally use NPN types) and connect these in place of the 1K8 resistor. Perhaps we might use a circuit like this:

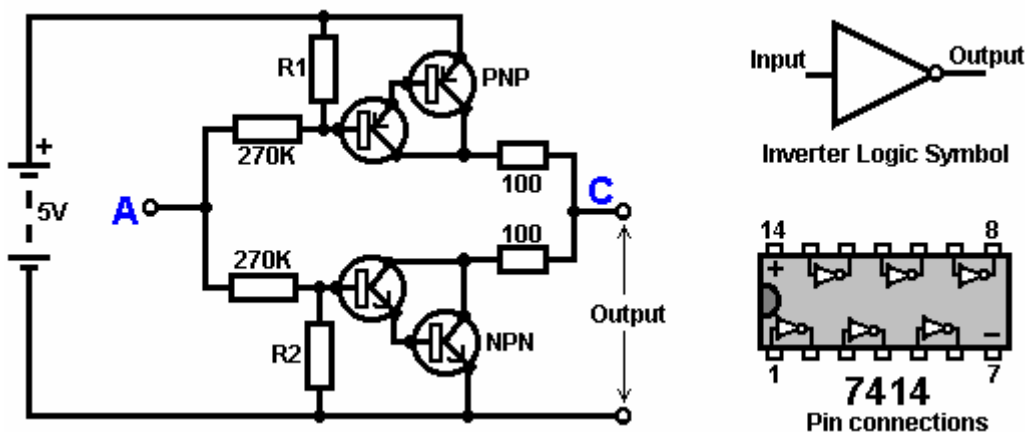

This circuit is starting to look complicated and I don't like complicated circuits. It is not as bad as it looks. The NPN transistors at the bottom are almost the same as the previous circuit. The only difference is that the collector load is now two 100 ohm resistors plus the resistance of the two transistors. If the PNP transistors are OFF when the NPN transistors are ON, then the circuit loading on the NPN transistors will be negligible and the whole of the NPN transistors output will be available for driving external circuits through the lower 100 ohm resistor (a large 'fan-out' for the '0' logic state). To make sure that the PNP transistors are hard off before the NPN transistors start to switch on, the resistor 'R1' needs to be selected carefully.

The PNP transistors are an exact mirror image of the NPN side, so resistor R2 needs to be selected carefully to ensure that the NPN transistors are switched hard OFF before the PNP transistors start to switch ON.

You need not concern yourself unduly with that circuit, because you will almost certainly use an Integrated Circuit rather than building your own circuit from 'discrete' components. An Integrated Circuit containing six complete inverters is the 7414 which is shown above. This comes in a small black case with two rows of 7 pins which make it look a bit like a caterpillar. Because there are two row of pins, the packaging is called "Dual In-Line" or "DIL" for short.

Now, consider the following circuit:

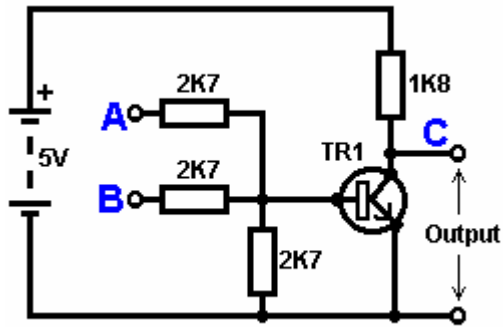

TRUTH TABLE		
Input A	Input B	Output C
0	0	1
0	1	0
1	0	0
1	1	0

0 = Low voltage 1 = High Voltage

This circuit operates the same way as the Inverter circuit, except that it has two inputs ('A' and 'B'). The output voltage at 'C' will be low if either, 'A' OR 'B' or both, of the inputs is high. The only time that the output is high, is when both Input 'A' and Input 'B' are low. Consequently, the circuit is called an "OR" gate. Strictly speaking, because the output voltage goes Down when the input voltage goes Up, it is called a "Not OR" gate, which gets shortened to a "NOR" gate. In this context, the word "not" means "inverted". If you fed the output 'C' into an inverter circuit, the resulting circuit would be a genuine "OR" gate. The digital circuit symbols for an AND gate, a NAND gate, an OR gate and a NOR gate are:

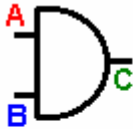

AND Gate

A	0	1	0	1
B	0	0	1	1
C	0	0	0	1

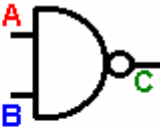

NAND Gate

A	0	1	0	1
B	0	0	1	1
C	1	1	1	0



OR Gate

A	0	1	0	1
B	0	0	1	1
C	0	1	1	1



NOR Gate

A	0	1	0	1
B	0	0	1	1
C	1	0	0	0

Gating.

These common chips are usually supplied with 2, 4 or 8 inputs. So, why is it called a "Gate" - isn't it just a double inverter? Well, yes, it **is** a double inverter, but a double inverter acts as a gate which can pass or block an electronic signal. Consider this circuit:

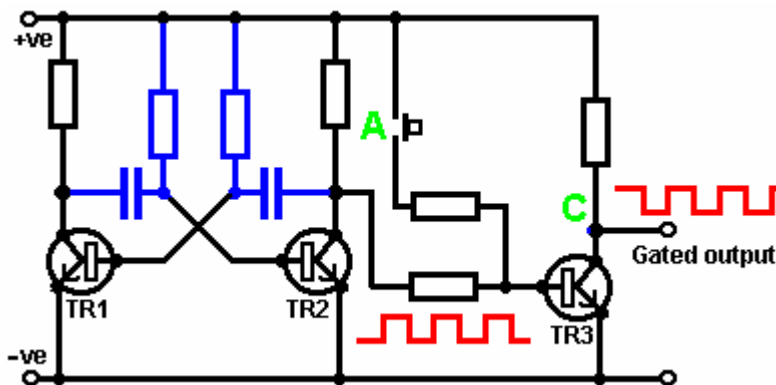

Here, transistors 'TR1' and 'TR2' are connected to form an astable (multivibrator). The astable runs freely, producing the square wave voltage pattern shown in red. Transistor 'TR3' passes this voltage signal on. TR3 inverts the square wave, but this has no practical effect, the output being the same frequency square wave as the signal taken from the collector of TR2.

If the press-button switch at point 'A' is operated, a current is fed to the base of TR3 which holds it hard on. The voltage at point 'C' drops to zero and stays there. The square wave signal coming from the collector of TR2 is blocked and does not reach the output point 'C'. It is as if a physical 'gate' has been closed, blocking the signal from reaching point 'C'. As long as the voltage at point 'A' is low, the gate is open. If the voltage at point 'A' goes high, the gate is closed and the output is blocked.

There is no need for a manual switch at point 'A'. Any electronic switching circuit will do:

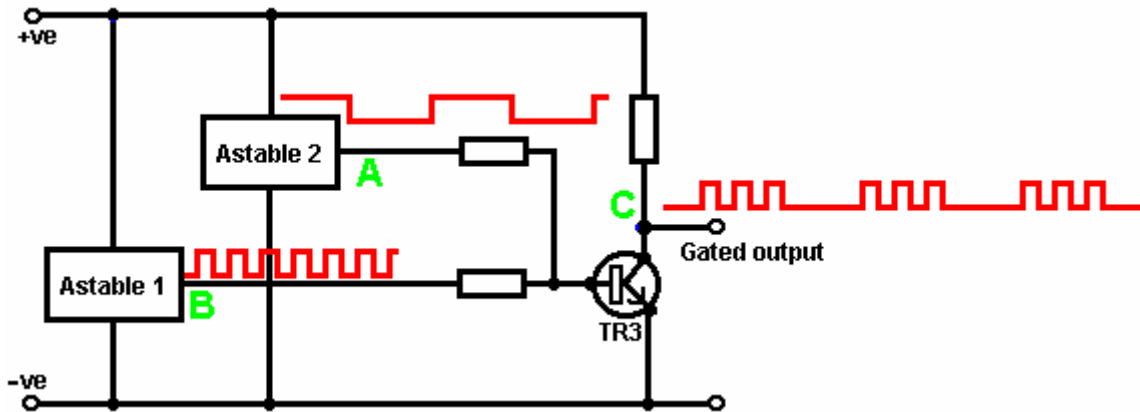

Here, a slow-running astable is substituted for the manual switch. When the output voltage of 'Astable 2' goes high, it switches the gate transistor 'TR3', holding it hard on and blocking the square-wave signal from 'Astable 1'. When the output voltage of 'Astable 2' goes low, it frees transistor 'TR3' and it then passes the 'Astable 1' signal through again. The resulting gated waveform is shown in red at point 'C' and it is bursts of signal, controlled by the running rate of 'Astable 2'. This is the sort of waveform which Stan Meyer found very effective in splitting water into Hydrogen and Oxygen (see Chapter 10).

This circuit could also be drawn as:

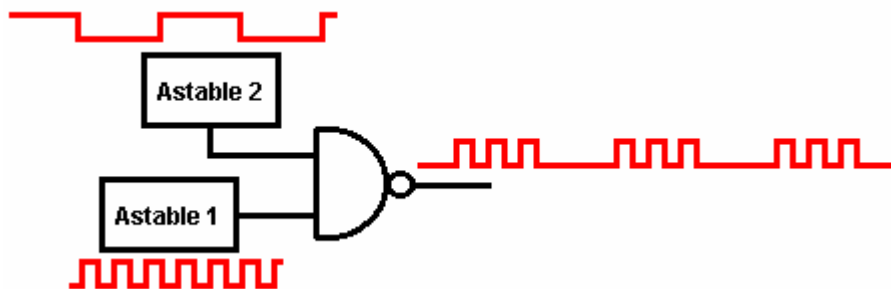

The small circle on the output side of logic devices is to show that they are inverting circuits, in other words, when the input goes up, the output goes down. The two logic devices we have encountered so far have had this circle: the Inverter and the NAND gate.

If you wish, you can use a NAND gate chip which has the circuitry also built as a Schmitt trigger, which as you will recall, has a fast-switching output even with a slowly moving input. With a chip like that, you can get three different functions from the one device:

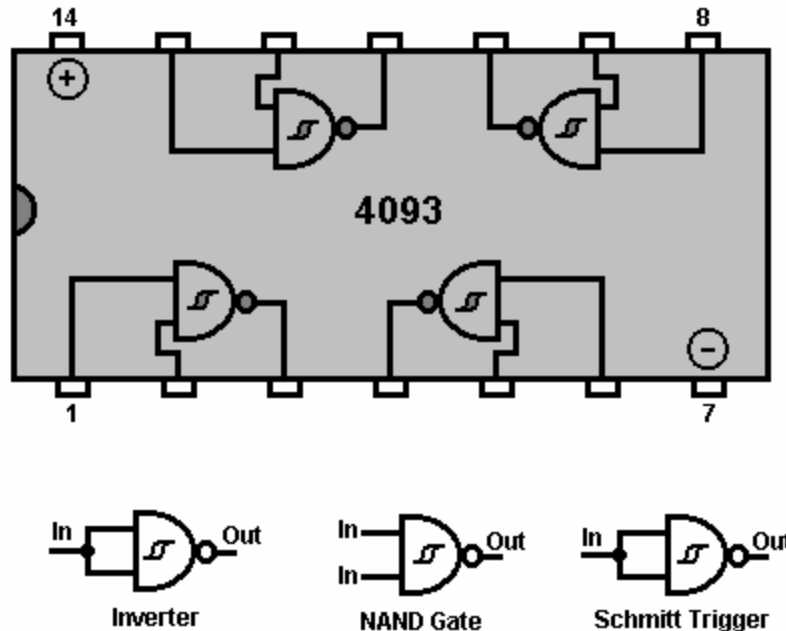

If the two inputs of a NAND gate are connected together, then the output will always be the opposite of the input, i.e. the gate acts as an inverter. This arrangement also works as a Schmitt Trigger due to the way the NAND gate circuitry is built. There are several packages built with this type of circuitry, the one shown here is the “74132” chip which contains four “dual-input” NAND gates. Gates can have almost any number of inputs but it is rare to need more than two in any given circuit. Another chip with identical pin connections is the **4011** chip (which is not a Schmitt circuit). This ‘quad dual-input’ NAND gate package uses a construction method called “CMOS” which is very easily damaged by static electricity until actually connected into a circuit. CMOS chips can use a wide range of voltages and take very little current. They are cheap and very popular

The number of devices built into an Integrated Circuit is usually limited by the number of pins in the package and one pin is needed for one connection to ‘the outside world’. Packages are made with 6 pins (typically for opto-isolators), 8 pins (many general circuits), 14 pins (many general circuits, mostly computer logic circuits), 16 pins (ditto, but not as common) and then a jump to large numbers of pins for Large Scale devices such as microprocessors, memory chips, etc. The standard IC package is small:

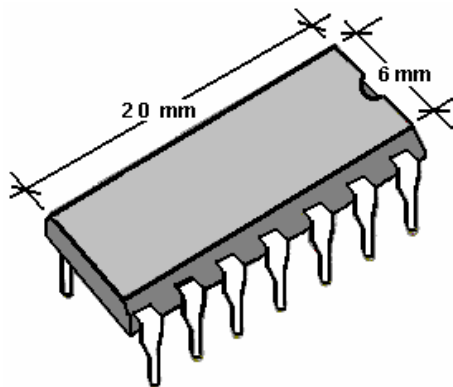

Prototype circuits are often built on ‘strip board’ which is a stiff board with strips of copper running along one face, and punched with a matrix of holes. The strips are used to make the electrical connections and are broken where necessary. This strip board is usually called “Veroboard”:

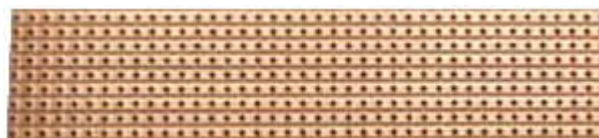

Nowadays, the strip board holes are spaced 2.5 mm (1/10”) apart which means that the gaps between the copper strips is very small indeed. I personally, find it quite difficult to make good solder joints on the strips without the solder bridging between two adjacent strips. Probably, a smaller soldering iron is needed. I need to use an 8x magnifying glass to be sure that no solder bridging remains in place before a new circuit is powered up for the first

time. Small fingers and good eyesight are a decided advantage for circuit board construction. The narrow spacing of the holes is so that the standard IC DIL package will fit directly on the board.

Circuits built using computer circuitry, can experience problems with mechanical switches. An ordinary light switch turns the light on and off. You switch it on and the light comes on. You switch it off and the light goes off. The reason it works so well is that the light bulb takes maybe, a tenth of a second to come on. Computer circuits can switch on and off 100,000 times in that tenth of a second, so some circuits will not work reliably with a mechanical switch. This is because the switch contact bounces when it closes. It may bounce once, twice or several times depending on how the switch is operated. If the switch is being used as an input to a counting circuit, the circuit may count 1, 2 or several switch inputs for one operation of the switch. It is normal to “de-bounce” any mechanical switch. This could be done using a couple of NAND gates connected like this:

The NAND Latch.

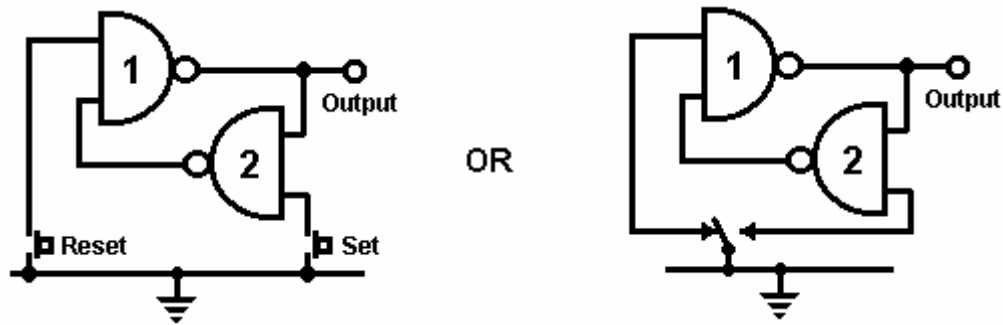

Here, the mechanical switch is buffered by a ‘latch’. When the ‘Set’ switch is operated, the output goes low. The unconnected input of gate ‘1’ acts as if it has a High voltage on it (due to the way the NAND gate circuit was built). The other input is held low by the output of gate ‘2’. This pushes the output of gate ‘1’ high, which in turn, holds the output of gate ‘2’ low. This is the first stable state.

When the ‘Set’ switch is operated, the output of gate ‘2’ is driven high. Now, both inputs of gate ‘1’ are high which causes its output to go low. This in turn, drives one input of gate ‘2’ low, which holds the output of gate ‘2’ high. This is the second stable state.

To summarise: pressing the ‘Set’ switch any number of times, causes the output to go low, once and only once. The output will stay low until the ‘Reset’ switch is operated once, twice or any number of times, at which point the output will go high and stay there.

This circuit uses just half of one cheap NAND gate chip to create a bistable multivibrator which is physically very small and light.

Gate Circuits.

NAND Gates can be used as the heart of many electronic circuits apart from the logic circuits for which the package was designed. Here is a NAND gate version of the rain alarm described earlier. The ‘4011B’ chip is a CMOS device which has a very high input impedance and can operate at convenient battery voltages (3 to 15 Volts):

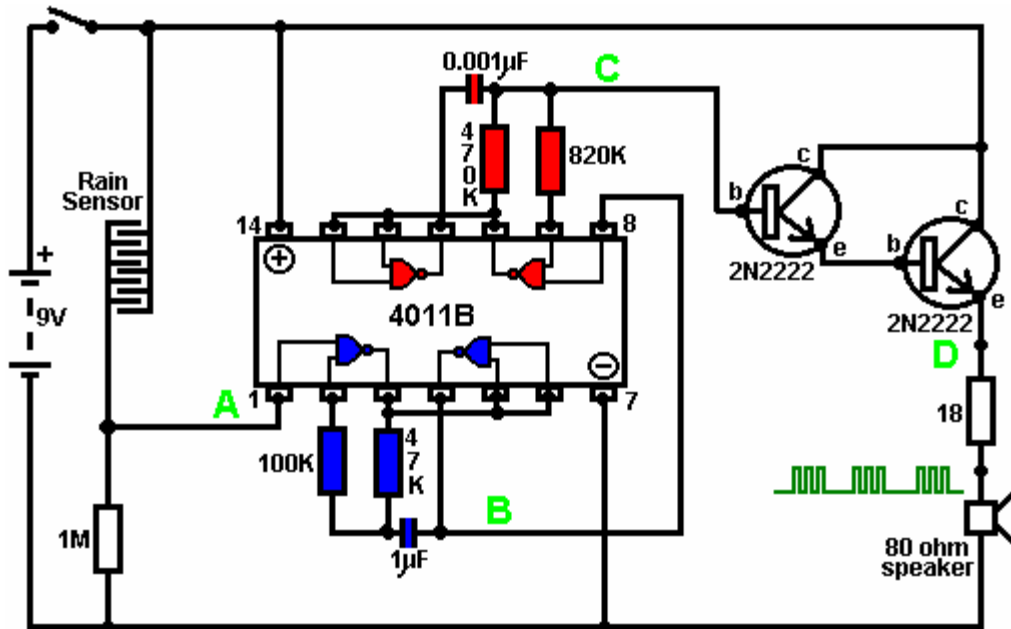

This circuit is comprised of a rain sensor, two astable multivibrators and a power-driver feeding a loudspeaker:

1. The rain sensor is a wired-up strip board or similar grid of interlaced conductors, forming a voltage-divider across the battery rails.
2. The output voltage from this, at point 'A' in the circuit diagram, is normally low as the strip board is open-circuit when dry. This holds the first NAND gate locked in the OFF state, preventing the first astable from oscillating. This first astable is colour-coded blue in the diagram. Its frequency (the pitch of the note it produces) is governed by the values of the 47K resistor and the 1 microfarad capacitor. Reducing the value of either of these will raise the frequency (note pitch). If rain falls on the sensor, the voltage at point 'A' goes high letting the astable run freely. If the voltage at 'A' does not rise sufficiently when it rains, increase the value of the 1M resistor.
3. The output of the first astable is a low voltage when the sensor is dry. It is taken from point 'B' and passed to the gating input of the second astable, holding it in its OFF state. The speed of the second astable is controlled by the value of the 470K resistor and the 0.001 microfarad capacitor. Reducing the value of either of these will raise the pitch of the note produced by the astable. The rate at which this astable operates is very much higher than the first astable.

When it rains, the voltage at point 'A' rises, letting the first astable oscillate. As it does so, it turns the second astable on and off in a steady rhythmic pattern. This feeds repeated bursts of high speed oscillations from the second astable to point 'C' in the diagram.

4. The Darlington-pair emitter-follower transistors cause the voltage at point 'D' to follow the voltage pattern at point 'C' (but 1.4 Volts lower voltage due to the 0.7 Volts base/emitter voltage drop for each transistor). The high gain of the two transistors ensures that the output of the second oscillator is not loaded unduly. These power-driver transistors place the output voltage across an eighty ohm loudspeaker, padded with a resistor to raise the overall resistance of the combination. The voltage pattern produced is shown at point 'D' and is an attention-grabbing sound.

So, why does this circuit oscillate?:

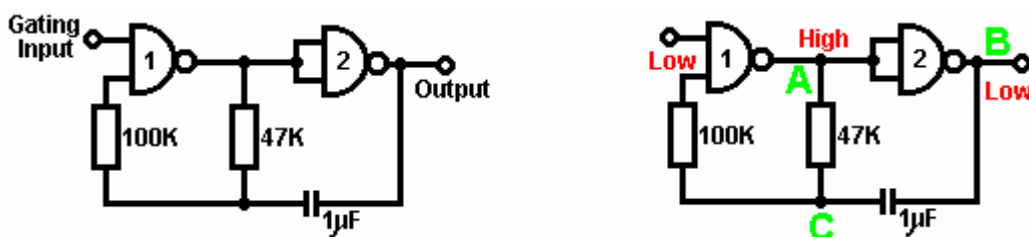

The circuit will not oscillate if the gating input is low, so assume it to be high. Take the moment when the output of gate 2 is low. For this to happen, the inputs of gate 2 have to be high. As the output of gate 1 is wired directly to the inputs of gate 2, it must be high, and for that to be true, at least one of its inputs must be low. This situation is

shown on the right.

There is now a full voltage drop between point 'A' and point 'B'. The 47K resistor and the capacitor are in series across this voltage drop, so the capacitor starts to charge up, progressively raising the voltage at point 'C'. The lower the value of the resistor, the faster the voltage rises. The larger the value of the capacitor, the slower the voltage rises.

When the voltage at point 'C' rises sufficiently, the 100K resistor raises the input voltage of gate 1 far enough to cause it to change state. This creates the following situation:

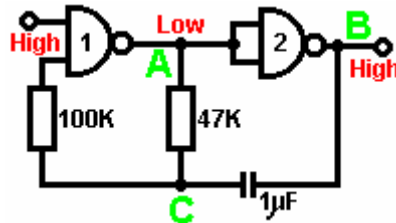

Now, the voltage across 'A' to 'B' is reversed and the voltage at point 'C' starts to fall, its rate governed by the size of the 47K resistor and the 1 microfarad capacitor. When the voltage at point 'C' falls low enough, it takes the input of gate 1 low enough (via the 100K resistor) to cause gate 1 to switch state again. This takes the circuit to the initial state discussed. This is why the circuit oscillates continuously until the gating input of gate 1 is taken low to block the oscillation.

Now, here is a NAND gate circuit for a sequential on/off switch:

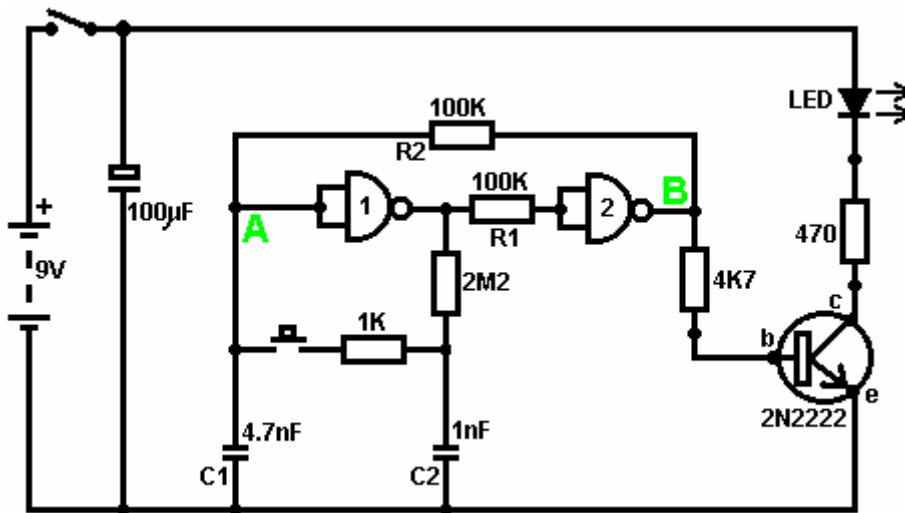

This circuit turns the Light Emitting Diode on and off repeatedly with each operation of the press-button switch. When the on/off switch is closed, capacitor 'C1' holds the voltage at point 'A' low. This drives the output of gate 1 high, which moves the inputs of gate 2 high via the 100K resistor 'R1'. This drives the voltage at point 'B' low, turning the transistor off, which makes the LED stay in its off state. The low voltage at point 'B' is fed back via the 100K resistor 'R2' to point 'A', keeping it low. This is the first stable state.

As the output of gate 1 is high, capacitor 'C2' charges up to that voltage via the 2M2 resistor. If the press-button switch is operated briefly, the high voltage of 'C2' raises the voltage of point 'A', causing gate 1 to change state, and consequently, gate 2 to change state also. Again, the high voltage at point 'B' is fed back to point 'A' via the 100K resistor 'R2', keeping it high, maintaining the situation. This is the second stable state. In this state, point 'B' has a high voltage and this feeds the base of the transistor via the 4.7K resistor, turning it on and lighting the LED.

In this second state, the output of gate 1 is low, so capacitor 'C2' discharges rapidly to a low voltage. If the press-button switch is operated again, the low voltage of 'C2' drives point 'A' low again, causing the circuit to revert to its original stable state.

We could, if we wished, modify the circuit so that it would operate for three or four minutes after switch-on but then stop operating until the circuit was turned off and on again. This is accomplished by gating one of the gates instead of just using both as inverters. If we gated the second gate, then the LED would be left permanently on,

so we will modify the first gate circuit:

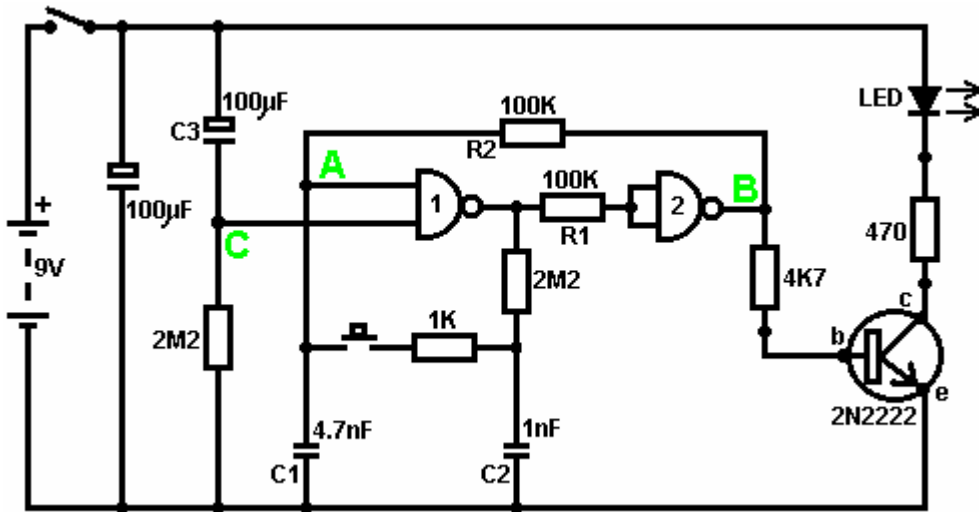

This circuit operates exactly the same way as the previous circuit if, and only if, the voltage at point 'C' is high. With the voltage at point 'C' high, gate 1 is free to react to the voltage at point 'A' as before. If the voltage at point 'C' is low, it locks the output of gate 1 at the high level, forcing the output of gate 2 to the low level and holding the LED off.

When the circuit is first powered up, the new 100 microfarad capacitor 'C3' is fully discharged, which pulls the voltage at point 'C' to nearly + 9 Volts. This allows gate 1 to operate freely, and the LED can be toggled on and off as before. As time passes, the charge on capacitor 'C3' builds up, fed by the 2M2 resistor. This causes the voltage at point 'C' to fall steadily. The rate of fall is governed by the size of the capacitor and the size of the resistor. The larger the resistor, the slower the fall. The larger the capacitor, the slower the fall. The values shown are about as large as are practical, due to the current 'leakage' of 'C3'.

After three or four minutes, the voltage at point 'C' gets driven low enough to operate gate 1 and prevent further operation of the circuit. This type of circuit could be part of a competitive game where the contestants have a limited time to complete some task.

The NAND Gate as an Amplifier.

Gates can also be used as amplifiers although they are not intended to be used that way and there are far better integrated circuits from which to build amplifiers. The following circuit shows how this can be done:

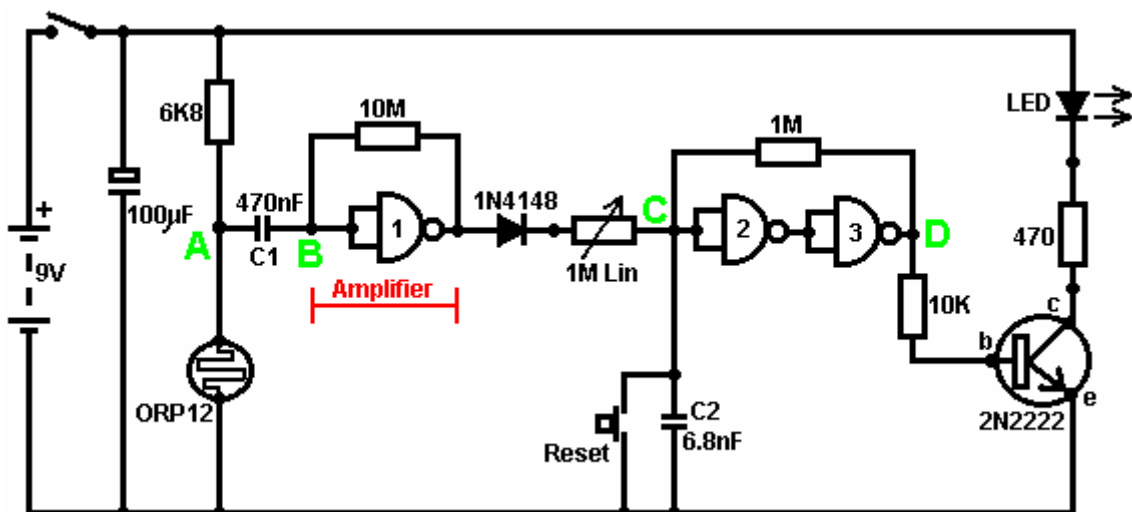

This circuit operates when there is a sudden change in light level. The previous light-level switching circuit was designed to trigger at some particular level of increasing or decreasing level of lighting. This is a shadow-detecting circuit which could be used to detect somebody walking past a light in a corridor or some similar situation.

The voltage level at point 'A' takes up some value depending on the light level. We are not particularly interested

in this voltage level since it is blocked from the following circuitry by capacitor 'C1'. Point 'B' does not get a voltage pulse unless there is a sudden change of voltage at point 'A', i.e. there is a sudden change in light level reaching the light-dependent resistor ORP12.

The first gate amplifies this pulse by some fifty times. The gate is effectively abused, and forced to operate as an amplifier by the 10M resistor connecting its output to its input. At switch-on, the output of gate 1 tries to go low. As its voltage drops, it starts to take its own inputs down via the resistor. Pushing the voltage on the inputs down, starts to raise the output voltage, which starts to raise the input voltage, which starts to lower the output voltage, which The result is that both the inputs and the output take up some intermediate voltage (which the chip designers did not intend). This intermediate voltage level is easily upset by an external pulse such as that produced by the ORP12 through capacitor 'C1'. When this pulse arrives, an amplified version of the pulse causes a voltage fluctuation at the output of gate 1.

This voltage change is passed through the diode and variable resistor to the input of gate 2. Gates 2 and 3 are wired together as a makeshift Schmitt trigger in that the output voltage at point 'D' is fed back to point 'C' via a high value resistor. This helps to make their change of state more rapid and decisive. These two gates are used to pass a full change of state to the output stage transistor. The variable resistor is adjusted so that gate 2 is just about to change state and is easily triggered by the pulse from amplifier gate 1. The output is shown as an LED but it can be anything you choose. It could be a relay used to switch on some electrical device, a solenoid used to open a door, a counter to keep track of the number of people using a passageway, etc. etc. Please note that an operational amplifier chip (which will be described later) is a far better choice of IC for a circuit of this type. A gate amplifier is shown here only to show another way that a gate can be utilised.

The NE555 Timer Chip.

There is an exceptionally useful chip designated by the number 555. This chip is designed to be used in oscillator and timer circuits. Its use is so widespread that the chip price is very low for its capability. It can operate with voltages from 5 Volts to 18 Volts and its output can handle 200 mA. It takes 1 mA when its output is low and 10 mA when its output is high. It comes in an 8-pin Dual-In-Line package and there is a 14-pin package version which contains two separate 555 circuits. The pin connections are:



This device can operate as a monostable or astable multivibrator, a Schmitt trigger or an inverting buffer (low current input, high current output).

Here it is wired as a Schmitt trigger, and for variation, it is shown triggering a triac which will then stay on until the circuit is powered down (an SCR could be used just as well with this DC circuit):

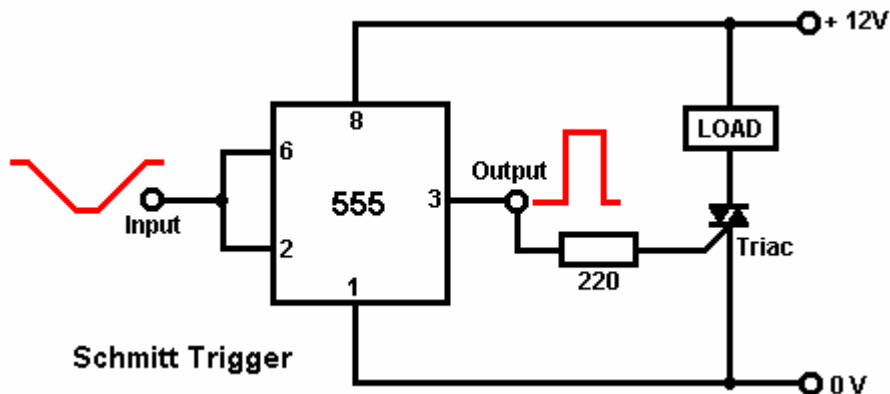

And here, a monostable:

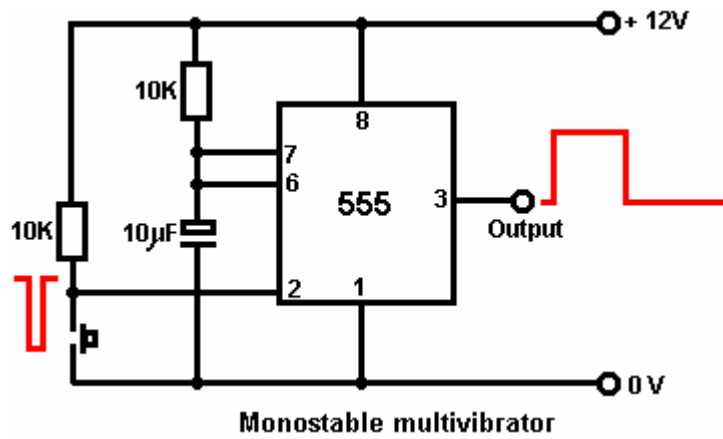

And here are two astables, the second of which has fixed, equal mark/space ratio and the first a high output voltage time determined by $R_a + R_b$ and a low voltage output time determined by R_b (2:1 in this case):

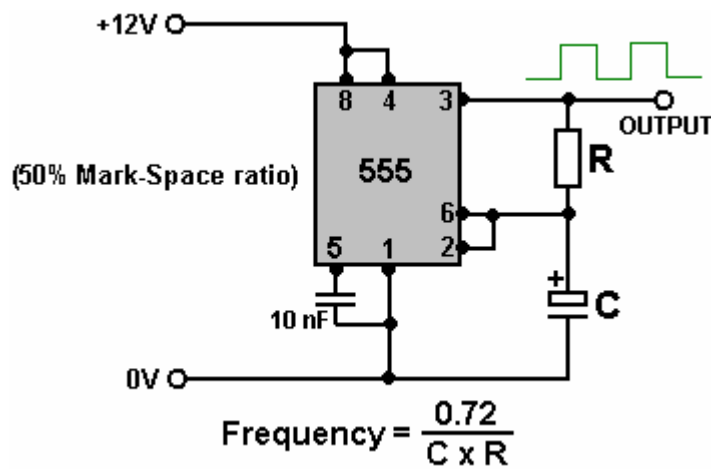
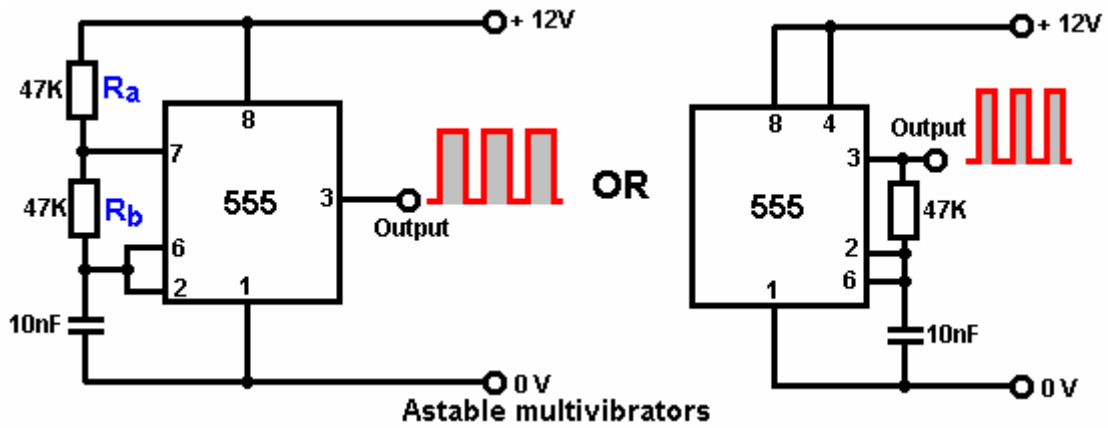

Astable Frequencies

	100	470	1K	4.7K	10K	47K	100K	470K	1M
0.1 μ F	72,000 Hz	15,319 Hz	7,200 Hz	1,532 Hz	720 Hz	153 Hz	72 Hz	15 Hz	7.2 Hz
0.47 μ F	15,319 Hz	3,259 Hz	1,532 Hz	326 Hz	153 Hz	33 Hz	15 Hz	3.3 Hz	1.5 Hz
1.0 μ F	7,200 Hz	1,532 Hz	720 Hz	153 Hz	72 Hz	15 Hz	7.2 Hz	1.5 Hz	1.4 secs
2.2 μ F	3,272 Hz	696 Hz	327 Hz	70 Hz	33 Hz	7 Hz	3.3 Hz	1.4 secs	3 secs
4.7 μ F	1,532 Hz	326 Hz	153 Hz	33 Hz	15 Hz	3.3 Hz	1.5 Hz	3 secs	6.7 secs
10 μ F	720 Hz	153 Hz	72 Hz	15 Hz	7.2 Hz	1.5 Hz	1.4 secs	6.7 secs	14 secs
22 μ F	327 Hz	70 Hz	33 Hz	7 Hz	3.3 Hz	1.4 secs	3 secs	14 secs	30 secs
47 μ F	153 Hz	33 Hz	15 Hz	3.3 Hz	1.5 Hz	3 secs	6.7 secs	30 secs	65 secs
100 μ F	72 Hz	15 Hz	7.2 Hz	1.5 Hz	1.4 secs	6.7 secs	14 secs	65 secs	139 secs
220 μ F	33 Hz	7 Hz	3.3 Hz	1.4 secs	3 secs	14 secs	30 secs	139 secs	307 secs
470 μ F	15 Hz	3.3 Hz	1.5 Hz	3 secs	6.7 secs	30 secs	65 secs	307 secs	614 secs
1,000 μ F	7.2 Hz	1.5 Hz	1.4 secs	6.7 secs	14 secs	65 secs	139 secs	614 secs	
2,200 μ F	3.3 Hz	1.4 secs	3 secs	14 secs	30 secs	139 secs	307 secs		
4,700 μ F	1.5 Hz	3.3 secs	6.7 secs	30 secs	65 secs	307 secs	614 secs		
10,000 μ F	1.4 secs	6.7 secs	14 secs	65 secs	139 secs	614 secs			

Note: The high leakage of large value electrolytic capacitors prevents them being used with high value resistors in timing circuits. Instead, use a smaller capacitor and follow the timing circuit with a “divide-by-N” chip to give accurately timed long periods. Not all 555 chips have a manufacturing quality sufficient for them to operate reliably above 20,000 Hz, so for the higher frequencies the chip needs to be selected after testing its actual performance.

We can also wire the 555 to give a variable mark/space ratio while holding the frequency of the oscillation fixed:

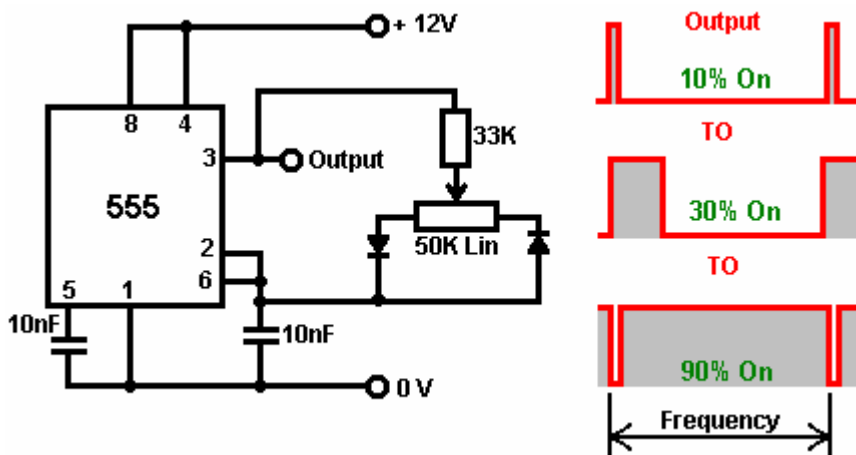

The output waveform changes drastically as the variable resistor is adjusted, but the frequency (or pitch of the note) of the output stays unaltered.

A variable-frequency version of this circuit can be produced by changing the 33K resistor to a variable resistor as shown here:

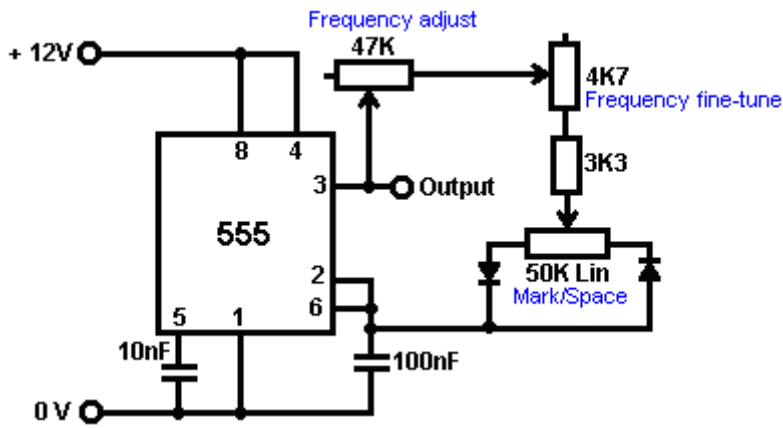

Here, the 33K resistor has been replaced by two variable resistors and one fixed resistor. The main variable resistor is 47K in size (an almost arbitrary choice) and it feeds to a second variable resistor of 4.7K in size. The advantage of this second variable resistor is that it can be set to its mid point and the frequency tuning done with the 47K variable. When the frequency is approximately correct, the 4.7K variable can be used to fine tune the frequency. This is convenient as the small variable will have ten times more knob movement compared to the main variable (being just 10% of its value).

Obviously, it is not necessary to have the fine-tuning variable resistor, and it can be omitted without changing the operation of the circuit. As the 47K variable resistor can be set to zero resistance and the 4.7K variable resistor can also be set to zero resistance, to avoid a complete short-circuit between output pin 3 and the 50K Mark/Space variable resistor, a 3.3K fixed resistor is included. In this circuit, the frequency is set by your choice of the resistor chain 47K + 4.7K + 3.3K (adjustable from 55K to 3.3K) and the 100nF (0.1 microfarad) capacitor between pin 6 and the zero volt rail. Making the capacitor larger, lowers the frequency range. Making the resistors larger, also lowers the frequency range. Naturally, reducing the size of the capacitor and/or reducing the size of the resistor chain, raises the frequency.

One 555 chip can be used to gate a second 555 chip via its pin 4 'Reset' option. You will recall that we have already developed a circuit to do this using two astables and a transistor. We also generated the same effect using four NAND gates. Here, we will create the same output waveform using the more conventional circuitry of two 555 chips:

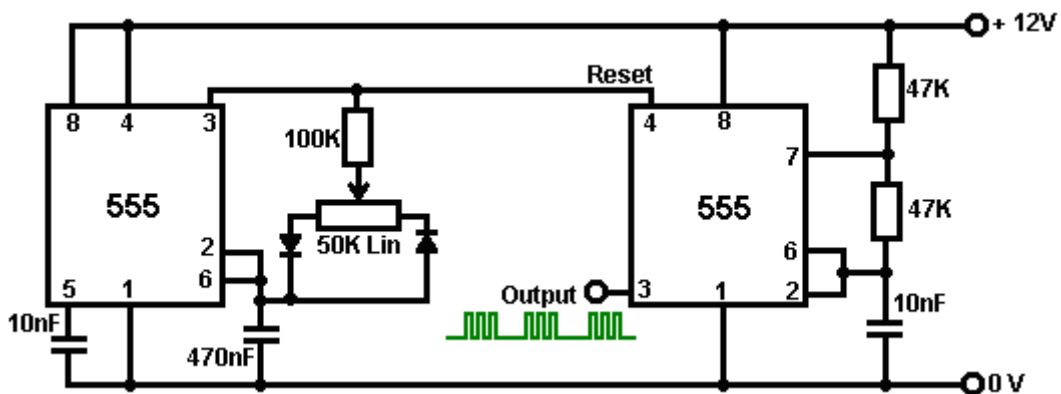

Both of the NE555 circuits can be bought in a single 14-pin DIL package which is designated 'NE556':

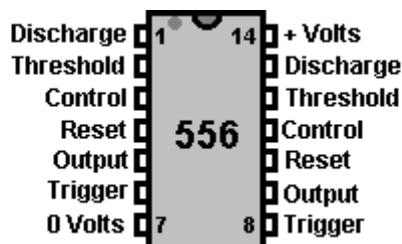

555 8-pin	555 No.1	555 No.2
2	6	8
3	5	9
4	4	10
5	3	11
6	2	12
7	1	13

There are many additional circuit types which can be created with the 555 chip. If you wish to explore the possibilities, I suggest that you download the free pdf "50 555 Projects" from the web site:

The 555 chip can also produce a sine wave output:

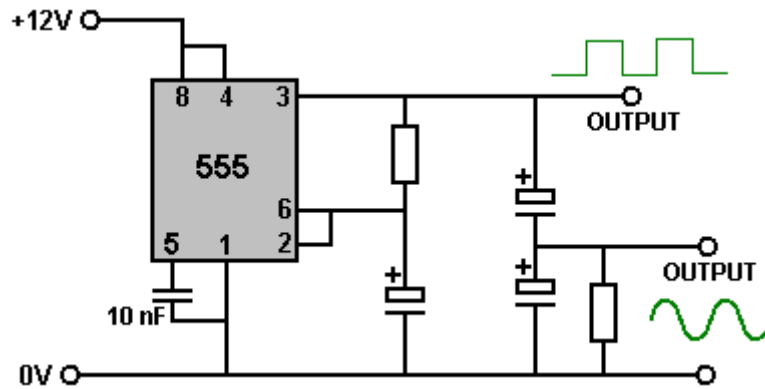

Or, if you wish, a bi-stable multivibrator:

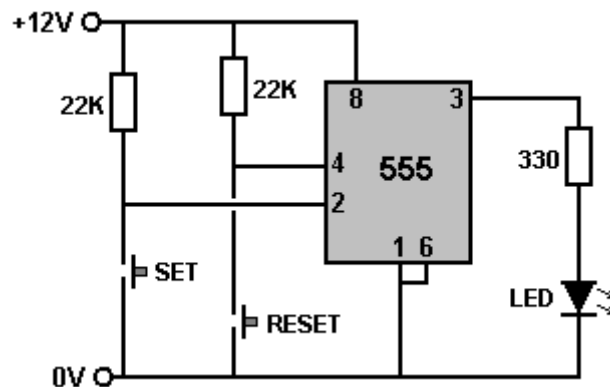

All right, suppose that we want to design and build a circuit to do the same as Bob Beck's pulser circuit mentioned in chapter 11. The requirements are to produce a square wave output pulsing four times per second using a 27 volt power supply, the circuit being powered by three small PP3 size batteries. An obvious choice for the circuit seems to be a 555 timer chip which is small, robust and cheap and a suitable circuit would appear to be:

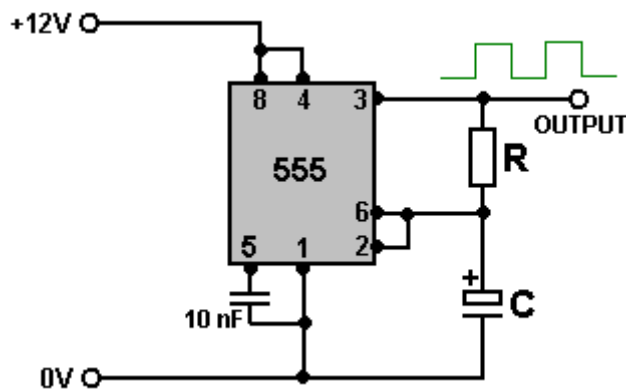

This leaves us with choosing a value for the capacitor and the resistor. We need to pay attention to the fact that the circuit will be running on 27 volts and while the capacitor will not charge up to anything like that voltage, we still will pick one which will survive 27V. Looking on the local eBay shows that a pack of ten capacitors of 1 microfarad rated at 50V can be bought for just £1 including postage, so take that as the value for "C". Looking at the 555 table of frequencies above shows:

Astable Frequencies

	100	470	1K	4.7K	10K	47K	100K	470K	1M
0.1 μF	72,000 Hz	15,319 Hz	7,200 Hz	1,532 Hz	720 Hz	153 Hz	72 Hz	15 Hz	7.2 Hz
0.47 μF	15,319 Hz	3,259 Hz	1,532 Hz	326 Hz	153 Hz	33 Hz	15 Hz	3.3 Hz	1.5 Hz
1.0 μF	7,200 Hz	1,532 Hz	720 Hz	153 Hz	72 Hz	15 Hz	7.2 Hz	1.5 Hz	1.4 secs

Which indicates that to get the circuit switching four times per second (4 Hz) the resistor “R” will need to be somewhere between 100K and 470K. With my capacitor, 120K is about right.

While the switching frequency does not have to be exact, let’s aim at getting it correct. Most reasonably priced components have a tolerance of around 10% so we need to select our resistor/capacitor combination for the exact values of the actual components which we will use. For this, it is worth building the circuit on a solder-less ‘breadboard’, so looking on eBay again we find that a suitable small plug-in board can be bought and delivered for £3. It looks like this :

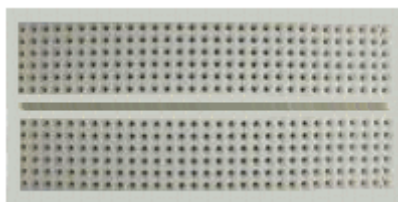

These type of boards allow ICs to be plugged in spanning the central divide, leaving up to five extra connections on every pin. Short lengths of solid-core wire can be used to connect between any two socket holes. This will allow us to plug in one of our capacitors and find what resistor (or what two resistors) make the circuit switch forty times in ten seconds.

However, if we go to <http://www.alldatasheet.co.kr/> and download the data pdf for the NE555 chip, we find that the maximum 555 chip voltage is quite limited:

DC AND AC ELECTRICAL CHARACTERISTICS

$T_A = 25^\circ\text{C}$, $V_{CC} = +5\text{V}$ to $+15$ unless otherwise specified.

SYMBOL	PARAMETER	TEST CONDITIONS	SE555			NE555/SE555C			UNIT
			Min	Typ	Max	Min	Typ	Max	
V_{CC}	Supply voltage		4.5		18	4.5		16	V
I_{CC}	Supply current (low state) ¹	$V_{CC}=5\text{V}$, $R_L=\infty$ $V_{CC}=15\text{V}$, $R_L=\infty$		3	5		3	6	mA
				10	12		10	15	mA

This means that the chip is liable to burn out instantly if it is fed more than 16 volts. As we need to run our circuit on 27V this is a problem. As the 27V is being provided by three separate batteries, we could supply the 555 chip from just one of the batteries and run it on 9V which would be ok from the point of view of the chip as the table above shows that it can operate correctly with a supply voltage as low as 4.5 volts. The disadvantage of that arrangement is that one of the batteries will run down more quickly than the others and it would be nice to avoid that.

The table also shows that the current draw just to keep the 555 running can be anything from 6 to 15 milliamps. That is not a large current but the PP3 batteries have been chosen for their small size, allowing the whole circuit to be strapped to a person’s wrist. A quick search on the internet shows that cheap PP3 batteries have a capacity of 400 milliamp-hours and the very expensive alkaline types 565 milliamp-hours. These ratings are the “C20” values, based on the battery being discharged at a constant current over a period of twenty hours, which would be ten days of use if Bob Beck’s two hours per day protocol is followed.

This means that the ‘cheap’ batteries should not be discharged at more than one twentieth of their 400 mAHr rating, which is 20 mA. The expensive alkaline batteries should be able to be discharged at 28 mA for twenty hours.

Our current draw is made up of two parts. The first part is supplying the circuit with the current which it needs to run. The second part is the current flowing through the body of the user. This second part is limited by the 820

ohm resistor in the output line which limits that part of the current to a maximum of 33 milliamps (Ohm's Law: Amps = Volts /Resistance). This neglects the body resistance and assumes that the output control variable resistor is set to minimum resistance, which is unlikely.

Checking these values shows that the 555 chip is liable to draw as much current as the circuit supplies through the output electrodes. However, let's go ahead with the circuit, after all, we might decide to use rechargeable PP3 batteries which would overcome the need to buy new batteries every few days.

The first essential requirement is to provide the 555 chip with a voltage of, say, 10 volts when it is running in the completed circuit. That could be done with one of the voltage-stabiliser integrated circuits:

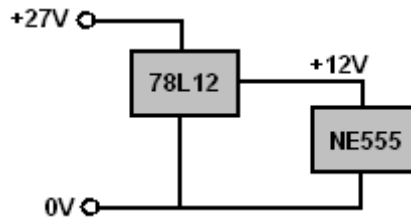

That is not a particularly expensive option, but those chips draw a current in order to provide the voltage stabilisation and an absolutely steady voltage is not needed by the 555 chip. Alternatively, we could use a resistor and a 10V zener diode:

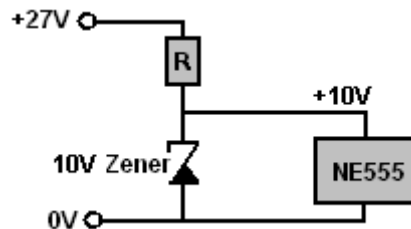

But that method does waste some current flowing through the zener in order to provide the wanted voltage. The most simple method is to use a resistor and a capacitor:

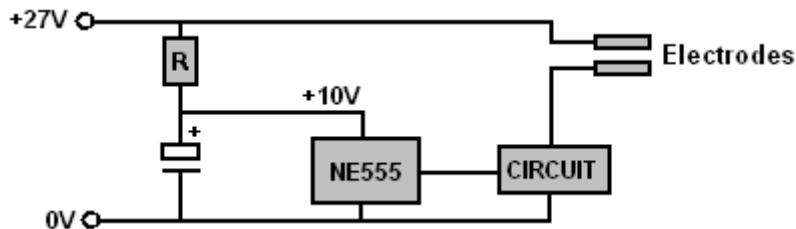

Considerable care is needed when selecting the resistor value "R". If the value is too low, then the voltage passed to the 555 chip will be too high and the chip will burn out. When selecting the resistor "R", start with a higher value than expected and then substitute slightly lower value resistors while monitoring the voltage across the capacitor to make sure that it stays low enough. The resistor value can be assessed using Ohm's Law. Assuming a current of about 6 mA, the voltage drop across the resistor being $(27 - 10) = 17$ volts, then a resistor of about 2.83K (as Ohms = Volts / Amps) which suggests that starting with a 4.7K resistor is likely to be ok, and then picking each lower standard resistor in turn until a satisfactory voltage across the capacitor is reached.

The capacitor could be 12V or 15V rated, but if one rated at a higher voltage is used, then if it is accidentally connected across the full 27V it will not be harmed in any way. The larger the capacitance, the better, say 220 microfarads which can be got for a few pence on eBay. If you want to play safe, you could connect a 12V zener diode across the capacitor. It will not draw any current under normal working conditions, but if anything should cause the voltage on the capacitor to rise, then it will fire up and hold the voltage down to a safe 12V level. I would be inclined to see the zener as being unnecessary, but the choice is always yours.

So what resistor power rating is needed? Well, if the resistor turns out to be a 2.7K and the capacitor voltage ends up as 9.5 volts, then the average voltage across the resistor is 17.5V which makes the current through it 6.48 mA and as Watts = Volts x Amps, the power rating needs to be 113 milliwatts, so the typical quarter-watt (250 mW) resistor should be perfectly ok. If two (nearly equal value) resistors in parallel are used to get some intermediate value of "R" then that increases the overall resistor wattage.

The output of the 555 chip is then used to drive the remainder of the circuit which operates at 27V. A BC109C transistor costs only a few pence, can handle the voltage and has a minimum gain of 200 although the gain can be anything up to 800 and a BC109 can handle the current quite easily. If you need to find out any of these things, then download a datasheet for the transistor from the internet.

The output of the 555 timer is on pin 3 and it can easily supply 200 mA which is far, far more current than we would ever need for this circuit. We can feed the 555 square-wave output to the 27V electrodes using a transistor:

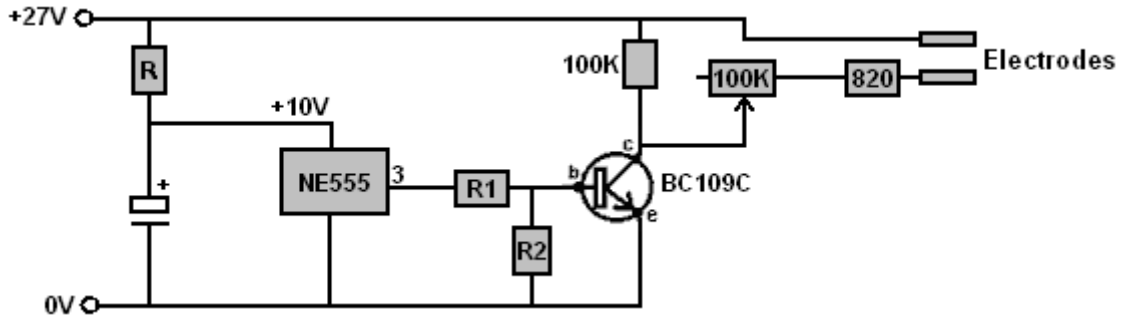

As the transistor is made of silicon, the switch-on voltage is when the base voltage is about 0.7 volts above the emitter voltage. That means that when the transistor is switched on, the top of resistor "R1" will be at around 10 volts and the bottom of "R1" will be at about 0.7 volts, which means that the voltage across "R1" will be $(10 - 0.7) = 9.3$ Volts. When that voltage is present across "R1" we want it to feed sufficient current to the transistor to switch it on fully. The transistor supplies a 100K resistor (which will carry 0.27 mA when 27 volts is across it) and the electrodes which will have a minimum resistance of 820 ohms across them (causing a current of 33 mA through them). So, the transistor might have to supply about 33 mA maximum. The BC109C transistor has a minimum gain of 200 so the current flowing into the base needs to be $33 / 200 = 0.165$ mA and the resistor which will carry that current when it has 9.3 volts across it is 56.3K. A somewhat smaller resistor will suit.

A commonsense check that the resistor calculation is correct is:

A 1K resistor carries 1 mA per volt and so will carry 9.3 mA with 9.3 volts across it.

A 10K resistor will carry one tenth of that amount, or 0.93 mA with 9.3 volts across it.

A 100K resistor will carry one tenth of that again, or 0.093 mA with 9.3 volts across it.

This indicates that for a current of 0.165 mA which is about twice the 100K current, a resistor of about half of 100K should be about the right value, so 56.3K looks correct.

Considering that the gain of 200 is the minimum and three or four times that is typical, we could perhaps choose to use a 47K resistor for "R1"

As the electrode current is likely to be considerably less than 33 mA and as the BC109C gain is likely to be very high, it could be quite difficult to get the transistor to switch off as it can operate on very tiny amounts of input current. To get it to switch on and off cleanly when the 555 output voltage is say, about 5 volts, (at which point the NE555 voltage will be changing very rapidly), "R2" is included. With it in place, the output voltage of the NE555 is divided between "R1" and "R2" in the ratio of their resistances. The situation we want is:

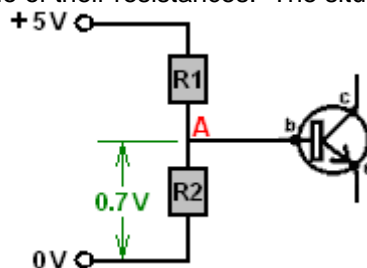

When The transistor is not switched on, it draws almost no current and so looks like a very high value resistor to the circuit. This allows the "R1" and "R2" resistors to act as a voltage-divider pair. This causes the voltage at point "A" to be determined by the ratio of "R1" to "R2" and the transistor can be ignored provided that the voltage at point "A" is below 0.7 volts. If the voltage at that point rises to 0.7 volts then the situation changes dramatically and Ohm's Law no longer holds as the transistor is not a passive resistor but instead, is an active semi-conductor device. If the voltage at point "A" tries to rise further it can't because the transistor base clamps it solidly there by appearing to be an ever lower resistor between the base and the emitter of the transistor. So for higher input voltages, resistor "R2" might as well not be there for all the difference it makes.

So, what value do we need for "R2" in order for the voltage at point "A" to be 0.7V when pin 3 of the NE555 reaches 5V? Well, that part of the circuit is acting in a resistive fashion and so Ohm's Law can be used. The resistor "R1" is 47K and has 4.3 volts across it, which means that the current through it must be 0.915 mA. That means that "R2" has 0.7V across it and 0.915 mA flowing through it which means that it has a value of 7.65K. A standard 8.2K or 6.8K resistor could be used as there is nothing dramatically important about the 5V switching point. If you were fussed about getting exactly 7.65K (and you shouldn't be), then you can get that value by combining two standard resistors, either in series or in parallel.

A common sense method of working out the value of "R2" is to use the fact that as the same current flows through them (no matter what that current happens to be), then the ratio of the voltage will be the same as the ratio of the resistors. That is: $0.7V / 4.3V = "R2" / 47K$ or $"R2" = 47K \times 0.7 / 4.3$ which is 7.65K.

We have now reached the point where we can determine the resistor value needed to provide a reasonable voltage for the NE555 timer chip, the circuit being:

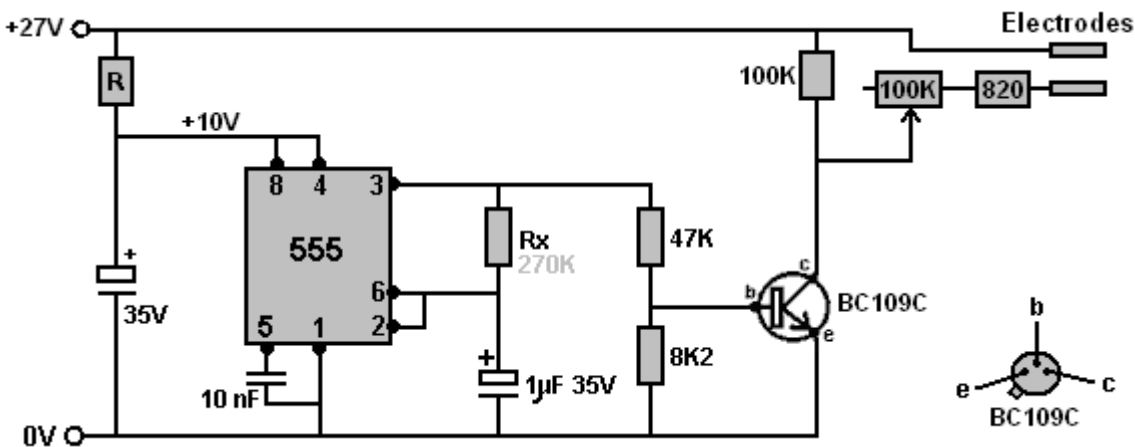

The "Rx" value is going to be fairly close to 270K so you can use that value when testing to find a suitable value for "R" (2.2K in my case). The capacitor across the NE555 chip should be as large a capacitance as is convenient, bearing in mind that the entire circuit, batteries, etc. is to fit into a small case to be strapped to a wrist. One way that the components could be positioned on the plug-board is:

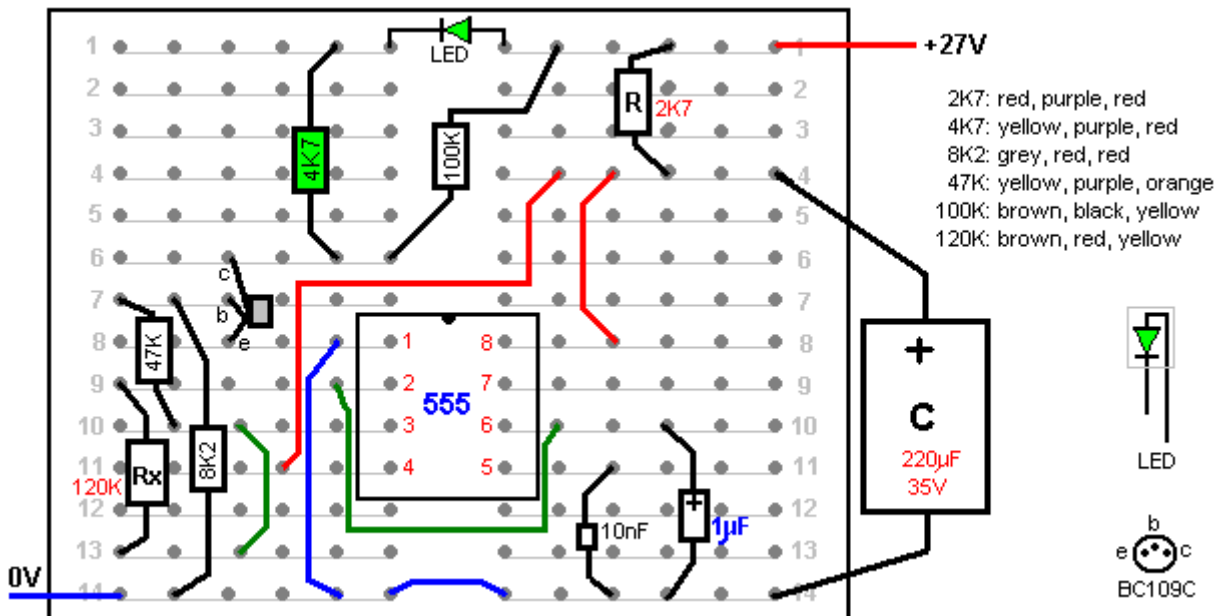

Remember that when trying various resistors for "R" you need to start high at about 4.7K and the resulting voltage on the capacitor shows the voltage drop across your first resistor choice and so, the actual current being drawn by your particular NE555 chip. That calculated current will allow you to calculate the resistor value needed to give 10 volts or so, allowing your next resistor to be tested to be almost exact in value.

For checking the frequency produced by the circuit, any ordinary LED can be used as a temporary measure. It can be connected across the 100K 'load' resistor between the transistor collector and the +27V positive supply

line. A current-limiting resistor is essential to stop the LED burning out instantly. If we allow a current of 5 mA to flow through the LED then since the current-limiting resistor has some 26.3 volts across it, then it's value will be about 5.4K (1K would give 26 mA, 2K would give 13 mA, 3K would give 9 mA, 4K would give 6.5 mA) and so a 4.7K resistor works well. This LED and resistor are shown in the layout above. Please remember that if your BC109C transistor has a metal case, then that case is normally connected internally to the collector and so, care must be taken that the case does not short-circuit to anything else.

If it is considered important to maximise battery life by reducing the current draw to a minimum, then perhaps using an astable circuit might be a good choice. In common with most electronic circuits, there are many different ways to design a suitable circuit to do the required job. The BC109C transistor can handle the 27V and so we might aim at a current draw for the circuit of just 3 mA. If 2 mA were to flow through the astable transistors when they are switched on, then with 27V across them, the resistors would be 13.5K which is not a standard value. We might select 12K to give a 2.25 mA current, or 15K to give 1.8 mA. Either should be satisfactory. The circuit might then be:

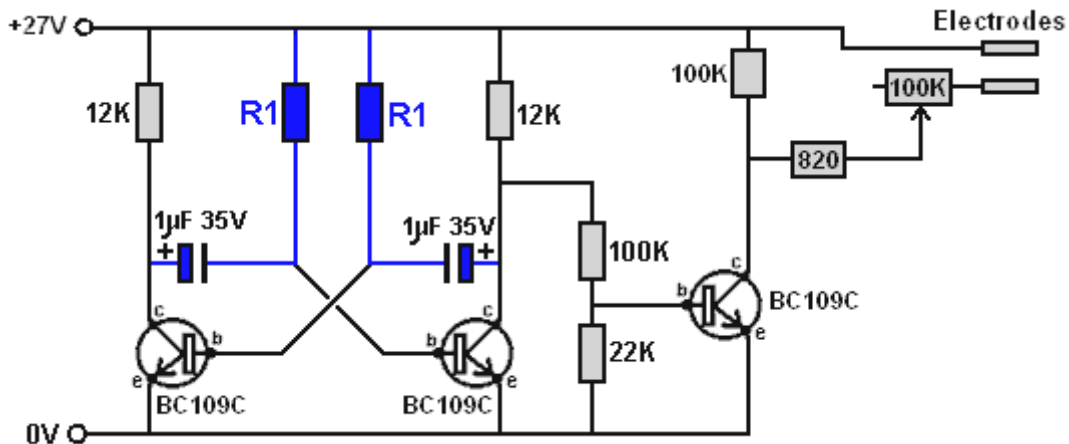

As the voltage swing feeding the output transistor has now risen from 10V to 27V the voltage-divider resistors can now increase in value by 2.7 times, giving around 127K and 22.1K for these resistors. However, the situation is not the same as for the NE555 chip which can supply at least 200 mA at the voltage-high output level. Instead, the transistor becomes such a high resistance that it can be ignored, but the 12K remains in the path which supplies the base current for the output transistor and it will in fact, add to the upper resistor of the voltage-divider pair. So while a 100K resistor is shown, it is effectively 112K due to that extra 12K resistor between it and the +27V supply line. The astable transistors will be switching fast at the point where the output transistor changes state, so the output square wave should be good quality. The BC109C transistor can switch on and off a hundred million times per second, so it's performance in this circuit should be very good. A test breadboard layout might be:

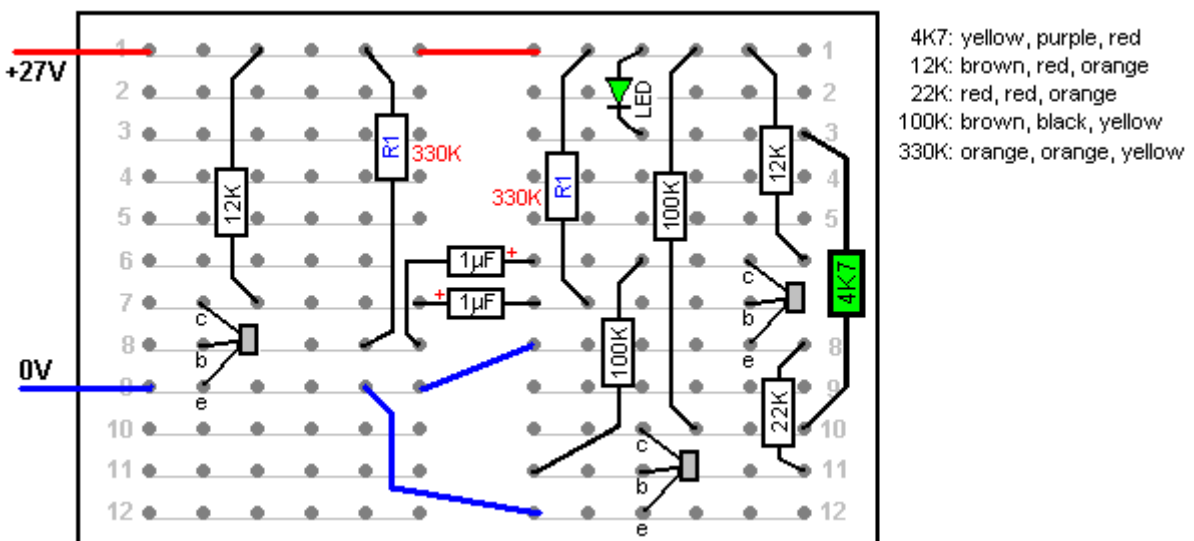

We now need to choose the timing components. For an even 50% duty cycle where each transistor is ON for half the time and OFF for half the time, the two timing capacitors can be the same size and then the two timing resistors will have the same value, in my case, 330K but it depends on the actual capacitors used.

Bob Beck's design calls for the LED display to be running when the unit is switched on and then be disconnected when the electrodes are plugged into a 3.5 mm socket mounted on the case containing the circuit. The switched socket looks like this:

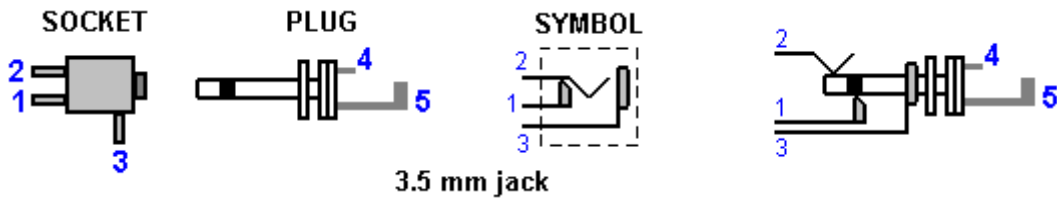

When the plug is not inserted into the socket, pin 1 connects to pin 2 and pin 3 is not connected to anything. When the plug is inserted, then pin 1 is isolated, pin 2 is connected to plug pin 4 and pin 3 is connected to plug pin 5.

The Beck circuit is connected to the output socket like this:

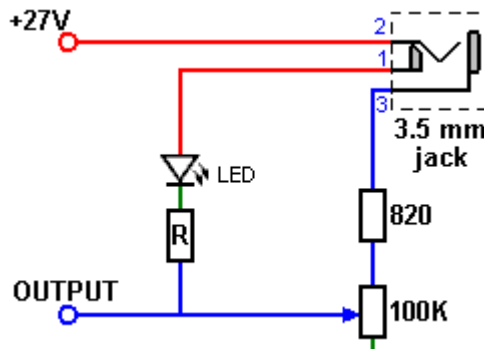

This arrangement will give a 27V 4Hz square wave output through the jack socket. But, Bob Beck's original circuit did not do that. Instead, it was like this:

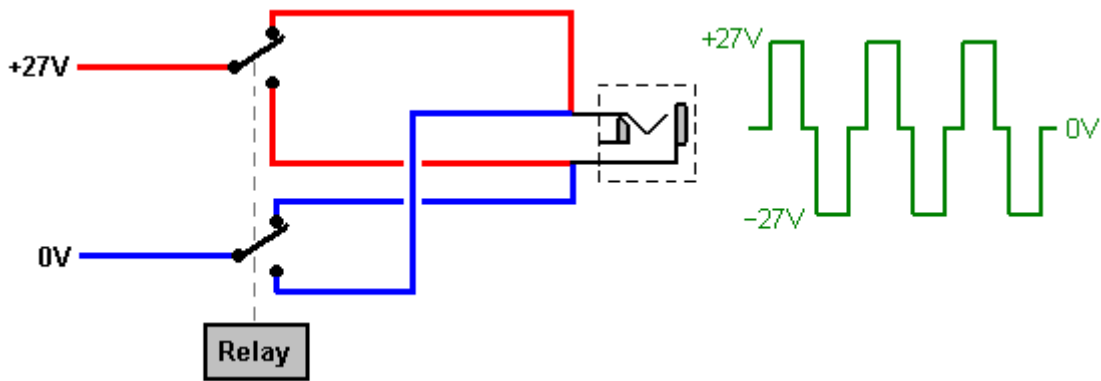

Here, a relay operates two change-over switch contacts which are used to reverse the battery bank contacts four times per second. That is different from just producing a positive-going square wave voltage between the two output terminals. If you were to consider a resistor connected across the output socket, then with the relay switching, the direction of the current reverses four times per second, but with the square wave, while it starts and stops four times per second, the direction of the current is always the same and there is no reversal of direction.

As Bob wanted to avoid using a relay which clicks four times per second all the way through the two-hour treatment described in chapter 11 and in the "Take Back Your Power" pdf on the <http://www.free-energy-info.tuks.nl/> web site, he redesigned the circuit using the very impressive LM358/A integrated circuit:

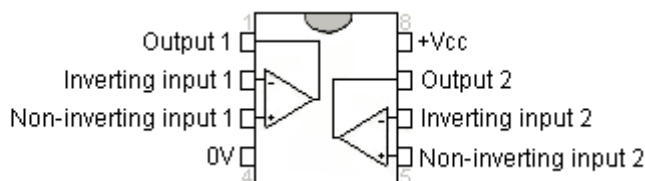

This chip draws only half of one milliamp, has two very high-gain operational amplifiers and can operate with a wide range of supply voltages. It is also inexpensive.

Bob displays the circuit as:

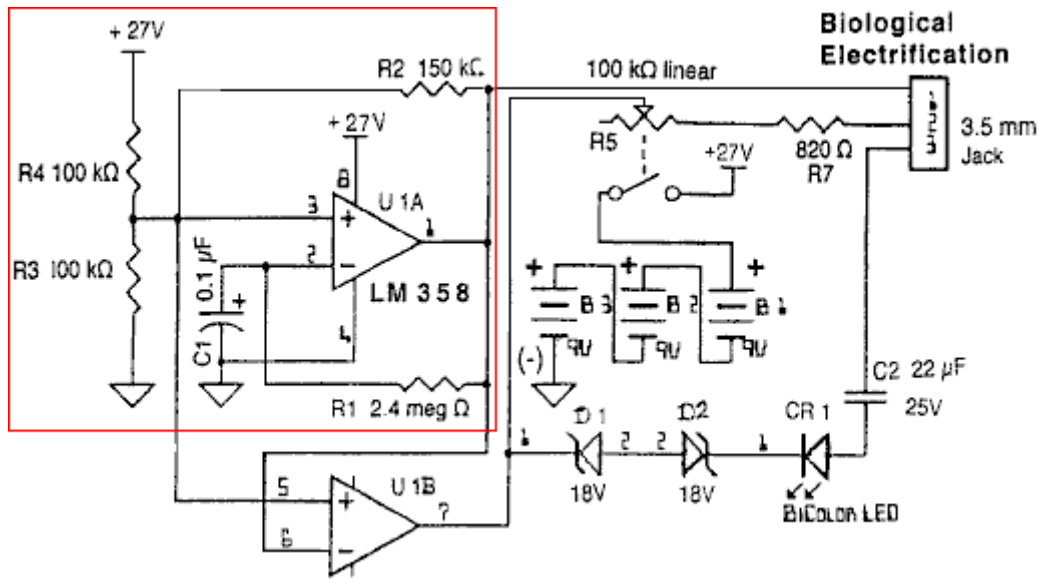

Bob states that the first section acts as a 4Hz square-wave signal generator, the frequency being controlled by the 2.4M resistor "R1" and the 100nF capacitor "C1". The data sheet for the LM358 states that the output voltage swing is between zero volts and 1.5V less than the supply voltage "Vcc" (which is +27V in this case). That implies that, as would be expected, the pin 1 output voltage from the first stage will switch sharply from 0V to +25.5V and sharply back again, four times per second.

It is difficult to follow the circuit as it is drawn, so it might be a little easier to follow when drawn like this:

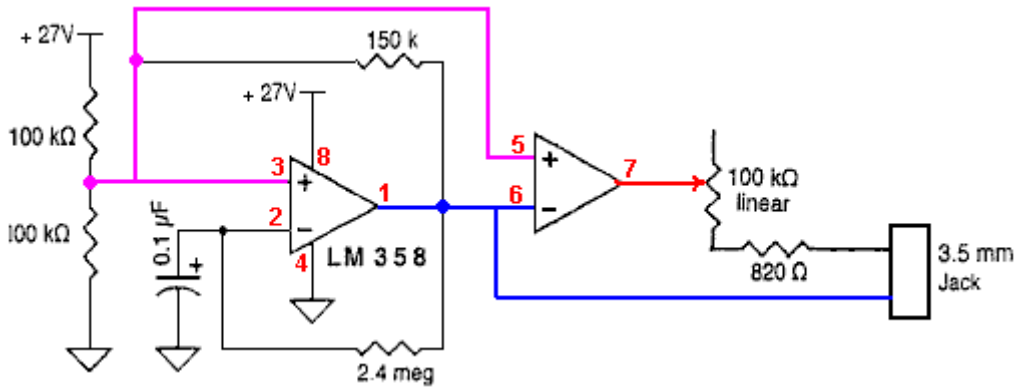

The output from the first amplifier inside the LM358 package is on pin 1 and it can supply a large amount of current (if a large current is ever needed). That output goes straight to one of the jack socket connections. It also goes to the pin 6 input of the second amplifier inside the chip and that causes the high-power output of that amplifier on pin 7 to be the opposite of the pin 1 voltage. When pin 1 goes high to +25.5 volts, then pin 7 goes low, to about zero volts. That output is also fed to the other jack socket connection, placing 25.5 volts across the electrodes when they are plugged in to the jack socket.

When the oscillator circuitry connected to the first amplifier causes the voltage on pin 1 to go low, then the output on pin 7 inverts it and so it goes to +25.5 volts. You will notice that while the overall voltage of 25.5 volts is applied again to the jack socket, the polarity is now reversed, achieving what the relay circuit does (although 1.5 volts is lost in the process). This is a neat solution.

Bob uses a two-colour LED to confirm that the circuit is working correctly before the electrodes are plugged in. He chooses to do it this way:

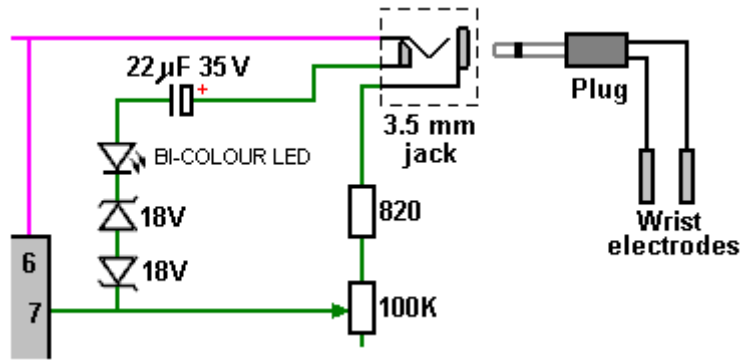

The two 18V zener diodes drop off 18.7 of the 25.5 volts as one will be forward biased dropping 0.7 volts and the other reversed biased, dropping off 18 volts. That leaves a 7V drop for the LED, which is a bit excessive, so Bob says that he uses a capacitor to limit the current. As there is already an 820 ohm resistor in the LED current path through the socket, the capacitor is not needed. The variable resistor need to be set to it's minimum resistance by rotating it's shaft fully clockwise so that it does not affect the LED brightness as the zeners also show when the battery voltage has dropped as there will no longer be sufficient voltage to light the LED brightly, indicating that the batteries need to be replaced (or recharged if they are rechargeable batteries). When testing the circuit, an alternative to the two zeners is to use a 4.7K resistor and if a bi-colour LED is not to hand, then two ordinary LEDs can be used back to back like this:

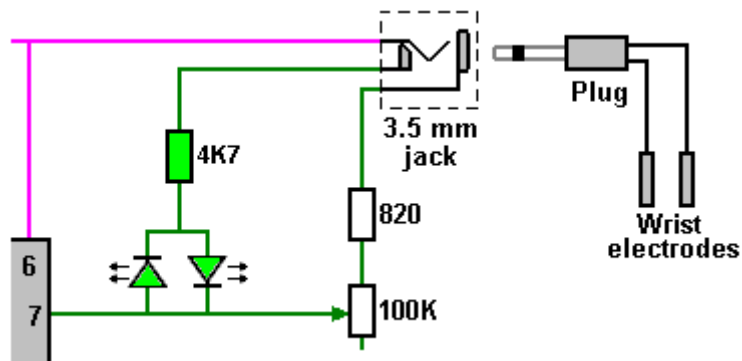

With this arrangement, the two LEDs flash alternately. In any circuit, a capacitor with a higher voltage rating can always be used if the capacitance values are the same. The Beck external circuit is completed through the body of the user, so there is just one electrode connected to each side of the output jack socket. A possible plug-board layout is:

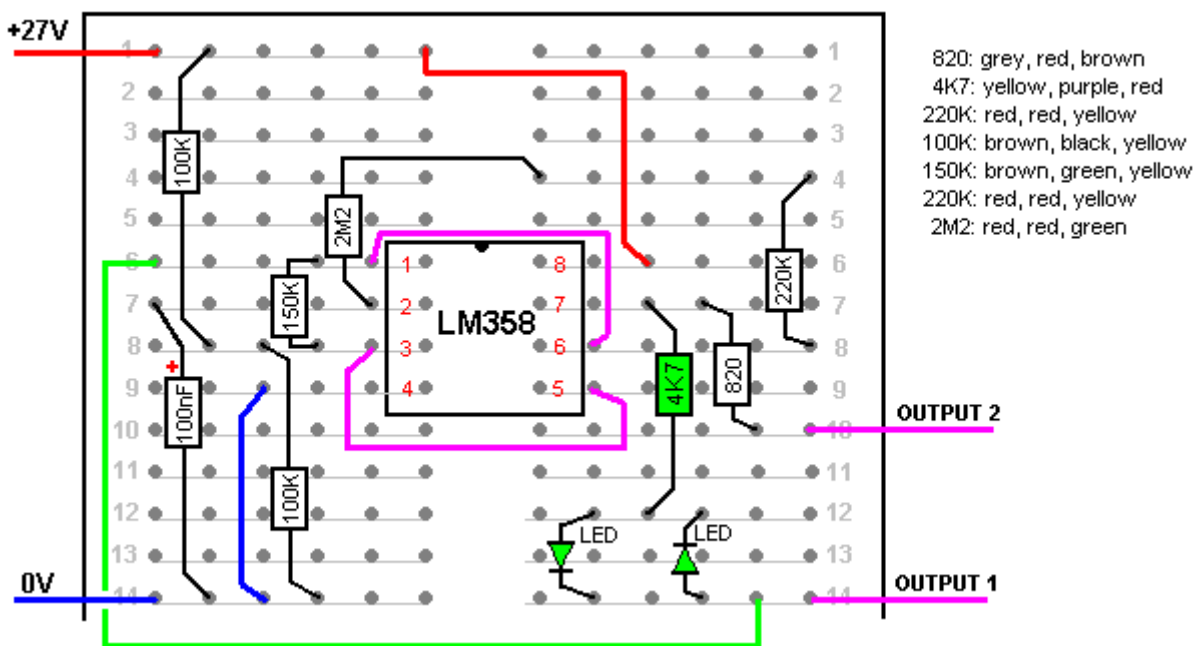

The 4.7K resistor and LEDs are only on the board for testing purposes and when the circuit is built in permanent form, then the LED chain connects to pin 1 of the jack socket so that the LEDs are disconnected during the two hours of daily treatment recommended when using the device.

One stripboard layout using the standard 9-strip 25-hole board and incorporating the two 18V zener diodes for voltage sensing is:

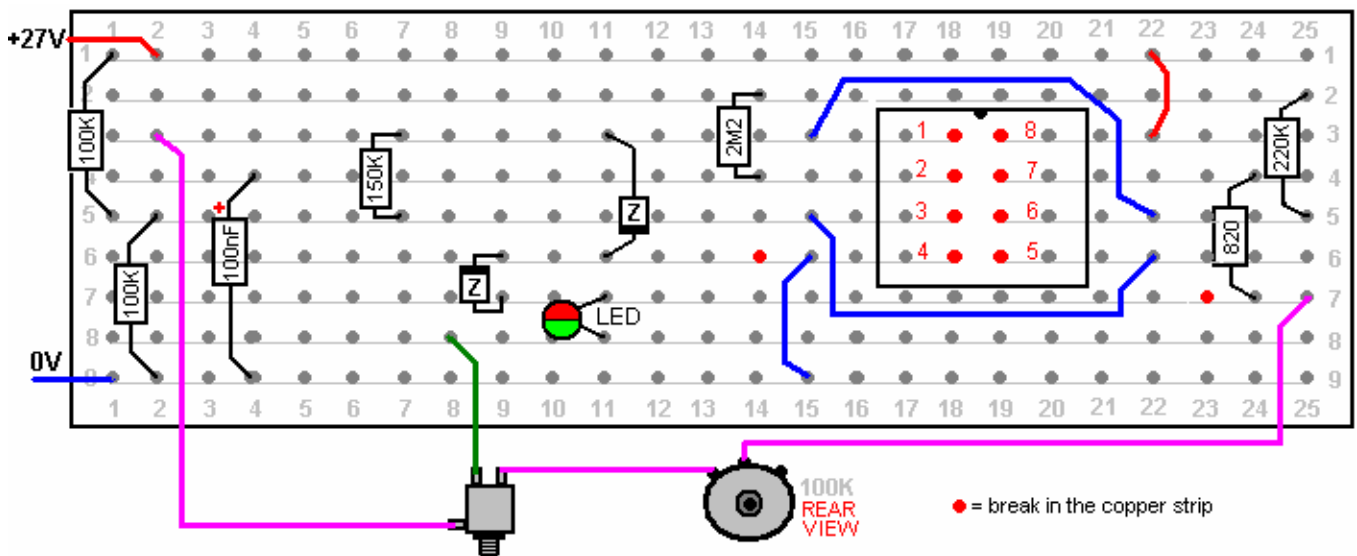

When using a Beck device, it is very important to pay attention to the precautions which Bob sets out. These are in his "Take Back Your Power" pdf document: <http://www.free-energy-info.tuks.nl/Beck.pdf> which includes the following, which, while it refers to treatment to deal with HIV, presumably applies to all treatments with his device:

EXPANDED INSTRUCTIONS FOR EXPERIMENTAL / THEORETICAL HIV BLOOD NEUTRALIZATION

HYPOTHETICAL PROTOCOLS FOR EXPERIMENTAL SESSIONS

Revision March 20, 1997. Copyright 8 1991/1997 Robert C. Beck

PRECAUTIONS: Do NOT use wrist to wrist current flow with subjects who have cardiac pacemakers. Any applied electrical signals may Interfere with 'demand' type heart pacers and cause malfunction. Single wrist locations should be acceptable. Do NOT use on pregnant women, while driving or using hazardous machinery.

Users MUST avoid Ingesting anything containing medicinal herbs, foreign or domestic, or potentially toxic medication. nicotine, alcohol, recreational drugs. laxatives, tonics. and certain vitamins etc., for one week before starting because blood electrification can cause electroporation which makes cell membranes pervious to small quantities of normally harmless-chemicals in plasma. The effect Is the same as extreme overdosing which might be lethal. See *Electroporation: a General Phenomenon for Manipulating Cells and Tissues*; J.C. Weaver, Journal of Cellular Biochemistry 51:426-435 (1993). Effects can mimic increasing dosages many fold. Both the magnetic pulsar and blood purifier cause electroporation.

Do NOT place electrode pads over skin lesions, abrasions, new scars, cuts, eruptions, or sunburn. Do NOT advance output amplitude to uncomfortable levels. All subjects will vary. Do NOT fall asleep while using. The magnetic pulsar should be safe to use anywhere on body or head.

Avoid ingesting alcohol 24 hours before using. Drink an 8 oz. glass of distilled water 15 minutes before and immediately following each session end drink at least four additional glasses daily for flushing during 'neutralization' and for one week thereafter. This Is imperative. Ignoring this can cause systemic damage from unflushed toxic wastes. When absolutely essential drugs *must* be ingested, do so a few minutes *after* electrification then wait 24 hours before next session.

If subject feels sluggish, faint, dizzy, headachy, light-headed or giddy, nauseous. bloated or has flu-like symptoms or rashes after exposures, reduce pulsing per session and/or shorten applications of electrification. Drink more water-preferably ozonized -to speed waste oxidation and disposal. Use extreme caution when treating patients with impaired kidney or liver function. Start slowly at first like about 20 minutes per day to reduce detoxification problems.

To avoid shock liability, use batteries only. Do NOT use any line-connected power supply, transformer, charger, battery eliminator, etc. with blood clearing device. However line supplies are OK with well-insulated magnetic pulse generators (strobe lights).

Health professionals: Avoid nicotine addicts, vegans, and other unconsciously motivated death-wishers and their covert agendas of 'defeat the healer'. Tobacco, the most addictive (42times more addictive than heroin) and deadly substance of abuse known, disrupts normal cardiovascular function. True vegetarian diets are missing essential amino acids absolutely necessary for the successful rebuilding of AIDS-ravaged tissues. Secondary gains (sympathy / martyrdom, work avoidance, free benefits, financial assistance, etc.) play large roles with many AIDS patients. "Recovery guilt" as friends are dying has even precipitated suicide attempts masked as 'accidents'. Avoid such entanglements, since many have unconscious death wishes.

SUPERIOR ELECTRODES: Excellent, convenient and vastly superior electrodes, reusable indefinitely can be made by butt-soldering lead wires to ends of 1" long by 3/32" dia. blanks cut from type 316 stainless steel rods available from welding supply stores (Cameron Welding Supply, 11061 Dale Ave., Stanton, CA 90680). Use 'Stay Clean' flux before soldering (zinc chloride/hydrochloric acid). Shrink-insulate TWO tight layers of tubing over soldered joints to prevent flexing/breaking and lead/copper ions from migrating. Wrap three or four turns of 100% cotton flannel around rods. Spiral-wrap with strong thread starting from wire side to end, tightly pinch cloth over the rod's end so as to leave no metal exposed by wrapping 6 or 7 turns of thread TIGHTLY just off end of rod, then spiral wrap back to start and tie tightly with four knots then cut off excess cloth at end close to pinch -wraps. Treat end windings and knots with clear fingernail polish or Fray Check®(fabric & sewing supply stores) to prevent ravelling. Soak in a strong solution of sea salt (not table salt) containing a little wetting agent like Kodak Photo Flow, ethylene glycol, or 409 kitchen cleaner. Add a few drops of household bleach, sliver colloid, etc., for disinfectant. Store solution for reuse. Tape soaking-wet electrodes tightly over pulse sites with paper masking or Transpore™ tape or with 1"wide stretch elastic bands with tabs of Velcro ® at ends to fasten. Electrodes should closely conform *precisely* along blood vessels, not skewing ever so slightly over adjacent flesh. This insures better electrical conductivity paths to circulating blood and insures very low internal impedance. (~2000W). Rinse and blot-dry electrodes and skin after each use. NEVER allow bare metal to touch skin as this will cause burns manifested as small red craters that heal slowly. The objective is to get maximum current into blood vessels, not leak it over to adjacent tissue. Therefore never use any electrode wider than about 1/8 inch (3 mm).

ELECTRODE PLACEMENTS: Locate *maximum* pulse position (*NOT* to be confused with acupuncture, reflexology, Chapman, etc. points) on feet or wrists by feeling for maximum pulse on inside of ankle ~1"below and to rear of ankle bone, then test along top centre of instep. Place electrode on whichever pulse site on that foot that feels strongest. Scrub skin over chosen sites with mild soap and water or alcohol swab. Wipe dry. Position the electrodes lengthwise along each left and right wrists blood vessel. Note: with subjects having perfectly healthy hearts and not wearing pacers, it is convenient to use left wrist to right wrist exactly over ulnar arterial pulse paths instead of on feet. Recent (Dec. 1995) research suggests that placing both electrodes over different arteries on the same wrist works very well (see pg. 7), avoids any current through heart, and is much more convenient and just as effective. An 8" long, 1" wide elastic stretch-band with two 1.5" lengths of 3/4" wide Velcro ® sewn to ends of opposite sides makes an excellent wrist band for holding electrodes snugly in place. With electrode cable unplugged, turn switch ON and advance amplitude control to *maximum*. Push momentary SW. 2 'Test' switch and see that the red and green light emitting diodes flash alternately. This verifies that polarity is reversing about 4 times per second (frequency is *NOT* critical) and that batteries are still good. When LED's don't light replace all three 9V batteries. Zener diodes will extinguish the LEDs when the three 9V battery's initial 27V drops below 18V after extended use. Never use any electrode larger than 1.125" (28 mm) long by 1/8" wide to avoid wasting current through surrounding tissue. Confine exactly over blood vessels only. Apply drops of salt water to each electrode's cotton cover ~every 20 minutes to combat evaporation and insure optimum current flow. Later devices are solid-state, use only three batteries and no relays, and are much smaller.

Now rotate amplitude control to *minimum* (counter-clockwise) and plug In electrode cable. Subject now advances dial slowly until he feels a "thumping" and tingling. Turn as high as tolerable but don't advance amplitude to where it is ever uncomfortable. Adjust voltage periodically as he adapts or acclimates to current level after several minutes. If subject perspires, skin resistance may decrease because of moisture, so setting to a lower voltage for comfort is indicated. Otherwise it is normal to feel progressively less sensation with time. You may notice little or no sensation at full amplitude immediately, but feeling will begin building up to maximum after several minutes at which time amplitude must be decreased. Typical adapted electrode-to-electrode impedance is on the order of 2000W. Typical comfortable input (to skin) is ~3mA, and maximum tolerable input (full amplitude) is ~7mA but this 'reserve' margin although harmless is unnecessary and can be uncomfortable. Current flowing through blood is very much lower than this *external* input because of series resistance through skin, tissue and blood vessel walls, but 50 to 100 µA through blood is essential.

Apply blood neutralizer for about 2 hours daily for ~2 months. Use judgment here. The limiting factor is detoxification. Carefully monitor subject's reactions (discomfort, catarrh, skin eruptions, weeping exudites, rashes,

boils, carbuncles, coated tongue, etc.). With very heavy infections, go slower so as not to overload body's toxic disposal capability. With circulation-impaired diabetics, etc., you may wish to *extend* session times. Again, **have subject drink lots of water**. Recent changes in theoretical protocol being currently tested suggest following up the three weeks of treatments with a 24 hours per day (around the clock) continuous electrification of blood for two days to deal a knockout blow to the remaining HIV's 1.2 day life cycle. (A. Perelson; Los Alamos Biophysics Group, Mar. 16, 1996 "Science" Journal.) Remember to remoisten electrodes regularly. If you absolutely **must** ingest prescription drugs, do so immediately **after** turning off instrument and allow 24 hours before next treatment to let concentrations in blood plasma decay to lower levels.

Remember, if subjects ever feel sleepy, sluggish, listless, nauseous, faint, bloated, or headachy, or have flu-like reactions they may be neglecting sufficient water intake for flushing toxins. We interpret this as detoxification plus endorphin release due to electrification. Let them rest and stabilize for about 45 minutes before driving if indicated. If this detoxing becomes oppressive, treat every *second* day. Treating at least 21 times should 'fractionate' both juvenile and maturing HIV to overlap maximum neutralization sensitivity windows and interrupt 'budding' occurring during HIV cells' development cycles. Treatments are claimed to safely neutralize many other viruses, fungi, bacteria, parasites, and microbes in blood. See patents US 5,091,152 US 5,139,684 US 5,188,738 US 5,328,451 and others as well as numerous valid medical studies which are presently little known or suppressed. Also, ingesting a few oz. of about 5 parts per million of silver colloid solution daily can give subjects a 'second intact immune system' and minimise or eliminate opportunistic infections during recovery phase. This miracle substance is pre-1938 technology, and unlike ozone is considered immune from FDA harassment. Silver colloid can *easily* be made at home electrolytically in minutes and in any desired quantities and parts per million strength for under 14 cents per gallon plus cost of water. It is ridiculous to purchase it for high prices. Colloid has no side effects, and is known to rapidly eliminate or prevent hundreds of diseases. Silver colloids won't produce drug resistant strains as will all other known antibiotics. No reasonable amount can overdose or injure users either topically, by ingestion, or medical professional injection.

The 741 Operational Amplifier.

An important and very useful group of Integrated Circuits is the "Operational Amplifier" or "op-amp" group. These devices have a very high gain, an 'inverting' input and a 'non-inverting' input. There are many op-amps but we will look at just one popular type called the "741" which has an 'open-loop' gain of 100,000 times. All operational amplifiers work in the same way in theory. The way they operate in a circuit is controlled by the external components attached to them. They can operate as inverting amplifier, a non-inverting amplifier (i.e. a 'buffer'), a comparator, an astable multivibrator, and various other things. The symbol and connections for a 741 op-amp are:

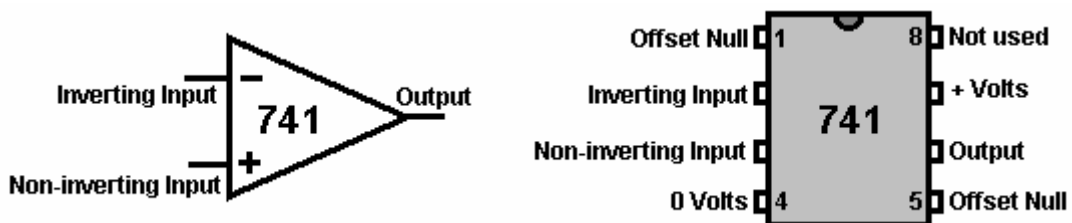

We can connect the 741 chip to act as an amplifier with any set gain level that we choose:

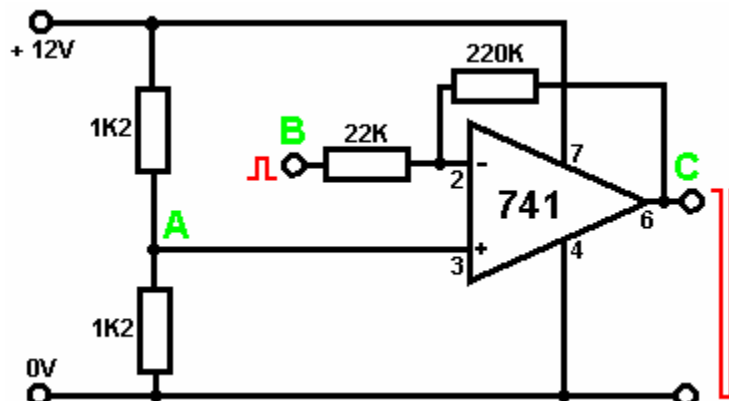

Here, the gain is set by the ratio of the 220K resistor to the 22K resistor. This circuit has a gain of 10 times, so the input signal at point 'B' will generate an output signal at point 'C' which is ten times larger, **provided** that the output signal does not approach the battery voltage. If it does, then clipping will occur with the top and the bottom of the output waveform chopped off at about a volt away from the battery voltage levels, approximately 1 Volt and +11 Volts in this example.

Operational amplifiers are generally designed to operate from a dual power supply. In the above example, the supply would be created by using two 6 Volts batteries instead of one 12 Volt battery. To avoid the inconvenience of this, a mid-point voltage is generated at point 'A' by using two equal resistors in series across the battery. This gives a central voltage of +6 Volts which is fed to the IC.

This circuit can be used in many applications. Here is a circuit for a meter to measure sound intensity:

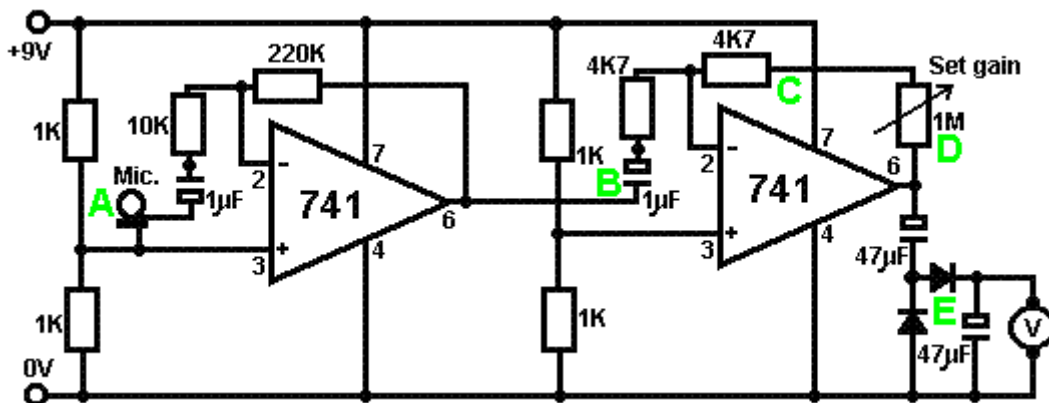

This circuit is two copies of the previous circuit. Each 741 chip has a reference voltage of half the supply voltage created by a voltage-divider pair of 1K resistors. This voltage is fed to pin 3 of the chip, which is the non-inverting input.

At point 'A', a microphone or small loudspeaker is used to generate a signal voltage when sound reaches it. This voltage is fed to the 741 op-amp via a 1 microfarad blocking capacitor. This passes the audio signal through while blocking the +4.5 Volts DC on pin 3. The first 741 has a gain of 22, set by the 10K and 220K resistors ($220/10 = 22$).

Point 'B' then receives an audio signal 22 times larger than the signal produced by the microphone. This signal is still quite small, so the second 741 boosts it further. The gain of the second 741 is variable and depends on the resistance set on the 1M variable resistor. If the variable resistor is set to zero ohms, then the gain of the second 741 will be controlled by the 4K7 resistor at point 'C' alone and so will be 1 ($4.7/4.7 = 1$). If the variable resistor is set to its maximum value, then the gain of the second 741 will be some 214 ($1,004,700/4,700 = 213.8$).

The two op-amps together have a combined gain which ranges from 22 to 4702. The amplified audio signal arrives at point 'D' and it can be adjusted to a respectable value. This alternating voltage is now rectified via the diodes at point 'E' and it builds up a DC voltage across the 47 microfarad capacitor there. This voltage is displayed on a voltmeter. The result is that the voltmeter shows a reading directly proportional to the sound level reaching the microphone.

The 741 can be wired as a **buffer**. This is the equivalent of an emitter-follower circuit when using transistors. The set up for the 741 is:

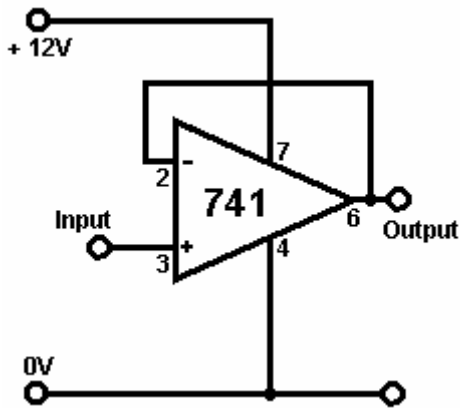

Difficult circuit - huh! Are you sure you can afford all the extra components? This circuit utilises the full gain of the 741 chip. The output follows the input waveform exactly. The input requires almost no current, so the circuit is described as having a 'high input impedance'. The output can drive a serious load such as a relay, so the circuit is described as having a 'low output impedance'.

The 741 chip can be wired to act as a comparator. This is the circuit:

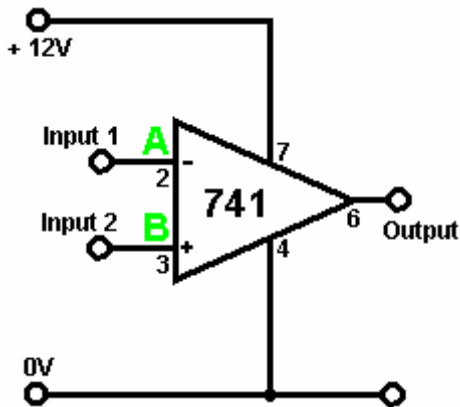

Are you sure you are up to such a difficult circuit? Bit complicated - huh! This is the basic operational form for an operational amplifier.

If the voltage at point 'A' is higher than the voltage at point 'B' then the output goes as low as it can go, say 1 or 2 volts.

If the voltage at point 'A' is lower than the voltage at point 'B' then the output goes as high as it can go, say 10 volts or so.

Having seen how transistor circuits work, you should be able to understand why the 741 chip circuitry (which is a transistor circuit inside the 741 package) needs some voltage inside the supply rails to provide an efficient high-current output drive.

Here is a 741 version of the light-operated switch:

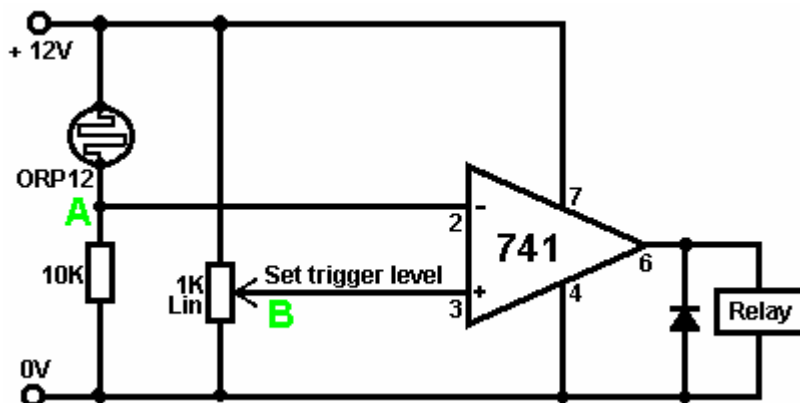

This circuit is set up as evening falls. We want the relay to have minimum voltage across it in daylight, so the voltage at point 'A' needs to be higher than the voltage at point 'B'. As the 1K variable resistor is across the supply voltage, its slider can be set to any voltage between 0 Volts and +12 Volts. To make this easy to do, we choose a 'linear' variable resistor as the logarithmic variety would be hard to adjust in this application. With the 'linear' version, each 1 degree of rotation of the resistor shaft causes the same change in resistance, anywhere along the range. This is not the case for the logarithmic variety.

Anyhow, we adjust the variable resistor downwards until the relay voltage drops to a minimum. When the light level has fallen to the level at which we wish the circuit to trigger, we adjust the variable resistor to make the relay click on. The 741 chip has a very rapid output voltage swing when the input voltages swap over, so the relay switching will be decisive. The switching can be made even more positive by adding a resistor between the output and point 'B'. This acts like a Schmitt trigger when switching occurs by providing some additional positive feedback, lifting the voltage at point 'B'.

If you wish the circuit to trigger on a rising light level, just swap the positions of the 10K resistor and the ORP12 light-dependent resistor. The same circuit will operate as a temperature sensing circuit by substituting a 'thermistor' (which is a temperature-dependent resistor) for the ORP12.

If we would like the circuit to act as a burglar alarm, we could use the same circuit like this:

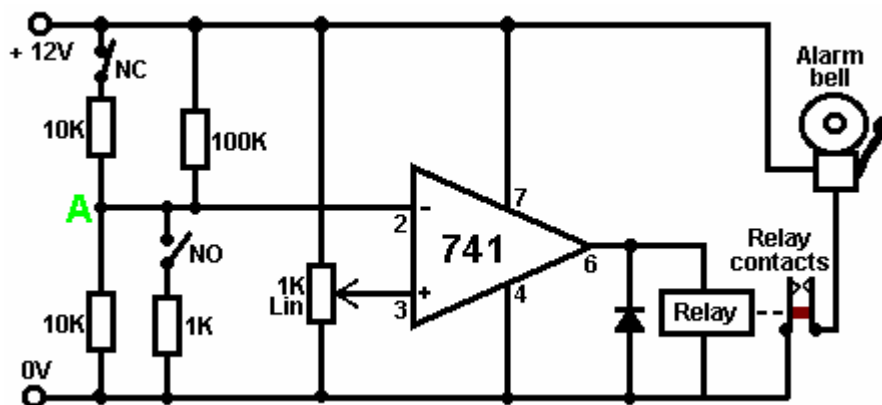

The circuit is still controlled by the voltage at point 'A'. Under normal circumstances, this voltage will be near +6 Volts (produced by the two 10K resistors and the 100K resistor). The upper switch marked 'NC' for 'Normally Closed', represents a chain of, say, magnetic switches attached to doors and windows. If any of these are opened, then the voltage at point 'A' will be dictated by the lower 10K resistor in series with the 100K resistor. This will cause the voltage at 'A' to fall instantly to a low value, triggering the circuit.

The 'NO' switch ('Normally Open') represents one or more pressure-operated switches under carpets or rugs and/or switches which get brushed when doors are swung open, etc. These switches are wired in parallel across each other and if any of them is closed for even a millionth of a second, the voltage at point 'A' will be pulled down by the 1K resistor and the circuit will be triggered.

The circuit can be latched on in any one of a variety of ways. One relay contact can be used to hold the relay on or hold the voltage at 'A' low. A transistor can be wired across the relay to hold the circuit on, etc. etc. If this is done, the circuit will remain in its triggered state until the supply voltage is interrupted. You might prefer to use a 555 chip to limit the length of time the alarm sounds to three minutes or so.

The SCR and Triac.

An alternative to using a relay or semiconductor latch is to use a **Silicon Controlled Rectifier** usually referred to as an 'SCR' or 'Thyristor'. This device is normally "off" with a very high resistance to current flow. If it is switched on by applying a voltage to its Gate connection, it stays continuously on until some external device stops current flowing through it. The following circuit shows how it operates:

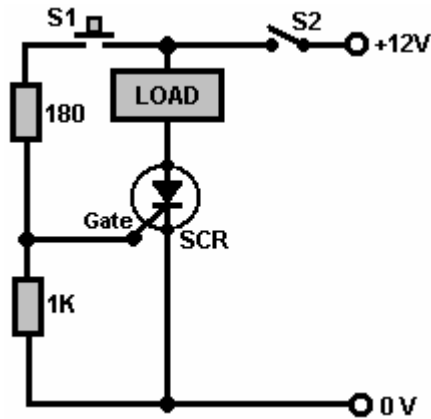

When the voltage is first applied to the circuit by closing switch S2, the SCR is in its OFF state so no current is supplied to the load. If the press-button switch S1 is pressed, a current is fed into the Gate of the SCR, turning it ON. When switch S1 is allowed to open, the SCR remains in its ON state and it will stay that way until the current through it is cut off. Opening switch S2 cuts off the current to the load and the SCR returns to its OFF state. A very valid question would be: "Why have an SCR at all and just turn the load on and off with switch S2?". The answer is that switch S1 might be the under-carpet pressure pad of a burglar-alarm and it might be operated some hours after switch S2 was closed to activate the alarm system. Stepping off the pressure pad does not stop the alarm sounding.

While this sort of DC latching action is useful, it is more common for an SCR to be used in an AC circuit. For example, take the circuit shown here:

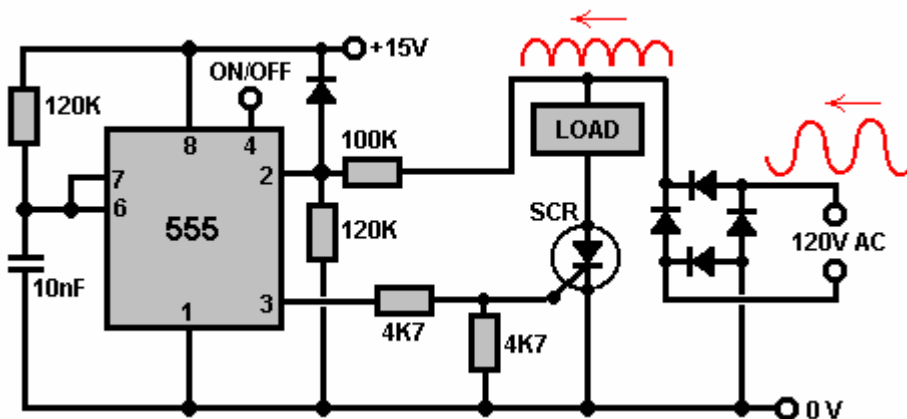

The 120 volt AC supply coming in from the right hand side, is converted to positive-going sine-wave pulses by the diode bridge. This pulsing voltage is applied to the Load/SCR path. If the voltage at pin 3 of the 555 chip is low, then the SCR will remain OFF and no current will be fed to the load device. If the voltage on pin 3 goes high **and** the voltage applied to the Load/SCR chain is high, then the SCR will be switched ON, powering the load until the pulsing voltage drops to its zero level again some 1/120 of a second later.

The 555 chip is connected to form a monostable multivibrator and the timing components (the 120K resistor and the 10nF capacitor) cause it to output a 1 millisecond pulse which is long enough to trigger the SCR into its ON state, but short enough to have finished before the mains pulse reaches its zero-voltage level again. The 555 chip is triggered by the rising mains voltage being passed to its pin 2 through the voltage-divider 100K and 120K pair of resistors, and that synchronises it with the AC waveform. Pin 4 of the 555 chip can be used to switch the load power on and off.

In the circuit shown above, the diode bridge is needed to convert the incoming AC waveform to pulsing DC as shown in red in the diagram, as the SCR can only handle current flowing in one direction. The AC load equipment works just as well with the pulsing DC as with a full blown AC waveform. A better semiconductor construction is the 'Triac' which acts like two SCR devices back-to-back in a single package. It is shown like this in circuit diagrams:

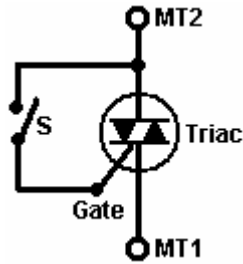

There are three connections to the device: Main Terminal 1, Main Terminal 2 and the Gate. When switch 'S' shown in the diagram is closed, the triac conducts on both positive and negative voltages applied to its MT1 and MT2 terminals. When the switch is open, the device does not conduct at all.

If the external circuit containing switch 'S' is placed inside the device as a permanently closed circuit, then the device becomes a 'Diac' which can be used to trigger a Triac and give a very neat circuit for controlling the power to an item of AC mains equipment as shown here:

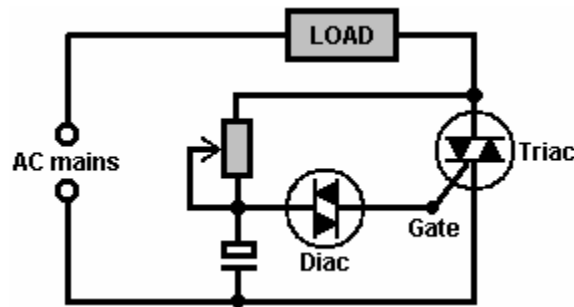

Here, the variable resistor/capacitor pair controls the point on the AC waveform that the Triac is triggered and so controls how much of each sinewave cycle is passed to the mains equipment, and so it controls the average power passed to the equipment. A very common use for a circuit of this type is the 'dimmer-switch' used with household lighting.

To return now to the 741 chip. The 741 can also be used as an **astable multivibrator**. The circuit is:

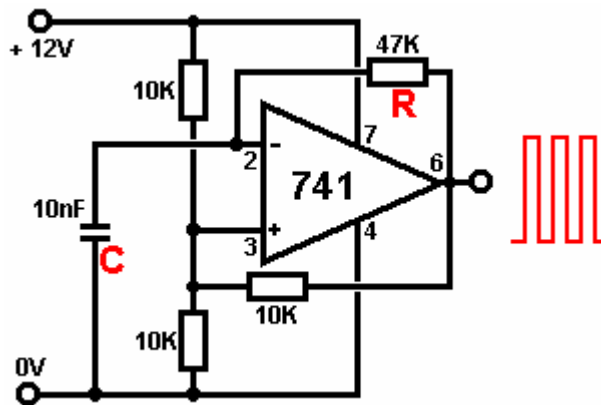

The rate of oscillation of this circuit is governed by the Resistor marked 'R' in the diagram and the capacitor marked 'C'. The larger the resistor, the lower the rate of oscillation, the larger the capacitor, the lower the rate of oscillation.

When the output goes high, capacitor 'C' charges up until the voltage on it exceeds the mid-rail voltage on pin 3, at which time the 741 output goes low. The capacitor now discharges through resistor 'R' until the voltage on it drops below the voltage on pin 3, at which time the output goes high again. The 10K resistor connecting the output to pin 3 provides some positive feedback which makes the 741 act quite like a Schmitt trigger, sharpening up the switching.

The same arrangement of resistor and capacitor applied to a Schmitt inverter or Schmitt NAND gate causes exactly the same oscillation:

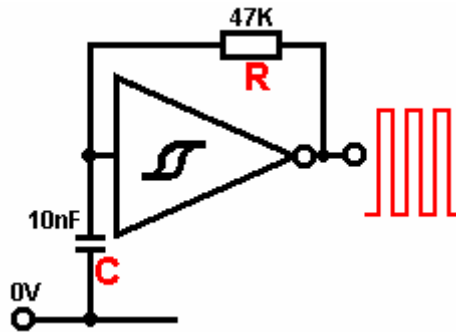

If you would like to see additional ways of using 741 and 555 chips, I can recommend the excellent book "Elementary Electronics" by Mel Sladdin and Alan Johnson ISBN 0 340 51373 X.

A Hex Inverter Signal Generator.

Here is a very well tested and highly thought of, low-cost oscillator circuit, using a 74HC14 Schmitt inverter chip. It allows fine tuning control of the frequency and the pulse width produced. Three of the inverters are connected together to give a more powerful output current drive:

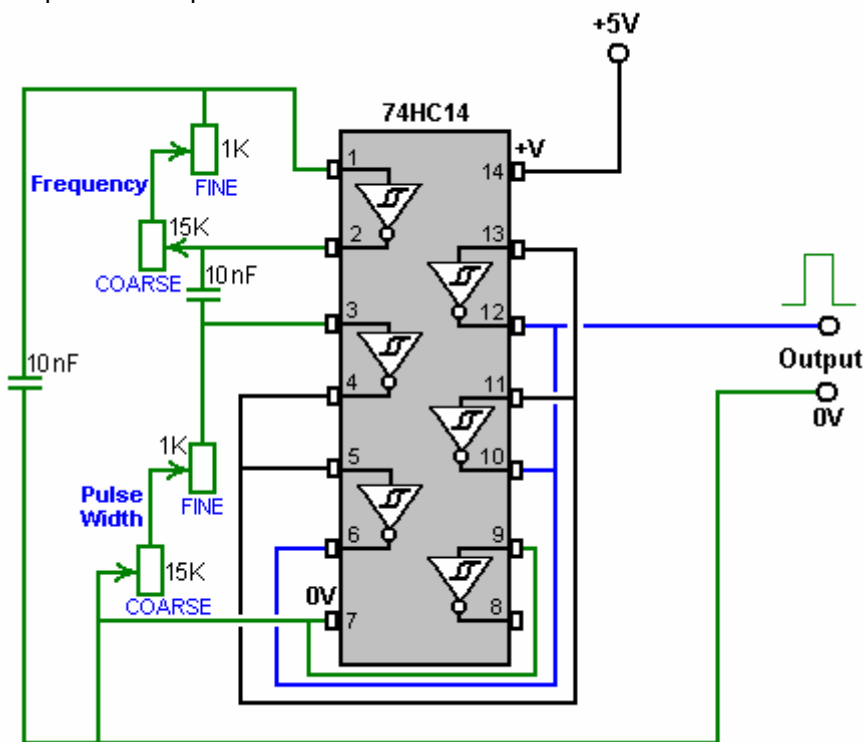

The 4022 Divide-by-Eight Chip.

One very useful CMOS integrated circuit is the '4022' chip which is a 16-pin 'divide by 8' chip with built-in decoding. The connections are:

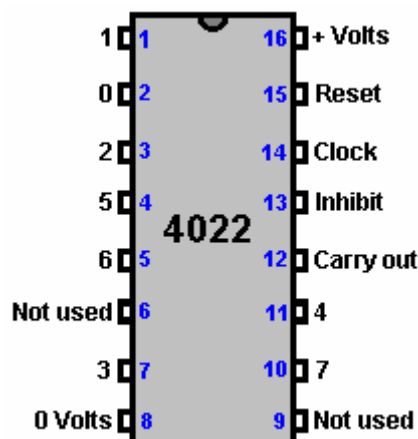

If pin 14 is provided with the output from some variety of astable multivibrator, on the first pulse, this chip sets the "0" output on pin 2 to High while the other outputs are Low. On the next pulse, the "0" output goes Low and the "1" output on pin 1 goes High. On the next pulse, output "1" goes Low and the "2" output on pin 3, goes High. And so on until on the eighth pulse, output "7" on pin 10 goes Low and output "0" goes high again.

The chip can also divide by lower numbers:

For 'Divide by 7' operation, connect pin 10 to pin 15 (this resets the output to '0')

For 'Divide by 6' operation, connect pin 5 to pin 15

For 'Divide by 5' operation, connect pin 4 to pin 15

For 'Divide by 4' operation, connect pin 11 to pin 15

For 'Divide by 3' operation, connect pin 7 to pin 15

For 'Divide by 2' operation, connect pin 3 to pin 15

If you want a 'Divide by 1' circuit, I suggest you cut down on the amount of alcohol you drink.

Here is an illustration of a 'Divide by 4' setup:

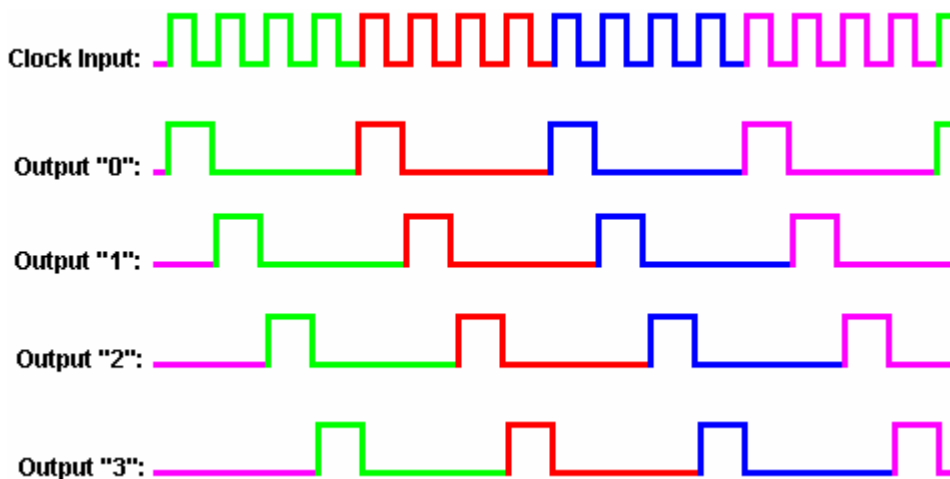
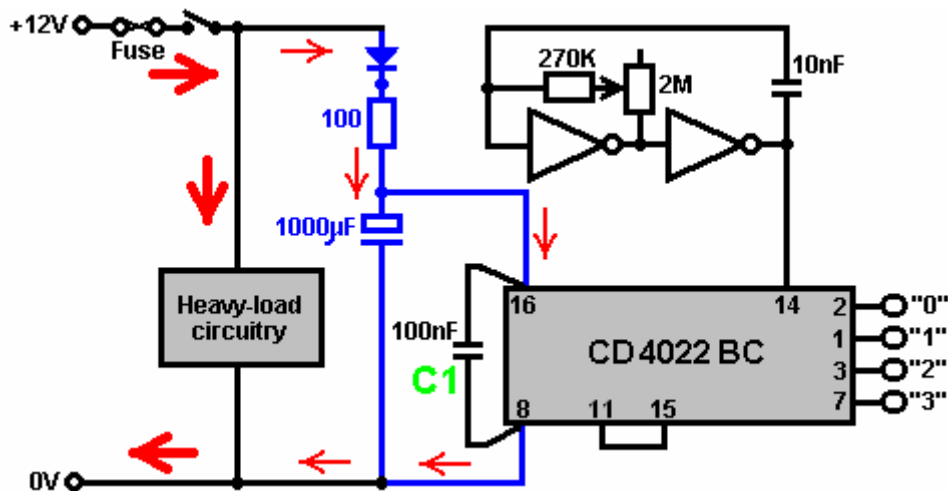

There are a number of things to notice in the above diagram. Firstly, the practical arrangements for circuitry have not been stressed before. If the circuitry has a pulsing circuit drawing heavy current, as shown by the thick red arrows, then it should be physically connected to the battery and any low-current circuitry should be further away from the battery. The supply from the battery should have a fuse or circuit breaker and a switch in the line before anything else is connected, so that if any component develops a fault and goes short-circuit, the fuse will blow and prevent any significant problems.

Secondly, it is a good idea to provide the other circuitry with a smoothed power supply as shown by the blue components in the diagram. This minimises the effect if the battery voltage gets pulled down by the pulsing of the

high-current circuitry. The diode (silicon, 1 Amp, 50 V) stops the heavy current circuit drawing current from the large smoothing capacitor. The 100 ohm resistor limits the current into the large capacitor on switch-on and provides a little more smoothing. This circuitry is called “de-coupling” as it de-couples the low current circuitry from the high current circuitry.

Thirdly, notice capacitor “C1” which is wired physically as close to the power supply pins of the integrated circuit as is possible. If a spike is superimposed on the battery supply, then this capacitor soaks it up and prevents it damaging or triggering the integrated circuit. A spike could be caused by a very strong magnetic pulse nearby as that can induce an extra voltage in the battery wires.

The lower part of the diagram shows the output voltages produced as the clock pulses reach pin 14 of the chip. The positive-going part of the clock signal triggers the change in state of the outputs. If necessary, a positive-going pulse on the reset pin, pin 15, causes output “0” to go high and the other outputs to go low.

The 4017 Divide-by-Ten Chip.

Now, to take this output sequencing a little further. For example, the Charles Flynn magnet motor shown in Chapter 1 needs coils to be powered up, one after the other and only one should be on at any one time. This calls for a circuit which has a large number of outputs. The CD4022BC chip gives up to eight outputs one after the other. The CD4017B chip gives up to ten outputs one after the other but there is no need to be limited by these numbers as more than one chip can be used. If you find this section difficult to understand, then just skip past to the next section as it is not important for you to understand these larger circuits.

The pin connections for the divide-by-ten CD4017B chip is shown here:

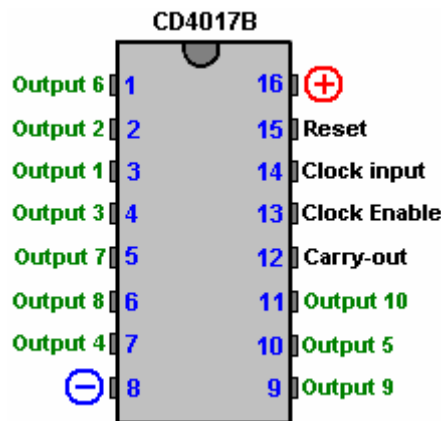

While this shows outputs 1 to 10, the manufacturers and some people who draw circuits, prefer to label the outputs as “0 to 9” which correspond to digital displays. In our style of operation, it is easier to think of the ten outputs as being from 1 to 10.

You will notice that there are two pin labels which we have not come across before, namely, the “Carry-out” pin and the “Clock Enable” pin. These allow us to use several of these chips in a row to give a much larger “divide-by” number. The “Clock Enable” pin can be used to block the clock input. The operation is like this:

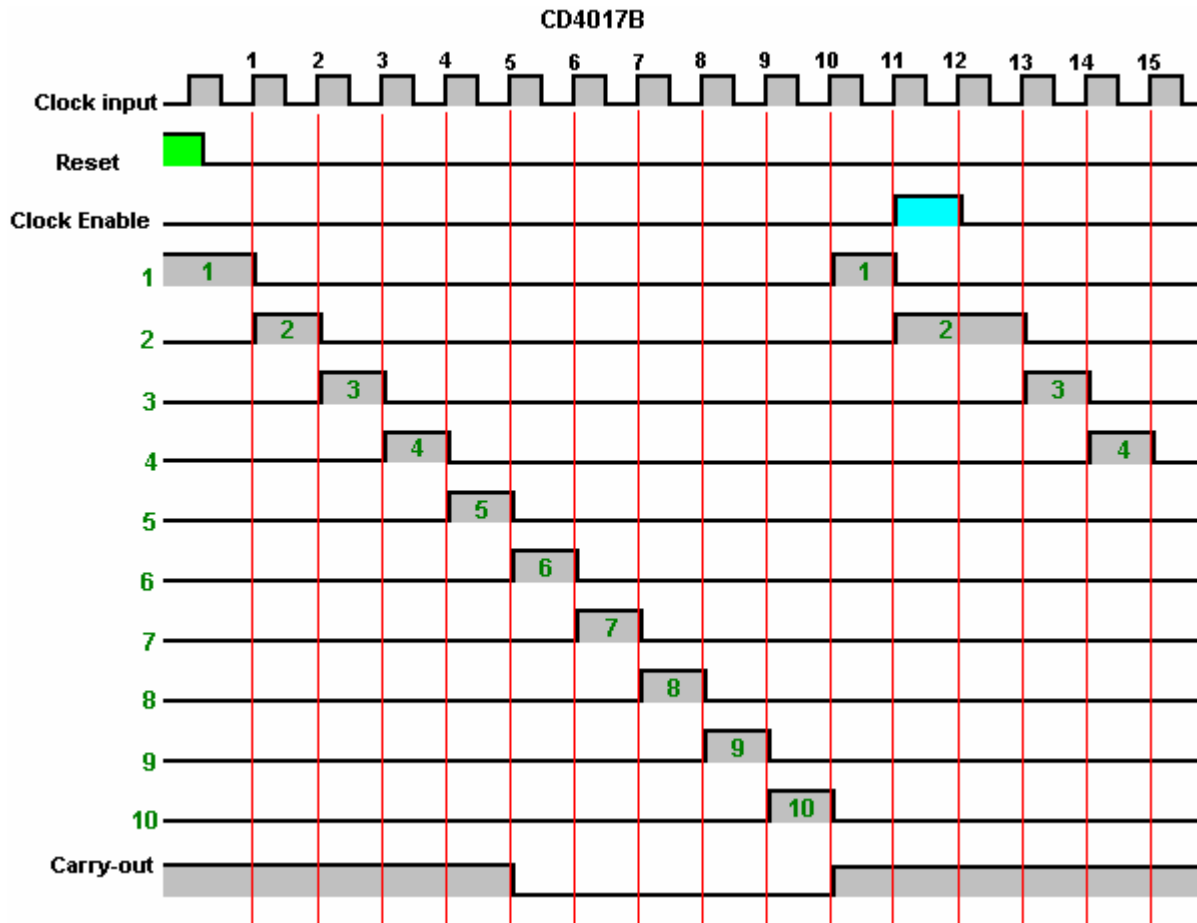

In this example, the sequence is started by the Reset pin being given a high voltage as shown by the green shading. This pushes the output pin 1 to a high voltage and all of the other outputs to a low voltage and holds those voltages as long as the reset voltage is high.

When the Reset voltage drops, the next rising edge of the clock pulse (marked "1" in the diagram) causes the output 1 to go low and output 2 to go high. Each of the successive clock pulses "2" to "9" moves the high voltage steadily along the outputs until output pin 10 is high.

The next clock pulse rising edge (marked "10" in the diagram) starts the sequence again with output 10 going low and output 1 going high again. If nothing changes, then that sequence of output voltage changes will continue indefinitely.

However, in the diagram above, the Clock Enable pin voltage is driven high on clock pulse "11". Output 2 has just gone high and would have gone low when the rising edge of clock pulse "12" occurred, but in this case, the Clock Enable feature blocks the clock pulse and prevents it reaching the rest of the circuitry. This causes the output 2 voltage to stay high as long as the Clock Enable remains high. In this example, the Clock Enable voltage stays high for just one clock pulse, causing the output 2 voltage to be high for twice its usual length, and then the sequence continues as before.

A Divide-by-Twenty-five Circuit.

Here is one way to get a large "divide-by" number. This example is divide-by-25 because there is only one 'intermediate stage' but there can be any number and each additional one adds another eight outputs to the total:

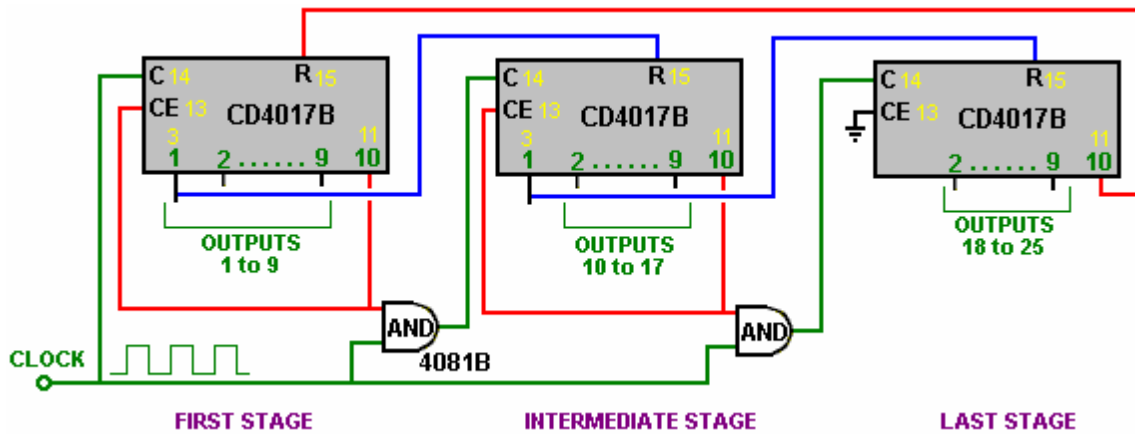

At startup, output 10 of the first stage (which is physical pin 11 of the chip) is at a low voltage. This holds the Clock Enable (pin 13) low, allowing the clock pulses to enter the first stage. Because the output 10 voltage is low, one input to the first AND gate is held low, preventing it from letting the clock pulse flow through it, i.e. the "gate" is closed to through traffic.

The first stage chip then operates as normal, producing outputs 1 to 9 in order as you would expect. The next clock pulse steps the first stage output 10 high, allowing the clock pulses through the first AND gate and holding the Clock Enable (pin 13) high, which in turn locks the output 10 high, dropping the first stage chip out of the operation.

As the output 1 of the first stage is connected to the Reset (pin 15) of the second chip, it will have been cleared and its output 1 set high, which in turn Resets the third chip and closes the second AND gate. So, when the first pulse gets through to the second chip, it pushes it from state 1 to state 2 where the output 2 goes high. For that reason, output 1 of the second chip is not one of the outputs which can be used by whatever following circuitry you choose to connect to this system. Consequently, only eight of the ten outputs of the second chip are available as counter outputs. That is, outputs 1 and 10 are taken up in passing the switching sequence between the various chips in the chain.

The same applies to all following chips in the chain, each extra chip adding up to eight extra sequential outputs. On the final stage chip, if you connect the red Reset wire (which goes back to fire up the first chip again) to output 9 instead of output 10 of the final chip, then you get a divide-by-24 result.

If the Reset is taken from output 8 of the final chip, then you get a divide-by-23 result, and so on. Using this method, you can have a divide-by circuit for any number you want. These chips are very popular and so their cost is low, making the entire circuit cheap to make. The pin connections for the AND gates is shown here:

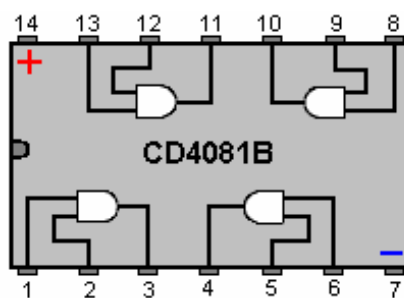

The PIC Revolution.

Over the years, there have been advances in the way that circuitry can be put together, prototypes built and tested. Initially, "valves" or "vacuum tubes" were used and circuits required a good deal of electrical power in order to operate. Mechanical vibrators or "reeds" were used to generate the switching needed to convert DC into AC. Then the transistor became widely available and the transistor replaced the mechanical vibrator reed, the circuit being called an "astable multivibrator" and comprising of two transistors wired back to back (as described in chapter 12). Then came the digital integrated circuit with its "NOR gates" which could also be wired back to back to make a multivibrator. This was done so often that a special integrated circuit called the "555 chip" was designed to do the job all on its own. That chip has been a tremendous success and is now found in all sorts of different circuits, being very easy to use, very robust and very cheap. Surprisingly, the dominant position of the "555" chip is being challenged by a completely different type of chip, one which is essentially, a computer on a

single chip, and which is called a "PIC controller".

This new type of chip is not expensive, is easy to use, and can be changed to perform a different task in just a few seconds. It can perform timing tasks. It can act as a multivibrator. It can act as a "Divide-by-N" chip. It is a very impressive chip which is very useful. The reason that I mention it here is because it is at the heart of the fastest working Tesla Switch research forum around (the "energetic forum" group). The chip is something you need to know about as it will certainly take over more and more circuit applications in the coming years.

There is a whole family of these processor chips, but I will select just one for this description, and that will be the one being used by the "energetic forum" members, and I have to thank Jeff Wilson for his help in describing this circuitry, the programming and the methods which he uses.

First, however, some information on this new design of chip and the methods used with it. The one used by Jeff is called the "PICAXE-18X" and it looks like the chip shown here. From which you can see, it looks just like any other chip, although with eighteen pins. The powerful performance comes from the way that it operates. You are probably familiar with the "555" chip and understand that it operates by changing the voltage on just one of its pins (pin 3) the output pin, from a low voltage to a high voltage. The PIC chip can do that as well, but even better still, it has more than one output pin and it can alter the voltage on any of those pins to either a high or a low voltage and it can do that in any order and with any timing that you choose. This makes it a very versatile chip indeed and one which is very well suited to be the central controller for a Tesla Switch test environment.

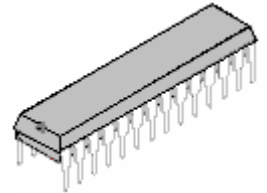

The chip is used by wiring it into a circuit in the same sort of way that a 555 chip would be used, except that the PIC has its own internal timing clock and can operate in intervals of one thousandth of a second, that is, one millisecond.

PICAXE-18X

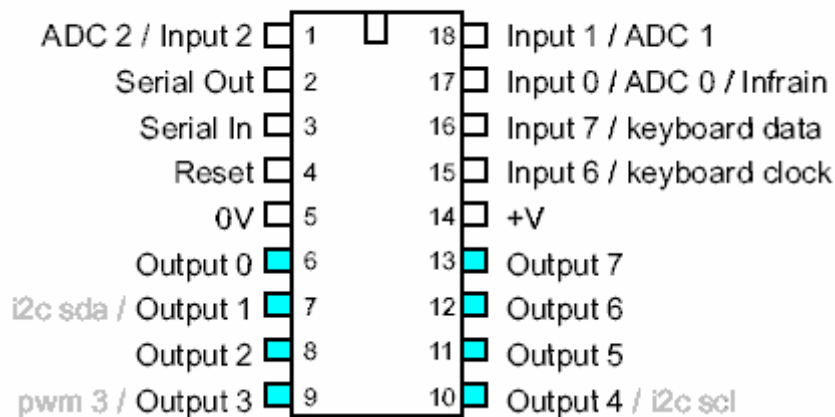

The top eight pins are for making the chip work. The next two are for providing the chip with electrical power. The bottom eight pins are separate outputs, any one of which can operate switches, timers, etc., just as the output from a 555 chip can. Having been named by computer people, instead of the eight output pins being numbered from 1 to 8 as any rational person would do, they have numbered them from 0 to 7.

The voltage on those output pins will be either High or Low. PIC switching can be used with a wide range of different free-energy designs. The PIC chip is generally supplied with a socket, a connecting cable and a program for feeding instructions into the chip. The feed is generally from an ordinary PC. The programming instructions are very simple and anyone can learn how to use them in just a few minutes.

So let's look at a circuit which has been used by Jeff when he tests prototype circuitry. The first part of the circuit is for connecting the standard PC socket to the PIC chip and it looks like this:

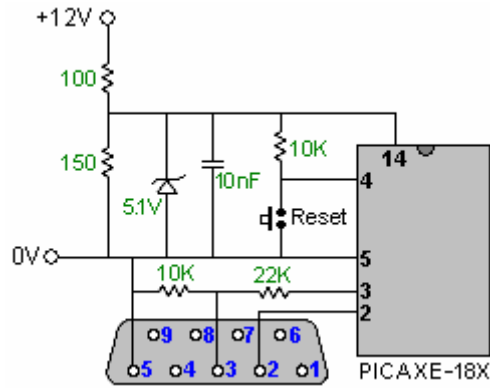

A standard 9-pin computer socket has its pin 2 connected to the PIC's pin 2, pin 3 connected to the PIC's pin 3 via a 10K / 22K voltage divider resistor pair (which lowers the incoming signal voltage), and pin 5 is connected to the PIC's pin 5. That is all that's needed to feed information into the PIC chip.

The chip is supplied from a 12-volt battery but as it needs a 5-volt supply, the 100 / 150 ohm (2 watt) resistor pair is used to drop the 12 volts down to about 7 volts and then the 5.1-volt zener diode clamps the voltage at 5.1 volts, which is just what the chip needs. The tiny 10 nF (0.01 microfarad) capacitor is there to trap any voltage spikes should any be picked up from some outside influence. Finally, the press-button switch used to short between pins 4 and 5 is used to wipe out the program inside the PIC, ready for a new program to be loaded.

The actual programming is not difficult and the feed into the chip is handled by the program supplied with the chip and which is run on your home computer. Let's take an example. Suppose we want the output on pin 10 to act as a clock signal. The people who made the chip expect that pin to be called "Output 4" in the program. Please don't ask me why it isn't called "10" in the program as I have no answer for you other than "it takes all sorts of people to make a world".

All right, suppose we want to produce an output signal like a 555 chip running at 50 Hz. We choose one of our output pins, say, the physical pin 10, that being the bottom right hand pin on the chip. As you can see from the pin diagram of the chip shown above, pin 10 is called "Output 4" in a set of commands, or just "4" to save typing. The program might be:

```
Main:
  high 4
  pause 10
  low 4
  pause 10
goto Main
```

Wow - really difficult stuff !! Only a genius could manage to program! Well, we'll see if we can struggle along with this "difficult" stuff.

The "Main:" at the start is a "label" which can be jumped to and that is done by the "goto Main" command which sends the chip back to repeat the commands in the loop indefinitely (or until the chip is powered down).

The second line "high 4" tells the chip to put the maximum possible voltage on the "Output 4" which is the physical pin 10 of the chip. The chip does this immediately, with no time delay.

If we want the output to give a 50 Hz output signal, then the voltage on our chosen output pin will have to go high, pause, go low, pause and go high again, 50 times each second. As there are 1,000 milliseconds in one second, and the chip's clock runs with 1 millisecond ticks, then we need our complete cycle of "up, pause, down, pause" to happen 50 times in those 1,000 clock ticks. That is, once every 20 ticks, so each delay will be 10 clock ticks long.

The third line "pause 10" tells the chip to sit on its hands and do nothing for the next 10 ticks of its internal clock (which ticks 1,000 times per second).

The fourth line "low 4" tells the chip to lower the output voltage on its "Output 4" (pin 10 in real life) to its minimum value.

The fifth line "pause 10" tells the chip to wait for 10 milliseconds before doing anything else.

The last line "goto Main" tells the computer to go back to the label "Main:" and continue with whatever instructions follow that label. This puts the chip into an 'infinite loop' which will make it generate that output waveform continuously. The output will look like this:

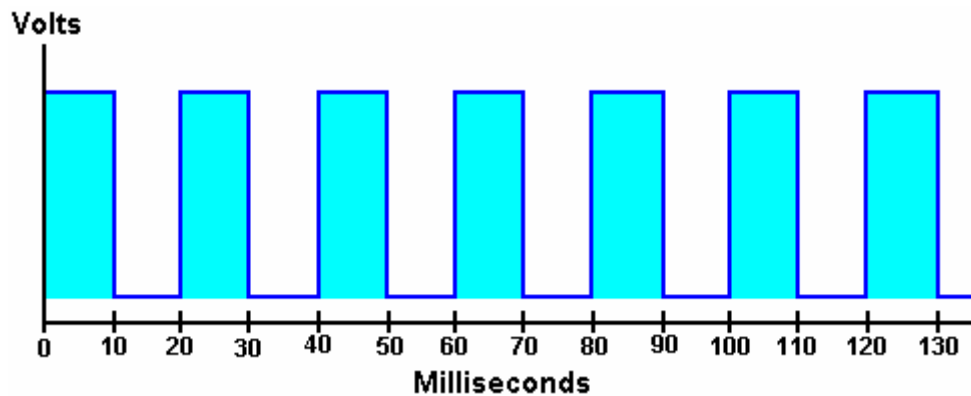

This gives an even waveform, that is, one with a Mark/Space ratio of 50:50 or a Duty Cycle of 50%. If we want the same rate of pulsing but a Duty Cycle of just 25% then the program would be:

```
Main:  
  high 4  
  pause 5  
  low 4  
  pause 15  
goto Main
```

which produces this waveform:

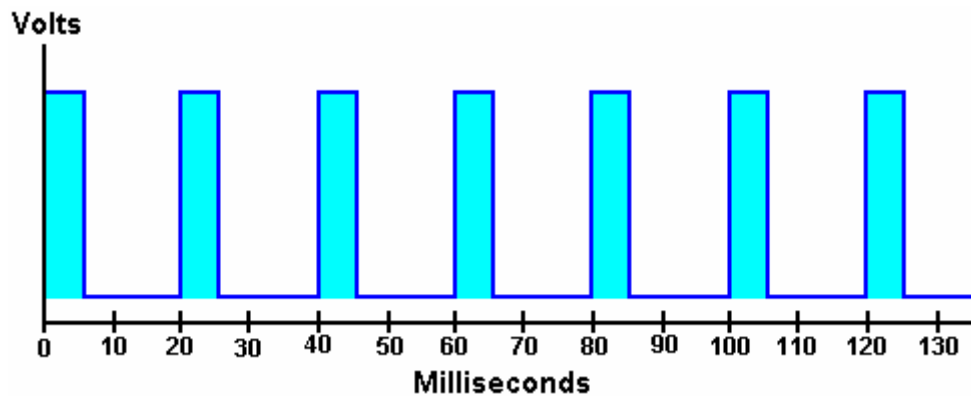

If you wanted "Output 7" (physical pin 13) to do the reverse of this at the same time - that is, when Output 4 goes high we want Output 7 to go low, and vice versa, then, for a 20% Duty Cycle the program would be:

```
Main:  
  high 4  
  low 7  
  pause 4  
  low 4  
  high 7  
  pause 16  
goto Main
```

These output voltages are then used in exactly the same way as the output voltages on pin 3 of a 555 chip, or any of the outputs of NAND gates, Hall-effect sensor chips, Schmitt triggers, or whatever. If the device to be powered requires very little current, then the easiest method is to connect the load directly to the output pin.

If, as is most often the case, the device to be powered needs a large current to make it work, then the output voltage is used to power a transistor, perhaps like this:

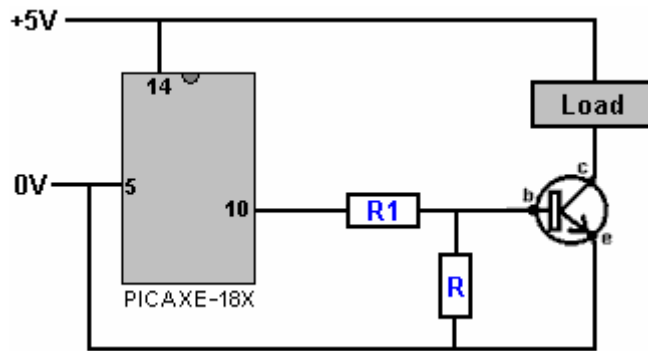

Here, the resistor "R1" limits the current fed into the base of the transistor when pin 10 goes high, but allowing enough current for the transistor to switch on fully, powering the load. The resistor "R" makes sure that the transistor switches off fully when the output on pin 10 goes low. The circuit as shown restricts the load to some piece of equipment which can operate on just five volts, so an alternative circuit could be:

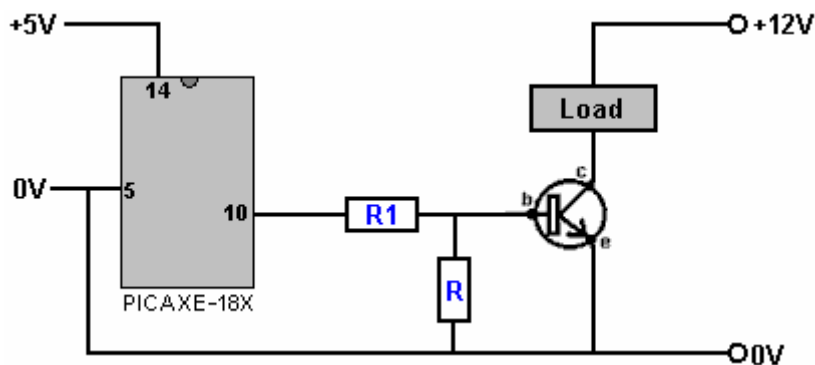

This allows whatever voltage the load needs to be applied to the load, while the PIC chip remains running on its normal 5-volt supply. However, the equipment to be powered may not be able to have a common zero voltage connection with the PIC. To deal with this, an optical isolation chip can be used like this:

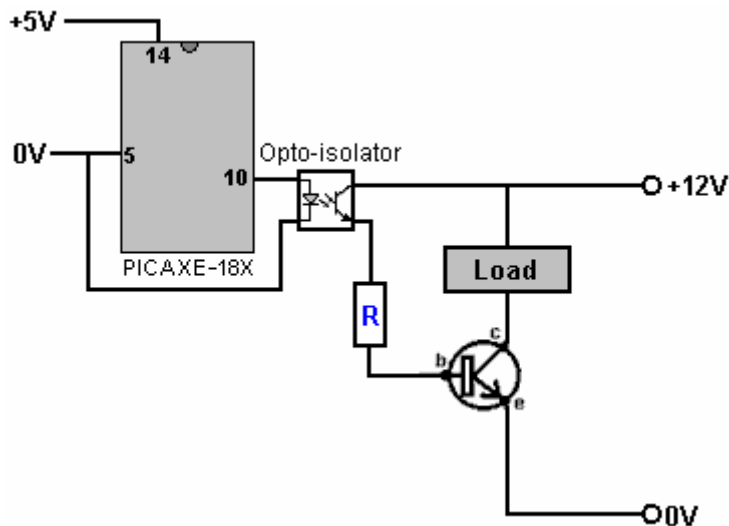

Here a high output voltage on pin 10 of the PIC chip lights up the LED inside the opto-isolator chip, causing a major drop in the resistance between the other two pins. This causes a current controlled by the resistor "R" to be fed into the base of the transistor, switching it on and powering the load.

Recently, a very popular programmable chip has been introduced. It is called the "Arduino" and it is fast and versatile and very popular with experimenters. There is an extensive set of English-language Video tutorials on the Arduino chip, the first in the series by Jeremy Blum is http://www.youtube.com/watch?v=fCzA9_kg6s. The board looks like this:



Capacitors.

We have avoided mentioning capacitors in any detail as it has not been necessary for understanding the circuitry covered so far. Capacitors come in many sizes, types and makes. Their size is stated in 'Farads' but as the Farad is a very large unit, you are unlikely to encounter a capacitor marked in anything larger than a microfarad, which is a millionth of a Farad. The symbol for a microfarad is μF where 'mu' is the letter of the Greek alphabet. This is a pain for normal text production as Greek letters do not occur in your average font. Some circuit diagrams give up on 'mu' and just write it as uF which looks like μF slightly mis-printed where the descender of the mu has not printed.

Anyway, very large capacitors which you may encounter range from 5,000 microfarads to maybe as much as 20,000 microfarads. Large capacitors range from 10 microfarads to 5000 microfarads. Medium sized capacitors run from 0.1 microfarad to about 5 microfarads and small capacitors are those below 0.1 microfarad.

1000 nanofarads ('nF') = 1 microfarad.

1000 picofarads ('pF') = 1 nanofarad

So:

0.01 microfarad can be written as 10nF

0.1 microfarad can be written as 100nF

0.1nF can be written as 100pF

Capacitors larger than 1 microfarad tend to be 'polarised'. In other words, the capacitor has a '+' connector and a '-' connector, and it does matter which way round you connect it. The larger capacitors have a voltage rating and this should **not** be exceeded as the capacitor can be damaged and possibly even totally destroyed. Capacitors can be added together, but surprisingly, they add in the reverse way to resistors:

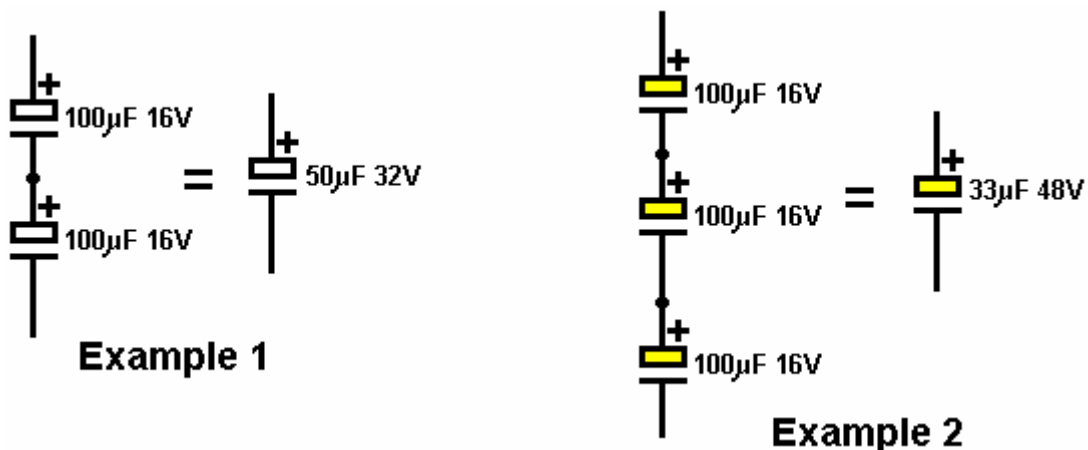

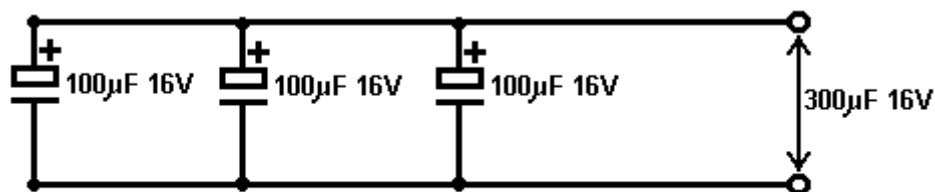

Example 3

If two capacitors are wired in series, as shown in Example 1 above, the overall capacity is reduced while the voltage rating increases. The reduction in capacitance is given by:

$$1/C_t = 1/C_1 + 1/C_2 + 1/C_3 + \dots$$

In Example 1, then, $1/\text{total capacitance} = 1/100 + 1/100$ or $1/C_t = 2/100$ or $1/C_t = 1/50$ so the overall capacitance reduces from 100 microfarads to 50 microfarads. The advantage in wiring the capacitors like this is that the voltage rating has now increased to 32V (16V across each of the capacitors).

In Example 2, the overall capacitance has reduced to a third of 100 microfarads but the voltage rating has tripled.

In Example 3, the capacitors are wired in parallel. The voltage rating is unchanged but the overall capacitance is now the sum of the three capacitors, namely 300 microfarads.

There is no need for the capacitors to have similar values, there are merely shown that way in the examples to make the arithmetic easier and not distract you from the ways in which the capacitors interact together.

Occasionally, a circuit needs a large capacitor which is not polarised. This can be provided by placing two polarised capacitors back-to-back like this:

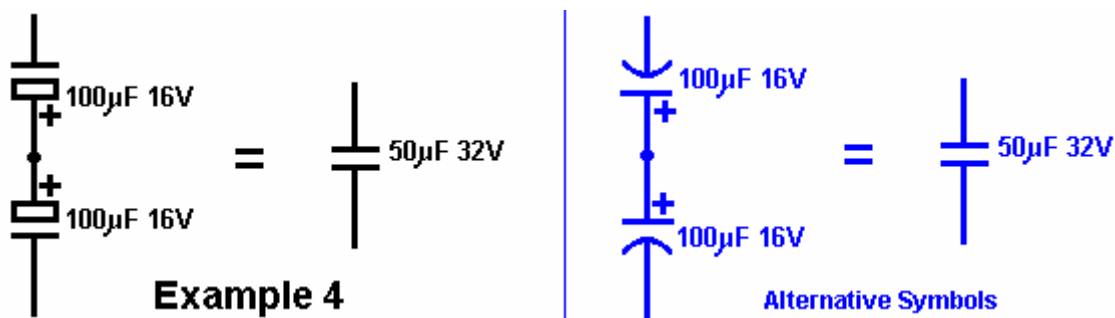

Example 4

Alternative Symbols

When the capacitors are connected this way, it does not matter which end of the pair is connected to the positive side of the circuit and which to the negative side.

Large capacitors usually have their capacitance and voltage printed on the outside of the capacitor, but small capacitors are usually far too tiny for that to be an option. So, a code very much like that used for resistors is used for small capacitors. The code is a 2-digit code for capacitors up to 100 picofarads and for higher values it is a 3-digit code where the first two digits are the numerical value of the capacitor in picofarads and the third digit is the number of zeros following the two digits. One thousand picofarads (pF) is one nanofarad (nF) and one thousand nanofarads is one microfarad. These are some common values:

Value	Code	Value	Code
10 pF	10	2.2 nF	222
22 pF	22	4.7 nF	472
47 pF	47	10 nF	103
100 pF	101	22 nF	223
220 pF	221	47 nF	473
470 pF	471	100 nF	104
1 nF	102	220 nF	224

The time has come for a serious warning: High voltages are very, very dangerous. Do not become so familiar with them that you treat them casually. **High voltages can kill you.** Capacitors are capable of building up high voltages and some good makes can hold the charge for several days.

In particular, do **not** try to make adjustments to, or take parts from, the inside of a TV set. A black and white TV set uses 18,000 Volts on the magnetic coils used to create the moving picture on the tube. A capacitor inside the set may well have that voltage on it three days after the set was last used. Don't fool around inside a TV set, it could kill you quick, or if you are really unlucky, it could injure you for life. A colour TV set uses 27,000 Volts to operate the coils inside it and that will fry you in jig time if you touch it.

Also, please don't think that you are safe if you don't quite touch it; 27,000 volts can jump across a gap to your hand. If you try to discharge a TV capacitor using a metal screwdriver with a wooden handle, please ensure that you medical insurance is up to date before you do it. You can receive a hefty shock through the screwdriver handle.

Voltages up to 24 Volts should be quite safe. **However**, some circuits will generate very high voltages even though the battery driving the circuit is low voltage. A standard off-the-shelf inverter circuit produces 240 Volts AC from a 12 Volt battery. Just because the battery is only 12 Volts does **not** mean that the circuit is not dangerous. Circuits which have inductors in them can produce high voltages, especially if they contain large capacitors. The voltage which produces the spark in your car engine is very high and it comes from the 12-volt car battery. You know enough about this by now, so **pay attention!**

The more advanced stuff:

You do not need to bother with this section if you are just starting out with some basic switching circuits of the type already described in this tutorial, so please feel free to skip this section and move on to the "Prototype Construction" section which you will find immediately useful.

This section is a lightweight introduction to Alternating Current circuits and pulsed DC circuits. Let me stress again that I am mainly self-taught and so this is just a general introduction based on my present understanding.

AC Power Factors.

Alternating Current, generally called "AC" is called that because the voltage of this type of power supply is not a constant value. A car battery, for instance, is DC and has a fairly constant voltage usually about 12.8 volts when in it's fully charged state. If you connect a voltmeter across a car battery and watch it, the voltage reading will not change. Minute after minute it says exactly the same because it is a DC source.

If you connect an AC voltmeter across an AC power supply, it too will give a steady reading, but it is telling a lie. The voltage is changing all the time in spite of that steady meter reading. What the meter is doing is **assuming** that the AC waveform is a sine wave like this:



and based on that assumption, it displays a voltage reading which is called the "Root Mean Square" or "RMS" value. The main difficulty with a sine wave is that the voltage is below zero volts for exactly the same length of time as it is above zero volts, so if you average it, the result is zero volts, which is not a satisfactory result because you can get a shock from it and so it can't be zero volts, no matter what the arithmetical average is.

To get over this problem, the voltage is measured thousands of times per second and the results squared (that is, the value is multiplied by itself) and then those values are averaged. This has the advantage that when the voltage is say, minus 10 volts and you square it, the answer is plus 100 volts. In fact, all of the answers will be positive, which means that you can add them together, average them and get a sensible result. However, you end up with a value which is far too high because you squared every measurement, and so you need to take the square root of that average (or "mean") value, and that is where the fancy sounding "Root Mean Square" name comes from – you are taking the (square) root of the (average or) mean value of the squared measurements.

With a sine wave like this, the voltage peaks are 41.4% higher than the RMS value which everyone talks about. This means that if you feed 100 volts AC through a rectifier bridge of four diodes and feed it into a capacitor the

capacitor voltage will **not** be 100 volts DC but instead it will be 141.4 volts DC and you need to remember that when choosing the voltage rating of the capacitor. In that instance I would suggest a capacitor which is made to operate with voltages up to 200 volts.

You probably already knew all of that, but it may not have occurred to you that if you use a standard AC voltmeter on a waveform which is **not** a sine wave, that the reading on the meter is most unlikely to be correct or anywhere near correct. So, please don't merrily connect an AC voltmeter across a circuit which is producing sharp voltage spikes like, for instance, one of John Bedini's battery pulsing circuits, and think that the meter reading means anything (other than meaning that you don't understand what you are doing).

You will, hopefully, have learned that power in watts is determined by multiplying the current in amps by the voltage in volts. For example, 10 amps of current flowing out of a 12 volt power supply, represents 120 watts of power. Unfortunately, that only holds true for circuits which are operating on DC, or AC circuits which have only resistors in them. The situation changes for AC circuits which have non-resistive components in them.

The circuits of this type which you are likely to come across are circuits which have coils in them, and you need to think about what you are doing when you deal with these types of circuit. For example, consider this circuit:

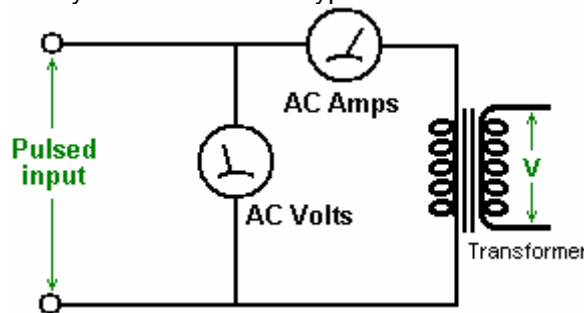

This is the output section of a prototype which you have just built. The input to the prototype is DC and measures at 12 volts, 2 amps (which is 24 watts). Your AC voltmeter on the output reads 15 volts and your AC ammeter reads 2.5 amps and you are delighted because $15 \times 2.5 = 37.5$ which looks much bigger than the 24 watts of input power. **But**, just before you go rushing off to announce on YouTube that you have made a prototype with COP = 1.56 or 156% efficient, you need to consider the real facts.

This is an AC circuit and unless your prototype is producing a perfect sine wave, then the AC voltmeter reading will be meaningless. It is just possible that your AC ammeter is one of the few types that can accurately measure the current no matter what sort of waveform is fed to it, but it is distinctly possible that it will be a digital meter which assesses current by measuring the AC voltage across a resistor in series with the output, and if that is the case, it will probably be assuming a sine wave. The odds are that both readings are wrong, but let's take the case where we have great meters which are reading the values perfectly correctly. Then the output will be 37.5 watts, won't it? Well, actually, no it won't. The reason for this is that the circuit is feeding the transformer winding which is a coil and coils don't work like that.

The problem is that, unlike a resistor, when you apply a voltage across a coil the coil starts absorbing energy and feeding it into the magnetic field around the coil, so there is a delay before the current reaches its maximum value. With DC, this generally doesn't matter very much, but with AC where the voltage is changing continuously, it matters a great deal. The situation can be as shown in this graph of both voltage and current:

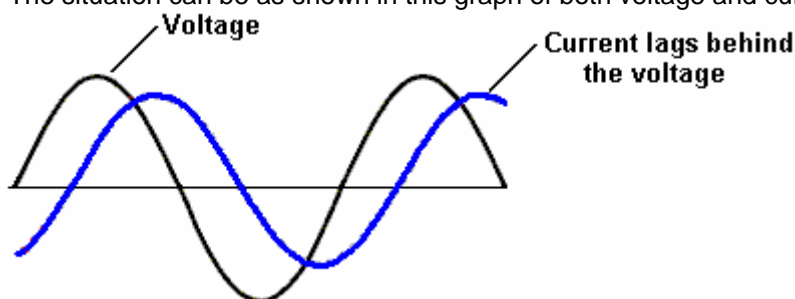

At first, this does not look like any great problem, but it has a very significant effect on the actual power in watts. To get the 37.5 watts output which we were talking about earlier, we multiplied the average voltage level by the average current level. But these two values do not occur at the same time and that has a major effect.

As this can be a little difficult to see, let's take the peak values rather than the averages as they are easier to see. Let's say that in our example graph that the voltage peak is 10 volts and the current peak is 3 amps. If this were

DC we would multiply them together and say that the power was 30 watts. But with AC, this does not work due to the timing difference:

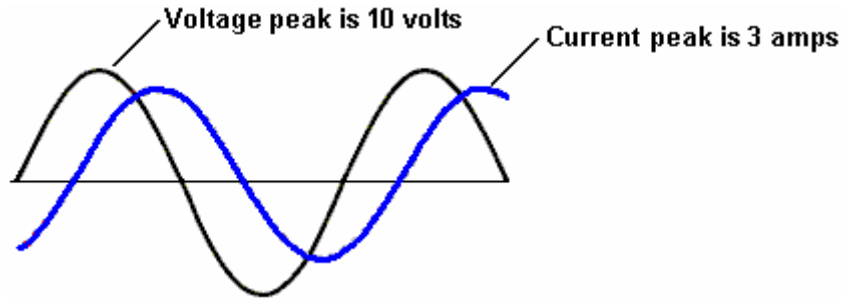

When the voltage is peaking, the current is nowhere near its peak value of 3 amps:

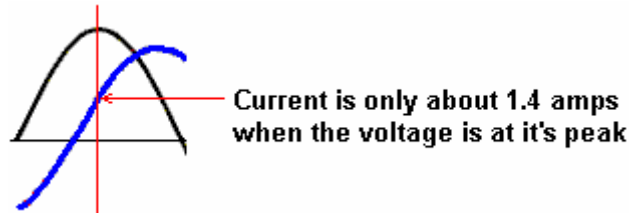

As a result of this, instead of getting our expected peak power at the top of the voltage peak, the actual power in watts is very much lower – less than half of what we were expecting. Not so good, but it gets worse when you look at the situation more closely. Take a look at what the voltage is when the current crosses the zero line, that is, when the current is zero. The output power is zero when the current is zero but this occurs when the voltage is at a very high value:

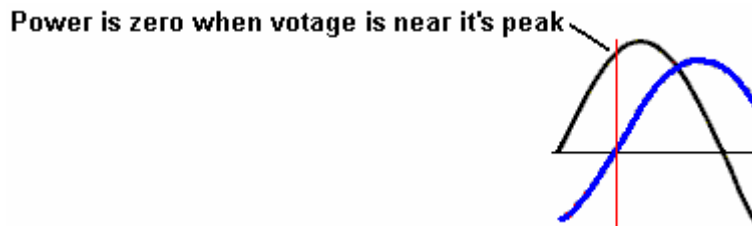

The same goes for when the voltage is zero. When the voltage is zero, then the power is also zero, and you will notice that this occurs when the current is at a high value:

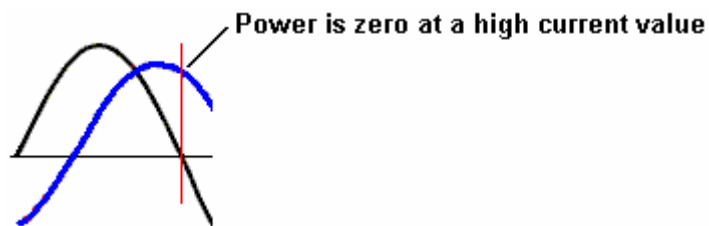

The power is **not** the average current multiplied by the average voltage if there is a coil involved in the circuit – it will be less than that by an amount known as the “power factor” and I’ll leave you to work out why it is called that.

So, how do you determine what the power is? It is done by sampling the voltage and current many times per second and averaging those combined results:

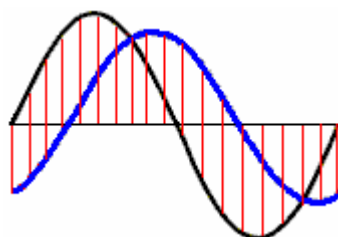

Both the voltage and the current are sampled at the times indicated by the vertical red lines and those figures are used to calculate the actual power level. In this example, only a few samplings are shown, but in practice, a very large number of samples will be taken. The piece of equipment which does this is known as a wattmeter as it measures watts of power. The sampling can be done by windings inside the instrument, resulting in an instrument which can be damaged by overloading without the needle being anywhere near full deflection, or it can be done by digital sampling and mathematical integration. Most digital sampling versions of these meters only operate at high frequencies, typically over 400,000 cycles per second. Both varieties of wattmeter can handle any waveform and not just sine waves.

The power company supplying your home measures the current and assumes that the full voltage is present all of the time that the current is being drawn. If you are powering a powerful electric motor from the mains, then this current lag will cost you money as the power company does not take it into account. It is possible to correct the situation by connecting one or more suitable capacitors across the motor to minimise the power loss.

With a coil (fancy name “inductor” symbol “L”), AC operation is very different to DC operation. The coil has a DC resistance which can be measured with the ohms range of a multimeter, but that resistance does not apply when AC is being used as the AC current flow is **not** determined by the DC resistance of the coil alone. Because of this, a second term has to be used for the current-controlling factor of the coil, and the term chosen is “impedance”. The wire in any coil has a resistance and that opposes current flow through the coil irrespective of whether the voltage applied to the coil is DC or AC. The capacitance between the neighbouring turns of wire in a coil, introduces a feature of the coil which “impedes” AC current flow through the coil and the amount of that impedance depends on the frequency of the AC voltage being applied to the coil.

The impedance of a coil depends on it’s size, shape, method of winding, number of turns and core material. If the core is made up of iron or steel, (usually thin layers of iron which are insulated from each other), then it can only handle low frequencies. You can forget about trying to pass 10,000 cycles per second (“Hz”) through the coil as the core just can’t change it’s magnetisation fast enough to cope with that frequency. A core of that type is ok for the very low 50 Hz or 60 Hz frequencies used for mains power, which are kept that low so that electric motors can use it directly.

For higher frequencies, ferrite can be used for a core and that is why some portable radios use ferrite-rod aerials, which are a bar of ferrite with a coil wound on it. For higher frequencies (or higher efficiencies) iron dust encapsulated in epoxy resin is used. An alternative is to not use any core material and that is referred to as an air-core coil. These are not limited in frequency by the core but they have a very much lower inductance for any given number of turns. The efficiency of the coil is called it’s “Q” (for “Quality”) and the higher the Q factor, the better. The resistance of the wire lowers the Q factor.

A coil has inductance, and resistance caused by the wire, and capacitance caused by the turns being near each other. However, having said that, the inductance is normally so much bigger than the other two components that we tend to ignore the other two. Something which may not be immediately obvious is that the impedance to AC current flow through the coil depends on how fast the voltage is changing. If the AC voltage applied to a coil completes one cycle every ten seconds, then the impedance will be much lower than if the voltage cycles a million times per second.

If you had to guess, you would think that the impedance would increase steadily as the AC frequency increased. In other words, a straight-line graph type of change. That is not the case. Due to a feature called resonance, there is one particular frequency at which the impedance of the coil increases massively. This is used in the tuning method for AM radio receivers. In the very early days when electronic components were hard to come by, variable coils were sometimes used for tuning. We still have variable coils today, generally for handling large currents rather than radio signals, and we call them “rheostats” and some look like this:



These have a coil of wire wound around a hollow former and a slider can be pushed along a bar, connecting the slider to different winds in the coil depending on its position along the supporting bar. The coil connections are then to the slider and to one end of the coil. The position of the slider effectively changes the number of turns of wire in the part of the coil which is in the circuit. Changing the number of turns in the coil, changes the resonant frequency of that coil. AC current finds it very, very hard to get through a coil which has the same resonant frequency as the AC current frequency. Because of this, it can be used as a radio signal tuner:

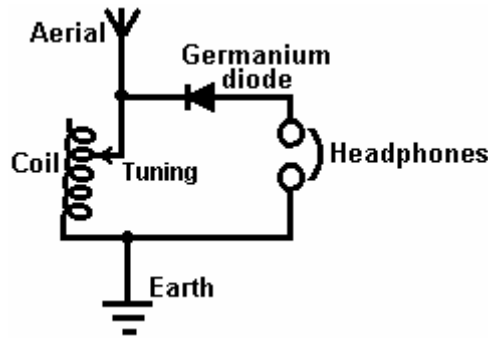

If the coil's resonant frequency is changed to match that of a local radio station by sliding the contact along the coil, then that particular AC signal frequency from the radio transmitter finds it almost impossible to get through the coil and so it (and only it) diverts through the diode and headphones as it flows from the aerial wire to the earth wire and the radio station is heard in the headphones. If there are other radio signals coming down the aerial wire, then, because they are not at the resonant frequency of the coil, they flow freely through the coil and don't go through the headphones.

This system was soon changed when variable capacitors became available as they are cheaper and more compact. So, instead of using a variable coil for tuning the radio signal, a variable capacitor connected across the tuning coil did the same job:

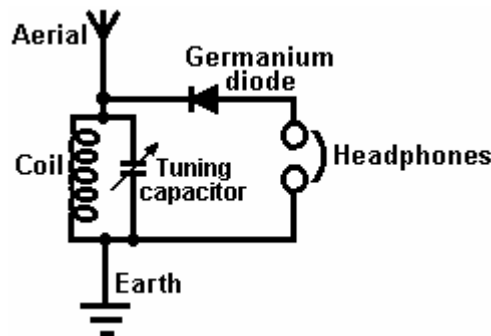

Resonance.

While the circuit diagram above is marked "Tuning capacitor" that is actually quite misleading. Yes, you tune the radio receiver by adjusting the setting of the variable capacitor, **but**, what the capacitor is doing is altering the resonant frequency of the coil/capacitor combination and it is the resonant frequency of that combination which is doing exactly the same job as the variable coil did on its own.

This draws attention to two very important facts concerning coil/capacitor combinations. When a capacitor is placed across a coil "in parallel" as shown in this radio receiver circuit, then the combination has a very high impedance (resistance to AC current flow) at the resonant frequency. But if the capacitor is placed "in series" with the coil, then there is nearly zero impedance at the resonant frequency of the combination:



This may seem like something which practical people would not bother with, after all, who really cares? However, it is a very practical point indeed. In Chapter 3, some of the very high-power devices produced by Don Smith are described. Typically, he uses an off-the-shelf neon-tube driver module as an easy way to provide a high-voltage, high-frequency AC current source, typically, 6,000 volts at 30,000 Hz. He then feeds that power into a Tesla Coil which is itself, a power amplifier. The arrangement is like this:

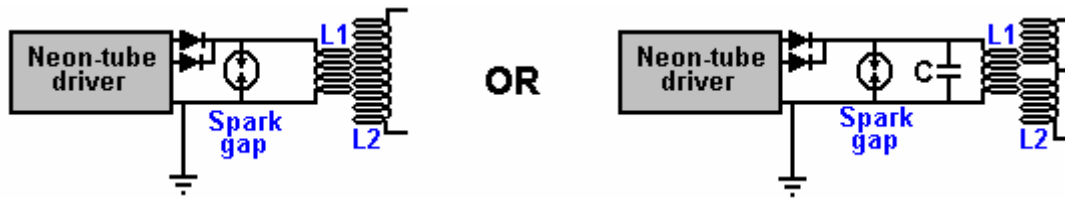

People who try to replicate Don's designs tend to say "I get great sparks at the spark gap until I connect the **L1** coil and then the sparks stop. This circuit can never work because the resistance of the coil is too low".

If the resonant frequency of the **L1** coil does not match the frequency being produced by the neon-tube driver circuit, then the low impedance of the **L1** coil will definitely pull the voltage of the neon-tube driver down to a very low value. But if the **L1** coil has the same resonant frequency as the driver circuit, then the **L1** coil (or the **L1** coil/capacitor combination shown on the right, will have a very high resistance to current flow through it and it will work well with the driver circuit. So, no sparks, means that the coil tuning is off. It is the same as tuning a radio receiver, get the tuning wrong and you don't hear the radio station.

Choosing components which are not specified.

Some people find it difficult to select a suitable component where the exact component is not specified or where an alternative has to be selected, so perhaps a few general pointers might be helpful. The reason why component values are omitted may well be because a very wide range of alternative values can be used and if one particular is specified, the newcomers to electronics feel that they **have** to use that one value or the circuit will not work, (which is almost never the case). For example, I have been asked if a capacitor rated at 25V could be used instead of the same value capacitor rated at 16V shown in the circuit, to which the answer is 'yes, most definitely'. The lower voltage rating is adequate and the component cheaper to buy, but if one of a higher voltage rating is available, then it can be used.

With **capacitors**, you need to consider the physical size and wire connections, the capacitance, the voltage rating, and the leakage. The cost and size of a capacitor is directly related to it's voltage rating, and once the voltage rating exceeds that normally used, the price shoots up rapidly as the sales volume reduces rapidly, which in turn, discourages further sales. This sometimes causes circuit builders to connect chains of cheaper capacitors together to make a smaller-capacity high-voltage capacitor. In the case of Tesla Coil builders, they then may connect several of these chains in parallel to boost the capacitance.

If the voltage rating is exceeded (usually by a very large amount), the capacitor will be damaged and become either a short-circuit, or more likely, an open circuit. Either way, it will never work as a capacitor again. In a household circuit, where the capacitor is being used as part of the power supply to the circuit, the voltage rating does not need to be much higher than the supply voltage, with say, 16V being used for a 12V circuit. You could use a capacitor rated at 25V, 40V, 63V, 100V or 400V and it would work perfectly well, but it will be much larger and have cost much more. But, if you have one sitting around and not being used, there is no reason why you should not use it rather than paying to buy another one.

If the capacitor is being used in a timing circuit where a high-value resistor is feeding current to it, then the leakage current of the capacitor becomes very important. Electrolytic capacitors are seldom suitable for such an application as they have a small, unpredictable leakage current which will vary with the age of the capacitor. For accurate timing with a capacitor, ceramic, polypropylene, mylar or tantalum should be used.

The voltage rating for an electrolytic capacitor is for DC, so if you use it for limiting current in an AC power supply, that is, where the current flows through the capacitor rather than the capacitor being placed across the supply and is acting to combat ripple, then great care is needed. The capacitor will heat up due to the power flowing through it, and it is possible for an electrolytic capacitor used in that way to rupture or 'explode' due to the electrolyte boiling. Instead, you need to use the very much more expensive oil-filled can capacitors (as shown near the end of chapter 10). That style of usage is unusual for home constructors.

With bi-polar **transistors**, you need to use commonsense. Suppose a 555 timer chip is required to power a transistor which controls a relay:

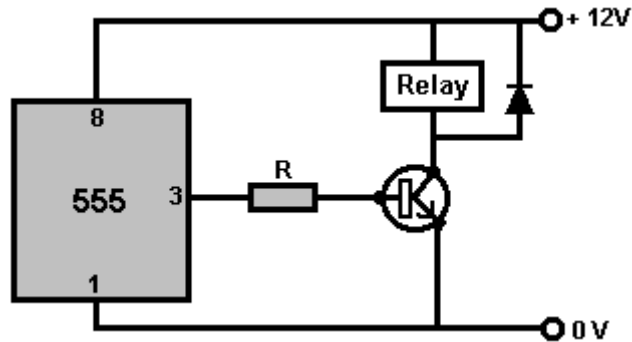

For the moment, we will ignore the fact that the 555 could drive the relay directly without the need for a transistor. let's say that the relay draws a current of 30 mA when connected to a 12V supply. Therefore, the transistor needs to be able to handle a current of 30 mA. Any small switching transistor such as the BC109 or 2N2222 can easily handle that current. The transistor also needs to be able to handle 12 volts. If in doubt, look up the characteristics of your choice of transistor at <http://www.alldatasheet.co.kr/> by entering the transistor name 'BC109' or whatever in the entry box at the top of the screen and clicking on the button to the right of it. Eventually, it will let you download a pdf document specifying the transistor, and that will show you the voltages which the transistor can handle. Both of the above transistors can handle far more than 12V.

The next question is, 'can the transistor switch fast enough to work in this circuit?' and the data sheet will show that they can switch on and off a million times per second. As the relay can only switch on and off a few times per second, the transistor can easily operate fast enough to handle the switching.

Next, we need to know what size of resistor would be suitable. The data sheet will also show the DC current gain of the transistor. This is usually marked as "hfe" and for these transistors is likely to be a minimum of, say, 200. This means that the current flowing into the base of the transistor needs to be one two-hundredth of the relay's 30 mA which is 0.15 mA. The resistor will have about +11 volts at pin 3 of the 555 timer and around +0.7 volts at the base of the transistor when it is switched fully on. That means that the resistor will have about 10.3 volts across it when the relay is switched on:

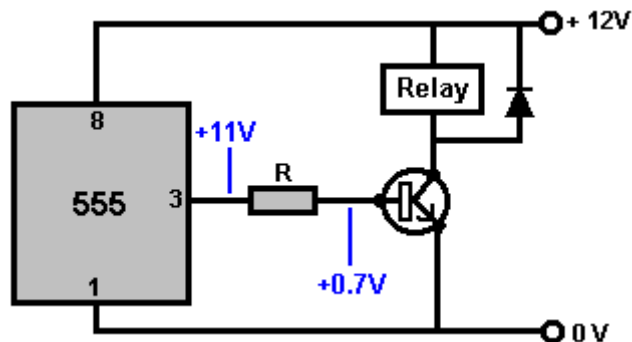

So, what size of resistor will have 0.15 mA flowing through it when there is a 10.3-volt drop across it? We know that a 1K resistor passes 1mA per volt and so would pass 10.3 mA with 10.3 volts across it. That is far more than we need. A 10K resistor would pass 1.03 mA which is still far too much but certainly could be used. As it is a resistor, we can use Ohm's Law: $R = V / A$ (Ohms equals Volts over Amps), or $R = 10.3 / 0.00015$ which is 68K. So, any resistor between 68K and perhaps 15K should work well.

The diode is there to protect the transistor from excessive voltage caused by the coil of the relay. When a coil is switched off suddenly, it generates a reverse voltage which can be hundreds of volts, pulling the collector of the transistor far above the +12V power supply line. When that starts to happen, it effectively reverses the diode direction, allowing it to conduct and short-circuit that big voltage spike:

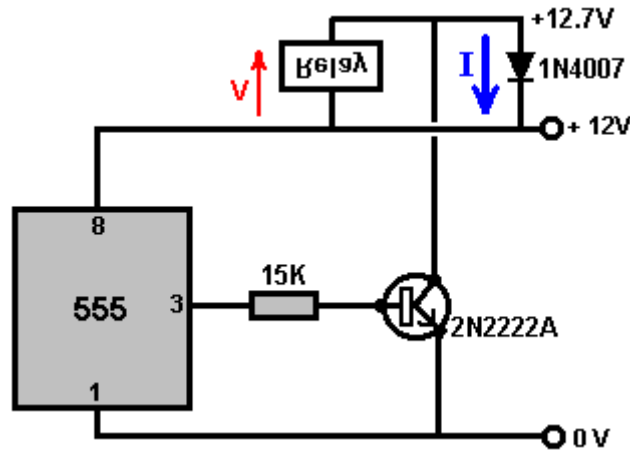

Due to the short-circuiting, the voltage can't get any higher and the current through the diode is not large, so most diodes such as the popular and cheap 1N4001 or 1N4007 types can be used.

When a transistor is connected like that and switched on, it is effectively a short-circuit between its collector and emitter, and that places the full 12 volts across the relay, powering it very solidly. This connection method is called a "common-emitter" circuit because all of the transistors used have their emitters all wired in common to the 0V line. An alternative arrangement is the "emitter-follower" circuit:

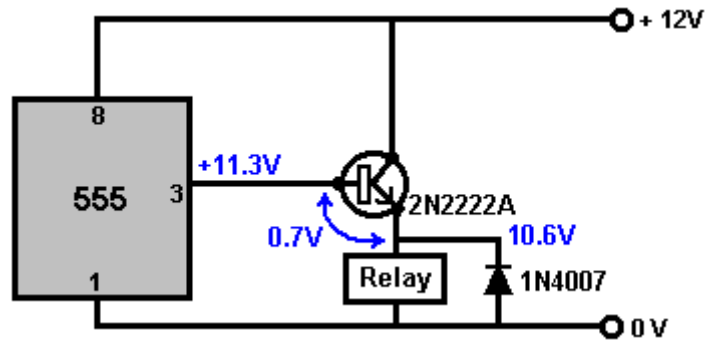

With this circuit arrangement, the emitter of the transistor "follows" the voltage on pin 3 of the 555 timer. It is always a constant voltage below it, typically about 0.7 volts. The output of the 555 timer has a maximum of about 0.7V below the supply voltage, and so its maximum value is about 11.3V in this circuit. The transistor drops that by a further 0.7V, which means that the relay only gets about 10.6V across it instead of the full 12V of the supply, which means that it should be a 10-volt relay rather than a 12-volts relay.

Those are the easy cases because the 555 timer can supply at least 200 mA through its output pin, while keeping the output voltage steady. That is not the case with simple transistor circuits. Take a situation like this:

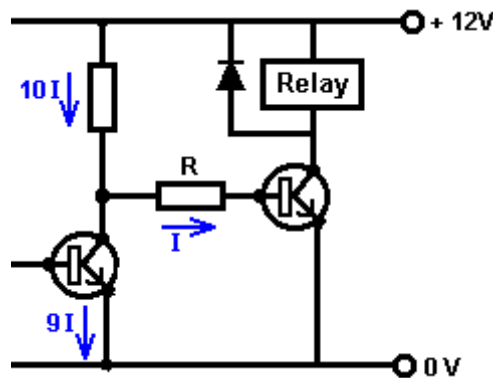

For audio work - microphone pre-amplifiers and the like – the rule of thumb is that the current flowing through the first transistor should be at least ten times the current required by the base of the second transistor in order not to drag down and distort the audio waveform.

Relay switching is not so critical but the same general principle applies and attention needs to be paid to the collector resistor of the preceding transistor. For example, if the current flowing through the preceding transistor is small, say, 0.5 mA and the output transistor needs 1.5 mA flowing into its base, then there can be a problem. In this circuit, for example:

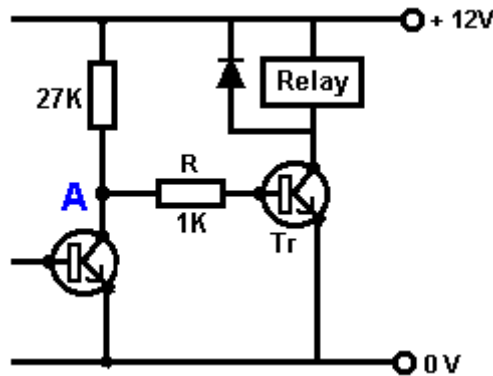

Here, the voltage at point "A" goes high because the first transistor switches off and so becomes the same as a resistor of 1Meg or more. Normally, that resistance is so much greater than the 27K of its resistor, that the voltage at point "A" would be nearly +12V, but if you were to connect the resistor "R" of just 1K in value, then the situation is changed completely. The base of "Tr" can't rise above 0.7V. The first transistor can be ignored due to its very high resistance. That leaves a voltage-divider pair of resistors, the 27K and the 1K, with 11.3 volts across them, stopping the voltage at point "A" from rising above 1.13V instead of the original 12V and transistor "Tr" will only get 0.43 mA instead of the 1.5 mA which was wanted. The transistor "Tr" has effectively a 28K resistor feeding it current from the +12V rail.

One solution would be to raise the current through the first transistor by using a resistor a good deal smaller than the present 27K. Another option is to lower the input current requirement of transistor "Tr" by making it a Darlington pair or by using a transistor with a much higher gain.

Constructing Prototypes.

The main options for building a prototype circuit are:

1. A (plug-in) breadboard
2. Electrical screw connector strips.
3. Stripboard
4. A printed circuit board.

1. The typical breadboard unit consists of a matrix of clip holes wired in strips, into which component leads can be pushed to make a circuit. In my opinion, they are best avoided as it takes quite some effort to implement any significant circuit using them, some components do not fit well in the sockets which are small enough to take DIL IC packages, and when you do get a circuit working well on the breadboard, there is no guarantee that it will work well when you attempt to move it to a permanent soldered board:

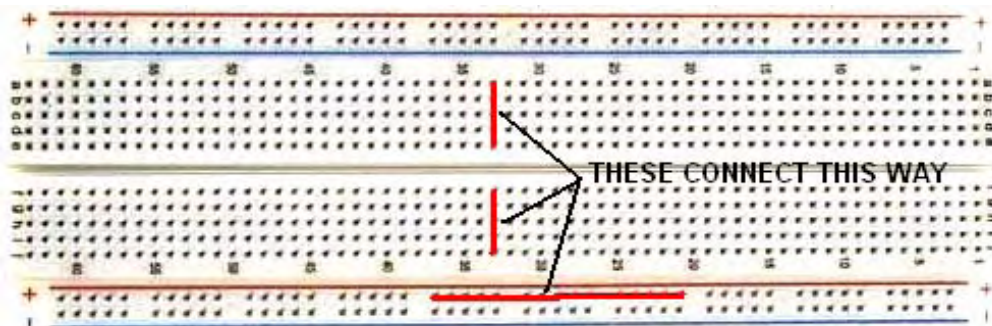

While a plastic board of this type looks as if it should be quick and easy to use, I have never found it to be so ever since the boards were scaled down in size to take the closely-spaced pins of integrated circuits ("chips"). It is generally difficult to lay the components out in the same pattern as the circuit diagram, and if they are not, then it becomes slow to follow the circuit through on the breadboard layout.

2. The local hardware shop has cheap screw connectors which can be very effective. These come in several sizes and the smaller ones are very convenient for constructing transistor circuitry. They look like this:



Circuits can be assembled very easily, using these connectors and an example might be one of the John Bedini battery pulsing circuits which might have a layout like this:

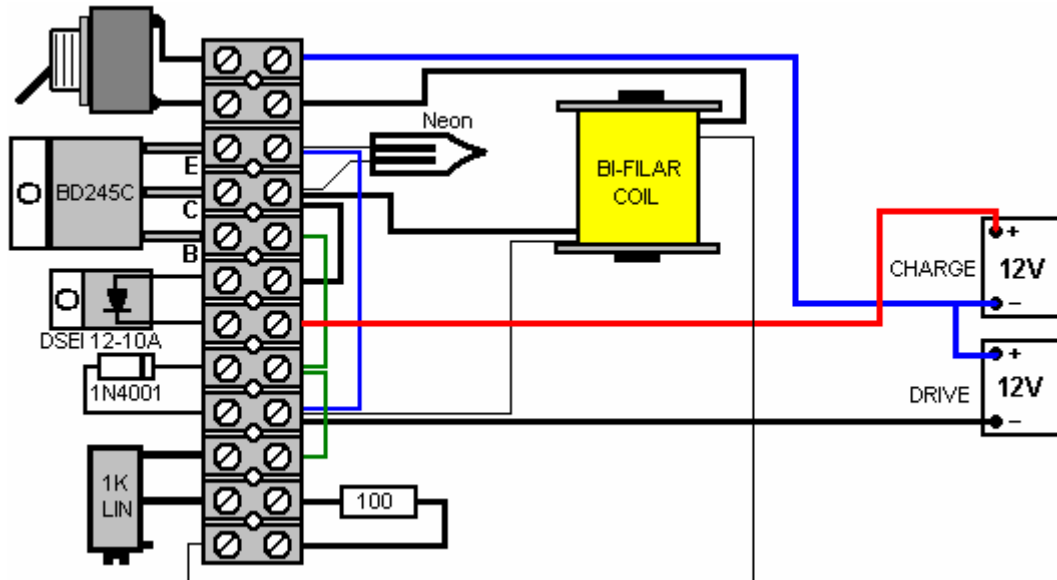

I have built this circuit using this style of construction and it was very successful indeed, being very quick and easy to construct and it proved to be very tough and effective over a long period of use. The plastic strip has a hole between each connector strip and that allows you to bolt the strip to a base board on which you mount other components, in this case, the pulsing coil and the rotor with the magnets attached. Each connection block can take two or three wires. The wires need to have the insulation removed and the wires scraped clean and shiny if they are not already in that state. If more than one multi-strand wire is being put into one side of a connector, then it is usually best to twist the wires together before tightening the clamping screw. If you want, you can give the twisted wires a thin coat of solder, but this has to be done neatly to avoid producing a joint which is too large to fit into the connector. One connector can be cut out of the strip quite easily, using a pair of scissors or a craft knife. Single connectors can join two wires very effectively without the need to solder them.

3. Stripboard, usually called 'Veroboard' even if it is not made by Vero, is a quick and satisfactory method, although you have to make very tiny solder joints. Please be aware that the fumes from the burning resin when soldering are most definitely not good for your health and should be avoided by making sure that the ventilation is adequate.

4. A printed circuit board is feasible for a one-off prototype and making one will increase your production skills, so it is also a reasonable option if you have the etching and drilling equipment to hand. Buying all of the necessary equipment if you do not have any, can cost a fair amount, but the skills gained are significant and the finished boards looks very professional.

There are several other methods of construction, and many varieties of construction board and stripboard. Simple stripboard will be used in the following descriptions, although the method does apply to many different styles of construction.

The first step is to produce a layout for the components on the board. When designing the layout provision should be made for drilling holes to allow the completed board to be bolted to its case using bolts and insulating pillars to keep the soldered joints clear of all other surfaces.

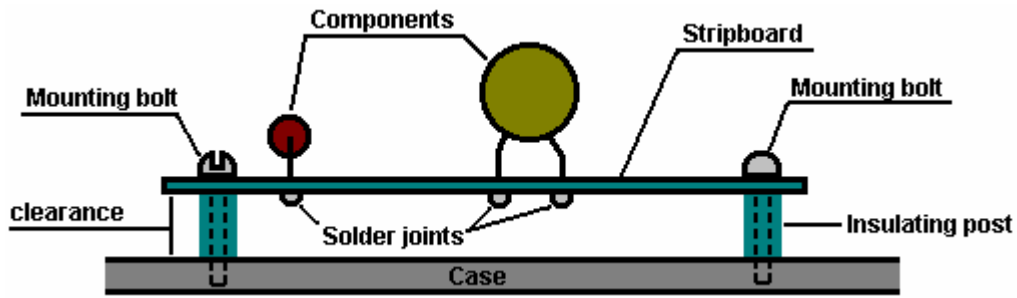

The circuit diagram of the circuit to be built is the starting point. You might wish to draw a light grid of lines to represent the matrix of holes in the strip board. This helps to visualise the run of the copper strips and the sketch can be made to show the exact number of holes available on the piece of strip board to be used. The strip board looks like this:



So you might wish to produce a layout sketch re-usable drawing like this:

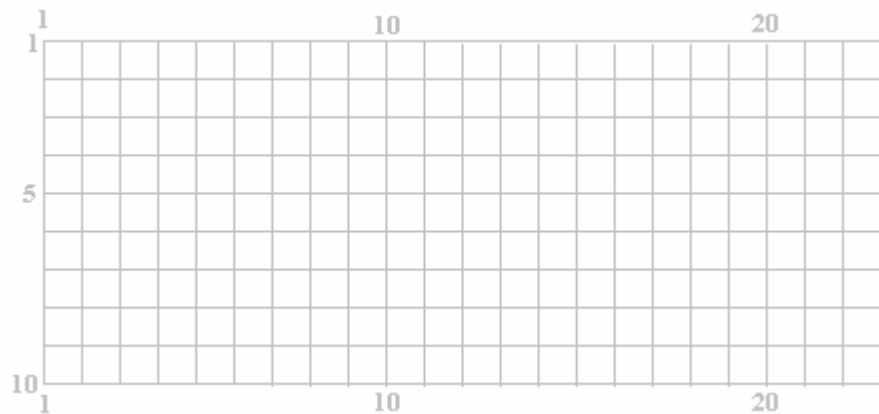

where the horizontal strips are numbered and the vertical lines of holes are also numbered. In this sketch, where the lines cross, represents a hole in the board. The sketch of a possible physical layout can then be prepared and it might look like this when seen from the top although the copper strips on the underside of the board are shown in the sketch:

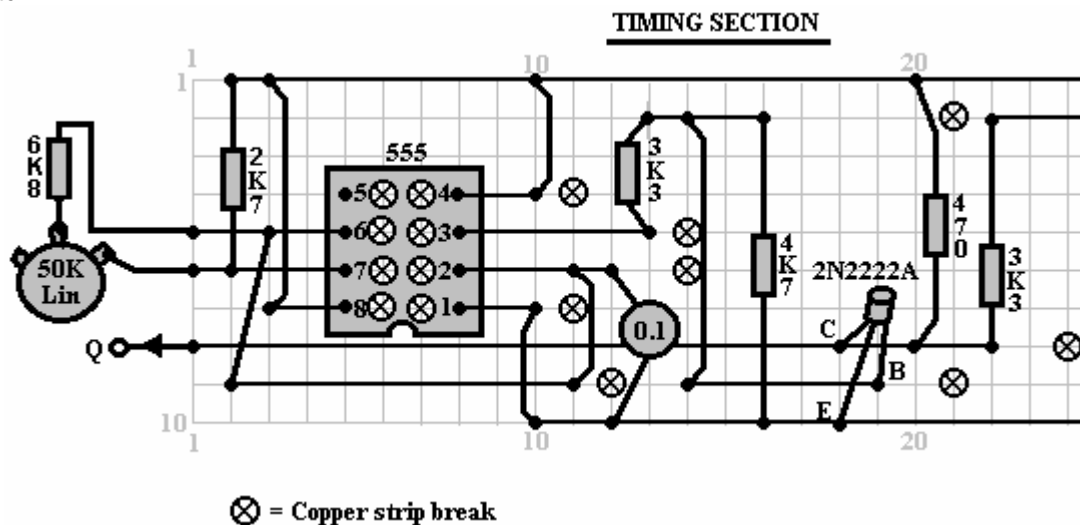

It is very important when producing a sketch like this, that the copper strips making up the circuit are not accidentally used to connect components further along the board, without breaking the copper strip between the

two sections of the board. It helps to mark a copy of the circuit diagram when you are sketching a possible physical layout on the strip board. It might be done like this:

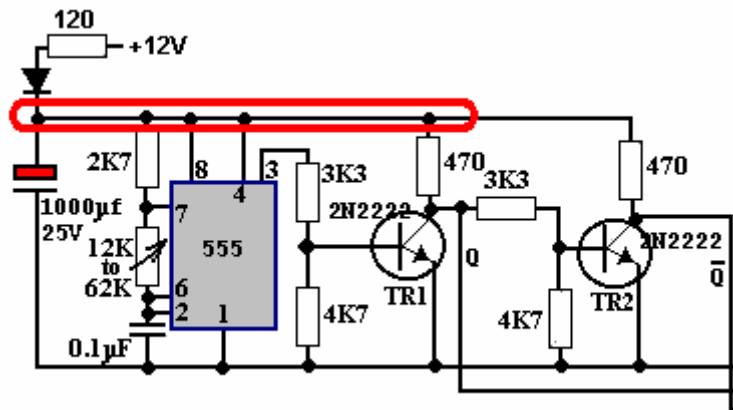

Here, the components just below the diode are ringed to show that they have been marked on the layout sketch and, if necessary, the copper strip broken to isolate the components. A component worth mentioning in passing, is the capacitor marked with red in the circuit diagram. This is a decoupling capacitor, fed from the 12V battery via a resistor and a diode (a diode is not normally used in this part of the circuit).

The decoupling is to provide the 555 chip and drivers with a supply which is reasonably isolated from the heavy current-draw circuit not shown in this small section of the circuit diagram. The pulsating heavy current draw of the rest of the circuit is capable of pulling the battery voltage down slightly many times per second. This creates a voltage ripple on the positive supply line from the battery and to smother the ripple, the resistor and diode are used to feed a large reservoir capacitor which smoothes out the ripple.

The circuit itself is not beyond criticism. Transistor 'TR2' and its associated components are redundant since pin 3 of the 555 chip already supplies the required signal (and with higher drive capacity) so the second output line should be taken directly from pin 3 of the 555 chip. This snippet of circuit is only shown here as an example of marking up a circuit diagram when making a components layout sketch.

As the layout sketch is produced, the circuit diagram should be marked off with a highlighting pen to make sure that every part of the circuit diagram has been successfully copied to the sketch. In the example below, not all of the highlighted strip is shown, since it runs off the small section of the board being shown here:

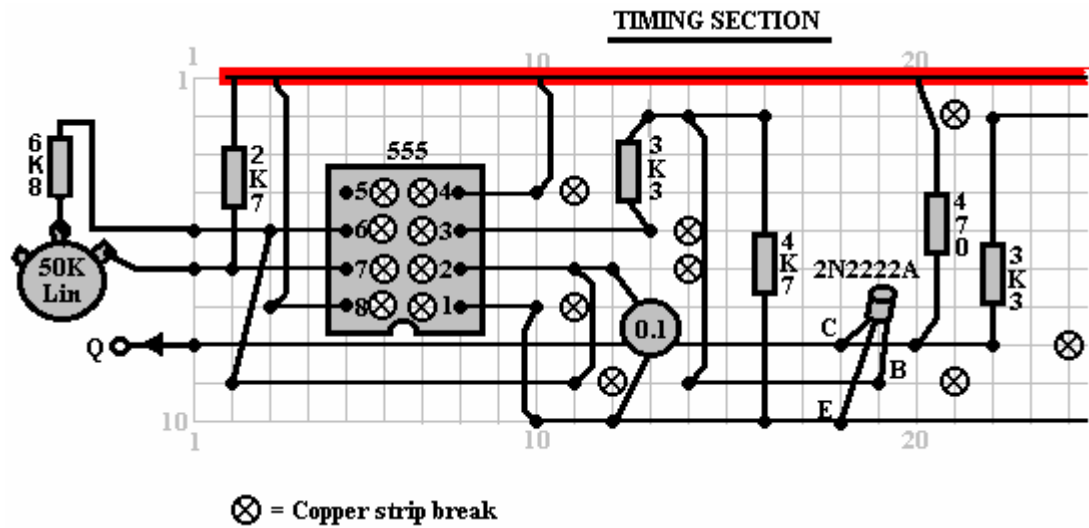

Many electronic components can be damaged by the high temperatures they are subjected to when being soldered in place. I personally prefer to use a pair of long-nosed pliers to grip the component leads on the upper side of the board while making the solder joint on the underside of the board. The heat running up the component lead then gets diverted into the large volume of metal in the pair of pliers and the component is protected from excessive heat. On the same principle, I always use a DIL socket when soldering a circuit board, that way, the

heat has dissipated fully before the IC is plugged into the socket. It also has the advantage that the IC can be replaced without any difficulty should it become damaged.

If you are using CMOS integrated circuits in any construction, you need to avoid static electricity. Very high levels of voltage build up on your clothes through brushing against objects. This voltage is in the thousands of volts range. It can supply so little current that it does not bother you and you probably do not notice it. CMOS devices operate on such low amounts of current that they can very easily be damaged by your static electricity. Computer hardware professionals wear an earthing lead strapped to their wrists when handling CMOS circuitry. There is no need for you to go that far. CMOS devices are supplied with their leads embedded in a conducting material. Leave them in the material until you are ready to plug them into the circuit and then only hold the plastic body of the case and do not touch any of the pins. Once in place in the circuit, the circuit components will prevent the build up of static charges on the chip.

Soldering is an easily-acquired skill. Multi-cored solder is used for electronic circuit soldering. This solder wire has flux resin contained within it and when melted on a metal surface, the flux removes the oxide layer on the metal, allowing a proper electrical joint to be made. Consequently, it is important that the solder is placed on the joint area and the soldering iron placed on it when it is already in position. If this is done, the flux can clean the joint area and the joint will be good. If the solder is placed on the soldering iron and then the iron moved to the joint, the flux will have burnt away before the joint area is reached and the resulting joint will not be good.

A good solder joint will have a smooth shiny surface and pulling any wire going into the joint will have no effect as the wire is now solidly incorporated into the joint. Making a good solder joint takes about half a second and certainly not more than one second. You want to remove the soldering iron from the joint before an excessive amount of heat is run into the joint. It is recommended that a good mechanical joint be made before soldering when connecting a wire to some form of terminal (this is often not possible).

The technique which I use is to stand the solder up on the workbench and bend the end so that it is sloping downwards towards me. The lead of the component to be soldered is placed in the hole in the strip board and gripped just above the board with long-nosed pliers. The board is turned upside down and the left thumb used to clamp the board against the pliers. The board and pliers are then moved underneath the solder and positioned so that the solder lies on the copper strip, touching the component lead. The right hand is now used to place the soldering iron briefly on the solder. This melts the solder on the joint, allowing the flux to clean the area and producing a good joint. After the joint is made, the board is still held with the pliers until the joint has cooled down.

Test Equipment.

When developing new circuitry, it may be convenient to try different values of resistor in some position in the circuit (the resistor value may be dependent on the gain of a transistor or the actual resistance of an ORP12, or some such other situation). For this, it is very convenient to have a resistor-substitution box which allows you to select any standard resistor at the turn of a switch.

These are not readily available on the market. In years gone by, it was possible to buy custom wafer switches, where the number of wafers could be built up to whatever switch size was required, but these do not seem to be available any more. A slightly less convenient method of construction is to use four of these, selected by a second wafer switch:

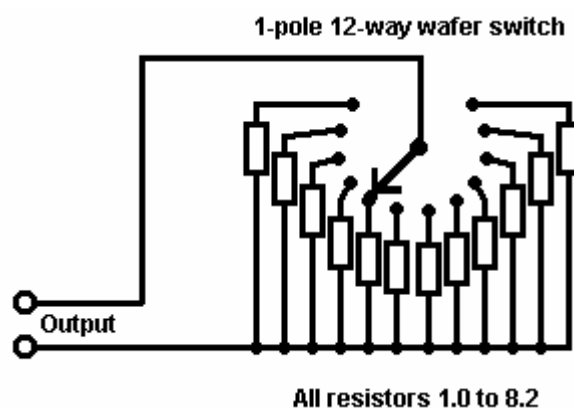

In the above diagram, all of the resistors in one range (100 ohms to 820 ohms, 1K to 8K2, 10K to 82K or 100K to 820K) are wired to a single 12-way switch. The output wires then have any of these standard resistors across

them, depending on the setting of the switch. A second switch can then be used to select several of these groups, while still using the same output wires. When boxed, it might look like this:



It can also be useful to have a versatile signal generator. You can easily construct your own with variable frequency, variable mark/space ratio and optional variable gating. If you do, you might as well make it with a low output impedance so that it can drive devices under test directly rather than having to provide additional buffering. It might look like this:



The really essential item of equipment is a multimeter. These come in many shapes, sizes and varieties and the cost varies enormously. The reliability also varies a great deal. The most reliable and the cheapest is the analogue type which does not use a battery (other than for the occasional measurement of resistance). Although these types are looked down upon nowadays, they are 100% reliable:



The meter shown above is rated at 2,000 ohms per volt, so connecting it to a circuit to make a measurement on the 10V range is the same as connecting a 20K resistor to the circuit. The big brother of this style of equipment is about five times larger and has 30,000 ohms per volt performance, so connecting it on a 10V range is the same as connecting a 300K resistor to the circuit being measured. This one is battery driven, so if you get one of these, may I suggest that you check its accuracy on a regular basis:



The really excellent non-battery (ex-professional) Avo meter multimeters are still available through eBay at affordable prices. These have 30,000 ohms per volt performance and are robust and accurate, having been built to very high standards.

A multimeter uses a 1.5V battery to measure resistance. Ohm's Law is used as the working principle and the operation is:

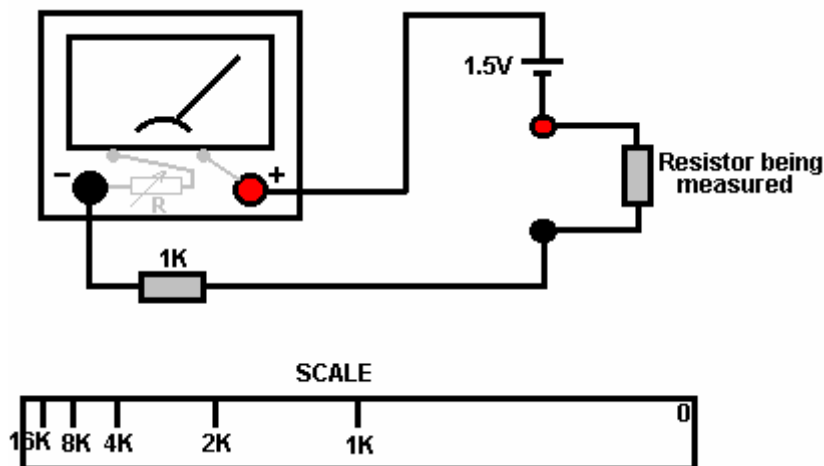

The meter shown in the diagram has a small resistance of its own. This has a small variable resistor added to it. This variable resistor will have a small knob mounted on the face of the multimeter, or it will be a thumbwheel knob projecting slightly from the right hand side of the multimeter case. The 1.5V battery will be positioned inside the multimeter case as is the 1K resistor. To use the resistance ranges, the multimeter probes are touched firmly together to form a short-circuit and the variable resistor adjusted so that the meter points to zero.

For the purpose of this discussion, let us assume that the internal resistance of the meter, when correctly adjusted, is exactly 1K. If the resistor under test is exactly 1K in value, then the current through the meter will be halved and the meter will show a needle deflection half way across the scale. If the resistor under test is 2K, then the current will be one third and the scale marking will be at the 1/3 position from the left. If the resistor is 4K, then there will be one fifth ($1K+4K=5K$) of the full-scale current and the 4K mark will be 20% from the left hand side of the scale.

Two things to notice: firstly, the scale has to read from right to left which can take some getting used to, and secondly, the scale is not linear, with the markings getting closer and closer together and consequently, more difficult to mark and read, the higher the value of the resistor being measured. The bunching up of the scale markings is why the more expensive multimeters tend to have more than one range.

A mains-operated oscilloscope is an excellent piece of equipment to own but they are expensive when new. It is possible to pick one up at a reasonable price second-hand via eBay. An oscilloscope is by no means an essential item of equipment. One of its most useful features is the ability to measure the frequency, and display the shape of a waveform. Most waveforms are of known shape so the frequency is the major unknown. The following meter is not expensive and it displays the frequency of a signal on a digital readout:



So, when you are deciding what multimeter to buy, consider the following points:

1. How reliable is it? If you are opting for a battery driven unit, what happens to the accuracy if the battery starts to run down. Does it display a warning that the battery needs to be replaced? Mains-operated digital multimeters are brilliant but are a problem if you want to make measurements away from the mains.
2. What DC voltage ranges does it have? If you are intending to work mainly with 12V circuits, it is inconvenient for the ranges to be 9V and 30V as successive ranges. Digital meters do not have this problem but the question then is, how accurate are they going to be in day to day use?
3. Transistor testing options you can ignore - you are better off making your own dedicated unit to check transistors if you think you will ever need to do this - you probably won't.
4. Measuring current can be very useful so see what ranges are offered.
5. Measuring capacitance is very useful, especially since many capacitors are not well marked to indicate their value.
6. Measuring the frequency of a waveform could be a significant bonus but the question is; are you every likely to need it?
7. Measuring resistance is very useful. Every meter has it. There is no need to be over fancy on measurement ranges as you usually only need to know the approximate answer - is it a 1K resistor or a 10K resistor?

Look around and see what is available, how much it costs and what appeals to you. It might not be a bad idea to buy a really cheap multimeter and use it for a while to see if it has any shortcomings which are a nuisance, and if so, what improvements you personally want from a more expensive meter.

The 'Bench' Power Supply.

It might be worth getting a fancy bench power supply which allows you to set any voltage you want and which displays the current being drawn by your development circuit:



However, there is no need to spend money on a fancy unit when you can build an excellent unit of your own with voltage stabilisation, adjustable output, metered current, etc. etc. Personally, if developing a circuit to be used with a battery, I believe you are better off powering the development from a battery, that way the characteristics of the battery are included in any tests which you carry out.

If you wish, you can construct a very convenient development test bed power supply system. This has the advantage that you can make it in the most convenient style for your own use. You can also make the protection ultra-sensitive and build in additional circuitry such as transistor tester and resistor substitution box to produce an integrated test bed. You could perhaps use a circuit like this:

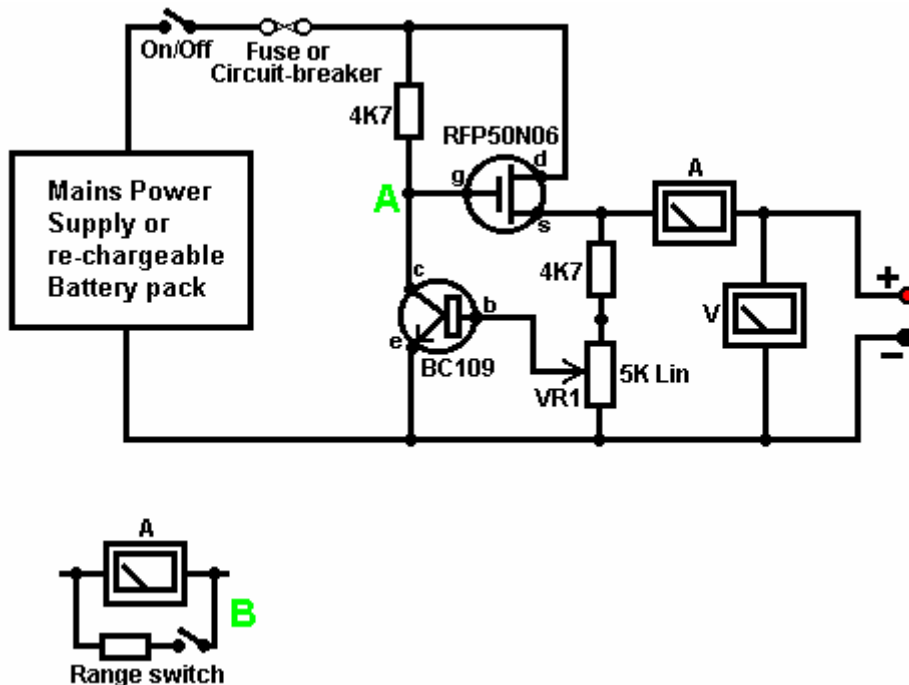

Here, the power is supplied by a pack of re-chargeable Ni-Cad batteries or possibly, a mains unit with voltage stabilisation. As in all actual circuits, the next thing in the circuit is **always** an on/off switch so that the power source can be disconnected immediately should any problem arise. Next, as always, comes a fuse or circuit breaker, so that should the problem be serious, it can disconnect the circuit faster than you can react. If you wish, you can build your own super-accurate adjustable circuit breaker to use in this position.

The two transistors and three resistors form an adjustable, stabilised output. The FET transistor has a high output power handling capacity and a very low input power requirement and so is good for controlling the output voltage.

Resistor 'VR1' is padded with the 4K7 resistor solely to reduce the voltage across the variable resistor. VR1 is adjusted to control the output voltage. If the current draw is increased and the output voltage is pulled down slightly, then the voltage on the base of the BC109 transistor is reduced. This starts to turn the transistor off, raising the voltage at point 'A', which in turn, raises the output voltage, opposing the variation caused by the load.

The output is monitored, firstly by a large milliammeter to show the current draw and secondly, on the output side of the milliammeter, a voltmeter. This allows very close monitoring of the power supplied to the prototype, especially if the milliammeter is placed alongside the prototype. You can build this circuit into a wide flat box which provides a working surface beside the milliammeter.

At point 'B' in the above diagram, a method for altering the current range of the milliammeter by placing a 'shunt' resistor across it. When the switch is closed, some current flows through the resistor and some through the milliammeter. This resistor has a very low value, so you are better off making it yourself. Let's say we wish to double the range of the meter. Solder the switch across the meter and for the resistor use a length of enamelled copper wire wound around a small former. Put a load on the output so that the meter shows a full-scale deflection. Close the switch. If the current displayed is exactly half of what it was, if not, switch off, remove some wire to lower the reading or add some wire to raise the reading and repeat the test until exactly half the current is displayed. The lower the value of the shunt resistor, the more current flows through it and the less through the meter, which then gives a lower reading.

Please note: it is very important to have a fuse or circuit breaker in the power being delivered to your test circuit. Any error in building the prototype can cause a major current to be drawn from the supply and **this can be dangerous**. Remember, you can't see the current. Even if you have a meter on the current being delivered, you may not notice the high reading. The first sign of trouble may be smoke! You can easily fry the circuit you are building if you do not have a safety cut-off, so use a fuse or other device which limits the current to twice what you are expecting the circuit to draw.

So, after all that, what equipment do you really need? You need a small soldering iron and multicore solder, a pair of long-nosed pliers and a multimeter. One other thing is some tool to cut wires and remove the insulation prior to soldering. Personal preferences vary. Some people prefer one of the many custom tools, some people use a knife, I personally use a pair of straight nail scissors. You pick whatever you are comfortable with.

Not exactly a vast array of essential equipment. The other items mentioned are not by any means essential so I suggest that you start by keeping things simple and use a minimum of gear.

If you are not familiar with electronics, I suggest that you get a copy of the Maplin catalogue, either from one of their shops or via the <http://www.maplin.co.uk> web site. Go through it carefully as it will show you what components are available, how much they cost and often, how they are used. The specifications of almost any semiconductor can be found free at <http://www.alldatasheet.co.kr> in the form of an Adobe Acrobat document.

Finally, because it is not important, all of the circuitry shown so far has indicated current flowing from the + of a battery to the - terminal. The discovery of voltage was made by Volta but he had no way of knowing which way the current was flowing, so he guessed. He had a 50 - 50 chance of getting it right but he was not lucky and got it wrong. Electrical current is actually a flow of electrons, and these flow from the battery minus to the battery plus. So, who cares? Almost nobody, as it has no practical effect on any of the circuitry. Some useful websites:

<http://www.esr.co.uk> for components

<http://www.maplin.co.uk> for components

<http://www.alldatasheet.co.kr> for semiconductor specifications

<http://www.cricklewoodelectronics.com> for components

<http://www.greenweld.co.uk> for components

The Oscilloscope.

If you do decide that you are going to research new equipment, design and possibly invent new devices, then an oscilloscope is useful. Let me stress again that this is not an essential item of equipment and most certainly is not needed until you are quite familiar with constructing prototypes. It is quite easy to misread the settings of an oscilloscope and the methods of operation take some getting used to. The low-cost book "How to Use Oscilloscopes and Other Test Equipment" by R.A. Penfold, ISBN 0 85934 212 3 might well be helpful when starting to use a 'scope.

It is possible to get an oscilloscope at reasonable cost by buying second-hand through eBay. The best scopes are 'dual trace' which means that they can display the input waveform and the output waveform on screen at the same time. This is a very useful feature, but because it is, the scope which have that facility sell at higher prices.

The higher the frequency which the scope can handle, the more useful it is, but again, the higher the selling price. Not all scopes are supplied with (the essential) 'test probes', so it might be necessary to buy them separately if the seller wants to keep his. Getting the manual for the scope is also a decided plus. A low cost scope might look like this:



Measuring Magnetic Field Strength.

People who experiment with permanent magnets, can make use of an instrument which displays the strength of a magnetic field. Professionally made devices to do this tend to be well outside the purchasing power of the average experimenter who will already have spent money on materials for his prototypes. Here is a design for a simple and cheap circuit, powered by four AA dry cell batteries, and utilising a Hall-effect semiconductor as the sensor:

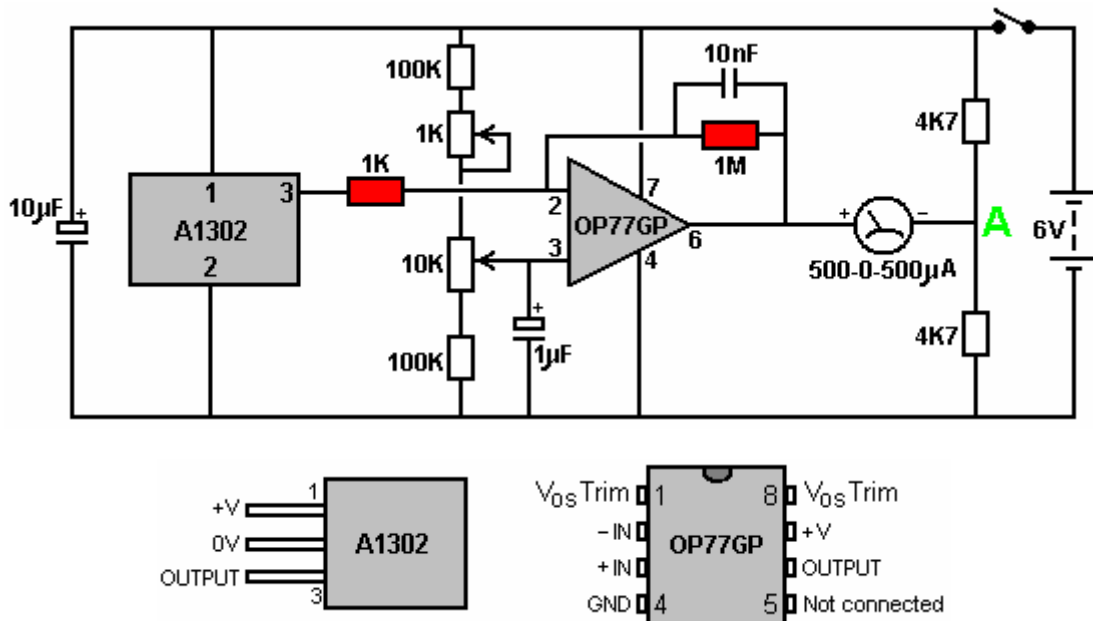

This design uses an OP77GP operational amplifier chip to boost the output signal from the A1302 chip which is a Hall-effect device. The gain of the DC-connected operational amplifier is set by the ratio of the 1K and 1M fixed resistors shown shaded in the circuit diagram, giving a gain of 1,000.

The circuit operation is simple. The six-volt battery charges the 10 microfarad capacitor which helps iron out any supply line fluctuations caused by varying current draw by the circuit. The 10K variable resistor is used to set the

output meter display to zero when the Hall-effect device is not near any magnet. The 1K variable resistor is there to make fine tuning adjustments easier.

When the A1302 chip encounters a magnetic field, the voltage on it's output pin 3 changes. This change is magnified a thousand times by the OP77GP amplifier. It's output on pin 6 is connected to one side of the display meter and the other side of the meter is connected to point "A". The voltage on point "A" is about half the battery voltage. It would be exactly half the voltage if the two 4.7K resistors were exactly the same value. This is rather unlikely as there is a manufacturing tolerance, typically around 10% of the nominal value of the resistor. The exact value of the voltage on point "A" is matched by the OP77GP tuning and so the meter reads zero until a magnetic field is encountered. When that happens, the meter deflection is directly proportional to the strength of the magnetic field.

The Weird Stuff.

You don't need to know the following information, so please feel free to skip it and move on to something else.

The presentation shown above is based on the conventional view of electronics and electrical power as taught in schools and colleges. This information and concepts works well for designing and building circuits, but that does not mean that it is wholly correct. Unfortunately, the world is not as simple as is generally made out.

For example, it is said that current is a flow of electrons passing through the wires of a circuit at the speed of light. While it is true that some electrons do actually flow through the metal of the wires, the small percentage of electrons which actually do that, do it quite slowly as they have to negotiate their way through the lattice of the molecules of metal making up the body of the wires.

In spite of this, when the On/Off switch of a circuit is flipped on, the circuit powers up immediately, no matter how long the wires are. The reason for this is that electrical current flows along the wires at very high speed indeed, but it flows rapidly **along** the outside of the wires, not rapidly **through** the wires. One thousandth of a second after switching on a circuit, the electrons flowing through the wires have hardly got started, while the current flowing along the outside of the wires has gone all around the circuit and back:



The above sketch does not show the proportions correctly, as the current flow spiralling along the outside of the wire should be hundreds of thousands of times longer than shown, which is not practical in a diagram.

The actual path taken by current flow makes the surface of the wire of particular importance, and the insulation material is also of great importance. In years gone by, wire manufacturers used to anneal (cool down) copper wires in air. This created a layer of cupric oxide on the outer surface of copper wires, and that layer gave the wire different characteristics than copper wire has today. William Barbat in his patent application claims that the cupric oxide layer can be utilised in making devices with greater power output than the power input from the user.

Unfortunately, the world is not quite as simple as that, as power flowing in a circuit has at least two components. The electrical current which we measure with ammeters is as described above and is sometimes referred to as "hot" electricity as when it flows through components, it tends to heat them up. But there is another component referred to as "cold" electricity, so named because it tends to cool components down when it flows through them. For example, if the output wires of Floyd Sweet's VTA device were short circuited together, frost would form on the device due to the heavy flow of "cold" electricity, and getting a "shock" from it could give you frostbite instead of a burn.

"Cold" electricity is not something new, it has always been there as it is just one aspect of "electricity". It has not been investigated much by conventional science because none of the instruments used to measure "hot" electricity, react to "cold" electricity at all. (Actually, "hot" electricity, "cold" electricity and magnetism are all features of a single entity which should really be called "electromagnetism").

Now the spooky bit: "cold" electricity does not flow along or through the wire at all. Instead, it flows in the space around the wire, possibly riding on the magnetic field caused by the "hot" current. Thomas Henry Moray is famous for building a device which captured "cold" electricity and produced a massive power output capable of powering a whole host of ordinary electrical pieces of equipment. In his many public demonstrations before he was intimidated into silence and his equipment smashed, he invited members of the audience to bring a piece of ordinary glass with them. Then, when his circuit was powering a row of lights, he would cut one of the wires and

insert the piece of glass between the cut ends of the wires. This had no noticeable effect on his circuit, with the power flowing happily through the glass and on through his circuit, powering the lights just as before. That does not happen with "hot" electricity, but as the "cold" electricity is not flowing through or along the surface of the wire, a break in the wire is not a major obstacle to it.

We still do not know very much about "cold" electricity. Edwin Gray snr. demonstrated light bulbs powered by "cold" electricity being submerged in water. Not only did the bulbs continue to operate unaffected by the water, but Edwin often put his hand in the water along with the lit bulb, suffering no ill effects from doing so. Neither of those two effects are possible with conventional electricity, so please **don't** try them to check it out.

Another interesting item is the water-powered car system produced by an American man Nathren Armour. His system, (among other things) involves feeding extra electrical power to the spark plugs. One thing which has always puzzled him is that the engine will not run with just one wire going to the spark plug cap. He has to have a second wire running from his extra power supply to the body of the plug where it screws into the engine block. Take that wire away and the engine stops. Put it back again and the engine runs. But according to conventional electrics, that wire cannot possibly be needed, because the engine block is grounded and the power supply output is grounded, so in theory, there is no voltage difference between the ends of the wire, therefore no current can flow along the wire, hence the wire is not needed and has no function. Well, that is true for "hot" electricity, but it seems possible that the Nathren Armour system is using "cold" electricity as well as "hot" electricity and the "cold" electricity needs the extra wire as a flow guide to the spark plug.

Enough about that for now. Let's go one step further into the "weirdness" of the actual world. If, three hundred years ago, you had described X-rays, gamma rays, nuclear energy and TV signals to the average well-educated person, you would have run a considerable risk of being locked up as being mad. If you do it today, your listener would probably just be bored as he already knows all this and accepts it as a matter of fact (which it is). Please bear that in mind when you read the following information. If it seems strange and far-fetched, that is only because conventional science today is lagging badly behind and still teaching things which have been conclusively proven to be wrong decades ago.

If you lived in a desert and every day a company drove in with a lorry-load of sand and sold it to you for a large amount of money, what would you think about that? Not a very good deal for you, is it? What's that you say, you would never do that? But you already do, because you don't realise that the sand is all around you ready for the taking at next to no cost at all. Several people have tried to publicise the fact, but the sand company has immediately silenced them by one means or another. The company does not want to lose the business of selling you the sand and definitely doesn't want you to start picking it up for yourself for free.

Well... to be perfectly fair, it is not actually sand, it is energy, and it is all around us, free for the taking. Sound a bit like X-rays did three hundred years ago? Doesn't mean that it is not true. It is perfectly true. The design of all computers made today is based on the equations of Quantum Mechanics, and while those equations are not yet perfect, they are easily good enough for practical purposes. The snag is that the world seen at the level of the quantum is not much like the world we think that we see around us and which we think that we understand fully. Examining the world at the quantum level shows that we live in a seething mass of incredible energy. Einstein is famous for stating that Mass equals a very large amount of Energy, a fact that is shown clearly when an atomic bomb is detonated. Put in different words, a small amount of matter is the equivalent of a very large amount of energy. Actually, Energy and Matter are two different aspects of a single thing (which could reasonably be called "Mass-Energy").

At the quantum level, it can be seen that particles of matter pop into existence and drop out again into energy on a continuous basis, everywhere in the whole of the universe. The whole universe is seething with energy. That energy doesn't bother us any more than water bothers a fish, as we evolved in this sea of energy and we just don't notice it. It doesn't harm us, but if we wanted, and knew how, we could use as much of that energy as we wanted for ever and ever. The amount of that energy is unbelievable. It has been calculated that one cubic centimetre anywhere in the universe contains enough energy to create all of the matter we can see in the whole of the universe. Think how many cubic centimetres there are in the Earth ... the Solar System ... our Galaxy ... If every person on Earth were to run their vehicles, power their homes, fly their planes, etc. etc. for the next million years, it would not make the slightest dent in the energy contained in one cubic millimetre of the universe. This is not a theory, it is a fact. (Would you like to buy a big pile of sand? - I've got a load just over here...). This big energy field has gone under different names over the years. A popular name at the present time is the "Zero-Point Energy Field" and it is responsible for everything that happens in the universe. It powers life itself. It balances out in equilibrium everywhere, which is one reason which makes it hard to realise that it is all around us.

Tom Beardon is an American man with very considerable abilities and considerable in-depth knowledge of how the world actually operates. His statements are generally based on laboratory-proven criteria backed up by his high level of mathematical skills which give him an additional grasp of things. He explains how electricity actually works in circuits, and it is nothing like the system taught in schools and colleges. We think that when we attach a

battery to an electrical circuit, the battery forces a current through the wires of the circuit. Sorry Chief - it is actually nothing like that at all. The power in the circuit comes directly from the Zero-Point Energy Field and has very little to do with the battery at all. We tend to think of "using up" power, but that is just not possible. Energy cannot be destroyed or "used up" the most you can do to it is to change it from one form to another. It will perform "work" (power equipment, generate heat, generate cold...) when it changes from one form to another, but if you reverse the process and convert it back to it's original form, it will perform another lot of "work" during the conversion and end up back in exactly the same state as it started out from, in spite of having performed two lots of "work" during the operation.

A battery does **not** provide energy to power a circuit. Instead, what happens is that the chemical action inside the battery causes negative charges to gather at the "minus" terminal of the battery and positive charges to gather together at the "plus" terminal of the battery. These two close-together "poles" of the battery are called a "dipole" (two opposite poles near each other) and they have an effect on the Zero-Point Energy Field which is everywhere. The "Plus" pole of the battery causes a massive cluster of Zero-Point Energy Field negative charges to cluster around it. In the same way, the "Minus" pole of the battery causes a massive gathering of ZPE ("Zero-Point Energy") positive charges to gather around it. Not only do these charges gather around the poles of the battery, but an imbalance in the energy field is created and the ZPE charges continue to arrive at the poles and they radiate out in every direction in a continuous stream of incredible energy.

So, there is your shiny new battery sitting there, not connected to anything and yet it causes massive energy streams to radiate out from its terminals in every direction. We don't notice it, because the energy flows freely through us and we can't feel it and none of our conventional instruments, such as voltmeters, ammeters, oscilloscopes, etc. react to it at all.

The situation changes immediately if we connect a circuit to the battery. The circuit provides a flow path for the ZPE energy to flow along, and a significant amount of energy flows near the wires of the circuit, actually powering the circuit for a split second until it reaches the battery "pole" at the far end of the circuit. When it gets there it promptly wipes out the pole, destroying it completely. The ZPE field calms down and the energy flow ceases. But our trusty battery immediately does it all again, using it's chemical energy to create the "dipole" once more, and the imbalance of the ZPE field starts again. It is because the battery has to use it's chemical energy all the time, creating and re-creating, and re-creating it's "dipole" that it runs down and eventually ceases to be able to create the dipole any more - result: no more power in the circuit.

Sorry to spoil the illusion, but the battery never did power the circuit itself, it merely acted as channelling device for the Zero-Point Energy Field. In passing, Direct Current ("DC") is actually not a continuous current at all, but instead it is a stream of DC pulses at an incredibly high frequency - way higher than we can measure at present. The speed of the pulses is so great that it looks continuous to us, a bit like the individual still pictures which are the frames of a movie, appear to be a moving image to us if they are played one after the other at a rate of 25 per second - it looks like continuous movement to us, but in reality, it is a rapid series of still pictures.

The way that a battery "dipole" works on the Zero-Point Energy Field is rather like the way that a magnifying glass acts on sunlight. The rays of the sun get concentrated into a point, focused by the lens. You can start a fire with the lens, and it would be easy to think that the lens started the fire, when in actual fact, it is the rays of the sun that started the fire and the lens just influenced a local area of the large "field" of sunlight, raising the temperature at just one point.

While we tend to think of a "dipole" being generated by a battery, the same effect is also created by a magnet, whether an electromagnet or a permanent magnet - remember that electricity and magnetism are two faces of the same entity. It is possible, but not easy, to capture the energy streaming out from the interference with the ZPE field caused by the poles of a magnet. For example, Hans Coler managed to do this with a completely passive device which, when set up correctly, could produce electrical power, hour after hour from apparently "nothing" (well, actually, the ZPE field). Roy Meyers also did it with his patented array of magnets and zinc plates - completely passive, with no moving parts at all, no battery and no circuitry.

Patrick Kelly

<http://www.free-energy-info.tuks.nl/>

Chapter 13: Doubtful Devices

This chapter covers a number of devices which either are unlikely to work, or which have too little practical information available to assist replication attempts. This selection, is of course, a matter of opinion.

Paul Baumann's "Thestatika" Machine.

This device is a perfect example of a free-energy device as it powers itself and provides kilowatts of excess mains electrical power. It is in this section, not because its operation is "doubtful" in any way, but because the design has never been fully disclosed. It was developed by the late Paul Baumann who was part of a Swiss commune which is not willing to explain its operation. This "Thestatika" or "Testatika" machine works beautifully and has a very high quality of workmanship. It has two electrostatic discs which are initially rotated by hand and which then continue to rotate driven by the power produced by the device.

There are various ideas as to how the device operates. The Swiss commune no longer shows this device to people as they have the theory that "mankind" is not ready to have, or use free-energy. They have always refused to show what is inside the large cylinders mounted on each side of the device. D. A. Kelly's 1991 document provides some very perceptive comments on this device. He says:

The "Swiss M-L Converter" is a fully symmetrical, influence-type energy converter which is essentially based on the Wimshurst electrostatic generator with its twin counter-rotating discs where metallic foil sectors generate and carry small charges of electricity to be stored in matched capacitors. In Wimshurst units, diagonal neutralising brushes on each opposite disc distribute the correct charges to the sectors as they revolve, but in the M-L converter this is carried out by a crystal diode which has a higher efficiency.

Two brushes collect the accumulating charges and conduct them to the storage capacitor located at the top of this device. The device has two horseshoe magnets with matched coils and a hollow cylindrical magnet as part of the diode function, and two Leyden jars which apparently serve as the final capacitor function for the converter. The use of top grade components such as gold-plated contacts, control electrodes and dual capacitor stages, insure much higher conversion efficiencies than those available with a Wimshurst machine. The details of the operating prototype are:

1. Efficiency: The unit is started by hand and no other input power is required.
2. Constant power output: 300 volts at 10 amps = 3 kilowatts.
3. Dimensions: 43.31" (1100 mm) wide, 23.62" (600 mm) tall, 17.72" (450 mm) deep.
4. Weight: 44 lbs (20 Kg).
5. Operating speed: 60 rpm. (low speed - one revolution per second).

The twin discs are made of acrylic (plastic) and the metallic segments are steel, which causes the Searle Effect with electromagnetic conversion made at the rim of the discs through passive electromagnets. This is an ideal converter since both high voltage AC and moderate AC amperage can be generated simultaneously via two separate electrical circuits from the discs. The conventional conductive brushes pick off the high voltage AC while the rim electromagnet coils produce useful amperage. When permanent horseshoe magnets with coils are used, then the output power is enhanced to a considerable extent as shown by the above output specifications.

The self-propulsion after hand-starting the discs is achieved through the adoption of the Poggendorff principle (a German scientist of the 1870s) in which slanted conductive brushes produce self-rotation in electrostatic motors (not generators).

The special crystal diode module probably provides the dual functions of frequency regulation and capacitance amplifier - to the two Leyden jars - as part of the electrical resonance circuit, since it is connected with the horseshoe magnet coils.

This device is comprised of three separate electrical circuits:

1. The high voltage AC output from the twin electrostatic discs.
2. A moderate AC amperage circuit provided by the dual horseshoe magnet coils (Searle Effect) as the plus and minus discs pass by them. (Pulsed DC output at 50 Hz).
3. A resonant circuit in which the horseshoe magnet coils are connected to the diode capacitor so that frequency regulation is assured. The diode capacitor is then connected to the Leyden jar, transmitter unit.

The major physical principles involved in this outstanding composite unit are:

1. Electrostatic conversion using twin discs for positive output from one and negative output from the other.
2. The evidence of the Searle Effect from the use of multiple, identical steel segments inducing and EMF in electromagnets at the rim of the discs.
3. The Ecklin principle is also in evidence, since the steel segments pass by permanent horseshoe magnets, as in Ecklin's S.A.G. units.
4. The Poggendorff self-rotating electrostatic motor principle as described above.
5. The crystal capacitance function of the crystal diode module. The full operation of this unique component with its hollow cylindrical permanent magnet, is a composite component with the dual functions of distributing the correct charges to the sectors, and maintaining the output frequency at the desired value.

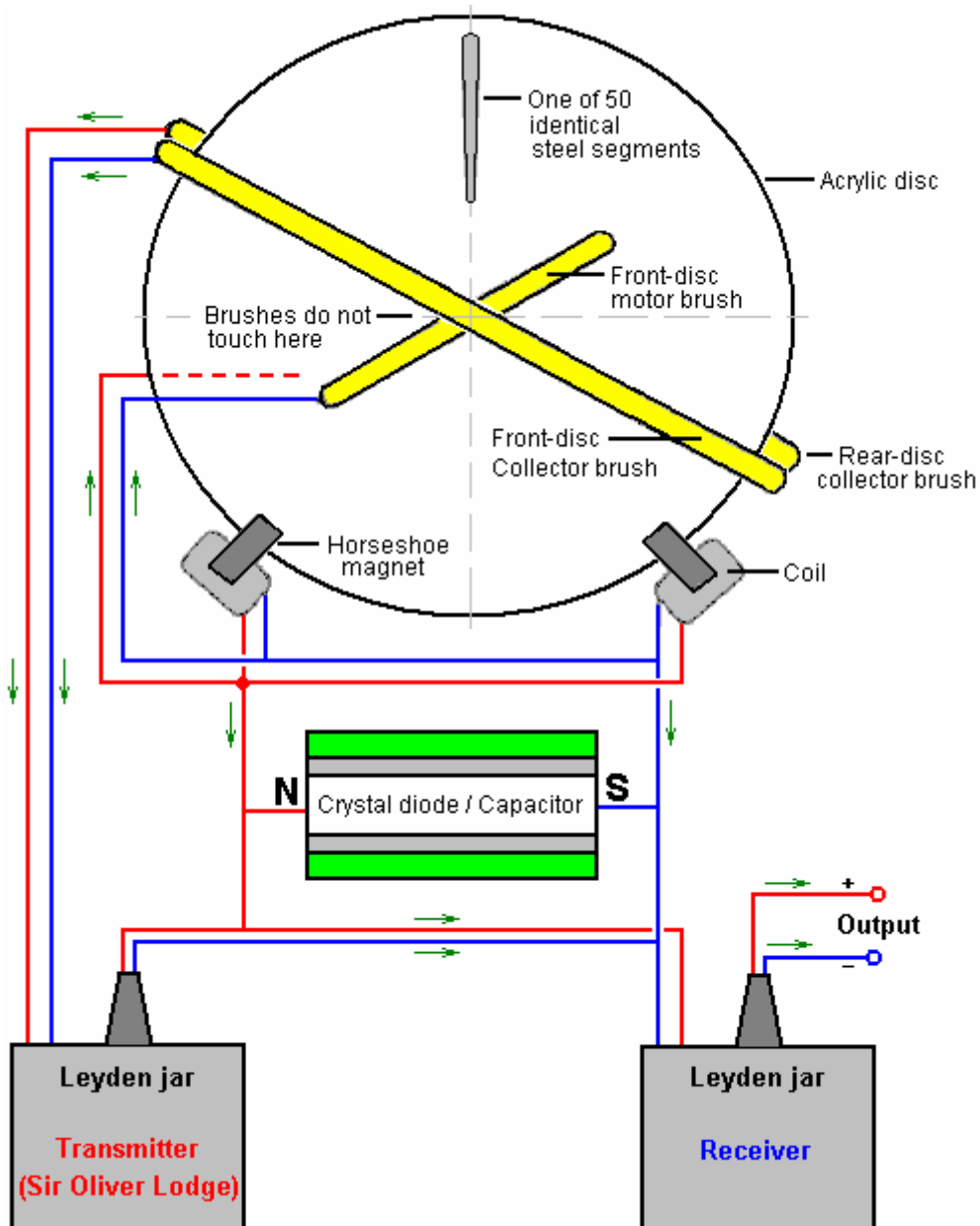

The M-L Converter is completely symmetrical with two acrylic discs, a light metal lattice, insulated copper wires, a secret crystal-diode rectifier, and gold-plated electrical connections. These machines have been developed over a period of twenty years.

In electrostatic generators, the air molecules between the two acrylic discs which counter-rotate closely side by side, become electrically activated by friction. This causes the discs to be continually charged until a flashover equalises the charge on them. To limit the voltage to the desired amount, the positively charged

particles on one of the discs and the negatively charged particles on the other disc are each extracted by means of separately adjustable lattice-electrodes, and are fed into a Leyden jar which collects the energy. The speed of the discs which have 50 lattice electrodes, is 60 rpm which produces a 50 Hz pulsed DC output. This speed is synchronised by magnetic impulses.

The unit is hand started by revolving the two discs in opposite directions until the Converter is charged up enough to synchronise itself and continues to rotate smoothly and noiselessly without any external source of input power. A centrally mounted disc of about 4" (100 mm) in diameter glimmers with all the colours of the rainbow. After a few seconds the Leyden jars are ready for operation and 300 volts DC with a current of 10 amps can be drawn from the device for any desired length of time. On many occasions, demonstrations have been made of the power available from the device. Heating elements, lights and hand power tools can be run from the device.

This suggested explanation of the M-L Converter contains a number of very interesting points. It has seemed mysterious that the electrostatic discs continued to rotate on their own without any visible motor driving them. Mr Kelly, who has seen the device and its operation, suggests that there are sloping brushes pressing against the front and rear faces of the twin electrostatic discs and that these are supplied with electrical current from the horseshoe magnet coils and that acts as a motor which drives the discs onwards once they have been started. He also suggests that the fifty steel segments per second which pass between the poles of the horseshoe magnets cause a rapidly fluctuating magnetic field through the magnet coils, which makes them operate as an Ecklin electrical generator, as described elsewhere in this eBook.

Mr D. A. Kelly also suggests that the two cylinders seen on the M-L Converter, are Leyden jar capacitors and that they work together as described by Sir Oliver Lodge (whose book is on this website). This is a very interesting suggestion, but it does not explain why the people in the Swiss commune refuse point-blank to let anyone see what is inside those cylinders.

There is a video produced by Don Kelly (presumably, a different person) which puts forward another theory of operation. He suggests that each of the cylinders contains a bi-filar coil on a barium ferrite magnet:

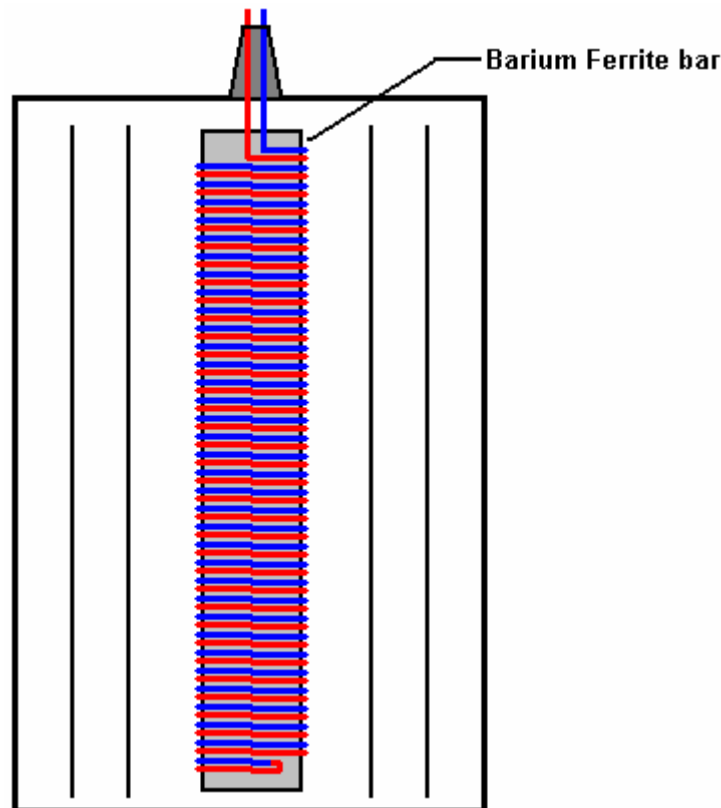

However, he describes the barium ferrite magnet as being the same type as used in radio receivers, and they are standard "ferrite rods" which are not permanent magnets as far as I am aware. Don suggests that the output from the high-voltage electrostatic discs gets fed directly to these coils and then on via a series connection to the coils around the horseshoe magnets. He envisages the bi-filar coil amplifying the current and the electrostatic discs being rotated by a standard low-voltage DC motor.

Another possibility is that the jars also contain a spark gap and surrounding copper pick-up shells and as the machine operates silently, the jars have a vacuum inside them. That would provide silent operation and explain why the people in the commune could not open them for inspection. It seems very clear that we just don't know exactly how this device operates.

One very interesting fact which has been reported by the Swiss group is that if a series of copper, aluminium and Perspex sheets are placed in a magnetic field, they generate a high voltage. This is worth investigating. It is not clear if the magnetic field should be constant or oscillating. The sequence of plates is said to be: cpacpacpacpa ("c" being copper, "p" being 'Perspex' (acrylic or 'Plexiglas') and "a" being aluminium).

The following set-up might be worth investigating:

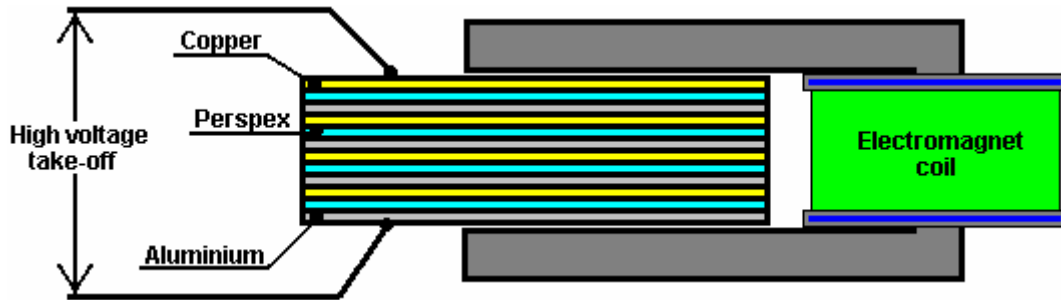

There is good information on the Testatika at <http://peswiki.com/index.php/PowerPedia:Testatika> but unfortunately, the bottom line is that nobody knows how to replicate Paul Baumann's excellent machine.

If you wish to understand the operation of electrostatic discs, then the McGraw-Hill book "Homemade Lightning" by R.A. Ford (ISBN 0-07-021528-6) gives full details of Wimshurst machines and plans for constructing your own, improved version. Ready-built Wimshurst machines are available from the web site: <http://scientificsonline.com/product.asp?pn=3070070&bhcd2=1154180654>

The Homopolar or "N-Machine".

This device was the brainchild of Michael Faraday in 1831 and has an intriguing method of operation and a remarkably large output.



The principle of operation is incredibly simple:

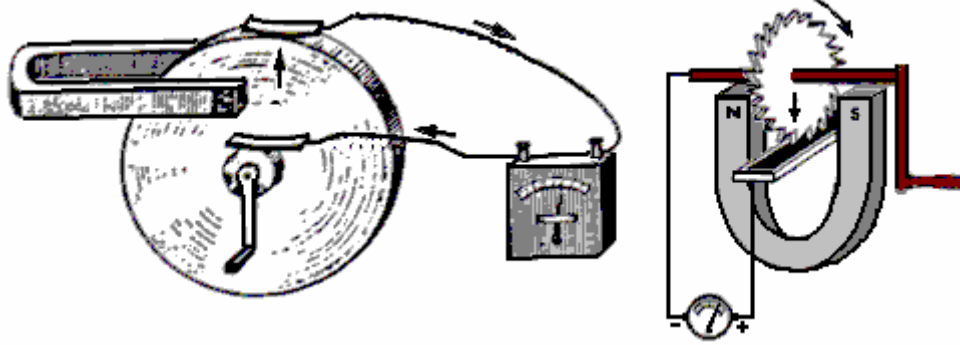

If a copper disc is rotated in a magnetic field, then power is developed between the shaft and the outer edge (or any intermediate position). It was then found that the device will still operate even if the magnet is attached to the copper disc and rotates with it - not something which is intuitively obvious. The power output is tremendous with the capability of extracting 1000 Amps but at a low voltage of less than 1 Volt. The power take-off can be from one face of the disc near the shaft rather than having to have a copper shaft integral with the copper disc. This device also works with a magnet just attached to the copper disc and rotating with it.

This looks like a very viable starting point to develop a device which can run itself and provide useful additional output, since a motor to rotate the disc will not require anything remotely like 1000A to drive it. The snag is, it is very difficult to provide reliable sliding contacts capable of handling large currents for extended periods of time. The second picture above shows the disc with its outer edge immersed in a bath of mercury. This is sufficient for a brief demonstration at low power but not realistic for a serious working device.

It might just be possible to get a reasonable working device by accepting that the current output is not going to be anything like 1000A. Long-life brushes could be made from solid copper bar and spring-loaded against the copper disc in matching pairs so that the brush thrusts oppose each other and so do not generate a sideways load. These could be made in multiple sets for each disc, say four or eight per disc, so that the effective electrical resistance between the brushes and the disc is reduced and the possible current draw increased.

Similar multiple brushes could be applied to the central shaft cylinder. Multiple discs could then be mounted on a non-conducting, non-magnetic shaft and their brushes wired in series as shown, to raise the output voltage:

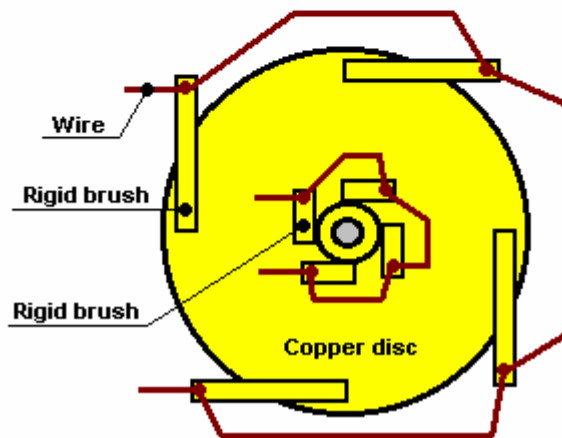
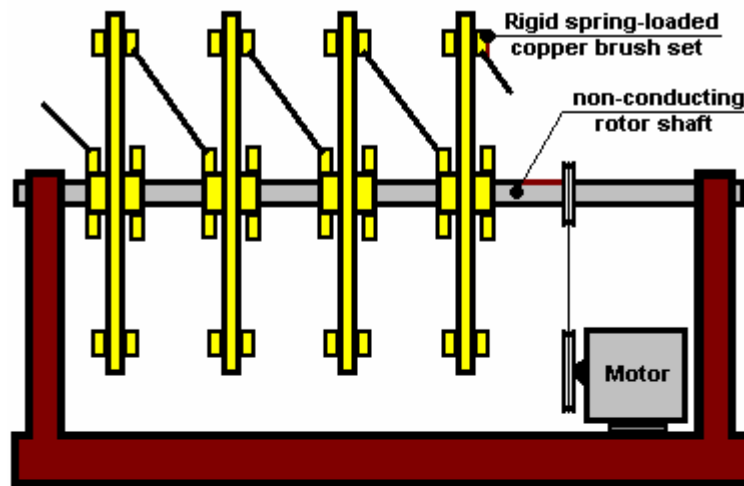

However, when this is done, the brush drag is a serious problem. In 1987, three of the Borderlands Science team, Michael Know, Peter Lindemann, and Chris Carson experimented with this design and found that a much more satisfactory version could be produced. Their version produces sawtooth AC instead of DC and so the output could be fed directly into a step-up transformer. Their design has four ferrite magnets glued between two metal discs, and for additional mechanical strength, copper wire wound around the outer edges of the magnets in order to prevent magnets flying outwards if the glue bond should fail. Their arrangement is like this:

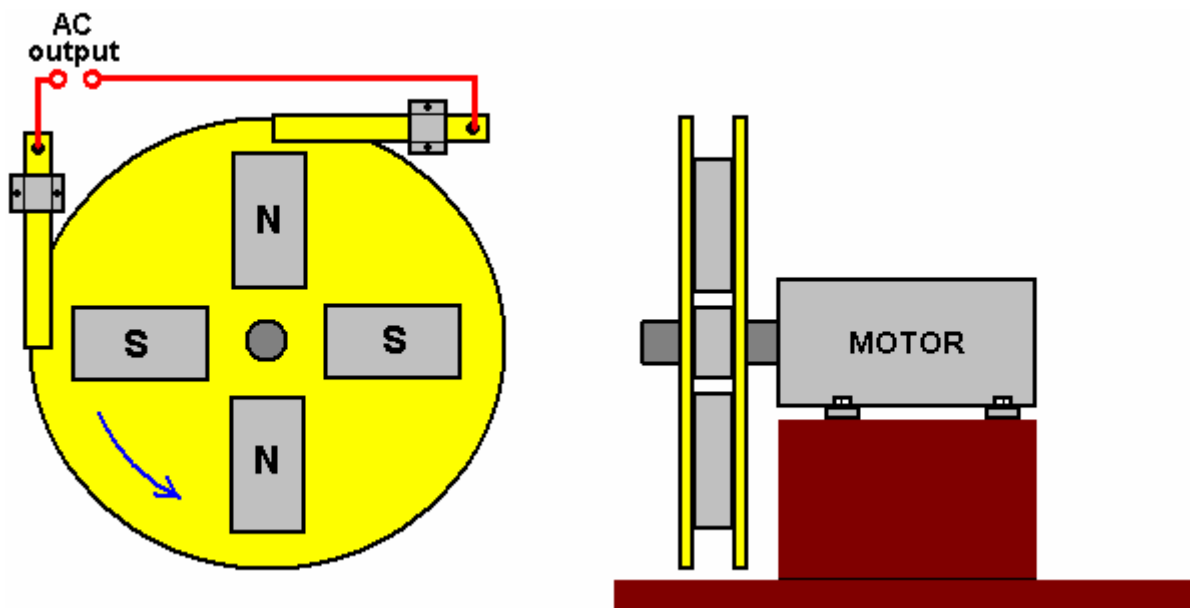

This appears to contradict the "laws" of conventional electricity as there is a very low resistance short-circuit directly across the brushes which pick up the AC voltage output. The output current from a small prototype was estimated at 100 amps. The frequency of the AC is directly proportional to the shaft speed of the motor, **but** the output voltage was almost independent of the shaft speed of the motor, increasing only very slightly with much greater speed. It was also found that putting the brushes at 90 degrees apart on the metal shaft of the motor gave the same output in spite of the contacts nearly touching each other. This design appears to have considerable potential for construction in a larger size and further investigation.

While the operation of these devices looks impossible at first glance, it needs to be understood that copper has some very unusual characteristics when interacting with magnetic fields. This is explained in the web site <http://magnetism.vfedtec.com/SpinningCylinder.htm> where it can be seen that a spinning copper cylinder exerts a large sideways force on a permanent magnet placed near it. This does not happen with spinning cylinders made from other metals.

Paramahansa Tewari received an Indian patent (397/Bom/94) in 1994 for a COP=2.5 version, details of which can be seen at <http://www.rexresearch.com/tewari/tewari.htm>.

The 'Romag' and 'Mini-Romag' Generators.

These generators have been displayed on the internet for some considerable time now. They can be found on the Jean-Louis Naudin website:

<http://jnaudin.free.fr/html/mromag.htm>

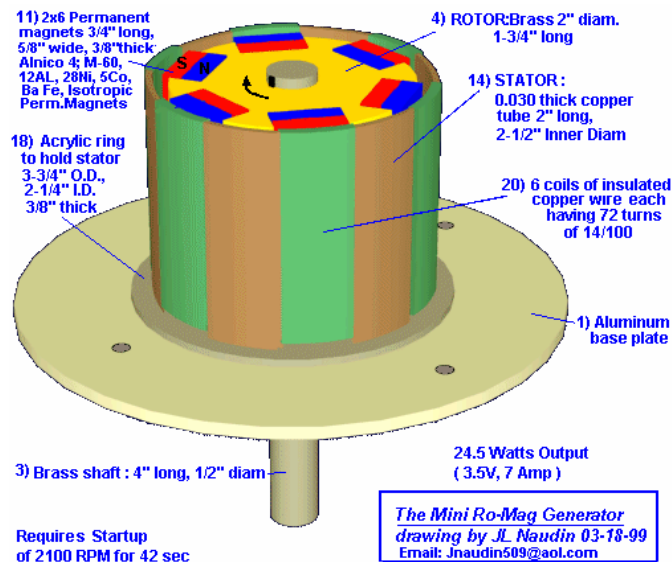

The Mini Romag generator from Magnetic Energy uses the principle of moving magnetic flow named "the magnetic current" for generating electrical power. According to Magnetic Energy this generator is able to produce 3.5 volts, 7A DC (24 Watts) of free electricity plus sufficient power to sustain itself.

This generator needs to be started by using an external motor to rotate it at 2,100 rpm for some 42 seconds. After this, the energy flow is established in the Romag generator and the external motor can be removed and the free electrical energy output can be used.

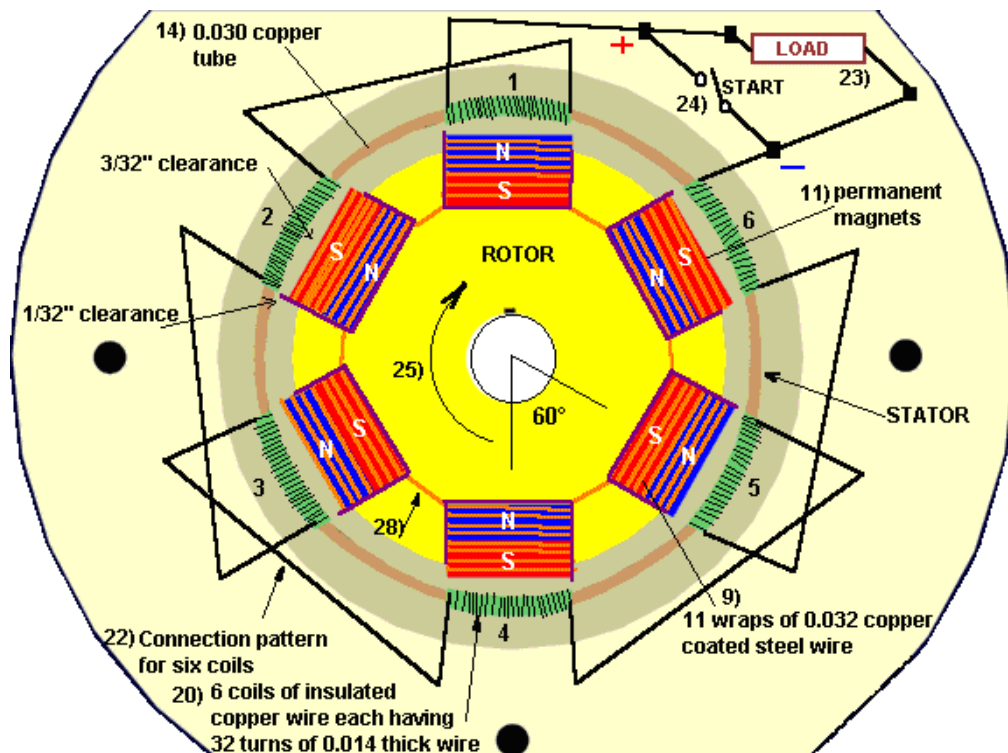

The starting procedure generates magnetic energy within the six coils of copper wire, the copper tube supporting these coils and the copper coated steel wires wrapped around the magnets. This charging is accomplished while the six coil connection wires, (shown as 22 in the above drawing), are making contact and setting up their alternating magnetic poles. After the 42 second start-up time one of these coil connection wires is opened by switch (24 above) leaving the working load in its place. The load (23 above) can draw 7 amps. As current is drawn from the six coils, it sets up magnetic poles which react with the rotor magnets maintaining the rotation. The main shaft is rotated by the 12 permanent magnets as they attract and build a release field. Then the driver unit (hand crank or motor) is disconnected allowing the unit to continue rotating with the load being the **activating** driving force.

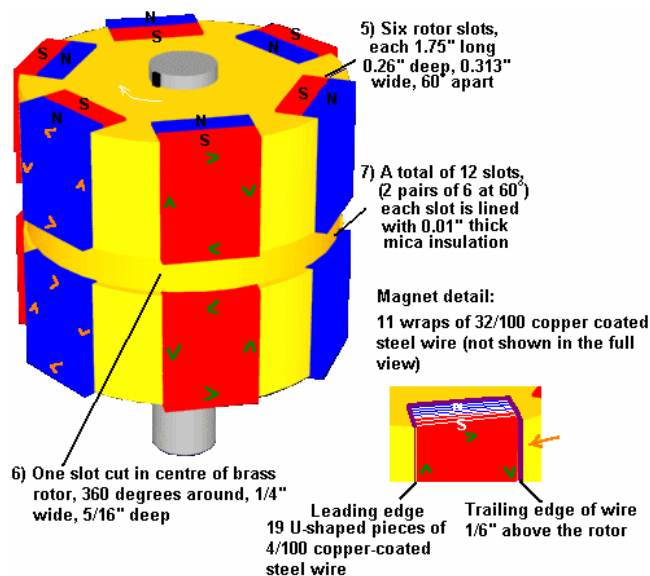

Construction:

If you decide to attempt to build one of these units we suggest using the stated materials:

1. Aluminium Base Plate
2. Sleeve Bearing of oil impregnated brass, 1" long, 0.5" inside diameter.
3. Brass Shaft, 4" long, 0.5" outside diameter
4. Rotor, brass 1.75" long, 2" diameter,
5. Six rotor slots, each 1.75" long, 0.26" deep, 0.72" wide. These slots are spaced exactly 60 degrees apart.

6. One slot cut in centre of Brass Rotor, 360 degrees around, 0.25" wide by 0.313" deep.
7. 12 slots (produced from the six slots when the 360 degree cut is made). Each slot is lined with mica insulation, 0.01" thick.
8. A total of 228 pieces of U-shaped copper coated steel wires, 0.04" thick. Each slot (7 above) has 19 pieces of these wires fitted into the Mica, thus these wires do not contact the Brass rotor. The leading edge of these wires is flush with the Rotor's outer surface and the trailing edge protrudes 1/8" above the Rotor's outer diameter.
9. Each of the 12 magnets receives eleven complete turns of 0.032" thick copper coated steel wire. These 11 turns or 'wraps' accumulate to 3/8" wide and the same pattern is placed around all 12 magnets. When placed into the bent wires (8 above), they form a snug fit making firm contact.
10. Twelve pieces of mylar insulation, 0.005" thick, are inserted into the cores of the wires (9 above).
11. The twelve permanent magnets, insulated with the mylar, must not contact wires of 9). These magnets measure 3/4" long, 5/8" wide, 3/8" thick and are made of a special composition and strength. Alnico 4, M-60; 12 AL, 28 Ni, 5 Cobalt Fe, Isotropic permanent magnet material cooled in magnetic field, Cast 9100 TS. 450 Brin, 2.2 Peak energy product. When inserted in the rotor the outer faces of these 12 magnets are not to be machined to a radius. The centre of these magnets pass the centre of the coils with 3/32" clearance. The edges, where the wires are wrapped, pass 1/32" away from the coils. This 'changing magnet spacing' aids in not only the release cycle but also contributes to rotational movement. (Sharp magnet edges which are facing the coils are to be sanded to a small smooth radius.)
12. Make sure that the magnets are placed in the Rotor with the polarity shown in the diagram.
13. The 12 magnet wire wraps are divided into two sections; 6 upper and 6 lower. There are no connections between these sections. The magnetic flow direction between the upper 6 wraps and the lower 6 wraps is attained by the 'flow direction'. The wires are wrapped around the magnet starting at the top 'north' half and then after 11 complete turns the wire exits at the lower 'south' half. As this wire then goes to the next magnet it arrives at an attract wire which is its 'north' side. Thus all wires get interconnected from south to north magnet half or north to south magnet half. The actual connections should be crimped copper clips (**not** solder) with insulation tubing to prevent contact to the Rotor body.
14. A 0.03" thick copper tube (stiff material) 2" long by 2½" inside diameter.
15. Six slots are cut at the top of tube #14. These slots are 5/8" wide by 1/32" deep spaced at 60 degrees apart.
16. Six slots are cut at the bottom of tube #14. These slots are 5/8" wide by 5/16" deep and in line with the upper slots #15.
17. There are six copper tube mounting points.
18. An acrylic ring is used to hold Part #14, measuring 3.75" outer diameter and 2.25" inner diameter, 3/8" thick, bolted directly to Part #1. This ring has a 0.03" wide groove cut 0.25" deep to allow the six copper tube mounting points to be inserted (part 17).
19. Plastic insulation paper, 0.002" thick, is to be placed around the inside and outside of Part #14.
20. There are six coils of insulated copper wire, each coil having 72 turns of .014 thick wire. Each coil is wound with two layers, the bottom layer completely fills the 5/8" wide slot with 45 turns and the top layer spans 5/16" wide with 27 turns. To be sure each coil has the exact wire length of 72 turns, a sample length wire is wrapped then unwound to serve as a template for six lengths. A suggested coil winding method is to fill a small spool with one length then by holding the copper tube at the lower extension, then start at the plus wire in Figure 2 and temporarily secure this wire to the outer surface of the tube.
21. Next, place the pre-measured spool of wire inside the tube, wrapping down and around the outside advancing clockwise until the 5/8" slot is filled with 45 turns. Then, return this wire back across the top of the coil for 15/32" and winding in the same direction again advance clockwise placing the second layer spanned for 5/16" with 27 turns. This method should have the second layer perfectly centered above the first layer. After winding this coil, repeat the process, filling the small spool with another length of pre-measured wire. A very important magnetic response happens as all six coils have their second layers spaced in this way.
22. Item 22 above shows the connection pattern for six coils. When the unit is driven at start-up (hand crank) for 42 seconds at 2100 RPM, all six jumper wires must be together which means the plus wire goes to the minus wire connected by the start switch. After 42 seconds the load is added to the circuit and the start switch is opened. To double check your connections between the coils, note that the finish wire of coil #1 goes to the finish wire of coil #2, which is top layer to top layer. This pattern then has start of coil 2 (bottom layer) going to start of coil 3 (also bottom layer). When the copper tube with the coils is placed around the rotor, the distance from any magnet to any coil must be identical. If it measures different, acrylic holding shapes can be bolted to the aluminium base, protruding upward, and thus push the copper tube in the direction needed to maintain the spacing as stated.
23. Wires to load.
24. Wires to start switch.
25. Rotational direction which is clock—wise when viewing from top down.
26. Acrylic dome for protection against elements.

27. Coating of clear acrylic to solidify rotor. **Do not use standard motor varnish.** Pre-heat the rotor and then dip it into heated liquid acrylic. After removal from dip tank, hand rotate until the acrylic hardens, then balance rotor. For balancing procedure, either add brass weights or remove brass as needed by drilling small holes into rotor on its heavy side.
28. Insulation tubing on all connections.
29. Shaft for start purposes and speed testing (if desired).

The reason that this generator is included in this chapter is because the construction is quite complex. Also, the plans have been around for several years without my being aware of anyone constructing or operating one of these units other than J.L. Naudin.

Cold Fusion.

Cold fusion was initially accepted with great excitement. It then appeared to be discredited, primarily as a matter of fear of losing the funding for the decades old "hot" fusion research. At the present time, there are some two hundred labs. which have confirmed the findings and so there is no doubt as to the reality of the system. In essence, it is said that nuclear fusion can take place at room temperature, under certain conditions. However, a commercial working device is now reaching the market with details at Sterling Allan's website: [http://peswiki.com/index.php/Directory:Andrea A. Rossi Cold Fusion Generator](http://peswiki.com/index.php/Directory:Andrea_A._Rossi_Cold_Fusion_Generator).

If you want the background details of cold fusion history, then there are several web sites which follow the progress in this field, including "Cold Fusion Times" at <http://world.std.com/~mica/cft.html> where considerable detail is available. However, although a cold fusion generator is unlikely to be something which you can knock together in your back yard, the process is edging steadily towards general use. In 2012, the Rossi "Ecat" cold fusion generator is expected to launch. The web site <http://ecat.com/> is already taking orders and the home unit producing 10 kilowatts, is expected to sell for US \$500 and have an annual running cost of just \$20.

The Frolov / Moller Atomic Hydrogen Generator.

One already successful experiment has been shown at the J.L. Naudin website where many successful tests were performed. Alexander Frolov remarks that due to the water pump being externally powered, the results shown by J.L. Naudin are not quite accurate although the error is not significant for power levels below one kilowatt, and so the performance is actually very slightly less than that reported.

This system started with William Lyne's concept which he published in his book "Occult Ether Systems" in 1997. In 1999, Nikolas Moller bought a copy of Lyne's book and drew the attention of Alexander Frolov to the idea. Alexander then worked on the idea and produced both the present theory and design. A joint project was then started between Alexander's Faraday Company Ltd. of St. Petersburg in Russia (www.faraday.ru) and Nikolas' company Spectrum Ltd.

The prototype shown in the photograph below, was then built by Alexander and passed to Nikolas where it was tested extensively. The exact process involved in the energy gain has only recently been fully disclosed in Alexander's book entitled "New Energy Sources".

The technique used involves repeatedly converting a quantity of hydrogen gas from its diatomic state (H_2 where two hydrogen atoms are bonded together to form a stable molecule), to its monatomic state H-H (where two hydrogen atoms remain as separate atoms, not closely bonded together) and back again to its original form.

No hydrogen is consumed. No additional gas is required. The gas is just converted from one state to the other, repeatedly. The problem for conventional science is that the output power measured in tests is considerably greater than the input power in carefully measured tests which were run for periods of more than half an hour each. The additional power is flowing in from the Zero-Point Energy field due to an energy extraction mechanism caused by the collision of molecules which have very different atomic weights. This is explained by Dr Frolov in his paper: <http://alexfrolov.narod.ru/mac.html> where the energy imbalance is described in detail. In it, he observes that the theory shows clearly that an input of 1,400 watts is capable of producing an output of 7,250 watts due to the impact energy imbalance between high-mass and low-mass molecules when they collide.

Here is a photograph of the development assembly built by Alexander Frolov and then used in the testing phase of the system:



Muammer Yildiz's "Ocean Star" Electrical Generator.

This is a purely mechanical device which is self-powered and which can provide electric current to drive other equipment. This device was designed and built in Turkey. It was demonstrated in Dortmund on 17th October 2005 where the demonstration was conducted by J. L. Duarte who ran an independent test and produced a report dated 17th July 2005 on behalf of the Department of Electrical Engineering, Electromechanics and Power Electronics of the Eindhoven Technische Universiteit. Muammer has obtained Patent Application WO2004091083 for his design. The demonstration was of his portable unit which outputs some 12 volts DC:



During the demonstration was used to light a car light bulb very brightly:



Muammer has also produced a larger version capable of powering a house:



The demonstration unit was started using a 16 AHr battery for a few seconds. Once the unit reaches its running speed, it becomes self-powered and capable of delivering substantial electrical power and the starting battery is then disconnected. In theory, no mechanical system can produce 100% efficiency, let

alone more than 100%. This system where a motor spins several generators, is very much like the Raoul Hatem system described in Chapter 2.

The report by Dr. J. L. Duarte on the smaller unit provides the following information:

This technical note aims at describing a test which I personally conducted in Izmir, Turkey on 17th July 2005. The purpose of the experiment was to check the energy balance with respect to input and output of an apparatus which was the embodiment of the invention described in the international patent WO 2004/091083 A1 (shown below).

The apparatus was confined inside a metallic box sized 550 x 380 x 270 mm, weighing some 20 Kg, and I was allowed to inspect everything outside this box. However, in order to protect the core ideas of the invention, I was not supposed to check all the details of the internal parts. According to the inventor, the apparatus is predominantly a mechanical system, without any kind of energy storage inside the box (such as batteries, accumulators, flywheels, combustion motors, chemical or radioactive reactions). I believe the intentions of the inventor to be in good faith.

The experimental set-up was quite simple, as shown schematically in **Fig.1**. It consisted of placing the box with unknown contents, from which DC voltages and currents were expected to be generated, on a table in the middle of the room. A cable with two terminal contacts was run from the box and instruments were placed between the box and the load, which was a standard DC/AC inverter driving an incandescent lamp. The output power from the box was measured before the load connection as shown here:

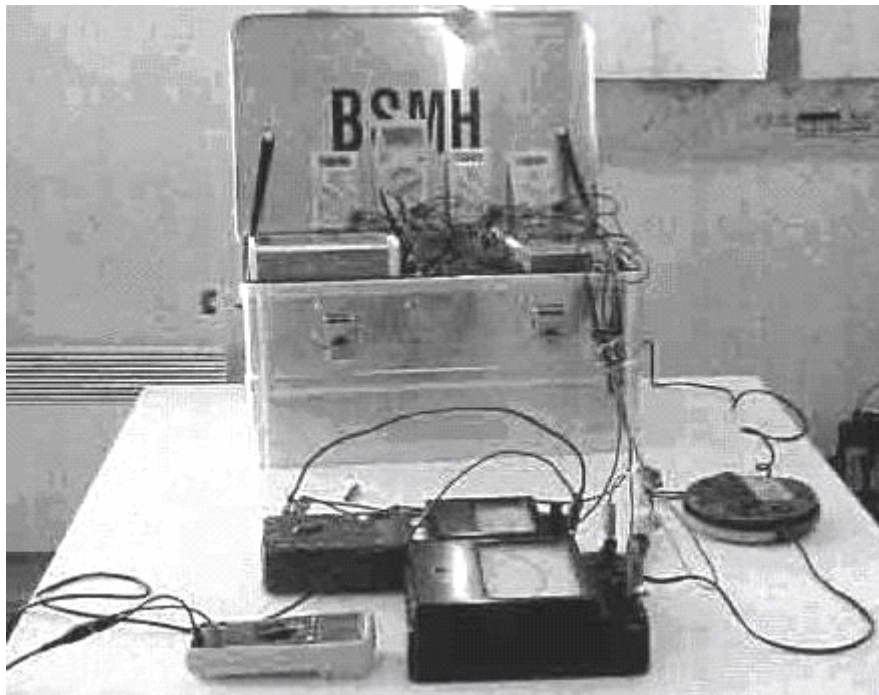

The circuit connection method used is shown here:

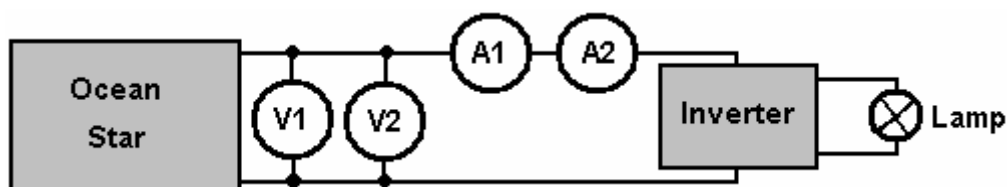

After a short start procedure, the metallic box and the load were both fully isolated from the environment, ensuring that there was no physical contact or connection to external power sources such as the public electric mains supply, at any time during the whole duration of the measurements. As the start-up energy input to the apparatus was quite modest, the main issue was then to measure the delivered energy output.

I had prepared the power measurements with care, by using reliable instruments which I personally brought with me from my own University laboratory. In order to measure the DC voltage directly out of the positive

and negative terminals, I used two different voltmeters connected in parallel. One voltmeter was an analogue type, constructed with permanent magnets and wires, while the other was a digital voltmeter. To measure the DC current I used two ammeters in series, one analogue and one digital. If electromagnetic waves should interfere with the measurements, then they would disturb one or other instrument, but not all four pieces at the same time and in the same way.

Before starting the test, no audible sound was being produced by the apparatus. The measured voltage and current at the terminals were zero. So, as far as I could observe, the apparatus was completely at rest.

The start-up procedure consisted of connecting a small 12V DC lead-acid battery to two contact points inside the box for a few seconds. I checked the time using my own watch and it was more than 5 seconds but less than 10 seconds. I consider it reasonable to consider the time to have been 8 seconds. After that time, no energy input was connected to the box by means of cables.

Immediately after the start-up procedure, I could hear noise such as would be produced by parts rotating inside the box. The inventor said that some ten minutes should be allowed to elapse before the load was connected. During that time, both of the voltmeters showed the output voltage dropping slowly from 12.9 volts to 12.5 volts. The two voltmeters matched accurately. In the following hours, I observed and recorded by hand, the voltage and current values displayed by the instruments. The displayed values were quite stable, so I initially decided to note them at 15 minute intervals, but later on at 30 minute intervals.

From time to time, using my hands, I attempted to find a temperature gradient inside the box, but I could not detect any variation or increase in the temperature compared to the room temperature. After five hours, I took the decision to stop the measurements. The results are shown in the following table:

Time	V1 (Digital)	V2 (Analogue)	A1 (Digital)	A2 (Analogue)
0:00	12:54	12.5	2.23	2.35
0:15	12.57	12.5	2.29	2.35
0:30	12.57	12.5	2.29	2.35
0:45	12.53	12.5	2.27	2.35
1:00	12.51	12.5	2.27	2.35
1:15	12.48	12.5	2.27	2.35
1:30	12.47	12.5	2.27	2.35
2:00	12.41	12.4	2.26	2.35
2:30	12.35	12.4	2.26	2.35
3:00	12.30	12.3	2.25	2.35
3:30	12.22	12.3	2.25	2.3
4:00	12.15	12.2	2.25	2.3
4:30	12.01	12.1	2.24	2.3
5:00	12.00	12.0	2.23	2.3

As far as I am concerned, the above table of results raises serious doubts. The voltage readings are absolutely typical of an inverter powered by a lead-acid battery. I have tested many batteries in exactly the same way and the table looks 100% familiar. If the box contained a genuine self-powered generator, then I would expect the output voltage to remain constant under the constant current drain. In my opinion, it was wholly irresponsible to have stopped the test after just five hours with the output voltage falling steadily. If the output voltage had been rock steady at 12.5 volts for the whole five hours, then that would not have been quite so bad but with it going down 12.3, 12.2, 12.1, 12.0 in the last four 30-minute intervals, and with a lead-acid battery voltage of 11.5 for a fully discharged battery, it was wholly unrealistic to stop the test. A further ten hours of testing should have been undertaken.

However, early in 2010, Muammer demonstrated a permanent magnet motor/generator of his own design. That type of device is notoriously difficult to get functional, let alone producing the 250 watts of power which Muammer demonstrated at Delft University. As part of the demonstration, Muammer took the motor apart completely to show that there was no hidden power source. This shows clearly that Muammer is a man of very considerable ability, and that lends considerable credibility to his earlier device shown here. Unfortunately, the patent application is not in English and some of the terms produced by a rough translation are not at all clear. Consequently, although the design appears quite simple, it can't be rated as a design which could be confidently replicated from the information here and for that reason, the OceanStar information remains here, among the "Unlikely to Result in a Workable Device" section.

Here is the information from the Patent Application WO2004091083 although the quality of reproduction and the clarity of the wording is not particularly good:

A SYSTEM WHICH GENERATES ELECTRICAL POWER VIA AN ACCUMULATOR THAT PROVIDES THE INITIAL MOTION FOR THE SYSTEM

ABSTRACT

This is a portable system that generates electrical power via an accumulator that provides the initial motion for the system. Two batteries are used in this system and the system is kept working via the initial motion provided by these batteries. There is no need for another transformer. This device works using its own mechanism and there is no need for additional devices. In this way, a continuous electrical power generation is possible. This device can work without connecting it to a network so it is possible to use it at places where electricity does not exist. Moreover, when connected to the entry of a building, the need for a network is avoided. This system generates electrical power independent of a network.

DESCRIPTION

A system which generates electrical power via an accumulator that provides the initial motion for the system. This is a portable system that generates electrical power via an accumulator that provides the initial motion for the system. Already existing systems can generate electric power of whose duration depends on the lifetime of the battery. In these systems, the battery has to be reloaded in order to restart the system. 12V electrical power provided by the batteries used in cars is increased to 220 V via transformers.

Two accumulators are used in our invention. The system works on a continuous basis after the initial start up via these accumulators. There is no need for another transformer. Our system, which generates electrical power, does not need any other devices and it keeps on generating energy via its own mechanism. Also, the system works without connecting it to a network.

Thus, it can be used at any place where no electricity exists. Nevertheless, when this system is connected to the entry of the buildings, there is no need for an additional network. The system can produce electrical power independent of a network.

DESCRIPTION OF THE DRAWINGS

Below are the explanations of the figures that provide a better understanding about this invention.

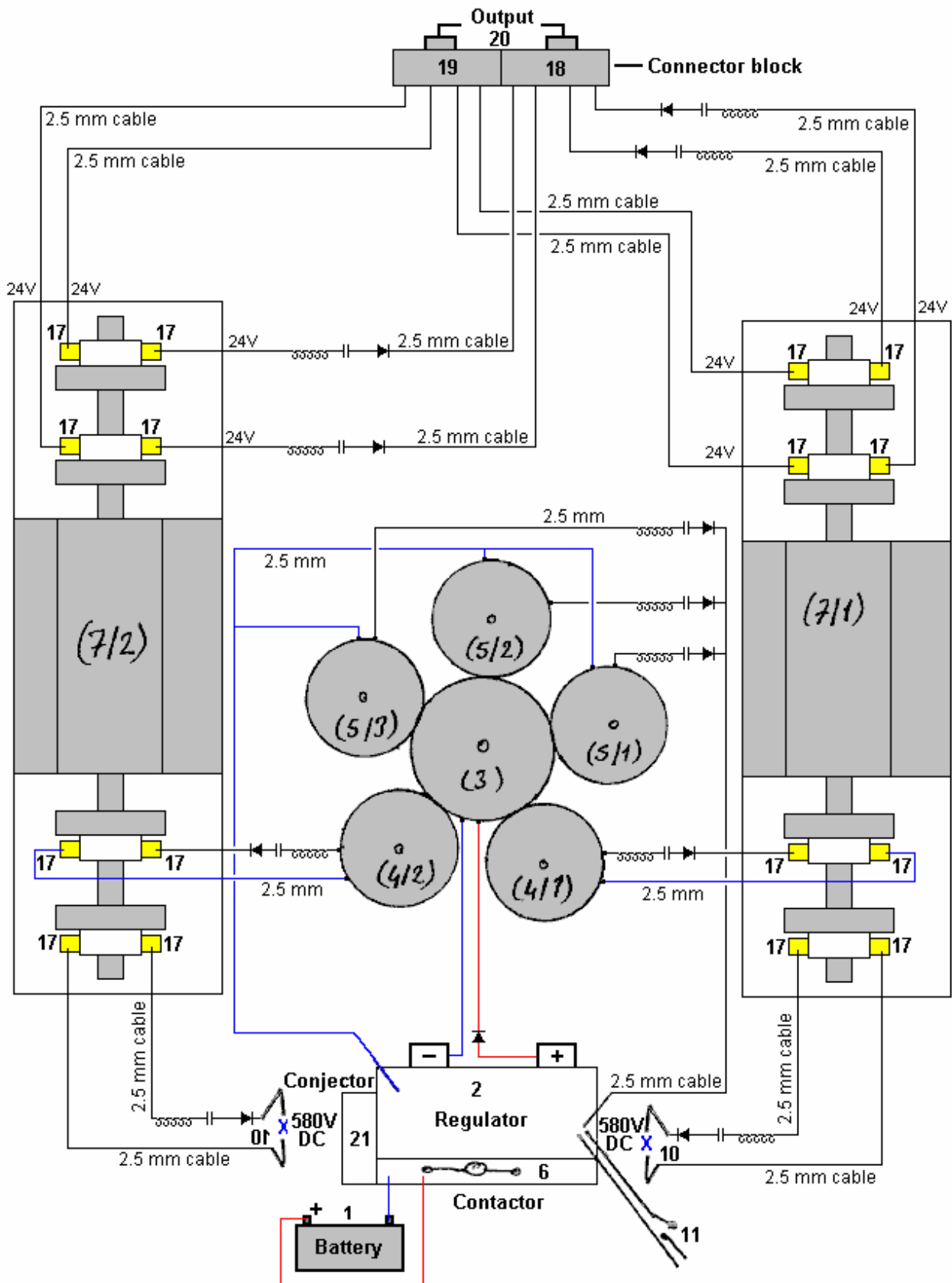

Fig.1 is a schematic view of the system.

Numbers used on the schematic:

1- Accumulator

- 2- Regulator
- 3- Big Gear 3/1-Starter dynamo
- 4- Small gear 4/1-2-Feedback dynamo
- 5- Small gear 5/1-2-3-Feedback dynamo
- 6- Contactor
- 7/1 and 7/2- Commitatris
- 8- 29 DC input
- 9- 24 DC output
- 10- 580 DC output
- 11-Switch
- 12- Shunt
- 13- Rectifier
- 14- Capacitor
- 15- 2.5 mm cable
- 16- Collector
- 17- Charcoal
- 18- Fixing clamps
- 19- Fixing clamps
- 20- Lamp
- 21- Conjector
- 22- Starter dynamo
- 23- Feedback dynamo
- 24- Alternating current dynamo
- 25- Magnetic switch
- 26- Pulley
- 27- Pulley
- 28- V pulley
- 29- 380V current output
- 30- 220 V current input

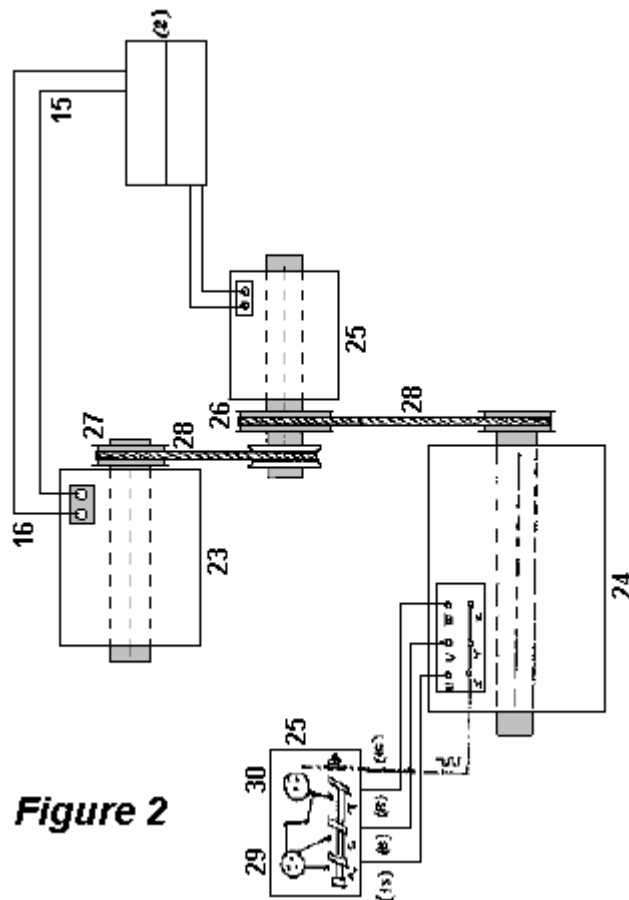

Figure 2

DESCRIPTION

This invention is a system that starts working via the motion of alternator. There exist two accumulators(1), and the first motion provided by the accumulator is carried to the regulator. Contactor (6) keeps the starter dynamo working by disconnecting the accumulator (1) once the regulator (2) is put in. The voltage coming from the accumulator (1) passes through the regulator and the start dynamo (3/1) starts working and thus the feedback alternators via the gears (4/1-2-5/1-23-3). Feedback dynamo start sending pure DC current to regulator via shunt (12), capacitor (14) and diode (13). It connects all the currents that reaches to the regulator in 4 seconds and sends to the contactor (6). Accumulator (1) is put out by this current that reaches to the regulator. This current is transformed to the started dynamo (3/1). There becomes a transformation within the system. In case of electricity shortage, it keeps on working by using the current generated by the commutatoris (7/1).

Via the starter dynamo(3/1), DC is generated in the alternators which are connected to the gears and this current is transformed to the commutatoris (7/1 and 7/2) and DC voltage is generated at commutatoris (7/1 and 7/2).

Second System: 3x24 DC voltage is transformed to the second starter dynamo (22). Once the start dynamo works (22), a feedback dynamo (23) having a pulley system and a feedback dynamo (24) generating alternating current starts working. The feedback dynamo (23) starts feeding back; the feedback dynamo (24) which generates alternating current is independently generating 6 KV, 18 Amp, 50Hz current. Moreover, first system produces 24 DC and 580 DC current on its own. The bigger the gears are, the more the generated current is.

This system, which is the subject of our invention, can be used at any place. You can use it at places where there exist no electricity, or at places such as villages, cities, buildings, greenhouses where there is no network. Moreover, network is no longer a must. Instead of a network, you can use our system. There is no need for gasoline when this system is used in vehicles.

Jesse McQueen's System.

There is a US patent which was granted to Jesse McQueen in 2006. This system looks too good to be true and, on the surface, appears impossible, even taking into account that it has been said that ordinary vehicle alternators have a Coefficient Of Performance over one (i.e. output energy is greater than the energy that the user has to put into the device to make it operate). I am not aware of anybody who has tried this system, so I have no evidence that it doesn't work - just a lack of belief in a system of this type being able to operate as described. As against that, it is not far from the proven system of Chas Campbell (chapter 4) and the US Patent office has granted this patent and they have a reputation of being highly opposed to admitting that there is any such thing as a "perpetual motion machine", which this system appears to be. So, I leave it up to you to make up your own mind, and test the system if you wish, which should be easy to do as it involves no real construction, but instead, uses off-the-shelf manufactured products which are readily available and not particularly expensive. Here is the patent:

US Patent 7,095,126

22nd August 2006

Inventor: Jesse McQueen

INTERNAL ENERGY-GENERATING POWER SOURCE

ABSTRACT

An external power source such as a battery is used to initially supply power to start an alternator and generator. Once the system has started it is not necessary for the battery to supply power to the system. The battery can then be disconnected. The alternator and electric motor work in combination to generator electrical power. The alternator supplies this electrical power to the two inverters. One inverter outputs part of it's power to the lamp, and part back to the electric motor/generator. This power is used to power the electric motor. The second inverter supplies power to the specific load devices which are connected to the system.

US Patent References:

5033565	July 1991	Abukawa et al.
5036267	July 1991	Markunas
5785136	July 1998	Falkenmayer et al.

BACKGROUND OF THE INVENTION

Electrical energy occurs naturally, but seldom in forms that can be used. For example, although the energy dissipated as lightning exceeds the world's demand for electricity by a large factor, lightning has not been put to practical use because of its unpredictability and other problems. Generally, practical electric-power-generating systems convert the mechanical energy of moving parts into electrical energy. While systems that operate without a mechanical step do exist, they are at present either excessively inefficient or expensive because of a dependence on elaborate technology. While some electric plants derive mechanical energy from moving water (hydroelectric power), the vast majority derives it from heat engines in which the working substance is steam. Roughly 89% of power in the United States is generated this way. The steam is generated with heat from combustion of fossil fuels or from nuclear fission.

In electricity, a machine is used to change mechanical energy into electrical energy. It operates on the principle of electromagnetic induction. When a conductor passes through a magnetic field, a voltage is induced across the ends of the conductor. The generator is simply a mechanical arrangement for moving the conductor and leading the current produced by the voltage to an external circuit, where it actuates devices which require electricity. In the simplest form of generator, the conductor is an open coil of wire rotating between the poles of a permanent magnet. During a single rotation, one side of the coil passes through the magnetic field first in one direction and then in the other, so that the induced current is alternating current (AC), moving first in one direction, then in the other. Each end of the coil is attached to a separate metal slip ring that rotates with the coil. Brushes that rest on the slip rings are attached to the external circuit. Thus the current flows from the coil to the slip rings, then through the brushes to the external circuit. In order to obtain direct current (DC), i.e., current that flows in only one direction, a commutator is used in place of slip rings.

A commutator is a single slip ring split into left and right halves that are insulated from each other and are attached to opposite ends of the coil. It allows current to leave the generator through the brushes in only one direction. This current pulsates, going from no flow to maximum flow and back again to no flow. A practical DC generator, with many coils and with many segments in the commutator, gives a steadier current. There are also several magnets in a practical generator. In any generator, the whole assembly carrying the coils is called the armature, or rotor, while the stationary parts constitute the stator. Except in the case of the magneto, which uses permanent magnets, AC and DC generators use electromagnets. Field current for the electromagnets is most often DC from an external source. The term dynamo is often used for the DC generator; the generator in automotive applications is usually a dynamo. An AC generator is called an alternator. To ease various construction problems, alternators have a stationary armature and rotating electromagnets. Most alternators produce a polyphase AC, a complex type of current that provides a smoother power flow than does simple AC. By far the greatest amount of electricity for industrial and civilian use comes from large AC generators driven by steam turbines.

SUMMARY OF THE INVENTION

It is an objective of the present invention to provide an energy source that generates more energy than the energy source requires in order to operate.

It is a second objective of the present invention to provide a system that uses the excess energy produced by the energy source to power other various devices.

It is a third objective of the present invention to provide an energy source for supplying power to various devices without the reliance on an external energy source for supplying power to the energy source of the present invention.

The present invention provides an energy source that is capable of producing more energy than it requires to operate. The excess energy is used to power devices. A feedback loop approach is used to channel a portion of the energy produce by the generator back to the generators power input port. This feedback loop approach enables the generator to use its own generated energy to operate. The additional energy generated by the generator is used to power other devices that can be connected to the generator.

In the method of the invention an external power source such as a battery is used to initially supply power to start an alternator and generator. Once the system has started it is not necessary for the battery to supply power to the system. The battery can then be disconnected. The alternator and electric motor work in combination to generate electrical power. The alternator supplies this electrical power to the two inverters. One inverter outputs part of its power to the lamp load device and part back to the electric motor/generator.

This power is used to power the electric motor. The second inverter supplies power to the specific load devices that are connected to the system.

DESCRIPTION OF THE DRAWINGS

Fig.1 is a configuration of an implementation of the internal power generating system of the present invention.

Fig.2 is a configuration of an alternate embodiment of the internal power generating system of the present invention.

DESCRIPTION OF THE INVENTION

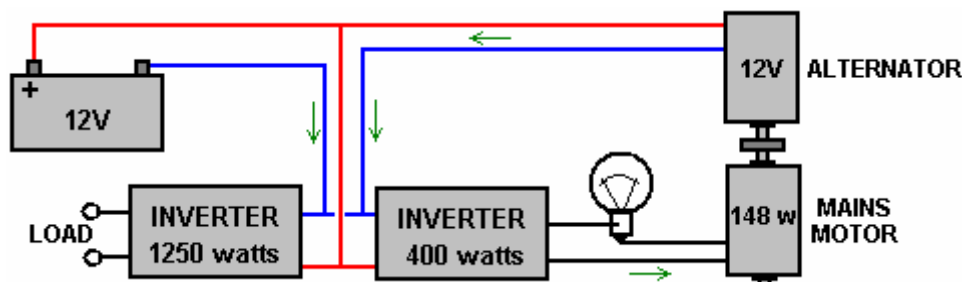
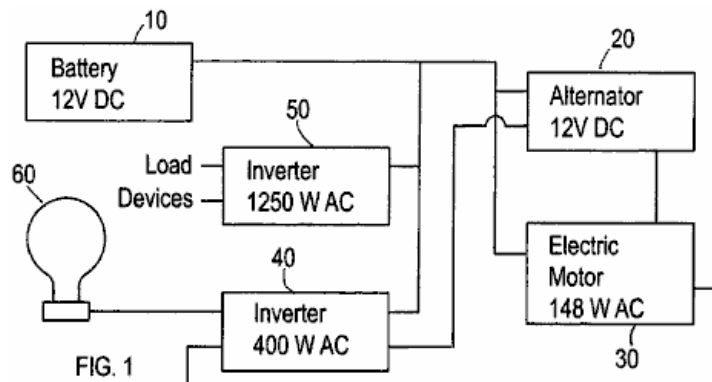

This invention is an electric power-generating device that produces several times more power than it takes to operate this system. This invention comprises a first power source that is connected to a second power source. Referring to **Fig.1**, the system of the present invention comprises a battery source **10** (12 volt DC) that connects to an electrical alternator **20**. The battery supplies the initial power to the system to initiate/start the operation of the alternator. The present invention can implement other power sources in addition to the illustrated battery to supply the initial power to the system. In the initial model of the present invention incorporated an alternator from a 1997 Isuzu Trooper. The invention incorporates an electric motor **30** (148 watt AC). The electric motor connects to an inverter **40** (400 watt AC). The system also comprises a second inverter **50**. The battery **10** also connects to both inverters **40** and **50**. Each inverter has two outputs. For the first inverter **40**, one output feeds into the electric motor **30** to provide to the motor and alternator combination. The other output feeds into a lamp device **60**. The lamp device is a 60-watt AC lamp. This lamp device alters the current travelling from the inverter **40** such that the current feeding into the electric motor **30** is not purely inductive.

Although, **Fig.1** shows a lamp device, other loads can be used to accomplish this same a task. The inverter **40** has an input from which the inverter receives power from the alternator **20**. The second inverter **50** also has an input that also receives power from the alternator.

In operation, initially, the battery **10** is used to supply power to start the alternator **20** and generator **30**. Once the system has started, it is not necessary for the battery to supply power to the system. The battery can then be disconnected. Once started, the alternator **20** and electric motor **30** work in combination to generate electrical power. The alternator supplies this electrical power to the two inverters **40** and **50**. Inverter **40** outputs part of this power to the lamp **60** and part to the electric motor **30**. This power is used to

power the electric motor. The second inverter **50** supplies power to the specific load devices which are connected to the system. These load devices can be any devices which operate by using electrical power.

The key aspect of the present invention is the loop between the alternator **20**, electric motor **30** and the first inverter **40**. A portion of the power generated by the electric motor is recycled and is used to power the electric motor. In this way the system produces the power internally that is used to power the system. This concept makes this system a self-power generating system.

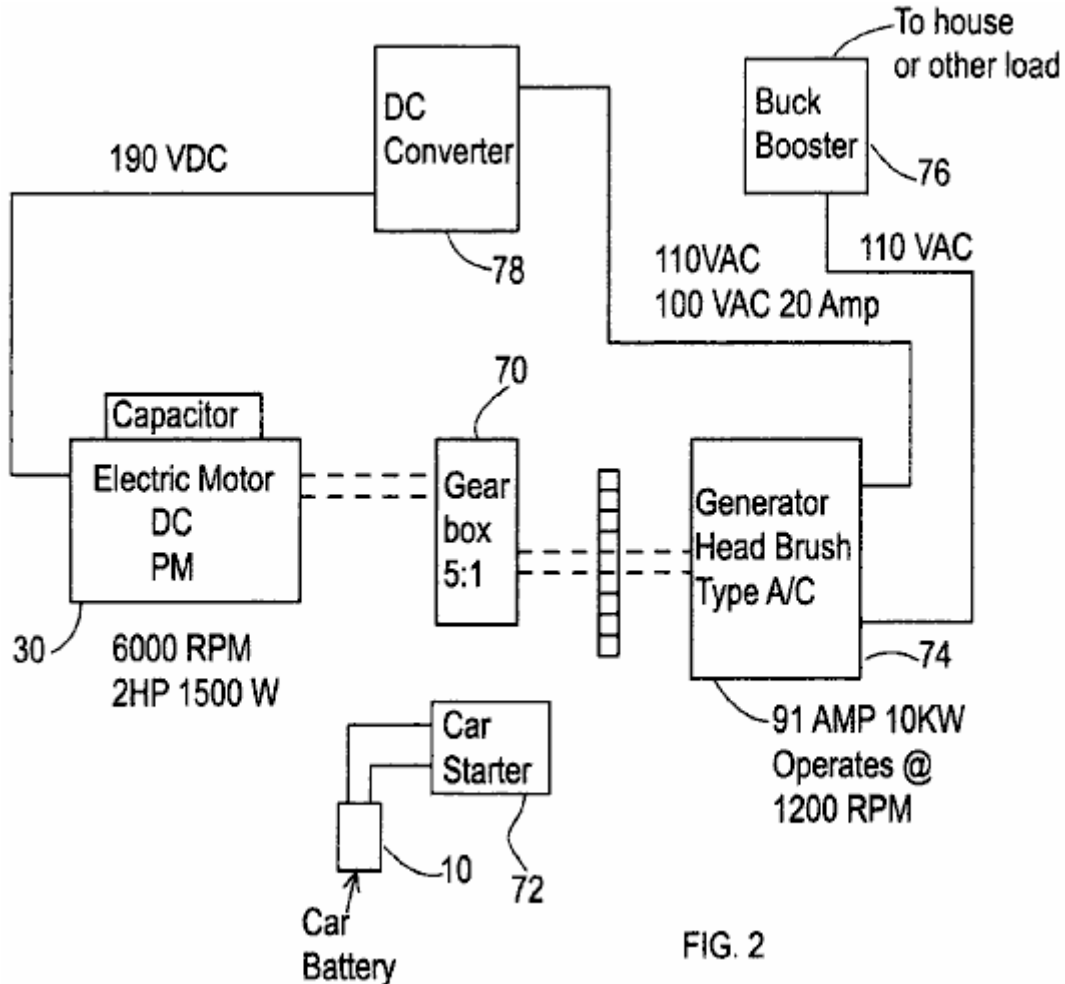

FIG. 2

Fig.2 shows an alternative embodiment of the power generating system of the present invention. This embodiment incorporates a gear box **70**, a car starter **72**, and a head brush generator **74**, and buck booster **76**. Initially, the car starter **72** works with the battery to supply power to the generator. This process is similar to the process of starting a car. The gearshift **70** increases the rpm of the generator. The Buck Booster **76** serves as the output to supply power to the various loads. This configuration also incorporates a DC converter **78**.

The "Nitro" Cell.

This document was originally produced at the request of an Australian man who said that the cell worked well for him but that he was afraid to publish the details himself. This document was prepared, approved by him and published. It proved very popular and an enthusiast group was set up to build and test this "Nitro Cell".

The results of this building and testing have been most unsatisfactory. As far as I am aware, not a single cell proved successful in powering an engine. I therefore, withdrew the document, since even though I believe it to be capable of working, the fact that many people failed to get it working indicates to me that this document should not be in a "practical" guide. I have been assured by two separate independent sources, both of which I rate as being reliable sources, that there are "hundreds" of these cells working in Australia and the USA. I have repeatedly been asked for copies of this document, so I am publishing it again, but requesting

you, the reader, to be aware that should you make one of these devices, that it is unlikely that you will get it operational. Having said that, I understand that it may work very well as a booster.

Simple arithmetic applied to the claimed performance of this device, shows that much of the claimed mileage has to have been covered without using any fuel at all. While this sounds impossible, in actual fact it is not, **but** that sort of operation comes from the Joe Cell which is notoriously difficult to get operational, requiring at least a week of fiddling around to get the metalwork of the vehicle aligned with the energy field used to provide the motive power. Also, each person acts as a "dipole" which produces an energy field around that person. Most people have a polarity which opposes the Joe Cell energy, and they will **never** get a Joe Cell to operate as they can disrupt such a cell from several paces away from it. Chapter 9, which describes the Joe Cell, includes information on how to reverse your own personal polarity, to stop blocking the cell performance.

This definitely sounds unbelievable, but as it happens to be the way that things actually are, there is little point in pretending otherwise. Personally, I never recommend anybody to build a Joe Cell for powering a vehicle, as the likelihood of success is so low. However, having said that, a friend of mine in the USA has his Joe Cell connected to his truck in "shandy" mode where the carburettor is left connected to it's normal fossil fuel supply. The vehicle is perfectly capable of drawing in fossil fuel to run the engine, but it just doesn't. His fuel consumption is literally zero and he is driving around powered solely by the energy channelled into the engine by the Joe Cell. This is most unusual, and I do not recommend you spending time and money on building such a cell. I mention these cells so that you can know all about them, but I would leave it at that.

Here is the original "D18" document, which is followed by important update information:

[A Different Fuel](#)

In the early days of heavier than air flight, observations were made and based on those observations, practical operating rules were deduced. After a time, those rules became called the "laws" of aerodynamics. These "laws" were applied to the design, building and use of aircraft and they were, and are, very useful.

One day it was observed that if you apply those laws of aerodynamics to bumble bees, then according to those laws, it was not possible for a bee to fly since there was just not enough lift generated to get the bee off the ground. But simple observation shows that bees do in fact fly and they can rise off the ground when they choose to do so.

Does that mean that the "laws" of aerodynamics are no good? Of course not, as they have been shown to be of great practical use when dealing with aircraft. What it did show was that the existing laws did not cover every instance, so research was done and the laws of aerodynamics were extended to include the equations for lift generated by turbulent flow. These show how a bee can develop enough lift to get off the ground. Do bees care about this? No, not at all, they just go on flying as before. What has changed is that the understanding of scientists and engineers has been extended to better fit the world around us.

Today, people who are trained in science and engineering are fed the idea that internal combustion engines need to consume a fossil fuel in order to operate. That is not strictly true and at the present time, engines using hydrogen gas as a fuel are becoming commonplace. Unfortunately, most of the hydrogen produced for this use, comes from fossil fuels, so these vehicles are still running on a fossil fuel, though only indirectly.

The "laws" of engineering say that it is not possible for an internal combustion engine to run without consuming some sort of fuel. Unfortunately, Josef Papp has demonstrated an internal combustion engine which has had it's intake and exhaust systems blanked off. Filled with a mixture of inert gasses, during one demonstration, that Volvo engine ran for half an hour, producing a measured 300 horsepower, and apparently consuming no fuel at all. Josef received US patent 3,680,432 for his engine and you can see a video of one of his engines running at <http://video.google.com/videoplay?docid=-2850891179207690407>. Robert Britt designed a similar sealed motor filled with a mixture of inert gasses, and he received US patent 3,977,191 for it.

Does this mean that the current laws of engineering are of no use? Certainly not, they are vital for everyday life today. What it does mean, however, is that the present laws need to be extended to include the effects shown by these engines.

Another thing widely accepted today is that an internal combustion engine can't use water as a fuel. Well.... let's leave that to one side for the moment and look at it from a slightly different angle. Engines can definitely

run using air and hydrogen as the fuel, there is no argument about that as there are many vehicle around which do just that. If you pass a current through water, the water breaks up into hydrogen gas and oxygen gas, this mixture is called "hydroxy" gas and that can most definitely be used, along with air, as the fuel for an internal combustion engine. But... this gas came from water, so is it really correct to say that water cannot be used as the fuel for an internal combustion engine?

Ah, says somebody with relief, that is not the case, because you are using water **and** electricity to get the fuel for the engine. But... the average vehicle powered by an internal combustion engine, has an alternator which produces electricity when the engine is running, so **there** is a source of electricity to do the electrolysis of the water and produce the gas to run the engine.

But the laws of engineering say that you can't get enough electricity from the alternator to produce enough gas to run the engine. Engineers will point to the work of Faraday who examined the process of electrolysis in great detail and produced the "laws" of electrolysis. These laws show that you can't get enough electrical power from an engine to make enough gas to run the engine.

Unfortunately, there have been several people who have done just that, so we have reached the point in time when these "laws" need to be extended to cover cases not covered by the work of Faraday. People have got from 300% to 1,200% of the gas output which Faraday considered to be the maximum possible. Several people have run vehicles on hydroxy gas produced by electrolysis of water using electricity generated by the vehicle's alternator. This shows clearly that it can be done, and as a consequence, the "laws" need to be extended to include the newer techniques.

Leaving that aside for the moment, there have been at least two people who have managed to power an engine with water as the only fuel, and without using electrolysis. In this instance, a fine spray of water droplets inside the cylinder is acted on by the spark, and a secondary electrical supply from an inverter boosts the spark, forming a plasma discharge. The result is a power stroke nearly as powerful as using a fossil fuel. For the moment, let us also ignore that style of operation.

This document describes another system which uses water and air as the primary fuels, but again, does not use electrolysis to generate hydroxy gas for use in the engine. Instead, the objective is to create a continuous supply of Nitrogen Hydroxide (NHO_2) for use as the fuel. This system has worked well for a number of people but there has been considerable intimidation and most of these people are very reluctant to pass the information on. This document is an attempt to present those details clearly enough to allow the system to be replicated by anyone who wishes to do so.

So, how exactly is this fuel generated? The production method is described as the fuel gas being synthesised by a mixture of stream water and rock salt (the mineral "halite") in the presence of air, being acted on by engine "vacuum", electrolysis and a strong magnetic field. This fuel is said to be more powerful than hydrogen and is a much more viable fuel source as less of it is needed to run an internal combustion engine.

This system may be used with any internal combustion engine, whether used in a vehicle or stationary when powering an electrical generator or other equipment. The additional equipment consists of one, or more, horizontal cylinders mounted near the engine. A single, horizontally mounted, cylinder can generate sufficient gas to power an internal combustion engine up to two litres in capacity. Larger engines will need two cylinders to generate enough gas for them to operate.

It must be stressed that this is **not** a hydroxy gas electrolysis cell. One test vehicle has been run on this system for a distance of 3,000 miles (4,800 kilometers) and the liquid fuel used was only 2 litres of water and 2 gallons of petrol. Two litres of water converted to hydroxy gas will definitely not power a vehicle engine for anything like 3,000 miles, so let me stress again that the fuel being generated in this cell is Nitrogen Hydroxide (NHO_2). It should be noted that if the cell described here is used as a booster for the original fossil fuel, then it will not be necessary to upgrade the engine by fitting stainless steel valves, piston rings, exhaust system, etc.

The person using this system which is shown in the following photograph, has opted for an exceptionally long generation tube attached to his stationary generator:

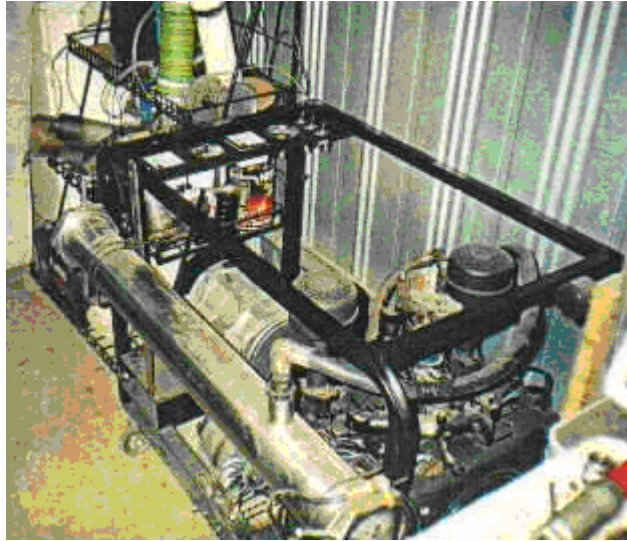

The versions of this cell design shown in the previous photograph and the following photograph, are early models which were in use before it was discovered that there was a considerable enhancement in gas production if a coil is wrapped around the cylinder.

For vehicle operation, it is more normal to have a shorter cylinder, (or pair of cylinders if the engine capacity is large) as can be seen in the following photograph of a 4-litre, 8-cylinder vehicle engine which uses this system. Engines of up to 2 litre capacity can be powered by a single horizontal cell, while two cells are used for larger engines.



The construction details are not difficult to follow and the materials needed are not particularly difficult to find nor expensive to buy. The main body of the device is constructed as shown in the following diagram. A chamber is constructed from a piece of 316L Grade (food quality) stainless steel pipe, 300 mm (12 inches) long and 100 mm (4 inches) in diameter. The length of 300 mm is chosen for convenience of fitting in the engine compartment of a vehicle. If there is plenty of room there, the length can be extended for better gas performance and water capacity. If that is done, keep the 100 mm cylinder diameter and all of the clearance dimensions mentioned below.

The chamber is sealed at each end with 12 mm (half inch) thick discs made from "Lexan" (a very strong polycarbonate resin thermoplastic). These discs have a 3 mm (1/8") deep groove cut into their inner faces. The groove is there for the cylinder to fit into when the discs are clamped in place and held by stainless steel

nuts tightened on a 10 mm (3/8") stainless steel threaded rod. To combat engine vibration, a lock nut is used to clamp the retaining nuts in place. The threaded rod also provides the contact point for the negative side of the electrical supply and a stainless steel bolt is TIG welded to the outside of the cylinder to form the connection point for the positive side of the electrical supply.

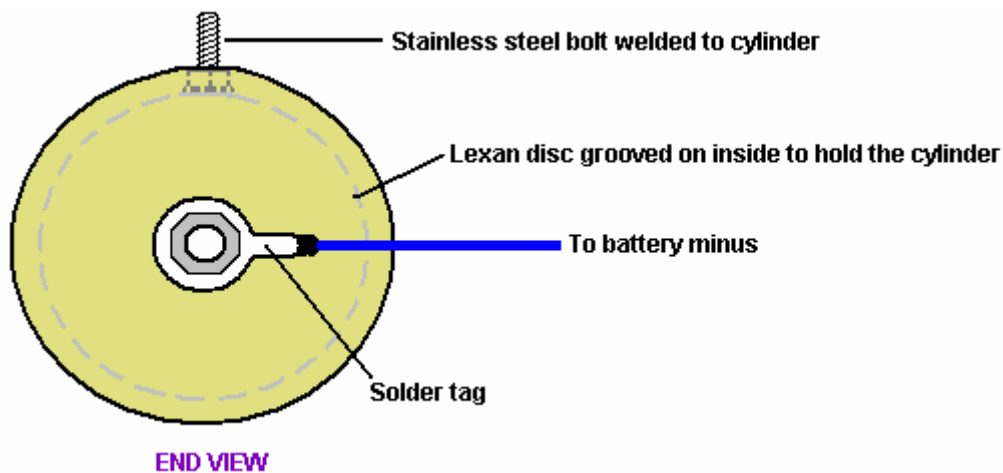
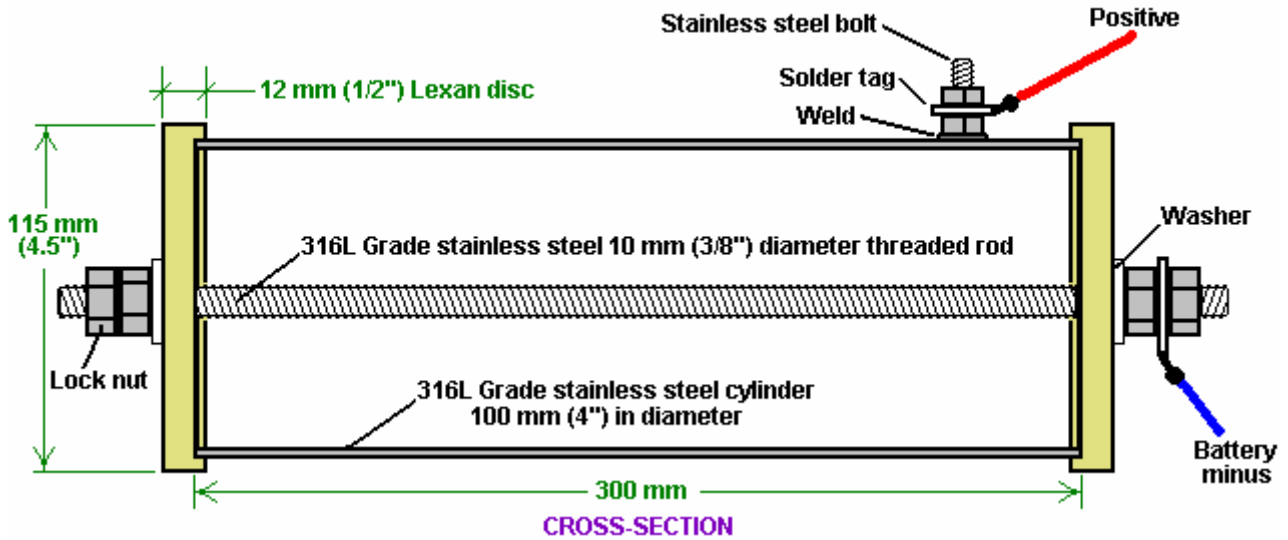

This basic container is modified in a number of ways. Firstly, a small 3 mm (1/8 inch) diameter air intake pipe is provided in one of the Lexan discs. This air intake is provided with a needle-valve which is screwed tightly shut for the early stages of testing and only eased slightly open when the engine is actually running.

Also fitted is an 12 mm (1/2") stainless steel pipe, attached to the stainless steel cylinder to form a gas supply feed to the engine. A one-way valve is placed in this pipe as the design calls for the cylinder to be maintained at a pressure which is less than the outside atmosphere. The lower the pressure inside the cell, the greater the rate of gas production. The one-way valve allows flow into the engine but blocks any flow from the engine into the cylinder. This valve is the same type as is used in the vehicle's vacuum brake booster system.

The gas outlet pipe is continued from the one-way valve using plastic tubing for a few inches. This is to prevent an electrical connection between the stainless steel cylinder which is connected to the positive side of the electrical supply, and the engine manifold which is connected to the negative side of the electrical supply. If this pipe were metal all the way, then that would create a direct electrical short-circuit. The pipe running to the engine intake manifold needs to be made of metal in the area near the engine, due to the high engine temperature, so stainless steel pipe should be used for the last part of the gas supply pipe running to the engine. The gas supply pipe fitting is made to the most central of the bungs fitted to the manifold.

For the initial testing period, a filling port with a screw cap is mounted on the top of the cylinder, in order to allow the water inside to be topped up as necessary. Later on, if long journeys are made on a regular basis,

then it is worth fitting a separate water tank, water-level sensor and water injection system using a standard vehicle windscreen washer water pump. The topping up is done with water alone as the rock salt additive does not get used in the process and so does not need to be replaced. With these additional features, the gas generation cell looks like this:

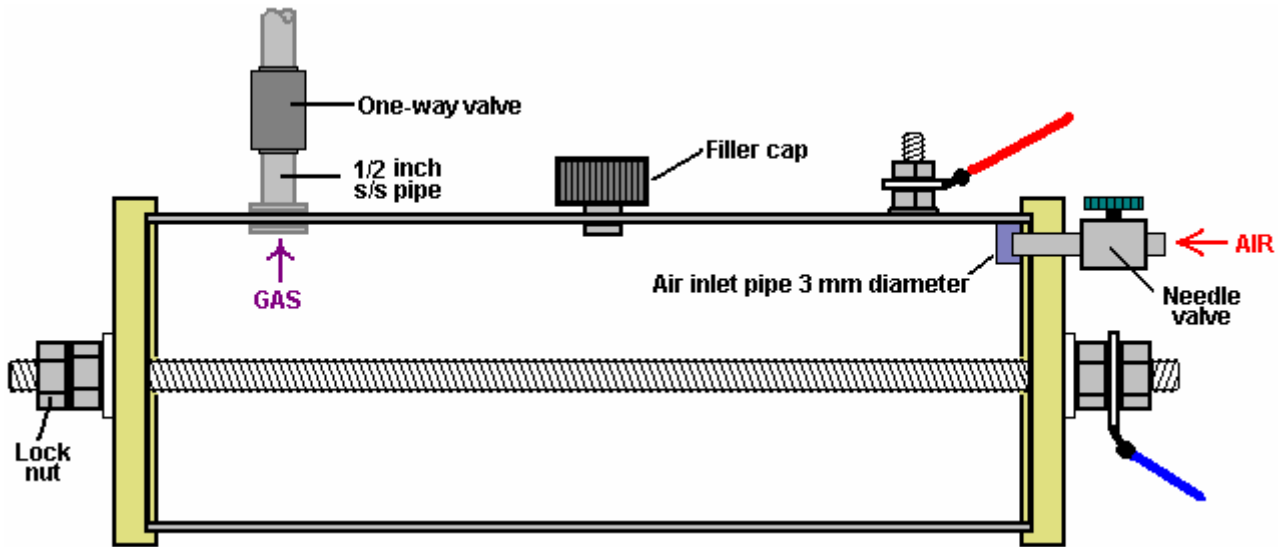

There is one further step, and that is to add an inner cylinder of 316L grade stainless steel. This cylinder is 274 mm (10.75 inches) long and 80 mm (3.15") in diameter. Both cylinders have a wall thickness of 1 mm. The inner cylinder is supported on the central threaded bar and it is clamped in place with retaining nuts. A supporting lug is created by making two cuts at each end of the cylinder, drilling a hole and then bending the lug up inside the cylinder at right angles to its axis. This needs to be done accurately, otherwise the inner cylinder will not lie parallel to the threaded rod, or alternatively, not be centred on the threaded rod. The centre of the 10 mm (3/8") hole is positioned 8 mm (5/16") in from the end of the cylinder. Two 48 mm (1.9") long cuts are made each side of the hole, positioned to be about 5 mm (3/16") clear of the hole - this measurement is not critical. This is done at each end of the cylinder and the holes are positioned exactly opposite one another, along the axis of the cylinder, as shown here:

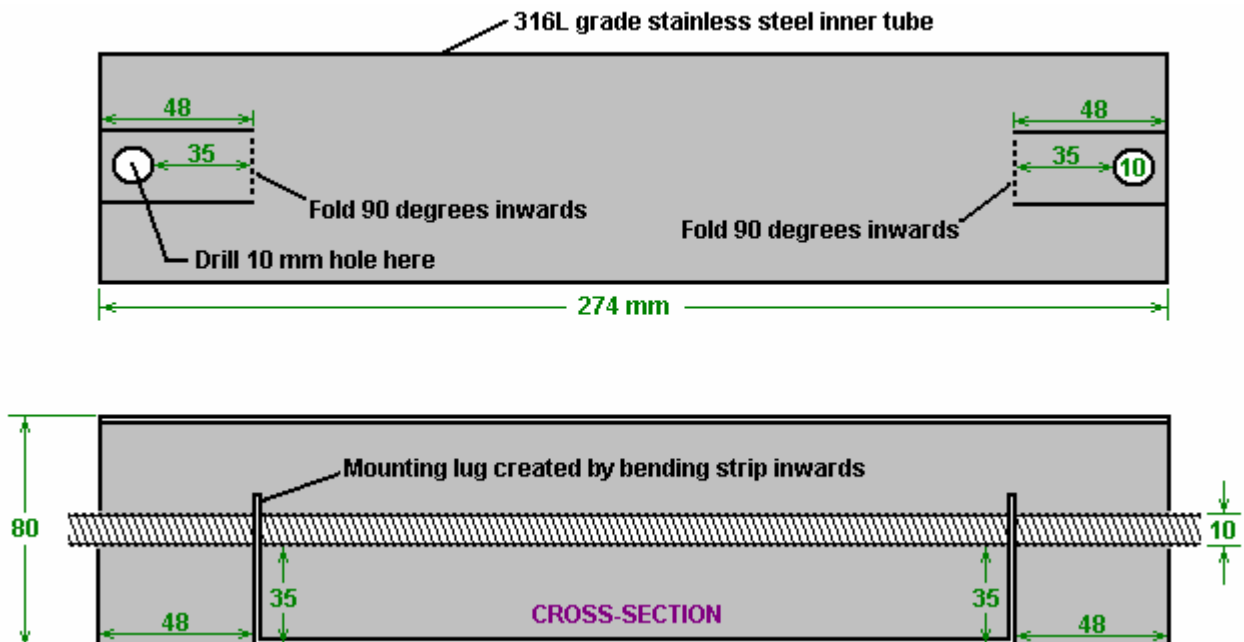

The inner cylinder is secured in position by two bolts as shown here:

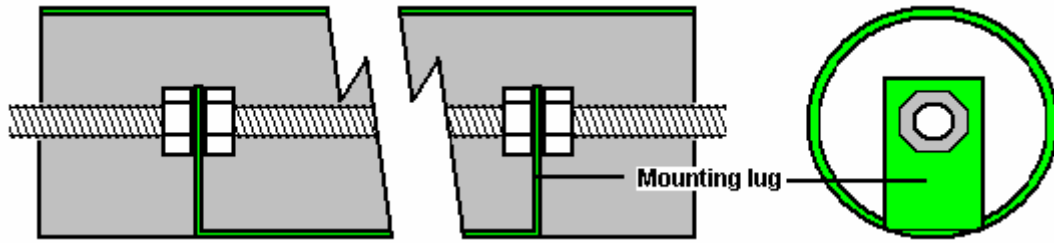

The inner nuts are manoeuvred on inside on of the lugs by hand and then the threaded rod is rotated to move one nut to the inside of the other lug, while the nearer nut is held to prevent it rotating. When the rod is positioned correctly and the inner nuts are pressed up hard against the lugs, then a box spanner is used to lock the outer nuts tightly against the lugs, forming a strong mounting lock.

The inner cylinder is inserted inside the outer cylinder, the Lexan end discs are then added and the outer lock nuts added to produce this arrangement:

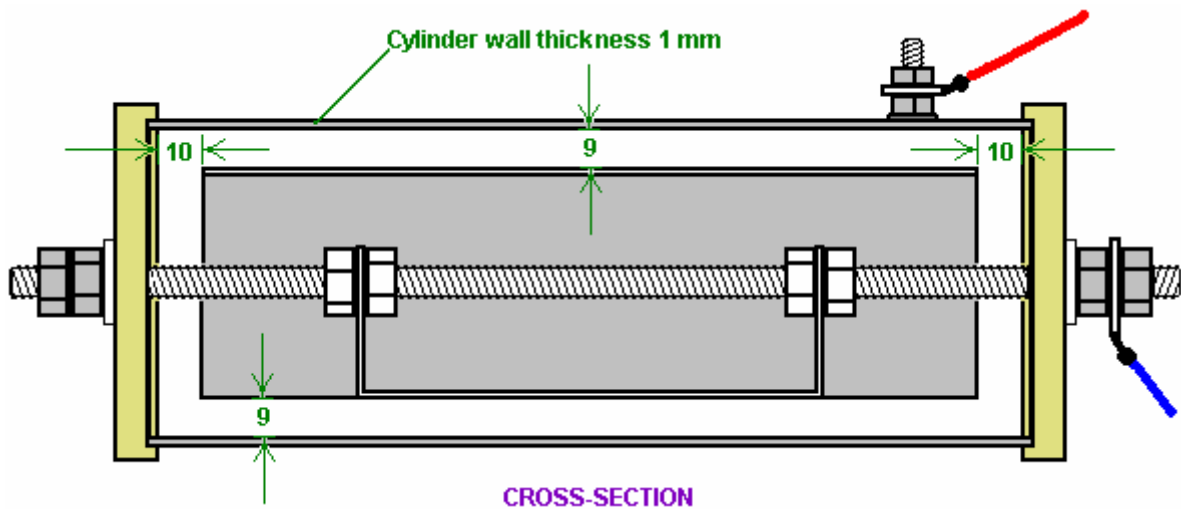

This gives a 9 mm clearance between the two cylinders and this gap stretches 360 degrees around the cylinders. The inner cylinder is located 10 mm clear of the Lexan end discs.

The units is completed by winding a coil of 2 mm diameter insulated copper wire tightly around the full length of the outer cylinder and filling the unit with electrolyte to a level of 3 mm (1/8 inch) above the top of the inner cylinder as shown here:

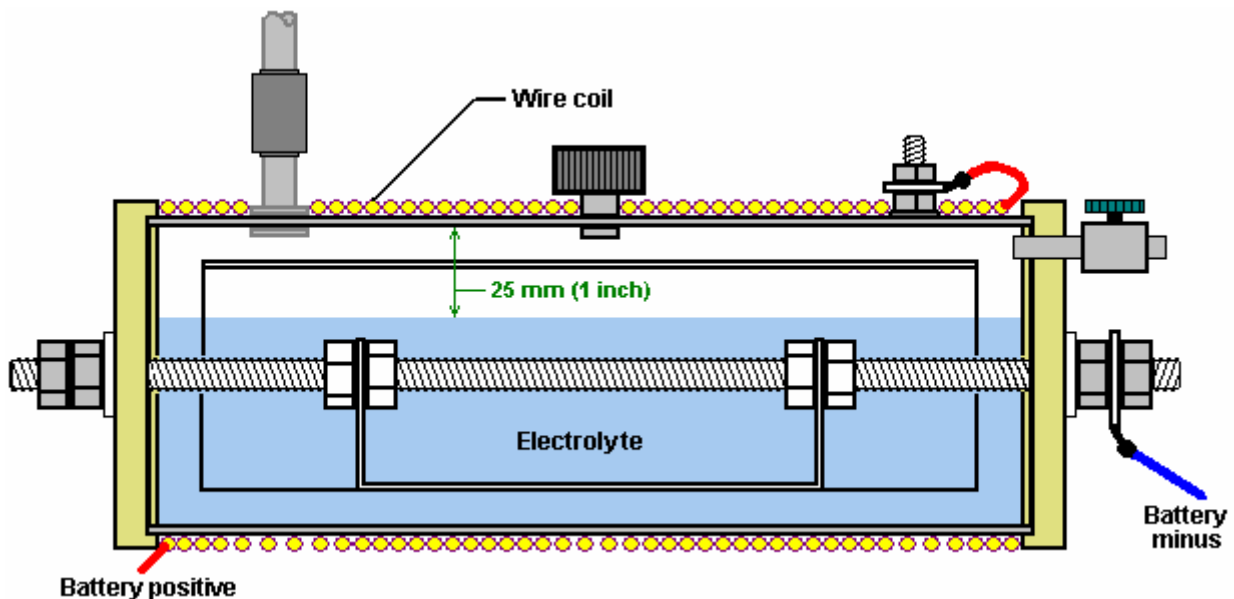

The wire used for the coil is heavy duty copper wire with an inner diameter of 2 mm, i.e. British 14 SWG wire or American 12 AWG wire. The coil is held in position at the ends of the cylinder, with plastic cable ties, as these are non-magnetic. This coil is of major importance in this design as the strong magnetic field produced by it has a very marked effect on the performance of the cell. The magnetic field produced by this coil, increases the gas production by anything from 30% to 50% and increases the production of Nitrogen Hydroxide by a factor of ten times. The electrical connection of the coil is in series with the cell, so the battery positive is not taken directly to the bolt welded to the outer cylinder, but instead it passes through the coil winding before being connected to the outer cylinder.

Installation and Use

The gas outlet pipe is connected directly to a vacuum port directly below the carburettor on the manifold of the engine. This connection is important as the cell relies on the “vacuum” (actually reduced air pressure) produced by the engine intake stroke, as part of it’s gas-forming process.

The exact method of mounting the cell in a vehicle depends on the vehicle, so this is something which you will need to think out for yourself. Be sure that you insulate the cell from the metal bodywork of the vehicle and I would suggest that you keep it away from the high-voltage electrical wiring (coil, distributor, spark plug leads, etc.).

The electrical connection arrangement is as shown here:

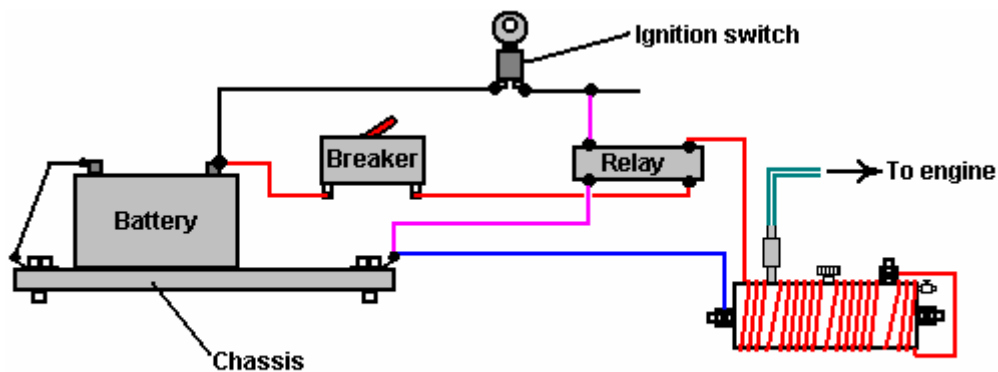

SINGLE – CYLINDER ARRANGEMENT

Or for larger engines:

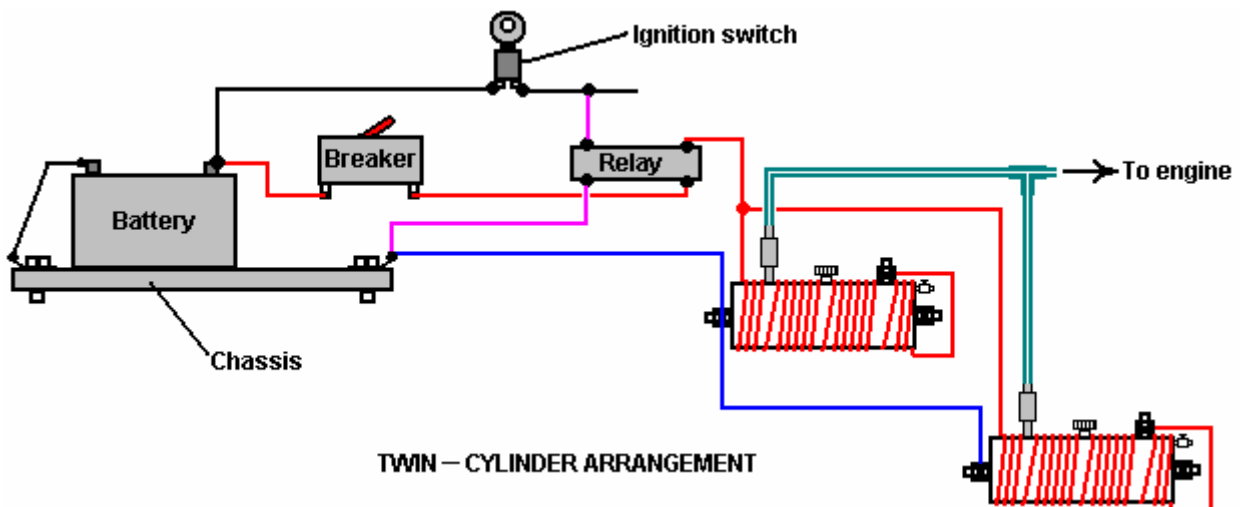

TWIN – CYLINDER ARRANGEMENT

The method of electrical connection is important. It is vital that the electrical supply is disconnected when the engine is not running. For that reason, the power to the cell(s) is taken via the vehicle’s ignition switch. In order not to load that switch unduly, a standard automotive relay is used to carry the main current, leaving

just the relay current to be handled by the ignition switch. Also, a 30 amp circuit-breaker or fuse is placed in the circuit, immediately after the battery connection. In the unlikely event of some physical problem with the cell occurring, this device will disconnect the power instantly and avoid any possibility of a short-circuit causing a fire, or of excess gas being produced when it is not needed

The water to be used in this cell needs to be selected carefully. Tap water is not acceptable as it will be contaminated with several additives - fluorine, chlorine, etc. put in it when going through the purification process of the supply company and many other chemicals picked up along the way. It is considered very important that the water be taken from a stream, preferably from where it rises, as that is the point of greatest purity. May I also suggest that the water be transported in either glass containers or stainless steel containers as these help to maintain the purity. Avoid plastic containers, because while these appear to be completely inert, they frequently are most definitely not and chemicals from their manufacture can, and do, enter any liquid contained in them.

The cell is filled to a depth of 25 mm (1 inch) below the top of the outer cylinder and then (on the first occasion only) one or two grains of rock salt are added to the cell. This addition needs to be minimal as it controls the current draw from the electrical system and the strength of the magnetic field created by that current. After using the cell for at least a week, if the gas rate is not adequate, then add one more grain of rock salt.

Getting the cell attuned to the vehicle is likely to take at least a week of use. The cell is put in place and the vehicle run using its normal fuel. The needle valve on the cell's air intake is kept completely closed during this period. The inventor opted to continue running his engine on very small amounts of petrol plus this new gas fuel - the result being 3,000 miles covered on just two gallons of petrol. If you consider this as still being a petrol powered vehicle, then getting 1,500 mpg is quite an achievement - I certainly would settle for that.

When the cell is first connected, you will notice that the engine ticks over faster and tends to rev more than it did before. It will take several days for the system to settle down. Part of this is believed to be the effect of the new magnetic coil in the engine compartment. It may be that the metal parts of the vehicle have to take up a magnetic alignment which matches the magnetic field produced by the cell. Whether that is so or not, it will take a few days before the system settles down into its final state.

It should be realised that if the vehicle has a fuel-control computer with an oxygen sensor mounted in the exhaust stream, then the oxygen sensor signal will need to be adjusted. The D17.pdf document of this series, shows in detail how to do this, should it be necessary. If the vehicle has a carburettor, then there is an advantage in fitting a one inch bore carburettor of the type found on lawnmowers, as this promotes lower pressure inside the manifold and promotes good cell operation as the lower the pressure (or the greater the "vacuum"), the higher becomes the rate of gas production.

Practical Details

The original end pieces were cut and grooved using a lathe. Most people do not own or have access to a lathe so an alternative method of cutting the discs needs to be used. The essential part of this operation is to cut an accurate groove to take the 100 mm stainless steel outer cylinder. The groove needs to be cut accurately as it needs to form an airtight seal on the end of the cylinder. Consequently, the end of the cylinder and the bottom of the groove, both need to be straight and true if they are to mate securely.

An alternative method is to use an adjustable hole-cutter drill attachment. If this is used with a drill press or a vertical stand adaptor for an electric hand drill, then if care is taken, an accurate groove of the correct dimensions can be cut. As an extra precaution, a thin layer of marine grade white "SikaFlex 291" bedding compound can be used in the bottom of the groove. Two things here. Firstly, only use the genuine Sikaflex 291 compound even though it is far more expensive than other products which claim to be equivalents - they aren't, so pay for the genuine product. Secondly, we do not want the slightest trace of the Sikaflex contacting the electrolyte if we can avoid it, so be very sparing in the amount put into the groove, no matter what you paid for it. Make sure that the bedding compound is placed only in the very bottom of the groove and not on the sides. When the cylinder is forced into the groove, a very small amount of the compound will be driven into any gap between the cylinder and the sides of the groove.

What is needed is a result which looks like this:

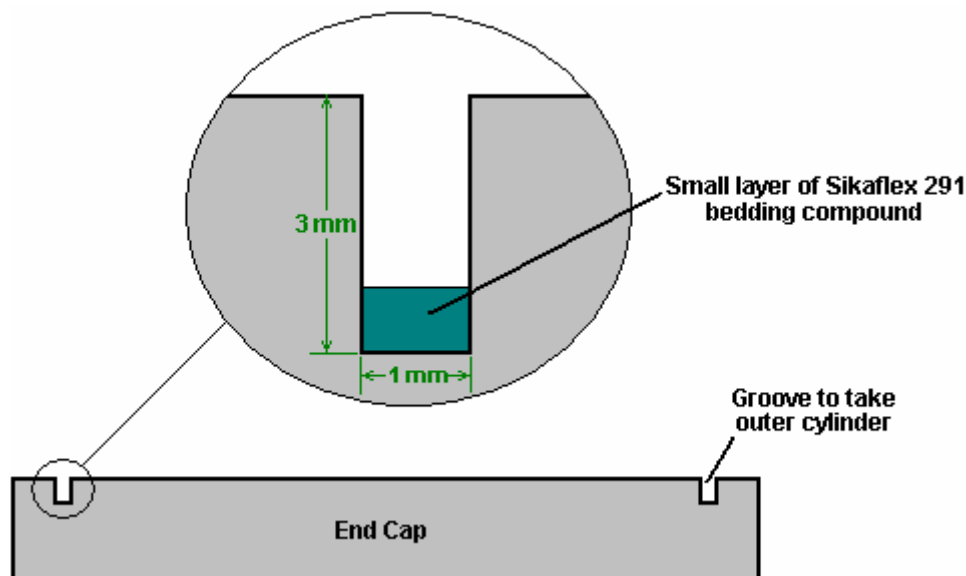

The other important part of this joint is the end of the outer cylinder. It is recommended that the cylinder be cut by hand with a hacksaw to avoid generating excessive heat which can affect the structure of the metal. To get the end exactly square, use a piece of printer paper. This has straight edges and square corners, so wrap it flat around the cylinder and manoeuvre it into place so that the overlapping edges match exactly on both sides. If the paper is flat and tight against the cylinder and the edges match exactly, then the edge of the paper will be an exact true and square line around the cylinder. Mark along the edge of the paper with a felt pen and then use that line as a guide to a perfectly square cut. To avoid excessive heat, do not use any power tool like an angle grinder on the cylinder. Just clean the edges of the cut gently with a hand file.

In the diagrams shown earlier, the gas pipe, water-filler cap and the battery positive connection bolt have all been shown on the top of the cylinder. This is only to show them clearly, and there is no need to have them positioned like that. You will notice that they all get in the way of the wire coil, which is not an advantage.

It is necessary for the gas pipe to be positioned at the top as that gives the best clearance above the water surface. The clearance should be maintained at 25 mm (1 inch). The water-filler cap which was shown on top of the cylinder, would be better positioned on one of the end caps as that would keep it out of the way of the coil of wire:

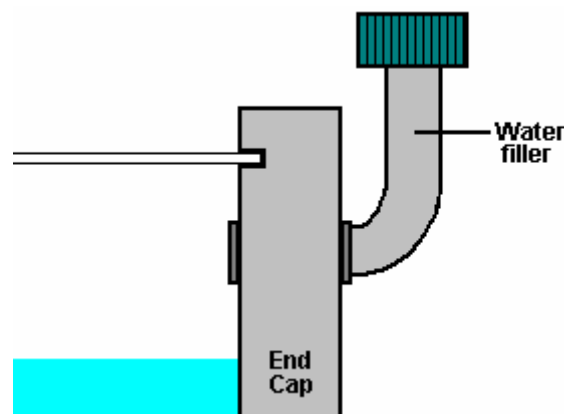

This arrangement has the advantage that it does not require a filler hole to be drilled through the steel cylinder.

It is necessary for the electrical connection to be welded to the cylinder, but it is not necessary to have a head on the bolt as that just gets in the way of the electrical coil. The best strategy is to use a longer bolt of small diameter, remove the head and weld the shaft in place with spot welds which will not get in the way of the coil, as shown below. Spot welds are very quick to make, but even they generate a good deal of heat in the pipe. Some people prefer to silver-solder the bolt shaft to the cylinder as the heating is less.

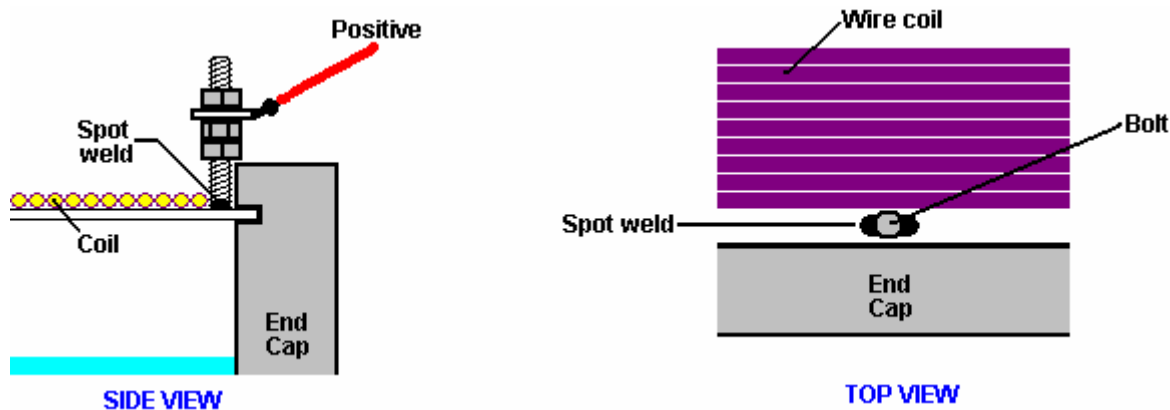

The bolt is kept just clear of the end cap to avoid fouling it when it is clamped on to the cylinder. A lock nut is used to keep the solder tag assembly clear of the outer edge of the end cap. This allows the wire coil to be wound right up to the bolt. It does not matter which end of the coil is connected to the outer cylinder, but common sense suggests that the end nearest the bolt is connected to the bolt. It is, however, important that once connected, the electrical connections to the coil are maintained ever afterwards, to ensure that the magnetic field stays in the same direction. Remember that the surrounding metal parts of the vehicle will take up a magnetic orientation matching that of the coil's magnetic field, so you do not want to keep changing the direction of the coil's magnetic field.

When welding the bolt to the outer cylinder, be sure you use stainless steel wire. The joint needs to be made with a MIG or TIG welder. If you don't have one and can't hire one, then your local metal fabrication shop will make the spot welds for you in less than a minute and probably not charge you for doing them.

The grade of stainless steel in the cylinders is important. Grade 316L is nearly non-magnetic, so if you hold the cylinder with its sides vertical and place a magnet against the cylinder, the magnet should fall off under its own weight. Try this test no matter what grade the stainless steel is supposed to be, as some steels are not labelled correctly. There is a good chance that you will be able to find suitable tubing at your local scrap yard, but be careful on sizing. The 9 mm gap between the outer 100 mm diameter cylinder and the inner cylinder's 80 mm diameter, is very important indeed. This gap needs to be 9 mm (11/32 inch) so if really necessary to vary the diameters slightly up or down, be sure to pick material which gives the correct gap between the cylinders. Seamless piping is usually preferred to pipes which have seams as the seam welding tends to generate a magnetic effect in the steel. However, if a seamed pipe passes the magnet test with the magnet falling off it, it is definitely good material for the cell.

If you can get it, a good material for the 12 mm (1/2 inch) pipe running to the carburettor manifold, is aluminium. Please remember that the one-way valve on the cell's output pipe needs to be connected to this pipe with a material which insulates the two metal components. The suggested piping is therefore: the cell output is via a stainless steel pipe connector, connected directly to the one-way valve, which then has a plastic pipe connection to the aluminium tube which runs all the way to the manifold. Please remember to insulate the cell from the vehicle chassis and components to avoid a short-circuit.

An alternative to using the rather expensive "Lexan" for the end caps, is to use "UHMWP" - Ultra-High Molecular Weight Polyethylene which is cheap and easy to obtain as plastic food-chopping boards are usually made from it. The advantage of Lexan is that it is transparent and so the level of the electrolyte can be seen without the need for removing the water-filler cap.

It has been suggested that the topping up of water in the cell can be automatic if you wish it to be so. For this, a water-level sensor circuit is used to drive a standard windscreen-washer water pump when the level of the electrolyte falls below the design level. The sensor itself, can be a bolt running through one of the end caps as shown here:

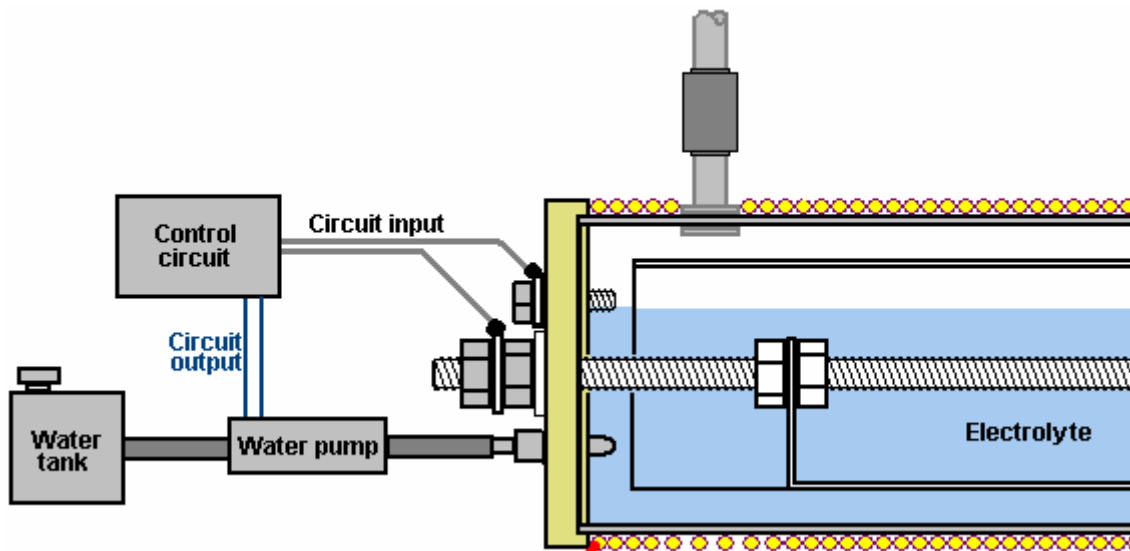

When the electrolyte level drops below the upper bolt, the circuit contact to the control circuit is broken and the circuit responds by powering up the water pump, which injects a little water to bring the electrolyte level back up to where it should be. When the vehicle is moving, the surface of the electrolyte will not be steady as shown in the diagram, so the control circuit needs to have an averaging section which prevents the water pump being switched on until the circuit input has been missing for several seconds.

Circuitry suitable for this is shown in Chapter 12, and there is no reason why you should not design and build your own circuit for this.

In the initial stages of testing and installation, when adding rock salt, be very sparing indeed. Add just one grain at a time because the salt ions are very effective in carrying current through the electrolyte solution. Also, if too much is added, it is difficult to reduce the concentration as more water needs to be added, which involves draining off some of the water already in the cell. It is much easier to take your time and add very, very little salt. Give the salt grain plenty of time to dissolve and spread out throughout the electrolyte before checking the cell performance again.

Let me remind you that during the initial cell testing, the air intake needle valve is closed completely and it is not eased open until the engine is running satisfactorily. In the engine acclimatisation period, the engine should be run on it's normal fuel and the cell just used as a booster. Remember that it will take at least a week for the vehicle to settle down to it's new method of operation. There is no particular hurry, so take your time and don't rush things.

If the vehicle is fitted with computer control of the fuel supply, it may be necessary to apply some control to the unit by adjusting the signal coming from the oxygen sensor placed in the vehicle's exhaust system. The information on how to do this is shown in considerable detail in Chapter 10.

Some questions have been asked about this cell:

1. Does petrol have to be used or can the engine be run on the cell alone?

Answer: No, you can eventually eliminate petrol altogether but the engine runs so cleanly that old carbon deposits around the piston rings and elsewhere will get cleaned away and the components may rust. These parts can eventually be replaced with stainless steel versions or instead of that, it is probably possible to avoid replacements by the use of the oil additive called "Vacclaisocryptene QX and Molybdenum Disulfide" - see <http://www.clickspokane.com/vacclaisocryptene/> for details. This additive reduces wear to such a degree that engine life may be doubled, no matter what fuel is being used.

2. Why is the unit 300 mm long?

Answer: Just for convenience in fitting it into the engine compartment. It can easily be longer if space allows it. The longer the unit, the greater the gas production and that is why two 300 mm cells are needed for engines over 2 litres in capacity.

3. Does the cell body need to be made from seamless pipe?

Answer: Seamless 316L-grade stainless steel is preferred.

4. How do you determine the amount of rock salt to add to the water in the cell?

Answer: The amount varies with the type and size of engine being dealt with. You want the minimum current through the coil so start with one grain and increase it only very gradually with tiny amounts. If the cell is being mounted in the engine compartment of a vehicle, then the make, model and size of the vehicle will affect the amount due to the magnetic effect of metal components near the cell.

5. Does it matter which end of the coil is attached to the outer cylinder?

Answer: No, it can be either end.

6. Is the pipe diameter shown from the cell to the engine the best size?

Answer: The 1/2 inch diameter is very good as it increases the "vacuum" inside the cell as the engine runs. When first testing the engine, remember that the needle valve is completely shut off, and when it is opened during tuning, it is only opened to a minimal setting.

7. Are the exhaust emissions damaging to the environment?

Answer: Some years ago, a Mercedes car dealer ran his own emissions test on a new Mercedes diesel, using his own equipment. He found that the emissions were reduced by 50% and the engine power increased by 12%. The engine ran better, cleaner and quieter. He was fired for doing this.

Other independent gas-analyser tests showed that there is an increase in water emissions and a drop in carbon emissions as less fossil fuel is used. It was also noted that the volume of gas produced by the cell was affected by where it was mounted in the engine compartment. This is thought to be due to the magnetic effect on the cell.

Update Information:

Question 1: Where do we connect the outlet hose from the D18 fuel system to the engine on a late model car with fuel injection system?

Response: There is a throttle body on the engine and it is connected to a rubber hose which goes to the air filter. Typically, the rubber hose attaches to the throttle body and is clamped in place. A hole needs to be punched through the rubber housing approximately two inches (50 mm) from the throttle body. A brass fitting needs to be put into this opening. It will have a flange on one end and the other end will be threaded to accept a nut to hold it in place. This brass fitting will be the attachment point for the incoming fuel line from the D18 system and/or any other booster. For the D18 horizontal system, the size of the fitting should be half-inch (12 mm) so as to be able to maintain the proper vacuum pressure to the D18 fuel system.

Important Note: Since the practice of using alternate fuels by the public is not widely accepted it would be expedient to locate the fuel inlet opening on the under side of the hose out of plain view. This will help the user pass vehicle inspections and keep inquisitive persons from asking too many questions.

Question 2: What do I do I have to do to make the on-board computer function properly with my new booster?

Response: You need to install an electronic mixer control system. Plans for such a system used to be downloaded from <http://www.better-mileage.com>. This control system will fool the on-board ECU into thinking that all is okay and it will continue to work as normal with no problems. There are two corrections that need to be made to the system to make it work properly. They are outlined in red on this diagram:

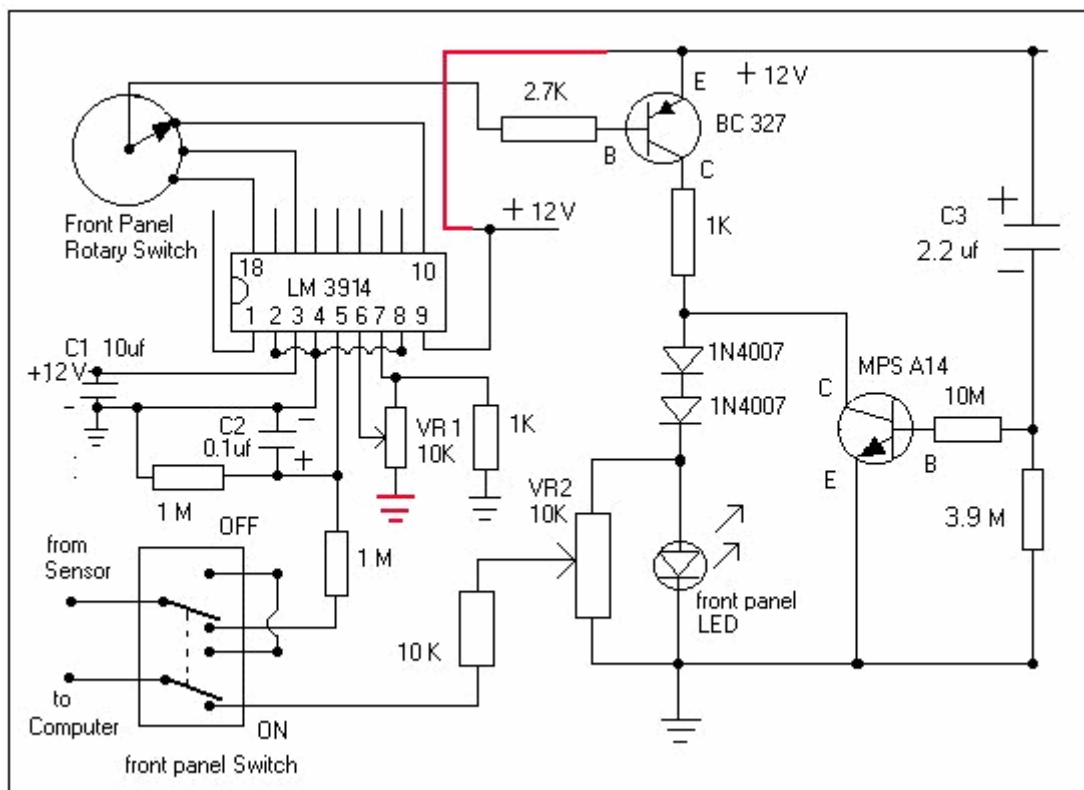

Note: In this application the D18 cell is only being used as a booster. Therefore the engine still is using a hydrocarbon fuel. There are numerous systems available such as “megasquirt”, which allow for tweaking the amount of fuel being injected into the engine, and for making numerous other on-board computer adjustments to your Electronic Control Unit, for those of you who want to use nitrogen hydroxide as your only fuel and/or want to reduce the amount of petrol being injected into the engine.

Air Inlet Port: None required!

Ageing of Cell / Cell Break In: Use only the proper water as described below. The cell needs to be drained every day during the ageing process. Filter the water five to seven times through a cotton T-shirt. Collect the water only in glass jars, and do not touch it with your bare hands. Re-use the water and top the cell up with the proper water. Use absolutely no electrolytes (such as salt or potassium hydroxide). You can use natural water which has not seen light and that has not been charged such as, well, cave, or spring water at it’s source. Age the cell until it becomes a slight bronze in colour and does not generate any more gunk inside the cell. The purpose of the break-in period is to purge impurities from the cell.

Cell Current: The peak electrical current with the proper water is approximately 10 amps.

The Positive Electrode: the inner cylinder should be connected to the battery positive. This should be done via an automotive relay to assure proper shutdown of the cell when the engine has been switched off.

The Negative Electrode: This is the outer cylinder, which is connected via a metal strap to the chassis.

Construction: The inner cylinder is separated from the outer cylinder by spacers made out of ebonite or any other material which will not deteriorate within the cell. The objective is to keep the plates at an equal 9 mm spacing throughout the cell. The inner cylinder is connected to the threaded rod via a stainless steel wire strap, which is silver soldered in place at both ends of the cylinder. The threaded rod forms the battery positive connection point on the outside of the cell.

Drain: There should be a drain at the bottom of one of the end plates, so that you can drain the cell without having to remove it from the vehicle. The water will need to be drained and filtered at least once every three weeks. Drain the cell contents into a glass container. Do not touch the water with your bare hands. Filter the water at least five times (seven is better). Use a cotton T-shirt for filtering. Never throw the water away but just filter it. Put the water back in the cell and top the cell off using only pre-charged water.

Electrical Generation: The cell will continue to produce electricity after engine shutdown which will also lead to gas production, so take the precaution of discharging the cell.

Electrolyte: Use absolutely no electrolyte (including salt) at any time. This has been found to decrease the fuel output of the cell and also to have caused unnecessary damage to the plates of the cell.

Engine Timing: Yes, you have to adjust it to your engine. This is a very important aspect of getting high mileage with this system. Each engine is different and therefore each engine has a different adjustment.

Fuel Outlet Piping: Copper piping is recommended as unlike plastic or rubber, it will reduce condensation of water into the fuel lines and thereby reduce the level of water getting into the engine.

Fuel Outlet Ports: There are two of them positioned on opposing ends of the cell. If you are using a 12" cell, then they are positioned 3" in from each end of the cell. If you are using an 8" cell then they are positioned 2" in from each end of the cell. Make one outlet port half-inch (12 mm) in diameter and the other three-quarter of an inch (18 mm) in diameter. Make sure that the piping from the ports extends into the cell by at least an eighth of an inch (3 mm). This is to prevent water vapour accumulating at the top of the cell from entering the fuel outlet ports. This measure has been found to reduce water reaching the engine.

Leak Prevention: Use rubber gaskets - these can be the type used for domestic plumbing.

One-way Valves: One-way valves are not used on the fuel outlet pipes.

Outlet Pipe Connections: The half-inch (12 mm) pipe is connected to the engine after the butterfly valve, while the three-quarters of an inch (18 mm) pipe is connected to the engine before the butterfly valve.

Cylinder Preparation: The inside of the 4" (100 mm) outer cylinder and the outside of the inner cylinder, which are the opposing cell plates should be sanded very well with medium grit sand paper to rough up the surface. Two sanding directions at right angles to each other should be used. This will insure better cell productivity later. It is important that there should be no direct contact between the cell plates and your bare hands, so wear rubber gloves when sanding and then assembling the cell.

Voltage: Only 12 volts is required to run the cell, a typical car battery is all you need to power the cell.

Water Selection: Use only natural water that has come out of the ground and not seen light such as well, cave, or spring water at it's source. **Important:** Only add charged water to the cell. Water being used must have a pH of somewhere between 6.4 & 6.5 (slightly acidic). Do not use water with a pH of 7 or higher. The water is charged using a regular Joe Cell with electrodes separated by 3/16" (5 mm) for best results. The details of a Joe Cell can be found in D10.pdf which is a document in this series.

Water Level: Maintain the water level at approximately half full, that is, just covering the threaded rod.

E-mail from a contact:

Hi,

Thanks so much for shedding light into my cell cleaning concerns. I haven't been posting lately since right now the cell is already hooked up in my test car and I've been doing some tests with it day and night.

For once, I can personally tell you that the cell in fact works! However, with my results, it is hard to believe that the Nitrogen Hydroxide produced is enough to make the car get 1500 mpg. When the Nitrogen Hydroxide is allowed to enter the engine, the car starts to rev erratically for 2-3 minutes and then steadies itself thereafter. I noticed an increase of about 800-1400 rpm in my ECU data-logger once the Nitrogen Hydroxide cell is put into the equation. I then adjusted my Engine Management System and removed 15% of the petrol going into the system and drove around the block for a good 15 minutes or so. My exhaust gas temperature rose from 90 Celsius to 97 Celsius which is still fairly acceptable.

I went back to the garage and further adjusted the petrol to less 20% in total and at this point, the car began to vibrate erratically as if it was gasping for air. Upon noticing this, I concluded that not enough NOH must be getting into the ICE or something. The next thing I did was I mounted my old 304L cell alongside with the 316L currently installed. With two cells in the equation, petrol at 20% less did not cause vibrations at all, but mind you that even at 50% less petrol and without Nitrogen Hydroxide cells installed, the car will still run by petrol alone. It was getting dark and so I maxed out my engine management and removed 50% petrol from

the equation with the two NOH cells running side by side. Again, there were vibrations and it was very evident but my brother and I drove the car around the block anyway. Within just five minutes of leaving the garage, the engine temperature rose from 97 Celsius to 111 Celsius and was still rising. I also noticed that the car was underpowered to say the least. We drove up and down a parking complex to test out the non-sloshing design and from my guess it performed pretty well.

To cut a long story short, the cell produced some kind of fuel (NOH or HHO), but it was not enough to power the car when 50% petrol was removed even with 2 cells running. I am currently getting 22 mpg with this test car so I assume that 50% less petrol should give me something like 44 mpg on city driving and probably 60 mpg for long trips. These numbers are very small as compared to the 1500 mpg that the inventor reported. Maybe the cell needs more time to acclimatise to the test car... but I've been getting same results for 3 days now.

I am currently building two new 316L cells which will incorporate my non-slosh design and which have a vacuum-powered water top up system. I also believe that the gap inside the 3" cell should be sealed off since there is no reaction happening in this part of the cell and it only increases the resistance of the water to electricity. I also included this in my new cell design. I will probably publish it if I find that it produces more gas than the D18 design.

By the way, I've contacted someone in my city who sells 914L stainless steel. However, he told me that 914L requires special handling and special tools and it is much much harder to work on with hand tools alone. He gave me a 1" diameter tube as a sample to see if I can work with it. It's really, really expensive. One cut of a 4" diameter 914L will cost just as much as 2 years worth of gasoline (around 70 FULL TANKS).

And: Bore water is water pumped out of the ground. It is similar to well water, the only difference being in the way the water is gathered. Well water is dug from the ground while bore water is SUCKED out of the ground by means of an electric or manual pump.

What I noticed so far is that there is really a lot of steaming going on inside the cell. Converting steam into Hydroxy Gas requires less power than water, so I suspect that this steaming is good. The suggestion to only fill the cylinder half-way actually makes sense as this would allow a greater storage space for the steam and pretty much eliminates water sloshing problems. I have also tried switching the polarities on my 304L cell a couple of times but it did not make any noticeable difference. I will try to make a test run with a half-filled cell and tell you my results.

And: The outlet tubes are positioned at 3" on both ends as this might be the optimum position where less water will accidentally splash into the ports. I was also told that these tubes extend inwards into the cell for about 3 mm so that the water building up in the top surface will not be allowed to slide accidentally into the outlet tubes. It makes sense because with the tubes positioned at 3" away from the edge, it actually gives you about 30 degrees of angle before one of the ports are completely submerged in the water. Also, if the cell is just half-filled, this could actually give us 45 degrees which is relatively a very steep slope to say the least.

The 1/2" and the 3/4" remains a mystery for me. The only reason I can think of is that one of these tubes might be directed before the butterfly valve and the other one placed after the butterfly valve. I would suspect that the smaller tube (1/2") was placed after the butterfly valve and the larger tube was placed before the butterfly valve. This will make sense because the negative pressure during idle is naturally constant and would only require less NOH, while stepping on the accelerator will result in variable pressures which will require larger amounts of NOH. This is only my theory and I am in no position to declare that this is in fact the reason behind the different tube sizes.

I cannot measure the amount of air entering my cell because my end caps are not see-through plexiglass. I only open my Air Inlet Valve halfway through. At this position, I could see a difference in the rpm and at the same time no water could be seen creeping into the tubes. If I open the valve all the way, the rpm will continue to increase but at the same time so does the water in the tubes.

This is my third installation and probably the most successful one. It has been on my test car for five days now but it was not switched on all the time. I found too much water creeping in into the tubes and so I had to shut it off and run the car normally just to make sure no rusting will occur in my engine. I estimate that I have the cell switched on and running for a total of maybe 12 to 14 hours as of today.

From another user:

Hi,

thanks for the info about the EFI thing! it worked on my wife's Passat. After a few weeks of searching we were able to find smaller injectors for the car as the variable resistor trick only gave us CEL errors. I do notice that the engine's rpm is changing somewhat with every turn of the variable resistor but the relationship is far from linear.

The cell will in fact continue to produce fuel for some time after the power source has been cut. This will tell you that you have the correct water in your cell and you should be happy! What you should do, is to mount a small 12V computer fan beside your cell so that this fan will feed on the power created by cell and reduce the fuel build-up. If you want to be totally safe, then you should put another outlet port on top of the cell and open this every time you park your vehicle. If you want to automate things to avoid constant accessing of the cell, then you can get an electronic valve which will also feed on the excess power produced by the cell. I will not explain further on how this can be achieved, but basically, the valve and fan should only be activated when the engine is off. A few switches here and there will do the trick.

Regarding outlet ports, you are correct to assume that you should have separate lines. One line before the butterfly valve and another line after it, is quite correct and this is what I am doing right now. You should however, have the means to regulate these lines as you will soon realise that too much fuel is actually bad for the engine's health. Also make sure to top up the water regularly as too much empty space inside the cell will make the cell into a bomb!

My concern right now is that if our cells were made half-filled, then it would mean that more than a litre of empty space would be left inside the cell. One litre of Hydroxy or Nitrogen Hydroxide will definitely turn our D18s into a bomb. We should therefore provide a means of venting the NOH build-up when the car is parked. My cell does not produce 13v when shut off as of this moment, which obviously explains the inefficiency I am getting.

Another person:

Hi,

I've seen your set-up pictures at photobucket and I am surprised at the level of professionalism that you are dedicating into this project. I am even more surprised that you claim that your current set-up doesn't work at all! What gives???

Now for my take on your set-up: it seems that the pipes you are using are too small... is it 1/4" ? If so, try to use 1/2" as the minimum. Your fuel output on the end caps should be placed on top of the cell, as I previously stated in my messages. Your water inlet valve should be placed lower. I think the main problem of your set-up is that the introduction of air is placed very near your fuel output. Try to keep these two as far away from each other as possible.

Do not rely on the inventor's set-up as shown on the famous picture on his V8. This picture circulated years ago and to my knowledge, this is not the current set-up that gave him extreme mileage. Last I heard about this guy was that he also used a petrol vaporiser and this was one of the key components in achieving unimaginable mileage on his truck. I for one am not getting even half the mileage that this guy claims. With years of tweaking an old carby truck, I was able to get 225 mpg and this was good enough for me because sometimes I get 300+ on long drives to the country. You should also bear in mind that the longer that petrol stays in your tank, the more evaporation will take place. Upon installing a high mileage device, I realised that most of the petrol is wasted by just sitting in the tank and evaporating.

The air inlet port should be kept as far away from the output ports as possible. It is the water that does the work and not the stainless steel. It should be possible to drain the water completely without removing the cell from the car. The air inlet is a dual purpose port which is placed on the dead bottom of the end caps. Tuning the car to work efficiently with the cell can take a very long time. Make sure that the cell is producing gas aggressively before mounting it on the car.

If you always have the fuel tank full at all times, it reduces fuel loss through evaporation, since on a hot summer day, you are probably losing 12-18% of the fuel through evaporation and what will be left inside the

tank will be less volatile, with bigger molecule sizes which won't combust completely in the engine, which in turn, shortens the life of the catalytic converter and causes more pollution.

System Summary by Contact: I use two 8" cells on my truck with two gas ports on each cell for a total of four ports. Two Ports to Manifold and two Ports to air intake, and there are no one-way valves, instead I use small fuel filters to make sure that water entering the engine is minimised, and at the same time oil is prevented from going into the cell.

I drilled a small hole on the bottom of both fuel filters and sealed them with a small screw plus a rubber ring. From time to time, I remove the screw to drain the water from the filters. The water inside the filters is dirty and should not be recycled for use in the cell. No salt or KOH is used because once the cell is aged and ready, catalysts are no longer required as they will only produce more dirt inside the cells.

Now here comes the most controversial part... NO AIR INLET PORT OPENING!! I don't have an opening for air in my cells. I'm sorry that I've been keeping this from you since day one. I know I told you about properly proportioning your air to the amount of gas that your cell produces. This was the same information that I got from another guy years ago. Although this might be true, you can never be precise on how much gas your cell is producing as the temperatures and pressures you get in the engine vary from time to time... Right now you might be thinking that I may be using a different system all along... this is what I was wanting to avoid that is why I withheld this information from you. But don't worry, there's an explanation for everything...

Simple analysis of the cell design will tell you that it is plainly impossible to remove all the air inside the cell. Air will always enter the weakest point in your cell no matter how air-tight you think your cell is. Take your tires for example: air is continuously escaping your tires no matter how air-tight you may think they are. Needless to say, your cell is not air-tight to begin with so why the hell would you need another air opening? As controversial as I may sound, I found this design to be the most efficient.

I use a Joe Cell to charge/clean my water. I don't have a working Joe Cell, I just use it for electrolysis to remove the junk out of the water before putting it in the cells in my car. I have a drain valve on the bottom of one cap and I usually drain and filter my cell water whenever I feel like it. If you have good water and an aged cell, you will produce hydroxy in no time. 304, 316, 317 stainless steel - it does not matter, just as long as you are able to produce gas and that it does not rust quickly. More expensive s/s will tend to outperform cheaper s/s but cheap s/s will still work!

I don't have a magnetic coil and I never heard of this until you pointed it out to me. It did not take me weeks to age the cell, the hard part is really the water. You can use plain old tap and maybe get some gas... hooray! You have just made a hydrogen booster! Or you can follow my lead, and use good water and make fossil fuel nearly obsolete. The water level inside the cell may not matter, but I find that the cell will produce more gas when there is less water inside it. However, for safety reasons, I almost always make sure that the cell is 3/4 filled with water and 1/4 empty space. Another important thing to bear in mind is the steaming inside the cell. If you use plastic or rubber tubes, the steam might condense back into water before getting into the engine. Use copper tubes to make sure that steam will not condense. To my knowledge, the salt is just used to remove the protective layer on the s/s which actually prevents the bubbles from dislodging quickly. You can also age your cells in many other ways and this won't be a problem.

That main idea is, get your cells to produce hydroxy without using catalysts. The nitrogen part will come as an accident and I cannot explain how this happens. I am still a little sceptical about the nitrogen actually bonding with the hydroxide. Sometimes I think that it is only the hydroxy and steam which are doing all the work... You are entitled to your own opinion.

The wife gets around twice her previous mileage on the Passat. The injector change can only do so much. I only installed one 10" cell to keep all the stock parts intact. She is happy with it and so my EFI project stops here.

Please let me stress again that many people have built this device and tried to get it to work without any success whatsoever, and that is why it is in this chapter.

However, having emphasised those concerns and provisos, I was informed early in 2010, that Jim Bundock in the UK has had considerable success using this design as a booster. He estimates that using this device has saved him about £500 over a two year period. Here is some detail from him:



These two cells have been in use in two different vehicles for more than a year now. The vehicles are Ford Transit vans with 2.5 litre diesel engines. One is sixteen years old and the other is seventeen years old and the Nitro Cells have given a 10 mpg improvement from the day that they were installed in spite of the vans being heavily loaded when being used. The original mpg was 25, so the resulting 35 mpg represents a 40% improvement over a long period.

Jim says: these cells were built from the plans shown above, the only variation being that instead of bending the tabs for the inner tube, tabs were silver-soldered at the end of the inner tubes as shown here:



These cells are run without salt and they work equally well without the wire wrap suggested in the design. The vertical cell is 18 inches tall and 4 inches in diameter and it has a rubber diaphragm on top which acts both as a seal and as an anti-slosh device. The inner cylinder gives a 9 mm gap between the inner and outer cylinders. The cell ends and spacers are made from plastic food-chopping board. The top spacers are about 30 mm long as it was found that vibration tended to dislodge shorter ones. This vertical "slow" cell is very easy to build.

On one of the “fast” horizontal units, there is a length of blue pipe:

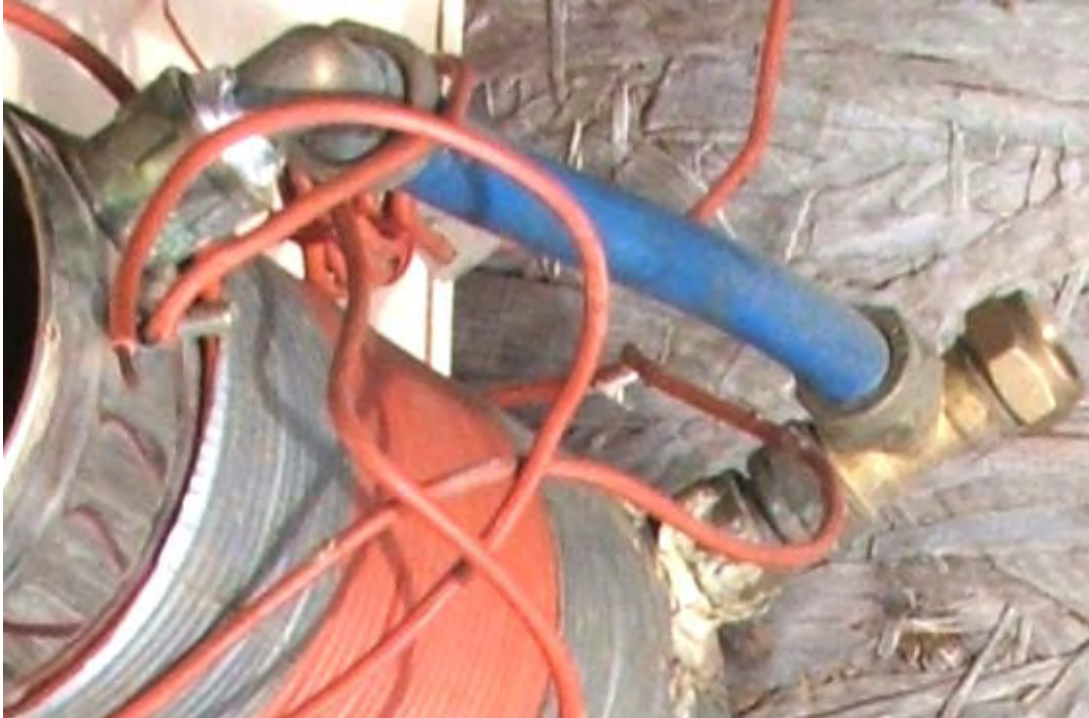

This prevents water from entering the engine when a certain boy-racer tries to negotiate corners at the speed of light. The horizontal cell was plumbed in using a plastic 12mm pipe connected to the inlet manifold. Personally, I don't think these cells like speed and they seem to respond best when driving around 50 mph – this is for a single cell on a diesel engine. The cell is wired in as standard, only on a diesel, the relay is connected to the fuel cut-off valve, making it very easy to wire, and when the engine is switched off, then the cell is turned off at the same time. Using a miniature version of the upright cell, the bore-hole water which I use, is pre-charged on the bench for as long as I feel it needs to be, just to remove some of the material suspended in it. Topping up with water is done every 750 miles or so and takes about an egg cup full of water. All in all, the Nitro Cell is a good honest working device, it is a simple drive-and-go piece of kit that has saved me around £500 in two years and will carry on doing that for ever.

The “HydroStar” and “HydroGen” Systems.

There are various sets of plans for car conversions and many of them are worthless and intended to waste the time and money of people who are interested in moving away from fossil fuel products. It is not possible for anyone to say with assurance that these plans do not work since even if you construct in exact accordance with the plans and your replication fails to come anywhere close to working, all that can be truthfully said is that your own replication was useless. We need to avoid this sort of comment, since for example, the Joe Cell does indeed work and can power a vehicle in a completely fuel-less mode, **but**, most people fail to get it operational. Consequently, it is completely wrong to write off the Joe Cell, but warnings on the difficulty of getting it working should always be given.

In the case of the HydroStar and HydroGen plans, I have never heard of anyone who has ever got either of them working. Also, experienced people are quite convinced that the design is seriously flawed and never worked in the first place. Still, it is up to you to make up your own mind on this, and so these plans are mentioned in this chapter.

The plans shown here can be downloaded free from <http://www.free-energy-info.tuks.nl/P62.pdf> and they are intended for free use by anyone who wants to use them. Please remember that should you decide to undertake any work of this nature, nobody other than yourself is in any way responsible for any loss or damage which might result. The full manual for an essentially updated version of the design is included under the name “HydroGen” and can be downloaded free from <http://www.free-energy-info.tuks.nl/P61.pdf>.

It is recommended that should experimental work be undertaken on a car, then the car chosen should be of little value and that all existing parts be kept so that the vehicle can be restored to its present fossil-oil

burning status should you choose to do so. It is also suggested that you use a car which is not important to your present transport needs. It is claimed that the modified car will travel 50 to 300 miles per gallon of water depending on how well it is tuned. The system is set up like this:

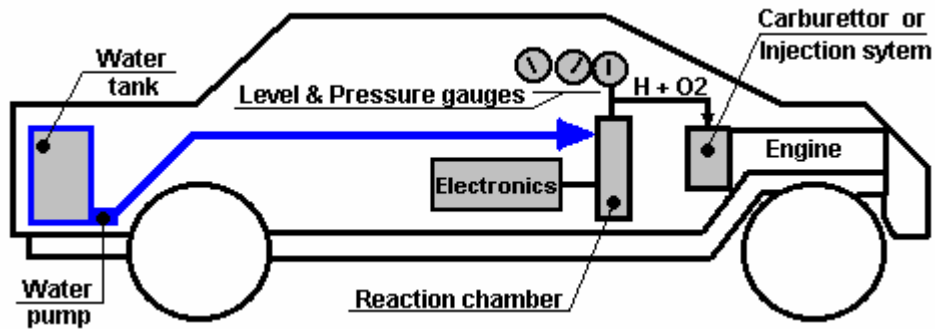

Here, the car has an extra tank installed to contain a reserve of water. This is used to maintain the water level in the reaction chamber which contains the electrode plates. The electrodes are driven by the electronics which applies a pulsed waveform to them in the 0.5 to 5.0 Amp range. The electronics box is powered directly from the existing car electrics. The Hydrogen/Oxygen mix which is the output from the reaction chamber is fed directly into the existing carburettor or fuel-injection system.

The start-up procedure is to power up the electronics and wait for the gas pressure to reach the 30 - 60 psi range. Then the car ignition is operated as normal to start the engine. The accelerator pedal is wired into the electronics to give more power to the electrode plates the further the pedal is pressed. This increases the gas production rate as the throttle is operated.

Electronic Control Circuit

The diagrams show a simple circuit to control and drive this mini-system. You are going to make a 'square-pulse' signal that you can watch on an oscilloscope. The premise given by the literature is: the faster you want to go down the road, the 'fatter' you make the pulses going into the reaction chamber. Duty cycle will vary with the throttle from a 10% Mark/Space ratio (10% on and 90% off) with the pedal up, to a 90% Mark/Space ratio with the pedal fully down.

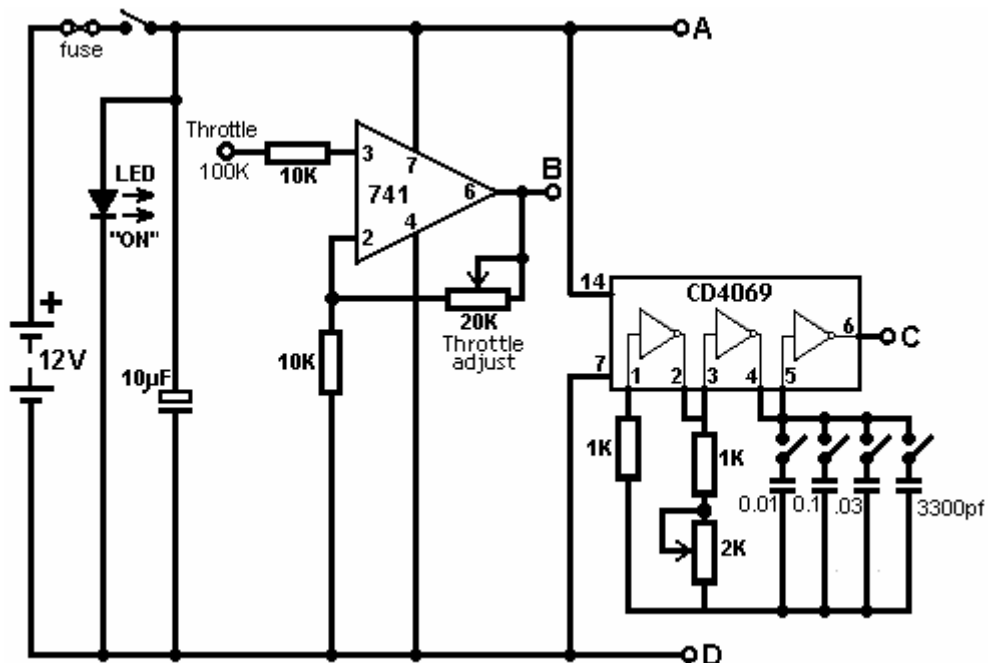

There are many ways to generate pulses. This circuit uses an "NE555" integrated circuit. The output switching transistor must be rated at 5 Amps, 12V for pulsed operation.

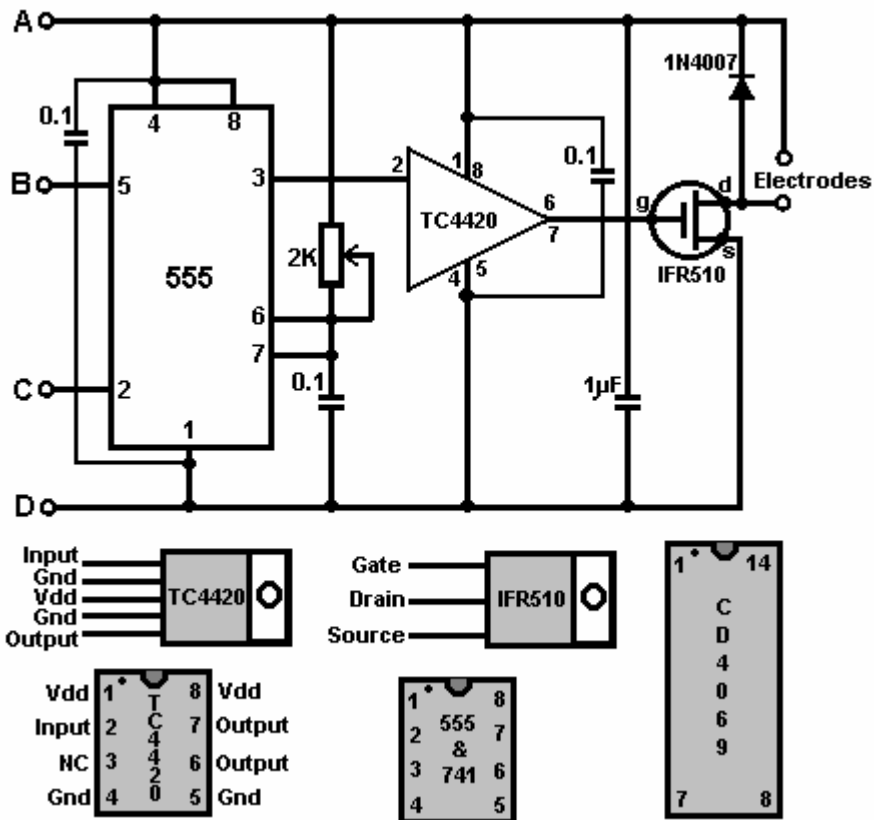

The output of the 741 integrated circuit is adjusted via its 2K variable resistor, to give an output voltage (at point 'B' in the circuit diagram) of 1 Volt when the car throttle is fully up, and 4 Volts when the throttle is fully down.

The CD4069 is just an IC containing six inverters. It can handle a supply voltage of up to 18V and is wired here as an oscillator. Its four capacitors are likely to be used in just four combinations: C1, C+C2, C+C2+C3, and C1+C2+C3+C4 as these are the most widely spaced tuning ranges. There are, of course, eleven other capacitor combinations which can be switched with this arrangement of four switches.

Important Note

Gary of G. L. Chemelec commenting on "The HydroStar" circuit which sounds to be based on the same style of circuitry, states that the circuit and design are riddled with serious errors, some of which are:

1. The use of the 741 WILL NOT WORK! Pin 5 is a Voltage Control pin that already has its own voltage of 2/3 of the Supply voltage so it requires a pull down resistor, not an IC to control it.
2. The 2K Pulse width adjust will blow the 555 timer if adjusted all the way down. It needs an additional resistor to limit current to those pins on the IC.
3. The output of the 555, Pin 3 is fed to the CD4059 as well as a TC4420CPA (Mosfet Driver). This driver is a waste of money as it is not needed.
4. The Output of the TC4420CPA is then fed to the IRF510 Mosfet which is now obsolete, however you can use an RFP50N06 (50V, 60A).
5. There is no schematic of the CD4059. They should have shown pin 1 as in, pin 23 as out, pins 3, 10, 13, 14, and 24 connected to 12 volts and pins 2, 4, 5, 6, 7, 8, 9, 11, 12, 15, 16, 17, 18, 19, 20, 21, and 22 connected to ground.
6. The "Strength Adjust" Only Needs the variable resistor connected to Pin 5 and the Ground. The Connection of this control to the Supply Voltage Make Absolutely No Difference in the Output Waveforms, as the IC only needs a 2/3's voltage on this Pin and this is supplied internally, Within the IC.
7. The "Frequency Adjust", Connects to Pins 6 & 7 of This 555. Supply to the battery Will Destroy the 555. so another resistor is needed to prevent this from happening.

This is just a small list of what is wrong. There is MUCH MORE and even after the thing is built it does NOT WORK! If you want to experiment then please do, but I would suggest you just make your own Pulse Width Modulator.

There are also many problems with the design of the reaction chamber and simply put, even if you did get it to work you would need more of these units than you could ever fit in your car to even think about running the engine. Simply put, the unit will NOT create enough gas to run much of anything. Don't get me wrong, I do think that the idea is GREAT and that it can be done.

Reaction chamber:

The suggested reaction chamber arrangement is:

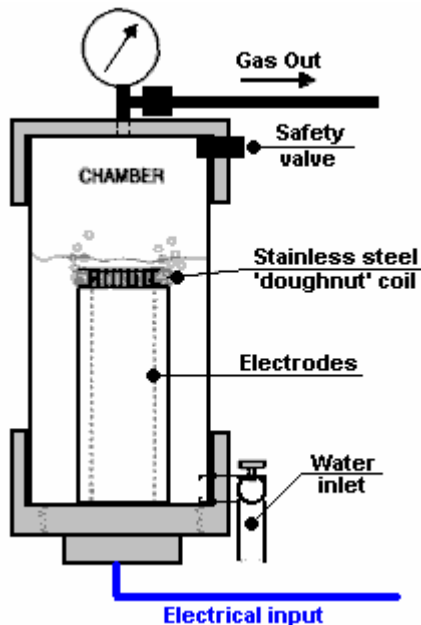

It is suggested that you use a section of 4" PVC waste pipe with a threaded screw-cap fitting on one end and a standard end-cap at the other. Make sure to drill-and-epoxy or tap threads through the PVC components for all fittings. Set and control the water level in the chamber so that the pipe electrodes are well covered and there is still ample headroom left to build up the hydrogen/oxygen gas pressure. Use stainless steel wires inside the chamber or otherwise use a protective coating; use insulated wires outside. Ensure that the epoxy seals are perfect or alternatively, lay down a bead of water-proof silicone sufficient to hold the pressure.

The screw fitting may require soft silicone sealant, or a gasket. Its purpose is to maintain the pressure in the cylinder and yet allow periodic inspection of the electrodes. Make sure that there are no leaks and you will have no problems. Make sure you get a symmetric 1.5 mm gap between the 2 stainless steel pipes. The referenced literature suggests that the closer to 1 mm you get, the better. Check that the chamber water-level sensor is working correctly before you epoxy its cap in place. Make your solder connections at the wire/electrode junctions nice, smooth, and solid; then apply a waterproof coating, e.g. the epoxy you use for joining the pipes to the screw cap. This epoxy must be waterproof and be capable of holding metal to plastic under pressure.

The suggested circuit for the reaction chamber water-level pump control is:

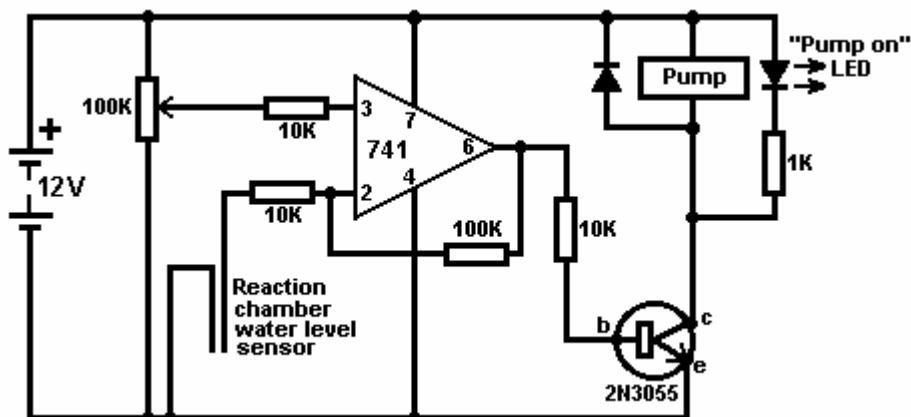

Hydrogen from Aluminium.

Since 2003 Rothman Technologies of Canada have been running a 12 HP petrol motor on hydrogen produced by a chemical process. This is a cheap process in which metal is consumed and so, although of great interest, this is not a 'free-energy' engine. A recent patent application by William Brinkley proposes a system where aluminium pipes are consumed by a 25% solution of Potassium Hydroxide heated to 180 degrees Fahrenheit. William remarks on the non-polluting nature of the system, but this is not really so in that a very large amount of energy has to be put into producing the aluminium metal in the smelting and refining process, and the pollution is just moved from the end user to the industrial plant, and much more importantly, the aluminium oxide produced is said to be highly toxic and cause a wide range of serious illnesses including Alzheimer's, although I have seen this disputed. Francis Cornish of the UK has a system where electrolysis of water is combined with a chemical process consuming aluminium wire. The system works well, but I have reservations about using consumables which tie you to industrial manufacturing, also concerns about the reliability of mechanical feed systems when they are being used by non-technical people (most car drivers). There is also the issue of removing and recycling the chemical residue generated by the process.

I personally am not keen on chemical processes and I do NOT recommend that you construct anything based on the following description. However, it might be possible to adapt the Brinkley system so that it operates with no moving parts:

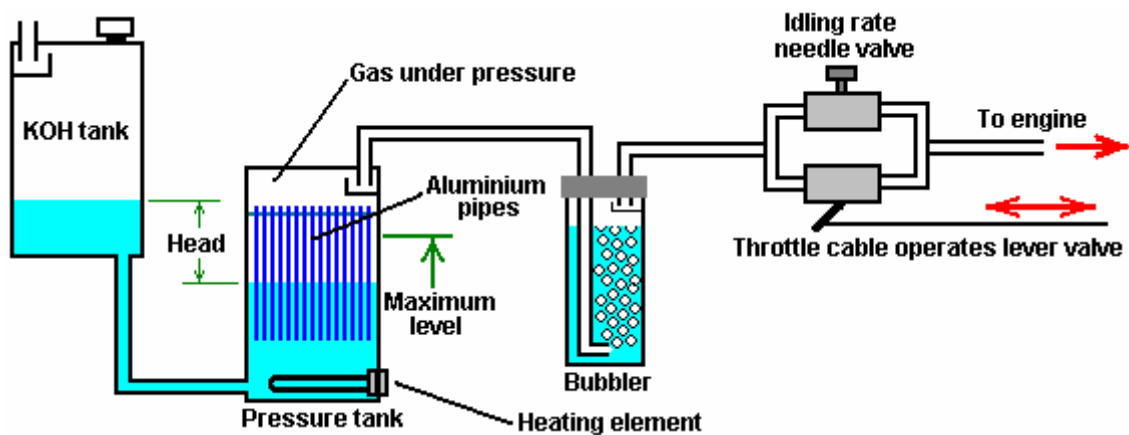

Here, there is a header tank containing a 25% mixture of Potassium Hydroxide (KOH) in water. This tank is positioned higher than the pressure tank where the hydrogen gas is generated and the venting pipe is protected by a baffle. The venting pipe should provide an outlet to the air outside the vehicle or building which contains the system.

Initially, the KOH solution in the pressure tank is heated by the heating element, but when the process gets started, it generates heat to maintain the chemical reaction. The gas generation then builds up pressure in the strongly-built pressure tank. The raised pressure pushes some of the KOH solution back into the header tank, against gravity. This reduces the area of aluminium exposed to the KOH solution and reduces the rate of gas production. This effectively creates an automated gas production rate control which has no moving parts.

If the rate of gas taken by the engine increases, that lowers the pressure in the pressure tank, allowing more KOH solution to run into the pressure tank, increasing the rate of gas production. When the engine is stopped completely, then the KOH solution gets pushed into the header tank until all gas production stops, as shown here:

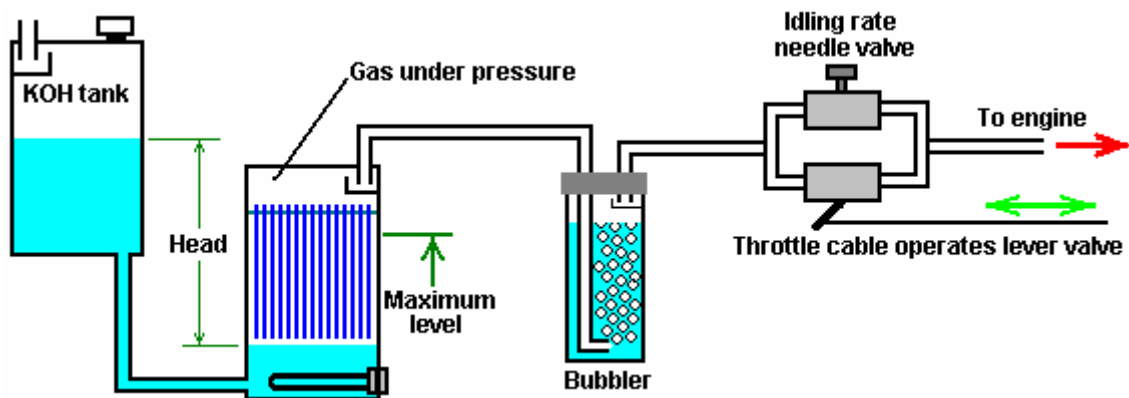

This looks as if the pressure tank is under considerable pressure, but that is not so, as the header tank is open to atmospheric pressure. I have concerns about controlling purely chemical processes rapidly enough for practical use. The above system would be more suited to a fixed engine, such as an electrical generator, where the gas requirement does not fluctuate greatly. The KOH tank shown above should be large enough to contain all of the KOH solution in case the gas production just does not stop when it should. The vent from the header tank should be capable of venting excess hydrogen with no possibility of it ponding on a ceiling and forming an explosive mixture with air. As far as I am aware, the above system has never been constructed and it is just shown here for discussion purposes.

Only 5 pounds per square inch of pressure is needed for electrolyser systems to feed a car engine satisfactorily, so a relatively low pressure is quite satisfactory, provided that the piping is of reasonable internal diameter. It should be remembered that the car engine will be applying a slight vacuum through the bubbler. As with all of these systems, it is vital that at least one bubbler is used between the gas production and the engine, to guard against flashback from the engine ignition if faulty ignition should occur. All bubblers should have a tightly fitting pop-off cap which can ease the effect of an explosion, and they should contain only a small amount of gas. The method of connection to the engine and the necessary timing adjustments are shown and explained in Chapter 10.

Francois Cornish Hydrogen System.

The method of using aluminium for a fuel in an on-demand hydrogen system for vehicle propulsion has been presented in detail by several people. One of the best known is the 1987 US Patent 4,702,894 by Francois Cornish, where he uses a feed mechanism for aluminium wire to maintain an underwater electrical arc which raises the water temperature high enough to make the aluminium react with the water. The rotating drum is made of aluminium but as it has a much larger thermal capacity than the aluminium wire being fed towards it, the drum temperature is much lower than that of the wire. As a result of this, the wire reaches the temperature required to make the aluminium react with the water. The chemical reaction releases hydrogen and converts the aluminium wire to aluminium oxide powder, which settles on the bottom of the tank, passing through a grid just above the bottom of the tank.

The bubbles of hydrogen gas released by the reaction tend to stick to the rotating aluminium drum, so a wiper blade is provided to sweep the bubbles off the drum. The bubbles then rise to the surface of the water and are directed into the gas collection chamber by a funnel located above the arc. If the engine demand drops and the pressure in the gas collection tank rises, a sensor located in the tank causes the wire-feed control electronics to stop the wire feed which cuts off the gas production.

At first glance, a system like this appears to have limited appeal. It uses aluminium wire which requires manufacturing by a process which uses substantial amounts of energy and while a vehicle using hydrogen produced by this method will generate very little pollution, the pollution occurs at the point of manufacture. Also, the device uses a mechanical wire feed and any device of that nature will need regular maintenance and may not be 100% reliable. In addition, the aluminium oxide powder will have to be cleaned out of the generating tank on a routine basis.

But, having said all that, the system has some very significant advantages. It does not use any fossil fuel (directly). It can be readily installed in a vehicle and the consumption of aluminium wire is surprisingly low. Figures quoted indicate that typical consumption is of the order of 20 litres of water, plus one kilogram of aluminium used to cover 600 kilometers distance (1 pound per 170 miles). This is probably a good deal cheaper than using fossil fuel to drive the vehicle. However, the aluminium oxide produced by this system is

a serious pollutant as it is **highly toxic**, producing a wide range of serious illnesses, including Alzheimer's. The system is set up like this:

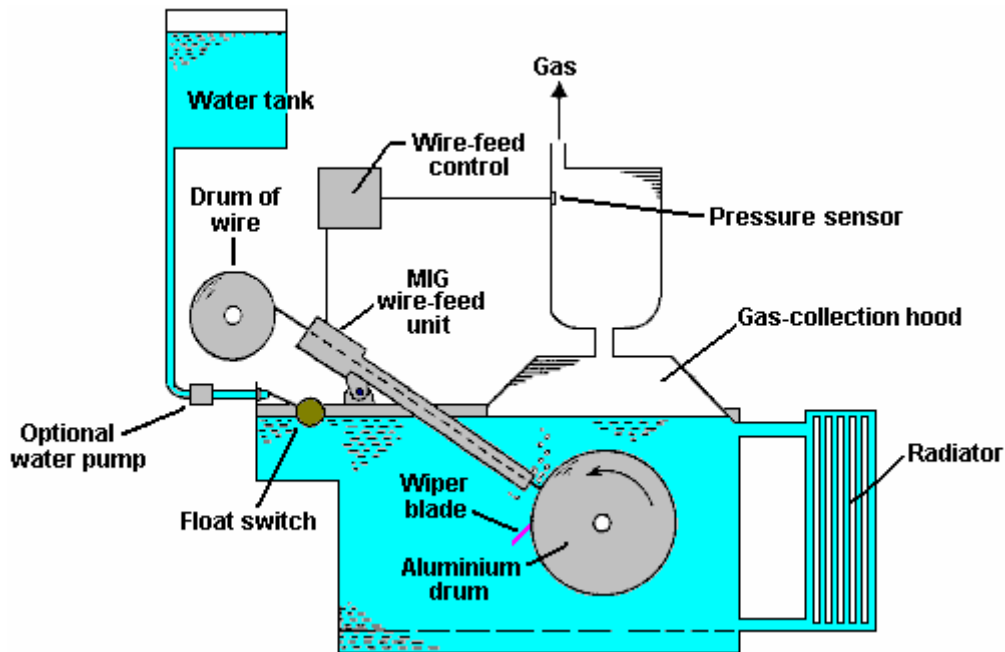

Another system of interest is the self-powered electrolysis system of the 1992 US Patent 5,089,107 granted to Francisco Pacheco where sacrificial anode plates of magnesium and aluminium are placed in seawater opposite a stainless steel cathode. Electrical power is generated and hydrogen produced on demand. There is also surplus electrical power available to run a standard electrolyser if so desired.

An Ultrasonic System for Producing Hydrogen.

I have been told (by a rather doubtful source) of a very high-performance water-splitting system which produces enough hydroxy gas to power a vehicle engine while only drawing 3 milliwatts at 3 volts which is a mere 9 milliwatts of power. I have never seen one of these units, and I have no evidence that the system works, other than word of mouth, so please treat the following entry as just a suggestion rather than a matter of hard fact.

The system is so interesting and simple that it is very attractive. Basically, you have two stainless steel pipes placed in a bath of tap water:

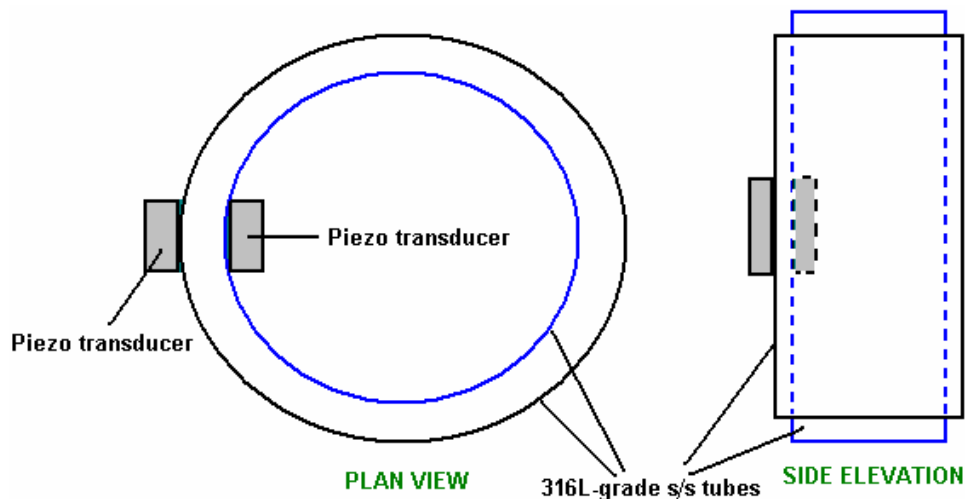

The objective is to get two stainless steel tubes resonating together at the same frequency. That is, they should both produce the same “musical” note when suspended on a thread and tapped. As the inner tube is smaller diameter, it will have a higher note than the larger diameter tube if they are the same length, so for them to match, it would be necessary for the inner tube to be longer, or the outer tube have a slot cut in it as Stan Meyer did and which is discussed in Chapter 10.

The piezo transducers are presumably glued to the cylinders, perhaps as shown above, and they are fed with a 2.24 MHz signal. The tubes need to resonate with the electronics signal, so they are ground down very slowly and carefully until they do resonate. This will presumably be at a much lower harmonic of the electronics signal, one in the standard ultrasonics range. Presumably, there will be three spacers top and bottom, maintaining the gap between the tubes. If the frequency were down in the mains region of about 50 Hz or 60Hz, then the device would just act as a water heater of the type designed by Peter Davey. At ultrasonic frequencies, the result is quite different as cavitation bubbles form in the water. A highly respected textbook on ultrasonics points out that these cavitation bubbles have a positive charge on one side and a negative charge on the other side and these charges cause electrolysis of the water surrounding the bubbles. Lots of bubbles - lots of hydroxy gas produced. So, background theory supports the possibility of this device working, however, I am not aware of anyone who has attempted to replicate it.

What we have not been told is:

1. The size, length and thickness of tubes which work well.
2. The gap between the tubes.
3. The specific transducers used in the prototype.
4. What type of spacers were used.
5. Where and how the transducers were fixed to the cylinders.

However, even without this information, this could be an interesting investigation project using absolutely minimal power at trivial voltage levels.

Valeri Ivanov’s Motionless Generator.

There are other devices which are very close to the MEG construction. One of these was displayed on a Bulgarian website and it has been translated into English on the web page which is located at <http://www.inkomp-delta.com/page7.html>, put up by Valeri Ivanov in 2007. Valeri lives in Elin Pelin, Bulgaria and his motionless generator has COP=2.4 performance. Videos: <http://www.youtube.com/watch?v=7IP-buFHKKU> and <http://www.youtube.com/watch?v=npFVaeSbk1Q> are for his design, and the forum members at <http://www.overunity.com/index.php?topic=4300.135> have been attempting to replicate his device.



It is shown that an effective device can be constructed from a permanent magnet, a toroid and a laminated iron yoke. The arrangement is displayed like this:

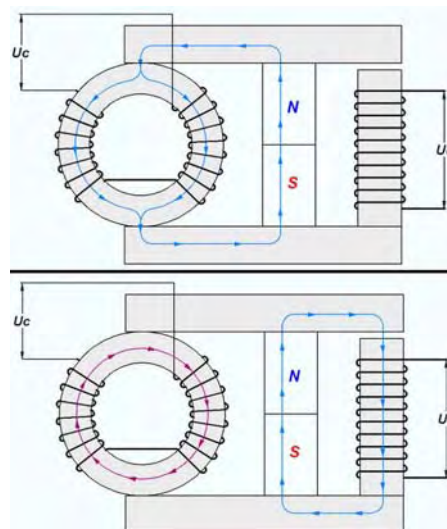

When the input coil is pulsed with an input voltage, it causes a flux reversal in the frame around which the output coil is wound, generating an electrical output.

There is another forum related to this and the better known MEG of Tom Bearden's which can be found at http://tech.groups.yahoo.com/group/MEG_builders/message/1355 where that particular message states that Valeri's device can be made to work at frequencies as low as 50 Hz and can use standard laminated iron frame components and produces Coefficient Of Performance figures up to 5.4 (that is, the output power is more than five times the input power). A demo video is at <http://inkomp-delta.com/page10.html> but not in English.

The "MEG" Motionless Electricity Generator.

Tom Bearden, Stephen Patrick, James Hayes, Kenneth Moore and James Kenny were granted US Patent 6,362,718 on 26th March 2002. This patent is for an electromagnetic generator with no moving parts. This device is said to be self-powered and is described and illustrated on JL Naudin's web site at <http://jnaudin.free.fr/meg/megv21.htm> where test results are shown. While this device has been claimed to have a greater output than its input and an output five times higher than the input has been mentioned, I am not aware of anyone who has attempted to replicate this device and achieved a COP>1 performance, and so, for that reason, it is described in this section describing devices which are unlikely to be worthwhile for the home-constructor to attempt to replicate.

The "Motionless Electromagnetic Generator" or "MEG" consists of a magnetic ring with output coils wound on it. Inside the ring is a permanent magnet to provide a steady magnetic flux around the ring. Superimposed on the ring are two electromagnets which are activated one after the other to make the magnetic flux oscillate. This is very much like Floyd Sweet's "VTA" device.

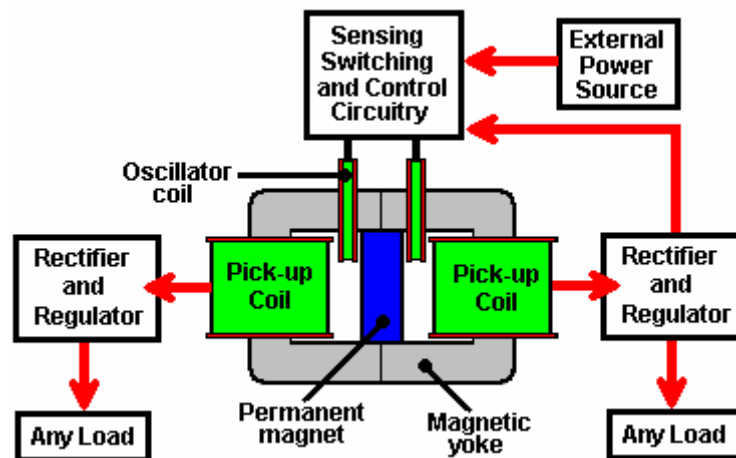

The external power source shown above is intended to be disconnected when the circuit starts operating, at which time, part of the output from one of the pick-up coils is fed back to power the circuit driving the oscillator coils. The circuit then becomes self-sustaining, with no external input but with a continuous electrical output.

If you should construct one of these, please be warned that it should **not** be started up unless there is an external load across the pick-up coils, otherwise dangerous, potentially lethal voltages can be produced. Don't get yourself killed or injured - please be very careful.

A re-worded excerpt from the patent for this system, is in the Appendix and it gives the construction details of the prototype: dimensions, number of turns, materials used, drive frequency, monostable pulse durations, etc. The prototype produced two outputs of 48 watts for one input of 12 watts. This allowed the input power to be taken from one of the outputs, while that same output was powering other loads.

This device is essentially, a custom-built transformer with two primary windings (the oscillator coils) and two secondary windings (the pick-up coils), with a permanent magnet inserted to create a standing magnetic field through the yoke (frame) of the transformer. However, a permanent magnet has two separate energy streams coming from it. The main field is the magnetic field which is very well known. It normally flows out in every direction, but in the MEG, a very good conducting path is provided by the frame of the device. This

traps the magnetic energy flow and channels it around inside the frame. This prevents it masking the second energy field which is the Electrical energy field. With the magnetic field moved out of the way, it is now possible to tap this energy field for additional power output.

The MEG looks like a very simple device, but in actual fact, it is not. To act as a successful device with a Coefficient of Performance (COP) over 1, where the input power which is provided is less than the useful power output of the device, then Tom says that the frame needs to be made from a nanocrystalline material. This material has special properties which give the MEG it's exceptional output.

Care has to be taken with this device as the output power can be so high that it can burn the insulation off the wires and destroy the device if the output power is not controlled carefully. The output power is normally limited to a COP of 5.4 for practical reasons. If the necessary input power is taken from the output power via a rigorous control circuit which prevents runaway, then the device can provide output power while no outside input power is needed.

The output power is controlled by the waveform being sent to the oscillator coils. The power is controlled by the exact shape of the "square wave" drive:

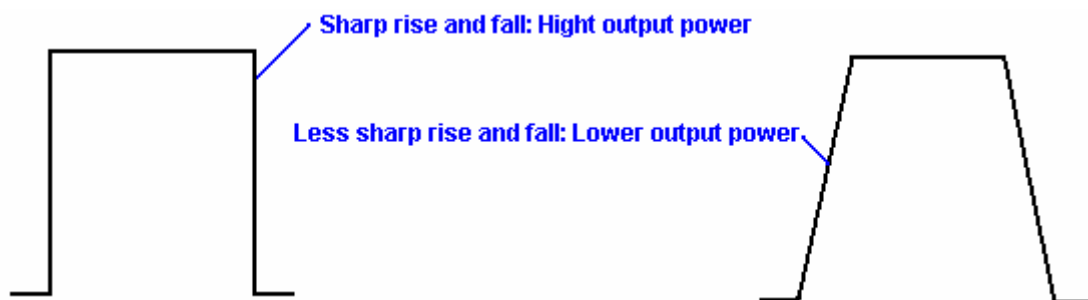

This waveform is adjusted carefully to keep the COP down to 5.4 for safety sake. The waveform is also adjustable for frequency and Mark/Space ratio.

As it is some years since this device was patented, the question can be asked as to why it is not in production and offered for sale everywhere. The reason is that the MEG is a laboratory prototype which needs careful adjustment and tweaking. It has been replicated by others and it's performance verified as being $COP > 1$, but it is not yet ready for production where it is necessary to have the design enhanced to the stage that it can be assembled in a factory and work immediately without the need for manual adjustments. That development is in hand and may be completed in the next year or two.

Some further explanation is in order. The MEG has an overall efficiency, well below 100% in spite of having a Coefficient Of Performance well in excess of 1. The COP of 5.4 mentioned earlier is an arbitrary figure selected by the designers to prevent the insulation being burnt off the output wires. The actual maximum output is almost unlimited, certainly a COP of 100 is perfectly possible, but quite unnecessary in practical terms.

If a standard laminated iron yoke is used for the MEG, it will never have a $COP > 1$ as input power will be needed to make it operate. The magnetic flux from a permanent magnet consists of two components. One component is rotary and it spreads out in every direction. The second component is linear and it gets swamped and hidden by the rotary field. If a toroidal yoke wound with an input winding over its whole length is used, then that traps all of the rotating magnetic field inside the toroid. The snag is that this requires considerable input power to energise the toroidal winding. The big advance with the MEG is that the inventors have discovered some standard off-the-shelf nanocrystalline materials which have the property of trapping the rotational magnetic field inside a toroid formed from them, **without** the need for any energising coil. This is a major boost to the functioning of the device.

Now, with the rotational magnetic field trapped inside the toroid, the linear field becomes accessible, and it is a very useful field indeed. It is electrical in nature. In actual fact, magnetism and electricity are not two separate things, but instead, they are different aspects of the same thing, so both should really be referred to as "electromagnetism". Anyway, the linear field is easy to access once the rotational field has been removed. All that is necessary is to pulse it sharply. When that is done, real electricity is introduced into the MEG from the surrounding environment. The sharper the waveform, the greater the additional electrical input becomes. This is what makes the MEG have a COP of say, 5.4 which is a practical working output. If the output is then manipulated to provide the input power needed for the pulsing, the COP effectively

becomes infinite as you do not have to provide any power to make it work and you have a substantial power output. The power output divided by the power input you have to provide to make the device operate, gives the COP rating, so any output divided by zero input, always gives infinity.

Dave Lawton has experimented with the MEG arrangement, using a professionally constructed custom laminated iron yoke. He found that using the standard arrangement, he found no difference when he removed the permanent magnet. Testing various configurations, he found that the most effective set-up for his components is:

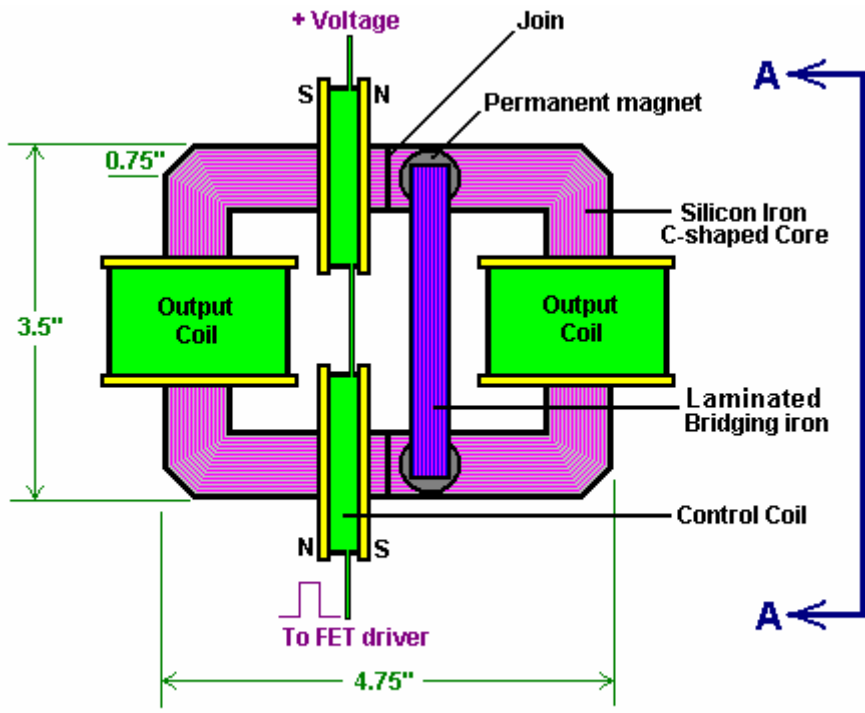

SIDE VIEW

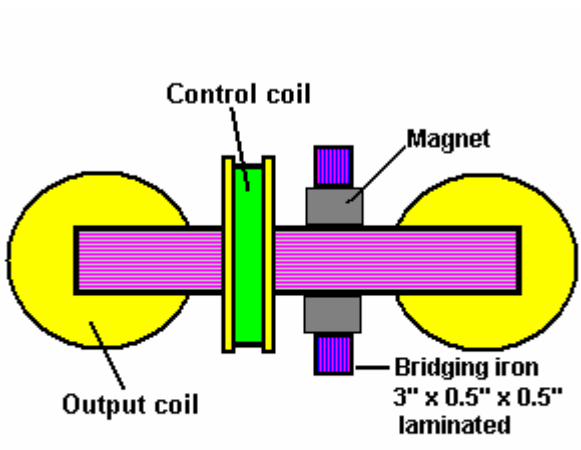

TOP VIEW

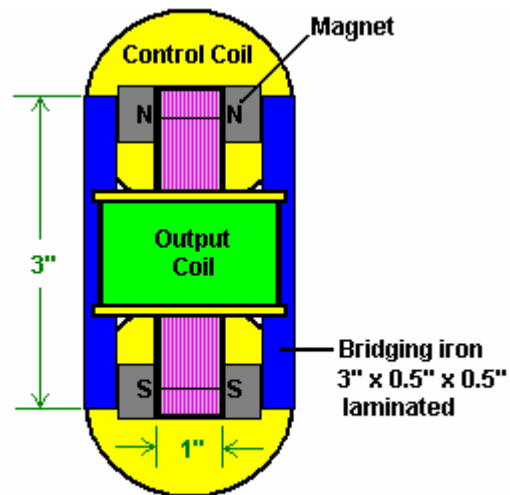

SECTION A-A

Here, the drive coils are both put asymmetrically on one side of the frame and wired so that their pulses complement each other. Then two pairs of button magnets are placed on the other side of the centreline, each side of the yoke, and bridged together with two straight vertical sections of laminated iron bar. This arrangement is sensitive to the exact position of these magnets and tuning is achieved by moving the group of four magnets and two bars (effectively two "horseshoe" magnets) slightly left or right to find the optimum position. Introducing or removing these magnets then made a considerable difference to the operation of the device.

While most people find it very difficult to get COP>1 operation from the MEG, I am reliably informed that WITTS have succeeded in producing self-powered replications. There is, on the web, an exceptionally well-written presentation by Jacco van der Worp entitled "The Hitchhiker's Guide to the 'Free Energy' MEG" at <http://yowusa.com/scitech/2002/scitech-2002-06a/1.shtml> and it explains how and why it can work. By kind permission, it is reproduced here:

A Hitchhiker's Guide to the "Free Energy" MEG

YOWUSA.COM, 25-June-02

Jacco van der Worp

Foreword by Marshall Masters

This article by Jacco van der Worp a Dutch physicist, explains the "free energy" Magnetic Energy Generator MEG simply, in layman's terms. I worked closely with Jacco on this project and sent a polite request to Lee Kenny, one of the MEG principals for assistance. His quick response was controlling and reeked of paranoia. "You are NOT AUTHORIZED by MEL to publish any information regarding the MEG." (*Readers can view and comment on the full text via the YOWUSA message board post, MEG -- Masters and Kenny.*) At first, his paranoid reply puzzled me, but as we further investigated the MEG we came to understand the paranoia and it chilled our blood. Perhaps this particular genie should be left in the bottle.



My first reaction to Kenny's suppressive controlling behavior was to shoot back a reply reminding him that there is a funny little piece of paper called The Constitution. After that, the urgent paranoia in Kenny's response continued to task me.

An obvious and simplistic explanation is that Bearden et al. are busy subscribing to Yachting Magazine and setting up bank accounts in offshore tax havens for their new to be wealth. The problem is that is too simplistic an explanation, because after working with engineers for twenty-five years I've learned to recognize a knee-jerk paranoid reaction when I see one. Kenny's reply was quintessential a knee-jerk paranoid reaction. Perhaps, I would have reached this conclusion early on, were I not so enamored with the MEG technology. But as dug deeper, I found more tangible reasons for Kenny's paranoia.

The process of invention is a passionate one. At the end of the process are the hopeful financial rewards, but for something as complex as the MEG there is an equally large reward -- peer recognition. "Damn your eyes, but you did it." In this heat of invention the post reality dimensions are discussed but at a lower level and with less emphasis. I believe this is what may have happened to the MEG inventors. They simply got so carried away with the passion of invention that it clouded their view beyond the moment they would receive their patent, which in turn would embrace their paradigm shifting theories with plausibility.

However, once the patent was issued, the types of articles one would expect to see in magazines like Popular Science and Popular Mechanics failed to materialize. Further, what was made available by Bearden et al. was such geeky technobabble that it usually sails over the head of the average man. I now believe there was a reason for this.

The MEG opens a doorway into a new future, filled with new applications that will build upon the fundamental concepts of the MEG. Like the nuclear genie America unleashed upon Japan, the MEG genie offers us both a new and better world as well as a dead world all in the same breath. I believe this explains Kenny's paranoia. Now that he and his fellow MEG/MEL partners are looking at the practical applications of their invention they are starting to see it from "outside the box" as they say in the computer business. So what could they be seeing that makes them want to control the flow of knowledge about this new invention?

While the focus now is on the "free energy" application of MEG technology, its ability to interact and deform the space time continuum offers an alarming new range of applications to include: Weapon of mass destruction, interstellar space drive and time machine engine. And that is only the beginning of the hypothetical possibilities that could emerge from this paradigm shifting invention.

However, before we this genie is let out of the bottle, our elected representatives and all of us in the mainstream need to understand the MEG a little better. That is the goal of this superb article by Jacco van der Worp.

YOWUSA.COM
Marshall Masters, Publisher

A Hitchhiker's Guide to the "Free Energy" MEG

This fourth article in a YOWUSA series on the Motionless Electromagnetic Generator by Tom Bearden et al., now under patent, discusses this groundbreaking technology in non-technical layman's terms as opposed to delving deeply into the physical principles behind the MEG. Once you have finished reading the article, you will have a general idea of how the MEG works and why its inventors call it a "free energy" machine.

For those with bolder interests in the precise formulas and equations describing the MEG, those working on the project have already published several technical articles on the Internet. The best of these is a 69-page PDF file called [The Motionless Electromagnetic Generator: Extracting Energy from a Permanent Magnet with Energy Replenishing from the Active Vacuum](#). This document lays out the most basic principles used for the MEG with some graphics added in.

Getting to know the MEG

The MEG represents a revolutionary approach to generating energy in our ever more demanding economy. However, it may also become a huge financial threat to big energy companies, as Marshall Masters outlined in his article [Bearden's Free Energy MEG Destined For Chapter Eleven](#).

However, if the MEG grows into its destined role, it will conquer the market. It will do so by providing mankind with a durable and above all clean source of energy, which so far no other source of energy has achieved at an affordable price.

For the common person, the MEG is an obtuse technical wonder and understanding why it works requires one to dive headfirst into what seems to be a bottomless pool of technobabble. However, if we pare the issue down to five basic technological terms, we can create a basic understanding of the MEG.

In a MEG device there are five basic terms playing an important role in making it work. They are (energy) flux, efficiency, capacitance, magnetic field and shielding. This article will attempt to explain each MEG term simply, using everyday examples. After the basic explanation, we will explore a full analogy in the form of a rain barrel.

Flux



Flux, or energy flux to be more precise, is essentially a by-product of energy creation. For example, an automobile engine uses a mixture of gasoline and air to power the car. Older engines in particular were not extremely efficient in burning all of this mixture and the by-product is the smog that comes out the tailpipe of the car.

Modern car engines are more economical; less unburned gasoline goes out their tailpipes. However, even the most efficient cars on the road today still push unburned gasoline out the tailpipe. On top of that, part of the heat generated by the burning of the gasoline inside the engine also leaves that way. In a manner of speaking, the smog that comes out of your car's exhaust is like flux. It is a by-product of the process of creating the energy needed to make your car travel down the road.

Flux and Efficiency

Before the oil embargo of 1973, American car designers largely ignored the issue of flux by building cars with larger engines to go faster. Consequently, this fuel economy suffered from the embargo. However, in 1973 the price of fuel did not make this an important issue. Once the fuel price rose after 1973, American auto manufacturers began losing sales to foreign manufacturers who were building more fuel-efficient engines.



Efficiency

We define efficiency as the useful application of energy flow. This means that if we build a more fuel-efficient engine, it will send less unburned fuel out the tailpipe and thereby increase the number of miles we can go on the same amount of gasoline.

The part we call useful here is the energy of the burned gasoline whose heat is used to move our car. That is what we aimed for, that part divided by the total energy that could be produced from the amount of gas we used, is called efficiency.

Efficiency and Unity

Since 1973, the goal of auto manufacturers is to use the available energy in gasoline as much as possible. The most they can hope for is what is called unity. Unity means that a system can use 100% of the energy input into it. In this case, that would be the energy stored in the gasoline to generate the desired output, the output in this case is the horsepower our engine delivers to move our car down the road.

No matter how efficient the designs are in pushing toward unity, the most a system can hope to achieve with present technologies is around 30% efficiency, which is some 70% short of unity.

Unity and Closed Systems

When we commonly think of unity (100% efficiency), we also tend to think in terms of closed systems. A closed system is a system that is completely isolated from the rest of the world. In a manner of speaking, an automobile engine is a closed system. The energy released from the burning of the gasoline to extract its energy is either captured to power the car or blown out the tailpipe as wasted flux. Likewise, you continually reduce the amount of gasoline in your tank as you drive down the road. The total amount of energy that is either still stored in unburned gasoline or is moving your car along or is leaving the tailpipe as waste flux is constant.



The essential point to keep in mind about a closed system is that it does not draw energy from the environment around it. On the other hand, an open system does draw energy from its surroundings.

Closed Systems and Open Systems

If we were to create automobiles with open systems, what would they look like? They would have the same engine, but an automobile with an open system would for example have a mast and a sail.

In this case, the driver would use the automobile engine to raise and lower the sail. The raised sail completes an open system by capturing motion energy from the wind and using it to propel the car down the road (provided the wind is with you.)

Once you have raised the sail, you can make the car go forward by angling the sail to the wind. To slow you can position the sail in line with the direction of the wind thereby neutralizing it as an active, open power system. Once you raise the sail, you do not need the car's engine for propulsion.

The essential point to keep in mind about an open system is that it draws energy from the environment around it like the sail on our modified car. In addition, it is controllable in that you can turn it on and off, just like a closed system.

Open Systems and the Coefficient of Performance (COP)

Because the auto sail is not limited to the energy of the fuel in the gas tank (which can never exceed unity or 100% efficiency), an open system (portrayed here by the auto sail) can in fact exceed unity. In other words, it can obtain more than 100% efficiency from the energy system it is interacting with, which in this case is the wind. So how do we measure systems than can achieve more than unity?

The term Coefficient of Performance (COP) compares the amount of energy input into a system versus the usable amount of energy output by the same system. For example, if using the engine in our auto to raise the sail requires one unit of energy and that when the sail is raised it generates or gathers 8 units of wind motion energy, the Coefficient of Performance is 800%. Another way of expressing this is 8:1, where 8 is the useful energy available and 1 is the amount of energy inserted into the system to trigger the generation of usable energy.

Coefficient of Performance and Capacitance

In our car example we used a sail to propel our car to achieve an 8:1 COP. Could this work with larger systems? For example, could it work with trucks as well? We already know that sails were used to propel huge wooden sailing ships centuries ago.



Let's go back in time to sailing ships for a moment. The builders of these great ships knew that the more and bigger sails they added to their ships, the faster they would go. However, great expanses of water surround that ship on the ocean. With this in mind, let's see how this applies to using sail power to propel cars and trucks.

Because cars and trucks travel in close proximity to each other and in the same direction on a highway, the amount of wind energy available in the open system must be divided amongst the various vehicles. Consequently, those in closest proximity to the wind direction will bleed off wind power from those ahead of them. In essence, they literally steal each other's wind.

In terms of capacitance, the essential concept here is that open systems may not be unlimited systems. In the case of our auto and truck sails, the proximity and number of sails accessing the same open wind system for energy will drain the open system. In other words, even if an open system is free, capacitance tells us that there is only so much of it to go around.

At this point, we've discussed some general terms used with the MEG. Now we're ready to discuss terms that are more specific to the MEG, beginning with fields.

Fields

In very simple terms, a field is any mechanism that serves as a means to an end. In the car example, we used a sail as our field, in that it gathered energy from the open wind system.

Unlike the sails we use as fields to capture the energy we need to propel our cars, in terms of the MEG, we must use something called a magnetic field.

Magnetic Fields

In the case of the auto sail, we used our sail as a field to pull energy from the open wind system around us so that we can propel out autos. The energy we needed was stored inside the wind.

With the MEG, the energy source we need to tap is not the wind, but electromagnetic forces of the universe that are just as omnipresent as the wind is on Earth, if not more so.

What the sail and the MEG have in common concerning the fields is that they must control their fields in order to prevent undesirable side effects.

Looking at our auto sail example, we attach lines to the sail and boom to control the trim of the sail so that it captures as much energy as possible without overstressing the sail and causing damage. Hence the popular sailing term, trimming the sails. Likewise, untrimmed sails can be dangerous, presenting a hazard to systems such as the boom and mast, or to the sailor if the wind moves the sail and boom violently across the ship, upsetting the balance of the ship.

In a manner of speaking, the MEG uses something called shielding to achieve the same thing as controlling the trimming of the sail if you will. Without it, violent effects may damage its surroundings.

Magnetic Fields and Magnetic Shielding

With the MEG, the magnetic fields are very powerful and must be controlled tightly at all times in order to prevent them from creating havoc in the space around them. This is why the MEG needs to use magnetic shielding.

The most important concept of magnetic shielding is that it serves as a safety control for magnetic fields by containing and minimizing their negative effects.

The Rain Barrel Example

At this point, we've covered all the bases with the exception of the magnetic vector potential, which forms the crux of the MEG theory. To help you to understand the complexity of this concept, let's first review what we have covered up this point within the context of a simple rain barrel system. The reason for this is that one may understand the MEG magnetic vector potential more easily from a systemic viewpoint.

Flux

Some of us may have tried the following as kids or even later in life. If we take a barrel filled with water (or a gas tank filled with petrol) and we want to take some of that out, we do not have to suck it all out ourselves.

We take a piece of hose; simple garden hose will do, and stick it into the reservoir from which we want to take the liquid. On the outside, we lower one end of the hose a little lower than the opposite end sitting inside the tank. Then we gently suck on the hose (let's keep to water from here if only for the sake of taste) and the fluid will start to flow. Once it does, it will continue to flow until the other end of the hose inside the tank is no longer submerged. Therefore, with only a little effort we move a lot of fluid out.

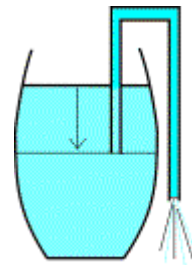

The mechanism that makes this work is called the capillary effect. In other words, the weight of the column of fluid in the hose with a height equal to the difference in height of the two ends of the hose is providing the force that is needed to keep the fluid moving. However, what we do know is that the water barrel will run empty if we just pour it all out.

On the other hand, the MEG draws energy from a 'barrel' that fills itself right back up! So it never runs empty! If you repeat the stimulated energy flow out of the MEG, energy flux will come out of it continually; it will not run dry like our rain barrel.

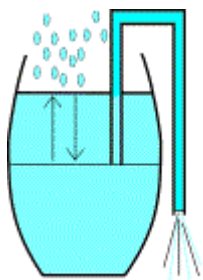

Therefore, a proper way to describe the MEG therefore in terms of this example would be a rain barrel into which more rain would fall the instant that that one draws water from it. Once you start the water flowing through the hose, the rain starts falling into the barrel and replaces the water you're pulling out at a similar pace.

For this reason, a MEG-style water barrel will never run empty and the water will flow forever out through the hose once you have brought it in motion because the MEG is an open system, which brings us to the next point of consideration, what efficiency vs. COP means for our rain barrel.

Efficiency and the Coefficient of Performance

For the purpose of our rain barrel example, the term "efficiency" can be defined by the amount of water we can pull from the barrel by drawing it into motion with the siphon hose.

With the closed system water barrel, we learned that a closed system is isolated from the rest of the world, so no rain comes falling in from above to replace what we're taking out. In this case the best we can do is position the hose at the very bottom of the barrel on the inside and while letting it hang even lower on the outside. By doing this, we can siphon all of the water out of the barrel, which gives us maximum of 100% of the water. This 100% of efficiency is called "unity."

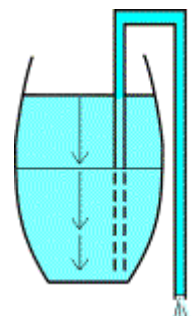
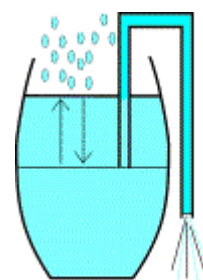

Keeping the unity of our closed rain barrel system in mind, let's shift back to our open system variant.

The moment we begin to siphon water from the open system rain barrel, fresh rainwater falls in through the open top of the barrel. No matter how much water we siphon from our open system water barrel, enough new rain falls through the top to replace what we are taking about.

Therefore, put in motion a never-ending stream of water with our open system rain barrel we can obtain results greater than that of unity. This is what the Coefficient of Performance (COP) is about. We use it to express the output result, which is greater than what we put in. Ergo, the COP for the open system rain barrel can exceed unity (100% efficiency) whereas the close system rain barrel can only hope to achieve unity. So then, what happens if we increase the size of our rain barrel?

Capacitance

Aside from the direct effect of having more water by increasing the size of our water barrel and siphon hose, there are indirect effects as well and they need to be carefully considered.

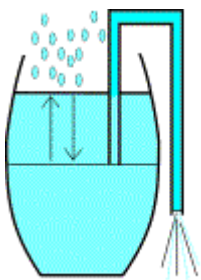

For starters, if we make our barrel bigger as well as our siphon hose what will that mean for us? Given that we'll be using a bigger hose to siphon out more fluid, we'll need a stronger suction force to begin with. We can do that simply (provided we have the lung power) without requiring a scaling-up of the entire system.

However, if we drain more water per second from a bigger barrel (e.g. the size of a lake) and we want it to keep running, it will have to rain harder to replenish the water that we take out and rainfall is bound to a natural limit.

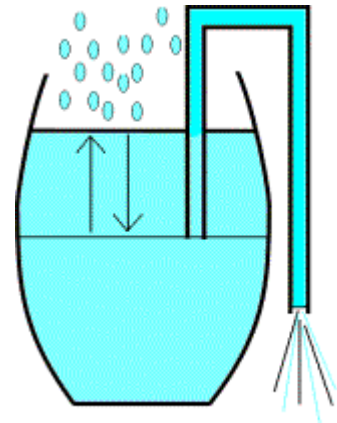

At a certain barrel and hose size, not even a tropical storm will provide enough rain to keep the water level up and the system will start to collapse. On top of that, a normal barrel stands on a support structure. The bigger the barrel, the harder it will be to find a place for it to stand and remain standing. Otherwise it might fall over or break. So, how do we keep our bigger barrel from coming apart?

Fields and Shielding

If the barrel gets really big (let's assume for a moment it is the size of Lake Superior) and we start siphoning water out of it at the pace of four times the total water flux of the Sault Ste Marie Canals, then the water level will take time to readjust for the water poured out. The most important field in action here is the siphoning process, powered by gravity, which results in the water flow out of our bigger barrel lake. (Yes folks, now we're talking at a planetary scale.)

Normally, water level is horizontal (allowing of course for the curvature of Earth on a larger scale). However, if the pace of siphoning gets high enough, the normal water flow will become incapable of correcting the level quickly enough.

A permanent difference in height of the water level from one side of the lake to the other will arise. In that case stopping the siphoning action will not result in an immediate stop in water flowing towards the siphoning point. A sudden stop in pouring from a lake-sized barrel will cause at least a small tidal wave. The bigger the level difference across the lake, the worse the tidal wave will turn out. Although that looks like another field in action in the big barrel system, it isn't. It is a self-correcting mechanism for the lake surface after it has been disturbed.

In simplistic terms, what this all boils down to is that the flow energy like the flow water through our water barrel system represents a field. As a field increases in size it can likewise destabilize in greater amounts as well. Therefore, if we wish to increase the size of our fields we must find ways to shield them from those things, which could destabilize them.



Fields and Shielding

If our normal-sized rain barrel overfilled with water it could start to leak. In such a case, we would need measures to prevent a gushing flow of rainwater from damaging the immediate surroundings in a flood.

On the other hand, with our lake-sized version of water barrel we would need dikes to surround our lake to keep it from overflowing onto the land around it.

This flooding finds its cause in a pace difference between the raining in and pouring out of the water. These dikes must of course be able to withstand small tidal waves that emerge due to the starting and stopping of the siphoning action. In very simple terms, this is called shielding.

Up to this point, we've covered the most essential concepts we'll need before we tackle the big one -- vector potential. This is an important yet complex concept but it goes to the very heart of what a MEG is why it can do what it does.

MEG Components and Layout

The picture below, taken from the abstract by Magnetic Energy Limited as it published on the Internet. (We've added the colored placeholders to make it easier to view.) This illustration shows the basic layout of a lab prototype of the MEG used to successfully demonstrate the theory.

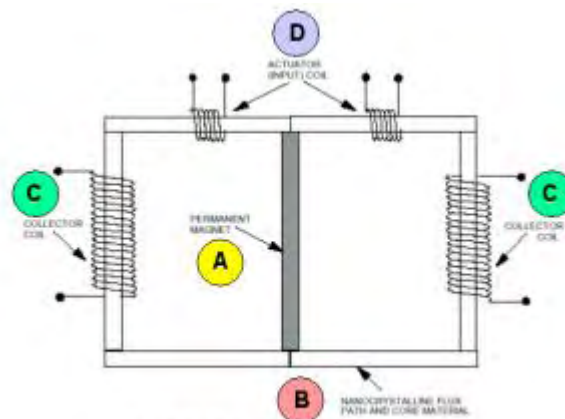
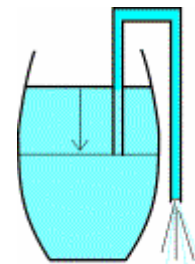

Figure 17. Diagram of laboratory test prototype.

- PERMANENT MAGNET (A): The most important element is the permanent magnet sitting in the middle of the schematic picture. The magnetic field lines come out of that bar magnet at the top and bottom side (in this picture). This magnet is what helps drive the entire machine.
- NANO-CRYSTALLINE FLUX PATH AND CORE MATERIAL (B): Instead of freely 'circling' from the North Pole of the magnet to the South Pole they enter a 'nano-crystalline flux path and core material.' That material captures all of the magnetic field of the permanent magnet, so that no magnetic field is present free in the air any more.
- COLLECTOR COIL (C): The collector coils are the points where energy can be tapped from the MEG.
- ACTUATOR (INPUT) COIL (D): The actuators are the points of input of energy to put the much larger amount into motion.

To compare it to the rain barrel, the actuators are your mouth drawing water through the hose. The collectors are the hose ends hanging out of the barrel that starts to pour once you've generated a capillary with your siphon hose. And finally, the magnet and the coil containing the magnetic field are the barrel reservoir containing the water.



How the MEG Works

Now we come to the crux of the whole system, the reason why it works in the first place. The driving force in our large, lake-sized rain barrel was the force of gravity. That made the water that falls at some distance away from our hose move towards the initial siphon point and in turn caused the water to run through the siphon. In this case, gravity is the restoring force of the water level of our lake-sized rain barrel as it makes the water level go horizontal again.

This force and the correction mechanism attached to it have an equivalent in the magnetic arena. That force is the magnetic vector potential. If we look at the MEG, we see that it converts an energy flux that was stored in such a vector potential outside a closed magnetic field path. (Whoa, wasn't that a mouthful. Let's break it down into more simpler terms.)

OK, So What is a Vector Potential Anyway?

To explain vector potential, we need to use something other than a rain barrel, but it must be familiar so why not the energy we use in our homes to run our computers, hairdryers, etc.

We all know about the electrical potential across the two wires of a wall outlet. This electrical potential is what makes a light bulb burn. If we're not careful with the outlet we could also find ourselves flat on our back as our family members frantically call for an ambulance. Thankfully though, the US, the electrical potential is 110 volts, which was chosen because it is not as lethal as the 220-240 volts standard found in most of the other countries in the world.

However, if we combine the numerical value of this electrical potential with a direction, we have a vector potential. In the case of our 110-volt outlet, if we change the direction from say the horizontal to the vertical, we can double our potential to 220 volts. Therefore, direction is important for the creation of any magnetic field; they all emerge from a magnetic vector potential where direction plays a critical role.

The following illustration compares the MEG with our rain barrel example for a very general layman's understanding of how the MEG works and why the magnetic vector potential is so important. (Please keep in mind a precise explanation would require an article several times the size of this one, so we'll just paint our picture with broad liberal brush strokes for now.)

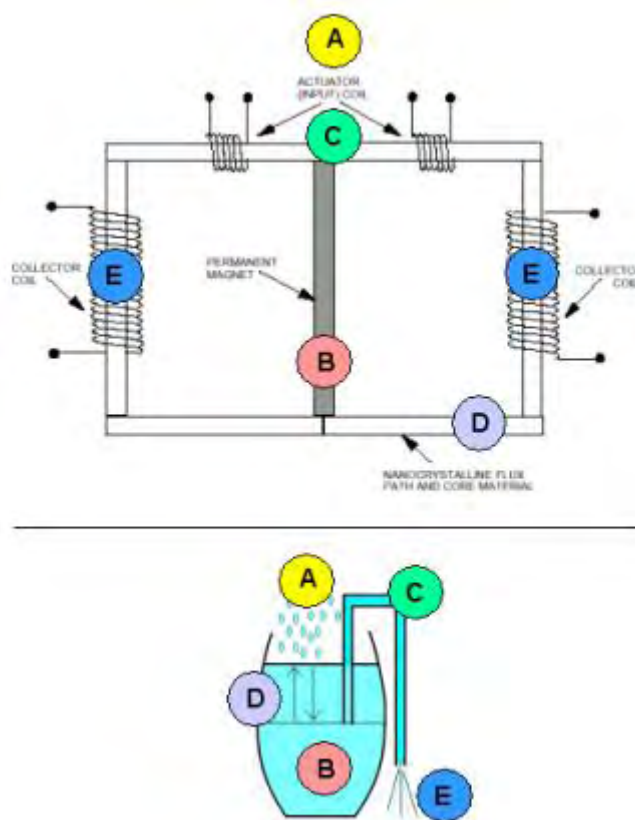

- (A) An outside reservoir waits until the system is brought into motion and then starts to work to restore the balance that is broken by sucking the siphon hose. For the rain barrel it is the rain filling the barrel back up, for the MEG it is the vector potential converting its energy into magnetic field inside the closed path.
- (B) This adds an extra field to the magnet field inside the closed loop.
- (C) In essence the actuators work like the siphon hose in our rain barrel example and by changing the direction of the water it creates an outside vector potential.

- (D) Consequently, the closed path starts to interact with the magnetic field inside, to compensate for the change in the situation. It gives energy to the magnetic field inside the closed path.
- (E) We can then tap that energy from the collectors and we find that more electrical energy comes out the collectors than the amount we put in through the actuators. So energy from the vector potential field outside the closed path is 'flowing towards the siphon' to correct the 'field level' again. If we lead part of this energy back into the actuators again, the rest of it is free flux! Free flux?

With the MEG energy flux actually becomes the result product or output instead of a waste by-product as with fossil fuel powered systems like car engines. What used to be waste is now useful output, just like today's electricity drawn from the net to light our houses.

In that respect, the MEG forms a new way of looking at energy flux and if you happen to install a MEG next to your home, it will require far less energy to provide you with far more electricity. Consequently, your energy costs will come down considerably.

Why the MEG is Commonly Misunderstood

The MEG uses an input energy flux to convert a far greater amount of thus far unusable energy flux into a controllable and more convenient form. This can leave some folks scratching their heads because this is a whole new twist on flux. For those who are familiar with the principles of conservation of energy this represents a paradigm shift in thinking that can defy years of heavily instructed thought about closed systems. And here is the rub. The rigid principles of conservation of energy apply only to closed systems such as automobile engines, whereas the MEG is an open system.

Because the MEG is an open system, it can turn flux into output because it is a system out of balance with the world around it and therefore constantly interacting with the environment around it! This way, it may result in a COP that is far greater than unity.

Another factor that makes it difficult for conventional thinkers to understand the MEG is that it does not use the Lorentz Gauge.

When Tom Bearden and his team of researchers discovered the principles behind the MEG when they chose to omit a commonly known calibration of an electromagnetic system, the so-called Lorentz Gauge.

The Lorentz Gauge is essentially a free choice of values for given parameters of an electrical system; this free choice makes mathematics simpler. At the same time however it discards a range of interesting (as it turns out now) solutions to a set of equations describing the same system. This range is the range of non-equilibrium states.

By keeping the MEG just off-equilibrium (out of balance) all the time, we can use it to pull a tremendous amount of energy out of a so far unusable reservoir into a convenient form. In essence, this is what the MEG is about.

Potential Problems with the MEG

We know that the MEG works, but it is also of interest to see just how much it can do. Most of you will likely be interested to know if a MEG can power a home. Can we scale it up without a limit, or could one such device even power a city?

The scale of many devices is only limited by practical design questions. The MEG needs a permanent magnet as well as a nano-crystalline material completely confining the magnetic field loops that leave this magnet. It also needs input and output coils. Electrical currents running through wires will produce heat, which will have to be dealt with at a high enough pace, but other than that, the potential size and productivity of the system is virtually unlimited. This type of generator should a priori be scalable to city-block level.

There are, however, possible side effects to its operation, which we want to take a closer look at before starting to operate a MEG for a city.

A few problems might exist for the MEG. Right now, it is uncharted territory, but we need to consider the possibility that above a certain level, the vector potential field cannot rearrange its energy fast enough for the working conditions to remain intact, thereby causing the MEG to fail. To fully illustrate this possibility, let's revisit some of the basic terms we discussed earlier in this article.

Magnetic Fields

The energy stored in the magnetic field and the vector potential field may interact with conducting materials outside the MEG as well, generating secondary magnetic fields and electric currents.

There's more. As energy leaves its surroundings, new energy comes flowing back in. We do not know if the pace of that is bound to a limit. It may have side effects that are currently unknown to us. Some pessimistic reactions have even spoken of an alteration of the space-time continuum surrounding the MEG. That would be a serious consequence indeed, but we have seen no proof of it so far.

Besides the argument presented above there is the coil material that is supposed to fully contain the permanent magnet's field and the additional field generated during interaction. A bigger MEG will also need a stronger magnetic field. Just how much can the coil material take before the field starts to break up the material itself? This bigger MEG may need superconducting materials to gain that stronger magnetic field. There will be additional conditions that are imposed by that material. We need to maintain that superconductivity to prevent damage to the material.

However, stronger magnetic fields do pose a health risk. For this reason, most people do not want to live under or very near high voltage power lines. They carry strong electromagnetic fields around them as well. It is however possible to shield magnetic fields.

Shielding

If someone were to switch off the input signal to a large MEG, the field may not die away instantly, which would result in a field spike as it follows suit to the signals. Then EM pulses may arise, which are (very) destructive to all electronic equipment. These EM pulses are so destructive in fact, that some nations have conducted extensive research into their possible application as a weapon.

A Faraday cage would form the "dike around the lake" for the MEG. This is a metal case enclosing the magnetic field plus the MEG completely. With the exception of strong EMP effects it will keep a semi-steady field contained so that no outside negative effects will occur. So in the course of normal operation, the MEG can be shielded quite easily. The worrisome moments occur when switching the MEG on or off. How will the shielding affect the ability of the vector potential field energy to replenish itself as energy leaves the unit?

We Need to Proceed With Caution

Concluding, we can say that the MEG is a means to pour energy from a tremendous reservoir with remarkable little effort. The result is almost limitless energy at practically no cost. The only drawback known in the current state of research is that on a large scale nasty, hard to control side effects may rear their ugly heads. Therefore while the MEG represents a ground breaking and innovative new technology it should not be rushed to market without exhaustive testing.

The Devices of Hans Coler

Hans Coler developed a device which he named the "Stromerzeuger" which consisted of an arrangement of magnets, flat coils and copper plates with a primary circuit powered by a small battery. The output from the secondary circuit was used to light a bank of lamps and it was claimed that the output power was many times the input power and could continue indefinitely.

The apparatus principally consists of two parallel connected spools which being bi-filar wound in a special way, are magnetically linked together. One of these spools is composed of copper sheets (the spool is called the 'plate spool'). The other one is made of a number of thin parallel connected isolated wires (called 'spool winding'), running parallel to the plates, at small intervals. Both spools can be fed by separate batteries (6 Volt, 6.5 Ahr were used). At least two batteries are needed to get the apparatus operating, but subsequently, one battery can be removed.

The spools are arranged in two halves each by the bi-filar windings. The plate spool also contains iron rods with silver wire connections. These rods are magnetised by a special battery through exciter windings. Electrically, the exciter winding is completely isolated from the other windings. Hans said that the production of energy takes place principally in these iron rods and the winding of the spools plays an essential part in the process.

It should be mentioned that the spool circuit is powered up first. Initially, it took a current of 104 mA. The plates and exciter circuits are then switched on simultaneously. When this is done, the current in the spool circuit dropped from 104 mA to about 27 mA.

It is suggested that an electron be not only regarded as a negatively charged particle but also as a South magnetic pole. The basic Stromerzeuger element is that of an open secondary circuit, capacity loaded, inductively coupled to a primary circuit. The novel feature is that the capacities are connected to the secondary core through permanent magnets as shown here:

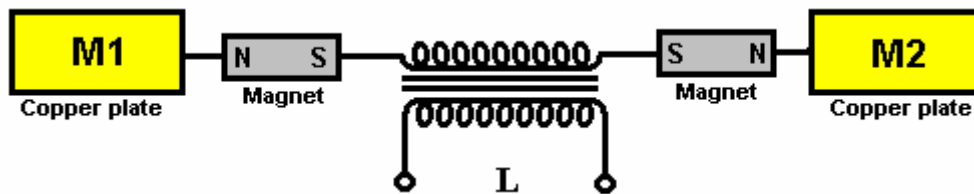

It is claimed that on switching on the primary circuit, "separation of charges" takes place with M1 becoming positively charged and M2 becoming negatively charged and that these charges are "magnetically polarised" when they formed, owing to the presence of the magnets. When the primary circuit is switched off, a "reversing current" flows in the secondary but the magnets "do not exert a polarising effect on this reversal".

Two of the basic elements shown above are placed together making a double stage arrangement with the copper plates close together.

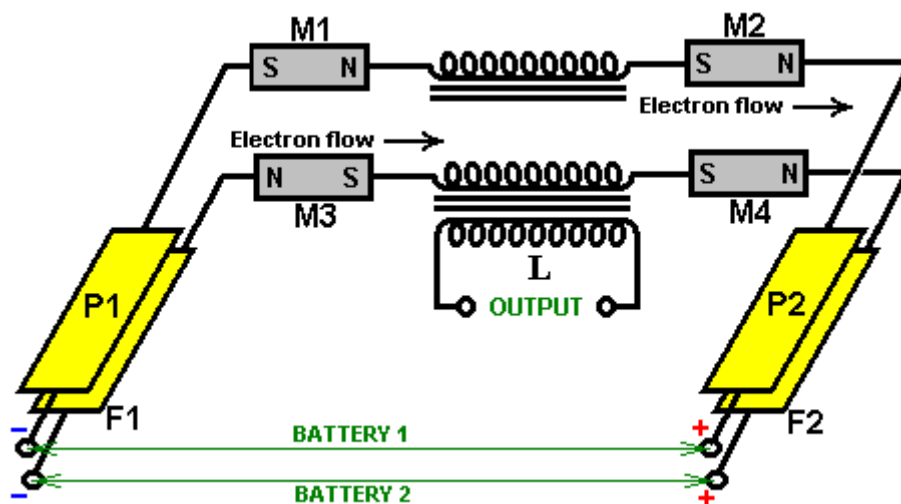

Note that the M1 coil is reversed. The magnets carry current and so it would be reasonable to presume that they are iron magnets rather than ferrite, iron magnets being common sixty years ago, combined with the fact that ferrite magnets do not conduct current and neodymium types were not available in 1925. The secondary windings are both exactly equal and "wound in a direction such that, on switching the primary coil on", the electrons flow from P1 to P2 and from F1 to F2. Again, this is a most peculiar statement as the direction of electron flow is not affected by the direction of winding of the coil, which suggests that the person making the report knew almost nothing about circuitry. It is highly likely therefore, that the brief report which has survived to today, is very vague and lacking in the essential details, the diagrams not indicating the bifilar windings and straight wire lengths mentioned earlier.

One of the very unusual statements made is that the F1/F2 circuit only induces the effect and that the excess power is drawn from the P1/P2 circuit. This is the basic working arrangement. More of these double stages can be added to provide higher outputs, with their outputs connected in parallel for greater current.

The original document, with masterly ambiguity, states that to make this arrangement, two of the original circuits are placed one on top of the other and then promptly draws the arrangement, showing the M1 magnet poles reversed, which of course, contradicts what has just been stated. So, it is not clear if the diagram or the statement is correct, but the likelihood is that the diagram is right.

For there to be any kind of continuous output from a transformer, the input cannot be DC in spite of the fact that dry-cell batteries were used to power the circuits (even though the output could be as high as six kilowatts). Coler stated that his research indicates that permanent magnets actually oscillate at about 180 kHz. If that is correct, then that could account for the magnetic induction produced in the circuit. If that is not what is relied on in this circuit, then the batteries have to be connected and disconnected continuously, and the technology being simple at that time, it seems likely that a relay would have been wired to self-oscillate as in the early electric bells. While that arrangement could have been used just to connect and disconnect the batteries with a relay contact, the relay coil will have generated high-voltage sharp pulses, generating short magnetic pulses of the type which causes an inflow of cold electricity into the circuit from the local ambient background.

Alternatively, although it is not mentioned or suggested, the connection could have been made using a relay which had only one contact, in which case, the back-EMF of the relay coil may have fed high-voltage pulses directly into the circuit. This is, of course, just ill-informed speculation. The arrangement **might** have been:

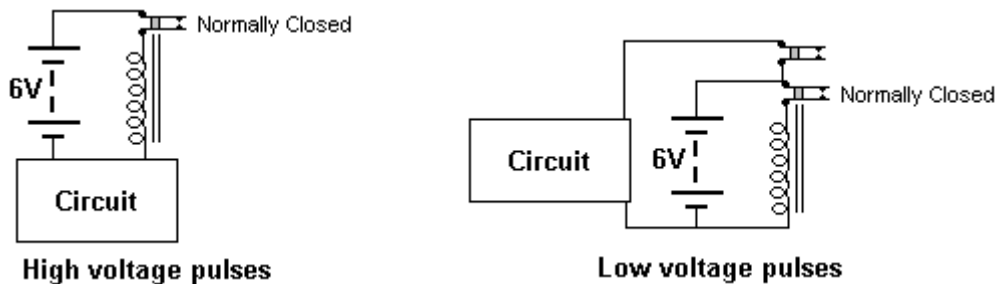

In each case, the battery current flows the normally closed relay contact, powering the relay winding, which opens the switch contact, disconnecting the relay and so closing the switch contact again. This causes rapid pulsing of the battery voltage and the relay coil generates high voltages, typically of some hundreds of volts. If the circuit connection is as shown in the first arrangement, then when the relay switch opens, high back-EMF voltage pulses will be fed to the circuit. On the other hand, if a relay with two separate contacts is used, the second relay switch contact can be used to connect the battery to the circuit and disconnect it again in a very rapid sequence. There is a group of people at <http://tech.groups.yahoo.com/group/testatika/> who are working towards making an operational version of this device. Information on the Coler devices is presented clearly at <http://rimstar.org/sdenergy/coler/index.htm#STROMERZEUGER>.

Patrick Kelly

<http://www.free-energy-info.tuks.nl/>

Chapter 14: Renewable Energy Devices

Heaters.

The devices described here are not “free-energy” devices as such, but in spite of that, it is an area of considerable interest to many people, and the subject is included here because of that.

If you do not live in an urban area, then a solid fuel stove can be an economic solution, especially if the fuel can be collected free from wooded areas. Stove design has advanced considerably and it is now possible to make a simple stove with very high efficiency and very low emissions as shown here:

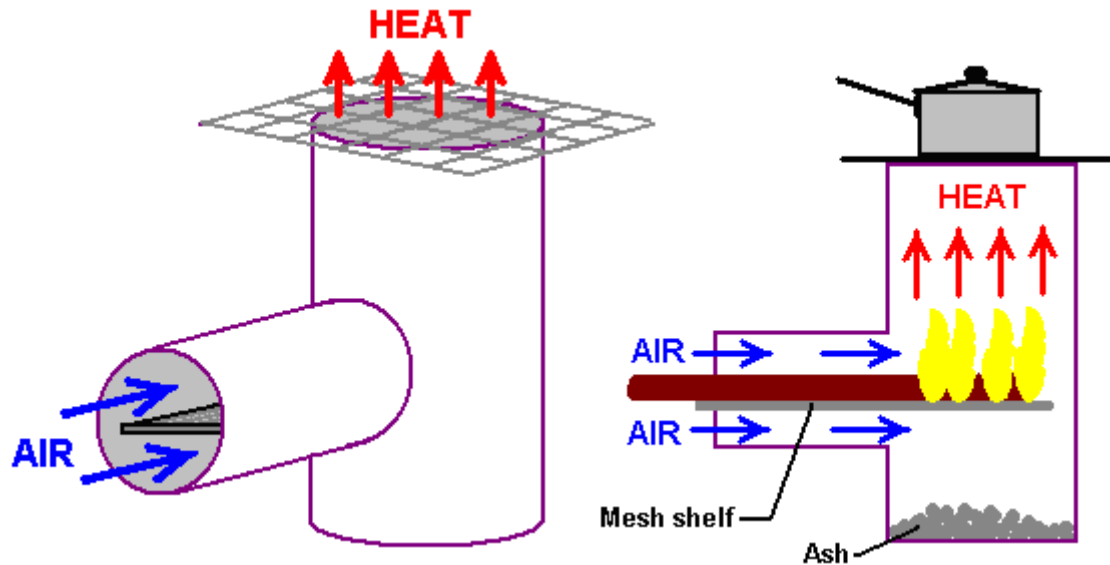

Although this stove is a very simple construction, it's efficiency is very high indeed. The best fuel is made of smaller pieces which rest on a simple shelf. Branches work better than large pieces of wood as the consumption is more complete. As the fuel is consumed, it is pushed further into the stove, which gives the user an appreciation of the rate of consumption. Having the fuel resting on a shelf has the major advantage of allowing air to flow both above it and below it, which gives improved combustion. The operation is said to be so good that there is virtually no residue and no emissions.

Again, if land space is available, a solar oven (or Stirling motor) can be used, either to store energy for later use or generate heat for cooking or home heating, as can hot-water solar panels. However, it is only realistic to consider the application to be during the night in a built-up area with little or no spare space for equipment.

The Wood-Gas Stove.

There is another very effective type of wood-burning stove. There are several commercial versions of this stove on sale, but most of them use an electric fan to get the effect which is produced automatically by this design. This design has been replicated by Alberto Feliciano and found to be very effective in operation. It causes a load of wood which would normally burn up in fifteen minutes to burn for a whole hour, putting out a much greater amount of heat. The design is very straightforward. There is an outer drum which has a solid base, and the opposite end removed entirely as shown here:

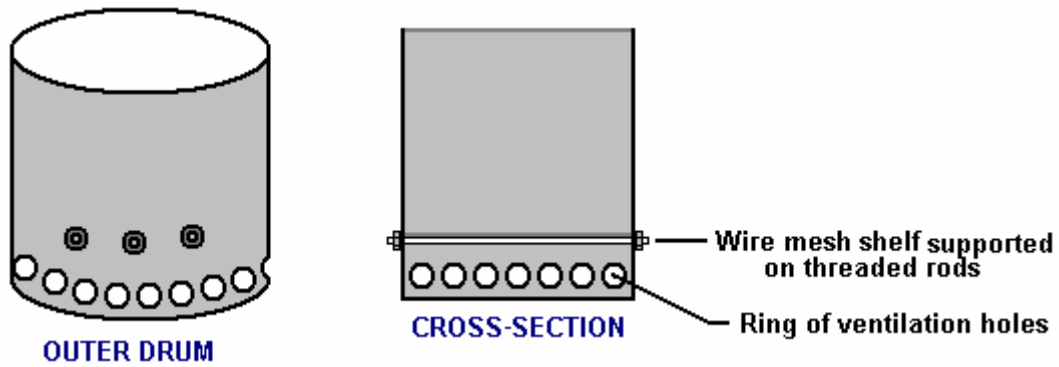

A ring of ventilation holes is drilled around the whole of the bottom edge of the drum and threaded rods are run through the drum. These support a circle of wire mesh which forms a supporting shelf.

A smaller drum then has both ends removed, to form a cylinder. This cylinder is to fit inside the outer drum. It rests on the mesh shelf of the outer drum. This cylinder has a ring of ventilation holes is drilled around the whole of its upper edge as shown here:

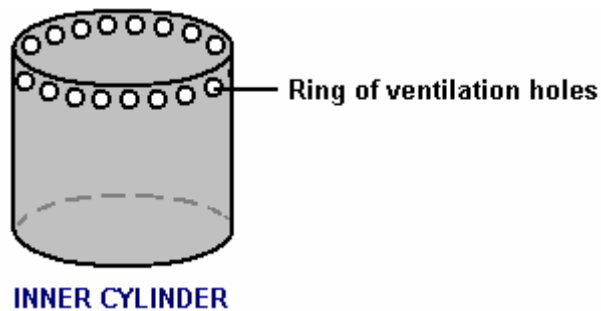

A third drum which is only slightly smaller than the outer drum is cut down to make a cap for the inner cylinder. This cap is not tight-fitting, but it effectively closes off the top of the gap between the sides of inner cylinder and the sides of the outer drum:



This cap has a circular hole cut in it, and this hole is only slightly smaller than the diameter of the inner cylinder. It is supported by the upper lip of the inner drum but the hole is large enough that it does not obstruct the flow of heat up through the top of the inner drum. These three pieces fit together like this:

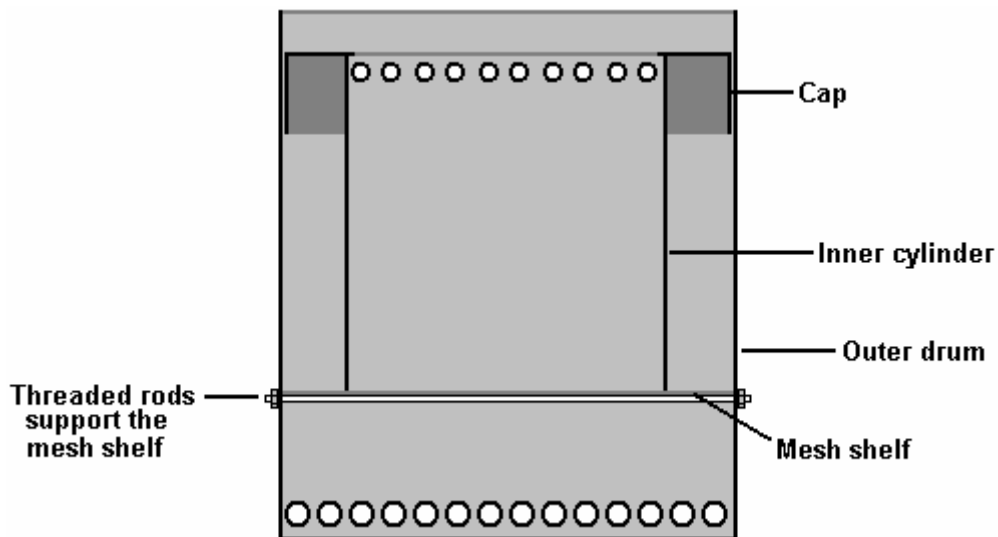

Wood of any type, branches, sticks, firewood, etc. are placed inside the inner cylinder and set alight. Initially, the flames come out of the top of the stove as you would expect, but after a few minutes, the combustion alters completely. The burn now becomes that of wood-gas rather than of the wood itself. The wood is slowly converted to charcoal and the gas released by this process burns with greater heat than the wood would give as well as burning for a much greater length of time. This stove design can be made in any size. Small versions get a burn length of about three times that of the wood burning in the open air, while large versions can reach four times the burn length.

Flames no longer come out of the top of the stove, but instead, they come out of the ring of holes around the base of the outer drum. The process is like this:

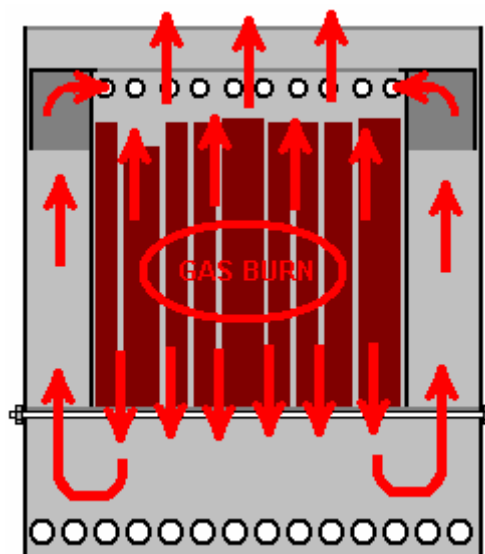

A high-temperature gas burn takes place in the centre of the inner cylinder. This pushes heat out through the top and the bottom of the inner cylinder. The heat flowing out of the top is used for heating or cooking as before. The heat flowing out of the bottom gets diverted around the outside of the inner drum, flows upwards, is caught by the cap and fed back into the inner cylinder through the ring of holes at the top of the inner cylinder. This raises the temperature of the gas burn even further and it augments the heat coming out of the top of the stove. The result is a very hot burn which goes on far longer than would happen if the same wood was burnt on an open fire or in a single open drum. When the wood reaches the end of its burn cycle, it can be replaced by feeding new wood through the hole in the cap which rests on the inner cylinder. The stove will need to be emptied of ash from time to time.

Mr Teslonian's Heating / Fuel-producing / Electricity and Refrigeration System

The Wood-gas stove shown above has been taken several steps further by "Mr Teslonian" as shown in his videos: http://www.youtubekip.com/watch?v=arbXj9R6ZXw&list=PLw28_n7AgcmBtqfnxDV50M-V2JPj3vtFt and http://www.youtubekip.com/watch?v=647R2R_VzG8 where he burns twigs in a home-made wood-gas furnace, heats his house, heats his water, produces engine fuel, runs an electricity generator off the gas and powers a refrigerator. All that, from a few twigs! This is very impressive and he is definitely to be congratulated for his development. His basic wood-gas stove can produce flames up to eight feet (2.5m) tall when operating very effectively on just a few handfuls of short twigs and branches. It looks like this:



This very effective wood burner produces enough heat to heat a house and produce hot water. The wood-gas can also be used to produce both crude oil and fairly well-refined oil which can be used in an engine:

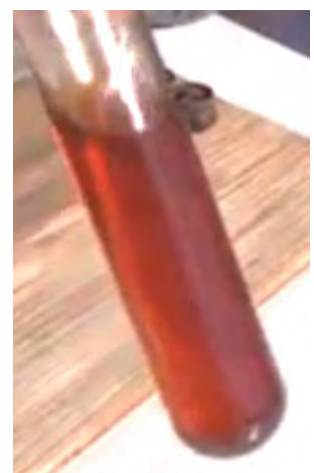

And as you can see from the picture above, the wood-gas can run an electricity generator. There is a world of difference between burning wood like this and a typical camp fire or bonfire.

Wood-gas can also be used to run vehicles (as was done during World War 2). Links to a great deal more information include:

<http://www.woodgas.net/index.html> - an enthusiasts site with basic explanations and many links.

[FEMA emergency gassifer.pdf](#) - construction plans for any full size engine.

[1938 Producer Gas Motor Fuel.pdf](#) - using wood-gas in a vehicle.

[FOA 72.pdf](#) - wood-gas as engine fuel.

[Home made generator\(12v\).pdf](#) - wood-gas generator for charging battery banks.

[World bank tech paper 296.pdf](#) - small scale biomass gasifiers for heat and power

<http://www.free-energy-info.tuks.nl/Oil test.pdf> – the best oils to use with wood-gas engines

Solid Fuel Producing Electricity

We then to think of small-scale solid-fuel burners as providing heat and perhaps a little light as well. The people in Siberia don't think like that and they produce a range of (just) portable solid fuel stoves which provide heating, cooking and 12-volt electricity up to 50 watts. While 50 watts doesn't sound like much, it is a major amount when there isn't any at all available. A small inverter provides mains AC power for smaller appliances:



If it is still there, the video of this is at <http://www.youtube.com/watch?v=2Za98e7-Mxg&feature=related> and the manufacturers (http://www.termofor.ru/eng/products/for_heating/normal_pg/index.html) show a video of this stove design being used in a snow-covered wood at -32 Centigrade temperatures, giving about +35 degrees Centigrade inside the tent. Mind you, weighing in at 54 kilograms which is a whopping 120 pounds or so, this is not a back-packing solution for camping trips. Sales outlets are in Siberia, New York, Australia, Kyrgyzstan, Ukraine, Belarus, Kazakhstan and Latvia at the present time.

The HHO Gas Option.

One significant advantage of this design is that less wood is needed for any give heating or cooking application and there is very little smoke or soot produced which is a distinct advantage for a person using the stove for cooking and standing nearby during the cooking process. This can cause a major medical

improvement as smoke inhalation for women who need to undertake long periods of daily cooking using wood as a fuel, are liable to suffer serious breathing problems as a result.

Electrical heating, while very convenient, is usually expensive, and it often seems that the effectiveness of an electric heater is not directly related to its power consumption. In theory it definitely is, but in practice it just does not seem that way. There are other alternatives.

One of the other documents in this set, shows how to construct a Stanley Meyer style electrolyser which uses ordinary tap water and splits it into burnable fuel using just a low power electrical input:



The difficulty in creating a heating system which uses the gas produced by this unit, is in the very high temperature produced when the gas is burnt. Stan overcame this problem with by designing a special burner which mixes air and burnt gasses in with the gas before it is burnt. That lowers the flame temperature to a level which is suitable for heating and cooking:

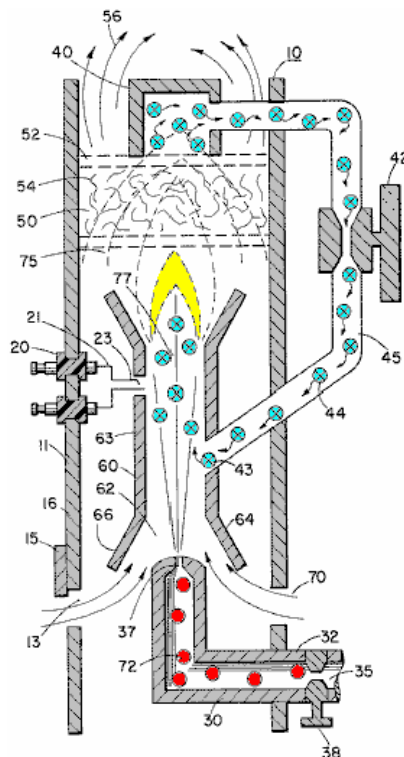

While this looks a bit complicated, it's construction is really quite simple. The combination of the Meyer electrolyser and Meyer burner form a system which has the potential of being operated from a solar panel and battery as shown here:

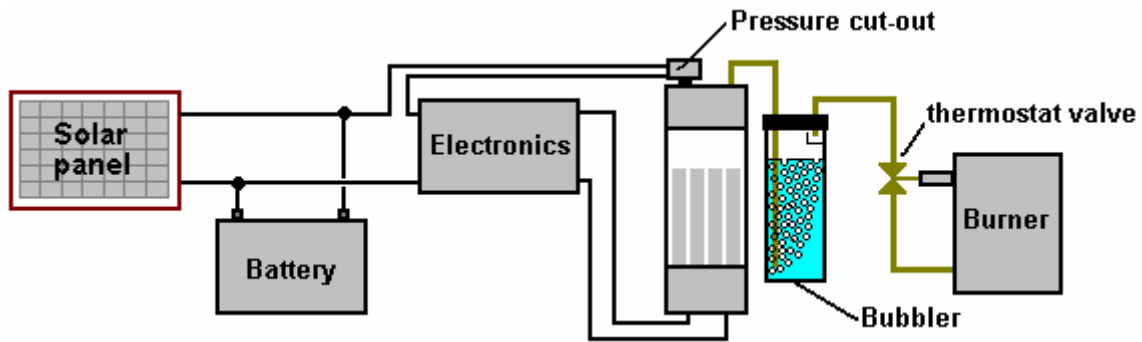

A system like this needs extreme care as the hydrogen / oxygen (“HHO”) gas produced is explosive. So:

1. It is very important that the electrolyser has the ability to provide sufficient gas to keep the flame(s) sustained.
2. The electrolyser must be fitted with a pressure switch, typically operating at 5 pounds per square inch or so. This is included so that should the gas usage drop, then the drive from the electronics is cut off to stop further gas production, and incidentally, stopping the current draw from the battery.
3. It is absolutely essential that there be a flame-operated valve on the gas supply line to the burner, so that should the flame go out for any reason whatsoever, then the gas supply will be cut off. This type of valve is common on town-gas operated fires for use in homes.

Henry Paine’s Patent.

There is an alternative method which it is claimed can convert the explosive HHO gas into a much more docile fuel, more suited to conventional burners and stoves. It must be stressed that this system is over 120 years old and it should not be used until you have carried out careful tests on it. David Quirey has been using this technique successfully for more than twenty years now. The method was patented by **Henry M. Paine** in US Letters Patent No. 308,276 dated 18th November 1884 and it is very simple:

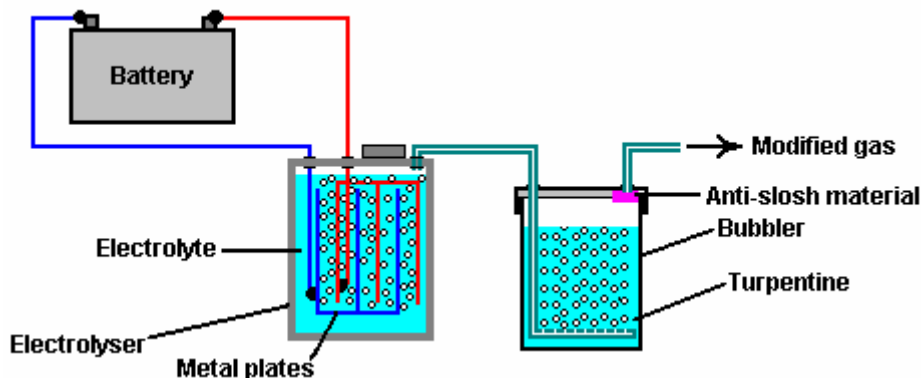

The idea is to bubble the HHO gas produced by electrolysis of water, through a liquid hydrocarbon such as turpentine or acetone. The bubbler should have a large number of small holes in the incoming tube, so that a very large number of small bubbles of HHO gas pass through the hydrocarbon. This brings the majority of the HHO gas into intimate contact with the hydrocarbon and the process is claimed to convert the HHO gas into a new variety of gas which is not explosive, can be stored for later use, and which burns with the same characteristics as coal-gas (“town gas”).

The Heaters of Sang Nam Kim.

Mr Kim of Korea also proposes methods of using hydroxy gas for heating and using Henry Paine's hydrocarbon bubbling method. He has four patents on the subject of heating:

- US 6,397,834 in June 2002 - Heating Furnace
- US 6,443,725 in September 2002 - Energy Generation
- US 6,761,558 in July 2004 - Heating Apparatus

The first of these shows his method of getting both beneficial radiant heat and convection heating from a stone construction like this:

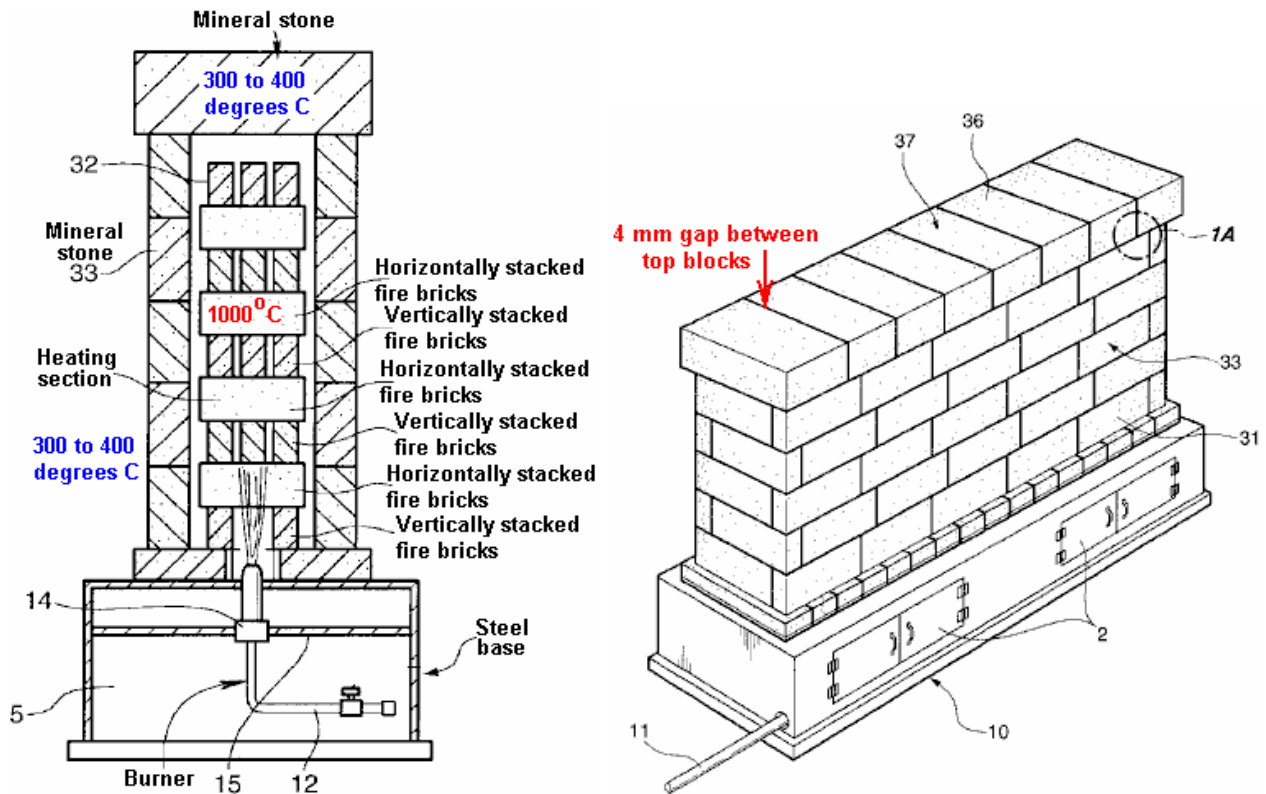

This unit is intended as a seriously powerful heating source for a minimum of one room. Mr Kim quotes a hydroxy gas requirement of 30 litres per minute which is a very considerable amount, and if the gas is produced by electrolysis of water at Faraday efficiency, it would need a current draw of 4.2 kilowatts. There is every indication that Mr Kim's method of electrolysis is low efficiency as his latest patent shows a radiator and fan:

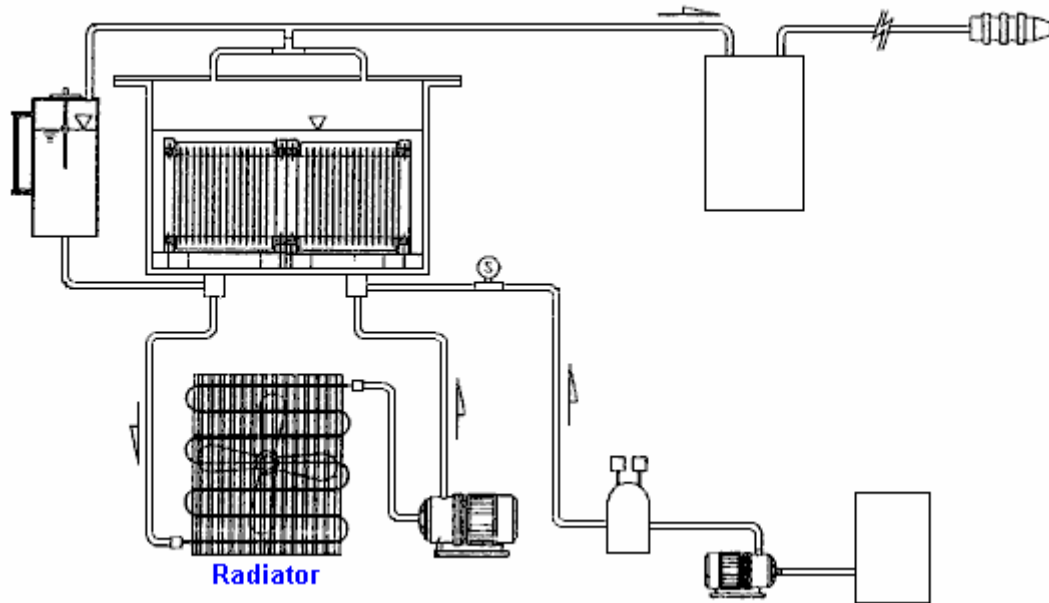

It is virtually certain that there will be a high proportion of hot water vapour mixed in with the gas which is being burnt and that will reduce the explosive nature of the gas to near zero. It also means that the actual volume of hydroxy gas is likely to be well below the 30 lpm quoted by Mr Kim.

Mr Kim also shows a burner intended for use with an existing furnace. He remarks that the outer casing gets to be red hot, running at 1,000°C or more, and so any replication of his design should be treated with care when mounting fixtures are being constructed. In this design, Mr Kim uses the Paine technique and recommends bubbling his hydroxy gas through hexane liquid (C_6H_{14}) where 0.3 litres of hexane per hour gets burnt as well as the hydroxy gas. He rates the hydroxy gas requirement of this burner as being 20 lpm, which at Faraday efficiencies, represents 2.8 kilowatts of electricity, although as mentioned before, it is likely that the actual amount of hydroxy gas in his 20 lpm volume is much lower than he thinks, and so will have a lower electrical requirement when using a more electrically efficient electrolyser. His burner is like this:

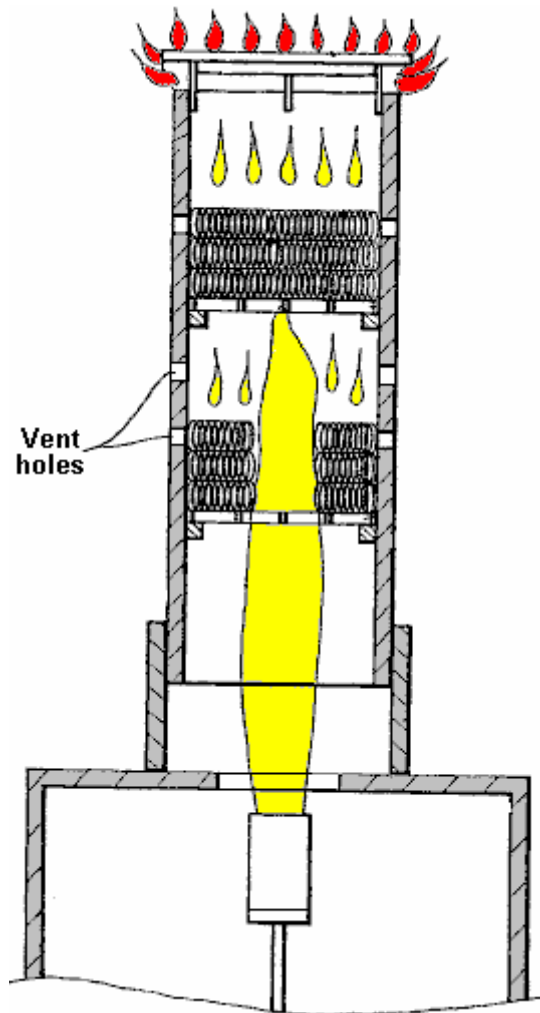

Mr Kim believes that the hexane prevents flashback ignition. He does not appear to specify the heating material inside the burner but it is probably stainless steel wool. He speaks of gas pressures of 1 Kg per sq. cm., which, if my calculations are correct is 14.22 psi. which is not possible for 100% hydroxy gas as it will explode spontaneously at 12 psi. due to its high energy state and electrical charge.

He states that the secondary flames at the top of the unit "burn with a blue flame colour" and that is different to the flame colour lower down. Mr Kim believes that the hydroxy burnt at the bottom of the burner forms water vapour which is then split into hydroxy gas again by the very high temperature and that is the reason for the blue flames at the top. Personally, I don't believe that this will take place and that the effect may have a good deal to do with the hexane liquid being burnt. However, this burner design appears to be a good one for lower grades of hydroxy gas.

If a higher grade of hydroxy gas is being used, please be aware that a hypodermic-size tiny burner orifice will be needed to avoid flashbacks and no commercial flashback arrester will work reliably with good quality hydroxy gas on every occasion and so a bubbler is absolutely essential.

Heating With Electric Power.

Electric power is very popular for heaters. However, with most appliances, it is a very expensive form of heating. There is a technique which is reputed to improve the efficiency and lower the cost of electric heating. This method involves rotating a cylinder inside an outer cylinder and filling part of the narrow space between the cylinders with some variety of light oil.

Eugene Frenette's Patent.

This method has been patented more than once. In 1979, Eugene Frenette was granted patent 4,143,639 where a single motor is used to rotate the drum and power a fan to boost the motion of the hot air:

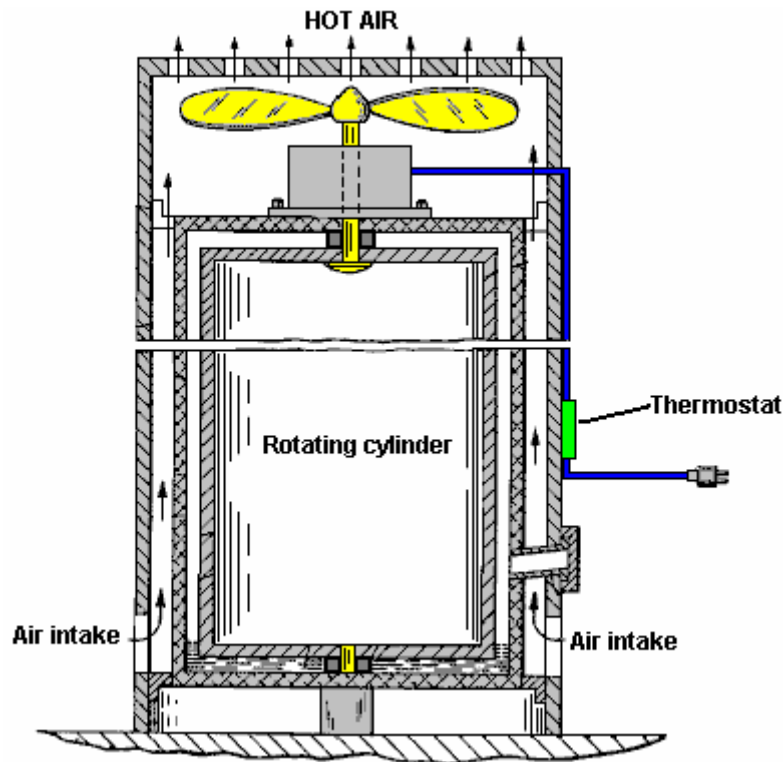

It is not immediately obvious why this arrangement should work well, but it appears that it does. As the inner drum spins around, the oil rises up between the two inner cylinders. It lubricates the bearing under the rotating drum and the rotation causes the oil to heat up. This heats the middle cylinder and air being drawn up around it by the action of the fan blade, is also heated before being pushed out of the top of the heater. After a few minutes, the outer housing becomes so hot that the thermostat attached to it, cuts off the electrical supply.

The heater does not stop heating at this time as air continues to circulate through the heater by ordinary convection. In my opinion, it would be more effective if the fan motor were operated independently and did not cut off when the heater reaches its operating temperature.

Eugene Perkins' Patent.

Very similar systems were patented by Eugene Perkins: January 1984 patent 4,424,797, November 1984 patent 4,483,277, March 1987 patent 4,651,681, October 1988 patent 4,779,575, and in January 1989 patent 4,798,176.

His first patent shows a horizontal drum which is completely immersed in the liquid:

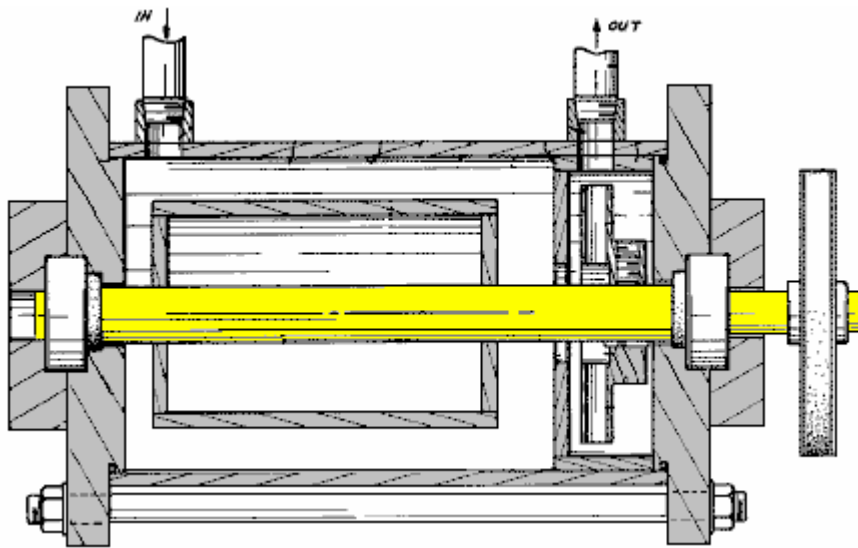

This calls for a much greater accuracy of construction in that the liquid has to be contained even though it has a rotating shaft running through the housing. This device pumps the heated liquid through central-heating piping and radiators.

In his later patent of the same year, he shows a modified version with two drums and an impeller:

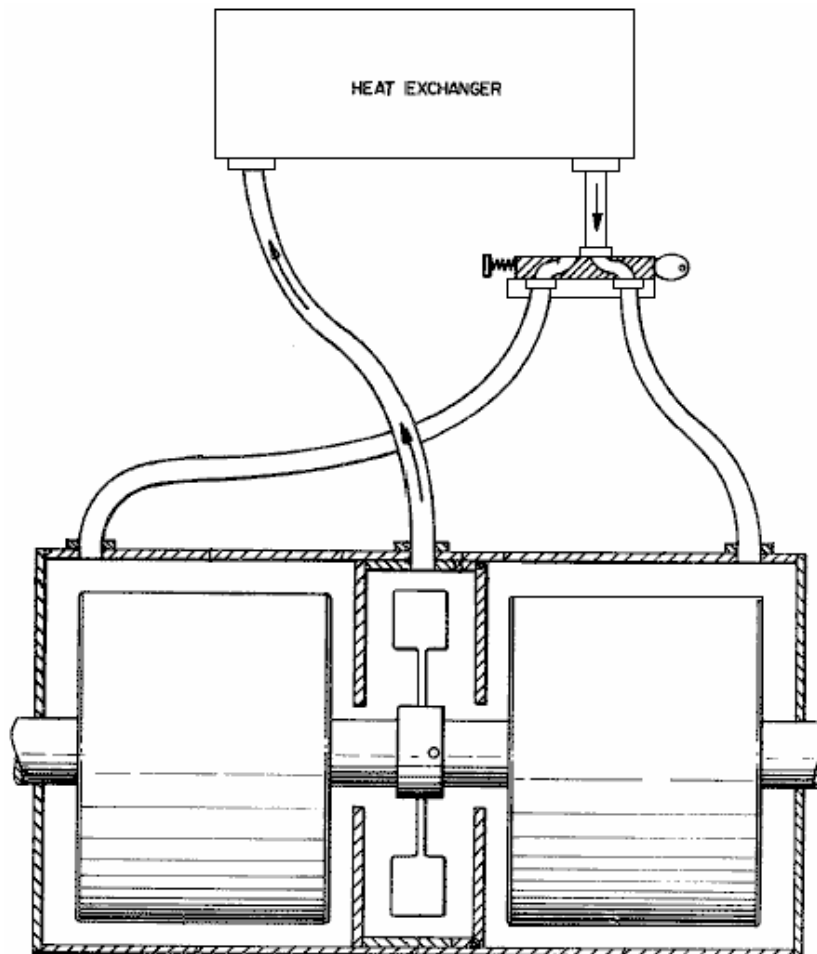

The "heat exchanger" is a radiator or set of radiators.

He then progressed to a system where the shaft rotation forces the liquid to be expelled through the tips of arms radiating out from the centre of the impeller hub:

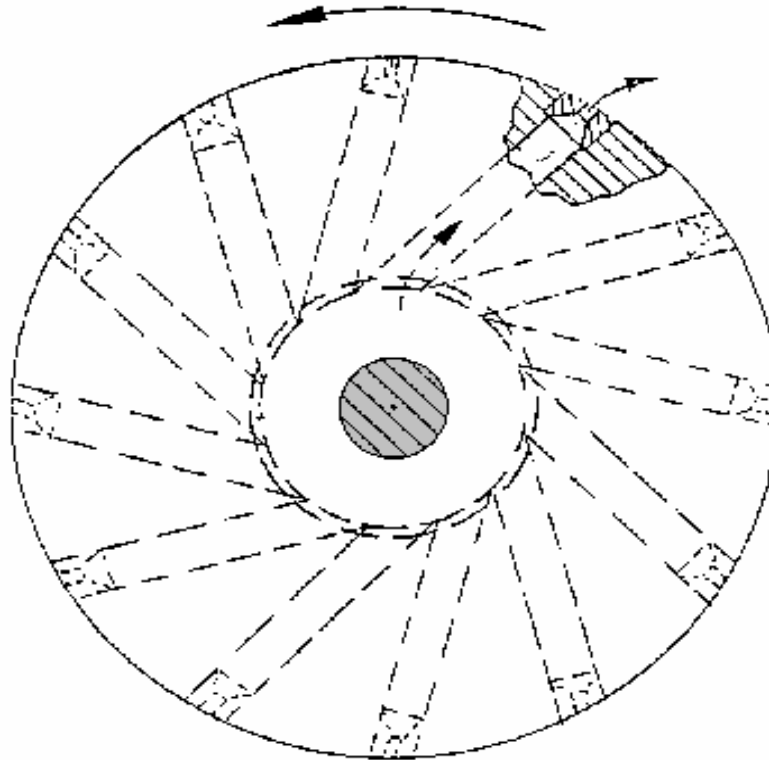

Here, the liquid is forced into a small space between the rotor and its drum housing. This system has been used very successfully for water heating and some measurements indicate that it is at least 100% efficient and some people believe that it is well over the 100% efficiency, though they don't want get drawn into long discussions on methods of measurement. It is sufficient to say here, that this method is very effective indeed.

Frenette Variation: The Frenette heater design shown above with its two vertical cylinders, is not the easiest for the home constructor unless one of the cylinders (presumably the inner one) is constructed from steel sheet, as it is difficult to find two commercially available steel cylinders of just the right relative size to produce the wanted gap between them. A much easier variation replaces the inner cylinder with a stack of circular steel discs. As these can be cut from 20 gauge steel sheet fairly readily by the home constructor, or alternatively, cut by any local metalworking or fabrication company, any available size of outer cylinder can be used and the disc diameter chosen accordingly.

The discs are mounted about 6 mm (1/4") apart on a central steel rod which is rotated in order to drive the discs through the oil contained inside the body of the heater. While this looks like a Tesla Turbine, it is not because the spacing of the discs creates a different effect. The wider disc spacing creates shear as they spin through the surrounding oil, and this shearing creates a high degree of heating. It must be remembered that this is a heater, and the outer canister gets very hot during operation (which is the whole point of the exercise in the first place). For that reason, oil is used as a filling and not water, which boils at a much lower temperature. The larger the diameter of the canister and the greater the number of discs inside it, the greater the heat developed.

To ensure that the discs do not come loose during prolonged operation, a hole can be drilled through them just outside the area covered by the locking/spacing nuts, and a stiff wire run through the holes and the ends either welded to the central rod or pushed through a hole drilled in it and bent over to hold it in place. The heat of the cylinder can be circulated by attaching a simple fan blade to the spinning shaft. This blows air down the hot sides of the canister, moving it towards the floor which is the most effective place for it circulate and heat the entire room.

As the discs spin, the oil is pushed outwards and moves upwards, filling the top of the canister and building up some pressure there. This pressure can be relieved by running an external pipe from the top of the

cylinder back to the bottom, allowing the oil to circulate freely. This has the decided advantage the circulating oil can be passed through a radiator as shown in the following diagram:

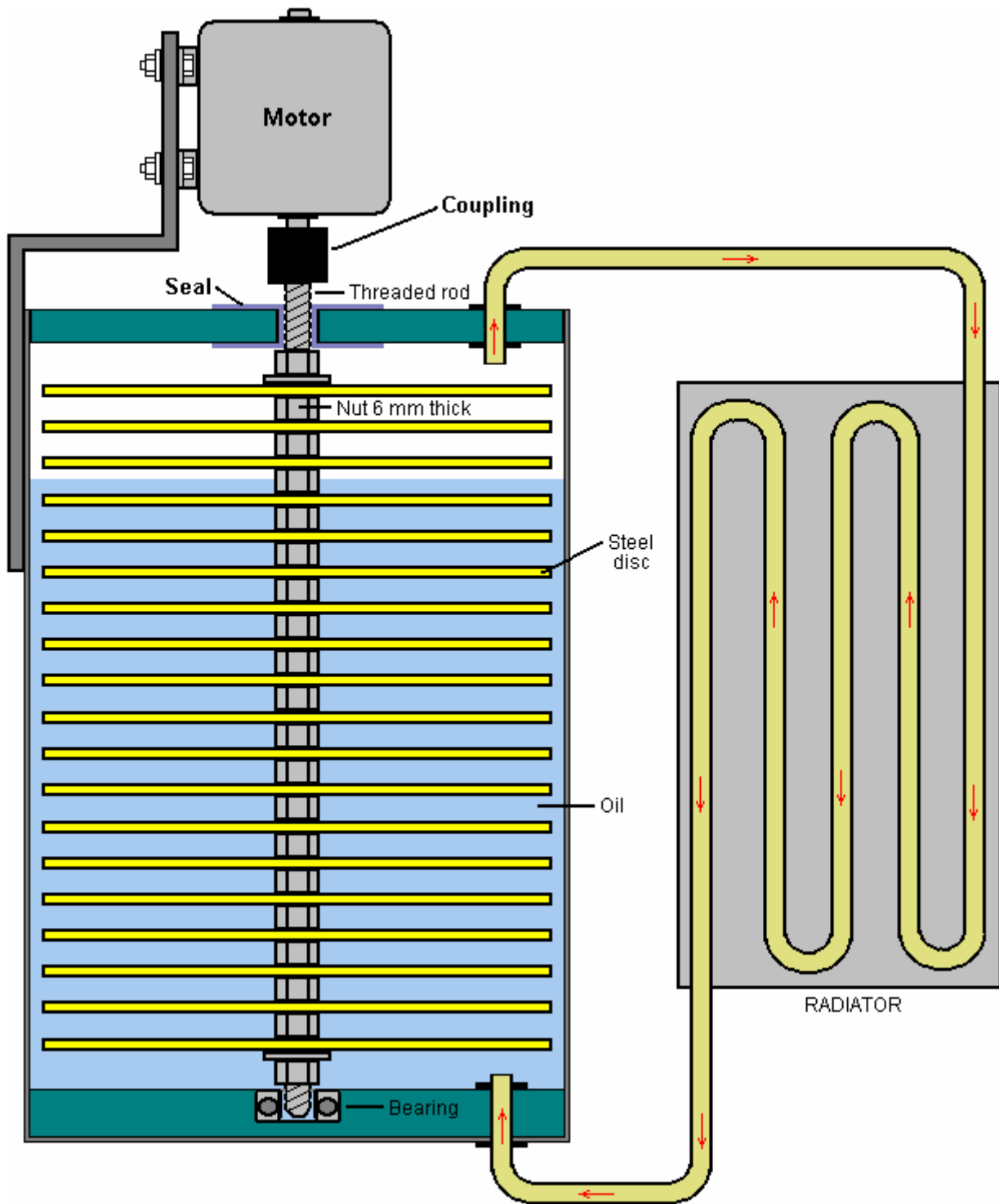

The central rod can be rotated by any convenient motor, conventional, Adams type, pulse-motor, permanent magnet motor, or whatever. An alternative to this style of operation, is to use the rotating motor to spin a ring of permanent magnets positioned close beside a thick aluminium plate. The eddy currents cause very strong heating of the aluminium plate which then can have air blown across it to provide space heating.

Peter Davey's AC Heater.

During World War II, Peter Daysh Davey, of Christchurch, New Zealand, a fighter pilot and musician, designed and built an unusual water heater. This design is not particularly well known and information is fairly thin on the ground although the basic principle and design details are known.



The device is intended to operate on New Zealand's mains supply of 220 volts 50 Hz and a requirement of the apparatus is that it resonates at that 50 Hz frequency. Resonance is a frequent requirement of free-energy systems, and the need for it is often overlooked by people who attempt to replicate free-energy devices. Properly built and tuned, this heater is said to have a COP of 20, which means that twenty times as much heat is produced as would normally be expected from that level of input power. This power gain is caused by additional energy being drawn in from the surrounding environment, and this is very important as a very large percentage of the energy used in cool climates is used for heating, so any reduction would be very welcome.

Peter was granted a New Zealand patent for his heater on 12th December 1944 but he found that opposition from the utility companies was so great that it prevented him from going into commercial production with it and although Peter kept trying for fifty years, he never succeeded.

The device is comprised of a hemispherical resonant cavity, formed by two metallic dome shapes, both of which resonate at 50 Hz. Initially, Peter used two bicycle bells and he found that when submerged in water, the device brought the water to the boil in a very short time indeed. The construction is like this:

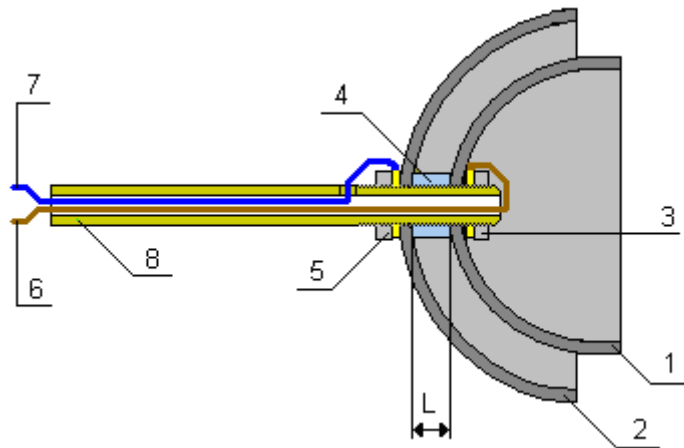

If construction were to use two identical hemispheres, then the cavity between them would be anything but even width throughout, but the resonance would be the same. On the other hand, if you want the resonant cavity between the two hemispheres to be of constant width, then the outer hemisphere needs to be markedly larger than the inner hemisphere. The outside of both hemispheres needs to be insulated unless mounted in such a way that it is not possible to touch the hemispheres as both are attached to the mains.

In the diagram shown above, the mains live wire **6**, is fed through the connecting pipe **8**, and clamped to the inner hemisphere **1**, by nut **3** which screws on to the threaded section of tube **8**. It is important that it is the live wire which is connected to hemisphere **1**. The mains neutral wire **7**, is also fed through the connecting tube **8**, then exits through a small hole and is then clamped on to the outside of the outer hemisphere **2**, by nut **5**, also on the threaded section of tube **8**. The two hemispheres are held apart by a spacing washer **4**, which is made from a high-temperature non-conducting plastic. As the tube **8** connects electrically and mechanically to both mains wires through the two locking nuts **3** and **5**, it is essential that this tube is constructed from an electrically non-conducting material such as plastic. as the tube will be in boiling water

on a regular basis, it is also necessary that the tube material is able to handle temperatures over 100°C and so possible materials include nylon and Teflon.

The washer is a key component of the heater and its thickness is key to the efficiency of the whole device. This thickness **L**, is the tuning control for the cavity. The outer hemisphere is about 8 mm greater in diameter than the diameter of the inner hemisphere. Allowing for the thickness of the metal of the bowl, the resonant cavity will therefore be about 3 mm or one eighth of an inch.

The hemisphere **1** is also tuned to 50 Hz by grinding it carefully until it resonates freely at that frequency. Connecting a loudspeaker in series with a resistor of say, 100K ohms, will give a sound of the exact frequency with which this hemisphere needs to resonate. This tuning needs to be done with the unit fully assembled as the connections to the tube will alter the resonant frequency of the hemisphere. When this is being done, the resonance will be felt rather than heard, so hold the tube lightly so that it can resonate freely. The tuning is done by removing a small amount of metal from the face of hemisphere **1** and then testing for resonance again.

When hemisphere **1** resonates well at the mains frequency, (roughly G two octaves below middle C on a keyboard), the search for high-efficiency heating is carried out by very small adjustments of the gap **L**. The adjustment of the gap **L** is carried out by very careful grinding down of the separating washer **4** and the result is best determined by measuring the length of time needed to boil a known volume of water and the current taken to do that. Repeated tests and recorded results, shows when the best gap has been reached and the highest efficiency achieved. The heater can, of course, be used to heat any liquid, not just water.

This heater is unlike a standard kettle heating element. In the standard method, the water is not a part of the main current-carrying circuit. Instead, the mains power is applied to the heater element and the current flowing through the heater element causes it to heat up, and the heat is then conveyed to the water by conduction. In Davey's heater, on the other hand, the current flow appears to be through the water between the two hemispheres. It seems likely that the actual heating is not produced by current flow at all, but from cavitation of the water caused by the resonating of the cavity between the two hemispheres. This technique is used in small jewellery cleaners where and audio frequency is applied to a cleaning fluid in a small container.

A small amount of electrolysis will take place with the Davey heater as it in effect also forms a single parallel-connected electrolyser. The amounts should be very small as only 1.24 volts out of the 220 volts applied will be used in the electrolysis process.

An early construction of the original heater is shown in the photograph below. The coin shown in the picture is 32 mm (1.25 inch) in diameter. The heater is submerged in water when it is being used, and it brings that water to the boil exceptionally quickly. The unit was tested by New Zealand scientists who were able to vouch for its performance, but who were unable to state exactly how its operation allowed it to output such a high level of heat for such a low level of electrical input. You will notice from the photograph, how carefully the electrical connections and outer bowl are insulated.



The original prototype which Peter made was constructed from the tops of two bicycle bells, only one of which was tuned to 50 Hz. This shows that the device will definitely work if the inner hemisphere is tuned correctly. You can find forum investigation at

<http://www.overunity.com/index.php?topic=4083.msg86151;topicseen> and more recent information at <http://merlib.org/node/5504>.

The Series-connected Heater.

While not a free-energy device, one simple arrangement which I use myself, is an adapted halogen heater. A standard, low-cost halogen heater consists of three separate 400-watt sections with a switching arrangement which allows one, two or three sections to be powered up:

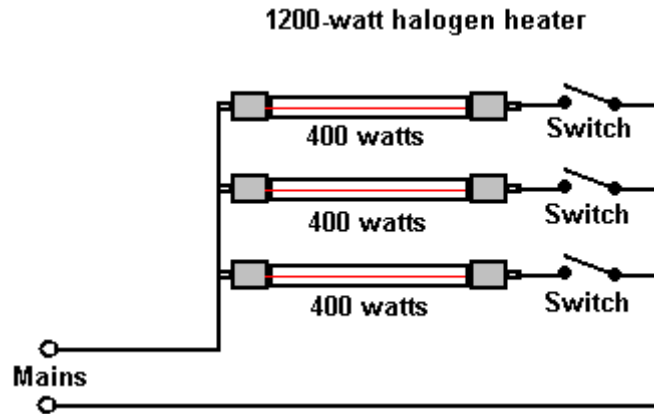

I changed the connections inside my particular heater, so that all three halogen lamps are connected in a chain. This did not involve cutting any wires or making any new connections as the wires connecting to the lamps have push-on 'spade' connectors to allow for both simple manufacturing and easy replacement of a halogen lamp. The new arrangement is like this:

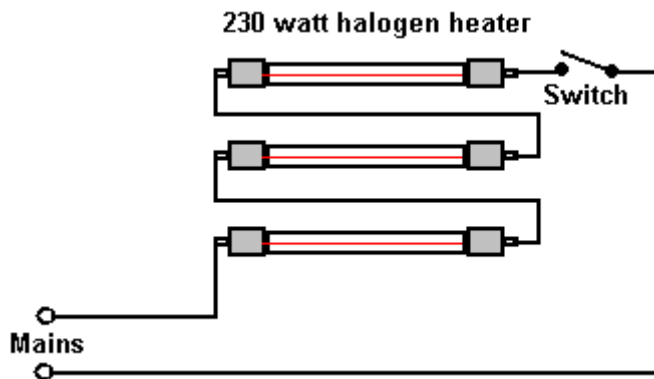

This arrangement 'under-runs' the lamps as each lamp only gets one third of the voltage which it was designed for. This has the effect of increasing the working life of the lamp enormously. You would expect the heat output to be very poor, and perhaps it is. But it gives the impression of being quite effective and with all of the three sections working, it provides a gentle heat and light which seems very effective in keeping a room warm.

The Home Power, Home-Build Wind-Powered Electrical Generator.

Here is an interesting article from the Home Power web site. If you are interested in renewable power, then I strongly recommend that you visit their web site <http://www.homepower.com> and consider subscribing to their magazine as they cover many practical topics using simple wording. Here is an example of the high quality material from Home Power – a 100 watt wind generator built from scratch in just one day:

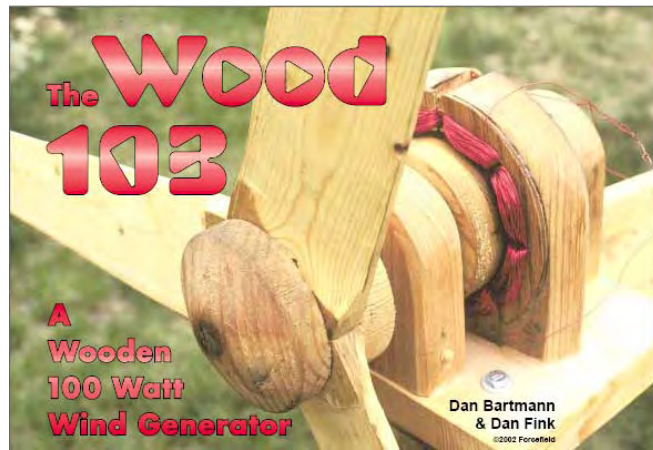

The link for this is: http://homepower.com/article/?file=HP88_pg22_Bartmann.

William McDavid's Wind-Powered Generator.

William McDavid junior remarks that a horizontal axis windmill of that type creates an area of slow-moving air behind the blades and that restricts the flow of air past the blades. A way to overcome that is to project the outgoing air in a direction which does not impede the incoming air. He shows how this can be done in his patent US Patent 6,800,955 of 5th October 2004. In this design, the wind blows into the generator housing and is deflected upwards through the fan blades of a turbine which spins an electrical generator:

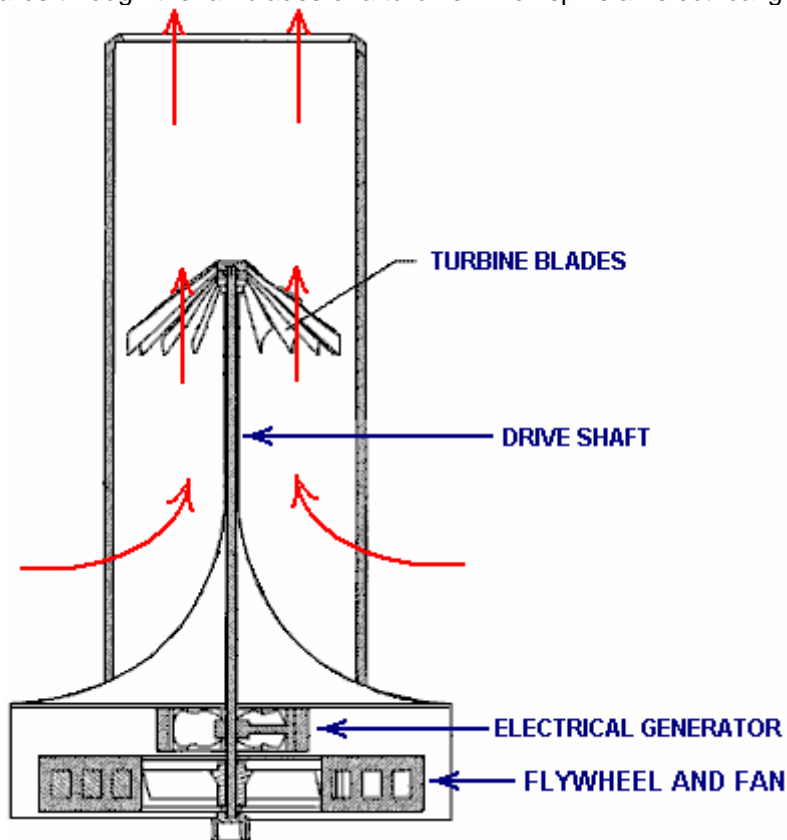

One clever feature common to both of these designs is the use of a stationary circular housing with deflectors which uses the wind flow no matter what the wind direction happens to be at any given moment. Looking down from above, the housing looks like this:

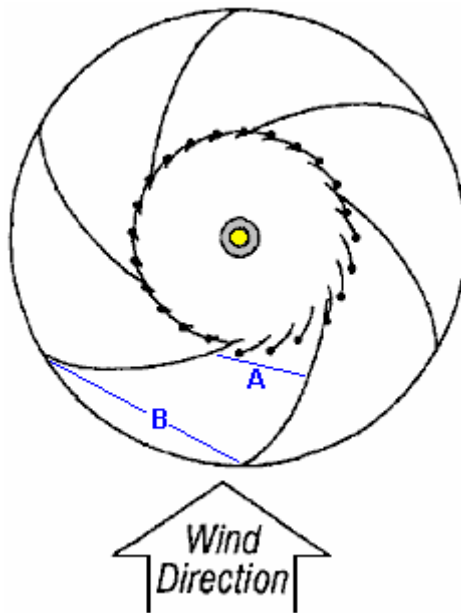

This view shows two important features which enhance the performance of the device. The first is that hinged flaps allow the (horizontal) inflow of air but block the air from flowing straight out of the other side of the central section. This forces the wind to turn and flow upwards, and not only that, but this arrangement causes the air to spin, creating a miniature tornado vortex which amplifies the power of the wind as can be seen from the devastation caused by full-size tornadoes in the environment. As can be seen from the upper diagram, an upward-curving conical piece on the base of the housing assists the airflow to turn upwards as it spins. The spinning air helps to spin the generator blades faster, giving additional power.

A major additional feature is the fact that the dimension "A" is considerably less than the dimension "B" due to the reduced diameter of the housing nearer the centre. This means that the air flowing past the vanes of housing gets squeezed into a smaller space as it flows. This forces the air to speed up, causing the flow inside the central housing to be higher than the wind-speed outside and that boosts the performance of the device. This wind-powered generator looks like a straightforward project for home construction and with the air being deflected vertically, there does not appear to be any reason why several should not be located near each other. William's full patent can be seen in the appendix of this eBook.

Frank Herbert's Wind-Powered Generator.

As has been carefully explained by the above article, if a windmill of the blade variety is mounted low down then it is dangerous, and people on sailing boats have been killed by them. Also, if the blade arrangement is designed to operate well in low wind conditions, then it is not unusual for there to be a problem if the wind rises to gale force or higher, with some generator designs giving up and switching off entirely, even though the available free energy is at its highest level.

This design by Frank Herbert is perfectly capable of being home-built and yet it overcomes these problems as well as being a high-efficiency wind turbine. It has an outside cage which prevents human access to the moving parts inside and the 'cage' is not just for protection but is there to enhance the performance of the device. In passing, windmills can be used to compress air and compressed air cylinders can be used to power vehicles and/or power electrical generators during periods of heavy power requirements. The following information is from Frank Herbert's US Patent 4,142,822 of 1979:

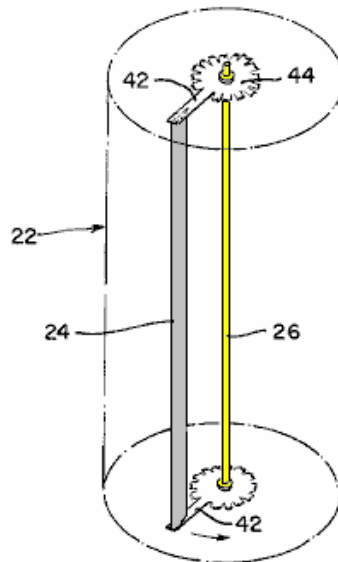

The vertical housing **22** shown dotted here, surrounds the vertical power take-off shaft **26**. The wind is allowed to flow through this housing at any angle, so there is no need for the housing to move. In the diagram above small discs **44** are shown at each end of the vertical shaft. These discs have arms **42** extending outwards to support a series of vertical vanes or pressure surfaces **24**. For clarity, just one vane is shown through there will actually be many of these (rather like the cutting blades on a cylinder lawnmower). In reality, there will be no arms on the discs **42** as it is much easier just to have a full-width solid disc supporting the vanes.

The outer housing has a series of vertical slats which are angled to direct the incoming wind on to the vanes at the best possible angle:

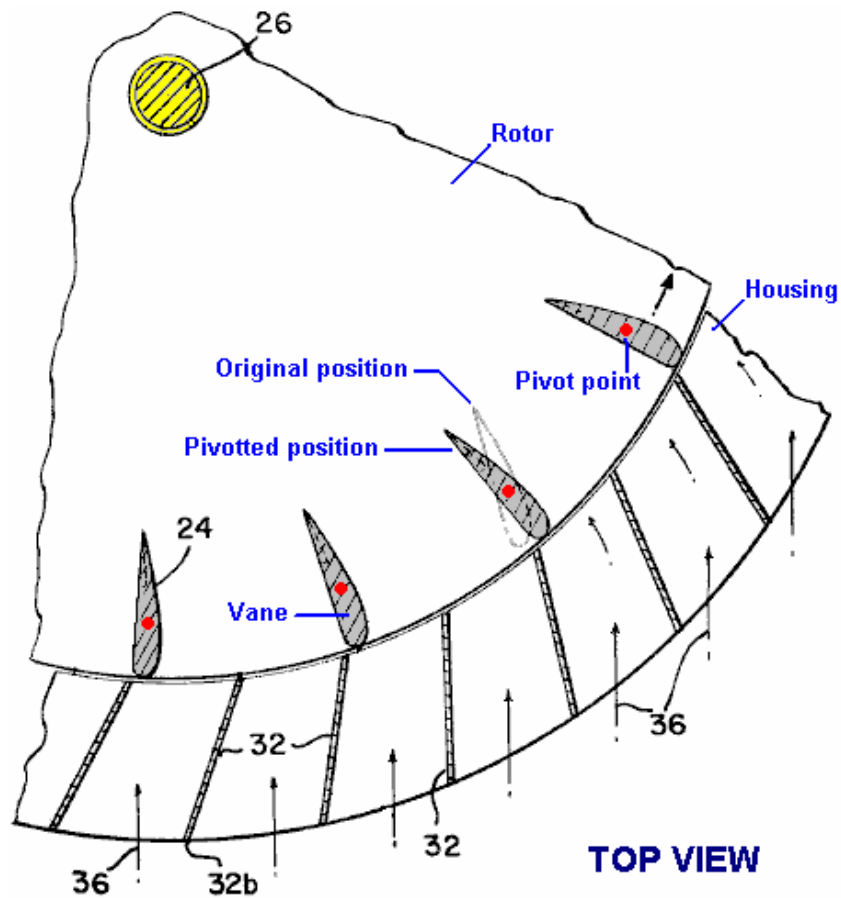

This top view of part of the device, shows the main mounting shaft **26** on which the top and bottom rotor discs are mounted. The red dots show the pivot points where the vanes **24** can turn to take the greatest advantage of the wind pressure. The incoming wind **36**, is deflected by the slats of the housing **32**, to give it

a good angle when flowing through the device as well as keeping humans away from the spinning mechanism. As the vanes and slats are located all the way around shaft **26**, sudden changes in wind direction and/or wind strength have no particular effect on this design as it operates with wind coming from any direction and no physical movement of any part of the device is needed for a change in wind direction.

The vanes can have various different profiles and still work well. The shape shown above is the shape of an aircraft wing, where a force acting towards the curved surface is generated when air flows around the shape. This is not a particularly difficult shape to construct and it is very effective in an airflow (which is why it is used to lift aircraft off the ground). There can be any convenient number of vanes and a device built as shown above should be very effective..

As the overall efficiency is improved if there is no turbulence inside the device, Frank has found a method of minimising this. For this, he uses a mechanism which can alter the shape of the vanes when the windspeed gets high. The higher windspeed whirls the vanes around faster, causing higher 'centrifugal' forces on the vanes which Frank uses as follows. Weight **54** gets pushed across by the spin rate of the rotor.

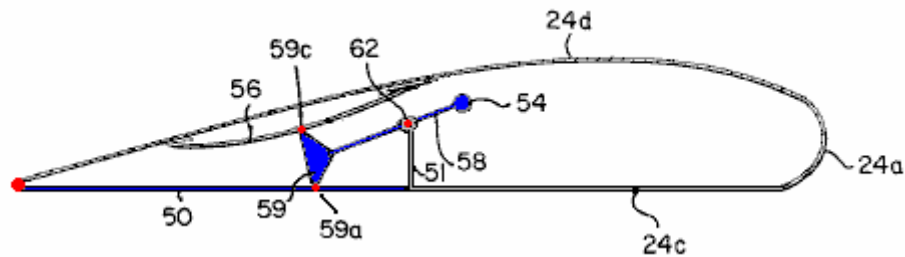

This pushes against the spring **56**, compressing it. The triangle link **59** moves upwards, pivoting at points **59a** and **59c**, and raising section **50** of the vane. This changes the shape of the vane as shown here:

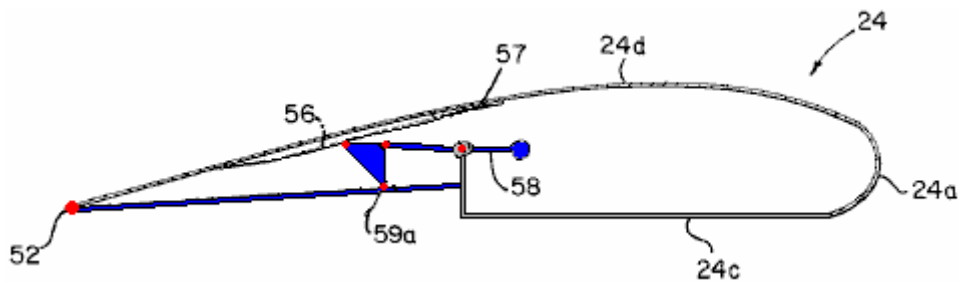

The result of this changed shape is to reduce turbulence inside the device and raise the overall efficiency.

The Mead and Holmes Power System.

The US patent 4,229,661 dated 1980 from Claude Mead and William Holmes is entitled "Power Plant for Camping Trailer" proposes the use of a wind power generator to store compressed air for later use in providing household electrical current, and simultaneously charge batteries which can be used to drive the compressor in periods of very high electrical demand. There is also an option for a rapid system charge if AC mains power becomes available:

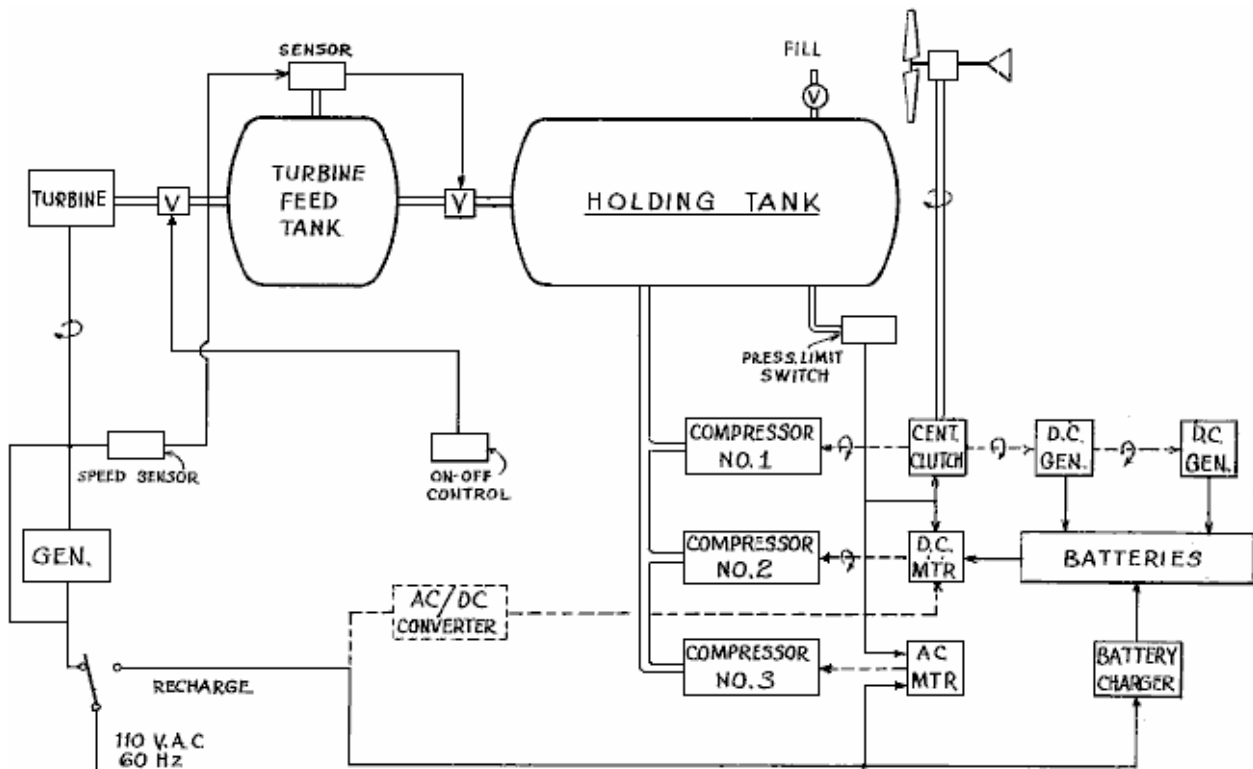

Solar Ovens.

This information comes from <http://solarcooking.org/plans/funnel.htm> and ownership remains with the original authors and the material is reproduced here with their kind permission.

The Solar Funnel Cooker

How to Make and Use The Brigham Young University Solar Cooker/Cooler

by Professor of Physics at Brigham Young University (BYU), with Colter Paulson, Jason Chesley, Jacob Fugal, Derek Hullinger, Jamie Winterton, Jeannette Lawler, and Seth, David, Nathan, and Danelle Jones.



Introduction

A few years ago, I woke up to the fact that half of the people in the world must burn wood or dried dung in order to cook their food. It came as quite a shock to me, especially as I learned of the illnesses caused by breathing smoke day in and day out, and the environmental impacts of deforestation - not to mention the time spent by people (mostly women) gathering sticks and dung to cook their food. And yet, many of these billions of people live near the equator, where sunshine is abundant and free. So.....

As a University Professor of Physics with a background in energy usage, I set out to develop a means of cooking food and sterilising water using the energy freely available from the sun. First, I looked at

existing methods.

The parabolic cooker involves a reflective dish which concentrates sunlight to a point where the food is cooked. This approach is very dangerous since the sun's energy is focused to a point which is very hot, but which cannot be seen. (Brigham Young University students and I built one which will set paper on fire in about 3 seconds!). I learned that an altruistic group had offered reflecting parabolas to the people living at the Altiplano in Bolivia. But more than once these parabolas had been stored next to a shed -- and the passing sun set the sheds on fire! The people did not want these dangerous, expensive devices, even though the Altiplano region has been stripped of fuel wood.

The box cooker: Is basically an insulated box with a glass or plastic lid, often with a reflecting lid to direct sunlight into the box. Light enters through the top glass (or plastic), to slowly heat up the box. The problems with this design are that energy enters only through the top, while heat is escaping through all of the other sides, which have a tendency to draw heat away from the food. When the box is opened to put food in or take it out, some of the heat escapes and is lost. Also, effective box cookers tend to be more complicated to build than the funnel cooker.

While studying this problem, I thought again and again of the great need for a safe, inexpensive yet effective solar cooker. It finally came to me at Christmastime a few years ago, a sort of hybrid between the parabola and the box cooker. It looks like a large, deep funnel, and incorporates what I believe are the best features of both the parabolic cooker and the box cooker.

The first reflector was made at my home out of aluminium foil glued on to cardboard, then this was curved to form a reflective funnel. My children and I figured out a way to make a large cardboard funnel easily. (I'll tell you exactly how to do this later on.)

The Solar Funnel Cooker is safe and low cost, easy to make, yet very effective in capturing the sun's energy for cooking and pasteurising water -> Eureka!

Later, I did extensive tests with students (including reflectivity tests) and found that aluminised Mylar was good too, but relatively expensive and rather hard to come by in large sheets. Besides, cardboard is found throughout the world and is inexpensive, and aluminium foil is also easy to come by. Also, individuals can make their own solar cookers easily, or start a cottage-industry to manufacture them for others.

Prototypes of the Solar Funnel Cooker were tested in Bolivia, and outperformed an expensive solar box cooker and a "Solar Coolkit" while costing much less than either. Brigham Young University submitted a patent application, mainly to insure that no company would prevent wide distribution of the Solar Funnel Cooker. Brigham Young University makes no profit from the invention. (I later learned that a few people had had a similar idea, but with methods differing from those developed and shown here). So now I'm trying to get the word out so that the invention can be used to capture the free energy coming from the sun - for camping and for emergencies, yes, but also for every day cooking where electricity is not available and where even fuel wood is getting scarce.

How it Works

The reflector is shaped like a giant funnel, and lined with aluminium foil. (Easy to follow instructions will be given soon). This funnel is rather like the parabolic cooker, except that the sunlight is concentrated along a line (not a point) at the bottom of the funnel. You can put your hand up the bottom of the funnel and feel the sun's heat, but it will not burn you.

Next, we paint a jar black on the outside, to collect heat, and place this at the bottom of the funnel. Or a black pot with a lid can be used. The black vessel gets hot, quickly, but not quite hot enough to cook with. We need some way to build up the heat without letting the outside air cool it. So, I put a cheap plastic bag around the jar -- and, the solar funnel cooker was born! The plastic bag, available in grocery stores as a "poultry bag", replaces the cumbersome and expensive box and glass lid of solar box ovens. You can use the plastic bags used in American stores to put groceries in, as long as they let a lot of sunlight pass. (Dark- coloured bags will not do).

I recently tested a bag used for fruits and vegetables, nearly transparent and available free at American grocery stores, that works great. This is stamped "HDPE" for high-density polyethylene on the bag (ordinary polyethylene melts too easily). A block of wood is placed under the jar to help hold the heat in. (Any insulator, such as a hot pad or rope or even sticks, will also work).

A friend of mine who is also a Physics Professor did not believe I could actually boil water with the thing. So I showed him that with this new "solar funnel cooker" I was able to boil water in Utah in the middle of winter! I laid the funnel on its side since it was winter and pointed a large funnel towards the sun to the south. I also had to suspend the black cooking vessel -- rather than placing it on a wooden block. This allows the weaker sun rays to strike the entire surface of the vessel.

Of course, the Solar Funnel works much better outside of winter days, that is, when the UV index is 7 or greater. Most other solar cookers will not cook in the winter in northern areas (or south of about 35 degrees, either).

I thought that a pressure cooker would be great. But the prices in stores were way too high for me. Wait, how about a canning jar? These little beauties are designed to relieve pressure through the lid -- a nice pressure cooker. And cooking time is cut in half for each 10°C we raise the temperature (Professor Lee Hansen, private communication). I used one of my wife's wide-mouth canning jars, spray-painted (flat) black on the outside, and it worked great. Food cooks faster when you use a simple canning jar as a pressure cooker. However, you can also put a black pot in the plastic bag instead if you want. But don't use a sealed container with no pressure release like a mayonnaise jar -- it can break as the steam builds up (I've done it)!

How to Build Your Own Solar Funnel Cooker

What You will Need for the Funnel Cooker:

A piece of flat cardboard, about 2 feet wide by 4 feet long. (The length should be just twice the width. The bigger, the better).

Ordinary aluminium foil.

A glue such as white glue (like Elmer's glue), and water to mix with it 50-50. Also, a brush to apply the glue to the cardboard (or a cloth or paper towel will do). Or, some may wish to use a cheap "spray adhesive" available in spray cans. You can also use flour paste.

Three wire brads - or small nuts and bolts, or string to hold the funnel together.

For a cooking vessel, I recommend a canning jar ("Ball" wide-mouth quart jars work fine for me; the rubber ring on the lid is less likely to melt than for other jars I've found. A two-quart canning jar is available and works fine for larger quantities of food, although the cooking is somewhat slower).

The cooking jar (or vessel) should be spray-painted black on the outside. I find that a cheap flat-black spray paint works just fine. Scrape off a vertical stripe so that you have a clear glass "window" to look into the vessel, to check the food or water for boiling.

A block of wood is used as an insulator under the jar. I use a piece of 2" x 4" board which is cut into a square nominally 4" x 4" by about 2" thick. (100 mm square x 50 mm thick). One square piece of wood makes a great insulator.

A plastic bag is used to go around the cooking-jar and block of wood, to provide a green-house effect. Suggestions:

- Reynolds™ Oven Bag, Regular Size works great: transparent and won't melt. (Cost about 25 cents each in U.S. grocery stores.)
- Any nearly-transparent HDPE bag (High-density Polyethylene). Look for "HDPE" stamped on the bag. I've tested HDPE bags which I picked up for free at my grocery store, used for holding vegetables and fruits. These are thin, but very inexpensive. Tested side-by-side with an oven bag in two solar funnels, the HDPE bag worked just as well! **Caution:** we have found that some HDPE bags will melt should they contact the hot cooking vessel. For this reason, we recommend using the oven-safe plastic bag wherever possible.
- An idea attributed to Roger Bernard and applied now to the BYU Funnel Cooker: place a pot (having a blackened bottom and sides) in a glass bowl, and cover with a lid. Try for a tight fit around the bottom to keep hot air trapped inside. The metal pot or bowl should be supported around the rim only, with an air space all around the bottom (where the sunlight strikes it). Put a blackened lid on top of the pot. Then simply place this pot-in-bowl down in the bottom of the funnel - no plastic bag is needed! This clever method also allows the cook to simply remove the lid to check the food and to stir. I like this idea - it makes the solar cooker a lot like cooking over a fire. See Photographs for further details.



Construction Steps

Cut a Half-circle out of the Cardboard



Cut a half circle out of the cardboard, along the bottom as shown below. When the funnel is formed, this becomes a full-circle and should be wide enough to go around your cooking pot. So for a 7" diameter cooking pot, the radius of the half-circle is 7". For a quart canning jar such as I use, I cut a 5" radius half-circle out of the cardboard.

Form the Funnel

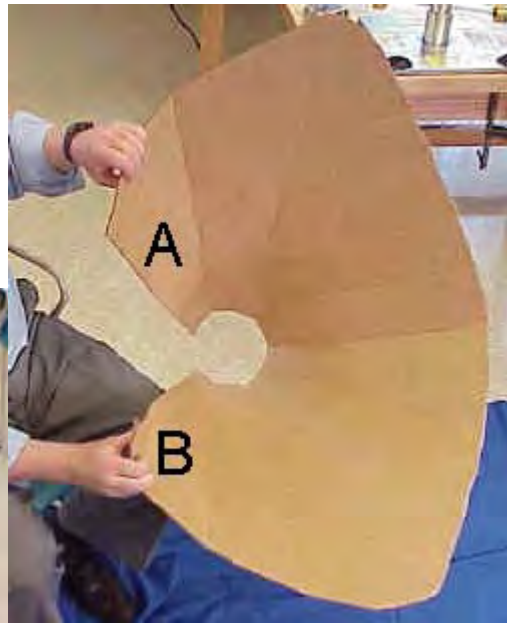
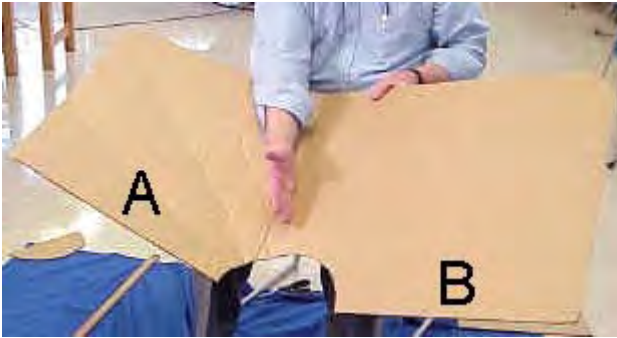

To form the funnel, you will bring side A towards side B, as shown in the figure. The aluminium foil must go on the **INSIDE** of the funnel. Do this slowly, helping the cardboard to the shape of a funnel by using one hand to form creases that radiate out from the half-circle. Work your way around the funnel, bending it in stages to form the funnel shape, until the two sides overlap and the half-circle forms a complete circle. The aluminium foil will go on the **INSIDE** of funnel. Open the funnel and lay it flat, "inside up", in preparation for the next step.

Glue Foil to Cardboard



Apply glue or adhesive to the top (inner) surface of the cardboard, then quickly apply the aluminium foil on top of the glue, to affix the foil to the cardboard. Make sure the shiniest side of the foil is on top, since this becomes your reflective surface in the Funnel. I like to put just enough glue for one width of foil, so that the glue stays moist while the foil is applied. I also overlap strips of foil by about 1" (or 2 cm). Try to smooth out the aluminium foil as much as you reasonably can, but small wrinkles won't make much difference. If cardboard is not available, one can simply dig a funnel-shaped hole in the ground and line it with a reflector, to make a fixed solar cooker for use at mid-day.

Join side A to side B to keep the funnel together.



The easiest way to do this is to punch three holes in the cardboard that line up on side A and side B (see figure). Then put a metal brad through each hole and fasten by pulling apart the metal tines. Or you can use a nut-and-bolt to secure the two sides (A & B) together.

Be creative here with what you have available. For example, by putting two holes about a thumb-width apart, you can put a string, twine, small rope, wire or twist-tie in one hole and out the other, and tie together.

When A and B are connected together, you will have a "funnel with two wings". The wings could be cut off, but these help to gather more sunlight, so I leave them on.

Tape or glue a piece of aluminium foil across the hole at the bottom of the funnel, with shiny side in.



This completes assembly of your solar funnel cooker.

For stability, place the funnel inside a cardboard or other box to provide support. For long-term applications, one may wish to dig a hole in the ground to hold the Funnel against strong winds.

Final Steps

At this stage, you are ready to put food items or water into the cooking vessel or jar, and put the lid on securely. (See instructions on food cooking times, to follow).

Place a wooden block in the **INSIDE** bottom of the cooking bag. I use a piece of 2" x 4" board which is cut into a square nominally 4" x 4" by 2" thick. Then place the cooking vessel containing the food or water on top of the wooden block, inside the bag.

Next, gather the top of the bag in your fingers and **blow air into the bag, to inflate it**. This will form a small "greenhouse" around the cooking vessel, to trap much of the heat inside. Close off the bag with a tight twist tie or wire. Important: the bag should not touch the sides or lid of the cooking vessel. The bag may be called a "convection shield," slowing convection-cooling due to air currents.

Place the entire bag and its contents inside the funnel near the bottom as shown in the Photographs.

Place the Solar Funnel Cooker so that it Faces the Sun

Remember: Sunlight can hurt the eyes: so please wear sunglasses when using a Solar Cooker! The Funnel Cooker is designed so that the hot region is deep down inside the funnel, out of harm's way.



Put the Solar Funnel Cooker in the sun pointing towards the sun, so that it captures as much sunlight as possible. The design of the funnel allows it to collect solar energy for about an hour without needing to be re-positioned. For longer cooking times, readjust the position of the funnel to follow the sun's path.

In the Northern Hemisphere, it helps to put the Solar Funnel Cooker in front of a south-facing wall or window as this reflects additional sunlight into the funnel. A reflective wall is most important in locations farther from the equator and in winter. In the Southern Hemisphere, put the Solar Funnel Cooker in front of a North-facing wall or window to reflect additional sunlight into your cooker.

After Cooking

Remember that the cooking vessel will be very hot: so use cooking pads or gloves when handling it! If you are heating water in a canning jar, you may notice that the water is boiling when the lid is first removed - it gets very hot!

Open the plastic cooking bag by removing the twist-tie. Using gloves or a thick cloth, lift the vessel out of the bag and place it on the ground or table. Carefully open the vessel and check the food, to make sure it has finished cooking. Let the hot food cool before eating.

Helpful Hints

Avoid leaving fingerprints and smudges on the inside surface of the cooker. Keep the inner surface clean and shiny by wiping occasionally with a wet towel. This will keep the Solar Funnel Cooker working at its best.

If your funnel gets out-of-round, it can be put back into a circular shape by attaching a rope or string between opposite sides which need to be brought closer together.

For long-term applications, a hole in the ground will hold the Funnel Cooker securely against winds. Bring the funnel inside or cover it during rain storms.

The lids can be used over and over. We have had some trouble with the rubber on some new canning-jar lids becoming soft and "sticky." "Ball canning lids" do not usually have this problem. Running new lids through very hot water before the first use seems to help. The lids can be used over and over if they are not bent too badly when opened (pry off lid carefully).

The jar can be suspended near the bottom of the funnel using fishing line or string (etc.), instead of placing the jar on a block of wood. A plastic bag is placed around the jar with air puffed inside, as

usual, to trap the heat. The suspension method allows sunlight to strike all surfaces of the jar, all around, so that heats faster and more evenly. This suspension method is crucial for use in winter months.

Adjust the funnel to put as much sunlight onto the cooking jar as possible. Look at the jar to check where the sunlight is hitting, and to be sure the bottom is not in the shadows. For long cooking times (over about an hour), readjust the position of the funnel to follow the sun's path. During winter months, when the sun is low on the horizon (e.g., in North America), it is helpful to lay the funnel on its side, facing the sun.



Tests in Utah

I have personally used the Solar Funnel Cooker to cook lunches over many weeks. My favourite foods to cook are potatoes (cut into logs or slices) and carrot slices. Vegetables cook slowly in their own juices and taste delicious. I also make rice, melted cheese sandwiches, and even bread in the Solar Funnel Cooker. I usually put the food out around 11:30 and let it cook until 12:45 or 1 pm, just to be sure that it has time to cook. I've never had any food burn in this cooker.

I have also cooked food in the mountains, at an altitude of around 8,300 feet. If anything, the food cooked faster there - the sunlight passes through less atmosphere at high altitudes.

I find that people are surprised that the sun alone can actually cook food. And they are further pleasantly surprised at the rich flavours in the foods which cook slowly in the sun. This inexpensive device does it!

Students at Brigham Young University have performed numerous tests on the Solar Funnel Cooker along with other cookers. We have consistently found much faster cooking using the Solar Funnel Cooker. The efficiency/cost ratio is higher than any other solar cooking device we have found to date. Mr. Hullinger also performed studies of transmissivity, reflectivity and absorptivity of alternate materials which could be used in the Solar Funnel Cooker. While there are better materials, such as solar-selective absorbers, our goal has been to keep the cost of the Solar Cooker as low as possible, while maintaining safety as a first priority.

Tests in Bolivia

The BYU Benson Institute organised tests between the Solar Funnel Cooker and the "old-fashioned" solar box oven. The solar box oven cost about \$70 and was made mostly of cardboard. It took nearly two hours just to reach water pasteurisation temperature. The Bolivian report notes that "food gets cold every time the pots are taken from and into the oven." The solar box oven failed even to cook boiled eggs. (More expensive box cookers would hopefully work better.)



An aluminised-mylar Solar Funnel Cooker was also tested in Bolivia, during the Bolivian winter. Water pasteurisation temperature was reached in 50 minutes, boiled eggs cooked in 70 minutes, and rice cooked in 75 minutes. The Bolivian people were pleased by the performance. So were we! (La Paz, Bolivia, August, 1996).

I also donated two dozen solar funnel cookers for people in Guatemala. These were taken there by a group of doctors going there for humanitarian service. The people there also liked the idea of cooking with the sun's free energy. For an aluminised-Mylar Solar Funnel Cooker kit, please contact CRM (licensed manufacturer) at +1 (801) 292-9210.

Water and Milk Pasteurisation

Contaminated drinking water or milk kills thousands of people each day, especially children. The World Health Organisation reports that 80% of illnesses in the world are spread through contaminated water. Studies show that heating water to about 65° - 70° C (150° F) is sufficient to kill coliform bacteria, rotaviruses, enteroviruses and even Giardia. This is called pasteurisation.

Pasteurisation depends on how hot and how long water is heated. But how do you know if the water got hot enough? You could use a thermometer, but this would add to the cost, of course. When steam leaves the canning jar (with lid on tight) and forms "dew" on the inside of the cooking bag, then the water is probably pasteurised to drink. (The goal is to heat to 160° Fahrenheit for at least six minutes.) With a stripe of black paint scraped off the jar, one can look through the bag and into the jar and see when the water is boiling - then it is safe for sure.

Think of all the lives that can be saved simply by pasteurising water using a simple Solar Cooker!

Safety

Safety was my first concern in designing the Solar Funnel Cooker, then came low cost and effectiveness. But any time you have heat you need to take some precautions.

- The cooking vessel (jar) is going to get hot, otherwise the food inside it won't cook. Let the jar cool a bit before opening. Handle only with gloves or tongs.
- Always wear dark glasses to protect from the sun's rays. We naturally squint, but sunglasses are important.
- Keep the plastic bag away from children and away from nose and mouth to avoid any possibility of suffocation.

Cooking with the Solar Funnel Cooker

What do you cook in a crock pot or moderate-temperature oven? The same foods will cook about the same in the Solar Funnel Cooker - without burning. The charts below give approximate summer cooking times.

The solar cooker works best when the UV index is 7 or higher (Sun high overhead, few clouds).

Cooking times are approximate. Increase cooking times for partly-cloudy days, sun not overhead (e.g., wintertime) or for more than about 3 cups of food in the cooking jar.

Stirring is not necessary for most foods. Food generally will not burn in the solar cooker.

Vegetables (Potatoes, carrots, squash, beets, asparagus, etc.)

Preparation: No need to add water if fresh. Cut into slices or "logs" to ensure uniform cooking. Corn will cook fine with or without the cob.

Cooking Time: About 1.5 hours

Cereals and Grains (Rice, wheat, barley, oats, millet, etc.)

Preparation: Mix 2 parts water to every 1 part grain. Amount may vary according to individual taste. Let soak for a few hours for faster cooking. To ensure uniform cooking, shake jar after 50 minutes.

CAUTION: Jar will be hot. Use gloves or cooking pads.

Cooking Time: 1.5-2 hours

Pasta and Dehydrated Soups

Preparation: First heat water to near boiling (50-70 minutes). Then add the pasta or soup mix. Stir or shake, and cook 15 additional minutes.

Cooking Time: 65-85 minutes

Beans

Preparation: Let tough or dry beans soak overnight. Place in cooking jar with water.

Cooking Time: 2-3 hours

Eggs

Preparation: No need to add water. **Note:** If cooked too long, egg whites may darken, but taste remains the same.

Cooking Time: 1-1.5 hours, depending on desired yolk firmness.

Meats (Chicken, beef, and fish)

Preparation: No need to add water. Longer cooking makes the meat more tender.

Cooking Time: Chicken: 1.5 hours cut up or 2.5 hours whole; Beef: 1.5 hours cut up or 2.5-3 hours for larger cuts; Fish: 1-1.5 hours

Baking

Preparation: Times vary based on amount of dough.

Cooking Times: Breads: 1-1.5 hours; Biscuits: 1-1.5 hours; Cookies: 1 hour

Roasted Nuts (Peanuts, almonds, pumpkin seed, etc.)

Preparation: Place in jar. A little vegetable oil may be added if desired.

Cooking Time: About 1.5 hours

MRE's and pre-packaged foods

Preparation: For foods in dark containers, simply place the container in the cooking bag in place of the black cooking jar.

Cooking Times: Cooking time varies with the amount of food and darkness of package.

How to Use the Solar Funnel as a Refrigerator/Cooler

A university student (Jamie Winterton) and I were the first to demonstrate that the Brigham Young University Solar Funnel Cooker can be used - at night - as a refrigerator. Here is how this is done:

The Solar Funnel Cooker is set-up just as you would during sun-light hours, with two exceptions:

1. The funnel is directed at the dark night sky. It should not "see" any buildings or even trees. (The thermal radiation from walls, trees, or even clouds will diminish the cooling effect.)
2. It helps to place 2 (two) bags around the jar instead of just one, with air spaces between the bags and between the inner bag and the jar. HDPE and ordinary polyethylene bags work well, since polyethylene is nearly transparent to infrared radiation, allowing it to escape into the "heat sink" of the dark sky.

During the day, the sun's rays are reflected on to the cooking vessel which becomes hot quickly. At night, heat from the vessel is radiated *outward*, towards empty space, which is very cold indeed (a "heat sink"). As a result, the cooking vessel now becomes a small refrigerator. We routinely achieve cooling of about 20° F (10° C) below ambient air temperature using this remarkably simple scheme.

In September 1999, we placed two funnels out in the evening, with double-bagged jars inside. One jar was on a block of wood and the other was suspended in the funnel using fishing line. The temperature that evening (in Provo, Utah) was 78° F (25.5° C). Using a Radio Shack indoor/outdoor thermometer, a BYU student (Colter Paulson) measured the temperature inside the funnel and outside in the open air. He found that the temperature of the air inside the funnel dropped quickly by about 15° F (8° C), as its heat was radiated upwards in the clear sky. That night, the minimum outdoor air temperature measured was 47.5° F (8.6° C) - but the water in both jars had ICE. I invite others to try this, and please let me know if you get ice at 55 or even 60 degrees outside air temperature (minimum at night). A black PVC container may work even better than a black-painted jar, since PVC is a good infrared radiator - these matters are still being studied.

I would like to see the "Funnel Refrigerator" tried in desert climates, especially where freezing temperatures are rarely reached. It should be possible in this way to cheaply make ice for Hutus in Rwanda and for aborigines in Australia, without using any electricity or other modern "tricks." We are in effect bringing some of the cold of space to a little corner on earth. Please let me know how this works for you.

Conclusion: Why We Need Solar Cookers

The BYU Funnel Cooker/Cooler can:

- Cook food without the need for electricity or wood or petroleum or other fuels.
- Pasteurise water for safe drinking, preventing many diseases.
- Save trees and other resources.
- Avoid air pollution and breathing smoke while cooking.
- Use the sun's free energy. A renewable energy source.
- Cook food with little or no stirring, without burning.
- Kill insects in grains.
- Dehydrate fruits, etc.
- Serve as a refrigerator at night, to cool even freeze water.

(Try that without electricity or fuels!)

The burden for gathering the fuel wood and cooking falls mainly on women and children. Joseph Kiai reports :

From Dadaab, Kenya: "Women who can't afford to buy wood start at 4 am to go collecting and return about noon... They do this twice a week to get fuel for cooking... The rapes are averaging one per week."

From Belize: "Many times the women have to go into the forest dragging their small children when they go to look for wood. It is a special hardship for pregnant and nursing mothers to chop and drag trees back to the village... they are exposed to venomous snakes and clouds of mosquitoes."

And the forests are dwindling in many areas. Edwin Dobbs noted in *Audubon Magazine*, Nov. 1992, "The world can choose sunlight or further deforestation, solar cooking or widespread starvation..."

Americans should be prepared for emergencies, incident to power failures. A Mormon pioneer noted in her journal: "We were now following in their trail travelling up the Platte River. Timber was sometimes very scarce and hard to get. We managed to do our cooking with what little we could gather up..." (Eliza R. Snow) Now there's someone who needed a light-weight Solar Cooker!

Here's another reason to use a solar cooker. Many people in developing countries look to see what's being done in America. I'm told that if Americans are using something, then they will want to try it, too. The more people there are cooking with the sun, the more others will want to join in. A good way to

spread this technology is to encourage small local industries or families to make these simple yet reliable solar cookers for others at low cost. I've used this cooker for three summers and I enjoy it. Cooking and making ice with the funnel cooker/cooler will permit a significant change in lifestyle. If you think about it, this could help a lot of people. The BYU Solar Funnel Cooker uses the glorious sunshine -- and the energy of the sun is a free gift from God for all to use!

Answers to commonly-asked questions

Will the cooker work in winter (in the United States)?

As the sun moves closer to the southern horizon in the winter, the solar cooker is naturally less effective. A good measure of the solar intensity is the "UV index" which is often reported with the weather. When the ultraviolet or UV index is 7 or above – common in summer months – the solar cooker works very well. In Salt Lake City in October, the UV index was reported to be 3.5 on a sunny day. We were able to boil water in the Solar Funnel Cooker during this time, but we had to suspend the black jar in the funnel so that sunlight struck all sides. (We ran a fishing line under the screw-on lid, and looped the fishing line over a rod above the funnel. As usual, a plastic bag was placed around the jar, and this was closed at the top to let the fishing line out for suspending the jar.)

The solar "minimum" for the northern hemisphere occurs on winter solstice, about December 21st each year. The solar "maximum" occurs six months later, June 21st. Solar cooking works best from about 20th March to 1st October in the north. If people try to cook with the sun for the first time outside of this time window, they should not be discouraged. Try again when the sun is more directly overhead. One may also suspend the jar in the funnel, which will make cooking faster any time of the year.

It is interesting to note that most developing countries are located near the equator where the sun is nearly directly overhead all the time. Solar Cookers will then serve year-round, as long as the sun is shining, for these fortunate people. They may be the first to apply fusion energy (of the sun) on a large scale. They may also accomplish this without the expensive infrastructure of electrical power grids that we take for granted in America.

How do you cook bread in a jar?

I have cooked bread by simply putting dough in the bottom of the jar and placing it in the funnel in the usual way. Rising and baking took place inside the jar in about an hour (during summer). One should put vegetable oil inside the jar before cooking to make removal of the bread easier. I would also suggest that using a 2-quart wide-mouth canning jar instead of a 1-quart jar would make baking a loaf of bread easier.

What is the optimum "opening angle" for the funnel cooker?

A graduate student at Brigham Young University did a calculus calculation to assess the best shape or opening angle for the Solar Funnel. Jeannette Lawler assumed that the best operation would occur when the sun's rays bounced no more than once before hitting the cooking jar, while keeping the opening angle as large as possible to admit more sunlight. (Some sunlight is lost each time the light reflects from the shiny surface. If the sunlight misses on the first bounce, it can bounce again and again until being absorbed by the black bottle). She set up an approximate equation for this situation, took the calculus derivative with respect to the opening angle and set the derivative equal to zero. Optimising in this way, she found that the optimum opening angle is about 45 degrees, when the funnel is pointed directly towards the sun.

But we don't want to have to "track the sun" by turning the funnel every few minutes. The sun moves (apparently) 360 degrees in 24 hours, or about 15 degrees per hour. So we finally chose a 60-degree opening angle so that the cooker is effective for about 1.2 hours. This turned out to be long enough to cook most vegetables, breads, boil water, etc. with the Solar Funnel Cooker. We also used a laser pointer to simulate sun rays entering the funnel at different angles, and found that the 60-degree cone was quite effective in concentrating the rays at the bottom of the funnel where the cooking jar sits.

For questions regarding the complete Solar Funnel Cooker kit using aluminised Mylar and a jar for the cooking vessel, please contact CRM at +1 (801) 292-9210.

Tests of the Solar Funnel and Bowl Cookers in 2001

Introduction

With an increase in population and a decrease in available fuels such as wood and coal in developing countries, the need for alternative cooking methods has increased. Solar cookers are an alternative to conventional methods such as wood-fires and coal-fires. They provide usable heat for cooking and pasteurising water, without the harmful side effects such as smoke inhalation that non-renewable sources create. In many countries such as Haiti, Bolivia and Kenya, the need for cheap, effective, and safe cooking methods has increased due to poverty and deforestation. Solar cookers are ideal because they rely on the sun's free energy which is abundant in many of the world's poorest countries. Though there are good designs, more testing and improvement is desirable.

There are three areas of comparison that were focused on during the course of the study. The first area of comparison is in the reflective material used. The original material is a mirror-finished aluminium Mylar. Due to the mirror finish, the reflection light is very bright and can be difficult to work over when cooking. An alternative material is a matt-finish Mylar. This material diffuses the sunlight and is not as harsh on the eyes as is the mirrored finish.

The second area of concentration is on the method of containing the air that surrounds the cooker so that the cooker is kept from being cooled by convection currents. A common method is to use a clear plastic oven-safe bag around the cooking vessel. However, this method is rather tedious and awkward to use, and such bags are rarely available in developing countries. Another technique is to use a disk or window made out of a clear plastic or glass. This makes the cooker easier to use.



The third main area of focus is in the cooking containers used. The present cooking vessel for the Solar Funnel Cooker is a black-painted canning jar. This method is also tedious and awkward. The canning jars can be hard to clean, and they can break. Design changes are tested that would allow people to use their own cookware. This too would make the cooker more convenient to use.

The fourth area of testing pitted the wooden block support which we have been using for years against a rabbit-wire support. A rabbit-wire cylinder holds the cooking vessel up off the bottom of the cooker, and allows sunlight to strike essentially all surfaces of the cooking vessel, including the bottom.

The effectiveness of these methods is tested and compared both qualitatively and quantitatively. In addition to acquiring temperature-rise versus time data, we also cooked numerous meals in the solar cookers so as to get hands-on experience with cooking. Several students participated in these cooking tests.

Cooker Designs:

Several solar cooker designs were used during these tests. The Solar Funnel Cooker was the main cooker tested. A Solar Cookit and a bowl-shaped variation of the Solar Funnel Cooker were also tested. Most experiments were comparative tests between the various designs, and the cooker set-up was varied from test to test. The basic design of the Solar Funnel Cooker is a funnel-shaped aluminium Mylar collector. A highly reflective material is necessary to collect and concentrate the sun's rays. The funnel walls are at a 60 degree angle (with respect to the horizontal) since this collects sunlight for a two hour time period without requiring re-orientation to follow the sun. Due to the way the Mylar sheets are cut and folded, a pair of wings

on opposite ends of the funnel is formed. The wings increase the collector size and create an elliptical shape at top. At the tips of the wings, the cooker stands about 20 inches high and has a diameter of about 28 inches. At the top, along the minor axis of the elliptical funnel, the cooker stands about 15 inches high, and has a diameter of about 20 inches. Since the Aluminium Mylar does not support itself well, a nine inch diameter by five inch high bucket is used to support the funnel.



The cooking container primarily tested is a glass canning jar that has been painted flat black. The black paint allows the jar to absorb the sun's rays. The canning jar works well due to the added pressure-cooker effect caused by the rubber ring on the inside of the lid. A black-enamel pot and a black-painted stainless steel canister were also used. We found immediately that raising the vessel off the bottom of the cooker using a rabbit-wire stand provided more rapid and even heating than the wooden block used previously. Placing the jar or pot on a wire stand allows as much reflected light onto the cooking vessel as possible. This allows even the bottom of the cooking container to absorb thermal energy that is reflected off the lower portion of the funnel.

Two methods of closing the cookers off from convection currents were used. It is important to keep the air that surrounds the container from circulating, thus keeping the cooking container from being cooled by convection currents or breezes. This first method used was to enclose the cooking vessel and wire stand in a clear plastic bag, such as a heat resistant Reynolds Oven Bag. It is important to make sure that the bag is not touching the cooking vessel, so once the vessel is placed into the clear bag, air is blown into the bag and the bag is tied off. This is the most common method used for solar panel cookers, such as the Solar CookKit, because of the bags' ability to withstand the temperatures attained in these types of cookers. But these bags tear rather easily and they are not readily available in developing countries and must be imported.

The second method of closing off the cooking vessel from convection currents, designed by Dr. Jones, is to place a clear plastic disk down into the funnel above the cooking vessel. The funnel used in the test was a conventional-shaped funnel that was constructed out of thin sheet metal and aluminium-foil lined for better reflectivity. The diameter of this funnel is about 30 inches at the top, and it stands about 16 inches high. The walls also form about a 60 degree angle with respect to the horizontal. This funnel was designed to hold a larger cooking container such as a pot. The diameter of the plastic disk is large enough that the disk does not touch the top of the container. For the experiments that tested this method, a one-sixteenth inch (1.6 mm) thick Lexan disk was used.

Data Collection

To collect the temperatures as a function of time, a Texas Instruments Calculator Based Laboratory (CBL) was used. This portable interface is capable of recording real-time data from multiple channels. The data were downloaded into a graphing calculator, where they can be analysed and graphed immediately. From the calculator, the data can be transferred to a computer spreadsheet such as Microsoft Excel for further analysis. Due to the nature of these experiments and the low cost to purchase the CBL, this is an ideal data collector to use. A graphing calculator was used to program the CBL and to tell it what data to collect, how many points to collect, and the time period between data points collected. Since the CBL does not have any internal programs for data collection, a program must be written into the graphing calculator. There are

ready-made programs that can be uploaded into the calculator, or a custom program can be made to fit the needs of the test. The program that the CBL used allowed multiple thermocouples to collect data simultaneously. To ensure that the thermocouples were calibrated against each other, both were run on the same constant temperature sample in very close proximity. Both temperature probes agreed to within 0.21°C of each other. For these experiments, this temperature difference was considered to be acceptable.

Procedure

Each experiment was conducted on the campus of Brigham Young University during mid-day, usually between 11:00 am and 2:00 pm to ensure that the sun was close to being directly over-head. This allowed as much sun light as possible to enter the solar collector. Each experiment included several steps, as listed below.

Before each experiment was set up, the volume of the water and the mass of the container were measured and recorded. The heat capacity of the water and the container were also found. The area of the cooker perpendicular to the sun's rays was also measured. To collect temperature data using thermocouple probes, small holes were drilled into the top of the canning jar and stainless steel canister lids. The jar and canister were both painted ultra-flat black to absorb as much of the sun's energy as possible.

On the morning of each test, the designated volume of water was measured out and poured into the cooking vessel. This volume ranged from 0.6 litre for one-quart jars, to 1.2 liters for half-gallon canning jars. For simultaneous testing, the same amount of water was poured into each container. The temperature probes were wired through the holes in the lids of the containers and secured about 13 mm into the water. For comparative tests, the probes were placed the same depth into the water to ensure that the probes did not read different measurements due to depth-related temperature differences within the containers. To enable later analysis; the time, ambient temperature, and solar irradiance were also noted and recorded. These numbers gave a reference point for each test. Each cooker that was to be tested was then completely set up. The temperature probes were secured through the lids, and the jar was placed into the clear oven bag – supported by a wire cage. Each bag was inflated so that no part of the bag touched the sides or top of the cooking container. The cord from the thermocouple to the CBL was passed through the top of the bag, and the bag was tied off with a twist-tie.

The test began once both cookers were completely ready and the CBL had been programmed. Care was taken to block the sun from radiating directly onto the cookers until both were ready to begin. This ensured that the water in both cookers started at very nearly the same temperature. Most tests were set up to collect one data point every four to five minutes, for up to two hours. This allowed the cooker temperatures to reach maxima and then remain at a nearly constant temperature. Once a test was complete, the cooker was disassembled and the data downloaded into the graphing calculator. Though the graphing calculator does allow analysis, a spread sheet such as Microsoft Excel is easier to use. Thus, the data from each test were downloaded from the calculator into Microsoft Excel. The elapsed time (in seconds) and the corresponding temperatures were listed next to each other. A graph of temperature versus time was made, with the Time being the horizontal axis for each test. For comparative tests, the Temperature versus Time data for both cookers was plotted on the same graph. As a reference, a trend-line was fitted to the linear portion of the graph, along with the linear regression and the coefficient of correlation (R^2). It is important to have a coefficient of correlation close to one, as this is how close the linear regression fits the data. In a separate column, the temperatures were again listed, however only from 30°C to 70°C . The change in temperature for every ten or twelve minutes was found and logged next to the temperature column. The power output (in Watts) of each cooker could then be calculated.

To calculate the power output of the cookers for each specific test, the mass of the water and of the container were both measured. Though the thermal energy content of the container was relatively small compared to that of water (due to the large heat capacity of water), it was important to add it into the calculation. Also, since several different containers were compared, the energy content of the container was important. The power is found by:

$$Q_{(out)} = Q_{(water)} + Q_{(container)}$$

$$Q_{(out)} = (m_w c_w + m_c c_c) \Delta T$$

$$Power_{(out)} = \frac{Q_{(out)}}{\Delta t}$$

The power is found in Watts. A power output for each change in temperature for the time interval is calculated and logged next to the T column. Since there are uncertainties in all of the measurements, it is important to include the error in each power output. To do this, the error in the water's and container's measurements is taken into consideration. The error is found by:

$$\pm \Delta P = \sqrt{\left(\frac{\partial P}{\partial m_w} \Delta m_w\right)^2 + \left(\frac{\partial P}{\partial m_c} \Delta m_c\right)^2 + \left(\frac{\partial P}{\partial t} \Delta t\right)_w^2 + \left(\frac{\partial P}{\partial t} \Delta t\right)_c^2 + 2\left(\frac{\partial P}{\partial T} \Delta T\right)_w^2 + 2\left(\frac{\partial P}{\partial T} \Delta T\right)_c^2}$$

Where $\pm dP$ is the total error in the calculated error, dm_w and dm_c are the error in the mass of the water and container respectively, ΔT_p is the error in the temperature difference, and Δt is the error in the time interval.

This simplifies to:

$$\pm \Delta P = \sqrt{\left[\left(\frac{c_w \Delta T}{t} \Delta m_w\right)^2 + \left(\frac{c_c \Delta T}{t} \Delta m_c\right)^2 + \left(\frac{m_w c_w \Delta T}{t^2} \Delta t\right)^2 + \left(\frac{m_c c_c \Delta T}{t^2} \Delta t\right)^2 + 2\left(\frac{m_w c_w}{t} \Delta T_p\right)^2 + 2\left(\frac{m_c c_c}{t} \Delta T_p\right)^2}\right]}$$

The error was found only for the average change in temperature, rather than for each individual temperature measurement. Since the power output is dependant on the amount of energy coming in from the sun, the cooker efficiency is a good factor to calculate. To find the efficiency, the total amount of local solar radiation must be known. This should be given in watts per square metre, so that the input wattage can be found. To find the power coming in, the area of the cooker perpendicular to the sun's rays was multiplied by the solar radiation to give the amount of power that was being collected by the cooker. Since the Solar Funnel is able to be kept on track with the sun, and since the tests were done during mid-day, it was not necessary to calculate any angles. The efficiency is simply the power output divided by the power input. The solar radiation for each test was supplied by the Department of Physics and Astronomy weather station at Brigham Young University in Provo, UT, where the tests took place.

Results:

Matt vs. Mirror: Several tests were conducted on the matt versus mirror finishes. In each test, the matt finish outperformed the mirror finish. On 27 July, 2001, a matt funnel and a mirror funnel were simultaneously tested with 650 cc of water. The average power output for the mirror finish was 46.4 W \pm 1.7 W, while the matt funnel put out an average of 59.4 W \pm 2.1 W. The efficiency of the mirror funnel was 15.8%, while the matt was 20.2% efficient.

The following graph shows the temperatures reached by the matt and mirror funnels.

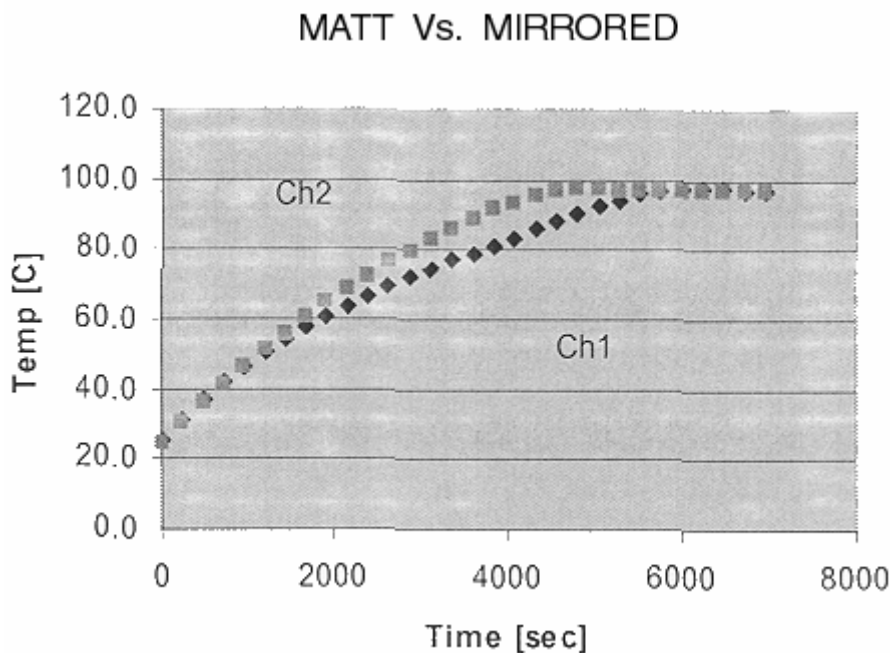

Channel 1 (Ch1) was the mirror finish, and channel 2 (Ch2) was the matt finish. This shows that both funnels peaked at about the same temperature: 97°C (207°F). The matt funnel peaked in about 76 minutes, whereas the mirror funnel peaked in 96 minutes, twenty minutes later. Though this perhaps a tolerable time difference for actual cooking, it is substantial. Every matt vs. mirror test performed in a similar way. These results are due to the way the matt funnel reflects the sun's rays. The mirror finish seems to focus a strip of light onto the cooking vessel more than the matt finish does. As a result, the matt finish diffuses the light more and the cooker is heated more uniformly. This is good, since the matt finish is easier to work with, delivering much less glare to the eyes.

The following graph shows the temperature rise with time for a Solar Cookit:

Solar Cookit 1 (7/16/01)

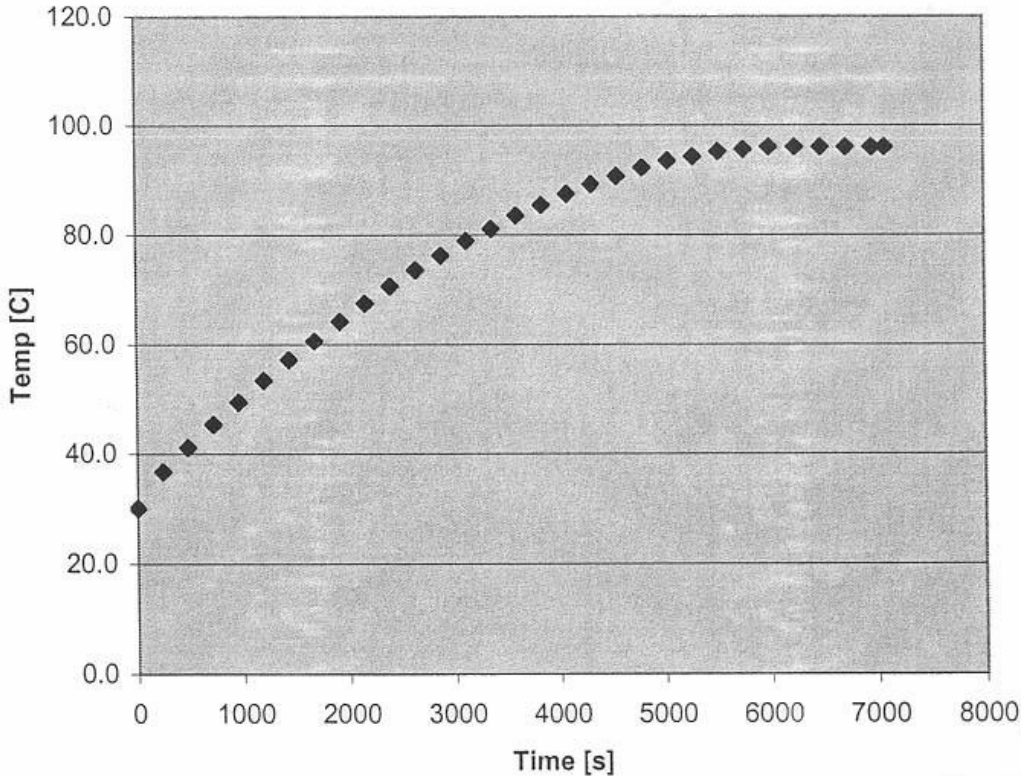

Comparing the two graphs above, we find that the Solar Cookit performed very well, comparable to the Funnel Cooker. We should note that in both cases, we used a canning jar (pressurised) supported by a wire stand. We found that the wire stand improves the performance of the Solar Cookit significantly and hope that this support stand will be used in countries where the Solar Cookit is in use.

In tests where the use of the clear plastic disk was tested against the oven-bag, an aluminium pot was used in the disk-set-up. In these tests, the cooker with an oven bag outperformed the cooker using a plastic disk. On 10 August, 2001, a test was run which compared the disk/pot set-up against the oven-bag/jar set-up. Both cookers follow similar heating paths with time, but the oven-bag/jar did slightly better. Due to the higher mass of the jar compared to the mass of the aluminium pot, and the much higher heat capacity of the water, the average power output for the oven-bag/jar was 39.8 ± 1.4 W, while the disk/pot put out $30.3 \text{ W} \pm 1.2$ W. The efficiency of the oven-bag/jar was 14.7% and the efficiency of the disk/pot set-up was 10.4% for this test. This is also partly due to the pressure-cooker effect that the canning jar produces. Though this is a considerable efficiency difference, the disk/pot set-up did very well in subjective tests where food was actually cooked and tasted. In all cases where the disk/pot set-up was used to cook food, the food cooked in about the same amount of time. The ease of the disk/pot set-up is also an important consideration. Overall, in tests where food was cooked, the disk/pot set-up was preferred over the oven-bag/jar set-up.

Conclusions:

As many countries are depleting their natural resources due to increased population and the resulting deforestation, methods other than burning wood are needed to cook food and pasteurise water. Solar

cookers provide a sustainable technology that relies on the sun's free energy. We report several advances to make them better. The need for cheap and effective solar cookers is very great and growing.

The Solar Funnel Cooker has been designed to meet the growing need by being inexpensive and effective. We determined that the Solar CookKit was nearly as effective when a rabbit-wire stand was used to support the cooking vessel. By collecting time vs. temperature data, quantitative analysis has been done. This analysis approach is useful for further development of the cookers.

Several areas of research were explored in 2001. Two finishes were tested for the reflector, a matt finish and a mirror finish. The benefits of the matt over the mirror finish are:

- 1) The matt finish is easier to work over because the sun's glaring reflection is diffused, and
- 2) the matt finish out-performs the mirror finish in temperature vs. time tests.

The method of closing off the cooker from convection current was tested and compared with an alternative method – a clear plastic disk. The use of a pot rather than a canning jar was also tested. Though the present oven-bag/jar method does outperform the disk/pot method, the disk/pot method is easier to use and seems to be nearly as efficient. Finally, we showed that a wire-mesh stand is a considerable improvement over the use of a wooden block or other opaque stand for the cooking vessel. We join with our fellow researchers around the world in pursuing further development of solar cookers, particularly to benefit people in developing countries.

References:

- [1]. Jones, Steven E. et al., BYU. [2]. Wattenberg, Frank. Montana State University. 1996.
[2]. Wattenberg, Frank. Montana State University. 1996.

Recent Advances in Solar Water Pasteurisation

Boiling isn't necessary to kill disease microbes



The main purpose of solar cookers is to change sunlight into heat which is then used to cook foods. We are all familiar with how successful solar cookers are at cooking and baking a wide variety of foods. In this article I want to consider using the heat in solar cookers for purposes other than cooking. My main focus will be solar water pasteurisation, which can complement solar cooking and address critical health problems in many developing countries.

The majority of diseases in developing countries today are infectious diseases caused by bacteria, viruses, and other microbes which are shed in human faeces and polluted water which people use for drinking or washing. When people drink the live microbes, they can multiply, cause disease, and be shed in faeces into water, continuing the cycle of disease transmission.

World-wide, unsafe water is a major problem. An estimated one billion people do not have access to safe water. It is estimated that diarrhoeal diseases that result from contaminated water kill about 2 million children and cause about 900 million episodes of illness each year.

Boiling contaminated water

How can infectious microbes in water be killed to make the water safe to drink? In the cities of developed countries this is often guaranteed by chlorination of water after it has been filtered. In developing countries, however, city water systems are less reliable, and water from streams, rivers and some wells may be contaminated with human faeces and pose a health threat. For the billion people who do not have safe water to drink, what recommendation do public health officials offer? The only major recommendation is to boil the water, sometimes for up to 10 minutes. It has been known since the time of Louis Pasteur 130 years ago that heat of boiling is very effective at killing all microbes which cause disease in milk and water.

If contaminated water could be made safe for drinking by boiling, why is boiling not uniformly practised? There seem to be five major reasons:

- 1) people do not believe in the germ theory of disease,
- 2) it takes too long,
- 3) boiled water tastes bad,
- 4) fuel is often limited or costly,
- 5) the heat and smoke are unpleasant.

Some examples of the cost of boiling water are worth mentioning. During the cholera outbreak in Peru, the Ministry of Health urged all residents to boil drinking water for 10 minutes. The cost of doing this would amount to 29% of the average poor household income. In Bangladesh, boiling drinking water would take 11% of the income of a family in the lowest quartile. In Jakarta, Indonesia, more than \$50 million is spent each year by households for boiling water. It is estimated that in the city of Cebu in the Philippines, population about 900,000, about half the families boil their drinking water, and the proportion is actually higher for families that obtain their water from an unreliable chlorinated piped supply. Because the quantities of fuel consumed for boiling water are so large, approximately 1 kilogram of wood to boil 1 litre of water, and because firewood, coal, and coke are often used for this purpose, an inadequate water supply system significantly contributes to deforestation, urban air pollution, and other energy-related environmental effects.

If wood, charcoal, or dung is used as fuel for boiling water, the smoke creates a health hazard, as it does all the time with cooking. It is estimated that 400 to 700 million people, mainly women, suffer health problems from this indoor air pollution. As a microbiologist, I have always been perplexed as to why boiling is recommended, when this is heat far in excess of that which is necessary to kill infectious microbes in water. I presume the reason boiling is recommended is to make sure that lethal temperatures have been reached, since unless one has a thermometer it is difficult to tell what temperature heated water has reached until a roaring boil is reached. Everyone is familiar with the process of milk pasteurisation. This is a heating process which is sufficient to kill the most heat resistant disease causing microbes in milk, such as the bacteria which cause tuberculosis, undulant fever, streptococcal infections and Salmonellosis. What temperatures are used to pasteurise milk? Most milk is pasteurised at 71.7° C (161° F) for only 15 seconds. Alternatively, 30 minutes at 62.8° C (145° F) can also pasteurise milk. Some bacteria are heat resistant and can survive pasteurisation, but these bacteria do not cause disease in people. They can, however, spoil the milk, so pasteurised milk is kept refrigerated.

There are some different disease microbes found in water, but they are not unusually heat resistant. The most common causes of water diseases, and their heat sensitivity, are presented in Table 1. The most common causes of acute diarrhoea among children in developing countries are the bacteria *Escherichia coli* and *Shigella* SD. and the Rotavirus group of viruses. These are rapidly killed at temperatures of 60° C or greater.

Solar water pasteurisation

As water heats in a solar cooker, temperatures of 56° C and above start killing disease-causing microbes. A graduate student of mine, David Ciochetti, investigated this for his master's thesis in 1983, and concluded that heating water to 66° C in a solar cooker will provide enough heat to pasteurise the water and kill all disease causing microbes. The fact that water can be made safe to drink by heating it to this lower temperature - only 66° C - instead of 100° C (boiling) presents a real opportunity for addressing contaminated water in developing countries.

Testing water for faecal contamination

How can one readily determine if the water from a well, pump, stream, etc. is safe to drink? The common procedure is to test the water for bacterial indicators of faecal pollution. There are two groups of indicators which are used. The first is the coliform bacteria which are used as indicators in developed countries where water is chlorinated. Coliform bacteria may come from faeces or from plants. Among the coliform bacteria is the second indicator, *Escherichia coli*. This bacterium is present in large numbers in human faeces (approximately 100,000,000 per gram of faeces) and that of other mammals. This is the main indicator used if water is not chlorinated. A water source containing 100 *E. coli* per 100 ccs poses a substantial risk of disease.

The standard method of testing water for the presence of coliforms and *E. coli* requires trained personnel and a good laboratory facility or field unit which are usually not present in developing countries. Thus, water supplies are almost never tested.

A new approach to testing in developing countries

In 1987, the Colilert MPM Test (CLT) was introduced as the first method which used a defined substrate technology to simultaneously detect coliforms and *E. coli*. The CLT comes as dry chemicals in test tubes containing two indicator nutrients: one for coliforms and one for *E. coli*. The CLT involves adding 10 ml of water to a tube, shaking to dissolve the chemicals, and incubating at body temperature for 24 hours. I prefer incubating tubes under my belt against my body. At night I sleep on my back and use night clothes to hold the tubes against my body.

If no coliform bacteria are present, the water will remain clear. However, if one or more coliforms are present in the water, after 24 hours their growth will metabolise ONPG and the water will change in colour from clear to yellow (resembling urine). If *E. coli* is among the coliform bacteria present, it will metabolise MUG and the tube will fluoresce blue when a battery-operated, long-wave ultraviolet light shines on it, indicating a serious health hazard. I have invited participants at solar box cooker workshops in Sierra Leone, Mali, Mauritania, and Nepal to test their home water supplies with CLT. One hundred and twenty participants brought in samples. In all four countries, whether the water was from urban or rural areas, the majority of samples contained coliforms, and at least half of these had *E. coli* present. Bacteriological testing of the ONPG and MUG positive tubes brought back from Mali and Mauritania verified the presence of coliforms/*E. coli* in approximately 95% of the samples. It is likely that soon the Colilert MPN test will be modified so that the test for *E. coli* will not require an ultraviolet light, and the tube will turn a different colour than yellow if *E. coli* is present. This will make the test less expensive and easier to widely use in developing countries to assess water sources.

Effect of safe water on diarrhoea in children

What would be the effect if contaminated water could be made safe for drinking by pasteurisation or boiling? One estimate predicts that if in the Philippines, families at present using moderately contaminated wells (100 *E. coli* per 100 ml) were able to use a high-quality water source, diarrhoea among their children would be reduced by over 30%. Thus, if water which caused a MUG (+) test were solar pasteurised so it would be clear, this would help reduce the chance of diarrhoea, especially in children.

Water pasteurisation indicator



How can one determine if heated water has reached 65° C? In 1988, Dr. Fred Barrett (USDA, retired) developed the prototype for the Water Pasteurisation Indicator (WAPI). In 1992, Dale Andreatta, a graduate engineering student at the University of California, Berkeley, developed the current WAPI. The WAPI is a polycarbonate tube, sealed at both ends, partially filled with a soybean fat which melts at 69° C

("MYVEROL" 18-06K, Eastman Kodak Co., Kingsport, TN 37662). The WAPI is placed inside a water container with the fat at the top of the tube. A washer will keep the WAPI on the bottom of the container, which heats the slowest in a solar box cooker. If heat from the water melts the fat, the fat will move to the bottom of the WAPI, indicating water has been pasteurised. If the fat is still at the top of the tube, the water has not been pasteurised.

The WAPI is reusable. After the fat cools and becomes solid on the bottom, the fish line string is pulled to the other end and the washer slides to the bottom, which places the fat at the top of the tube. Another pasteurisation indicator has been developed by Roland Saye which is based on expansion of a bi-metal disc which is housed in a plastic container. This also shows promise and is in the early testing stages. The WAPI could be useful immediately for people who currently boil water to make it safe to drink. The WAPI will indicate clearly when a safe temperature has been reached, and will save much fuel which is currently is being wasted by excessive heating.



[Editor's note: Using Beeswax & Carnauba Wax to Indicate Temperature: In SBJ #15 we discussed using beeswax, which melts at a relatively low 62° C, as an indicator of pasteurisation. We have now found that mixing a small amount of carnauba was with the beeswax (~1:5 ratio) raises the melting temperature of the beeswax to 70° - 75° C. Carnauba wax is a product of Brazil and can be bought in the US at woodworking supply stores. Further testing needs to be done to confirm that the melting point remains the same after repeated re-melting.

Different strategies for solar water pasteurisation

The solar box cooker was first used to pasteurise water. David Ciochetti built a deep-dish solar box cooker to hold several gallons of water. At this time of the year in Sacramento, three gallons could be pasteurised on our typical sunny days.

Dale Andreatta and Derek Yegian of the University of California, Berkeley, have developed creative ways to greatly increase the quantity of water which can be pasteurised, as we will hear about at this conference.

I am also excited about the possibility of pasteurising water using the simple solar panel cookers. By enclosing a dark water container in a polyester bag to create an insulating air space, and by using lots of reflectors to bounce light onto the jar, it is possible to pasteurise useful amounts of water with a simple system. It takes about four hours for me to pasteurise a gallon of water in the summer with the system I am using. Solar panel cookers open up enormous possibilities for heating water not only for pasteurisation, but also for making coffee and tea, which are quite popular in some developing countries. The heated water can also be kept hot for a long time by placing it in its bag inside an insulated box. In the insulated container I use, a gallon of 80° C water will be approximately 55° C after 14 hours. Water at a temperature of 55° C will be about 40° C after 14 hours, ideal for washing/shaving in the morning.

I will close with some advice from the most famous microbiologist, who pioneered the use of vaccinations in the 1890s: Louis Pasteur. When he was asked the secret of his success, he responded that above all else, it was persistence. I will add that you need good data to be persistent about, and we certainly have that with solar cookers; the work in Sacramento, Bolivia, Nepal, Mali, Guatemala, and wherever else the sun shines. Continued overuse of fuel-wood is non-sustainable. We need to persist until the knowledge we have spreads and becomes common knowledge world-wide.

For questions or comments contact Dr. Robert Metcalf at.

Dr. Robert Metcalf
1324 43rd St.
Sacramento, California 95819 USA.

IDEXX Laboratories, Inc. makes the Colilert kit and is located at this address:

IDEXX Laboratories, Inc.
One IDEXX Drive
Westbrook, ME 04092
USA
Voice: (800) 321-0207 or (207) 856-0496
Fax: (207) 856-0630

Editor's Note: Testing Water in Developing Countries

The Colilert system makes it possible to test water without the need for a laboratory. IDEXX Laboratories, the manufacturer, recommends that you use five test tubes for each sample. Bob Metcalf explains that five tubes would comprise 50 ml, which is the minimum sample size permitted by US law. This is an unrealistically high standard by which to judge the water in developing countries where you are examining water that is already being drunk, in spite of the fact that it may be making people sick. By using a single test tube (10 ml) there is a very small chance that your sample missed the small number of bacteria that might have been present.

IDEXX Laboratories will also tell you that you need an incubator to achieve valid results. Again, Bob Metcalf tells us that all that is needed is to keep the tubes close to your body for 36 hours, since body temperature is the correct incubation temperature.

What you are actually measuring in the test is the presence of 1) coliform bacteria, and 2) E. coli, a type of coliform bacteria that is largely found in faecal matter. A positive test for coliform bacteria might be due to coliform bacteria that has washed off of plant leaves, and thus be fairly innocuous. A positive test for E. coli, however, would indicate that any bacteriological contamination was from a faecal source, which might also contain Giardia, cholera, or other serious infectious microbes.

This document is published on The Solar Cooking Archive at <http://solarcooking.org/pasteurisation/metcalf.htm>.

The Solar Puddle

A new water pasteurisation technique for large amounts of water



The lack of clean drinking water is a major health problem in the developing world. To reduce this health risk ways of producing clean water at an affordable cost are needed, and people need to be educated about germs and sanitation, lest they accidentally re-contaminate their clean drinking water. Recently, several of us at the University of California at Berkeley have attacked the first of these requirements. Previous issues of this newsletter have included stories about our water pasteurisation indicator and our flow-through water pasteuriser based on a design by PAX World Service. In this article we describe a new low-cost device that pasteurises water.

For those not familiar with the pasteurisation process, if water is heated to 149° F (65° C) for about 6 minutes all the germs, viruses, and parasites that cause disease in humans are killed, including cholera and hepatitis A and B. [Ed. We have reports from the field that at 145° F (63° C) in a solar puddle, bacterial growth might actually be increased. Since this temperature is very close to the minimum pasteurisation temperature mentioned in this article, we suggest that you heat the water to a higher

temperature and perform tests before adopting a solar puddle as your method of pasteurisation]. This is similar to what is done with milk and other beverages. It is not necessary to boil the water as many people believe. Pasteurisation is not the only way to decontaminate drinking water, but pasteurisation is particularly easy to scale down so the initial cost is low.

The new device is called a solar puddle, and it is essentially a puddle in a greenhouse. One form of the solar puddle is sketched in the figure below, though many variations are possible.

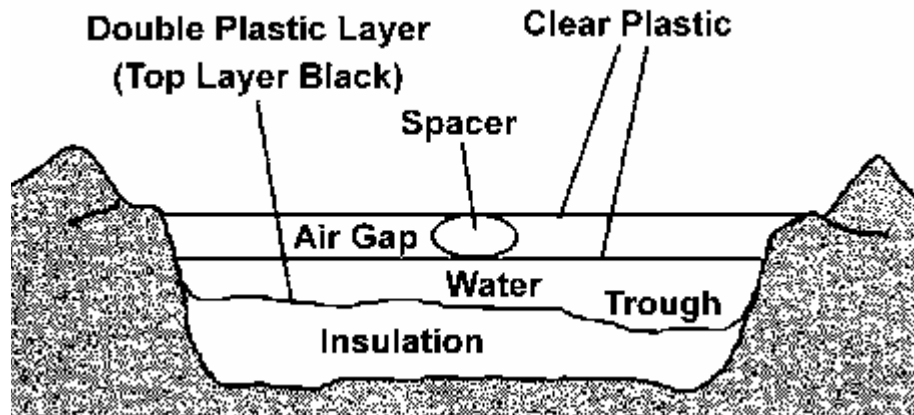

One begins by digging a shallow pit about 4 inches deep. The test device was a "family-size" unit, about 3.5 feet by 3.5 feet, but the puddle could be made larger or smaller. If the puddle is made larger there is more water to pasteurise, but there is also proportionately more sunshine collected. The pit is filled with 2 to 4 inches of solid insulation. We used wadded paper, but straw, grass, leaves, or twigs could be used. This layer of insulation should be made flat, except for a low spot in one corner of the puddle.

Put a layer of clear plastic and then a layer of black plastic over the insulation with the edges of the plastic extending up and out of the pit. Two layers are used in case one develops a small leak. We used inexpensive polyethylene from a hardware store, though special UV stabilised plastic would last longer. Put in some water and flatten out the insulation so that the water depth is even to within about 0.5 inch throughout the puddle, except in the trough which should be about 1 inch deeper than the rest. Put in more water so that the average depth is 1 to 3 inches depending on how much sunshine is expected.

A pasteurisation indicator (available from Solar Cookers International at 916/455-4499) should go in this trough since this is where the coolest water will collect. Put a layer of clear plastic over the water, again with the edges extending beyond the edges of the pit. Form an insulating air gap by putting one or more spacers on top of the third layer of plastic (large wads of paper will do) and putting down a fourth layer of plastic, which must also be clear. The thickness of the air gap should be 2 inches or more. Pile dirt or rocks on the edges of the plastic sheets to hold them down. The puddle is drained by siphoning the water out, placing the siphon in the trough and holding it down by a rock or weight. If the bottom of the puddle is flat, well over 90% of the water can be siphoned out.

Once the puddle is built it would be used by adding water each day, either by folding back the top two layers of plastic in one corner and adding water by bucket, or by using a fill siphon. The fill siphon should NOT be the same siphon that is used to drain the puddle, as the fill siphon is re-contaminated each day, while the drain siphon MUST REMAIN CLEAN. Once in place the drain siphon should be left in place for the life of the puddle.

The only expensive materials used to make the puddle are a pasteurisation indicator (about \$2 for the size tested). All of these items are easily transportable, so the solar puddle might be an excellent option for a refugee camp if the expertise were available for setting them up.

Many tests were done in the spring and summer of this year in Berkeley, California. On days with good sunshine the required temperature was achieved even with 17 gallons of water (2 1/2 inch depth). About 1 gallon is the minimum daily requirement per person, for drinking, brushing one's teeth, and dish washing. With thinner water layers higher temperatures can be reached. With 6 gallons (1 inch depth) 176° F was achieved on one day.

The device seems to work even under conditions that are not ideal. Condensation in the top layer of plastic doesn't seem to be a problem, though if one gets a lot of condensation the top layer should be

pulled back to let the condensation evaporate. Small holes in the top layers don't make much difference. The device works in wind, or if the bottom insulation is damp. Water temperature is uniform throughout the puddle to within 2° F.

After some months the top plastic layers weaken under the combined effects of sun and heat and have to be replaced, but this can be minimised by avoiding hot spots. Another option would be to use a grade of plastic that is more resistant to sunlight. The two bottom layers of plastic tend to form tiny tears unless one is very careful in handling them, (that is why there are two layers on the bottom). A tiny hole may let a little water through and dampen the solid insulation, but this is not a big problem.

There are many variations of the solar puddle. We've been able to put the top layer of plastic into a tent-like arrangement that sheds rain. This would be good in a place that gets frequent brief showers. Adding a second insulating layer of air makes the device work even better, though this adds the cost of an extra layer of plastic. As mentioned the device can cover a larger or smaller area if more or less water is desired. One could make a water heater by roughly tripling the amount of water so that the maximum temperature was only 120° F or so, and this water would stay warm well into the evening hours. This water wouldn't be pasteurised though. One could help solve the problem of dirty water vessels by putting drinking cups into the solar puddle and pasteurising them along with the water. The solar puddle could possibly cook foods like rice on an emergency basis, perhaps in a refugee camp.

*You can contact
Dr. Dale Andreatta
S. E. A. Inc.
7349 Worthington-Galena Rd.
Columbus, OH 43085
(614) 888-4160 FAX (614) 885-8014*

This document is published on The Solar Cooking Archive at <http://solarcooking.org/pasteurisation/puddle.htm>.

Important web link: <http://solarcooking.org/plans/default.htm>

The “Easy Lid” Solar Cooker.

Designed by Chao Tan and Tom Sponheim



Although designs for cardboard cookers have become more simple, fitting a lid can still be difficult and time consuming. In this version, a lid is formed automatically from the outer box.

Making the Base

Take a large box and cut it in half as shown in Figure 1. Set one half aside to be used for the lid. The other half becomes the base.

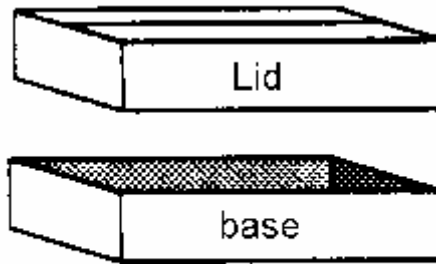

Figure 1

Fold an extra cardboard piece so that it forms a liner around the inside of the base (see Figure 2).

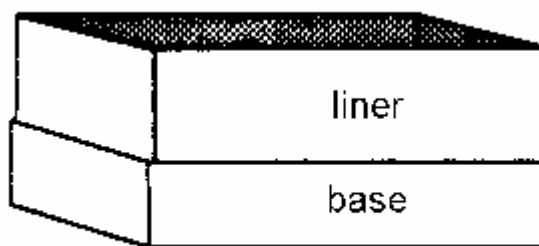

Figure 2

Use the lid piece as shown in Figure 3 to mark a line around the liner.

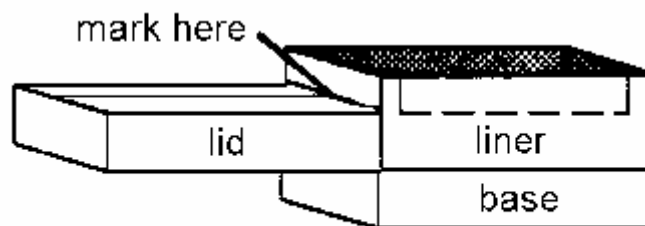

Figure 3

Cut along this line, leaving the four tabs as shown in Figure 4.

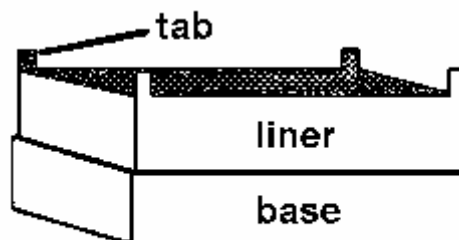

Figure 4

Glue aluminium foil to the inside of the liner and to the bottom of the outer box inside.

Set a smaller (inner) box into the opening formed by the liner until the flaps of the smaller box are horizontal and flush with the top of the liner (see Figure 5). Place some wads of newspaper between the two boxes for support.

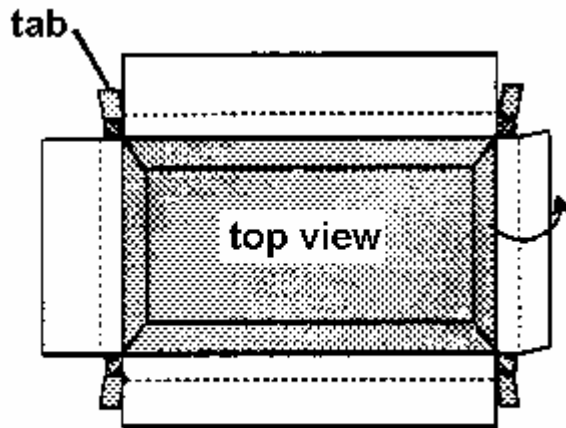

Figure 5

Mark the underside of the flaps of the smaller box using the liner as a guide.

Fold these flaps down to fit down around the top of the liner and tuck them into the space between the base and the liner (see Figure 6).

Fold the tabs over and tuck them under the flaps of the inner box so that they obstruct the holes in the four corners (see Figure 6).

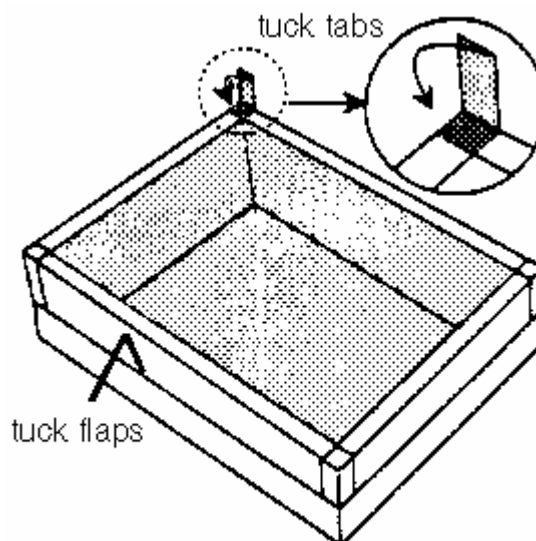

Figure 6

Now glue these pieces together in their present configuration.

As the glue is drying, line the inside of the inner box with aluminium foil.

Finishing the Lid

Measure the width of the walls of the base and use these measurements to calculate where to make the cuts that form the reflector in Figure 7. Only cut on three sides. The reflector is folded up using the fourth side as a hinge.

Glue plastic or glass in place on the underside of the lid. If you are using glass, sandwich the glass using extra strips of cardboard. Allow to dry.

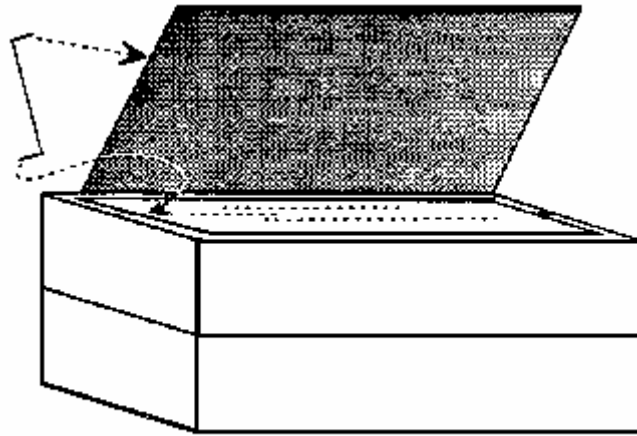

Figure 7

Bend the ends of the wire as shown in Figure 7 and insert these into the corrugations on the lid and on the reflector to prop open the latter.

Paint the sheet metal (or cardboard) piece black and place it into the inside of the oven.

Improving Efficiency

Glue thin strips of cardboard underneath the sheet metal (or cardboard) piece to elevate it off of the bottom of the oven slightly.

Cut off the reflector and replace it with one that is as large as (or larger than) the entire lid. This reflects light into the oven more reliably.

Turn the oven over and open the bottom flaps. Place one foiled cardboard panel into each airspace to divide each into two spaces. The foiled side should face the centre of the oven.

For more information contact:

Solar Cookers International
1919 21st St., Suite 101
Sacramento, CA 95811 USA

Drinking Water Collection Systems.

Getting adequate drinking water can often be a problem as there are many places where the local water supply is heavily contaminated with poisons, deadly organisms or both. While it is definitely much better to drink purified water than seriously contaminated water, it should be understood that most of the systems mentioned here, produce either distilled water or something very close to distilled water. Drinking distilled water for more than a few weeks is not ideal as distilled water is able to dissolve almost anything and it can do that perfectly well inside your body, removing essential minerals and other important items. So, if possible, avoid drinking distilled water for lengthy periods of time unless there is no other option other than seriously contaminated water carrying diseases and poisons.

One solution introduced for an area where there is almost never any rainfall is particularly interesting. This region gets fogs in the early morning, so plastic devices were constructed to take advantage of this fact. The devices were like plastic clothes brushes with long, slender vertical projections. The fog encountering these, condenses into freshwater droplets on the surface of these vertical fronds and run down the fronds into a plastic tank which forms the base of the device. No moving parts. No input power needed, but the result is large quantities of drinking water every morning. There is very little evaporation from the tanks, due to the small surface area of the stored water:

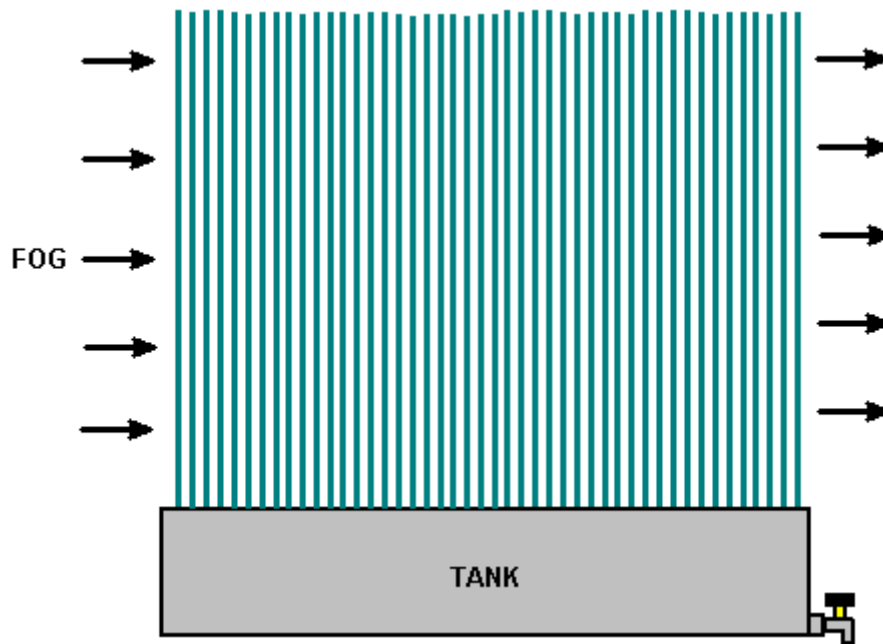

This effect is very noticeable on foggy days where trees drip water extensively due the fog depositing moisture on the leaves and branches.

An emergency measure where water is needed, is to fasten a clean plastic bag around a branch of a tree. Trees lift a large amount of water through their root systems and a good deal of that water exist from the leaves of the tree. The plastic bag intercepts that moisture loss and collects it as clean water:

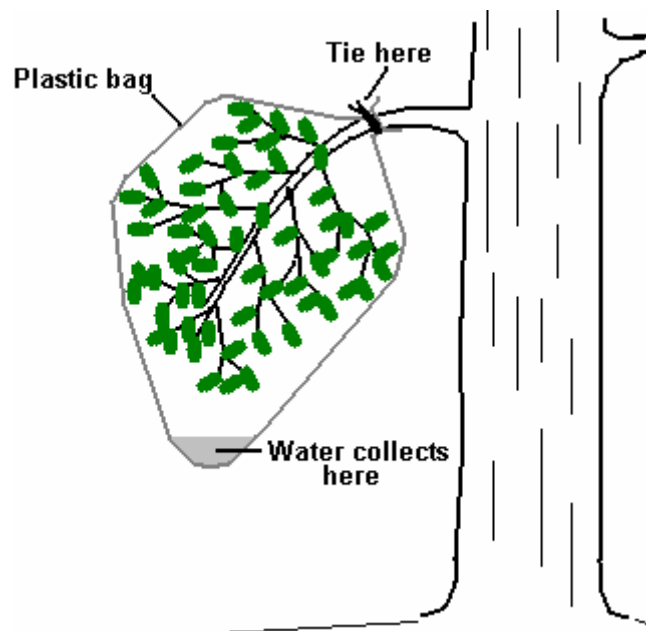

Another emergency measure is to use a clean plastic sheet and a hole dug in the ground. A clean container is placed in the centre of the hole and the plastic sheet used to cover the hold. The sheet is held around the edges of the hole with stones or any other suitable heavy material – bricks, timber, etc. A weight is then placed in the centre of the plastic sheet, pulling it down into a slope in every direction and forming an inverted peak over the container:

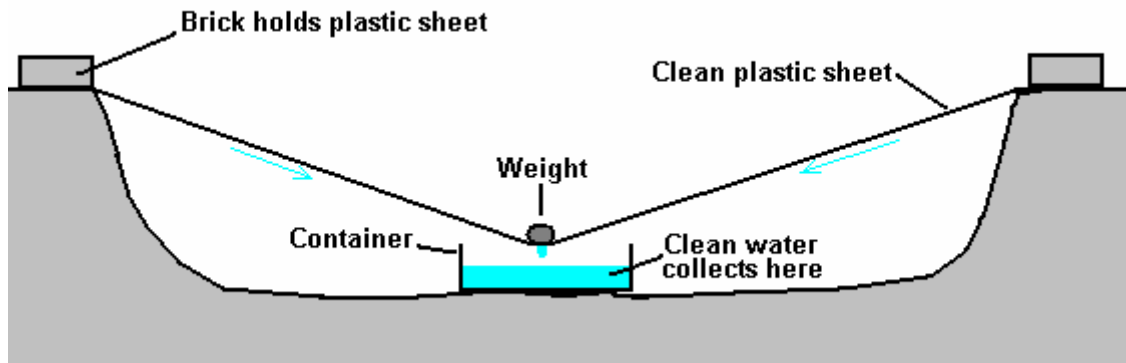

The area under the plastic sheet is heated by the greenhouse effect. Moisture also comes from the earth inside the enclosed hole. The moisture in the air in the cavity condenses on the underside of the plastic sheet. But as the plastic sheet is shaped into an inverted pyramid due to the weight just above the container, the water runs down and drips into the container. Again, no input power required and no moving parts.

While these methods produce good quality water which is effectively distilled water, it should not be considered to be sterile and immediately ready for human consumption, even though any risk from drinking it 'as-is' is likely to be very low. There will always be air-borne pathogens, and the 'clean' components used to collect the water in the first place may not be as clean as was thought. The same applies to the excellent quality water produced by dehumidifiers, where the inner working surfaces cannot be considered sterile after the equipment has been used for any length of time. To raise the water quality, boiling briefly, microwaving the water or it to UV radiation should kill any remaining harmful organisms in the water and make it fit for consumption.

Applying these same methods on a more permanent basis, leads to the construction of devices of the following type:

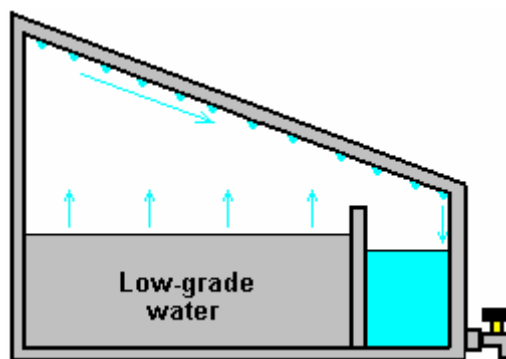

There can be many variations on this shape. These devices are generally built either with glass lids or the whole construction in acrylic sheet. Here, the greenhouse effect heats the inside of the box, causing evaporation of the water inside. This condenses on the walls and lid of the box, where it runs down and into the clean-water section. Please remember that after a long period of use, the device needs to be cleaned very carefully and to deal with air-borne bacteria, the water could be treated briefly with UV light.

This particular design can be further enhanced as shown on the <http://www.permapak.net/solarstill.htm> web site, where the heating inside the box is upgraded by using black high-temperature silicone to coat the inside of the bottom of the case. The black material absorbs sunlight particularly well and so helps to heat the water. Another enhancement is to place a reflector, possibly made from aluminium foil, behind the unit in order to increase the amount of sunlight or UV radiation reaching the water inside the box:

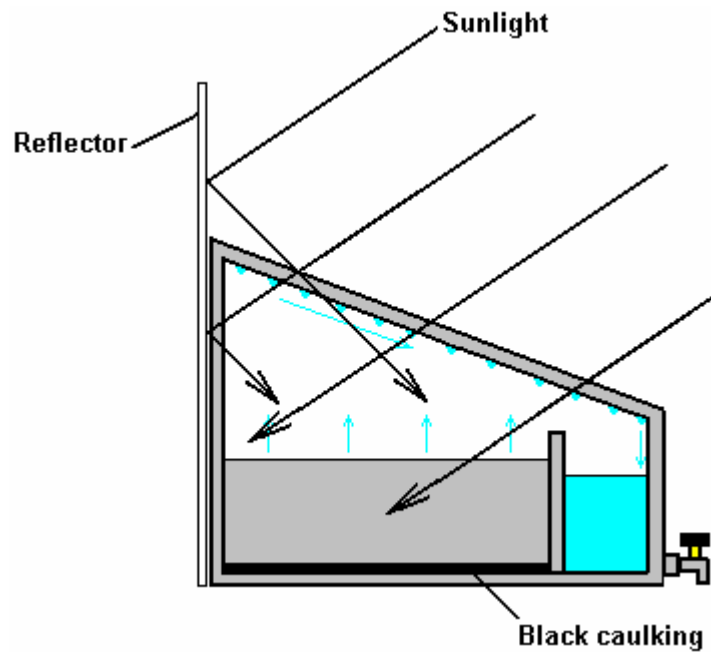



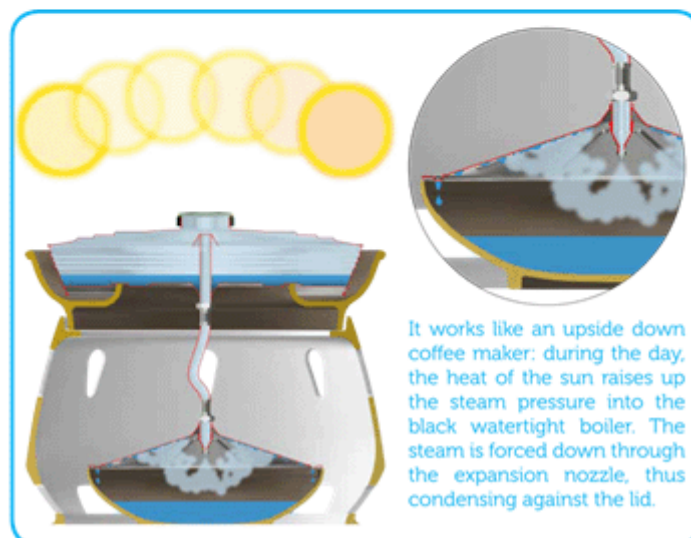
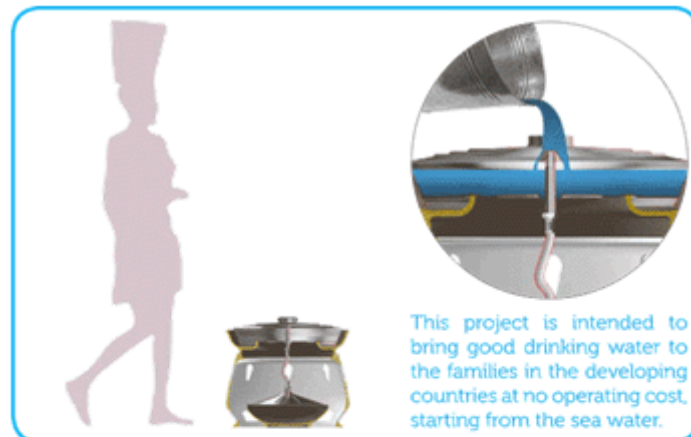

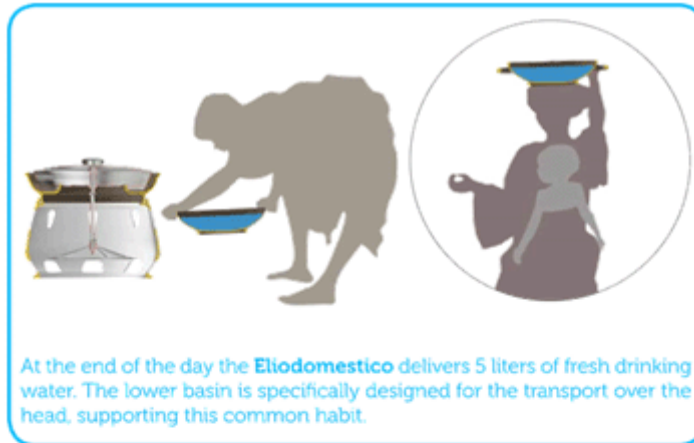
The web site <http://www.gabrielediamanti.com/projects/eliodomestico---how-does-it-work/> shows details of what is considered to be a very effective, low-cost unit aimed at undeveloped countries. Please visit that site where there is a 'Donations' button which allows you to support this excellent work. The designer Gabriele Diamanti says "Eliodomestico is an open project, free to the people who need it. I would really appreciate if you would like to help me in the development of this project!". It works like this:



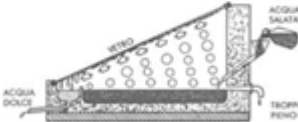

Eliodomestico is entirely made from poor, widely available materials. The technologies involved in the production are very simple and popular. This also make the maintenance much easier.

- No electricity
- No filters
- Very easy maintenance
- Good impact on the local economy
- No impact on the environment

Eliodomestico	Normal solar still
 	 
5 liters/day	3 liters/day
	
estimated cost: 50\$	average cost: 100\$

Eliodomestico is intended to be an open project





attribution - non commercial - share alike

Very simple systems:

It is usually presumed that quite a bit of expenditure and construction is needed to make a solar still which will purify water. That is not necessarily the case. Here is a design which can cost nothing and which can work well in a sunny location:

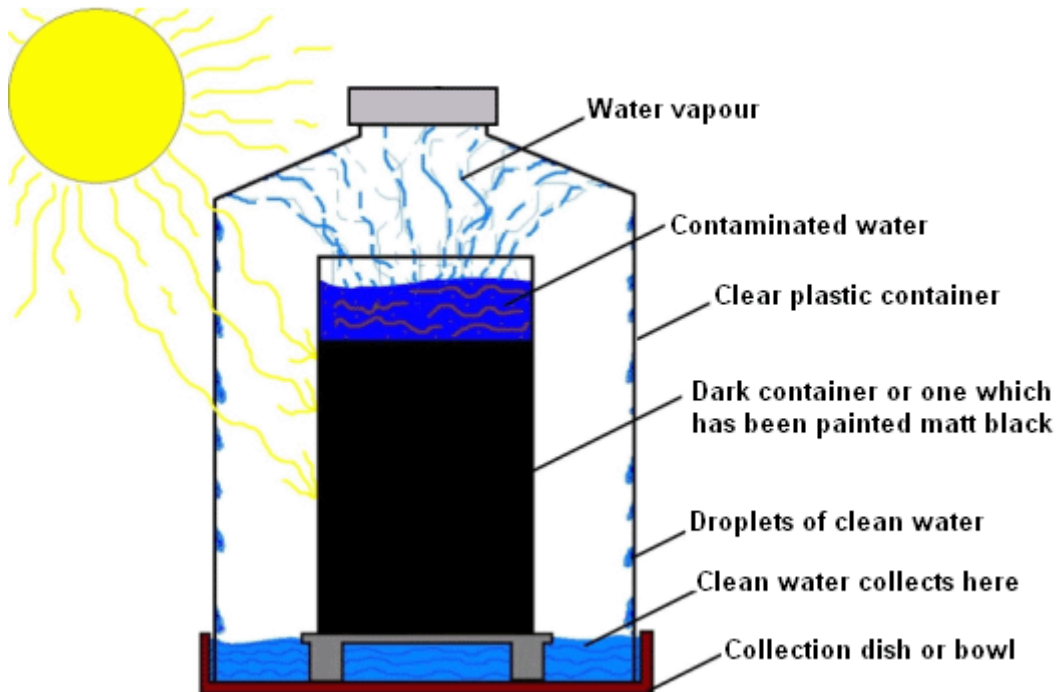

This arrangement could hardly be more simple than it is. An inner container is used and it is made either from a dark material or is painted black, preferably, matt black as a shiny black reflects more of the light falling on it than a matt black surface does. In the diagram above, the black stops well short of the top of the inner container, but that is only to show the liquid inside the container and in fact, the inner container will be dark from top to bottom. Because of this dark colour, the liquid inside the inner container gets hotter than the air outside it (which is hotter than the air outside the outer container, due to the greenhouse effect). There is considerable evaporation from the inner container, but as it can't escape, it forms droplets on the inside of the outer container and these droplets slide down and collect at the bottom of the container, forming a reservoir of distilled water which is safe to drink. The construction of this still can be from things which are already to hand. For example, the bottom can be cut off a transparent plastic drinks bottle and used to cover a dark glass drinks bottle standing in an ordinary bowl, as shown here:



It is, of course, essential for the outside of the glass bottle and the inside of the plastic bottle to be completely clean so that they do not contaminate the purified water.

Another variation on this is to use a dark glass jar inside a plastic storage jar, again, placed inside an ordinary bowl as shown here:



Alternatively, a plastic jar with a screw lid can be used upside down and the lid used to replace the bowl. The inner container in this case, happens to be plastic. The capacity of the lid limits the amount of clean water which can be produced at any one time, unless the lid is carefully removed and a larger bowl used to catch the clean water (which means that it would have been easier to use the bowl instead of the lid):



On a larger scale: US patents 2,996,897 (1960) from Elmer Grimes:

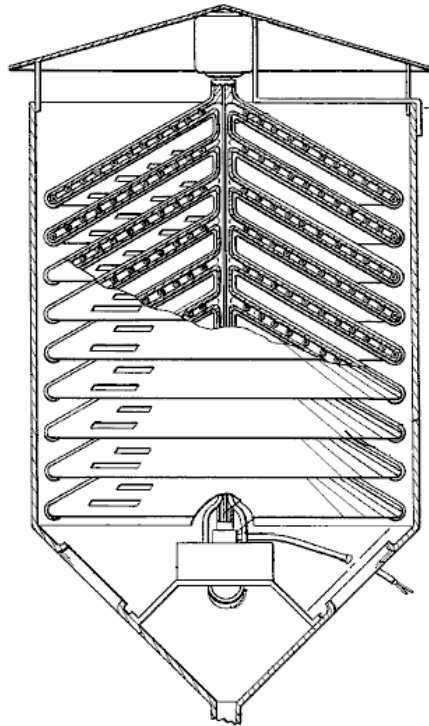

and Patent 4,418,549 (1982) from Calice Courneya:

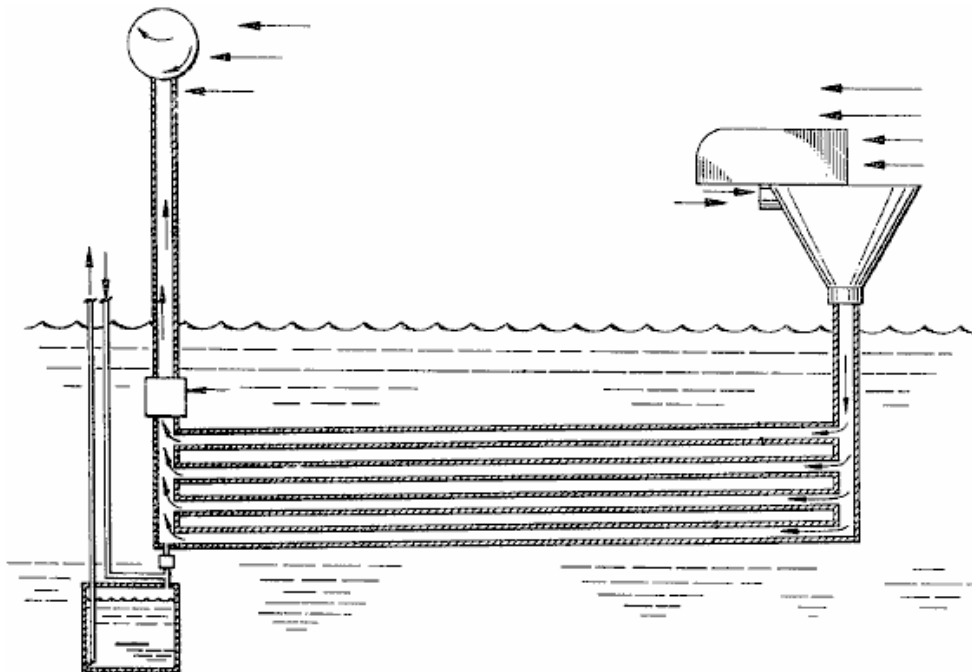

show methods of extracting large amounts of drinking water from moisture in the air:

Another system is using a large Fresnel lens to distill water which is not suitable for drinking. This is possible using the most simple equipment of two glass bottles and a piece of copper tubing. If it is still there, the video at <http://www.youtube.com/watch?v=aXjMAItCMl0> shows the method, though I must admit that I would prefer to take the liquid which he drinks and pass it through the system again to improve it's quality further.

Toribio Bellocq's Water Pump.

A serious problem for farmers and individuals is the cost of pumping water up from a borehole or well. While the combined Lever / Pendulum system of Veljko Milkovic described in Chapter 4 can reduce the amount of effort required by a substantial margin, there are other methods which could be useful.

It was originally thought that water could not readily be pumped to a greater height than 32 feet or so unless the pump was located at the bottom of the pipe. Toribio Bellocq demonstrated in 1924 that this is actually not the case and that water can be pumped to any height using a pump mounted at the top of a vertical pipe. He showed a working system to the Patent Office where an 80-foot vertical pipe was used to demonstrate the principle and having proved the point, he was granted US Patents 1,730,336, and 1,730,337, and later, US Patent 1,941,593 in which he describes chamber devices which can enhance the sonic wave operation.

Toribio's system is very straightforward. He places a one-way ball valve at the bottom of the vertical pipe (item **V** in the diagram below). A crank rod is then used to vibrate piston **C** in its pumping cylinder. The pumping cylinder has no valves and the piston stroke is very short. Both the pipe and the pump cylinder are filled with water before the operation is begun.

The rapid movement of the piston creates a pressure wave in the water in the pipe. The pressure wave causes the water pressure inside the pipe to rise and fall rapidly. This altering water pressure at the one-way valve at the bottom of the pipe, causes water to be drawn into the pipe when the pressure is low and the valve prevents the water flowing out again when the pressure rises.

This repeating action causes water to be pumped up the vertical pipe and out through an adjustable valve **R**. When the pumping action is timed correctly, there is an almost continuous flow of water from the pipe.

Toribio quotes an example in his patent, where the vertical pipe has an internal diameter of one inch, placed in a well where the water is twenty metres below the ground level. The valve opening is 30 mm and the sealing ball of the valve has a diameter of about 38 mm and contained in an ordinary cage which allows some 20 mm of vertical movement of the valve.

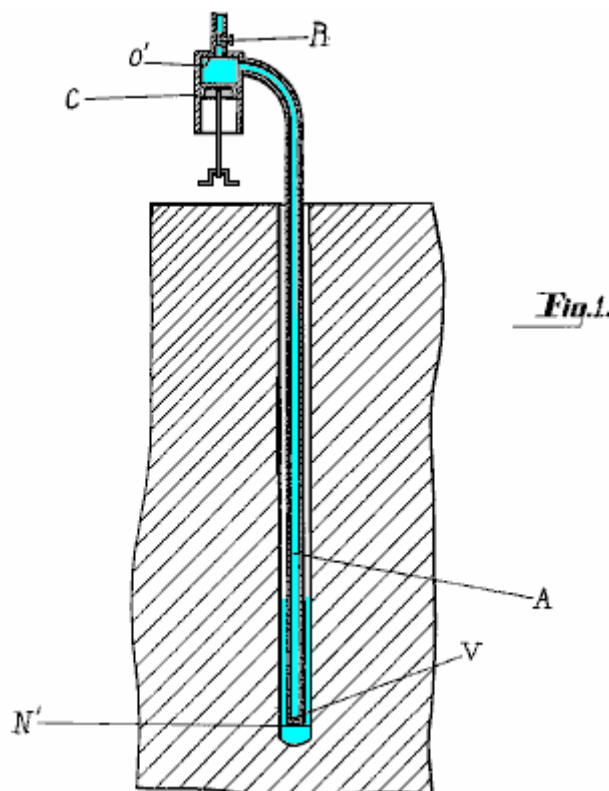

With this arrangement, the piston at the surface has a diameter of 50 mm and a stroke of 38 mm and is driven by an electric motor at about 360 rpm. The outflow pipe has an internal diameter of half an inch and the valve **R** is used to control the rate of flow out of the system. When the valve is adjusted correctly, a continuous flow is achieved and the flow rate is about 1,000 litres per hour (265 US gallons per hour, or 220

Imperial gallons per hour). It is important that the initial filling of the pipe and fully-open piston avoids getting any air trapped along with the water. The compressor cylinder can be horizontal or vertical. The well can be of any depth and there is no need for the pipe to be straight or vertical. When the system is adjusted correctly, there is little or no wear on the valve at the bottom of the pipe. The liquid pumped does not have to be water.

Richard Dickinson's Water Pump.

US Patent 2,232,678 of 1937, show a very similar system with a piston being driven in a cylinder without valves, creating a pressure wave in the vertical pipe which has a similar one-way valve at the bottom of the pipe. Interestingly, no mention of Bellocq's patent is made. Dickinson's patent drawing of the system outline is shown here:

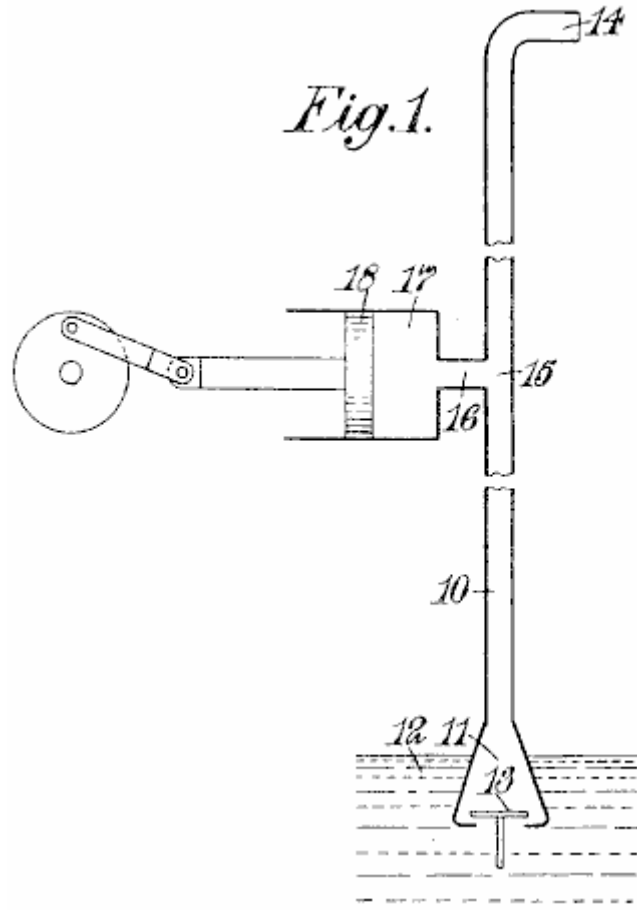

Arthur Bentley's Water Pump.

The grandson of the car designer, Arthur Bentley has some 34 patents to his name, one of which (US 4,295,799) is very much like Toribio Bellocq's pump system. Richard Bruner writing in the Calgary Herald newspaper in 1989, tells how a prototype of the Bentley design was tested on a Navajo reservation in Arizona. Driven by four solar panels, a flow rate of 120 US gallons per hour was achieved, (about half that of Bellocq's rate at 20 metres depth), though the depth of the Navajo well was not mentioned. The manufacturers claim that the pump can operate at depths of up to 4,000 feet.

Neither this Bentley patent nor his earlier patent 3,804,557 makes any mention of Bellocq which seems somewhat strange, especially with the marked apparent similarity between the designs. Again, we see here, a piston being used to generate an acoustic wave in the vertical pipe and a series of one-way valves at the bottom of the tube being used to trap the rising column of water and prevent it from flowing out of the bottom of the pipe again. A variation in this patent is the addition of a spring loaded bottom section to the pipe which is alternately compressed and expanded by the sound waves as part of the pumping process as shown in the following diagrams:

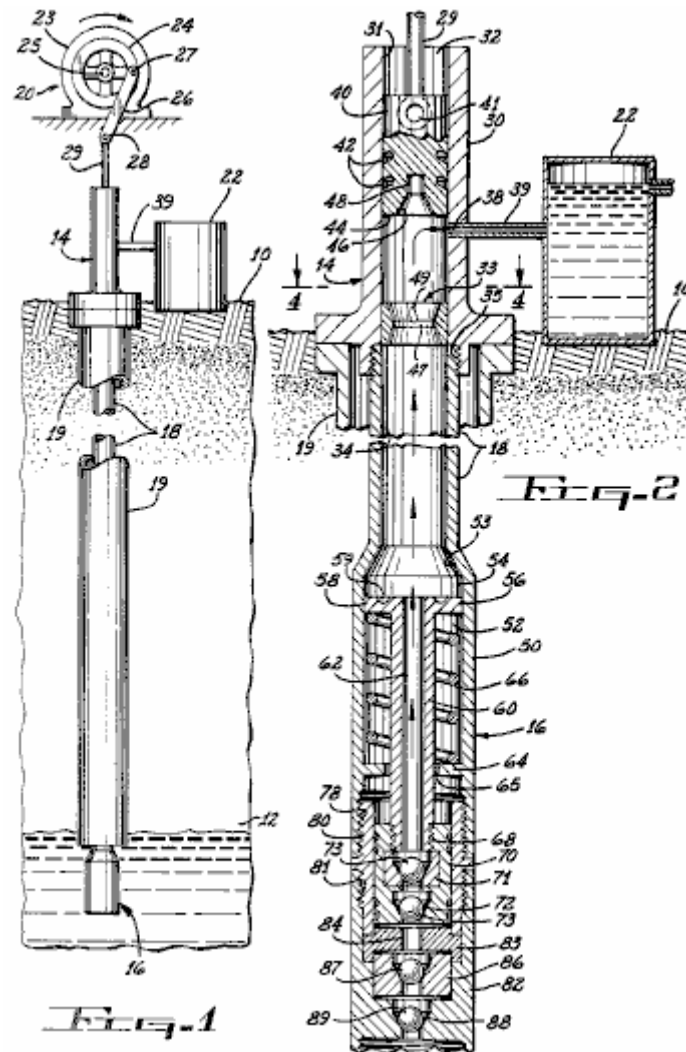

The Ram Self-Powered Pump.

In hilly areas, it is frequently necessary to pump water up to locations where it is needed. These locations are usually considerably higher than the source of water. There is a simple device called a "Ram Pump" which is powered by water flow alone and needs no other form of power. In a way, it operates very much like the pumps just described, in that water flowing into a pressure chamber causes fluctuating pressure which with just two valves, and no other moving parts, pumps water to a considerable height.

A Ram Pump can be used if there is a fast-flowing stream of clean water, and more than 50% of the water flow into the pump can be lifted to a higher level. The remainder of the water flows back into the stream at a point lower down. These pumps are readily available commercially and interestingly, they have a COP of infinity as the user does not have to supply any input power and yet substantial pumping power is produced for an unlimited period. As this is a standard Engineering technique, nobody gets upset at the thought of 'perpetual motion' or 'free-energy' even though the pump can go on pumping for years with absolutely no fuel being burnt. This is energy being drawn from the environment in the same way as a self-powered compressed air engine draws energy from the environment, and yet, the compressed air engine is considered to be "unbelievable" while the Ram Pump is accepted without question. Could there be a certain degree of bias being seen here? The power operating the pump comes from the water flowing down hill. The water arrives at this height by falling as rain. The rain gets up there by evaporation caused by water being heated by the sun. So, bottom line, the pumping power comes from the sun.

If a fast-flowing stream is not available but the terrain allows it, then a Ram Pump feeding system can be built. Ideally, there should be a drop of at least two metres (six feet) on the inlet pipe. This creates a fast flow into the pump by feeding it through a steeply sloping intake pipe, like this:

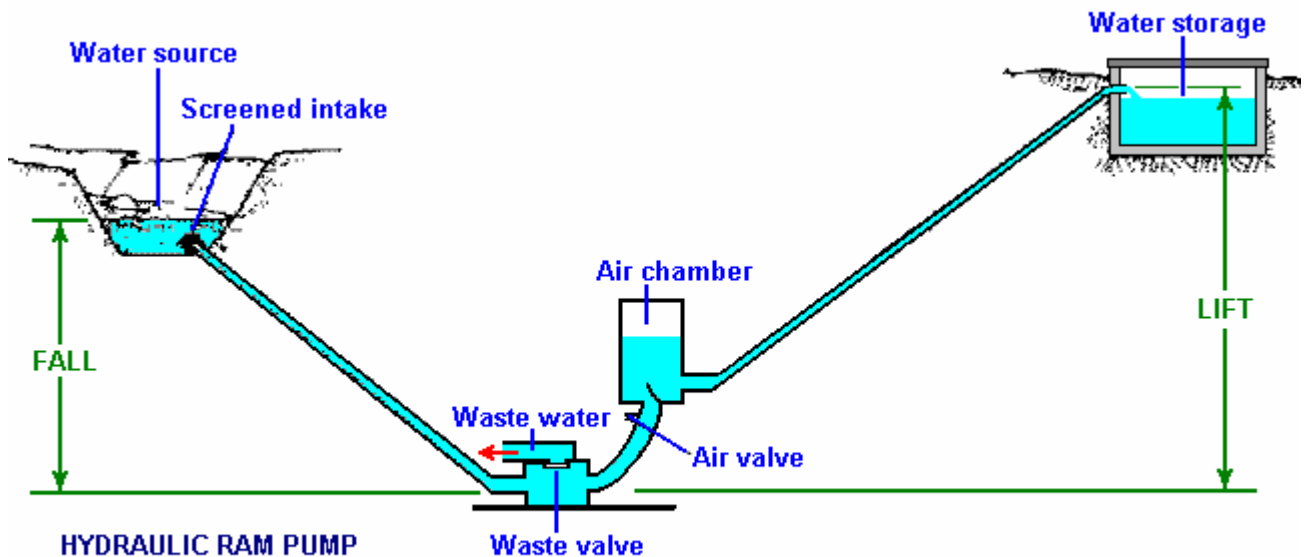

Diagram from: www.thefarm.org/charities/i4at/lib2/hydrpump.htm

The performance of a Ram Pump is impressive even though it has only two moving parts. With an input fall of just four metres and a small flow rate of just three litres per minute, a Ram Pump can deliver 69 litres per day to a massive height of 100 metres vertically above the pump. Or, 159 lpd to 60 metres above the pump, or 258 lpd to a height of 40 metres above the pump. This is impressive for such a simple device.

It operates by the water rushing into the air chamber. This raises the pressure until the valve at the base of the chamber slams closed. The increased pressure in the chamber pushes water out of the delivery outlet, lowering the pressure again. While this is happening, the closed valve causes a 'water-hammer' wave of reverse pressure which pushes excess water out of the 'waste' pipe and pushes water back up the intake pipe. When the pressure wave in the intake pipe dissipates, the water rushes back down the pipe, pushing the valve at the base of the air chamber, open again, to repeat the cycle. This oscillating pressure wave causes the pumping action, very much in the same way as the previous pumps which use a mechanical oscillator pump as no free-flowing water is available to create the oscillation.

Commercial ram pumps have an efficiency of about 66%. The calculation of performance is:

$$D = (S \times F \times E) / L$$

Where:

- D** = The quantity of water in litres delivered in 24 hours.
- S** = The quantity of water, in litres per minute, fed to the pump.
- F** = The height in metres of the water source above the pump intake.
- E** = The efficiency of the pump (assume 33% for home built units).
- L** = The height in metres, of the supply outlet above the pump.

Reproduced here by kind permission of US AID 1982 from the web site shown in the diagram above, is a table of values, calculated from the formula above, and assuming the 66% efficiency of a commercial unit. The input flow for these numbers is a tiny 1 litre per minute trickle. This is less than the hydroxy gas rate produced by the Smack's Booster shown in Chapter 10, so in practice, you will be multiplying the numbers in this table by a realistic number of inflow litres per minute.

Litres Delivered over 24 Hours

Working Fall (m)	Lift - Vertical Height to which Water is Raised Above the Ram (m)											
	5	7.5	10	15	20	30	40	50	60	80	100	125
1.0	144	77	65	33	29	19.5	12.5					
1.5		135	96.5	70	54	36	19	15				
2.0		220	156	105	79	53	33	25	19.5	12.5		
2.5		280	200	125	100	66	40.5	32.5	24	15.5	12	
3.0			260	180	130	87	65	51	40	27	17.5	12
3.5				215	150	100	75	60	46	31.5	20	14
4.0				255	173	115	86	69	53	36	23	16
5.0				310	236	155	118	94	71.5	50	36	23
6.0					282	185	140	112	93.5	64.5	47.5	34.5
7.0						216	163	130	109	82	60	48
8.0							187	149	125	94	69	55
9.0							212	168	140	105	84	62
10.0							245	187	156	117	93	69
12.0							295	225	187	140	113	83
14.0								265	218	167	132	97
16.0									250	187	150	110
18.0									280	210	169	124
20.0										237	188	140

Discouraging Mosquitoes and Small Flies

Maurice Cottrell (whose work is in chapter 11) presents what is a quite remarkable effect. He says:



What it is, is a church door in Ireland, surrounded with a white plastic pipe filled with water. When in Palenque in Mexico Maurice found that the local people discouraged flies, particularly mosquitoes and very

small flies, by hanging polythene bags filled with water, from the lintels of their open doors. They do not know why, but doing that discourages flies from entering the doorway.

Maurice considered the effect and his opinion is that small flies can be injured by raindrops and so they have learned to avoid them. A falling raindrop has an electrogravitic effect due to the hydrogen atoms in the water, and flies which can see in the ultraviolet spectrum, can detect that effect around water and their instinct makes them avoid water – whether falling as droplets or not. Large bluebottle flies do not seem to be affected, but there is a definite effect with smaller flies.

If a doorway is surrounded with a 1-inch (25 mm) diameter plastic pipe filled with water, as seen in the picture above, then Maurice believes that the resulting effect is like this:

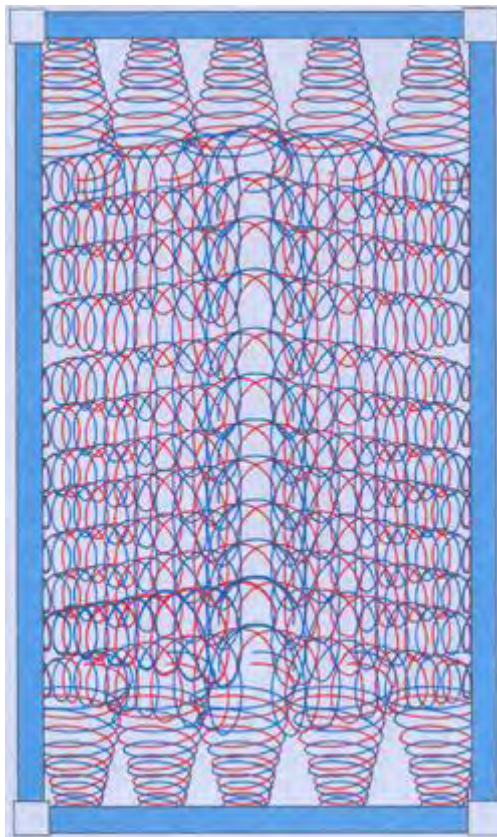

Here, gravity waves spread out from the water and create an effective barrier all the way across the doorway, discouraging the smallest flies, including midges. Obviously, any opening can be surrounded with a water-filled pipe, and not just doorways. While this is not a renewable energy device as such, it is a method which could well be useful where serious diseases are carried by mosquitoes.

Wave Power.

Although not generally thought of as an option for personal use, wave power does have a high potential, although, like wind power and unlike tidal power, not always available. We tend to think of wave power systems as being large scale and very expensive, but that is not always the case. At its most basic level, most wave power system uses the varying distance between the surface of an ocean or sea and some fixed point on land or the sea bed.

Ideally, there should be a minimum of moving parts. One neat design uses a simple rectangular concrete housing with an electrical generator mounted above sea level. The generator being above sea level is easy to reach for maintenance or replacement and there are no moving parts underwater. It is a very simple design which can be built quite easily. In its most simple form, it is just a rectangular box with an underwater opening:

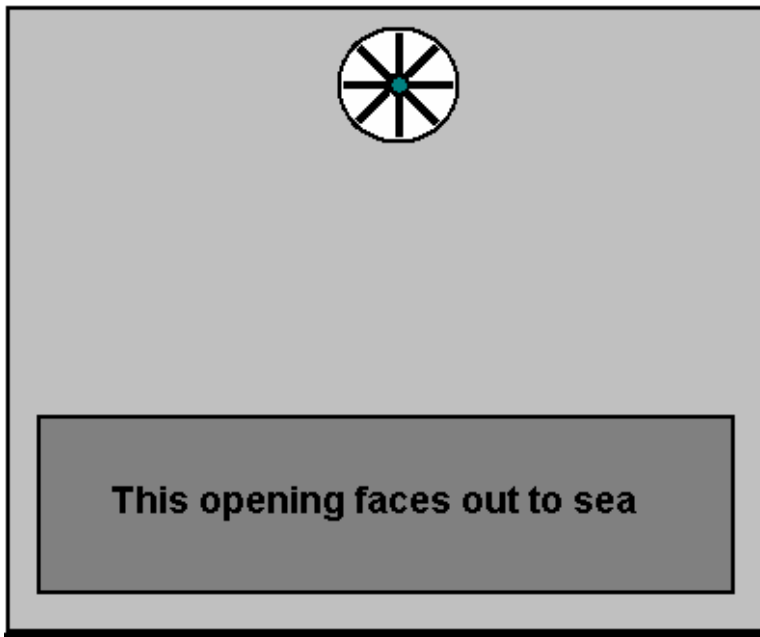

FRONT VIEW

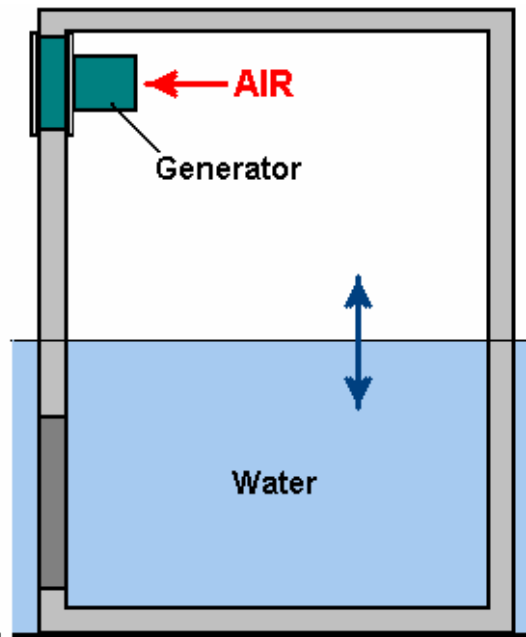

SIDE VIEW

Here, a large opening allows the sea to flow into the structure which makes the water level inside the box move up and down with the wave motion outside. As a wave passes by, it compresses the air inside the box and the air is driven out through the generator opening, spinning the generator blades in the same way as a wind-powered generator has its blades spun by the wind.

Some generators operate well with the air flowing backwards and forwards through the blades, generating electricity no matter which way the blades are spun. With a generator which works better with just one direction of spin, then a large flap valve is installed and it allows air to flow into the structure when the water level is falling but closes immediately the water level starts rising again.

Even though this style of wave power generator is so simple, it works very well in practice, provided that the vertical dimensions are arranged so that the top of the underwater opening is below the lowest neap tide and the bottom of the generator opening is above the highest spring tide. A baffle arrangement can be used to protect the generator from spray and storm debris. There is no need to have the structure full width above the water level:

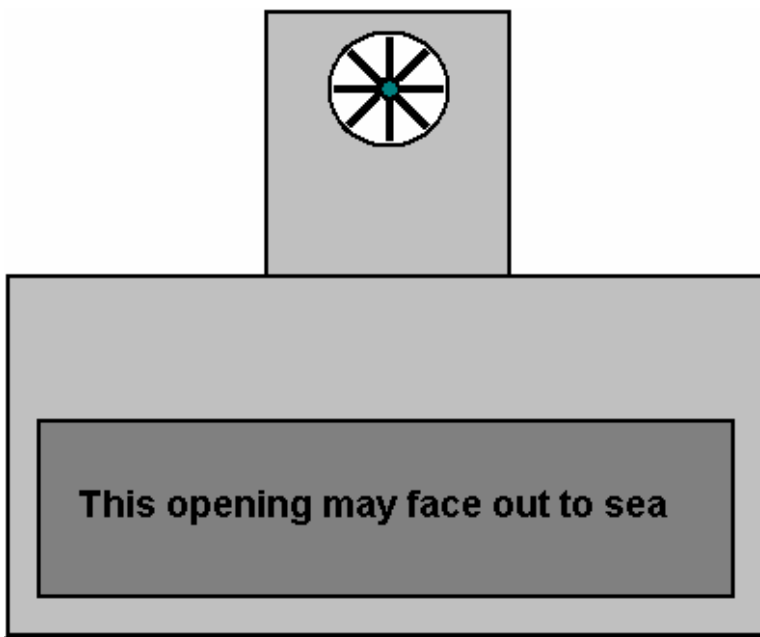

FRONT VIEW

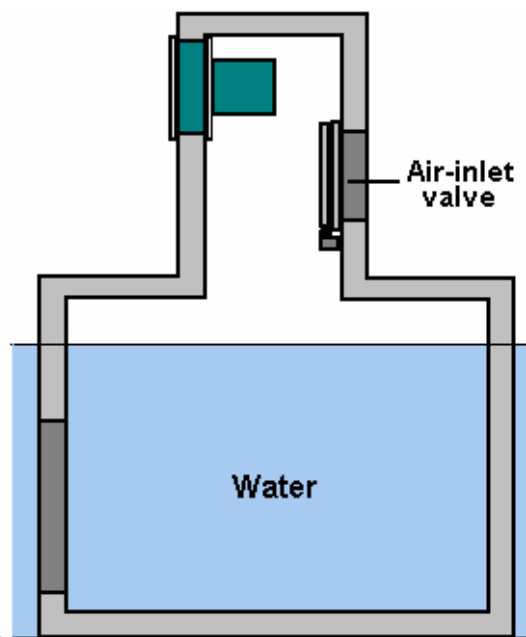

SIDE VIEW

This has the very considerable advantage that the area of the water surface inside the structure is very much larger than the cross-sectional area of the generator housing column and so the air rushes out through the generator much faster than the wave rises. This amplification factor can be increased by increasing the length of the base of the unit, further enlarging the water surface area inside the structure. If wave action is frequently very strong, then it may be preferred to have the undersea opening facing inshore or sideways in order to reduce the amount of material driven into it by very strong surges.

Another fairly simple wave power generator system design which is based on simple principles, was suggested on Stefan Nystrom's website which has been discontinued. It is called the "WaveReaper" system. It operates using a large number of separate buoys. Plastic barrels are suggested as suitable buoys but almost any non-dangerous containers which will not corrode in the sea and which have a considerable internal volume, can be used in this system.

Each basic unit consists of a float, a pulley, a cable and a ratchet drive connection to the shaft of an electrical generator. The power provided by the movement of the buoy can be very substantial as sea water weighs a considerable amount. The connecting cable is kept taut by a heavy weight, and the cable runs over a pulley which is mounted on a shaft which connects to the shaft of the generator. Bicycle parts are suggested for this section of the drive as they are cheap and readily available in most places and they come with a toothed sprocket wheel which already has a suitable ratchet built into it.

The reason for the shaft is that a whole series of buoys are used. These buoys are positioned progressively further and further from the shore so that an incoming wave raises the buoys one after the other in a regular sequence. This means that while one buoy is letting its cable run back inshore (pulled by its inshore weight), one or more of the other buoys will be rising and applying drive to the shaft linked to the generator. This arrangement allows the generator shaft to receive a continuous drive. Having a heavy flywheel on this shaft is an added advantage as it will smooth out the repeated drive strokes provided by the buoys:

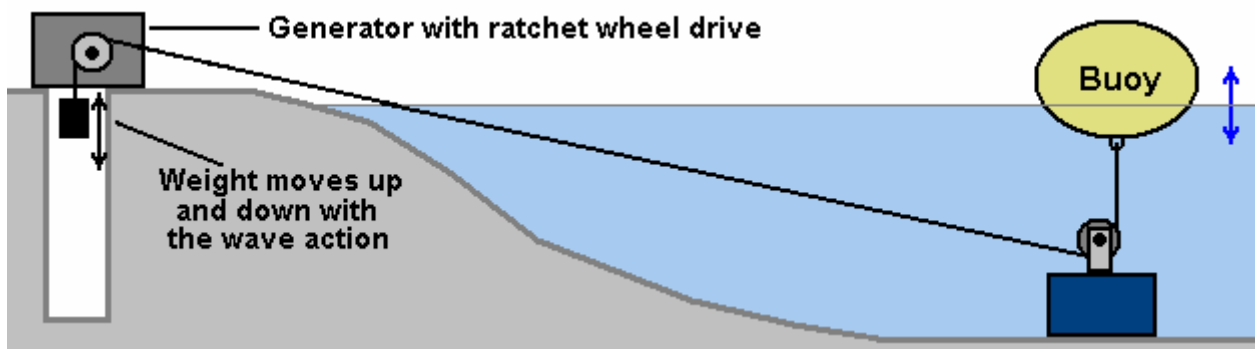

Having a sheaf of moving cables threaded through the sea near the shore is asking for a major tangle with seaweed and all kinds of other drifting material. Very sensibly then, Stefan suggests that the cables be housed in a protecting pipe. Considerable care needs to be taken to make sure that the cables do not rub against anything as the movement is constant and the forces involved are high. Each cable needs to have its own space keeping it clear of all the other cables and having a pulley mounted at any points where there is a change of direction.

To make maintenance easier, it is also suggested that these protecting pipes are not fixed in position but are themselves on a pulley system so that they can be hauled ashore:

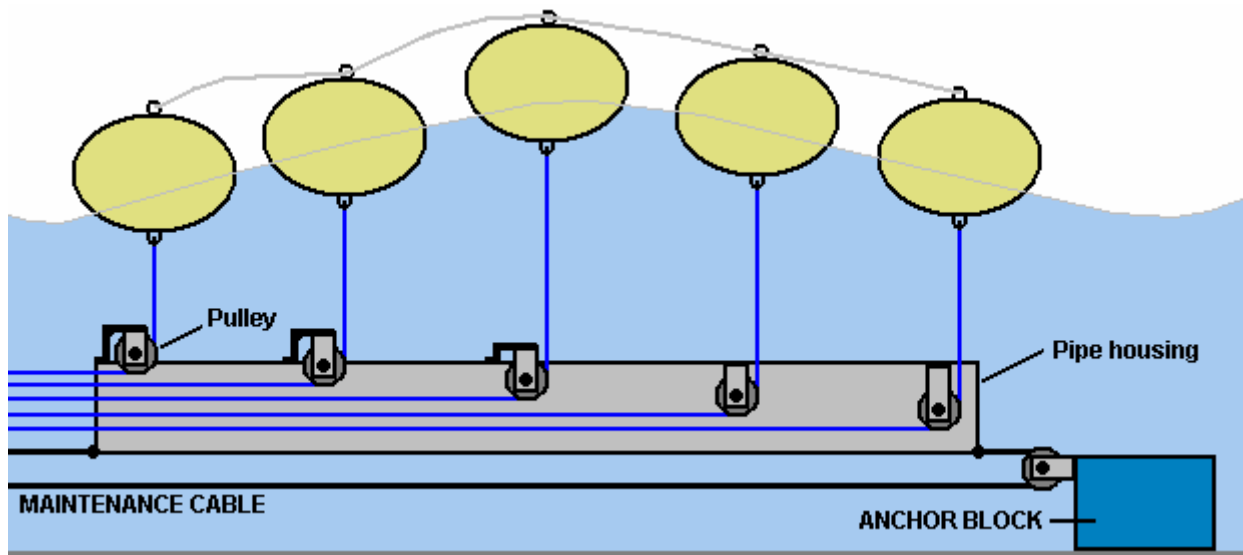

The buoys are also linked together loosely on top with a securing cord so that they always stay in a compact group, though there is little chance of any great sideways movement as the tension in the buoy cables is high. Stefan requests that anyone who constructs his design makes a donation via <http://www.o2gruppen.se/> though how that is done is by no means clear to me as there does not appear to be a "Donate" button on that website.

There are many other wave-power devices, some with excellent efficiencies, but most are not generally capable of construction by the average amateur. One example is the "Nodding Duck" design by Stephen Salter of Edinburgh in Scotland, and shown in the US patent 3,928,967 where the wave power is extracted by a raft-like construction with cam-shaped floats. These floats have a rippling movement on the surface of the water and the movement of each section relative to the other sections is used to generate power. This is not exactly a back-yard construction.

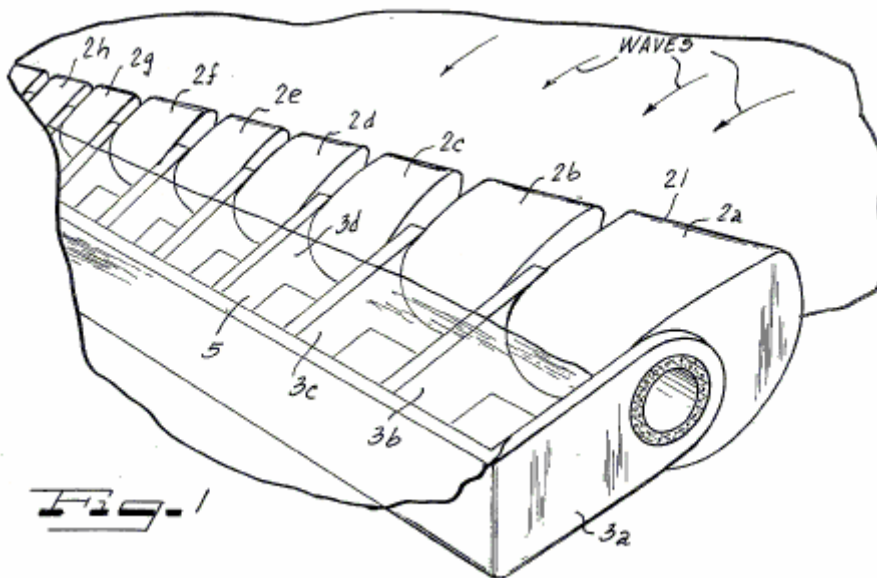

Other Systems.

Not included in this eBook, but on the website <http://www.free-energy-info.tuks.nl/> there are articles from the highly recommended Home Power website <http://www.homepower.com/home/> which are on this general topic. There is a system for producing blocks of ice using sun power alone and no other energy input at all:

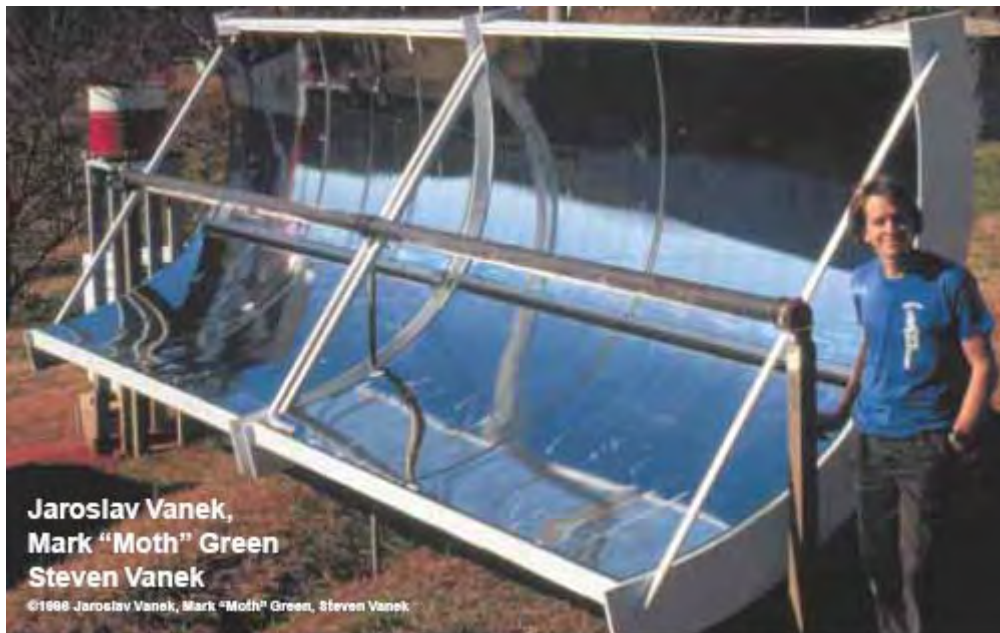

Above: Steven Vanek with his machine which uses solar thermal energy to make ice.

Also, a two-part article on Solar cooling, which concentrates on heat absorption with different colours, the strategic positioning of buildings and vegetation, practical roof overhangs and the like, to lower the temperature inside buildings in very hot locations.

There are articles is on cooking with hydrogen, heating your house with hydrogen and using hydrogen with a barbecue. On the Home Power site there is information on how to use solar power to heat household water and you may find the Google video on how to make your own hot-water solar panel interesting and useful. It makes sense to reduce your essential costs by doing a few simple things which help.

Cooling Using Heat.

Most of our current refrigerators use electricity to drive a compressor to achieve cooling. Here is a patent from Albert Einstein (whom you may have heard of) and Leo Szilard which uses heat to power refrigeration instead of electricity. It is US Patent 1,781,541 titled "Refrigeration" and dated 11th November 1930.

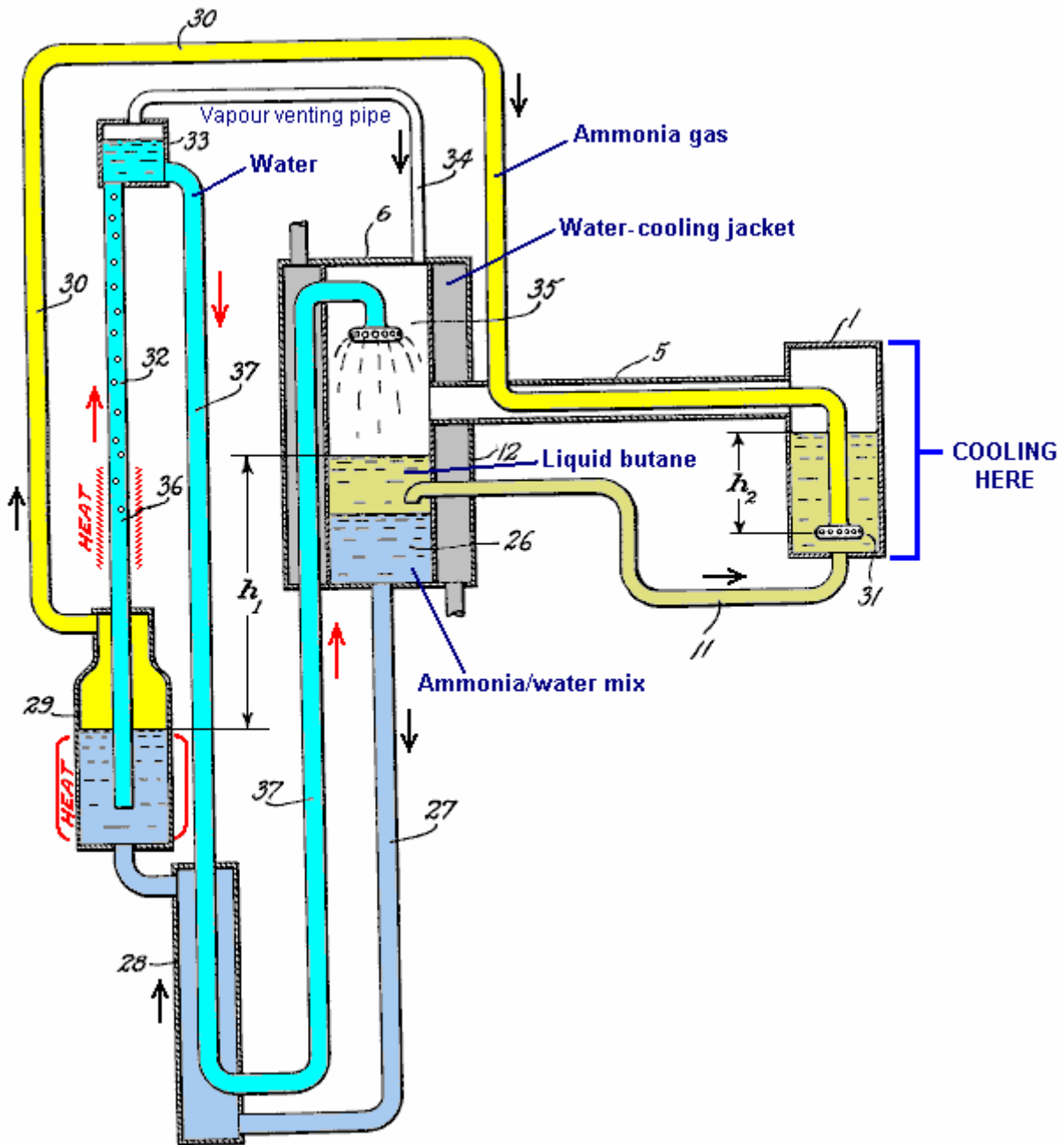

Our invention relates to the art of refrigeration and particularly to an apparatus and method for producing refrigeration where the refrigerant evaporates in the presence of an inert gas and more particularly, to the type disclosed in the Von Platen and Munters Patent No. 1,685,764 of 25th September 1928 and our British Patent No. 282,428.

The objects and advantages of our invention will be apparent from the following description considered in conjunction with the accompanying drawing which shows more or less diagrammatically, a preferred embodiment of our invention.

In the drawing, 1 is an evaporator which is normally placed inside the chamber which is to be cooled. A pipe 5 connects the upper part of evaporator 1 to the more intermediate portion of the condenser 6. Pipe 11 connects with the bottom of the evaporator 1 and extends into the condenser 6, at a level which is below the level of pipe 5. A cooling water jacket 12, surrounds the condenser and allows cooling water to flow through it.

Pipe 27 connects the bottom of the condenser 6, to the lower part of a heat-exchanger jacket 28. The upper part of jacket 28, is connected to the lower part of generator 29 which is heated by any suitable method. Pipe 30 connects the upper part of generator 29 to a point near the bottom of evaporator 1 where it

terminates in a distributor head **31**. Pipe **30** runs inside pipe **5** so that there is a heat exchange between the fluids in those two pipes.

Pipe **32** runs upwards from the lower part of generator **29** to connect with a container **33** which is positioned at a level which is above that of condenser **6**. A source of heat **36**, is applied to pipe **32** at a point above generator **29**. Pipe **37** runs down from container **33**, passing through the heat-exchanger jacket **28** and then on up to the top of condenser **6** where it terminates in a distributor head **35**. Pipe **37** runs inside the cooling water jacket **12** so that the fluid passing through it will be cooled as it flows. A venting pipe **34** connects the upper part of container **33** with the upper part of condenser **6**.

The operation of the apparatus is as follows:

A suitable refrigerant, for example, butane in liquid form, is held inside the evaporator **1**. An inert gas, such as ammonia, is introduced into evaporator **1** through pipe **30** and its distributor head **31**. The refrigerant evaporates in the evaporator in the presence of the inert gas due to the fact that the partial pressure of the refrigerant is reduced thereby and the resulting gaseous mixture passes through pipe **5** and into condenser **6**. Here, the mixture comes into intimate contact with an absorption liquid, for example, water, which is fed into the condenser through pipe **37** and its distributor head **35**. The ammonia gas is very soluble in water but the butane is quite insoluble, so the ammonia is absorbed into the water freeing the butane from the gaseous mixture. Thus, the butane assumes substantially the entire pressure inside the condenser, and that pressure is sufficiently high to cause its liquefaction at the temperature maintained by the cooling water.

The specific gravity of liquid butane is less than that of the solution of ammonia in water and so stratification of the two liquids occurs with the liquid butane floating on top of the ammonia solution **26**. The liquid butane passes from condenser **6**, through pipe **11**, and returns to evaporator **1**, where it is again evaporated and the cycle repeated.

Gravity causes the ammonia solution to flow from condenser **6** through pipe **27** and heat-exchanger jacket **28**, into generator **29**. Here, the application of heat causes the ammonia to be expelled from the solution in the form of a gas, which then passes through pipe **30** and distributor head **31**, into evaporator **1**, where it reduces the partial pressure of the butane, causing it to evaporate as already described.

Water, containing very little ammonia in solution, passes from generator **29** through pipe **32** where it is further heated by the source of heat **36**. This heating causes the formation of vapour in pipe **32** which lifts the liquid through this pipe and into container **33** and on from there under gravity through pipe **37** to condenser **6** and during its flow, this hot, low-concentration liquid is cooled by the heat-exchanger jacket **28**. It is further cooled by the cooling water in jacket **12**, and so reaches a condition where it can rapidly absorb ammonia in the condenser **6**. Vapour entering container **33** through pipe **32**, continues on its journey to the condenser **6** via the venting pipe **34**.

During the operation of this piece of equipment, the pressure existing in the various components is uniform with the exception of slight differences caused by columns of liquid needed to cause the fluids to flow. The pressure existing in generator **29** must be sufficiently greater than the pressure in the upper part of evaporator **1**, in order to make vapour flow through distributor head **31**. In other words, the pressure difference must be sufficient to overcome the liquid head marked h_2 . This excess pressure in the generator is balanced by the pressure created by the column of liquid marked h_1 in the drawing. This means that h_2 must be less than h_1 , otherwise there would be no flow.

This patent of Einstein and Szilard seems to indicate that any source of heat such as a fire or a solar oven, should be able to produce cooling using a device which has no moving parts. It would probably be necessary to provide a trickle of water through the water cooling jacket, but apart from that, it looks like a device which could be used effectively by people who live "off the grid" and have little or no access to electricity. All in all, it is an interesting design.

Solar Panels.

A very well-known method of producing electricity from what appears to be a renewable resource are solar panels. It hardly seems worth mentioning these as sales are so well promoted but it is possible that the problems with them are not understood. This is the most expensive way of producing electricity, and when there is a government scheme to cover one third or one half of the purchase price, it is quite likely that the chosen supplier has prices which are so high that it is cheaper to buy the panels direct from an outlet with competitive pricing rather than paying a much higher price with a subsidy.

What is often not realised is that solar panels have a working life span and will need replacement at some later date. The life is quite good, typically ten to fifteen years, but the price is so high that replacement costs must be allowed for. Solar panels are not the only part of your electrical system which will need replacing. Generally speaking, solar panels are used to charge batteries which then power equipment, usually by using an "inverter" which changes a DC battery voltage to a mains voltage AC supply. The big snag is that the frequently used lead-acid batteries generally have a lifespan of about four years. They are expensive, heavy and as they contain lead, they are not easy to dispose of (legally). This is a major recurring cost and disposal problem.

Another point which may not be realised is that the current which can be drawn from a battery without reducing its working life is very limited. The safe discharge rate is called the "C20" rate which just means that the allowable current is one which discharges the battery in a period of 20 hours. For example, if a new battery is rated as being a 100 Amp-hour ("100 Ahr") battery, then the safe discharge rate is 100 amps divided by 20, which is 5 amps. At twelve volts, a current of five amps is a power output of sixty watts. A washing machine needs about 2,200 watts for at least some of the time, so to power it (and nothing else at the same time) would take 37 of those 100 Ahr batteries. Could you conveniently house 37 large batteries? How much do you think it would cost to replace them every four years?

Another point which is often missed is that batteries are by no means 100% efficient and that means that you have to put more current into them than you can draw out of them afterwards. After some time in use, you may only get between 50% and 80% of the power back from the battery bank.

Please understand that I have nothing against solar panels and actually own three of them myself, but you need to be aware of the practical problems with using them and not imagine that buying them will give you free electricity for ever afterwards.

The next factor to be considered is the fact that the power "rating" of a panel such as "120 watts" is not the amount of power which will be provided by the panel. It will provide that amount of power IF it is positioned exactly square-on to very strong sunlight in a region near the Equator. If the panel is not aimed exactly at the sun, then the panel output will be considerably lower. The sun moves around at a rate of fifteen degrees per hour, so your panel will only be aimed directly at the sun for about four minutes unless you have it mounted on a rotating platform and you push the platform round slowly to face the sun at all times. While that sounds complicated, it is actually not a difficult or expensive thing to arrange although most people don't bother to do that.

Even though most solar panels operate on UV rather than visible light, any minor cloud cover drops the panel output quite noticeably. There is also the little detail that most solar panels only work in sunlight or with reduced output in very bright daylight. This means half the day does not contribute to electrical input and in winter, when the electrical need is greatest, the days are shortest, sunlight scarce and daylight quality very poor unless you live near the equator. The level of sunlight which you will receive drops off steadily the further you get from the equator as the light angle gets lower and lower. This also causes problems in winter with quite low obstacles casting a shadow on the panels and cutting the working time for the panel even further.

The effect of all this is that you will need a far greater claimed panel wattage than your needs seem to require and I would suggest that you probably need between two and three times as many panels as the stated panel wattage would suggest that you need. Considering that chapter 10 shows how to run a generator on water, it would be cheaper to buy and replace a generator on a regular basis than to buy batteries and panels and having to replace them. A generator also runs at night and through the winter.

However, if you are installing solar panels, please be aware that there are considerable differences between panels which have the same apparent rating. A key factor is the voltage produced by the cell under normal working conditions. This makes the difference between a good charging rate under poor conditions and a near-zero charging rate at those times. The good panels have a greater number of cells and the higher voltage produced can make a major difference, so check out the technical specification document on each panel you want to consider and pay attention to the voltage figures and not just the (maximum possible) "wattage" quoted by the manufacturer or sales person. The panels which I picked are made by Kyocera but do your own checking as designs change from year to year. At the present time, solar panels are only about 17% efficient which means that 83% of the power reaching them does not go to make electricity.

Solar panels change size during the day and so need to be mounted in such a way that allows for this expansion and contraction during the day and night. As you don't want to over-charge a battery, it is

generally considered essential to use a control circuit to prevent this happening. In real life, when you use the electricity generated on a daily basis, there is little or no chance of over-charging, but you can decide this for yourself.

One recent development is to use the solar panel(s) to drive a battery-pulsing charging system. This has the major advantage that battery charging does not stop when the light falling on the panel produces a voltage which is too low to charge the battery bank directly. With a pulsing unit, the charging pulse voltage is largely independent of the input voltage and so a good charging rate can be produced in poor lighting conditions, including twilight. This can extend the battery charging period very substantially, especially in winter when there is less light. At this time, one of John Bedini's companies is offering these units for sale.

Assessing solar panels generally from the standpoint of knowing what the snags are, unless you live in a very good location on the planet and have a good deal of spare money to spend, then they are not a great solution, but this is something which you also need to decide for yourself.

However, having said that, a scheme has recently been introduced in the UK and it appears to be a realistic option. Under this scheme, the householder does not buy the solar panels but merely pays to cover the cost of installing them. For example, this house:



has twenty-one panels mounted on the roof and the total cost to the home owner was just £500. The home owner receives a very much reduced electricity cost and expects to recover the installation cost within two years. Even in November at latitude 52 degrees North, these panels are performing well.

Not having to pay for the purchase of the panels themselves makes an enormous difference to the viability of such an installation. I understand that the strategy behind this scheme is to increase the presently tiny percentage of electricity which is produced from renewable sources, by offering people a scheme which actually makes it worthwhile to have an installation. No batteries are used in the installation.

While solar panels are generally large, cumbersome and expensive, there are some low-power applications where they could be used. There are literally millions of people around the world who have no access at all to electricity and e-mails which I have received indicate that what people miss most is the lack of electric lighting at night.

I have investigated the options to a fair degree, with the objective of providing a seriously good level off lighting every night for at least eight hours. Investigating the light source, I tested Compact Fluorescent Light bulbs driven by the Fuji-style Joule Thief or similar circuits. In my opinion, the light output which I managed to obtain was not adequate to be the only source of night lighting.

Checking out other light sources led to the 12V "G4" Light Emitting Diode arrays. These have an excellent lighting angle of 160 degrees and a very good light output of 160 lumens. A 100-watt filament light bulb has a light output of about 1600 lumens, and so, using a row of ten G4 LED arrays has the potential of putting out as much light as a 100-watt light bulb driven by the mains, which is 220 volts in most of the world.

In broad outline, there are various ways of providing an effective power source for such a very usable light source. One method is to use a battery which can power the light for up to eight hours to cover the period from nightfall to when most people go to sleep, and then use the remaining sixteen hours for an integral battery charger to charge the battery up again. This method does work and is under further development.

Another option is the larger, more expensive, but very simple method of using a solar panel to do the battery charging during the day, ready for use at night. Here is a suggested method for doing that:

Solar Panel Lighting

There are many alternatives to the components suggested here. One possible unit design looks like this:

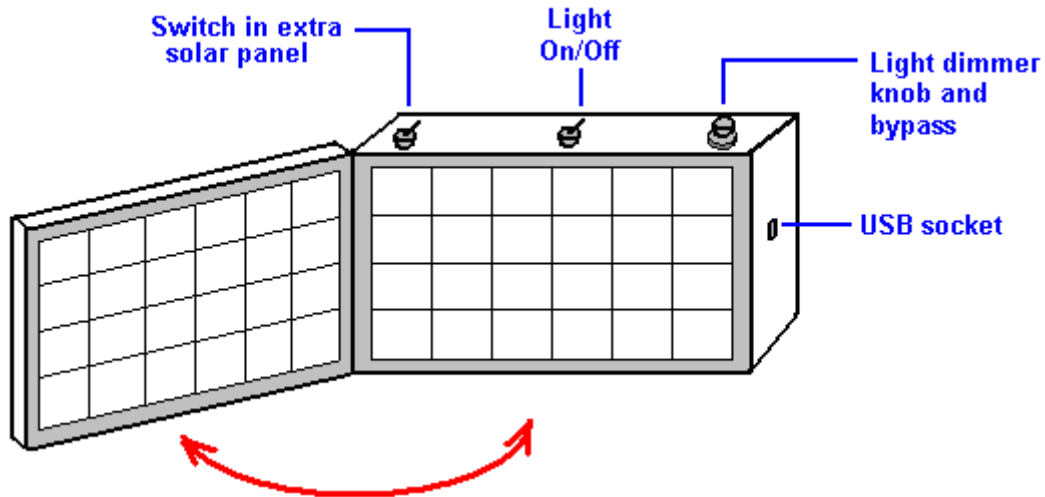

Any conveniently available solar panel of allegedly 10 watts could be used. These panels can supply a maximum of half an amp (or a little above) at 13 volts. It needs to be understood that it is unlikely that any solar panel will produce more than about 50% of its rated output, partly due to optimistic marketing and partly due to the fact that the sunlight (if any) is rarely exactly perpendicular to the panel at all times as the direction of the Sun moves one degree every four minutes.

One of the problems with such a unit is the selection of a suitable battery. Lithium batteries are excellent but the cost of a suitable lithium battery is ten times greater than the cost envisaged for the whole unit, effectively excluding lithium batteries. Lead-acid batteries are far too large, too heavy and too expensive for this application. Surprisingly, what appears to be the best choice is the very popular AA size rechargeable battery made with either Nickel-Cadmium or Nickel-Manganese, 50 mm long and 14 mm in diameter:

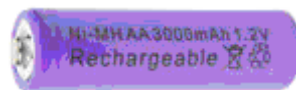

Rated at up to 3 Amp-Hour capacity, they can cost a little as 40 pence retail, including delivery. These are lightweight and can be placed in a battery box like this:



producing a 12-volt (nominal) battery pack. Using, say, five of these packs to give 12V 15 AHr capacity is a retail cost of about £25 whereas a lithium battery of that capacity costs well in excess of ten times that

amount, creating a wholly unrealistic price for the solar panel light, where size, weight and cost are critical factors.

For all that these solar panels are rated as being “10 watts”, the reality is that if it supplies half an amp into a 12V battery, then it is really, only a 6-watt rate of charge and that is in bright sunlight with the panel facing directly into the sun. As that almost never happens, we have to accept that we may only get on average 3 watts or so from the panel. One option is to use two panels, doubling the charging current for any given light level. As shown in the initial diagram, the second panel can be hinged alongside the main panel, avoiding any increase in the largest two dimensions of the unit. The panels are typically 337 x 205 x 18 mm in size, so an alternative option is to place them side by side to form a 410 x 337 x 18 mm unit which is then cased. While that is perfectly feasible, the size is a little large in my opinion. It needs to be borne in mind that these batteries are only 66% efficient, which means that for every 3 Amp-Hours fed into the battery, it will only return 2 Amp-Hours when supplying current after charging. As the lowest reasonable lighting level has been shown to be at a power draw of about 1.14 watts, if the panels provide a net battery power return of four watts, then the lighting period can be nearly four times as long as the charging time.

Extensive testing has taken place and with 12 volt lighting, the best lighting device has proved to be the G4 style 12 volt LED arrays as shown below. These arrays are very cheap, can be dimmed and come in two varieties, namely “white” and “warm-white”. Tests have shown that the white produces a very strong light and so, perhaps the warm-white variety may well be easier on the eyes as well as being closer to the human eye’s maximum sensitivity frequency of green. Measuring about 30 mm in diameter, each array costs less than one pound sterling and looks like this:



These LED arrays are mounted on the back of the box. A very useful optional extra would be to have a USB socket which can charge mobile phones or eBook readers. The additional cost is very low compared to the increased usefulness of the unit.



These views are what the user sees when looking at the outside of the socket. Socket type “A” is the most common on computers and related chargers. Pin 1 is the +5V power line and Pin 4 is the 0V or ‘Ground’ line. These sockets are readily available and are not expensive. Ideally we want an arrangement which draws no significant current when not in use and yet, which does not need a mechanical On/Off switch. For that we might use something like this:

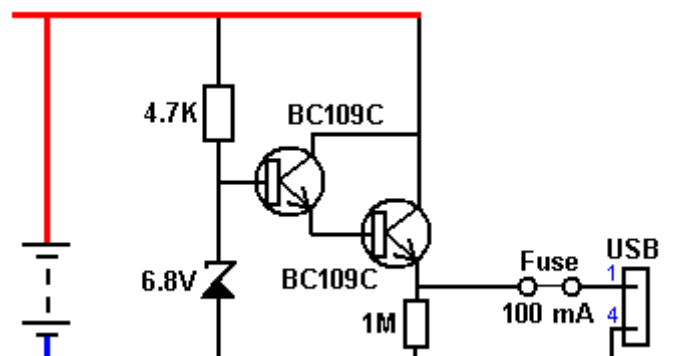

Here, the battery voltage of around 12V or whatever, is connected across a 4.7K resistor and a 6.8 volt zener diode. Two (cheap, and very widely available) BC109C transistors are connected as a Darlington pair in emitter-follower mode with a 1M resistor as their load. These transistors have a gain which typically exceeds 200, and so, two together like this, have a gain of 40,000, and so draw very little current from the zener diode current flow. As pins 1 and 4 of the USB socket are open-circuit, no current flows through the USB socket until such time as a load is connected and so, significant current flows only when a device is plugged into the socket and no On/Off switch is needed.

The main components of the Solar Panel Light can be put together very simply and it should be noted that this is a wholly safe system with only 13 volts or so being produced and so there is no possibility of any kind of electrical shock no matter what the user does. The physical layout might be something like this:

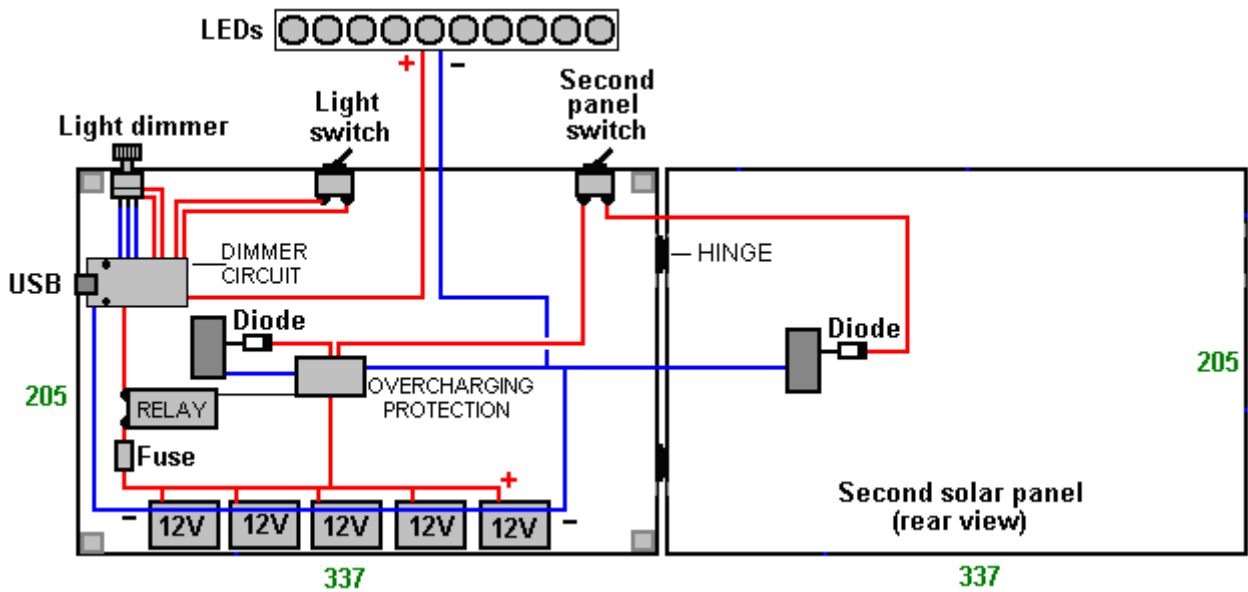

Although this view shows the back of the unit opened up, the LEDs are actually mounted on the outside of the back cover which is not shown in this view, and so, almost all of the internal space is available for the other components. Here, a simple diode connects the solar panel output to the five battery packs which are connected together in parallel to form a single battery. There is a simple battery over-charging circuit connected between the solar panel(s) and the batteries to handle the situation where the user leaves the unit charging in bright sunlight for several days and does not use the light at night. This is necessary because overcharging the batteries is harmful, reducing their useful life.

The battery current passes through a fuse in case that there is some highly unlikely and unexpected short-circuit through an abnormal failure of some electronic component. The optional USB socket is connected before the On/Off switch for the lighting. The final part is a simple dimmer arrangement for the LEDs. This is achieved using variable resistor with a graduated knob like this:



as this allows the user to immediately set the preferred lighting level for any activity. There can also be a switch which bypasses the dimming mechanism, applying the full battery voltage to the LEDs. This option has two applications in that it allows a fully charged battery to put out a full 1600 lumens of lighting if the user wants this. It also provides the option for when the battery is almost fully discharged, of bypassing the dimmer transistor which drops 1.4 volts, and so, supply the very last of the battery charge to the LEDs. A practical, working circuit might be like this:

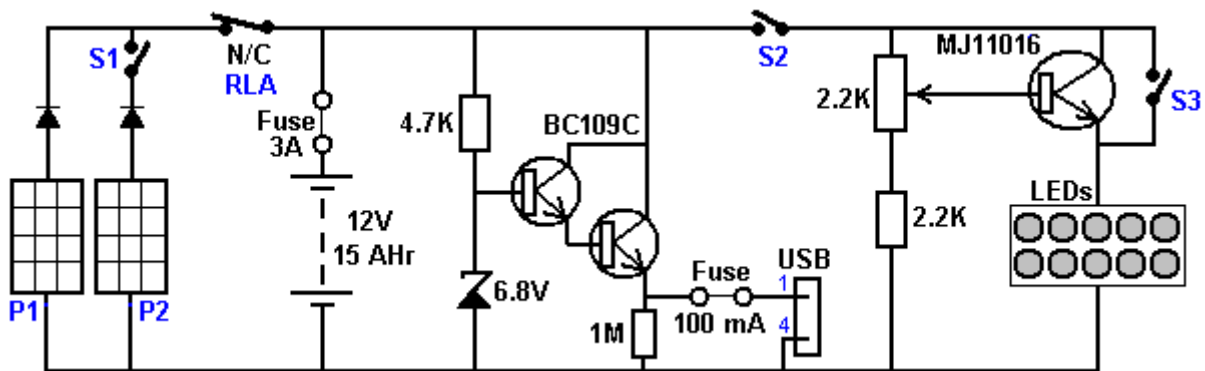

With this arrangement, solar panel P1 is wired in all of the time and if the fuse is intact, will charge the battery if the ambient light level is reasonable. If switch S1 is closed, then solar panel P2 doubles the solar charging capacity without increasing the overall main case dimensions. When closed over, the face of panel P1 faces that of P2, protecting both when the unit is being carried.

The two BC109 transistors provide the USB socket output which is connected all the time, allowing USB charging up to 100 milliamps which is the limit for the transistors. The 4.7K resistor provides a small current flow through the 6.8 volt zener diode, providing a fixed voltage for the two BC109 transistors, which draw very little current from it. USB devices vary enormously in the current which they need, and so this arrangement is provided. If higher USB power is needed, then using 2N2222A transistors would allow up to 800 milliamps of current, although this is not the objective of the design.

The switch S2 is the On/Off switch for the light. The light level can be adjusted down to zero, allowing the unit to be used as a night-light for a child's bedroom if that is desired (or a low light level is wanted for a 'romantic' meal). If switch S3 is closed, the light dimmer is bypassed, applying the battery directly to the LEDs, giving 1600 lumens, which is the equivalent of a 100 watt incandescent bulb powered by the mains. That level of lighting needs a 1.3A very high level of current from the battery, and so it probably should not be used for more than a few minutes if lighting is needed for eight hours.

Lowering the light level is a very sensible thing to do, for two reasons. Firstly, the human eye is very bad at assessing when a bulb is fully lit, and so a much lower current draw still gives a light level which is not seen as being much different by the user, and that gives a major boost to the length of time during which the battery can power the light. Secondly, the light output from the LEDs is highly non-linear with most of the light output being produced at low current levels. Given the full current, the light output is spectacular, and quite possibly more than the user would prefer, and so, the user should choose a lower lighting level controlled by the dimmer knob.

The lighting level may be varied in accordance with what the user is doing, with perhaps, a higher level when having a family meal, and a lower level when relaxing afterwards. Having ten LED arrays gives a high lit surface area at all lighting levels, which is an advantage as well as allowing good lighting at a lower current draw. However, additional switches can be provided on a prototype so that during testing, different numbers of LEDs can be selected to give an indication of whether or not, making a unit with fewer LED arrays would be a good idea.

The diode between the solar panel and the battery, is there to stop the panel drawing current from the batteries when the panel is in darkness, and that diode needs to be able to carry 0.6 amps at 20 volts, and so any ordinary diode such as the very cheap 1N4007 1000-volt 1-amp diode can be used.

A battery over-charging controller is desirable, to prevent the battery voltage from exceeding the fully charged voltage of the batteries as overcharging a battery reduces the length of its working life. With normal use, that will not be needed, but it should be included to deal with highly abnormal conditions. Ideally, you want this protection circuit to drop no voltage at all and draw no current at all. To achieve those very stringent requirements, a relay is used. The relay is not normally powered and so does not draw any current. The current flowing from the solar panel flows through the 'Normally Closed' ("NC") relay contact, dropping no voltage at all in the process. A circuit for this might be:

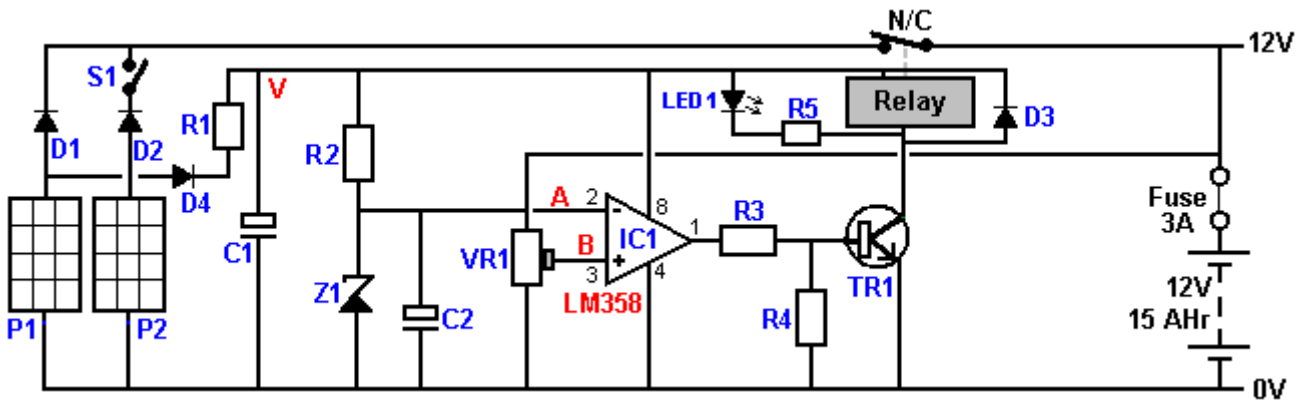

In this circuit, the voltage produced by the solar panel is passed through the closed relay contacts and the fuse, to the battery, charging it. Resistor R1 allows a current to pass through it and into capacitor C1, building up a voltage at point "V" and powering the overcharge-prevention circuit. Resistor R1 can be omitted. An LM358 operational amplifier is suggested for IC1 as it uses almost no current and has a very wide range of working voltage. Here, it is wired as a comparator and so it compares the voltage at point "A" with the voltage at point "B". The voltage at point "B" can be set by adjusting the preset variable resistor VR1. The voltage at point "A" is set by the Z1 zener diode voltage fed through its resistor R2. As long as the voltage at point "B" is lower than that at point "A", the transistor will be off and the relay will not be powered up. As the battery voltage rises and passes the 13.5V voltage (or whatever voltage is considered the highest allowable for the battery being used), the voltage at point "B" rises above the voltage at point "A" and the output of the LM358 comparator swings suddenly and rapidly upwards, powering the transistor through resistor R3 and switching the relay on, disconnecting the solar panel from the battery. The solar panel continues to power this circuit until the ambient light level drops to the point where the panel voltage is low enough to drop the relay out again, and at that voltage level, the batteries will not get overcharged. An LED with its current-limiting resistor can be wired across the relay and that LED will switch on when the relay is triggered, indicating to the user that the battery is fully charged. If there is no output from the solar panel as is the case at night or when the case is closed, then there is no voltage for operating the relay and the overcharging circuit is inactive which is what is needed in that situation.

The light output from the LED arrays is highly non-linear and so at a total of just 1.14 watts the ten LED arrays put out a considerable level of lighting. The voltage across the LEDs at that light output is 9.5 volts and the battery packs can reach 13.8 volts when fully charged. To control the current draw, voltage and output lighting level, a circuit such as this can be used:

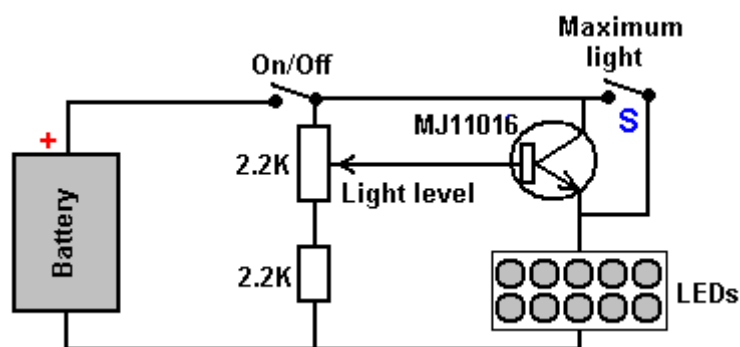

The variable resistor cannot carry much current and so a very powerful, high-gain transistor controls the current flowing through the LED arrays. There is a voltage drop of about 1.4 volts across the transistor, and that prevents too high a voltage being applied to the LED arrays if the battery voltage is particularly high. The lowest voltage across the LEDs which gives usable lighting is 9.5 volts. When the battery voltage drops below 10.9 volts (indicating a heavily discharged battery), then the lighting period can be extended by closing switch S, short-circuiting the dimming circuit and giving an extra 1.4 volts to the LEDs for a short period, as

the batteries, being almost discharged, will run down rapidly. With this simple lighting control, the user can decide what lighting level should be used at any given moment.

Constructing a unit of this type requires very little expertise, very little electronics constructional ability, no construction of components and being entirely of conventional, fully-accepted existing designs there is no opposition whatsoever to these units being constructed and sold. The back of the case looks like this:

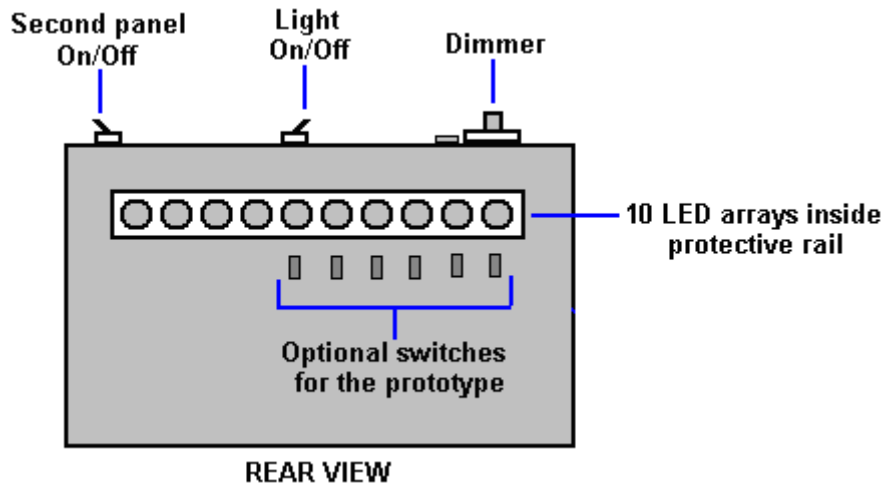

For evaluation purposes only, six extra switches can be added in order that the person testing the unit under actual working conditions can select 5, 6, 7, 8, 9, or 10 LED arrays to assess the effect of these different configurations.

The suggested overall circuit for the Solar Panel Light is therefore:

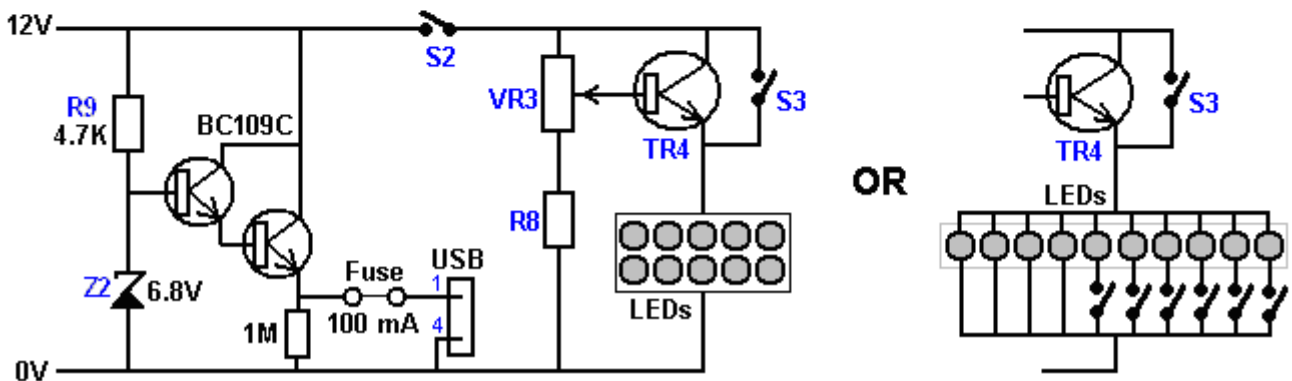
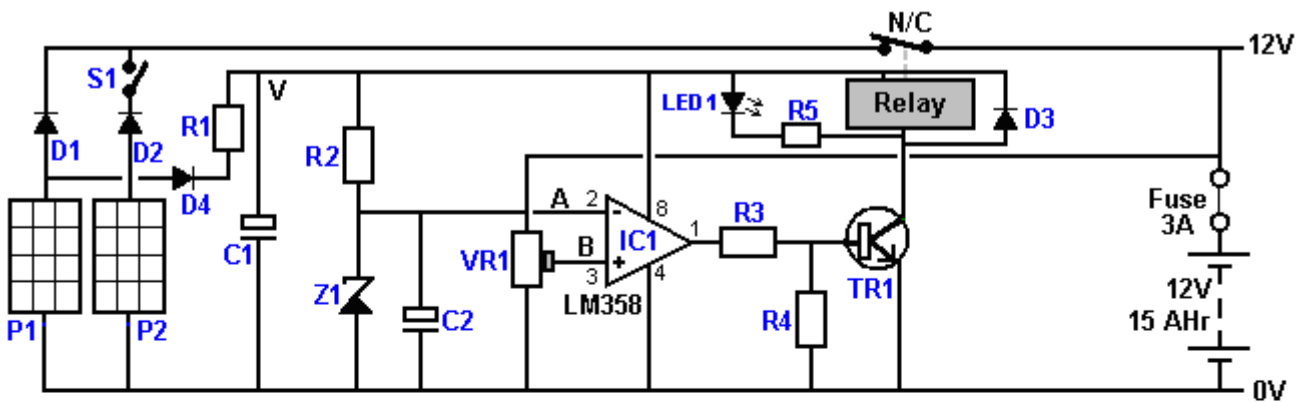

Components

D1 – D4 1N4007 1000V 1A (lowest cost)
 R1 – 100 ohm 1 watt carbon 10%
 R2 – 2.2K half watt carbon 10%
 R3* – 12K half watt carbon 10%
 R4* – 1K half watt carbon 10%
 R5 – 470 ohm half watt carbon 10%
 R6 – 1M half watt carbon 10%
 R7 – 100 ohm 1 watt carbon 10%
 R8 – 2.2K half watt carbon
 R9 – 4.7K half watt carbon
 VR1 – 47K preset
 VR3 – 2.2K with knob
 C1 – 1000 microfarad 25V
 C2 – 100 microfarad 25V
 Batteries – 50 AA size NiMh
 USB socket type “A”

TR1 – 2N2222A
 TR2 – BC109
 TR3 – BC109
 TR4 – MJ11016 or (BC109 + TIP3055)
 IC1 – LM358
 LED1 – any LED 3 mm to 10 mm
 LEDs 2-11 – 12V G4 160 lumen arrays
 S1,S2 (S4 – S9) – SPST rocker 3A, 12V or more
 S3 – 1A SPST integral with VR3
 Z1 – 5.6V 1.3 watt zener diode
 Z2 – 6.8V 1.3 watt zener diode
 Solar panel – 10 watt nominal
 Fuse – 20 mm glass 3A with holder
 Relay – 12V, 400 ohm SPST 3A
 Battery boxes – five 10 x AA (12V) type

* These resistor values are approximate and may need to be adjusted depending on the actual transistor being used in the build. Most component values are not in any way critical.

There are many alternative suppliers and local supplies should be checked out. Google can usually list local suppliers and their pricing can be checked out to see if it is competitive. It is usually possible to place orders through eBay and frequently, the lowest costs for small quantities can be had from China although there may be a delay of a month before the purchased goods actually arrive.

Here are some possible component connection details:

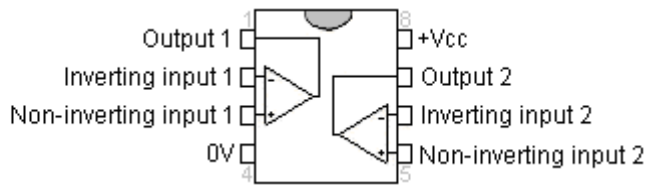

As the very versatile LM358 chip has two operational amplifiers inside it, we may as well use the second one as a buffer as that requires no additional components:

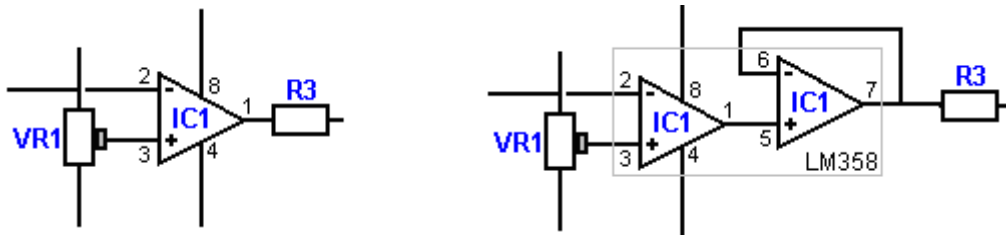

This makes the overall battery protection section:

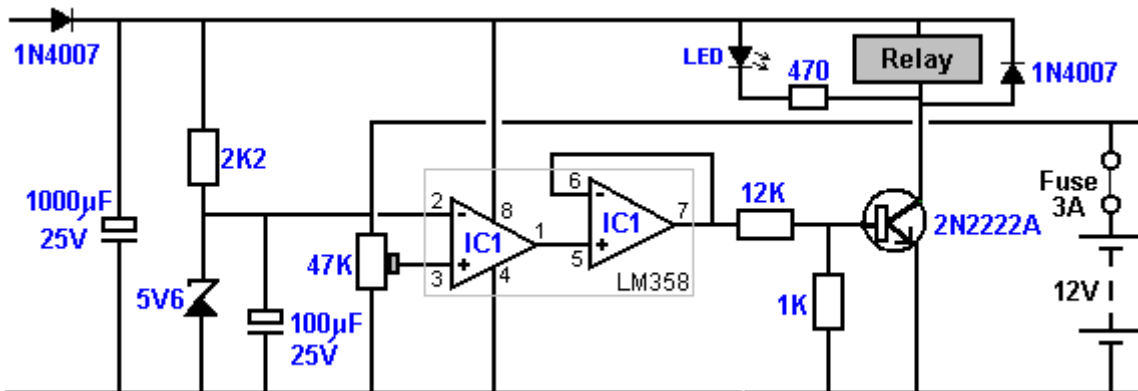

And a stripboard layout might be:

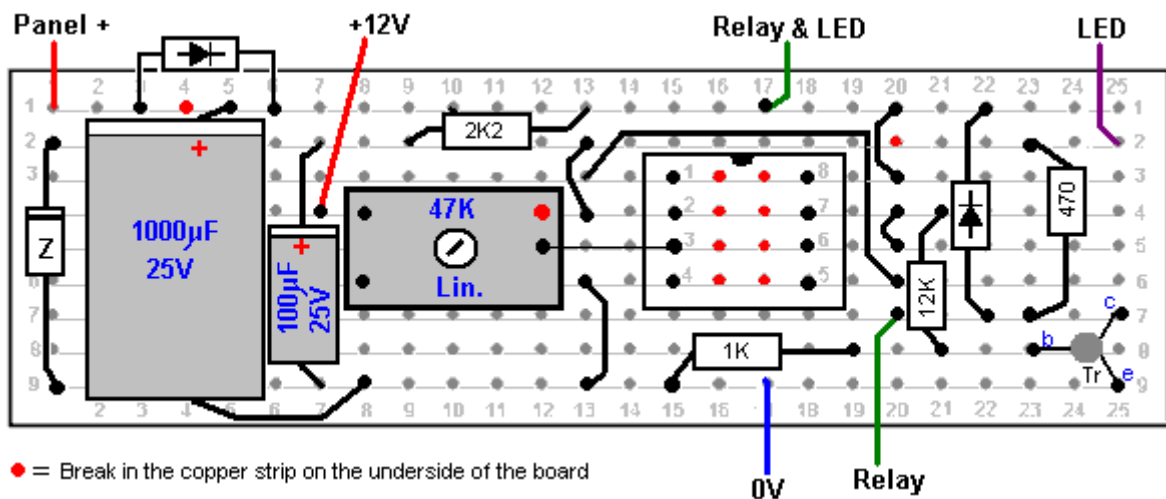

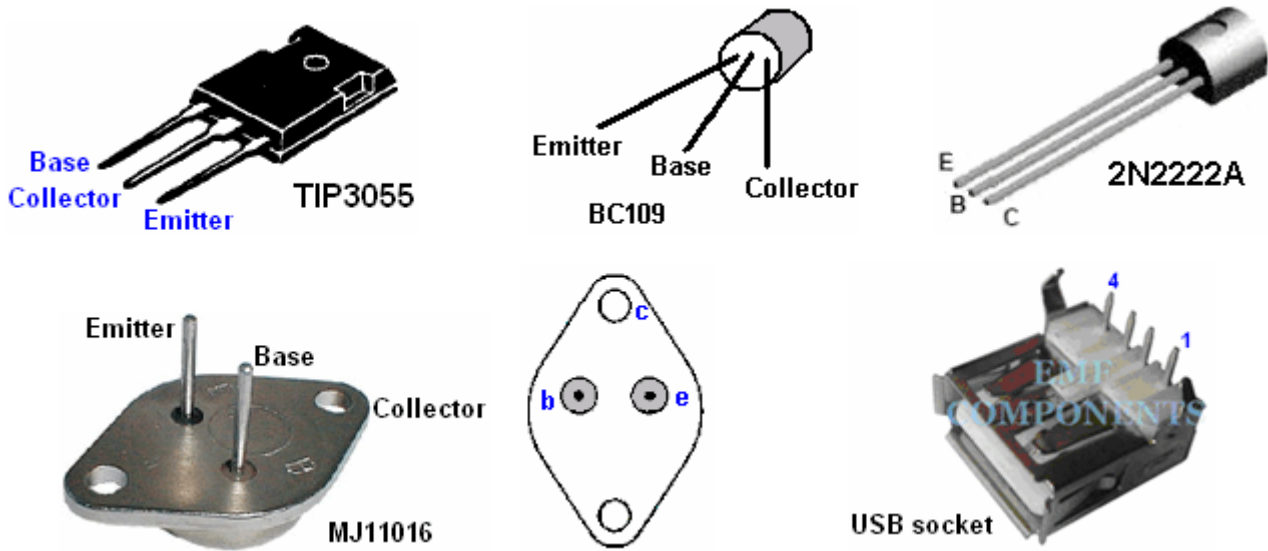

As the TIP3055 transistor is much cheaper than the MJ11016 transistor (not to mention easier to get and easier to connect to) and the BC109C is very cheap, we will use that combination on a standard size of stripboard:

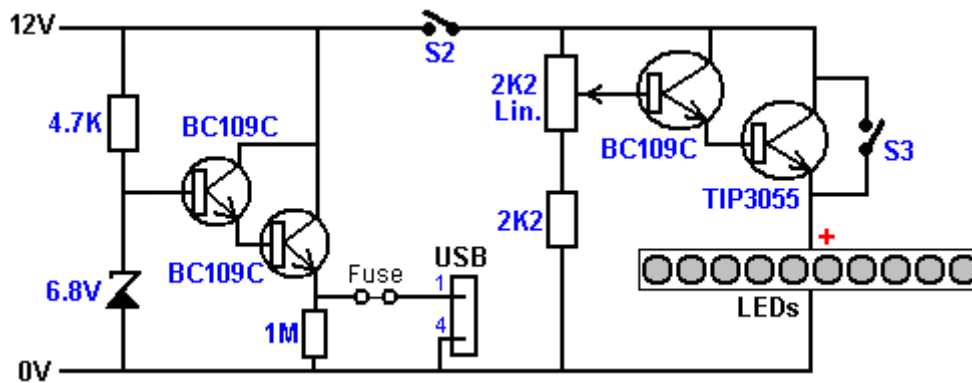

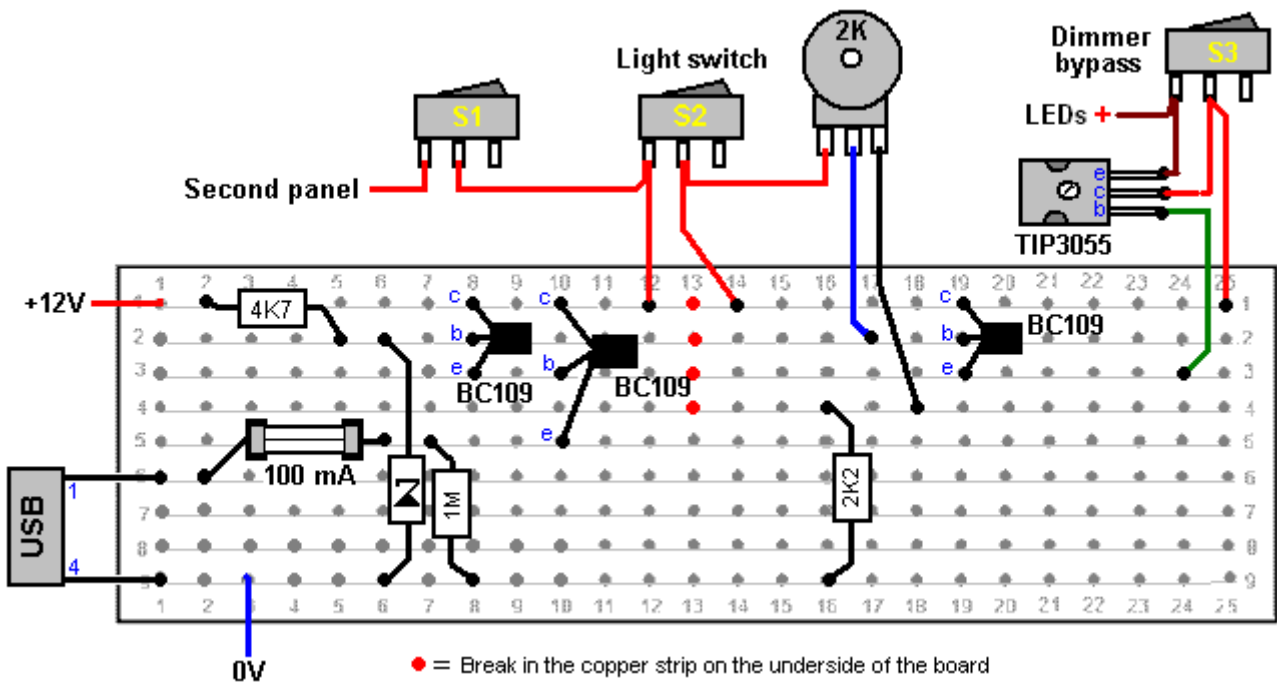

A prototype has now been built and one change made is the use of a separate fuse on each of the 12V battery packs, to ensure that should an individual 1.2V AA battery become defective and act as a short-circuit, then the fuse will blow due to the high current inflow from the other battery packs in the battery bank, and the unit will continue to function normally without any kind of human intervention.

In passing, tests have shown that this unit works very well indeed in complete darkness outdoors when carried as a lantern, giving excellent, broad-beam lighting when walking along unfamiliar roads and lanes.

Solar panels rated at 10 watts come in different shapes and sizes. The one spoken of here looks like this:

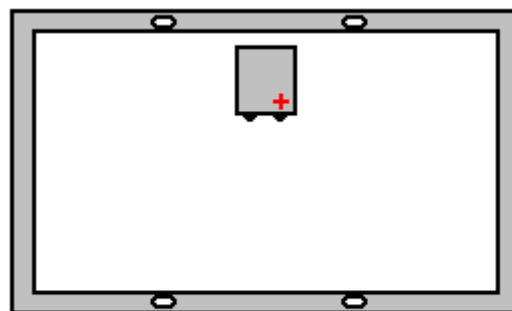

REAR VIEW

As a laminate flooring plank 7 mm thick, was to hand, it was used as the initial constructional material, along with a length of 10 mm square timber batten. The method used was:

Construction sequence:

1. Cut two strips 120 mm wide (not counting the rebate) the full length of the panel.
2. Cut two strips the width of the panel less two plank thicknesses.
3. Attach the USB socket about 50 mm from the end of one short plank strip (cut out: 5 mm x 13 mm approx.) and epoxy it securely in place.
4. Attach three switches (cut out 13 x 19 mm) and the variable resistor near the LED-side of one long plank strip (leave 15 mm. clear between the switch holes and the edge and 25 mm for the variable resistor hole).
5. Cut two battens the full length of the panel less two plank thicknesses and attach them centrally to the bottom edge of the strips, using Impact Evostick:

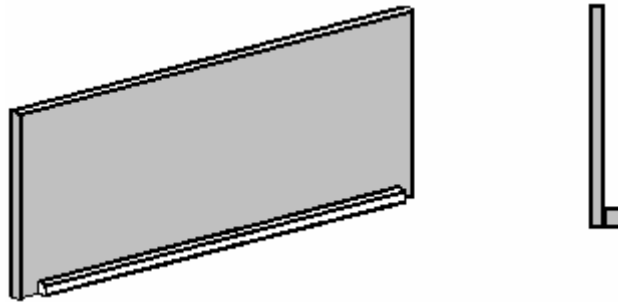

There must be at least 7 mm clear at each end of both battens.

6. Align the long sides with the long edges of the panel and measure the gap between the battens:

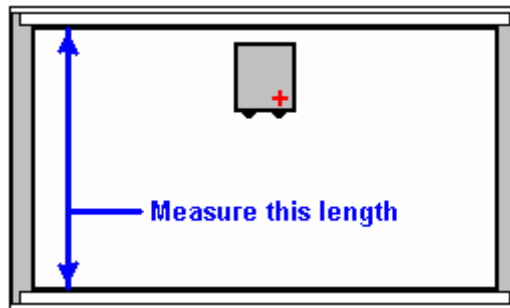

And using about 3 mm less than that length, cut two battens and attach them to the centres of the bottom edges of the two side pieces.

7. Using Impact Evostick, stick one long and one short plank strip to each other and in an L-shape to the panel edge. Do not apply Evostick to the underside of the long batten where it passes over the slots cut into the aluminium frame – leave about 6 mm clear on each side as epoxy can be used through the slot, to attach the batten even more firmly to the frame of the solar panel. Note that the short strip stops off seven millimetres short of the edge of the solar panel frame in order to leave room for the second long step to butt up against it and still align exactly with the edge of the frame:

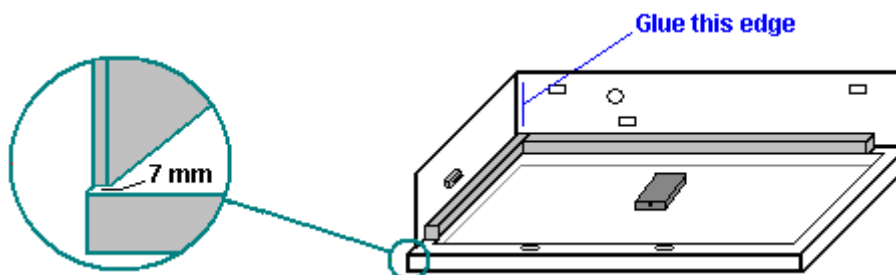

8. Using Impact Evostick, stick the other short plank strip to form a U-shape:

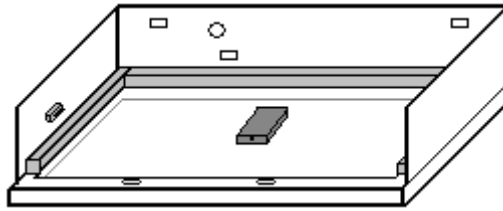

9. Using Impact Evostick, stick the remaining (switch-mounting) long plank strip with its batten in place, to complete the box frame. Each end of the short (vertical) strips forming the sides of this box, are glued to the inside face of the long strips:

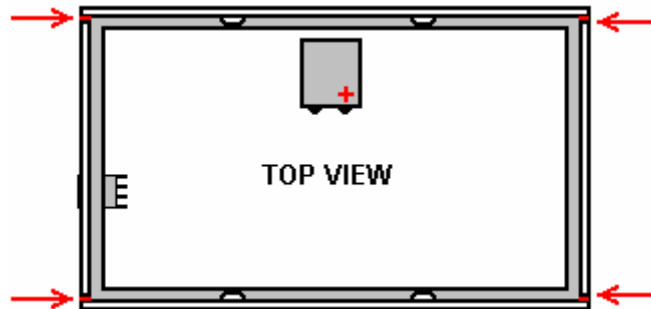

10. With the box upside down, use epoxy to attach the frame through the slots to the timber strips.

11. Cut and stick corner strips to reinforce the box and provide screw-receiving posts at each corner:

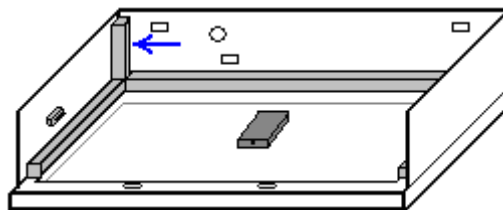

12. Position the battery holders and construct a battery-holding frame to allow secure batteries during use and yet the ability to replace the batteries, should that become necessary. If the box is enclosed at the back, then the rear cover can 'close' the box when screwed in place. If spacers are placed between the battery boxes, that allows air circulation if the batteries warm up when being charged or discharged (probably the latter if maximum light output is selected). The battery holders can be soldered to directly instead of using clips, and if that is done, then sufficient wire needs to be left so that the battery holders can be angled apart to allow easy access to the batteries.

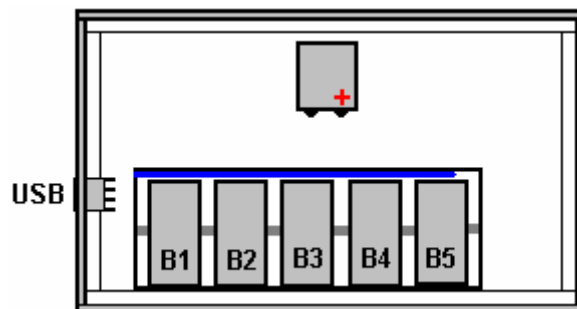

13. Construct the USB and light-dimmer circuit board and mount it near the USB socket and dimmer control:

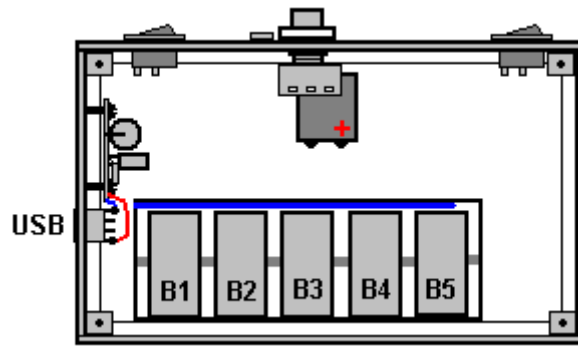

14. Mount the relay and the fuse-holder and wire the battery through them:

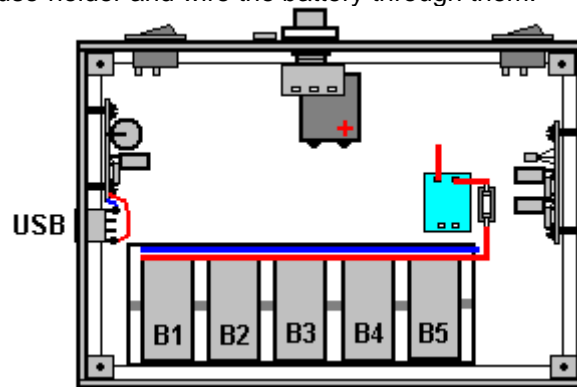

15. Cut the back of the case accurately so that it fits exactly into the case, resting on the four corner posts and being flush with the sides. Bend the LED legs and pass them through small diameter holes drilled to take them, and glue the LED arrays to the outside of the back panel, surrounding them with a protective rail and mounting the optional switches underneath (if required). It may be easier to mount two rows of five LED arrays and have five extra switches.

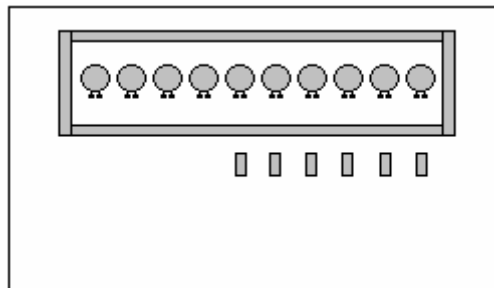

16. Complete the inter-component wiring and carry the two lighting wires across to the back panel, leaving enough slack to make it easy to lay the panel down while working on it and connect up the LED arrays and switches. Also, print out a copy of the circuit diagram and paste it inside the back panel because it is unlikely that you will remember exactly what circuit and circuit components were used if you open it up years later:

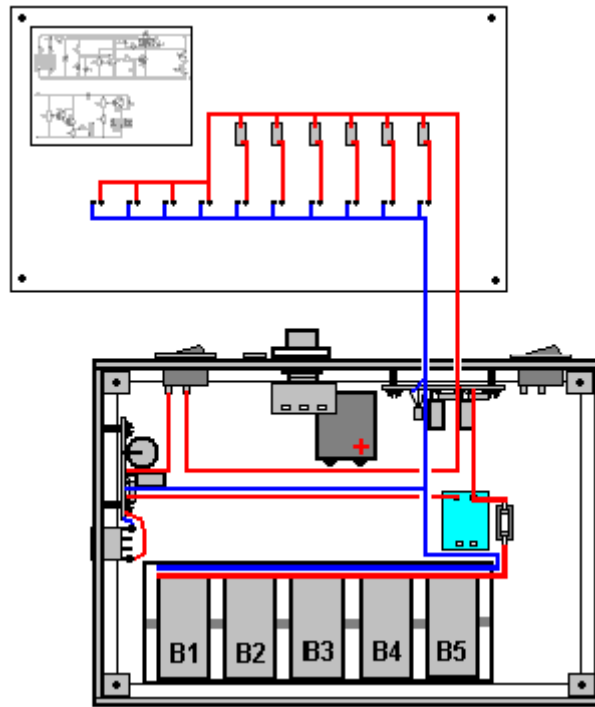

17. Confirm that the circuit functions correctly and then attach the back panel using countersunk screws or bolts. Attach a back cover to the second solar panel and connect the two units with hinges:

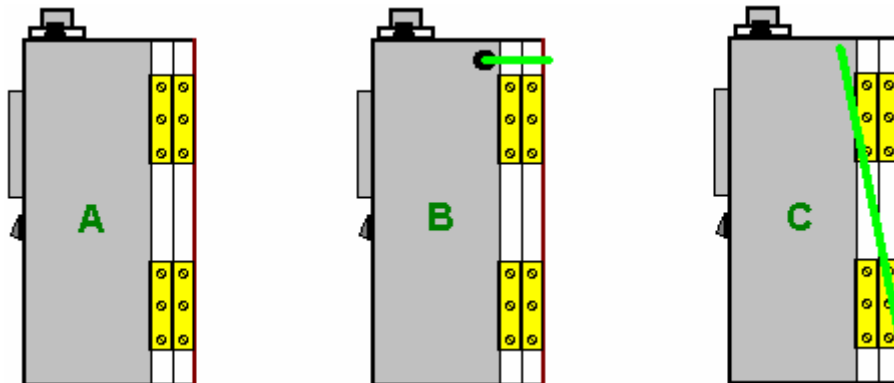

This leaves the problem of how to run the wire from the second solar panel through to the main circuit area considering that the second panel moves relative to the first panel. There are two obvious options. The first is shown in arrangement "B" where the wire from the second panel slides through an over-sized hole when the panels are opened out. That is relatively neat but it leaves the circuitry area open to weather and/or insects as the unit is liable to be left outside to charge in the sun (and possible rain).

The second option is shown at "C" where the connecting wire is sealed where it passes through a panel. Ideally, there should be no flexing of the wire when the second panel is opened out. So, to minimise any flexing, the wire with the sealed ends is given as long a path as possible, so that there is very little change in the distance between the sealed ends and so, minimum flexing will occur. Countersunk bolts are used on the hinges so that the panels can open fully. When open-circuit, these panels generate more than 21 volts in mild sunshine.

18. When fully assembled, the balance point can be determined and a carrying handle attached immediately above the balance point:

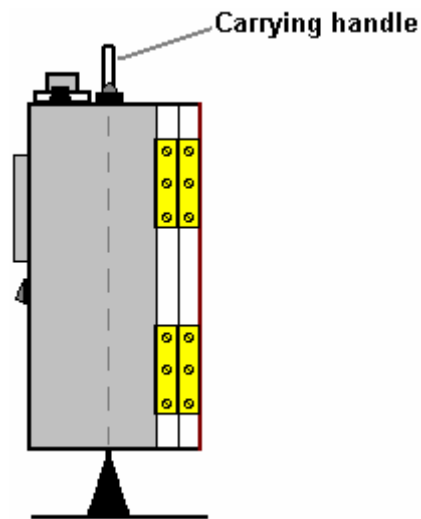

This is what the prototype looks like:

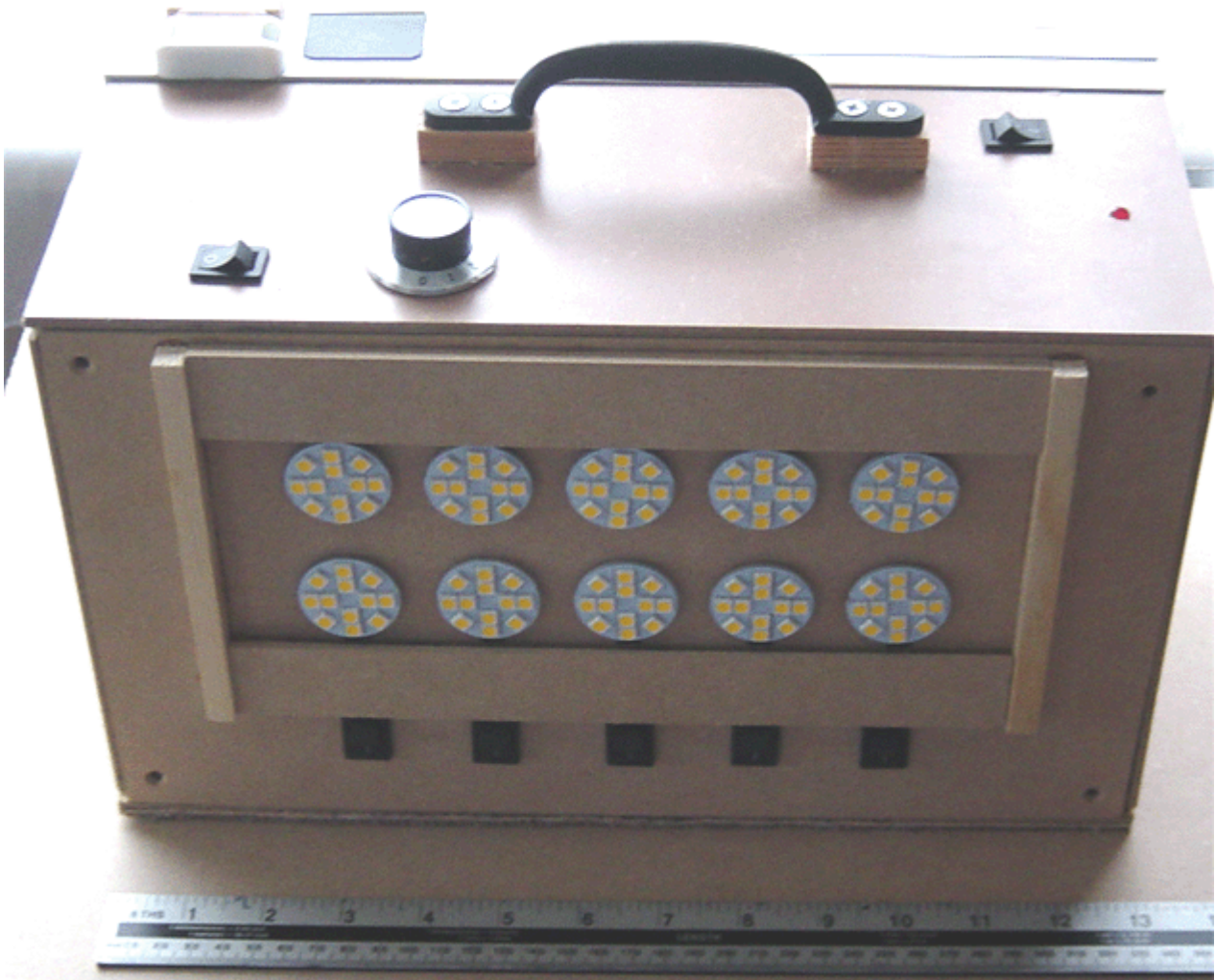

The strips to the right and left of the LED arrays are to protect the LEDs if the unit is placed LED-side down on a hard surface. They are spaced far enough out so as not to obstruct the light which has a 160-degree arc of illumination. The strips also facilitate the removal of the back as it is a deliberately tight fit on the assumption that the unit will occasionally end up in rain. For convenience of construction, the 'legs' of the LED arrays have not been bent but wires soldered to them pass through small holes drilled in the panel. The

LEDs are glued to the panel using a scrap of stripboard as a spacer as here are manufacturer solder joints on the back of the LED arrays. The LED wiring joints and wires are covered by a strip of 3 mm MDF (Medium Density Fibreboard) raised 3 mm above the panel by a narrow strip of 3 mm MDF underneath. For convenience, just five optional switches have been provided, and interestingly, the lighting level with just five LED arrays is substantial. When opened out, the unit looks like this:

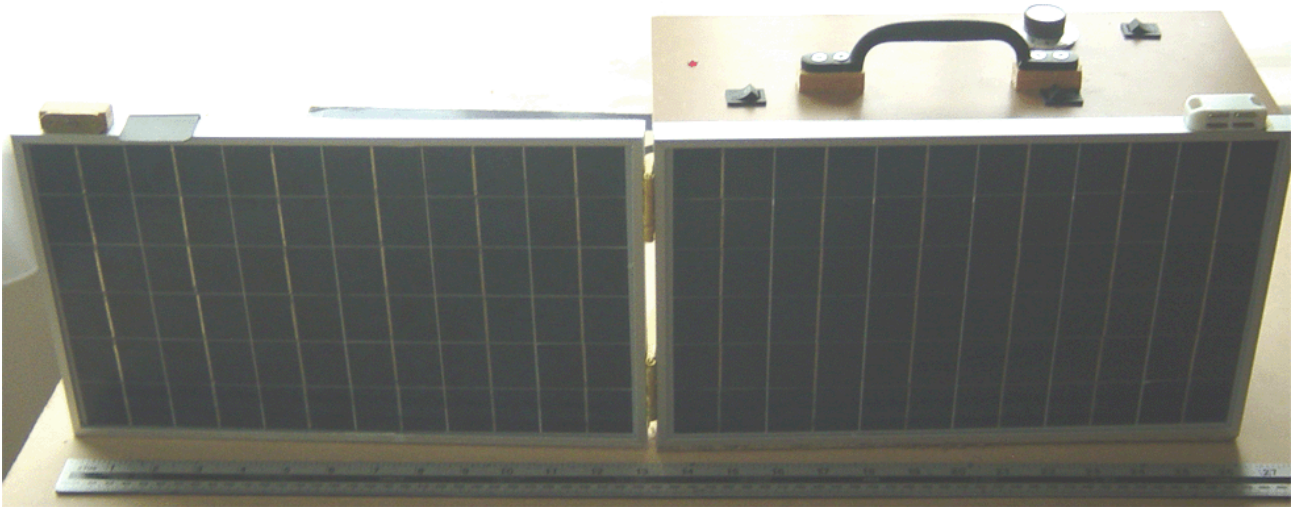

A piece of 9 mm x 9 mm timber fits neatly inside the aluminium frame of the solar panels, allowing the hinges to be screwed securely to both frames. The unit is a good deal heavier than I would have liked, but it is a very versatile piece of equipment which might well find a use in the parts of the world where it is generally sunny during most days and where there is no electric light available at night. Here is a tester checking the light output during daylight:



A Simplified Version

Tests have shown that the light output from a single G4 12V LED arrays driven fully is substantial when in a totally dark environment. This fact leads to the suggestion for the following design. For versatile lighting without the need for any electronics, the following is possible:

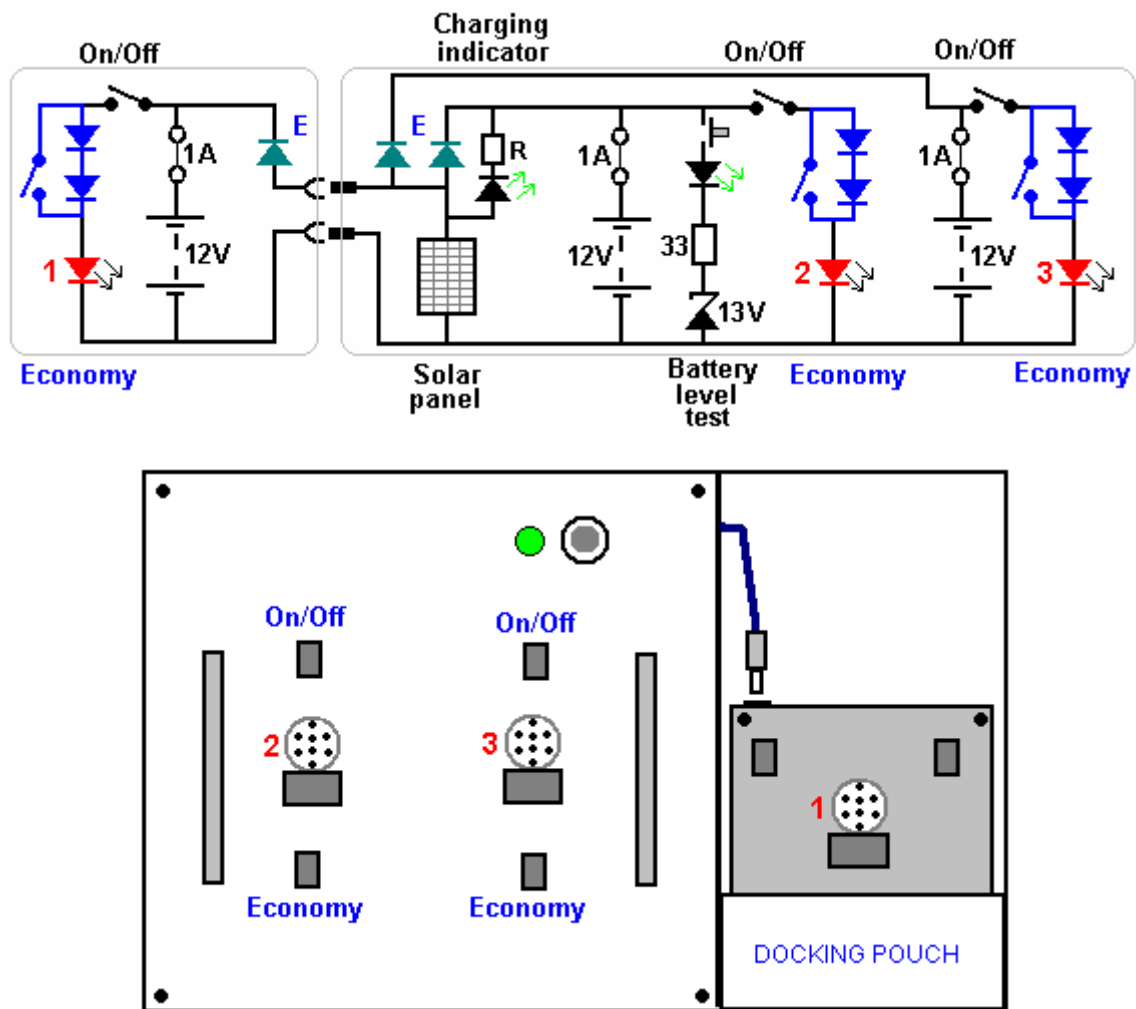

This version has only one 10-watt solar panel, three LED arrays and three battery packs. There are three self-contained sections, one of which is mobile to allow lighting from two different directions (or even in two separate rooms). Each LED array has an "Economy Mode" switch as well as its own On/Off switch. While that sounds like no big deal, it does add considerable versatility.

1. The user can have just one LED switched on and when its battery starts to drop in voltage, the Economy Mode switch can be closed to boost the light level, and a second LED can be switched in to give a major lighting boost. Similarly, the user can do that again when the second battery is getting low, switching in all three LEDs. This would give an exceptional length of lighting time with considerable light output at all times.
2. The user can opt for maximum lighting having all three LEDs on, illuminating from either one or two directions.
3. The user can opt for two LEDs initially, lighting from two separate directions and when battery voltage starts to drop, switch in the third LED.

Considering the simplicity of the construction (with no electronics involved) that is a considerable level of versatility. The "Economy Mode" is just a switch with two diodes such as the 1N4007, wired in series across the switch. These diodes cause a 1.4-volt voltage drop if the switch is not short-circuiting them. While that wastes power the waste is nothing remotely like the reduction in current draw caused by the highly non-linear characteristics of the LED array, as it drops the 134 milliamp current draw of the prototype down to just 95 milliamps, which is a reduction of about 30% for only a very minor reduction in perceived light output.

The mobile section gets its charging power through a standard DC 2.1 mm plug and socket. It would be possible to charge it from a car "12V" socket (which is actually about 14V with the engine running and typically 12.8V with the engine off), **IF** and only if, a current-limiting arrangement is introduced in the connecting lead, as a car battery can supply many amps of current and a NiMh AA battery should only be

charged with a relatively low current. I would suggest that the charging current for a 3000 milliamp NiMH battery should be kept down to say, 100 milliamps, probably with a suitable resistor.

However, this arrangement leads on to a completely separate system such as this:

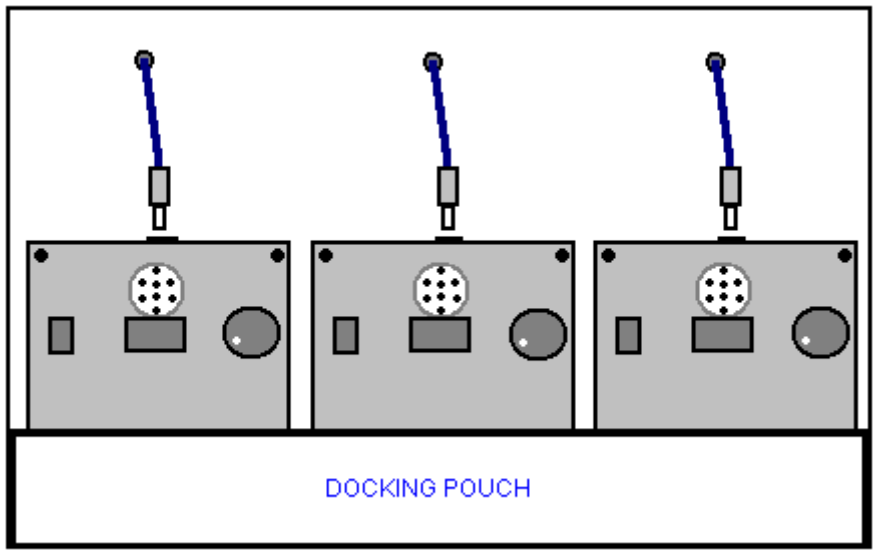

Here, three identical units are charged from the solar panel, which can be any size or wattage, although a ten-watt panel would be considered to be the minimum for daily use. Each unit is in effect, just a wide-beam, high-intensity, high-capacity solar torch which can be dimmed and which will stand securely when unsupported. It has the advantage that the units can be constructed one at a time, and if necessary due to time constraints, or perhaps, very poor daylight, just two or even one unit can be charged from the entire solar panel output. If manufactured and sold, then the units could be sold separately, allowing a lighting system to be extended and improved when additional funds become available (or when the user has tried one unit and discovered how effective it is). Each unit is easy to understand and use:

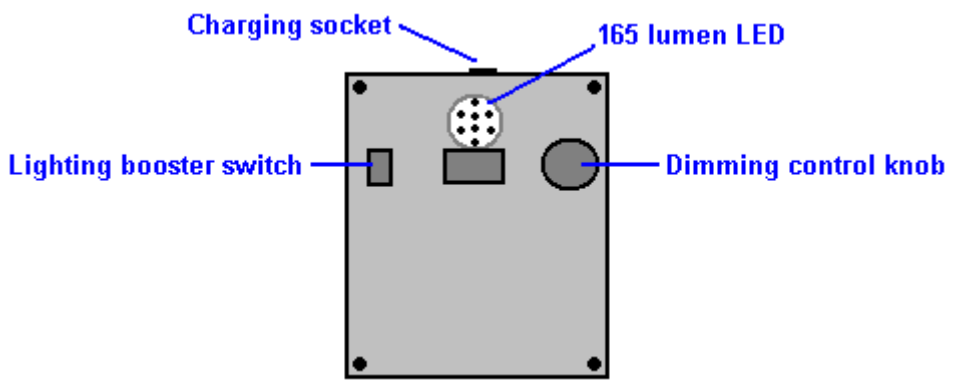

The light dimming control knob is also the On/Off switch, so just turning it clockwise turns the unit on and increases the light to the desired level. If the light-boosting switch is On, then maximum lighting is produced as soon as the dimming knob is turned clockwise, as that operates the On/Off switch. If the light is being used at a dimmed level and the light level drops due to the battery running low, then the booster switch allows the maximum light to be produced by applying whatever charge remains in the battery direct to the lighting LED.

The concept is very simple and straightforward, and surprisingly, the construction is also very simple. The solar panel just needs a backing plate attached and a docking pouch attached. The panel's electrical connections are just carried out through three wires which have standard DC connector plugs attached to them. When constructing the pouch, just remember to allow for the thickness of any protective material used to line the inside of the pouch to protect the units and hold them securely in place when charging. A suitable working circuit could be:

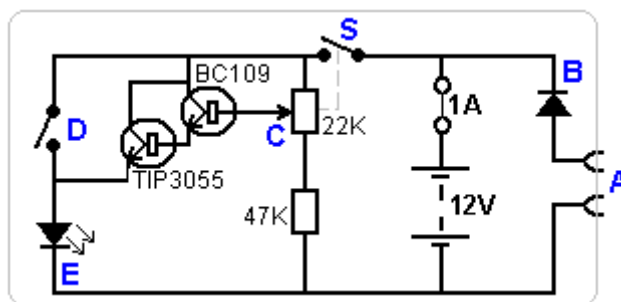

In this circuit, the solar panel connection socket “A” feeds power to the battery through diode “B” which prevents there being any problem if the user short-circuits the output socket as well as preventing the panel drawing current from the battery when it is dark.

When the On/Off switch “S” is closed by turning the dimmer knob clockwise, the battery voltage is fed to the remainder of the circuit. The 22K variable resistor “C” has about the top one third of the battery voltage across it as the 47K resistor has roughly twice as much resistance and so will have about twice as much voltage across it. This means that if the battery is charged to 12-volts, then the slider of the variable resistor “C” will have a voltage range of 8-volts to 12-volts and as the transistors drop about 1.4 volts, the lighting LED “E” will receive 10.6V to 6.6V depending on the setting of the variable resistor (provided that the booster switch “D” is open). The main working light output from the lighting LED ranges from a very bright 12V down to a reasonable lighting level at 9.5V, and so the variable resistor adjustment can take the light output down to near zero. Closing switch “D” immediately gives the maximum possible lighting for any state of charge of the battery.

The current flowing through the 22K and 47K resistors will be lowest when the battery has dropped considerably. Let us check the design if the battery voltage has dropped to 10V which is a serious level of battery discharge. The current flow through variable resistor “C” will be $10V / 69K = 0.145$ milliamps (a negligible current draw as far as the battery is concerned). The question then is, will there be enough current to supply the transistors and drive the lighting LED? Well, if the TIP3055 transistor has a gain of only 20, and the BC109 transistor feeding it has a gain of just 200, and the LED is drawing 95 milliamps, then the base current for the BC109 would be $95 / 20 / 200 = 0.024$ milliamps which is less than one fifth of the current through the variable resistor. In reality, the transistor gains are likely to be higher and a combined gain of nearly double the above amount of 4000 is probable. The build can be in a plastic project box 160 x 95 x 55 mm:

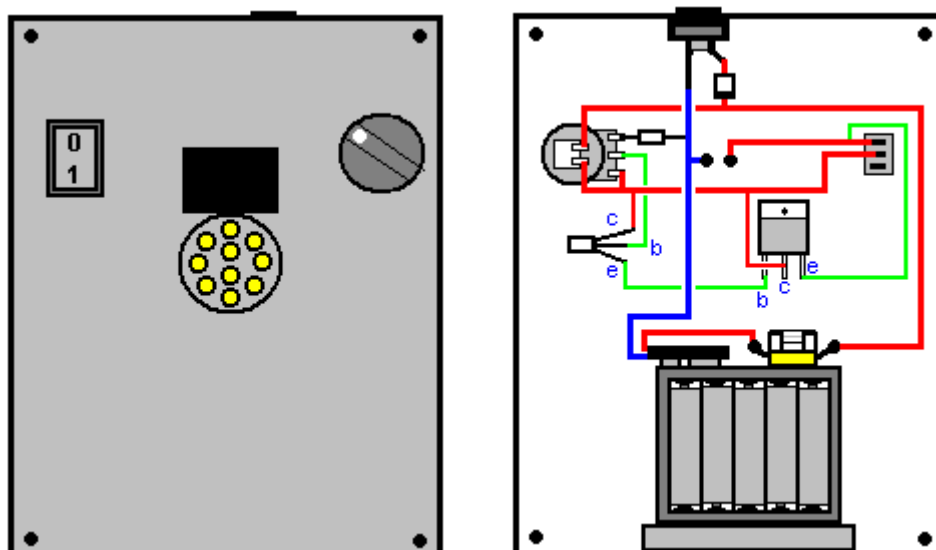

As can be seen here, the wiring is fairly straightforward, although care must be taken when connecting the positive wire from the solar panel. The positive wire is normally passed through the central contact of the DC connecting plug and socket, but in this instance it is not taken direct to the fuse at the positive terminal of the battery. Doing that would be an instinctive thing, but in this case, there is a diode between the socket and the battery positive / fuse combination in order to prevent current flow from the battery outwards through the

socket. This is a very simple and useful project even though it is a renewable energy project and not a free-energy project.

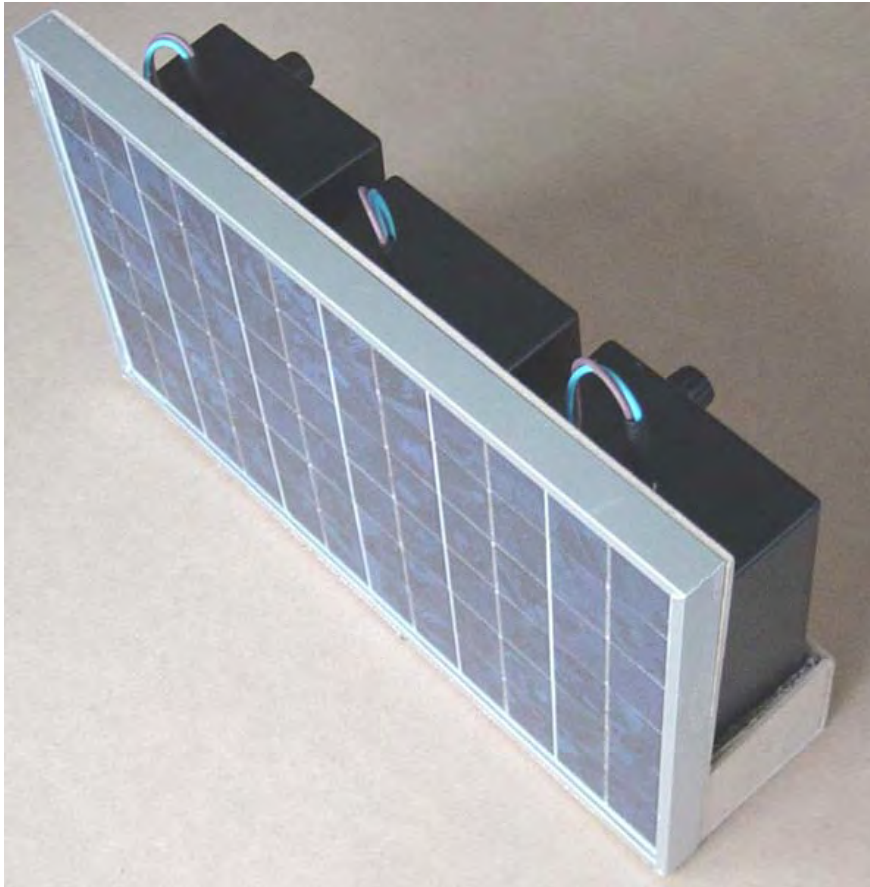

In this implementation, the two mobile units with adjustable light level, have their LED arrays set lower down to reduce the shadow cast by the control knobs. The charge rate is not unduly high, but charging NiMH batteries is not particularly easy as the <http://www.powerstream.com/NiMH.htm> web site explains in detail. A press-button operated chain of single LEDs and different voltage zener diodes could be added to each unit to indicate the present level of charge in each battery.

Patrick Kelly
<http://www.free-energy-info.tuks.nl/>

Chapter 15: You Are Being Deceived

Without your knowledge, you were stolen from your parents at birth and automatically became the judicial property of a commercial company pretending to be your government. What you think of as “your” birth certificate is **proof** of this action. The biggest secret is that your government is a collection of commercial companies whose only real purpose is to take as much money from ordinary people as they can, using unlawful actions. Their sole intention is to keep you poor, in fear and doing whatever they tell you to do.

The Situation in the UK

This is a large subject, so let's take it step by step and start with people who were born in the UK. I will discuss the position of a typical native of what is called “The United Kingdom of Great Britain and Northern Ireland”. The average person living in this area believes that he is a free person living in a democracy which is governed by elected parliamentary representatives of the people, protected by legal statutes introduced by Parliament and enforced by police officers who are there to ensure your protection where physically possible. Those who are better informed, believe that the Magna Carta signed in 1215 affords them substantial rights and freedoms.

None of that is true. Not a single item.

The inhabitants of this region fall into two categories which are “landowners” and “everyone else”. The term “landowner” is, of course, ridiculous. No human can own land. The only way that you can own something is if you create it from materials which you own, if it is given to you as a gift by the rightful owner, or if you buy it from the rightful owner.

If I state “I own the whole of the planet Mars” it does not give me any genuine ownership of the planet. What has happened on planet Earth is that an individual stakes out an area and says “This is my land, I own it, and I will kill anyone who says that I don't”. That can certainly frighten most people away from the area, but it does **not** give the squatter genuine ownership of the land. Consequently, no human owns any land whatsoever, and it is not possible for any land to be bought as there is no previous human owner of the land in question.

Killing a squatter on the land and claiming ownership of that land by right of conquest is farcical. It is true that violent bully-boys take control of areas of land through intimidation and peaceful people dare not oppose them. No human has any more rights than any other human, but violence and the threat of violence have been used to create a notional group of people called “landowners”. Is it right? Is it just? No, of course not, but it is what has happened.

This violent situation resulted in there being two groups of humans in the country. The violent “landowners” called “Knights”, “Lords”, “Barons” or some other irrelevant title, who join together to maintain what they have taken, and then there are the other people who have been intimidated by them, sometimes called “serfs”, whom the landowners feel free to rob on a regular basis through sheer intimidation.

Already, there was a certain degree of deception being practiced by the landowners as they said to the serfs “we will protect you, and in return, you can work for us and pay us to protect you. This, of course, was a complete con, because if it wasn't for the landowners, there would be no need at all for “protection” from other landowners. And, oh yes, the protection required the serfs to put their lives on the line as part of the “protection” racket.

There was one group of landowners who operated more by trickery than by sheer force of arms. Going under the general title of the “Church” their influence came from telling people that when they die that they would not go to “heaven” if they were not servants of the Church. That technique worked very well and even influenced the head honcho of the landowners - the Monarch who was the ultimate “landowner”. Don't get me wrong. I'm not saying that it is wrong to worship God, follow a moral code, live an upright and blameless life, **but**, doing that has nothing whatsoever to do with being subject to any human or human organisation.

A point which you have probably missed is that the ‘landowners’ considered the serfs to be sub-human “things” and not people at all. Unfit to, and incapable of, owning land under any circumstances. Considered to be ‘goods and chattels’ owned by the landowners. At that time, “serf” was an alternative word for “slave”.

It is not possible for one human to genuinely “own” another human. Parents do not own the children born to them. They have a duty and a responsibility to nurture them and care for them and ideally, love them, but they do not

own them. The weird notion which landowners have that they “own” humans is as false as anything can get. Slavery is another act of violence. Only a very ill-informed person believes that slavery has been ‘abolished’ as it is more widespread today than at any other time in all of recorded history, and it has nothing whatsoever to do with skin colour.

In the well-known year of 1066, another violent ‘landowner’ arrived in England and by force of arms, imposed Roman law on all of England. You will recall that Rome was very heavily into slaves and the slaves had no rights or privileges, no possessions and no protection, in spite of the fact that in reality, every one of them actually had equal entitlement to the rights claimed by their so-called “owners”, both slaves and masters being human beings. So, please understand clearly, that Roman law encompassed the notion of people being called slaves, and owned as “things”.

In 1213, King John was excommunicated and that frightened him so much that he signed a contract with the Pope. The contract is known as the “Treaty of Verona” and it undertook to introduce Rome’s canon law to England, which made Archbishop Stephan Langton, the effective ruler of all of the country. The contract was supposed to give the Pope ownership of all of the lands, people, animals, etc. of all of King John’s kingdom. According to this contract, the Vatican owns all of England and all of the British Commonwealth countries.

This is, of course, a rubbish document. Firstly, King John did not genuinely own any land of any description and never could have. Secondly, King John did not and never could have owned any of the people living on that land. Thirdly, a contract cannot be signed on behalf of a third party, so his signature could never, ever have any genuine effect on the people of the land. If that were not the case, then I could sign a contract on your behalf, guaranteeing that you would pay me a million pounds. It couldn’t happen and if it did, it would be meaningless. The Treaty of Verona contract only applies to the signing parties, to have any effect on the people of the land would require them to be fully informed of the consequences and give their consent to the contract, and that never happened.

In an attempt to be cunning, the treaty was worded so as to make it appear to apply to the direct descendants of both the English monarch and the direct descendents of the Pope, namely, his successors. Personally, that seems highly doubtful to me as that would make it, in effect, a contract between people who have not agreed to it or signed it, and it is by no means obvious how a contract could be binding on people who are not party to it and who have not signed it.

However, just two years later in 1215 the landowners forced King John to sign a contract called the “Magna Carta”. It is highly doubtful that a contract where one of the parties is intimidated into signing, has any actual validity, but that aside, the contract was made under the conditions prevailing at that time. The landowners, called “Barons” or “Free men” in the document, were insisting on a continuing agreement between them and the monarch. The contract has nothing to do with the serfs who were considered “things” with no rights at all. Today, members of the general public, who are actually the descendants of those serfs, read the Magna Carta and not understanding the situation when it was written, mistakenly think that it speaks of them. It doesn’t. The objective was actually an attempt to strengthen the Treaty of Verona.

This power-play continued in 1600 when a private company was set up. It is still in place today and it is called “The Ministry of Justice” D-U-N-S Number 22-549-8526, Directors: Lord Falconer of Thoroton. Today, all Magistrate Courts are private for-profit companies subsidiaries of this main commercial company and not, as most believe, part of the government of the UK.

The next step came in 1689 with the “Bill of Rights” whose purpose was to make the monarch subject to Parliament. Again, this was introduced with the intention of ensuring that no monarch could set aside the Treaty of Verona and deny the Pope (supposed) ownership of the British empire and all the people in it. The Bill of Rights settled the succession of the crown, creating a Dynasty which has been maintained right up to now. The only powers of a Constitutional Sovereign created by this “Bill of Rights” is to warn, to guide and to be informed, just that and nothing else. In 1701 there was the Act of Settlement to confirm the line of royal succession.

In 1694 a privately owned company called “**The Bank of England**” was formed. The name gives the impression that it is a government organisation, but that is not the case. Actually, the UK has no government but instead there is a set of interlocking, privately owned, for-profit commercial companies designed to give the false impression of a government. For example, **the House of Commons** is a commercial for-profit company (number UC2279443). **The Labour Party** is a commercial company which trades under the name of “Allister Darling MP”. **The House of Lords** which is the highest court in the land is a private company.

Then there is the **United Kingdom Corporation Ltd.**, formerly known as the “United Kingdom plc”. In passing, anyone who has a National Insurance Number, is automatically deemed to be an employee of the United Kingdom Corporation Ltd. The Company policy of that corporation requires each employee, to pay tax and follow all the

legislative rules (“statutes”) of that corporation. Anyone who breaks the rules of the corporation will be disciplined under the legislation of that corporation.

The police forces of the United Kingdom Corporation are all companies which can be seen from their company registrations, and their job is to enforce the rules of the Corporation. **Every court** in the land is a company. There is a commercial company called the “**Secretary of State for Trade and Industry**”, which ceased trading on 4th November 2002 and yet it still operates TV licensing, taking £3 billion per year through it’s subsidiary commercial private limited company called “Consignia (Customer Management) Ltd.”, which is part of it’s group of 35 subsidiary companies.

This continues to a ridiculous level where the company called “**The Devon and Cornwall Police**” has been taken over by a company called SouthWestOne which is one of a group of companies whose Ultimate Parent Company is IBM, but this Police Constabulary is a public service paid for by the taxpayer and given an annual budget of £256,800,000 taken from members of the public. Isn’t IBM a lucky company to be given £256,800,000 per year to help it run it’s business at a profit !

Equally ridiculous is the **Lancashire County Council** which was incorporated as a company (IP00666C) in 2002. It’s registered office was 3rd Floor, Christ Church Precinct, County Hall, Preston. It was completely dissolved on 25th January 2008 and all of it’s Assets and Liabilities were transferred on 12th November 2007 to another company - “The Blues and Twos Credit Union Ltd.” whose registered address is Lancashire Police Headquarters, PO Box 77, Hutton, Preston.

The screenshot shows a web interface for searching company records. At the top, there are navigation links like 'Home', 'Bookmark site', and 'Links'. Below that, there are links for 'About us', 'Forms', 'Press Desk', 'Careers', and 'Contact us'. A search bar contains the text 'Select Search Results on "LANCASHIRE COUNTY COUNCIL"'. Below the search bar, there are two search forms. The first form has 'Company Name:' and 'Company Number: IP00666C' fields. The second form is identical. Between the two forms is a table with the following data:

Number	Status	Name	Action/Event : Date
IP00666C	C	LANCASHIRE COUNTY COUNCIL	Company Removed
IP00666C	D	LANCASHIRE COUNTY COUNCIL	Dissolved 25/01/2008

If you feel that these things are all straightforward and aboveboard, then I would like you to change a bundle of £3 notes for me, and as well, perhaps you would be interested in buying the Eiffel Tower.

The ordinary people resident in the UK are descended from the slaves called “serfs” and the only protection which they have is the “Common Law”, upheld by a policeman or a policewoman, each of whom receive authority through, and only through, their personal oath of allegiance to the monarch and the monarch’s oath to uphold Common Law. The Police Authority for whom the policeman or policewoman work, actually has no authority itself as, being a company, it cannot swear an oath. Policemen and policewomen have a duty to uphold Common Law and to protect and serve members of the public.

UK Common Law deals with a human causing death or injury to another human, damage to property or acting fraudulently in dealings with others. It is based mainly on the earlier findings of courts and is modified from time to time if it is found to be unjust. Surprisingly, the main corrections are supposed to come, not from judges, but from juries. A jury is the most powerful element in any court of law for they have the power to dismiss a case and even to go against the law. A jury has “discretion” and they can order the judge to find against the law if they believe that in the particular case which they are trying, the law would be unfair, so they adjudicate on both the individual case **and** on the underlying law. Judges do not always bring this to the attention of jurors.

A system has been set up by the Law Society with the express intention of enslaving members of the general public. They have taken words from the English language and redefined them to create another language called "Legalese".

The translation for this language back into English is given in the publication "Black's Law Dictionary". The average member of the UK public is generally unaware that Legalese is being spoken and that what sounds like a simple, innocuous question in English, is actually a highly-loaded and underhand attempt to cause him both distress and unwarranted financial loss.

The objective of a lawyer is to make money for his commercial company and particularly for himself. To help them, lawyers have set up a system of "statutes" which are supposed to have the force of law, but which, being crafted by their sister parliamentary commercial companies, are **not** the law. These things are "statutes" and they don't actually apply to humans. Being wholly invented "legal" devices, they only apply to other "legal" things, which are essentially, just pieces of paper. Since a piece of paper does not own any money or goods, to get any real financial gain from their actions, they need to trick a human into taking on responsibility for a piece of paper. If they succeed in this, then they can demand money from that piece of paper and get the unfortunate human to actually provide the money even though the fictitious legal charges do not apply to that human.

Meet Your Strawman

In order to do this, they have to persuade the human to enter into a contract with them, agreeing to pay them money, essentially, for nothing in return. Their main trick is creating a fictitious legal identity using the name of the human. This is done by creating a "Birth Certificate" in the same name. Most parents mistakenly believe that they **have** to register the birth of their child, which is actually **not** a requirement under the law (which **does** apply to humans, as opposed to "statutes" which don't apply to humans).

In spite of their mistake, the fictitious legal "person" produced by creating the Birth Certificate document, the human who has the same first and last names as those recorded on the birth certificate, has no actual link to that document unless he can be tricked into agreeing to be linked to it.

All of the company statutes such as Income tax, Council tax, television licence, parking tickets, and the like are not being charged against a human but instead are being charged against the legal fiction with nearly the same name, sometimes called a "strawman". If the human refuses to agree that there is a link, then the invented charges collapse and the human is left alone until the next attempt to fool him. At this time there is a very nicely produced video <http://www.youtube.com/watch?v=ME7K6P7hiko> which explains the fiction of the strawman legal document.



The people who work for one of the commercial companies called Police Forces have two entirely different roles. As a policem**an** or policew**oman** they have a duty under common law to protect members of the public, and serve them by upholding common law. They have an entirely different role as a police **officer** dedicated to making money for their employer by imposing all kinds of fines, charges and penalties under a series of statutes invented by their sister companies. These financial penalties do not actually apply to humans, and so trickery must be employed in order to con the human into undertaking to pay when there is no requirement for the human to do so.

A Police **Officer** is a corporate employee who acts as a Revenue Collector for the Corporation and enforces Acts of Parliament.

A Police **Community Support Officer** is a Corporate employee who has no powers whatsoever, and holds no Oath of Office. They are given a Warrant Card and told to keep it because while they don't need it now, they will need it at some point in the future. Without an oath to the monarch, they have no authority at all.

The British people live in a "common law jurisdiction". This means that no Civil Law Statute applies to them at any point **unless the individual consents to it**. If asked to give your name, do not do so as that is a trick which places you into the realm of civil law which does not apply to you at all unless you consent to be placed under it. You are not obliged under common law to answer the question which asks your name and/or address. The police officer will be following training and may well not be aware that trickery is involved, never having been trained in common law and their duties under it, to each member of the public.

The Comments of John Harris

John Harris of the <http://www.tpuc.org/> web site makes the following points:

The deception of “Joinder” or more aptly named “pretensive joinder”: The human is asked for his full name, address and date of birth in order to establish the LEGAL PERSONALITY, the address of the LEGAL PERSONALITY and the date on which the LEGAL PERSONALITY was created. Once Joinder has been established, they can then offer that LEGAL PERSONALITY a contract. But, they need the consent of the human to act on behalf of the fictitious LEGAL PERSONALITY and so the human is asked “do you UNDERSTAND?” The human is then required to sign at least one piece of paper saying that he is the LEGAL PERSONALITY and that as the LEGAL PERSONALITY, he UNDERSTANDS.

This is deception as “UNDERSTAND” is taken to mean “STAND UNDER” and has nothing to do with the human comprehending anything. During any process where a human has any dealing with Corporation Officers, he is asked “do you understand?” and that is simply about **consent**. He is being asked to represent the LEGAL PERSONALITY and give the Corporate Officer authority over him.

The deception of “Notice”: In Legalese, a “notice” is not a bill or a demand, instead, it is an offer of contract. When the offer has been made, the LEGAL PERSONALITY must be established through Joinder because the LEGAL PERSONALITY is only a piece of paper. Consequently, the human has to agree to represent that piece of paper by saying “I understand”. Fixed penalty notices are the same as all, and any, statements made: they are simply, self-perpetuating Contracts. Making a statement to police is exactly the same - a self-perpetuating contract.

The deception of “Includes”: The Inclusion of one is the Exclusion of another – this is a maxim (an established, unchallengeable fact). A summons (invitation) for watching TV without a licence has “We will present any evidence found of your watching TV without a licence, which may include a statement taken under caution by one of our Enforcement Officers”. But the legalese “may” translates into “must”, but if you make a statement with your name, address and confirmation of watching TV, then the court issues summary judgement as you have already incriminated yourself and the court has nothing to decide.

The deception of “Summons”: Summons is synonymous with “invitation” which is a choice. They are inviting a LEGAL PERSONALITY to a Corporate place of business. The LEGAL PERSONALITY is just a piece of paper, a BIRTH CERTIFICATE created by the United Kingdom Corporation and it is **not** the human. You can’t be forced into a contract, so they have to deceive you into entering into one without realising what you are doing. They are using deception as every Magistrates Court is a trading name of the commercial company called “The Ministry of Justice” D-U-N-S Number 22-549-8526 which does not have a Parent Company listed meaning that it is a Parent Company. Directors: Lord Falconer of Thoroton, date of incorporation 1600. Legal people on being shown this registration, responded by saying that if this information is genuine (which it is), then the UK has been lawless for more than 400 years because the whole Justice System is being dealt with by a company.

Deception of the Name: If you go to a Court (which is a Corporate place of Business) as the Accused, you will be asked to confirm your Name, quoting the full name shown on your birth certificate, which is the LEGAL PERSONALITY. Titles such as Mr, Dr, Lord, PC, QC, or whatever are not asked for as they are not required. The “Accused” is actually the LEGAL PERSONALITY which is the name on the birth certificate, so when they ask for the person’s NAME, they are talking to the LEGAL PERSONALITY and **not** the human. This is because a human **cannot** exist in the legal world - only pieces of paper can, and that is something which they are very careful not to tell you.

This is a really key issue. Natural Law and Common Law are the only laws which apply to humans and they deal only with harming other people or causing them loss, and outside of those restrictions, a human has free and unlimited entitlement to do anything he chooses which complies with these principles. As opposed to this, Acts of Parliament, “Statutes” and Statutory Instruments “Contracts” do not apply to the human but only to the piece of paper which is the LEGAL PERSONALITY and which has no reality. As the legal fiction of the LEGAL PERSONALITY was created by the company called “the United Kingdom Corporation”, it is that company which gets to say what the rights and duties are for that piece of paper.

The deception of the Birth Certificate: When a person is born in Britain, the mother and father submit a Birth Certificate Registration Form, which is a piece of paper. There is no requirement under common law to do this. When any limited company or corporation is set up, there is always a Certificate of Registration in order to create it’s LEGAL PERSONALITY and that is a piece of paper. Please note that a British Birth Certificate states quite clearly that it is **not** evidence of identity, that is, it has nothing to do with a human. Marked on it is “Crown Copyright” showing clearly that it does not belong to an individual and was created by “the crown” which is not the monarch but is the independent ‘City of London’ represented by the Law Society and acting on behalf of the private owners. This act of Registering a child, makes that child a “ward of the court” which means that the child can be taken away from the parents at any time.

The deception of Registration: If I lawfully own a vehicle, then it cannot be taken away from me and crushed as that would constitute a criminal act and considered theft, no matter who takes it. However, if I Register my vehicle, then, without realising it, I hand ownership of the vehicle over to the registering company as a free gift. They acknowledge the gift by issuing me with a piece of paper stating that I am "the Registered Keeper" of their vehicle, to which they assign a number in their registration records of the vehicles which they own (although they will not pay for the upkeep of their vehicles).

John also asks:

Do you believe Parliament is elected to Represent the people and their wishes? It isn't, they are Directors of a commercial 'for-profit' corporation and so, nothing will ever change.

Do you believe in Politics? There is no such thing.

Do you believe that the only way to sort the UK out is to elect a different Political Party? It makes no difference as all you are doing is choosing employees of a commercial company, and the owners dictate what the company does, no matter who the corporate serving officers may be.

Do you believe that Acts of Parliament ("Statutes") are Law? They aren't.

Do you believe that Statutory Instruments are Law? They aren't.

What The UK Police Can, and Can't Do

Posted September 26th, 2008 by Guy_Euden

Do you feel intimidated when pulled over? Do you feel intimidated when stopped in the street? Do you feel that you are obliged to give them information or answer their questions? If your answer is "yes" to any of these questions, then you **don't** know your rights. A police officer is not what he was many moons ago. In bygone days they cared for their employers (yes you), they actually wanted to help you, they wanted to solve crimes, they had compassion, a sense of fair play and in response to this they earned our respect and admiration.

ALL of that has changed! Police officers are now Revenue Agents plain and simple and if any police officer is silly enough to think that's not true, or just wish to profess it isn't, then let him try not giving out fixed penalties for a month and see if a talking to is not the result! The truth is that they are now your adversary and that is not meant in a violent way, more like a game of who can get who to do as they're told, and they are trained to get from you what they need in order to actually fine or arrest you by actually getting you to consent to it. Let's quickly look at all laws that don't include Death or Injury to others, Damage to another's property or using fraud in your contracts.

OK, these three very heavy crimes are all you can truly be guilty of - YES it's all you can truly be guilty of!!! Anything else is just STATUTE LAW and the simple to remember definition of this law is "laws that only apply if you consent to them"!! Here, look at the definition of a Statute: "Legislative rule of society given the force of law **by the consent of the governed**". Yes look at the last four words, "CONSENT OF THE GOVERNED" that is you!! So, if you don't consent, then they can't do anything. Yes, I know what you're thinking, but it really **is** that simple. Ok, an officer walks up to you and says "can I ask you some questions?" Don't consent. Ask him "what is the nature of the intended detention?". Record the conversation and let him see that you are doing this. Use your mobile, as 99% of mobile phones available today have recorders so go for it! If he says that you cannot record this conversation, then what he is in fact saying is, "yep you guessed it - I don't consent to be recorded!!". So, you simply say "Ok, am I free to go?"

The simple fact is that they **need** your consent, and they have some very cool tools to use to get it, one is intimidation, and another is acting. They act like they are your friend. They act like they care. They just ACT! This is to put you off guard and most people sing like canaries!! Their other weapon of choice is Inconvenience. You don't have time to waste playing their game, so you talk in order to get away quicker, and wham! - they have their result! If you are pulled over for an offence under an act, for example, speeding, seatbelt or some other infraction, it is all part of the "Road Traffic Act of 1988 keyword is "ACT" and believe you me what a merry old act it is, it is pure stage play.

When issuing a ticket they **need** your name so SHUT UP! Don't argue with them as that is "adversarial" so just SHUT UP! They need your name and date of birth to confirm which corporation they are going to give the bill of exchange to (bills of exchange defences are simple but we are not doing those right now). So don't provide a name, or date of birth, or address. Don't give them anything to work with, don't say a single word no matter what coercion they try, hell they might even go for some "good cop bad cop" stuff this is great to watch when you are

fully aware of their lack of power, it's like watching "EastEnders". If they read you your rights you have to say that you understand in order for handcuffs to be put on you. **Again, your consent is necessary** (get it?) don't say a word!!

Now these Officers of Revenue don't like the grim realisation that they have no power. You could get arrested, yes I am afraid that they can still arrest you, but the worst that they can do is keep you for a few hours, so get some sleep, oh and if you have a "notarised claim of right, with a schedule of charges for arrest and detention", then sleep even sweeter because these fools are paying you to learn that they have no power! I know that getting arrested isn't nice, they know this, that's why its one of their tools to get you **to consent to their unnecessary and unlawful penalties**.

But if you don't stay quiet, then they will always have power over you. Now if they are going to arrest you, one nice way of them playing into your hands is if you say these few of words: "Officer, I am a peaceful man, there will be no violence, but you are obliged to note that if you are going to arrest me it will be under protest and duress at all times and I reserve all of my rights at all times, and I waive none of those rights at any time for any cause or reason". If they take you to the station remember DON'T SAY A SINGLE WORD. Hell you might get a new name! "JOHN DOE". If they try to fingerprint you, tell them that you do **not** consent to this. If they try to get your DNA then tell them that you do **not** consent to this. If they touch you, tell them, "Officer I do not consent to be touched at all".

If you make it known that you know your rights then they will leave you alone. Trust me, they will only act illegally if you continue to let them do so. Remember that any "legal" acts that they choose to quote are powerless, a clawless, toothless tiger.... they have no power if you don't consent.

Summary:

The present UK (and world) situation is designed to confuse you. The UK is a "Common Law jurisdiction" which has had a spurious and fake "legal" system added on to it in order to rob you blind. The average inhabitant of the UK is bound to keep the common law or suffer the consequences. The common law requires a human not to kill or injure another human, not to damage or steal his property and not to swindle him.

The spurious "legal" system introduced by the Law Society (who consider all other humans as inferiors), is designed to steal from those humans by deception and fraud. It operates by tricking humans into inadvertently and unknowingly entering into a contract to pay money to someone who will not provide anything of worth in exchange.

This is done by using the legalese language which has taken words from the English language and changed their meanings without making the changes of meaning made clear to the public. This covert and surreptitious method is used to get a human to represent a legal fiction which is a piece of paper and undertake to pay invented debts attached to that piece of paper.

The average UK resident believes that there is a UK government, when in fact, there is no actual government, just a commercial company pretending to be a government, namely, the company called "The United Kingdom Corporation Limited". People are fooled into "voting" for the election of corporate officers in this company in order to make them believe that there actually is a government where no government exists.

This hateful "legal" system is there solely to enslave and rob ordinary people living in the UK and there appears to be no way to circumvent it. I have seen a calculation which estimates that on average, ordinary people in the UK have 80% of their income taken from them in taxes. So, for every £100 they earn, they only receive £20.

A self-employed person may be able to avoid paying Income Tax, Council Tax, TV licence and some other minor taxes. An employed person is tied to a "legal entity" employer which cannot escape the legal snare and so is forced to take Income Tax, National Insurance and Child Support amounts off a person's earned payment before the remainder is given to the employee.

Unfortunately, even self-employed people can't escape the thieves because they add their massive charge on to essential items which are not sold to people by name. For example, I have been told that 85% of the cost of a gallon of fuel for a vehicle is tax. That means that if I buy £100 of fuel, it really should have only cost me £15 as that is the cost of finding it, extracting it, refining it, transporting it and making a profit on selling it. My £85 has been taken against my will, by people who are not entitled to it.

If I buy almost anything in a shop, then 17.5% of the selling price is taken from me and given to someone who doesn't deserve it. In reality, it is much more than that because the item purchased was transported to the shop using fuel which was heavily taxed, and I have to pay that tax indirectly in the raised cost of the item. Also, the

shop has to have heating and lighting, both of which are powered by heavily taxed fuel, which raises the price which I have to pay on the item. Then, there is the tax on the company and the tax on the company for having employees, both of which have to be covered in the price which I am charged. You can see why the person who costed out how much is really paid in tax, came up with an overall figure of 80% of a person's earned income. Even a self-employed person can't escape paying a major amount of indirect tax. The often-quoted phrase "we live in a free country" does not seem to have any basis in fact. So, how about "the land of the brave and the land of the free" across the Atlantic ocean, do they fare any better?

The Situation in America

In 1606, King James I the King of England set up a commercial enterprise called "The Virginia Company" with himself as the main stockholder. The Virginia Company was formed in anticipation of the imminent influx of white Europeans, mostly British at first, into the North American continent. The Virginia Company of London (also called the "London Company") was chartered by King James with the object of colonising the eastern coast of North America between latitudes 34°N and 41°N. It's shareholders were Londoners. The Virginia Company claimed ownership of most of the land that we now call America. The Virginia Company (the British Crown and the bloodline families) claimed rights to 50% of all gold and silver mined, plus percentages of other minerals and raw materials, and 5% of all profits from other ventures.

As has been already remarked, no human can own land as there is no way that genuine title to the land can be bestowed on any human, short of God giving him a written deed of ownership as a gift. No human can buy land from another human or organisation as they didn't genuinely own the land in the first place. King James was essentially, no different from any other man and he had no justification for blithely claiming ownership of another country. Even being the first squatter on the land (which he wasn't) does not give any man ownership of that land. Consequently, his was, and is, a spurious claim with no basis in fact or any form of justification.

At this time, America does not have a government because "The UNITED STATES" is a commercial company. The term "United States" means a Federal corporation. The US President is the President of a commercial corporation and American citizens are, in effect, the employees of that Corporation. This present situation was sneaked in by the covert actions of the Americans who organised and ran the civil war with the intention of taking lands and assets from people who lived in the South. Most people imagine that, say, Virginia, is a part of the American nation under the American government. However, this is not true as every one of the "States" is actually set up as a commercial, for-profit, company, under the parent company "The United States of America". So the reality is that instead of being a State of the Nation, the "State of Virginia" is the name of a commercial for-profit company.

The Vatican claims that it owns Britain and all of the commonwealth countries. Britain claims that it owns America as a British colony. The King of England provided financial backing to both sides of the Revolutionary war and believed that the lands of the Virginia Company were granted (on lease) to the colonies under a Deed of Trust and therefore they could not claim ownership of the land. They could pass on the perpetual use of the land to their heirs or sell the perpetual use, but they could never own the land itself as ownership was supposedly retained by the British Crown.

You may be interested to know that the Vatican's system of law is based on the ancient Roman system and in Rome, the seat of power for Caesar was called "Capitol Hill" where Caesar would meet with 'the Senate'. The Pope believes that he can abolish any law in the United States (Elements of Ecclesiastical Law Vol. 1, 53-54). The Pope's laws are supposed to be obligatory on everyone.

The conglomeration of privately owned commercial corporations know as "the United Sates of America" go along with the same old ridiculous scam of considering American human beings to be "slaves" under Roman law. Consequently, no American can own property because slaves can't own property. If an American reads the Deed to a property which he thinks that he owns, he will discover that he is listed as a "Tenant" (Senate Document 43, 73rd Congress, 1st Session).

After the first 21 years from the formation of the Virginia Company, all 'duties, imposts and excises' paid on trading activities in the colonies were paid directly to the British Crown through the Crown treasurer. Queen Elizabeth II of Britain, controls and has amended U.S. Social Security: Statutory Instrument 1997 No. 1778 The Social Security (United States of America) Order 1997.

The American Inland Revenue Service Publication 6209 is form 1040 which is to be used for tribute paid to Britain. Americans are considered to be slaves to the Queen and own absolutely nothing (Senate Document 43). America's Social Security is not insurance or a contract, nor is there a Trust Fund. The criminal courts on the lands of the Virginia Company were to be operated under Admiralty Law, the law of the sea, and the civil courts under common law, the law of the land. This is a crucial point. The United States of America is not a country, it is

a corporation owned by the same Brotherhood bloodlines who owned the Virginia Company, because the USA is considered to be the property of the Virginia Company.

There is a "USA" which is the 68 square miles of land west of the Potomac River on which is built the federal capital, Washington DC and the District of Columbia, also the US protectorates of Guam and Puerto Rico. And then there is a "usa" the "united states of America" which are the lands of the various states. These lands are still supposedly owned by the British Crown as the head of the Virginia Company.

The Act of 1871 created a new, altered Constitution. The title was changed to capital letters and the word "for" was changed to the word "of". That is, "The Constitution for the united states of America" was altered to "THE CONSTITUTION OF THE UNITED STATES OF AMERICA".

An American cannot use the Constitution to defend himself because he is not a party to it. "The People" does not include ordinary U.S. Citizens. The Act of 1871 also created a separate form of government for the District of Columbia, which is a ten mile square parcel of land which is governed with British Admiralty law, U.C.C. (Acts of the Forty-First Congress, Section 34, Session III, chapters 61 and 62).

When Americans agree to have a Social Security Number, they surrender their sovereignty and agree to become franchisees of the United States (which is supposedly the Virginia Company of the British Crown). Americans are led to believe that there is only one United States and that the Federal government is the rightful government. The use of lower/upper-case characters is making a legal statement. If you are American, then you should notice that when you receive any correspondence relating to government, law or anything to do with finance or taxation that your name is always spelt entirely in block capitals.

Your name in block capitals is not you. It is a corporation set up by the 'government' Corporation through the treasury department at the time of your birth. Any time that a child is born, a corporation/trust is created using his or her name in block capitals. One definition of "a human being" is "a corporation treated as having the rights and obligations of a person" while the definition of a "natural person" is 'a real human being', as distinguished from a corporation, which is often treated at law as being a fictitious person.

Everything in the "United States" is "For Sale": roads, bridges, schools, hospitals, water, prisons, airports, etc. (Executive Order 12803). Americans are Human capital (Executive Order 13037).

The Emergency Banking Relief Act of 9th March 1933, defined the American people as legally, the **enemy** of the United States Government and the private, international Federal Reserve System became the Government of the United States.

The national flag of the United States always has a gold fringe when displayed in court or federal buildings, federally-funded schools and the uniforms of US troops. Under the International Law of the Flags, a gold fringe indicates the jurisdiction of commercial law, also known as British Maritime Law, and in the US as the uniform Commercial Code or "UCC".

George Bush launched a 'war on terrorism' on behalf of a private Corporation, to further the goals of that Corporation. It had nothing to do with 'America' or 'Americans', because those are very different legal entities. The United States Corporation owns the United States military and everything else that comes under the term 'federal'. It is not the duty of the US police to protect Americans. Their job is to protect the Corporation and arrest code breakers (Sapp v. Tallahassee, 348 So. 2nd. 363, etc.). There are no Judicial courts in America and there have not been since 1789. Judges do not enforce Statutes and Codes but instead, Executive Administrators enforce Statutes and Codes. The most powerful court in America is not the United States Supreme Court but instead, it is the Supreme Court of Pennsylvania (42 Pa.C.S.A. 502). Pennsylvania is the keystone state.

The FCC, CIA, FBI, NASA and all similar organisations were never part of the United States government, even though the "US Government" held shares of stock in the various Agencies. (U.S. v Strang, 254 US 451, Lewis v US, 680 F.2d, 1239).

Americans may think that their government and legal system is pegged in some way to the Constitution, but it is not. The United States, like Britain and elsewhere, is ruled by commercial law to overcome the checks and balances of common law. It is a monumental fraud.

The web site http://www.youtube.com/watch?v=klwWcp9eiPw&feature=player_embedded lists what it considers to be a series of little-known facts about America. It says:

"The IRS is not a U.S. government agency. It is an agency of the IMF which in turn is an agency of the United Nations. The United States has **not** had a Treasury since 1921 as the U.S. Treasury is now the IMF. The United States does not have any employees because there no longer is a United States. The FCC, CIA, FBI, NASA, etc.

were never part of the U.S. government but are privately owned companies. US Social Security numbers are issued by the UN through the IMF, (the SS5 form does not state who issues it). There have been no Judicial Courts in America since 1789. There have been no Judges in America since 1789. According to GATT, Americans must have a Social Security Number. New York City is defined in the Federal regulations as the United Nations. Social Security is not insurance or a contract and Social Security cheques come directly from the IMF which is an agency of the UN.

All Americans are slaves and so can own absolutely nothing, not even what they think of as being their own children. The most powerful court in America is the Supreme Court of Pennsylvania. The King of England financially backed both sides of the Revolutionary War. Americans can't use the US Constitution to defend themselves because they are not a party to it. Britain is owned by the Vatican and the Pope claims to own the entire planet through the laws of conquest and discovery (Papal Bulls of 1495 and 1493). The Pope has ordered the genocide and enslavement of millions of people (Papal Bulls of 1455 and 1493). The Pope's laws are obligatory on all Americans. "The People" does not include ordinary Americans. (Barron v City Council of Baltimore 32 US 243)".

When you become aware of these things, it becomes easier to understand why voting in a Presidential election can never make any difference - after all, he is only the President of a commercial company whose corporate policy is set by the owners of the company and not by the President. It also explains what these commercial companies have done and are still doing through their agencies such as the CIA.

The fractional reserve policy perpetrated by the Federal Reserve, which has spread in practice to the great majority of banks in the world, is, in fact, a system of modern slavery. Think about it: money is created out of debt. What do people do when they earn debt? They submit to employment to pay it off. But if money can only be created out of loans, how can society ever be debt-free? It can't, and that's the point. And it is the fear of losing assets coupled with the struggle to keep up with the perpetual debt and inflation in the system, compounded by the inescapable scarcity in the money supply itself, created by the interest which can never be repaid, that keeps the wage-slave in line, powering the pyramid which benefits only the elite at the top of the pyramid. At the end of the day, for whom are you really working? The banks. Money is created in a bank and inevitably ends up in a bank. They are the true masters along with the corporations and governments which they support. Physical slavery requires people to be housed and fed, economic slavery requires people to house and feed themselves.

Michael Rivero has put together a concise statement on the situation in America, and his statement is at <http://whatreallyhappened.com/WRHARTICLES/allwarsarebankerwars.php> where he says:

I know that many people have a great deal of difficulty with understanding just how many wars are started for no other purpose than to force private central banks on to nations, so let me share a few examples, in order that that you can understand why the US Government is engaged in so many wars against so many foreign nations. There is ample precedent for this.

The United States fought the war of the American Revolution primarily over King George III's Currency Act, which forced the colonists to conduct their business only using printed bank notes borrowed from the Bank of England at interest. After the revolution, the new United States adopted a radically different economic system in which the government issued its own value-based money, so that private banks like the Bank of England were not siphoning off the wealth of the people through interest-bearing bank notes.

"The refusal of King George 3rd to allow the colonies to operate an honest money system, which freed the ordinary man from the clutches of the money manipulators, was probably the prime cause of the revolution". -- Benjamin Franklin, Founding Father

But bankers are nothing if not dedicated to their schemes to acquire your wealth, and they know how easy it is to corrupt the leaders of a nation. Just one year after Mayer Amschel Rothschild had uttered his infamous statement: *"Let me issue and control a nation's money and I care not who makes the laws"*, the bankers succeeded in setting up a new Private Central Bank called the First Bank of the United States, largely through the efforts of the Rothschild's chief US supporter, Alexander Hamilton.

Founded in 1791, by the end of its twenty year charter the First Bank of the United States had almost ruined the nation's economy, while enriching the bankers. Congress refused to renew the charter and signalled their intention to go back to a state-issued value-based currency on which the people paid no interest at all to any banker. This resulted in a threat from Nathan Mayer Rothschild against the US Government: "Either the application for renewal of the charter is granted, or the United States will find itself involved in a most disastrous war". Congress still refused to renew the charter for the First Bank of the United States, whereupon Nathan Mayer Rothschild railed, "Teach those impudent Americans a lesson! Bring them back to colonial status!"

Financed by the Rothschild-controlled Bank of England, Britain then launched the war of 1812 to re-colonise the United States and force them back into the slavery of the Bank of England, or to plunge the United States into so much debt they would be forced to accept a new private central bank. The plan worked. Even though the War of 1812 was won by the United States, Congress was forced to grant a new charter for yet another private bank issuing the public currency as loans at interest, and that was the Second Bank of the United States. Once again, private bankers were in control of the nation's money supply and cared not who made the laws or how many British and American soldiers had to die for it.

Once again the nation was plunged into debt, unemployment, and poverty through the plundering of the private central bank, and in 1832 Andrew Jackson successfully campaigned for his second term as President under the slogan, "Jackson And No Bank!" True to his word, Jackson succeeds in blocking the renewal of the charter for the Second Bank of the United States.

"Gentlemen! I too have been a close observer of the doings of the Bank of the United States. I have had men watching you for a long time, and am convinced that you have used the funds of the bank to speculate in the breadstuffs of the country. When you won, you divided the profits amongst you, and when you lost, you charged it to the bank. You tell me that if I take the deposits from the bank and annul its charter I shall ruin ten thousand families. That may be true, gentlemen, but that is your sin! If I let you go on, you will ruin fifty thousand families, and that would be my sin! You are a den of vipers and thieves. I have determined to rout you out, and by the Eternal, (bringing his fist down on the table) I will rout you out!" -- Andrew Jackson, shortly before ending the charter of the Second Bank of the United States. From the original minutes of the Philadelphia committee of citizens sent to meet with President Jackson (February 1834), according to Andrew Jackson and the Bank of the United States (1928) by Stan V. Henkels

Shortly after President Jackson (the only American President to actually pay off the National Debt) ended the Second Bank of the United States, there was an attempted assassination which failed when both pistols used by the assassin, Richard Lawrence, failed to fire. Lawrence later said that with Jackson dead, "Money would be more plenty".

Of course, the present day American public school system is as subservient to the bankers' wishes to keep certain items of history from you, just as the corporate media is subservient to Monsanto's wishes to keep the dangers of Genetically Modified foodstuffs from you, and the Global Warming cult's wishes to conceal from you the fact that the Earth has actually been cooling for the last 16 years. Thus it should come as little surprise, that much of the real reasons for the events of the Civil War are not well known to the average American.

When the Confederacy seceded from the United States, the bankers once again saw the opportunity for a rich harvest of debt, and offered to fund Lincoln's efforts to bring the south back into the union, but at 30% interest. Lincoln remarked that he would not free the black man by enslaving the white man to the bankers and using his authority as President, he issued a new government currency, the "greenback". This was a direct threat to the wealth and power of the central bankers, who responded quickly.

"If this mischievous financial policy, which has its origin in North America, becomes entrenched, then that Government will issue it's own money without cost. It will pay off debts and be without debt. It will have all the money necessary to carry on it's commerce. It will become prosperous to a degree which is without precedent in the history of the world. The brains, and wealth of all countries will migrate to North America. That country must be destroyed or it will destroy every monarchy on the globe". -- The London Times responding to Lincoln's decision to issue government Greenbacks to finance the Civil War, rather than agree to private banker's loans at 30% interest.

In 1872 New York bankers sent a letter to every bank in the United States, urging them to fund any newspapers which opposed government-issued money (Lincoln's greenbacks): *"Dear Sir: It is advisable to do all in your power to sustain such prominent daily and weekly newspapers... as will oppose the issuing of greenback paper money, and that you also withhold patronage or favours from all applicants who are not willing to oppose the Government issue of money. Let the Government issue the coin and the banks issue the paper money of the country...To restore to circulation the Government issue of money, will be to provide the people with money, and will therefore seriously affect your individual profit as bankers and lenders".* -- Triumphant plutocracy; the story of American public life from 1870 to 1920, by Lynn Wheeler

"It will not do to allow the greenback, as it is called, to circulate as money any length of time, as we cannot control that". -- Triumphant plutocracy; the story of American public life from 1870 to 1920, by Lynn Wheeler

"Slavery is likely to be abolished by the war, power, and chattel slavery destroyed. This, I and my European friends are in favour of, for slavery is but the owning of labour and carries with it the care for the labourer, while the European plan, led on by England, is for capital to control labour by controlling the wages. THIS CAN BE

DONE BY CONTROLLING THE MONEY". -- Triumphant plutocracy; the story of American public life from 1870 to 1920, by Lynn Wheeler

Goaded by the private bankers, much of Europe supported the Confederacy against the Union, with the expectation that victory over Lincoln would mean the end of the Greenback. France and Britain considered an outright attack on the United States to aid the confederacy, but were held at bay by Russia, which had just ended the serfdom system and had a state central bank similar to the system the United States had been founded on. Left free of European intervention, the Union won the war, and Lincoln announced his intention to go on issuing greenbacks. Following Lincoln's assassination, the Greenbacks were pulled from circulation and the American people forced to go back to an economy based on bank notes borrowed at interest from the private bankers.

Finally, in 1913, the Private Central Bankers of Europe, in particular the Rothschilds of Great Britain and the Warburgs of Germany, met with their American financial collaborators on Jekyll Island, Georgia to form a new banking cartel with the express purpose of forming the Third Bank of the United States, with the aim of placing complete control of the United States money supply once again under the control of private bankers. Owing to hostility over the previous banks, the name was changed to "The Federal Reserve" system in order to grant the new bank a quasi-governmental image, but in fact it is a privately owned bank, no more "Federal" than Federal Express. Indeed, in 2012, the Federal Reserve successfully rebuffed a Freedom of Information Lawsuit by Bloomberg News on the grounds that as **a private banking corporation** and not actually a part of the government, the Freedom of Information Act did not apply to the operations of the Federal Reserve. The year 1913 proved to be a transformative year for the nation's economy, first with the passage of the 16th "income tax" Amendment and the false claim that it had been ratified.

"I think that if you were to go back and try to find and review the ratification of the 16th Amendment, which was the internal revenue, the income tax, I think that if you went back and examined that carefully, you would find that a sufficient number of States never ratified that Amendment". – U.S. District Court Judge James C. Fox (Sullivan vs United States, 2003).

Later in 1913, apparently unwilling to risk another questionable amendment, Congress passed the Federal Reserve Act over the Christmas holiday, while members of Congress who were opposed to the measure were at home. This was a very underhanded deal, as the Constitution which explicitly grants Congress the authority to issue the public currency, does not authorize it to delegate that authority, and so it should have required a new Amendment to allow Congress to transfer that authority to a private bank. But Congress did pass it, and President Woodrow Wilson signed it (as he had promised the bankers that he would, in exchange for generous campaign contributions). Wilson later regretted that decision, stating: *"I am a most unhappy man. I have unwittingly ruined my country. A great industrial nation is now controlled by its system of credit. We are no longer a government by free opinion, no longer a government by conviction and vote of the majority, but a government by the opinion and duress of a small group of dominant men".* – Woodrow Wilson 1919.

The next year, World War One started, and it is important to remember that prior to the creation of the Federal Reserve, there was no such thing as a world war.

The First World War started between Austria-Hungary and Serbia, but quickly shifted to focus to Germany, whose industrial capacity was seen as an economic threat to Great Britain, who saw the decline of the British Pound as a result of too much emphasis on financial activity to the neglect of agriculture, industrial development, and infrastructure (not unlike the present day United States).

Although pre-war Germany had a private central bank, that bank was heavily restricted, and inflation kept to reasonable levels. Under government control, investment was guaranteed to internal economic development, and Germany was seen as a major power. So, in the media of the day, Germany was portrayed as the prime instigator of World War One, and subsequently, not just defeated, but had its industrial base flattened.

Following the Treaty of Versailles, Germany was ordered to pay the war costs of all of the participating nations, even though Germany had not actually started the war. This amounted to three times the value of all of Germany itself. Germany's private central bank, to whom Germany had gone deeply into debt to pay the costs of the war, broke free of government control, and massive inflation followed (mostly triggered by currency speculators), permanently trapping the German people in endless debt.

When the Weimar Republic collapsed economically, it opened the door for the National Socialists to take power. Their first financial move was to issue their own state currency which was not borrowed from private central bankers. Freed from having to pay interest on the money in circulation, Germany blossomed and quickly began to rebuild its industry. The media called it "The German Miracle". TIME magazine lionized Hitler for the amazing improvement in life for the German people and the explosion of German industry, and even named him TIME Magazine's "Man Of The Year" in 1938.

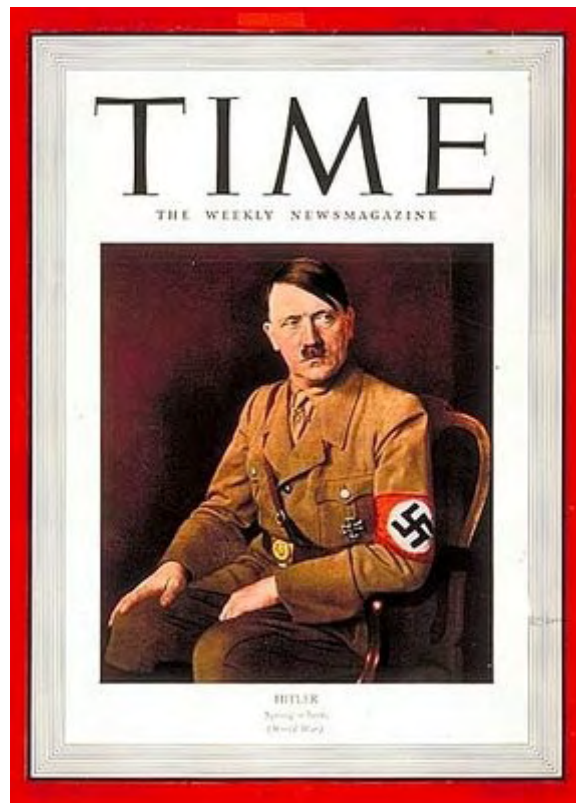

Once again, Germany's industrial output became a threat to Great Britain, resulting in these comments:

"Should Germany merchandise (do business) again in the next 50 years, we have led this war (WW1) in vain". - Winston Churchill in The Times (1919)

"We will force this war upon Hitler, if he wants it or not". - Winston Churchill (1936 broadcast)

"Germany becomes too powerful. We have to crush it". - Winston Churchill (November 1936 speaking to US - General Robert E. Wood).

"This war is an English war and its goal is the destruction of Germany". - Winston Churchill (- Autumn 1939 broadcast) .

Germany's state-issued value-based currency was also a direct threat to the wealth and power of the private central banks, and as early as 1933 they started to organise a global boycott against Germany to strangle this upstart ruler who thought he could break free of private central bankers!

BUY BRITISH **balito** STOCKINGS

Daily Express

Today's Weather: Fair Mild.

NO. 10,258.

FRIDAY, MARCH 24, 1933.



LVEL
CHEESE
Aids digestion
2d., 6d. & 8d. each.
Solely & Exclusively in the Home Counties
(Manufactured in the Home Counties)

JUDEA DECLARES WAR ON GERMANY

Jews Of All The World Unite In Action

BOYCOTT OF GERMAN GOODS MASS DEMONSTRATIONS IN MANY DISTRICTS DRAMATIC ACTION

"Daily Express" Special Political Correspondent.
ALL Israel is uniting in wrath against the Nazi onslaught on the Jews in Germany.
Adolf Hitler, swept into power by an appeal to elemental patriotism, is making history of a kind he least expected. Thinking to unite only the German nation to race consciousness, he has roused the whole Jewish people to a national renaissance. The appearance of the synagoga symbol of a new Germany has called forth the Lion of Judah, the old battle symbol of Jewish defiance.
Fourteen million Jews dispersed throughout the world have banded together as one man to declare war on the German persecutors of their co-religionists. Sectional differences and antagonisms have been submerged in one common aim—to stand by the 600,000 Jews of Germany who are terrorised by Hitlerist anti-semitism, and to compel Fascist Germany to end its campaign of violence and suppression directed against its Jewish minority.
World Jewry has made up its mind not to rest quiet in face of this revival of medieval Jew-baiting.

511,333 a minute to £1,000,000 a minute.
This is the record of the public's thirst for sound investments with a warlike tinge.
When the West Riding County Council issued £1,000,000 of 3½ per cent. stock at 120 per cent. last week they obtained 511,000,000 in fifteen minutes.
Yesterday Middlesbrough asked the public to subscribe to £200,000 of the 3½ per cent. stock, and raised the price to 105 10s. per cent.
The lists were closed in five minutes, during which time applications had been received for £20,000,000.

HIGHER WAGES FOR STEEL WORKERS
AN INCREASE OF THREE SHILLINGS A WEEK
BRIGHT SPOT IN A BLACK TOWN

THE BIRTH OF AN IDEA

DENNIS GLENNE, the young British dress designer, finds inspiration for his fashions by observing living models. Every man to his own trade!

THE "Daily Express" has sent a special representative on an unusual mission. He is touring the north in search of high wages. In his tour he is going to tell the facts about all classes of wages, high and low. He is going to show how low wages reduce the morale of the community. He is going to show how courageous spending means favourably throughout the community. In his first dispatch it is revealed that the steel masters of Middlesbrough have been able to make a feature in the cause of high wages.
Filters in steel works have recently received an increase of 3s. a week. Their wages are not high, but this is a step in the right direction. It is a bright spot in an otherwise black town—brought low by wage cuts and false economy.

New "Sweep" Bill In The Dail
MR. DE VALERA AND STATE CONTROL
SECRET MEASURE

"Daily Express" Special Correspondent.
DUBLIN, Thursday.
The official announcement of the Irish sweepstake draw, was dividing the remnants of the latest Irish lottery prize fund between lucky ticket-holders in the Plaza Ballroom today. I was fortunate to an Under-Secretary of the Free State Government introducing a Bill which may change the whole future, scope, and purpose of these Irish hospital lotteries.
NO CLUE
A mysterious measure entitled "The Public Hospitals Bill, 1933," appeared on the agenda for this afternoon's meeting of the Dail.
The Bill was set down for formal introduction, and a motion to have effect was moved in a six or seven words speech by Mr. Sean O'Kelly, the Minister of Local Government. His brief remarks gave no clue to the

MR. MacDONALD EXPLAINS HIS TOUR
"PEACE CAN BE KEPT IN EUROPE"

MR. RAMSAY MACDONALD faced a crowded House of Commons yesterday afternoon when he spoke about his visits to Paris, Geneva, and Rome, and his talks with Signor Mussolini.
The German, French, Italian, Polish, and Belgian Ambassadors were among a crowd of diplomatic representatives in their special gallery, and Mr. Bruce of Australia, and other representatives of the Dominions also present.
Mr. MacDONALD, who was greeted with cheers, said—
"I take the earliest available opportunity to inform the House regarding what happened while the Foreign Secretary and myself were at Geneva and Rome."
"We were asked for our opinions here to go to Geneva, first because every newspaper showed that there was a grave danger of an indefinite extension of the disarmament conference, and we felt strongly that it might be possible to bring about such a collapse, because we were well and all realised that it was necessary that it should take place."
"Therefore, the Foreign Secretary and I went to Geneva. Our first business was to discuss how matters stood, and for that purpose we interviewed for some two or three days the leading delegates from various nations."
"It is perfectly plain that the conference work had proceeded for some time."
"Mr. MacDonald, the Foreign Secretary and I went to Geneva. Our first business was to discuss how matters stood, and for that purpose we interviewed for some two or three days the leading delegates from various nations."
"It is perfectly plain that the conference work had proceeded for some time."
"Mr. MacDonald, the Foreign Secretary and I went to Geneva. Our first business was to discuss how matters stood, and for that purpose we interviewed for some two or three days the leading delegates from various nations."
"It is perfectly plain that the conference work had proceeded for some time."



LABOUR LEADER BEREAVED
Mr. MacDonald, M.P., Minister of Local Government, died last night.

OFFICER'S DAYS OF LOVE

CUTS THAT KILL

As had been the case in World War One, Great Britain and other nations threatened by Germany's economic power looked for an excuse to go to war, and as public anger in Germany grew over the boycott, Hitler foolishly gave them that excuse. Years later, in a spirit of candour, the real reasons for that war were made clear:

"The war wasn't only about abolishing fascism, but to conquer sales markets. We could have, if we had intended to, prevented this war from breaking out without firing one shot, but we didn't want to".- Winston Churchill to Truman (Fultun, USA March 1946).

"Germany's unforgivable crime before WW2 was its attempt to loosen its economy out of the world trade system and to build up an independent exchange system from which the world-finance couldn't profit any more. ...We butchered the wrong pig". - Winston Churchill (The Second World War - Bern, 1960).

As a side note, we need to step back before WW2 and recall Marine Major General Smedley Butler. In 1933, Wall Street bankers and financiers had bankrolled the successful coups by both Hitler and Mussolini. Brown Brothers Harriman in New York was financing Hitler right up to the day war was declared with Germany. And they decided that a fascist dictatorship in the United States based on the one on Italy would be far better for their business interests than Roosevelt's "New Deal" which threatened massive wealth re-distribution to recapitalise the working and middle class of America. So the Wall Street tycoons recruited General Butler to lead the overthrow of the US Government and install a "Secretary of General Affairs" who would be answerable to Wall Street and not the people, would crush social unrest and shut down all labour unions.

General Butler pretended to go along with the scheme but then exposed the plot to Congress. Congress, then as now in the pocket of the Wall Street bankers, refused to act. When Roosevelt learned of the planned coup he demanded the arrest of the plotters, but the plotters simply reminded Roosevelt that if any one of them were sent to prison, their friends on Wall Street would deliberately collapse the still-fragile economy and blame Roosevelt for it. Roosevelt was thus unable to act until the start of WW2, at which time he prosecuted many of the plotters under the Trading With The Enemy Act. The Congressional minutes into the coup were finally released in 1967 and became the inspiration for the movie, "Seven Days in May" but with the true financial villains erased from the script.

"I spent 33 years and four months in active military service as a member of our country's most agile military force - the Marine Corps. I served in all commissioned ranks from second lieutenant to Major General. During that

period I spent more of my time being a high-class muscle man for Big Business, for Wall Street and for the bankers. In short, I was a racketeer, a gangster for capitalism. I suspected that I was just a part of a racket at the time. Now I am sure of it. Like all members of the military profession I never had an original thought until I left the service. My mental faculties remained in suspended animation while I obeyed the orders of the higher-ups. This is typical with everyone in the military service. Thus I helped make Mexico and especially Tampico safe for American oil interests in 1914. I helped make Haiti and Cuba a decent place for the National City Bank boys to collect revenues in. I helped in the raping of half a dozen Central American republics for the benefit of Wall Street. The record of racketeering is long. I helped purify Nicaragua for the international banking house of Brown Brothers in 1909-12. I brought light to the Dominican Republic for American sugar interests in 1916. In China in 1927 I helped see to it that Standard Oil went on its way unmolested. During those years, I had, as the boys in the back room would say, a swell racket. I was rewarded with honours, medals and promotion. Looking back on it, I feel I might have given Al Capone a few hints. The best he could do was to operate his racket in three city districts. I operated on three continents". -- General Smedley Butler, former US Marine Corps Commandant, 1935

As President, John F. Kennedy understood the predatory nature of private central banking, he understood why Andrew Jackson fought so hard to end the Second Bank of the United States. So Kennedy wrote and signed Executive Order 11110 which ordered the US Treasury to issue a new public currency, the United States Note.



Kennedy's United States Notes were not borrowed from the Federal Reserve but created by the US Government and backed by the silver stockpiles held by the US Government. It represented a return to the system of economics on which the United States had been founded, and this was perfectly legal for Kennedy to do. All told, some four and a half billion dollars went into public circulation, eroding interest payments to the Federal Reserve and loosening their control over the nation. Five months later John F. Kennedy was assassinated in Dallas Texas, and the United States Notes pulled from circulation and destroyed (except for samples held by collectors). John J. McCloy, President of the Chase Manhattan Bank, and President of the World Bank, was named as part of the Warren Commission, presumably to make certain that the banking dimensions behind the assassination were concealed from the public.

As we enter the eleventh year of what future history will most certainly describe as World War Three, we need to examine the financial dimensions behind the wars.

Towards the end of World War Two, when it became obvious that the allies were going to win and dictate the post war environment, the major world economic powers met at Bretton Woods, a luxury resort in New Hampshire in July 1944, and hammered out the Bretton Woods agreement for international finance. The British Pound lost its position as the global trade and reserve currency and its place was taken by the US dollar (part of the price demanded by Roosevelt in exchange for the US entry into the war). Without the economic advantages of being the world's central currency, Britain was forced to nationalise the Bank of England in 1946. The Bretton Woods agreement, was ratified in 1945, and in addition to making the US dollar the global reserve and trade currency, obliged the signatory nations to tie their currencies to the dollar. The nations which ratified Bretton Woods did so on two conditions. The first was that the Federal Reserve would refrain from over-printing the dollar as a means to loot real products and produce from other nations in exchange for ink and paper; basically an imperial tax. That assurance was backed up by the second requirement, which was that the US dollar would always be convertible to gold at \$35 per ounce.

Of course, the Federal Reserve, being a private bank and not answerable to the US Government, did start overprinting paper dollars, and much of the perceived prosperity of the 1950s and 1960s was the result of foreign nations' obligations to accept the paper notes as being worth gold at the rate of \$35 an ounce. Then in 1970, France looked at the huge pile of paper notes sitting in their vaults, for which real French products like wine and cheese had been traded, and notified the United States government that they would exercise their option under Bretton Woods to return the paper notes for gold at the \$35 per ounce exchange rate. Of course, the United

States had nowhere near the gold to redeem the paper notes, so on August 15th, 1971, Richard Nixon "temporarily" suspended the gold convertibility of the US Federal Reserve Notes.

This "Nixon shock" effectively ended Bretton Woods and many global currencies started to disengage from the US dollar. Worse still, since the United States had collateralised their loans with the nation's gold reserves, it quickly became apparent that the US Government did not in fact have enough gold to cover the outstanding debts. Foreign nations began to get very nervous about their loans to the US and understandably were reluctant to lend any additional money to the United States without some form of collateral. So Richard Nixon started the environmental movement, with the EPA and its various programs such as "wilderness zones", "Road-less areas", "Heritage rivers", "Wetlands", all of which took vast areas of public lands and made them off limits to the American people who were technically the owners of those lands. But Nixon had little concern for the environment and the real purpose of this land grab under the guise of the environment was to pledge those pristine lands and their vast mineral resources as collateral on the national debt. The plethora of different programs was simply to conceal the true scale of how much American land was being pledged to foreign lenders as collateral on the government's debts; eventually almost 25% of the nation itself.



With open lands for collateral already in short supply, the US Government embarked on a new program to shore up sagging international demand for the dollar. The United States approached the world's oil producing nations, mostly in the Middle East, and offered them a deal. In exchange for only selling their oil for dollars, the United States would guarantee the military safety of those oil-rich nations. The oil rich nations would agree to spend and invest their US paper dollars inside the United States, in particular in US Treasury Bonds, redeemable through future generations of US taxpayers. The concept was labelled the "petrodollar". In effect, the US, no longer able to back the dollar with gold, was now backing it with oil. Other peoples' oil, and the necessity to keep control over those oil nations in order to prop up the dollar has shaped America's foreign policy in the region ever since.

But as America's manufacturing and agriculture has declined, the oil producing nations faced a dilemma. Those piles of US Federal Reserve notes were not able to purchase much from the United States because the United States had little (other than real estate) which anyone wanted to buy. Europe's cars and aircraft were superior and less costly, while experiments with GMO food crops led to nations refusing to buy US food exports. Israel's constant belligerence against its neighbours caused them to wonder if the US could actually keep their end of the petrodollar arrangement. Oil-producing nations started to talk of selling their oil for whatever currency the purchasers chose to use. Iraq, already hostile to the United States following Desert Storm, demanded the right to sell their oil for Euros in 2000 and in 2002, the United Nations agreed to allow it under the "Oil for food" program instituted following Desert Storm. One year later the United States re-invaded Iraq, lynched Saddam Hussein, and placed Iraq's oil back on the world market only for US dollars.

Following 9-11, the clear US policy shift away from being an impartial broker of peace in the Middle East to one of unquestioned support for Israel's aggressions, only further eroded confidence in the Petrodollar deal and even more oil-producing nations started openly talking of oil trade for other global currencies.

Over in Libya, Muammar Gaddafi had instituted a state-owned central bank and a value-based trade currency, the Gold Dinar. Gaddafi announced that Libya's oil was for sale, but only for the Gold Dinar. Other African nations, seeing the rise of the Gold Dinar and the Euro, even as the US dollar continued its inflation-driven decline, flocked to the new Libyan currency for trade. This move had the potential to seriously undermine the global hegemony of the dollar. French President Nicolas Sarkozy reportedly went so far as to call Libya a "threat" to the financial security of the world.

So, the United States invaded Libya, brutally murdered Gaddafi (the object lesson of Saddam's lynching not being enough of a message, apparently), imposed a private central bank, and returned Libya's oil output to dollars only. The gold that was to have been made into the Gold Dinars is, as of last report, unaccounted for.

According to General Wesley Clark, the master plan for the "dollarification" of the world's oil nations included seven targets, Iraq, Syria, Lebanon, Libya, Somalia, Sudan, and Iran (Venezuela, which dared to sell their oil to China for the Yuan, is a late addition). What is notable about the original seven nations originally targeted by the US is that none of them are members of the Bank for International Settlements, the private central bankers private

central bank, located in Switzerland. This meant that these nations were deciding for themselves how to run their nations' economies, rather than submit to the international private banks.

Now the gun sights of the bankers are on Iran, which dares to have a government central bank and sell their oil for whatever currency they choose. The war agenda is, as always, to force Iran's oil to be sold only for dollars and to force them to accept a privately owned central bank.

The German government recently asked for the return of some of their gold bullion from the Bank of France and the New York Federal Reserve. France has said it will take 5 years to return Germany's gold. The United States has said they will need 8 years to return Germany's gold. This suggests strongly that the Bank of France and the NY Federal Reserve have used the deposited gold for other purposes, and they are scrambling to find new gold to cover the shortfall and prevent a gold run. So it is inevitable that suddenly France invades Mali, ostensibly to combat Al Qaeda, with the US joining in. Mali just happens to be one of the world's largest gold producers with gold accounting for 80% of Mali exports. War for the bankers does not get more obvious than that!

Americans have been raised by a public school system and media that constantly assures them that the reasons for all these wars and assassinations are many and varied. The US claims to bring democracy to the conquered lands (they haven't; the usual result of a US overthrow is the imposition of a dictatorship, such as the 1953 CIA overthrow of Iran's democratically elected government of Mohammad Mosaddegh and the imposition of the Shah, or the 1973 CIA overthrow of Chile's democratically elected government of President Salvador Allende, and the imposition of Augusto Pinochet), or to save a people from a cruel oppressor, revenge for 9-11, or that tired worn-out catch all excuse for invasion: "weapons of mass destruction". Assassinations are always passed off as "crazed lone nuts" to obscure the real agenda.

The real agenda is simple. It is enslavement of the people by the creation of a false sense of obligation. That obligation is false because the Private Central Banking system, by design, always creates more debt than money with which to pay that debt. Private Central Banking is not science, it is a religion; a set of arbitrary rules created to benefit the priesthood, meaning the owners of the Private Central Bank. The fraud persists, with often lethal results, because the people are tricked into believing that this is the way life is supposed to be and no alternative exists or should be dreamt of. The same was true of two earlier systems of enslavement, 'Rule by Divine Right' and 'Slavery', both of which are systems designed to trick people into obedience, and both of which are now recognised by modern civilization as illegitimate. Now we are entering a time in human history where we will recognise that 'rule by debt', or rule by Private Central Bankers issuing the public currency as a loan at interest, is equally illegitimate. It only works as long as people allow themselves to believe that this is the way life is supposed to be.



But understand this above all else, Private Central Banks do not exist to serve the people, the community, or the nation. Private Central Banks exist to serve their owners, to make them rich beyond the dreams of Midas and all for the cost of ink, paper, and the right bribe to the right official.

Behind all these wars, all these assassinations, the hundred million horrible deaths from all the wars lies a single policy of dictatorship. The private central bankers allow rulers to rule only on the condition that the people of a nation remain enslaved to the private central banks. Failing that, any ruler will be killed, and their nation invaded by those other nations which are already enslaved to private central banks.

The so-called "clash of civilizations" we read about on the corporate media is really a war between banking systems, with the private central bankers forcing themselves on to the rest of the world, no matter how many millions must die for it. Indeed the constant hatemongering against Muslims lies in a simple fact. Like the ancient Christians (prior to the Knights Templar's private banking system), Muslims forbid usury (the lending of money at interest), and that is the reason why the American government and media insist that Muslims must be killed or converted. They refuse to submit to currencies issued at interest. They refuse to be debt slaves. So off to war American children must go, to spill their blood for the gold of the money-junkies. We barely survived the last two world wars. In the nuclear/bio weapon age, are the private central bankers willing to risk incinerating the whole planet just to feed their greed? Apparently so.

Flag waving and propaganda aside, all modern wars are wars by and for the private bankers, fought and bled for by third parties unaware of the true reason why they are expected to be killed and crippled. The process is quite simple. As soon as the Private Central Bank issues its currency as a loan at interest, the public is forced deeper and deeper into debt. When the people are reluctant to borrow any more, that is when the Keynesian economists demand the government borrow more to keep the pyramid scheme working. When both the people and government refuse to borrow any more, that is when wars are started, to plunge everyone even deeper into debt to pay for the war, then after the war to borrow more to rebuild. When the war is over, the people have about the same as they did before the war, except the graveyards are far larger and everyone is in debt to the private bankers for the next century. This is why Brown Brothers Harriman in New York was funding the rise of Adolf Hitler.

As long as Private Central Banks are allowed to exist, inevitably, as night follows day, there will be poverty, hopelessness, and millions of deaths in endless World Wars, until the Earth itself is sacrificed in flames to Mammon. The path to true peace on Earth lies in the abolishment of all private central banking everywhere, and a return to the state-issued value-based currencies that allow nations and people to become prosperous.

Michael Rivero

The Economic Hit-Men

It is one of the most ingenious scams for social manipulation ever invented, and at its core, it is an invisible war waged against the population, and you will remember that the Emergency Banking Relief Act of 9th March 1933, **defined** the American people as “the **enemy**” of the United States Government. Debt is the weapon used to conquer and enslave societies and interest is its prime ammunition. While the majority of people are not aware of this reality, banks in collusion with governments and corporations continue to expand and perfect their tactics of economic warfare, spawning new bases such as the World Bank and the International Monetary Fund and introducing a new kind of soldier - the economic hit-man.

Here is the testimony of one of those American economic hit-men, John Perkins:



We, the economic hit men, are the ones really responsible for creating the first really global empire, and we work many different ways. Perhaps the most common is that we will identify a country which has resources which our corporations covet, such as oil, and then arrange a huge loan to that country from the World Bank or one of its sister organisations. But the money never actually goes to the country, instead, it goes to our big construction corporations to build infrastructure projects in that country, like industrial power plants, things which benefit a few rich people in that country (in addition to our corporations), but really don't help the people involved, however those people and the whole country are left holding a huge debt so big that they can't repay it, which is the whole plan - that they can't repay it. So we economic hit men go back to them and say “listen, you owe us a lot of money, you can't repay it, so sell your oil real cheap to our oil companies, allow us to build a military base in your country or send troops to some place in the world to support our troops in somewhere like Iraq, or vote with us in the UN to have their electric utility company privatised, or their sewage system privatised and sold to US corporations or other multinational corporations, so there is a whole mushrooming thing and it's the way that the World Bank and the International Monetary Fund operate to put a whole country in debt with such a big debt that it can't pay it, so you then offer to refinance that debt and get them to pay even more interest and you demand this

'quid pro quo' or 'conditionality' or 'good governance' which means basically that they have to sell off their resources, including their social services and utility companies, their school systems sometimes, their penal systems, their insurance systems to foreign corporations. So, it's a double, triple, quadruple whammy.

Examples:



Iran 1953: The precedent for economic hit men began back in the early 1950s when the democratically elected Prime Minister of Iran, Dr Mohammed Mossadegh, was considered to be a hope for democracy - Time Magazine's Man of the Year. One of the policies which he ran on was the idea that the oil companies needed to pay the Iranian people a lot more for the oil which they were taking out of Iran. We didn't like that, of course, but we were afraid to do what we would normally do, which is to send in the military. Instead, we sent in one CIA agent, a relative of President Roosevelt. He went in with a few million dollars and was very efficient and effective and in a short amount of time he managed to get Mossadegh overthrown and brought in the Shah of Iran to replace him. It was extremely effective. So back here in the United States, people in Washington looked around and said "wow - that was easy and cheap !" So this established the whole new way of manipulating countries and creating empire. The only problem with Roosevelt was that he was a card-carrying CIA agent and if he had been caught, the ramifications would have been pretty serious. So, very quickly at that point a decision was made to use private 'consultants', to channel the money through the World Bank, the IMF or one of the other such agencies, bring in people like me who worked for private companies, so that if we got caught, there would be no government ramifications.



Guatemala 1954: When Arbenz (Jacobo Arbenz Guzman) became President of Guatemala, the country was very much under the thumb of the United Fruit Company, the big international corporation and Guzman ran under the strategy of giving the land back to the people. When he was elected he started implementing those policies of giving the land back to the people. United Fruit didn't like that so much, so they hired a Public Relations company in the United States mounted a huge campaign to convince the people of the US, the press of the US and the Congress of the US that Arbenz was a Soviet puppet and if we allowed him to stay in power the Soviets would have a foothold in this hemisphere, which, at that time, was a huge fear on everybody's minds, so to make a long story short, out of this public relations campaign came a commitment on the part of the CIA and the military to take this man out, and in fact, we did. We sent in planes, we sent in soldiers, we sent in jackals, we sent in everything

to take him out, and we did take him out. And as soon as he was removed, his successor reinstated the links to the big corporations including United Fruit.



Ecuador 1981: Ecuador for many, many years was ruled by pro-US dictators, often relatively brutal. Then it was decided that they were going to have a truly democratic election Jaime Roldos (Aguilera) ran for office and his main goal, he said, as President was to make sure that Ecuador's resources were used to help the people. And he won, overwhelmingly, by more votes than anyone has ever won anything in Ecuador and he began to implement these policies to make sure that the profits from oil went to help the people. Well, we didn't like that in the United States. I was sent down as one of several economic hit men to change Roldos, to corrupt him, to bring him around, to let him know "you know, you and your family can get very rich if you play our game but if you but if you continue to try and keep these policies you promised, then you are going to go". He wouldn't listen. He was assassinated "Ecuadorian Leader Dies in Plane Crash". As soon as the plane crashed, the whole area was cordoned off. The only people allowed in were the US military from a nearby base and some of the Ecuadorian military. When an investigation was launched, two of the key witnesses died in car accidents before they had a chance to testify. A lot of very, very strange things went on around the assassination of Roldos. I, like most of the people who really looked at this case had absolutely no doubt that it was an assassination and of course, in my position of an economic hit man, I was expecting something to happen to Jaime, whether a coup or an assassination I was sure that he would be taken down as he was not being corrupted, he would not allow himself to be corrupted the way we wanted to corrupt him.



Panama 1981: Omar Torrijos President of Panama was one of my favourite people. I really, really liked him, he was very charismatic and he really wanted to help his country. When I tried to bribe him, to corrupt him, he said "look, John, he called me Juanita, look Juanita, you know, I don't need the money, what I really need is for my country to be treated fairly. I need the United States to repay the debts which you owe my people for all the

destruction you have done here. I need to be in a position to help other Latin American countries with their independence and be free of this terrible presence from the North. You people are exploiting us so badly. I need to have the Panama Canal back in the hands of the Panamanian people. That's what I want. So leave me alone, don't try to bribe me". It was in 1981 and in May Jaime Roldos was assassinated and Omar was very aware of this. He got his family together and said "I'm probably next, but it is ok because I've done what I came here to do, I've renegotiated the Canal, the Canal will now be in our hands". He had been renegotiating the treaty with Jimmy Carter:



In June of that same year, just a couple of months later, he also went down in an aeroplane crash which there is no question was executed by CIA jackals. There is a tremendous amount of evidence, one of Tarrijas' security guards handed him, at the last moment as he was getting on the plane, a small tape recorder which contained a bomb.



Venezuela 2002: It is interesting to me how this system has continued pretty much the same way for years and years and years except the economic hit men get better and better and better. Then we come up with, very recently, what happened in Venezuela in 1998 when (Hugo Rafael) Chavez gets elected, following a long line of Presidents who were very corrupt and who basically destroyed the economy of the country, and Chavez was elected following all of that. Chavez stood up to the United States demanding that Venezuela oil be used to help the Venezuelan people. Well we didn't like that in the United States, so in 2002, a coup was staged, and there is no question in my mind or in most other people's minds, that the CIA was behind that coup. The way that coup was fermented was very effective, like Colonel Roosevelt had done in Iran - paying people to go out into the streets to riot, to protest and say that Chavez is very unpopular. You know, if you can get a few thousand people to do that, television can make it look like the whole country and things start to mushroom, except in the case of Chavez, he was smart enough and the people were so strongly behind him that they overcame it, which was a phenomenal moment in the life of Latin America.



Iraq 2003: Iraq, actually, is a perfect example of the way the whole system works. We economic hit men are the first line of defence. We go in and try to corrupt governments and get them to accept these huge loans which we then use as leverage to basically own them. If we fail, as I failed in Panama with Omar Tarrijas, and in Ecuador with Jaime Roldos, men who refused to be corrupted, then the second line of defence is we send in the jackals and the jackals either overthrow governments or they assassinate and when that happens and a new government comes in, boy, it's going to toe the line as the new President knows what will happen if he doesn't. And in the case of Iraq, both of those things failed and the economic hit men were not able to get through to Saddam Hussein although they tried very hard. We tried very hard to get him to accept a deal but he wouldn't accept it and so the jackals went in to take him out but they couldn't do it as his security was very good. After all, he had at one time worked for the CIA and been hired to assassinate a former President of Iraq and failed, but he knew the system. So, in 1991 we send in the troops and we take out the Iraqi military, assuming that at that point that Saddam is going to come around. We could, of course, have taken him out at that time, but we didn't want to as he is the kind of strong man that we like, able to control his people and keep pumping oil for us. But when we took out his military he didn't come around so the economic hit men go back in the 90s without success. If they had had success, he'd still be running the country - we'd be selling him all the fighter jets he'd want, but they didn't have success. The jackals couldn't take him out again, so we sent the military in once again and took him out, and created for ourselves very lucrative reconstruction deals to rebuild a country which we had essentially destroyed - which is a very good deal if you own a construction company - a really big one. So, Iraq shows the three stages: the economic hit men - failed there, the jackals failed there, so as the final measure, the military goes in.

And in that way, we have really created an empire, but we have done it very, very subtly, it's clandestine. All the empires in the past were built by the military and everybody knew they were building them. The British knew they were building it, the French, the Germans, the Romans, the Greeks - they were all proud of it and they always had some excuse like "spreading civilisation", or spreading some religion, something like that, but they knew they were doing it. We don't. The majority of the people in the United States have no idea that we are living off the benefits of a clandestine empire, that today there is more slavery in the world than ever before.

You may have to ask yourself if it's an empire, then who's the Emperor? Obviously, our Presidents in the United States are not Emperors. An Emperor is someone who is not elected, does not serve a limited term, and who doesn't report to anyone. So you can't classify Presidents that way. But we do have what I consider to be the equivalent of the Emperor in what I call the "Corporatocracy". The Corporatocracy is this group of individuals who run our biggest corporations and they really act as the Emperor of this empire. They control our media (either by direct ownership or by advertising), they control most of our politicians because they finance their campaigns, either through corporations or through personal donations. They are not elected, they don't serve a limited term, they don't report to anybody, and at the very top of the Corporatocracy, we can't tell if the person is working for a corporation or for the government as they are always moving back and forth, so you get a guy who is one moment the president of a big company like Halliburton and the next moment he's the Vice President of the United States, or the President who is in the oil business and this is true whether you get Democrats or Republicans in the office, you have them moving back and forth through the revolving door, and in a way, our government is invisible a lot of the time as it's policies are carried out by a corporation on one level or another, and then again, the policies of the government are basically forged by the Corporatocracy and then presented to the government and become government policies. So, it is an incredibly cosy relationship. This isn't a "conspiracy theory" kind of thing, these people don't have to get together and plot to do things, they all basically work under one primary assumption, and that is that they must maximise profits regardless of the social and environmental costs.

This process of manipulation by the Corporatocracy, through the use of debt, bribery and political overthrow, is called "Globalisation". Just as the Federal Reserve keeps the American people in a position of indentured

servitude, through perpetual debt, inflation and interest, the World Bank and International Monetary Fund fulfil this role on a global scale.

Oh, and by the way, the lame excuse for going to war with Iraq which was never believable beforehand, is laid out in fair detail here by a high-ranking US Major General expert in gathering and interpreting military and terrorist intelligence: http://www.youtube.com/watch?v=W0xzsbSbVUE&feature=player_embedded.



Libya 2011: If the ruler of a country refuses to become the servant of the New World Order people, he is subjected to character assassination and physically attacked with troops. I don't for a moment suggest that Col. Gaddafi was a saint, but as the Bible so aptly remarks, you can tell a man's character by the things which he does, so what did Col. Gaddafi do? Well, here is some information passed to me and I leave you to decide for yourself:

1. In Libya, electricity is free for all of its citizens.
2. There is no interest on loans, banks in Libya are state-owned and loans are given to all its citizens at 0% interest which is requirement of Libyan law.
3. Owning a home is considered a human right in Libya – Gaddafi vowed that his parents would not get a house until everyone else in Libya had a home. Gaddafi's father has died while he, his wife and his mother were still living in a tent.
4. All newlyweds in Libya receive \$60,000 Dinar (US\$50,000) from the government, to buy their first apartment to help them start a family.
5. Education and medical treatments are free in Libya. Before Gaddafi only 25% of Libyans were literate. Today the figure is 83%.
6. If any Libyan wants to take up farming, he receives farming land, a farm house, equipment, seeds and livestock to kick- start their farms – all for free.
7. If Libyans cannot find the education or medical facilities they need in Libya, the government funds them to go abroad for it – not just free, but they get US\$2, 300 per month for accommodation and running a car.
8. If a Libyan buys a car, the government pays 50% of the price.
9. The price of petrol in Libya is US\$0.14 per litre (in the UK, it is \$2.17 per litre at this time, which is more than 15 times as much).
10. Libya has no external debt and its reserves amount to US\$150 billion – now frozen globally.
11. If a Libyan is unable to get employment after graduation, the state pays the average salary of the profession as if he or she is employed, until employment is found.
12. A portion of Libyan oil sale revenues is credited directly to the bank accounts of all Libyan citizens.
13. A mother who gives birth to a child receives US\$5 ,000.

14. 40 loaves of bread in Libya costs just US\$ 0.15 (in the UK, it is 200 times more expensive).
15. 25% of Libyans have a university degree, while in the UK, Sir Clive Woodhead, former Chief Inspector of Schools, has recently recommended that children should leave school at age 14 and become apprentices.
16. Col. Gaddafi carried out the world's largest irrigation project, known as the Great Man-Made River project, to make water readily available throughout his desert country.

So, I will leave it up to you to decide if the attacks on Libya and the killing of Col. Gaddafi was an honest action designed to make the world a safer and better place, or if those actions were motivated by some other agenda.

The Technique:

The lawyers and bankers have the objective of taking all of your money and keeping you permanently in debt to them. In the UK, the currency was "the pound sterling" and a £1 note was a promise certifying that there was literally a one pound weight of sterling silver held in storage to back the value of that note and save the person carrying around the actual pound weight of silver.

That link was broken, and nowadays, the £1 note (or in the US, the \$1 note) has no actual value as it is no longer a promise that an amount of valuable metal is being held in storage in order to give that piece of paper its value. In reality, these paper currency notes have no more value than the paper notes in the board game "Monopoly" and that value is only the value of the paper on which the notes are physically printed, which is, almost nothing at all.

Take the process in America as an example: The "government" decides that it needs some money, so it calls up the (privately owned) Federal Reserve Bank and requests, say, \$10,000,000,000. The Federal Reserve Bank replies saying "Sure, we will buy \$10 billion in government Bonds from you". So the "government" takes some pieces of paper, paints some official-looking designs on them and calls them "Treasury Bonds". Then it puts a value on them of \$10 billion and sends them over to the Federal Reserve Bank. In turn, the people in the Federal Reserve Bank draw up a series of impressive looking pieces of paper themselves, only, this time, calling them Federal Reserve notes, also designated with a value of \$10 billion. The Federal Reserve Bank then takes these notes and trades them for the Treasury Bonds. Once this trade is complete, the government then takes the \$10 billion in Federal Reserve notes and deposits them in a bank account, and on doing this, the \$10 billion becomes legal tender money, adding \$10 billion to the US money supply. And there it is: \$10 billion in new money has been created out of nothing and with no intrinsic value whatsoever. Of course, this example is a generalisation because in reality, this transaction would occur electronically, with no paper used at all. In fact, only 3% of the US money supply exists in physical currency and the other 97% exists in computers alone.

The same style of operation happens in the UK as well with the (privately owned) Bank of England, producing valueless 'currency'. The banks deliberately compound the problem by lending this valueless money to individual people as a loan or mortgage, knowing full well that there is not enough money in circulation to pay off the loan and the interest. If, for example, the loan is £1000 on a credit card, then the credit card company will want about £1200 back as they charge interest. But as they do that with all of the "money" fraudulently created (actually ten times the amount in America), there is physically not enough to allow the interest to be paid unless the economy of the country keeps on expanding rapidly. The objective here is to take physical goods and possessions away from the borrower when he finds himself unable to pay the amount asked for.

The total lack of value of present day currency was demonstrated when a mortgage loan repossession was challenged in court in America. For any commercial contract anywhere in the world to be valid, something of worth has to be put forward by both parties to that contract. When a bank "lends" its worthless money as a mortgage, it has put forward nothing of value and so the mortgage contract is not valid in law.

In 1969, there was a Minnesota court case involving a man named Jerome Daly who was challenging the foreclosure of his home by the bank which provided the loan to purchase it. His argument was that the mortgage contract required both parties (himself and the bank) to put up a legitimate form of property for the exchange. In legal language, this is called a "consideration" from both parties. Mr Daly explained that the money was, in fact, not the property of the bank as it was created out of nothing as soon as the loan agreement was signed. In other words, the money didn't come out of the bank's existing assets as the bank simply invented it, consequently, the bank put up nothing of value of its own, except for a theoretical liability on paper. As the court case progressed, the bank's President, Mr Morgan, took the stand and the judges memorandum records that the "Plaintiff admitted that it, in combination with the Federal Reserve Bank ... did create the entire \$14,000 in money in credit upon its own books by bookkeeping entry ... the money and credit first came into existence when they created it. Mr Morgan admitted that no United States Law or Statute existed which gave him the right to do this. A lawful

consideration must exist and must be tendered to support the Note" ... The jury found that there was no lawful consideration, and on this finding, the court rejected the bank's application for foreclosure and Mr Daly kept his home.

The Consequences:

There does not seem to be much point in commenting on the situation in other countries around the world as you will find the same style of underhand operation in most of them. However, when you understand what is going on, it explains why it has been so difficult to get any free-energy device on to the market for sale to members of the public.

A really major strand of both income and control comes from access to energy. The average person wants energy for heating and cooling a home, running household equipment such as refrigeration, lighting, computing, etc. and for powering a vehicle, operating power tools, and so on. Under the present deceptive regime, we are told from an early age that we need to burn a fuel in order to get this power, and instead of doing it individually, it appears to be cheaper to buy the power from the local energy company.

The reality is that we live in a sea of energy which can supply our every need for ever and ever without the slightest need for burning any kind of fuel. Devices for tapping this energy have been produced by literally thousands of inventive people and yet, they are not for sale. Why do you think that is?

Well, one of the reasons is that inventors of these devices often feel that they should "protect" their invention by patenting it and so they make an application to a Patent Office. Unfortunately, the Patent Office is a commercial business owned by the same people who make massive amounts of money from selling you oil to burn and electricity to use. Because of that, they steal the best of these inventions, often by telling the inventor that his invention is "Of National Security Importance" and so he can't use it, sell it or even speak to other people about it, and if he did, he would be put in prison. That is, of course, an unlawful deception as the people telling him that have nothing whatsoever to do with anything National, except the use of the word in their company name. There certainly is no government around to make any kind of statement like that.

The wonderful people then use your money in unlimited amounts to develop these inventions as secret "black" projects and they have been doing this for at least a hundred years. People who have been employed in some of these projects report that they now have technology anything from 100 to 1,000 years in advance of what the public is told about. Almost everything shown in the fictional "Star Trek" series has already been produced covertly in real life. The internet has made it difficult to keep on hiding these advances, but they fight back by posting false information, contradicting people who present the real deal, and generally disrupting and flooding every useful forum with a combination of rubbish and inflammatory attacks on forum members.

A major strand of the attempt to suppress the truth is through universities and respected Engineering bodies and publications. This is done through financial pressure. To have a successful career, a university professor needs to have regular publication of research papers. For this, he needs researchers who are paid to do the research. This is done through grants from rich people and organisations. Those are the very people who will under no circumstances allow the publication of any research which demonstrates that free-energy exists and they make sure that no funding will ever be available for any such research.

If a scientist steps out of line and goes public with the facts, he is immediately attacked by all of his former colleagues who promptly say that what he says is "impossible" and "breaks the laws of physics", neither of which are actually true. For example, in 2010, Rosemary Ainslie and her colleagues demonstrated under strict laboratory conditions that a pulsed heating element produces 17 times more heat output than could be produced by the tiny electrical input driving the element. This was written up in standard scientific paper format and passed to the Institute of Electrical Engineers for examination and publication. As was expected, the paper was refused in spite of the fact (or perhaps because of the fact) that the laboratory results were conclusive. None of the present scientific institutions will publish any form of free-energy paper as that would not be good for the business of their owners.

If an inventor skips the Patent Office, avoids the scientific journals, and tries to get his invention manufactured, he needs substantial funding and that is usually blocked by the concerted efforts of the groups of companies whose businesses would be harmed by the invention becoming freely available to the public. Some times, the inventor is threatened and intimidated. I personally know several people who have had this done to them, but the most common block is financial. For example, Cal-Tech in America spent a million dollars developing, testing, proving and perfecting a carburettor which gave vastly improved mpg results and which cut pollution to near zero. They teamed up with the very large auto-parts supplier Arvin Meritor to put the carburettor into production vehicles. Then "One Equity Partners" bought out the Arvin Meritor division which did all the final work, and then they created a new company, "EMCON Technologies", which dropped the carburettor from their product line, not

because it did not work but because it did work. Oil sales were the only interest and cutting pollution was seen as irrelevant.

Web Links

If you want to research this fraudulent commercial domination over you, then here are some links which might be helpful:

<http://www.youtube.com/user/ThriveMovement> How To Thrive: A clear and comprehensive explanation of the present situation and what YOU can do about it (very highly recommended).

<http://www.youtube.com/watch?v=AXAnba23qV4> Mortgages are Fake: A recent video demonstration that mortgages are fake and fraudulent.

<http://www.truth-now.net/case1.htm> Australian Fakes: A video demonstrating that Australia has no lawful Courts, Police, Customs, Parliament, etc. from www.truth-now.net

<http://thecrowhouse.com/Documents/mary-book.pdf> Mary Croft's eBook "How I Clobbered Every Bureaucratic Cash-Confiscatory Agency Known to Man"

<http://www.documentarywire.com/john-harris-its-an-illusion> A lecture by John Harris entitled "It's An Illusion"

<http://www.tpuc.co.uk/> John Harris' web site "The People's United Community"

<http://www.zshare.net/audio/5485964026c8ef48> An audio interview with Thomas Anderson – part 1

<http://www.zshare.net/audio/548937360de2ee12> An audio interview with Thomas Anderson – part 2

<http://educate-yourself.org/cn/strawmanillusion02apr10.shtml> The Strawman Illusion Explained

<http://panacea-bocaf.org/honordishonor.htm> Panacea's strawman information web page

<http://video.google.com.au/videoplay?docid=3296715122664269567#> The "Hi-jacking Humanity" video

<http://www.youtube.com/watch?v=YHZTjTmrgjI> Interview with Mary Croft, part 1

<http://www.youtube.com/watch?v=alqgpuAwpzM&NR=1> Interview with Mary Croft, part 2

http://www.youtube.com/watch?v=8hqnaHNw_fo&feature=related Interview with Mary Croft, part 3

<http://www.youtube.com/watch?v=P9zxVMNmJsE&feature=related> Interview with Mary Croft, part 4

<http://www.youtube.com/watch?v=iWnv66ERXiw&feature=related> Interview with Mary Croft, part 5

<http://www.youtube.com/watch?v=BUD5f0MWnKo&feature=related> Interview with Mary Croft, part 6

http://www.archive.org/details/Michael_Badnarik Seven hours of intensive training by Michael Badnarik

<http://web.archive.org/web/20060407062015/http://www.worldnewsstand.net/law/PLAY BALL.htm> The Commerce Game Exposed

<http://famguardian.org/TaxFreedom/Instructions/3.17QuitSocialSecurity.htm> Tax Freedom in America

<http://www.getoutofdebtfree.org/> Get Out of Debt Free website

<http://video.google.com/videoplay?docid=-2550156453790090544#> The "Money As Debt" video

<http://video.google.com/videoplay?docid=-515319560256183936#> "The Money Masters" video

<http://www.thebcgroup.org.uk/video> The British Constitution Group videos

<http://web.archive.org/web/20060206085143/www.worldnewsstand.net/law/REDEMPTION3.htm> The Application of Commercial Law

The Practical Situation

Some of this is quite difficult to absorb and understand, so perhaps a little extra detail may be helpful. Just to recap; there are two separate and totally different systems: the law and the legal system.

The law boils down to “don’t harm anyone or his property, steal his property or swindle him”. That is pretty straightforward and it is binding on everyone. You will notice that it does not say anything about keeping to a speed limit, paying taxes, getting married, serving in an army, voting in an election, or any one of thousands of other things. Those things are not required by the law. The requirements of the law are “don’t harm anyone, damage or steal his property or defraud him”, nothing else.

The legal system is an invention intended to do exactly the opposite, namely, harm you, steal your property, subject you to the will of someone else and to defraud you generally. The operating method is lies and deception and a prolonged attempt to prevent you finding out the facts. Thankfully, being subject to the legal system is optional – completely your own choice. So, by refusing to consent to being subject to it, you can shrug it off and live a life free from it.

One of the really difficult things to understand is finance. For example: Al Baker, decides to set up a finance company, lending money and charging interest on the loans. He registers “The Swindle Finance Company Limited”, which is a paper invention of the legal system and is not actually a real thing at all – just some pieces of paper and a name written into a list of paper companies.

His friend Charles Daly who lives across the street, decides to deposit £10,000 (or dollars, or Euros, or whatever the local currency is called) with Al because Al is offering 10% annual interest on all deposits as a special advertising promotion. Al puts the money in the bank account of Swindle Finance Company Limited and enters the amount as a credit in the company accounts ledger. Big smile – the business is starting to roll in.

Gary Hughes then decides that he could do with a round-the-world holiday cruise and so he asks Al for a loan of £10,000. Al is delighted and is about to lend him the £10,000 which Charles lodged when his financial director, Ed Foyle, says “hey, you can’t do that, there is a (statute) law against it - if Charles suddenly need money for something and wants to withdraw his money, you have to be able to repay him in full, so you are not allowed to lend his money to anyone else”.

Al is a bit stumped by that and asks “how can we lend money then – it seems impossible?”. It’s quite ok says Ed, we just invent the money. Here, get Gary Hughes to sign this form, but make quite sure that the form says “Mr Gary Hughes” or “MR GARY HUGHES” as that is very important. When the form is signed, we can enter it in our company accounts as a credit because his signature makes it a promissory note which has a value of £10,000 for us. Then, we start making real money by writing him a cheque instead of handing him money. He will sign that cheque in order to cash it and that is worth another £10,000 to us. This is great business as we can enter his signed cheque into our ledger as another £10,000 asset, and write the £10,000 which goes into his account as a debit. We have now got £20,000 coming in and only £10,000 going out, so we are already ahead by £10,000 and it isn’t even time for lunch on our first day. Also, if Gary pays back the loan and our 20% interest, then this transaction will have made us a net profit of £22,000. If he didn’t pay us back anything, we would still be £10,000 ahead, so let’s celebrate.

Poor Al is a bit confused, so he asks “but where does the £10,000 that we lend Patrick come from?”. Ed laughs and says, it doesn’t come from anywhere, we just write numbers into our ledger against the name of Mr Gary Hughes – it doesn’t cost us anything – do you think he would hold still long enough for us to stamp “sucker” on his forehead? After all, he is about to pay us more than twice, which means that we will make millions in profit each year. Poor Al is still confused, which is a pity, as Gary is the only person which Ed wants to keep confused about the transaction.

Ed knows all of the legal angles and when he is driving home he exceeds the speed limit. It is not dangerous in any way as there is no other traffic, and the road conditions are perfect. A police car pulls alongside him and indicates that they want him to stop, so he pulls over and stops. A police officer approaches and asks Ed if he is aware that he was driving at 40 mph in a 30 mph zone. Ed says that he was indeed aware of that.

The police officer then asks Ed for his name and address. But, Ed is aware of the fact that this is a fraudulent attempt to get him to agree to “Joinder”, that is, agreeing that he is subject to all legal statutes, giving the police officer authority over him. So, he promptly states that the law does not require him to provide any such information, he also mentions the fact that the law does not require him to drive at, or below, 30 mph in a 30 mph zone. The police officer tries this again several times, getting the same answer each time.

Being a bit stumped by this unexpected response, the police officer switches tactics and says that he may have to take Ed down to the police station for further questioning and asks if Ed understands. Being well up on legal

tactics and realising that asking “do you understand” is a fraudulent attempt to establish Joinder, he calmly states that under the law, he is not required to go to a police station and he does NOT “stand under” the police officer or his statement. He also remarks that if he is taken to a police station unlawfully and against his will and without his consent, then he will take action against the police officer personally as a man and not as a police officer, for his unlawful actions. He also asks the police officer if he is aware that the Police Authority which employs him is not a government agency but is a commercial for-profit company with no powers whatsoever to uphold the law, that the police officer is only empowered to uphold the law through the oath which he personally took when he became a policeman and it has nothing whatsoever to do with any form of authority coming from his employers. In other words, he is on his own on this one.

Ed further points out that under the law, there has to be a victim (who has been injured, has his goods damaged or stolen, or who has been defrauded) and he asks the police officer to identify the victim in this case. He also remarks that legal statutes only have the force of law for those people who consent to be bound by them, and he does NOT consent to be bound by them, and so, driving at 40 mph in a 30 mph zone where nobody was endangered and no harm or damage occurred, is not an offence for him.

I'll leave you to work out the likely outcome of the conversation between Ed and the police officer.

Six months later, Ivan Johnson, a friend of Gary Hughes, remarks that Gary is looking worried and asks him if anything is wrong. Gary, who is self-employed, says that business has been very poor for some time and he is having financial problems. His main difficulty is this loan that he has with the Swindle Finance Company Limited. He has not been able to keep up the payments and he has just has a letter from them saying that he has to pay £2,231.47 by Friday, or they will take him to court. Fortunately, Ivan is familiar with both finance and legal matters, so he tells Gary what to do. His advice is simple, he says; for your contract with the Swindle Finance Company Limited to be valid, it has to meet these requirements:

1. Full disclosure, which didn't happen as they did not tell you that your signature created the credit.
2. Equal Consideration, which didn't happen as they have nothing to lose as they didn't bring anything to the table.
3. Lawful terms and conditions
4. Signatures of the Parties, which didn't happen as companies can't produce a “wet ink” signature.

So, you send them a letter agreeing to pay any financial obligation which you might lawfully owe, as soon as they:

1. Provide validation of the debt, that is, the actual accounting.
2. Verification of their claim against you, that is, a sworn affidavit or a signed Invoice.
3. A copy of the Contract binding both parties.

Sign the Letter “Gary Hughes” (**not** “Mr Gary Hughes”) and write “All Rights Reserved” after your signature. Send the letter by registered delivery so that there is a third-party record of it being delivered to them.

The financial institution can't validate the debt as they never sustained a loss. They can't verify any claim against you as their billing is to “Mr Gary Hughes” or “MR GARY HUGHES” or “Mr G. Hughes” or “Hughes, Mr G” or some such wording, and none of those is you, since you are the man Gary Hughes. They can't produce a copy of the contract, because one doesn't exist – what exists is an unenforceable unilateral contract with no standing in law.

If they send you a statement of account, then tell them that a statement is not an Invoice and that you need an Invoice. If they send you a photocopy of your loan application form, then tell them that it is not a contract, being signed by only one of the parties.

If they delay and delay, then write and tell them that if they do not provide the requested documentation within fourteen days, that you will consider any debt as being fully discharged.

If they are ill-advised enough to attempt to take you to court, send a copy of your letter agreeing to pay provided they produce the evidence that there is something outstanding to pay, to the court. They may well be penalised by the court for wasting court time as courts only adjudicate between parties who disagree and there is no disagreement in your case as you have agreed to pay if the Swindle Finance Company Limited shows you that you are liable to pay them some amount of other.

Having had this explained to him, I will leave it up to you to decide if Gary felt any better about his situation.

The legal system is very large and very complex. This is quite deliberate and it is intended to make sure that no ordinary person knows all of it. Fortunately, the law is much less complicated and if you are very careful not to walk into any of the traps set for you, you can effectively ignore the legal system. If required to sign anything and you decide to do so, then Gary Hughes should sign it “By: Gary Hughes, agent” or “By: Gary Hughes, principal” as that you are not taking on any responsibilities in the strawman's name.

John Harris of the TPUC organisation, has found a very effective technique for dealing with the attempts of the legal people to extract money from you, is to never go to court (remember that a 'Summons' is only an invitation and you can decline it) and returning all correspondence marking it "No Contract – Return to Sender". This avoid you ever walking into a "Joinder" trap and becoming liable for the fraudulent claims being made against your strawman. I suggest that you research this subject further and become completely familiar with your rights under common law, and the fraudulent "Joinder" traps being set for you. What you decide to do after that, is entirely up to you.

The Situation in Australia

It appears that both the government and the legal system of Australia are null and void as the basis on which they were created no longer exists. Sir Harry Gibb has this to say about the situation:

I am a former member of the High Court and I wish to take this unusual method of informing you about a matter that is going to deeply affect us all. Unfortunately, a document such as this is too easily "lost" in the bureaucratic jungle in which we operate.

A group of Australian Citizens have taken it upon themselves to test the validity of our current political and judicial system. Like you, I have lived my entire legal career with the assumption that the basis for our legal and political system, state and federal, was written in stone. This group has undertaken to present this paper where they test the legal system.

The group is articulate, well educated and has some of our best legal minds amongst its members. One of Australia's best known barristers is one of the group's leading lights. It is far better informed with regard to international law than most members of the judiciary or for that matter, the legal academe. It has better international contacts than I would have thought possible.

After spending some time with the group leader, I was able to elicit it's primary intentions. It is the introduction of a totally democratic system of government devoid of party politics operated by the will of the people incorporating a system of debit taxation which should go a long way to eliminating the current unemployment problem and addressing other pressing social issues. An A.B.S. financial model supports the proposal.

The group has so far concentrated on matters relating to taxation, state and federal, minor industrial and motor traffic while undertaking not to present a criminal defence using their current presentation. I challenged the leader of this group to present any evidence which he had with regard to the above defence so that I could use my legal expertise to play the part of devil's advocate. It should be brought to your attention that the group has access to documentation of which we members of the judiciary have little knowledge. I refer to the British Parliamentary Papers for the Colony of Australia for the years 1860 through to 1922.

These are photocopies of all documents correspondence etc., between the states and later the Commonwealth of Australia, the British Crown and the British Government. They are very revealing documents and indicate the degree of chicanery in which the politicians of all shades were involved and as I can now see, at the expense of the legal academe and the judiciary. I present for your perusal the details of the group's presentation along with my comment on each major item. The group relies solely upon historical fact and rejects political rhetoric and legal opinion unless based upon historical fact.

1. "The Commonwealth of Australia Constitution Act 1900 (UK) is an act of the parliament of the United Kingdom. It did not contain any substance of sovereignty and was a colonial act centralising self-government of the six Australian Colonies. Australia remained a colony of the United Kingdom."
 - 1a. Although the late Lionel Murphy attempted to show that there was an element of sovereignty in this act, he failed to do so. The international definition of sovereignty has been espoused at length and the above act although important in the development of Australia, did not have the authority of sovereignty. The historical evidence that Australia remained a British Colony post 1901 is overwhelming.
2. "Australia made an international declaration of its intention to become a sovereign nation when Prime Minister Hughes and his deputy; Sir Joseph Cook signed the Treaty of Versailles on June 28, 1919. On its cognisance of signing this treaty, Australia was granted a "C" class League of Nations mandate over former German territories in the Pacific. In effect, Papua New Guinea became a colony of Australia achieving its own independence on 16 September 1975. The League of Nations became part of International Law on 10 January 1920 with Article X of the Covenant of League of Nations guaranteeing the sovereignty of each member."
 - 2A. The Significance of Australia joining the League of Nations as a foundation member has never been

addressed in Australia before. Strangely, only one book has ever examined the question of Australian independence. Written by W. J. Hudson and M. P. Sharp in 1988 "Australian Independence" printed by Melbourne University Press. As both were members of the Department of Foreign Affairs and Trade at the time of authorship and had access to the, British Parliamentary Papers, I find it most interesting they have avoided any mention of these papers in their book. Their conclusion that Australia became an independent nation via. the Statute of Westminster in 1931 flies in the face of contradictory evidence within the above mentioned papers and readily available historical fact.

Prime Minister Hughes address to the Commonwealth Parliament on 10 September 1919, "Australia has now entered into a family of nations on a footing of equality. Australia has been born in a blood sacrifice" demonstrates that the politicians of the day were only too well aware of the change of status from a colony to that of a sovereign nation, while attempting to remain within the Empire.

Prime Minister Bruce made this reply to the British Government in 1922 after a request for troops against Kernel Ataturk in the Chanak crisis. Bruce's reply is contained in the British Parliamentary Papers: "We have to try to ensure there shall be an Empire foreign policy which if we are to be in anyway responsible for it, must be one to which we agree and to which we have assented. If we are to take any responsibility for the Empire's foreign policy, then there must be a better system, so that we may be consulted and have a better opportunity to express the views of the people of this country. We cannot blindly submit to any policy which may involve us in war." This is a far cry from the declaration of war against Germany made on behalf of the British Colony of Australia by George V of the United Kingdom in 1914.

I have reproduced Bruce's reply in full as I believe this reply contains clear historical evidence of a Prime Minister who was well aware of the change of status from a colony to a sovereign nation. The later Statute of Westminster 1931 was an acknowledgment of that status.

3. "Paragraph 4 of the Statute of Westminster Act 1931 contravenes Article X of the Covenant of the League of Nations. Paragraph 1 of the Australia Act 1986 contravenes Article 2 paragraphs 1 and 4 of the Charter of the United Nations."

3A Paragraph 4 of the Statute of Westminster reads "No Act of Parliament of the United Kingdom, passed after the commencement of this Act, shall extend, or be deemed to extend, to a Dominion as part of the law of that Dominion, unless it is expressly declared in that Act, that the Dominion, has requested, and consented to the enactment thereof." Paragraph 1 of the Australia Act is very similar: "No Act of the Parliament of the United Kingdom passed after the commencement of this Act shall extend, or be deemed to extend, to the Commonwealth, to a State or Territory as part of the law of the Commonwealth, of the State or of the Territory."

I passed this one to the Federal Attorney General and asked him what was the source of this quite incredible authority that sought to overturn the authority legislated within the Covenant of the League of Nations in Article X and the Charter of the United Nations in Article 2 paragraphs 1 and 4. He is unable to provide any documentation to support these clauses, Article X of the Covenant of the League of Nations states: "The members of the League undertake to respect and preserve against external aggression the territorial integrity and existing political independence of all Members of the League. In case of any such aggression or in case of any threat or danger of such aggression, the Council shall advise upon the means by which this obligation shall be fulfilled."

It is appropriate that I now introduce a statement by Sir Geoffrey Butler KBE, MA and Fellow, Librarian and Lecturer in International Law and Diplomacy of Corpus Christi College, Cambridge author of "A Handbook to the League of Nations" used as a reference to the League by virtually all nations at that time. He refers to Article 1 of the Covenant of the League of Nations:

"It is arguable that this article is the Covenant's most significant single measure. By it the British Dominions, namely New Zealand, Australia, South Africa, and Canada, have their independent nationhood established for the first time. There may be friction over small matters in giving effect to this internationally acknowledged fact but the Dominions will always look to the League of Nations Covenant as their Declaration of Independence.

Article 2 paragraph 1 of the United Nations Charter states "The Organisation is based on the principle of the sovereign equality of all of its Members."

Article 2 paragraph 4 of the Charter states 'All members shall refrain in their international relations, from the threat or use of force against the territorial integrity or political independence of any state, or in any other manner inconsistent with the Purposes of the United Nations.'

In view of the above, the historical evidence for Australian Independence by 10 January 1920 when the League of Nations became part of International Law is overwhelming. When this evidence is reinforced with the contents of

the Charter of the United Nations, the continued usage of any legislation that owes its very legitimacy to the parliament of an acknowledged foreign power cannot be supported by either legal opinion or indeed historical evidence.

I therefore have come to the conclusion that the current legal and political system in use in Australia and its States and Territories has no basis in law.

Following discussions with members of the British Government relating to the Letters Patent for the Governor General and State Governors I find that these documents no longer have any authority. Indeed, the Queen of the United Kingdom is excluded from any position of power in Australia by the United Nations Charter and is excluded under UK law from the issue of a Letters Patent to other than a British Subject. A Letters Patent must refer to an action to be taken with regard to British Citizens. In the Immigration Act 1972, the UK defines Australian Citizens as "aliens".

The Governor General's Letters Patent is a comedy of errors. We are greeted in the name of the Queen of Australia who suddenly becomes the Queen of the United Kingdom in the next paragraph of the Letters Patent. This Queen then gives instructions to the Governor General with reference to the Commonwealth of Australia Constitution Act 1900 UK. Here we have a clear breach of Article 2 paragraph 1 of the United Nation Charter. Under both UK and international law, the-Queen is a British Citizen.

State Governors are in a worse position since their authority comes from the late Queen Victoria of the United Kingdom. Regardless of the validity of the Commonwealth of Australia Constitution Act 1900 UK, if the authority of Governor General and the State Governors is invalid then so is the entire political and legal system of government.

When advised that the War Crimes Commission was taking an interest, I called them in Geneva. Under the 1947 Geneva Convention, they are empowered to look into cases here in Australia where it is alleged that the law of a foreign country was enforced against a citizen of a member state of the United Nations. As they perceive that only the judiciary can actually enforce the law, the judiciary becomes their target. The group has already placed cases before them which they are currently investigating. If found guilty, the penalties are horrific and include the death penalty!

I could go on with more relevant information however I think now is the time for a summary. The group leader, a QC, states the obvious when he asked me how could a colony now acknowledged by all world nations to be a sovereign Nation, retain exactly the same legal and political system which it enjoyed as a colony, without any change whatsoever to the basis for law. This point alone requires an answer.

The High Court has already answered with regard to the position held by treaties signed by the Commonwealth Government in the Teoh case of 1994. "Ordinary people have the right to expect government officials to consider Australia's international obligations even if those obligations are not reflected in specific Acts of Parliament: the rights recognised in international treaties are an implied limit on executive processes."

My advice is to adjourn any case "sine die" that challenges the authority of the Letters Patent. Under no circumstances hear a case that challenges the validity of a State or the Federal Constitution. It is the politicians who are using us as pawns without them having to face the music. If these matters are of concern to politicians, then let them sort out these problems and accept any inherent risks themselves! Article 36 of the Statute of the International Court of Justice is the correct reference for you to refuse to hear a matter when an international treaty is cited as a defence.

The Comments of Brian Collins

The following is some of what the very knowledgeable Brian Collins has to say on his web site. I merely quote what he says here and I have not verified any of this material, and so I recommend that you check out these things for yourself.

The Greatest Lie Ever Told

The government and legal system of the United States, Canada, Australia, New Zealand and of course, Britain, is totally controlled by the Crown. The Crown is **not** the British Monarch. The Crown is the Inner City of London, which is an independent State in London belonging to the Vatican system. It is a banking cartel which has a

massive system around and beneath it, which hides its true power. The City is in fact, the Knights Templar Church, also known as the 'Crown Temple' or 'Crown Templar', and is located between Fleet Street and Victoria Embankment. The Temple grounds are also home to the Crown Offices at Crown Office Row.

The Crown Temple controls the Global 'Legal' system, including those in the United States, Canada, Australia, and much more; this is because all Bar Associations are franchises of the International Bar Association at the Inns of Court at Crown Temple based at Chancery Lane in London. All Bar Associations are franchises of the Crown and all Bar Attorneys/ Barristers throughout the world pledge a solemn oath to the Temple, even though many may not be aware that this is what they are doing. Bar Association 'licensed' Solicitors / Barristers must keep to their Oath, Pledge and terms of allegiance to the Crown Temple if they are to be "called to the Bar" and work in the legal profession. The ruling Monarch is also subordinate to the Crown Temple, this as been so since the reign of King John in the 13th century when Royal Sovereignty was transferred to the Crown Temple and, through this, to the Roman Church. King John 1167-1216 is the key to this deception.

It was at the Chancel, or Chancery, of the Crown Inner Temple Court in January 1215 that King John was faced with the demands of the French/English Barons in England (mainly French), to confirm the rights enshrined in the Magna Carta. When he signed the Magna Carta in 1215 history records this as an event that extended human freedom, but the real affect was very different as we shall see. The governments of the USA, Canada, Australia and more, are subsidiaries of the Crown Temple and so is the US Central Bank the Federal Reserve, as are all Central Banks on the planet, including the IMF World Bank.

Bar Associations are awarded their franchises by the Four Inns of Court at Temple Bar. These are the Inner Temple, Middle Temple, Lincolns Inn and Greys Inn and they are nothing less than elite secret societies without charters or statutes. They are the law unto themselves. The Inner Temple controls the legal system franchise for Canada and Britain while the Middle Temple does the same for the United States. Queen Elizabeth II is a member of both Temples. At least five signatories to the American Declaration of Independence were Temple Bar Attorneys who had pledged allegiance to the Crown! Another Middle Temple operative during the formation of the USA was Alexander Hamilton who structured the American Banking system to fulfil the Crown Temples agenda for total control of the United States. So in truth, a State wherever it is on this planet, is a legal entity of the Temple Crown, or a Crown Colony. A man named Michael Edwards wrote:

"Americans were fooled into believing that the legal Crown Colonies comprising New England, were independent nation states, but they never were, nor are they today. They were, and still are, Colonies of the Crown Temple, through letters patent and charters, who have no legal authority to be independent from the rule and order of the Crown Temple. A legal state is a Crown Temple Colony".

"Neither the American people nor the monarch of Britain own America. The Crown Temple owns America through the deception of those who have sworn their allegiance by oath to the Middle Temple Bar. The Crown Bankers and their Middle Templar Attorneys rule America through unlawful contracts, unlawful Taxes, and contract documents of false equity through debt deceit, all strictly enforced by their completely unlawful, but 'legal', orders, rules and codes of the Crown Temple Courts, or the so called, 'Judiciary', in America. This is because the Crown Temple holds the land titles and estate deeds to all of North America".

Seven Middle Inn Templars who had pledged an oath of allegiance to the Crown Temple (including Alexander Hamilton) were among the members of the Constitutional Convention who signed the completed 'American Constitution'. How symbolic it is that copies of the American Constitution and the Declaration of Independence hang on the wall of the Middle Temple in London. It's not that surprising when you consider that this Temple controlled both sides in these shenanigans.

So while the Middle Bar Templars were orchestrating the illusion of freedom from the perceived rule by King George III, the King too, was a sworn member of the same Temple. Michael Edwards continues:

"1776 is the year that will truly live in infamy for all Americans. It is the year that the Crown Colonies became legal Crown States. The Declaration of Independence was a legal, not lawful, document. It was signed on both sides by representatives of the Crown Temple. Legally, it announced the status quo of the Crown Colonies to that of the new legal name called 'States' as directly possessed estates of the Crown.

"The American people were hoodwinked into thinking that they were declaring lawful independence from the Crown. The proof that the colonies are still a Crown possession is the use of the word 'State' to signify a 'legal estate of possession'. Had this been a document "of and by the people", then both the Declaration of Independence and the US Constitution would have been written using the word 'States'. By the use of 'State', the significance of government of estate possessions was legally established. All of the North American States are Crown Templar possessions through their legal document, signed by their representation of both parties to the contract, known as the Constitution of the United States of America.

Who controls the Crown? On 15th May 1213, King John, being a puppet of the Knights Templar, effectively signed away the Kingdom of England and Ireland to Pope Innocent III and the Roman Church, witnessed by the Crown Templars. As King John said at the time: "I myself bearing witness in the house of the Knights Templars".

The King John Charter said:

" We wish it to be known to all of you, through this our charter, furnished with our seal... not induced by force or compelled by fear, but of our own good and spontaneous will and by common counsel of our Barons, do offer and freely concede to God and his Holy Apostles Peter and Paul and to our mother the holy Roman Church, and to our lord Pope Innocent and to his Catholic successors, the whole kingdom of England and the whole kingdom of Ireland, with all their rights and appurtenances... we perform and swear fealty for them to him are aforesaid lord pope Innocent, and his Catholic successors and the Roman Church...

binding our successors and our heirs by our wife forever, in a similar manner to perform fealty and show homage to him who shall be chief pontiff at the time, and to the Roman church without demur. As a sign... we will and establish perpetual obligation and concession... from the proper and especial revenues of our aforesaid kingdoms...

the Roman church shall receive yearly a thousand marks sterling... saving to us and to our heirs our rights, liberties and regalia; all of which things, as they have been described above, we wish to have perpetually valid and firm; and we bind ourselves and our successors not to act counter to them. And if we or any of our successors shall presume to attempt this, whoever he be, unless being duly warned he come to his kingdom, and his senses, he shall lose his right to the kingdom, and this charter of our obligation and concession shall always remain firm."

Now it gets interesting. Historical accounts concentrate on the fact that this charter obliged the Crown to pay money to the Roman Church, but it also states that if the terms of the charter are broken, the 'right to the kingdom' shall be lost. When King John signed the Magna Carter on 15th June 1215, he broke the terms of the charter with the Pope and therefore lost the right to his Kingdom. Pope Innocent III then declared the Magna Carter to be null and void. From that time, the 'Crown' passed from the Monarch to the Knights Templar who to this day, govern Britain on behalf of the Roman Illuminati Church.

The St Clair's now Sinclair are the initial directors of this link of Templar and Rome in the British Isles as they took hold in Scotland at the time of the 1066 Norsemen-Norman invasion. This means that ultimately, through the Crown Temple, the Roman system also owns the United States, Canada and all countries and Bar associations controlled both overtly and covertly by the Crown. This is why the Peace Treaty between the American Colonies and the British Crown in 1783, stated:

"It having pleased the Divine Providence to dispose the hearts of the most serene and most potent Prince George the third, by the grace of God, King of Great Britain, France and Ireland, defender of the faith, Duke of Brunswick and Luneburg, arch treasurer and prince elector of the Holy Roman Empire etc... and of the United States of America..."

And ironically, a Roman Catholic is barred from being the British Monarch while all along the Monarch and the Kingdom have been owned by the system that is Rome.

The Queen is the Grand Patroness of Freemasonry. She is served by the 390 members of the Privy Council which connects with it's equivalent in all other Commonwealth Countries. The Privy Council is 'LEGALLY' above Parliament because of its prerogative powers. It's members, are appointed for life and they include Prince Philip, Prince Charles, the Archbishop of Canterbury, the Prime Minister and many others. They hold nine official meetings each year and the government (Crown) minister's stand to attention while the Queen is told of the government measures they are asking the Queen to approve, which are nothing other than what the Crown dictates via the elected leader and via the Whips of whichever political party has power... After taking their bow to the Queen and shaking her hand they are sworn to conduct their business in the utmost secrecy.

Another network of this structure is the CROWN AGENTS. Formed in 1833 as 'Crown Agents for the Colonies', to run the day to day administration of the empire and to serve as private bankers to government officials, colonial authorities, and heads of state. It is also an older version of Brown & Root supplying a vast range of goods throughout the empire. Goods that included arms, drugs, viruses, especially to Africa to create the genocidal wars we are now witnessing and have witnessed in the past. The 'Crown Agents' is the network which links the Crown Temple to the organised crime operations throughout the empire, the Golden Dawn being one of the most powerful occult operations to be used in Britain amongst the crime syndicates to ensure that the right crime waves are in full swing when required.

We can see this in the current agenda for guns. The Golden Dawn also operates within legal organisations, but is the interconnecting network across all secret societies and religion. Remember that the Crown Agents work

directly for the Monarch who works for the Knights Templar Church, which operates for the Vatican, and to add insult to injury, the entire debt of the Crown Agents is guaranteed by the British Government, and that means you!

In the 1970's it was bailed out by the Bank of England costing hundreds of millions of pounds. For many years the Crown Agents managed the personal wealth of the Sultan of Brunei who just happens to be a great friend of the Queen, and who has funded many of Prince Philip's, Prince Charles', and George Bush senior's private projects. The Sultan is also the financier of both the British and the American unofficial intelligence operations as he has backed many of Mohammed Al Fayed's operations, in fact the Sultan could be said to be Mohammed Al Fayed!

After the murder of Princess Diana, the role of Al Fayed was for him to hijack the conspiracy and thus lead investigators down the Al Fayed rap of misinformation as was done with Nick Brown over the top-up fees debate, and is currently being played by David Davis. Fortunately no one needed to go to him for information because we all in our hearts already know that she was murdered.

In 1996 the 'Crown Agents' operation was privatised and given the name 'Crown Agents for Overseas Government and Administration Ltd'. Of course, privatisation is nothing but transfer of Power from Crown Temple through Government agency to Crown Temple via direct ownership: they own everything in this nation!

Just to give an idea of What the Crown Agencies controls, here are a few little companies which it controls. It acts as a holding company for:

Barclays bank
Standard and Chartered bank
Unilever
Tate and Lyle
Securicor
British Telecom
The Prince of Wales Business Leaders Forum, and
Aga Khan Foundation

I think you get the picture; it's big to say the least.

It manages the customs services of Mozambique, and through a company called Europe SA, it is in charge of all of the economic construction procurement for Bosnia. It is also in a joint venture with the Monaco-based company ES-KO, to provide all the food for United Nations peace keeping forces in Angola and Bosnia. So, the more war the more profit for the Crown Agents, and if it were to fail financially, then the British Taxpayer will have to foot the bill !!!!

The queen of England owns the 40,000 acre Duchy of Lancaster, and the 44,000 acre Duchy of Cornwall which gives Charles his income. In truth, it is the Crown that owns these assets, which are assigned to the ruling monarch, so long as they do as they are told. The Crown, it transpires, owns land in the UK to the tune of 40 million acres. The Queen owns over 300 residences around the country, and invests heavily in corporations like Rio Tinto Zinc, Royal Dutch Shell, ICI, and General Electric. This is no surprise as these companies are 100% Illuminati operations.

Rio Tinto is the largest mining company in the world and was established in 1873 by Hugh Matheson of the Global drug running operation Jardine Matheson. Rio Tinto was in at the start of the North Sea Oil, along with Texaco. They used the refineries of BP in which the Queen also has massive investments, so now you know where all the revenues from the North Sea oil reserves went - to the Crown Temple. This shows insider dealing on an individual basis enabling the Queen to make massive profits.

Another blatant conflict of interest to have been identified, was Rio Tinto's involvement in a cartel formed in 1971 to fix the price of uranium. A Federal grand jury and the 1976 US Senate Foreign Relations Committee, chaired by Frank Church, exposed the sting. It also included a company called Mary Kathleen Uranium of Australia. This company had been secretly encouraging the Aborigines to occupy uranium-rich lands in Australia to take these lands out of production in order to raise the price of uranium on the world market. The manipulated shortage of uranium had a serious effect on the American Westinghouse company who sought to take legal action against Rio Tinto for price rigging.

This strategy has been used in the USA against the Native Americans and throughout Africa. An American court ordered that Rio Tinto officials answer questions, but this was quashed by the British Law Lords. The Australian government passed legislation to the same effect. This was after the Australian Prime Minister, Gough Whitlam, had been dismissed from office by the Queen's Governor General of Australia, Sir John Kerr. Whitlam was pursuing a policy of buying out the mining and raw material cartels, like Rio Tinto and Anglo American, to stop them rapping Australia's resource base, while giving nothing in return.

The Queen having enormous investments in both companies, removed Whitlam by using some of her wide range of prerogative powers, which by the way, she has in all commonwealth countries including Britain, which she can instigate when the Crown deem necessary, but of course in the minds of the masses the Queen has no powers today! Well I suppose she doesn't in that she is a puppet of the Crown Temple and ultimately, of the Roman system. Sir John Kerr, a former high level operative of British Intelligence, was made a member of the Privy Council and the Royal Victorian Order for his loyal and most profitable service to the Queen's portfolio.

He was later murdered however, when the truth about the removal of Gough Whitlam was in danger of coming out - how they look after their own! He was obviously outer circle, and a good man and would have exposed the lies of the inner circle. The Crown Cartels continue through a House of Windsor extremely secretive society called the Club of the Isles. It was named after King Edward VII, Queen Victoria's son.

The title is held today by Prince Charles. King Edward VII was heavily involved with the Black Nobility barons of 'the square mile of London' Financial District and helped them to engineer the Crimean War, the Russia - Japan War, the preparations for the First World War, and the Opium Wars against China. Through the central organisation of the Club of the Isles comes the fantastic web of interlocking directorships which holds apparently 'independent' companies in a network of common control and common agenda. Part of that web includes:

The Bank of England
Anglo American Corporation of South Africa
Rio Tinto
Minorco Minerals and Resources Corp
De Beers Consolidated Mines
De Beers Centenary AG
N.M Rothschild's Bank
Barclays Bank
Lloyds Bank
Lloyds Insurance Market
HSBC Bank
National Westminster Bank
Barings Bank
Schroders bank
Standard Chartered Bank
Hambros Bank
S.G Warburg
Toronto Dominion Bank
Johnson Matthey
Kleinwort Benson Group
Lazard Brothers
Lonrho
J.P Morgan and CO
Morgan Grenfell Group
British Petroleum
Shell and Royal Dutch Petroleum
Cadbury - Schweppes
Bat Industries
Assicurazioni Generali SpA (VeniceItaly)
Courtaulds
General Electric
Cazeenove and Co
Grand Metropolitan
Hanson PLC
HSBS (Hong Kong and Shanghai Bank)
Imperial and Chemical Industries (ICI)
Inchscape PLC
Inco Ltd.
ING Group
Jardine Matheson
Peninsular and Oriental Steam Navigation & Co (P & O ferries)
Pilkington Glass
Reuters Holdings
Glaxo Wellcome
Smithkline Beecham
Unilever and UnileverNV

Vickers PLC.

This is just a few of them. In 1999, Lonrho had 640 subsidiary companies itself; today, it has many more, and all of these companies have themselves, staggering numbers of subsidiaries. In studying the subsidiaries of the multi-nationals, you arrive at the fact that everything is controlled by the Crown, and that all of them lead back to operatives of the Roman Illuminati Church via the Knights Templar Church.

A fact worth noting is that just because a company like Pilkington Glass is now perceived to be owned by a non-British company, it has only moved from the British economy, not from the control or economy of the Illuminati who own everything, this type of movement is only a movement within the global conglomerate that is the New World Order and still earning for, and controlled by, the bloodline elite, albeit via a different branch of the elite tree.

Just look at some of the TV companies owned and thus controlled by General Electric:

NBC network
CNBC
MSNBC
Bravo
MUN2 TV
Sci-Fi channel
Trio
WNBC - New York
KNBC - Los Angeles
WMAQ - Chicago
WCAU - Philadelphia
KNTV - San Jose - San Francisco
KXAS - Dallas - Fort Worth
WRAC Washington
WTVJ - Miami
KNSDF - San Diego
WVIT - Hartford
WNCN - Raleigh
WCMH - Columbus
WVTM - Birmingham (USA)
WJAR - Providence
KVEA / KWHY - Los Angeles
WNJU - New York
WSCV - Miami
KTMD - Houston
WSNS - Chicago
KXTX - Dallas
KVDA - San Antonio
KSTS - San Francisco
KDRX - Phoenix
KNSO - Fresno
KMAS - Denver
WNEU - Boston / Merrimack
KHRR - Tucson
WKAQ - Puerto Rico
Universal Studios
NBC Universal Television Studio
NBC Universal Television Distribution.

This is one company controlling a major chunk of the TV dream state given out to the whole of America. Is it any wonder that Americans are completely under the control of the American elite?

Another important part of the Windsor network which is part of the Crown Temple, are the City Livery Companies. These purport to represent the various groups of merchants like the gun makers, stationers, newspaper makers, goldsmiths and the like. They are in fact, very secret societies, fundamental to the control of the City institutions and much further afield. In the 1350's, in the wake of the plague known to history as the Black Death, the government of the City passed from the ward councils to the City Livery Companies. In 1979, the year when Margaret Thatcher took power, the Honourable Company of Freemen of the City of London and of North America, began to hold meetings in New York and Toronto, and on 21st October 1991, the Association of Liverymen of the City of London in Hong Kong was founded and all their members were Architects (Freemasons). The late author Peter Jones, researched some of the Livery Companies in the 1990's for his book, 'The Obedience of Australia',

which exposed the manipulation which led to the removal by the Queen, of Australian Prime Minister, Gough Whitlam. These are some of the names which he found within these companies:

Engineers: The Duke of Edinburgh.

Airline Pilots and Navigators: The Duke of Edinburgh Prince Andrew

Butchers: Queen Mother, Lord Vesty (of the meat family and Lord Prior of the Order of St John of Jerusalem)

Merchant Tailors: Queen Mother, Lord Whitelaw

Glovers: Margaret Thatcher, Sir John Fieldhouse (Admiral of the Fleet during the Falklands conflict)

Poulterers: Margaret Thatcher, Duchess of Devonshire.

Fishmongers: Duke and Duchess of Devonshire, C.E.A

Hambro (Hambros Bank, Taylor Woodrow, and P&O), Lord Inchcape (Her Majesty's Lieutenant of London)

Goldsmiths: J.H Hambro.

Grocers: Edward Heath.

Salter's: Duke of Kent (Grand Master of English Freemasonry) Lord Armstrong.

Cloth workers: Sir Peter Gadsden (a Grand Master of the United Grand Lodge), Lord Carrington (Thatcher's handler).

Another name prominent within these companies is McAlpine of the construction family.

You will of course have noted that Prince Philip heads the Pilots and Navigators, which gives indication as to whom is in control of the current attack on our right to travel by plane and the whole swath of legislation about to come out relative to air traffic, using the environment scam to force it through. Just as a matter of interest, the cheap-flight operator 'Easy Jet' is financed by the Warburg Bank which is part of the Rothschild empire which has been proved beyond doubt, to have funded the rise of Hitler's war machine on behalf of the Rothschilds.

The fact that they are now blaming these cheap flight operators for the rise in carbon emissions shows you why the Warburg bank has funded this airline, it is the catalyst for the introduction of the carbon emissions scam. Basically they will determine how much you, as a household, can travel. You have to look at this whole carbon emissions agenda as an attempt to instil a massive suppressing layer of control upon families and business via the introduction of quotas per household.

This will stifle people's movements to unimaginable levels. Don't forget that the House of Rothschild operates directly under the current British chief, Prince Philip. Prince Philip's whole family were supporters of the Nazi's as was he himself. In 1935, Prince Christoph, the husband of Philip's sister Sophie, was a colonel in the SS of Himmler's personal staff and head of the Forschungsamt, an elite intelligence operation controlled by Hermann Goering.

It was they who carried out the famous 'Night of the Long Knives' when Hitler removed his key opponents. Christoph and Sophie named their eldest child, Karl Adolf, after Hitler and Prince Philip was involved in his education. Christoph's brother, Philip of Hess, was related to the King of Italy and was the official liaison between the fascists of Italy and Germany. Also at the same time the British King Edward VIII, who was forced to abdicate in order the Queen Mother could be placed in the position of Chief Toad which meant she had to marry the lesser of the brothers, Bertie, the one she could obviously control.

King Edward VIII was well known to be a Nazi supporter. Prince Philip kept up very serious connections with Edward even after his abdication in 1936. Another of Edward's supporters, and mentor to Prince Philip, was the known paedophile and Satanist Lord Louis Mountbatten (Battenberg). Mountbatten was Philip's route into the House of Windsor. Mountbatten was the grandson of Queen Victoria and Prince Albert and was born at Windsor Castle in 1900. While Mountbatten was supposedly fighting on the British side during the war, he maintained serious communications with the Windsor's German Clan via his sister Louise, the Crown Princess of Sweden and wife of King Gustav. Louise was Prince Philip's aunt.

At the end of the war, in June 1945, the British King, George VI, the father of Queen Elizabeth and puppet of the Queen Mother, sent the former MI5 officer, Anthony Blunt, to the Kronberg Castle of Prince Philip's sister Sophie,

and her Nazi husband Prince Christoph of Hess, to recover correspondence between the British Royal Family and their Nazi relatives, for propaganda aimed at convincing the aristocrats of Britain they had not been in contact all along. Blunt was the 'surveyor of the Queens Pictures' and a world expert in the paintings of Poussin, the initiate who painted pictures called 'The Shepherds of Arcadia' which related to the Rennes-le-Chateau mysteries. Blunt was named as a member of a KGB unit inside British Intelligence along with Burgess, MacLean, and Philby, the fifth man was never named, but was in fact, Lord Victor Rothschild.

If you have seen the latest Bond movies, you hear the Character 'M' played by Dame Judy Dench state, ' in the cold war days intelligence operatives that made a big mistake had the common decency to defect', of course they would the intelligence services of the world are one and the same. When Blunt was finally caught in the 1980's, Queen Elizabeth II demanded he was not questioned on his clandestine mission to Kronberg Castle... So who controls the law?

Another important secret society within the Crown Temple is the Knights Grand Cross of the Order of the Bath, sounds pretty strange until you understand its symbolism. Both George Bush snr. and Ronald Reagan were given this title. The resurrection bath of alchemy, symbolises rebirth and purification or absolution. Baths are given to Masonic Knights of the Bath before they perform horrendous deeds, hence the term 'Blood Baths'.

The information in the last few paragraphs only hints at the true power of the Crown Temple. One has also to include all that the Vatican openly controls, to see the true extent of the power of the Roman Illuminati Church to which the Knights Templar Church is subordinate. Through all these networks and more, thirteen Royal Nefilim families control the world, and it is they who are carrying out all of the atrocities in the world at this present time, to carry out the agenda of the Elohim.

The Crown also owns massive parts of our coastline around this nation and 12 miles out to sea, in total about half of the coastline. Some of this is under the control of the Ministry of Defence which is itself controlled by the Crown. The current legislation, under which the National Trust will purchase some of this land from the MOD and coast not belonging to the MOD, changes nothing. The National Trust is 100% controlled by the Crown. We have the British Waterways agency, and the railways again controlling massive amounts of land, and we are effectively almost back to the middle ages now.

One of the greatest means to the Windsor land-grab is the:

CLUB OF THE ISLES

Controlling the World Wildlife Fund, WWF, this is one hell of a heinous operation and given the fact that Prince Philip inherited the position as the Queen's husband, becoming Commander of the Club of the Isles...then he is at the helm of genocide the likes of which the Holocaust could never imagine.

I see that the Royals are playing the good guys relative to the Sunni Muslims with the release of the Manchester man after 18 years in prison in Pakistan, this in itself shows you who operates President Musharaff of Pakistan, via such orders as the Order of the Mystic Shrine. This is important, given that Pakistan is now under attack from NATO forces, again controlled by the Inner City banking cartel which includes the Dutch and the Swiss.

So how does the Crown control all the MPs? Answer; via the whip system. All of the MPs which you vote in to represent you, are told how to vote each day by each party's leadership via the whips. So when any politician that has ever been and will be while this system exists, tells lies to the whole population the minute he or she opens his mouth and speaks. No matter what he speaks about, it is saying what he has been told to say, how to speak and when to speak. If it does not obey the whips, then his career is over. Thus the Crown need only control the people at leadership level or the cabinet of each political party and the Whips office, then through that clique of puppets, they demand obedience from all MPs down to the MPs sitting in each constituency, claiming to be acting on behalf of their constituents. The majority of MPs don't even get to see each bill before it goes to the vote, and indeed they don't need to as they are told how to vote on every Bill.

On Sunday 11th February 2007 on the political show 'Sunday AM', Giles Brandreth, a Conservative Party whip stated:

"As a whip, we understand each MP's marital problems, their drinking problems their financial problems, we know a lot about them. We then advise and guide them to making the right decisions".

Do you still feel that MPs act according to their own understanding and emotions? Of course they do not. This is the best I have witnessed from a politician handing you on a plate how the game of politics actually operates. They are all, through fear of their personal information being leaked; totally afraid of the whips, and so do the whips' bidding, which, of course, is the Crown's bidding. All MPs who speak at the box in the Commons do so under oath to the Bible positioned under the box. What does that tell you about those who operate as very

religious people (Blair) when they spew the bullshit? Blair is a high member of the Illuminati and that is why he can lie with ease as he speaks to the House and the people.

The Economic Techniques

The following is an excerpt from a document, dated May 1979, and which appears to be a statement of the methods and techniques used in the economic warfare which is being waged against all ordinary people at this time. Let me emphasise that these are not my words but that I am quoting the contents of an old and unverified document of unknown origin. Anonymous documents are a standard method of spreading disinformation, however, the statements quoted below are included because they have every appearance of being a factual New World Order strategy already being implemented.

Top Secret

Silent Weapons for Quiet Wars, An introductory programming manual, Operations Research Technical Manual TM-SW7905.1 This publication marks the 25th anniversary of the Third World War, called the "Quiet War", being conducted using subjective biological warfare, fought with "silent weapons." May 1979

Security

It is patently impossible to discuss social engineering or the automation of a society, i.e., the engineering of social automation systems (silent weapons) on a national or worldwide scale without implying extensive objectives of social control and destruction of human life, i.e., slavery and genocide. Whenever any person or group of persons in a position of great power and without full knowledge and consent of the public, uses such knowledge and methodologies for economic conquest - it must be understood that a state of domestic warfare exists between that person, or group of persons, and the public. The solution of today's problems requires an approach which is ruthlessly candid, with no agonizing over religious, moral or cultural values.

Historical Introduction

Silent weapon technology has evolved from Operations Research ("OR"), a strategic and tactical methodology developed under the Military Management in England during the Second World War. The original purpose of Operations Research was to study the strategic and tactical problems of air and land defence with the objective of effective use of limited military resources against foreign enemies (i.e., logistics). It was soon recognised by those in positions of power that the same methods might be useful for totally controlling a society, but better tools were needed.

Social engineering (the analysis and automation of a society) requires the correlation of great amounts of constantly changing economic information (data), so a high-speed computerised data-processing system was necessary which could predict when society would arrive at the point of capitulation. Mechanical computers were too slow, but the electronic computer fills the bill. The next breakthrough was the development of the simplex method of linear programming in 1947 by the mathematician George B. Dantzig. Then in 1948, the transistor, promised great expansion of the computer field by reducing space and power requirements.

With these three inventions, those in positions of power strongly suspected that it was possible for them to control the whole world. Immediately, the Rockefeller Foundation got in on the ground floor by making a four-year grant to Harvard College, funding the Harvard Economic Research Project for the study of the structure of the American Economy. One year later, in 1949, The United States Air Force joined in. In 1952 the grant period terminated, and a high-level meeting of the Elite was held to determine the next phase of social Operations Research. The Harvard project had been very fruitful, as is borne out by the publication of some of its results in 1953 suggesting the feasibility of economic (social) engineering. (Studies in the Structure of the American Economy - copyright 1953 by Wassily Leontief, International Science Press Inc., White Plains, New York).

Engineered during the last half of the 1940's, by 1954 the new Quiet-War machine was ready. With the creation of the maser in 1954, the promise of unlocking unlimited sources of fusion atomic energy from the heavy hydrogen in sea water and the consequent availability of unlimited social power was a possibility only decades away. The combination was irresistible. The Quiet War was quietly declared by the International Elite at a meeting held in 1954. Although the silent weapons system was nearly exposed 13 years later, the evolution of the new weapon-system has never suffered any major setbacks. This year of 1979 marks the 25th anniversary of the beginning of the Quiet War. Already this domestic war has had many victories on many fronts throughout the world.

Political Introduction

In 1954 it was well recognised by those in positions of authority, that it would be only a few decades, before the general public would be able to grasp and upset the cradle of power, for the elements of the new silent-weapon

technology were as accessible for use in providing a public utopia as they were for providing a private utopia. So, the issue of primary concern, namely that of dominance, revolved around the subject of the energy sciences.

Energy

Energy is recognised as the key to all activity on earth. Natural science is the study of the sources and control of natural energy, and social science (theoretically expressed as economics) is the study of the sources and control of social energy. Both are bookkeeping systems based on mathematics. Therefore, mathematics is the primary energy science and the bookkeeper can be king if the public can be kept ignorant of the methodology of the bookkeeping.

All science is merely a means to an end. The means is knowledge. The end is control. Beyond this remains only one issue: Who will be the beneficiary? In 1954 this was the issue of primary concern. Although the so-called "moral issues" were raised, in view of the law of natural selection it was agreed that a nation or world of people who will not use their intelligence are no better than animals who do not have intelligence. Such people are beasts of burden and steaks on the table by choice and consent.

Consequently, in the interest of future world order, peace, and tranquillity, it was decided to wage a private quiet war against the American public with an ultimate objective of permanently shifting the natural and social energy (wealth) of the undisciplined and irresponsible many into the hands of the self-disciplined, responsible, and "worthy" few.

In order to implement this objective, it was necessary to create, secure, and apply new weapons which, as it turned out, were a class of weapons so subtle and sophisticated in their principle of operation and public appearance as to earn for themselves the name of "silent weapons." In conclusion, the objective of economic research, as conducted by the magnates of capital (banking) and the industries of commodities (goods and services), is the establishment of an economy which is totally predictable and which can be manipulated.

In order to achieve this totally predictable economy, the low-class elements of society must be brought under total control, i.e., They must be housebroken, trained, and assigned a yoke and long-term social duties from a very early age, before they have an opportunity to question the propriety of the matter. In order to achieve such conformity, the lower-class family unit must be disintegrated by a process of increasing preoccupation of the parents and the establishment of government-operated day-care centres for the occupationally orphaned children.

The quality of education given to the lower class must be of the poorest sort, so that the moat of ignorance isolating the inferior class from the superior class is and always remains, incomprehensible to the inferior class. With such an initial handicap, even bright lower class individuals have little if any hope of extricating themselves from their assigned lot in life. This form of slavery is essential to maintain some measure of social order, peace, and tranquillity for the ruling upper class.

Descriptive Introduction to the Silent Weapon

Everything which can be expected from an ordinary weapon is also expected from a silent weapon by its creators, but only in its own manner of functioning. It shoots situations, instead of bullets; its propellant is data processing, instead of the conventional chemical explosion. The power originates from bits of data in a computer, instead of grains of gunpowder inside a gun. The operator is a computer programmer, instead of a military marksman, and the orders are issued by a banking magnate, instead of a military general. It makes no obvious explosive noises, causes no obvious physical or mental injuries, and does not interfere in an obvious way with anyone's daily social life.

However, it makes an unmistakable "noise," causes unmistakable physical and mental damage, and interferes unmistakably with daily social life, that is, in ways which are unmistakable to a trained observer who knows what to look for. The public cannot comprehend this weapon, and therefore cannot believe that they are being attacked and subdued by a weapon. The public might instinctively feel that something is wrong, but because of the technical nature of the silent weapon, they cannot express their feeling in any rational way, or handle the problem with intelligence. Therefore, they do not know how to call for help, nor do they know how to associate with others to defend themselves against it.

When a silent weapon is applied gradually, the public adjusts and adapts to its presence and learns to tolerate its encroachment on their lives until the psychological pressure (applied via economic methods) becomes too great and they crack up. Therefore, in a way, the silent weapon can be considered to be a type of biological weapon. It attacks the vitality, options, and mobility of the individuals of a society by knowing, understanding, manipulating, and attacking their sources of natural and social energy, and their physical, mental, and emotional strengths and weaknesses.

Theoretical Introduction

"Give me control over a nation's currency, and I care not who makes its laws." - Mayer Amschel Rothschild (1743

- 1812). Today's silent weapons technology is an outgrowth of a simple idea discovered, succinctly expressed, and effectively applied by Mr. Mayer Amschel Rothschild. Mr. Rothschild discovered the missing passive component of economic theory known as economic inductance. He, of course, did not think of his discovery in these twentieth century terms, and, to be sure, mathematical analysis had to wait for the Second Industrial Revolution, the rise of the theory of mechanics and electronics, and finally, the invention of the electronic computer before it could be effectively applied in the control of the world economy.

General Energy Concepts

In the study of energy systems, there always appears three elementary concepts. These are:

Potential Energy,
Kinetic Energy, and
Energy Dissipation.

Corresponding to these concepts, there are three idealised, essentially pure physical counterparts called passive components.

In the science of physical mechanics, the phenomenon of Potential Energy is associated with a physical property called Elasticity or stiffness, and can be represented by a stretched spring. In electronic science, Potential energy is stored in a capacitor instead of a spring. This property is called Capacitance instead of Elasticity.

In the science of physical mechanics, the phenomenon of Kinetic Energy is associated with a physical property called Inertia or Mass, and can be represented by a mass or a flywheel in motion. In electronic science, Kinetic Energy is stored in an inductor (in a magnetic field) instead of a mass. This property is called Inductance instead of Inertia.

In the science of physical mechanics, the phenomenon of Energy Dissipation is associated with a physical property called Friction or Resistance, and can be represented by a dashpot or other device which converts energy into heat. In electronic science, Energy Dissipation is performed by an element called either a Resistor.

In economics the equivalents of these three energy concepts are:

Economic Capacitance - **Capital** (money, stock/inventory, investments in buildings and durables, etc.)

Economic Conductance - **Goods** (production flow coefficients)

Economic Inductance - **Services** (the influence of the industrial population on output)

All of the mathematical theory developed in the study of one energy system (e.g., mechanics, electronics, etc.) can be immediately applied in the study of any other energy system (e.g., economics).

Mr Rothschild's Energy Discovery

What Mr. Rothschild discovered was the basic principle of power, influence, and control over people as applied to economics. That principle is "when you assume the appearance of power, people soon give it to you." Mr. Rothschild had discovered that currency or deposit loan accounts had the required appearance of power that could be used to induce people (inductance, with people corresponding to a magnetic field) into surrendering their real wealth in exchange for a promise of greater wealth (instead of real compensation). They would put up real collateral in exchange for a loan of promissory notes. Mr. Rothschild found that he could issue more notes than he had backing for, provided he had someone's stock of gold to show his customers as a persuader.

Mr. Rothschild loaned his promissory notes to individual and to governments. These would create overconfidence. Then he would make money scarce, tighten control of the system, and collect the collateral through the obligation of contracts. The cycle was then repeated. These pressures could be used to ignite a war. Then he would control the availability of currency to determine who would win the war. Any government which agreed to give him control of its economic system got his support. Collection of debts was guaranteed by economic aid to the enemy of the debtor. The profit derived from this economic methodology made Mr. Rothschild all the more able to expand his wealth. He found that the public greed would allow currency to be printed by government order beyond the limits (inflation) of backing in precious metal or the production of goods and services.

Apparent Capital as "Paper" Inductor

In this structure, credit, presented as a pure element called "currency," has the appearance of capital, but is in effect, negative capital. Hence, it has the appearance of service, but it is, in fact, indebtedness or debt. It is therefore an economic inductance instead of an economic capacitance, and if balanced in no other way, will be balanced by the negation of population (war, genocide). The total sum of goods and services represents real capital and it is called the **Gross National Product**, and currency may be printed up to this level and still represent economic capacitance; but currency printed beyond this level is subtractive, represents the introduction of economic inductance, and so becomes notes of indebtedness.

War is therefore the balancing of the system by killing the true creditors (the public which has been taught to exchange true value for inflated currency) and falling back on whatever is left of the resources of nature and regeneration of those resources. Mr. Rothschild had discovered that currency gave him the power to rearrange the economic structure to his own advantage, to shift economic inductance to those economic positions which would encourage the greatest economic instability and oscillation.

The final key to economic control had to wait until there was sufficient data and high-speed computing equipment to keep close watch on the economic oscillations created by price shocking and excess paper energy credits - paper inductance/inflation.

Breakthrough

The aviation field provided the greatest evolution in economic engineering by way of the mathematical theory of shock testing. In this process, a projectile is fired from an airframe on the ground and the impulse of the recoil is monitored by vibration transducers connected to the airframe and wired to chart recorders. By studying the echoes or reflections of the recoil impulse in the airframe, it is possible to discover critical vibrations in the structure of the airframe which either vibrations of the engine or aeolian vibrations of the wings, or a combination of the two, might reinforce resulting in a resonant self-destruction of the airframe in flight. From the standpoint of engineering, this means that the strengths and weaknesses of the structure of the airframe in terms of vibrational energy can be discovered and manipulated.

Application in Economics

To use this method of airframe shock testing in economic engineering, the prices of commodities are shocked, and the public consumer reaction is monitored. The resulting echoes of the economic shock are interpreted theoretically by computers and the psycho-economic structure of the economy is thus discovered. It is by this process that partial differential and difference matrices are discovered that define the family household and make possible its evaluation as an economic industry (dissipative consumer structure). Then the response of the household to future shocks can be predicted and manipulated, and society becomes a well-regulated animal with its reins under the control of a sophisticated computer-regulated social energy bookkeeping system. Eventually every individual element of the structure comes under computer control through a knowledge of personal preferences, such knowledge guaranteed by computer association of consumer preferences (universal product code - the striped bar codes on packages) with identified consumers (initially identified through the use of a credit card and later through a permanent "tattooed" body number invisible under normal ambient illumination).

The Economic Model

The Harvard Economic Research Project (1948-1952) was an extension of World War II Operations Research. Its purpose was to discover the science of controlling an economy: at first the American economy, and then the world economy. It was felt that with sufficient mathematical foundation and data, it would be nearly as easy to predict and control the trend of an economy as to predict and control the trajectory of a projectile. Such has proven to be the case. Moreover, the economy has been transformed into an accurately targeted guided missile.

The immediate aim of the Harvard project was to discover the economic structure, what forces can change that structure, how the behaviour of the structure can be predicted, and how it can be manipulated. What was needed was a well-organised knowledge of the mathematical structures and interrelationships of investment, production, distribution, and consumption. Briefly, it was discovered that an economy obeyed the same laws as electricity and that all of the mathematical theory and practical and computer know-how developed for the electronic field could be directly applied in the study of economics. This discovery was not openly declared, and its more subtle implications were, and are, kept as a closely guarded secret, for example, in an economic model, human life is measured in dollars, and that the electric spark generated when opening a switch connected to an active inductor is mathematically the same as starting a war.

The greatest hurdle which theoretical economists faced was the accurate description of the household as an industry. This is a challenge because consumer purchases are a matter of choice which in turn is influenced by family income, purchase price, and other economic factors. This hurdle was cleared in an indirect and statistically approximate way by an application of shock testing to determine the current characteristics, called current technical coefficients, of a household industry. Finally, because problems in theoretical electronics can be translated very easily into problems of theoretical economics, and the solution translated back again, it follows that only a book of language translation and concept definition needed to be written for economics. The remainder could be got from standard works on mathematics and electronics. This makes the publication of books on advanced economics unnecessary, and greatly simplifies the silent war project security.

Industrial Diagrams

An ideal industry is defined as a device which receives value from other industries in several forms and converts them into one specific product for sales and distribution to other industries. It has several inputs and one output. What the public normally thinks of as one industry is really an industrial complex, where several industries under one roof produce one or more products.

Three Industrial Classes

Industries fall into three categories or classes by type of output:

Class 1 - **Capital** (resources)

Class 2 - **Goods** (commodities or use - dissipative)

Class 3 - **Services** (action of population).

Class 1 industries exist at three levels:

(a) **Nature** - sources of energy and raw materials.

(b) **Government** - printing of currency equal to the gross national product (GNP), and extension of currency in excess of GNP.

(c) **Banking** - loaning of money for interest, and extension (inflation/counterfeiting) of economic value through deposit loan accounts.

Class 2 industries exist as producers of tangible or consumer (dissipated) products. This sort of activity is usually recognised and labelled by the public as "industry."

Class 3 industries are those which have service rather than a tangible product as their output. These industries are called

(a) **Households**, and

(b) **Governments**. Their output is human activity of a mechanical sort, and their basis is population.

Aggregation

The whole economic system can be represented by a three-industry model if one allows the names of the outputs to be:

(1) Capital,

(2) Goods, and

(3) Services.

The problem with this representation is that it would not show the influence of, say, the textile industry on the steel industry. This is because both the textile industry and the steel industry would be contained within a single classification called the "goods industry" and by this process of combining or aggregating these two industries under one system block they would lose their economic individuality.

The E- Model

A national economy consists of simultaneous flows of production, distribution, consumption, and investment. If all of these elements including labour and human functions are assigned a numerical value using common units of measure, say, US dollars at their 1939 value, then this flow can be further represented by a current flow in an electronic circuit, and its behaviour can be predicted and manipulated with useful precision.

The three ideal passive energy components of electronics, the capacitor, the resistor, and the inductor correspond to the three ideal passive energy components of economics called the pure industries of capital, goods, and services.

Economic Capacitance represents the storage of capital in one form or another.

Economic Conductance represents the level of conductance of materials for the production of goods.

Economic Inductance represents the inertia of economic value in motion. This is a population phenomenon known as services.

Economic Inductance

An electrical inductor (e.g., a coil or wire) has an electric current as its primary phenomenon and a magnetic field as its secondary phenomenon (inertia). Corresponding to this, an economic inductor has a flow of economic value as its primary phenomenon and a population field as its secondary field phenomenon of inertia. When the flow of economic value (e.g., money) diminishes, the human population field collapses in order to keep the economic value (money) flowing (extreme case - war). This public inertia is a result of consumer buying habits, expected standard of living, etc., and is generally a phenomenon of self-preservation.

Inductive Factors to Consider

(1) Population

(2) Magnitude of the economic activities of the government

(3) The method of financing these government activities

(See Peter-Paul Principle - inflation of the currency.)

Translation

(a few examples will be given.)

Charge - coulombs - dollars (1939).

Current Flow - amperes (coulombs per second) - dollars of flow per year.

Motivating Force - volts - dollars (output) demand.

Conductance - amperes per volt - dollars of flow per year per dollar demand.

Capacitance - coulombs per volt - dollars of production inventory/stock per dollar demand.

Time-Flow Relationships and Self-Destructive Oscillations

An ideal industry may be symbolised electronically in various ways. The simplest way is to represent a demand by a voltage and a supply by a current. When this is done, the relationship between the two becomes what is called an admittance, which can result from three economic factors:

- (1) **Hindsight flow**,
- (2) **Present flow**, and
- (3) **Foresight flow**.

Foresight flow is the result of that property of living entities to cause energy (food) to be stored for a period of low energy (e.g., a winter season). It consists of demands made upon an economic system for that period of low energy (winter season). In a production industry it takes several forms, one of which is known as production stock or inventory. In electronic symbology this specific industry demand (a pure capital industry) is represented by capacitance and the stock or resource is represented by a stored charge. Satisfaction of an industry demand suffers a lag because of the loading effect of inventory priorities.

Present flow ideally involves no delays. It is, so to speak, input today for output today, a "hand to mouth" flow. In electronic symbology, this specific industry demand is represented by a conductance which is then a simple economic valve (a dissipative element).

Hindsight flow is known as habit or inertia. In electronics this phenomenon is the characteristic of an inductor (economic analogue = a pure service industry) in which a current flow (economic analogue = flow of money) creates a magnetic field (economic analogue = active human population) which, if the current (money flow) begins to diminish, will collapse (war) to maintain the current (flow of money - energy).

Other large alternatives to war as economic inductors or economic flywheels are an open-ended social welfare program, or an enormous (but fruitful) open-ended space program. The problem with stabilising the economic system is that there is too much demand on account of:

- (1) Too much greed and
- (2) Too much population.

This creates excessive economic inductance which can only be balanced with economic capacitance (true resources or value - e.g., in goods or services).

The social welfare program is nothing more than an open-ended credit balance system which creates a false capital industry to give non-productive people a roof over their heads and food in their stomachs. This can be useful, however, because the recipients become state property in return for the "gift," and form a standing army for the Elite - as he who pays the piper picks the tune. Those who get hooked on the economic drug, must go to the Elite for a fix. In this, the method of introducing large amounts of stabilising capacitance is by borrowing on the future "credit" of the world. This is a fourth law of motion - **onset**, and consists of performing an action and leaving the system before the reflected reaction returns to the point of action - a delayed reaction.

The means of surviving the reaction is by changing the system before the reaction can return. By this means, politicians become more popular in their own time and the public pays later. In fact, the measure of such a politician is the delay time. The same thing is achieved by a government by printing money beyond the limit of the gross national product, and economic process called inflation. This puts a large quantity of money into the hands of the public and maintains a balance against their greed, creates a false self-confidence in them and, for a while, stays the wolf from the door.

They must eventually resort to war to balance the account, because war ultimately is merely the act of destroying the creditor, and the politicians are the publicly hired hit men that justify the act to keep the responsibility and blood off the public conscience. If the people really cared about their fellow man, they would control their appetites (greed, procreation, etc.) so that they would not have to operate on a credit or welfare social system which steals from the worker to satisfy the bum. Since most of the general public will not exercise restraint, there are only two alternatives to reduce the economic inductance of the system.

- (1) Let the populace bludgeon each other to death in war, which will only result in a total destruction of the living earth.

(2) Take control of the world by the use of economic "silent weapons" in a form of "quiet warfare" and reduce the economic inductance of the world to a safe level by a process of benevolent slavery and genocide.

The latter option has been taken as the obviously better option. At this point it should be crystal clear to the reader why absolute secrecy about the silent weapons is necessary. The general public refuses to improve its own mentality and its faith in its fellow man. It has become a herd of proliferating barbarians, and, so to speak, a blight upon the face of the earth. They do not care enough about economic science to learn why they have not been able to avoid war despite religious morality, and their religious or self-gratifying refusal to deal with earthly problems, places the solution of the earthly problem beyond their reach.

It is left to those few who are truly willing to think and survive, as the fittest to survive, to solve the problem for themselves as the few who really care. Otherwise, exposure of the silent weapon would destroy our only hope of preserving the seed of the future true humanity.

The Household Industry

The industries of finance (banking), manufacturing, and government, real counterparts of the pure industries of capital, goods, and services, are easily defined because they are generally logically structured. Because of this their processes can be described mathematically and their technical coefficients can be easily deduced. This, however, is not the case with the service industry known as the household industry.

Household Models

The problem which a theoretical economist faces is that the consumer preferences of any household are not easily predictable and the technical coefficients of any one household tend to be a non-linear, very complex, and variable function of income, prices, etc. Computer information derived from the use of the universal product code in conjunction with credit-card purchase as an individual household identifier, could change this state of affairs, but the Universal Product Code method is not yet available on a national or even a significant regional scale. To compensate for this data deficiency, an alternate indirect approach of analysis has been adopted known as economic shock testing. This method, widely used in the aircraft manufacturing industry, develops an aggregate statistical sort of data.

Applied to economics, this means that all of the households in one region or in the whole nation are studied as a group or class rather than individually, and the mass behaviour rather than the individual behaviour is used to discover useful estimates of the technical coefficients governing the economic structure of the hypothetical single-household industry. One method of evaluating the technical coefficients of the household industry depends upon shocking the prices of a commodity and noting the changes in the sales of all of the commodities.

Economic Shock Testing

In recent times, the application of Operations Research to the study of the public economy has been obvious for anyone who understands the principles of shock testing. In the shock testing of an aircraft airframe, the recoil impulse of firing a gun mounted on that airframe causes shock waves in that structure which tell aviation engineers the conditions under which some parts of the airplane or the whole airplane or its wings will start to vibrate or flutter like a guitar string, a flute reed, or a tuning fork, and disintegrate or fall apart in flight. Economic engineers achieve the same result in studying the behaviour of the economy and the consumer public by carefully selecting a staple commodity such as beef, coffee, gasoline, or sugar, and then causing a sudden change or shock in its price or availability, thus kicking everybody's budget and buying habits out of shape. They then observe the shock waves which result by monitoring the changes in advertising, prices, and sales of that and other commodities.

The objective of such studies is to acquire the know-how to set the public economy into a predictable state of motion or change, even a controlled self-destructive state of motion which will convince the public that certain "expert" people should take control of the money system and re-establish security (rather than liberty and justice) for all. When the subject citizens are rendered unable to control their financial affairs, they, of course, become totally enslaved, and a source of cheap labour. Not only the prices of commodities, but also the availability of labour can be used as the means of shock testing. Labour strikes deliver excellent tests shocks to an economy, especially in the critical service areas of trucking (transportation), communication, public utilities (energy, water, garbage collection), etc. By shock testing, it is found that there is a direct relationship between the availability of money flowing in an economy and the real psychological outlook and response of masses of people dependent upon that availability. For example, there is a measurable quantitative relationship between the price of gasoline and the probability that a person would experience a headache, feel a need to watch a violent movie, smoke a cigarette, or go to a tavern for a mug of beer.

It is most interesting that, by observing and measuring the economic models by which the public tries to run from their problems and escape from reality, and by applying the mathematical theory of Operations Research, it is possible to program computers to predict the most probable combination of created events (shocks) which will

bring about a complete control and subjugation of the public through a subversion of the public economy (by shaking the plum tree).

Introduction to Economic Amplifiers

Economic Amplifiers are the active components of economic engineering. The basic characteristic of any amplifier (mechanical, electrical, or economic) is that it receives an input control signal and delivers energy from an independent energy source to a specified output terminal in a predictable relationship to that input control signal. The simplest form of an economic amplifier is a device called advertising. If a person is spoken to by a T.V. advertiser as if he were a twelve-year-old, then, due to suggestibility, he will, with a certain probability, respond or react to that suggestion with the uncritical response of a twelve-year-old and will reach into his economic reservoir and deliver its energy to buy that product on impulse when he passes it in the store.

An Economic Amplifier may have several inputs and output. Its response might be instantaneous or delayed. Its circuit symbol might be a rotary switch if its options are exclusive, qualitative, "go" or "no-go", or it might have its parametric input/output relationships specified by a matrix with internal energy sources represented. Whatever its form might be, its purpose is to govern the flow of energy from a source to an output sink in direct relationship to an input control signal. For this reason, it is called an active circuit element or component. Economic Amplifiers fall into classes called strategies, and, in comparison with electronic amplifiers, the specific internal functions of an economic amplifier are called logistical instead of electrical. Therefore, economic amplifiers not only deliver power gain but also, in effect, are used to cause changes in the economic circuitry.

In the design of an economic amplifier we must have some idea of at least five functions, which are:

- (1) The available input signals,
- (2) The desired output-control objectives,
- (3) The strategic objective,
- (4) The available economic power sources,
- (5) The logistical options.

The process of defining and evaluating these factors and incorporating the economic amplifier into an economic system has been popularly called "game theory". The design of an economic amplifier begins with a specification of the power level of the output, which can range from personal to national. The second condition is accuracy of response, i.e., how accurately the output action is a function of the input commands. High gain combined with strong feedback helps to deliver the required precision. Most of the error will be in the input data signal. Personal input data tends to be specified, while national input data tends to be statistical.

Short List of Inputs

General sources of information:

- (1) Telephone taps
- (2) Surveillance
- (3) Analysis of garbage
- (4) Behaviour of children in school

Standard of living by:

- (1) Food
- (2) Clothing
- (3) Shelter
- (4) Transportation

Social contacts:

- (1) Telephone - itemized record of calls
- (2) Family - marriage certificates, birth certificates, etc.
- (3) Friends, associates, etc.
- (4) Memberships in organizations
- (5) Political affiliation

The Personal Paper Trail

Personal buying habits, i.e., personal consumer preferences:

- (1) Bank accounts
- (2) Credit-card purchases

(3) "Tagged" credit-card purchases - those with a Universal Product Code

Assets:

- (1) Bank accounts
- (2) Savings accounts
- (3) Property
- (4) Business
- (5) Vehicles, etc.
- (6) Safety deposit at a bank
- (7) Stock market purchases

Liabilities:

- (1) Creditors
- (2) Enemies (see - legal)
- (3) Loans
- (4) Consumer credit

Government sources (ploys)*:

- (1) Welfare
- (2) Social Security
- (3) U.S.D.A. surplus food
- (4) Dole
- (5) Grants
- (6) Subsidies

*Principle of this ploy - the citizen will almost always make the collection of information easy if he can operate on the "free sandwich principle" of "eat now, and pay later."

Government sources (via intimidation) :

- (1) Internal Revenue Service
- (2) OSHA
- (3) Census
- (4) etc.

Other government sources - surveillance of U.S. mail.

Habit Patterns - Programming

Strengths and weaknesses:

- (1) Activities (sports, hobbies, etc.)
- (2) See "legal" (fear, anger, etc. - crime record)
- (3) Hospital records (drug sensitivities, reaction to pain, etc.)
- (4) Psychiatric records (fears, angers, disgusts, adaptability, reactions to stimuli, violence, suggestibility or hypnosis, pain, pleasure, love, and sex)

Methods of coping - of adaptability - behaviour:

- (1) Consumption of alcohol
- (2) Consumption of drugs
- (3) Entertainment
- (4) Religious factors influencing behaviour
- (5) Other methods of escaping from reality

Payment modus operandi (MO) - pay on time, etc.:

- (1) Payment of telephone bills
- (2) Energy purchases (electrical, gas,...)
- (3) Water purchases
- (4) Repayment of loans
- (5) House payments
- (6) Vehicle payments

(7) Payments on credit cards

Political sensitivity:

- (1) Beliefs
- (2) Contacts
- (3) Position
- (4) Strengths/weaknesses
- (5) Projects/activities

Legal inputs - behavioural control (Excuses for investigation, search, arrest, or use of force to modify behaviour):

- (1) Court records
- (2) Police records - NCIC
- (3) Driving record
- (4) Reports made to police
- (5) Insurance information
- (6) Anti-establishment acquaintances

National Input Information

Business sources (via I.R.S., etc.):

- (1) Prices of commodities
- (2) Sales
- (3) Investments in
 - (a) stocks/inventory
 - (b) production tools and machinery
 - (c) buildings and improvements
 - (d) the stock market

Banks and credit bureaus:

- (1) Credit information
- (2) Payment information

Miscellaneous sources:

- (1) Polls and surveys
- (2) Publications
- (3) Telephone records
- (4) Energy and utility purchases

Short List of Inputs

Outputs - create controlled situations - manipulation of the economy, hence society - control of compensation and income.

Sequence:

- (1) Allocates opportunities.
- (2) Destroys opportunities.
- (3) Controls the economic environment.
- (4) Controls the availability of raw materials.
- (5) Controls capital.
- (6) Controls bank rates.
- (7) Controls the inflation of the currency.
- (8) Controls the possession of property.
- (9) Controls industrial capacity.
- (10) Controls manufacturing.
- (11) Controls the availability of goods (commodities) .
- (12) Controls the prices of commodities.
- (13) Controls services, the labour force, etc.
- (14) Controls payments to government officials
- (15) Controls the legal functions.
- (16) Controls the personal data files - uncorrectable by the party slandered.
- (17) Controls advertising.
- (18) Controls media contact.

- (19) Controls material available for T.V. viewing.
- (20) Disengages attention from real issues.
- (21) Engages emotions.
- (22) Creates disorder, chaos, and insanity.
- (23) Controls design of more probing tax forms.
- (24) Controls surveillance.
- (25) Controls the storage of information.
- (26) Develops psychological analyses and profiles of individuals.
- (27) Controls sociological factors.
- (28) Controls health options.
- (29) Preys on weakness.
- (30) cripples strengths.
- (31) leaches wealth and substance.

Table of Strategies

Do This	To Get This
Keep the public ignorant	Less public organisation
Maintain access control	Required reaction to output (prices, sales)
Create preoccupation	Lower defences
Attack the family unit	Control the education of the young
Give less cash and more credit and dole	More self-indulgence and more data
Attack the privacy of the church	Destroy faith in this sort of government
Social conformity	Computer programming simplicity
Minimise tax protests	Maximum economic data, minimum enforcement problems
Stabilise the consent	Simplicity coefficients
Tighten control of variables	Simpler computer input data - greater predictability
Establish boundary conditions	Problem simplicity / solutions of differential and difference equations
Proper timing	Less data shift and blurring
Maximise control	Minimum resistance to control
Collapse of currency	Destroy the faith of the American people in each other

Diversion, the Primary Strategy

Experience has shown that the simplest method of securing a silent weapon and gaining control of the public is to keep the public undisciplined and ignorant of the basic system principles on the one hand, while keeping them confused, disorganised, and distracted with matters of no real importance on the other hand. This is achieved by:

- (1) Disengaging their minds; sabotaging their mental activities; providing a low-quality program of public education in mathematics, logic, systems design and economics; and discouraging technical creativity.
- (2) Engaging their emotions, increasing their self-indulgence and their indulgence in emotional and physical activities, by:
 - (a) Unrelenting emotional affronts and attacks (mental and emotional rape) by way of constant barrage of sex, violence, and wars in the media - especially the T.V. and the newspapers.
 - (b) Giving them what they desire - in excess - "junk food for thought" - and depriving them of what they really need.
- (3) Rewriting history and law and subjecting the public to the deviant creation, thus being able to shift their thinking from personal needs to highly fabricated outside priorities.

These preclude their interest in, and discovery of, the silent weapons of social automation technology. The general rule is that there is a profit in confusion; the more confusion, the more profit. Therefore, the best approach is to create problems and then offer solutions.

Diversion Summary

Media: Keep the adult public attention away from the real social issues, and captivated by matters of no real importance.

Schools: Keep the young public ignorant of real mathematics, real economics, real law, and real history.

Entertainment: Keep the public entertainment below a sixth-grade (12 year old) level.

Work: Keep the public busy, busy, busy, with no time to think; back on the farm with the other animals.

Consent, the Primary Victory

A silent weapon system operates upon data obtained from a docile public by legal (but not always lawful) force. Much information is made available to silent weapon systems programmers through the Internal Revenue Service. (See Studies in the Structure of the American Economy for an I.R.S. source list). This information consists of the enforced delivery of well-organised data contained in federal and state tax forms, collected, assembled, and submitted by slave labour provided by taxpayers and employers. Furthermore, the number of such forms submitted to the I.R.S. is a useful indicator of public consent, an important factor in strategic decision making. Other data sources are given in the Short List of Inputs.

Consent Coefficients - numerical feedback indicating victory status. Psychological basis: When the government is able to collect tax and seize private property without just compensation, it is an indication that the public is ripe for surrender and is consenting to enslavement and legal encroachment. A good and easily quantified indicator of harvest time is the number of public citizens who pay income tax despite an obvious lack of reciprocal or honest service from the government.

Amplification Energy Sources

The next step in the process of designing an Economic Amplifier is discovering the energy sources. The energy sources which support any primitive economic system are, of course, a supply of raw materials, and the consent of the people to labour and consequently assume a certain rank, position, level, or class in the social structure, i.e., to provide labour at various levels in the pecking order. Each class, in guaranteeing its own level of income, controls the class immediately below it, hence preserves the class structure. This provides stability and security, but also government from the top. As time goes on and communication and education improve, the lower-class elements of the social labour structure become knowledgeable and envious of the good things that the upper-class members have. They also begin to attain a knowledge of energy systems and the ability to enforce their rise through the class structure. This threatens the sovereignty of the Elite.

If this rise of the lower classes can be postponed long enough, the Elite can achieve energy dominance, and labour by consent no longer will hold a position of an essential energy source. Until such energy dominance is absolutely established, the consent of people to labour and let others handle their affairs must be taken into consideration, since failure to do so could cause the people to interfere in the final transfer of energy sources to the control of the Elite. It is essential to recognise that at this time, public consent is still an essential key to the release of energy in the process of economic amplification. Therefore, consent as an energy release mechanism will now be considered.

Logistics

The successful application of a strategy requires a careful study of inputs, outputs, the strategy connecting the inputs and the outputs, and the available energy sources to fuel the strategy. This study is called "Logistics". A logistical problem is studied at the elementary level first, and then levels of greater complexity are studied as a synthesis of elementary factors. This means that a given system is analysed, i.e., broken down into its sub-systems, and these in turn are analysed, until by this process, one arrives at the logistical "atom," the individual.

The Artificial Womb

From the time a person leaves his mother's womb, his every effort is directed towards building, maintaining, and withdrawing into artificial wombs, various sorts of substitute protective devices or shells. The objective of these artificial wombs is to provide a stable environment for both stable and unstable activity; to provide a shelter for the evolutionary processes of growth and maturity - i.e., survival; to provide security for freedom and to provide defensive protection for offensive activity. This is equally true of both the general public and the Elite. However, there is a definite difference in the way each of these classes go about the solution of problems.

The Political Structure of a Nation - Dependency

The primary reason why the individual citizens of a country create a political structure is a subconscious wish or desire to perpetuate their own dependency relationship of childhood. Simply put, they want a human god to eliminate all risk from their life, pat them on the head, kiss their bruises, put a chicken on every dinner table, clothe their bodies, tuck them into bed at night, and tell them that everything will be all right when they wake up in the morning. This public demand is incredible, so the human god, the politician, meets incredibility with incredibility by promising the world and delivering nothing. So who is the bigger liar? The public? or The "godfather"? This public behaviour is surrender born of fear, laziness, and expediency. It is the basis of the welfare state as a strategic weapon, useful against a disgusting public.

Action / Offence

Most people want to be able to subdue and/or kill other human beings who disturb their daily lives, but they do not want to have to cope with the moral and religious issues which such an overt act on their part might raise. Therefore, they assign the dirty work to others (including their own children) so as to keep the blood off their hands. They rave about the humane treatment of animals and then sit down to a delicious hamburger from a whitewashed slaughterhouse down the street and out of sight. But even more hypocritical, they pay taxes to finance a professional association of hit men collectively called politicians, and then complain about corruption in

government.

Responsibility

Again, most people want to be free to do the things (to explore, etc.) but they are afraid of failing. The fear of failure is manifested in irresponsibility, and especially in delegating those personal responsibilities to others where success is uncertain or carries possible or created liabilities (law) which the person is not prepared to accept. They want authority (root word - "author"), but they will not accept responsibility or liability. So they hire politicians to face reality for them.

Summary

The people hire the politicians so that the people can:

- (1) Obtain security without managing it.
- (2) Obtain action without thinking about it.
- (3) Inflict theft, injury, and death upon others without having to contemplate either life or death.
- (4) Avoid responsibility for their own intentions.
- (5) Obtain the benefits of reality and science without exerting themselves or learning either of these things.

They give the politicians the power to create and manage a war machine:

- (1) Provide for the survival of the nation/womb.
- (2) Prevent encroachment of anything upon the nation/womb.
- (3) Destroy the enemy who threatens the nation/womb.
- (4) For the sake of stability of the nation/womb, destroy those citizens of their own country who do not conform.

Politicians hold many quasi-military jobs, the lowest being the police who are soldiers, the attorneys and C.P.A.s next who are spies and saboteurs (licensed), and the judges who shout orders and run the closed union military shop for whatever the market will bear. The generals are industrialists. The "presidential" level of commander-in-chief is shared by the international bankers. The people know that they have created this farce and financed it with their own taxes (consent), but they would rather knuckle under than be the hypocrite. Thus, a nation becomes divided into two very distinct parts, a docile sub-nation [great silent majority] and a political sub-nation. The political sub-nation remains attached to the docile sub-nation, tolerates it, and leaches its substance until it grows strong enough to detach itself and then devour its parent.

System Analysis

In order to make meaningful computerized economic decisions about war, the primary economic flywheel, it is necessary to assign concrete logistical values to each element of the war structure - personnel and material alike. This process begins with a clear and candid description of the subsystems of such a structure.

The Draft (military service)

Few efforts of human behaviour modification are more remarkable or more effective than that of the socio-military institution known as the draft. A primary purpose of a draft or other such institution is to instil, by intimidation, in the young males of a society the uncritical conviction that the government is omnipotent. He is soon taught that a prayer is slow to reverse what a bullet can do in an instant. Thus, a man trained in a religious environment for eighteen years of his life can, by this instrument of the government, be broken down, be purged of his fantasies and delusions in a matter of mere months. Once that conviction is instilled, all else becomes easy to instil.

Even more interesting is the process by which a young man's parents, who purportedly love him, can be induced to send him off to war to his death. Although the scope of this work will not allow this matter to be expanded in full detail, nevertheless, a coarse overview will be possible and can serve to reveal those factors which must be included in some numerical form in a computer analysis of social and war systems. We begin with a tentative definition of the draft. The draft (selective service, etc.) is an institution of compulsory collective sacrifice and slavery, devised by the middle-aged and elderly for the purpose of pressing the young into doing the public dirty work. It further serves to make the youth as guilty as the elders, thus making criticism of the elders by the youth less likely (Generational Stabilizer). It is marketed and sold to the public under the label of "patriotic = national" service.

Once a candid economic definition of the draft is achieved, that definition is used to outline the boundaries of a structure called a Human Value System, which in turn is translated into the terms of game theory. The value of such a slave labourer is given in a Table of Human Values, a table broken down into categories by intellect, experience, post-service job demand, etc. Some of these categories are ordinary and can be tentatively evaluated in terms of the value of certain jobs for which a known fee exists. Some jobs are harder to value because they are unique to the demands of social subversion, for an extreme example: the value of a mother's instruction to her daughter, causing that daughter to put certain behavioural demands upon a future husband ten or fifteen years hence; thus, by suppressing his resistance to a perversion of a government, making it easier for a banking cartel to buy the State of New York in, say, twenty years.

Such a problem leans heavily upon the observations and data of wartime espionage and many types of psychological testing. But crude mathematical models (algorithms, etc.) can be devised, if not to predict, at least to predetermine these events with maximum certainty. What does not exist by natural cooperation is thus enhanced by calculated compulsion. Human beings are machines, levers which may be grasped and turned, and there is little real difference between automating a society and automating a shoe factory. These derived values are variable. (It is necessary to use a current Table of Human Values for computer analysis). These values are given in true measure rather than U.S. dollars, since the latter is unstable, being presently inflated beyond the production of national goods and services so as to give the economy a false kinetic energy ("paper" inductance). The silver value is stable, it being possible to buy the same amount with a gram of silver today as it could be bought in 1920. Human value measured in silver units changes slightly due to changes in production technology.

Factor 1 - Enforcement

As in every social system approach, stability is achieved only by understanding and accounting for human nature (action/reaction patterns). A failure to do so can be, and usually is, disastrous. As in other human social schemes, one form or another of intimidation (or incentive) is essential to the success of the draft. Physical principles of action and reaction must be applied to both internal and external subsystems. To secure the draft, individual brainwashing/programming and both the family unit and the peer group must be engaged and brought under control.

Factor 2 - Father

The man of the household must be housebroken to ensure that junior will grow up with the right social training and attitudes. The advertising media, etc., are engaged to see to it that father-to-be is pussy-whipped before or by the time he is married. He is taught that he either conforms to the social notch cut out for him or his sex life will be hobbled and his tender companionship will be zero. He is made to see that women demand security more than logical, principled, or honourable behaviour. By the time his son must go to war, father (with jelly for a backbone) will slam a gun into junior's hand before father will risk the censure of his peers, or make a hypocrite of himself by crossing the investment he has in his own personal opinion or self-esteem. Junior will go to war or father will be embarrassed. So junior will go to war, the true purpose notwithstanding.

Factor 3 - Mother

The female element of human society is ruled by emotion first and logic second. In the battle between logic and imagination, imagination always wins, fantasy prevails, maternal instinct dominates so that the child comes first and the future comes second. A woman with a newborn baby is too starry-eyed to see her child as a wealthy man's cannon fodder or a cheap source of slave labour. A woman must, however, be conditioned to accept the transition to "reality" when it comes, or even sooner. As the transition becomes more difficult to manage, the family unit must be carefully disintegrated, and state-controlled public education and state-operated child-care centres must become more common and legally enforced so as to begin the detachment of the child from the mother and father at an earlier age. Inoculation of behavioural drugs [Ritalin] can speed the transition for the child (mandatory). Caution: A woman's impulsive anger can override her fear. An irate woman's power must never be underestimated, and her power over a pussy-whipped husband must likewise never be underestimated. It got women the vote in 1920.

Factor 4 - Junior

The emotional pressure for self-preservation during the time of war and the self-serving attitude of the common herd that have an option to avoid the battlefield - if junior can be persuaded to go - is all of the pressure finally necessary to propel Johnny off to war. Their quiet blackmailing of him are the threats: "No sacrifice, no friends; no glory, no girlfriends".

Factor 5 - Sister

And what about junior's sister? She is given all the good things of life by her father, and taught to expect the same from her future husband regardless of the price.

Factor 6 - Cattle

Those who will not use their brains are no better off than those who have no brains, and so this mindless school of jelly-fish, father, mother, son, and daughter, become useful beasts of burden or trainers of the same.

Please note that the section of text above, shown in blue, is not an expression of my own personal opinion, but comes from an anonymous document. However, sections of it describe clearly what is without question being applied to the people in many nations of the world today, so it is difficult to discount any of what is said. At the present time, economic warfare is most definitely being waged against normal, innocent people in most countries of the world, and there is every appearance that a major offensive against us is in progress, instigated and orchestrated by the few "Elite" New World Order people who have already caused so much unnecessary death and suffering.

So who are the New World Order people whose aims are to disadvantage and destroy ordinary people through their "Quiet War"? Well, there are several major branches of them, each presenting a benign and caring face to the world and most with large numbers of sincere adherents who have not the slightest idea of the aims and policies of the few people at the top who actually direct and control those organisations. While most operations are carried out in complete secrecy, the most visible people in the ruling bodies form the Bilderberg Group. This comprises 13 Freemasons, 13 Vatican representatives, and 13 Black Mobility people. These 39 people of the Bilderberg Group have offices in Switzerland (the only European country which was never invaded or bombed during World War One or World War Two) answer to the 13 people who form the Policy Group, which in turn answers to the 9 people of the Round Table. The individuals concerned are typically, powerful financiers, industrialists, statesmen and intellectuals.

The power and influence of these people should not be underestimated. They have infiltrated and subverted the US Congress and Senate, rendering ineffective the checks and balances intended when the Constitution was originally set up. At 3:30 am on Saturday 4th August 1990, a minority of US Senators, maybe ten at most, passed the Senate Intelligence Authorisation Act for Fiscal Year 1991 (S.B. 2834). This bill is not widely known. It was brought to a vote by Senator Sam Nunn in the dead of night when the opposition was gone. It effectively transfers most authority of the United States Government directly into the hands of the President. It gives him the power to initiate war, appropriate public funds, define foreign policy goals, and decide what is important to US national security. It gives the President the power to initiate covert actions (a power never before given to any President) and prevents Congress from stopping the President's initiation of covert actions. It allows the President to use any federal "departments, agencies or entities" to operate or finance a covert operation. It empowers the President to use any other nation or private contractor or person to fund or operate a covert action. It redefines covert actions as operations "necessary to support foreign policy objectives of the United States" which is a definition which is so broad and vague as to be essentially unlimited. It, for the first time ever, officially claims the right of the United States to interfere secretly in the internal "political, economic or military affairs" of other countries in direct and flagrant violation of international law. It requires the President to prepare and deliver a written finding to the Intelligence committees of Congress, but it allows the President to omit "extremely sensitive matters" and authorises the President to claim Executive Privilege if Congress asks too many questions.

Further, there are no penalties in the Bill for violating any of its provisions, including the provision for requiring a finding. That Bill effectively handed all the powers of government to the President, effectively making him the sole ruler of the USA without accountability to anyone.

I suggest that the New World Order people have sufficient influence to ensure that every candidate for President of the USA is a member of the New World Order. That way, they are assured that they have full control of the whole of the USA at all times no matter what the outcome of the "democratic" voting. It is said that Henry Ford stated that customers could have a new Model T car in any colour they wanted, provided that the colour was black. Well, the equivalent is now in place, where the American people can have any President they want, provided that the President is a New World Order man. This information is not even considered secret any more. For example:

"... Some even believe we (the Rockefellers) are part of a secret cabal working against the best interests of the United States, characterising my family and me as 'internationalists' and of conspiring with others around the world to build a more integrated global political and economic structure - one world, if you will. If that's the charge, I stand guilty, and I am proud of it."

—David Rockefeller, *Memoirs* (2002, Random House publishers), page 405

It should not be imagined that the events in the USA have no effect elsewhere. The New World Order people are working on expanding the EU, blurring the identities of individual countries through legislation, reducing the effects of borders and generally moving towards a single entity with one central government. They are actually aimed at producing ten unified areas of the world which they then intend to amalgamate into a single world state governed by them. This is judged to be easier if there are fewer people, so one of their major aims is to reduce the number of people living at the present time. They also need the remaining people to be wholly dependent on them for the essentials of life, which is one reason why they oppose the introduction of any free-energy device, since having an independent source of power would put people outside their direct control and so will not be allowed.

If the video has not been wiped off the web, then the video from Walter Burien:

<http://video.google.com/videoplay?docid=6703413885850200097&hl=en> demonstrates the double-bookkeeping which is being operated by the US government where the US people are being told that they are in debt when in fact, "public" funds are massively in profit. In Britain, and probably in many other places in the world, nearly 80% of all earned income is taken away from ordinary people. Natural rights are being done away with and replaced by "privileges" which can be revoked. It has been remarked with considerable insight, that "in the old days, slaves were housed and fed, but today, those slaves are expected to house and feed themselves". For a simple straightforward explanation of how this is done, try <http://www.yourstrawman.com>.

Patrick Kelly

<http://www.free-energy-info.tuks.nl/>

Chapter 16: Questions and Answers

This is a fast-moving field of research and development, and one where a single person working alone, can outperform research establishments with unlimited budgets and many staff members. If you believe that the answers given below are inadequate or incorrect, then please tell me as this is definitely a learning process for all of us.

Topic: What To Build

I am regularly asked to recommend a device for someone to build. This is an impossible task as the person asking never says in which part of the world he lives, how much money could be used in the project, what tools are to hand, what workshop space (if any) is available, what local supplies of materials is like, whether the home is in a city or an isolated remote place, local assets like a shoreline, a fast-flowing stream or lots of sunshine all year round, how much ground space is available, what his skills are, etc. etc.

What should be realised is that a small group of friends can achieve a great deal. If one person likes working with engines and another can fix television sets and a third can weld, or ... whatever. By working together, they can achieve a great deal and benefit both themselves and their friends, not to mention having a good deal of fun in the process and ending up with a great sense of achievement.

We should not dismiss the various forms of renewable energy such as wave power, RAM pump, solar panels, wind power, biomass and the like. Granted, they do not always provide power all of the time, but if they provide most of the power you need for most of the time you need it, then that can be a considerable saving on your present power costs, so you should consider the devices covered in chapter 14. One possibility is to use a RAM pump with a fast-flowing stream, to pump water up into a water tower over night, and use the tank of water to power a turbine driving an electrical generator when needed.

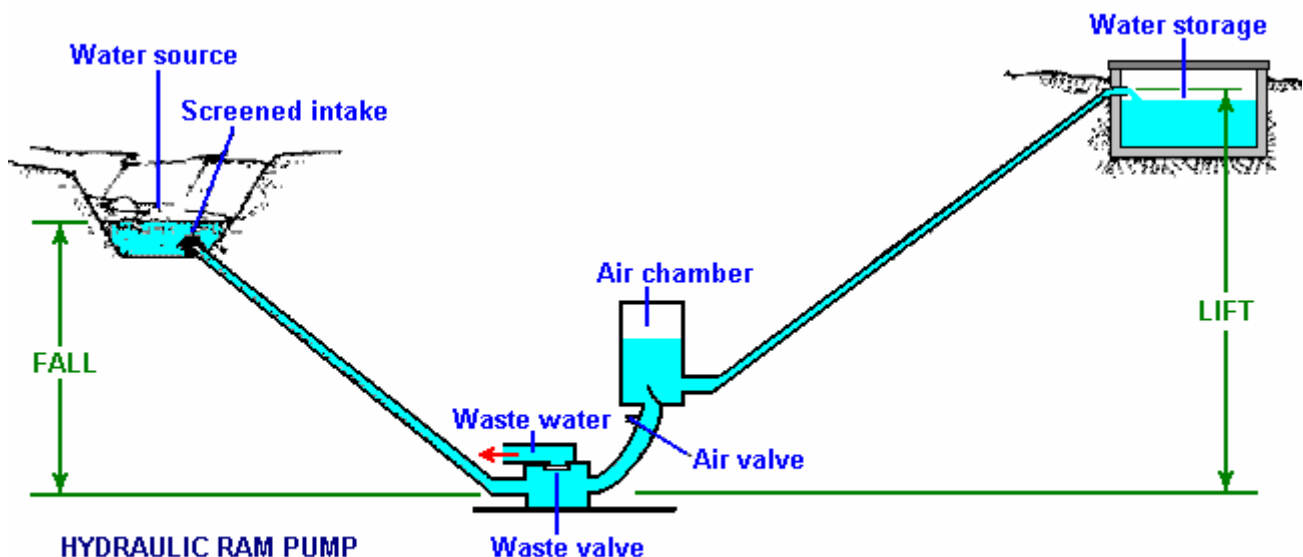
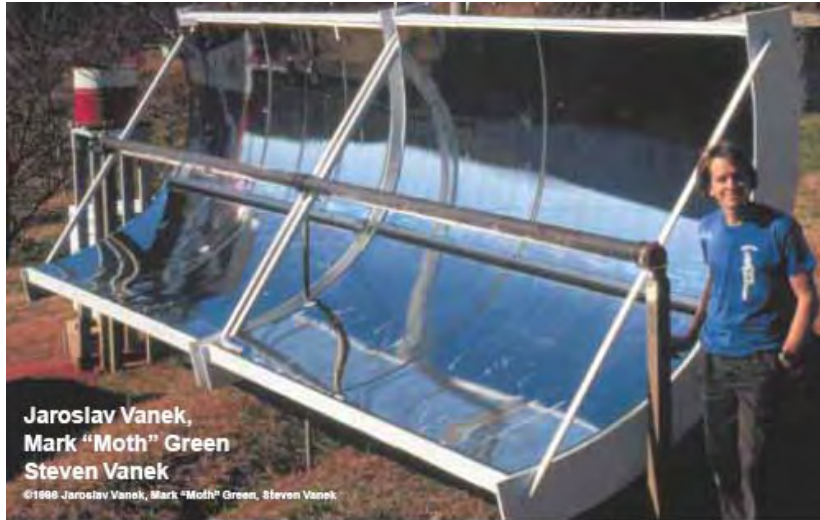

Diagram from: www.thefarm.org/charities/i4at/lib2/hydrpump.htm

If you have the space and the sunshine, then a parabolic mirror can focus the sunshine, produce steam and drive a generator, a mechanical drive, a pump, or whatever else is needed.



Above: Steven Vanek with his machine which uses solar thermal energy to make ice.

If you are lucky enough to have access to a small section of coastline, then using either wave power or tidal power gives a major amount of power each year with even a simple low-tech construction like this:

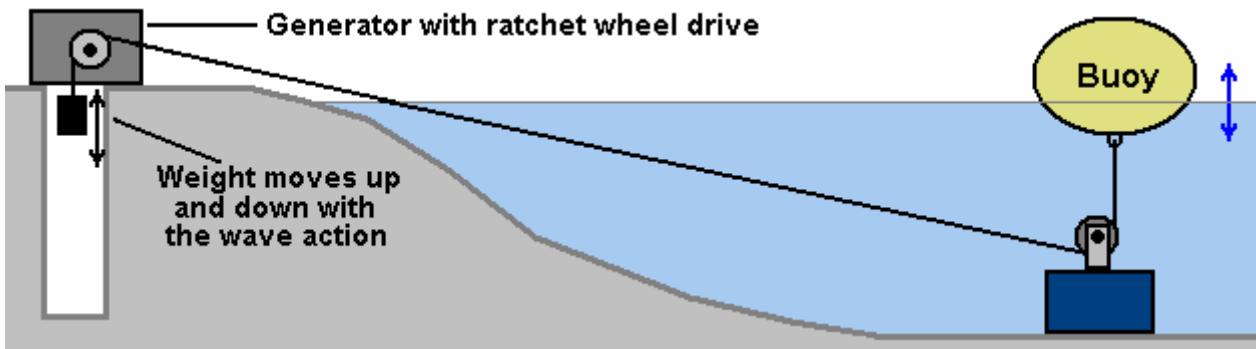

It is not necessary to "go for broke" and aim at a device which will completely do away with your power needs for evermore. Initially, it can be a major step forward to produce a device which reduces your energy bill by a good deal and later on, progress to an additional system which makes you fully independent of others. For example, it is perfectly possible to drive a RotoVerter (chapter 2) with a solar panel:



The output is much more powerful than the input from the solar panel and can be used to run power tools, charge batteries or perform other useful tasks at effectively no cost at all.

The Frenette heater (chapter 14) does give significant heat output for the modest power input needed to spin the central shaft. It is a simple construction well within the capabilities of most people, and it could be driven by a solar panel if you live in an area where it is cold and sunny. As the array of discs spin, the vegetable oil inside the cylinder gets heated and pushed upwards and outwards, flowing through the radiator tubing, heating the house:

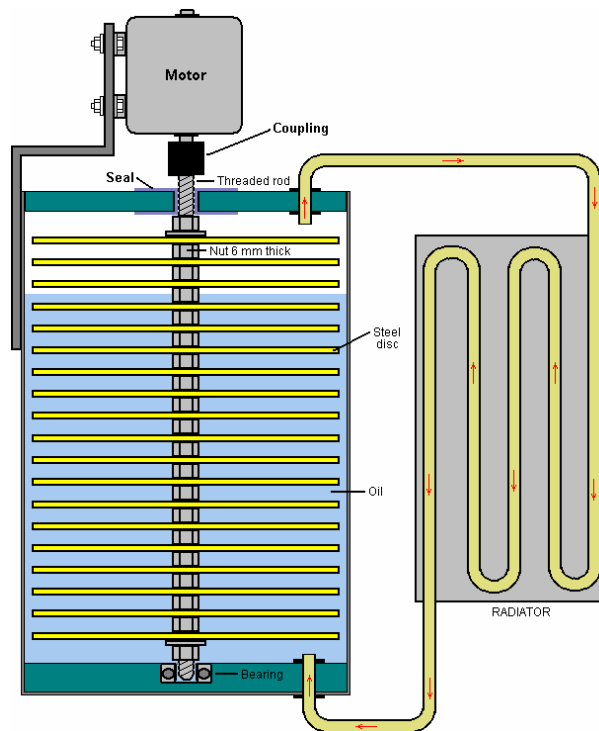

There are many high-performance alternatives which need special skills or equipment to build, but these can be found and constructed by those people who have above average skills and workshop facilities.

Devices which can provide power at any time, and at any location, include running a standard electrical generator with water as the only fuel (chapter 10). Strictly speaking, the generator runs on energy drawn from the environment and not on water.



While it is perfectly possible to run this type of generator with water as what appears to be the only fuel, it must be realised that a generator of this type produces noise which will not be acceptable for neighbours if the user lives in a congested city environment. Admittedly, a suitable housing with many carpet-covered baffles would allow good air flow and cooling while reducing the noise to very low levels, but generally speaking, this is a solution for people who like working with internal combustion engines and who live some distance away from other people.

The Adams motor (chapter 2) when accurately built, can produce eight times as much output power as the power needed to make it operate. This is a good energy gain and the device is not difficult to build:

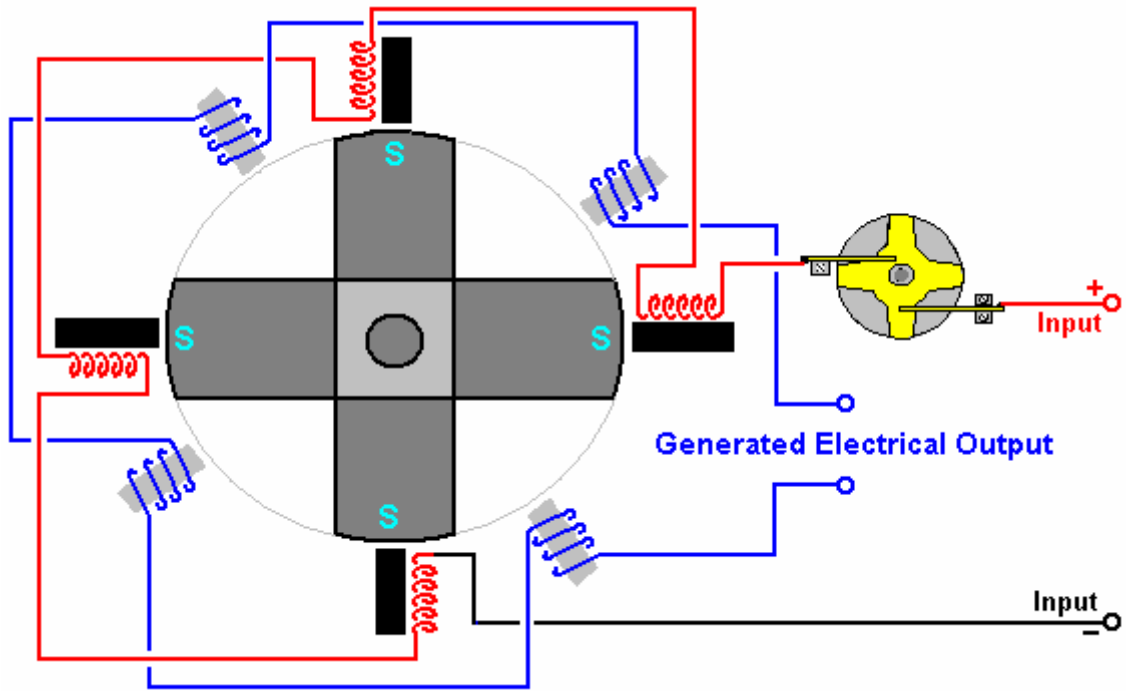

Another device which is not hard to build is the Charles Flynn magnet motor (chapter 1):

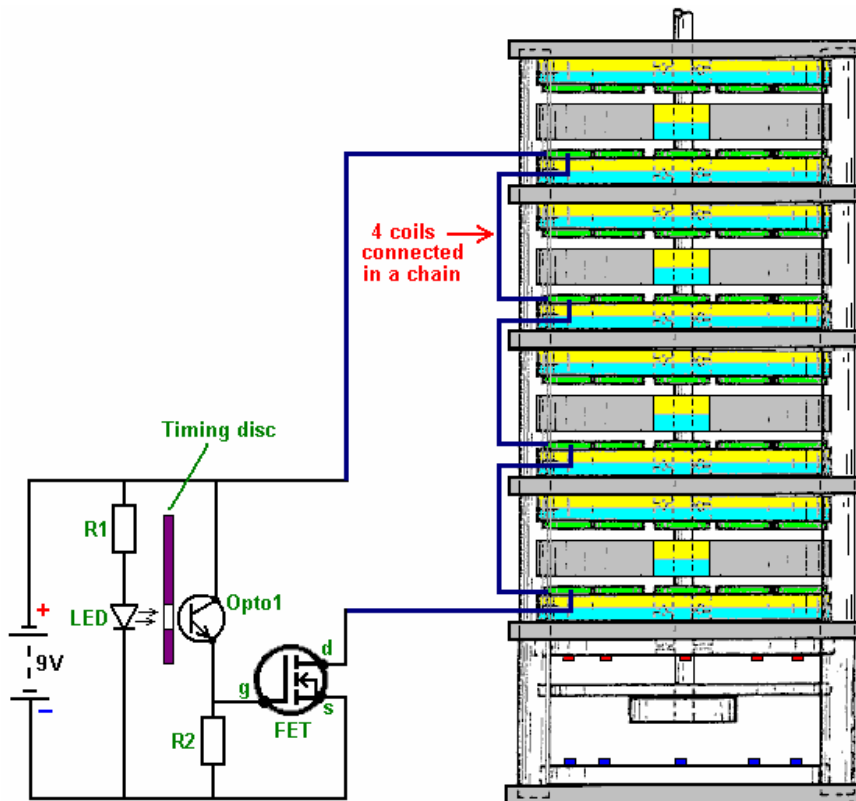

And if the electronics used to drive it is something which you have not come across before, then chapter 12 shows you how to understand and make these kinds of electronic circuits. A friend who is familiar with circuitry might help. A motor of this type can be made to produce any amount of power. Flynn's prototype ran at 20,000 rpm driven by just an ordinary 9-Volt dry cell battery. A big advantage with a motor like this is that you understand exactly how it works, and as you built it in the first place, if it ever breaks down, then you can fix it.

Another possible simple project is the Kundel magnet motor (chapter 1). Using just a simple rocking arm movement, powerful shaft rotation is produced. That rotation can be used as a mechanical drive, or to spin magnets past wire coils to produce electricity:

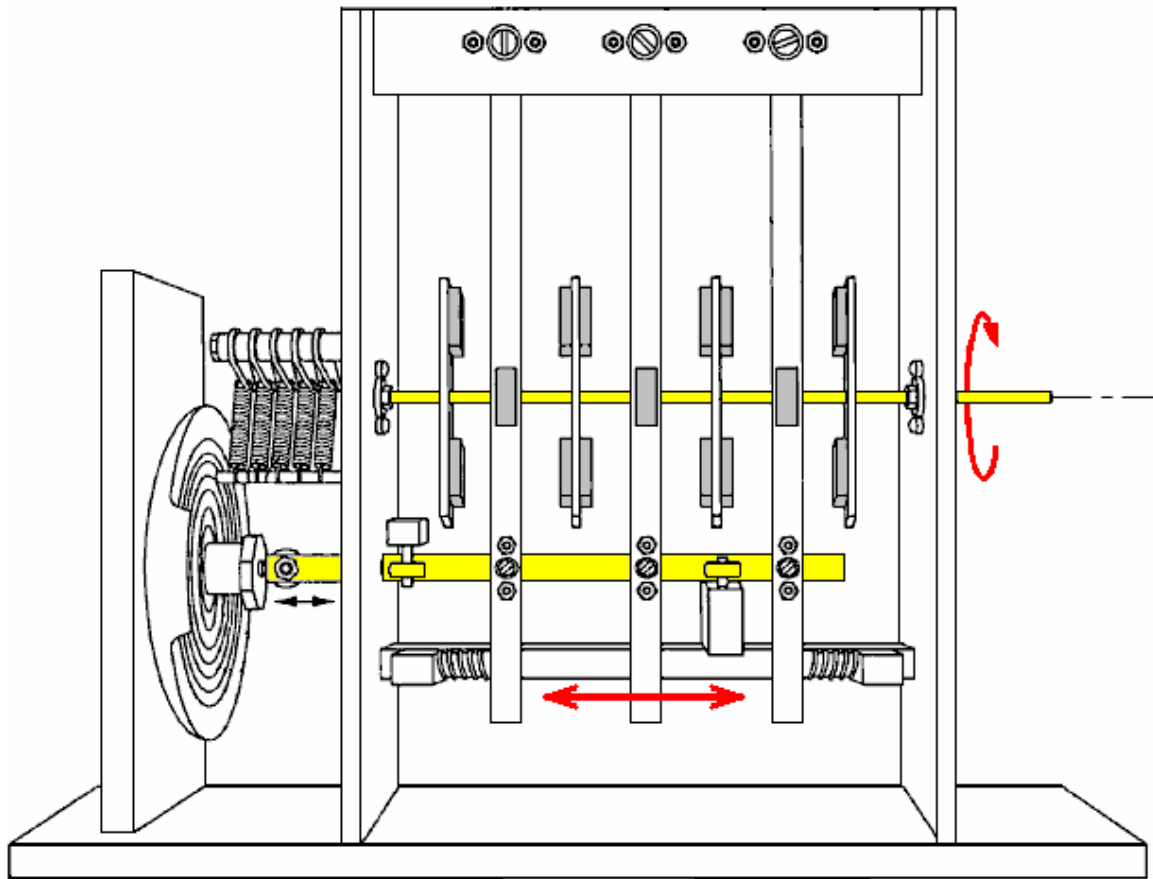

This motor operates by moving the magnets on the rocker arms, away from the rotor magnets when they would oppose the rotation and closer to the magnets on the next rotor which would promote the rotation. The rate at which the loudspeaker cone electromagnet is driven by an electronic circuit, controls the speed of the motor.

Another device which can supply extra power is John Bedini's pulsed flywheel (chapter 4). The objective is to apply a pulsed drive to a heavy flywheel. Each pulse acts as an impact, providing excess power to the flywheel. John had a small one of these running in his workshop for more than three years.

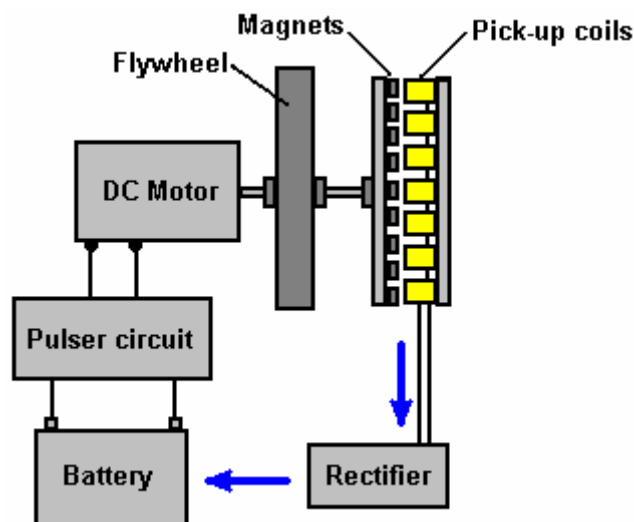

The DC motor is pulsed by a simple electronic circuit and the flywheel spins permanent magnets past a circle of coils of wire. The voltage generated in the coils is converted with four diodes to produce a pulsing DC voltage which can charge the battery and do additional work as well.

The output from a device of this nature depends on the size of the device. Jim Watson built one which was twelve feet high and he got 12 kilowatts of excess power from it. Obviously, I would not suggest that you build one as big as that, but perhaps one of say, three feet in diameter might have a very useful output. You have the option of wiring the coils in a chain in order to have a higher voltage output. If you do that, then have the same number of coils as permanent magnets so that they all pulse at the same moment. Alternatively, if you want to use magnets mounted with every second one having a different pole facing outwards and still have the coils in a chain, then have twice as many magnets as coils.

A similar wheel-pulsing method is used in the water-jet generator (chapter 4) which looks like a very simple thing to implement. Here, a jet of water provides a jerky drive to a wheel when the jet of water hits paddles attached to the rim of a wheel, geared through to an electrical generator.



<http://www.youtube.com/watch?gl=GB&hl=en-GB&v=zlinM1wAI5U> has a video showing this arrangement in operation. If you decide to build it then please arrange for an external change-over switch located in a dry area outside the box for switching the pump over from the mains supply to the output from the generator as that is not something which should be done with a plug and socket in a wet area.

One of the most straightforward projects would be replicating Chas Campbell's flywheel system. Perhaps an arrangement like this:

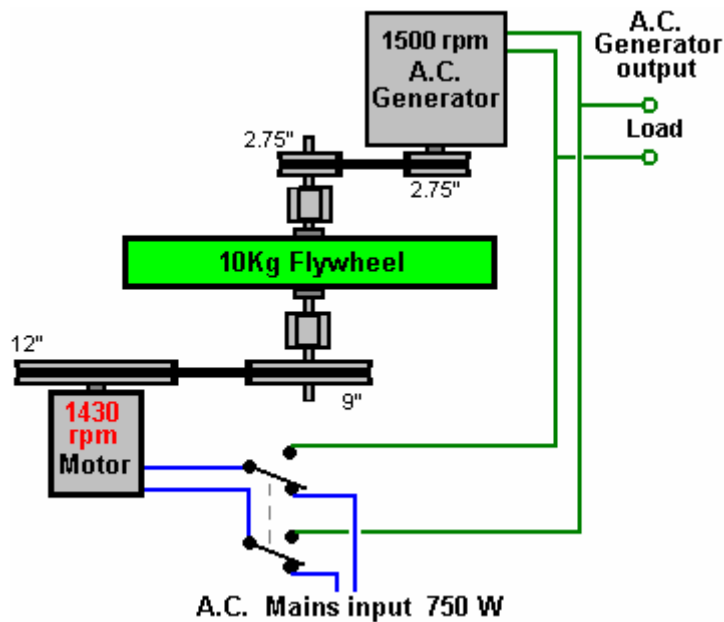

Or if you prefer, an arrangement where there is more than one flywheel, again, keeping the flywheel shaft input drive pulley larger than the output pulley on that shaft.

Moving to a somewhat more difficult, but quite possible project. Dr Scott Cramton's version of Dave Lawton's electrolyser (chapter 10) is capable of generating a serious HHO gas output of 6 litres per minute of high quality gas for a very small power input.

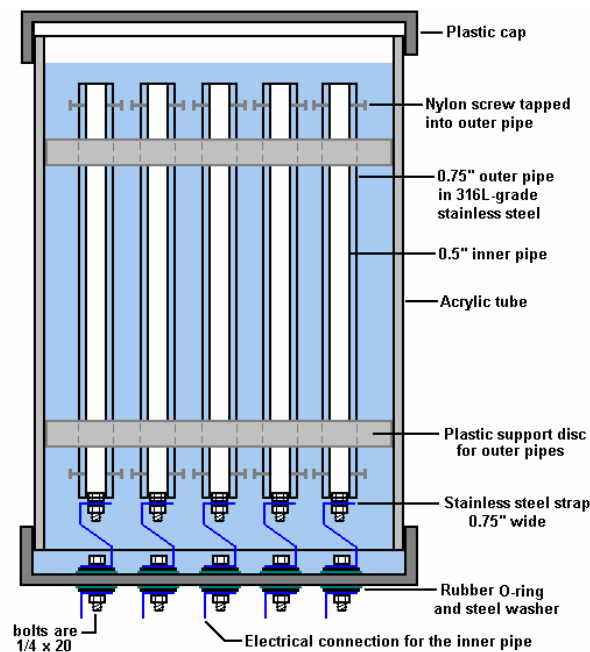

This project needs patience as each of the tubes needs to be filed down so that they all resonate at the same frequency. Some minor electronics needs to be built and the pipes either conditioned or alternatively, insulated. The gas output can be used for heating, welding, cutting, cooking, boosting a vehicle or running a generator on water.

If you decide to start some project, then whatever project you pick, the most important thing is that it should be one which interests you and building it is fun. You will notice that the projects suggested here generally have moving parts which make it easy to see how the device is operating. The more difficult projects where there are no moving parts and meters need to be used can be left for a later time. If you decide to build something, then let me wish you good luck with your project.

A Matter of Opinion

This eBook is just a sharing of the information which I have come across during some years of investigating devices which are loosely described as being "free-energy" devices – a description which some people dislike because it costs money to construct or purchase a device which can produce useful work, even if the device appears to be self-powered. I am not an expert in the subject and so I have attempted to present the information in a direct and factual way.

However, I am regularly asked for my opinion on various devices and which one is best suited to some particular person, so, reluctantly, I will share some personal opinions on a selection of devices. Please understand that the following is just my opinion and could very well be completely wrong. Your level of interest in any particular device depends on your background and whether you are interested in a small device which proves that free-energy exists and can be harnessed, even though the output level is very small. Or if your objective is to obtain a device which can reduce your expenses. Or if you just want to investigate the subject for the sake of general interest. So, we have a wide range of different devices and a range of possible interests, so an attempt has been made to divide the devices into categories based on ease of construction and the output power levels produced by each device.

Please bear in mind that there has been a very high level of opposition to any of this type of information becoming well-known and so, information on each device tends to be limited, and while half a dozen devices may well be offered for sale in 2013, at the present time few are commercially available, leaving you to build your own or get a friend to join with you in the construction, which is actually a very good idea as small groups of people can have a very wide range of skills.

Devices Which are the Easiest to Build

[The Magnetic Frame of Lawrence Tseung](#) (chapter 3)

[The Transformers of Thane Heins](#) (chapter 3)

[Stephan Leben's adaptation of the Flynn Magnetic Frame](#) (chapter 3)

These three devices have no moving parts and their performance has to be determined by measurements of the input power and the output power. They all operate by passing a fluctuating magnetic field through a frame, which is typically made from thin strips of laminated steel. These devices are limited in their power levels by the amount of magnetic flux which can be carried by their magnetic frames, and to a much lesser extent, by the maximum current which can be carried by the coil windings placed on those frames. Once the core reaches magnetic saturation, applying a stronger magnetic field to it has no effect at all and just wastes the additional power. So, in order to get any form of powerful output, the magnetic frame or core needs to have a high magnetic capacity, which typically means that the frame has to be big, which in turn, means it will probably be heavy and it may be expensive. Using specialised materials for the core could make a major difference, but most constructors will not have access to any of these nanocrystalline materials.

When properly constructed and operated, these devices can certainly show you that $COP > 1$ is definitely possible. However, as the results are based on measurements, it is generally difficult to convince anyone else as many people will presume that you are operating a hoax as they have always been taught that any such operation is "impossible" as there is no such thing as "a free lunch". If you do want to comment on the input and output power levels, then be sure to measure the DC voltage and the DC current on both the input and the output as it will be argued that any form of waveform will give measurement errors.

The most convincing thing is if the device supplies it's own input power as well as supplying some additional item, even a single LED. Where the COP is greater than 1, this should be possible, but to keep the device operating steadily, I suggest that you use a voltage-stabilised circuit to supply the input power as that prevents a runaway situation where increased output power produces increased input power and a positive feedback is created which could lead to the almost instant destruction of circuit components which have been driven well past their rated values.

[Clemente Figuera's Split Transformer](#) (chapter 3)

The Figuera split transformer is exceptional in that it is completely free of the usual crippling Lenz-Law effects and it has the capability of outputs of several kilowatts. The details have been lost for more than a century and only recently been made available, so considerable experimentation is needed but the possible results are spectacular. If electronics does not appeal to you, then using mechanical switching like Clemente did, is a perfectly feasible method of construction. If you want to supply the input power from part of the output, then I would recommend using a stabilised power supply to ensure that only your chosen voltage is supplied as input power.

[Carlos Benitez's Generator](#) (chapter 5)

This spectacular design is capable of kilowatts of continuous excess power through the use of just two batteries. The design documentation explains how to calculate the size of the components and the mechanical switching is only used very occasionally and so can be replaced with simple solid-state switching to avoid mechanical construction.

[Lawrence Tseung's "FLEET" Toroid](#) (chapter 5)

This is a very easy device to construct and use, but it's output power is very small. Demonstration kits are due to be offered for sale quite soon. Developments are in hand and I have been told of a version which can run at six kilowatts. The presently known versions appeal enormously to many people who are intrigued that an almost totally exhausted single dry cell battery with far less than one volt, can charge a 6-volt battery or light LEDs for long periods. While this is definitely a 'fun' device, it is unlikely to convince anyone that 'free-energy' exists. A one-kilowatt version would be a very different matter. I have confirmed $COP > 1$ operation by using one 12V battery to charge another, swapping the batteries over and repeating the process. The result was that both batteries ended up with considerably more genuinely useable power.

[The Aerial Plate System](#) (chapter 7)

This is also very easy to construct and being a modular system it has the advantage that it can easily be expanded to give substantial power outputs. This device is based on a Nikola Tesla invention and it has nothing to do with radio transmissions as it picks up ambient energy from the environment. While it can be used to charge batteries, it might also be used for direct power supply if suitable control circuitry is constructed for it. It needs a very high aerial and an extremely good earth in order to perform properly.

[John Bedini's Simple School Girl Battery-pulser](#) (chapter 6)

[Alexkor's Solid-state battery-pulsers](#) (chapter 6)

These devices can be very effective in what they do but they are not likely to convince anyone of COP>1 operation. Ron Pugh of Canada has achieved COP=13 with his implementation of the Bedini device running on 24-volts. It is difficult to demonstrate the actual performance as batteries are capable of getting a false "surface charge" which shows a high voltage but does not indicate a genuinely high level of recharging for that battery as the voltage will drop rapidly when driving a load. The only reliable way to assess the state of charge of a battery is to make it drive a load and observe how long it can sustain that load. The most recent, very-simple, solid-state Alexkor circuit has a COP=12 performance.

The Bedini pulse-charger has an impressive spinning wheel or rotor, but it's usefulness is severely limited as it can only charge batteries which are not being used to power a load. That means that it's charged batteries are only occasionally available, or two sets of batteries are needed, one for use while the other set is being charged. Ordinary batteries are not all that useful as their life is severely shortened if they are discharged in less than a 20-hour period.

[Joseph Newman's Motor](#) (chapter 11)

This is a particularly easy device to build and one which had an experienced technician considerably bothered by it's performance (as shown in Joseph Newman's book which can be downloaded from <http://www.free-energy-info.tuks.nl/>) as he could not explain how it could possibly perform as it does. However, the amount of power from any reasonably-sized replication will be low.

[Internal Combustion Engine Boosters](#) (chapter 10)

Simple boosters such as the "Smack's Booster" can be built quite easily and they can improve the burn quality of the standard fuel used in an internal combustion engine very considerably, reducing the unwanted emissions and raising the mpg figures by a typical amount of 20% to 40%. While building and using a booster, the actual installing of one in a vehicle does require some basic vehicle knowledge and a few basic tools.

[Dietmar Hohl's Magnet Motor](#) (chapter 1)

This motor has been replicated and proven to work. Given a little care when constructing it and angling the stator magnets as shown gives a considerable improvement in the power available. However, as shown with just one V-set of magnets and one cylinder of stator magnets, the power is not that great although it demonstrates conclusively that permanent magnets can be used to provide power and demonstrate "perpetual motion" which is so much feared by "scientists" because it shows that their pet theories are, at best, incomplete and at worst, completely wrong. To get some power from this motor design, you need to use a larger diameter drum with two, three, four or five sets of V-magnets around it's circumference, and possibly more than one set of magnets along the length of the drum. The number of magnets involved in even the minimum arrangement is quite large.

[Ben Teal's Motor](#) (chapter 1)

This motor design is very, very simple and the first version was built using wood and it proved to be very effective, having a two-inch (50 mm) diameter drive shaft. Ben found that he was unable to slow or stop the motor by grasping the drive shaft as the motor was just too powerful. This motor has not been shown to be COP>1 but I wouldn't be surprised if is.

[Don Kelly's Magnetic Motor](#) (chapter 1)

I have never heard of anybody building this design. It has the potential for serious COP>1 operation as the driving power comes from the magnets and only a small amount of power is needed for the motors to move the stator magnets. I see synchronising the motors as being a potential problem and so would suggest that using only one motor to drive all of the stators as being a sensible option. The motor speed during start-up can be controlled manually with a DC Motor Speed Controller and then the setting just left when it is running at full speed. It could be used to drive sets of magnets between coils to generate electricity and that output boosted substantially further with the coil-shortening method described in chapter 2.

[Stephen Kundel's Magnetic Motor](#) (chapter 1)

This is a very simple and direct method of getting permanent magnets to provide continuous drive with just a very low electrical input used to change the location of the stator magnets in much the same way as in Don Kelly's motor design. The movement is very simple as it is just a rocking movement, driven by the mechanism used in a loudspeaker. As there can be as many sets of rotor and stator magnets on any drive shaft, the power of this design can be substantial.

[Raoul Hatem](#) (chapter 2)

This arrangement of magnets and generators is expensive as each generator uses thirty-six powerful magnets to give good magnetic coupling between the drive motor and every generator. Some people believe that this design cannot possibly be COP>1 as the motor drives each of the generators (although most are driven indirectly). I don't know if that is correct or not, but there is the possibility that as the motor creates a rotating magnetic field

whether or not there are any generators there at all, it may be that the fact that a nearby generator happens to use that rotating magnetic field to rotate its armature, has little effect on the drive motor. Certainly, Raoul didn't keep buying and adding extra generators if he was not getting any benefit from them. This arrangement has the potential of serious power gains, but it would be fairly expensive to investigate if that is indeed the case.

[John Bedini's pulsed flywheel](#) (chapter 4)

[Lawrence Tseung's pulsed flywheel](#) (chapter 4)

These are definite winners. Jim Watson built a monster size version of John's which was self-powered and had 12 kilowatts of excess power. Lawrence Tseung's prototype is only low power but it demonstrates $COP > 1$ very clearly indeed on only one set of rotor magnets. The design performance should be dramatically increased by using several sets of rotor magnets as that would raise the power levels considerably. This is a very easy home-build project requiring very little in the way of constructional skills or specialised tools.

[Lawrence Tseung's Impact Gravity Wheel](#) (chapter 4)

This is a device which has been replicated and it too demonstrates the "impossible" perpetual motion so feared by our revered "scientists". It requires minimal skills to replicate and the components are all low-cost. Definitely and interesting project to build and investigate and one which has the potential of power generation without the need for any form of input power or fuel.

[The Nudged-weights Design of Mikhail Dmitriev](#) (chapter 4)

This is a design which I have only encountered very recently and it has major potential. It does with weights, what designs like Kundel and Kelly do with magnets. Energy is extracted from the gravitational effect (if you will pardon the expression) as weights are pushed downwards. The lever arm for those weights is longer than the lever arm when they are being lifted upwards again, and that gives a continuous turning force. The increased lever arm for the falling weights is caused by a small electric motor giving them a nudge away from the rotor axle. Before the weight has time to swing back into its vertical position its rotor pivot has reached the bottom of its travel. In some of his designs, Mikhail just allows the weight to swing freely and in other designs he uses an angled ramp to control and limit the positioning. The brief presentation in chapter 4 shows tiny weights, but even for a first-time home-build replication, there is no reason why the weights should not be substantial. They can be suspended and given a ball or roller bearing suspension and the motor can have broader strips which press directly on the rectangular body of the weight. Mikhail is thinking of marketing ready-built units providing 6 kilowatts or more of electrical power, and plans and kits as well. The rotor turns slowly and powerfully and so need to be geared up to increase the speed for electrical generation.

[The Gravity Wheel Design of Abdulsalam Al-Mayhi](#) (chapter 4)

This device is very simple to build, being entirely mechanical and requiring no complicated parts. It is essentially, a wagon wheel with spokes which have sliding weights on them. If the style of construction shown in chapter 4 is used, then please be aware that a large number of roller bearings are needed. It has been suggested that spokes which have a square cross-section rather than round as shown, might be an advantage.

[Chas Campbell's Pulsed Flywheel](#) (chapter 4)

This is a good design for people who do not want to get involved in electronics as it uses standard mechanical components and an off-the-shelf motor and generator. I don't know of anyone who has replicated this design, but since nobody has any particular reason to tell me about what they have done, that does not mean anything much. The potential for excess output power is high although Chas has not made any output power measurements.

[James Hardy's Water-jet Generator](#) (chapter 2)

This device is both patented and shown on video on the web. It is very, very simple in concept and should be easy to build. Unlike the video demonstration, a proper working model is wholly enclosed and fairly quiet in operation. It is self-powered and has significant excess electrical power. Construction is very straightforward and uses readily available off-the-shelf components.

[The Robert Adams Motor/Generator](#) (chapter 2)

If built without paying any attention to the essential details, this design will operate but always be $COP < 1$ in spite of the design having an extremely high potential. If care is taken with the construction and high voltage used and the timing adjusted to its optimum settings, then an input of just 27 watts has been shown to produce 32 kilowatts of power, capable of running a household or office. Adjustments for optimum performance will take time and patience and this design is more suited to people who have some understanding of electronics.

[Pyramids](#) (chapter 9)

The usefulness of a pyramid depends to a considerable degree on how sunny the local environment is. The bulk of the energy which they concentrate flows from the sun, so sunny areas have a much higher pyramid effect than dull areas where direct sunlight rarely reaches the ground. A pyramid is not particularly difficult to construct if you have the dimensions, but size is very important with increased size having a disproportionate effect. In this area, bigger is definitely better. Covering the pyramid with gold-plated iron is the optimum, but many other much

cheaper materials can be used very effectively. Pyramids are probably better used to enhance growth and for health improvement purposes rather than for generating electrical power.

[The Tesla Coil and Grounded Plate](#) (chapter 5)

This method for extracting substantial power was disclosed by Nikola Tesla and has been demonstrated in broad outline on video by Don Smith, although he did not demonstrate equipment being powered by the electrical energy generated. A standard Tesla Coil (available commercially) directed on to a metal plate or two-plate capacitor which is connected to an effective earth wire, can supply serious amounts of electrical power. Nobody seems to be interested in using this method to generate excess energy and it is not at all obvious why that should be.

[Art Porter's Magnet Motor](#) (chapter 2)

This is a variation of the Charles Flynn motor where an electromagnet coil is used to modify the magnetic field of a permanent magnet. Art states that he gets a 2.9 times improvement in the field strength doing this and he uses it to operate a reciprocating motor. Instead of having mechanical movement, it seems as if it would be more effective to use that magnetic field alteration to generate electricity in a stationary coil as that seems likely to give a COP>1 performance and the currents used could easily be high, giving substantial excess output power. It should be perfectly possible to have a whole bank of these magnet/coil combinations in a single device.

Devices which are of Medium Difficulty

[Charles Flynn's Magnet Motor](#) (chapter 1)

This design is powered by permanent magnets which are intermittently shielded by electromagnet windings. As the construction of those windings depends on the voltage being used to drive them, the spacing between the magnets and the strength of the actual magnets used in the construction, experimentation needs to be undertaken before the final construction and assembly is undertaken. An understanding of basic electronics is needed. The power and speed of the motor are exceptional. The input power needed for the prototype described by Charles is very low with just an ordinary 9-volt dry-cell battery being able to power the motor at 20,000 rpm. If the motor is used to drive a generator (whether home-built or commercial), there does not appear to be any reason why the input power should not be provided by a voltage-stabilised power supply driven by the output, making this a self-powered system which can power other electrical equipment or a mechanical load.

[Electrical Generator Running on Water](#) (chapter 10)

As far as power output is concerned, this is a major winner as it is both self-powered and provides kilowatts of excess electrical power. As so much electrical power is generated, the design of the electrolyser used should not be critical. While the generator spark timing can be delayed so that just HHO and cold water mist can be used, the David Quirey method of bubbling the HHO through acetone, allows an unmodified generator to be used, making the project very much more simple. This project is particularly suited to people who like maintaining, adjusting and tuning vehicles.

[The Pulsed Coil of 'UFOpolitics'](#) (chapter 3)

This is a design which generates cold electricity which can safely light a bulb under water. With no moving parts, the only (minor) difficulty is constructing the electronics to drive the coil. Running off 36V, this is a very interesting design for people who want to experience the remarkable effects of cold electricity.

[Bill Muller's Motor/Generator](#) (chapter 2)

Ron Classen has replicated this design and reached COP=2.2 after very considerable expenditure of time and money. You need excellent mechanical skills to be successful with this design although the coil-shortening technique might well raise the electrical output very substantially.

[The RotoVerter](#) (chapter 2)

This design involves running a 3-phase motor from a single-phase power supply. The capacitor tuning needed to do this depends on the loading of the output unless Phil Wood's method of adding in a DC motor is used. This project mainly requires mechanical skills rather than out and out electronics. This arrangement is best suited to where an existing motor is used extensively and under those circumstances, the cost of running the original motor can be reduced substantially by the RotoVerter system and the system can be run on a solar panel used with an inverter.

[Richard Willis' Motionless Generator](#) (chapter 3)

[Silverhealtheu's adaption of the Willis Generator](#) (chapter 3)

Richard has shown his generator on the US version of The Dragon's Den television programme and he has offered his "Magnacoaster" generators for sale. I understand that the technical problems initially encountered have now been overcome and so units should be shipping at this time. The simplified 'silverhealtheu' version

should not have any problems when run at reasonable power. These devices are a starting point for experimentation and they are best suited to people who have some knowledge of electronics.

[Dan Davidson's Acoustic Generator](#) (Appendix)

[Pavel Imris' Optical Amplifier](#) (chapter 3)

These devices appear quite straightforward, but I have never heard of anyone actually attempting to replicate either of them. That being the case, they would need to be categorised as being designs which need further investigation if they are to be home-built.

[Dale Simpson's Hinged Plate and Gravity Wheel](#) (chapter 4)

[Murilo Luciano's Gravity Chain](#) (chapter 4)

These three devices have to be categorised as being untested designs and some people are of the opinion that they can't work. Until such time as they are built and tested, they have to remain as design ideas. The construction is not particularly difficult being mainly mechanical in nature, but there is no guarantee of success and it seems unlikely that the components could be easily used again in some other project.

[Dave Lawton's Hydroxy Cell](#) (chapter 10)

[Dr Scott Cramton's Hydroxy Cell](#) (chapter 10)

[Bob Boyce's Electrolyser](#) (chapter 10)

These three designs have very impressive performances, far outperforming Michael Faraday's efficiency results (which "scientists" believe are the maximum possible). For example, Bob Boyce's electrolyser design run on DC, can have efficiency results over 200% those of Faraday. Run on pulsed DC, the same electrolyser can reach 1,200% Faraday's maximum. The Lawton and Cramton cells, operating differently, also have outputs which are far in excess of Faraday's results. As more power is available from recombining the gas mix produced through burning when diluted with air and/or non-combustible gasses, or through use in an internal combustion engine, these devices represent considerable possibilities. However, the amount of work involved is not trivial and the use of the gas mix produced calls for ingenuity, so these are devices which have a high potential but they are not an instant-fix for anything.

[The Rosemary Ainslie Heater](#) (chapter 5)

This is a most interesting design which has COP=17. However, at the present time, power levels are so low that while it may be an interesting project and the principle is more than interesting, the output of this device is too low to provide any form of useful heating.

[Robert Patterson's Ram Wing](#) (chapter 10)

This is a simple physical device capable of improving the air flow around a moving vehicle to such an extent that it produces better mpg figures for the vehicle. Constructing one and mounting it on a vehicle is not a difficult task and the gains can be significant.

[Co-Axial Cable Electrets](#) (chapter 9)

This is a system which nobody seems willing to try. It involves baking a reel of co-axial (TV aerial) cable in an oven and allowing it to cool down very slowly. It is capable of supplying 10 mA at 10,000 volts which is a continuous power of 100 watts (better than most solar panels). The output energy from this passive device is drawn in from the surrounding environment. The high voltage of the output appears to put people off this device.

[The Colman / Seddon-Gillespie 70-year Battery](#) (chapter 3)

This is a device which has major potential and yet one which nobody seems interested in attempting to replicate. It is a small, compact, simple device which can provide one kilowatt of excess power for an estimated seventy years. Several of these in a single small housing could supply the electrical needs of a whole household. The materials used are not hazardous in any way and apart from some basic electronic circuitry and experimentation, there does not appear to be any problem with attempting to replicate it.

[Robert Krupa's "Firestorm" Spark Plug](#) (chapter 10)

This plug design is quite capable of giving improved fuel burn inside an internal combustion engine that the mpg performance can be increased very substantially and harmful emission drastically reduced. While Robert has a patent on his designs, he has not been able to find any manufacturer willing to make and sell Firestorm spark plugs. Prototypes have been made by getting a jeweller to modify a new set of standard spark plugs. This is expensive, but it is definitely something which is possible to do.

[Jesse McQueen's Self-powered System](#) (chapter 13)

On the surface, the patented proposal by Jesse appears to be impossible. However, as our understanding of how the various free-energy devices draw in environmental energy increases, some of the more impossible looking devices suddenly look as if they might actually be based on principles and methods which have been proven to work. Essentially, a battery powers a motor which spins a generator which keeps the battery charged and powers other devices. If both the motor and the generator are COP<1, then the system won't work. But, gearing is used

between the motor and the generator, and Chas Campbell has shown that with a flywheel in that linkage, additional power **is** actually available. It may be that Jesse does not mention the fact that his gearing linkage is heavy. It is interesting to note that the gearing that he specifies, has the correct ratio that Jacob Byzehr specifies in his patent for an energy gain through such linkage. It seems likely that Jesse has not disclosed all of the details in his patent. While constructing a test bed for this system should be easy if you have the components to hand, I suggest that you consider it to be an experimental investigation of his claims and don't expect immediate, spectacular results.

[Robert Tracy's Permanent Magnet Motor](#) (chapter 1)

This style of motor with magnetic shields being physically moved between pairs of magnets is probably one of the more difficult magnet motors to get operational. The main problem is getting an effective magnetic shield material. The expensive "mu-metal" material is supposed to be effective if it is fairly thick, but I am by no means sure that this is the case in actual practice. Screening powerful magnets with a passive material is not an easy thing to do and there are very few materials which seem able to do it. It might be possible to use a thin neodymium magnet as the 'shield' if it were orientated so that it was in repulsion mode for both the stator and rotor magnets as they approach each other. Because of the screening material problem, I could see the building of a Tracy prototype to be a lengthy experimental process in spite of the fact that the theory is perfectly sound.

Devices which require higher skill levels

[Muammer Yildiz's Permanent Magnet Motor](#) (chapter 1)

This motor has been demonstrated in a Dutch technical college and taken apart after the initial running was completed, showing that it's operation was wholly genuine. However, some of the magnets used are of a tapered type which are probably not readily available unless ordered as a specially constructed batch which is generally an expensive way to buy magnets. Magnetic fields and their interactions and distortions are not the easiest things to understand or observe in a practical situation, and that makes the construction of permanent magnet only motors a difficult job. Howard Johnson and Mike Brady managed to make successful prototypes but then found it almost impossible to make others to that same design. So, if you decide to replicate Muammer's motor, please understand that it is not likely to be an easy thing to do.

[Michael Ognyanov's Self-Powered Power Pack](#) (Appendix)

This is a low power device intended to operate the lights on road traffic cones without the need for a battery. There should be no particular problem in building it if it were not for the need to cast a semiconductor block from a mixture of materials such as silicon, germanium, neodymium, gallium, etc. It seems likely that the average home constructor of devices is not geared up for melting and casting such materials, and so that puts it into the 'higher skills' bracket.

[Don Smith's High-frequency, High-voltage Devices](#) (chapter 3)

These devices appeal to a high percentage of interested people and yet they seem to be some of the most difficult to replicate. Admittedly, Don does say that he has not revealed all of the details on any one of his designs, but independent people have confirmed that doubling the voltage quadruples the output power and that additional electrical outputs can be produced from the fluctuating magnetic field without requiring any additional input power. Considering the limited success encountered by several people who have tried to construct replications, these devices have to be rated as some of the most difficult to get operational. Having said that, success has been achieved by putting two Tesla Coils back-to-back, connecting their secondary coils with a wire and taking the output from the larger diameter "L1" coil of the second Tesla Coil.

[Jerzy Zbikowski's Chain Drive](#) (chapter 4)

This device looks impossible, and yet it is reported to have been laboratory tested at COP=1.47 which is quite remarkable. As it is a mechanical chain drive, it requires good mechanical skills to construct the chain links and the two sprocket wheels. The mechanical operation needs to be high-quality, so it is unlikely that beginners to mechanical construction would have immediate success.

[The Magnetic Pendulum](#) (chapter 4)

While I don't know the name of the builder, this pendulum is reported to have been swinging continuously for more than two years now and while it does not appear to generate any useful power output, it is certainly an amusing project, especially should you want to show it to those people who say that 'perpetual motion' is impossible. It might well be possible to adapt it so that the magnetic push provided by dropping permanent magnets downwards near the end of the swing were provided instead by a coil which extracts power and then, when the current is cut off, generates the necessary push from the magnetic field generated by the back EMF. While the output power would be low, it would be very nice to demonstrate power generation with no input power being provided – just pure energy extraction from gravity and magnets (both of which are powered by the zero-point energy field).

[The Tesla Switch](#) (chapter 5)

This is one of the most difficult devices to get operational, in spite of the fact that it appeals to a large number of people. There are three possible modes of operation. If the diodes are turned the wrong way round so that they can feed current from each battery, then the operation will definitely be COP<1 but it will be a good deal better than operating without the switch circuit in place.

The second way has only been achieved by John Bedini as far as I am aware. This is where the circuitry is the same but the circuit components and connecting wires are adjusted very carefully to produce circuit resonance. When that happens, the circuit becomes self-powering although there is little or no extra power for other devices.

The third way was developed and tested over three years by staff of the Electrodyne Corporation in America. In this version, the diodes are reversed and they only feed sharp voltage spikes back to the batteries, through the diodes which supposedly don't allow current to flow in that direction. This is a very different form of operation where the operating power flows into the circuit from the local environment. The batteries need to be 'conditioned' through long periods of being operated this way as the 'cold electricity' used in the circuit is the opposite of the 'hot electricity' which the batteries have been using up to now. This long conditioning period is generally enough to make the average builder give up and believe that the circuit just doesn't work. Dave Lawton was faced with exactly the same type of problem when he attempted to replicate Stan Meyer's "Water Fuel Cell". It appeared 'dead' and produced nothing during a whole month of testing, and then it suddenly burst into life, producing large amounts of HHO gas mix for almost no electrical input. Without his exceptional patience, Dave would never have succeeded. I believe that the same applies to the Tesla Switch when wired correctly with the diodes blocking current flow from the batteries – it is likely to take long-term and patient testing before the system swings into life.

One experimenter who did not believe the diodes could possibly work that way round, tested the arrangement and discovered that in spite of the theory, in practice, the reverse-biased diodes actually pass very sharp voltage spikes to the batteries, so the effect may well be like a slick version of John Bedini's battery pulsing circuits.

[Hermann Plauson's High-Power Aerial Systems](#) (chapter 7)

Hermann Plauson's patent which is in the Appendix, is so detailed and authoritative that it gives every indication that he is highly experienced in the actual design, construction and installation of serious aerial installations. He casually refers to "small" installations as being those of 100 kilowatt or lower capacity, so we are not talking about milliwatts here, although I understand that Hermann extracted somewhat under one kilowatt per aerial and used many aeriels in any one installation. The difficulty with these types of system is that the input is very high voltage 'electrostatic' electricity, usually thought of as being useless for power generation. It is therefore, important to consider carefully the mechanisms which Hermann has in his patent for converting that power to ordinary electricity at normal voltage and current levels. We need to remember that Paul Baumann's "Thestatika" devices operate off this type of input power and yet put out kilowatts of mains electricity, so we know that it is perfectly possible. We do not have step-by-step building instructions for these types of system, and so they have to be rated as requiring more than the lowest skill levels. Also, many people are not located where they can erect a tall aerial, but remember that the Thestatika uses a Wimshurst style electrostatic generator rather than an aerial, so experimenters can work with a generator input. A.D. Moore's "Dirod" electrostatic generator seems like the most suitable home-build generator. It is described in detail in his book "Electrostatics – Exploring, Controlling and Using Static Electricity" Second Edition ISBN 1-885540-04-3 which is the only source for construction information on his generator.

[Frank Prentice's Ground Aerial System](#) (chapter 5)

Frank's design uses a one mile long wire supported just a few inches above the ground. He inputs a modulation signal of 500 watts and extracts 3 kilowatts of power. The information in his patent is not exactly overwhelming in its details, but the major obstacle is that very few people can install any such wire. It is not known if the wire could be run backwards and forwards over a small area, but if that were possible, then it would form a barrier against the normal use of that area. Frank didn't have that problem as he worked on railway tracks. The limited amount of information adds to the skill level needed to be successful with his design.

[Alfred Hubbard's Electrical Generator](#) (chapter 5)

This has a very high potential as it can put out substantial electrical power in spite of its simple construction. As it is based on just one section of the magnetisation graph where a small additional current produces a major rise in the magnetisation of the iron core, it will require careful adjustment and attention paid to the magnetic saturation levels of the materials used. It is very interesting that Joseph Cater's analysis of the device has spacings which match the recently discovered optimum tube spacings for the Joe Cell. I am not aware of anyone who has managed to replicate Alfred's device.

[Joseph Cater's Water-filled Generator](#) (chapter 5)

This looks like a really good design but it has the problem that it needs a transducer or klaxon running at 600 kHz and there does not appear to be any such transducer readily available on the market. The highest frequency I

have located was just 300 kHz which is clearly not suitable, so this design appears to be restricted to people who have skills which can design and construct a klaxon which can operate at 600 kHz.

[Joseph Cater's 'Orgone' Box](#) (chapter 9)

[The 'Joe Cell'](#) (chapter 9)

[The 'Nitro' Cell](#) (chapter 13)

In theory, each of these is capable of running a car engine without the need for any form of combustible fuel. I am aware of people who have succeeded in doing this with the Joe Cell and the Nitro Cell, but they both live in much sunnier locations than I do. These devices are some of the most difficult to get operational and it could well take a week for the car to absorb the cell influence before it can run without fuel. It has to be said that the technology involved in the operation of these devices has not been fully documented at this time and so is not fully understood and so experimenting with them is effectively a research project.

[Fuel-less Engines](#) (chapter 8)

These engines are perfectly viable but few people have the knowledge, skills, tools, workspace, inclination and time to go building or modifying an engine. These are Engineering tasks and not generally suited to 'back-yard' projects.

[The Searle-Effect Generator \("SEG"\)](#) (chapter 11)

According to John Searle, constructing just one of the many magnets needed for his generator requires more than a day of work and a million pounds in finance. This is enough to put most people off even considering his design. However, John certainly didn't spend anything like that amount of money when he built his first successful prototype, so we can probably ignore the quoted costs. Investigation would need to take place through the enthusiasts on John's forum and web site, but unless something has changed recently, it will probably take considerable research and subsequent thought in order to come up with a viable design for the construction of a useful generator or a flying disc.

[Michael Eskeli's 'No-Work' Turbine](#) (chapter 11)

Michael is clearly a gifted and very competent man who has many patents. In common with most gifted inventors, he does not excel in explaining and documenting his inventions and so a certain amount of background Mechanical Engineering knowledge would be of major help in understanding how to home-build one of his designs. The No-Work heating turbine in chapter 11 is a heater which only needs the friction of the bearings to be overcome by the motor spinning the turbine as the actual heating effect is 'free'. This is, of course, spectacular. If you happen to be a gifted individual and replicate Michael's turbine, then I would be most grateful if you would fill me in on suitable construction methods so that I could expand the description into a more detailed version which would encourage people to build one for themselves.

[William Hyde's 10 kW Electrostatic Generator](#) (chapter 11)

This involves the construction of a rotary generator with metal bodywork and so metalworking skills are needed (or somebody else with those skills needs to help out or be paid to do the work). The completed electrostatic generator has been patented and it is claimed to have an output of ten kilowatts of ordinary electricity, which makes it of serious interest to anyone needing to power a household. It is reputed to be COP=10 which means that the input power will be substantial for a large electrical output.

[Michael Faraday's Homopolar Generator](#) (chapter 13)

This design appeals to most people as it looks so simple. However, the problem is that most versions produce a very low voltage at very high current – potentially a thousand amps or more. Trying to come up with brushes which can carry high current for long periods of time without appreciable wear has proven to be a major problem. The Borderlands Science people discovered how to get an AC output from the device which allows the voltage to be stepped up and the necessary current reduced substantially. To date, I am not aware of anyone managing to produce a homopolar generator with a practical power input and output, but it is definitely a device which is wide open to experimentation.

[The Romag and Mini-Romag Generators](#) (chapter 13)

These designs call for construction with a range of different materials, and generally speaking, the materials used in any prototype are normally of major importance. Although these designs have been available for many years now, the only prototype which I have heard of is the 25 watt version built by J.L. Naudin, although there is probably not particular reason why the Romag could not be scaled up to produce a much larger output.

[Nikola Tesla's Generators](#) (chapter 11)

Neglecting the version which uses radium as that is probably difficult to obtain at the present time, the spark gap version is said to produce very substantial amounts of electricity while only using very simple components. I have never heard of anyone attempting to build one of these devices but in spite of the fact that we have limited information on the device, it seems like a very powerful unit which could well be extremely useful.

[The Jines Permanent Magnet Motor](#) (chapter 1)

This design includes magnetic shields and finding a suitable material for them might be a considerable problem. This design has to be considered to be fairly complicated due to the amount of mechanical work needed to construct the various mechanisms required for the motor.

[The Annis and Eberly Generator](#) (chapter 3)

This is a very clever solid-state generator. However, from the point of view of the home-constructor, producing their solid-state reluctance-switching material and it's controller would appear to be a major obstacle. Given that material and it's controller, many of the other devices would be exceptionally easy to build successfully.

[The "Carousel" Permanent Magnet Motor](#) (chapter 1)

This is a compact and very effective looking device but the very compact nature of it's construction probably makes it somewhat tricky to replicate. Anyone with good metalworking skills should be able to do it ok.

Devices which are unlikely to be practical

[The Ecklin-Brown Generator](#) (chapter 1)

People have had difficulty in making replications of this to work well. The biggest problem area is coming up with suitable magnetic screening material. It might be possible to adapt the design to use some of the very thin neodymium magnets instead of material which just screens the existing magnetic field. The Clemente Figuera design of chapter 3 is a better option.

[Howard Johnson's Permanent Magnet Motor](#) (chapter 1)

It appears that Howard has not been able to build replications of his original working prototype and while the theory is perfectly valid, that failure has to put a question mark against almost all permanent magnet motors of that type, especially since Mike Brady experienced exactly the same thing and Australian developers with a successful "Lutec" magnet motor found that they could not replicate it unless they used parts from their original prototype. The V-magnet system of the Hohl Motor in chapter 1 is an exception to this problem.

[Mike Brady's "Perendev" Permanent Magnet Motor](#) (chapter 1)

This design is in exactly the same position as Howard Johnson's Permanent Magnet Motor. It seems that Mike has experienced considerable difficulty in constructing working copies of his prototype. If you want to try to build one, by all means feel free.

[Floyd Sweet's "VTA" Magnetic Generator](#) (chapter 3)

Shown on video, producing more than 500 watts of mains output power for 1.2 milliwatts of input power, this is clearly a device of major importance. Unfortunately, we do not have Floyd's method of producing isolated and easily moved magnetic poles in a block of magnetic material and that is a major obstacle for the would-be replicator. I am not aware of anyone who has successfully replicated Floyd's device.

[Oleg Gritsevitch's Toroidal Generator](#) (chapter 5)

This incredibly successful and powerful device which produced 1.5 megawatts continuously for two years, took major equipment to get it started. It is not known if it can be successfully constructed in a smaller size and the coating between the water in the toroid and the toroid casing may be difficult to achieve.

[Tariel Kapanadze's Electrical Generator](#) (chapter 3)

Unfortunately, Tariel has repeatedly refused to reveal how his designs operate. He has also been involved in several very questionable business deals where the other party felt cheated. It is most unlikely that he will ever reveal the details. Replicating it is not really a beginner's project and an overunity.com forum has been trying to replicate it for a long time now.

[Hans Coler's Devices](#) (chapter 9)

The passive design of Hans Coler can certainly be made to operate if you can persuade it to begin oscillating. The output is quite small but interestingly, it does demonstrate that we are indeed surrounded by energy which can be tapped for practical purposes. This device needs patience in order to get it going.

[The Meyer-Mace Isotopic Generator](#) (chapter 3)

I have never heard of this design being replicated. It calls for a 21 MHz generator which is quite a high frequency for the home constructor. The design itself is certainly simple but getting it to work if it doesn't function initially is not likely to be easy. The Nuclear Magnetic Resonance involved is explained by William McFreey in chapter 3.

[Ed Gray Power Tube](#) (chapter 5)

Ed Gray's power tube is unlikely to be $COP > 1$. The genius behind his achievements was Marvin Cole whose ambition was to be a chef. Marvin built a motor which was certified as $COP = 237$ by Cal-Tech's independent testing, but when he disappeared from the scene, Ed was left at a bit of a loss. Ed only produced patent applications in order to reassure his investors and he never wanted to disclose anything of worth. Mark McKay's detailed information in the Appendix provides extensive background and Mark has now written a book on the subject.

[Roy Meyer's Aerial System](#) (chapter 7)

I know of only one person who tried to replicate this design. The first time he tried it, it worked ok although it was not aimed in the 'right' direction, but he was never able to get it to work again. So it appears that while the design may well work, it is not easy to replicate and get functioning.

[Karl Schappeller's Device](#) (chapter 11)

To be perfectly honest, I have never managed to understand the work of either Karl Schappeller or that of Viktor Schauburger. Not properly understanding the design makes me believe that newcomers to free-energy construction work would have difficulty with this device. That may well be an unfair assessment and if you are able to build and use this design, then please explain it to me so that I can document it properly.

[The "HydroStar" and "HydroGen" devices](#) (chapter 13)

These designs have been around for a long time and to date I have never heard of anyone who has managed to build one and got it to work. In theory, they are supposed to allow a car to run with water as the fuel. On the surface, I can see no way that that could happen unless it operates as a version of the Joe Cell, which it very well may do. If that is the case, then great patience will be needed before the vehicle will operate. I would not recommend anyone to build either of these designs.

[Francois Cornish's Aluminium-feed System](#) (chapter 13)

This system is not economical in the broad sense in that it takes more energy to produce or reform the aluminium than is given out when it is converted to oxide in the process which produces hydrogen for combustion. It can be economical for the user in that the processed aluminium is less expensive than oil products. However, the oxide residue generated by the process limits the effective applications for the process as a whole. It is not a good constructional project.

[The Motionless Electric Generator \("MEG"\)](#) (chapter 13)

This is a device which most people find very difficult if not impossible to get to $COP > 1$ operation. If the frame is made of Metglas nanocrystalline material, then it might be possible. However, the design has been around for a decade and it has not (yet) made it to commercial production, so I would suggest that this is a device which is not a good choice for a constructional project.

Devices which are not really possible

[The ShenHe Wang Permanent Magnet Motor](#) (chapter 1)

While there is a patent for this design, there is not enough information for there to be any reasonable degree of success if you were to try to replicate it. For that reason, it probably should not be considered as being a viable construction project at this time. It may well become available commercially at a later date.

[Thomas Henry Moray's Aerial System](#) (chapter 7)

While this device is, without question, a most impressive device which was demonstrated in public on many occasions, Thomas was intimidated and so never released full constructional details of how his device worked. That lack of specific information prevents this from being a realistic constructional project.

[Steven Mark's Toroidal Power Unit \("TPU"\)](#) (chapter 5)

While this unit has been demonstrated on video, showing impressive operation, I understand that it overheats after 22 minutes of operation. That is not a major problem and could be overcome, but the lack of specific constructional or design information makes this a research project rather than a normal constructional project.

[Paul Baumann's "Thestatika" Generator](#) (chapter 13)

The late Paul Baumann designed and built several self-powered generators which were demonstrated on many occasions. These are still in the possession of a Swiss religious commune who refuse to release the details as they think that "the world is not ready for this information". The lack of the vital design information makes replicating the device a non-starter which is a great pity since it has a substantial mains power output which could ease suffering around the world.

[Muammer Yildiz's "Ocean Star" Generator](#) (chapter 13)

While the demonstration of this device looks quite like a hoax, Muammer's credibility jumped massively with the production of his current permanent-magnet-only motor which has been demonstrated publicly. The "Ocean Star" device was supposed to be able to power a house, but the patent information is not nearly clear enough to deduce how to build the device. Perhaps somebody could ask Muammer to explain it in more detail and disclose the key design details in order to allow home-built replications.

Topic: Electrolysis

Question:

I was reading the D9.pdf file you put together on Bob Boyce's electrolyser and PWM3G circuit. The close up picture of the PWM3G circuit shows only 5 LED lights but below under the **Testing the Completed Board** section it talks about 8 LED lights. also on the animated picture (the one with all the components on the board) there are 8 led lights. did bob build another type of board with fewer LED's on it? If so could you explain how to test the different board? Also I was considering buying the board from the Hydrogen Garage website, would you recommend this?

Answer:

The D9 document was created long before the 3G version of the board was produced. The version shown in the document is only there to give an impression of what the board was like at the time. Bob has always been reluctant for any specific details of his circuits to be published which is why the circuit schematic is not shown in the document.

The supplier of your board will tell you how to tune it. I would not expect it to be a different method. Essentially, you start with the frequency variable resistors in their central position and the Mark/Space resistors set to about 10% On time. Then you tune the top frequency of 42.8 kHz to give the best gas output. You then adjust the middle frequency to give the best gas output. Finally, you adjust the lowest frequency channel to give the best gas output. The Hydrogen Garage in the US or Courtierstown Marine in the UK can advise you.

The Hydrogen Garage is run by a very honest and reliable electrolysis enthusiast with many years of practical experience behind him, and there is no reason why you should not buy from there if you want to.

Question:

OK, so if I want to build one of those boosters and I have 14.8 volts in my car how am I going to power 18 plates 5" x 4". That's the only thing that's confusing because there would not be enough voltage

Answer:

I'm not sure where the idea of 18 plates came from. It is likely that your electrics give 13.8 volts rather than 14.8, although that is not critical in any way.

You are aimed at seven cells in a chain so that each cell gets about 2 volts across it. If you put partitions in your box, then with your proposed current you would use just two 5" x 4" plates per cell - a total of 14 plates. If you wanted to provide more plate area, then you would use three plates per cell, making 21 plates.

However, if all your journeys are short and the cell will never get up to its full temperature due to the short time it operates, then you could go for just six cells and with three plates per cell and that would make 18 plates.

If you use separate plates, then you have the difficulty of making good-quality electrical connections between six pairs of plates, and that can be quite difficult to do. I would suggest that you consider the bending method shown at the start of Chapter 10 as that overcomes the need for making any electrical connections inside the cells.

The best plate performance is with two to four square inches per amp of current. As only bending is involved, it would pay off to have a generous plate area, especially if you are using mesh. Mind you, the mesh surface area is not much reduced by the holes as the surface around each hole as it passes through the thickness of the plate is also active. The hole edges are also very helpful in getting the bubbles to break away when the cell is new. Later on, when the cell is conditioned, the bubbles will not stick to the plates at all.

Question:

Is it possible to generate electricity using hydroxy gas?

Answer:

Yes, it is perfectly possible to generate electricity using hydroxy gas:

1. Take a standard electrical generator such as a Honda 6.6 kVA V twin or a Vanguard V twin.
2. Adapt it by filling in the timing key slot and cutting another which lets you set the spark timing to two degrees after TDC.
3. Build any electrolyser capable of producing 5 lpm of hydroxy gas.
4. Feed the generator air, hydroxy and cold water mist from a Venturi tube, pond fogger or miniature carburettor.
5. The generator can run well on that and produce kilowatts of excess electricity over and above the amount needed to power the electrolyser.

This has already been done on at least nine different generators and run 24 x 7 for two and a half years now. However, please be aware that generator engines wear out eventually and will need a rebuild or replacement, so the electricity produced is not "free".

Q: What mmw (efficiency) rating of hydroxy generation is need to achieve this? Also, is it necessary to be using some type of resonance system or will brute force/catalytic electrolysis work?

A: You can use any type of electrolyser you like. Unlike the alternator in a vehicle, a generator is designed to put out a major amount of electrical power on a continuous basis. So, if you take half a kilowatt or more generating the hydroxy, who cares? If the generator is called a 5.5 kW by the manufacturer and you wish to run it at 4.5 kW assuming that the seller is being generous with his rating in order to compete with other brands, then if you use 0.5 kilowatts (12V at 40 amps) for electrolysis you are definitely in business. The two makes of generator quoted, have proven very reliable in long-term use. The addition of very tiny cold water droplets is a key factor in making this work.

Question:

Do you know if the V-twin Vanguard and Honda generator you have mentioned, do not have the waste spark? I would like to buy one, but need to make sure before doing so.

Answer:

The people who have done these conversions say that retarding the spark to 2 degrees after Top Dead Centre was sufficient. Never having worked on internal combustion engines, I can't personally confirm it myself from my own experience.

If you decide to do it and are successful (as I would expect), then I would be happy to produce a document for you which would go out under your name. If you decide to do that, then please take photographs before, during and after your filling in of the timing key slot and the cutting of the new one as that is one item which would benefit from having detailed pictures. Supplier details for the cold water mist device which you pick, be it pond fogger, Venturi tube or miniature carburettor, would be helpful for others following after you.

Question:

Do you have any values for Peter Lowrie's coils, the ones mentioned in the doc are "from a commercial installation with copper sheet wrapped around them" as it is my intention to use a Marine alternator.

Answer:

There are two different techniques for producing hydroxy gas:

1. Pulsed DC signal which can reach 1,200% Faraday.
2. Brute force DC which is usually less than Faraday although with great care, it can reach 212% Faraday.

Peter Lowrie used a marine alternator solely because he wanted three separate 2-volt supplies at 900 amps each. It was because of his very high current that he used an industrial 3-phase power supply choke. Unless you are aimed at currents that high, then you definitely don't need chokes of that massive current capability.

If you are determined to use a similar item, then you need to look at the spares options for professional, commercial equipment. Peter only used a marine alternator for its very high current producing capability and he told me that a second-hand truck alternator would do just as well.

Question:

You said...

"When that gas is added to gasoline droplets in a gasoline engine, it acts on those fuel droplets during the compression stroke, breaking those long chains of hydrogen and carbon atoms into shorter, more active fragments of chains. This produces more active and better combustion of the fuel when it is ignited by the spark, and that extracts more energy from the gasoline, energy which would have been wasted in the catalytic converter and in producing unwanted excess heat in the engine".

This is the first time I have heard that the Hydroxy is doing something BEFORE it is ignited. I thought the Hydroxy ignition was what was breaking down the gasoline into short molecules? Can you explain this more?

Also, can you email me here or privately what you feel are the best Free Energy Devices these days. I think many may be interested in Free Energy Devices to drive their electrolyzers. I'm interested in the devices themselves. Also, is anything near to coming to market?

Answer:

On 14th January, Bob Boyce's post to his Hydroxy forum included the statement: "When either hydroxy gas, or HHO, is compressed in an engine cylinder, it is after it has been diluted with intake air, as well as fuel in non-diesel engines. Not only does the dilution in air raise the auto-ignition pressure, but in non-diesel engines the orthohydrogen has already bound to the long hydrocarbon fuel chains and broken them prior to compression. As this bonding occurs, orthohydrogen decays to parahydrogen. It is the energy from this decay which breaks the hydrocarbon chains into simpler hydrocarbons. These simpler hydrocarbons combust much more efficiently and completely. With diesels, the process is slightly altered, as there is less time for bonding to occur, so improvement occurs much better at lower RPM than at higher RPM".

Gasoline molecules vary from chains of seven carbon atoms surrounded by sixteen hydrogen atoms, to chains of nine carbon surrounded by twenty hydrogen atoms. These chains need to be broken down in order for those hydrogen atoms to combine with oxygen atoms from the air in the cylinder, to produce the heat and expansion which powers the engine. That is why the spark is generally about eight degrees before Top Dead Centre, giving time for this to happen. The more broken up those chains are before the spark, the better.

With regards to free-energy devices, I get asked on a regular basis, what device is best for somebody to try building. The question always comes without the relevant details needed to even make a rough guess at a realistic answer. There is generally no information on country, skills, tools, finance, workspace, time available, main objective, local materials available, environmental space, etc. etc.

Obviously, if someone has converted a pick-up to electric operation and could put a water-fuel generator in the back, the kilowatts of excess electrical power would extend the battery range substantially and would recharge the batteries during a meal break or while away from the vehicle.

This chapter is an attempt to answer your question as to what devices you might choose to attempt to replicate. There is massive opposition to any free-energy device being brought to market. Shenhe Wang intended his permanent magnet motor/generator design to be given freely to all countries in the world. I always felt that he had to be completely unaware of how governments who get billions per year in oil taxes and utility company taxes, would view such a venture, not to mention the oil companies who would see their massive revenue stream being threatened by the introduction of a small device which can output kilowatts of electrical power without using any form of fuel. At this time, it appears that Shenhe's generator is being restricted to China, which hardly comes as a shock.

Chas Campbell in Australia has a viable, commercial machine which also produces significant power without the need for any fuel. He can't find anyone interested in manufacturing it and his local power company just doesn't want to know. However, there are several devices which are nearing being brought to market at this time, and I would expect to see them in use early in 2013.

Question:

I have bought a 7-cell, series-connected electrolyser but the terminals are not marked for Plus and Minus connections. Does it matter which way round it is connected?

Answer:

Any series-connected electrolyser will operate well when connected either way around. However, there is an effect if the unit has already been run. If you are aiming for the top level of efficiency of DC electrolysis, having prepared, cleansed and conditioned the plates with Bob Boyce's methods, then the plates will have been conditioned with the current flowing in one direction. If the direction of current flow is reversed on Meyer type cells the conditioning reverses, the performance drops off and then the conditioning rebuilds, bringing the performance back up again. I am reasonably sure that the same thing happens in a Boyce conditioned electrolyser, so if at all possible, try to identify which way round the unit was originally connected and keep to that direction of current flow.

Question:

In Bob Boyce's electrical diagram, it shows three heavy-duty chokes: one from the rectifier bridge positive, one on the negative and one from the positive line to the circuit board. My question is: "what is the value or specification for these chokes and where can you find them?"

Answer:

There is a document called "D9.pdf" which provides the details of Bob Boyce's resonant electrolyser design. On page 30 of that document, immediately under the circuit diagram it tells you the choke core, the supplier of that core, the wire used to wind the choke and the number of turns to be wound on the core.

Question:

What size hose would be required to run a V-8 on all hydroxy? Does anyone have a flow chart for gas, or know where to find/get one?

Answer:

It is not possible to answer your question directly as we don't know what rate of gas flow you think would be needed or how long the pipe has to be. There is a table of pipe sizes for various gas flow rates on the web site: http://www.engineeringtoolbox.com/natural-gas-pipe-sizing-d_826.html and as 1 cubic foot per hour is about 0.15 litres per minute, if you were feeding the engine 150 lpm, then the table entry would be 1000 cu. ft./hr. and you would be looking at the nominal pipe size of 1.25 inch inner diameter. My guess would be a 1.5 inch pipe as the less restriction to gas flow the better. If you want to get a feel for the capacity of any particular diameter of pipe, then try blowing through it. The results are surprising and a small pipe around a quarter of an inch in diameter (6 mm) is incredibly difficult to blow through in spite of looking like an easy gas-flow path.

The amount of gas needed for your engine is reduced massively if you add cold water mist to the intake air. Nobody can answer the question for you because engines vary so much. Even supposedly identical engines have very different gas requirements, so you really need to experiment with your engine to discover what it actually needs. There is some cold water mist information in Chapter 10.

Q: Thank you for that chart, it's just what I was looking for. Now that I know what size of pipe can carry any particular gas-flow rate, I guess the real question is "how many lpm would it take to run a 318 cubic inch Dodge motor?" I read somewhere that it takes 80 litres per minute per 100 cubic inches of engine capacity. I may have got that backwards. Any thoughts?

A: Unfortunately, there isn't any fixed answer to your question and you definitely can't use a rule of thumb to get a reliable answer. Using cold water fog from a pond fogger reduces the amount of hydroxy gas needed by a large percentage, so try reading Chapter 10 which explains this. You need to understand the operating principles if you are to be successful. Also, you have a much easier task if you start with an engine which is much smaller in size, so I suggest that you begin with an electric generator of about 6 kilowatts as described in Chapter 10 before trying to run a very large engine of 318 cubic inch capacity (5.21 litres), which is about twenty times more difficult.

Question:

I am trying to make different devices in order to improve gas mileage on my car. However, I have some difficulties in understanding the automotive circuits. Could you, please, help me?...

I found in Tad Johnson's experience this: "What I found frustrating is that the cell temperature would change and the system would stop making gas. In order to keep the system making gas you constantly have to keep the cell in resonance, and thus you really need the system to be controlled by a processor, that constantly checks frequency on both legs and then adjust inductance to keep the cell in resonance. This is why Stanley moved to the other patents where the spark plug type of electrolysis chamber was used instead of a large cell."

In this case you gave me a clue in this paragraph: "A John Bedini pulser circuit can be used very effectively with a cell of this type and it adjust automatically to the resonant frequency as the cell is part of the frequency-determining circuit."

First, I didn't find in your book a Bedini pulser circuit so please give me direction where I can find it.

Second, in Stan Meyer's large cell, I understand, we have two kinds of resonance. One resonance is in an LC circuit where the "C" is the cell itself and the coil is the "L". This is electronic resonance. Another resonance is mechanical resonance where the tube pairs vibrate at the same frequency as the electronic circuit (or a harmonic of that frequency). In this case if I make a device to check the current of the cell, this device can adjust the frequency to be identical with the frequency of the tubes, because the current is in direct relation with resonance. If I am wrong, please let me know.

In your book there is a quotation which says: "I plan to market a pre-programmed chip capable of making any hydroxy system work. While I plan to have a profitable venture with the professional pre-programmed architecture, I also believe in the open source do-it-yourself community, which is where I got started. The chips I plan to sell will be a 'plug and play' device. You send me the info on the type of vehicle you are modifying, and the efficiency data of your cell, and I'll be able to send you a chip that will make your ECU work with those conditions. The Do-it-yourself version would be quite time consuming but, would work for less than one quarter of the price." I may be interested in buying the chip if you let me know the price before I order it.

Answer:

Tad Johnson used 1,200 volts and was able to get 3 lpm of hydroxy gas at just 1 milliamp of current (1.2 watts) but he found that he could not scale it up for greater gas output.

Chapter 10 has a circuit which finds and holds a cell on its resonant frequency and that circuit will be available ready-made from Courtierstown Marine in the near future. The Stan Meyer "Water Fuel Cell" has been replicated by Dave Lawton of Wales and the full construction details are in Chapter 10. Further advances have been made by Dr Scott Cramton who is getting 6 lpm on just 12 watts of input energy (plus the waveform from the generator which he is boosting - probably 36 watts overall - 12 volts at 3 amps) and who can reduce the diesel requirement of any diesel engine or generator by 60%. Chapter 10 also shows how to run an electrical generator on water alone.

The ECU piggyback chip details are found in the <http://www.free-energy-info.tuks.nl/D17.pdf> document and it is Les Pearson of the USA (lespearson@hotmail.com) and not myself who is dealing with piggyback chips. I am located in the UK and European vehicles have a completely different computer control system to the ECUs of vehicles in the USA.

Question:

My project is to deliver HHO to a Mazda turbo rotary with 13 lbs boost. I'm not comfortable about injecting HHO into the low-pressure side of the turbo. Even though it's mixed with incoming air, the turbo radial scroll is a wicked device with lots of sharp blades and turbulent flow. The discharge air at full power can reach over 300 degrees Fahrenheit and easily exceed the 13 lbs boost to compensate for losses. This pressurised air charge is sent to a double-pass intercooler before going on to the manifolds. A violent, hot, and long path. If the HHO survives the journey it has definitely reverted to diatomic.

I need to know what to expect if the HHO can leave the bubbler/dryer and move directly to a diaphragm compressor (premixed and diluted with air, if necessary) for direct port injection at 20 psi. What data are available to show auto-ignition at 15 psi? What temperatures, concentrations, method of compression, etc. If I can't up the delivery pressure for direct port injection, I might consider stopping development of my prototype. Please, there must be a safe way to do this???

Answer:

This subject has come up several times on the different forums and the experienced people recommend putting the hydroxy in on the low-pressure side of a turbo-charger. The hydroxy gets heavily diluted by being mixed with the incoming air and so its characteristics change before it reaches the potential trouble spots which you mention. I am not an automotive expert and so can't make any useful comments from my own experience.

One or two people have tried putting it in on the high-pressure side and have found it ok, but it is distinctly possible that their hydroxy gas was low-grade and already laced with hot water vapour, lowering its energy level and potential hazard, so my money is definitely on the low-pressure side.

The self-ignition at 12 to 15 psi information comes from Bob Boyce who is easily the most experienced hydroxy user and investigator on all of the forums. That figure relates to Bob's hydroxy which is the highest possible quality and most people never manage to get anything as high-energy as Bob's gas output. The information

comes from repeated experiments by Bob who just lets the pressure build up and then notes the pressure at which it explodes inside his container which is strong enough to withstand the explosion.

Q: Thank you for your quick reply. I am due to meet with Bob Boyce next week. I hope he will have the time (and patience) to deal with my newbie questions but I intend to drill down on this turbocharger thing. For my project, it's mandatory that I run with a turbo, and mandatory that I can feed the maximum amount of high quality HHO. This engine will be developing 400 hp with 13 lbs boost. I think I'll be defeating my purpose if trying to push maximum amounts of HHO into the low pressure side of the intake. First, it will partially displace the necessary air for combustion. Second, it has a torturous route to travel. Third, it will no longer be monatomic HHO when it finally reaches the engine. There must be a better way.

That's why I was hoping to experiment with a medical diaphragm compressor (same as they use to store hydrogen). If I can blend some outside air with the HHO prior to compression, maybe Bob can tell me what ratio of air/HHO to offset/raise the self-ignition. I'm only looking for 20 psi so maybe the dilution won't be a big deal. Anyway, I'm trying to maintain the purity of the HHO prior to engine combustion.

A: Bob Boyce, who is a very highly experienced hydroxy researcher, states categorically, that you should use the low-pressure side of the turbocharger. I am reasonably certain that there is no need for you to pre-mix the hydroxy and air as that happens adequately during the normal intake process, but Bob can certainly give you much more specific detail on this than I ever could. The pressure for self-ignition is raised enormously when the hydroxy is mixed with air, so it should not be a problem in your case.

The objective is to extract a higher proportion of the energy contained in the normal hydrocarbon fuel, and not to add in energy produced by the combustion of hydroxy gas. That being the case, the amount of hydroxy does not have to be enormous for there to be a very significant gain in engine power and thrust quality. Again, Bob is the man to give you the specifics. Good luck with your project, and I hope your visit to Bob works out well.

Question:

I'm spending my day watching YouTube videos of Bob Boyce. It seems every minute I'm learning more and more. Big problem for me is (-40) cold weather and freezing of the water when not in use. (Canadian winters are brutal). The bubblers can be filled with KOH, no problem there. Same with the main cell if I use KOH. But the biggest problem is the water reservoir and supply lines. I had thought of 50/50 blend of methyl hydrate/water (windshield washer fluid) but, according to one of Bob's videos, the carbon will bond with the nickel in the stainless steel plates and eventually stop gas production (sigh). If I had a consistent and reliable electrical power source, I could just plug in a heater of some fashion, but I won't always have that luxury. Any thought on the subject??

Answer:

Please do NOT put KOH in your bubblers as a major function of the bubblers is to wash all traces of KOH out of the gas before it reaches your engine as traces of KOH are not good for your engine. You can use alcohol or paraffin ("kerosene" in the US) which many Canadians have found satisfactory in bubblers as the fumes are not harmful to your engine in any way. If you are boosting, then the water usage will be so low that you can manually top up with warm water from time to time.

Question:

I have watched the interview of Bob Boyce with Chris Patton countless times, even now, looking for signs of 'bullshit'. I have a good intuition which I trust and listening to Bob I can't help but like the guy and still believe every word he says. I'm a plumber and have no previous experience with hydrogen. I've built a 101 plate electrolyzer following your plans and I'm getting 4 lpm when using 190 volts DC and about 4 amps of current.

I've wound my toroid and just run out of money for a scope to try to get the resonance. I've noticed that no one seems to have ever replicated what is described on your website and that Bob is copping it on the forums. I believe him still, but I was wondering in your opinion why is it that no one has managed to get 50 lpm or anything mind blowing? Where could the problem be? I'll tell you one thing though, I'm gonna keep at it as soon as I can afford a scope.

Answer:

Resonance is very important in any COP>1 system, which is what Bob Boyce's hydroxy system is. I'm not sure about your need for an oscilloscope, but don't let me discourage you from getting one. If you have not seen them, the series of YouTube video clips on resonance <http://www.youtube.com/user/gotoluc#p/u/15/L0AZkovLTT8> should be both interesting and helpful.

Dave Lawton has designed and tested a circuit which finds and locks on to the resonant frequency of his style of cell. That circuit is available as a pcb, a kit, or a ready-made unit from Courtierstown Marine in Aberdeen.

However, Bob Boyce's design calls for three drive channels instead of just one. Bob has designed, built and tested what he calls his "Hex Controller" which is probably a PIC chip programmed device. He has kept it secret while he applies for a patent on it, but it should become commercially available shortly. I understand that like Dave's design, it locates and locks on to the resonant frequency of the cell.

When not tuned to resonance, the pulsing system should give about three times the gas output of the DC cell performance. When tuned to resonance, the increase should be five or six times.

As you are probably aware, the electrolyser needs to have the plates cleansed and conditioned as described in the D9.pdf document on Bob's unit. Then the cell needs to be "run-in" on DC until it gives around twice the Faraday output. After that, the unit is filled with 28% by weight KOH electrolyte and fed the pulsing signal.

Faraday defined electrolysis as being 2.34 watts per litre per hour of gas output. That is $2.34 \times 60 = 140.4$ watts for 1 lpm of hydroxy. At this time, you are feeding in 4 amps at 190 volts which is 760 watts. For that 760 watts Faraday would expect 5.41 lpm, which means that your unit is running at 74% Faraday, or about one third of the expected output from Bob's design before it is ready to go to pulsing operation.

Admittedly, the 190 volts is fractionally low for 100 cells, but it is close enough not to be any problem. So, at this point in time, your cell needs mechanical attention in order to get up to the 11 lpm or so that can be achieved on DC alone. When it reaches that level of performance on a 10% NaOH solution, it should then achieve 33 lpm or more with untuned pulsing. But the first step is to get the cell to it's necessary DC performance level, which, unfortunately, probably will need the plates to be prepared to a higher degree.

Unfortunately, there is a difficulty with Bob's design and that is that the plates need to be positioned and sealed to a degree well beyond the capabilities of the average person to construct. If you bought your case from Ed Holdgate, then there will be no problem, but a home-made case can't generally be constructed to the necessary 1/3000 inch accuracy by the average person, as that is a skilled job for an expert machinist who needs to know the exact, actual electrode plate thickness before he starts making your box.

The need for that extreme accuracy is because the resonant operation sets up a magnetic waveform inside the plate array and that won't happen unless the plates are positioned VERY accurately. The gas bubbles form in the electrolyte between the plates rather than on the plates and when that happens it looks like the electrolyte is boiling although it is actually quite cool. I'm sorry that my reply has to sound so negative especially since you will already have put in a large amount of effort on your project. Good luck with your upgrades

Question:

You must be busy, but I'd appreciate any feedback about this link:

http://www.pureenergysystems.com/news/2005/03/17/6900069_Acetone/ Would you say engines in good condition get improvement, or the opposite? In you opinion, could I damage a diesel tractor engine, or car gasoline engine by trying small amounts of acetone added?

Answer:

There was a lot of discussion about acetone some years ago. Some people got around 20% mpg improvement while others got no improvement at all. It appears to depend on the engine and the condition that the engine is in when the test is run. You need to understand that I am not an automotive expert and so my opinion does not count for much. I would expect it to be the older and poor-condition engines which would benefit most from acetone - which, incidentally, is a fairly dangerous substance for humans and needs to be handled with considerable care as it can be absorbed through the skin and by inhalation and it can cause kidney damage.

I don't think that you will damage any engine by adding some to the fuel. Having said that, you can get up to 60% fuel reduction on a diesel engine by adding hydroxy gas in sufficient quantity and petrol engines respond even better than diesels. The GEET device allows a major reduction in fuel use and is very popular in France where many tractors use it. The <http://www.panacea-bocaf.org> web site has a good deal of information on it and are experimenting with it at this time. There are also two GEET enthusiast forums.

Question:

I have a Ford "Transit" diesel 70 hp manufactured in 1995. Is it possible to add hydrogen in order to let it run with less fuel consumption and be more environmentally friendly?

Answer:

The fuel consumption of a diesel engine can be reduced by anything up to 60% by adding hydroxy gas to the incoming air. As far as I am aware, no modification to the engine is needed. The improvement in fuel consumption is proportional to the amount of hydroxy gas added. I hope that this helps and good luck with your project.

Question:

Hello, we need your help. Based on your 6-cell model of Chapter 10, we have built such a generator, which is as follows:

- Stainless steel type 304 (do not get the 316), calibre 0.08.
- Badges 4 "1 / 4 X 2", 4 plates per cell, total 24 plates (206.4 in²).

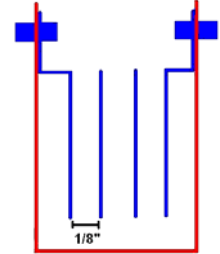

NaOH was used as electrolyte, with a concentration of 20% (as described in chapter 10), we just apply 13.5v a current consumption of 1.5A. We use a higher concentration of electrolyte at 30%, 40% and gave us the same result with a current consumption always similar to 1.5A. We need to know because consumption is so low that, according to calculations based on Chapter 10, current consumption with 12V, it should be up to 40A. Or have we miscalculated? See attached image.

Answer:

You have invented your own plate arrangement which needs 6 volts per cell because you have 3 (very inefficient) voltage gaps inside each cell. At this time, you are applying only 0.7 volts between each pair of plates and that is why the current does not change much with stronger electrolyte. You need to change the plate arrangement to what is shown in this drawing. Good luck with your project.

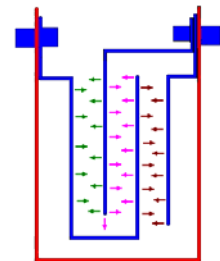

Question:

In the WaterFuel1978 Yahoo forum, the contributor "s1r9a9m9" says that he runs his large capacity car which has 8-cylinders, using just water and an inverter. Do you know of anyone who has replicated this?

Answer:

I am reasonably sure that Nathren Armour is a professional con artist, paid to mislead people investigating how to run an engine on water. "s1r9a9m9" (Nathren Armour of the USA) came on the scene about four years ago. I didn't believe him at all, so I asked him some questions by direct e-mail. I was very surprised when his answers were quite convincing. This was in the old "egaspower" forum. So I wrote a document drawing together all that he had said about the design and adding in each relevant post by people in the egaspower forum who tried to understand and build his design.

After two years of intensive experimentation by several competent people, there was not the slightest success by anyone. Because of this, I withdrew the document "D13.pdf" (although there are probably copies still floating around). I no longer believe that anything Nathren says now, or said back then, is true. In the early days, he posed as an uneducated country car mechanic, who for some unknown reason, was asked by NASA to make some component for a mission to Mars. Why NASA should rely on a country car mechanic is not at all clear. At that time, he told me in a direct e-mail, that he had converted his own personal car, and the engine out of a truck which he used to power an electrical generator, and the cars (plural) of his friends.

His car has 8 cylinders, the truck at least 4 (though probably more), at least two friends with four cylinder cars, makes a minimum of 20 relays needed, plus one which he took apart to see how it was made, so say 21 although 27 would be a more likely number. When writing at that time, his posts were written in broken, uneducated English with a space before the full-stop at the end of each of his sentences.

Now, his posts are in much better English, the gap before the full-stop has gone and the relay count which he states, contradicts what he told me by a really major factor. He no longer allows for the relays used for his friend's cars, or the one which he supposedly took apart. Any time he was asked for specific information, he always made unconvincing excuses and supplied no worthwhile data.

He has posted videos of the Steorn device, showing bench test equipment of a type which no country car mechanic would ever own or understand. His videos have sound but he does not say a single word, which is

most unusual for an English speaker, and in this case is highly suspicious.

My opinion is that his information is wholly fake. It is distinctly possible that this con is now being carried on by a second fake "Nathren Armour". I have never heard of anyone managing to replicate any part of his supposed invention, and I doubt that anyone will ever manage it, although I would be delighted to be proved wrong.

It is perfectly possible to run an engine of any size on what appears to be water alone (the engine actually runs on stored energy drawn directly from the local environment, coming mainly from our Sun). I know of several "petrol-powered" electrical generators which have been converted to run on water in spite of the fact that the efficiency of their tiny internal combustion engines can be as low as 10%. Some of those generators have been running continuously for more than two years now.

Running a large engine on water alone is a much more difficult task but it can be achieved by the energising and injection systems of Stanley Meyer. Sorting out a system of that type has been quite difficult as Stan developed many different types and styles of adaption and it was not immediately clear to me, which of his descriptions apply to which of his systems. Additional information from the contributor whose ID is "H2Opower", has been most helpful, and Stan's design is now much more understandable, which means that replications are now a distinct possibility.

Question:

My daughter came to visit from California. She got 27 miles per (US) gallon average on the trip up here with her Buick Regal. For her return trip with a full car load of her stuff I installed an improved (single water bath) electrolyser, current control with a BASIC Pulse-Width Modulator, and I made her a MAP sensor enhancer override. She followed the same route back to California and averaged just under 40 miles per gallon (a 45% increase). No other changes were made. The electrolyser has eight 2.5" x 5" stainless steel plates with 1/8" spacing in a Mason jar. The plates were all cross-hatched with sanding score marks and all skin oils were removed with trichlorethylene (Automotive Brake Parts Cleaner). I used the method Boyce recommended of polarizing the plates with a wire wrapped around the body of the plates and sparking across a 12 volt DC source. I set the Pulse-Width Modulator to supply 18 amps steady once warmed up. Previous to this project the best I had achieved is a 23% increase. Your book helped me to tweak a few things and waah-laaaah 39+ mpg.

I do have one problem which I've been trying to figure out. I am building a Don Smith type device. The unit he showed is rated at 8,000 volts at 20 amps (160 KW). I used a 10 foot section of #12 solid copper wire for the L2 coil wound around a 2" pvc pipe. I then released the hold on the wire allowing it to expand to approx 3" diameter coils. Then I cut four ABS plastic strips and hot glued them into the interior of the coil spaced evenly. The coils are spaced at 3/8" space per turn. I then used insulated #12 multi-stranded (maybe 50 strands) wire 2.5 feet long for the L1 coil wrapped around a 1.5" PVC pipe which made about 5 and 1/8 turns. the excess wire was run through holes into the centre of the pipe and carried through to near the lower end to exit the pipe and was then led to the terminal strip for the neon generator.

The neon generator throws a 2" spark until it is hooked to the coil. Once the L1 coil is hooked up I can't get the slightest spark! The spark gap will not arc even a 64th of an inch. I've tried rectifying the output of the neon transformer and tried direct hook-up. It seems odd to expect that a spark could be drawn with the L1 coil direct shorted across the transformer output. My understanding is that the spark gap is required to maintain the frequency as a trigger when DC is used, but that it is not absolutely necessary with AC. Is this your understanding? I know from Tesla's drawings that he commonly used them, but often it was after a capacitor.

When I was looking at the photo clip of the device I didn't see any diodes. Could they be in the black insulating tubing on the terminal strip? Do you know why he converts to DC before he goes into the coil, when he again rectifies with a bridge after the L1 / L2 coil assembly? Could he just as well be using AC until he completes the zero-point energy collection process like Tesla often did or are you positive he has diodes in there at the neon transformer?

One last thing... Do you know how I can read the frequency of the neon's High Voltage High Frequency output with an oscilloscope? I tried to contact the sellers of the devices and they have no idea what the frequency of the output is. They just read what the data plate says on input frequency. I am now trying to get the info from the manufacturer, so far unsuccessfully.

Answer:

May I suggest that you hold off on your assessment of the improvement in mpg got by your daughter. Some ECUs are programmed to adapt to changes such as the addition of hydrogen, and after a few days or weeks, revert to pumping in excess gasoline. Let's see what the effect is after some time has passed. Certainly, the improvement achieved so far is a good indication of what is definitely possible in spite of the opposition from the ECU.

I'm afraid that the suggestion on wrapping wire around the plates and pulsing it, came from me rather than Bob Boyce, who I understand thought that it was a ridiculous idea until one electrolyser builder told him that he had got a substantial percentage gas improvement by doing that. In theory, if the steel is perfect, then it would have no effect, but if, as can happen, the steel supplied is not perfect, then it could help, especially in the early stages of electrolysis.

The devices described by Don Smith are probably the most difficult you could try to replicate (with the possible exception of the Joe Cell). Each of Don's devices need to be tuned to resonance which is difficult to do unless you have a lot of patience, equipment and know-how. Your construction method sounds great and your choice of materials, very good - most people ignore what they are told and decide to do something else and then say that "it doesn't work", while in reality, they should be saying "I couldn't get my altered design to work".

In my opinion, the spark will not occur unless you have a capacitor across the L1 coil, forming an L-C combination which has high impedance at the frequency produced by the neon driver circuit. On it's own, I would expect the L1 coil to load the neon supply too heavily to get any serious voltage across it. As an L-C pair, the impedance at one particular frequency will be very much higher (which is how an AM crystal set radio receiver tunes in a particular station). The spark will only occur at resonance as the voltage will be pulled down too low at all other frequencies.

The diodes are hard to see in the video. They are long and black and don't show up well against the dark background. There are actually four of them on the output side and as you correctly remark, Don describes them as a bridge. They are very long because of their high voltage rating, perhaps ten times as long as they are wide.

I think that the neon driver which Don had, gives two separate high voltage outputs and Don combines them on the input side of L1 with two diodes to stop them interacting with each other. Your neon driver circuit is liable to be very different to Don's.

The frequency and shape of the neon driver output pulses can be read with an oscilloscope. You set the horizontal time adjustment so that you have two successive pulses widely spaced on the screen, and then the horizontal timing setting combined with the number of squares on the screen between the start of each pulse shows you how far apart in time the pulses are. If the time between them is 0.033 milliseconds, then the number in one second (which is the frequency) will be the number of 0.033 milliseconds which fit into one second (of 1000 milliseconds), i.e. $1000 / 0.033 = 30,000$ pulses per second or 30 kHz.

Topic: Magnetic Motors

Question:

If a Flynn Magnet Motor has an even number of magnets and coils on the Stator, how does the motor self start when power is applied, if at all?

Would the assumption be correct that the position of the two magnets on the rotor would be slightly off the exact point of registration of their opposing coils in the direction of rotation, say by 1 or 2 degrees or less perhaps as power is applied to them? The next obvious question would be, how long does the energising pulse have to be? I realise it has to be long enough for the face of the rotating magnet to pass over the Stator magnet. After how many degrees will the rotating magnet be caught in the attraction flux of the next magnet? This period of the coil being energised must obviously be as short and effective as possible, since this will determine the input power.

You state in the literature that the two opposing coils, 180 degrees apart are driven in series. What's the reason for series instead of parallel? If current consumption is the problem, then an adjustment in coil design could easily make a parallel connection draw the same current as a series connection, no?

I know this is not a reasonable question but one I wish to ask anyway. If a motor with the magnets I propose to use, works and works well, using a single platter with the specifications as they are, what could one expect in the way of output power, and what would the total input power be? IF and that is a big IF, this design could attain, even 6000 rpm, it could generate considerable power. If speeds of 20 000 rpm as claimed by Flynn are possible, then I guess even a small motor like this one, could in fact yield a heck of a lot of power !!

Answer:

Self-starting requires a different number of stator magnets or coils to the number of rotor magnets. If the numbers are the same and the stator has separate magnets rather than being one large ring magnet, then the rotor will stop in a position with exact registration of the magnets. So if the build does not allow the user to give it a starting twist, then an odd number of magnets are necessary.

I would suggest that you use an electronic circuit to control the length of the pulse but if that is not convenient, then I would suggest a twin-rotor optical method of adjusting the pulse length as shown for the timing of the Robert Adams motor in Chapter 2. By adjusting to position of the two timing rotor slots relative to each other it allows you to control the unmasked slot length in the timing disc and so adjust the pulse length passed to the optical sensor.

Connecting coils in series or in parallel is just a choice governed by the windings and the user's choice of current, as you point out. The point being made in the text was that being exactly opposite each other, the pulses occur at exactly the same time. However, as you point out, that arrangement would have starting problems.

The torque provided by a single rotor depends directly on the radius of the rotor from the bearing out to the centre of the magnets. Another factor is the pull provided by the permanent magnets. The final factor (ignoring the bearing friction and wind resistance) is the speed of the rotor as the number of drive pulses experienced by the rotor depends directly on the rotational speed. I could see the power output of such a motor as being substantial, even with just one rotor, and by adding additional rotors on a single shaft, the power level should be almost unlimited and I can see no reason why a standard electrical generator could not be driven by such a magnet motor. Remember that only one coil is powered at any one time.

Question:

Here is a question which I hope you can answer. I really have no idea why the coils in the Flynn Magnet Motor drawing have such a large area inside the windings. Obviously the shape of the coil follows the shape of the magnet, but why is the centre cavity so large? If the magnets are circular would there still be a large centre hole? I have noticed this in coils designed for wind generators as well. Your explanation would be appreciated.

Answer:

When a current is passed through a coil of wire the strongest part of the magnetic field which is generated is inside the coil windings. The gap inside the coil windings is the most electronically shielded area when the coil is activated and that is why the gaps inside the coils cover the majority of the stator area. This would be the same if the stator was non-magnetic and had circular magnets mounted on it. In that instance, the gap inside the coil would be the same size and shape as the stator magnet and might well surround it.

Question:

I am interested in experimenting with the Phi transformer. I have been reading your free-energy e-Book for quite some time now. You mention tests with a COP of 8.5, namely, 140 watts input and 1.2 kilowatt output. Would you assist by pointing me in the right direction in examining studies/literature on the Phi transformer.

Answer:

I'm afraid that I am just passing on the research information which I have come across, and I have not built and tested everything mentioned in the eBook as that would take a great deal of money and probably several lifetimes.

In the case of the Phi transformer, I only came across it twice. Once on a German website where there was a very nice photograph of an exceptionally well-built prototype and once on JL Naudin's website. Unfortunately, I lost track of the German site and did not take a copy of that nice photograph. I think that the performance figures came from that site. I tried e-mailing JL Naudin about the variation shown by him but he never replied, which I gather is not unusual for him.

I am not aware of anywhere else that carries information on the Phi transformer. Two people e-mailed me about their attempts to replicate it using very rough bent steel strips and spinning the rotor with a power drill. Their initial tests appeared to confirm that there was either very little, or no Lenz Law effect. They soon dropped me out of the loop and went on developing while communicating directly with each other. I don't recall ever hearing their final results but have the impression that they did not do very well. However, my impression of the quality of their construction and testing was that it was not great, and with free-energy devices, a high quality of construction can make a major difference.

Having said that, I would suggest that you pick on some other device with which to experiment and I would like to remind you that the eBook is upgraded about seventy times per year on average, so downloading another copy is probably not a bad idea.

One thing you might care to consider is adapting a generator to run on water alone as the excess output is in the kilowatts range and not much construction work is needed. Alternatively, if internal combustion does not appeal, then perhaps the RotoVerter which can give a 90% saving in the running costs of electrical equipment.

Hope this helps, and good luck with whatever project you pick,

Question:

I've got this idea for a motor and want your feedback. Say you have a wheel, and around the edge you place magnets having the same poles pointed outward. Maybe 30 magnets and all have their north poles facing outward on this wheel. One magnet is then brought, south end first, at right angles to the magnetic field of one of the magnets. The idea is that this will push the magnet in one direction and force the wheel to move, and because all of the magnets have the same pole exposed, this process of continually interacting magnetic fields should keep on for a while. Very possibly a crackpot idea. I'm getting 40 magnets shortly, each with a pull force of 11 pounds, so I hope they're strong enough to do something.

Answer:

It is very difficult indeed to get a permanent-magnet-only motor going and the setup which you appear to suggest is one which is commonly tried by almost everyone. It generally doesn't work because while there is a repulsion on one magnet which drives the wheel around, as soon as the next magnet on the rotor approaches, it encounters a backward push of exactly the same size and that causes the rotor to oscillate and then come to a stop with the magnets at their shortest distance apart. Using electric shielding to block the unwanted retarding action, as in the Adams motor or the Flynn motor, makes a major difference and can produce great results and high rotational speeds. Good luck with your experimenting.

Question:

Regarding the Orbo details in Chapter 1: What Sean at Steorn is saying is that the permeability of the ferrite core decreases as the rotor magnet approaches (I have verified that this assertion is true). When the permeability is at its lowest point, the coil is pulsed with a very small current so that complete saturation occurs. The ensuing small magnetic field then allows the magnet to skate past the ferrite core. Once the magnet no longer influences the core, a large change of inductance occurs in the core, and as Sean states, it leads to an "energy gain". At this point, the flyback voltage can be captured, and indeed, it is greater than the energy it took to energise the coil. The higher the RPM, the more energy can be captured. There are numerous factors involved in all of this, all of which are quite critical in achieving maximum performance -- coil positions, core permeability, speed, etc.

Answer:

Thank you for the detail on the Orbo design. I find it quite hard to get excited about it due to the earlier Adams and Flynn motor designs. I am more than happy that the people in Dublin are genuine as that was my strong impression when I met them on the first day of the failed London demos.

We are only scratching the surface here. I have had person-to-person information on the Adams motor, information which I think has never been made public. Robert Adams was not willing to share his more advanced developments and died before he decided to share his findings. I am informed that he had got a 200 mm diameter rotor motor/generator up to megawatt level output, which is pretty spectacular. I wonder if we will ever replicate that performance.

I understand that Chas Campbell in Australia reached COP=10 before moving on to a more advanced design which he says has unlimited energy output. He says:

"How 2 Fix

To create a power source by using Gravity you must have a constant source of momentum and it doesn't have to be perpetual motion, My system uses an electric motor to generate centrifugal force this is achieved with flywheels. A balanced flywheel attached to an electric motor will actually reduce the power consumption of the electric motor while generating Torque, and you use that extra power to drive another flywheel and so on. Remember, to produce electricity you only have to spin a alternator at its designed speed once that speed is reached you use the torque (hp) to keep it spinning - sounds too easy doesn't it? I can spin a flywheel which weighs 80 kg, at 1,000 rpm and the power consumption of the 750 watt motor is less than it takes to spin the motor when it is attached to nothing.

As a matter of interest, the flywheel has a diameter of 600 mm. Imagine a steel wheel weighing 80 Kg travelling at 113 kilometres per hour. So the next time your electricity bill arrives, ask yourself "why does it cost so much when it can be produced by Free wind, Free sun, Free tides, Free water and Free Gravity which can be produced on site?" No more power lines or high insurance cover needed on your solar panels or wind towers.

Gravity is available everywhere even to the 2+ billion people who live without electricity. I am not smart enough to write a book or design a computer game so I decided to invent something that would make me rich it's been a lot of fun and very frustrating as everybody keeps saying "it can't be done". I am now 73, live in a unit, have a foreign landlord and have spent all my money on my invention. It's time that I told the world how to build the "Safe, Affordable, Helpful, & Clean" generator.

Sir/Madam if you, your company, or your Government would like to be associated with something that will make the world a better, safer place please contact me. I've had a film made that I'm sure you will find very interesting.

If you send your POSTAL ADDRESS with a small amount to cover my costs to my POSTAL ADDRESS, then a copy of the film in DVD mode will be posted to you.

Sincerely,
Chas Campbell
PO BOX 137, Sunnybank, Queensland, Australia 4109."

It looks like Chas has hit the same brick wall of "zero funds" that most other inventors have. He also seems to have been bitten by the "hey, this design is worth a lot of money, so I could get rich here if I play my cards right" bug. If he manages to make big money, then he will be the first inventor to ever do it.

Question:

How can I block the magnetism between two strong magnets for my new magnet motor design? I am using five layers of mu-metal at the moment but I need a complete magnetic block.

Answer:

Your question suggests that you do not fully understand the nature of magnetism, which is not too surprising as it is not really well taught anywhere at the present time.

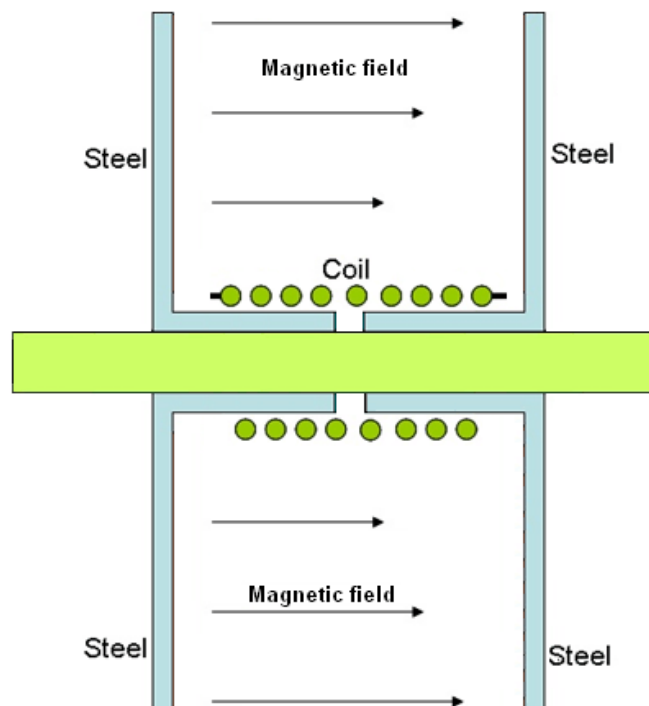

If you place two circular steel flanges on a plastic shaft, wind a coil on the plastic shaft and power the coil. the resulting magnetic field is strongest between the outer edges of the flanges and weakest at the coil of wire. Unexpected, but true. The reason is that magnetic "lines of force" (for want of a better term) spread out along the paths of least resistance and the flow divides up in direct proportion to the resistance of the paths. Steel has 1000 times the magnetic conductivity when compared to air, so for every 1 unit flowing through the air, 1000 units will

flow through the steel if it provides an alternative path. As the flange diameter increases, so does the area of steel in the flange and hence the magnetic conductivity. The result is that the strongest magnetic field between the flanges is at the outer edge as can be seen from the attached diagram. There IS additional magnetic flow (not shown on the diagram) through the air outside the flanges, but it is very small compared to the flow directly between the flanges.

The bottom line is that it is not possible to **block** magnetic flow with a shield (and mu-metal is one of the very best materials for attempting that). The most you can do is to provide a more attractive flow path for the "lines" of magnetic force, and so persuade them to divert to another direction - they never just stop at a barrier.

So, for your problem, I would suggest just two ways of dealing with it:

1. Use an identical magnet as the "shield" but reversed so that the field oppose each other. That will work, but if your design requires the shield to be moved into position, then there will be a very marked overhead of the force needed to move the magnet against the existing magnetic fields.

2. You oppose the magnetic flow with a magnetic field from a coil, the field only being present when the coil is being powered. That is very effective and the motor power is very much greater than the mechanical power which could be generated from that same electric current. That arrangement is called a Flynn Motor and it works very well indeed.

One other option which does not match your query, is to physically move one of the two magnets relative to the other as is done in the Steven Kundel magnet motor.

Good luck with your project,

Topic: Don Smith's Devices

Question:

I am a bit confused though by the frequency conversions necessary to find the proper length of coil for an L1 coil. On page 338 of PJLBook.pdf it says...

Point 1, section d "If using one quarter wavelength, then divide 247 by the frequency in MHz."

My frequency reads 35.4 KHz or 35400 Hz. That calculates out to .035400 MHz. If I divide 247 by .035400 I get 6,977.40112994 feet. In reading the examples given in Dons pictures and text no reference is given to use of anywhere near that length of wire. In fact the reference to length is in the ten foot range. Am I way off base here or what? Do you come up with the same figures? I have to be missing something, can you help me see it?

Answer:

You are not the first person to ask me that question. It needs to be understood that you are quoting Don Smith and not myself. You should also understand that Don Smith does not reveal everything about any of his designs and I, personally, do not by any means understand all that he says. The Don Smith devices are some of the most difficult to understand and replicate. Don uses various techniques with his different designs although most of those techniques appear to have a common background strategy for energy extraction from what he describes as "the ambient background" and others call "the local environment".

Don goes into the overall principle for estimating the resonant frequency of a coil, where a factor of 247 comes into play. However, a coil and capacitor combination resonate at a different frequency set by their combined characteristics. This is clearly seen in a "crystal set" radio receiver. These very simple receivers can be tuned to a radio station by adjusting the number of turns on a coil. The coil is generally built like a rheostat with a slider connecting to each coil wind in turn.

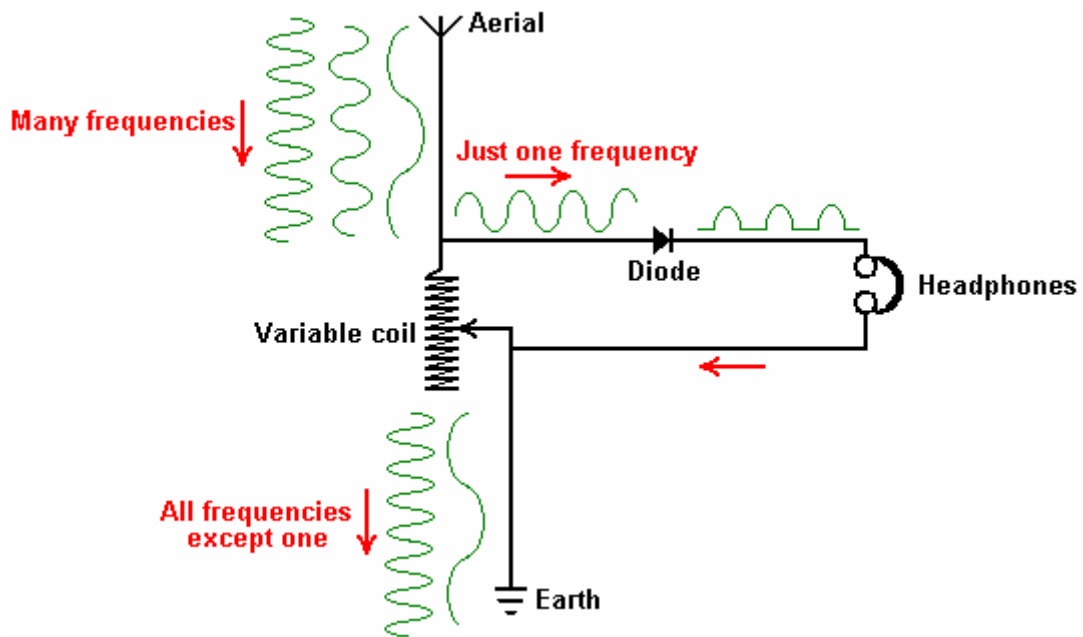

The tuning relies on the fact that a coil of any particular characteristics such as length, diameter, core material, turn spacing, etc., has one frequency at which it has a very high resistance to AC current flow through it. While we don't tend to think of it as such, a radio signal coming down an aerial wire heading for an earth connection, is actually an AC signal causing an AC current in the aerial and earth connections (and consequently, the coil connected between them). If there happens to be a radio signal which is at that exact frequency, then it finds it very hard to get through the coil and tries to find an easier way past the blockage. The radio builder provides that easier path by connecting a germanium diode and a pair of headphones across the coil. Only that one radio signal takes a detour through the headphones and so the listener only hears one radio station out of the many coming down his aerial.

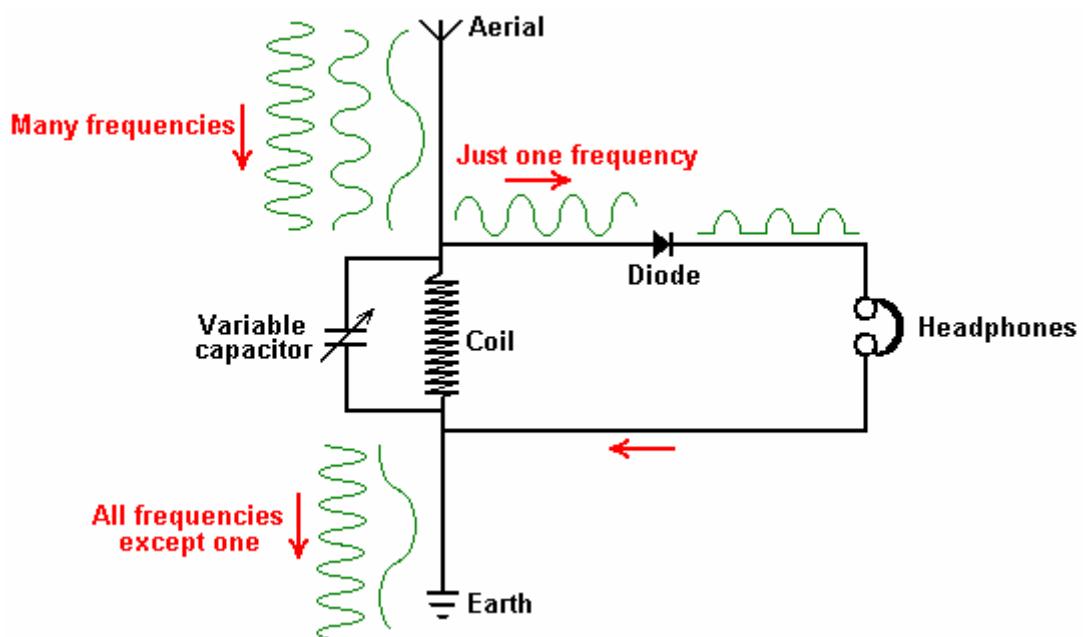

An alternative construction is where the set is tuned by adjusting the setting of a variable capacitor connected across the coil which has a fixed number of turns. This adjustment causes the coil/capacitor combination resonate at different frequencies, the frequencies of interest are those used by different radio transmitters. The average person thinks of this as "tuning the radio in" to different radio stations, but the reality is that the user is altering the resonant frequency of a coil/capacitor pair. The higher the required frequency, the smaller the capacitor needed.

If a coil has its turns spaced out like the Barker & Williamson coils which Don uses, the coil's inherent self-capacitance is increased dramatically. Dealing with coils energised at high frequencies is a fairly tricky area as there is stray capacitance through the air between components on a board, and so, the physical layout of the

circuit becomes a factor in the design and in some instances, placing your hand near the tuning components can alter the stray capacitance of the tuning system.

Don admits freely that he does not reveal all of the details about any of his designs, but he does share enough for enthusiasts to have a reasonable chance of working out the missing details for themselves. To help with this, he explains a couple of his easiest designs in fair detail. The neon tube driver design is one of these. Here, the frequency of the commercial driver circuit is imposed on the small "L1" primary coil winding. If it is not the natural resonant frequency of the coil, then circuit forces the frequency on the coil by pulsing it at that frequency.

However, one thing which Don does not mention is the fact that the current which will flow through that "L1" coil depends on the applied voltage (which is very high and might be 6,000 volts) and on the coil's impedance at that frequency. The practical details of this radio-frequency work is something about which I am almost 100% ignorant, so you would need to read up on the subject or consult an experienced radio-frequency expert.

In the design which Don shows most frequently, he indicates that the performance of the first part of the circuit is governed by the resonant match between the L1 and L2 windings of the Tesla Coil which he uses to step up the voltage to a high level. To make these two coils resonate in step with each other, the L1 coil needs to be made from wire which is exactly one quarter of the length of the wire in the L2 coil. If the coils were the same diameter, that would give a 1:4 step up in voltage, but as the L1 coil has a larger diameter, the wire length makes fewer turns than one quarter of the number of turns in the L2 coil. Consequently, the step-up ratio is more than 1:4 and more than four times the voltage is generated in the L2 coil.

Don implies that if the coil winding is not absolutely exact, you might need a very small capacitor across the L2 coil in order to make the two coils resonate at the same frequency. If this were the only requirement then you would expect to see one capacitor across the "L2" coil to make the matching perfect. However, you will notice that Don uses a capacitor across **both** of the coils. So, why does he need two? This may be my ignorance showing here, but I would suggest that the capacitor across the "L1" coil has nothing directly to do with the "L2" coil at all but is there to tune the "L1" coil exactly to the output frequency of the neon-tube driver circuit, presenting it with a high impedance at the working frequency and so it will draw very little current from the driver circuit.

The frequency in L2 will always be the same as that in L1 which is driving it, but the energy performance is massively better if the L2 coil is operating at its own natural resonant frequency. This may well be achieved by the wire length ratio between L1 and L2 but as the L1 natural frequency has been manipulated slightly by putting a small capacitor across it, I suggest that the capacitor across the L2 coil is to match the capacitor-induced shift in resonance of L1.

In versions of this design, Don converts the AC coming out of L2 to DC with a high-voltage four-diode rectifier bridge and then feeds the power into a large high-voltage capacitor before stepping the voltage down and the current up, with an "isolation" output transformer.

I have seen it said by several different people that a capacitor used like this causes a change in the nature of the incoming energy, making it much more like conventional electricity.

It seems highly likely that what Don says has a typing error and the "MHz" should read "kHz" and the wire length at your 35.4 kHz would then be 6.9774 feet (not including the straight connecting wires) or 6 feet, 11 inches, and 23 thirty-seconds or 2127 mm. Wound on a 3" former with wire of 0.25" diameter, that would be about 8.22 turns which does not seem unrealistic.

However, bottom line, you have to consider me to be a source of unreliable information here as you are asking me to interpret what Don means and there are probably not many people who can do that and I am definitely not one of them and so have to resort to guesswork here.

With regards to the Ecklin-Brown style motor-driven rotor device, I would suggest that although he does not show it or mention it, that Don tunes the power pick-up coils to the resonant frequency of the pulsing produced by the rotor arms passing by the magnet pairs. Remember that the title of Don's document is "Resonant" Energy Methods and he shows the Ecklin-Brown style device in that document.

Question:

Just to let you know I was at first impressed with Don Smith's research. Having checked other comments about him I now have my doubts. The question is: why did he not commercialise his Tesla system which is described in sufficient detail in your eBook? One of the sites I found did not have good things to say about him. Who does one believe. I sent him an e-mail recently and it just bounced back. It seems that Don has gone quiet.

Answer:

Don Smith is very elderly at this point in time and he has suffered several severe strokes. It is almost certain that he is in no fit state to respond to e-mails. There is a web site set up by his son who gives every appearance of not understanding anything much about his dad's technology.

Don methods are some of the most difficult to replicate as he freely admits that he withholds some vital information because he exploits his designs financially and so Non Disclosure Agreements get in the way. In his various video lectures he remarks that it is not in his financial interests to disclose all of the details but he says that he discloses enough to allow an experienced developer deduce the missing parts and fill in the gaps for himself.

Probably a key point is having the "L1" / capacitor combination reflect a high impedance at the frequency of the driving circuit (probably a neon tube driver). With a high impedance, there is little current draw. Another feature is the need to feed the energy into a capacitor before attempting to use it for "useful work" as the nature of the energy changes in the capacitor and aligns it to our everyday power supplies. The radio frequency experts have a head start in understanding Don's designs as they are nearly all based on high frequency and, for example, RF experts know that metal can be used to insulate between two wires if the spacers are the correct length for the frequency used.

Although Don does not say it, it is probable that his Ecklin-Brown style device has the output coils tuned to the frequency produced by the spinning rotor arms. Also, it is likely that he is using wire with a very large number of fine strands inside it and that seems to have quite an effect on the output.

Question:

I took off from the internet PJK book. I am interested in the device by Don Smith. Unfortunately, since my English is bad, and his logic is a bit different than my Croatian language, I have problems with understanding. The problem is on page 223, chapter 3-37. So I do not understand why I have to divide some numbers with frequency in order to get the length of the wire. For example, if I want to get the wire length in meters for one-quarter the length of the coil, why do I have to divide the number of 75.29 with the desired frequency. What does that number - 75.29? Also I am interested in one quarter wavelength? What do you mean by the term wavelength? Also, do you think that the term quarter means the length of the wire or it means the length of the coil? I counted the number of turns in the coil of Don and concluded that the coil L1 is a $1/4$ of $1/2$ of the coil L2. Can you help me, please, to understand it.

Answer:

Your question is not easy to answer, but I will try to answer it.

If you hit a church bell with a hammer, the bell will vibrate and produce a musical note which depends on the size of the bell. That bell always produces the same note when it is struck.

The bell produces a waveform in the air very much like the electronic waveform produced by most electronic devices.

The note (or "pitch") produced by the bell has a 'wavelength' which is determined by how many times it vibrates in one second and how fast the signal moves away from the bell during that second. The "wavelength" is the distance travelled by the sound during the length of time which it takes for a single vibration.

In electronics, a coil of wire has a resonant frequency, just like the bell has. At that frequency, the coil will vibrate with the minimum amount of input energy possible.

The wavelength of the resonant frequency of the coil is the distance which the electronic signal travels in the length of time needed for just one cycle of it's vibration. Electronic signals generally travel at what is called 'the speed of light' and believed to be about 299,792,458 metres per second. If the coil is vibrating 30,000 times per second (30kHz), then the wavelength will be about $299,792,458 / 30,000$ metres or about 9993 metres.

As far as I know, the number quoted by Don Smith is a fixed relationship between the length of wire in a coil and the wavelength of the coil at it's resonant frequency. I am not expert in radio frequency technology, so my explanation of that number may not be fully correct.

A very good resonant ratio between the primary coil ("L1") and the secondary coil ("L2") of a Tesla Coil is 1:4 which means that the length of wire in the secondary coil should be exactly four times the length of wire in the primary coil. That automatically gives the quarter wavelength ratio without you needing to know what the actual wavelength is.

In Don's case, he takes the frequency generated by his neon-tube driver module, and uses the number which you are asking about, to calculate the length of wire in a primary coil which will require the lowest possible amount of current to make it vibrate. That is, the coil's resonant frequency of vibration will match the neon-tube driver module frequency exactly. Other wire lengths will work, but the very best length is the one which he calculates. I hope this helps in spite of the language difficulty.

Question:

in Don's air core coil builders guide he says for L2 wire length at 1/4 wave - divide 247 by frequency. in his example it works out nicely at 10ft. My transformer is from 30 to 40kHz. lets say 35kHz to be in the middle. 35kHz = 0.035MHz (I think). so 247 divided by 0.035= 7057 ft! Now that's a wee tad on the long side me thinks! So I'm guessing that I can keep dividing until I reach a realistic coil length? Here's the question, for L2 to be in harmony with the 35kHz transformer output should I keep dividing the 7057 by even numbers OR by 247, or am I barking up the wrong tree completely?

Answer:

I don't claim to be any kind of expert on this stuff, but this is what I understand:

The heart of a Don Smith design is a resonant transformer. That transformer runs at high frequency and so it needs to be air-core. It can be either step-up or step-down. The lower voltage side needs wire of twice the thickness of the high voltage side. It is this transformer which is the ONLY part of the design which must be resonant and the resonance is between the two windings of that transformer, because at resonance (and not at ANY other frequency) the secondary becomes a room-temperature superconductor with no resistance at all.

To get that exact resonant match, either the length of wire in the turns of the thick-wire coil has a length which is exactly one quarter of the length of wire in the turns of the thin-wire coil OR alternatively, either or both of those coils has a capacitor placed across it so that the coil/capacitor combination has exactly the same resonant frequency of the other coil (or coil/capacitor pair if the other coil also has a capacitor wired across it).

If the two sides of that transformer are matched for resonance, then it doesn't matter what frequency is fed to the primary as the secondary will resonate with it. It is like striking a bell with a hammer. The bell has a specific resonant frequency and it will resonate at that frequency no matter how fast or how slowly it is hit with a hammer.

So, if you let your high-frequency power supply fill up a small high-voltage capacitor to some high voltage until it discharges suddenly through a spark gap (or neon or gas-filled discharge tube) and through the primary, that sudden voltage spike will generate a massive output in the superconducting secondary winding, even though the frequency of the sparks is not the resonant frequency of the primary coil.

The main problem is now encountered and that is the fact that the voltage and current in the secondary coil are ninety degrees out of phase. That means that when the voltage is high, the current is very low and when the current is very high, the voltage is very low, and so the output power appears to be very low even though it has the potential of massive output power. As I understand it, one way to overcome this is to wind the second half of the output coil in the opposite direction to the turns in the first half of the coil. That is, if the first half has clockwise turns, then the second half has counter-clockwise turns. The two ends are then joined together either with a high-voltage diode on both ends or without any diode. The output is then between the centre of the two-section coil and the two combined ends. This joining of the ends of the coil, combines the current and voltage outputs and that composite signal is then ready to drive the primary of an air-core step-down transformer to give lower voltage at higher current, ready to be rectified to DC or to have it's frequency altered by pulsing the output at the local mains frequency.

Chapter 3 has an attempt to explain this in fair detail, starting at page 46. Some people are of the opinion that the grounding wire and/or the connection to the load will alter the frequency of the secondary coil. I have no idea if that is so or not and experimentation is needed to check it out.

Good luck with your project

Topic: General Items

Question:

I was doing a web search today and came across your comprehensive book on free-energy devices. Since I've recently been introduced to this concept of the Zero-Point Energy Field, and still remain sceptical of a true Over Unity machine... I would like to ask if you have seen any such models working in person, with your own eyes? Something that runs without external energy input for an extended period of time!

If I were to replicated some of the experiments, is it easy to get in contact with those inventors? Have you been able to contact them and have had fruitful communications in the past? My curiosity is high, and I would highly appreciate your assistance!

Answer:

Thank you for your e-mail. I fully understand your caution in accepting something which you can't see and about which conventional science appears to be doubtful - calling it "dark energy".

I have met with just a very few of the people mentioned in the eBook as the internet allows us to talk freely to anyone around the world while getting together is usually VERY expensive and often almost impossible. I have met with Bob Boyce and Ed Holdgate in the USA and Dave Lawton who is in Wales. I have corresponded with many people around the world, including John Bedini, Tom Bearden, Ravi Ravu, Lawrence Tseung, Scott Cramton, Tom Thayer, Ron Pugh, Bill Williams, Lawrence Rayburn and a host of other people who have achieved COP>1.

Because of the fact that people are so scattered around the world, I have only seen "with my own eyes" two COP>1 electrolysis systems and one battery-charging COP>1 system. After much correspondence, I have not the slightest doubt as to the complete honesty of many of the people claiming to have working devices, many of whom do not want their names published and several who do not want any details of what they have achieved, disclosed in any way.

Many people think that those who claim these things are just seeking publicity while the reality is just the reverse with most wanting to be left in peace and many quite reluctant to share the details of what they have achieved. One of my biggest problems is that most inventors are driven by curiosity and when they succeed, they lose interest and move on to something else about which they are curious, usually taking the successful device apart in order to use the components for something else, and never documenting what they did.

Dave Lawton's successful replication of Stan Meyer's "Water Fuel Cell" had reached his spares box for recycling when he happened to mention it to me when talking on the phone. I then persuaded him to let me document it, and dozens of people have, since then, made successful copies of Dave's cell. Dr Scott Cramton worked on from that document and has reached 6 litres per minute of hydroxy gas for about 36 watts of input power (which Faraday would have believed to be impossible, stating the maximum possible performance would be 842.4 watts to get 6 litres per minute).

There is no way that I could convince you of the reality of the energy field, although I might be able to persuade you on devices which have a greater output than your input (your refrigerator for example which is COP=3).

Question:

I was looking through the "bedini_monopole3" Yahoo forum files for performances achieved, and most people have reported COP results of between 0.85 and 1.2 with a couple of wild results. Is this all you can get from a Simple Schoolgirl battery pulser?

If the recapture of Back EMF is central to COP success, then should we simply set up a coil, pulse it with DC, capture the Back EMF, making sure that the pulsing frequency is low enough to allow the coil to charge up? It seems too easy and too straightforward.

Answer:

The Ron Pugh Bedini pulser shown with photographs in the eBook has run at COP=11 with a bank being charged from a single battery. Few people construct to that quality or tune accurately like they should. Batteries are not a great solution and a generator running on water has massively greater use to a person - you won't get any battery pulser gaining more than 4 kilowatts.

Picking up Back EMF can be relatively straightforward. Remember the man in South Africa who charges up his 10 Amp-Hour battery each night using the battery which is being charged to power the circuit which is doing the recharging. That system uses Bob Boyce's toroid plus three diodes and one small toroidal choke. At the present time, that circuit recharges at just 12 watts (i.e. 1 amp of current) which is not a massive rate of recharging, but the overall performance is spectacular as present-day science says that doing this is "impossible" and yet this man has done it more than 35 times in a row.

I have a problem with batteries. To get the sort of current supply which a household needs, an impossible number of large, expensive batteries are needed. Even if you keep the rate of discharge down to discharging over the recommended twenty hour period, those batteries will need to be replaced on a regular basis. Also, batteries are not 100% efficient and so part of the current which you feed into them will not be returned to you when you need it to power your equipment. What is really needed is some alternative system which can generate the needed

power at the time when you need it. For that reason, while I am not a fan of internal combustion engines, a generator which has been adapted to run off water alone and which provides several kilowatts of excess power, looks like a much more viable solution to off-the-grid power.

Question:

I would welcome your comments re certain passages in Chapter 5. It talks about the load being powered indefinitely. However there are certain references to discharged batteries being restored under a minute and also that the batteries would charge up to nearly 36 volts with no apparent ill effects. After the discharged battery is restored after a minute this would seem to indicate that after one minute all batteries would start being overcharged. Does this matter? Is there any danger of damage, fire or explosion? There was some mention of control circuitry to prevent over-charging. If the circuit behaved itself during trials why would control circuitry be needed? Also, would not this compromise the correct working of this system? At the moment I am only thinking of using rechargeable batteries.

Answer:

Rechargeable batteries should be ok. John Bedini's "cigar-box" demo Tesla Switch used rechargeable and it ran for six months solid until it was smashed by the opposition who then intimidated John. The section in Chapter 5 which you mention is a quotation of what the Electrodyne Corp. people reported as their experiences with their implementation of the Tesla Switch. They were using four ordinary car batteries. I don't think that lead-acid batteries have any problem with over-voltage when they have become conditioned through Tesla Switch use for a month or two. The over-voltage protection was a suggestion from me and I believe that any problems which they had with the higher voltage were most likely to do with the voltage rating of the components in their circuit rather than with the batteries themselves.

Please be aware that the Tesla Switch pulser physical layout on stripboard shown in that chapter was corrected for an error very recently and so you should download a new copy of chapter 5 (or the eBook) if you intend to build from that particular layout.

Question:

I may have missed any discussion in regards to patents, so I would like to know if these are public domain, or what, if any, restrictions are involved in making one for oneself, or selling plans, or products.

Also, do you have a recommended parts warehouse? I am in the midst of searching, and would like to buy capacitors, chokes, and diodes from the one place. Any help you can give along these lines would be appreciated.

Answer:

Patents are documents of Public Record and so may be reproduced by anybody for any purpose. You are able to make anything shown in a patent for your own use. A patent has extremely limited power and is only there as a low-grade tool against competing commercial companies trying to outsell the patent holder. They can be used by rich and powerful individuals to harass and oppose the individual inventor or very small business by wasting a massive amount of time in court - time which should have been spent in production, and wasting vast amounts of money in defending against court cases (which may well be frivolous). Even if you personally, hold a patent on some device, you would need a tremendous amount of money to fight a patent application from someone else, even though the new application is clearly based on your design. Patents are only useful for very rich people.

There are links to electronics outlets on my websites, but you don't say what country you are in. In the USA, mouser.com might be a good source, while in the UK, perhaps ESR, Maplins or RadioSpares might be your choice.

Question:

May I ask what excess energy devices are there which have no moving parts?

Answer:

There are many devices of that type, with Don Smith having about four dozen, Herman Plauson describing aerial systems of his as being "small" if their output is not over 100 kilowatts, Bob Boyce's toroid which self-charges batteries, Steven Mark's toroid, the Colman/Seddon-Gillespie 1 kW battery, and many, many more.

Mind you, the ones with no moving parts are more difficult to get working as they usually need tuning and most people don't have the necessary level of patience (and many don't have the know-how either).

Question:

It appears resonance is the key to success. Although I have a background as an electronic technician, I am a complete novice regarding "free energy". I have been reading everything I can get my hands on. If you have any other informative references please let me know.

Answer:

The problem with the information is that different people have different theories on what happens and how it happens in the free-energy arena. Some people believe that it is electron spin while others believe that it is the ambient background being nudged into imbalance and others believe that the interface is through rotating magnetic fields.

It is distinctly possible that each of these views is correct and that there are several ways of tapping this energy. However, I can't point you at any one definitive text which describes it all in detail and explains how to gather and use it easily and cheaply.

We have been held back to the 1903 level of flight where flying is just not available to almost anyone. For us now, free-energy is just not available to almost anyone. Worse still, the internet is being smothered with legislation to curtail its use. Unelected people can dictate that any site is excluded from people in their country. The countries which have already implemented this are China, Australia and the UK and I think that the US is likely to do the same in the near future. I would expect my website to be in the list of excluded sites.

So, to answer your question, if I knew of any really good material on the subject, I would either have it on my web site or I would point to it. So sorry, nothing additional springs to mind.

Question:

I recently read with interest what you had to say about colloidal silver, but have I think found a problem! You state that in order to produce colloidal silver that it is necessary to use distilled water and that the silver rods are placed on opposite sides of the beaker. Well even at 27 Volts it is impossible to produce Colloidal Silver in distilled water with a electrode spacing of say 6.5 cm. So I ask, is distilled water really used or if it is anything else added?

Answer:

Highly distilled water is indeed used, and if you don't stir it, you can see streamers moving across between the electrodes. I have found the resulting colloidal silver to be very effective. Ravi in India uses the 200 cc container as he treats many people. I use a much smaller "snifter" glass whose internal dimensions are 40 mm tapering to 28 mm over a depth of 45 mm. This is because I generally use a nebuliser (or apply it externally which is really excellent for skin damage) and the dose volume needed is then very small, perhaps 8 cc or so.

I generally prepare the liquid for about 15 minutes and clean the silver oxide off the negative electrode twice in that period as it builds up very fast. The positive electrode goes non-reflective grey. I could only get much smaller diameter silver wire and so I use about eight strands on each side, bent back on itself in a vertical bundle, in order to get greater surface area.

Question:

There are so, so many areas of possible research that the challenge, for me anyway, is just in making the decision on what to try. There are two that I think I'd like to take a stab at:

1. The Tesla Switch.
2. The Stephan Leben circuit (base upon the original of Alexander Meissner).

However, I have a question concerning each of them. For the Tesla Switch, I've read that an electro-mechanical switch is preferred (and maybe necessary for the highest potential for bringing in radiant energy). In searching a switch of this type I could not find much online to help direct me, so can you suggest a possible component here?

For the Leben/Meissner circuit, what would be a likely choice for the transistor? (That is the only component that was not named, of all the parts listed).

I would have preferred to just dig in and try these two on my own, but since my electronics background is practically nil (with the exception of assembling a Xenon strobe light circuit from a kit many years ago) I was hoping you might take some pity on this poor physics-challenged soul and offer a couple of pointers. Any information you may provide in this regard will be most appreciated. Thank you, in advance.

Answer:

Thank you for your e-mail. Chapter 12 is supposed to give you enough electronics background to allow you to understand and build circuits of this kind. If it has not done that for you, then please give me a steer as to what more is needed and I will expand the chapter accordingly. (This is a genuine request on my part and is not meant to have any kind of negative connotations.)

The phrase electro-mechanical switch does not ring an immediate bell with me but the term implies that it is a mechanical switch which is activated electrically. That would include relays and the mechanical motor-driven switch shown as being what the Electrodyne Corp. staff used (it seems likely that Don Kelly was one of those Electrodyne Corp. people). Transistors were used in John Bedini's circuit replication which ran solidly for six months before it was smashed and he was intimidated into silence.

The reason why mechanical switching is sometimes recommended is because many people do not know how to get fast switching with semiconductors. The Tesla Switch circuit needs to have all the components working together and so even the diameter and length of the connecting wires can make a difference. It is a circuit where heavy loads will work better than tiny test loads as cold electricity operates the reverse of hot electricity and so the heavier the load, the better it works. It is one of the most difficult circuits to get working well, so you might be better off picking a different project.

I think that it is unlikely that the transistor in the Leben circuit is at all critical. Technically, it needs to be able to handle the current, and that will depend on the wire size you use and the number of turns (and to a lesser degree, on the frequency which is determined by the size of the capacitor). An MJ11016 is a powerful, high-gain transistor which should work well. A BD243C transistor is popular in circuits of this type although it has a much lower gain. Hope this helps, and good luck with your project(s).

Question:

Always been a fan of yours ever since I built my first "D18" cell which may I add is still going strong and saving me loads of money. I have a question regarding the Tesla Switch: you mention that the contacts on the discs attached to the motor are set at angles. Can you please explain in more detail.

Answer:

You are the first person I have ever come into direct contact with who has ever had any success with the "D18" Nitro Cell and I have had to classify it as a "doubtful" device because of that. If you are getting a benefit from it, then I would be delighted to change it's classification and combine with you to do a better presentation of the cell including your experiences with making and using it - if you have no objection to this, then please get back to me.

I'm sorry that you have found the switching disc details difficult to understand and I will upgrade the description in the next issue of the eBook. What I was trying to say is that each disc has one sixth of it's circumference clad in copper while the following sixth of the circumference is a non-conducting material.

As there are 360 degrees in a complete circle, one sixth of the circle covers an angle of 60 degrees, which is why 60 degrees is mentioned at the present time. I will expand the description to explain this in more detail. There is no question of the actual copper cladding (or whatever method of conducting contact that you choose to use) being itself angled in any way - it is just a case of there being three sections of the disc being conducting and having an equal sized non-conducting section on each side of the conducting sections. as the contact pairs are exactly opposite each other, this causes one pair of contacts to conduct while the pair directly opposite it is not conducting. Hope this helps and my apologies for the poor description in the eBook.

Question:

I was starting to get really interested in this Free Energy stuff, and before I found your website, I had contacted CAT (Centre for Alternative Technology, based in Wales). I presume that you have heard of them?

Anyways, I was hoping to get some information from them regarding the best renewable source of energy (I was thinking of using a small hydro scheme). I thought I'd also ask their advice on Hydroxy production. As I should have expected, they lambasted and patronised my comments so thoroughly I gave up any idea of hydroxy. If an organisation such as CAT finds hydroxy ridiculous, I couldn't believe that there was any future for Hydroxy on

demand.

Do you know of anyone that has managed to heat their home using hydroxy? and if so how? Would be interested to hear any ideas.

Answer:

The 'Chapter14.pdf' document shows ways to use hydroxy for heating - which is one of the most difficult things to use it for.

Your problem with 'CAT' is due to your not understanding the overall situation. Please don't for a moment take what I am about to say as being condescending or negative in any way as it most definitely is not intended to be.

There is a foreign State which is not answerable to anyone, based in London but it is not part of England or Britain. They have chosen the deliberately confusing name of "The Crown" (which has nothing to do with any Monarch) or the "Inner City of London". Their objective is to enslave and rob the British population without them ever realising what is happening. They are a consortium of bankers and lawyers and their biggest attack weapon is a society which they set up and own. It is called "The Law Society" and they use it to mount attacks on people who do not understand the situation.

They have set up a large number of commercial companies, each with a name intended to confuse and distract. One of their companies is called "The Ministry of Justice" and the name is intended to give the impression that it has ruling powers, when in fact, it is no different to a company such as Ladbrokes betting shop. Other companies which it owns include every Magistrates Court, every Police Constabulary, every Local Council, "The Bank of England", etc. etc.

They bolster their illusion by having a 'parliament' where their employees appear to argue with each other and people in general are fooled into thinking that those employees are working for them, and every so often, they even get to choose which employees are hired. The reality is that all important decisions are made in accordance with whatever the owners want and those decisions bear no relationship whatsoever to the facts or the benefit of the population as a whole.

Vast amounts of money are stolen on a continuous basis, using names such as "National Debt", "Foreign Aid", "Income Tax", "Council Tax", "Value Added Tax", "Fuel Levy", "TV Licence", etc. etc. etc.

They own agencies such as CAT and under no circumstances would they ever approve the use of any fuel which you do not have to buy from them, so HHO is OUT !! I suspect, although I have no direct evidence for it, that any subsidies offered for "green" projects are arranged to funnel money into the coffers of their friends and colleagues as that would be wholly consistent with everything else that they do. They will only ever support projects which will be ineffective and expensive. Dave Lawton has suffered at their hands when he made a grant application and was then visited by two CIA operatives (and yes, the CIA does operate freely in Britain with the full approval of the government which is owned by the foreign independent State "The Crown").

So, your asking them about HHO was roughly equivalent to asking them if they would mind if you were to stab them with a large knife - not exactly a popular enquiry. They repeatedly undertake false public relations exercises to convince the population that free-energy is 'impossible' and that using an HHO booster on an engine never gives any benefits at all - both of those statements being wholly false.

So, I would suggest that you stay away from CAT and similar companies as they are, in fact, the opposition and most definitely are not there to help you.

Question:

I have difficulty in understanding how electronic circuitry can be used to drive a Tesla Switch. Would you please show me how the components can be connected together.

Answer:

The Tesla Switch circuit used by the Electrodyne Corp. staff is shown here:

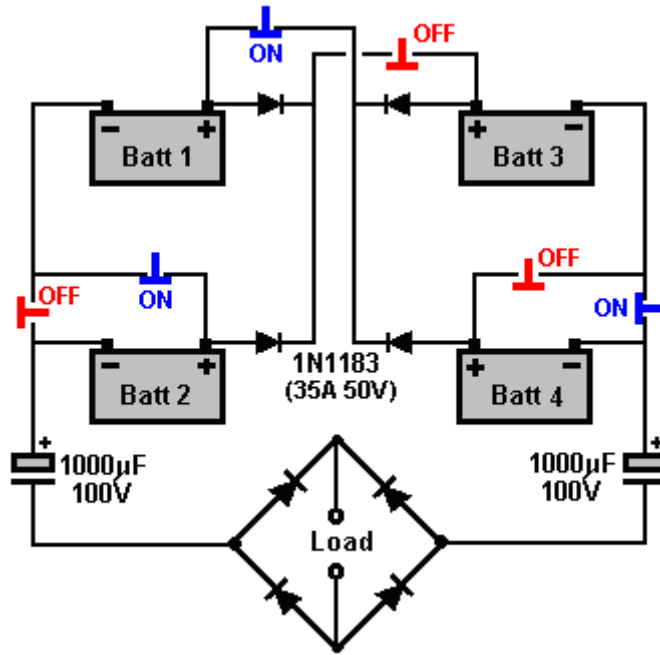

It is distinctly possible that the circuit does not reveal all the information needed for this system, as it may be necessary that the frequency at which the circuit runs needs to be a resonant harmonic of the batteries, or possibly, the load need to be a motor which generates voltage spikes. I do not know if that is the case, but I do know that the 1N1183 diodes are connected in reverse because they break down suddenly, passing a voltage spike to the batteries. It is distinctly possible that the batteries need to be conditioned for this circuit to perform the way that the Electrodyne Corp. staff reported. It should be remembered that they experimented with this and similar circuits for something like three years and it is highly likely that by the time they recorded their spectacular performances, the batteries had been very well conditioned due to the tests which they ran during those three years.

However, if I were to start experimenting with the circuit, I would show the two separate switching arrangements like this:

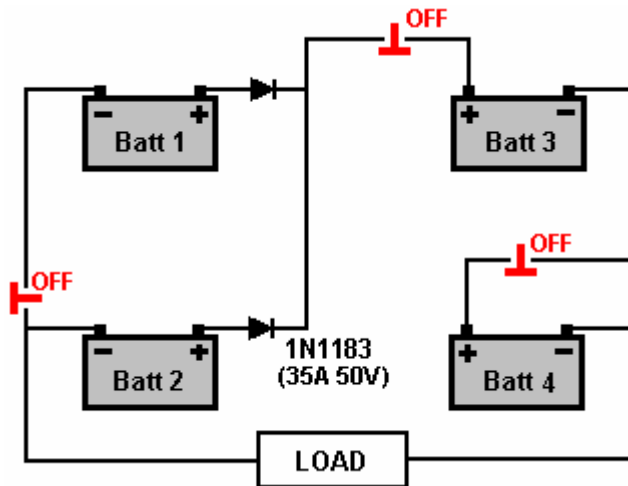

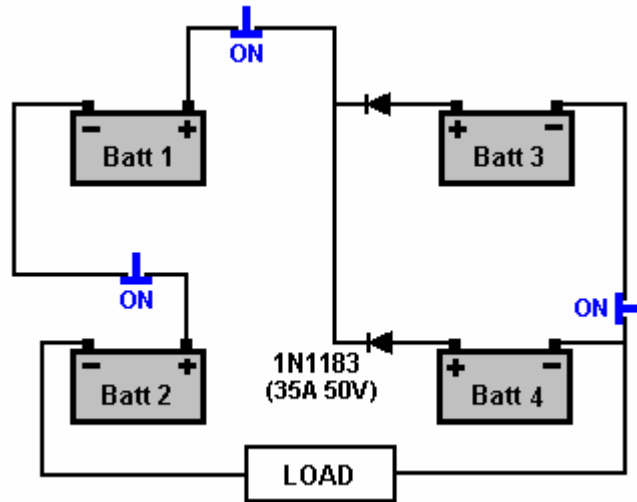

You will notice that each of these circuits are very direct and simple in themselves, but the “LOAD” is an essential part of the circuit and without it being in place (and able to carry current) neither circuit is completed. Personally, I would be inclined to use the 12V winding of a mains transformer as the load connection as that can handle both DC and AC current flow and the mains winding can have a bulb connected to it to show how the circuit is performing.

So, we are faced with two separate sets of three switches where each set needs to be closed when the other set is open. The question is, how can we use transistors to implement those switch operations? The difficulty is that there is no common negative voltage rail as the batteries keep getting swapped over as the circuit operates (which is the whole point of the circuit), and so, ideally, we want to switch each transistor with it connected permanently to just one battery. One circuit is:

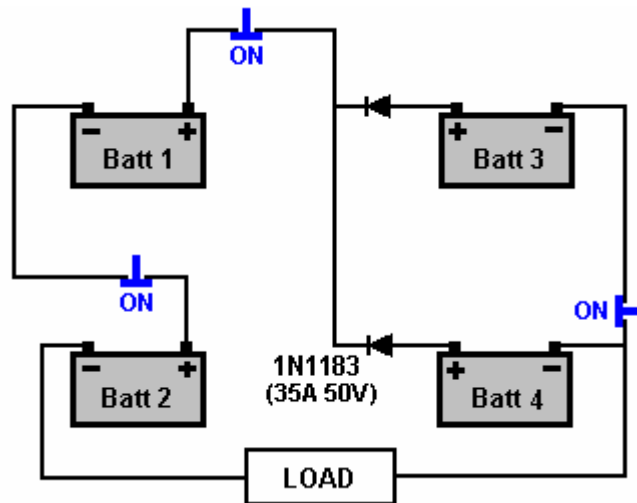

So if we were to use a transistor instead of one of the switches, we might make the circuit this:

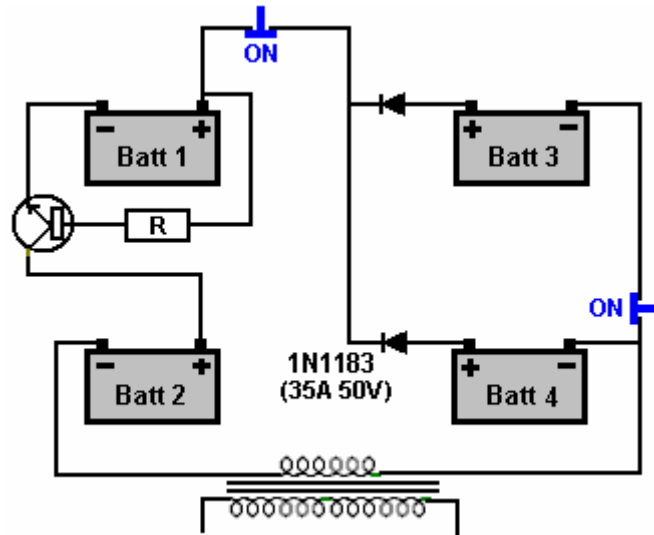

Here, the NPN transistor base is fed a current through resistor R, and as the transistor emitter is connected to the Battery 1 Minus and the resistor is connected to the Battery 1 Plus, there will always be a voltage difference able to feed current to the transistor base, switching it fully On. Obviously, we do not leave the resistor R connected to the Battery 1 Plus all the time, but will introduce some form of solid-state switching to switch the transistor on when we want it to be on and not at other times.

We can swap another of these switches with an NPN transistor like this:

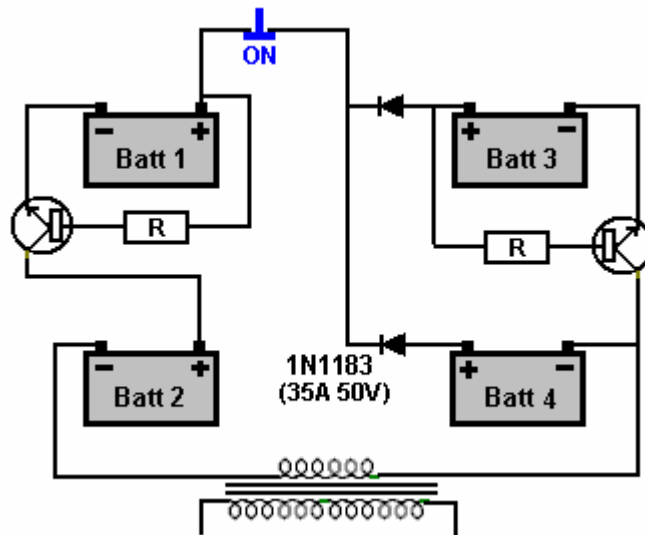

But we now get stuck because the remaining switch does not connect to the negative side of a battery. We can get around this by using a PNP transistor as it is the mirror image of an NPN type. The circuit could then be:

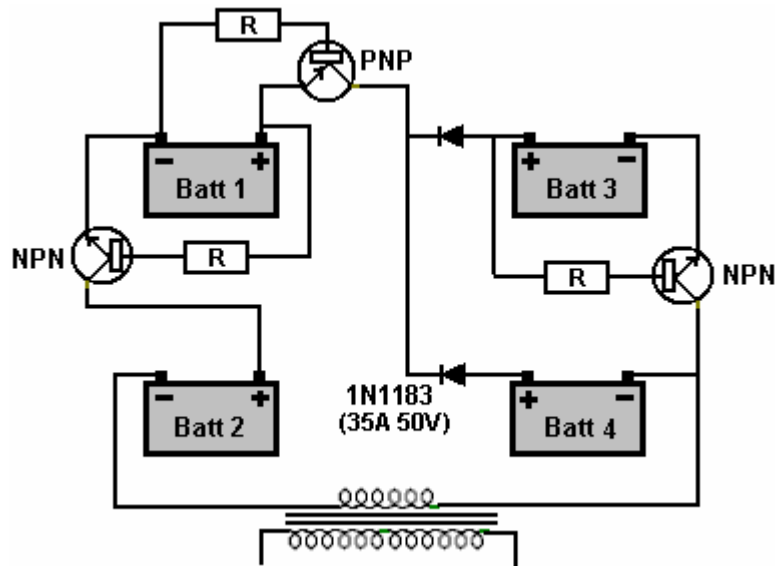

This circuit will have all three transistors switched On as heavily as possible at all times. But while that does appear to substitute transistors for mechanical switches, we want to be able to turn that set of three transistors On and Off when we want. That can be achieved by making the transistor base current flow through an Opto-Isolator which can be controlled by a completely separate circuit which is not connected to this Tesla Switch circuit in any way, perhaps like this:

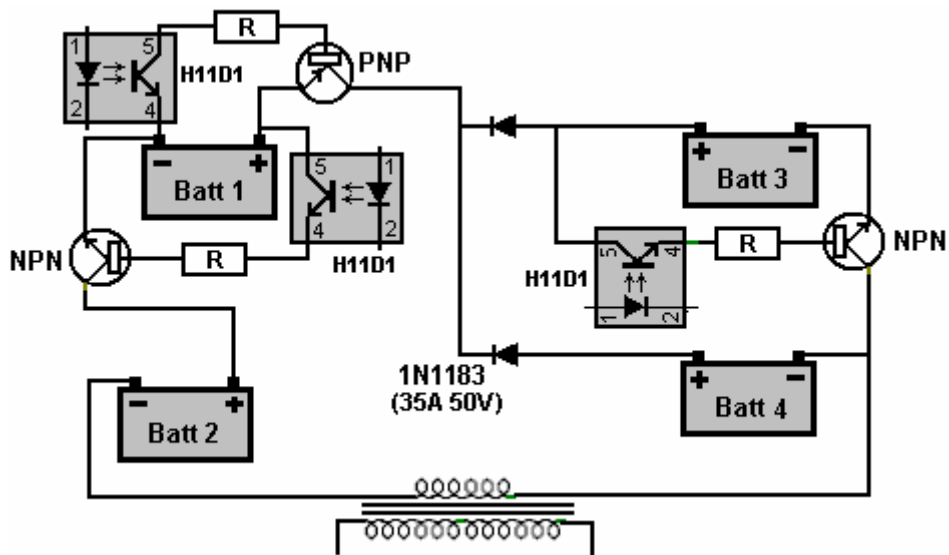

The opto-isolators shown here happen to be H11D1 types but many others could be used. Many different components could be used. The resistors 'R' could be, perhaps, 4.7 K, the PNP transistors MJ11015 and the NPNs MJ11016 or any high-gain, high-power transistors.

The three opto-isolators can be driven by a 555 timer signal generator which has a 50% Mark/Space ratio, perhaps like this:

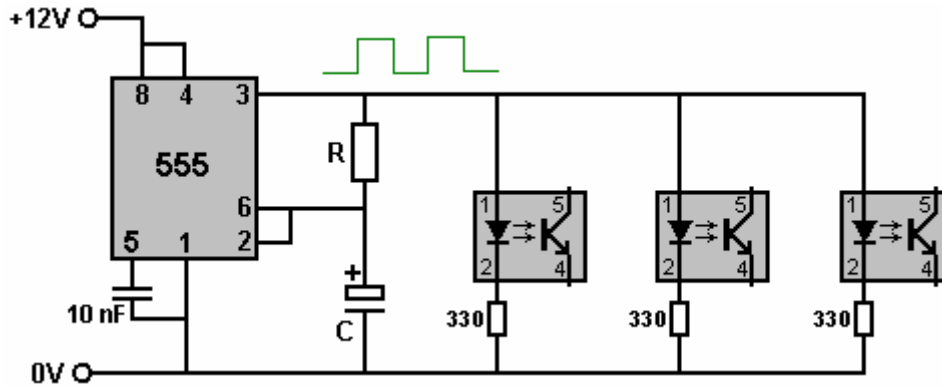

The 555 timing resistor 'R' can be replaced with a fixed resistor and a variable resistor in series, so that the frequency of the switching can be adjustable. A rate of 800 Hz might be suited to this circuit. Chapter 12 has a table of the R and C values for different frequencies (perhaps 100nF and a 4.7K plus a 100K variable in this case). The other three opto isolators can be driven via an inverter IC or via a PNP fed by pin 3 of the 555 timer IC. The transistor substitution for switches for the second part of the circuit can be done in the same way.

Question:

In chapter 14 you talk about the Frenette heater, under that article you make the suggestion that one could spin magnets next to an Al plate and make heat. I do not quite understand this, is there any way you could explain a little further, or make some drawing with suggestions?

Answer:

A simple magnetic heater is just a motor with a disc mounted on it's shaft. That rotor disc has magnets mounted on it and an aluminium plates is placed beside it as shown in the diagram below. As the magnet disc spins, it causes rapidly changing magnetic currents in the aluminium which causes it to heat up. If you use an ordinary fan to blow air across the aluminium plate, you get a hot-air heater system. Having sideways "fin" plates on the aluminium sheet should improve the heat transfer to the air.

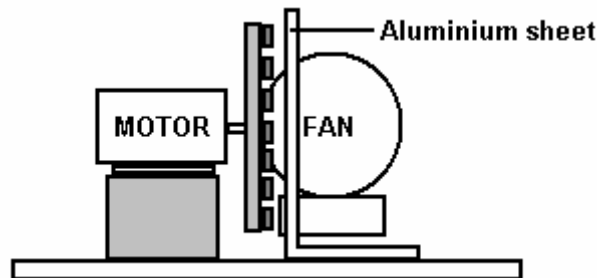

However, I have asked a man who has considerable experience in this area and he says:

Magnetic Heaters:

These are pictures of magnetic heaters which I have built and tested:





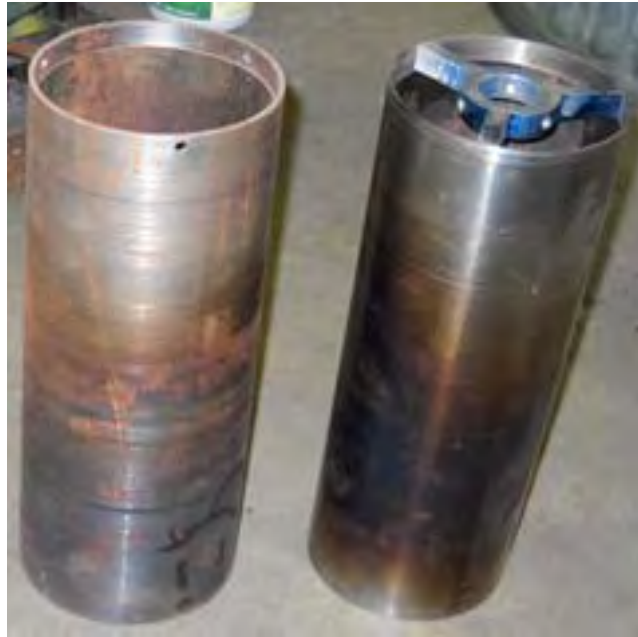

These pictures are of a magnetic heater driven by an induction motor. There are magnets placed between steel pole pieces which are adjustable to allow for the expansion caused by heating. The cylinders are made from A53 type steel. Cast iron is not suitable as the motor used spins at 3,600 rpm and cast iron has a different magnetic angle, which, while it causes a lot of resistance when being turned, slowly, does not heat up at the high speed used by me.

The steel cylinder needs to be electrically isolated from all of the other working parts of the heater and it needs to be allowed to float on the shaft so that it can increase in length as it heats up. The speed of rotation was 3,600 rpm and the cylinder was cut to a wall thickness of 0.108 inch (2.75 mm).

The colour distortion on the cylinders shown in the last photograph was caused by the heating of the cylinder when in use. These cylinders reached about 850°F and with the volume of air blown through the cylinder it produced air exhaust temperatures of 148°F. Importantly, this exiting air was ionized which provided benefits in addition to heating. Technically speaking, this ionization is actually an inefficiency.

When performing magnetic heating, the magnetic field needs to go through the metal and not along its surface as is the case in the heater shown above. Because of this, a different style of heater was built as shown here:

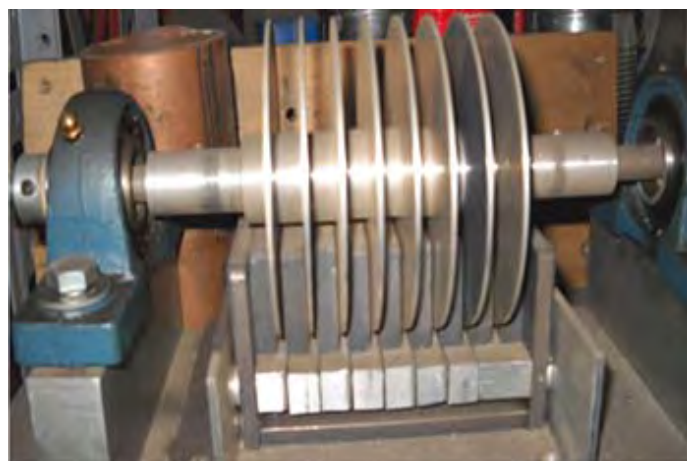

With this design, the magnets should not cover more than one quarter of the disc face and the magnetic field must pass all the way through each disc. Even with air being blown between the discs, the magnets get so hot that it becomes a long-term problem in that magnets lose their magnetism if raised to too high a temperature. The disc thickness is important.

There are some advantages of this type of heating mainly the motor type and power consumption allows for better than normal efficiency but that is not high enough for the construction cost to be recovered and that is why this

type of heater is not popular. However, it has the advantage that the ionization of the heated air can suppress virus and bacteria on surfaces.

It is important to note that a magnet moving over a plate heats only a small zone and the heated metal is only a narrow area within the magnetic field.

The magnetic cylinder heater shown was designed in 1989 by the late Frederick J. Galloway. Four videos have been made specifically for this query, showing the 4-kilowatt input power cylinder heater at:

<http://www.youtube.com/watch?v=JN1BXx-zXLA> Part 1 of 4

<http://www.youtube.com/watch?v=aS3SSeFbyds> Part 2 of 4

<http://www.youtube.com/watch?v=vhmQP0UStcA> Part 3 of 4

<http://www.youtube.com/watch?v=cV4Pg61wcp0> Part 4 of 4

Question:

What drawing package do you use to produce the diagrams in your eBook?

Answer:

I use the "Paint" program which comes free with Windows. As that answer upsets people, I have produced three casual videos explaining how easy it is to use. As I don't have a video camera or a phone with video facilities, these videos were produced using the FoxMagic program "Screen Virtuoso".

<http://www.youtube.com/watch?v=Q6inBL3f13E&context=C3f535afADOEgsToPDskl07u7HkyPbPJEIEQhd5qpV>

<http://www.youtube.com/watch?v=HUfXT5U-xGg&feature=context&context=C3f535afADOEgsToPDskl07u7HkyPbPJEIEQhd5qpV>

http://www.youtube.com/watch?v=PBA7LwTG_4&feature=context&context=C3f535afADOEgsToPDskl07u7HkyPbPJEIEQhd5qpV

Patrick Kelly

<http://www.free-energy-info.tuks.nl/>

Appendix

Wire Sizes:

The wire sizes specified for use in some designs are American Wire Gauge so a comparison table showing the UK Standard Wire Gauge (with lengths on a 500 gram reel of enamelled copper wire), and the American Wire Gauge is given here:

AWG	Dia mm	Area sq. mm	SWG	Dia mm	Area sq. mm	Max Amps	Ohms / metre	Metres Per 500g	Max Hz
1	7.35	42.40	2	7.01	38.60	119			325
2	6.54	33.60	3	6.40	32.18	94			410
3	5.88	27.15	4	5.89	27.27	75			500
4	5.19	21.20	6	4.88	18.68	60			650
5	4.62	16.80	7	4.47	15.70	47			810
6	4.11	13.30	8	4.06	12.97	37			1,100
7	3.67	10.60	9	3.66	10.51	30			1,300
8	3.26	8.35	10	3.25	8.30	24			1,650
9	2.91	6.62	11	2.95	6.82	19			2,050
10	2.59	5.27	12	2.64	5.48	15	0.0042		2,600
11	2.30	4.15	13	2.34	4.29	12	0.0053		3,200
12	2.05	3.31	14	2.03	3.24	9.3	0.0067	17.5 m	4,150
13	1.83	2.63	15	1.83	2.63	7.4	0.0085		5,300
14	1.63	2.08	16	1.63	2.08	5.9	0.0107	27 m	6,700
15	1.45	1.65	17	1.42	1.59	4.7	0.0135		8,250
16	1.29	1.31	18	1.219	1.17	3.7	0.0170	48 m	11 kHz
17	1.15	1.04				2.9	0.0214		13 kHz
18	1.024	0.823	19	1.016	0.811	2.3	0.027		17 kHz
19	0.912	0.653	20	0.914	0.657	1.8	0.034	85 m	21 kHz
20	0.812	0.519	21	0.813	0.519	1.5	0.043		27 kHz
21	0.723	0.412	22	0.711	0.397	1.2	0.054	140 m	33 kHz
22	0.644	0.325	23	0.610	0.292	0.92	0.069		42 kHz
23	0.573	0.259	24	0.559	0.245	0.729	0.086	225 m	53 kHz
24	0.511	0.205	25	0.508	0.203	0.577	0.109		68 kHz
25	0.455	0.163	26	0.457	0.164	0.457	0.137	340 m	85 kHz
26	0.405	0.128	27	0.417	0.136	0.361	0.174		107 kHz
27	0.361	0.102	28	0.376	0.111	0.288	0.218	500 m	130 kHz
28	0.321	0.0804	30	0.315	0.0779	0.226	0.276	700 m	170 kHz
29	0.286	0.0646	32	0.274	0.0591	0.182	0.344	950 m	210 kHz
30	0.255	0.0503	33	0.254	0.0506	0.142	0.439	1125 m	270 kHz
31	0.226	0.0401	34	0.234	0.0428	0.113	0.554	1300 m	340 kHz
32	0.203	0.0324	36	0.193	0.0293	0.091	0.685	1900 m	430 kHz
33	0.180	0.0255	37	0.173	0.0234	0.072	0.870	2450 m	540 kHz
34	0.160	0.0201	38	0.152	0.0182	0.056	1.105	3000 m	690 kHz
35	0.142	0.0159	39	0.132	0.0137	0.044	1.398	3700 m	870 kHz

PERMANENT MAGNET MOTOR

This patent application shows the details of a permanent magnet motor. It should be noted that while in this text, Frank states that permanent magnets store a finite amount of magnetism, in actual fact, the magnet poles form a dipole which causes a continuous flow of energy drawn from the quantum foam of our universe, and that flow continues until such time as the dipole is destroyed. The energy which powers any permanent magnet motor comes directly from the zero-point energy field and not actually from the magnet itself. A piece of iron can be converted into a magnet by a single nanosecond magnetic pulse. It makes no sense that a pulse of that duration could provide months of continuous power from anything stored in the magnet itself, but it makes perfect sense if that brief pulse created a magnetic dipole which acts as a gateway for the inflow of zero-point energy from the environment.

ABSTRACT

A motor providing unidirectional rotational motive power is provided. The motor has a generally circular stator with a stator axis, an outer surface, and a circumferential line of demarcation at about a midpoint of the outer surface. The motor also includes one or more stator magnets attached to the outer surface of the stator. The stator magnets are arranged in a generally circular arrangement about the stator axis and generate a first magnetic field. An armature is attached to the stator so that it rotates with it, the armature having an axis parallel to the stator axis. One or more rotors, are spaced from the armature and coupled to it by an axle to allow each rotor to rotate around an axis, each rotor rotating in a plane generally aligned with the axis of the armature. Each rotor includes one or more rotor magnets, with each rotor magnet generating a second magnetic field. The second magnetic field generated by each rotor magnet interacts with the first magnetic field, to cause each rotor to rotate about the rotor axis. A linkage assembly drive connects each rotor to the stator to cause the armature to rotate about the armature axis thereby providing the unidirectional rotational motive power of the motor.

BACKGROUND OF THE INVENTION

This invention relates to dynamo electric motor structures and more particularly to rotary and linear permanent magnet motors. Conventional electric motors rely on the interaction of magnetic fields to produce a force which results in either rotary or linear motion. The magnetic fields in conventional electric motors providing rotary power, are generated by passing an externally provided electric current through conductors in either a stator (i.e. stationary portion of the motor), a rotor (i.e. rotary portion) or both the stator and the rotor. The rotary power of the motor arises from a rotating magnetic field which is created by commutating the electric current, either by a switching the current through different conductors, as in a direct current motor or by a polarity reversal of the electric current as in an alternating current motor.

It is well known that a class of materials known as ferromagnetic materials are also capable of generating a magnetic field having once been energised. Ferromagnetic materials with high coercivity are known as permanent magnets. Permanent magnets are capable of storing a finite amount of energy and retaining the ability to generate a substantial magnetic field until the stored energy is depleted.

There are electric motors which use permanent magnets in either the stator portion of the motor or the rotor portion of the motor. These motors achieve a small size for the amount of power delivered by the motor because the motors avoid having current carrying conductors to produce the magnetic field which is otherwise produced by the permanent magnets. However, these conventional permanent magnet motors still require a source of external power to produce a rotating magnetic field.

There have also been developed permanent magnet motors which use permanent magnets for both the stator and the rotor. For example, U.S. Pat. No. 4,598,221 discloses a permanent magnet motor which relies on an external source of power to rotate the magnetic fields of a rotor by ninety degrees with respect to the interacting stator magnetic fields to eliminate the counterproductive magnetic repulsion and attraction between the rotor and the stator magnets. In another example, U.S. Pat. No. 4,882,509 discloses a permanent magnet motor which relies on an external source of power to position a shield which does not permit coupling between the rotor and the stator magnets at times when attraction or repulsion would drag down the strength of the motor.

There are many instances where a motor action is required and no source of external power is available. Accordingly, a motor which relies solely on the energy stored in permanent magnets would be useful.

BRIEF SUMMARY OF THE INVENTION

Briefly stated, the present invention comprises a rotor for use in a permanent magnet motor and for providing motive power by rotation of the rotor about a rotor axis. The rotor comprises at least one first U-shaped magnet having a rear side and generating a first magnetic field. The rotation of the rotor about the rotor axis is caused by an interaction of a portion of the first magnetic field directly adjacent to the rear of the at least one U-shaped magnet with a stationary second magnetic field.

Another aspect of the present invention comprises a rotor providing motive power by a rotation of the rotor about the rotor axis and by a translation of the rotor in a direction of the rotor axis. The rotor comprises: a first U-shaped magnet having a north pole, a south pole and a rear side, the first U-shaped magnet generating a first magnetic field; a second U-shaped magnet having a north pole and a south pole, the south pole of the second U-shaped magnet abutting the north pole of the first U-shaped magnet; and a third U-shaped magnet having a north pole and a south pole, the north pole of the third U-shaped magnet abutting the south pole of the first U-shaped magnet. A portion of the first magnetic field generated by the first U-shaped magnet directly adjacent to the rear of the first U-shaped magnet interacts with a stationary fourth magnetic field to cause the rotor to rotate. A second magnetic field generated by the north pole of the second U-shaped magnet and a third magnetic field generated by the south pole of the third U-shaped magnet interact with the fourth magnetic field to cause the rotor to translate in the direction of the rotor axis.

A further aspect of the present invention comprises a rotor including a rotor axis, and a thruster axis in a plane of the rotor and intersecting the rotor axis. The rotor provides motive power by a rotation of the rotor about the rotor axis and by a translation of the rotor in a direction of the rotor axis. The rotor comprises: a first U-shaped magnet having a north pole and a south pole and a rear side, the north pole and the south pole being generally aligned with the thruster axis, the first U-shaped magnet generating a first magnetic field; a first thruster magnet having a direction of magnetisation generally aligned with the thruster magnet axis, the first thruster magnet being proximate to and spaced from the north pole of the first U-shaped magnet; and a second thruster magnet having a direction of magnetisation generally aligned with the thruster magnet axis, the second thruster magnet being near to and spaced from the south pole of the first U-shaped magnet, the first U-shaped magnet being interposed between the first and the second thruster magnets. A portion of the first magnetic field generated by the first U-shaped magnet directly adjacent to the rear side of the first U-shaped magnet interacts with a stationary fourth magnetic field to cause the rotor to rotate, a second magnetic field generated by the first thruster magnet and a third magnetic field generated by the second thruster magnet respectively interact with a stationary fifth magnetic field to cause the rotor to translate in the direction of the rotor axis.

Another aspect of the present invention comprises a rotor providing motive power by rotation of the rotor about a rotor axis and translation of the rotor in the direction of the rotor axis. The rotor has at least one rotor magnet generating a first magnetic field, the first magnetic field being generated by the rotor magnet interacting with at least one stationary U-shaped magnet, the U-shaped magnet having a rear side and generating a second magnetic field. The rotational and translational motive power of the rotor is provided by an interaction of a portion of the second magnetic field directly adjacent to the rear of the U-shaped magnet with the first magnetic field.

A further aspect of the present invention comprises a motor providing unidirectional rotational motive power. The motor includes a generally circular stator having a stator axis, an outer surface, and a circumferential line of demarcation at about a midpoint of the outer surface; at least one stator magnet attached to the outer surface of the stator, the at least one stator magnet being arranged in a generally circular arrangement about the stator axis and generating a first magnetic field; an armature attached to the stator for rotation with it; the armature having an axis parallel to the stator axis; at least one rotor, the rotor being spaced from the armature and coupled to it by an axle to allow rotation about an axis of the rotor, the rotor rotating in a plane generally aligned with the armature axis, the rotor, including at least one magnet generating a second magnetic field, where the second magnetic field generated by the rotor magnet interacts with the first magnetic field to cause the rotor to rotate about its axis; and a drive linkage assembly connecting the rotor to the stator to cause the armature to rotate about its axis as the rotor rotates about its axis, thereby providing the unidirectional rotational motive power of the motor.

In another aspect, the present invention is directed to a motor providing unidirectional rotational motive power comprising: a generally circular stator having an axis, an outer surface, and a circumferential line of demarcation around the outer surface, the line of demarcation having a pre-determined direction around the stator axis and separating a first side of the outer surface and a second side of the outer surface, wherein at least one pair of stator magnets is attached to the outer surface generating a first magnetic field, the pair of magnets comprising a first stator magnet having a north pole and a south pole and a second stator magnet having a north pole and a south pole, the south pole of the first stator magnet being located on the first side of the outer surface and the north pole of the first stator magnet being closest to the line of demarcation, the north pole of the second stator magnet being located on the second side of the outer surface and the south pole of the second stator magnet being closest to the line of demarcation, wherein the at least one pair of stator magnets is spaced along the line of demarcation so that a first inter-magnet distance measured along the line of demarcation between the north pole of the first stator magnet and the south pole of the second stator magnet of an adjacent pair of the at least one pair of stator magnets is generally equal to a second inter-magnet distance measured along the line of

demarcation between the south pole of the first stator magnet and the north pole of the second stator magnet; an armature attached to the stator, the armature having an axis parallel to the stator axis and attached to the stator for rotation therewith; and at least one rotor attached to the armature, the at least one rotor being spaced from the armature and coupled to it by an axle for rotation about an axis of the rotor, the rotor rotating in a plane generally aligned with the armature axis, the rotor comprising at least one rotor magnet, the rotor magnet generating a second magnetic field which interacts with the first magnetic field to cause the rotor to rotationally oscillate about the axis of the rotor and to generate a force in a direction of the rotor axis, thereby causing the armature to rotate in the pre-determined direction around the armature axis to provide the unidirectional rotational motive power of the motor.

In a further aspect, the present invention is directed to a motor providing unidirectional linear motive power comprising: a linear stator having a generally curved cross-section and a longitudinal line of demarcation perpendicular to the cross-section extending on about a midpoint of a surface of the stator between a first end and a second end of the stator, the stator including at least one magnet arranged between the first end and the second end, the magnet having a direction of magnetisation at about a right angle to the line of demarcation and generating a first magnetic field, the magnitude of the first magnetic field being generally uniform along the line of demarcation except in a pre-determined number of null regions, wherein the first magnetic field is substantially zero a rail connected to the stator, the rail having a longitudinal axis generally parallel to the line of demarcation and a helical groove with a pre-determined pitch running around a periphery of the rail; at least one rotor having a rotor axis aligned with the axis of the rail, the rotor being connected to the rail so that the rotor is free to rotate about the axis of the rail and slide along the rail, the rotor including at least one U-shaped magnet having a rear side and generating a second magnetic field, where a portion of the second magnetic field directly adjacent to the rear of the U-shaped magnet interacts with the first magnetic field to cause the rotor to rotate about the axis of the rail; a bearing assembly connecting the rotor to the helical groove, the bearing assembly converting the rotary motion of the rotor about the axis of the rail to linear motion along the rail; and a cross-link connecting the bearing assembly of a first rotor to a second rotor, thereby adding together the linear motion along the rail of the first rotor and the second rotor to provide the unidirectional linear motive power.

In yet another aspect, the present invention is directed to a motor providing unidirectional motive power comprising: a rail having a longitudinal axis and at least one helical groove having a pre-determined pitch running around a periphery of the rail; at least one first helical stator concentrically surrounding the rail, the first helical stator having the pre-determined pitch of the groove and a longitudinal axis generally parallel to the axis of the rail, at least one first stator magnet being attached to the first helical stator, the first stator magnet generating a first magnetic field; at least one rotor having an axis generally aligned with the axis of the rail, the rotor being connected to the rail so that the rotor is free to rotate about the axis of the rail and slide along the rail, the rotor comprising at least one rotor magnet generating a second magnetic field, the second magnetic field interacting with the first magnetic field generated by the first stator magnet to cause the rotor to rotate about the axis of the rail; and a bearing assembly connecting the rotor to the helical groove around the periphery of the rail, the bearing assembly converting the rotational motion of the rotor about the rail to unidirectional linear motion along the rail.

A further aspect of the present invention is directed to a motor providing unidirectional motive force comprising: a rail having a longitudinal axis and a helical groove running around the rail, the groove having a predetermined pitch; at least one first helical stator comprising a plurality of discontinuous spaced apart first ribs, each first rib partially surrounding the rail at a generally uniform distance from the rail, the first helical stator having the pre-determined pitch of the groove and a longitudinal axis generally aligned with the rail, at least one first stator magnet being attached to each rib, each first stator magnet generating a first magnetic field; at least one rotor having an axis generally aligned with the axis of the rail, the rotor being connected to the rail so that the rotor is free to rotate about the axis of the rail and to slide along the rail, the rotor comprising at least one rotor magnet generating a second magnetic field, the second magnetic field interacting with the first magnetic field generated by the first stator magnet to cause the rotor to rotate about the axis of the rail; and a bearing assembly connecting the rotor to the helical groove around the rail, the bearing assembly converting the rotary motion of the rotor about the rail to linear motion along the rail.

The present invention is further directed to a motor providing unidirectional motive power comprising: a rail having a longitudinal axis and a generally sinusoidal groove running around a periphery of the rail, the sinusoidal groove having a pre-determined period; at least one stator having a generally curved cross-section and a longitudinal line of demarcation perpendicular to the cross-section located at about a midpoint of a surface of the stator, the surface of the stator being disposed generally equidistant from and parallel to the axis of the rail; at least one stator magnet attached to the surface of the stator generating a first magnetic field, the stator magnet having a magnetisation which is displaced sinusoidally from the line of demarcation, the sinusoid having a pre-determined period and a pre-determined maximum amplitude and being divided into a plurality of alternating first and second sectors, with a boundary between the alternating first and second sectors occurring at the maximum amplitude of the sinusoid, the direction of magnetisation of the stator magnet being opposite in direction in the first and second segments; at least one rotor having an axis aligned with the axis of the rail, the rotor being connected to the rail so that the rotor is free to rotate about the axis of the rail and slide along the rail, the rotor including at least one U-

shaped magnet having a rear side and generating a second magnetic field, the U-shaped magnet being positioned on the rotor so that the rear side of the U-shaped magnet is apposite to the first and the second segments of the stator as the rotor rotates about the rotor axis, wherein an interaction of a portion of the second magnetic field directly adjacent to the rear of the U-shaped magnet with the first magnetic field causes the rotor to rotationally oscillate about the axis of the rail; and a bearing assembly connecting the rotor to the sinusoidal groove around the rail, the bearing assembly converting the oscillatory motion of the rotor about the rail to unidirectional linear motion along the rail.

The present invention is also directed to a motor providing unidirectional motive power comprising: a rail having a longitudinal axis and a helical groove running around a periphery of the rail, the helical groove having a pre-determined pitch; at least one stator having a generally having a longitudinal line of demarcation located at about a midpoint of a surface of the stator, the surface of the stator being disposed generally equidistant from and parallel to the axis of the rail; at least one stator magnet attached to the surface of the stator, the stator magnet having a direction of magnetisation which rotates about a magnetic axis parallel to the line of demarcation with a predetermined pitch, thereby generating a first magnetic field having a substantially uniform magnitude along the magnetic axis and rotates around the magnetic axis with the pre-determined pitch of the stator magnet rotation; at least one rotor having an axis aligned with the axis of the rail, the rotor being connected to the rail so that the rotor is free to rotate about the axis of the rail and slide along the rail, the rotor including at least one U-shaped magnet generating a second magnetic field, the U-shaped magnet being positioned on the rotor so that a portion of the second magnetic field directly adjacent to the rear side of the U-shaped magnet interacts with the first magnetic field of the stator magnet to cause the rotor to rotate about it's axis; and a bearing assembly connecting the rotor to the helical groove, the bearing assembly converting the rotary motion of the rotor about the rail to unidirectional linear motion along the rail.

BRIEF DESCRIPTION OF THE SEVERAL VIEWS OF THE DRAWINGS

The foregoing summary, as well as the following detailed description of preferred embodiments of the invention, will be better understood when read in conjunction with the appended drawings. For the purpose of illustrating the invention, there are shown in the drawings embodiments which are presently preferred. It should be understood, however, that the invention is not limited to the precise arrangements and instrumentalities shown. In the drawings:

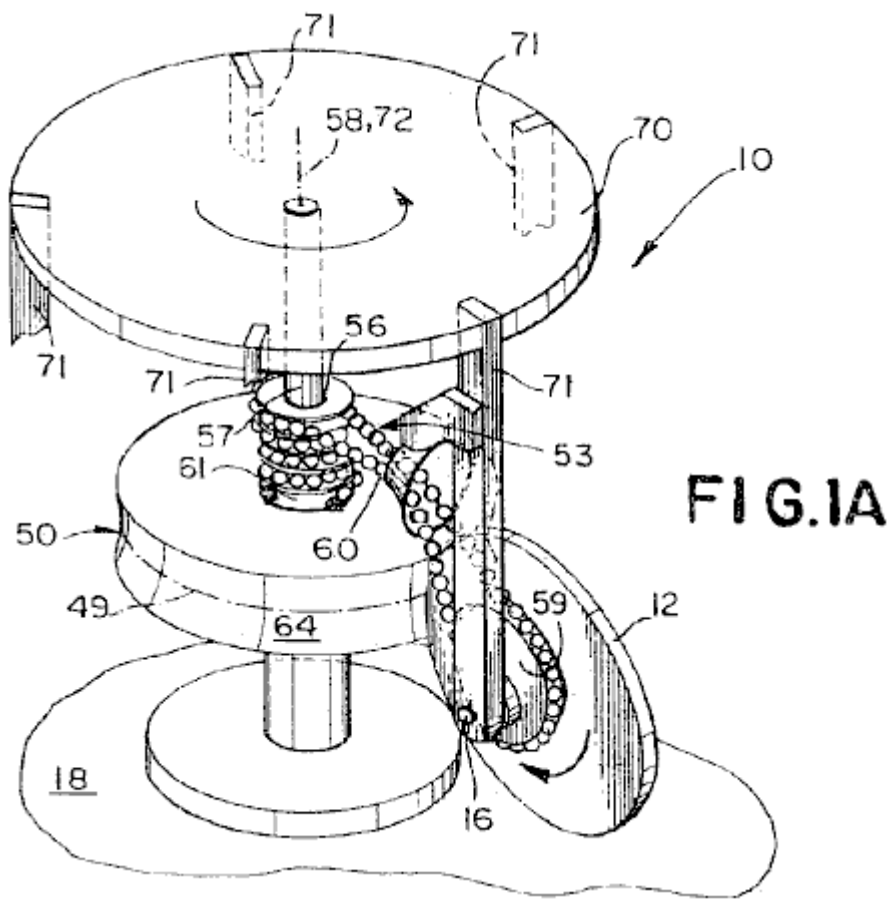

Fig.1A is a schematic perspective drawing of a first preferred embodiment of a motor providing unidirectional motive power;

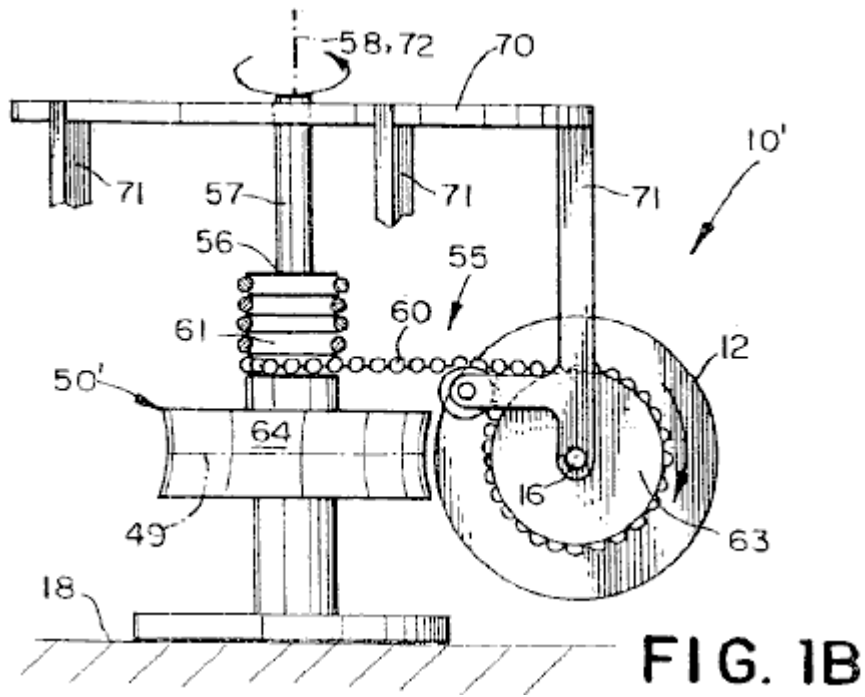

Fig.1B is a schematic perspective drawing of a second preferred embodiment of the motor;

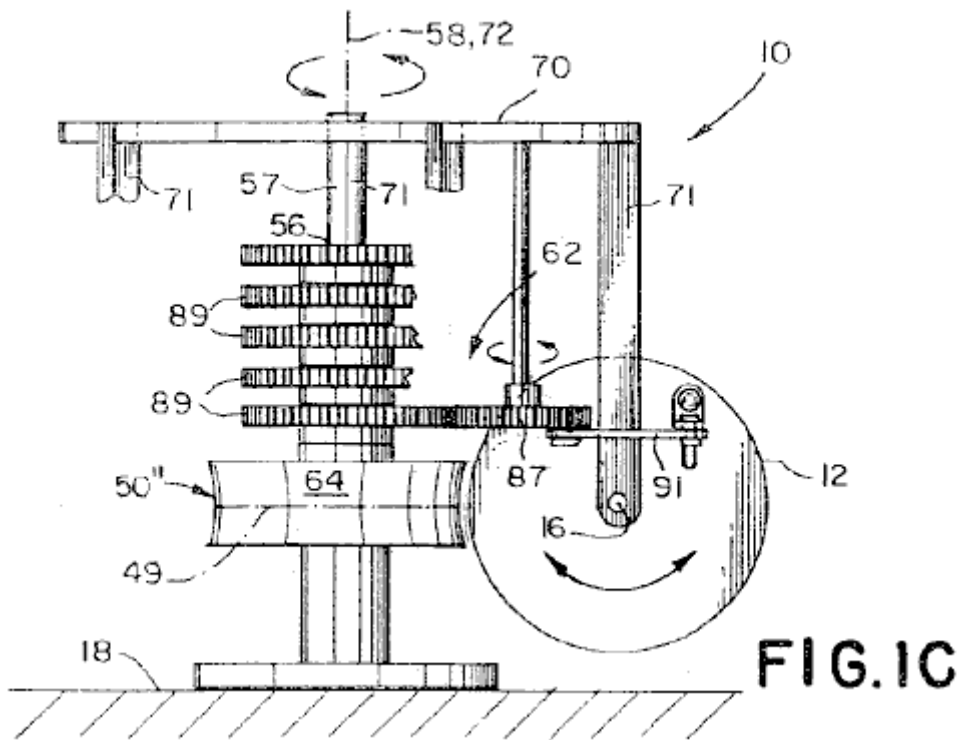

Fig.1C is a schematic perspective drawing of a third preferred embodiment of the motor;

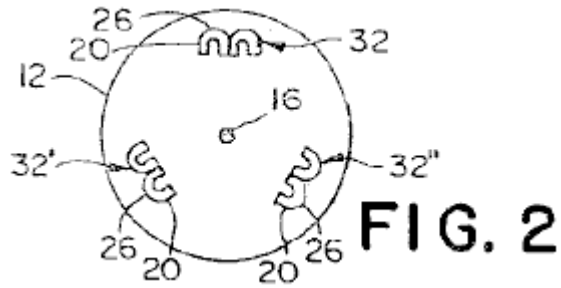

Fig.2 is a schematic plan view of a rotor comprising three pair of U-shaped magnets;

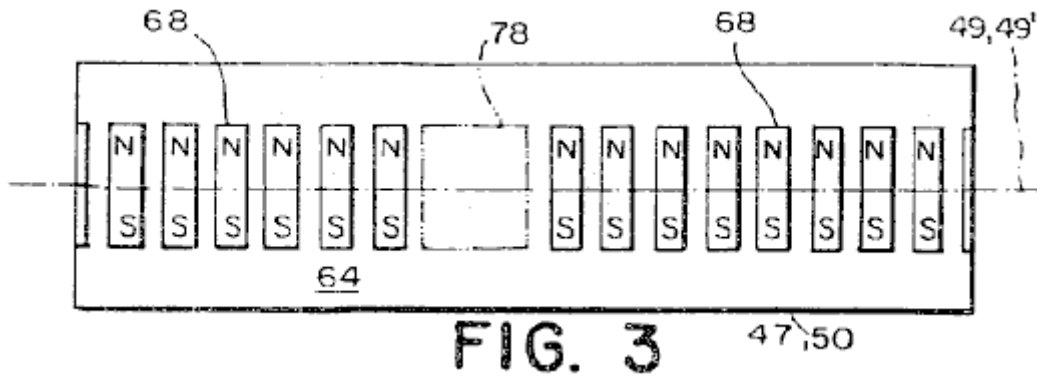

Fig.3 is a schematic plan view of stator having a plurality of stator magnets generating a uniform magnetic field except in single null region, laid out flat for ease of illustration;

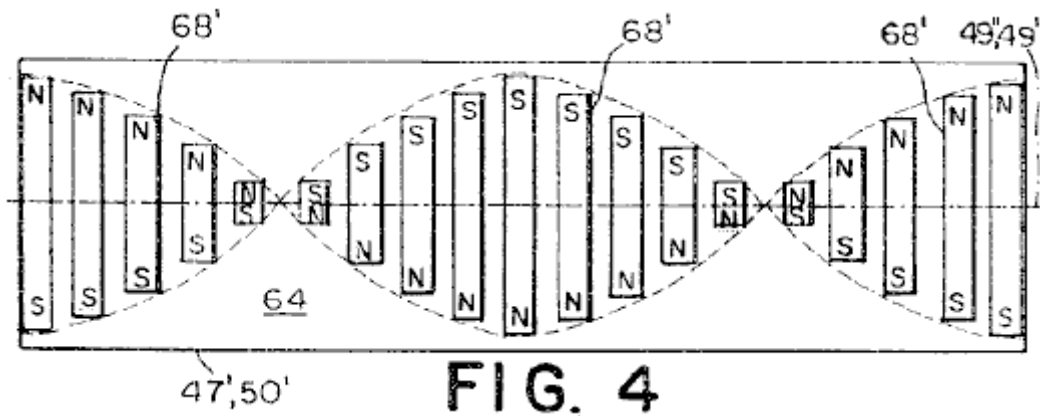

Fig.4 is an schematic plan view of a stator having a plurality of stator magnets which rotate about a magnetic axis, laid out flat for ease of illustration;

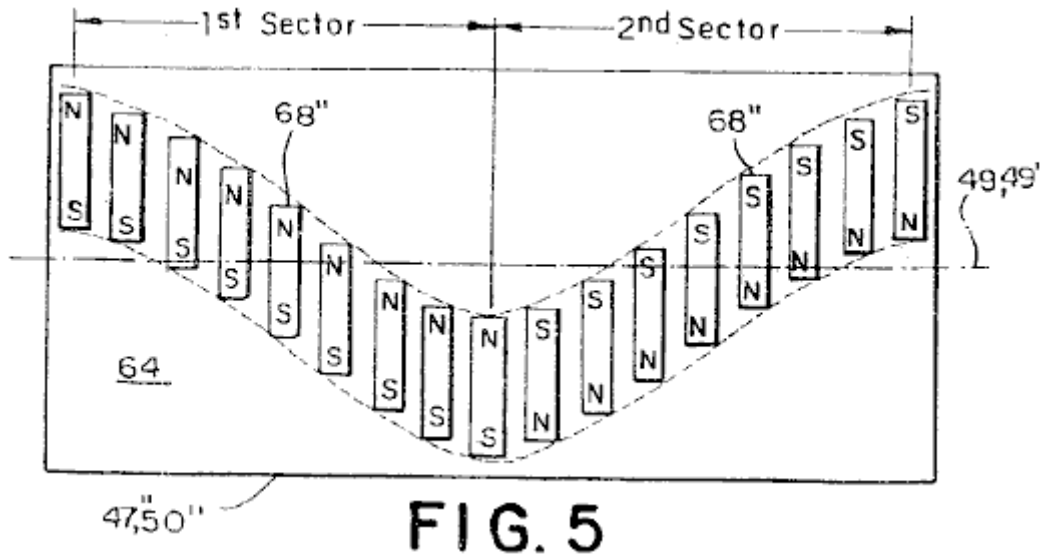

FIG. 5

Fig.5 is an schematic plan view of a stator having a plurality of stator magnets which are sinusoidally displaced from a line of demarcation, laid out flat for ease of illustration;

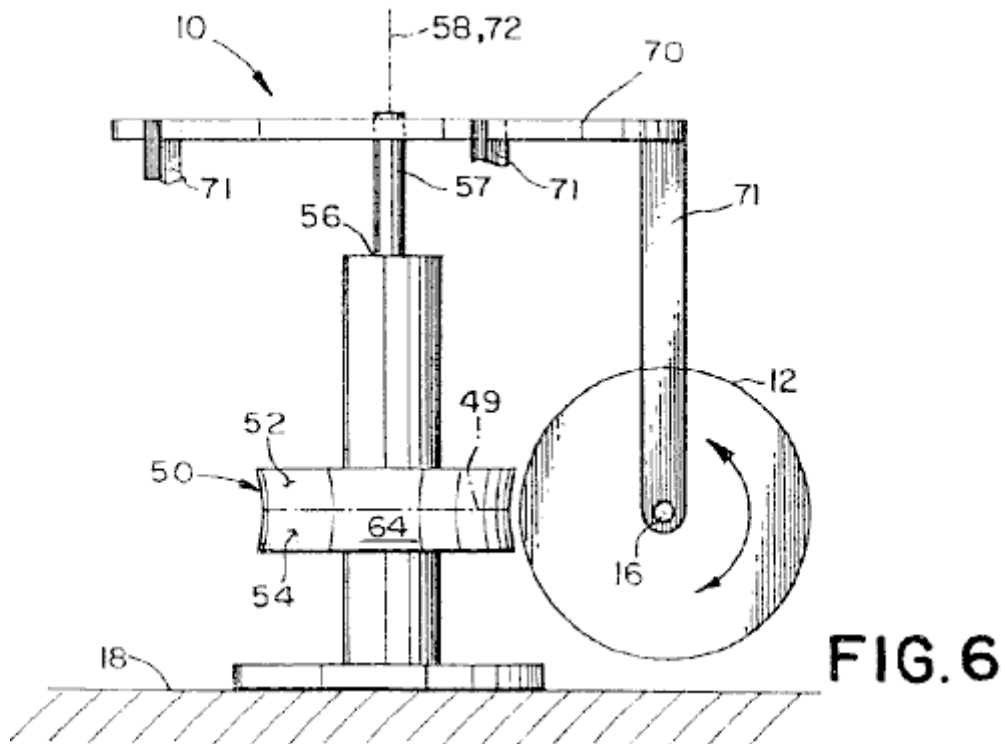

FIG. 6

Fig.6 is a schematic perspective view of a fourth through a seventh preferred embodiment of the motor;

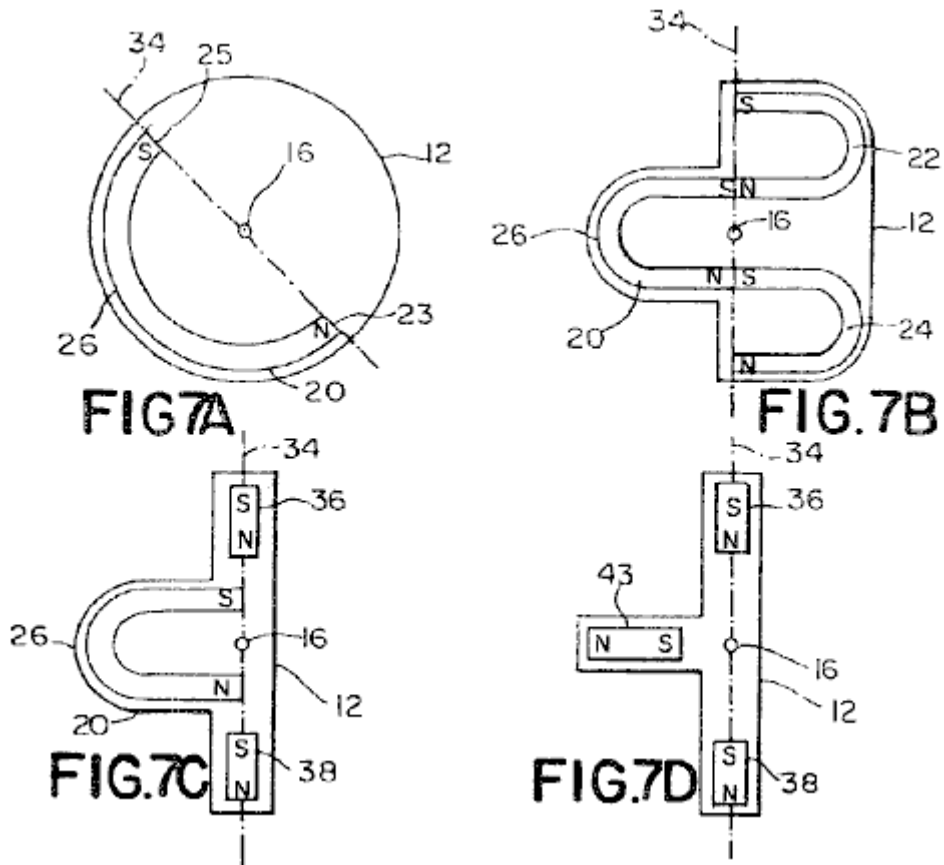

Fig.7A is a schematic plan view of a rotor used in the fourth preferred embodiment and in an eighth preferred embodiment of the motor;

Fig.7B is a schematic plan view of a rotor used in a fifth preferred embodiment and in a ninth preferred embodiment of the motor;

Fig.7C is a schematic plan view of a rotor used in a sixth preferred embodiment and in a tenth preferred embodiment of the motor;

Fig.7D is a schematic plan view of a rotor used in the seventh preferred embodiment and in an eleventh preferred embodiment of the motor;

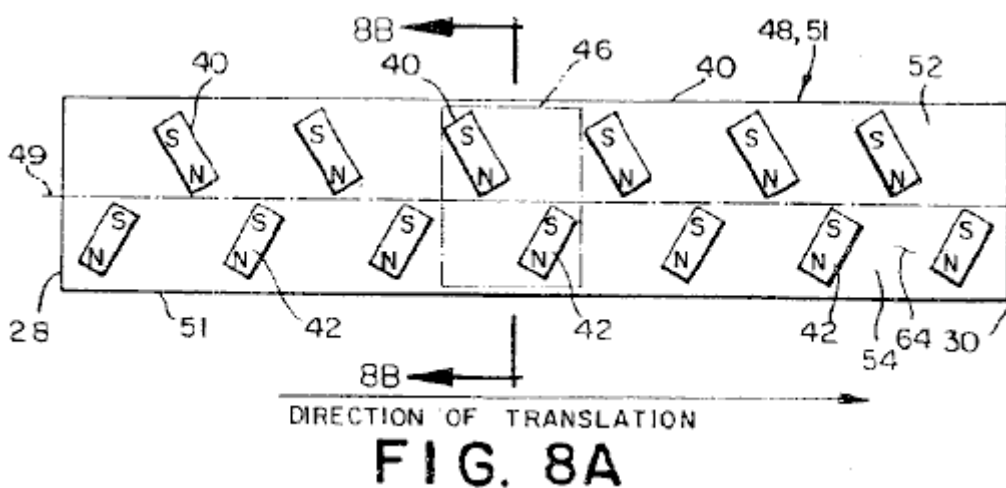

Fig.8A is a schematic plan view of a stator used in the fourth, fifth, eighth and ninth preferred embodiments of the motor;

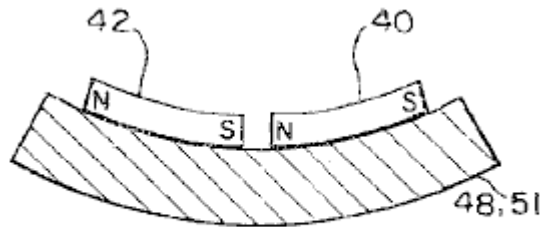

FIG. 8B

Fig.8B is a schematic sectional view of the stator shown in Fig.8A taken along the line 8B-8B;

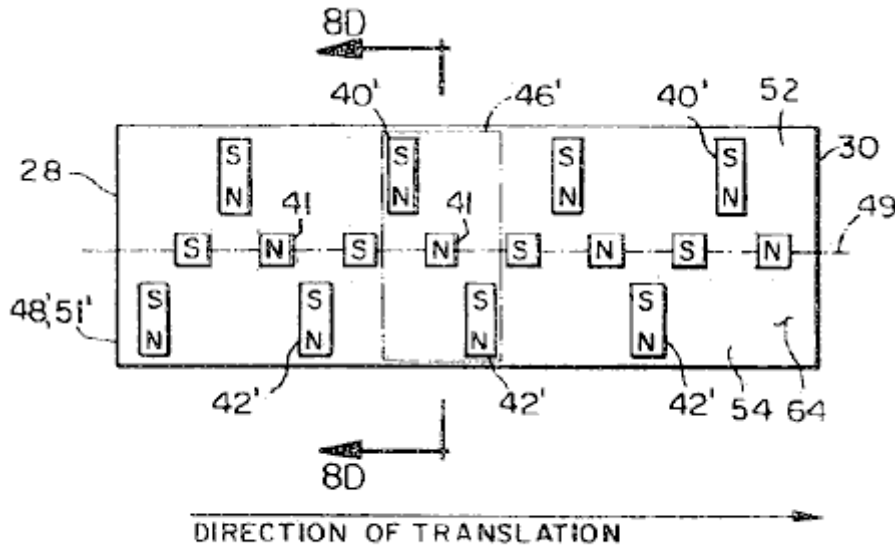

FIG. 8C

Fig.8C is a schematic plan view of a stator used in the sixth and in the tenth preferred embodiments of the motor;

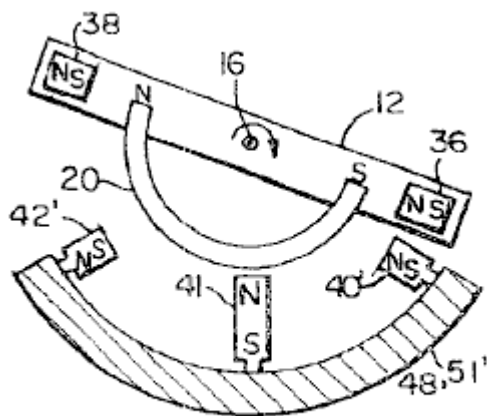

FIG. 8D

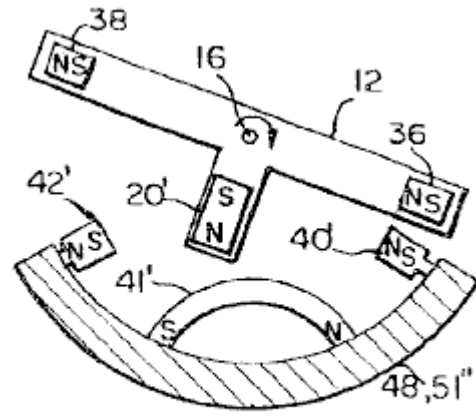

FIG. 8E

Fig.8D is a schematic elevational view of the stator shown in Fig.8C taken along the line 8D-8D shown with the rotor shown in Fig.7C;

Fig.8E is a schematic elevational view of an alternative stator shown with the rotor shown in Fig.7D;

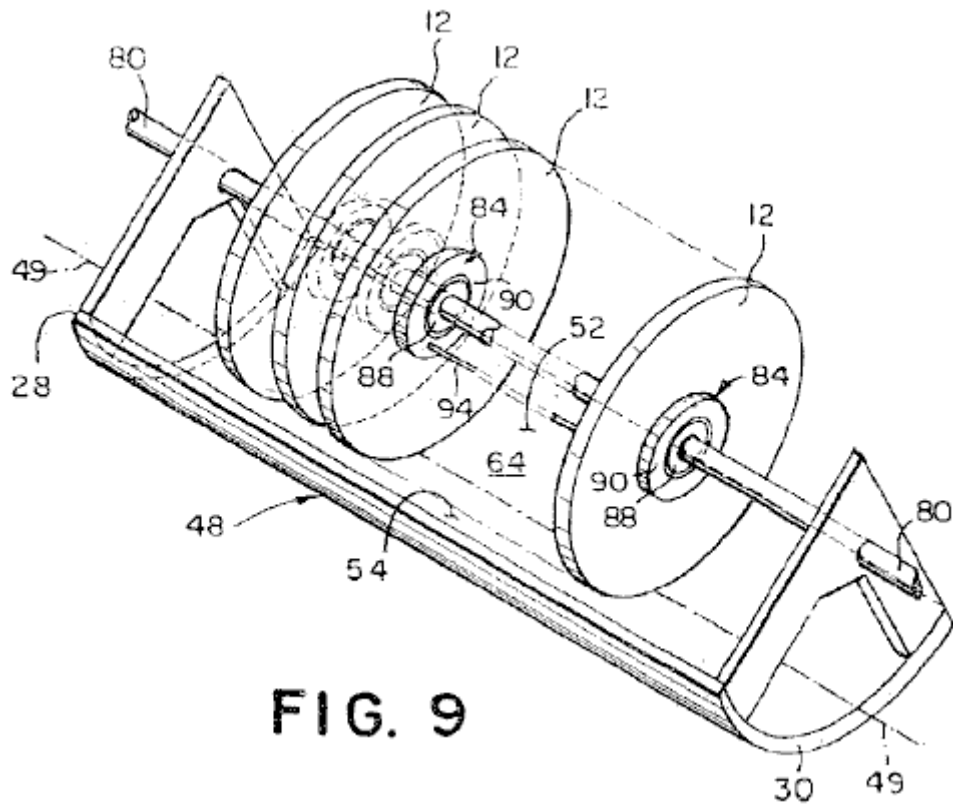

FIG. 9

Fig.9 is a schematic perspective view of the eighth through an eleventh preferred embodiment of the motor;

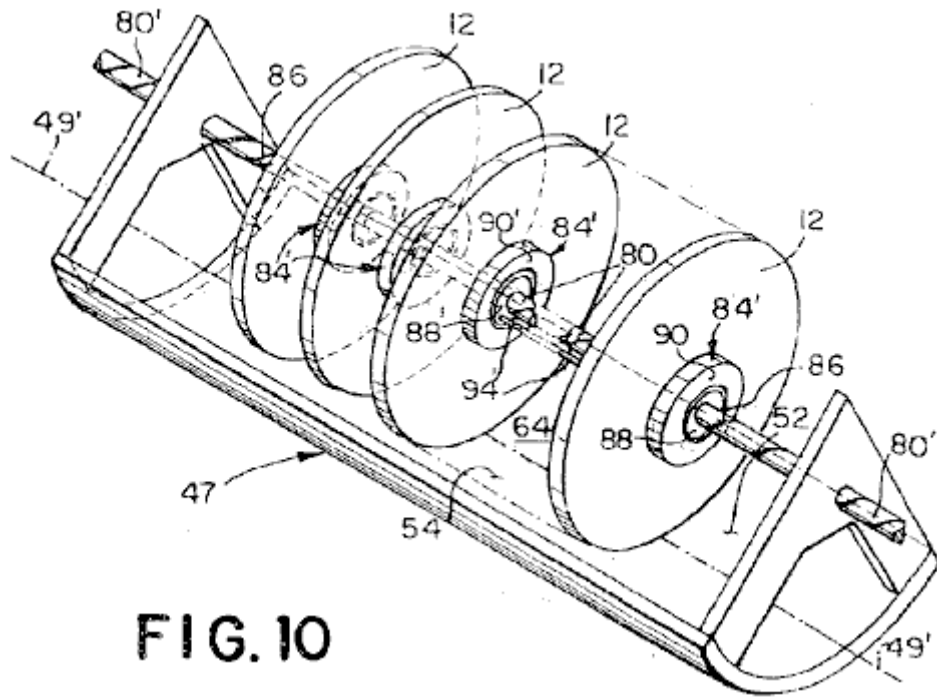

FIG. 10

Fig.10 is a schematic perspective view of a twelfth preferred embodiment of the motor;

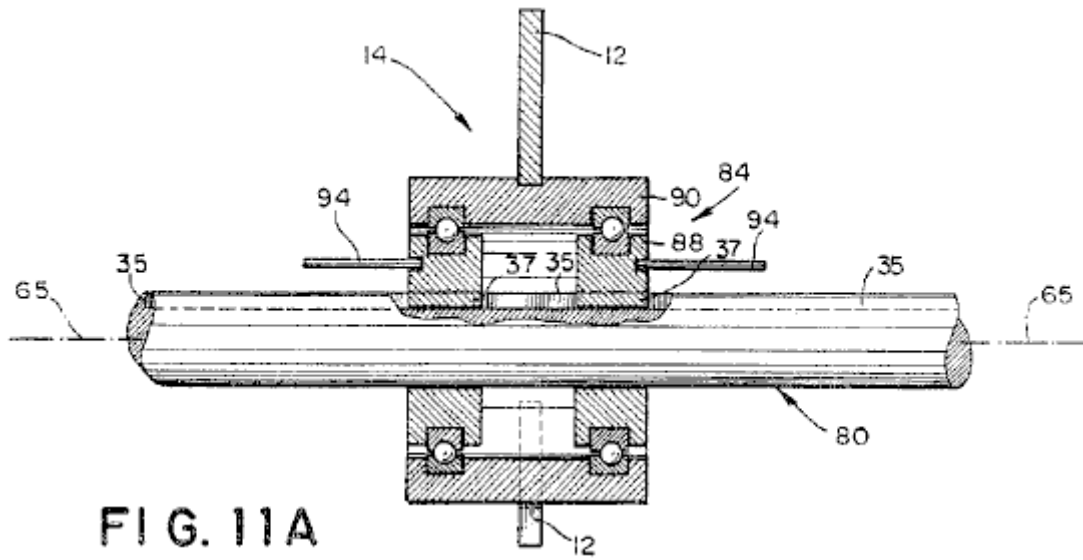

FIG. 11A

Fig.11A is a plan view of a rotor assembly used in the eighth through the eleventh preferred embodiments;

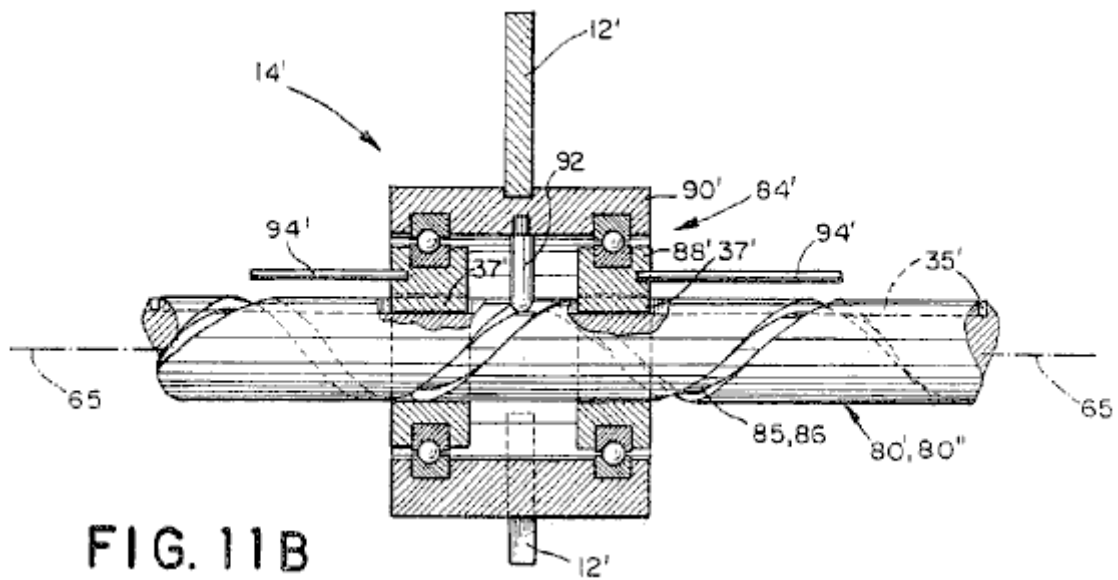

FIG. 11B

Fig.11B is a plan view of a rotor assembly used in the twelfth through a sixteenth preferred embodiment;

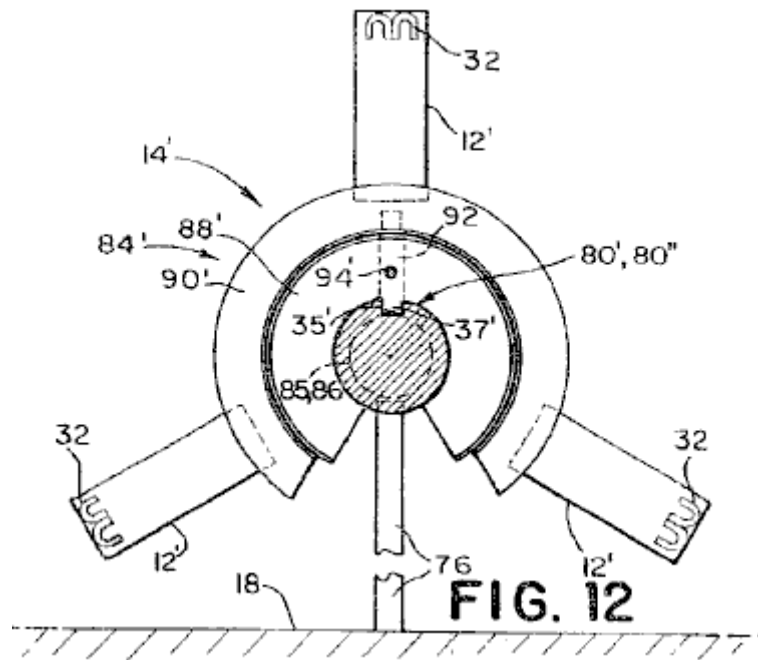

Fig.12 is an end elevational view of the rotor assembly shown in Fig.11B, further including a rail mounting post;

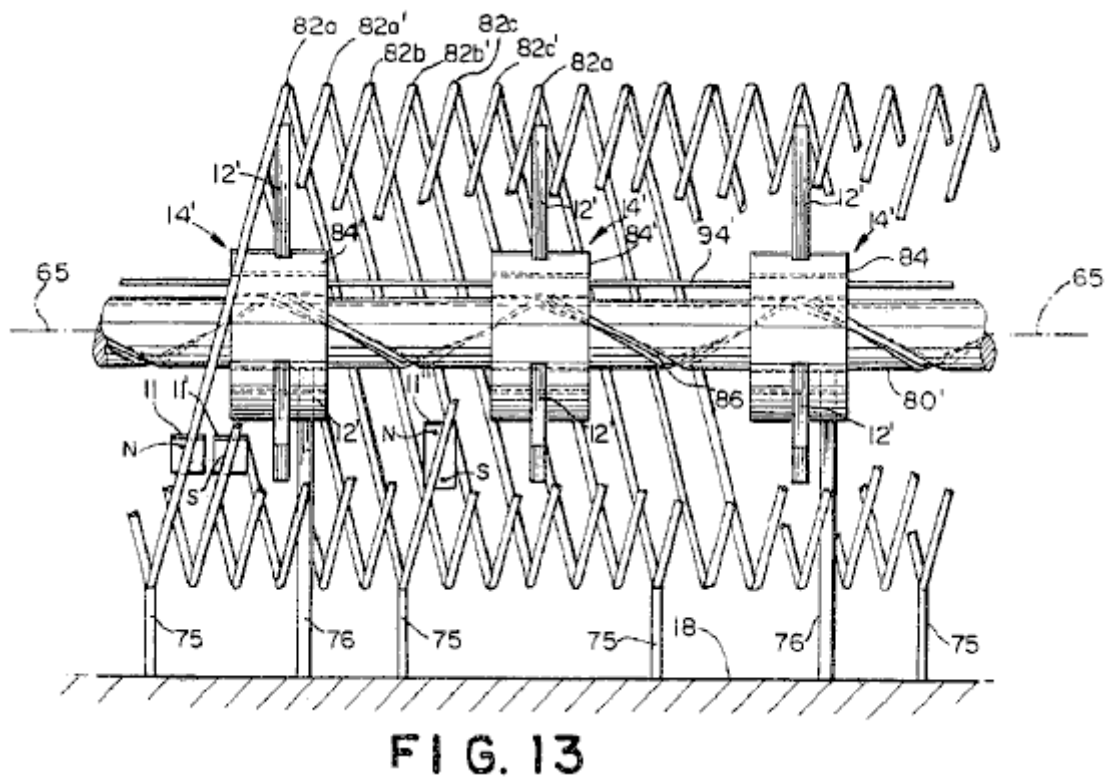

Fig.13 is an elevational view of a thirteenth preferred embodiment of the motor;

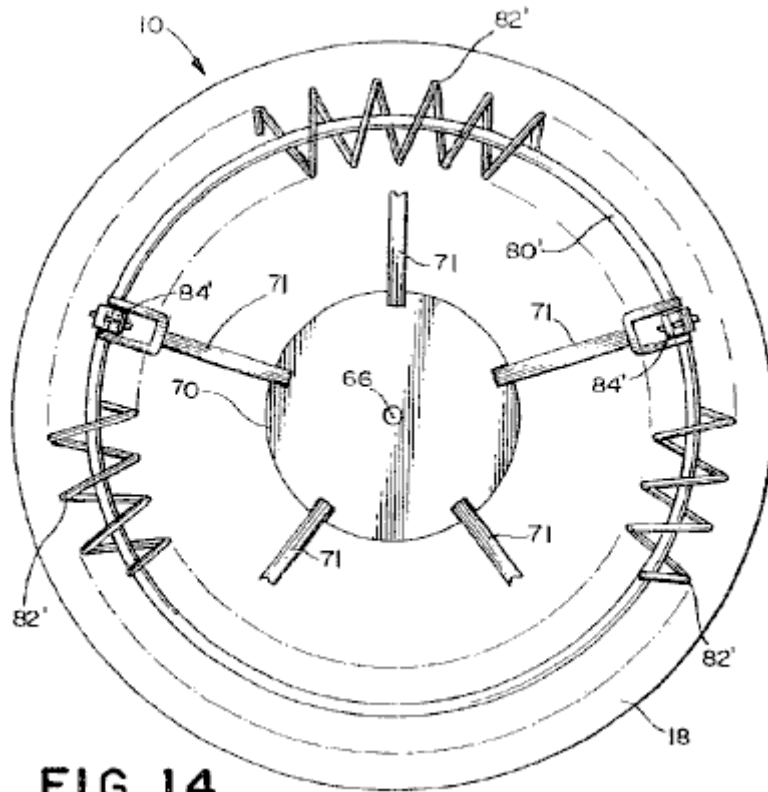

FIG. 14

Fig.14 is a plan view of a rotary configuration of the thirteenth preferred embodiment;

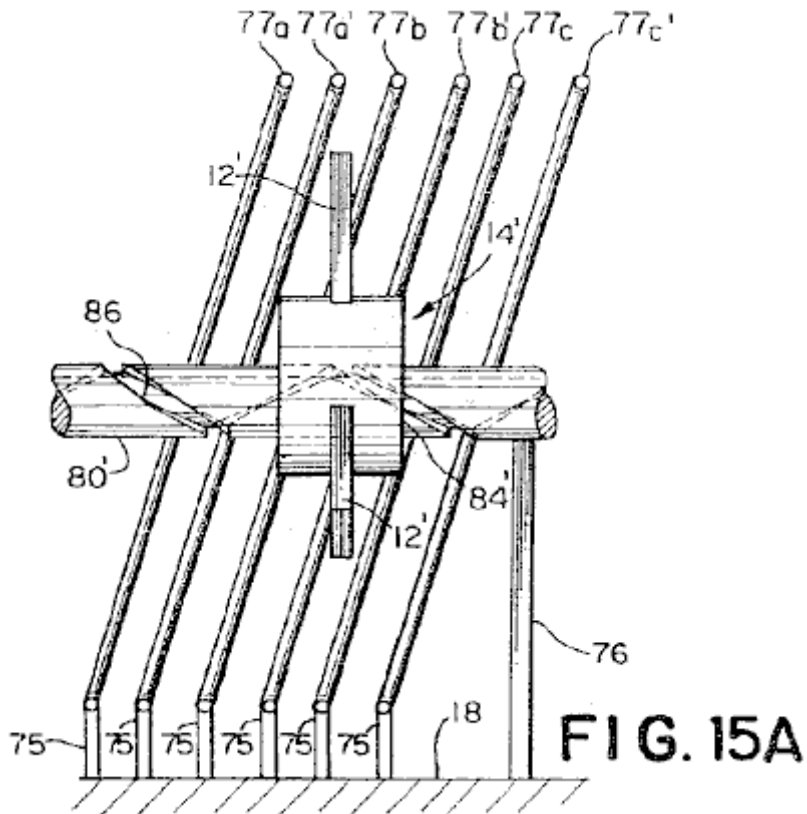

FIG. 15A

Fig.15A is an elevational view of a portion of a fourteenth preferred embodiment employing spaced apart ribs;

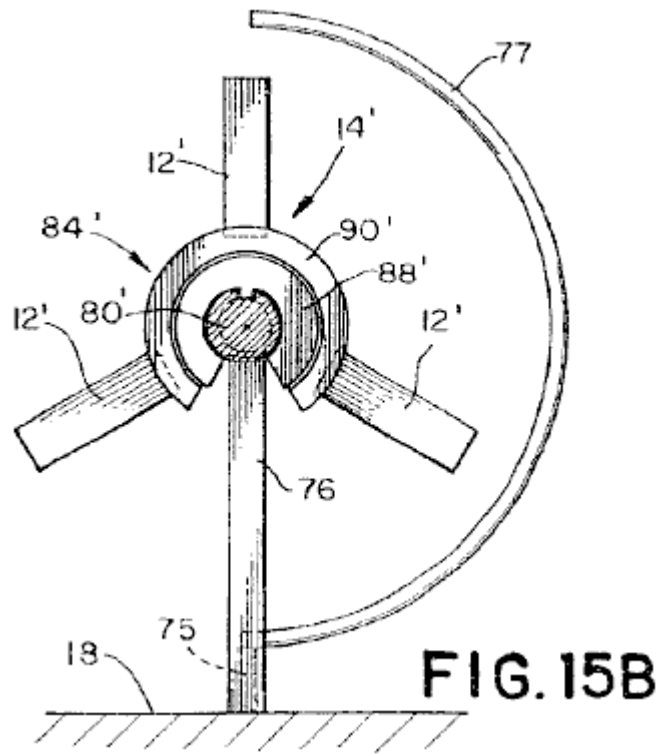

Fig.15B is an end elevational view of the fourteenth embodiment shown in Fig.15A;

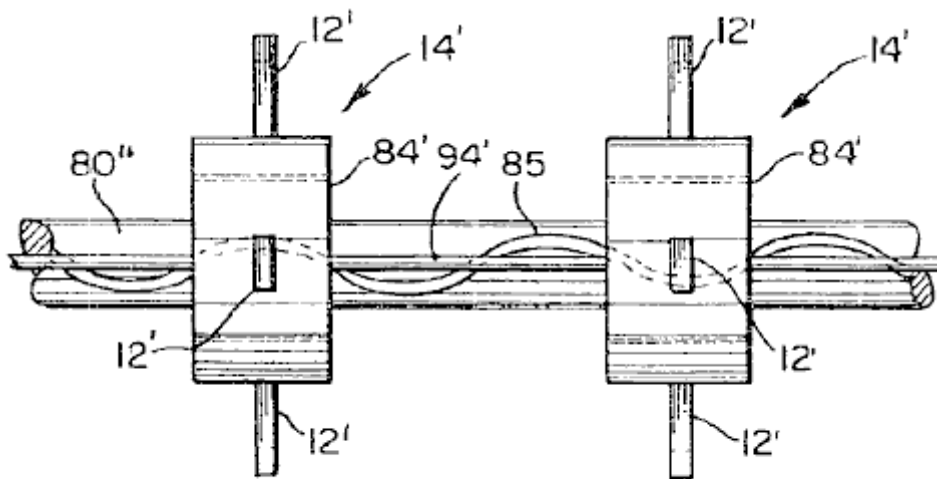

FIG. 16

Fig.16 is a top plan view of a portion of the fifteenth preferred embodiment of the motor;

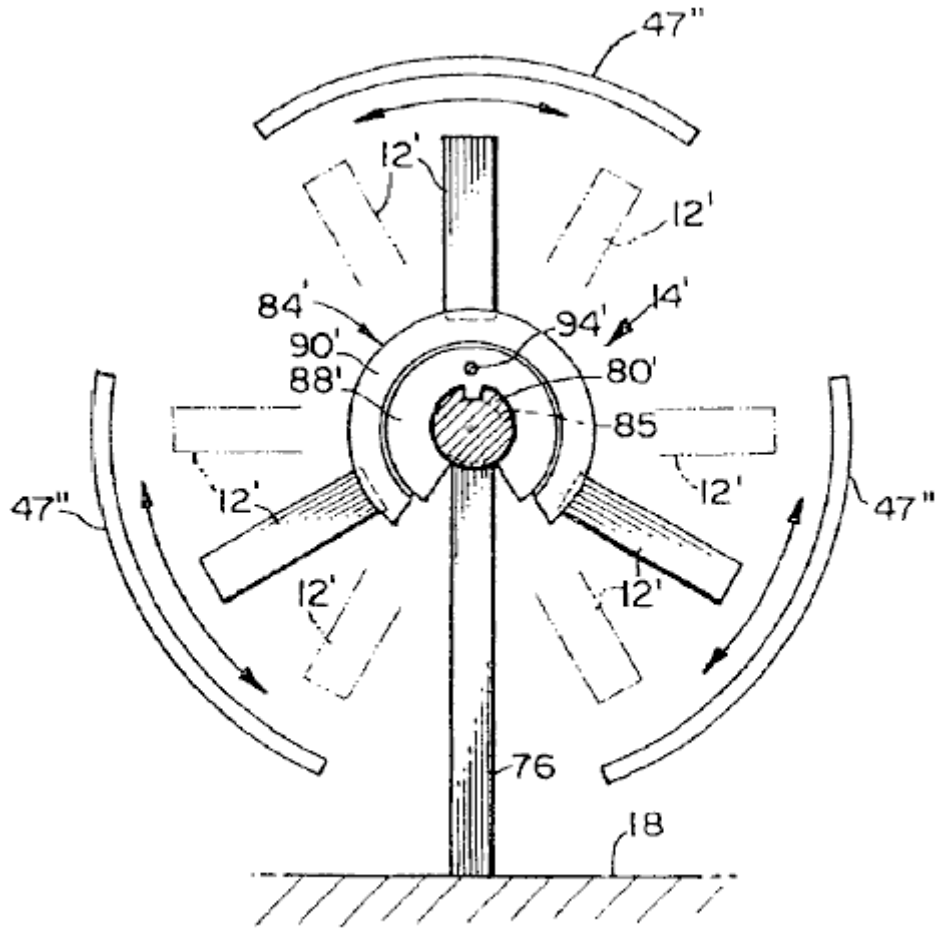

FIG. 17

Fig.17 is an elevational end view of the fifteenth preferred embodiment shown in Fig.16;

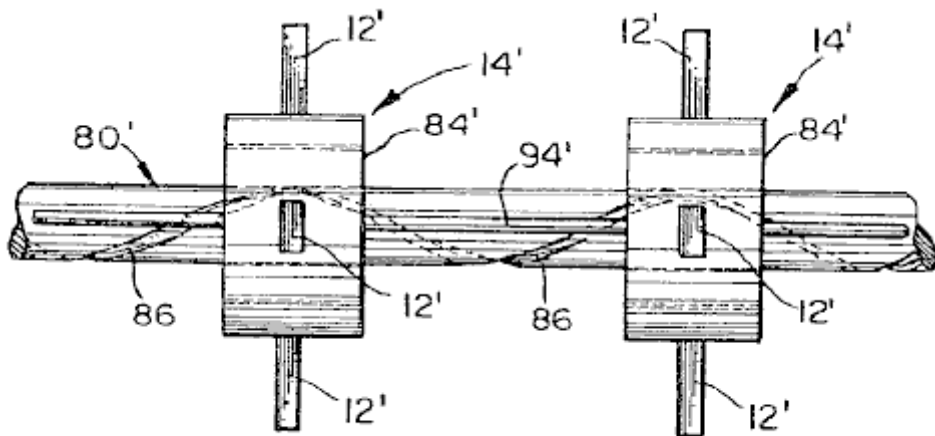

FIG.18

Fig.18 is a top plan view of a portion of the sixteenth preferred embodiment of the motor; and

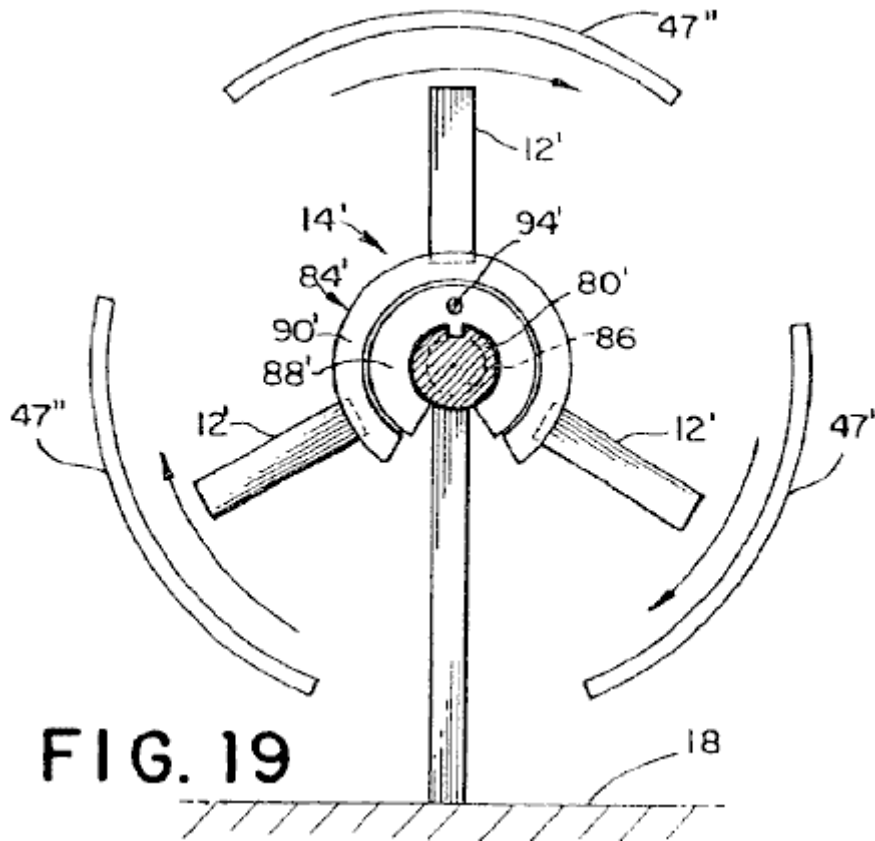
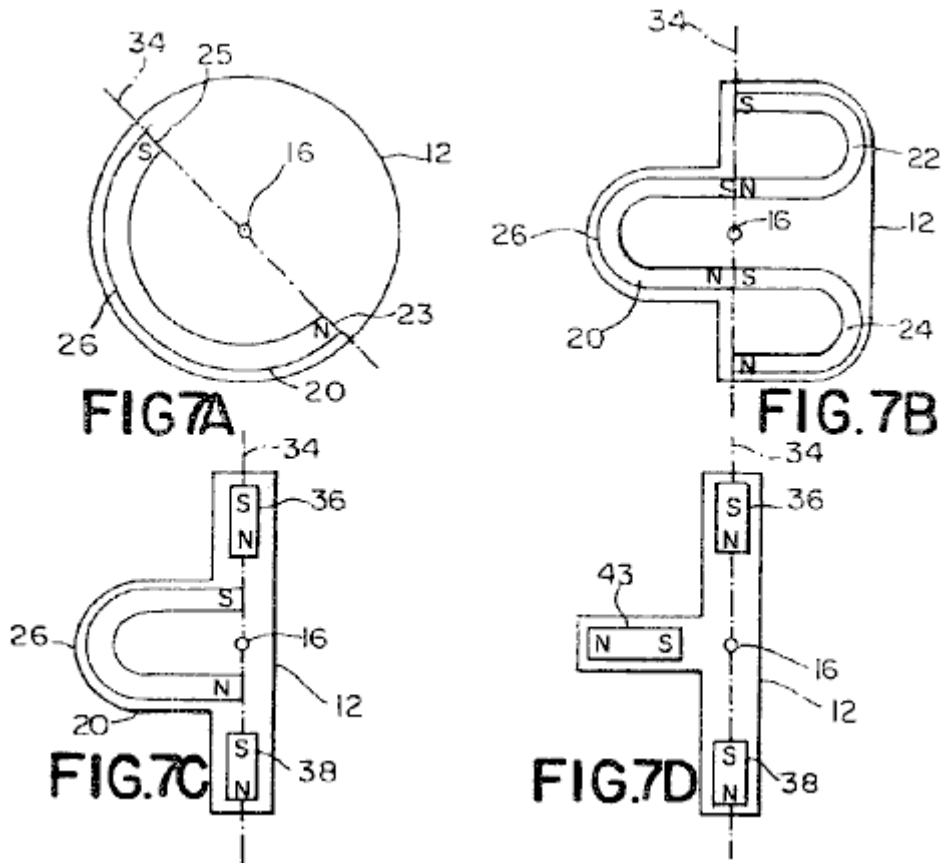

Fig.19 is an elevational end view of the sixteenth preferred embodiment of the motor shown in Fig.18.

DETAILED DESCRIPTION OF THE INVENTION

It will be appreciated by those skilled in the art that changes could be made to the embodiments described above without departing from the broad inventive concept thereof. It is understood, therefore, that this invention is not limited to the particular embodiments disclosed, but it is intended to cover modifications within the spirit and scope of the present invention as defined by the appended claims. It should also be understood that the articles "a" and "the" used in the claims to define an element may refer to a single element or to a plurality of elements without a limit as to the number of elements.

Past attempts to construct a working permanent magnet motor have met with difficulties because of the simultaneous attractive and repulsive characteristics of a permanent magnet. A principle has been discovered where, by engaging a magnetic field at the rear of one or more U-shaped magnets mounted on a rotor with a second stationary magnetic field, a torque is created that rotates the rotor about a rotational axis of the rotor. Further, by properly shaping the second magnetic field, the rotor may be caused to also translate in the direction of the rotor axis.



Accordingly, using the aforementioned principle, and referring to **Fig.7A**, one aspect of the present invention is directed to a rotor **12** for use in a motor and which provides motive power by a rotation of the rotor **12** about a rotor axis **16** and by a translation of the rotor **12** in a direction of the rotor axis **16**. In one aspect, the rotor **12** comprises a first U-shaped magnet **20** in which the U-shaped magnet **20** generates a first magnetic field. A rotation of the rotor **12** about the rotor axis **16** is caused by an interaction of a portion of the first magnetic field directly adjacent to a rear **26** of the U-shaped magnet **20** with a stationary second magnetic field. A translation of the rotor **12** in the direction of the rotor axis **16** is caused by an interaction of the first magnetic field adjacent to a north pole **23** and a south pole **25** of the U-shaped magnet **20** with the stationary second magnetic field. As will be appreciated by those skilled in the art, the design of the rotor **12** is not limited to a single U-shaped magnet **12**. A plurality of U-shaped magnets **20**, arranged around a periphery of the rotor **12** is within the spirit and scope of the invention.

Another aspect of the present invention, shown in **Fig.7B** comprises a rotor **12** including a first U-shaped magnet having a north pole and a south pole generating a first magnetic field; a second U-shaped magnet **24** having a north pole and a south pole with the south pole of the second U-shaped magnet **24** abutting the north pole of the first U-shaped magnet **20**; and a third U-shaped magnet **22** having a north pole and a south pole with the north pole of the third U-shaped magnet **22** abutting the south pole of the first U-shaped magnet **20**. A portion of the first magnetic field generated by the first U-shaped magnet **20** directly adjacent to the rear **26** of the first U-shaped magnet **20** interacts with a stationary fourth magnetic field to cause the rotor **12** to rotate. A second magnetic field generated by the north pole of the second U-shaped magnet **24** and a third magnetic field generated by the south pole of the third U-shaped magnet **22** respectively interact with the fourth magnetic field to cause the rotor **12** to translate in the direction of the rotor axis **16**.

A further aspect of the present invention, shown in **Fig.7C**, comprises a first U-shaped magnet **20** having a north pole and a south pole generating a first magnetic field. The north pole and the south pole of the U-shaped magnet **20** are generally aligned with a thruster axis **34** which lies in the plane of the rotor **12** and intersects the rotor axis **16**. A first thruster magnet **36** is located proximate to and spaced from the north pole of the first U-shaped magnet with a direction of magnetisation being generally aligned with the thruster magnet axis **34**. A second thruster magnet **38** is located proximate to and spaced from the south pole of the first U-shaped magnet **20** with a direction of magnetisation also being generally aligned with the thruster magnet axis **34**. A portion of the first magnetic field generated by the first U-shaped magnet **20** directly adjacent to the rear side **26** of the first U-shaped magnet **20** interacts with a stationary fourth magnetic field to cause the rotor **12** to rotate. A second magnetic field generated by both the north pole and the south pole of the first thruster magnet **36** and a third magnetic field generated by both the north pole and the south pole of the second thruster magnet **38** respectively interact with a fifth magnetic field to cause the rotor **12** to translate in the direction of the rotor axis **16**. In one

further aspect of the rotor 12, as shown in Fig.7D, a bar magnet 43 may be substituted for the U-shaped magnet 20 and the fourth magnetic field is formed by one or more U-shaped magnets, where the bar magnet 43 interacts with a portion of the stationary fourth magnetic field adjacent to the rear of a U-shaped magnet.

As will be appreciated by those skilled in the art, the polarities of the magnets shown in Figs. 7A, 7B, 7C and 7D may be reversed and still be within the spirit and scope of the invention.

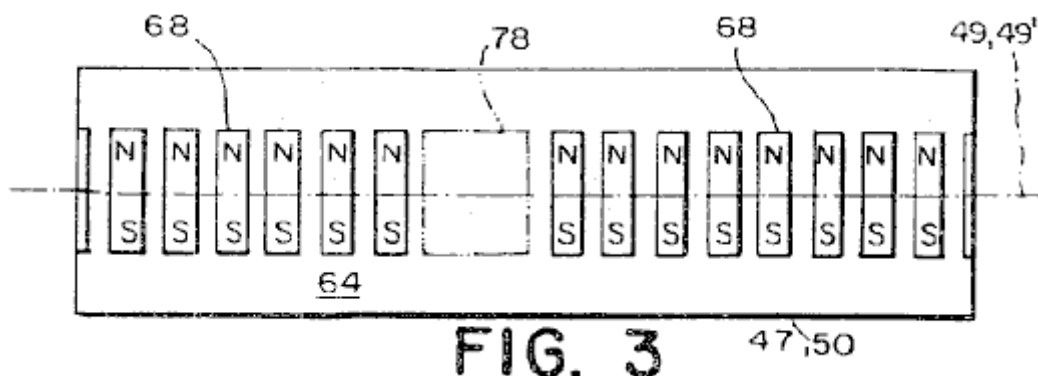
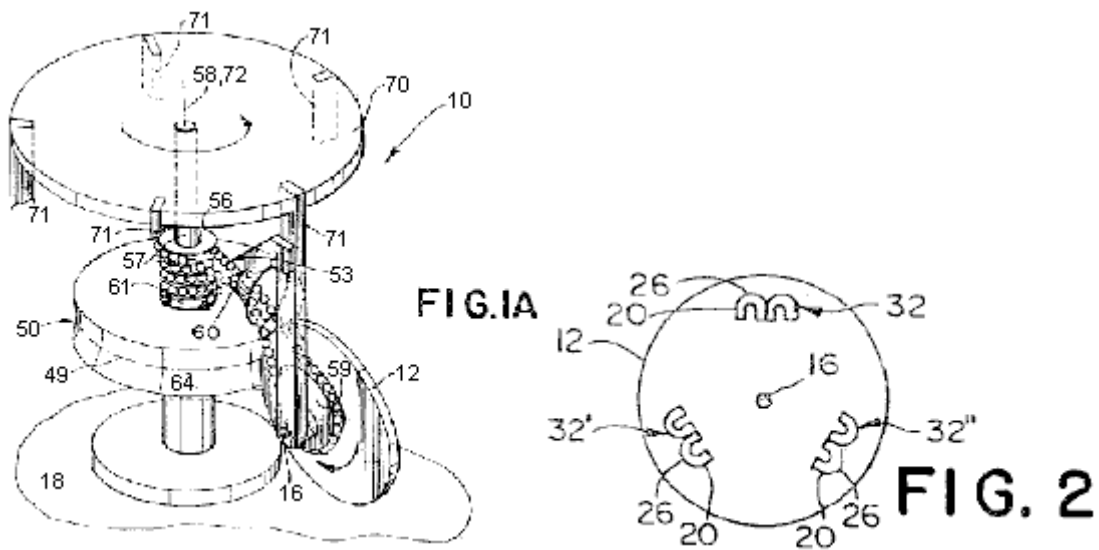

Referring now to Fig.1A, Fig.2 and Fig.3 there is shown a first preferred embodiment of a motor 10 using the rotor 12 and providing unidirectional rotational motive power. The first preferred embodiment comprises a generally circular stator 50 having a stator axis 72 and a circumferential surface 64 mounted to a base 18; an armature 70, having an armature axis of rotation 58 coincident with the stator axis 72, attached to the stator 50 by an armature axle 57 for rotation about the armature axis of rotation 58; and five rotors 12 (only one of which is shown for clarity), the rotors 12 being spaced at intervals of about 72 degrees around the armature 70. Each rotor 12 is spaced from the armature by an armature strut 71 and attached to the armature strut 71 by an axle, for rotation about an axis 16 of the rotor 12 in a plane generally aligned with the armature axis of rotation 58. The motor 10 further includes a driving linkage assembly 53 connecting each rotor 12 and the stator 50 together, the linkage 53 urging the armature 70 to rotate about the armature axis of rotation 58 as each rotor 12 rotates about its respective rotor axis 16. As will be appreciated by those skilled in the art the number of rotors 12 is not limited to the five rotors 12 disclosed in the first embodiment. Any number of rotors 12 from one to as many as there would be space for mounting on the armature 70 is within the spirit and scope of the invention.

Preferably, the surface 64 of the stator 50 is curved, having a curvature conforming to the arc of the rotors 12. However, it will be appreciated by those skilled in the art that the surface 64 need not be curved but could be planar and still be within the spirit and scope of the invention. As will be appreciated by those skilled in the art the stator 50 is merely intended as a stationary supporting structure for stator magnets and, as such, the shape of the stator 50 is not intended to be controlling of the size and shape of the air gap between the magnets attached to the stator 50 and the magnets attached to the rotors 12.

Preferably, the stator 50 is made of a material (or a combination of materials) having a magnetic susceptibility less than 10⁻³, i.e. a material displaying paramagnetic or diamagnetic properties. For example, the stator 50 could be

made of a non-magnetic metal such as aluminium or brass. Also, the rotor 12 could be made of a natural material such as wood, glass, a polymeric material or a combination of any of the aforementioned materials within the spirit and scope of the invention. Further, it should be understood that the aforementioned materials are preferred for the stators and all other parts of the motor 10 that could significantly disrupt the magnetic interaction between the stator and the rotor of all of the disclosed preferred embodiments of the motor 10.

In the first preferred embodiment, the surface 64 of the stator 50 includes a circumferential line of demarcation 49 at about a midpoint of the surface 64 formed by an intersection with the surface 64 of a plane perpendicular to the armature axis of rotation 58. As shown in Fig.3, the stator 50 includes a plurality of bar magnets 68 attached to the outer surface 64 along the line of demarcation 49, except in a single null region 78 where the magnitude of the first magnetic field is substantially reduced. The bar magnets 68 have a direction of magnetisation at about a right angle to the line of demarcation 49 thereby creating a first magnetic field adjacent to the outer surface 64, the magnitude and the direction of which is substantially uniform along the circumferential line of demarcation 49 around the axis 58 of the stator 50, except within the null region 78. As will be appreciated by those skilled in the art, the stator axis 72 need not be coincident with the armature axis of rotation 58. Accordingly, a stator 50 arranged around the armature axis 58 at any location at which the stator axis 72 is parallel to the armature axis 58 and the surface 64 of the stator 50 faces the periphery of the rotors 12 thereby providing for the interaction between the first magnetic field and the second magnetic field around the armature axis 58, is within the spirit and scope of the invention.

Preferably, as further shown in Fig.3, the bar magnets are attached to the surface 64 of the stator 50 so that the direction of magnetisation of the bar magnets 68 are about perpendicular to a radial line of the rotor 12. However, the bar magnets 68 could also be attached to the surface 64 of the stator so that the direction of magnetisation of the bar magnets 68 is aligned with a radial line of the rotor 12. The bar magnets 68 are preferably abutting so as to form the substantially uniform first magnetic field. However, it is not necessary for the bar magnets 68 to abut one another. Further, it is not necessary to use a plurality of bar magnets 68 to form the first magnetic field. A single magnet producing a uniform first magnetic field in the region in which the first magnetic field interacts with the second magnetic field of the rotors 12 would provide the required first magnetic field. Also, the number of null regions 78 may be more than one, depending upon the desired speed of the motor, as explained below.

Preferably, the stator magnets 68 are permanent magnets made of a neodymium-iron-boron material. However, as will be appreciated by those skilled in the art, any type of permanent magnet material displaying ferromagnetic properties could be used for the stator magnets 68. For instance, stator magnets 68 made of samarium cobalt, barium ferrite or AlNiCo are within the spirit and scope of the invention. It should be understood that these permanent magnet materials or their equivalents are preferred for the stator magnets and the rotor magnets of all of the disclosed preferred embodiments of the motor 10. Also, while the use of permanent magnets is preferred, the use of electro-magnets for some or all of the magnets is within the spirit and scope of the invention.

As discussed above, the stator 50 may include a pre-determined number of null regions 78 on the surface of the stator 64. In the first preferred embodiment, the single null region 78 is formed by a shield of a ferromagnetic material, such as iron, placed adjacent to the surface 64. However, as those skilled in the art will appreciate, the null region 78 can also be formed by an absence of the bar magnets 68 in the region coinciding with the null region 78. The null region 78 of substantially reduced magnetic field magnitude may also be formed by an auxiliary magnetic field suitably generated by one or more permanent magnets or by one or more electromagnets powered by an electric current arranged so that the auxiliary magnetic field substantially cancels the first magnetic field in the null region 78. In the case of the electromagnets, the electric current may be turned off in synchronism with the rotation of the rotors 12 passing through the null region 78, in order to conserve power. Preferably, the first magnetic field is reduced to ten percent or less of the magnetic force outside of the null region. However, the motor 10 will operate with a reduction of only fifty percent. Accordingly, a motor 10 having a substantial reduction of the first magnetic field of fifty percent or less is within the spirit and scope of the invention.

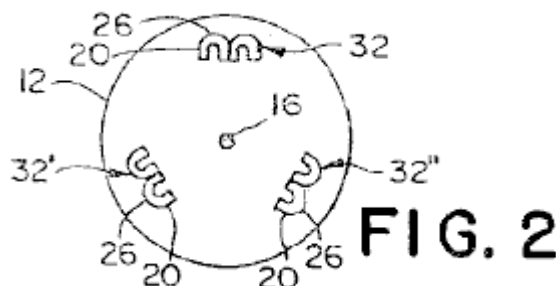

As shown in Fig.2, the rotor 12 of the first preferred embodiment includes three pairs 32, 32', 32'' of abutted U-shaped magnets 20 spaced apart at about 120 degree intervals around the periphery of the rotor 12. Preferably,

the U-shaped magnets **20** having substantially identical magnetic properties and are arranged to have opposite poles of the abutting each other. The pairs **32, 32', 32''** of abutted U-shaped magnets **20** are positioned so that the north pole and the south poles of each U-shaped magnet **20** face toward the axis of the rotor **16**, and the rear side **26** of each U-shaped magnet **20**, opposite to the north and the south pole of the U-shaped magnet **20**, faces out from the axis of the rotor **16** toward the surface **64** of the stator **50**. The pairs **32, 32', 32''** of the U-shaped magnets **20** are situated on the rotor **12** so that a portion of the second magnetic field directly adjacent to the rear **26** of each U-shaped magnet **20** interacts with a first stationary magnetic field to cause the rotor **12** to rotate about its respective rotor axis **16**. Those skilled in the art will appreciate that it is not necessary to have exactly three pairs **32, 32', 32''** of U-shaped magnets **20** on the rotor **12**. For instance, the number of U-shaped magnets **20** (or groups of abutted U-shaped magnets) spaced apart around the periphery of the rotor **12** may range from merely a single U-shaped magnet **20**, up to a number of magnets limited only by the physical space around the periphery of the rotor **12**. Further, the number of abutted U-shaped magnets **20** within each group of magnets **32** is not limited to two magnets but may also range from 1 up to a number of magnets limited only by the physical space around the periphery of the rotor **12**.

Preferably, the rotor **12** is made of a material (or a combination of materials) having a magnetic susceptibility less than 10-3. Accordingly, the rotor could be made of any of the same materials used to make the stator, such as for instance, a non-magnetic metal, wood, glass, a polymeric or a combination of any of the above as shown in **Fig.1A**, the rotor **12** is preferably disk shaped with the rear **26** of the U-shaped rotor magnets **20** being arranged on the periphery of the rotor **12** in such a way that the U-shaped magnets **20** pass in close proximity to the circumferential line of demarcation **49** on the outer surface **64** of the stator **50** as the rotor **12** rotates. However, as will be clear to those skilled in the art, the structure of the rotor **12** need not be disk shaped. The rotor **12** could be a structure of any shape capable of rotating around the rotor axis **16** and capable of supporting the U-shaped magnets **20** so that, as the rotor **12** rotates, the U-shaped magnets **20** come into close proximity with the outer surface **64** of the stator **50**. For example, a rotor **12** comprised of struts connected to a central bearing, where each strut holds one or more U-shaped magnets **20**, is within the spirit and scope of the invention.

In the first preferred embodiment, the linkage **53** connecting each rotor **12** and the stator **50** comprises a beaded chain drive **60** which meshes with a stator sprocket **61** on the stator **50**, and an eccentric rotor sprocket **59** on each rotor **12** so that, as each rotor **12** rotates about its respective rotor axis **16**, the armature **70** is forced to rotate about the armature axis of rotation **58**. The eccentric rotor sprocket **59** causes the instantaneous angular velocity of the rotor **12** about the rotor axis **16** to increase above the average angular velocity of the rotor **12** as each pair **32, 32', 32''** of U-shaped magnets **20** passes through the null region **78**. As will be appreciated by those skilled in the art, the rotor sprocket **59** could be circular and the stator sprocket **61** eccentric and still cause the angular velocity of the rotor **12** to increase. Further, the beaded chain **60** in combination with the stator sprocket **61** and the eccentric rotor sprocket **59** are not the only means for connecting each rotor **12** to the stator **50**. For instance, the beaded chain **60** could also be a belt. Further, the linkage **53** could comprise a drive shaft between each rotor **12** and the stator **50**, the drive shaft having a bevel gear set at each end of the shaft mating with a bevel gear on the rotor **12** and the stator **50**. An automatic gear shift mechanism would shift gears as each U-shaped magnet pair **32, 32', 32''** entered the null regions **78** to increase the instantaneous angular velocity of the rotor **12** as the pair **32, 32', 32''** of rotor magnets **20** passed through the null region **78**. Alternatively the linkage **53** could comprise a transmission system employing elliptical gears.

While it is preferred that the instantaneous angular velocity of the rotor **12** to increase above the average angular velocity of the rotor **12** as each pair of U-shaped magnets **20** passes through the null region **78**, it is not necessary to provide the increased angular velocity of the rotor **12** to provide motive power from the motor **10**.

Preferably, the diameters of the rotor sprocket **59** and stator sprocket **61** are selected so that the rear **26** of each U-shaped magnet **20** passes through one and only one null region **78** for each full revolution of the rotor **12** about the respective rotor axis **16** as the armature **70** rotates about the armature axis of rotation **58**. Accordingly, the revolution rate of the armature **70** is related to the revolution rate of the rotor **12** by the expression:

$$S_a = (N_r / N_s) \times S_r \dots\dots\dots (1)$$

Where:

S_a is the angular velocity of the armature **70** (RPM);

N_r is the number of the U-shaped magnets **20** (or groups of abutted U-shaped magnets **32**) on a rotor **12**;

N_s is the number of null regions **12** on the stator **50**; and

S_r is the angular velocity of the rotor **12** (RPM).

The timing of the rotation of the rotor **12** around its respective rotor axis **16**, and the armature **70** about the armature axis of rotation **58** is such that each U-shaped magnet **20** (or U-shaped magnet pair **32, 32', 32''**) on each rotor **12** enters into a null region **78** at a point where the magnetic interaction between the first magnetic field

and the second magnetic field is substantially reduced, thus providing a commutation of the second magnetic field. As each rotor 12 continues to rotate about the rotor axis 16 and the armature 70 rotates about the armature axis of rotation 58, the U-shaped magnet 20 traces a slanted path through the null region 78. As the U-shaped magnet emerges from the null region 78, the U-shaped magnet 20 encounters the strong first magnetic field, which urges the U-shaped magnet 20 to continue the rotation of the rotor 12 about the rotor axis 16.

As previously discussed, the first preferred embodiment of the motor 10 comprises a single null region 78 and five rotors 12, each rotor 12 having three pairs 32, 32', 32'' of abutted U-shaped magnets 20. Preferably, the rotors 12 are uniformly spaced around the armature axis of rotation 58 and the pairs 32, 32', 32'' of U-shaped magnets 20 are uniformly spaced around the periphery of each respective rotor 12. Further, the pairs 32, 32', 32'' of U-shaped magnets 20 on each rotor 12 are phased with respect to each other by one-fifth of a revolution of the rotor 12 (i.e. the reciprocal of the number of rotors) so that the pairs 32, 32', 32'' of U-shaped magnets 20 of all the rotors 12 enter the null region at substantially uniform intervals to provide a more or less continuous magnetic interaction between the first magnetic field of the stator 50 and the second magnetic field of the rotors 12. As will be appreciated by those skilled in the art, the motive power provided by the motor is proportional to the number of rotors 12 and the number of magnets 20 on each rotor 12 as well as the strength of the rotor 12 magnets 20 and the stator 50 magnets 68. Accordingly, the number of rotors 12 and the number of pairs 32, 32', 32'' of U-shaped magnets 20 are not limited to five rotors 12 and three pairs 32, 32', 32'' of U-shaped magnets 20. Similarly, the number of null regions 78 is not limited to one. The number of U-shaped magnets 20 and the number of null regions 78 are limited only by adherence to the rule established by Equation (1).

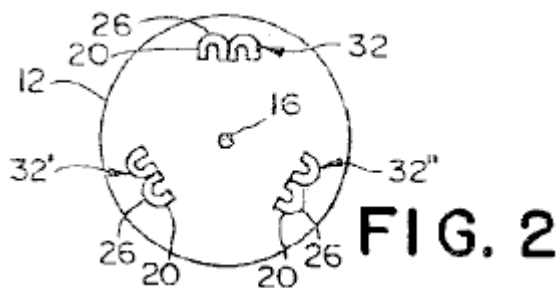
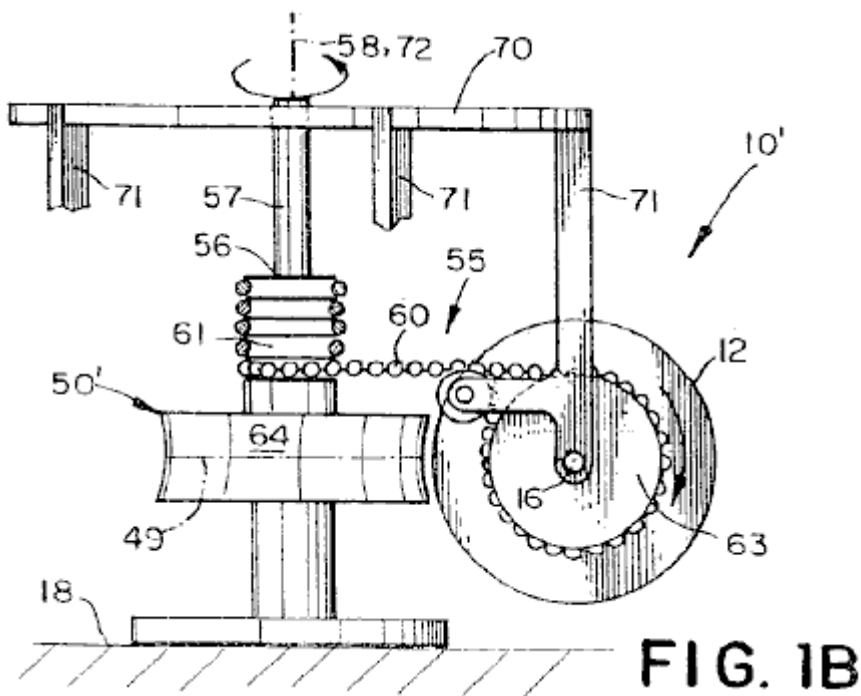

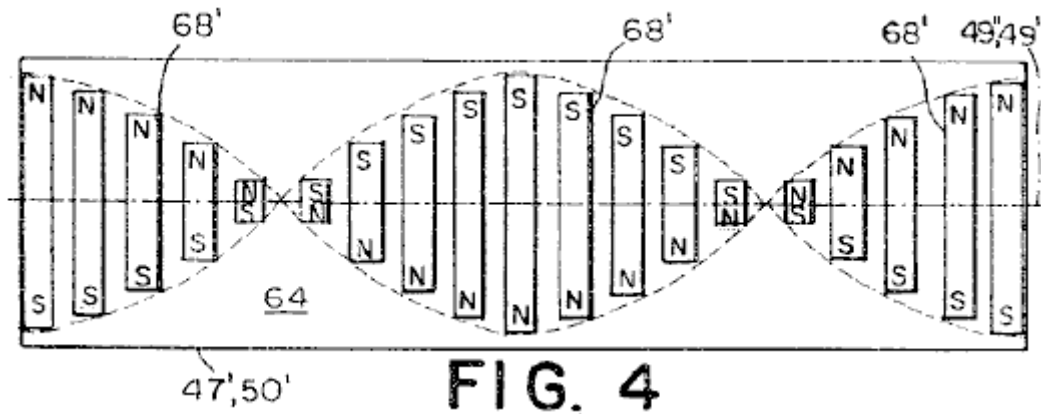

Referring now to **Fig.1B**, **Fig.2** and **Fig.4** there is shown a second preferred embodiment of a motor **10** providing unidirectional rotational motive power. The second preferred embodiment comprises a generally circular stator **50'** having a stator axis **72** with magnets **68'** attached to a surface **64** of the stator **50'**; an armature **70** attached to the stator **50'** by an armature axle **57** for rotation about an armature axis of rotation **58** coincident with the stator axis **72**; and five rotors **12** (for clarity, only one of which is shown) having three pairs **32**, **32'**, **32''** of abutted U-shaped magnets **20**, the rotors **12** being spaced at intervals of about **72** degrees around the armature **70**. Each rotor **12** is spaced from the armature by a strut **71** and attached to the strut **71** by an axle for rotation in the plane of the armature axis of rotation **58** about a rotor **12** axis of rotation **16**. The motor **10** further includes a driving linkage **55** connecting each rotor **12** and the stator **50** together to cause the armature **70** to rotate about the armature axis of rotation **58** as each rotor **12** rotates about its respective rotor axis **16**.

The second preferred embodiment is identical to the first preferred embodiment except for two differences. First, instead of the first magnetic field being uniform in both magnitude and direction along the circumferential line of demarcation **49** (except in one or more null regions **78** as in the first preferred embodiment), the direction of the first magnetic field rotates about a magnetic axis parallel to the circumferential line of demarcation **49** with a pre-determined periodicity along the line of demarcation **49**. Preferably, the first magnetic field is formed from one or more stator magnets **68'** attached to the outer surface **64** of the stator **50'**, each magnet **68'** having a direction of magnetisation which causes the first magnetic field to rotate about the magnetic axis. In the second preferred embodiment, as shown in **Fig.4**, the stator magnets **68'** are equally sized bar magnets, attached to the stator **50'** so that the bar magnets **68'** spiral on the stator **50'** with the pre-determined periodicity. However, as would be apparent to those skilled in the art, the first magnetic field need not be formed by bar magnets but could be formed from a single magnet (or groups of magnets) such that the direction of magnetisation of the single magnet rotates around the magnetic axis.

The second difference between the first preferred embodiment and the second preferred embodiment is that the linkage **55** of the second preferred embodiment does not include a component for increasing the angular velocity of the rotor **12** above the average velocity of the rotor **12**. Accordingly, in the second preferred embodiment, a circular rotor sprocket **63** is used in place of the eccentric rotor socket **59**, thereby providing a constant rate of rotation of the rotor **12** about the rotor axis **16** as the armature **70** rotates about the stator **50'**.

As will be clear to those skilled in the art, the rotation of the direction of the first magnetic field around the circumferential line of demarcation **49** commutates the second magnetic field, overcoming the need for the null regions **78**. In all other respects, the operation of the second embodiment is the same as that of the first embodiment. That is, the revolution rate of each rotor **12** is related to the revolution rate of the armature **70** by **Equation (1)**, where the parameter **Ns** is the number of rotations around the line of demarcation **49** of the first magnetic field along the line of demarcation **49**. In the second preferred embodiment, as shown in **Fig.4**, the number of rotations of the first magnetic field is one. Accordingly, since there are three pairs **32**, **32'**, **32''** of U-shaped magnets **20**, each of the five rotors **12** makes one-third revolution for each full revolution of the armature **70** around the armature axis **58**. However, as will be appreciated by those skilled in the art, the motor **10** could be designed for the first magnetic field to have any number of whole periods of rotation about the armature axis **58** provided that the revolution rate of the rotors **12** was adjusted to conform to **Equation (1)**.

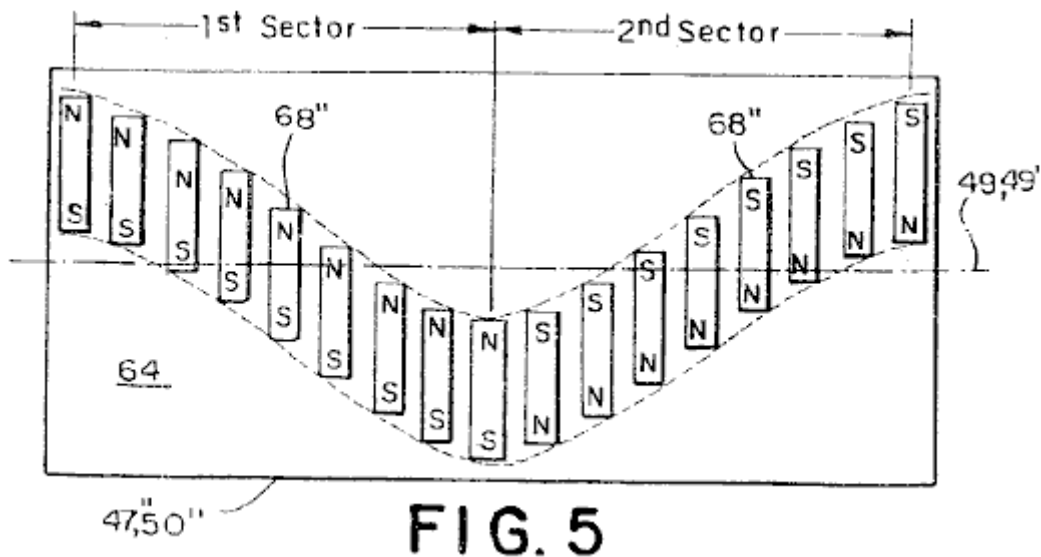
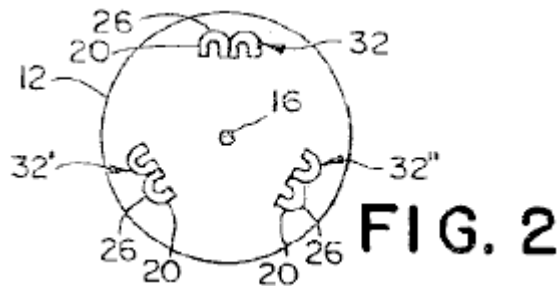
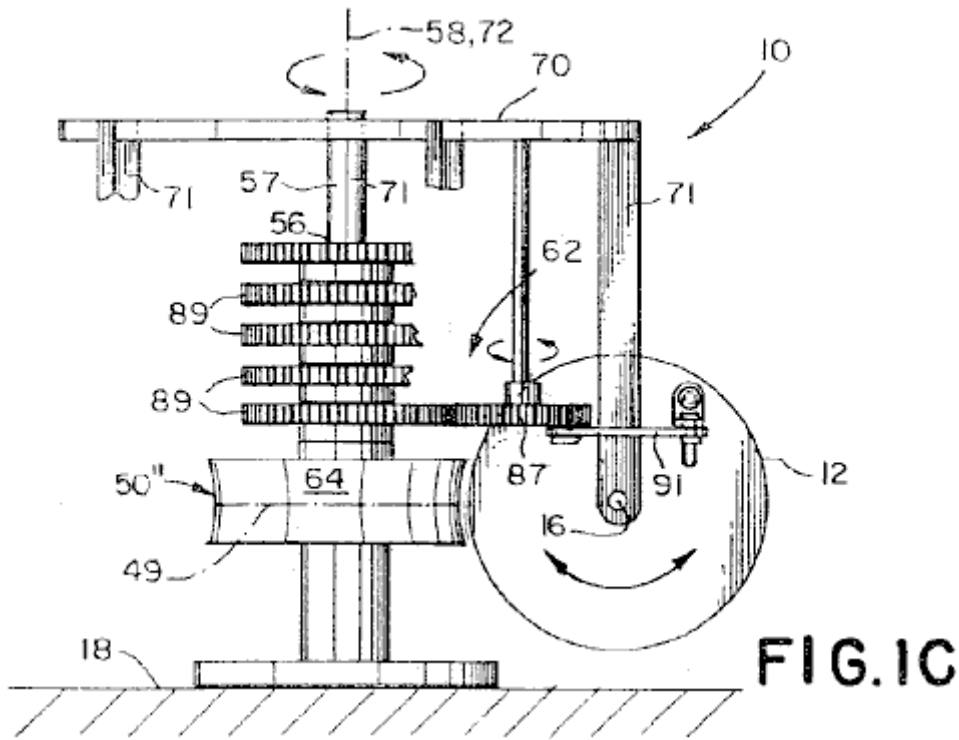

Referring now to **Fig.1C**, **Fig.2** and **Fig.5** there is shown a third preferred embodiment of a motor **10** providing unidirectional rotational motive power. The third preferred embodiment comprises a generally circular stator **50''** mounted to a base **18** and having an axis **72**, with magnets **68''** attached to the surface **64** of the stator **50''**, an armature **70** attached to the stator **50''** by an axle **57** for rotation about an armature axis of rotation **58** coincident with the stator axis **12**, and five rotors **12** (for clarity, only one of which is shown) having three pairs **32, 32', 32''** of abutted U-shaped magnets **20**, the rotors **12** being spaced at intervals of about **72** degrees around the armature **70**. Each rotor **12** is spaced from the armature by an armature strut **71** and attached to the armature strut **71** by an axle for rotation about an axis **16** of the rotor **12** in a plane generally aligned with the armature axis **58** about

an axis **16** of the rotor **12**. The motor **10** further includes a driving linkage **62** connecting each rotor **12** and the stator **50** together to cause the armature **70** to rotate about the armature axis of rotation **58** as each rotor **12** oscillates about its respective rotor axis **16**.

The third preferred embodiment is identical to the first preferred embodiment except for three differences. First, instead of the first magnetic field being uniform in both magnitude and direction around the circumferential line of demarcation **49** (except in the null zone **78**), the first magnetic field is displaced by a sinusoidal pattern having a pre-determined peak amplitude and a pre-determined period along the circumferential line of demarcation **49**, with the direction of the first magnetic field alternating in opposite directions along the line of demarcation **49** between each peak amplitude of the sinusoidal pattern.

Preferably, as shown in **Fig.5** the first magnetic field is formed by a plurality of bar magnets **68"** arranged on the surface **64** of the stator **50"** so that the magnetisation of the bar magnets **68"** is displaced in the sinusoidal pattern from the line of demarcation **49** around the circumferential line of demarcation **49**. The sinusoidal pattern of the bar magnets **68"** is divided into first and second sectors, the boundary of which occurs at the peaks of the sinusoidal pattern. The direction of magnetisation of the bar magnets **68"** is opposite in direction in the first and the second sectors providing a commutation of the second magnetic field and causing the rotors **12** to reverse in rotational direction as the rotor **12** oscillates around the rotor axis **16** and rotates around the armature axis of rotation **58**.

Preferably, the sinusoidal pattern of the magnets has a predetermined peak amplitude so that each rotor **12** oscillates approximately +/-thirty (30) degrees from a neutral position. However, the value of the peak amplitude is not critical to the design of the motor **10**. Further, the predetermined period of the sinusoidal pattern may be selected to be any value for which the number of cycles of the sinusoidal pattern around the surface **64** of the stator **50"** is an integer value.

As will be apparent to those skilled in the art, the first magnetic field need not be formed by the bar magnets **68"** but could be formed from a single magnet (or groups of magnets) so that the first magnetic field would be sinusoidally displaced around the armature axis of rotation **58** and would alternate in opposite directions between each peak of the sinusoidal pattern. Further, as will be appreciated by those skilled in the art, the displacement of the first magnetic field need not be precisely sinusoidal. For instance the displacement may be in a shape of a sawtooth or in a shape having a portion with constant plus and minus amplitude values, within the spirit and scope of the invention.

As a result of the first magnetic field being sinusoidally displaced and alternating each one-half period, each rotor **12** oscillates through an angle corresponding to approximately the peak amplitude of the sinusoid as the rotor **12** follows the stator magnets **68"**. Accordingly, a second difference between the third embodiment and the first embodiment is in the structure of the linkage **62**. In the third preferred embodiment, shown in **Fig.1C**, the linkage **62** comprises a reciprocating rod **91** connecting each rotor **12** to a respective first gear **87** rotationally attached to the armature **70**. The reciprocating rod **91** is pivotally mounted to each rotor **12** and to each first gear **87** so that the oscillating motion of the rotor **12** is converted to rotary motion of the first gear **87**. Each first gear **87** is coupled to a single second gear **89**, attached to the stator **50** in a fixed position. The rotary motion of each first gear **87** causes the armature **70** to rotate about the armature axis of rotation **58** as the rotors **12** oscillate about the rotor axis **16**. As will be appreciated by those skilled in the art, the speed of the motor **10** is fixed by the ratio of the first gear **87** to the second gear **89** in accordance with the expression:

$$S_a = (1 / N_s) \times S_r \dots\dots\dots (2)$$

Where:

S_s is the angular velocity of the armature **70** (RPM);

N_s is the number of first magnetic field periods around the stator **50"**; and

S_r is the angular velocity of the rotor **12** (RPM).

Because each rotor **12** oscillates instead of continually rotating, only a single rotor magnet. (or group of magnets) on a given rotor **12** interacts with the single stator **50"**. Accordingly, a third difference between the third preferred embodiment and the first preferred embodiment arises because of the oscillatory motion of each rotor **12** whereby each rotor **12** of the third preferred embodiment has only a single pair of magnets **32**. However, as will be appreciated by those skilled in the art, additional stators **50"** may be added around the periphery of the rotors **12** and additional pairs of U-shaped magnets **20** may be included on each rotor **12** to interact magnetically with each additional stator **50"**, thus providing additional motive power.

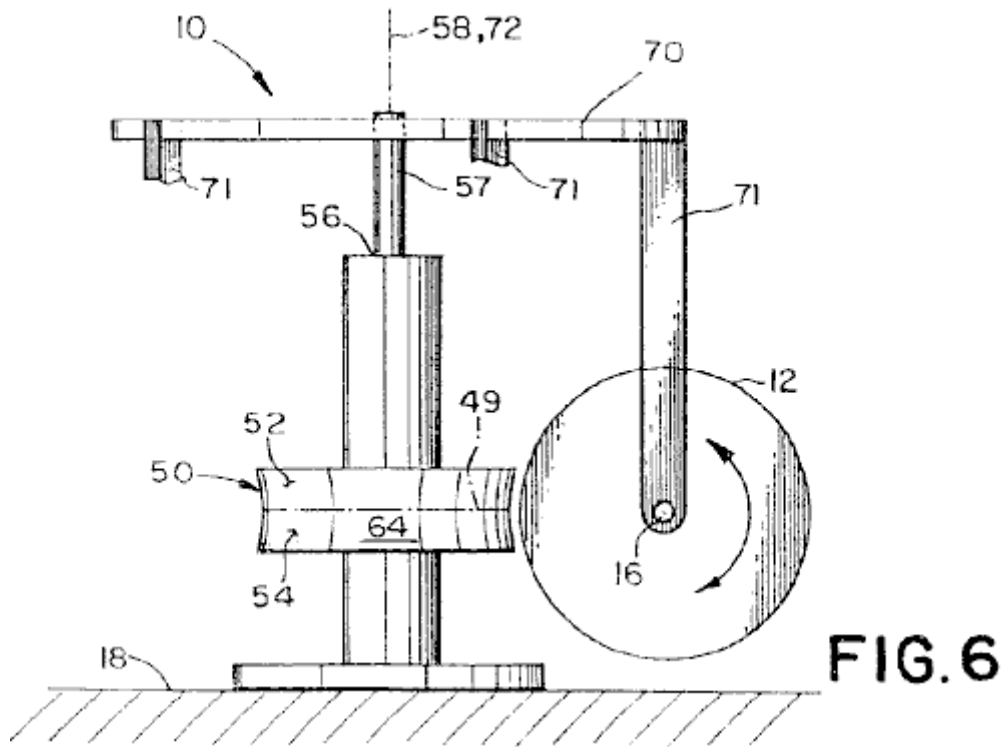

FIG. 6

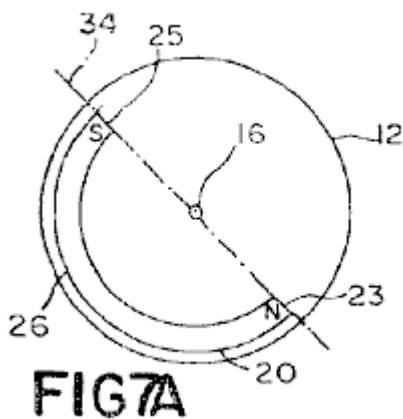

FIG. 7A

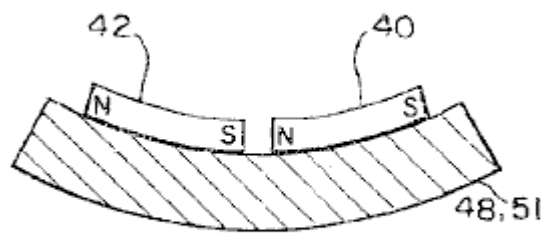

FIG. 8B

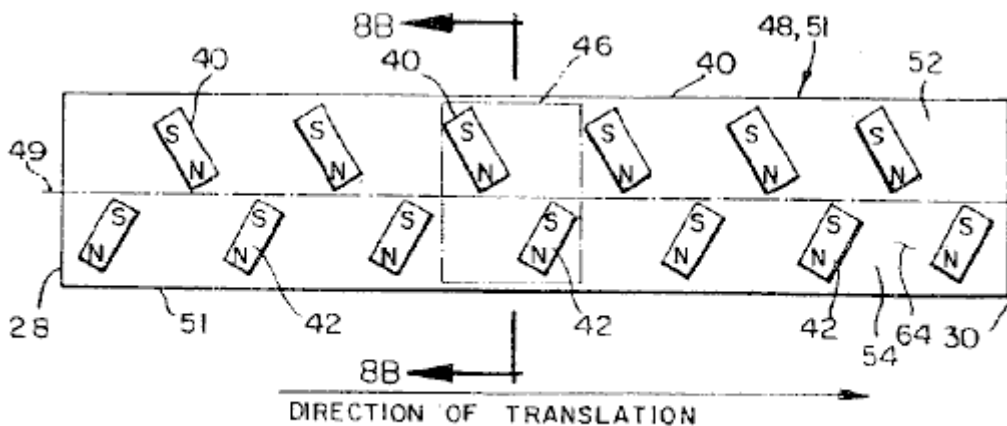

FIG. 8A

Referring now to **Figs. 6, 7A, 8A and 8B**, there is shown a fourth preferred embodiment of the permanent magnet motor **10** for providing unidirectional rotational motive power. The fourth preferred embodiment comprises a generally circular stator **51** having a stator axis **72**, attached to a base **18**. The stator **51** includes an outer surface **64** divided into a first side **52** and a second side **54** by a circumferential line of demarcation **49**, having a pre-determined direction around the stator axis **72**, at about a midpoint of the outer surface **64**.

Preferably, the surface **64** of the stator **51** is curved, having a curvature conforming to the arc of the rotors **12**. However, it will be appreciated by those skilled in the art that the surface **64** need not be curved but could be planar and still be within the spirit and scope of the invention. As will be appreciated by those skilled in the art the stator **51** is merely intended as a stationary supporting structure for stator magnets and, as such, the shape of the stator is not intended to be controlling of the size and shape of the air gap between the magnets attached to the stator and the magnets attached to the rotors.

As shown in **Fig.8A**, one or more pairs of stator magnets **46** are attached to the outer surface **64** spaced along the line of demarcation **49**. Each pair of stator magnets **46** comprises a first stator magnet **40** having a north pole and a south pole and a second stator magnet **42** having a north pole and a south pole. The south pole of each first stator magnet **40**, is located on the first side **52** of the outer surface **64**, and the north pole of the first stator magnet **40** is closest to the line of demarcation **49**. The north pole of each second stator magnet **42** is located on the second side **54** of the outer surface **64** and the south pole of each second stator magnet **42** being closest to the line of demarcation **49**. The first and the second stator magnets **40, 42** are spaced along the line of demarcation **49** so that a first inter-magnet distance measured along the line of demarcation **49** between the north pole of the first stator magnet **40** and the south pole of the second stator magnet **42** of an adjacent pair of magnets **46** is generally equal to a second inter-magnet distance measured along the line of demarcation **49'** between the south pole of the first stator magnet **40** and the north pole of the second stator magnet **42**.

In the fourth preferred embodiment, the stator magnets **40, 42** are bar magnets. Preferably, the north pole of each first stator magnet **40** and the south pole of each second stator magnet **42** are inclined toward the pre-determined direction. Also, the bar magnets are preferably oriented on the surface **64** of the stator **50** so that the south pole of each first magnet **40** and the north pole of each second magnet **42** are nearer to the periphery of each rotor **12** than the opposite polarity pole of each of the magnets **40, 42**. As will be appreciated by those skilled in the art, the stator magnets **40, 42** need not be bar magnets. For instance, each stator magnet **40, 42** could be a U-shaped magnet, or could be made up of separate magnets, as long as the first magnetic field generated by the magnets was generally equivalent to that produced by the bar magnets.

In the fourth preferred embodiment, an armature **70** having an armature axis of rotation **58** coincident with the stator axis **72** is attached to the stator **51** by an armature axle **57**, which armature axle **57** allowing the armature **70** to freely rotate about the stator axis **72**. Each rotor **12** is spaced from the armature **70** by an armature strut **71** and is mounted to the armature strut **71** so as to be free to rotate about the rotor axis **16**. The rotor axis **16** is oriented so that the rotor **12** rotates in a plane generally aligned with the armature axis of rotation **58**. In the fourth preferred embodiment, five rotors **12** are attached to the armature **70**. Preferably, the rotors **12** are uniformly spaced around the circumference of the stator **50** with a spacing of the rotors **12** as measured at the surface **64** of the stator **51** about equal to an integer multiple of twice the inter-magnet distance. However, as those skilled in the art will appreciate, it is not necessary to have the rotors **12** uniformly spaced. Further, the number of rotors **12** can be as few as one and as large as size and space constraints allow. As will be appreciated by those skilled in the art, the stator axis **72** need not be coincident with the armature axis of rotation **58**. Accordingly, a stator **50** arranged around the armature axis **58** at any location at which the stator axis **72** is parallel to the armature axis **58** and the surface of the stator **50** faces the periphery of the rotors **12**, thereby providing for the interaction between the first magnetic field and the second magnetic field around the armature axis **58**, is within the spirit and scope of the invention.

Referring now to **Fig.7A**, each rotor **12** comprises a first U-shaped magnet **20** generating a second magnetic field. The first U-shaped magnet **20** is positioned on the rotor **12** so that the north pole and the south pole of the first U-shaped magnet **20** faces toward the axis **16** of the rotor **12**, and the rear side **26** of the first U-shaped magnet **20** faces the periphery of the rotor **12**. When the rear **26** of the first U-shaped magnet **20** is adjacent to the north pole of one of the first stator magnets **40** along the line of demarcation **49**, a portion of the second magnetic field directly adjacent to the rear **26** of the first U-shaped magnet **20** interacts with a portion of the first magnetic field generated by the north pole of the first stator magnet **40** to cause the rotor **12** to rotate in a counterclockwise direction. As the rotor **12** rotates in the counterclockwise direction, a portion of the second magnetic field associated with the south pole of the first U-shaped magnet **20** interacts with a portion of the first magnetic field associated with the south pole of the first stator magnet **40**, giving rise to a force in the direction of the rotor axis **16**, repelling the U-shaped magnet **20**, and causing the rotor **12** to translate in the pre-determined direction around the stator axis. As the rotor **12** moves away from first stator magnet **40** in the pre-direction the second magnetic field adjacent to the rear **26** of the U-shaped magnet **20** interacts with the portion of the first magnetic field associated with the south pole of the second stator magnet **42** of the pair of magnets **46**, causing the rotor **12** to reverse direction and rotate in the clockwise direction. The portion of the second magnetic field associated with the north pole of the U-shaped magnet **20** then interacts with the portion of the first magnetic field associated with the north pole of the second stator magnet **42**, again giving rise to a force in the direction of the rotor axis **16**, repelling the U-shaped magnet **20** and causing the rotor **12** to translate in the pre-determined direction. An

oscillation cycle is then repeated with the second magnetic field of the rotor **12** interacting with the first magnetic field of the adjacent pair of magnets **46**. Accordingly, the rotor **12** rotationally oscillates about the respective rotor axis **16** and generates a force in the direction of the rotor axis **16**, causing the armature **70** to rotate in the pre-determined direction around the armature axis of rotation **58** to provide the unidirectional rotational motive power of the motor. As would be appreciated by those skilled in the art, the fourth embodiment is not limited to a single stator **51** and a single U-shaped magnet **20**. Additional stators having first and second stator magnets **40**, **42** arranged identically to the stator **51** to interact with corresponding U-shaped magnets spaced around the periphery of each rotor are within the spirit and scope of the invention.

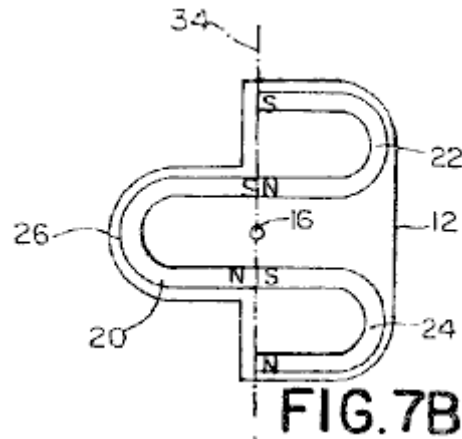

Referring now to **Fig.6**, **Fig.7B** and **Fig.8A** there is shown a fifth preferred embodiment of the permanent magnet motor **10** for providing unidirectional rotary motive force. The structure and operation of the fifth preferred embodiment is similar to that of the fourth preferred embodiment except that each rotor **12** further includes a second U-shaped magnet **24** having a north pole and a south pole with the south pole of the second U-shaped magnet **24** abutting the north pole of the first U-shaped magnet **20**, and a third U-shaped magnet **22** having a north pole and a south pole, with the north pole of the third U-shaped magnet **22** abutting the south pole of the first U-shaped magnet **20**. As the rotor **12** rotates due to interaction of the portion of the second magnetic field adjacent to the rear of the U-shaped magnet **20** with the first magnetic field, a third magnetic field generated by the north pole of the second U-shaped magnet **24** and a fourth magnetic field generated by the south pole of the third U-shaped magnet **22** each interact with the first magnetic field generated by each stator magnet pair **46** to cause each rotor **12** to generate a force in the direction of the rotor axis **16**, thereby causing the armature **70** to rotate in the pre-determined direction around the axis **58** of the stator **51** to provide the unidirectional rotational motive power of the motor.

In the fifth preferred embodiment, the portion of the second magnetic field adjacent to the rear **26** of the first U-shaped magnet **20** serves to rotate the rotor **12** while the second and third U-shaped magnets **24**, **22** generate the magnetic fields providing the force in the direction of the rotor axis **16**. Accordingly, the fifth preferred embodiment is potentially more powerful than the fourth preferred embodiment. As will be appreciated by those skilled in the art, the stator magnets **40**, **42** need not be bar magnets. For instance, each stator magnet **40**, **42** could be replaced by a U-shaped magnet or could be made up of separate magnets, as long as the first magnetic field generated by the magnets was generally equivalent to that produced by the bar magnets.

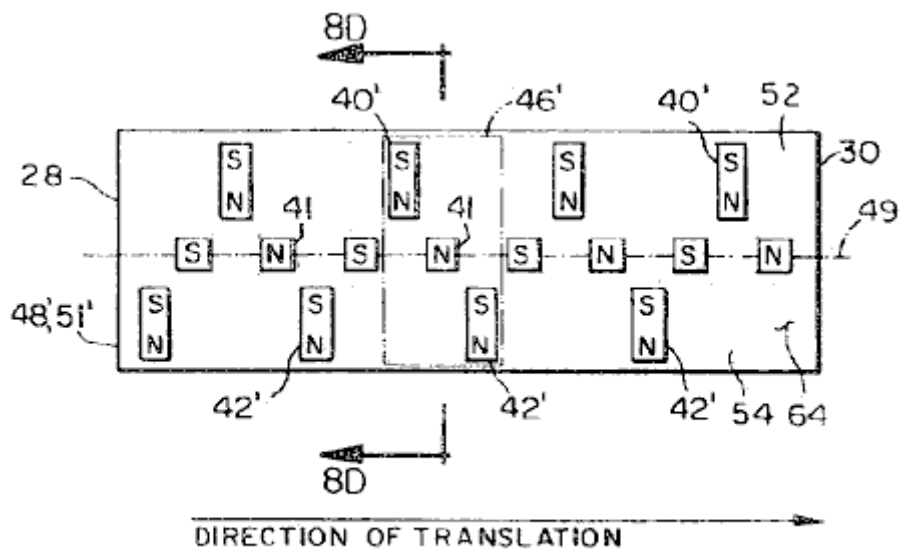
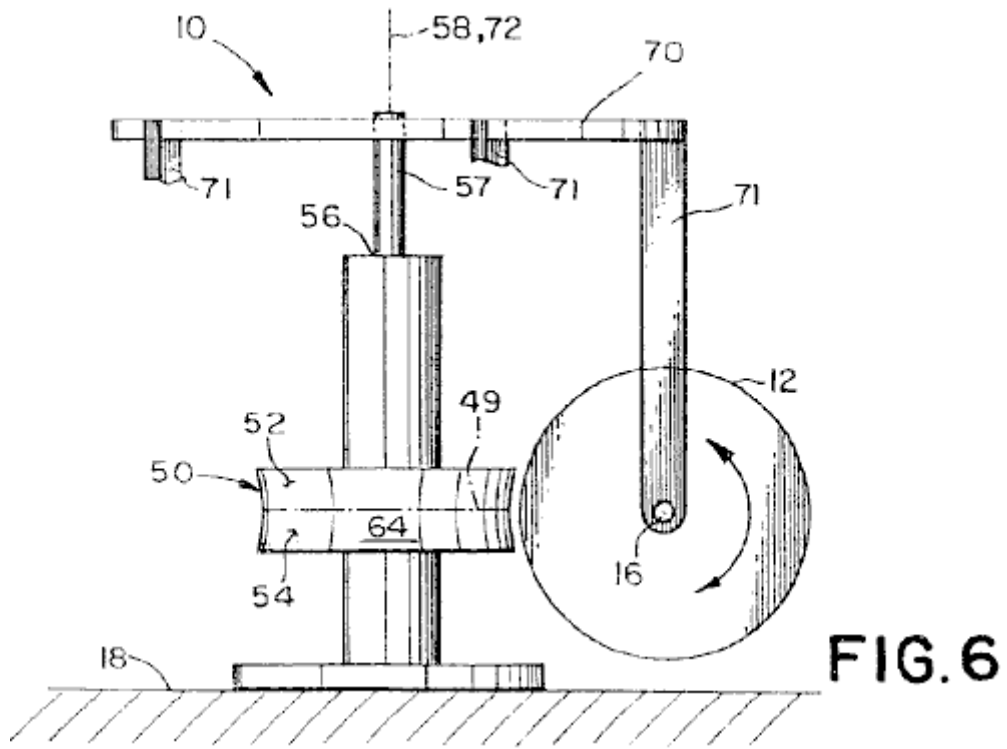

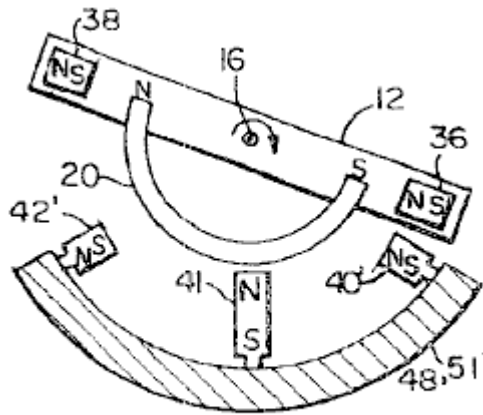

FIG. 8D

Referring now to **Fig.6** and **Fig.8C** and **Fig.8D** there is shown a sixth preferred embodiment of the motor **10**. The structure and operation of the sixth preferred embodiment is identical to that of the fifth preferred embodiment except that:

- (1) The stator magnets **40'**, **42'** on the surface **64** of the stator **51'** are in a slightly different orientation;
- (2) an additional stator magnet **41** is added to each pair of stator magnets **46** and
- (3) the U-shaped magnets **22**, **24** attached to each rotor **12** are replaced with bar magnets **36**, **38**.

Specifically, and referring now to **Fig.8C**, the direction of magnetisation of each first stator magnet **40'** and each second stator magnet **42'** is aligned to be generally perpendicular to the line of demarcation **49** instead of being inclined in the pre-determined direction around the armature axis of rotation **58** as in the fifth embodiment. Also, the stator **51'** also includes a third stator magnet **41** mounted on the outer surface **64** along the line of demarcation **49** mid-way between each first stator magnet **40'** and each second stator magnet **42'**. As shown in **Fig.8C** and **Fig.8D**, the third stator magnet **41** is oriented so that the direction of magnetisation of the third magnet **41** is aligned with the axis **16** of the rotors **12**.

As shown in **Fig.8C** and **Fig.8D**, the rotor **12** used in the sixth preferred embodiment includes a first U-shaped magnet **20**, similar to that of the fifth preferred embodiment. However, in place of the second and the third U-shaped magnets **24**, **22** used in the fifth preferred embodiments, the sixth preferred embodiment includes a first thruster bar magnet **36**, spaced from and proximate to the south pole of the first U-shaped magnet **20** and generally aligned with a thruster magnet axis **34**, and a second thruster bar magnet **38**, spaced from and proximate to the north pole of the first U-shaped magnet **20** and also generally aligned with the thruster magnet axis **34**. The thruster axis **34** lies in the plane of the rotor **12** and intersects the rotor axis **16**. Similar to the fifth preferred embodiment, the interaction of the portion of the second magnetic field directly adjacent to the rear of the U-shaped magnet **20** with the first magnetic field provides the rotational force for the rotors **12**. As the rotor **12** rotates in the clockwise direction (viewed from the second end **30** of the stator **51'**), a third magnetic field generated by both the north pole and the south pole of the second thruster magnet **36** interacts with the first stator magnet **40'**, again generating a force in the direction of the rotor axis **16**. Similarly, when the rotor **12** rotates in the counterclockwise direction a fourth magnetic field generated by both the north pole and the south pole of the first thruster magnet **38** interacts with second stator magnet **42'**, generating a force in the direction of the rotor axis **16**. The result of the force in the direction of the rotor axis **16** is to cause the armature **70** to rotate in the predetermined direction around the armature axis of rotation **58** to provide the unidirectional rotational motive power of the motor **10**.

In the sixth preferred embodiment, the stator magnets **40'**, **41**, **42'** and the thruster magnets **36**, **38** are bar magnets. However, as will be appreciated by those skilled in the art, the stator magnets **40'**, **41**, **42'** and the thruster magnets **36**, **38** need not be bar magnets. For instance, each stator magnet **40'**, **42'** could be a U-shaped magnet or could be made up of separate magnets, as long as the first magnetic field generated by the magnets was generally equivalent to that produced by the bar magnets.

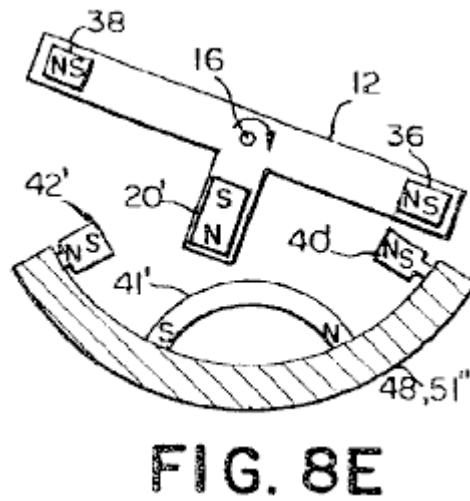
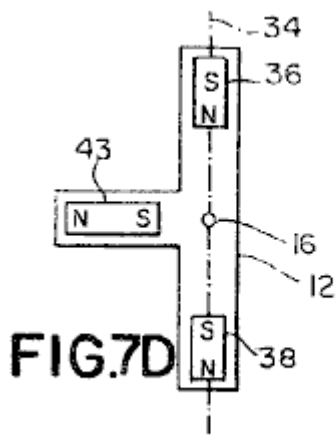

Referring now to **Fig.6**, **Fig.7D** and **Fig.8E** there is shown a seventh preferred embodiment of the motor **10**. The structure and operation of the seventh preferred embodiment is similar to the sixth preferred embodiment except that the third stator magnet **41'** located on the surface **64** of the stator **51''** along the line of demarcation **49** is a U-shaped magnet **41'** with the rear of the U-shaped magnet **41'** facing the rotor **12** and the direction of magnetisation being perpendicular to the line of demarcation **49**; and the U-shaped magnet **20** is replaced with a bar magnet **20'** oriented to have the direction of magnetisation aligned with a radial line of the rotor **12**. As in the sixth preferred embodiment, each stator magnet **40'**, **42'** could be a U-shaped magnet or could be made up of separate magnets, as long as the first magnetic field generated by the stator magnets **40'**, **42'** was generally equivalent to that produced by the bar magnets.

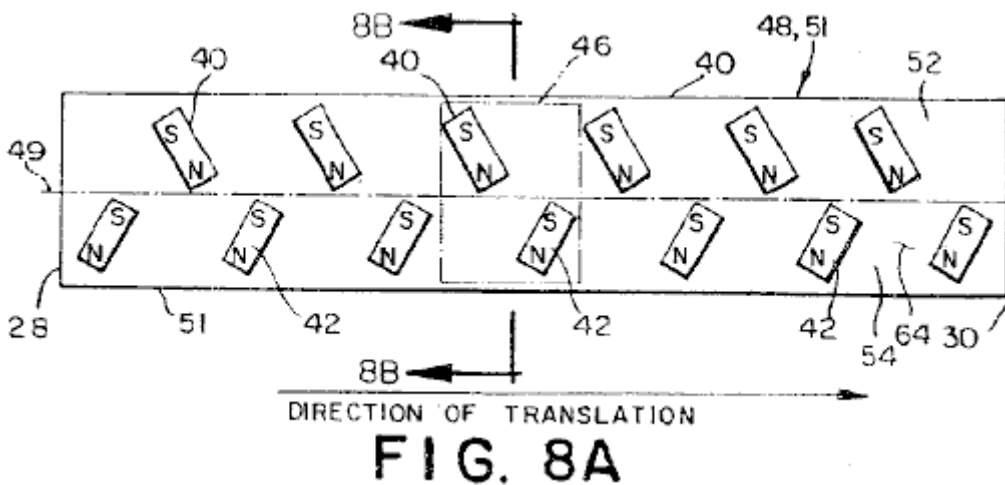
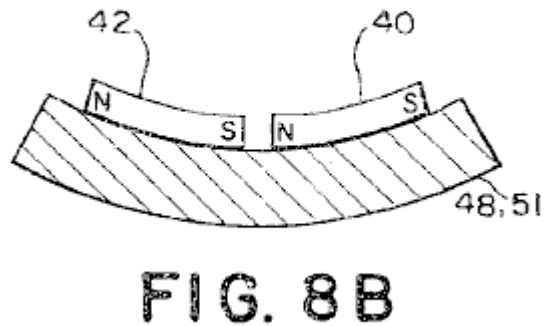
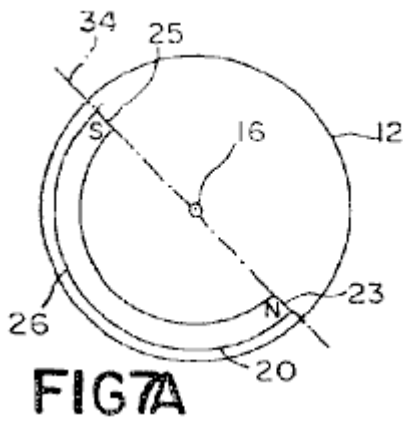

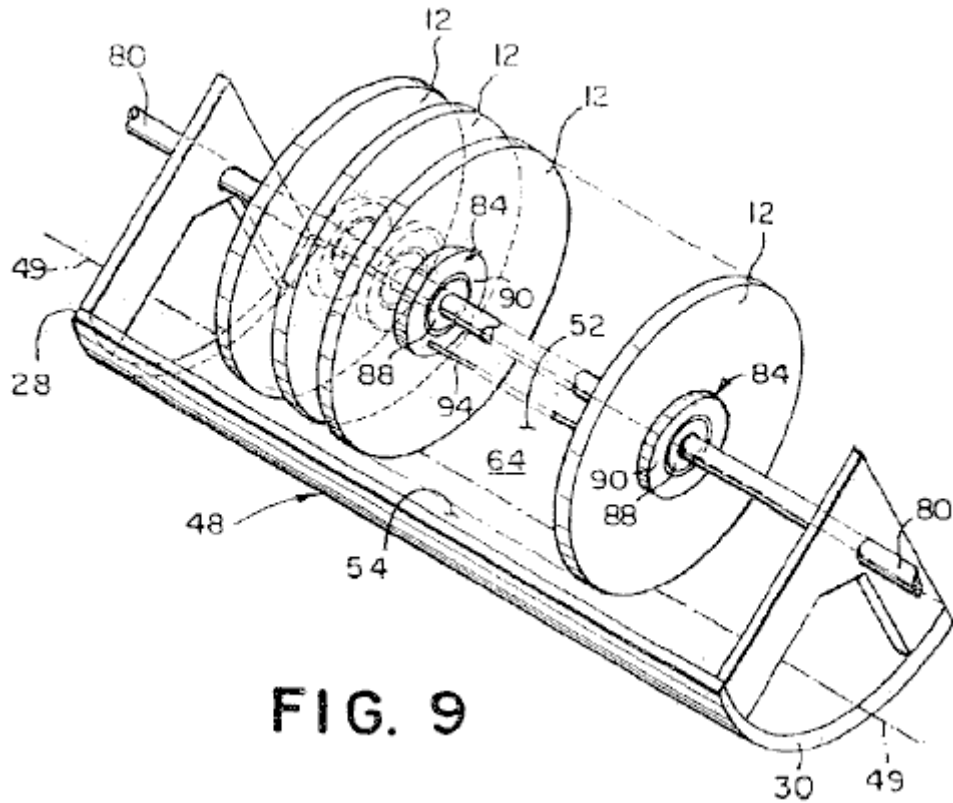

FIG. 9

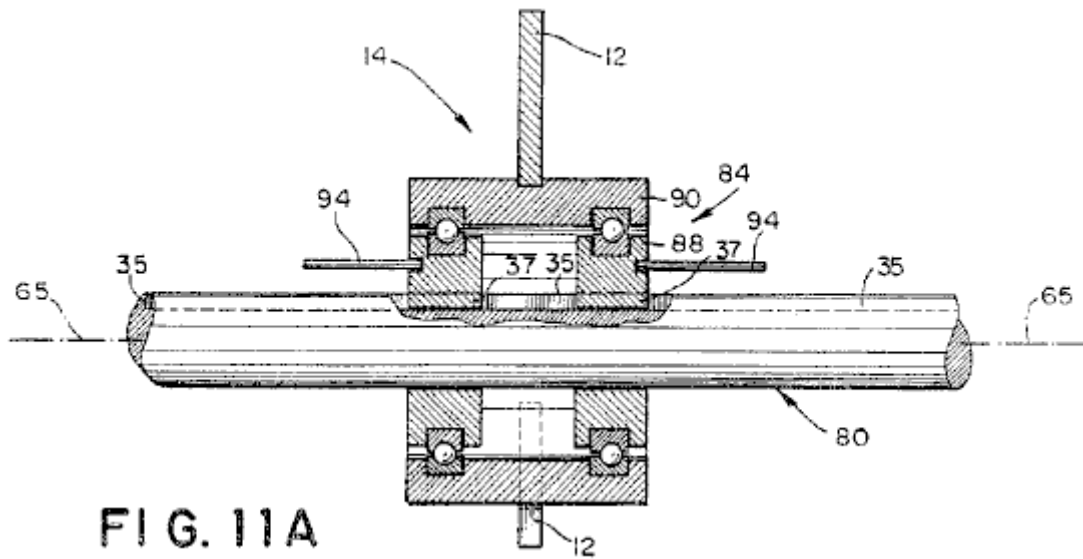

FIG. 11A

Referring now to **Fig.7A**, **Fig.8A**, **Fig.8B**, **Fig.9** and **Fig.11A**, there is shown an eighth preferred embodiment of the motor **10** for providing unidirectional linear motive power. The eighth preferred embodiment comprises a linear stator **48** having a generally curved cross-section perpendicular to a longitudinal line of demarcation **49** extending on a surface **64** of the stator between a first end **28** and a second end **30** and dividing the surface **64** of the stator **48** into a first side **52** and a second side **54**. Preferably, the generally curved cross-section of the stator **48** is concave. However, it will be appreciated by those skilled in the art that the cross-section need not be concave but could be planar or even convex and still be within the spirit and scope of the invention.

The linear stator **48** is identical to the generally circular stator **51** except for the surface **64** of the stator **48** being linear in the direction of the line of demarcation **49** instead of being circular in the direction of the line of demarcation **49**.

The eighth preferred embodiment includes the first and the second stator magnets **40**, **42** (see **Fig.8A**), the location and orientation of which are virtually identical to the orientation and location of the stator magnets **40**, **42** on the circular stator **51**. Accordingly, attached to the linear stator **48** is one or more pairs of magnets **46**, each pair of stator magnets **46** generating a first magnetic field and comprising a first stator magnet **40** having a north pole and a south pole and a second stator magnet **42** having a north pole and a south pole. The south pole of

each first stator magnet **40**, is located on the first side **52** of the outer surface **64**, with the north pole of the first stator magnet **40** being closest to the line of demarcation **49**. The north pole of each second stator magnet **42** is located on the second side **54** of the outer surface **64** with the south pole of each second stator magnet **42** being closest to the line of demarcation **49**. The first and the second stator magnets **40, 42** are spaced along the line of demarcation **49** so that a first inter-magnet distance measured along the line of demarcation **49** between the north pole of the first stator magnet **40** and the south pole of the second stator magnet **42** of an adjacent pair of magnets **46** is generally equal to a second inter-magnet distance measured along the line of demarcation **49** between the south pole of the first stator magnet **40** and the north pole of the second stator magnet **42**.

In the eighth preferred embodiment, the stator magnets **40, 42** are bar magnets, the north pole of each first stator magnet **40** and the south pole of each second stator magnet **42** being inclined toward the second end **30** of the linear stator **48**. Also, as shown in **Fig.8A**, the stator magnets **40, 42** are oriented on the surface **64** of the stator **51** so that the south pole of each first magnet **40** and the north pole of each second magnet **42** are nearer to the periphery of each rotor **12** than the opposite polarity pole of each of the stator magnets **40, 42**. As will be appreciated by those skilled in the art, the stator magnets **40, 42** need not be bar magnets. For instance, each stator magnet **40, 42** could be a U-shaped magnet or could be made up of separate magnets, as long as the first magnetic field generated by the magnets was generally equivalent to that produced by the bar magnets.

The eighth preferred embodiment also includes rail **80** having a longitudinal axis located generally parallel to the line of demarcation **49** of the stator **48**. Five rotor assemblies **14** comprising a rotor **12** and a bearing assembly **84** are slidably attached to the rail **80**.

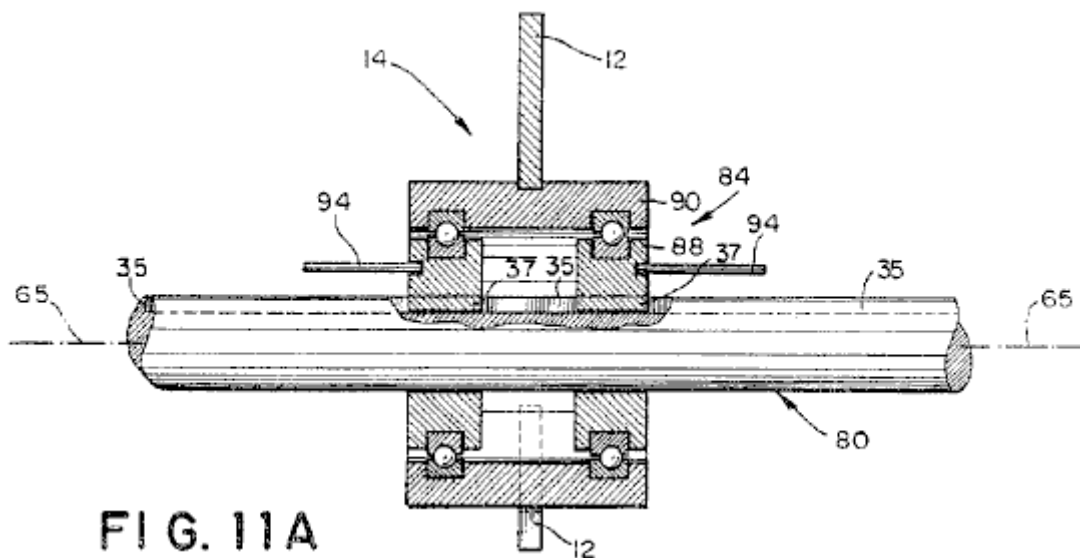

FIG. 11A

Preferably, the bearing assembly **84**, as shown in **Fig.11A**, includes a pair of first bearings **88** slidably mounted to the rail **80** and constrained to slide along the rail without any substantial rotation, by a boss **37** in each first bearing **88**, which is keyed to a longitudinal groove **35** on the rail **80**. A second bearing **90** is connected for rotation to the pair of first bearings **88** by ball bearings. The rotor **12** is attached to the second bearing **90**. Thus, the rotor **12** attached to each bearing assembly **84** is free to oscillate rotationally about the rail **80** and to generate a force along the rail **80** in the direction of the second end of the stator **30**.

Preferably, the eighth preferred embodiment includes a cross-link **94** which ties each bearing assembly **84** together by connecting together the first bearings **88** of each bearing assembly **84**, thereby adding together the linear motion along the rail **80** of each rotor **12**.

Preferably, each rotor **12** comprises one or more one rotor magnets **20**, each rotor magnet **20** generating a second magnetic field which interacts with the first magnetic field to cause the rotor **12** to oscillate rotationally about the axis of the rail **80** and to generate a force in the direction of the axis of the rail **80** to provide the unidirectional linear motive power of the motor. In the eighth preferred embodiment, each rotor **12** is substantially identical to the rotor **12** described for the fourth preferred embodiment. Accordingly, each rotor magnet comprises a first U-shaped magnet **20** having a north pole, a south pole and a rear side **26**, a first portion of the second magnetic field directly adjacent to the rear **26** of the U-shaped magnet **20** interacting with each first magnetic field to cause each rotor **12** to oscillate rotationally about the rail **80**. A second portion of the second magnetic field adjacent to the north and the south poles of the first U-shaped magnet **20** interacts with the first magnetic field to cause the rotor **12** to generate a force in the direction of the axis of the rail **80** thereby providing the unidirectional linear motive power of the motor. As would be clear to those skilled in the art, the operation of the eighth

preferred embodiment is identical to that of the fourth preferred embodiment except that the motion of the cross-linked rotors 12 is linear along the rail 80 instead of being rotational about the armature axis of rotation 58. Accordingly, for the sake of brevity, a description of the operation of the eighth preferred embodiment is not repeated.

Referring now to **Fig.7B, Fig.8A, Fig.8B, Fig.9** and **Fig.11A** there is shown a ninth preferred embodiment of the motor 10 for providing unidirectional linear motive power. As would be apparent to those skilled in the art, the structure and the operation of the ninth preferred embodiment is virtually identical to that of the fifth preferred embodiment except that the motion of the cross-linked rotors 12 is linear instead of rotational about the armature axis of rotation 58. Accordingly, for the sake of brevity, a description of the structure and the operation of the ninth preferred embodiment is not repeated.

Referring now to **Figs. 7C, 8C, 8D, 9** and **11A** there is shown a tenth preferred embodiment of the motor 10 for providing unidirectional linear motive power. As would be apparent to those skilled in the art, the structure and the operation of the tenth preferred embodiment is virtually identical to that of the sixth preferred embodiment except that the motion of the cross-linked rotors 12 is linear instead of rotational about the armature axis of rotation 58. Accordingly, for the sake of brevity, the operation of the tenth preferred embodiment is not repeated.

Referring now to **Figs. 7D, 8C, 8E, 9** and **11A** there is shown an eleventh preferred embodiment of the motor 10 for providing unidirectional linear motive power. The structure and operation of the eleventh preferred embodiment is virtually identical to the seventh preferred embodiment except that the motion of the cross-lined rotors 12 is linear instead of rotational about the armature axis of rotation 58. Accordingly, for the sake of brevity, the operation of the tenth preferred embodiment is not repeated.

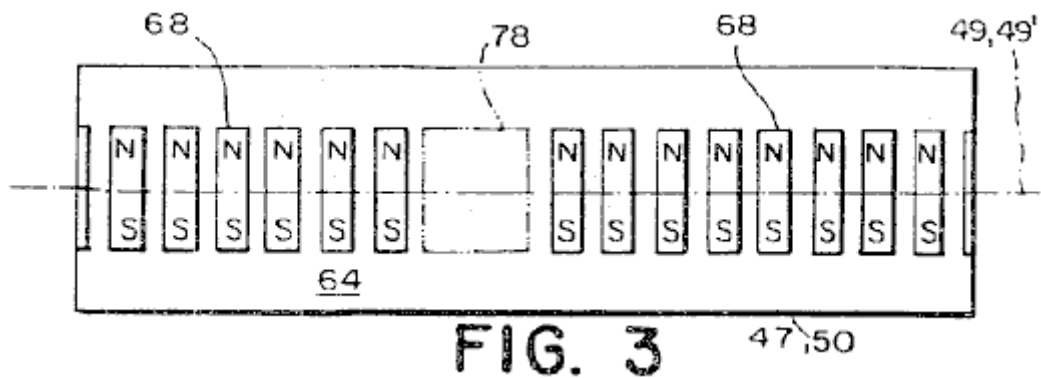
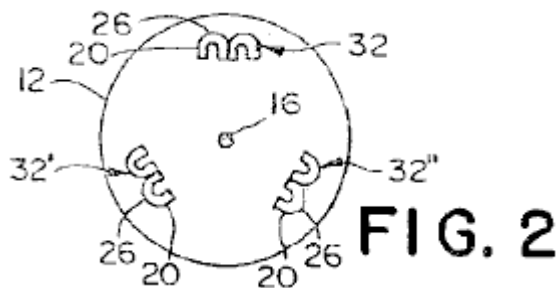

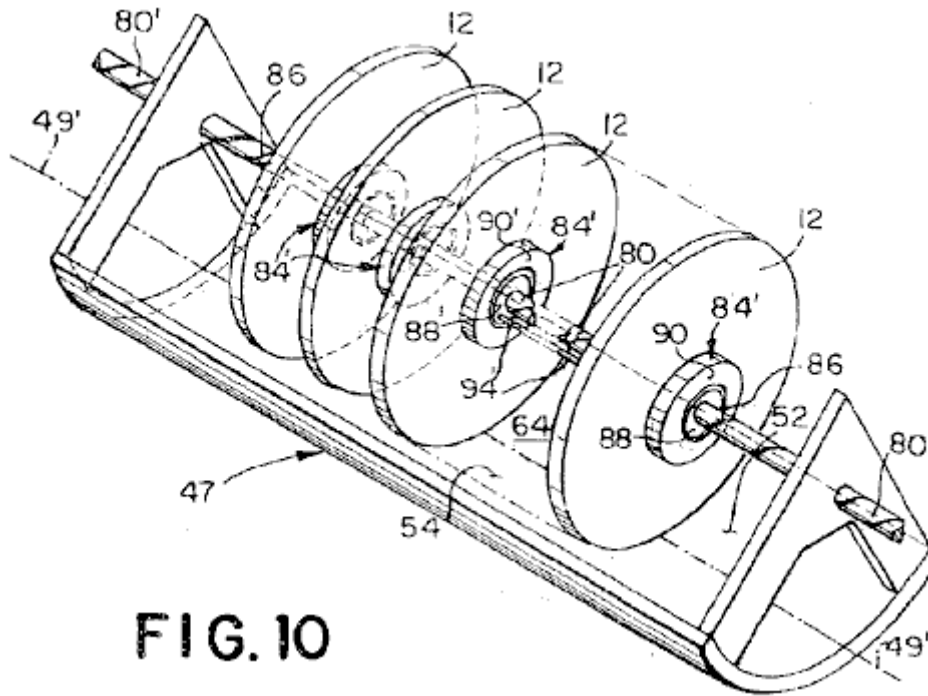
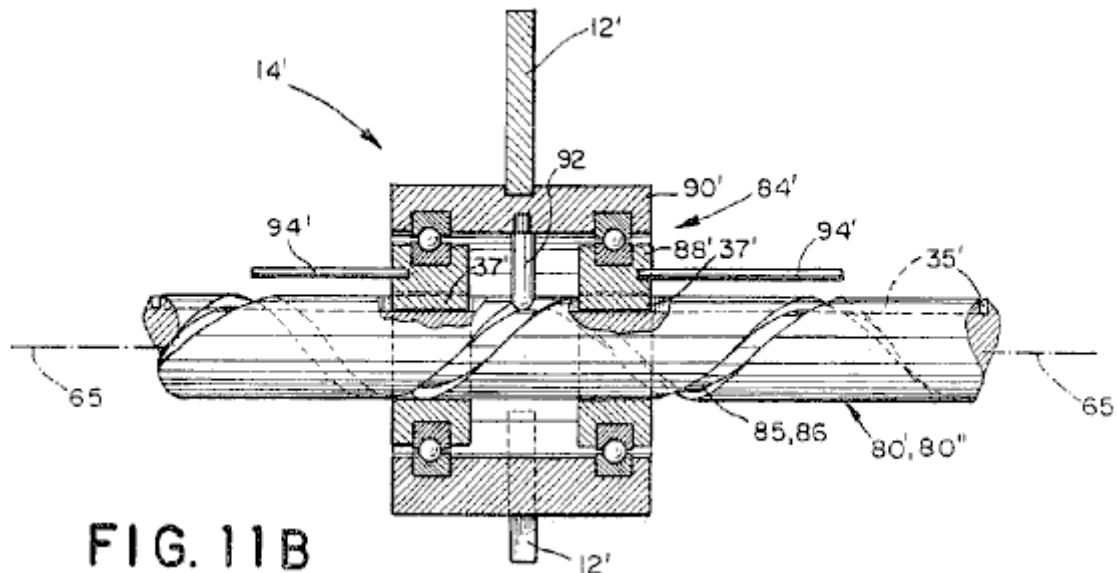

FIG. 10

Referring now to **Fig.2**, **Fig.3**, **Fig.10** and **Fig.11B**, there is shown a twelfth preferred embodiment of the motor **10** for providing linear motive power. As shown in **Fig.10**, the twelfth preferred embodiment comprises a linear stator **47** having a generally curved cross-section perpendicular to a line of demarcation **49'** extending along a midpoint of the stator **47** between a first end **28** and a second end **30** of the linear stator **47**, a rail **80'** connected to the linear stator **47** having an axis generally parallel to the line of demarcation **49'**, one or more rotor assemblies **14'** comprising rotors **12** connected to the rail **80'** by a bearing assembly **84'**, and a cross-link **94'** connecting together the linkages **84'** of adjacent rotors **12**. Preferably, the generally curved cross section of the stator **47** is concave, having a curvature conforming to the arc of the rotors **12**. However, it will be appreciated by those skilled in the art that the generally curved cross-section need not be concave but could be planar or even convex and still be within the spirit and scope of the invention.

As shown in **Fig.3**, the linear stator **47** includes one or more magnets **68** arranged on the surface **64** of the linear stator **47**, each magnet **68** having a direction of magnetisation directed at about a right angle to the line of demarcation **49'** and resulting in a first magnetic field directed generally at a right angle to the line of demarcation **49'**. The magnitude of the first magnetic field is generally uniform except in the null region **78**, in which the magnitude of the first magnetic field is substantially reduced. The linear stator **47** of the twelfth preferred embodiment is virtually identical to the circular stator **50** of the first preferred embodiment except the linear stator **50** is linear in the direction of the line of demarcation **49'** instead of being circular around the armature axis of rotation **58**. Also, the arrangement of the magnets **68** on the surface **64** of the stator **47** and the structure of the null region(s) **78** is the same as for the first preferred embodiment, as shown in **Fig.3** and as fully described in the discussion of the first embodiment. Accordingly, for the sake of brevity, a more detailed description of the structure of the linear stator **47** is not repeated.

The rotors **12** of the twelfth preferred embodiment each have an axis of rotation **16** which is aligned with an axis of the rail **80'**. The rotors **12** are connected to the rail **80'** by the bearing assembly **84'** so that each rotor **12** is free to rotate about the rail **80'** and to slide along the rail **80'**. Preferably, as shown in **Fig.2**, each rotor **12** includes three pairs of U-shaped magnets **32**, **32**, **32'**, each U-shaped magnet having a rear side **26** and generating a second magnetic field. A portion of the second magnetic field adjacent to the rear-side **26** of each U-shaped magnet **20** interacts with the first magnetic field to cause each rotor **12** to rotate about the axis of the rail **80**. The rotors **12** of the twelfth preferred embodiment are the same as the rotors in the first preferred embodiment, as described in **Fig.2** and fully discussed above. Accordingly, for the sake of brevity, the detailed description of the rotors **12** is not repeated.



As shown in **Fig.11B**, the rail **80'** has a helical groove **86** with a pre-determined pitch (i.e., turns/unit length) running around a periphery of the rail **80'**. The bearing assembly **84'** connects each rotor **12** to the helical groove **86**, converting the rotational motion of each rotor **12** around the rail **80'** to the linear motion along the rail **80'**. As shown in **Fig.11B**, the bearing assembly **84'** comprises a pair of first bearings **88'** mounted to the rail **80'** and constrained to slide along the rail **80'** without any substantial rotation, and a second bearing **90'**, mounted to an outer surface the first bearing **88'** for receiving the rotor **12**. Preferably, each first bearing **88'** has a boss **37** which engages a longitudinal groove **35** so that each first bearing **88'** slides on the rail **80'** without rotation as the second bearing **90'** rotates on the first bearings **88'**. It will be appreciated by those skilled in the art, other methods for securing the first bearings **88'** to the rail **80'** could be employed, as for instance, by making the cross-section of the rail **80'** oblate (flattened at the poles). As in the first preferred embodiment, each rotor **12** must rotate at a rate which results in the rear of each U-shaped magnet **20** on the rotor **12** passing through one of the null regions **78** each full rotation of the rotor **12**. Accordingly, the pre-determined pitch of the helical groove **86** on the rail **80'** preferably equals:

$$Pg = (1 / Nr) \times Pr \dots\dots\dots (3)$$

Where:

Pr = the pitch of the null regions **78** (null regions/unit length);

Nr = the number of U-shaped magnets (or groups of abutted U-shaped magnets) on a rotor **12**; and

Pg = the pitch of the helical groove **86** (revolutions/unit length).

Preferably, the portions of the helical groove **86** corresponding to each null region **78** have an instantaneous pitch which is greater than the pre-determined pitch of the groove **86** for increasing the angular velocity of the each rotor **12** as each one of the pairs **32, 32', 32''** of U-shaped magnets **20** passes through one of the null regions **78**. However, as will be appreciated by those skilled in the art, it is not necessary to provide the greater instantaneous pitch in order for the motor **10** to provide motive power.

As described above, the cross-link **94'** connects the bearing assembly **84'** of adjacent rotors **12** together. As shown in **Fig.10**, the cross-link **94'** connects the first bearings **88'** of each bearing assembly **84'** to the first bearing **88'** of the adjacent bearing assemblies **84'** so that the linear motion of all the rotor assemblies **14'** are added together to provide the unidirectional linear motive power of the motor **10**.

As previously stated, the first preferred embodiment of the motor **10** comprises a single null region **78** and five rotors **12**, each rotor **12** having three pairs **32, 32', 32''** of abutted U-shaped magnets **20**. Preferably, the rotors **12** are uniformly spaced along the rail **80'** and the pairs **32, 32', 32''** of U-shaped magnets **20** are uniformly spaced around the periphery of each respective rotor **12**. Further, the pairs **32, 32', 32''** of U-shaped magnets **20** are phased with respect to each rotor **12** by one-fifth of a revolution of the rotor **12** so that the pairs **32, 32', 32''** of U-shaped magnets **20** of all the rotors **12** pass through the null region **78** at a substantially uniform rate to provide a more or less continuous interaction between the first magnetic field and the second magnetic field of the rotors **12**, resulting in a more or less continuous urging of the rotor assemblies **14'** toward the second end of the stator **47**. As will be appreciated by those skilled in the art, the motive power provided by the motor **10** is proportional to the number of rotors **12** and the number of U-shaped magnets **20** on each rotor **12**. Accordingly, the number of rotors **12** and the number of pairs **32, 32', 32''** of magnets **20** of the present invention are not limited to five rotors

12 and three pairs 32 of U-shaped magnets 20. Neither is the number of null regions limited to one. The number of U-shaped magnets 20 and null regions 78 are limited only by adherence to the rule established by Equation 3.

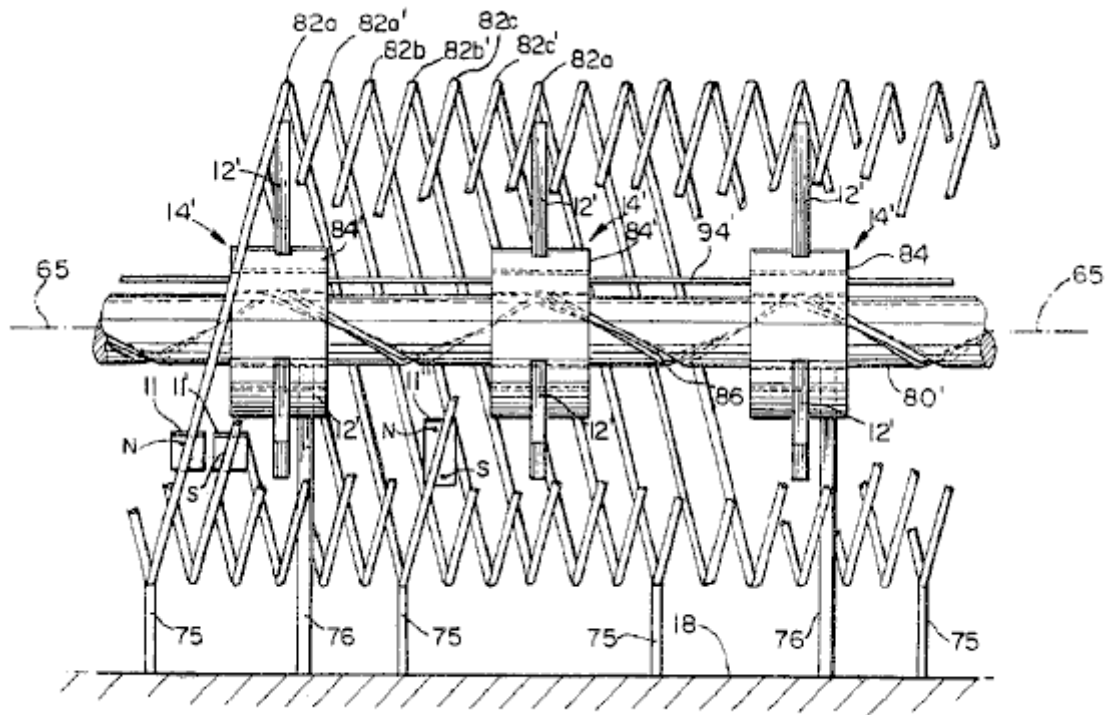
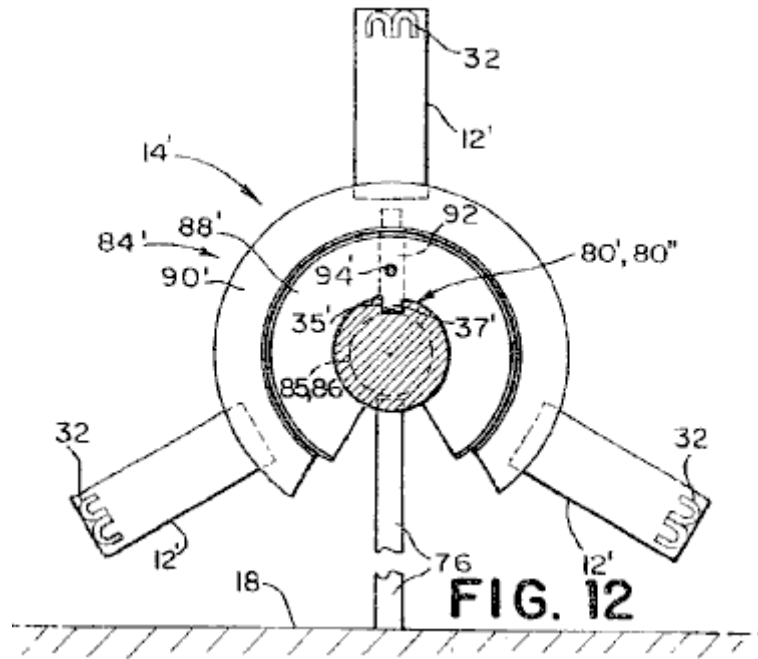

FIG. 13

Referring now to Fig.2, Fig.11B, Fig.12 and Fig.13 there is shown a thirteenth preferred embodiment of the motor 10 comprising a rail 80' supported by rail mounting posts 76 and having a longitudinal axis 65. A helical groove 86 having a pre-determined pitch runs around a periphery of the rail 80'.

The thirteenth preferred embodiment also includes three first helical stators 82a, 82b, 82c (82) concentrically surrounding the rail 80' corresponding to three pairs 32, 32' 32'' of U-shaped magnets 20 mounted on each of five rotors 12. Preferably, the first helical stators 82 have the same pitch as the pre-determined pitch of the groove 86 and a longitudinal axis generally parallel to the axis 65 of the rail 80'. A plurality of first stator magnets 11 having a direction of magnetisation aligned with a radial line of each rotor 12 are spaced along each first helical stator 82 with the first stator magnets 11 generating a first magnetic field.

The thirteenth preferred embodiment further includes plurality of second helical stators **82a', 82b', 82c'** (**82'**) alternating with the first helical stators **82'** along the axis **65** of the rail **80'**, and having the pre-determined pitch of the groove **86**. Each second helical stator **82'** has mounted upon it a plurality of second stator magnets **11'** having a direction of magnetisation aligned with a radial line of the rotor **12** and having a direction of magnetisation opposite in direction to the first stator magnets **11** mounted on each of the first helical stators **82**. As a consequence of the second helical stators **82'** being located midway between the first helical stators **82**, a point at about a midpoint between each rotor magnet pair **32, 32', 32''** is apposite to one of the second helical stators **82'** as each rotor **12** rotates about the axis **65** of the rail **80'** and slides along the rail **80'**.

The thirteenth preferred embodiment also includes five rotors **12**, (for clarity, only three are shown), having an axis of rotation **16** generally aligned with the longitudinal axis **65** of the rail **80'**. Each rotor **12** is connected to the rail **80'** by a bearing assembly **84'** so that the rotor **12** is free to rotate about the axis **65** of the rail **80'** and slide along the rail **80'**. Preferably, each rotor **12** includes three pairs **32, 32', 32''** of U-shaped magnets **20** wherein each U-shaped magnet **20** generates a second magnetic field, a portion of which adjacent to a rear **26** of the pair of U-shaped magnets **20** interacts with the first magnetic field of each first stator magnet to cause each rotor **12** to rotate about the axis **65** of the rail **80'**.

The bearing assembly **84'** (shown in detail in **Fig.11B** and **Fig.12**) connects each rotor **12** to the helical groove **86** around the periphery of the rail **80**. The bearing assembly **84'** is similar to the bearing assembly **84'** described in the twelfth preferred embodiment except for the openings in the first bearings **88'** and in the second bearing **90'** which allow the bearing assembly **84'** past the rail mounting posts **76** as the bearing assembly **84'** moves along the rail **80'**.

The thirteenth preferred embodiment may be constructed as either a linear motor or a rotary motor. In the case of the linear motor, the axes of the rail **80'** and of each helical stator **82** are substantially straight. The rail **80'** is supported on the base **18** by rail mounting posts **76** placed at intervals along the rail **80'**. The posts **76** are situated at locations along the rail **80'** at which the rotation of the rotor **12** orients the openings in the first and second bearings **88', 90'** to correspond to the mounting posts **76**. Each helical stator **82a, 82b, 82c** is supported on the base by stator mounting posts **75**. The rotors **12** are connected together by a cross-link **94'** which connects the first bearings **88'** of each bearing assembly **84'** to the first bearing **88'** of the bearing assembly **84'** of an adjacent rotor **12**. In this manner, the rotational motion of each rotor assembly **14'** is added together to provide the linear motive power of the linear motor.

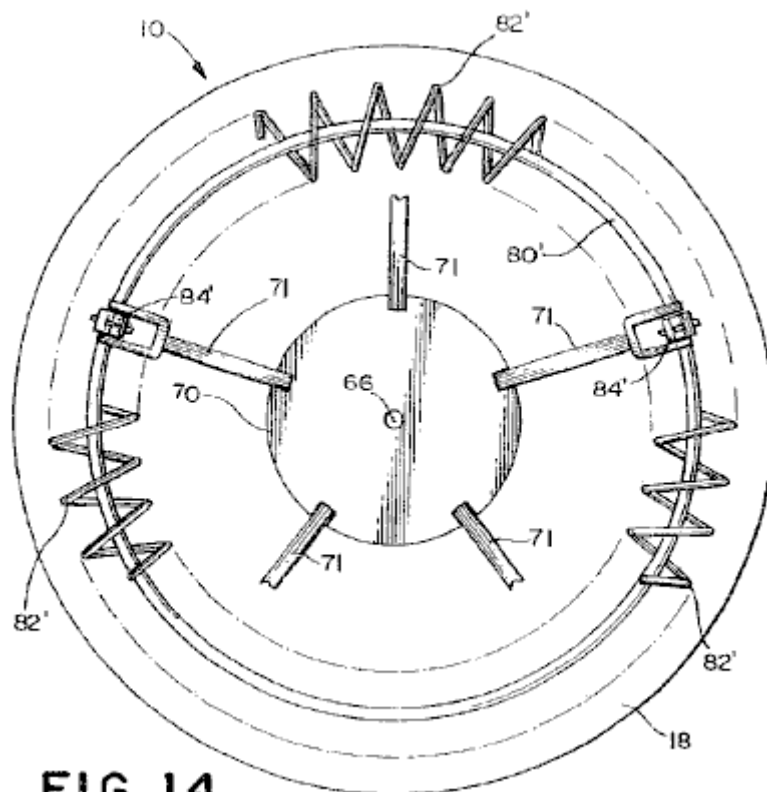

The thirteenth preferred embodiment may also be constructed as a rotary motor **10** as shown in **Fig.14**. In this case, the axes of the rail **80'** and the helical stators **82** are configured to be circular. The circularly configured motor **10** includes an armature **70** centrally located within the perimeter of the rail **80'**. The armature **70** rotates

about an armature axis of rotation 58 connected for rotation within a motor base 18 to which the rail 80' is also attached by mounting posts 76 (not shown). The pitch of the first and the second helical stators 82, 82', measured at a radius of the rail 80, preferably equals the predetermined pitch of the helical groove 86. The armature 70 is fixedly attached to the first bearing 88 (see Fig.11B) of each bearing assembly 84' by an armature strut 71 thereby adding together the rotational motive power of each rotor assembly 14. In order that the armature strut 71 does not interfere with the first and second helical stators 82, 82', the first and second helical stators 82, 82' are made to have an opening toward the armature axis of rotation 58.

Preferably, each first helical stator 82a, 82b, 82c has mounted upon it a plurality of first stator magnets 11 with each stator magnet 11 having a direction of magnetisation aligned with a radial line of the rotor 12. Preferably, the first helical stators 82 are uniformly spaced along the longitudinal axis 65 of the rail 80' with each first helical stator 82 corresponding to one of the plurality of magnet pairs 32, 32', 32". Preferably, each rotor 12 is positioned on the rail 80' so that one of the rotor magnet pairs 32, 32', 32" is apposite to one of the corresponding first helical stators 82 as the rotor 12 rotates about the axis 65 of the rail 80 and slides along the rail 80'. However, as those skilled in the art will appreciate, the rotor magnet pairs 32, 32', 32" need not be directly apposite to each helical stator 82 as the rotors 12 rotate in order to generate a rotational force.

Alternatively, as will be appreciated by those skilled in the art, the motor 10 can be constructed without the second helical stator 82'. In the simplest case the motor 10 could comprise only a single first helical stator 82 and a single rotor 12 comprising a single U-shaped magnet 20 generating the second magnetic field. The single rotor 12 is preferably positioned in the groove 86 on the rail 80' so that the U-shaped rotor magnet 20 is continually apposite to the single first helical stator 82. Consequently, a portion of the second magnetic field directly adjacent to a rear 26 of the U-shaped magnet 20 interacts with the first magnetic field generated by each first stator magnet 11" mounted on the helical stator 82 to cause the rotor 12 to rotate about the axis 65 of the rail 80 and to slide along the rail 80'. Preferably, when only a single first stator 82 set of first stators 82 is used, each first stator magnet 11" has a direction of magnetisation oriented to be in the plane of the rotor 12 and generally perpendicular to a radial line of the rotor 12. The north pole and the south pole of the first stator magnet 11" are preferably spaced apart so that when one pole of the first stator magnet 11 is directly apposite to the rotor magnet 20, the pole of opposite polarity is equally spaced from the U-shaped magnet 20 of the rotor 12. As one skilled in the art would appreciate, a plurality of U-shaped rotor magnets 20 and corresponding first helical stators could be used. Further, as those skilled in the art will appreciate, other configurations of the rotor magnet 20 and the stator magnet 11 are possible, all of which rely on the novel attributes of the magnetic field adjacent to the rear 26 of a U-shaped rotor magnet 20. For example, the previously described stator magnet 11" perpendicular to the radial line of the rotor 12 could be two separate bar magnets, spaced apart, with the magnetisation of each of the two magnets aligned with a radial line of the rotor and having opposite directions of magnetisation.

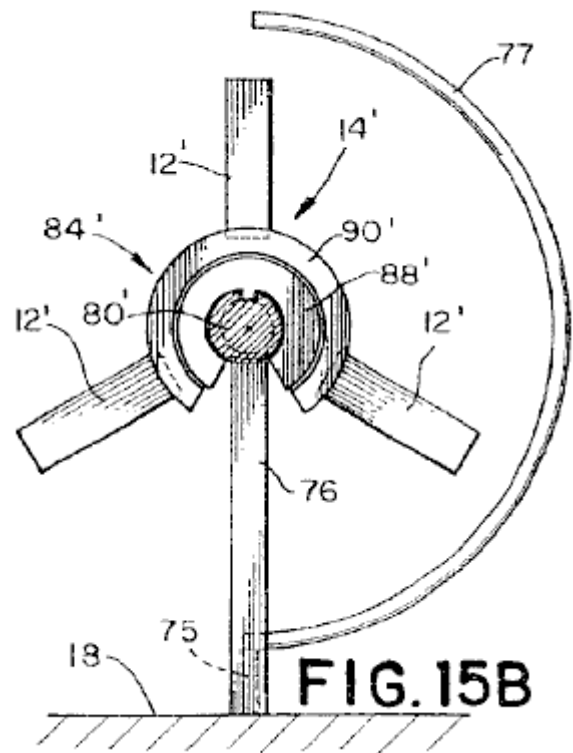
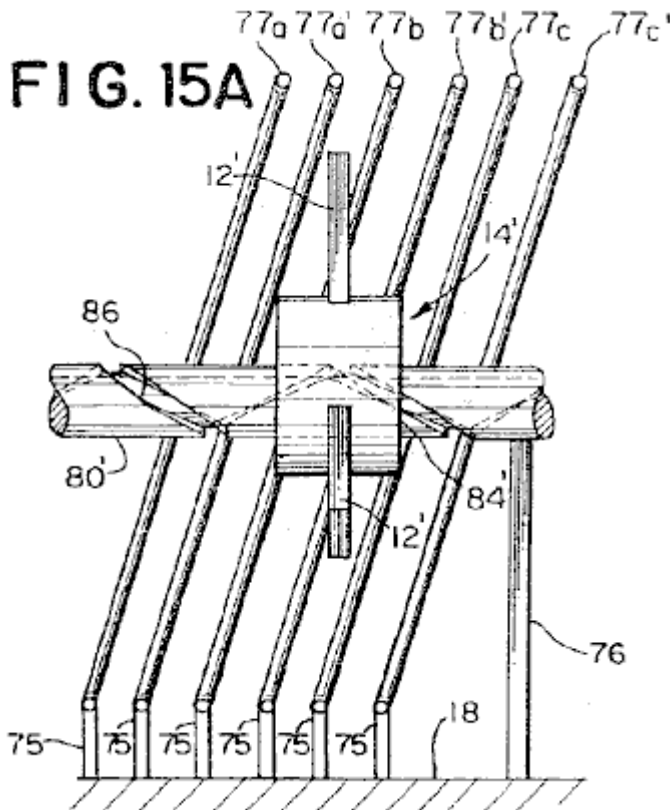

Referring now to **Fig.15A** and **Fig.15B** there is shown a fourteenth preferred embodiment of the motor **10**. The fourteenth embodiment is identical in structure to the thirteenth preferred embodiment except that the stator comprises a plurality of first ribs **77a, 77b, 77c (77)** and second ribs **77a', 77b', 77c' (77')** in place of the first and the second helical stators **82, 82'** of the thirteenth embodiment. By substituting ribs **77, 77'** for the helical stators **82, 82'**, the attachment of the armature **70** to the rotors **12** is simplified. As those skilled in the art will appreciate, the length of the ribs **77, 77'** may vary from as little as 45 degrees to up to 265 degrees, with the motive power of the motor **10** being proportional to the length of the ribs.

Preferably, the first and the second ribs **77, 77'** have a pitch and a spacing that conforms to the pre-determined pitch of the rail **80'**. Further the orientation of the first and second stator magnets **11, 11'** and of the U-shaped rotor magnets **20** would be identical to the thirteenth embodiment. Accordingly, the operation of the fourteenth embodiment is identical to that of the thirteenth embodiment and is not repeated here for the sake of brevity.

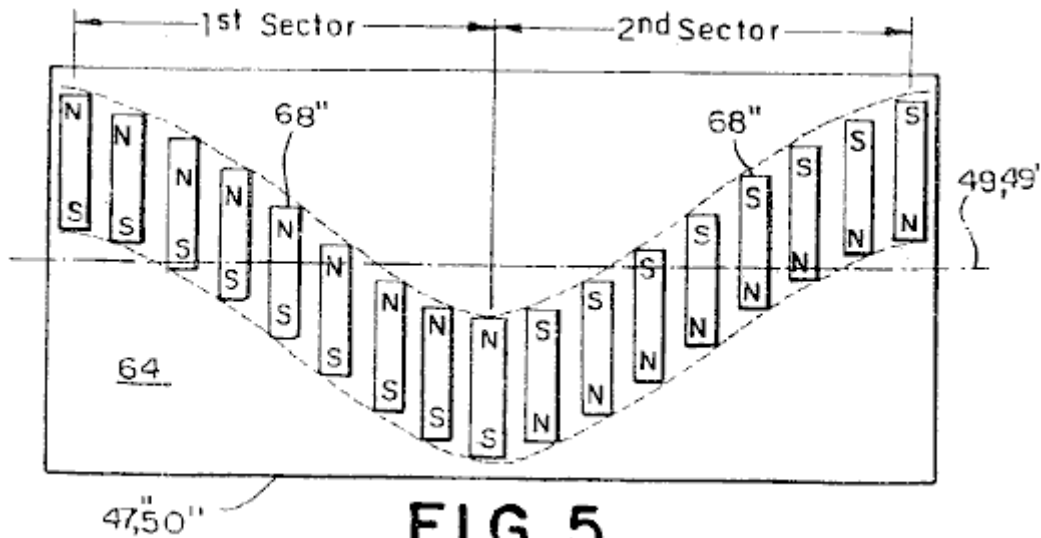

FIG. 5

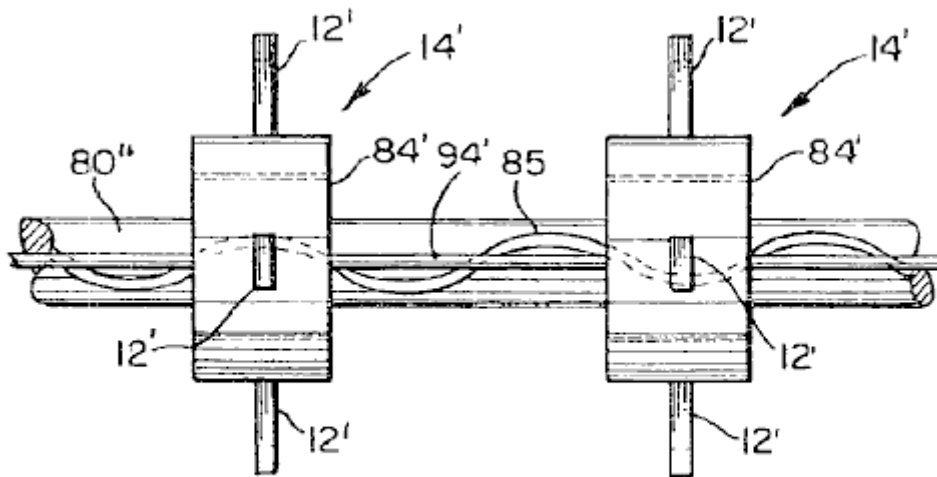

FIG. 16

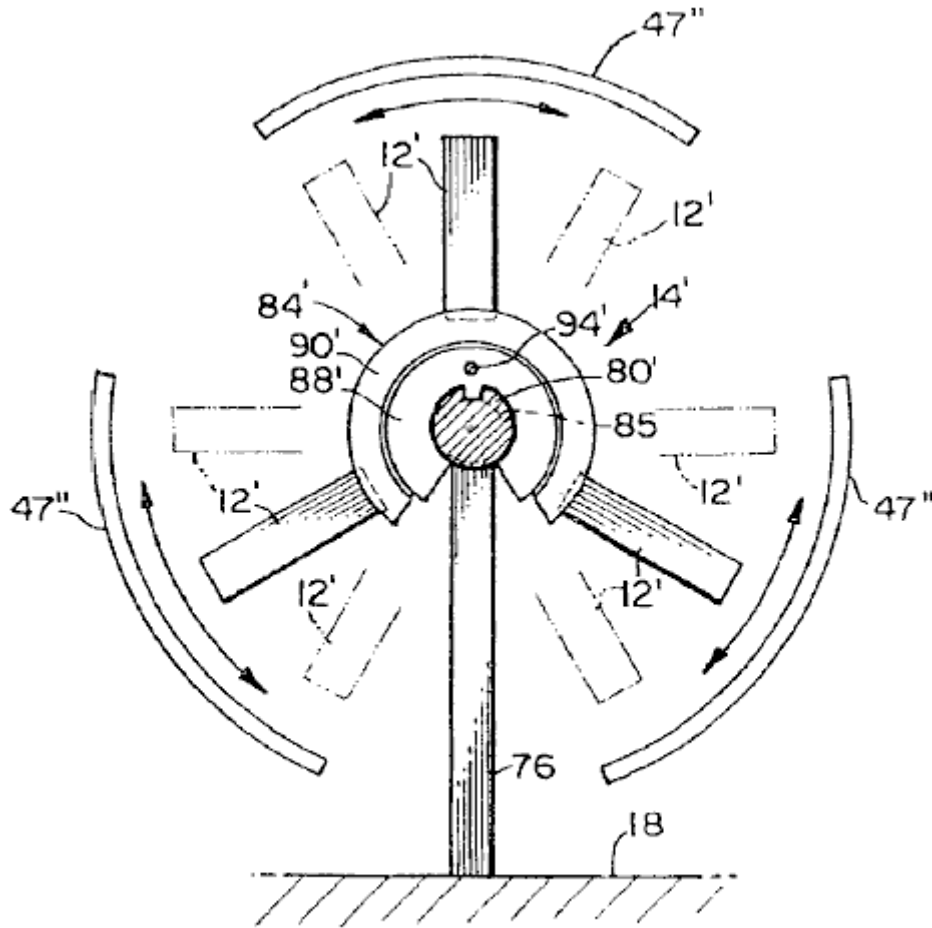

FIG. 17

Referring now to **Fig.5**, **Fig.16** and **Fig.17** there is shown a fifteenth preferred embodiment of the motor **10** comprising a rail **80''** having a longitudinal axis **65** and a generally sinusoidal groove **85** having a pre-determined period running around a periphery of the rail **80''**.

Preferably, the fifteenth preferred embodiment includes three generally identical stators **50''** arrayed in a circular fashion around the rail **80''**. Each stator **50''** has a surface **64** facing the rail **80''** and disposed generally equidistant from and parallel to the axis **65** of the rail **80''**. As shown in **Fig.5** and **Fig.17** each stator **50''** has a generally curved cross-section and a longitudinal line of demarcation **49** perpendicular to the cross-section and located about a midpoint of the surface **64**.

A plurality of stator magnets **68''** are attached to the surface **64** of the stator **50''** generating a first magnetic field. The stator magnets **68''** are displaced on the surface **64** in a sinusoidal pattern around the line of demarcation **49**. The sinusoidal pattern has a pre-determined period and a pre-determined maximum (peak) amplitude along the line of demarcation **49**. In the case where the rail **80''** and the longitudinal line of demarcation **49** of the stator **50''** are in a straight line, the period of the sinusoid is preferably equal to the period of the groove **85** on the rail **80**.

The sinusoidal pattern is also divided into a plurality of first and second alternating sectors with a boundary between the alternating sectors occurring at each maximum (peak) amplitude of the sinusoid. The direction of magnetisation of the stator magnets **68''** is opposite in the first and the second segments so that the direction of the first magnetic field in each first segment is opposite to the direction of the first magnetic field in each second segment. Preferably, the direction of magnetisation of the stator magnets **68''** is generally perpendicular to a radial line of the rotor **12**. Alternatively, the direction of magnetisation of the stator magnets **68''** could be generally aligned with a radial line of the rotor **12**. Further, as will be apparent to those skilled in the art, the first magnetic field need not be formed by a plurality of bar magnets but could be formed from a single magnet so that the first magnetic field would be sinusoidally displaced from the line of demarcation **49** and would alternate in opposite directions between the peaks of the sinusoid. Further, as will be appreciated by those skilled in the art, the displacement of the first magnetic field need not be precisely sinusoidal. For instance the displacement may be in a shape of a sawtooth or in a shape having a portion with constant plus and minus amplitude values, within the spirit and scope of the invention.

Preferably, the fifteenth preferred embodiment includes five rotors **12**, each rotor **12** having an axis **16** aligned with the axis of the rail **80''**. Each rotor **12** is connected to the rail **80''** by a bearing assembly **84'** so that the rotor **12** is free to rotate about the axis of the rail **65** and slide along the rail **80''**. Preferably, each rotor **12** includes three U-shaped magnet pairs **32, 32', 32''**, each pair comprising two U-shaped magnets **20**. Each U-shaped magnet **20** has a rear side and generates a second magnetic field. Each of the U-shaped magnet pairs **32, 32', 32''** is positioned on each rotor **12** so that the rear side **26** of each U-shaped magnet **20** is apposite to the first and the second segments of the sinusoidal pattern as the at least one rotor assembly **14** rotates about the rotor axis **16**, wherein an interaction of a portion of the second magnetic field directly adjacent to the rear **26** of each U-shaped magnet **20** with the first magnetic field of a corresponding stator **50''** causes the at least one rotor **12** to oscillate rotationally about the axis **65** of the rail **80''**. Those skilled in the art will appreciate that it is not necessary to have three pairs of U-shaped magnets **32, 32', 32''**. For instance, the number of U-shaped magnets **20** (or groups of abutted U-shaped magnets) spaced apart around the periphery of the rotor **12** may range from merely a single U-shaped magnet **20**, or may range in number up to a number of magnets limited only by the physical space around the periphery of the rotor **12**. Further the number of abutted U-shaped magnets **20** in a group of magnets **32** may also range from 1 up to a number of magnets limited only by the physical space around the periphery of the rotor **12**. Preferably, the number of stators **50''** equals the number of U-shaped magnet pairs **32, 32', 32''**. However, as will be appreciated by those skilled in the art, the number of stators **50''** is not limited to three but could be any number ranging upward from one, where the number of stators **50''** would preferably equal the number of U-shaped magnet pairs **32, 32', 32''**.

As shown in **Fig.16** the bearing assembly **84'** converts the oscillatory motion of the at least one rotor **12** about the rail to unidirectional linear motion along the rail **80'** by following the sinusoidal groove **85** in the rail **80'** with the boss **92** (shown in **Fig.11B**). A cross-link **94** connects the bearing assembly **84'** of adjacent rotors **12** together, thereby adding together the linear motion of each rotor assembly **14'** along the rail to provide the unidirectional linear motive power. The structure of the bearing assembly **84'** and the cross-link **94** is shown in **Fig.11B** and **Fig.12**, and the operation is identical to the linkage **84'** and the cross-link **94'** described for the twelfth embodiment. Accordingly, a detailed description of the linkage **84'** and the cross-link **94** is not repeated, for the sake of brevity.

In another aspect, the fifteenth preferred embodiment may also be configured in a circular arrangement similar to that of the fourteenth embodiment. In the fifteenth preferred embodiment, the helical stator **82'** shown in **Fig.14** is replaced with one or more curved stators **50''** spaced around the rotors **12**. In this case, the period of the sinusoidal pattern of the stator magnets is adjusted in accordance with the distance of the surface **64** of the respective stator **50''** from the armature axis of rotation **58** in order that the U-shaped magnets **20** on the rotors **12** remain apposite to the first and the second segments, as the rotors **12** slide along the rail **80''**. Accordingly, a description of those elements of circular arrangement of the fifteenth embodiment which are the same as for the linear embodiment are not repeated, for the sake of brevity.

Referring now to **Fig.4, Fig.18** and **Fig.19** there is shown a sixteenth preferred embodiment of the motor **10** for providing unidirectional motive power comprising a rail **80''** having a longitudinal axis **65** and a helical groove **86** having a pre-determined pitch, running around a periphery of the rail **80**.

Preferably, the sixteenth preferred embodiment further includes three generally identical stators **50'**, each stator **50'** having a surface **64** disposed generally equidistant from and parallel to the axis **65** of the rail **80**. Each stator **50'** has a longitudinal line of demarcation **49** located about a midpoint of the surface **64**. Preferably, a plurality of stator magnets **68'** are attached to the surface of the stator **50'** generating a first magnetic field. The plurality of stator magnets **68'** have a direction of magnetisation which rotates about a magnetic axis parallel to the line of demarcation **49**. In the case where the rail **80''** and the longitudinal line of demarcation **49** of the stator **50'** are in a straight line, the pitch of the rotation of the stator magnets **68'** is preferably equal to the pre-determined pitch of the helical groove **86** on the rail **80**.

The sixteenth embodiment further includes five rotors **12**, each rotor **12** having an axis of rotation **16** aligned with the axis **65** of the rail **80**. Each rotor **12** is connected to the rail **80** so that the rotor **12** is free to rotate about the axis **65** of the rail **80** and slide along the rail **80**. Each rotor **12** includes three pairs **32, 32', 32''** of U-shaped magnets **20** spaced around the periphery of the rotor **12**, each U-shaped magnet **20** generating a second magnetic field. The U-shaped magnets **20** are positioned on each rotor **12** so that a portion of the second magnetic field directly adjacent to the rear side **26** of the U-shaped magnet **20** interacts with the first magnetic field generated by the plurality of stator magnets **68'** to cause each rotor **12** to rotate about the rotor axis **16**. Those skilled in the art will appreciate that it is not necessary to have exactly three pairs of U-shaped magnets **32, 32', 32''**. For instance, the number of U-shaped magnets **20** (or groups of abutted U-shaped magnets) spaced apart around the periphery of the rotor **12** may range from merely a single U-shaped magnet **20**, or may range in number up to a number of U shaped magnets **20** limited only by the physical space around the periphery of the

rotor 12. Further the number of abutted U-shaped magnets 20 in a group of magnets 32 may also range from 1 up to a number of magnets limited only by the physical space around the periphery of the rotor 12.

The sixteenth embodiment also includes a bearing assembly 84' connecting each rotor 12 to the helical groove 86, the bearing assembly 84' converting the rotary motion of each rotor 12 about the rail 80' to unidirectional linear motion along the rail 80'. A cross-link 94 connects the bearing assembly 84' of adjacent rotors 12 together, thereby adding together the linear motion of each rotor assembly 14' along the rail 80' to provide the unidirectional linear motive power. The structure of the bearing assembly 84' and the cross-link 94 is shown in Fig.11B and Fig.12, is identical to the bearing assembly 84' and cross-link 94 described for the twelfth embodiment. Accordingly, a description of the linkage 84 and the cross-link 94 is not repeated, for the sake of brevity.

In another aspect of the sixteenth preferred embodiment the motor 10 may be configured in a circular arrangement similar to that of the fourteenth embodiment, as shown in Fig.14, except that the helical stator 82' shown in Fig.14 is replaced with one or more stators 50' spaced around the rotors 12. In this case, the pitch of the rotation of the plurality of stator magnets 68' is adjusted in accordance with the distance of the surface 64 of the respective stator 50' from the armature axis of rotation 58 in order that the U-shaped magnets 20 on the rotors 12 remain aligned with the plurality of stator magnets 68' as the rotors 12 rotate about the axis 65 of the rail 80' and slide along the rail 80'. Accordingly, a description of those elements of the circular arrangement of the sixteenth embodiment which are the same as for the straight line configuration are not repeated, for the sake of brevity.

It will be appreciated by those skilled in the art that changes could be made to the embodiments described above without departing from the broad inventive concept thereof. It is understood, therefore, that this invention is not limited to the particular embodiments disclosed, but it is intended to cover modifications within the spirit and scope of the present invention as defined by the appended claims.

CLAIMS

1. An apparatus (10, 10') characterised by:

at least one rotor (12) having a periphery and a rotor axis (16), the at least one rotor (12) comprising a first rotor magnet (20) producing a first magnetic field, said first rotor magnet being U-shaped and having a north pole (23), a south pole (25) and a rear side (26), the rear side (26) of the first rotor magnet being adjacent to the periphery;

an axle (80) to which the at least one rotor (12) is connected at the rotor axis (16) for rotation of the at least one rotor (12) about the rotor axis (16); and

a stationary stator (48, 51) comprising a generally curved cross-section, said stator (51) having a surface (64) opposing the periphery of the at least one rotor (12), and a longitudinal line of demarcation (49) perpendicular to the cross-section at about a midpoint of the surface, the line of demarcation (49) delineating a first side (52) of the surface from a second side (54) of the surface (64), wherein a plurality of pairs of stator magnets (40, 42) producing a second magnetic field are attached to the surface (64), each pair of stator magnets (40, 42) comprising a first stator magnet (40) having a north pole and a south pole and a direction of magnetisation substantially parallel to the surface (64), and a second stator magnet (42) having a north pole and a south pole and a direction of magnetisation substantially parallel to the surface (64), the first stator magnet (40) being on the first side of the surface (64) with the north pole of the first stator magnet being closest to the line of demarcation (49), the second stator magnet (42) being on the second side (52) of the surface with the south pole of the second stator magnet (42) being closest to the line of demarcation (49), wherein the plurality of pairs of stator magnets (40, 42) are spaced along the line of demarcation (49) so that a first inter-magnet distance measured along the line of demarcation (49) between the north pole of the first stator magnet (40) and the south pole of the second stator (42) magnet of an adjacent pair of stator magnets (40, 42) is about equal to a second inter-magnet distance measured along the line of demarcation between the south pole of the first stator magnet (40) and the north pole of the second stator magnet (42), and wherein the interaction of the first and the second magnetic fields cause the at least one rotor (12) to translate in a predetermined direction along the line of demarcation.

2. The apparatus (10, 10') of claim 1, characterised by the north pole of each first stator magnet (40) and the south pole of each second stator magnet (42) being inclined toward the predetermined direction.

3. The apparatus (10, 10') of claim 1, further characterised by the rotor (12) including a second rotor magnet (22), said second rotor magnet (24) being U-shaped and having a north pole, a south pole and a rear side, the south pole of the second rotor magnet (22) abutting the north pole of the first rotor magnet (26) and the north pole of the second rotor magnet being adjacent to the periphery, and a third rotor magnet (24), said third rotor

magnet (24) having a north pole, a south pole and a rear side, the north pole of the third rotor magnet (24) abutting the south pole of the first rotor magnet (26) and the south pole of the third rotor magnet (24) being adjacent to the periphery, said second magnet producing a third magnetic field and third magnet producing a fourth magnetic field.

4. The apparatus (10) of claim 1, characterised by the apparatus further including an armature (70) having an armature axis (58), the at least one rotor (12) being spaced from the armature (70) by an armature strut (71) and connected thereto by the axle (80) for rotation about the rotor axis (16), the at least one rotor (12) configured for rotation in a plane generally aligned with the armature axis (58), wherein the stator (51) is circular-cylindrical, with a stator axis (72) aligned with the armature axis (58).
5. The apparatus (10') of claim 1, further characterised by the stator (48) being linear, the stator (48) oriented so that the surface (64) of the stator (48) is generally parallel to the axle (80), each at least one rotor (12) being connected to the axle (80) by a bearing assembly (84) comprising a pair of first bearings (88) slidably attached to the axle (80), and a second bearing (90) connected to the pair of first bearings (88) for rotation about the first pair of bearings (88), said at least one rotor (12) being fixedly attached to the second bearing (90).
6. The apparatus (10') of claim 5, further characterised by a crosslink (94) which connects together the at least one rotors (12).
7. A apparatus (10, 10') characterised by:

at least one rotor (12) having a periphery, a rotor axis (16) and a thruster axis (34) perpendicular to the rotor axis (16) and intersecting the rotor axis (16), the at least one rotor (12) comprising spaced apart first and second rotor magnets (36, 38) having north and south poles aligned with the thruster axis (34), and a third rotor magnet (20, 20') located between the first and second rotor magnets (34, 38) on an axis generally perpendicular to the thruster axis (34), said first, second and third magnets producing a first magnetic field;

an axle (80) to which the at least one rotor (12) is connected at the rotor axis (16) for rotation of the at least one rotor (12) about the rotor axis (16); and

a stationary stator (48', 51') comprising a generally curved cross-section, said stator (48', 51') having a surface 64 opposing the periphery of the at least one rotor (12), and a longitudinal line of demarcation (49) perpendicular to the cross-section at about a midpoint of the surface (64), the line of demarcation (49) delineating a first side (52) of the surface from a second side (54) of the surface, wherein a plurality of sets of stator magnets (40', 42', 41) producing a second magnetic field are attached to the surface (64), each set of stator magnets (40', 42', 41) comprising a first stator magnet (40') having a north pole and a south pole and a direction of magnetisation substantially perpendicular to the surface (64), a second stator magnet (42') having a north pole and a south pole and a direction of magnetisation substantially perpendicular to the surface (64), and a third stator magnet (41), the third stator magnet (41) being attached to the stator (48', 51') along the line of demarcation (49) midway between the first stator magnet (40') and the second stator magnet (42'), the first stator magnet (40') being on the first side (52) of the surface with the south pole of the first stator magnet (40') being closest surface (64), the second stator magnet (42') being on the second side (54) of the surface (64) with the north pole of the second stator magnet (42') being closest to the surface (64), wherein the plurality of sets of stator magnets (40', 42', 41) are spaced along the line of demarcation (49) so that a first inter-magnet distance measured along the line of demarcation (49) between the north pole of the first stator magnet (40') and the south pole of the second stator magnet (42') of an adjacent pair of stator magnets (40', 42', 41) is about equal to a second inter-magnet distance measured along the line of demarcation (49) between the south pole of the first stator magnet (40') and the north pole of the second stator magnet (42'), wherein the interaction of the first and the second magnetic fields cause the at least one rotor (12) to translate in a predetermined direction along the line of demarcation.

8. The apparatus (10, 10') of claim 7, characterised by the third rotor magnet (20) being a U-shaped magnet and the third stator magnet (41) being a bar magnet.
9. The apparatus (10, 10') of claim 7, characterised by the third rotor magnet (20') being a bar magnet and the third stator magnet (41') being a U-shaped magnet.
10. The apparatus (10) of claim 7, characterised by the apparatus further including an armature (70) having an armature axis (58), the at least one rotor (12) being spaced from the armature (70) by an armature strut (71) and connected thereto by the axle (80) for rotation about the rotor axis (16), the at least one rotor (12) being configured for rotation in a plane generally aligned with the armature axis (58), wherein the stator (51') is circular, with a stator axis (72) aligned with the armature axis (58).

11. The apparatus (10') of claim 7, further characterised by the stator (48') being linear, the stator (48') oriented so that the surface (64) of the stator (48') is generally parallel to the axle (80), each at least one rotor (12) being connected to the axle (80) by a bearing assembly (84) comprising a pair of first bearings (88) slidably attached to the axle (80), and a second bearing (90) connected to the pair of first bearings (88) for rotation about the pair of first bearings (88), said at least one rotor (12) being fixedly attached to the second bearing (90).
12. The apparatus (10') of claim 11, further characterised by a crosslink (94) which connects together the at least one rotors (12).
13. An apparatus (10) for providing motion characterised by:
 - a stationary, generally circular, stator (50, 50', 50'') having a stator axis (58), an outer surface (64), and a circumferential line of demarcation (49) in a plane perpendicular to the stator axis (58) at about a midpoint of the outer surface (64);
 - at least one stator magnet (68, 68', 68'') attached to the outer surface (64) of the stator (50, 50', 50''), the at least one stator magnet (68, 68', 68'') being arranged in a generally circular arrangement about the stator axis (58);
 - an armature (70) attached to the stator (50, 50', 50'') for rotation therewith, the armature (70) having an axis parallel to the stator axis (58);
 - at least one rotor (12) including at least one rotor magnet (20), the at least one rotor (12) being spaced from the armature (70) by an armature strut (71) and connected thereto by an axle (80) for rotation about a rotor axis (16), the at least one rotor (12) being configured for rotation in a plane generally aligned with the stator axis (58); and
 - a driving linkage assembly (53, 55, 62) connecting the at least one rotor to the stator, the linkage assembly (53, 55, 62) configured to cause the armature (70) to rotate about the stator axis (58) when the at least one rotor (12) rotates about the rotor axis (16).
14. The apparatus according to claim 13 wherein a direction of magnetisation of the at least one stator magnet (68) is generally perpendicular to a radial line of the at least one rotor (12).
15. The apparatus according to claim 13 wherein a direction of magnetisation of the at least one stator magnet (68) is generally aligned with a radial line of the at least one rotor (12).
16. The apparatus according to claim 13 wherein the at least one rotor magnet (20) comprises a U-shaped magnet.
17. The apparatus according to claim 13 wherein the at least one rotor magnet (20) comprises a bar magnet and the at least one stator magnet (68) is a U-shaped magnet.
18. The apparatus according to claim 13, the at least one stator magnet (68') having a direction of magnetisation which rotates about the circumferential line of demarcation (49) with a predetermined periodicity.
19. The apparatus according to claim 13, the at least one stator magnet (68'') having a direction of magnetisation in a plane of the stator (50'') and which is displaced in a sinusoidal pattern from the line of demarcation (49), the sinusoidal pattern having a pre-determined period and a pre-determined maximum amplitude and divided into a plurality of alternating first and second sectors with a boundary between the alternating first and second sectors occurring at peak amplitudes of the sinusoid, the direction of magnetisation of the at least one magnet (68'') being opposite in direction in the first and the second segments.

PERMANENT MAGNET MOTOR



This is a re-worded extract from this Patent. It describes a motor powered solely by permanent magnets and which it is claimed can power an electrical generator.

ABSTRACT

The invention is directed to the method of utilising the unpaired electron spins in ferromagnetic and other materials as a source of magnetic fields for producing power without any electron flow as occurs in normal conductors, and to permanent magnet motors for utilising this method to produce a power source. In the practice of the invention the unpaired electron spins occurring within permanent magnets are utilised to produce a motive power source solely through the superconducting characteristics of a permanent magnet, and the magnetic flux created by the magnets is controlled and concentrated to orientate the magnetic forces generated in such a manner to produce useful continuous work, such as the displacement of a rotor with respect to a stator. The timing and orientation of magnetic forces at the rotor and stator components produced by the permanent magnets is accomplished by the proper geometrical relationship of these components.

BACKGROUND OF THE INVENTION:

Conventional electric motors employ magnetic forces to produce either rotational or linear motion. Electric motors operate on the principal that when a conductor which carries a current is located in a magnetic field, a magnetic force is exerted upon it. Normally, in a conventional electric motor, the rotor, or stator, or both, are so wired that magnetic fields created by electromagnets use attraction, repulsion, or both types of magnetic forces, to impose a force upon the armature causing rotation, or linear displacement of the armature. Conventional electric motors may employ permanent magnets either in the armature or stator components, but to date they require the creation of an electromagnetic field to act upon the permanent magnets. Also, switching gear is needed to control the energising of the electromagnets and the orientation of the magnetic fields producing the motive power.

It is my belief that the full potential of magnetic forces existing in permanent magnets has not been recognised or utilised because of incomplete information and theory with respect to atomic motion occurring within a permanent magnet. It is my belief that a presently unnamed atomic particle is associated with the electron movement of a superconducting electromagnet and the loss-less flow of currents in permanent magnets. The unpaired electron flow is similar in both situations. This small particle is believed to be opposite in charge to an electron and to be located at right angles to the moving electron. This particle must be very small to penetrate all known elements in their various states as well as their known compounds (unless they have unpaired electrons which capture these particles as they endeavour to pass through).

The electrons in ferrous materials differ from those found in most elements in that they are unpaired, and being unpaired they spin around the nucleus in such a way that they respond to magnetic fields as well as creating a magnetic field themselves. If they were paired, their magnetic fields would cancel out. However, being unpaired they create a measurable magnetic field if their spins are orientated in one direction. The spins are at right angles to their magnetic fields.

In niobium superconductors, at a critical state, the magnetic lines of force cease to be at right angles. This change must be due to establishing the required conditions for unpaired electronic spins instead of electron flow in the conductor, and the fact that very powerful electromagnets can be formed with superconductors illustrates the tremendous advantage of producing the magnetic field by unpaired electron spins rather than conventional electron flow. In a superconducting metal, wherein the electrical resistance becomes greater in the metal than the proton resistance, the flow turns to electron spins and the positive particles flow parallel in the metal in the manner occurring in a permanent magnet where a powerful flow of magnetic positive particles or magnetic flux

causes the unpaired electrons to spin at right angles. Under cryogenic superconduction conditions the freezing of the crystals in place makes it possible for the spins to continue, and in a permanent magnet the grain orientation of the magnetised material allows these spins, permitting them to continue and causing the flux to flow parallel to the metal. In a superconductor, at first the electron is flowing and the positive particle is spinning; later, when critical, the reverse occurs, i.e., the electron is spinning and the positive particle is flowing at right angles. These positive particles will thread or work their way through the electron spins present in the metal.

In a sense, a permanent magnet may be considered a room-temperature superconductor. It is a superconductor because the electron flow does not cease, and this electron flow can be made to do work through the magnetic field which it creates. Previously, this source of power has not been used because it was not possible to modify the electron flow to accomplish the switching functions of the magnetic field. Such switching functions are common in a conventional electric motor where electrical current is employed to align the much greater electron current in the iron pole pieces and concentrate the magnetic field at the proper places to give the thrust necessary to move the motor armature. In a conventional electric motor, switching is accomplished by the use of brushes, commutators, alternating current, or other means.

In order to accomplish the switching function in a permanent magnet motor, it is necessary to shield the magnetic leakage so that it will not appear as too great a loss factor at the wrong places. The best method to accomplish this is to concentrate the magnetic flux in the place where it will be the most effective. Timing and switching can be achieved in a permanent magnet motor by concentrating the flux and using the proper geometry of the motor rotor and stator to make most effective use of the magnetic fields. By the proper combination of materials, geometry and magnetic concentration, it is possible to achieve a mechanical advantage of high ratio, greater than 100 to 1, capable of producing continuous motive force.

To my knowledge, previous work done with permanent magnets, and motive devices utilising permanent magnets, have not achieved the result desired in the practice of the inventive concept, and it is with the proper combination of materials, geometry and magnetic concentration that the presence of the magnetic spins within a permanent magnet may be utilised as a motive force.

SUMMARY OF THE INVENTION:

It is an object of the invention to utilise the magnetic spinning phenomenon of unpaired electrons occurring in ferromagnetic material to produce the movement of a mass in a unidirectional manner so as to permit a motor to be driven solely by the magnetic forces occurring within permanent magnets. Both linear and rotational types of motor may be produced. It is an object of the invention to provide the proper combination of materials, geometry and magnetic concentration to power a motor. Whether the motor is a linear type or a rotary type, in each instance the "stator" may consist of several permanent magnets fixed relative to each other, to create a track. This track is linear for a linear motor and circular for a rotary motor. An armature magnet is carefully positioned above this track so that an air gap exists between it and the track. The length of the armature magnet is defined by poles of opposite polarity, and the longer axis of the armature magnet is pointed in the direction of its movement.

The stator magnets are mounted so that all the same poles face the armature magnet. The armature magnet has poles which are both attracted to and repelled by the adjacent pole of the stator magnets, so both attractive and repulsive forces act upon the armature magnet to make it move.

The continuing motive force which acts on the armature magnet is caused by the relationship of the length of the armature magnet to the width and spacing of the stator magnets. This ratio of magnet and magnet spacings, and with an acceptable air gap spacing between the stator and armature magnets, produces a continuous force which causes the movement of the armature magnet.

In the practice of the invention, movement of the armature magnet relative to the stator magnets results from a combination of attractive and repulsive forces between the stator and armature magnets. By concentrating the magnetic fields of the stator and armature magnets the motive force imposed upon the armature magnet is intensified, and in the disclosed embodiments, the means for achieving this magnetic field concentration are shown.

This method comprises of a plate of high magnetic field permeability placed behind one side of the stator magnets and solidly engaged with them. The magnetic field of the armature magnet may be concentrated and directionally oriented by bowing the armature magnet, and the magnetic field may further be concentrated by shaping the pole ends of the armature magnet to concentrate the magnet field at a relatively limited surface at the armature magnet pole ends.

Preferably, several armature magnets are used and these are staggered relative to each other in the direction their movement. Such an offsetting or staggering of the armature magnets distributes the impulses of force

imposed upon the armature magnets and results in a smoother application of forces to the armature magnet producing a smoother and more uniform movement of the armature component.

In the rotary embodiment of the permanent magnet motor of the invention the stator magnets are arranged in a circle, and the armature magnets rotate about the stator magnets. A mechanism is shown which can move the armature relative to the stator and this controls the magnitude of the magnetic forces, altering the speed of rotation of the motor.

BRIEF DESCRIPTION OF THE DRAWINGS

The objects and advantages of the invention mentioned earlier, will be appreciated from the following description and accompanying drawings:

- Fig. 1** is a schematic view of electron flow in a superconductor indicating the unpaired electron spins,
- Fig. 2** is a cross-sectional view of a superconductor under a critical state illustrating the electron spins,
- Fig. 3** is a view of a permanent magnet illustrating the flux movement through it,
- Fig. 4** is a cross-sectional view illustrating the diameter of the magnet of Fig.3,
- Fig. 5** is an elevational representation of a linear motor embodiment of the permanent magnet motor of the invention illustrating one position of the armature magnet relative to the stator magnets, and indicating the magnetic forces imposed upon the armature magnet,
- Fig. 6** is a view similar to Fig.5 illustrating displacement of the armature magnet relative to the stator magnets, and the influence of magnetic forces thereon at this location,
- Fig. 7** is a further elevational view similar to Fig.5 and Fig.6 illustrating further displacement of the armature magnet to the left, and the influence of the magnetic forces thereon,
- Fig. 8** is a top plan view of a linear embodiment of the inventive concept illustrating a pair of armature magnets in linked relationship disposed above the stator magnets,
- Fig. 9** is a diametrical, elevational, sectional view of a rotary motor embodiment in accord with the invention as taken along section IX-IX of Fig.10, and
- Fig. 10** is an elevational view of the rotary motor embodiment as taken along X-X of Fig.9.

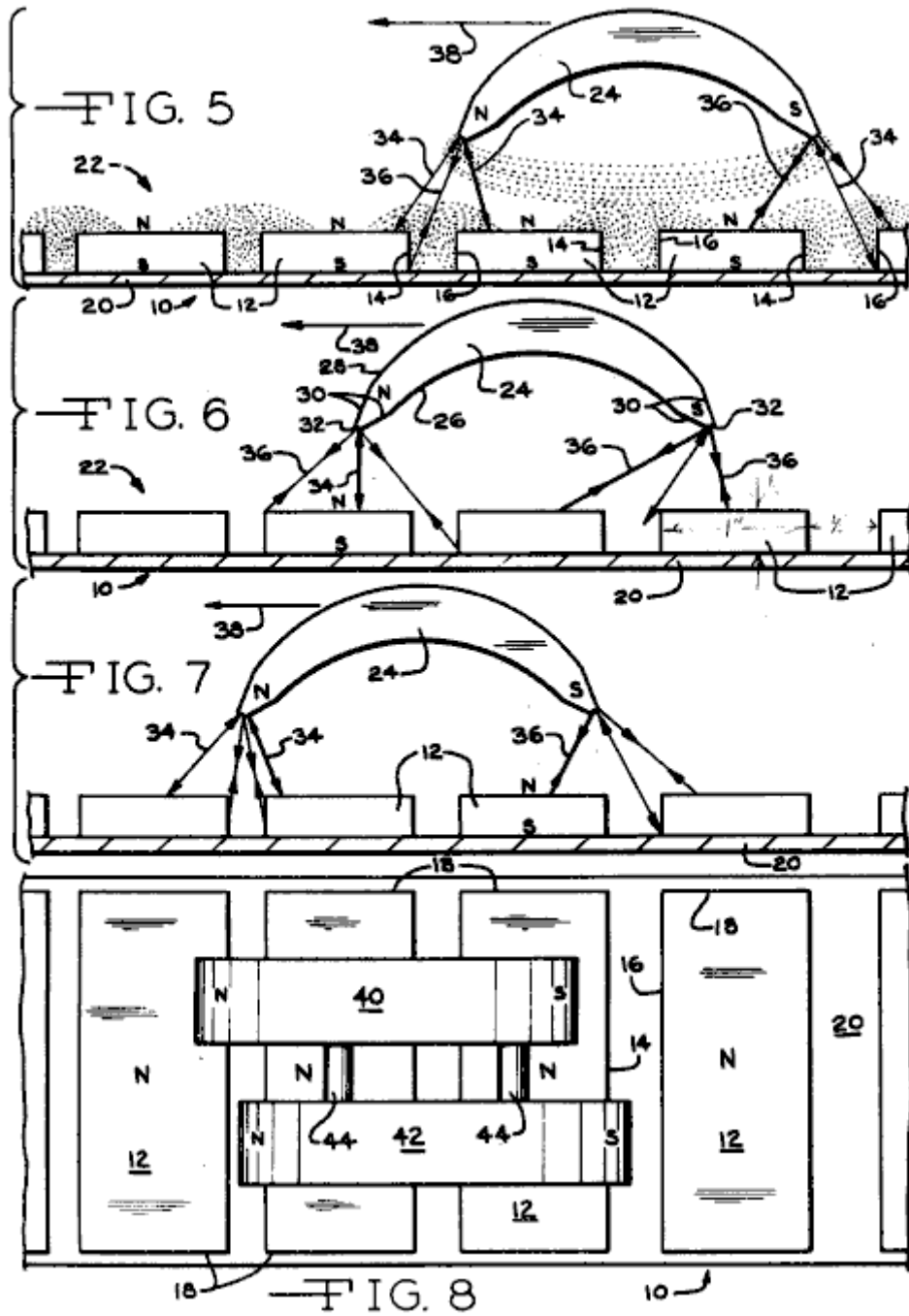

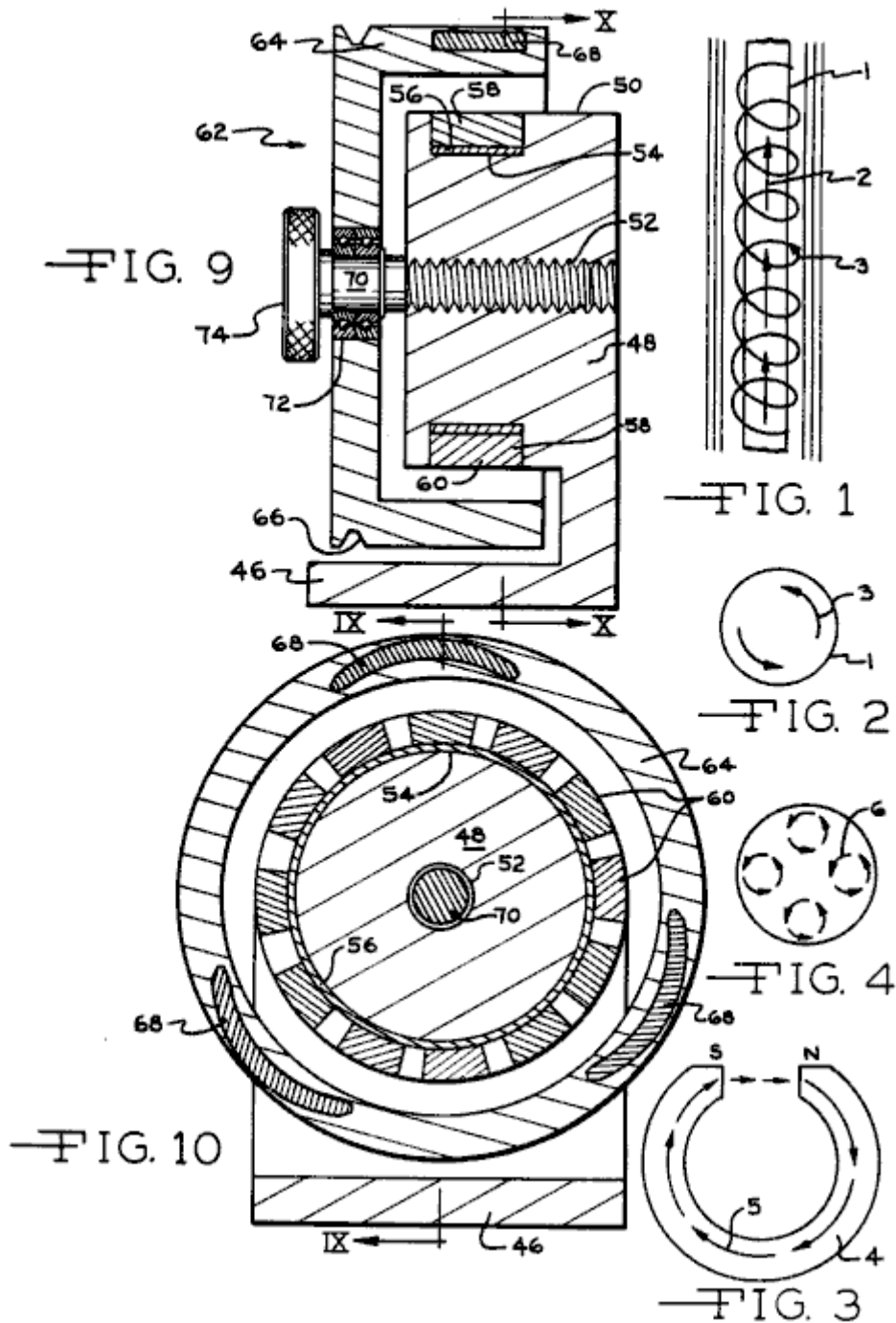

DESCRIPTION OF THE PREFERRED EMBODIMENTS

In order to better understand the theory of the inventive concept, reference is made to **Figs. 1 through 4**. In **Fig.1** a superconductor 1 is illustrated having a positive particle flow as represented by arrow 2, the unpaired electrons of the ferrous conductor 1 spin at right angles to the proton flow in the conductor as represented by the spiral line and arrow 3. In accord with the theory of the invention the spinning of the ferrous unpaired electrons results from the atomic structure of ferrous materials and this spinning atomic particle is believed to be opposite in charge and located at right angles to the moving electrons. It is assumed to be very small in size capable of penetrating other elements and their compounds unless they have unpaired electrons which capture these particles as they endeavour to pass through.

The lack of electrical resistance of conductors at a critical superconductor state has long been recognised, and superconductors have been utilised to produce very high magnetic flux density electromagnets. **Fig.2** represents a cross section of a critical superconductor and the electron spins are indicated by the arrows 3. A permanent magnet may be considered a superconductor as the electron flow therein does not cease, and is without resistance, and unpaired electric spinning particles exist which, in the practice of the invention, are utilised to produce motor force. **Fig.3** illustrates a horseshoe shaped permanent magnet at 4 and the magnetic flux through it is indicated by arrows 5, the magnetic flow being from the south pole to the north pole and through the magnetic material. The accumulated electron spins occurring about the diameter of the magnet 5 are represented at 6 in

Fig.4, and the spinning electron particles spin at right angles in the iron as the flux travels through the magnet material.

By utilising the electron spinning theory of ferrous material electrons, it is possible with the proper ferromagnetic materials, geometry and magnetic concentration to utilise the spinning electrons to produce a motive force in a continuous direction, thereby resulting in a motor capable of doing work.

It is appreciated that the embodiments of motors utilising the concepts of the invention may take many forms, and in the illustrated forms the basic relationships of components are illustrated in order to disclose the inventive concepts and principles. The relationships of the plurality of magnets defining the stator **10** are best appreciated from **Figs. 5 through 8**. The stator magnets **12** are preferably of a rectangular configuration, **Fig.8**, and so magnetised that the poles exist at the large surfaces of the magnets, as will be appreciated from the N (North) and S (South) designations. The stator magnets include side edges **14** and **16** and end edges **18**. The stator magnets are mounted upon a supporting plate **20**, which is preferably of a metal having a high permeability to magnetic fields and magnetic flux such as that available under the trademark Netic CoNetic sold by Perfection Mica Company of Chicago, Illinois. Thus, the plate **20** will be disposed toward the south pole of the stator magnets **12**, and preferably in direct engagement therewith, although a bonding material may be interposed between the magnets and the plate in order to accurately locate and fix the magnets on the plate, and position the stator magnets with respect to each other.

Preferably, the spacing between the stator magnets **12** slightly differs between adjacent stator magnets as such a variation in spacing varies the forces being imposed upon the armature magnet at its ends, at any given time, and thus results in a smoother movement of the armature magnet relative to the stator magnets. Thus, the stator magnets so positioned relative to each other define a track **22** having a longitudinal direction left to right as viewed in **Figs. 5 through 8**.

In **Figs. 5 through 7** only a single armature magnet **24** is disclosed, while in **Fig.8** a pair of armature magnets are shown. For purposes of understanding the concepts of the invention the description herein will be limited to the use of single armature magnet as shown in **Figs. 5 through 7**.

The armature magnet is of an elongated configuration wherein the length extends from left to right, **Fig.5**, and may be of a rectangular transverse cross-sectional shape. For magnetic field concentrating and orientation purposes the magnet **24** is formed in an arcuate bowed configuration as defined by concave surfaces **26** and convex surfaces **28**, and the poles are defined at the ends of the magnet as will be appreciated from **Fig.5**. For further magnetic field concentrating purposes the ends of the armature magnet are shaped by bevelled surfaces **30** to minimise the cross sectional area at the magnet ends **32**, and the magnetic flux existing between the poles of the armature magnet are as indicated by the light dotted lines. In like manner the magnetic fields of **6** the stator magnets **12** are indicated by the light dotted lines.

The armature magnet **24** is maintained in a spaced relationship above the stator track **22**. This spacing may be accomplished by mounting the armature magnet upon a slide, guide or track located above the stator magnets, or the armature magnet could be mounted upon a wheeled vehicle carriage or slide supported upon a non-magnetic surface or guideway disposed between the stator magnets and the armature magnet. To clarify the illustration, the means for supporting the armature magnet **24** is not illustrated and such means form no part of invention, and it is to be understood that the means supporting the armature magnet prevents the armature magnet from moving away from the stator magnets, or moving closer thereto, but permits free movement of the armature magnet to the left or right in a direction parallel to the track **22** defined by the stator magnets.

It will be noted that the length of the armature magnet **24** is slightly greater than the width of two of the stator magnets **12** and the spacing between them. The magnetic forces acting upon the armature magnet when in the position of **Fig.5** will be repulsion forces **34** due to the proximity of like polarity forces and attraction forces at **36** because of the opposite polarity of the south pole of the armature magnet, and the north pole field of the sector magnets. The relative strength of this force is represented by the thickness of the force line.

The resultant of the force vectors imposed upon the armature magnet as shown in **Fig.5** produce a primary force vector **38** toward the left, **Fig.5**, displacing the armature magnet **24** toward the left. In **Fig.6** the magnetic forces acting upon the armature magnet are represented by the same reference numerals as in **Fig.5**. While the forces **34** constitute repulsion forces tending to move the north pole of the armature magnet away from the stator magnets, the attraction forces imposed upon the south pole of the armature magnet and some of the repulsion forces, tend to move the armature magnet further to the left, and as the resultant force **38** continues to be toward the left the armature magnet continues to be forced to the left. **Fig.7** represents further displacement of the armature magnet **24** to the left with respect to the position of **Fig.6**, and the magnetic forces acting thereon are represented by the same reference numerals as in **Fig.5** and **Fig.6**, and the stator magnet will continue to move to the left, and such movement continues the length of the track **22** defined by the stator magnets **12**.

Upon the armature magnet being reversed such that the north pole is positioned at the right as viewed in **Fig.5**, and the south pole is positioned at the left, the direction of movement of the armature magnet relative to the stator magnets is toward the right, and the theory of movement is identical to that described above.

In **Fig.8** a plurality of armature magnets **40** and **42** are illustrated which are connected by links **44**. The armature magnets are of a shape and configuration identical to that of the embodiment of **Fig.5**, but the magnets are staggered with respect to each other in the direction of magnet movement, i.e., the direction of the track **22** defined by the stator magnets **12**. By so staggering a plurality of armature magnets a smoother movement of the interconnected armature magnets is produced as compared when using a single armature magnet as there is variation in the forces acting upon each armature magnet as it moves above the track **22** due to the change in magnetic forces imposed thereon. The use of several armature magnets tends to "smooth out" the application of forces imposed upon linked armature magnets, resulting in a smoother movement of the armature magnet assembly. Of course, any number of armature magnets may be interconnected, limited only by the width of the stator magnet track **22**.

In **Fig.9** and **Fig.10** a rotary embodiment embracing the inventive concepts is illustrated. In this embodiment the principle of operation is identical to that described above, but the orientation of the stator and armature magnets is such that rotation of the armature magnets is produced about an axis, rather than a linear movement being achieved.

In **Fig.9** and **Fig.10** a base is represented at **46** serving as a support for a stator member **48**. The stator member **48** is made of a non-magnetic material, such as synthetic plastic, aluminium, or the like. The stator includes a cylindrical surface **50** having an axis, and a threaded bore **52** is concentrically defined in the stator. The stator includes an annular groove **54** receiving an annular sleeve **56** of high magnetic field permeability material such as Netic Co-Netic and a plurality of stator magnets **58** are affixed upon the sleeve **56** in spaced circumferential relationship as will be apparent in **Fig.10**. Preferably, the stator magnets **58** are formed with converging radial sides as to be of a wedge configuration having a curved inner surface engaging sleeve **56**, and a convex pole surface **60**.

The armature **62**, in the illustrated embodiment, is of a dished configuration having a radial web portion, and an axially extending portion **64**. The armature **62** is formed of a non-magnetic material, and an annular belt receiving groove **66** is defined therein for receiving a belt for transmitting power from the armature to a generator, or other power consuming device. Three armature magnets **68** are mounted on the armature portion **64**, and such magnets are of a configuration similar to the armature magnet configuration of **Figs. 5 through 7**.

The magnets **68** are staggered with respect to each other in a circumferential direction wherein the magnets are not placed exactly 120 degrees apart but instead, a slight angular staggering of the armature magnets is desirable to "smooth out" the magnetic forces being imposed upon the armature as a result of the magnetic forces being simultaneously imposed upon each of the armature magnets. The staggering of the armature magnets **68** in a circumferential direction produces the same effect as the staggering of the armature magnets **40** and **42** as shown in **Fig.8**.

The armature **62** is mounted upon a threaded shaft **70** by anti-friction bearings **72**, and the shaft **70** is threaded into the stator threaded bore **52**, and may be rotated by the knob **74**. In this manner rotation of the knob **74**, and shaft **70**, axially displaces the armature **62** with respect to the stator magnets **58**, and such axial displacement will vary the magnitude of the magnetic forces imposed upon the armature magnets **68** by the stator magnets thereby controlling the speed of rotation of the armature. As will be noted from **Figs. 4 to 7, 9 and 10**, an air gap exists between the armature magnets and the stator magnets and the dimension of this spacing, effects the magnitude of the forces imposed upon the armature magnet or magnets. If the distance between the armature magnets and the stator magnets is reduced the forces imposed upon the armature magnets by the stator magnets are increased, and the resultant force **8** vector tending to displace the armature magnets in their path of movement increases. However, the decreasing of the spacing between the armature and stator magnets creates a "pulsation" in the movement of the armature magnets which is objectionable, but can be, to some extent, minimised by using a plurality of armature magnets. Increasing the distance between the armature and stator magnets reduces the pulsation tendency of the armature magnet, but also reduces the magnitude of the magnetic forces imposed upon the armature magnets. Thus, the most effective spacing between the armature and stator magnets is that spacing which produces the maximum force vector in the direction of armature magnet movement, with a minimum creation of objectionable pulsation.

In the disclosed embodiments the high permeability plate **20** and sleeve **56** are disclosed for concentrating the magnetic field of the stator magnets, and the armature magnets are bowed and have shaped ends for magnetic field concentration purposes. While such magnetic field concentration means result in higher forces imposed upon

the armature magnets for given magnet intensities, it is not intended that the inventive concepts be limited to the use of such magnetic field concentrating means.

As will be appreciated from the above description of the invention, the movement of the armature magnet or magnets results from the described relationship of components. The length of the armature magnets as related to the width of the stator magnets and spacing between them, the dimension of the air gap and the configuration of the magnetic field, combined, produce the desired result and motion. The inventive concepts may be practised even though these relationships may be varied within limits not yet defined and the invention is intended to encompass all dimensional relationships which achieve the desired goal of armature movement. By way of example, with respect to **Figs. to 7**, the following dimensions were used in an operating prototype:

The length of armature magnet **24** is 3.125", the stator magnets **12** are 1" wide, .25" thick and 4" long and grain oriented. The air gap between the poles of the armature magnet and the stator magnets is approximately 1.5" and the spacing between the stator magnets is approximately .5" inch.

In effect, the stator magnets define a magnetic field track of a single polarity transversely interrupted at spaced locations by the magnetic fields produced by the lines of force existing between the poles of the stator magnets and the unidirectional force exerted on the armature magnet is a result of the repulsion and attraction forces existing as the armature magnet traverses this magnetic field track.

It is to be understood that the inventive concept embraces an arrangement wherein the armature magnet component is stationary and the stator assembly is supported for movement and constitutes the moving component, and other variations of the inventive concept will be apparent to those skilled in the art without departing from the scope thereof. As used herein the term "track" is intended to include both linear and circular arrangements of the static magnets, and the "direction" or "length" of the track is that direction parallel or concentric to the intended direction of armature magnet movement.

CLAIMS

1. A permanent magnet motor comprising, in combination, a stator track defining a track direction and having first and second sides and composed of a plurality of track permanent magnets each having first and second poles of opposite polarity, said magnets being disposed in side-by-side relationship having a spacing between adjacent magnets and like poles defining said track sides, an elongated armature permanent magnet located on one of said track sides for relative movement thereto and in spaced relationship to said track side wherein an air gap exists between said armature magnet and said track magnets, said armature magnet having first and second poles of opposite polarity located at the opposite ends of said armature magnet deeming the length thereof, the length of said armature magnet being disposed in a direction in general alignment with the direction of said track, the spacing of said armature magnet poles from said track associated side and the length of said armature magnet as related to the width and spacing of said track magnets in the direction of said track being such as to impose a continuous force on said armature magnet in said general direction of said track.
2. In a permanent magnet motor as in claim 1 wherein the spacing between said poles of said armature and the adjacent stator track side are substantially equal.
3. In a permanent magnet motor as in claim 1 wherein the spacing between adjacent track magnets varies.
4. In a permanent magnet motor as in claim 1 wherein a plurality of armature magnets are disposed on a common side of said stator track, said armature magnets being mechanically interconnected.
5. In a permanent magnet motor as in claim 4 wherein said armature magnets are staggered with respect to each other in the direction of said track.
6. In a permanent magnet motor as in claim 1 wherein magnetic field concentrating means are associated with said track magnets.
7. In a permanent magnet motor as in claim 6 wherein said field concentrating means comprises a sheet of magnetic material of high field permeability engaging side and pole of said track opposite to that side and pole disposed toward said armature magnet.
8. In a permanent magnet as in claim 1 wherein said armature magnet is of an arcuate configuration in its longitudinal direction bowed toward said track, said armature magnet having ends shaped to concentrate the magnetic field at said ends.

9. In a permanent magnet motor as in claim 1 wherein said stator track is of a generally linear configuration, and means supporting said armature magnet relative to said track for generally linear movement of said armature magnet.
10. In a permanent magnet motor as in claim 1 wherein said stator track magnets define a circle having an axis, an armature rotatably mounted with respect to said track and concentric and coaxial thereto, said armature magnet being mounted upon said armature.
11. In a permanent magnet motor as in claim 10, means axially adjusting said armature relative to said track whereby the axial relationship of said armature magnet and said stator magnets may be varied to adjust the rate of rotation of said armature.
12. In a permanent magnet motor as in claim 10 wherein a plurality of armature magnets are mounted on said armature.
13. In a permanent magnet motor as in claim 12 wherein said armature magnets are circumferentially non-uniformly spaced on said armature.
14. A permanent magnet motor comprising, in combination, a stator comprising a plurality of circumferentially spaced stator permanent magnets having poles of opposite polarity, said magnets being arranged to substantially define a circle having an axis, the poles of said magnets facing in a radial direction with respect to said axis and poles of the same polarity facing away from said axis and the poles of opposite polarity facing toward said axis, an armature mounted for rotation about said axis and disposed adjacent said stator, at least one armature permanent magnet having poles of opposite polarity mounted on said armature and in radial spaced relationship to said circle of stator magnets, said armature magnet poles extending in the circumferential direction of armature rotation, the spacing of said armature magnet poles from said stator magnets and the circumferential length of said armature magnet and the spacing of said stator magnets being such as to impose a continuing circumferential force on said armature magnet to rotate said armature.
15. In a permanent magnet motor as in claim 14 wherein a plurality of armature magnets are mounted upon said armature.
16. In a permanent magnet motor as in claim 14 wherein said armature magnets are asymmetrically circumferentially spaced on said armature.
17. In a permanent magnet motor as in claim 14 wherein the poles of said armature magnet are shaped to concentrate the magnetic field thereof.
18. In a permanent magnet motor as in claim 14, magnetic field concentrating means associated with said stator magnets concentrating the magnetic fields thereof at the spacings between adjacent stator magnets.
19. In a permanent magnet motor as in claim 18 wherein said magnet field concentrating means comprises an annular ring of high magnetic field permeability material concentric with said axis and in substantial engagement with poles of like polarity of said stator magnets.
20. In a permanent magnet motor as in claim 14 wherein said armature magnet is of an arcuate bowed configuration in the direction of said poles thereof defining a concave side and a convex side, said concave side being disposed toward said axis, and said poles of said armature magnet being shaped to concentrate the magnetic field between said poles thereof.
21. In a permanent magnet motor as in claim 14, means for axially displacing said stator and armature relative to each other to adjust the axial alignment of said stator and armature magnets.
22. The method of producing a unidirectional motive force by permanent magnets using a plurality of spaced stator permanent magnets having opposite polarity poles defining a track having a predetermined direction, and an armature magnet having a length defined by poles of opposite polarity movably mounted for movement relative to the track in the direction thereof, and of a predetermined length determined by the width and dimensions of said stator magnets comprising forming a magnetic field track by said stator magnets having a magnetic field of common polarity interrupted at spaced locations in a direction transverse to the direction of said magnetic field track by magnetic fields created by magnetic lines of force existing between the poles of the stator magnets and positioning the armature magnet in spaced relation to said magnetic field track longitudinally related to the direction of the magnetic field track such a distance that the repulsion and attraction forces imposed on the armature magnet by said magnetic field track imposes a continuing unidirectional force on the armature magnet in the direction of the magnetic field track.

23. The method of producing a unidirectional motive force as in claim 22 including concentrating the magnetic fields created by magnetic lines of force between the poles of the stator magnets.
24. The method of producing a unidirectional motive force as in claim 22 including concentrating the magnetic field existing between the poles of the armature magnet.
25. The method of producing a unidirectional motive force as in claim 22 including concentrating the magnetic fields created by magnetic lines of force between the poles of the stator magnets and concentrating the magnetic field existing between the poles of the armature magnet.
26. The method of producing a motive force by permanent magnets wherein the unpaired electron spinning particles existing within a permanent magnet are utilised for producing a motive force comprising forming a stator magnetic field track by means of at least one permanent magnet, producing an armature magnetic field by means of a permanent magnet and shaping and locating said magnetic fields in such a manner as to produce relative continuous unidirectional motion between said stator and armature field producing magnets.
27. The method of producing a motive force by permanent magnets as in claim 26 wherein said stator magnetic field is substantially of a single polarity.
28. The method of producing a motive force by permanent magnets as in claim 26 including concentrating the magnetic field of said stator field track and armature magnetic field.

HAROLD EWING

US Patent 5,625,241

29th April 1997

Inventor: Harold E. Ewing et al.

CAROUSEL ELECTRIC GENERATOR

This is a reworded excerpt from this patent which shows a compact, self-powered, combined permanent magnet motor and electrical generator. There is a little extra information at the end of this document.

ABSTRACT

A permanent magnet generator or motor having stationary coils positioned in a circle, a rotor on which are mounted permanent magnets grouped in sectors and positioned to move adjacent to the coils, and a carousel carrying corresponding groups of permanent magnets through the centres of the coils, the carousel moves with the rotor by virtue of its being magnetically coupled to it.

Inventors:

Ewing, Harold E. (Chandler, AZ, US)
Chapman, Russell R. (Mesa, AZ, US)
Porter, David R. (Mesa, AZ, US)

Assignee:

Energy Research Corporation (Mesa, AZ)

US Patent References:

3610974	Oct, 1971	Kenyon	310/49.
4547713	Oct, 1985	Langley et al.	318/254.
5117142	May, 1992	Von Zweygbergk	310/156.
5289072	Feb, 1994	Lange	310/266.
5293093	Mar, 1994	Warner	310/254.
5304883	Apr, 1994	Denk	310/180.

BACKGROUND OF THE INVENTION

There are numerous applications for small electric generators in ratings of a few kilowatts or less. Examples include electric power sources for emergency lighting in commercial and residential buildings, power sources for remote locations such as mountain cabins, and portable power sources for motor homes, pleasure boats, etc.

In all of these applications, system reliability is a primary concern. Because the power system is likely to sit idle for long periods of time without the benefit of periodic maintenance, and because the owner-operator is often inexperienced in the maintenance and operation of such equipment, the desired level of reliability can only be achieved through system simplicity and the elimination of such components as batteries or other secondary power sources which are commonly employed for generator field excitation.

Another important feature for such generating equipment is miniaturisation particularly in the case of portable equipment. It is important to be able to produce the required level of power in a relatively small generator.

Both of these requirements are addressed in the present invention through a novel adaptation of the permanent magnet generator or magneto in a design that lends itself to high frequency operation as a means for maximising power output per unit volume.

DESCRIPTION OF THE PRIOR ART

Permanent magnet generators or magnetos have been employed widely for many years. Early applications of such generators include the supply of electric current for spark plugs in automobiles and aeroplanes. Early telephones used magnetos to obtain electrical energy for ringing. The Model T Ford automobile also used magnetos to power its electric lights.

The present invention differs from prior art magnetos in terms of its novel physical structure in which a multiplicity of permanent magnets and electrical windings are arranged in a fashion which permits high-speed/high-frequency operation as a means for meeting the miniaturisation requirement. In addition, the design is enhanced through the

use of a rotating carousel which carries a multiplicity of field source magnets through the centres of the stationary electric windings in which the generated voltage is thereby induced.

SUMMARY OF THE INVENTION

In accordance with the invention claimed, an improved permanent magnet electric generator is provided with a capability for delivering a relatively high level of output power from a small and compact structure. The incorporation of a rotating carousel for the transport of the primary field magnets through the electrical windings in which induction occurs enhances field strength in the locations critical to generation.

It is, therefore, one object of this invention to provide an improved permanent magnet generator or magneto for the generation of electrical power. Another object of this invention is to provide in such a generator a relatively high level of electrical power from a small and compact structure. A further object of this invention is to achieve such a high level of electrical power by virtue of the high rotational speed and high frequency operation of which the generator of the invention is capable.

A further object of this invention is to provide such a high frequency capability through the use of a novel field structure in which the primary permanent magnets are carried through the centres of the induction windings of the generator by a rotating carousel.

A still further object of this invention is to provide a means for driving the rotating carousel without the aid of mechanical coupling but rather by virtue of magnetic coupling between other mechanically driven magnets and those mounted on the carousel.

A still further object of this invention is to provide an enhanced capability for high speed/high frequency operation through the use of an air bearing as a support for the rotating carousel.

Yet another object of this invention is to provide in such an improved generator a sufficiently high magnetic field density in the locations critical to voltage generation without resort to the use of laminations or other media to channel the magnetic field.

Further objects and advantages of the invention will become apparent as the following description proceeds and the features of novelty which characterise the invention will be pointed out with particularity in the claims annexed to and forming a part of this specification.

BRIEF DESCRIPTION OF THE DRAWINGS

The present invention may be more readily described by reference to the accompanying drawings, in which:

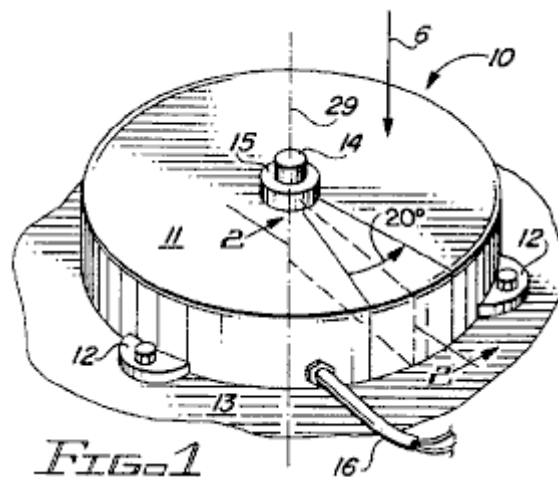

Fig.1 is a simplified perspective view of the carousel electric generator of the invention;

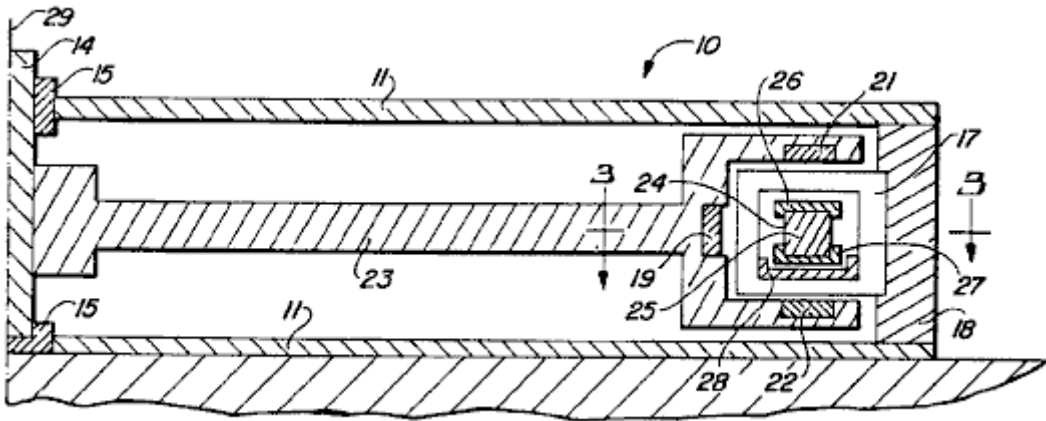

FIG. 2

Fig. 2 is a cross-sectional view of Fig. 1 taken along line 2--2;

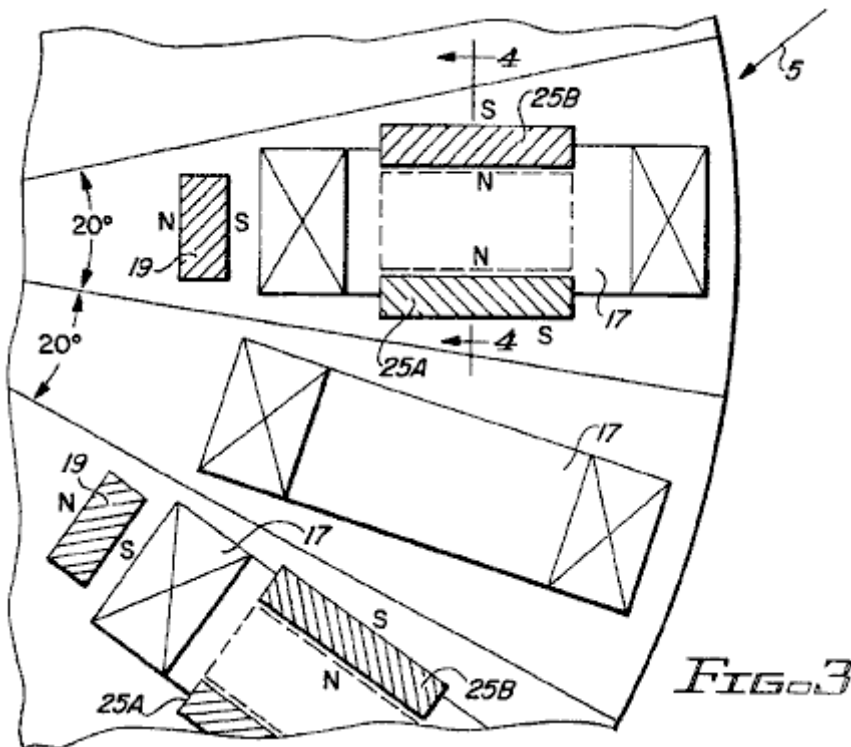

FIG. 3

Fig. 3 is a cross-sectional view of the generator of Fig. 1 and Fig. 2 taken along line 3--3 of Fig. 2;

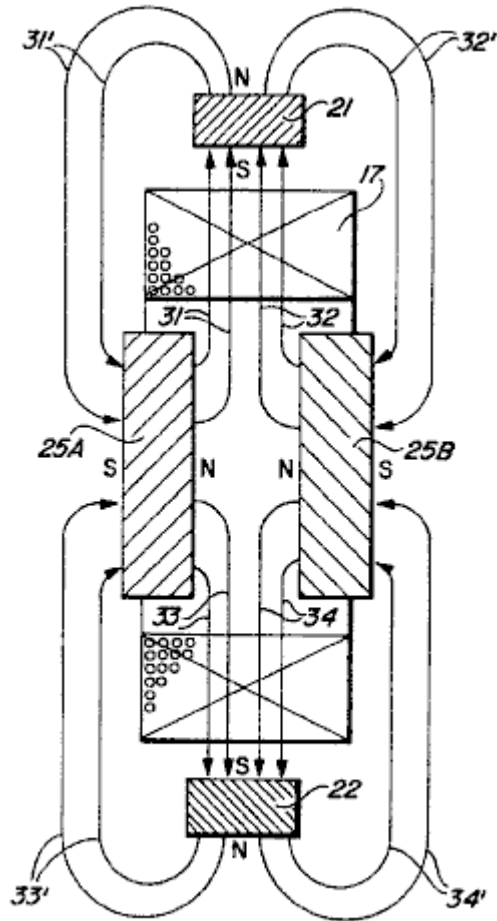

FIG. 4

Fig.4 is a cross-sectional view of Fig.3 taken along line 4--4;

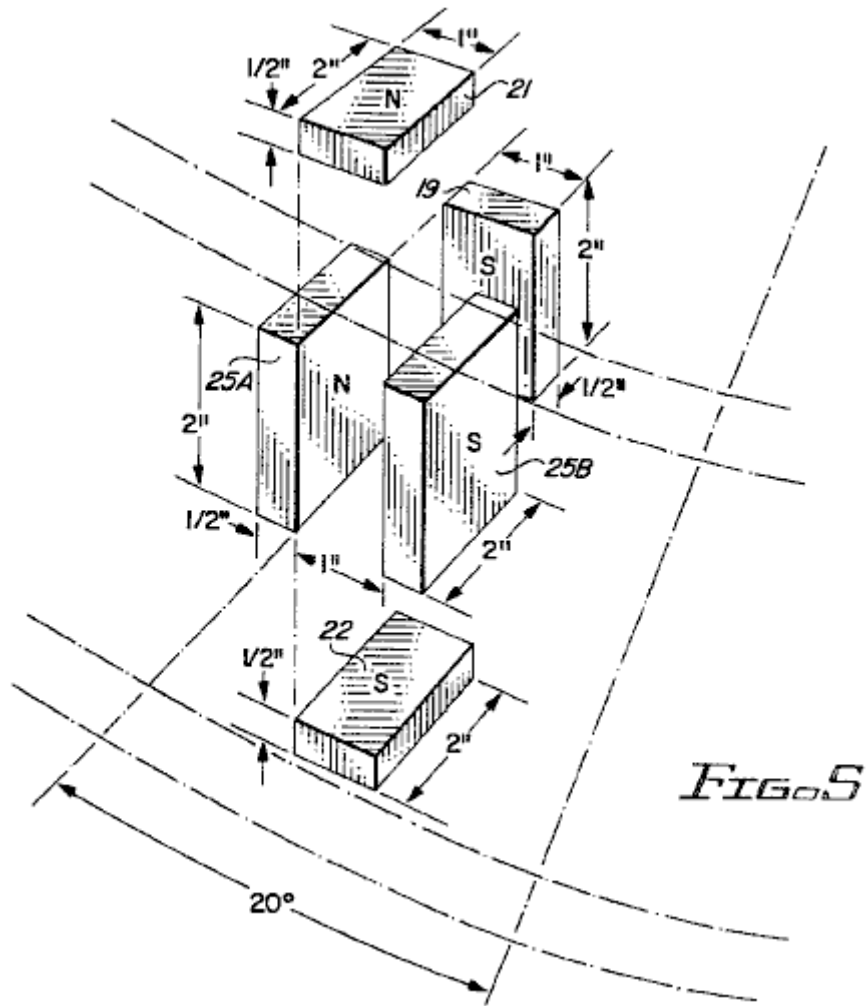

Fig.5 is a partial perspective view showing the orientation of a group of permanent magnets within a twenty degree sector of the generator of the invention as viewed in the direction of arrow **5** of **Fig.3**;

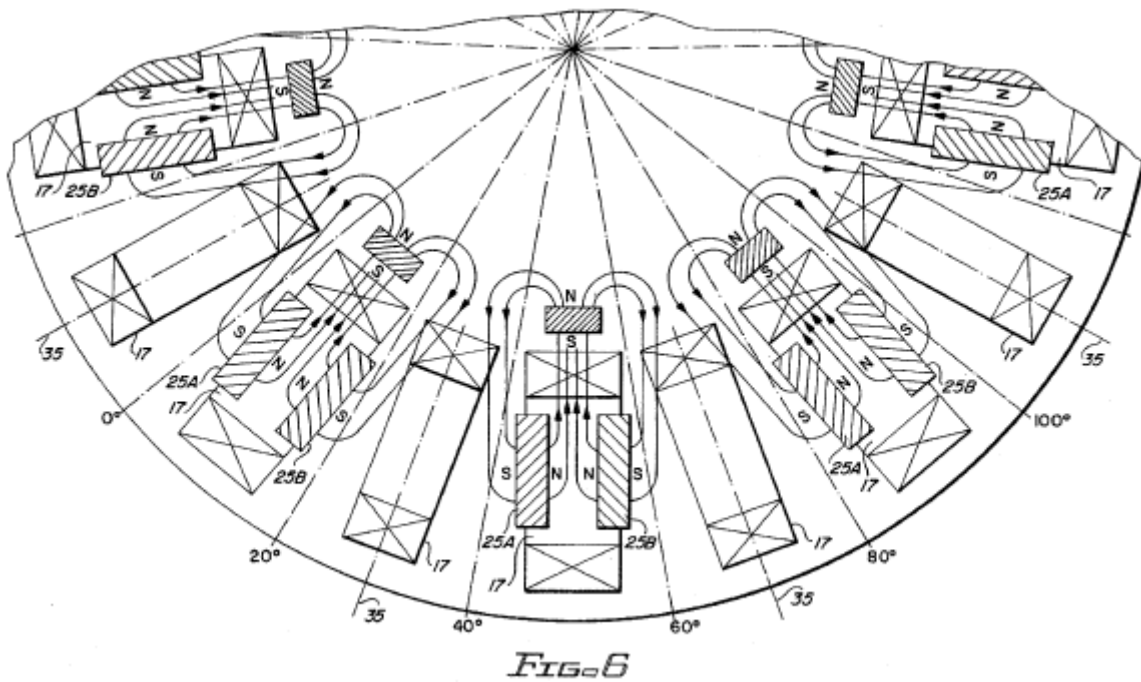

Fig.6 is an illustration of the physical arrangement of electrical windings and permanent magnets within the generator of the invention as viewed in the direction of arrow **6** in **Fig.1**;

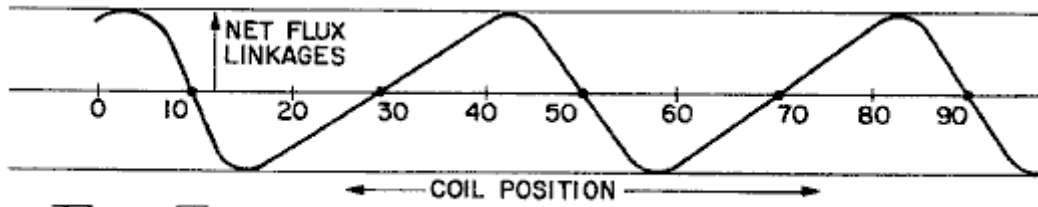

FIG. 7

Fig.7 is a wave form showing flux linkages for a given winding as a function of rotational position of the winding relative to the permanent magnets;

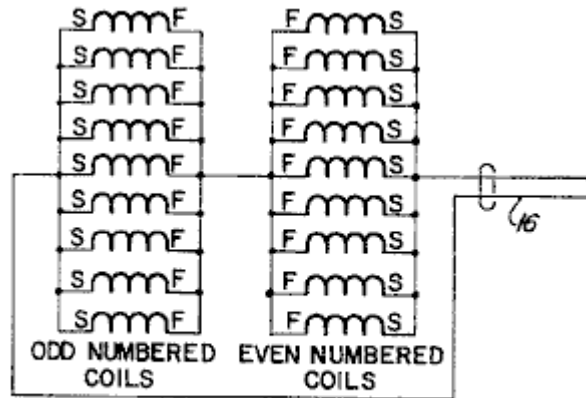

FIG. 8

Fig.8 is a schematic diagram showing the proper connection of the generator windings for a high current low voltage configuration of the generator;

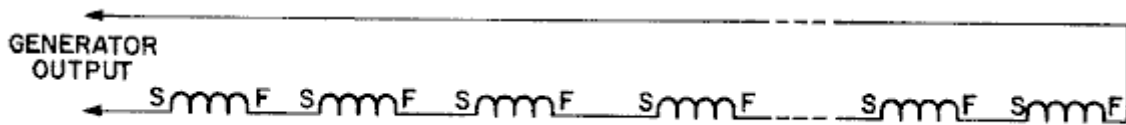

FIG. 9

Fig.9 is a schematic diagram showing a series connection of generator coils for a low current, high voltage configuration;

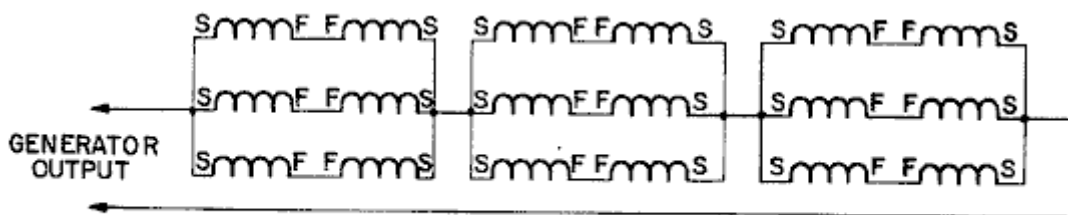

FIG. 10

Fig.10 is a schematic diagram showing a series/parallel connection of generator windings for intermediate current and voltage operation;

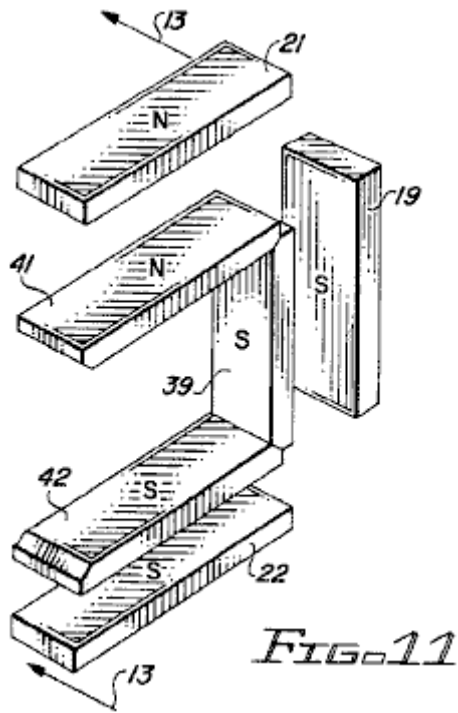

Fig.11 is a perspective presentation of a modified carousel magnet configuration employed in a second embodiment of the invention;

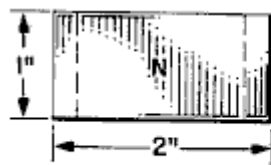

FIG. 12A

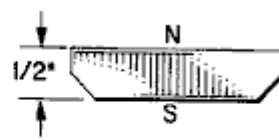

FIG. 12B

Fig.12A and **Fig.12B** show upper and lower views of the carousel magnets of **Fig.11**;

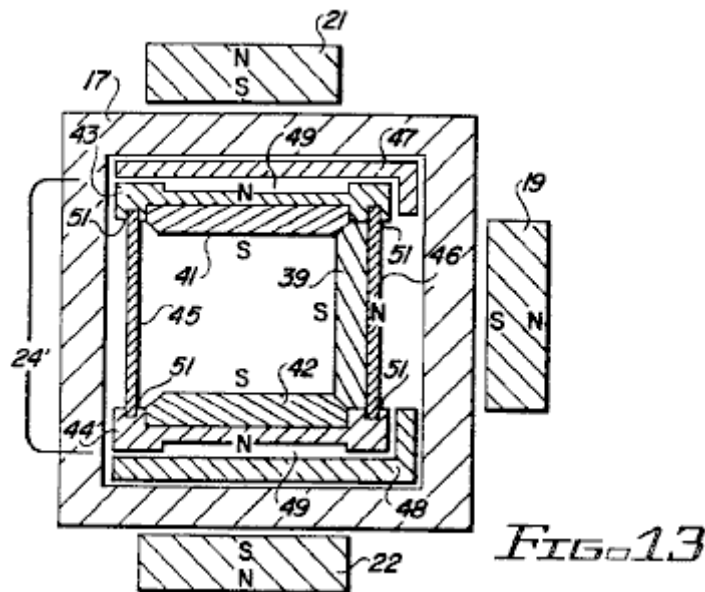

FIG. 13

Fig.13 is a cross-sectional view of the modified magnet configuration of **Fig.11** taken along line 13--13 with other features of the modified carousel structure also shown;

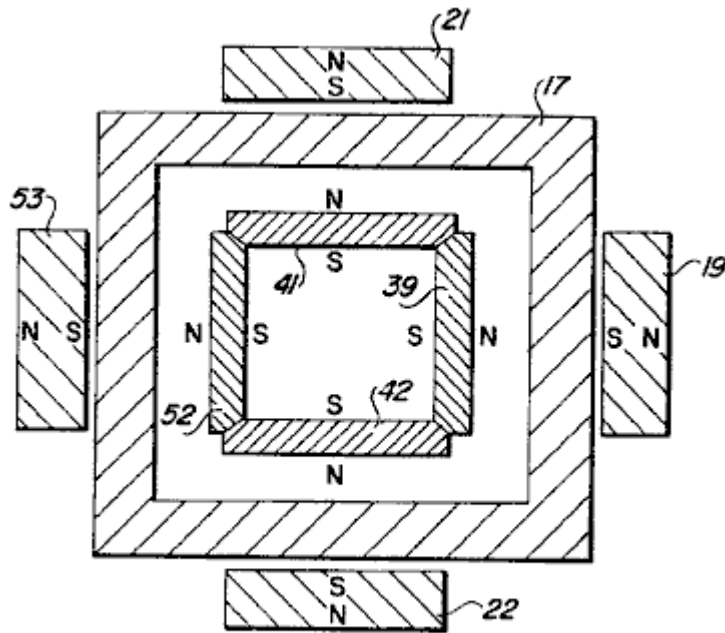

FIG. 14

Fig.14 is a modification of the carousel structure shown in **Figs. 1-13** wherein a fourth carousel magnet is positioned at each station; and

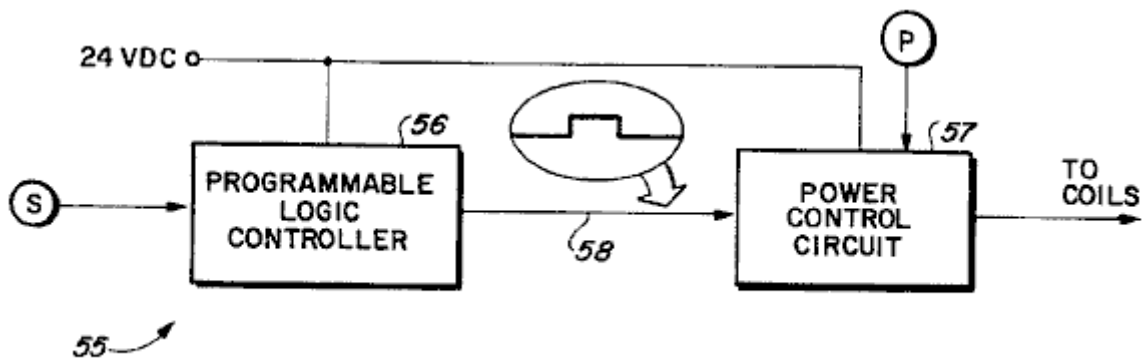
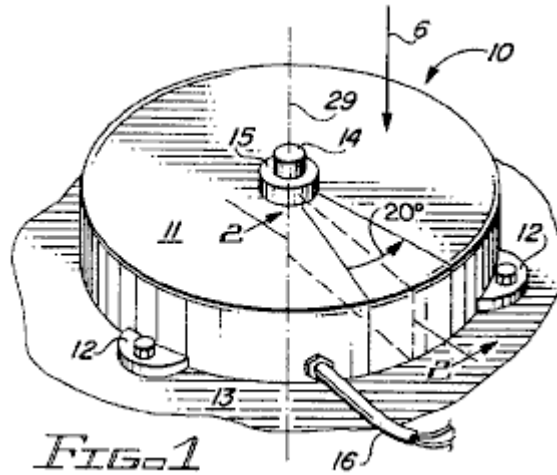

FIG. 15

Fig.15 illustrates the use of the claimed device as a pulsed direct current power source.

DESCRIPTION OF THE PREFERRED EMBODIMENT



Referring more particularly to the drawings by characters of reference, **Fig.1** shows the external proportions of a carousel electric generator **10** of the invention. As shown in **Fig.1**, generator **10** is enclosed by a housing **11** with mounting feet **12** suitable for securing the generator to a flat surface **13**. The surface **13** is preferably horizontal, as shown in **Fig.1**.

Housing **11** has the proportions of a short cylinder. A drive shaft **14** extends axially from housing **11** through a bearing **15**. The electrical output of the generator is brought out through a cable **16**.

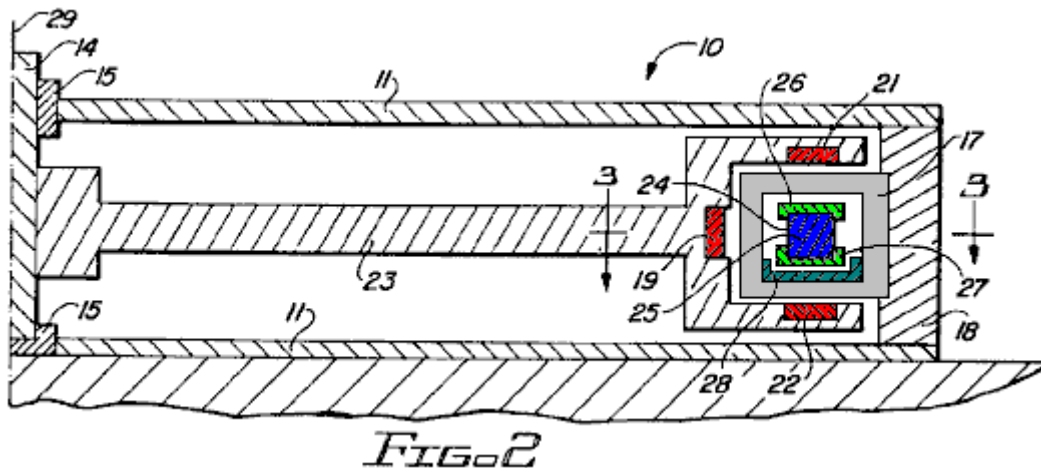

The cross-sectional view of **Fig.2** shows the active elements incorporated in one twenty degree sector of the stator and in one twenty degree sector of the rotor.

In the first implementation of the invention, there are eighteen identical stator sectors, each incorporating a winding or coil **17** wound about a rectangular coil frame or bobbin. Coil **17** is held by a stator frame **18** which may also serve as an outer wall of frame **11**.

The rotor is also divided into eighteen sectors, nine of which incorporate three permanent magnets each, including an inboard rotor magnet **19**, an upper rotor magnet **21** and a lower rotor magnet **22**. All three of these magnets have their south poles facing coil **17**, and all three are mounted directly on rotor frame **23** which is secured directly to drive shaft **14**.

The other nine sectors of the rotor are empty, i.e. they are not populated with magnets. The unpopulated sectors are alternated with the populated sectors so that adjacent populated sectors are separated by an unpopulated sector as shown in **Fig.3** and **Fig.6**.

With reference again to **Fig.2**, generator **10** also incorporates a carousel **24**. The carousel comprises nine pairs of carousel magnets **25** clamped between upper and lower retainer rings **26** and **27**, respectively. The lower retainer ring **27** rests inside an air bearing channel **28** which is secured to stator **18** inside the bobbin of coil **17**. Air passages (not shown) admit air into the space between the lower surface of ring **27** and the upper or inside

surface of channel 28. This arrangement comprises an air bearing which permits carousel 24 to rotate freely within the coils 17 about rotational axis 29 of rotor frame 23.

Carousel 24 is also divided into 18 twenty-degree sectors, including nine populated sectors interspersed with nine unpopulated sectors in an alternating sequence. Each of the nine populated sectors incorporates a pair of carousel magnets as described in the preceding paragraph.

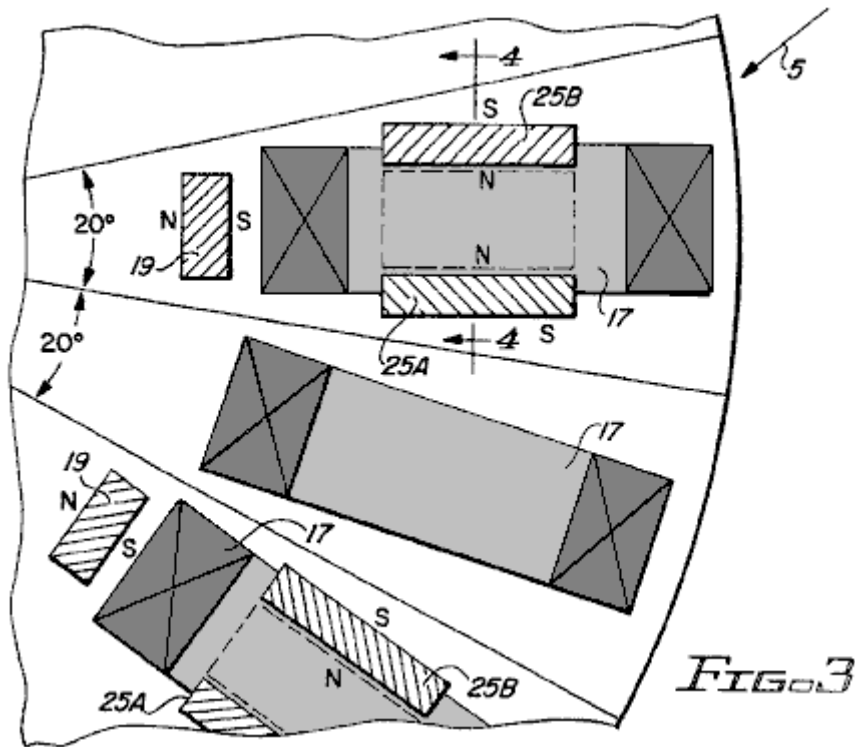

The geometrical relationship between the rotor magnets, the carousel magnets and the coils, is further clarified by Fig.3, Fig.4 and Fig.5. In each of the three figures, the centre of each populated rotor sector is shown aligned with the centre of a coil 17. Each populated carousel sector, which is magnetically locked into position with a populated rotor sector, is thus also aligned with a coil 17.

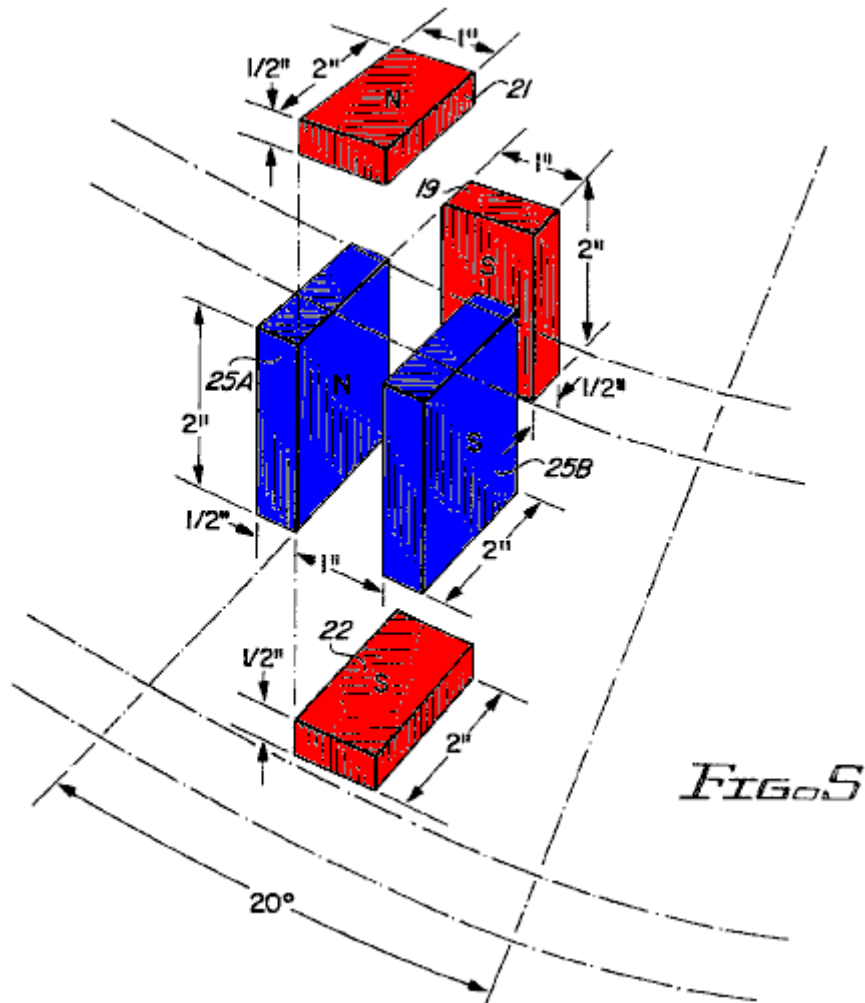

In an early implementation of the invention, the dimensions and spacings of the rotor magnets **19**, **21** and **22** and carousel magnets, **25A** and **25B** of carousel magnet pairs **25** were as shown in **Fig.5**. Each of the rotor magnets **19**, **21** and **22** measured one inch by two inches by one-half inch with north and south poles at opposite one-inch by two-inch faces. Each of the carousel magnets **25A** and **25B** measured two inches by two inches by one-half inch with north and south poles at opposite two-inch by two-inch faces. The magnets were obtained from Magnet Sales and Manufacturing, Culver City, Calif. The carousel magnets were part No.35NE2812832; the rotor magnets were custom parts of equivalent strength (MMF) but half the cross section of the carousel magnets.

Coil supports and other stationary members located within magnetic field patterns are fabricated from Delrin or Teflon plastic or equivalent materials. The use of aluminium or other metals introduce eddy current losses and in some cases excessive friction.

As shown in **Fig.5**, carousel magnets **25A** and **25B** stand on edge, parallel with each other, their north poles facing each other, and spaced one inch apart. When viewed from directly above the carousel magnets, the space between the two magnets **25A** and **25B** appears as a one-inch by two-inch rectangle. When the carousel magnet pair **25** is perfectly locked into position magnetically, upper rotor magnet **21** is directly above this one-inch by two-inch rectangle, lower rotor magnet **22** is directly below it, and their one-inch by two-inch faces are directly aligned with it, the south poles of the two magnets **21** and **22** facing each other.

In like manner, when viewed from the axis of rotation of generator **10**, the space between carousel magnets **25A** and **25B** again appears as a one-inch by two-inch rectangle, and this rectangle is aligned with the one-inch by two-inch face of magnet **19**, the south pole of magnet **19** facing the carousel magnet pair **25**.

Rotor magnets **19**, **21** and **22** are positioned as near as possible to carousel magnets **25A** and **25B** while still allowing passage for coil **17** over and around the carousel magnets and through the space between the carousel magnets and the rotor magnets.

In an electric generator, the voltage induced in the generator windings is proportional to the product of the number of turns in the winding and the rate of change of flux linkages that is produced as the winding is rotated through

the magnetic field. An examination of magnetic field patterns is therefore essential to an understanding of generator operation.

In generator **10**, magnetic flux emanating from the north poles of carousel magnets **25A** and **25B** pass through the rotor magnets and then return to the south poles of the carousel magnets. The total flux field is thus driven by the combined MMF (magnetomotive force) of the carousel and field magnets while the flux patterns are determined by the orientation of the rotor and carousel magnets.

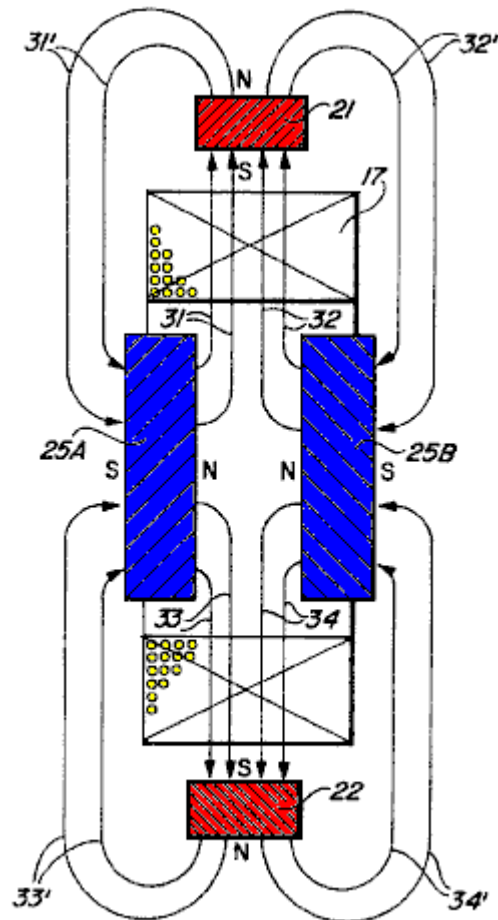

FIG. 4

The flux pattern between carousel magnets **25A** and **25B** and the upper and lower rotor magnets **21** and **22** is illustrated in **Fig.4**. Magnetic flux lines **31** from the north pole of carousel magnet **25A** extend to the south pole of upper rotor magnet **21**, pass through magnet **21** and return as lines **31'** to the south pole of magnet **25A**. Lines **33**, also from the north pole of magnet **25A** extend to the south pole of lower rotor magnet **22**, pass through magnet **22** and return to the south pole of magnet **25A** as lines **33'**. Similarly, lines **32** and **34** from the north pole of magnet **25B** pass through magnets **21** and **22**, respectively, and return as lines **32'** and **34'** to the south pole of magnet **25B**. Flux linkages produced in coil **17** by lines emanating from carousel magnet **25A** are of opposite sense from those emanating from carousel magnet **25B**. Because induced voltage is a function of the rate of change in net flux linkages, it is important to recognise this difference in sense.

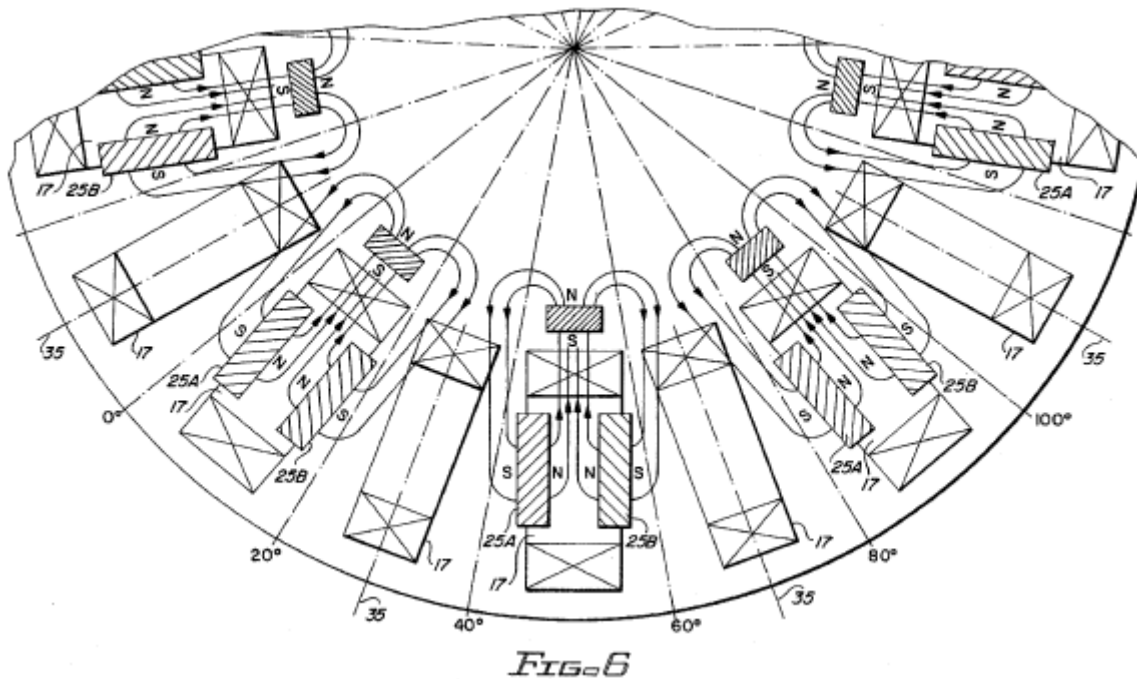
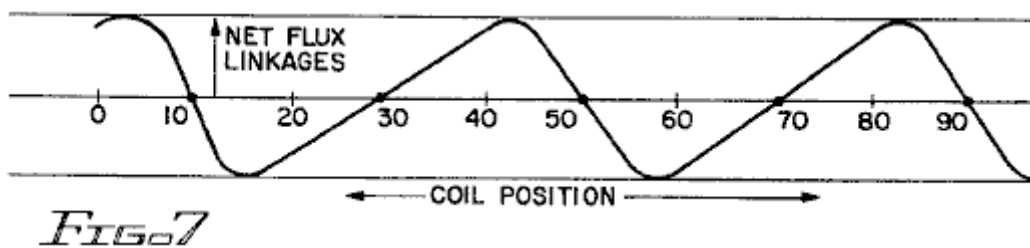

Fig.6 shows a similar flux pattern for flux between carousel magnets **25A** and **25B** and inboard rotor magnet **19**. Again the lines emanating from carousel magnet **25A** and passing through rotor magnet **19** produce flux linkages in coil **17** that are opposite in sense from those produced by lines from magnet **25B**.

The arrangement of the carousel magnets with the north poles facing each other tends to confine and channel the flux into the desired path. This arrangement replaces the function of magnetic yokes or laminations of more conventional generators.

The flux linkages produced by magnets **25A** and **25B** are opposite in sense regardless of the rotational position of coil **17** including the case where coil **17** is aligned with the carousel and rotor magnets as well as for the same coils when they are aligned with an unpopulated rotor sector.

Taking into account the flux patterns of **Fig.4** and **Fig.6** and recognising the opposing sense conditions just described, net flux linkages for a given coil **17** are deduced as shown in **Fig.7**.



In **Fig.7**, net flux linkages (coil-turns x lines) are plotted as a function of coil position in degrees. Coil position is here defined as the position of the centreline **35** of coil **17** relative to the angular scale shown in degrees in **Fig.6**. (Note that the coil is stationary and the scale is fixed to the rotor. As the rotor turns in a clockwise direction, the relative position of coil **17** progresses from zero to ten to twenty degrees etc.).

At a relative coil position of ten degrees, the coil is centred between magnets **25A** and **25B**. Assuming symmetrical flux patterns for the two magnets, the flux linkages from one magnet exactly cancel the flux linkages from the other so that net flux linkages are zero. As the relative coil position moves to the right, linkages from magnet **25A** decrease and those from magnet **25B** increase so that net flux linkages build up from zero and passes through a maximum negative value at some point between ten and twenty degrees. After reaching the negative maximum, flux linkages decrease, passing through zero at 30 degrees (where coil **17** is at the centre of an unpopulated rotor sector) and then rising to a positive maximum at some point just beyond 60 degrees. This cyclic variation repeats as the coil is subjected successively to fields from populated and unpopulated rotor sectors.

As the rotor is driven rotationally, net flux linkages for all eighteen coils are altered at a rate that is determined by the flux pattern just described in combination with the rotational velocity of the rotor. Instantaneous voltage

induced in coil 17 is a function of the slope of the curve shown in **Fig.7** and rotor velocity, and voltage polarity changes as the slope of the curve alternates between positive and negative.

It is important to note here that a coil positioned at ten degrees is exposed to a negative slope while the adjacent coil is exposed to a positive slope. The polarities of the voltages induced in the two adjacent coils are therefore opposite. For series or parallel connections of odd and even-numbered coils, this polarity discrepancy can be corrected by installing the odd and even numbered coils oppositely (odds rotated end for end relative to evens) or by reversing start and finish connections of odd relative to even numbered coils. Either of these measures will render all coil voltages additive as needed for series or parallel connections. Unless the field patterns for populated and unpopulated sectors are very nearly symmetrical, however, the voltages induced in odd and even numbered coils will have different waveforms. This difference will not be corrected by the coil reversals or reverse connections discussed in the previous paragraph. Unless the voltage waveforms are very nearly the same, circulating currents will flow between even and odd-numbered coils. These circulating currents will reduce generator efficiency.

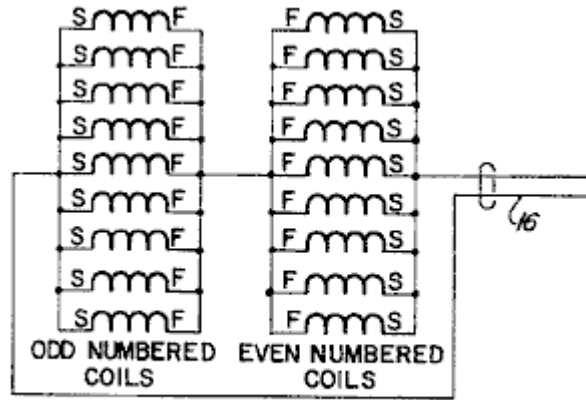

FIG. 8

To prevent such circulating currents and the attendant loss in operating efficiency for non symmetrical field patterns and unmatched voltage waveforms, the series-parallel connections of **Fig.8** may be employed in a high-current, low-voltage configuration of the generator. If the eighteen coils are numbered in sequence from one to eighteen according to position about the stator, all even-numbered coils are connected in parallel, all odd-numbered coils are connected in parallel, and the two parallel coil groups are connected in series as shown with reversed polarity for one group so that voltages will be in phase relative to output cable 16.

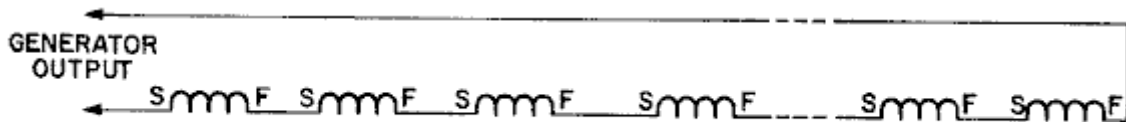

FIG. 9

For a low-current, high voltage configuration, the series connection of all coils may be employed as shown in **Fig.9**. In this case, it is only necessary to correct the polarity difference between even and odd numbered coils. As mentioned earlier, this can be accomplished by means of opposite start and finish connections for odd and even coils or by installing alternate coils reversed, end for end.

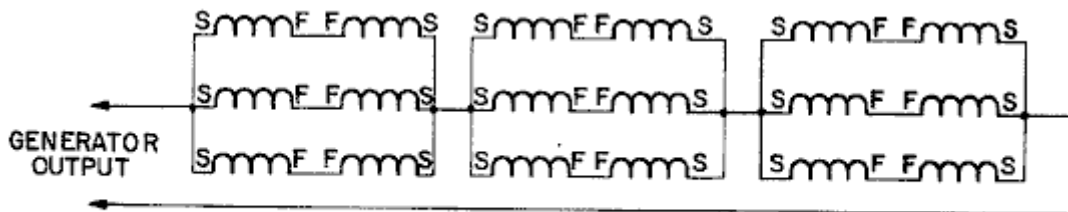

FIG. 10

For intermediate current and voltage configurations, various series-parallel connections may be employed. **Fig.10**, for example, shows three groups of six coils each connected in series. Circulating currents will be avoided so long as even-numbered coils are not connected in parallel with odd-numbered coils. Parallel connection of

series-connected odd/even pairs as shown is permissible because the waveforms of the series pairs should be very neatly matched.

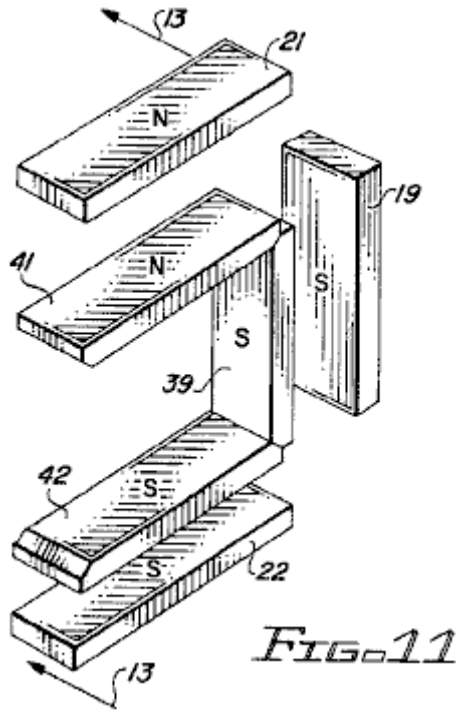

FIG. 11

In another embodiment of the invention, the two large (two-inch by two-inch) carousel magnets are replaced by three smaller magnets as shown in **Fig. 11**, **Fig. 12** and **Fig. 13**. The three carousel magnets comprise an inboard carousel magnet 39, an upper carousel magnet 41 and a lower carousel magnet 42 arranged in a U-shaped configuration that matches the U-shaped configuration of the rotor magnets 19, 21 and 22. As in the case of the first embodiment, the rotor and carousel magnets are present only in alternate sectors of the generator.

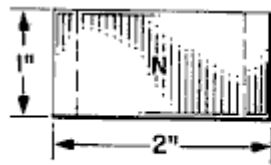

FIG. 12A

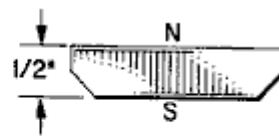

FIG. 12B

The ends of the carousel magnets are bevelled to permit a more compact arrangement of the three magnets. As shown in **Fig. 12**, each magnet measures one inch by two inches by one half inch thick. The south pole occupies the bevelled one-inch by two-inch face and the north pole is at the opposite face.

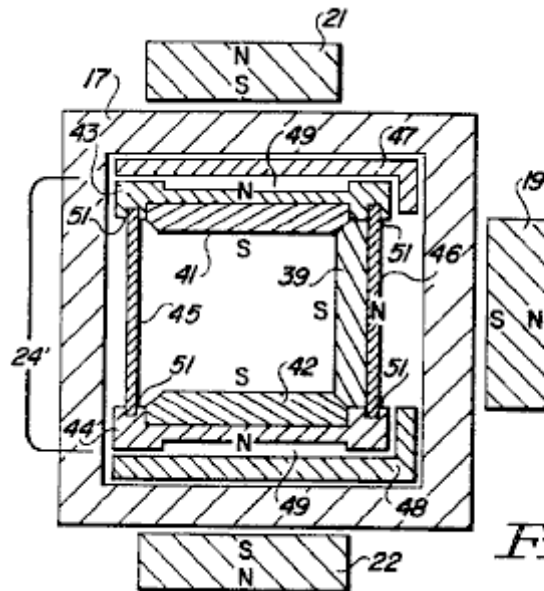

FIG. 13

The modified carousel structure **24'** as shown in **Fig.13** comprises an upper carousel bearing plate **43**, a lower carousel bearing plate **44**, an outer cylindrical wall **45** and an inner cylindrical wall **46**. The upper and lower bearing plates **43** and **44** mate with the upper and lower bearing members **47** and **48**, respectively, which are stationary and secured inside the forms of the coils **17**. Bearing plates **43** and **44** are shaped to provide air channels **49** which serve as air bearings for rotational support of the carousel **24'**. The bearing plates are also slotted to receive the upper and lower edges **51** of cylindrical walls **45** and **46**.

The modified carousel structure **24'** offers a number of advantages over the first embodiment. The matched magnet configuration of the carousel and the rotor provides tighter and more secure coupling between the carousel and the rotor. The smaller carousel magnets also provide a significant reduction in carousel weight. This was found beneficial relative to the smooth and efficient rotational support of the carousel.

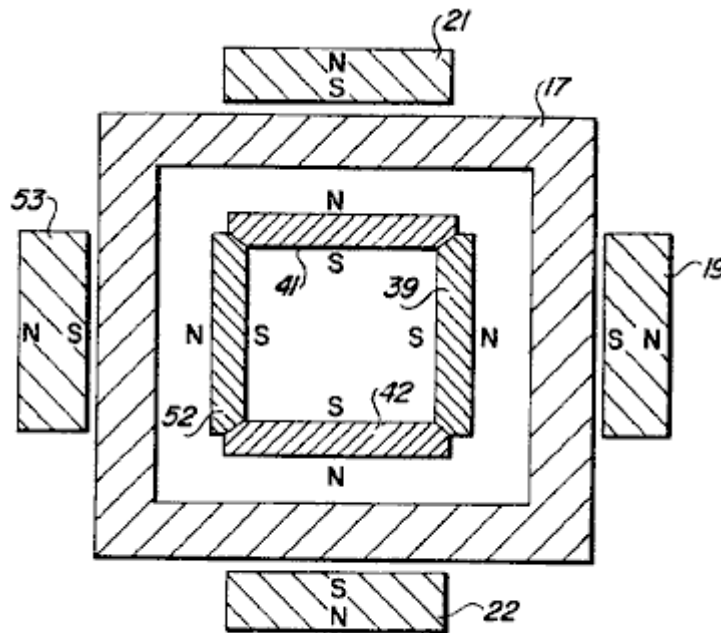

FIG. 14

The modification of the carousel structure as described in the foregoing paragraphs can be taken one step further with the addition of a fourth carousel magnet **52** at each station as shown in **Fig.14**. The four carousel magnets **39**, **41**, **42** and **52** now form a square frame with each of the magnet faces (north poles) facing a corresponding inside face of the coil **17**. Carousel magnets for this modification may again be as shown in **Fig.12**. An additional rotor magnet **53** may also be added as shown, in alignment with carousel magnet **52**. These additional modifications further enhance the field pattern and the degree of coupling between the rotor and the carousel.

The carousel electric generator of the invention is particularly well suited to high speed, high frequency operation where the high speed compensates for lower flux densities than might be achieved with a magnetic medium for routing the field through the generator coils. For many applications, such as emergency lighting, the high frequency is also advantageous. Fluorescent lighting, for example, is more efficient in terms of lumens per watt and the ballasts are smaller at high frequencies.

While the present invention has been directed toward the provision of a compact generator for specialised generator applications, it is also possible to operate the device as a motor by applying an appropriate alternating voltage source to cable **16** and coupling drive shaft **14** to a load.

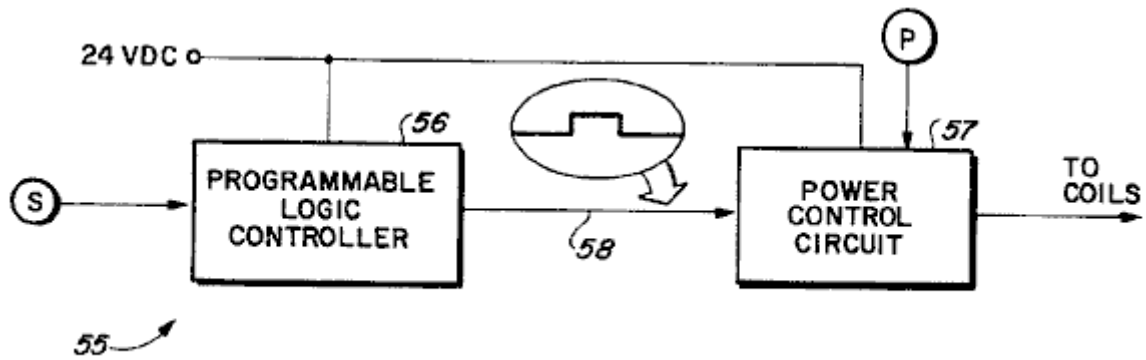

FIG. 15

It is also possible to operate the device of the invention as a motor using a pulsed direct-current power source. A control system **55** for providing such operation is illustrated in **Fig.15**. Incorporated in the control system **55** are a rotor position sensor **S**, a programmable logic controller **56**, a power control circuit **57** and a potentiometer **P**.

Based on signals received from sensor **S**, controller **56** determines the appropriate timing for coil excitation to assure maximum torque and smooth operation. This entails the determination of the optimum positions of the rotor and the carousel at the initiation and at the termination of coil excitation. For smooth operation and maximum torque, the force developed by the interacting fields of the magnets and the excited coils should be unidirectional to the maximum possible extent.

Typically, the coil is excited for only 17.5 degrees or less during each 40 degrees of rotor rotation.

The output signal **58** of controller **56** is a binary signal (high or low) that is interpreted as an ON and OFF command for coil excitation.

The power control circuit incorporates a solid state switch in the form of a power transistor or a MOSFET. It responds to the control signal **58** by turning the solid state switch ON and OFF to initiate and terminate coil excitation. Instantaneous voltage amplitude supplied to the coils during excitation is controlled by means of potentiometer **P**. Motor speed and torque are thus responsive to potentiometer adjustments.

The device is also adaptable for operation as a motor using a commutator and brushes for control of coil excitation. In this case, the commutator and brushes replace the programmable logic controller and the power control circuit as the means for providing pulsed DC excitation. This approach is less flexible but perhaps more efficient than the programmable control system described earlier.

It will now be recognised that a novel and useful generator has been provided in accordance with the stated objects of the invention, and while but a few embodiments of the invention have been illustrated and described it will be apparent to those skilled in the art that various changes and modifications may be made without departing from the spirit of the invention or from the scope of the appended claims.

Notes:

I found it a little difficult to visualise the carousel part, so the following may be helpful for some people. The "carousel" is formed from two circular plastic channels like this:

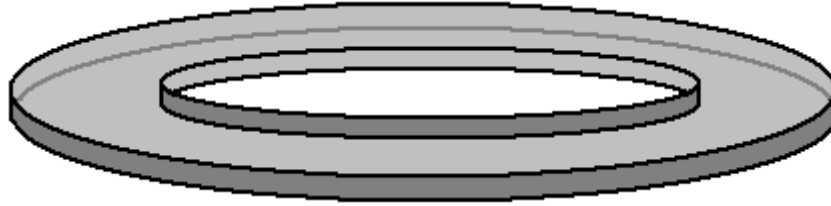

These channels are placed, one below and one above, nine pairs of carousel magnets (coloured blue in some of the patent diagrams shown above). Each carousel magnet sits in the lower channel:

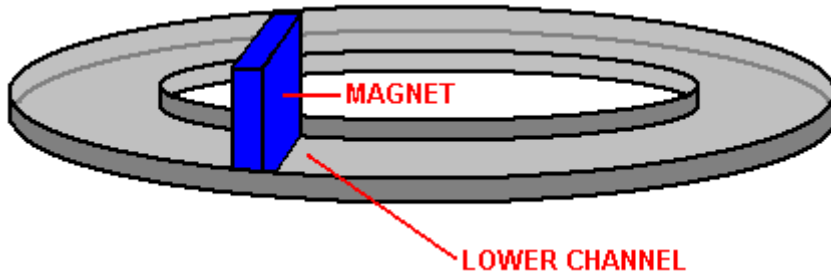

And these magnets are secured as a unit by an identical plastic channel inverted and placed on top of the magnet set:

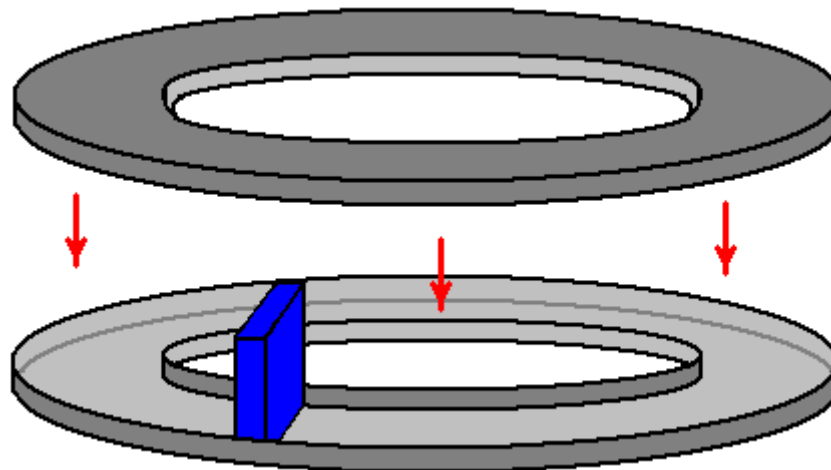

And this ring assembly of magnets spins inside the wire coils used to generate the electrical output. The ring spins inside the coils because the nine pairs of magnets in the ring, lock in place opposite the matching nine pairs of magnets in the rotor and the magnetic force and rotor rotation causes the ring to spin inside the coils.

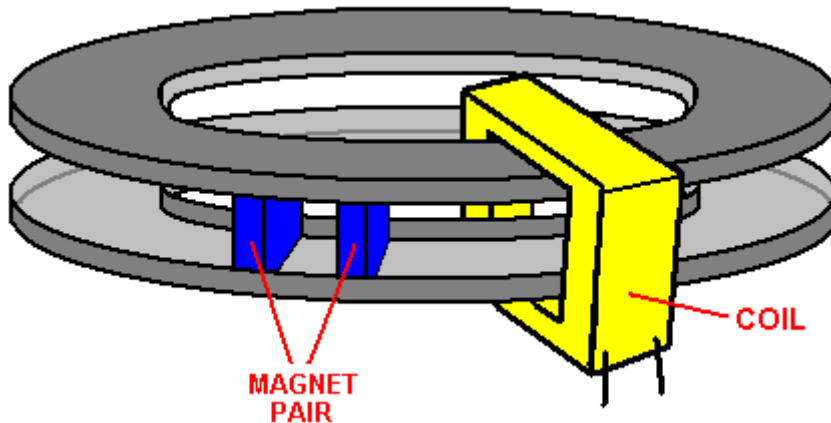

OPTICAL GENERATOR OF AN ELECTROSTATIC FIELD HAVING LONGITUDINAL OSCILLATION AT LIGHT FREQUENCIES FOR USE IN AN ELECTRICAL CIRCUIT

Please note that this is a re-worded excerpt from this patent. It describes a gas-filled tube which allows many standard 40-watt fluorescent tubes to be powered using less than 1-watt of power each.

ABSTRACT

An Optical generator of an electrostatic field at light frequencies for use in an electrical circuit, the generator having a pair of spaced-apart electrodes in a gas-filled tube of quartz glass or similar material with at least one capacitor cap or plate adjacent to one electrode and a dielectric filled container enclosing the tube, the generator substantially increasing the electrical efficiency of the electrical circuit.

BACKGROUND OF THE INVENTION

This invention relates to improved electrical circuits, and more particularly to circuits utilising an optical generator of an electrostatic field at light frequencies.

The measure of the efficiency of an electrical circuit may broadly be defined as the ratio of the output energy in the desired form (such as light in a lighting circuit) to the input electrical energy. Up to now, the efficiency of many circuits has not been very high. For example, in a lighting circuit using 40 watt fluorescent lamps, only about 8.8 watts of the input energy per lamp is actually converted to visible light, thus representing an efficiency of only about 22%. The remaining 31.2 watts is dissipated primarily in the form of heat.

It has been suggested that with lighting circuits having fluorescent lamps, increasing the frequency of the applied current will raise the overall circuit efficiency. While at an operating frequency of 60 Hz, the efficiency is 22%, if the frequency is raised to 1 Mhz, the circuit efficiency would only rise to some 25.5%. Also, if the input frequency were raised to 10 Ghz, the overall circuit efficiency would only be 35%.

SUMMARY OF THE PRESENT INVENTION

The present invention utilises an optical electrostatic generator which is effective for producing high frequencies in the visible light range of about 10^{14} to 10^{23} Hz. The operation and theory of the optical electrostatic generator has been described and discussed in my co-pending application serial No. 5,248, filed on 23rd January 1970. As stated in my co-pending application, the present optical electrostatic generator does not perform in accordance with the accepted norms and standards of ordinary electromagnetic frequencies.

The optical electrostatic generator as utilised in the present invention can generate a wide range of frequencies between several Hertz and those in the light frequency. Accordingly, it is an object of the present invention to provide improved electrical energy circuits utilising my optical electrostatic generator, whereby the output energy in the desired form will be substantially more efficient than possible to date, using standard circuit techniques and equipment. It is a further object of the present invention to provide such a circuit for use in fluorescent lighting or other lighting circuits. It is also an object of the present invention to provide a circuit with may be used in conjunction with electrostatic precipitators for dust and particle collection and removal, as well as many other purposes.

DESCRIPTION OF THE DRAWINGS

Fig.1 is a schematic layout showing an optical electrostatic generator of the present invention, utilised in a lighting circuit for fluorescent lamps:

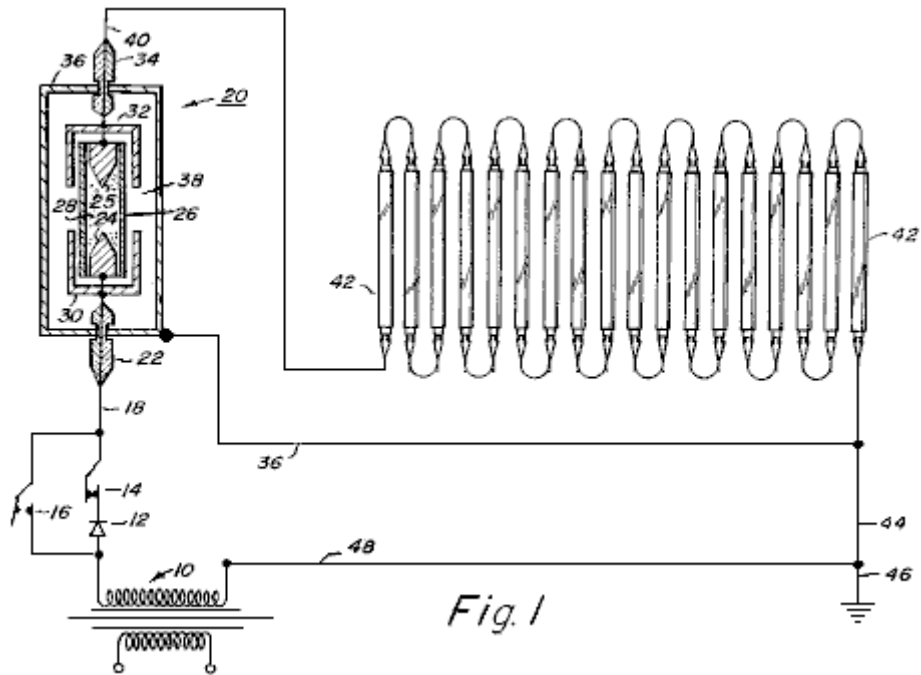

Fig. 1

Fig. 2 is a schematic layout of a high-voltage circuit incorporating an optical electrostatic generator:

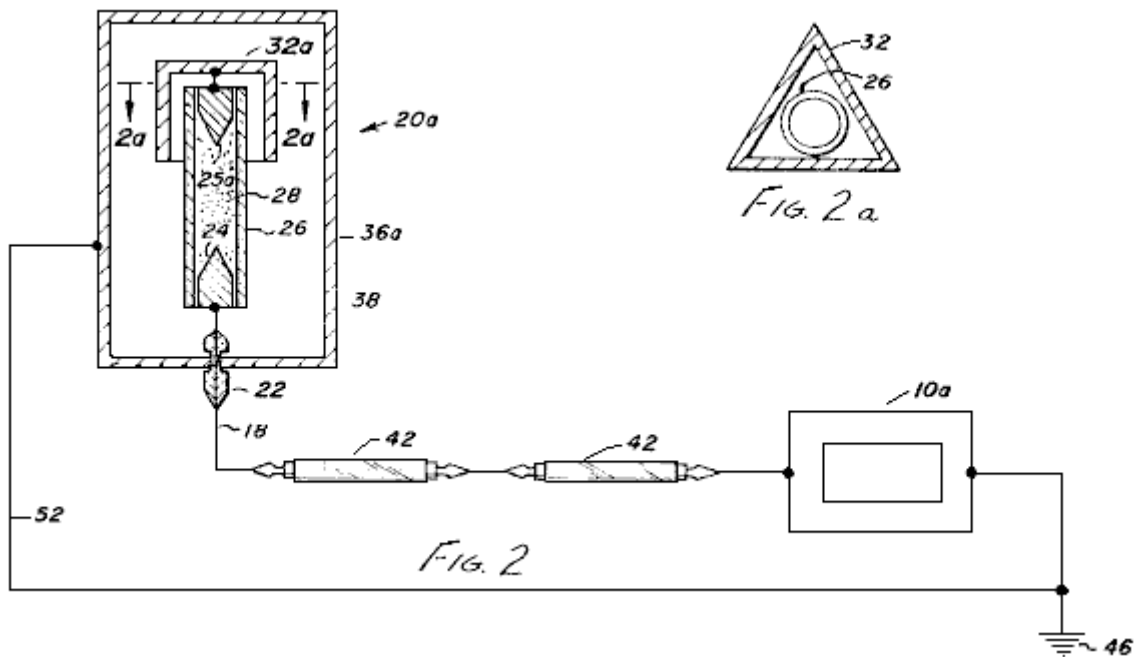
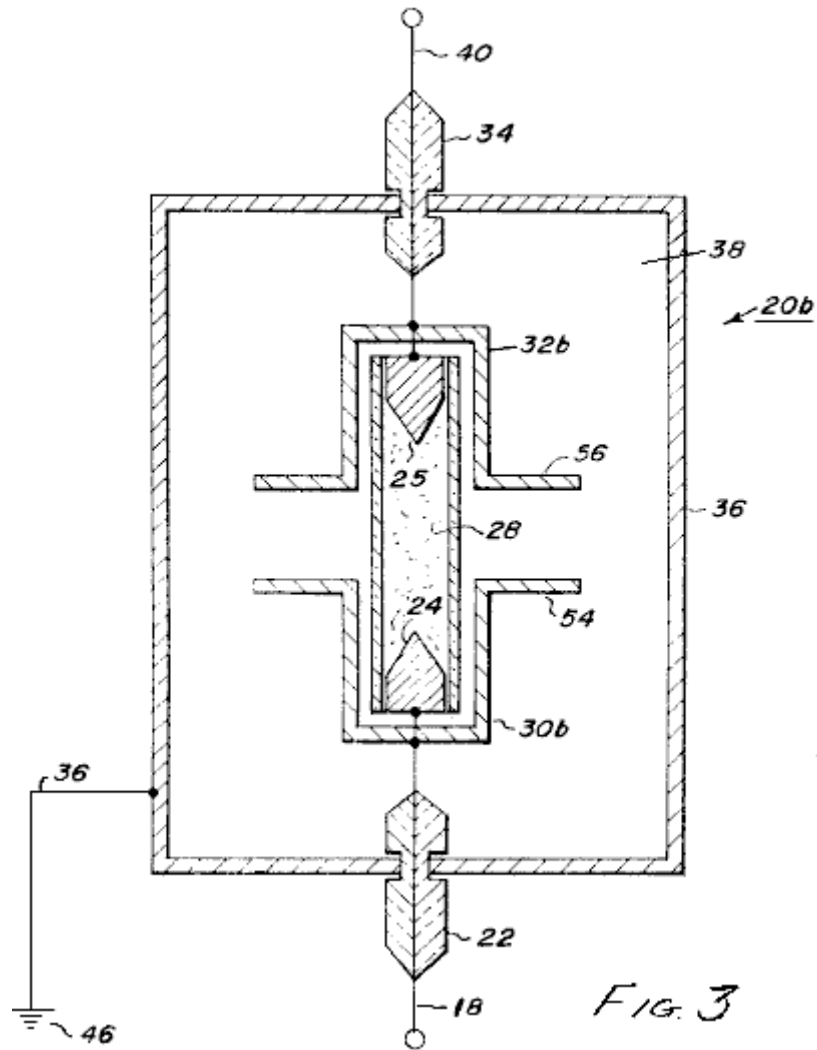

Fig. 2 a

Fig. 2

Fig. 2A is a sectional view through a portion of the generator and

Fig. 3 is a schematic sectional view showing an optical electrostatic generator in accordance with the present invention, particularly for use in alternating current circuits, although it may also be used in direct current circuits:



DESCRIPTION OF THE ILLUSTRATED EMBODIMENTS

Referring to the drawings and to **Fig.1** in particular, a low voltage circuit utilising an optical electrostatic generator is shown. As shown in **Fig.1**, a source of alternating current electrical energy **10**, is connected to a lighting circuit. Connected to one tap of the power source **10** is a rectifier **12** for utilisation when direct current is required. The illustrated circuit is provided with a switch **14** which may be opened or closed depending on whether AC or DC power is used. Switch **14** is opened and a switch **16** is closed when AC is used. With switch **14** closed and switch **16** open, the circuit operates as a DC circuit.

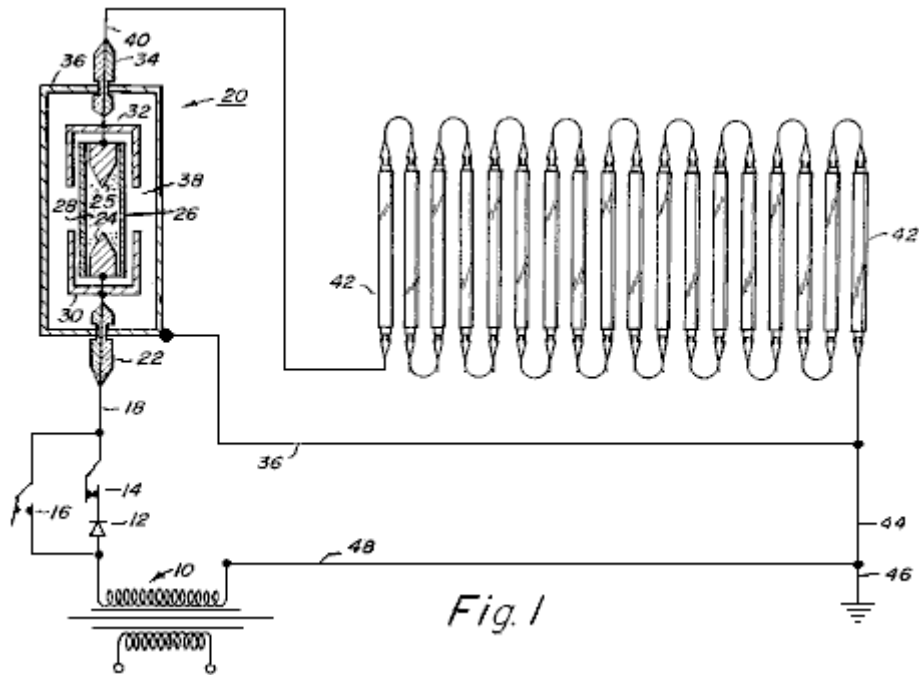

Fig. 1

Extending from switches 14 and 16 is conductor 18 which is connected to an optical electrostatic generator 20. Conductor 18 is passed through an insulator 22 and connected to an electrode 24. Spaced from electrode 24 is a second electrode 25. Enclosing electrodes 24 and 25, which preferably are made of tungsten or similar material, is a quartz glass tube 26 which is filled with an ionisable gas 28 such as xenon or any other suitable ionisable gas such as argon, krypton, neon, nitrogen or hydrogen, as well as the vapour of metals such as mercury or sodium.

Surrounding each end of tube 26 and adjacent to electrodes 24 and 25, are capacitor plates 30 and 32 in the form of caps. A conductor is connected to electrode 25 and passed through a second insulator 34. Surrounding the tube, electrodes and capacitor caps is a metal envelope in the form of a thin sheet of copper or other metal such as aluminium. Envelope 36 is spaced from the conductors leading into and out of the generator by means of insulators 22 and 34. Envelope 36 is filled with a dielectric material such as transformer oil, highly purified distilled water, nitro-benzene or any other suitable liquid dielectric. In addition, the dielectric may be a solid such as ceramic material with relatively small molecules.

A conductor 40 is connected to electrode 25, passed through insulator 34 and then connected to a series of fluorescent lamps 42 which are connected in series. It is the lamps 42 which will be the measure of the efficiency of the circuit containing the optical electrostatic generator 20. A conductor 44 completes the circuit from the fluorescent lamps to the tap of the source of electrical energy 10. In addition, the circuit is connected to a ground 46 by another conductor 48. Envelope 36 is also grounded by lead 50 and in the illustrated diagram, lead 50 is connected to the conductor 44.

The capacitor caps or plates 30 and 32, form a relative capacitor with the discharge tube. When a high voltage is applied to the electrode of the discharge tube, the ions of gas are excited and brought to a higher potential than their environment, i.e. the envelope and the dielectric surrounding it. At this point, the ionised gas in effect becomes one plate of a relative capacitor in co-operation with the capacitor caps or plates 30 and 32.

When this relative capacitor is discharged, the electric current does not decrease as would normally be expected. Instead, it remains substantially constant due to the relationship between the relative capacitor and an absolute capacitor which is formed between the ionised gas and the spaced metal envelope 36. An oscillation effect occurs in the relative capacitor, but the electrical condition in the absolute capacitor remains substantially constant.

As also described in the co-pending application serial No. 5,248, there is an oscillation effect between the ionised gas in the discharge lamp and the metallic envelope 36 will be present if the capacitor caps are eliminated, but the efficiency of the electrostatic generator will be substantially decreased.

The face of the electrode can be any desired shape. However, a conical point of 60° has been found to be satisfactory and it is believed to have an influence on the efficiency of the generator.

In addition, the type of gas selected for use in tube 26, as well as the pressure of the gas in the tube, also affect the efficiency of the generator, and in turn, the efficiency of the electrical circuit.

To demonstrate the increased efficiency of an electrical circuit utilising the optical electrostatic generator of the present invention as well as the relationship between gas pressure and electrical efficiency, a circuit similar to that shown in **Fig.1** may be used with 100 standard 40 watt, cool-white fluorescent lamps connected in series. The optical electrostatic generator includes a quartz glass tube filled with xenon, with a series of different tubes being used because of the different gas pressures being tested.

Table 1 shows the data to be obtained relating to the optical electrostatic generator. **Table 2** shows the lamp performance and efficiency for each of the tests shown in **Table 1**. The following is a description of the data in each of the columns of **Tables 1 and 2**.

Column	Description
B	Gas used in discharge tube
C	Gas pressure in tube (in torrs)
D	Field strength across the tube (measured in volts per cm. of length between the electrodes)
E	Current density (measured in microamps per sq. mm. of tube cross-sectional area)
F	Current (measured in amps)
G	Power across the tube (calculated in watts per cm. of length between the electrodes)
H	Voltage per lamp (measured in volts)
K	Current (measured in amps)
L	Resistance (calculated in ohms)
M	Input power per lamp (calculated in watts)
N	Light output (measured in lumens)

Table 1

A Test No.	B Type of discharge lamp	Optical	Generator	Section	F Current (A)	G Power str. across lamp (W/cm.)
		C Pressure of Xenon (Torr)	D Field strength across lamp (V/cm)	E Current density (A/sq.mm)		
1	Mo elec	-	-	-	-	-
2	Xe	0.01	11.8	353	0.1818	2.14
3	Xe	0.10	19.6	353	0.1818	3.57
4	Xe	1.00	31.4	353	0.1818	5.72
5	Xe	10.00	47.2	353	0.1818	8.58
6	Xe	20.00	55.1	353	0.1818	10.02
7	Xe	30.00	62.9	353	0.1818	11.45
8	Xe	40.00	66.9	353	0.1818	12.16
9	Xe	60.00	70.8	353	0.1818	12.88
10	Xe	80.00	76.7	353	0.1818	13.95
11	Xe	100.00	78.7	353	0.1818	14.31
12	Xe	200.00	90.5	353	0.1818	16.46
13	Xe	300.00	100.4	353	0.1818	18.25
14	Xe	400.00	106.3	353	0.1818	19.32
15	Xe	500.00	110.2	353	0.1818	20.04
16	Xe	600.00	118.1	353	0.1818	21.47
17	Xe	700.00	120.0	353	0.1818	21.83
18	Xe	800.00	122.8	353	0.1818	22.33
19	Xe	900.00	125.9	353	0.1818	22.90
20	Xe	1,000.00	127.9	353	0.1818	23.26
21	Xe	2,000.00	149.6	353	0.1818	27.19
22	Xe	3,000.00	161.4	353	0.1818	29.35
23	Xe	4,000.00	173.2	353	0.1818	31.49
24	Xe	5,000.00	179.1	353	0.1818	32.56

Table 2

Fluorescent Lamp Section					
A	H	K	L	M	N
Test No.	Voltage	Current	Resistance	Input Energy	Light Output
	(Volts)	(Amps)	(Ohms)	(Watts)	(Lumen)
1	220	0.1818	1,210	40.00	3,200
2	218	0.1818	1,199	39.63	3,200
3	215	0.1818	1,182	39.08	3,200
4	210	0.1818	1,155	38.17	3,200
5	200	0.1818	1,100	36.36	3,200
6	195	0.1818	1,072	35.45	3,200
7	190	0.1818	1,045	34.54	3,200
8	182	0.1818	1,001	33.08	3,200
9	175	0.1818	962	31.81	3,200
10	162	0.1818	891	29.45	3,200
11	155	0.1818	852	28.17	3,200
12	130	0.1818	715	23.63	3,200
13	112	0.1818	616	20.36	3,200
14	100	0.1818	550	18.18	3,200
15	85	0.1818	467	15.45	3,200
16	75	0.1818	412	13.63	3,200
17	67	0.1818	368	12.18	3,200
18	60	0.1818	330	10.90	3,200
19	53	0.1818	291	9.63	3,200
20	50	0.1818	275	9.09	3,200
21	23	0.1818	126	4.18	3,200
22	13	0.1818	71	2.35	3,200
23	8	0.1818	44	1.45	3,200
24	5	0.1818	27	0.90	3,200

The design of a tube construction for use in the optical electrostatic generator of the type used in **Fig.1**, may be accomplished by considering the radius of the tube, the length between the electrodes in the tube and the power across the tube.

If **R** is the minimum inside radius of the tube in centimetres, **L** the minimum length in centimetres between the electrodes, and **W** the power in watts across the lamp, the following formula can be obtained from **Table 1**:

$$R = (\text{Current [A]} / \text{Current Density [A/sq.mm]}) / \pi$$

$$L = 8R$$

$$W = L[V/cm] \times A$$

For example, for Test No. 18 in Table 1:
 The current is 0.1818 A,
 The current density 0.000353 A/sq.mm and
 The Voltage Distribution is 122.8 V/cm; therefore

$$R = (0.1818 / 0.000353)^2 / 3.14 = 12.80 \text{ mm.}$$

$$L = 8 \times R = 8 \times 12.8 = 102.4 \text{ mm (10.2 cm.)}$$

$$W = 10.2 \times 122.8 \times 0.1818 = 227.7 \text{ VA or 227.7 watts}$$

The percent efficiency of operation of the fluorescent lamps in Test No. 18 can be calculated from the following equation:

$$\% \text{ Efficiency} = (\text{Output Energy}/\text{Input energy}) \times 100$$

Across a single fluorescent lamp, the voltage is 60 volts and the current is 0.1818 amps therefore the input energy to the lamp **42** is 10.90 Watts. The output of the fluorescent lamp is 3,200 lumens which represents 8.8 Watts power of light energy. Thus, the one fluorescent lamp is operating at 80.7% efficiency under these conditions.

However, when the optical generator is the same as described for Test No. 18 and there are 100 fluorescent lamps in series in the circuit, the total power input is 227.7 watts for the optical generator and 1,090 watts for 100 fluorescent lamps, or a total of 1,318 watts. The total power input normally required to operate the 100 fluorescent lamps in a normal circuit would be $100 \times 40 = 4,000$ watts. So by using the optical generator in the circuit, about 2,680 watts of energy is saved.

Table 1 is an example of the functioning of this invention for a particular fluorescent lamp (40 watt cool white). However, similar data can be obtained for other lighting applications, by those skilled in the art.

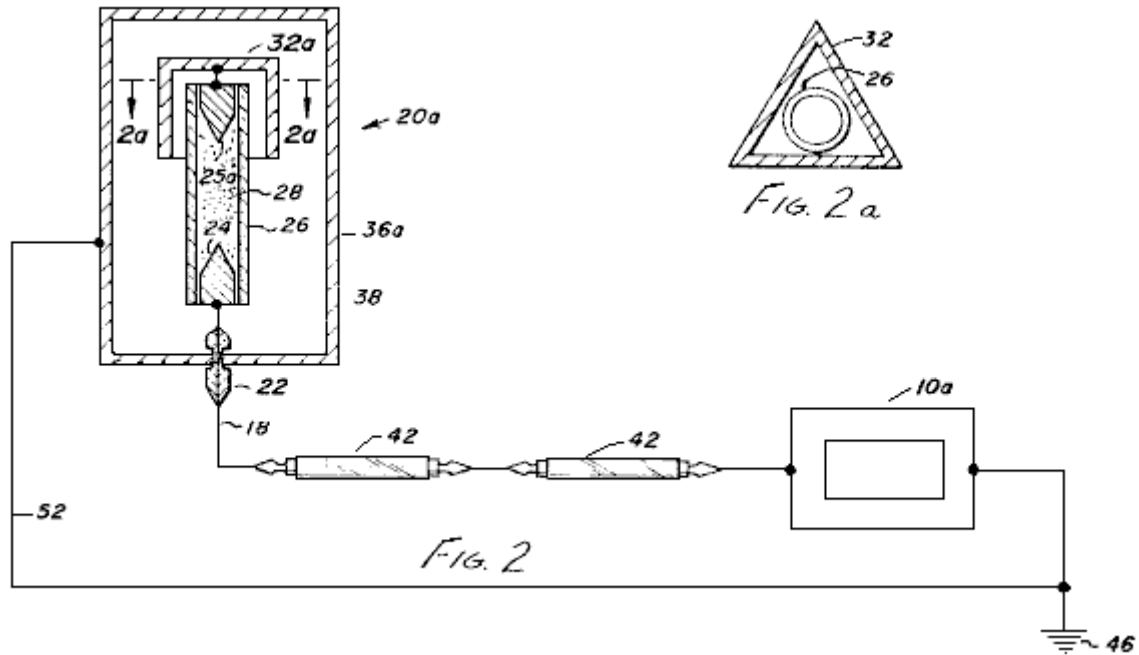

In **Fig.2**, a circuit is shown which uses an optical electrostatic generator **20a**, similar to generator **20** of **Fig.1**. In generator **20**, only one capacitor cap **32a** is used and it is preferably of triangular cross-sectional design. In addition, the second electrode **25a** is connected directly back into the return conductor **52**, similar to the arrangement shown in my co-pending application serial No. 5,248, filed 23rd January 1970.

This arrangement is preferably for very high voltage circuits and the generator is particularly suited for DC usage.

In **Fig.2**, common elements have received the same numbers which were used in **Fig.1**.

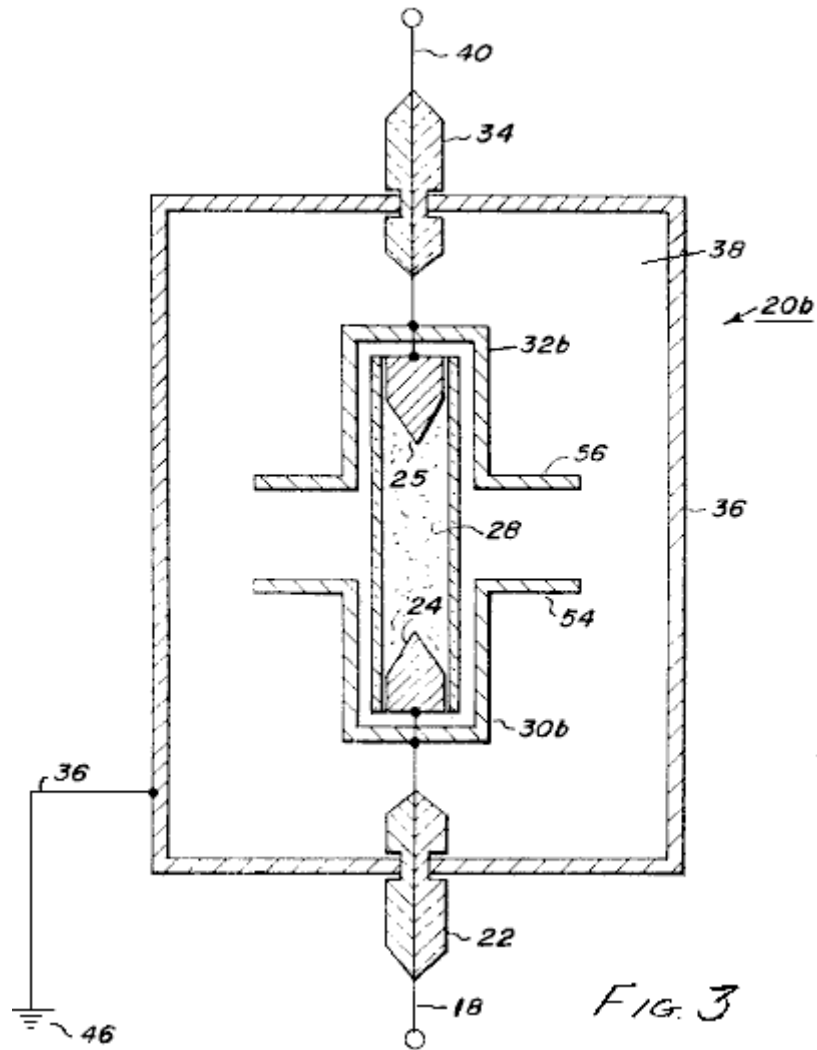

In **Fig.3**, still another embodiment of an optical electrostatic generator **20b** is shown. This generator is particularly suited for use with AC circuits. In this embodiment, the capacitor plates **30b** and **32b** have flanges **54** and **56** which extend outwards towards the envelope **36**. While the utilisation of the optical electrostatic generator has been described in use in a fluorescent lighting circuit, it is to be understood that many other types of circuits may be used. For example, the high-voltage embodiment may be used in a variety of circuits such as flash lamps, high-speed controls, laser beams and high-energy pulses. The generator is also particularly usable in a circuit including electrostatic particle precipitation in air pollution control devices, chemical synthesis in electrical discharge systems such as ozone generators and charging means for high-voltage generators of the Van de Graff type, as well as particle accelerators. To those skilled in the art, many other uses and circuits will be apparent.

HAROLD COLMAN and RONALD SEDDON-GILLESPIE

GB Patent GB 763,062

5th December 1956

Inventors: Harold Colman and Ronald Seddon-Gillespie

APPARATUS FOR PRODUCING AN ELECTRIC CURRENT

This patent shows the details of a lightweight device which can produce electricity using a self-powered electromagnet and chemical salts. The working life of the device before needing a recharge is estimated at some seventy years. The operation is controlled by a transmitter which bombards the chemical sample with 300 MHz radio waves. This produces radioactive emissions from the chemical mixture for a period of one hour maximum, so the transmitter needs to be run for fifteen to thirty seconds once every hour. The chemical mixture is shielded by a lead screen to prevent harmful radiation reaching the user. The output from the tiny device described is estimated to be some 10 amps at 100 to 110 volts DC.

DESCRIPTION

This invention relates to a new apparatus for producing electric current the apparatus being in the form of a completely novel secondary battery. The object of this invention is to provide apparatus of the above kind which is considerably lighter in weight than, and has an infinitely greater life than a known battery or similar characteristics and which can be re-activated as and when required in a minimum of time.

According to the present invention we provide apparatus comprising a generator unit which includes a magnet, a means for suspending a chemical mixture in the magnetic field, the mixture being composed of elements whose nuclei becomes unstable as a result of bombardment by short waves so that the elements become radio-active and release electrical energy, the mixture being mounted between, and in contact with, a pair of different metals such as copper and zinc, a capacitor mounted between those metals, a terminal electrically connected to each of the metals, means for conveying the waves to the mixture and a lead shield surrounding the mixture to prevent harmful radiation from the mixture.

The mixture is preferably composed of the elements Cadmium, Phosphorus and Cobalt having Atomic Weights of 112, 31 and 59 respectively. The mixture, which may be of powdered form, is mounted in a tube of non-conducting, high heat resistivity material and is compressed between granulated zinc at one end of the tube and granulated copper at the other end, the ends of the tube being closed by brass caps and the tube being carried in a suitable cradle so that it is located between the poles of the magnet. The magnet is preferably an electro-magnet and is energised by the current produced by the unit.

The means for conveying the waves to the mixture may be a pair of antennae which are exactly similar to the antennae of the transmitter unit for producing the waves, each antenna projecting from and being secured to the brass cap at each end of the tube.

The transmitter unit which is used for activating the generator unit may be of any conventional type operating on ultra-shortwave and is preferably crystal controlled at the desired frequency.

DESCRIPTION OF THE DRAWINGS

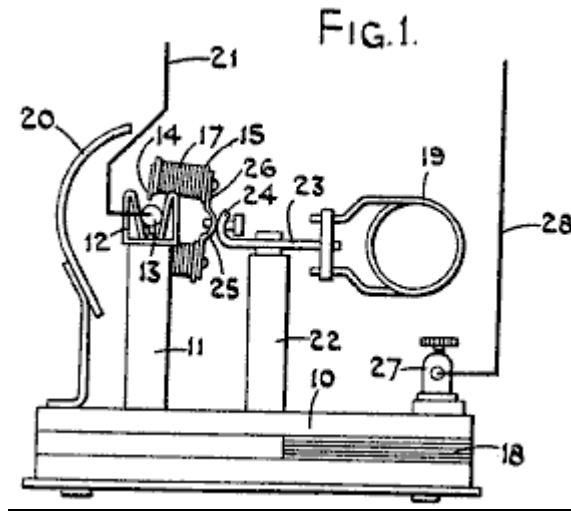

Fig.1 is a side elevation of one form of the apparatus.

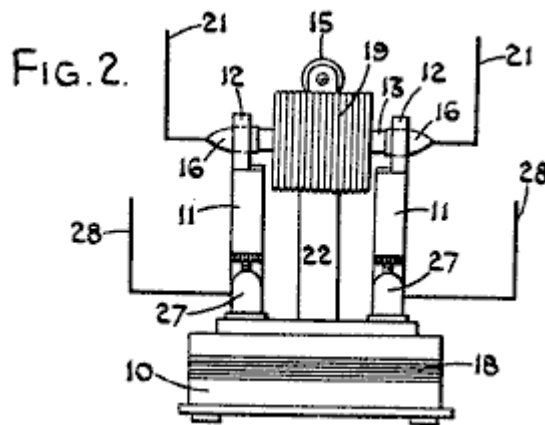

Fig.2 is a view is an end elevation

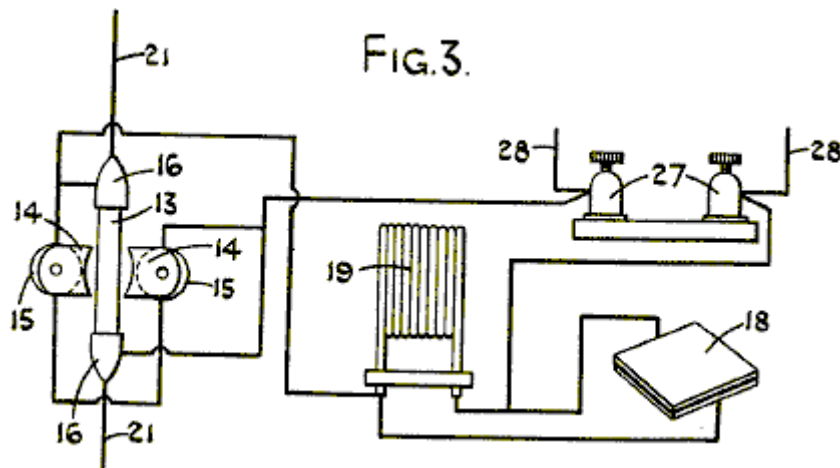

Fig.3 is a schematic circuit diagram.

In the form of our invention illustrated, the generator unit comprises a base 10 upon which the various components are mounted. This base 10, having projecting upwards from it a pair of arms 11, which form a cradle housing 12 for a quartz tube 13, the cradle 12 preferably being made of spring material so that the tube 13 is firmly, yet removably held in position. The arms 11 are positioned relative to the poles 14 of an electromagnet 15 so that the tube 13 is located immediately between the poles of the magnet so as to be in the strongest magnetic field created by the electromagnet. The magnet serves to control the alpha and beta rays emitted by the cartridge when it is in operation.

The ends of the quartz tube **13** are each provided with a brass cap **16**, and these caps **16** are adapted to engage within the spring cradles **12** and the coils **17** associated with the magnet being so arranged that if the base **10** of the unit is in a horizontal plane, the poles **14** of the magnet are in a substantially vertical plane.

Also connected across the cradles is a lead capacitor **18** which may conveniently be housed in the base **10** of the unit and connected in parallel with this capacitor **18** is a suitable high frequency inductance coil **19**. The unit is provided with a lead shield **20** so as to prevent harmful radiation from the quartz tube as will be described later.

The quartz tube **13** has mounted in it, at one end, a quantity of granulated copper which is in electrical contact with the brass cap **16** at that end of the tube. Also mounted within the tube and in contact with the granulated copper is a chemical mixture which is in powdered form and which is capable of releasing electrical energy and which becomes radioactive when subjected to bombardment by ultra-short radio waves.

Mounted in the other end of the tube, and in contact with the other end of the powdered chemical mixture is a quantity of granulated zinc which is itself in contact with the brass cap on this end of the tube, the arrangement being that the chemical mixture is compressed between the granulated copper and the granulated zinc.

Projecting outwards from each brass cap **16**, and electrically connected to them, is an antenna **21**. Each antenna **21** corresponding exactly in dimension, shape and electrical characteristics to the antenna associated with a transmitter unit which is to produce the ultra shortwaves mentioned earlier.

The electromagnet **15** is conveniently carried by a centrally positioned pillar **22** which is secured to the base **10**. At the upper end of pillar **22** there is a cross-bar **23**, which has the high frequency coil **19** attached to one end of it. The other end of the cross-bar **23** is bent around into the curved shape as shown at **24** and is adapted to bear against a curved portion **25** of the base **26** of the electromagnet **15**. A suitable locking device is provided for holding the curved portions **24** and **25** in the desired angular position, so that the position of the poles **14** of the electromagnet can be adjusted about the axis of the quartz tube **13**.

The transmitter unit is of any suitable conventional type for producing ultra shortwaves and may be crystal controlled to ensure that it operates at the desired frequency with the necessity of tuning. If the transmitter is only required to operate over a short range, it may conveniently be battery powered but if it is to operate over a greater range, then it may be operated from a suitable electrical supply such as the mains. If the transmitter is to be tuned, then the tuning may be operated by a dial provided with a micrometer vernier scale so that the necessary tuning accuracy may be achieved.

The mixture which is contained within the quartz tube is composed of the elements Cadmium, Phosphorus and Cobalt, having atomic weights 112, 31 and 59 respectively. Conveniently, these elements may be present in the following compounds, and where the tube is to contain thirty milligrams of the mixture, the compounds and their proportions by weight are:

1 Part of $\text{Co}(\text{No}_3)_2 \cdot 6\text{H}_2\text{O}$
2 Parts of CdCl_2
3 Parts of $3\text{Ca}(\text{Po}_3)_2 + 10\text{C}$.

The cartridge which consists of the tube **13** with the chemical mixture in it is preferably composed of a number of small cells built up in series. In other words, considering the cartridge from one end to the other, at one end and in contact with the brass cap, there would be a layer of powdered copper, then a layer of the chemical mixture, then a layer of powdered zinc, a layer of powdered copper, etc. with a layer of powdered zinc in contact with the brass cap at the other end of the cartridge. With a cartridge some forty five millimetres long and five millimetres diameter, some fourteen cells may be included.

The cradles **12** in which the brass caps **16** engage, may themselves form terminals from which the output of the unit may be taken. Alternatively, a pair of terminals **27** may be connected across the cradles **12**, these terminals **27** being themselves provided with suitable antennae **28**, which correspond exactly in dimensions, shape and electrical characteristics to the antennae associated with the transmitter, these antennae **28**, replacing the antennae **21**.

In operation with the quartz tube containing the above mixture located between the granulated copper and the granulated zinc and with the tube itself in position between the poles of the magnet, the transmitter is switched on and the ultra shortwaves coming from it are received by the antennae mounted at each end of the tube and in contact with the copper and zinc respectively, the waves being thus passed through the copper and zinc and through the mixture so that the mixture is bombarded by the short waves and the Cadmium, Phosphorus and Cobalt associated with the mixture become radioactive and release electrical energy which is transmitted to the granulated copper and granulated zinc, causing a current to flow between them in a similar manner to the current

flow produced by a thermo couple. It has been established that with a mixture having the above composition, the optimum release of energy is obtained when the transmitter is operating at a frequency of 300 MHz.

The provision of a quartz tube is necessary for the mixture evolves a considerable amount of heat while it is reacting to the bombardment of the short waves. It is found that the tube will only last for one hour and that the tube will become discharged after an hours operation, that is to say, the radioactiveness of the tube will only last for one hour and it is therefore necessary, if the unit is to be run continuously, for the transmitter to be operated for a period of some fifteen to thirty seconds duration once every hour.

With a quartz tube having an overall length of some forty five millimetres and an inside diameter of five millimetres and containing thirty milligrams of the chemical mixture, the estimated energy which will be given off from the tube for a discharge of one hour, is 10 amps at between 100 and 110 volts. To enable the tube to give off this discharge, it is only necessary to operate the transmitter at the desired frequency for a period of some fifteen to thirty seconds duration.

The current which is given off by the tube during its discharge is in the form of direct current. During the discharge from the tube, harmful radiations are emitted in the form of gamma rays, alpha rays and beta rays and it is therefore necessary to mount the unit within a lead shield to prevent the harmful radiations from affecting personnel and objects in the vicinity of the unit. The alpha and beta rays which are emitted from the cartridge when it is in operation are controlled by the magnet.

When the unit is connected up to some apparatus which is to be powered by it, it is necessary to provide suitable fuses to guard against the cartridge being short-circuited which could cause the cartridge to explode.

The estimated weight of such a unit including the necessary shielding, per kilowatt hour output, is approximately 25% of any known standard type of accumulator which is in use today and it is estimated that the life of the chemical mixture is probably in the region of seventy to eighty years when under constant use.

It will thus be seen that we have provided a novel form of apparatus for producing an electric current, which is considerably lighter than the standard type of accumulator at present known, and which has an infinitely greater life than the standard type of accumulator, and which can be recharged or reactivated as and when desired and from a remote position depending on the power output of the transmitter. Such form of battery has many applications.

NO-LOAD GENERATOR

Electrical power is frequently generated by spinning the shaft of a generator which has some arrangement of coils and magnets contained within it. The problem is that when current is drawn from the take-off coils of a typical generator, it becomes much more difficult to spin the generator shaft. The cunning design shown in this patent overcomes this problem with a simple design in which the effort required to turn the shaft is not altered by the current drawn from the generator.

ABSTRACT

A generator of the present invention is formed of ring permanent magnet trains 2 and 2' attached and fixed on to two orbits 1 and 1' about a rotational axis 3, magnetic induction primary cores 4 and 4' attached and fixed above outer peripheral surfaces of the ring permanent magnet trains 2 and 2' at a predetermined distance from the outer peripheral surfaces, magnetic induction secondary cores 5 and 5' attached and fixed on to the magnetic induction primary cores 4 and 4' and each having two coupling holes 6 and 6' formed therein, tertiary cores 8 and 8' inserted for coupling respectively into two coupling holes 6 and 6' of each of the associated magnetic induction secondary cores 5 and 5' opposite to each other, and responsive coils 7 and 7'. The ring permanent magnetic trains 2 and 2' are formed of 8 sets of magnets with alternating N and S poles, and magnets associated with each other in the axial direction have opposite polarities respectively and form a pair.

DESCRIPTION**TECHNICAL FIELD**

The present invention relates to generators, and particularly to a load-free generator which can maximise the generator efficiency by erasing or eliminating the secondary repulsive load exerted on the rotor during electric power generation.

BACKGROUND ART

The generator is a machine which converts mechanical energy obtained from sources of various types of energy such as physical, chemical or nuclear power energy, for example, into electric energy. Generators based on linear motion have recently been developed while most generators are structured as rotational type generators. Generation of electromotive force by electromagnetic induction is a common principle to generators regardless of their size or whether the generator is AC or DC generator.

The generator requires a strong magnet such as permanent magnet and electromagnet for generating magnetic field as well as a conductor for generating the electromotive force, and the generator is structured to enable one of them to rotate relative to the other. Depending on which of the magnet and the conductor rotates, generators can be classified into rotating-field type generators in which the magnetic field rotates and rotating-armature type generators in which the conductor rotates.

Although the permanent magnet can be used for generating the magnetic field, the electromagnet is generally employed which is formed of a magnetic field coil wound around a core to allow direct current to flow through them. Even if a strong magnet is used to enhance the rotational speed, usually the electromotive force produced from one conductor is not so great. Thus, in a generally employed system, a large number of conductors are provided in the generator and the electromotive forces generated from respective conductors are serially added up so as to achieve a high electric power.

As discussed above, a usual generator produces electricity by mechanically rotating a magnet (or permanent magnet) or a conductor (electromagnet, electrically responsive coil and the like) while reverse current generated at this time by magnetic induction (electromagnetic induction) and flowing through the coil causes magnetic force which pulls the rotor so that the rotor itself is subjected to unnecessary load which reaches at least twice the electric power production.

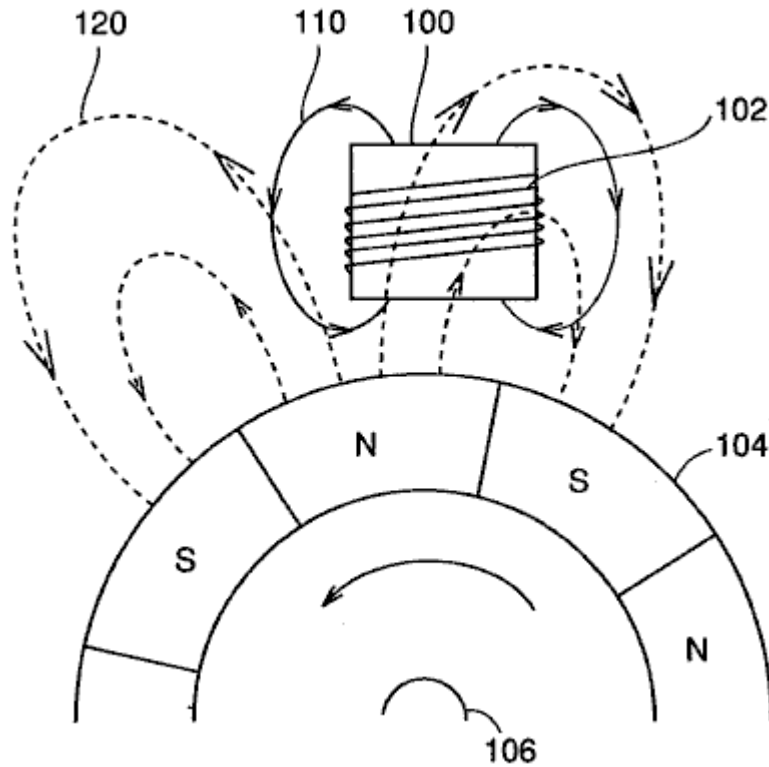

Fig.6 illustrates that the load as discussed above is exerted on a rotor in a rotating-field type generator mentioned above.

Referring to **Fig.6**, a permanent magnet train **104** is arranged about an axis of rotation **106** such that N poles and S poles are alternately located on the outer peripheral surface of the train. At a certain distance outward from the outer periphery of permanent magnet train **104**, a magnetic induction core **100** is arranged and a coil **102** is wound around magnetic induction core **100**.

As permanent magnet train **104** rotates, the magnetic field produced in the coil by permanent magnet train **104** changes to cause induced current to flow through coil **102**. This induced current allows coil **102** to generate a magnetic field **110** which causes a repulsive force exerted on permanent magnet train **104** in the direction which interferes the rotation of the magnet train.

For example, in the example shown in **Fig.6**, the S pole of magnetic field **110** faces permanent magnet train **104**. The S pole of permanent magnet train **104** approaches coil **102** because of rotation of permanent magnet train **104**, resulting in the repulsive force as described above.

If reverse current flows in a responsive coil of an armature wound around a magnetic induction core of a generator so that the resulting load hinders the rotor from rotating, reverse magnetic field of the armature responsive coil becomes stronger in proportion to the electricity output and accordingly a load corresponding to at least twice the instantaneous consumption could occur.

If electric power of 100W is used, for example, reverse magnetic field of at least 200W is generated so that an enormous amount of load affects the rotor to interfere the rotation of the rotor.

All of the conventional generators are subjected to not only a mechanical primary load, i.e. the load when the electric power is not consumed but a secondary load due to reverse current which is proportional to electric power consumption and consequently subjected to a load of at least twice the instantaneous consumption.

Such an amount of the load is a main factor of reduction of the electric power production efficiency, and solution of the problem above has been needed.

DISCLOSURE OF THE INVENTION

One object of the present invention is to provide a generator capable of generating electric power with high efficiency by cancelling out the secondary load except the mechanical load of the generator, i.e. cancelling out the load which is generated due to reverse current of a responsive coil of an armature wound around a magnetic induction core, so as to entirely prevent the secondary load from being exerted.

In short, the present invention is applied to a load-free generator including a rotational axis, a first ring magnet train, a second ring magnet train, a first plurality of first magnetic induction primary cores, a first plurality of second magnetic induction primary cores, a first responsive coil, and a second responsive coil.

The first ring magnet train has N poles and S poles successively arranged on an outer periphery of a first rotational orbit about the rotational axis. The second ring magnet train has magnets successively arranged on an outer periphery of a second rotational orbit about the rotational axis at a predetermined distance from the first rotational orbit such that the polarities of the magnets on the second rotational orbit are opposite to the polarities at opposite locations on the first rotational orbit respectively. The first plurality of first magnetic induction primary cores are fixed along a first peripheral surface of the first ring magnet train at a predetermined distance from the first peripheral surface. The first plurality of second magnetic induction primary cores are fixed along a second peripheral surface of the second ring magnet train at a predetermined distance from the second peripheral surface. A first plurality of first coupling magnetic induction cores and a first plurality of second coupling magnetic induction cores are provided in pairs to form a closed magnetic circuit between the first and second magnetic induction primary cores opposite to each other in the direction of the rotational axis. The first responsive coil is wound around the first coupling magnetic induction core. The second responsive coil is wound around the second coupling magnetic induction core, the direction of winding of the second responsive coil being reversed relative to the first responsive coil.

Preferably, in the load-free generator of the invention, the first ring magnet train includes a permanent magnet train arranged along the outer periphery of the first rotational orbit, and the second ring magnet train includes a permanent magnet train arranged along the outer periphery of the second rotational orbit.

Still preferably, the load-free generator of the present invention further includes a first plurality of first magnetic induction secondary cores provided on respective outer peripheries of the first magnetic induction primary cores and each having first and second coupling holes, and a first plurality of second magnetic induction secondary cores provided on respective outer peripheries of the second magnetic induction primary cores and each having third and fourth coupling holes. The first coupling magnetic induction cores are inserted into the first and third coupling holes to couple the first and second magnetic induction secondary cores, and the second coupling magnetic induction cores are inserted into the second and fourth coupling holes to couple the first and second magnetic induction secondary cores.

Alternatively, the load-free generator of the present invention preferably has a first plurality of first responsive coils arranged in the rotational direction about the rotational axis that are connected zigzag to each other and a first plurality of second responsive coils arranged in the rotational direction about the rotational axis that are connected zigzag to each other.

Alternatively, in the load-free generator of the present invention, preferably the first plurality is equal to 8, and the 8 first responsive coils arranged in the rotational direction about the rotational axis are connected zigzag to each other, and the 8 second responsive coils arranged in the rotational direction about the rotational axis are connected zigzag to each other.

Accordingly, a main advantage of the present invention is that two responsive coils wound respectively in opposite directions around a paired iron cores are connected to cancel reverse magnetic forces generated by reverse currents (induced currents) flowing through the two responsive coils, so that the secondary load which interferes the rotation of the rotor is totally prevented and thus a load-free generator can be provided which is subjected to just a load which is equal to or less than mechanical load when electric power production is not done, i.e. the rotational load even when the generator is operated to the maximum.

Another advantage of the present invention is that the reverse magnetic force, as found in the conventional generators, due to reverse current occurring when the rotor rotates is not generated, and accordingly load of energy except the primary gravity of the rotor and dynamic energy of the rotor is eliminated to increase the amount of electricity output relative to the conventional electric power generation system and thus enhance the electric power production and economic efficiency.

BRIEF DESCRIPTION OF THE DRAWINGS

Fig.1 is a cross sectional view of a rotating-field type generator according to an embodiment of the present invention illustrating an arrangement a permanent magnet, magnetic induction cores and coils.

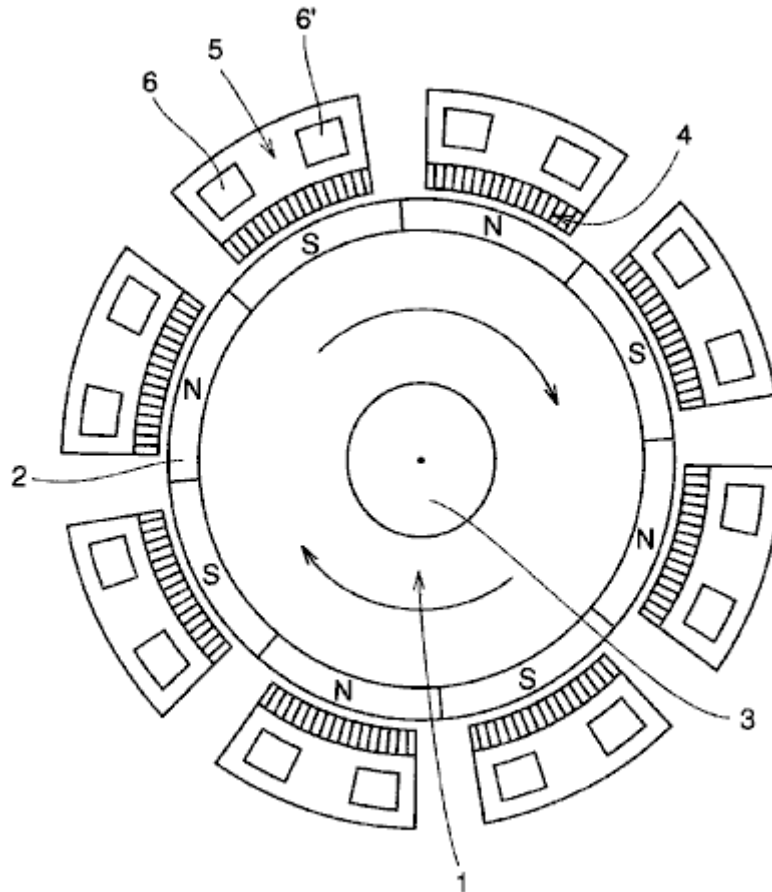

FIG. 1

Fig.2 is a partial schematic view illustrating a magnetic array of the permanent magnet rotor and an arrangement of one of magnetically responsive coils placed around that rotor in an embodiment of the present invention.

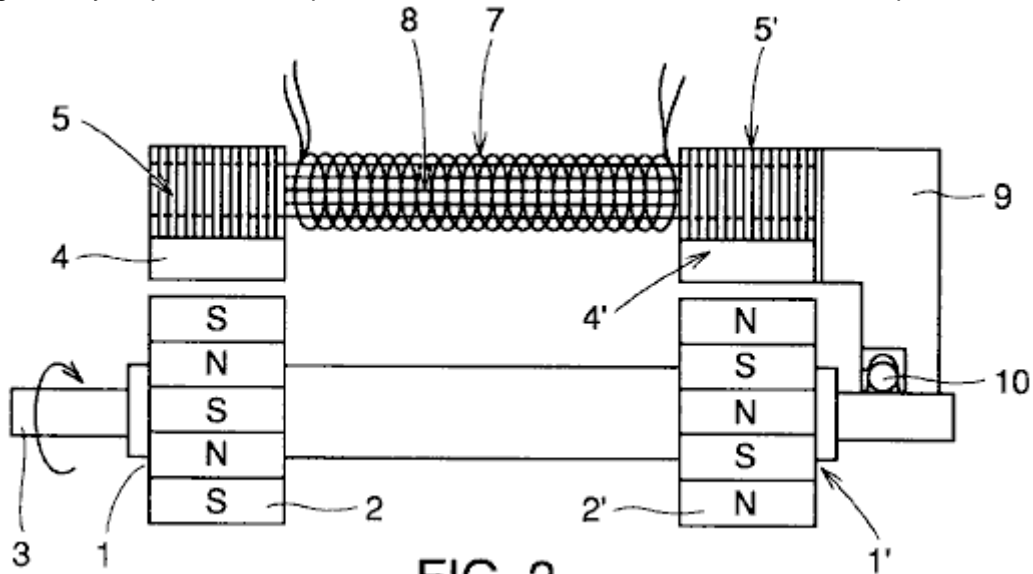

FIG. 2

Fig.3 illustrates a structure of the magnetically responsive coils and cores in the embodiment of the present invention.

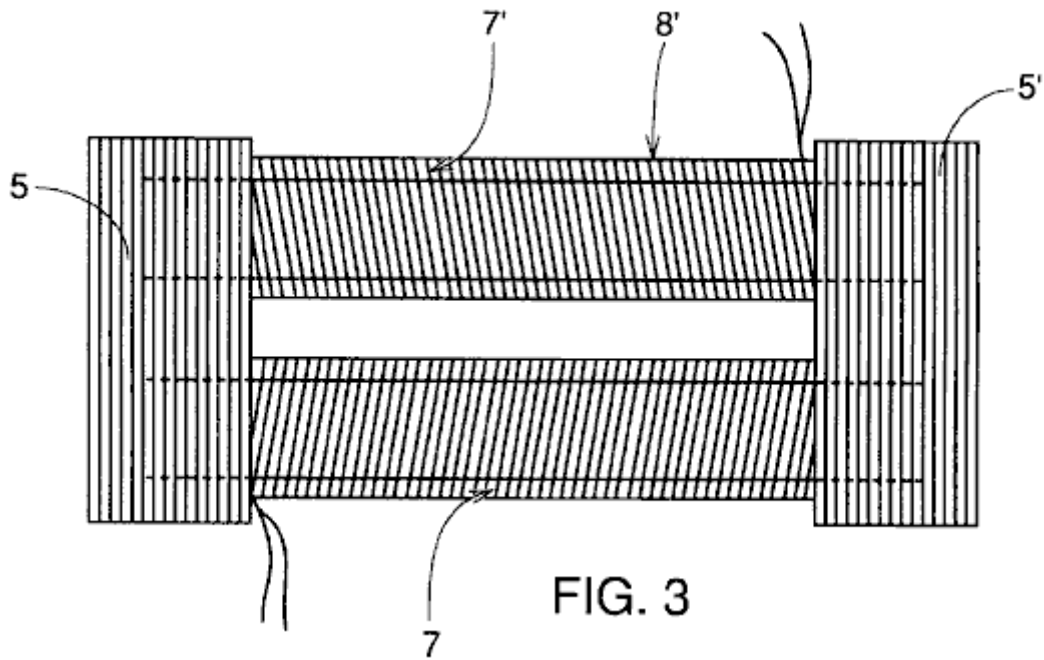

Fig.4 is an enlarged plan view of magnetically sensitive cores and coil portions of the load-free generator of the present invention illustrating magnetic flow therethrough.

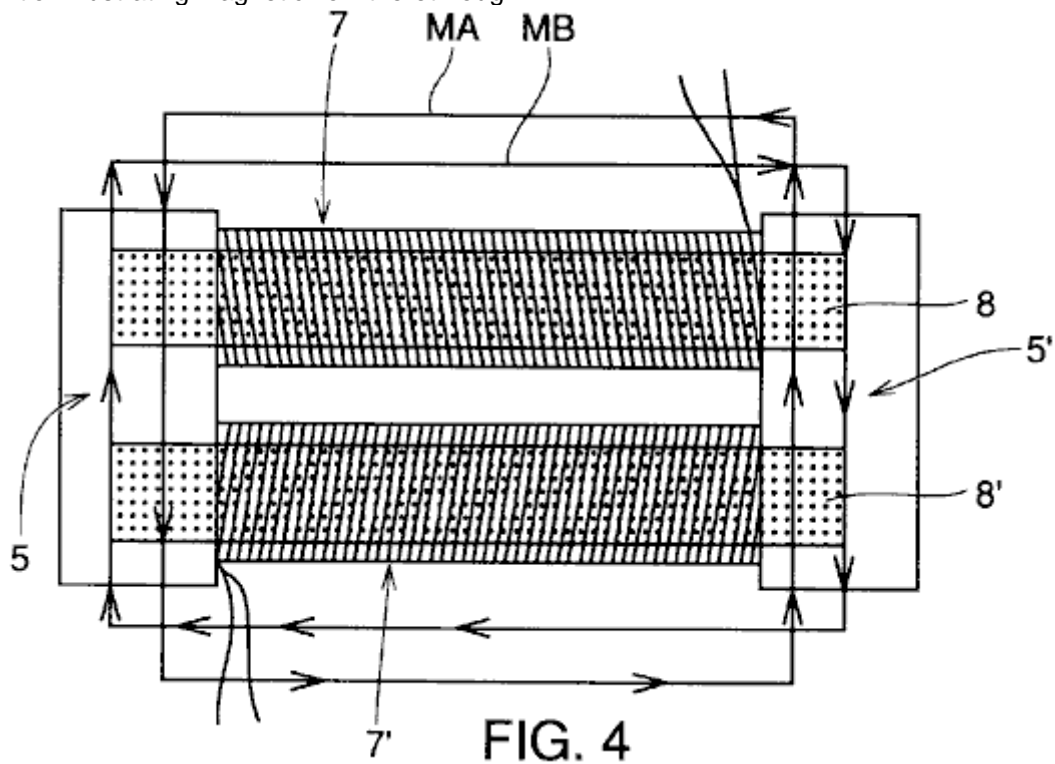

Fig.5 is an exploded view about a central axis showing the interconnection of magnetic field coils which are respectively wound around tertiary cores surrounding the permanent magnet rotor in FIG. 1 according to the present invention.

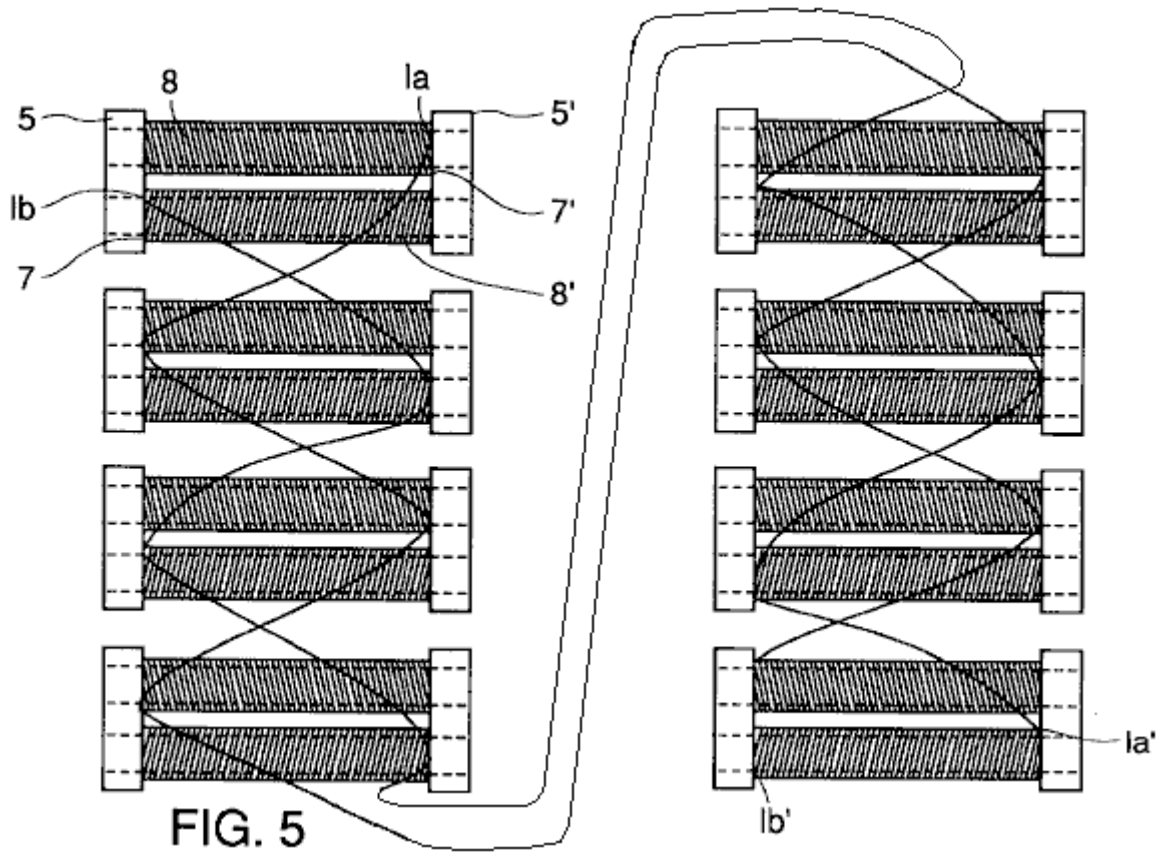
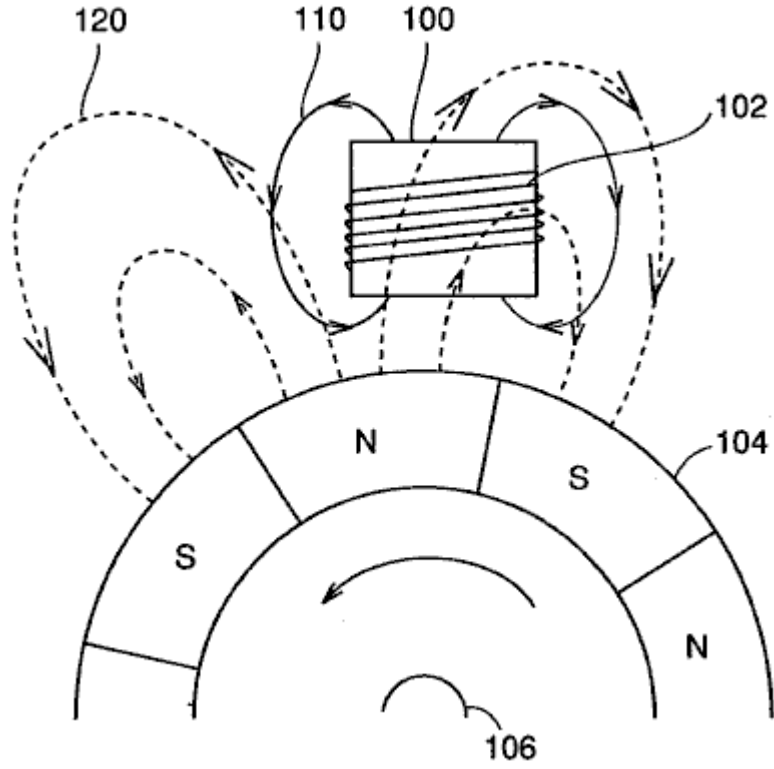

Fig.6 illustrates generation of the secondary load in a conventional generator.



BEST MODES FOR CARRYING OUT THE INVENTION

The structure and operation of a load-free generator according to the present invention are now described in conjunction with the drawings.

Fig.1 illustrates a cross sectional structure of the load-free generator of the invention perpendicular to a rotational axis **3**.

Fig.2 partially illustrates a cross sectional structure of the load-free generator of the invention in parallel to rotational axis **3**. Specifically, in **Fig.2**, only one of eight sets of magnetic induction primary cores **4** and **4'** arranged around rotational axis **3** as described below is representatively shown.

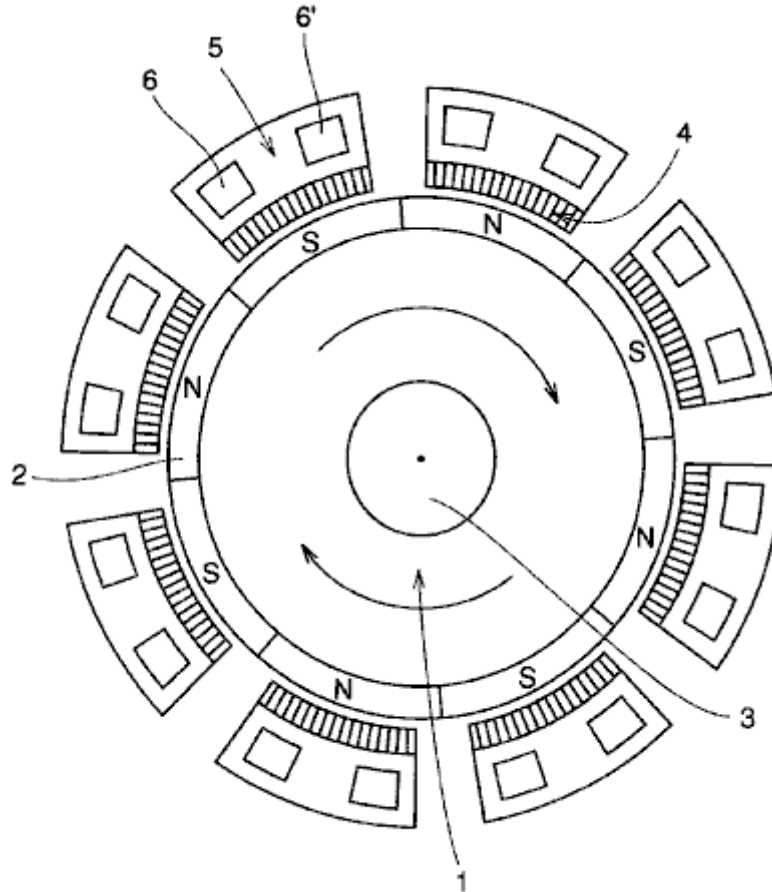
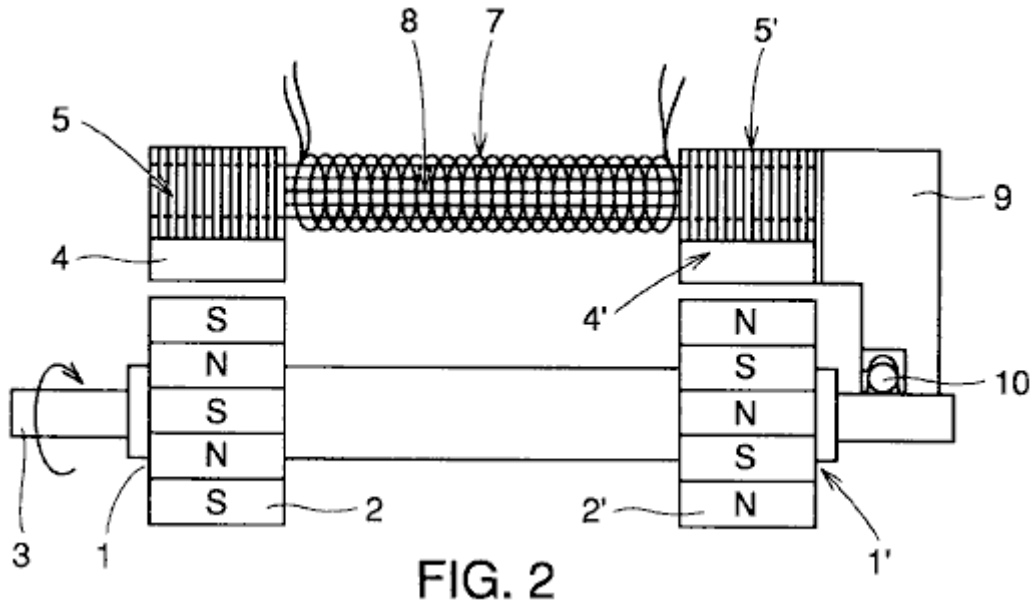

FIG. 1

Referring to **Fig.1** and **Fig.2**, the structure of the load-free generator of the invention is now described. Permanent magnet trains **2** and **2'** in ring forms are attached and fixed to respective left and right orbits **1** and **1'** provided relative to rotational axis **3** with a certain interval between them. Permanent magnet trains **2** and **2'** are fixed onto left and right orbits **1** and **1'** respectively such that the polarities on the outer peripheral surface of each magnet train relative to the rotational axis are alternately N poles and S poles. The permanent magnet trains are rotatable about the axis. Further, the facing polarities of respective permanent magnet train **2** and permanent magnet train **2'** relative to the direction of rotational axis **3** are arranged to be opposite.



As shown in **Fig.2**, rotational axis **3** and a case **9** are joined by a bearing **10** at a certain distance from the permanent magnet trains **2** and **2'**.

At a predetermined distance from permanent magnet trains **2** and **2'**, magnetic induction primary cores **4** and **4'** with respective coils wound around them are fixed to case **9**.

In addition, magnetic induction secondary cores **5** and **5'** each having two coupling holes **6** and **6'** formed therein are structured by stacking and coupling a plurality of thin cores attached and fixed to magnetic induction primary cores **4** and **4'** respectively and the secondary cores are attached and fixed to case **9**.

Magnetic induction tertiary cores **8** and **8'** are inserted respectively into coupling holes **6** and **6'** of magnetic induction secondary cores **5** and **5'** so as to couple magnetic induction secondary cores **5** and **5'** of each other.

Responsive coils **7** and **7'** are wound in opposite directions to each other around respective magnetic induction cores **8** and **8'**.

Fig.3 illustrates a structure formed of magnetic induction secondary cores **5** and **5'**, magnetic induction cores **8** and **8'** and responsive coils **7** and **7'** viewed in the direction perpendicular to rotational axis **3**.

As explained above, the directions of windings of responsive coils **7** and **7'** are respectively opposite to each other around magnetic induction cores **8** and **8'** which couple magnetic induction secondary cores **5** and **5'**.

In the structure described in conjunction with **Fig.1**, **Fig.2** and **Fig.3**, when rotational axis **3** of the generator rotates, permanent magnetic trains **2** and **2'** accordingly rotate to generate magnetically sensitive currents (electromagnetically induced current) in responsive coils **7** and **7'** and the current thus produced can be drawn out for use.

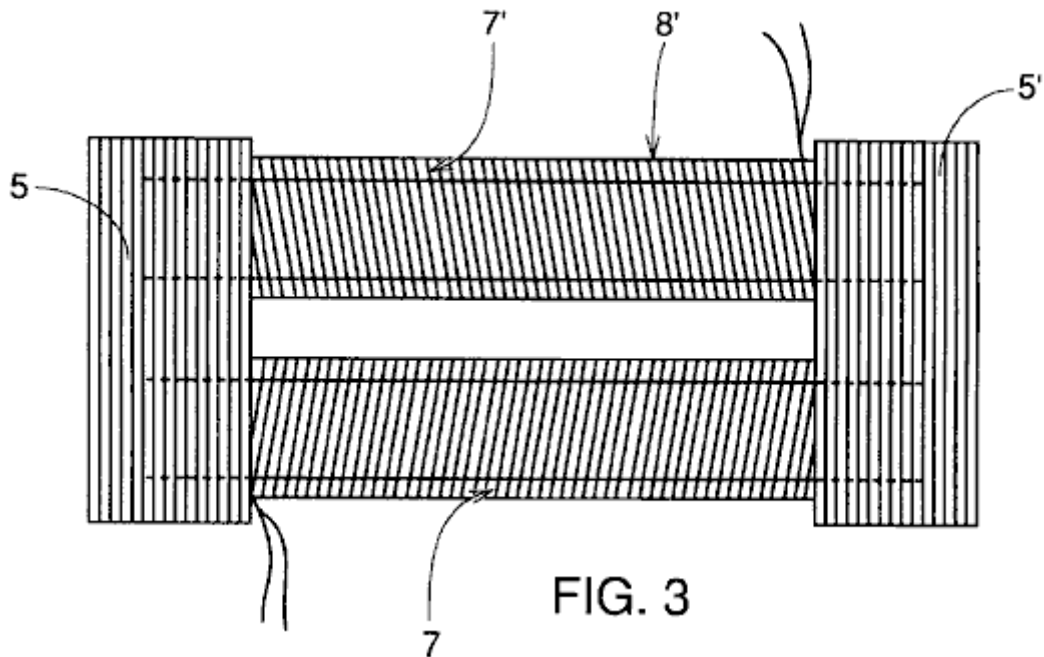

FIG. 3

As shown in **Fig.3**, the coils are wound about magnetic induction cores **8** and **8'** respectively in the opposite directions in the generator of the present invention, and the directions of the magnetic fields generated by the flow of the induced currents are arranged such that the N pole and S pole alternately occurs around rotational axis **3**.

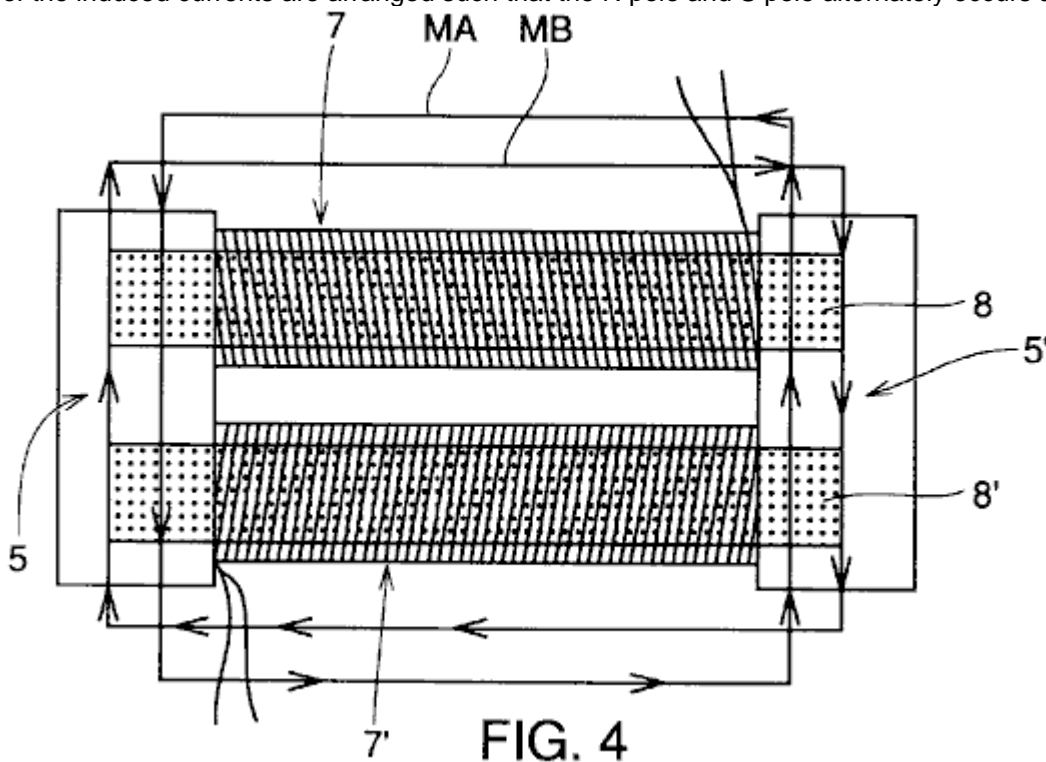

FIG. 4

Fig.4 illustrates magnetic fields induced in a set of magnetic induction secondary cores **5** and **5'**, magnetic induction cores **8** and **8'** and responsive coils **7** and **7'**.

At iron strips on both ends of respective magnetic induction secondary cores **5** and **5'**, a reverse current magnetic field is generated by responsive coil **7** upon the rotation of N and S poles of permanent magnet trains **2** and **2'** is in the direction of **MA** shown in **Fig.4**, for example, while a reverse current magnetic field generated by responsive coil **7** is in the direction of **MB** in **Fig.4**. Consequently, the reverse magnetic fields generated by the flow of currents cancel each other. The cores are formed of a plurality of iron strips in order to eliminate heat generated by eddy currents.

The magnetic field of the rotor thus has no dependence on the flow of currents, the load caused by the induced magnetisation phenomenon disappears, and energy of movement necessary for rotation against the mechanical primary load of the rotor itself is applied to the rotor.

At this time, a magnetic circuit including magnetic induction secondary cores **5** and **5'** and magnetic induction tertiary cores **8** and **8'** should be shaped into ".quadrature." form. If the circuit does not structured as ".quadrature." form, a part of the reverse magnetic field functions as electrical force which hinders the rotational force of the rotor.

Further, permanent magnet trains **2** and **2'** of the rotor are arranged to have opposite poles to each other on the left and right sides as shown in **Fig.2** so as to constitute the flow of magnetic flux. Each rotor has alternately arranged magnets, for example, eight poles are provided to enhance the generator efficiency.

More detailed description of the operational principle is given now. When the rotor in **Fig.1** rotates once, S and N poles of permanent magnets **2** and **2'** attached to the periphery of the rotor successively supply magnetic fields to induction primary cores **4** above, and magnetic field is accordingly generated in a path from one orbit of the rotor along induction primary core **4**, induction secondary core **5**, induction tertiary core **8**, induction secondary core **5'**, induction primary core **4'** to the other orbit of the rotor as shown in **Fig.2**.

Accordingly, current flows in the coils affected by this electric field to generate electric power. For example, if the generated power is used as generated output for switching on an electric light or for using it as motive energy, the current flowing through the coils generates the reverse magnetic fields. However, this reverse magnetic fields do not influence permanent magnets **2** and **2'** attached to the rotor in **Fig.2** since the reverse magnetic fields of the same magnitude respectively of S and N or N and S on both ends of magnetic induction secondary cores **5** and **5'** cancel out each other as shown in **Fig.4**. Because of this, the rotor is in a no-load state in which any resistance except the weight of the rotor itself and dynamic resistance is not exerted on the rotor.

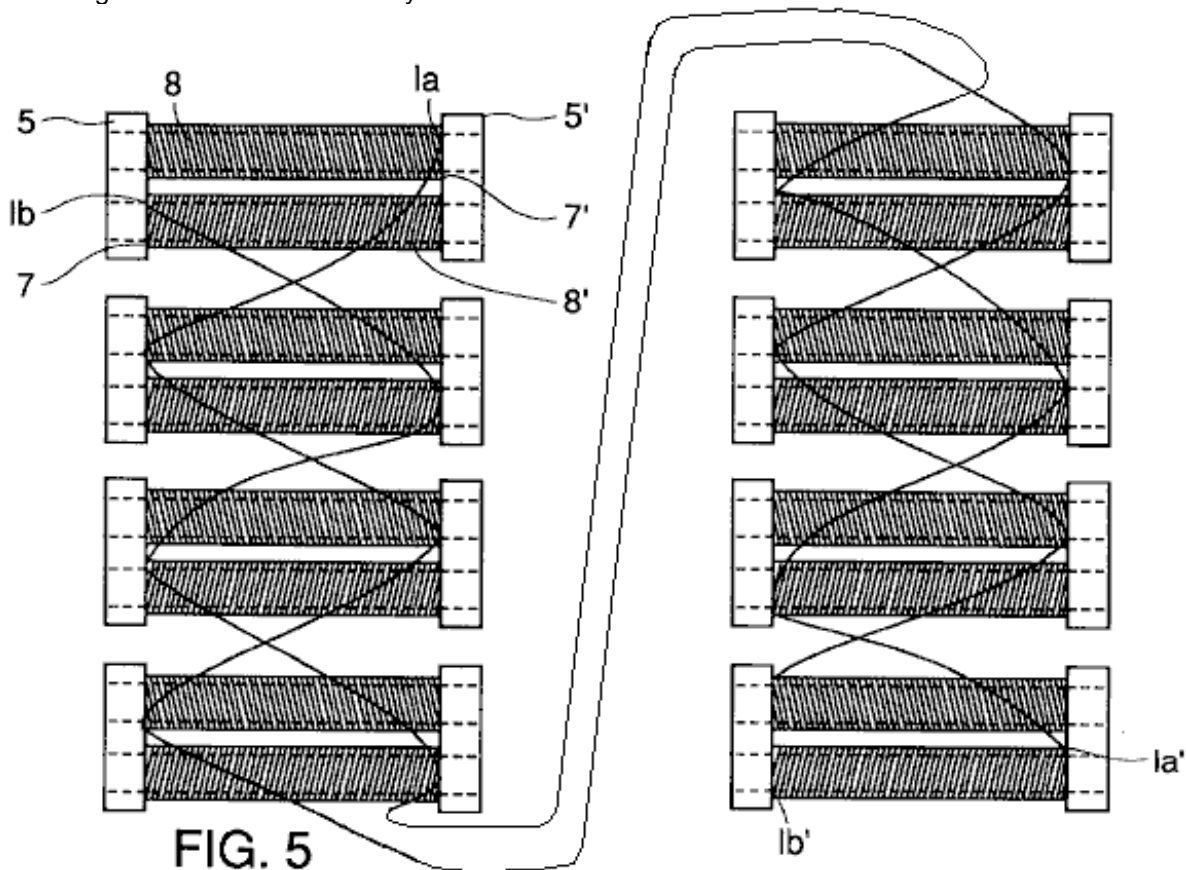

Fig.5 illustrates a manner of connecting magnetically responsive coils **7** and **7'** wound around magnetic induction tertiary cores **8** and **8'** with eight poles.

Referring to **Fig.5**, according to a method of connecting magnetically responsive coils **7** and **7'**, line **1a1** of responsive coil **7'** (one drawn-out line of the wire coiled around a first magnetic induction core **8**) is connected to line **1a2'** (one drawn-out line of the wire coiled around a second magnetic induction core **8**), and then line **1a2** (the other drawn-out line of the wire coiled around a second magnetic induction core **8**) is connected to line **1a3'**, and subsequently lines **1a** and **1a'** are connected successively in zigzag manner to allow current to flow. Further, responsive coil **7** is arranged to connect lines represented by **1b1** in zigzag manner such that lines **1b** and **1b'** are successively connected. In this way, lines **1b**, **1b'** and lines **1a** and **1a'** of respective magnetically responsive coils **7** and **7'** are connected. As a whole, total four electric wires are drawn out for use.

When electric power is to be generated according to the present invention as described above, specifically, a closed circuit is formed by responsive coils **7** and **7'**, electric currents are induced in responsive coils **7** and **7'** wound around the magnetic induction cores of the generator, and the induced magnetic fields produced respectively by responsive coils **7** and **7'** could cause a great load which interferes the rotational force of the rotor. However, as shown in **Fig.4**, the direction of convolution of one coil **7** is opposite to that of the other coil **7'** so that the magnetic force generated by the reverse currents (induced currents) in responsive coils **7** and **7'** wound around magnetic induction core **4** is not transmitted to magnetic induction cores **8** and **8** accordingly no reverse magnetic force is transmitted to permanent magnets **2** and **2'**.

Therefore, each time the N poles and S poles alternate with each other because of the alternation of permanent magnets **2** and **2'** shown in **Fig.2**, the reverse magnetic forces in the right and left direction opposite to the direction of arrows denoted by **MA** and **MB** completely disappear as shown in **Fig.4**. Consequently, the reverse magnetic forces caused by the reverse currents are not influenced by permanent magnets **2** and **2'** and accordingly no load except the mechanical primary load is exerted on the generator of the invention.

As discussed above, the load-free generator of the present invention, secondary load except mechanical load of the generator, i.e. the load caused by the reverse currents flowing through the responsive coils can be nulled. With regard to this load-free generator, even if 100% of the current generated by magnetic induction (electromagnetic induction) is used, the magnetic secondary load due to the reverse currents except the mechanical primary load does not serve as load.

Although the number of poles of the rotor is described as **8** in the above description, the present invention is not limited to such a structure, and the invention can exhibit its effect when the smaller or greater number of poles is applied.

Further, although the magnet of the rotor is described as the permanent magnet in the above structure, the invention is not limited to such a case and the magnet of the rotor may be an electromagnet, for example.

In addition, although the description above is applied to the structure of the rotating-field type generator, the generator may be of the rotating-armature type.

EXPERIMENTAL EXAMPLE

More detailed description of the generator of the present invention is hereinafter given based on specific experimental examples of the invention.

The generator of the present invention and a conventional generator were used to measure the electric power production efficiency and the amount of load and compare the resultant measurements.

EXPERIMENTAL EXAMPLE 1

A 12-pole alternating current (AC) generator for battery charging was used, and the electricity output and the load when 50% of the electricity output was used as well as those when 100% of the electricity output was used were measured. The generator above is a single-phase AC motor and the employed power source was 220V, with 1750 rpm and the efficiency of 60%. The result of measurement using power of a motor of 0.5HP and ampere .times.volt gauge is shown in **Table 1**.

EXPERIMENTAL EXAMPLE 2

Measurement was done under the same conditions as those of experimental example 1 and a generator used was the one which was made according to the present invention to have the same conditions as those of the product of the existing model above. The result of measurement using ampere x volt gauge is shown in **Table 1**.

Table 1

Type of Generator	50% Electricity Used		100% Electricity Used	
	Electricity Output (Watts)	Amount of Load (Watts)	Electricity Output (Watts)	Amount of Load (Watts)
Conventional:	100	221	14	347
This invention:	100	220	183	200

(electricity output and load amount of the alternating current generators when 50% and 100% of the electricity were used)

From the result of Experimental Example 1 above, the reason for the remarkable reduction of the electricity output when the electricity consumption was 100% relative to the electricity consumption of 50% in the conventional generator is considered to be the significant increase of the repulsive load exerted on the generator when 100% of the electricity is used.

On the other hand, in the generator of the present invention, there was no appreciable difference in the amount of load between those cases in which 50% of the electricity was used and 100% thereof was used respectively. Rather, the amount of load slightly decreased (approximately 20W) when 100% of the electricity was used. In view of this, it can be understood that the amount of generated electric power of the generator of the present invention is approximately doubled as the electricity consumption increases, which is different from the conventional generator producing electric power which sharply decreases when the electricity consumption increases.

In conclusion, the amount of load above is supposed to be numerical value relative to the mechanical load of the generator as described above. Any secondary load except this, i.e. load due to the reverse currents generated in the armature responsive coils can be confirmed as zero.

EXPERIMENTAL EXAMPLE 3

12V direct current (DC) generators having similar conditions to those in experimental example 1 were used to make measurement under the same conditions (efficiency 80%). The result of the measurement is presented below.

Table 2

Type of Generator	50% Electricity Used		100% Electricity Used	
	Electricity Output (Watts)	Amount of Load (Watts)	Electricity Output (Watts)	Amount of Load (Watts)
Conventional:	103	290	21	298
This invention:	107	282	236	272

(electricity output and load amount of the alternating current generators when 50% and 100% of the electricity were used)

The DC generator has higher efficiency (80%) than that of the AC generator, while use of the brush increases the cost of the DC generator. When 100% of the electricity was used, the amount of load slightly decreased which was similar to the result shown in Table 1 and the electricity output was approximately at least 2.2 times that when 50% of the electricity was used.

EXPERIMENTAL EXAMPLE 4

A 220V single-phase alternating current (AC) generator (0.5HP) having similar conditions to those in experimental example 1 was used, and the rotation per minute (rpm) was changed to make measurement under the condition of 100% consumption of the generated electricity. The result of measurement is illustrated in the following **Table 3**.

Table 3

1750 rpm		3600 rpm		5100 rpm	
Electricity Output (Watts)	Amount of Load (Watts)	Electricity Output (Watts)	Amount of Load (Watts)	Electricity Output (Watts)	Amount of Load (Watts)
130	160	210	228	307	342

(amounts of generated electric power and load when the rotation per minute of the generator of the present invention was varied)

As shown in **Table 3** above, as the rotation per minute (rpm) increases as from 1750, 3600 to 5100, the amount of electric power increases respectively from 130, 210 to 307W and consequently the difference between the amount of generated electric power and the amount of load decreases to cause relative decrease of the amount of load as the rotation per minute (rpm) increases.

EXPERIMENTAL EXAMPLE 5

Measurement was done by changing the number of N and S poles of the permanent magnets of the invention under the same conditions as those of experimental example 1 and under the condition that 100% of the generated electricity was used.

The result of the measurement is illustrated below.

Table 4

2 poles		4 poles		8 poles	
Electricity Output (Watts)	Amount of Load (Watts)	Electricity Output (Watts)	Amount of Load (Watts)	Electricity Output (Watts)	Amount of Load (Watts)
80	152	130	200	265	296

(amounts of generated electric power and load when the number of poles of the permanent magnets of the generator of the invention was changed)

From **Table 4** above, it can be understood that as the number of poles increases, both of the amounts of generated electric power and load increase. However, the ratio of the amount of generated electric power to the amount of load monotonously increases. In the table above, in terms of the amount of load, only the mechanical primary load is exerted and electrical secondary is not exerted.

The increase of the number of poles causes increase, by the number of increased poles, in the number of lines of magnetic flux which coils traverse, and accordingly the electromotive force increases to increase the amount of generated electric power. On the other hand, the amount of mechanical load has a constant value regardless of the increase of the number of poles, so that the mechanical load amount relatively decreases to reduce the difference between the amount of load and the amount of generated electric power.

Detailed description of the present invention which has been given above is just for the purpose of presenting example and illustration, not for limitation. It will dearly be appreciated that the spirit and scope of the invention will be limited only by the attached scope of claims.

ALBERTO MOLINA-MARTINEZ

Patent Application US 20020125774 6th March 2002 Inventor: Alberto Molina-Martinez

CONTINUOUS ELECTRICAL GENERATOR

This patent application shows the details of a device which it is claimed, can produce sufficient electricity to power both itself and external loads. It also has no moving parts.

ABSTRACT

A stationary cylindrical electromagnetic core, made of one piece thin laminations stacked to desired height, having closed slots radially distributed, where two three-phase winding arrangements are placed together in the same slots, one to the centre, one to the exterior, for the purpose of creating a rotational electromagnetic field by temporarily applying a three-phase current to one of the windings, and by this means, inducing a voltage on the second one, in such a way that the outgoing energy is a lot greater than the input. A return will feedback the system and the temporary source is then disconnected. The generator will run by itself indefinitely, permanently generating a great excess of energy.

BACKGROUND OF THE INVENTION

1. Field of the Invention

The present invention relates generally to electrical power generating systems. More specifically, the present invention relates to self-feeding electrical power generating units.

2. Description of Related Art

Since Nikola Tesla invented and patented his Polyphase System for Generators, Induction Motors and Transformers, no essential improvement has been made in the field. The generators would produce the polyphase voltages and currents by means of mechanical rotational movement in order to force a magnetic field to rotate across the generator's radially spaced windings. The basis of the induction motor system was to create an electro-magnetically rotating field, instead of a mechanically rotated magnetic field, which would induce voltages and currents to generate electromotive forces usable as mechanical energy or power. Finally, the transformers would manipulate the voltages and currents to make them feasible for their use and transmission for long distances.

In all present Electric Generators a small amount of energy, normally less than one percent of the outgoing power in big generators, is used to excite the mechanically rotated electromagnetic poles that will induce voltages and currents in conductors having a relative speed or movement between them and the polar masses.

The rest of the energy used in the process of obtaining electricity, is needed to move the masses and to overcome the losses of the system: mechanical losses; friction losses; brushes losses, windage losses; armature reaction losses; air gap losses; synchronous reactance losses; eddy current losses; hysteresis losses, all of which, in conjunction, are responsible for the excess in power input (mechanical power) required to generate always smaller amounts of electric power.

SUMMARY OF THE INVENTION

The **Continuous Electrical Generator** consists of a stationary cylindrical electromagnetic core made of one piece thin laminations stacked together to form a cylinder, where two three-phase windings arrangements are placed in the same slots not having any physical relative speed or displacement between them. When one of the windings is connected to a temporary three-phase source, an electromagnetic rotating field is created, and the field this way created will cut the stationary coils of the second winding, inducing voltages and currents. In the same way and extent as in common generators, about one percent or less of the outgoing power will be needed to keep the rotational magnetic field excited.

In the **Continuous Electrical Generator** there are no mechanical losses; friction losses; brush losses; windage losses; armature reaction losses; or air gap losses, because there is not any movement of any kind. There are: synchronous reactance losses, eddy current losses and hysteresis losses, which are inherent to the design, construction and the materials of the generator, but in the same extent as in common generators.

One percent or less of the total energy produced by present electric generators goes to create their own magnetic field; a mechanical energy that exceeds the total output of present generators is used to make them rotate in the process of extracting electrical currents from them. In the **Continuous Electrical Generator** there is no need for movement since the field is in fact already rotating electro-magnetically, so all that mechanical energy will not be needed. Under similar conditions of exciting currents, core mass and windings design, the **Continuous Electrical Generator** is significantly more efficient than present generators, which also means that it can produce significantly more than the energy it needs to operate. The **Continuous Electrical Generator** can feedback the system, the temporary source may be disconnected and the Generator will run indefinitely.

As with any other generator, the **Continuous Electrical Generator** may excite its own electromagnetic field with a minimum part of the electrical energy produced. The **Continuous Electrical Generator** only needs to be started up by connecting its inducting three-phase windings to a three-phase external source for an instant, and then to be disconnected, to start the system as described herein. Then, disconnected, it will run indefinitely generating a great excess of electric power to the extent of its design.

The **Continuous Electrical Generator** can be designed and calculated with all mathematical formulas in use today to design and calculate electrical generators and motors. It complies with all of the laws and parameters used to calculate electrical induction and generation of electricity today.

Except for the Law of Conservation of Energy, which, by itself, is not a mathematical equation but a theoretical concept and by the same reason does not have any role in the mathematical calculation of an electrical generator of any type, the **Continuous Electrical Generator** complies with all the Laws of Physics and Electrical Engineering. The **Continuous Electrical Generator** obligates us to review the Law of Conservation of Energy. In my personal belief, the electricity has never come from the mechanical energy that we put into a machine to move the masses against all oppositions. The mechanical system is actually providing the path for the condensation of electricity. The **Continuous Electrical Generator** provides a more efficient path for the electricity.

DESCRIPTION OF DRAWINGS

Fig.1 shows one embodiment of the present invention.

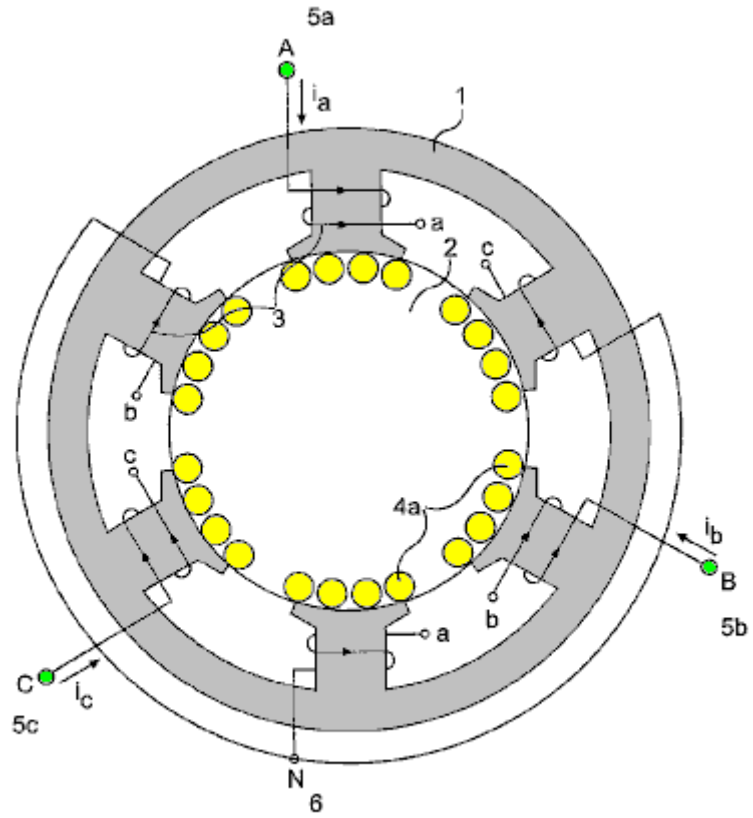

FIG. 1

Fig.2 shows an internal wiring diagram for the embodiment of the present invention shown in Fig.1.

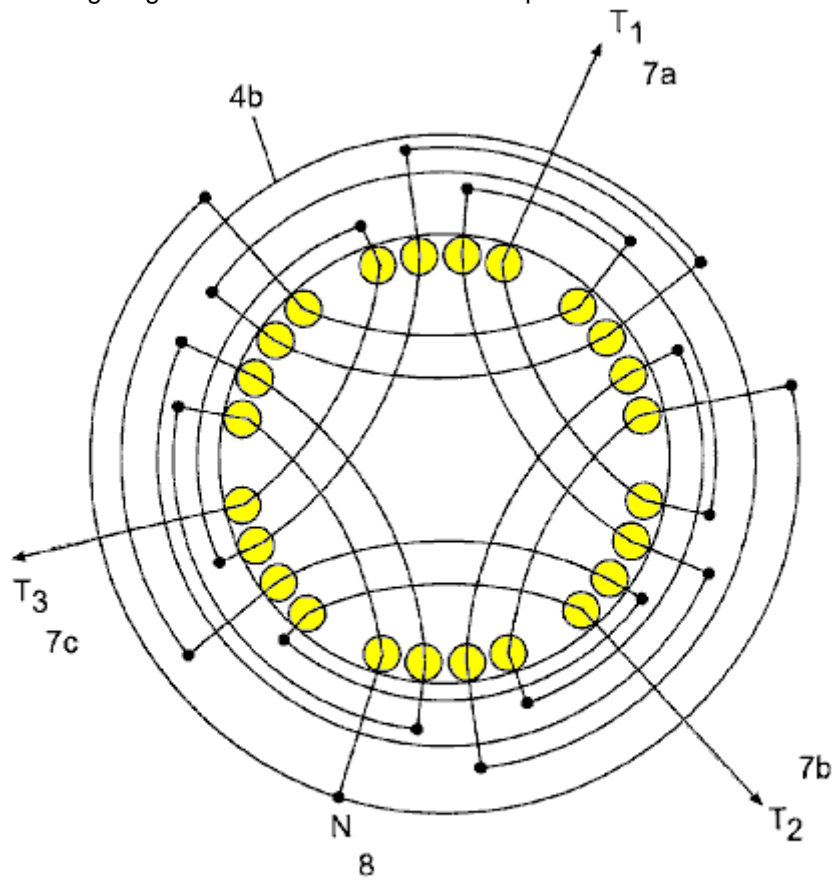

FIG. 2

Fig.3 shows a single laminate for an alternate embodiment of the present invention.

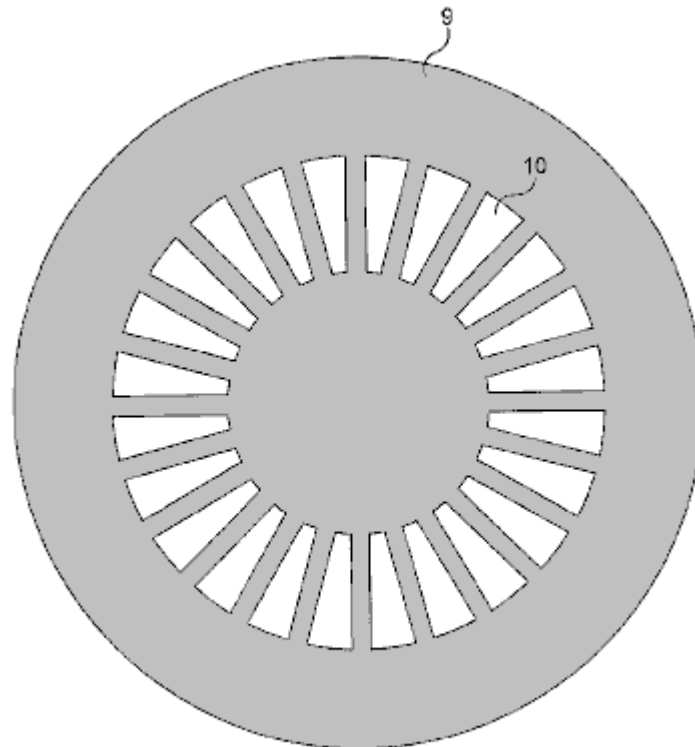

FIG. 3

Fig.4 shows a two-piece single laminate for another alternate embodiment of the present invention.

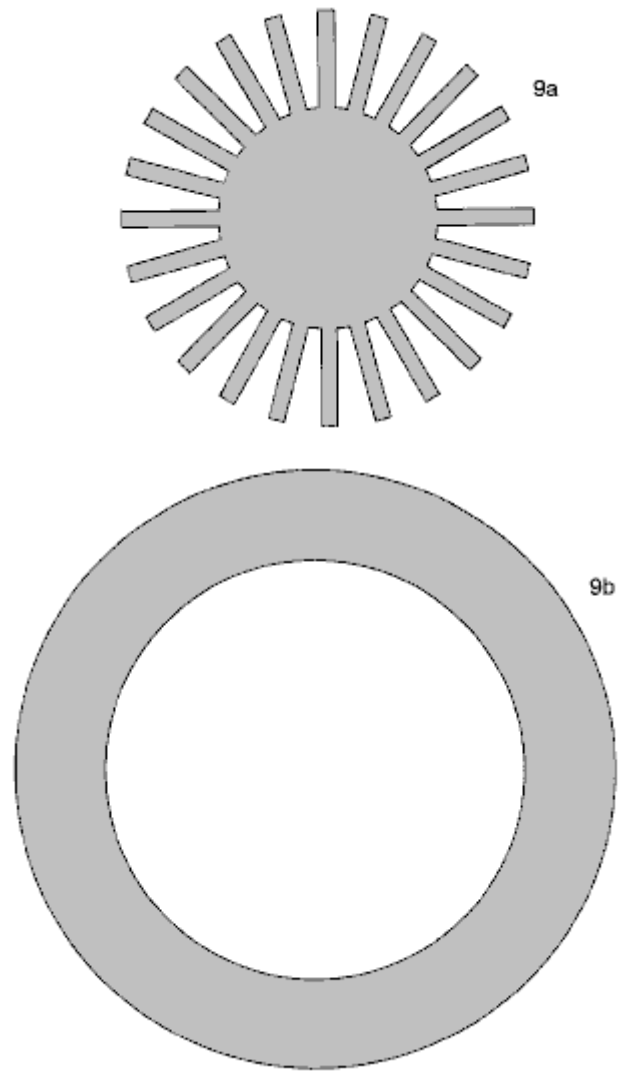

FIG. 4

Fig.5 shows a wiring diagram for an embodiment of the present invention constructed from the laminate shown in **Fig.3** or **Fig.4**.

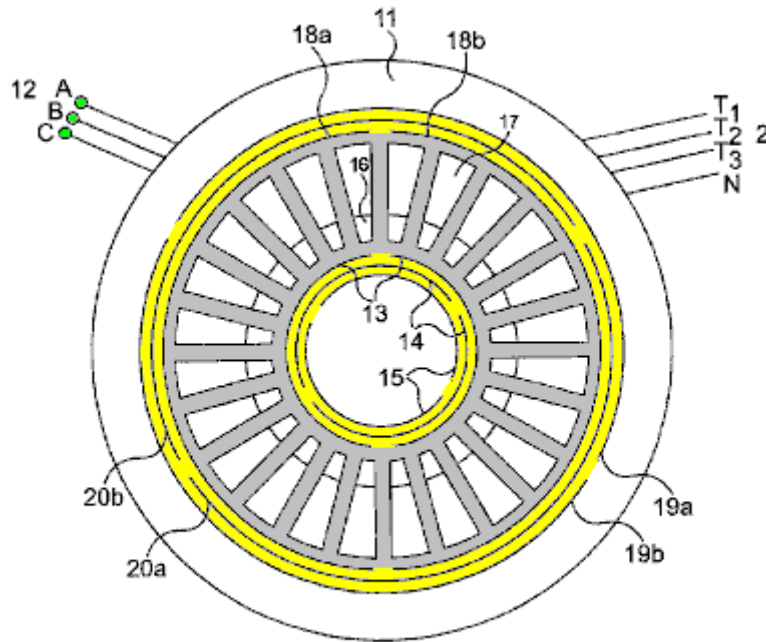

FIG. 5

Fig.6 shows the magnetic flux pattern produced by the present invention.

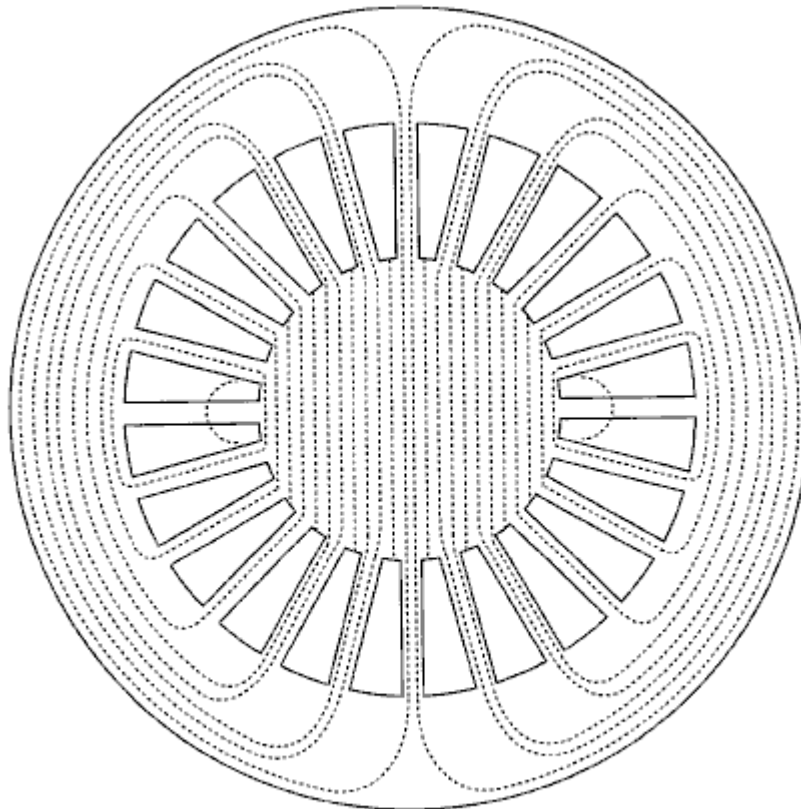

FIG. 6

Fig.7 shows the rotational magnetic field patterns produced by the present invention.

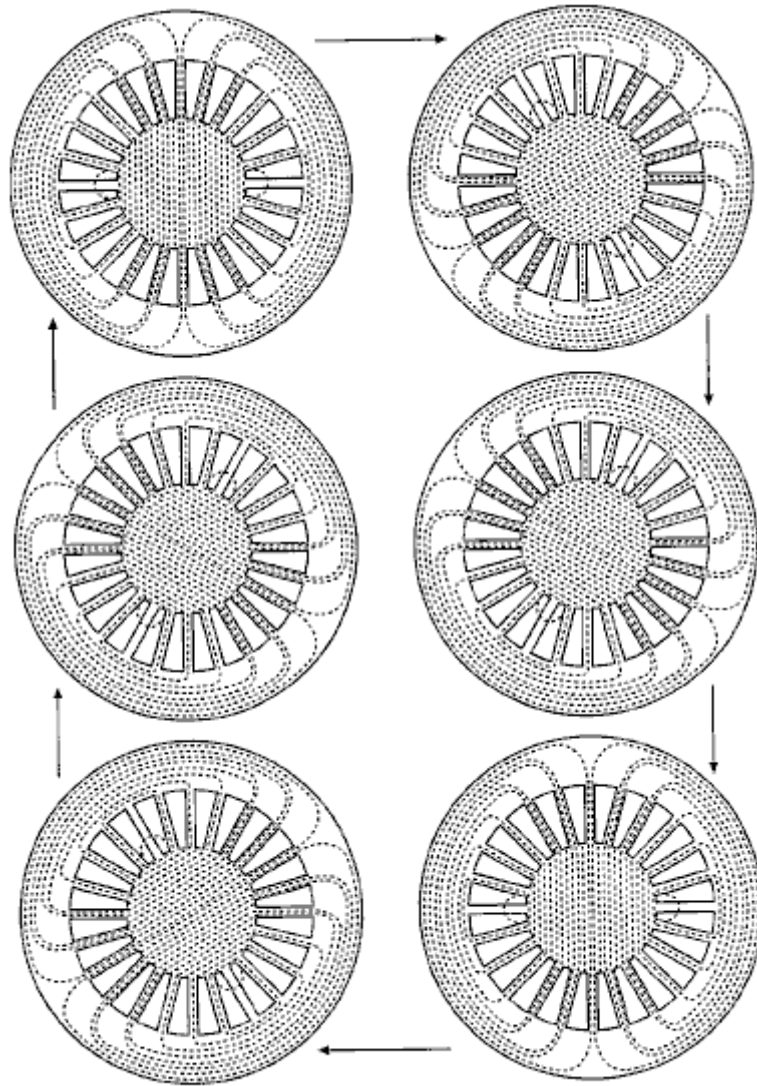

FIG. 7

Fig.8 shows the complete system of the present invention.

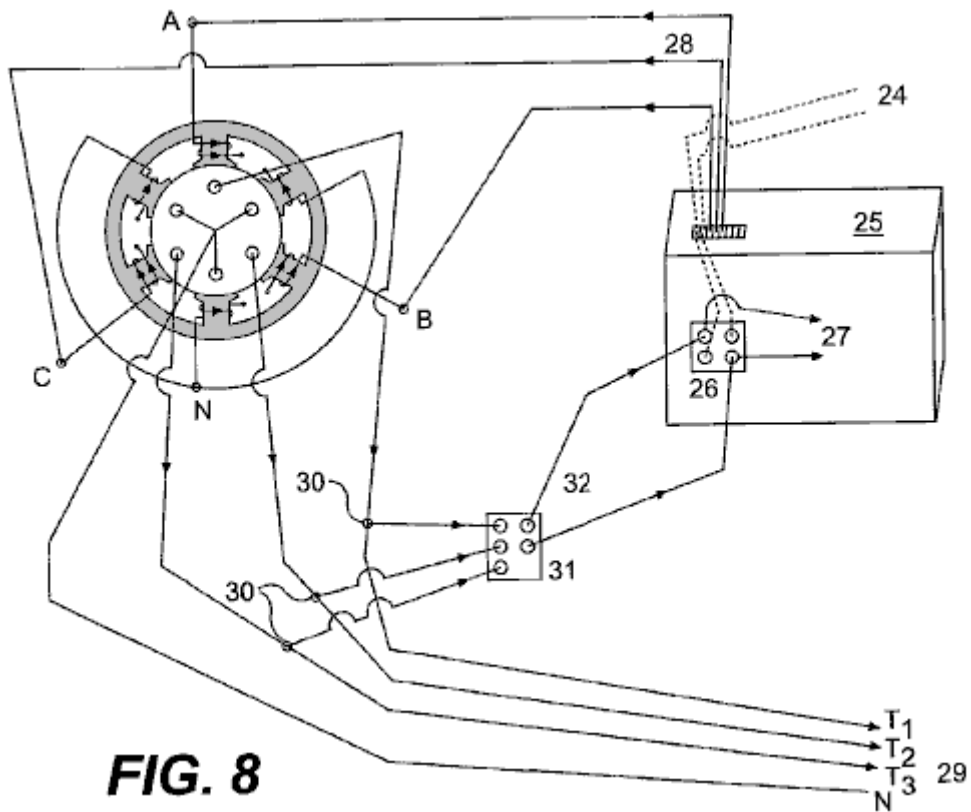

FIG. 8

Fig.9 is an expanded view of the alternate embodiment of the present invention shown in Fig.3 or Fig.4.

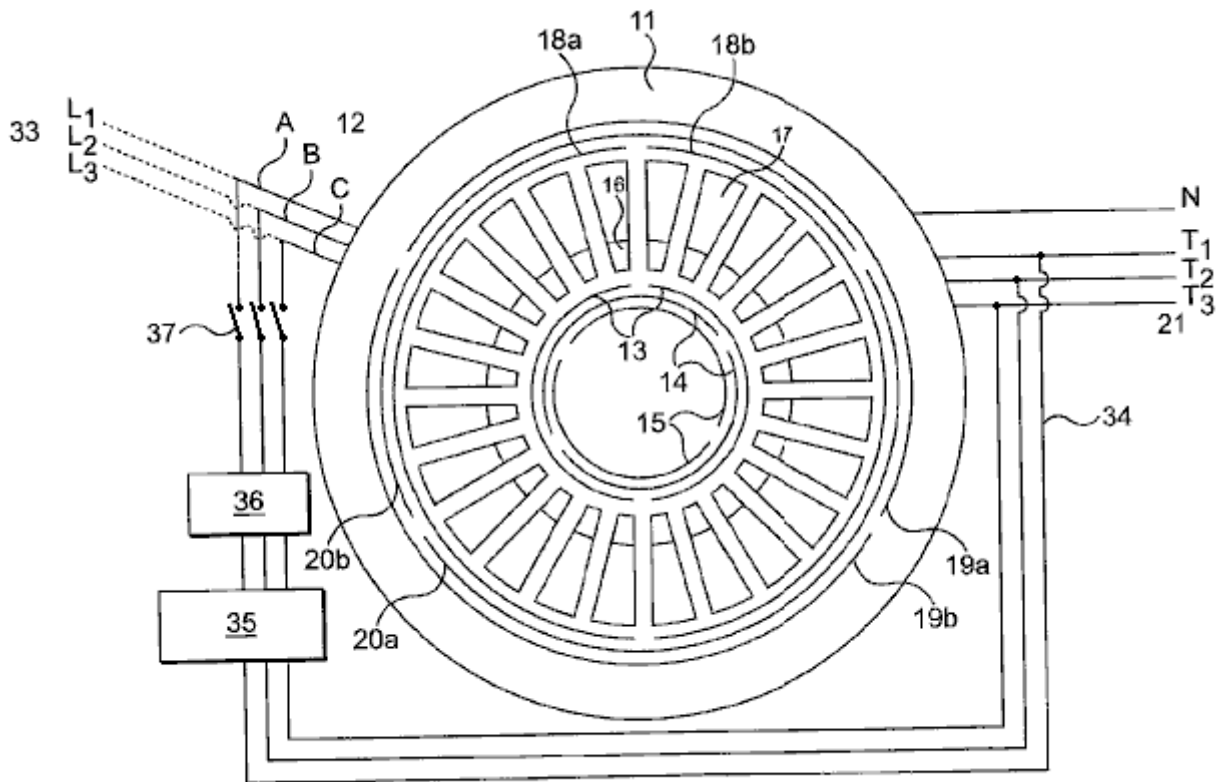

FIG. 9

DETAILED DESCRIPTION OF THE INVENTION

The present invention is a Continuous and Autonomous Electrical Generator, capable of producing more energy than it needs to operate, and which provides itself the energy needed to operate. The basic idea consists in the induction of electric voltages and currents without any physical movement by the use of a rotational magnetic field created by a three-phase stator connected temporarily to a three-phase source, and placing stationary conductors on the path of said rotational magnetic field, eliminating the need of mechanical forces.

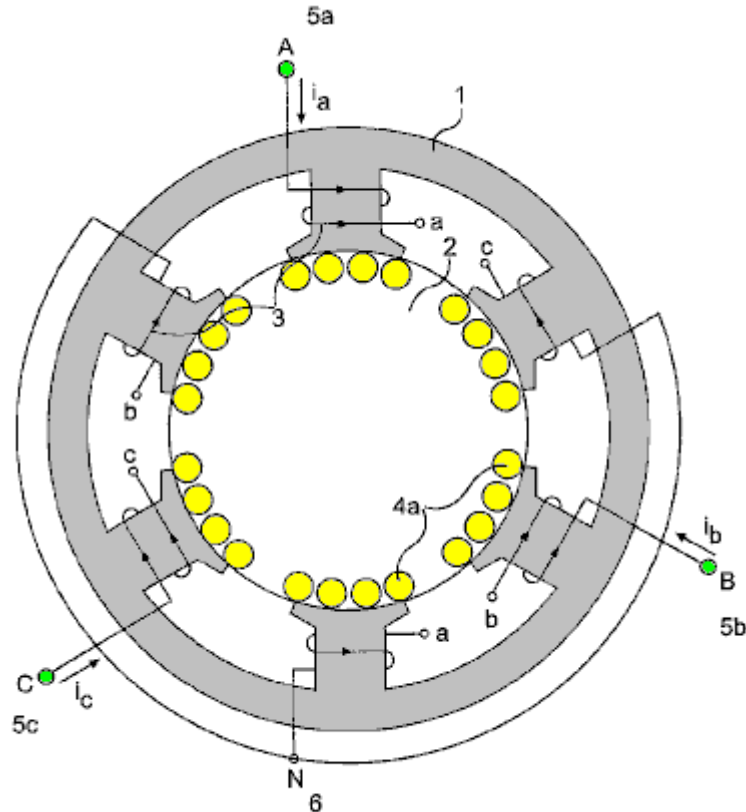

FIG. 1

The basic system can be observed in **Fig.1**, which shows one embodiment of the present invention. There is a stationary ferromagnetic core **1** with a three-phase inducing windings **3**, spaced 120 degrees and connected in Y **6** in order to provide a rotating electromagnetic field, when a three-phase voltage is applied; for the case, a two-pole arrangement. Inside this core **1** there is a second stationary ferromagnetic core **2**, with no space between them, this is, with no air-gap. This second core **2** has also a three-phase stationary winding arrangement (**4a** in **Fig.4b** and **4b** in **Fig.2**), aligned as shown in **Fig.1** and **Fig.2** with the external core inducing windings **3**. There is not any movement between the two cores, since there is no air-gap between them.

There is no shaft on either core since these are not rotating cores. The two cores can be made of stacked insulated laminations or of insulated compressed and bonded ferromagnetic powder. The system works either way, inducing three-phase voltages and currents on the stationary conductors **4a** of the internal windings **4b**, applying three-phase currents to terminals **A 5a**, **B 5b** and **C 5c** of the external windings **3**; or inducing three-phase voltages and currents on the external windings **3**, by applying three-phase currents to the terminals **T1 7a**, **T2 7b** and **T3 7c**, of the internal windings **4b**. When a three-phase voltage is applied to terminals **A 5a**, **B 5b** and **C 5c**, the currents will have the same magnitude, but will be displaced in time by an angle of 120 degrees. These currents produce magneto motive-forces, which, in turn, create a rotational magnetic flux. The arrangements may vary widely as they occur with present alternators and three-phase motors, but the basics remain the same, a stationary but electro-magnetically rotating magnetic field, inducing voltages and currents on the stationary conductors placed on the path of said rotating magnetic field. The diagram is showing a two-pole arrangement for both windings, but many other arrangements may be used, as in common generators and motors.

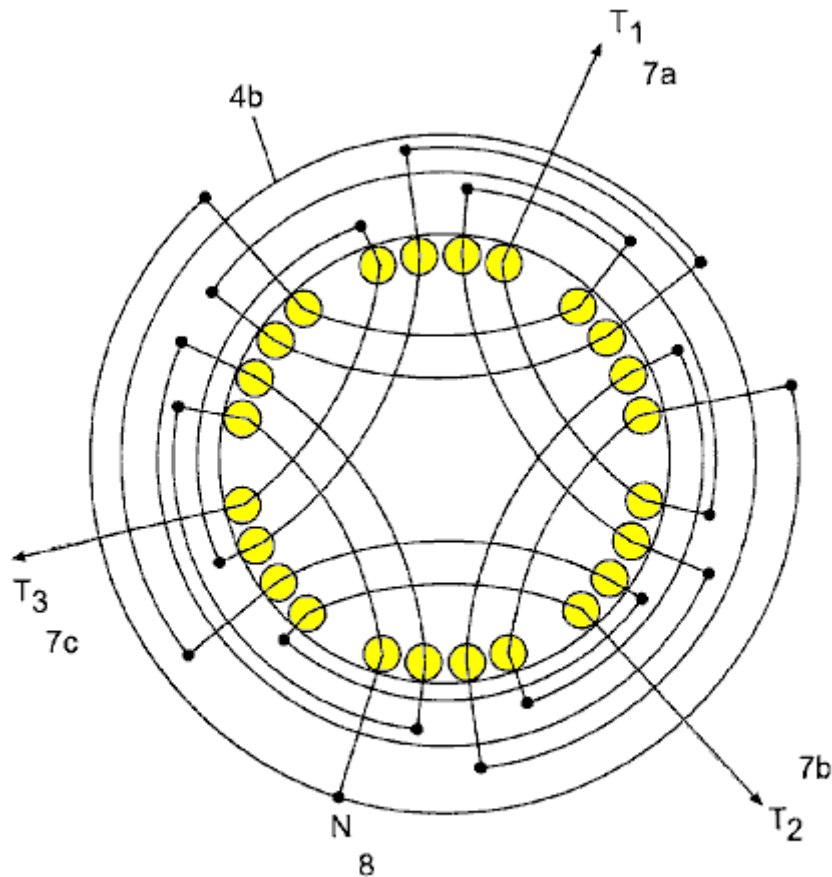

FIG. 2

Fig.2 shows the three-phase arrangement of the internal winding **4b** which has provided, in practice, symmetrical voltages and currents, due to a space angle of 120 degrees. It is similar to a two-pole arrangement. Many other three-phase or poly-phase arrangements may be used. Wherever a conductor is crossed by a rotational magnetic field, a voltage will be induced across its terminals. The interconnections depend on the use that we will give to the system. In this case, we will have a three-phase voltage in terminals **T1 7a**, **T2 7b** and **T3 7c** and a neutral **8**. The outgoing voltage depends on the density of the rotational magnetic flux, the number of turns of the conductor, the frequency (instead of the speed) and the length of the conductor crossed by the field, as in any other generator.

Fig.3 shows an alternate embodiment of the present invention in which the generator is made from multiple one-piece laminations **9**, stacked as a cylinder to the desired height. This embodiment can also be made of a one-piece block of compressed and bonded insulated ferromagnetic powder. The same slot **10** will accommodate the internal **4a/4b** and the external windings **3**, that is, the inducing and the induced windings (see **Fig.5**). In this case, a 24-slot laminate is shown, but the number of slots may vary widely according to the design and needs.

Fig.4 shows a two-piece single laminate for another alternate embodiment of the present invention. For practical effects the lamination can be divided into two pieces **9a**, **9b**, as shown, to facilitate the insertion of the coils. Then, they are solidly assembled without separation between them, as if they were only one piece.

The laminates described above may be constructed with thin (0.15 mm thick or less) insulated laminations **9** or **9a** and **9b** of a high magnetic permeability material and low hysteresis losses such as Hiperco 50A, or similar, to reduce losses or with compressed electrically isolated ferromagnetic powder, which has lower eddy current losses and also may have low hysteresis losses, which can make the generator highly efficient.

OPERATING THE GENERATOR

The **C**ontinuous **E**lectrical **G**enerator as described and shown in the following drawings is designed and calculated to produce a strong rotating electromagnetic field with low exciting currents. By using a laminated material, such as the said Hiperco 50A, we can achieve rotating magnetic fields above two Teslas, since there are no air gap losses, mechanical losses, windage losses, armature reaction losses, etc. as said before. This may be obtained by applying a temporary three-phase current to the terminals **A**, **B** and **C** 12 of the inducing coils 13, 14 and 15 (5a, 5b and 5c in Fig.1), spaced 120 degrees from each other (see Fig.5).

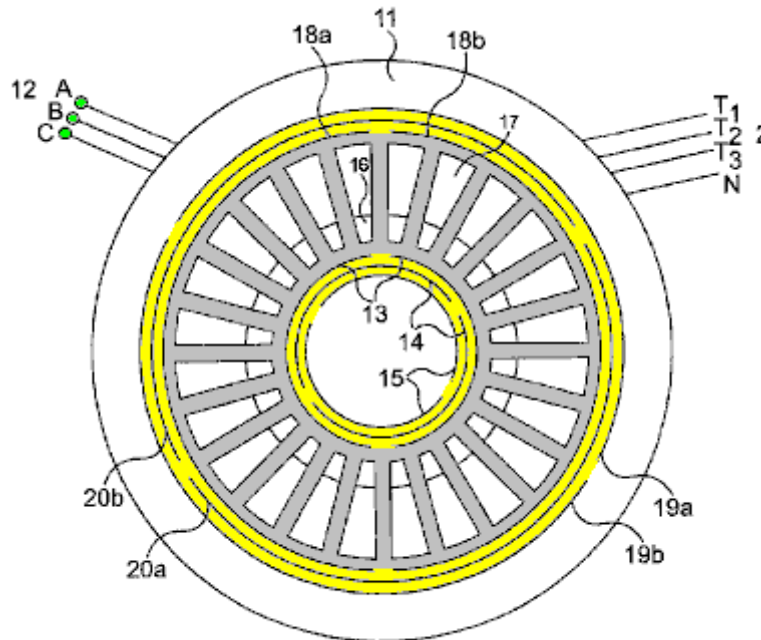

FIG. 5

Fig.5 shows the spatial distribution of the inducing windings 13, 14 and 15, as well as the induced windings 18a, 18b, 19a, 19b, 20a and 20b. Both, the inducing and the induced windings are placed in the same slots 10 or 16 and 17, with similar arrangements. Even though the system works in both directions, the better configuration seems to be to place the inducing windings 13, 14 and 15, to the centre and the induced windings 18a, 18b, 19a, 19b, 20a and 20b, to the exterior, since small windings will be needed to induce a very strong rotational magnetic field, due to the small losses involved in the process, and in exchange, bigger and powerful windings will be needed to extract all the energy that the system will provide. Both windings are connected in Y (not shown), but they can be connected in different ways, as any other generator. These arrangements are equivalent to the arrangements shown for the embodiment in **Fig.1** and **Fig.2**.

The inducing coils 13, 14 and 15 are designed and calculated so that the generator may be started with common three-phase lines voltages (230 Volts 60 Hz per phase, for example). If the local lines voltages are not appropriate, we can control the voltage to the designed level by means of a three-phase variable transformer, an electronic variator or inverter etc. Once we have such strong magnetic field rotating and crossing the stationary induced coils 18a, 18b, 19a, 19b, 20a and 20b, a three-phase voltage will be induced across terminals T1, T2, T3 and N 21 in proportion to the magnetic flux density, the number of turns in the coils, the frequency used (instead of the speed), the length of the conductors cut by the rotating field, as in any other alternator. We can connect, as we desire in Y or delta, etc., as in any other alternator or generator. The outgoing currents will be three-phase currents (or poly-phase currents depending on the arrangement) and we can have a neutral 21 if we are using a Y connection, as in any other alternator.

The outgoing alternate voltages and currents are perfect sinusoidal waves, perfectly spaced in time, and totally symmetrical. The voltages and currents obtained by this method are usable in any conventional manner. Any voltage can be produced, depending on the design.

Fig.6 shows the magnetic flux pattern produced by the three-phase inducing windings 13, 14 and 15. This pattern is similar to the pattern of an induction motor's stators. Since there is no air gap; the whole path for the magnetic flux is homogeneous with no change in materials. The core is made of thin insulated laminations of a high magnetic permeability and low hysteresis loss material; eddy current losses are minimal due to the thin lamination. There are no counter fluxes or armature reactions thus the magnetic flux may be near to saturation with a small exciting current or input energy. Due to the time differential between the three phases and the spatial distribution of the inducing windings, a rotational magnetic field will be created in the core, as shown in **Fig.7**.

Once the generator is started, a small part of the energy obtained is sent back (**Fig.8** and **Fig.9**) to feed the inducting coils **3** (in **Fig.1**) or **13, 14** and **15** (in **Fig.5**), as in any other auto-excited alternator or generator. Of course voltages and phases should be perfectly identical and aligned, and if necessary the feedback voltages should be controlled and handled by means of variable transformers, electronic variators, phase shifters (to align phases) or other type of voltage or phase controllers.

One possible method consists of the use of an electronic converter or variator **25** which initially converts two or three lines of alternating current **24** to direct current by an electronic rectifier **26** and then, electronically, converts the direct current **27** to three-phase current **28** to supply three-phase currents spaced in time 120 degrees for the electromagnetic fields **A, B** and **C 3**. Some variators or converters can accept two lines of voltage, while others will accept only a three-phase line voltage. This embodiment uses a variator of 3 kVA that accepts two 220-volt lines.

The rotational magnetic field created by the currents going through the inducting three-phase windings **13, 14** and **15**, will induce a voltage across the terminals **T1, T2, T3, N, 29 (7a, 7b, 7c, 8** in **Fig.2**). Then, from the outgoing current lines **29**, a derivation is made **30** to feed back the system, converting the feed back alternate currents, by means of electronic diode rectifiers **31**, to direct current **32** and then feed back the electronic converter or variator **25** to the DC terminals of the electronic rectifier **26** (See **Fig.8**). Once the feedback is connected, the **Continuous Electrical Generator** may be disconnected from the temporary source **24**, and will continue generating electric energy indefinitely.

In **Fig.9**, an alternate embodiment of the **Continuous Electrical Generator** can be observed. The basic principles remain the same as for the embodiment described above and shown in **Fig.1** and **Fig.2**. The basic differences are in the shape of the laminations and the physical distribution of the windings, as discussed and shown previously. A variation of the feedback, using a variable and shifting transformers is also shown.

The ferromagnetic core **11** is made of one-piece laminates **9** as shown in **Fig.3** (or two for convenience **9a, 9b** as shown in **Fig.4**) stacked to the desired height. The slots **10**, as indicated before, will accommodate both the inducting **13, 14** and **15** and the induced **18a-b, 19a-b** and **20a-b** windings in the same slot **10** or **16** and **17**. The incoming three phase lines **12** feed the inducting three-phase windings **13, 14** and **15**. They are fed, initially by the temporary source **33** in the first instance, and by the three-phase return **34** once the generator is running by itself.

The inducting windings **13, 14** and **15** have a two-pole arrangement, but many other three-phase or poly-phase arrangements can be made to obtain an electromagnetic rotating field. These windings are connected in Y (not shown) in the same way shown for the embodiment shown in **Fig.1, Fig.2** and **Fig.8**, but may be connected in many different ways. The inducting windings **13, 14** and **15** are located in the internal portion **16** of the slot **10** (**Fig.5**).

The induced windings **18a-b, 19a-b** and **20a-b** have a two-pole arrangement, exactly equal to the arrangement for the inducting windings **13, 14** and **15**, but many other arrangements can be made depending on the design and the needs. The induced windings must be calculated in a way that the generator will have the lowest possible synchronous reactance and resistance. In this way, most of the outgoing power will go to the charge instead of staying to overcome the internal impedance. These windings are connected in Y to generate a neutral **21**, in the same way shown in the embodiment of the present invention shown in **Fig.2**, but may be connected in different ways according to the needs. The induced windings **18a-b, 19a-b** and **20a-b** are located in the external portion **17** of the slot **10**.

The outgoing three-phase and neutral lines **21** come from the induced windings **18a-b, 19a-b** and **20a-b**. The rotational magnetic field created in the core (see **Fig.6 & Fig.7**) by the inducting windings **13, 14** and **15**, induces a voltage across the terminals **T1, T2** and **T3**, plus a neutral, **29**. From each of the three-phase outgoing lines **21**, a return derivation **34** is made to feedback the system.

The temporary three-phase source **33** is temporarily connected to terminals **A, B** and **C 12**. The **Continuous Electrical Generator** must be started with an external three-phase source for an instant, and then disconnected.

Even though the return lines voltage can be calculated and obtained precisely by tabbing the induced windings at the voltage required by the inducting windings (according to the design), it may be convenient to place a three-phase variable transformer or other type of voltage controller **35** in the middle for more precise adjustment of the return voltage.

Placed after the variable transformer **35**, the three-phase shifting transformer **36** will correct and align any phase shift in the voltage and currents angles, before the return is connected. This system functions similarly to the system shown in **Fig.8** which uses a variator or a converter **25**.

Once the voltage and phases are aligned with the temporary source **33**, the return lines **34** are connected to the incoming lines **A, B** and **C 12** at feedback connection **37** and the temporary source **33** is then disconnected. The **Continuous Electrical Generator** will remain working indefinitely without any external source of energy, providing a great excess of energy permanently.

The outgoing electric energy provided by this system has been used to produce light and heat, run poly-phase motors, generate usable mono-phase and poly-phase voltages and currents, transform voltages and currents by means of transformers, convert the alternate outgoing poly-phase currents to direct current, as well as for other uses. The electricity obtained by the means described is as versatile and perfect as the electricity obtained today with common electric generators. But the **Continuous Electrical Generator** is autonomous and does not depend on any other source of energy but itself once it is running; may be carried anywhere with no limitations; it can be constructed in any size and provides any amount of electricity indefinitely, according to the design.

The **Continuous Electrical Generator** is and will be a very simple machine. The keystones of the systems reside in the ultra-low losses of a non-movement generation system, and in a very low synchronous reactance design.

The induced windings must be calculated in a way that the generator may have the lowest possible synchronous reactance and resistance. In this way, most of the outgoing power will go to the charge instead of staying to overcome the internal impedance.

SEMICONDUCTOR COMPOSITIONS

This patent application shows the details of a device which it is claimed, can produce electricity via a solid-state oscillator. It should be noted that while construction details are provided which imply that the inventor constructed and tested several of these devices, this is only an application and not a granted patent.

ABSTRACT

A resonance oscillator electric power pack for operating a flash lamp, for example, or other electrically operated device, operates without moving mechanical parts or electrolytic action. The power pack is contained in a cylindrical metal envelope and in a preferred embodiment, is coupled to a relaxation oscillator and an incandescent lamp. Within the envelope, and insulated from it, is a semiconductor tablet having a metal base connected to the external circuit. A metal probe makes contact with a point on the semiconductor tablet and with a cylindrical ferrite rod, axially aligned with the envelope. Wound about the ferrite rod, are concentric helical coils designated as a 'primary' with many turns, and a 'secondary' with fewer turns than the primary.

One end of the primary coil is connected to the probe and the other end is connected to the secondary coil. The leads from the secondary coil are connected to the relaxation oscillator via an adjustable capacitor. Oscillation within the envelope is resonance amplified, and the induced voltage in the secondary coil is rectified for application to the relaxation oscillator and lamp. Selenium and germanium base semiconductor compositions including Te, Nd, Rb and Ga in varying proportions are used for the tablet.

BACKGROUND OF THE INVENTION

This is a continuation-in-part of my co-pending patent application Serial No. 77,452, filed 2nd October 1970, entitled "Electric Power Pack" now abandoned.

In many situations it is desirable to have a source of electric power which is not dependent on wires from a central generating station, and therefore, portable power supplies having no moving parts have been employed. Typically, such portable power packs have been primary or secondary electrolytic cells which generate or store electrical energy for release by chemical action. Such batteries have a limited amount of contained energy and must often be replaced at frequent intervals to maintain equipment in operation.

Thus, as one example, flashing lights are commonly used along highways and other locations to warn of dangerous conditions. These flashing lights in remote locations are typically incandescent or gas-discharge lamps connected to some type of relaxation oscillator powered by a battery. The batteries employed in such blinking lights have a limited lifetime and must be periodically replaced, typically each 250 to 300 hours of operation. This involves a rather large labour cost in replacing the expended batteries with fresh ones and additional cost for primary cells or for recharging secondary cells. It is desirable to provide an electric power pack capable of providing a sufficient quantity of electrical energy over a prolonged period of time so that the requirement for periodic replacement of the electrolytic cells can be avoided. Such a power pack is valuable even if appreciably more expensive than batteries because of the greatly reduced labour costs required for periodic replacements.

BRIEF SUMMARY OF THE INVENTION

There is provided in practice of this invention according to a preferred embodiment, semiconductive compositions selected from the Group consisting of:

Selenium with, from 4.85% to 5.5% Tellurium, from 3.95% to 4.2% Germanium, from 2.85% to 3.2% Neodymium, and from 2.0% to 2.5% Gallium.

Selenium with, from 4.8% to 5.5% Tellurium, from 3.9% to 4.5% Germanium, from 2.9% to 3.5% Neodymium and from 4.5% to 5% Rubidium, and

Germanium with, from 4.75% to 5.5% Tellurium, from 4.0% to 4.5% Neodymium and from 5.5% to 7.0% Rubidium.

DRAWINGS

These and other features and advantages of the invention will be appreciated and better understood by reference to the following detailed description of a preferred embodiment when considered in conjunction with the following drawings:

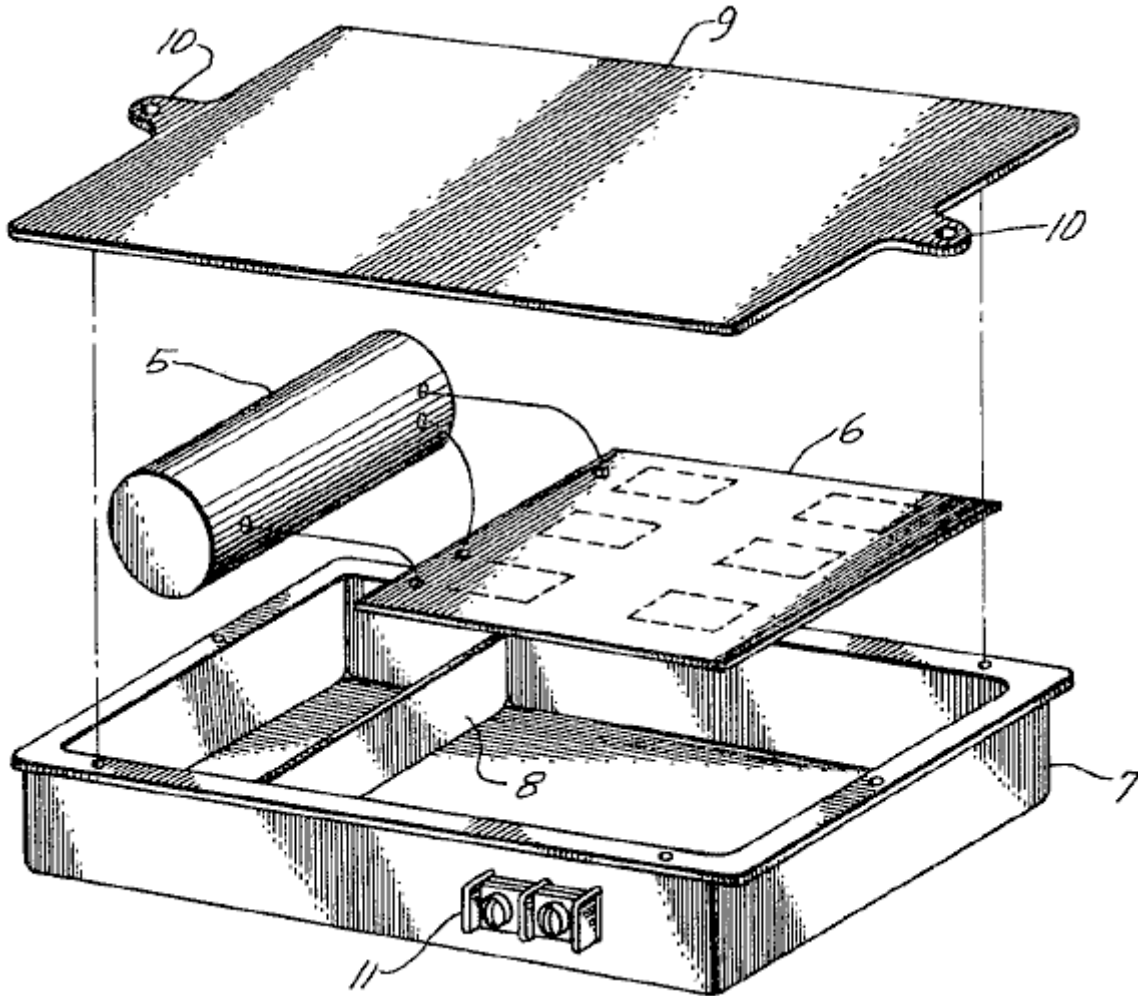

Fig.1 illustrates in exploded schematic, a flashing lamp connected to an electric power supply constructed according to the principles of this invention.

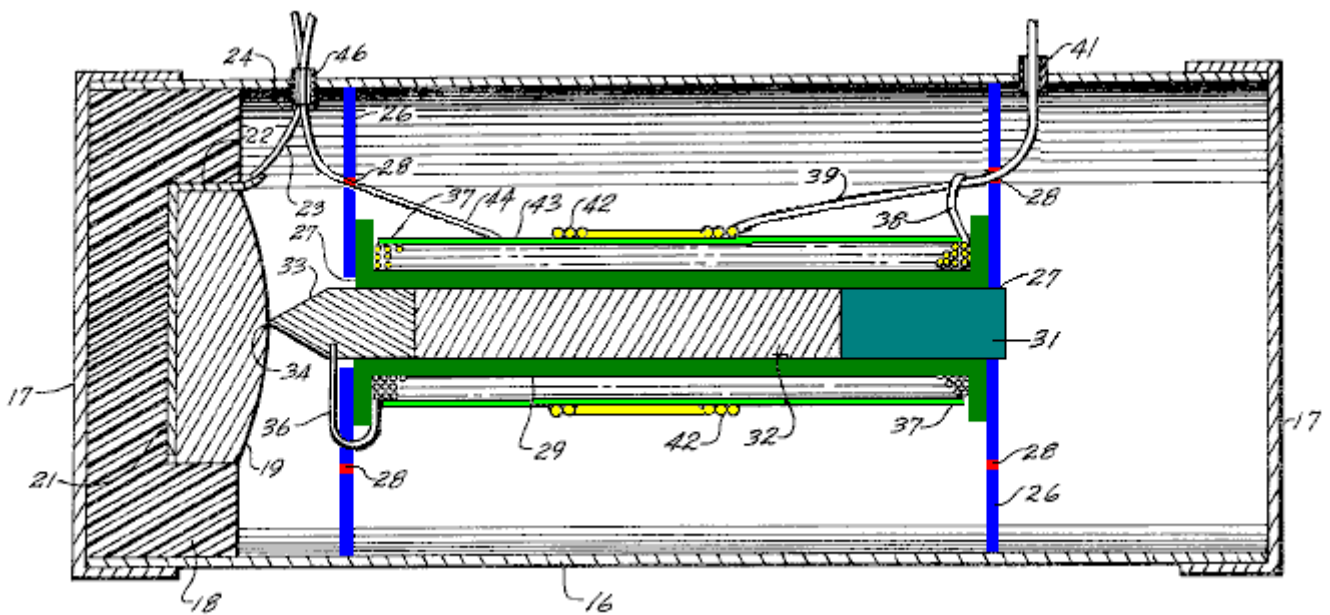

Fig.2 illustrates in longitudinal cross-section, the power pack of Fig.1

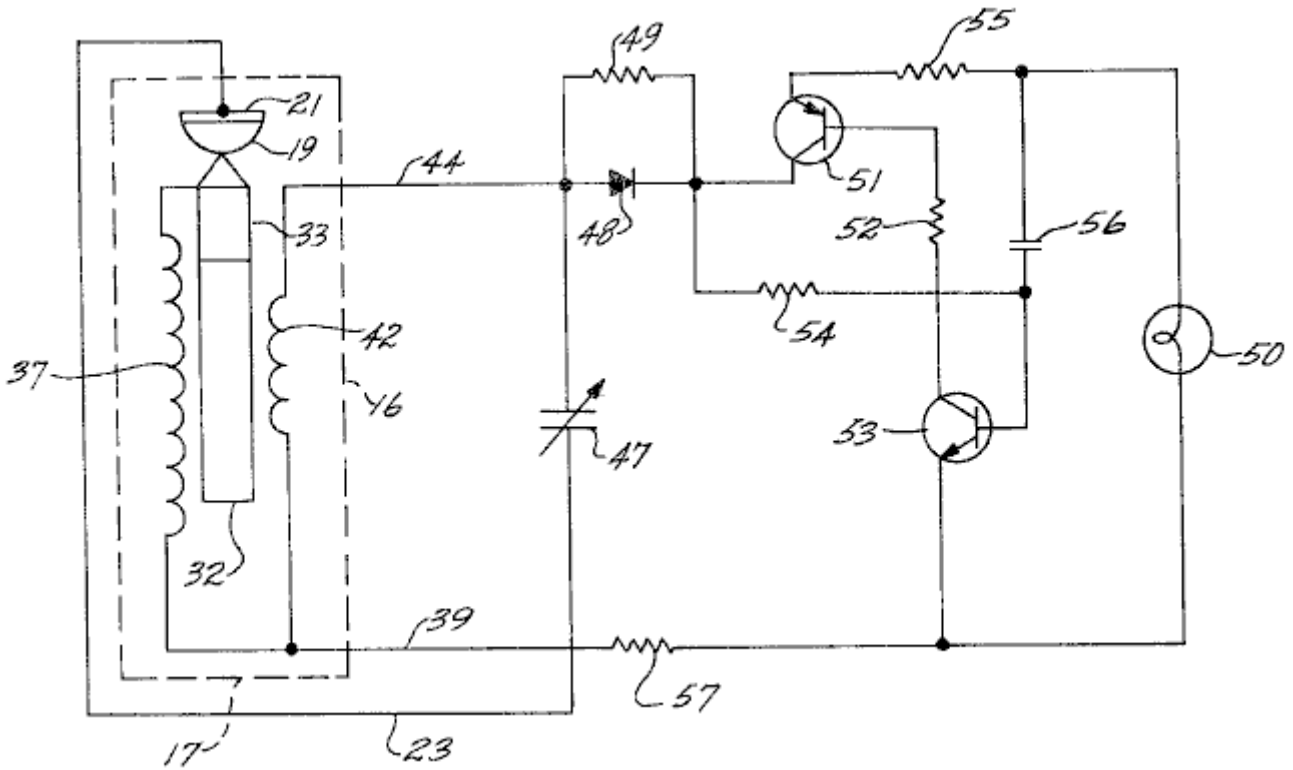

Fig.3 is an electric circuit diagram of the system.

DESCRIPTION

Fig.1 illustrates schematically, a typical flashing lamp having a power supply constructed according to the principles of this invention. As illustrated in this preferred embodiment, an electric power pack 5, is connected electrically to a relaxation oscillator circuit (shown only schematically) on a conventional printed-circuit board 6.

The power pack 5 and the printed-circuit board are mounted in a metal box 7, which has a transverse partial partition 8, which creates two spaces, one for the power pack and the other for the printed-circuit board which is prevented from contacting the metal box by any convenient insulating mounting. Preferably, these components are potted in place in a conventional manner.

A cover 9, having mounting lugs 10, is riveted on to the box after assembly. A small terminal strip 11, mounted on one side of the box 7, provides electrical contacts for connection to a load such as an incandescent lamp (not shown in Fig.1). the lamp provides a flash of light when the relaxation oscillator switches. Although the described system is employed for a flashing lamp, it will be apparent that other loads may be powered by the invention.

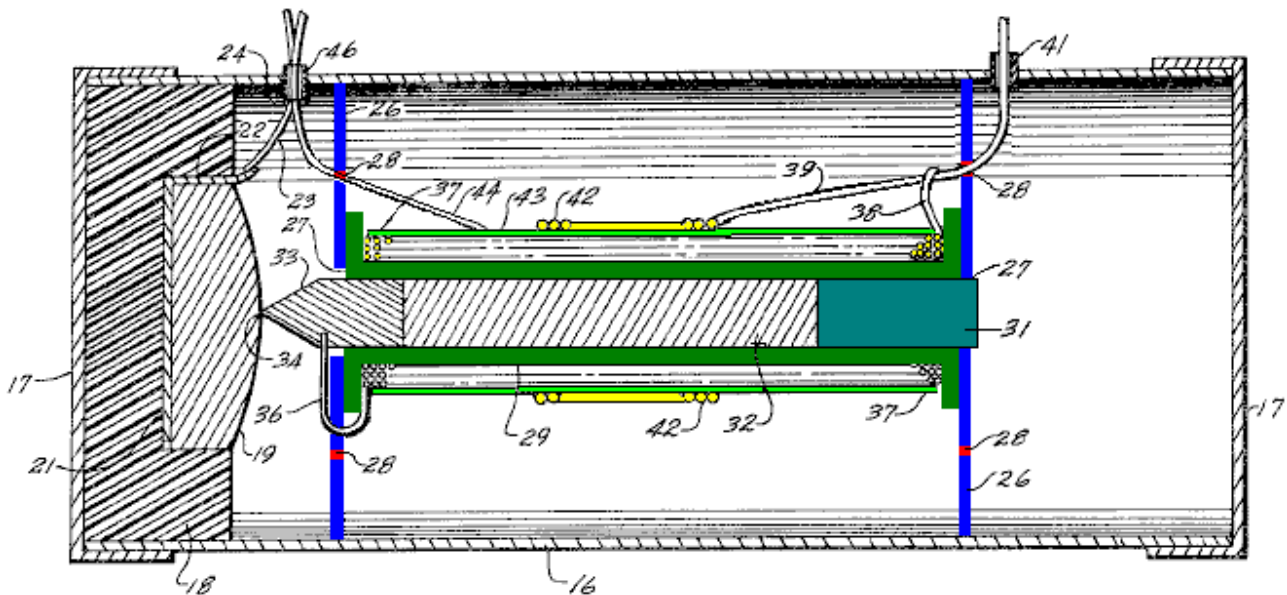

In **Fig.2**, the electric power pack **10**, is illustrated in longitudinal cross-section and has dimensions as follows: These dimensions are provided by way of example for powering a conventional flashing lamp and it will be clear that other dimensions may be used for other applications. In particular, the dimensions may be enlarged in order to obtain higher power levels and different voltage or current levels. The power pack is comprised of a cylindrical metal tube **16**, having closely fitting metal caps **17** at each end, which are preferably sealed to the tube after the internal elements are inserted in place. The metal tube **16** and caps **17**, which are preferably of aluminium, thus form a closed conductive envelope, which in a typical embodiment, has an inside diameter of about 0.8 inch and a length of about 2.25 inches.

Mounted within one end of the envelope is a plastic cup **18**, the dimensions of which are not critical, however, a wall thickness of at least 1/16 inch is preferred. Mounted within the plastic cup **18** is a semiconductor tablet **19** having a flat base and somewhat domed opposite side. The composition of the semiconductor tablet **19** is set out in greater detail below. Typically, the semiconductor tablet has a mass of about 3.8 grams. A metal disc **21** is positioned beneath the base of the tablet **19** in the cup **18**, and is preferably adhesively bonded inside the cup. The metal disc is tightly fitted to the base of the tablet so that good electrical contact is obtained over a substantial area of the semiconductor.

An ear **22** on one edge of the disc is soldered to a wire **23**, which extends through a short insulating sleeve **24** which passes through a hole in the side of the metal envelope. The insulating sleeve **24** acts as a grommet and ensures that there is no damage to the insulation of wire **23** and subsequent accidental short circuiting between the wire and the metal envelope. Preferably, the insulating sleeve **24** is sealed with a small amount of plastic cement or the like, in order to maintain clean air within the cylindrical envelope. Two other openings for leads through the tube **16**, as mentioned below, are also preferably sealed to maintain cleanliness within the envelope.

A pair of circular metal discs **26**, are fitted inside tube **16** and are preferably cemented in place to prevent shifting. The two discs **26**, are equally spaced from the opposite ends of the envelope and are spaced apart by slightly more than 1.15 inches. Each of the discs has a central aperture **27**, and there is a plurality of holes **28**, extending through the disc in a circular array midway between the centre of the disc and its periphery. The holes **28** are preferably in the size range of about 0.01 to 0.06 inch in diameter and there are 12 on each disc located at 30⁰ intervals around the circle.

The two discs **26** divide the interior of the cylindrical envelope into three chambers, and the pattern of holes **28** provides communication between the chambers and affects the electrical properties of the cavity. It is believed that the pattern of holes affects the inductive coupling between the cavities inside the envelope and influences the oscillations in them.

Although an arrangement of 12 holes at 30⁰ centres has been found particularly advantageous in the illustrated embodiment, it is found in other arrangements that a pattern of 20 holes at 18⁰ centres or a pattern of 8 holes at 45⁰ centres, provides optimum operation. In either case, the circle of holes **28** is midway between the centre and the periphery of the disc.

Mounted between the discs **26** is a plastic spool **29** which has an inside distance of 1.1 inches between its flanges. The plastic spool **29** preferably has relatively thin walls and an internal bore diameter of 1/8 inch. A plastic mounting plug **31**, is inserted through the central aperture **27** of the disc **26** farthest from the semiconductor table **19**, and into the bore of the spool **29**. The plastic plug **31** is preferably cemented to the disc **26** in order to hold the assembly together.

Also mounted inside the bore of spool **29** is a cylindrical ferrite core **32**, about 1/8 inch diameter and 3/4 inch long. Although a core of any magnetic ferrite is preferred, other ferromagnetic materials having similar properties can be used if desired. The core **32**, is in electrical contact with a metal probe **33** about 1/4 inch long. half of the length of the probe **33** is in the form of a cylinder positioned within the spool **29**, and the other half is in the form of a cone ending in a point **34** in contact with the domed surface of the semiconductor tablet **19** where it makes an electrical contact with the semiconductor in a relatively small point.

Electrical contact is also made with the probe **33** by a lead **36**, which passes through one of the holes **28** in the disc **26** nearer to the semiconductor tablet and thence to a primary coil **37**, wound on the plastic spool **29**. The primary coil **37** is in the form of 800 to 1000 turns wound along the length of the spool, and the lead **38** at the opposite end of the coil **37** is soldered to one of the external leads **39** of the power pack. This lead **39** proceeds through one of the holes **28** in the disc farthest from the semiconductor tablet **19**, and through an insulating sleeve **41** in the metal tube **16**.

The lead **39** is also connected to one end of a secondary coil **42** which is composed of 8 to 10 turns around the centre portion of the primary coil **37**. A thin insulating sheet **43** is provided between the primary and secondary coils. The other lead **44** from the secondary coil passes through one of the holes **28** in the disk nearer the semiconductor tablet and thence through an insulating sleeve **46** through the wall of the tube **16**.

Fig.3 illustrates schematically, the electrical circuit employing an electric power pack constructed according to the principles of this invention. At the left hand side of **Fig.3**, the arrangement of elements is illustrated in a combination of electrical schematic and mechanical position inside tube **16** for ready correlation with the embodiment illustrated in **Fig.2**. Thus, the semiconductor tablet **19**, probe **33** and ferrite core **32** are shown in both their mechanical and electrical arrangement, the core being inductively coupled to the coils **37** and **42**. The lead **23** from the metal base of the semiconductor tablet **19**, is connected to a variable capacitor **47**, the other side of which is connected to the lead **44** from the secondary coil **42**. The lead **44** is also connected to a rectifying diode **48** shunted by a high value resistor **49**.

It will be seen that the variable capacitor **47** is in a tank circuit with the inductive coils **37** and **42** which are coupled by the ferrite core **32**, and this circuit also includes the semiconductor tablet **19** to which point contact is made by the probe **33**. The mechanical and electrical arrangement of these elements provides a resonant cavity in which resonance occurs when the capacitor **47** is properly trimmed. The diode **48**, rectifies the oscillations in this circuit to provide a suitable DC for operating an incandescent lamp **50** or similar load.

The rectifying diode **48** is connected to a complementary-symmetry relaxation circuit for switching power to the load **50**. The diode is connected directly to the collector of a PNP transistor **51** which is in an inverted connection. the emitter of the PNP transistor is connected to one side of the load **50** by way of a timing resistor **55**. The base of the transistor **51** is connected by way of a resistor **52** and a capacitor **56** to the collector of an NPN transistor **53**, the emitter of which is connected to the other side of the load **50**. The base of the NPN transistor **53** is coupled to the diode by a resistor **54**. The emitter of the PNP transistor **51** is fed back to the base of the NPN transistor **53** by the resistor **55**. Current flow through the lamp **50** is also limited by a resistor **57** which couples one side of the lamp and the emitter of the NPN transistor **53** to the two coils **37** and **42** by way of the common lead **39**.

The electrical power pack is believed to operate due to a resonance amplification once an oscillation has been initiated in the cavity, particularly the central cavity between the discs **26**. This oscillation, which apparently rapidly reaches amplitudes sufficient for useful power, is then half-wave rectified for use by the diode **48**. With such an arrangement, a voltage level of several volts has been obtained, and power sufficient for intermittent operation of a lamp requiring about 170 to 250 milliwatts has been demonstrated. The resonant amplification is apparently due to the geometrical and electrical combination of the elements, which provide inductive coupling of components in a suitable resonant circuit. This amplification is also, at least in part, due to unique semiconductor properties in the tablet **19**, which has electronic properties due to a composition giving a unique atomic arrangement, the exact nature of which has not been measured.

The semiconductor tablet has electronic properties which are determined by its composition and three such semiconductors satisfactory for use in the combination have been identified. In two of these, the base semiconductor material is selenium provided with suitable dopant elements, and in the third, the base element is germanium, also suitably doped. The semiconductor tablets are made by melting and casting in an arrangement which gives a large crystal structure. It has not been found necessary to provide a selected crystal orientation in order to obtain the desired effects.

A preferred composition of the semiconductor includes about 5% by weight of tellurium, about 4% by weight of germanium, about 3% by weight of neodymium and about 4.7% by weight of rubidium, with the balance of the composition being selenium. Such a composition can be made by melting these materials together or by dissolving the materials in molten selenium.

Another highly advantageous composition has about 5% by weight of tellurium, about 4% by weight of germanium, about 3% by weight of neodymium, and about 2.24% by weight of gallium, with the balance being selenium. In order to make this composition, it is found desirable to add the very low melting point gallium in the form of gallium selenide rather than elemental gallium.

A third suitable composition has about 5% by weight of tellurium, about 4% by weight of neodymium, about 6% by weight of rubidium, with the balance being germanium. These preferred compositions are not absolute and it has been found that the level of dopant in the compositions can be varied within limits without significant loss of performance. Thus, it is found that the proportion of tellurium in the preferred composition can range from about 4.8% to about 5.5% by weight; the germanium can range from about 3.9% to 4.5% by weight; neodymium can range from about 2.9% to 3.5% by weight, and rubidium can vary from about 4.5% to 5.0% by weight. The

balance of the preferred composition is selenium although it has also been found that nominal impurity levels can be tolerated and no great care is required in preventing minor contamination.

The other selenium base composition useful in practice of this invention can have a tellurium concentration in the range of from about 4.85% to 5.5% by weight, germanium in the range of from about 3.95% to 4.2% by weight, neodymium in the range of from about 2.85% to 3.2% by weight, and gallium in the range of from about 2.0% to 2.5% by weight. As in the preferred composition, the balance is selenium and nominal impurity levels can be tolerated. It is preferred to add the gallium in the form of gallium selenide rather than as elemental gallium with a corresponding decrease in the selenium used to make up the composition.

The above selenium base compositions are easier to make and less expensive than the germanium base composition and are therefore preferable for most applications. It is found that these are particularly suited for relatively small semiconductor tablets up to about 1 inch or a little less. For relatively large tablets, it is preferred to use the germanium base composition.

The germanium base composition has a tellurium level in the range of from about 4.75% to 5.5% by weight, neodymium in the range of from about 4.0% to 4.5% by weight, and rubidium in the range of from about 5.5% to 7.4% by weight. It is also found that it is of greater importance to maintain purity of the germanium base compositions than the selenium base compositions. Although the exact purity levels have not been ascertained, it is in excess of 99%.

It has been found that it is not necessary to have single crystals in the semiconductor tablets and any convenient grain size in excess of about 1 millimetre appears satisfactory. In the above compositions, when the recited ranges are exceeded, oscillation in the power pack drops off rapidly and may cease altogether.

The reasons that these compositions are satisfactory in the arrangement providing resonance amplification has not been determined with certainty. It is possible that the semiconductor serves as a source of electrons for providing an oscillating current in the circuit. This is, of course, combined with a relatively large area contact to one side of the semiconductor tablet, and a point contact on another area. Any resonant current in the coils wound on the ferrite rod, induces a varying magnetic field in the resonant cavity, and the electrical connection between the ferrite rod and the metal probe, provides a feedback of this oscillation to the semiconductor tablet.

it should particularly be noted that the oscillation in the circuit does not commence until it is initiated by an oscillating signal. In order to accomplish this, it is only necessary to apply a few millivolts of AC for a few seconds to the semiconductor tablet and the associated coils coupled to it. The initial signal applied to the base of the semiconductor tablet and the lead 39 is preferably in the frequency range of 5.8 to 18 Mhz and can be as high as 150 Mhz. Such a signal can be applied from any conventional source and no great care appears necessary to provide a single frequency signal or to eliminate noise. Once such energisation has been applied to the circuit and oscillations initiated, it does not appear to be necessary to apply such a signal again. This is apparently due to the feedback provided by the ferrite rod to the probe which makes contact with the semiconductor tablet.

Energy is, of course, dissipated in the lamp, or other utilisation device, as the combination operates. Such energy may come from deterioration of the semiconductor tablet as oscillations continue; however, if there is any such deterioration, it is sufficiently slow that a power source may be operated for many months without attendance. Such a source of energy may be augmented by ambient Radio Frequency radiation, coupled into the resonant cavity by the external leads. This is a surprising phenomenon because the leads are small compared to what would normally be considered an adequate antenna, and it is therefore postulated that stimulated amplification may also be a consequence of the unique electronic configuration of the semiconductors having the compositions specified above.

Although only one embodiment of electric power pack constructed according to principles of this invention has been described and illustrated here, many modifications and variations will be apparent to one skilled in the art. Thus, for example, a larger power pack may be axially arranged in a cylindrical container with various electronic elements arranged in the annular space. It is therefore to be understood that other configurations are included within the scope of the invention.

EDWIN GRAY

US Patent 3,890,548

June 17, 1975

Inventor: Edwin V. Gray snr.



PULSED CAPACITOR DISCHARGE ELECTRIC ENGINE

Please note that this is a re-worded extract from Edwin Gray's Patent 3,890,548. It describes his high voltage motor and the circuitry used to drive it. Please be aware that the underlying technology was developed by Marvin Cole and Edwin Gray did not understand it. Also, Edwin wanted at all costs to conceal any useful technology while getting patents to encourage investors, so please understand that this patent is not intended to tell you how to make a working system of this type.

SUMMARY OF THE INVENTION:

This invention relates to electric motors or engines, and more particularly to a new electric machine including electromagnetic poles in a stator configuration and electromagnetic poles in a rotor configuration, wherein in one form thereof, the rotor is rotatable within the stator configuration and where both are energised by capacitor discharges through rotor and stator electromagnets at the instant of the alignment of a rotor electromagnet with a stator electromagnet. The rotor electromagnet is repelled from the stator electromagnet by the discharge of the capacitor through the coils of both the rotor and stator electromagnets at the same instant.

In an exemplary rotary engine according to this invention, rotor electromagnets may be disposed 120 degrees apart on a central shaft and major stator electromagnets may be disposed 40 degrees apart in the motor housing about the stator periphery. Other combinations of rotor elements and stator elements may be utilised to increase torque or rate of rotation.

In another form, a second electromagnet is positioned to one side of each of the major stator electromagnets on a centreline 13.5 degrees from the centreline of the stator magnet, and these are excited in a predetermined pattern or sequence. Similarly, to one side of each rotor electromagnet, is a second electromagnet spaced on a 13.5 degree centreline from the major rotor electromagnet. Electromagnets in both the rotor and stator assemblies are identical, the individual electromagnets of each being aligned axially and the coils of each being wired so that each rotor electromagnetic pole will have the same magnetic polarity as the electromagnet in the stator with which it is aligned and which it is confronting at the time of discharge of the capacitor.

Charging of the discharge capacitor or capacitors is accomplished by an electrical switching circuit wherein electrical energy from a battery or other source of d-c potential is derived through rectification by diodes.

The capacitor charging circuit comprises a pair of high frequency switchers which feed respective automotive-type ignition coils employed as step-up transformers. The "secondary" of each of the ignition coils provides a high voltage square wave to a half-wave rectifier to generate a high voltage output pulse of d-c energy with each switching alternation of the high frequency switcher. Only one polarity is used so that a unidirectional pulse is applied to the capacitor bank being charged.

Successive unidirectional pulses are accumulated on the capacitor or capacitor bank until discharged. Discharge of the bank of capacitors occurs across a spark gap by arc-over. The gap spacing determines the voltage at which discharge or arc-over occurs. An array of gaps is created by fixed elements in the engine housing and moving elements positioned on the rotor shaft. At the instant when the moving gap elements are positioned

opposite fixed elements during the rotor rotation, a discharge occurs through the coils of the aligned rotor and stator electromagnets to produce the repulsion action between the stator and rotor electromagnet cores.

A plurality of fixed gap elements are arrayed in a motor housing to correspond to the locations of the stator electromagnets in the housing. The rotor gap elements correspond to the positions of the rotor electromagnets on the rotor so that at the instant of correct alignment of the gaps, the capacitors are discharged to produce the necessary current through the stator and rotor coils to cause the electromagnets to repel one another.

The charging circuits are arranged in pairs, and are such that the discharge occurs through both rotor and stator windings of the electromagnets, which are opposite one another when the spark gap elements are aligned and arc-over.

The speed of the rotor can be changed by means of a clutch mechanism associated with the rotor. The clutch shifts the position of the rotor gap elements so that the discharge will energise the stator coils in a manner to advance or retard the time of discharge with respect to the normal rotor/stator alignment positions. The discharge through the rotor and stator then occurs when the rotor has passed the stator by 6.66 degrees for speed advance.

By causing the discharge to occur when the rotor position is approaching the stator, the repulsion pulse occurs 6.66 degrees before the alignment position of the rotor and stator electromagnets, thus reducing the engine speed.

The clutch mechanism for aligning capacitor discharge gaps for discharge is described as a control head. It may be likened to a firing control mechanism in an internal combustion engine in that it "fires" the electromagnets and provides a return of any discharge overshoot potential back to the battery or other energy source.

The action of the control head is extremely fast. From the foregoing description, it can be anticipated that an increase in speed or a decrease in speed of rotation can occur within the period in which the rotor electromagnet moves between any pair of adjacent electromagnets in the stator assembly. These are 40 degrees apart so speed changes can be effected in a maximum of one-ninth of a revolution.

The rotor speed-changing action of the control head and its structure are believed to be further novel features of the invention, in that they maintain normal 120 degree firing positions during uniform speed of rotation conditions, but shift to 6.66 degree longer or shorter intervals for speed change by the novel shift mechanism in the rotor clutch assembly.

Accordingly, the preferred embodiment of this invention is an electric rotary engine wherein motor torque is developed by discharge of high potential from a bank of capacitors, through stator and rotor electromagnet coils when the electromagnets are in alignment. The capacitors are charged from batteries by a switching mechanism, and are discharged across spark gaps set to achieve the discharge of the capacitor charge voltage through the electromagnet coils when the gaps and predetermined rotor and stator electromagnet pairs are in alignment.

Exemplary embodiments of the invention are herein illustrated and described. These exemplary illustrations and description should not be construed as limiting the invention to the embodiments shown, because those skilled in the arts appertaining to the invention may conceive of other embodiments in the light of the description within the ambit of the appended claims.

BRIEF DESCRIPTION OF THE DRAWINGS:

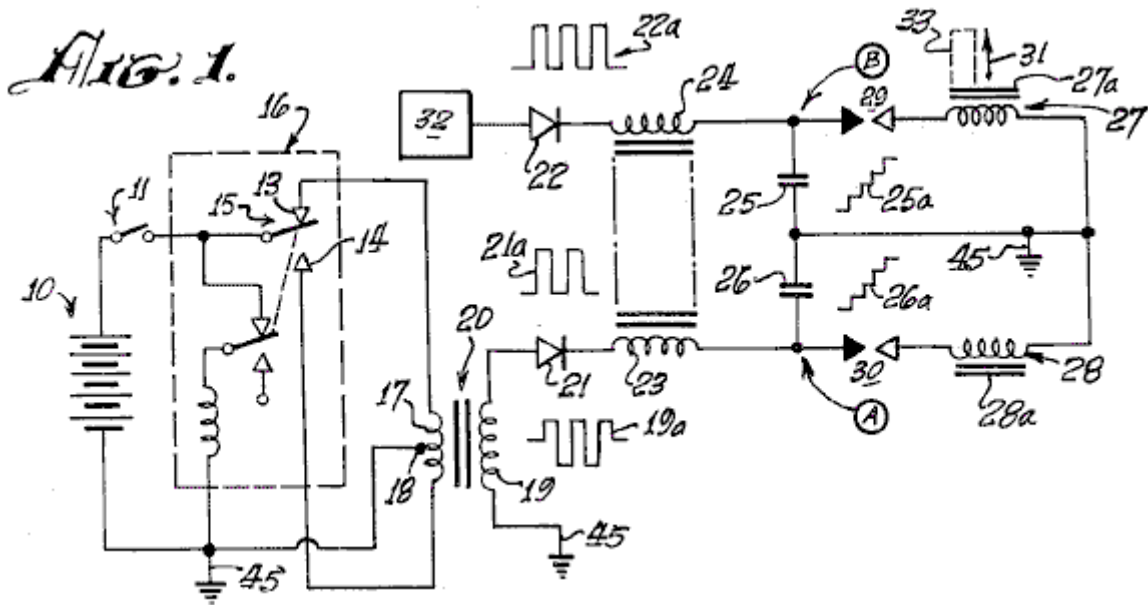

Fig.1 is an explanatory schematic diagram of a capacitor charging and discharging circuit utilised in the present invention.

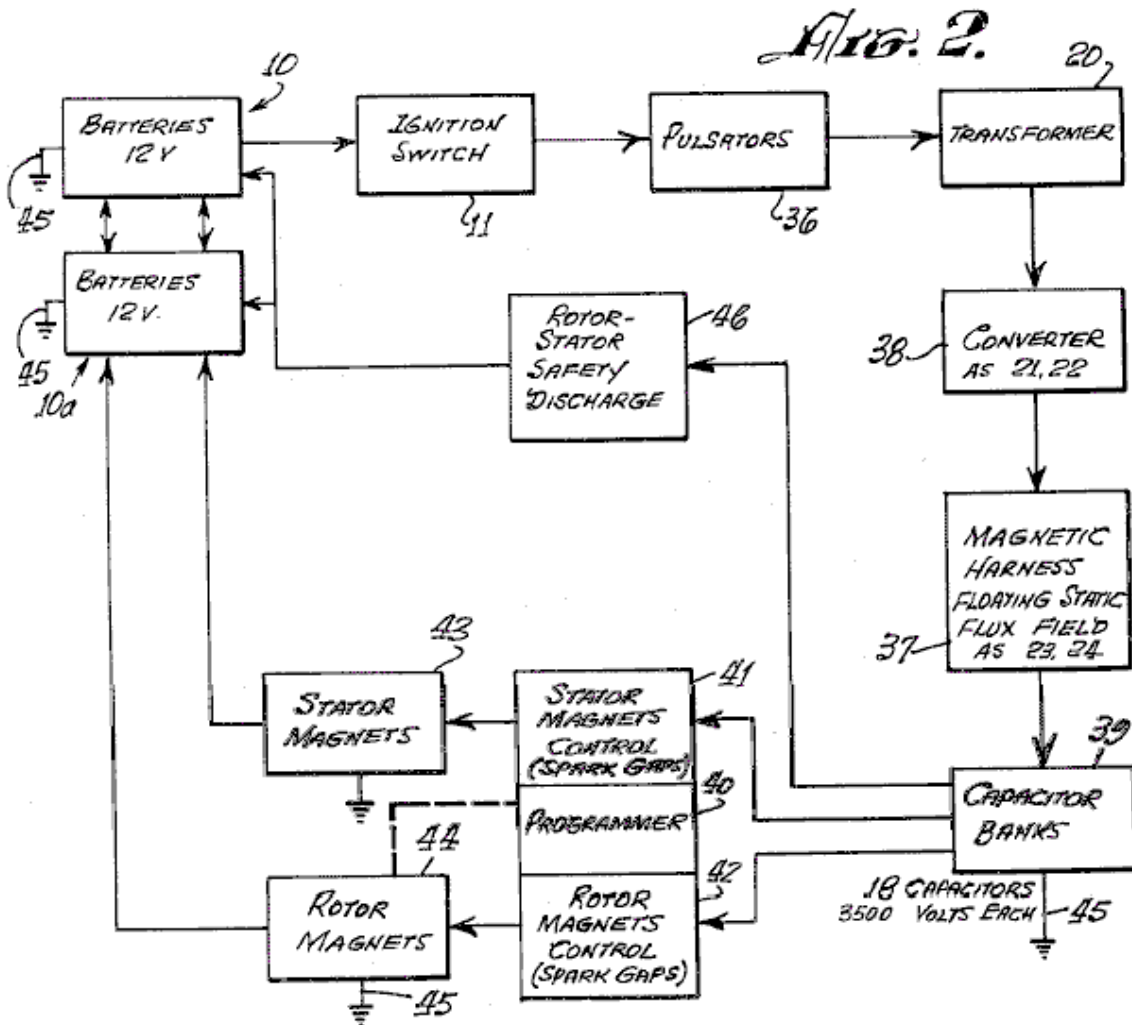

Fig.2 is a block diagram of an exemplary engine system according to the invention.

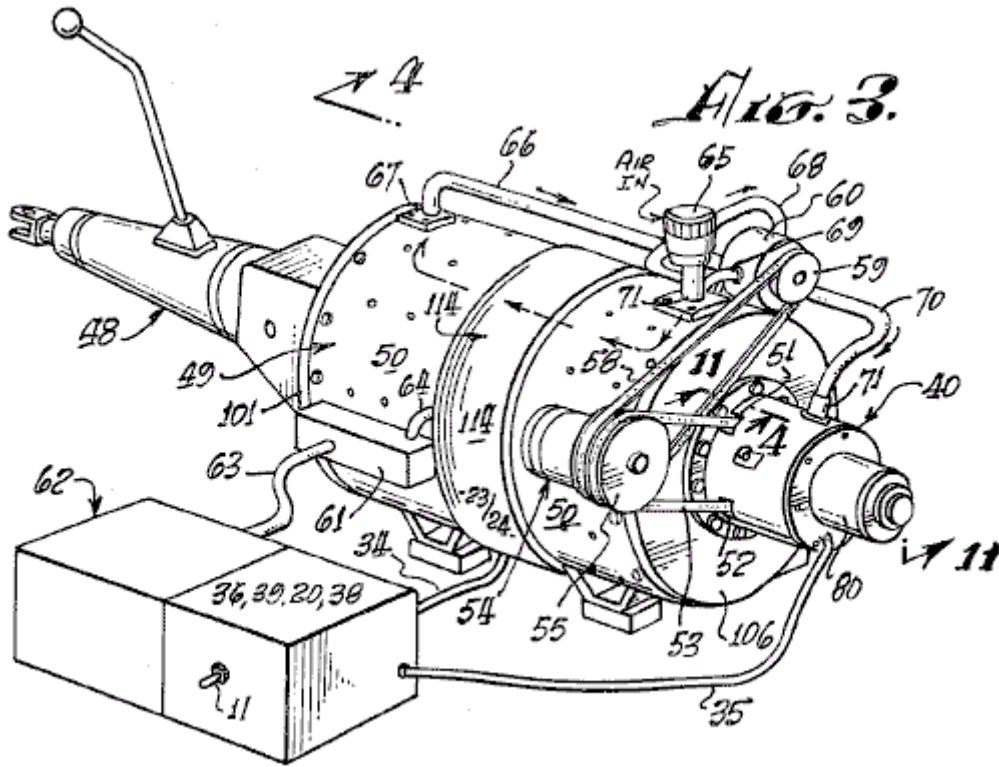

Fig.3 is a perspective view of a typical engine system according to the invention, coupled to an automotive transmission.

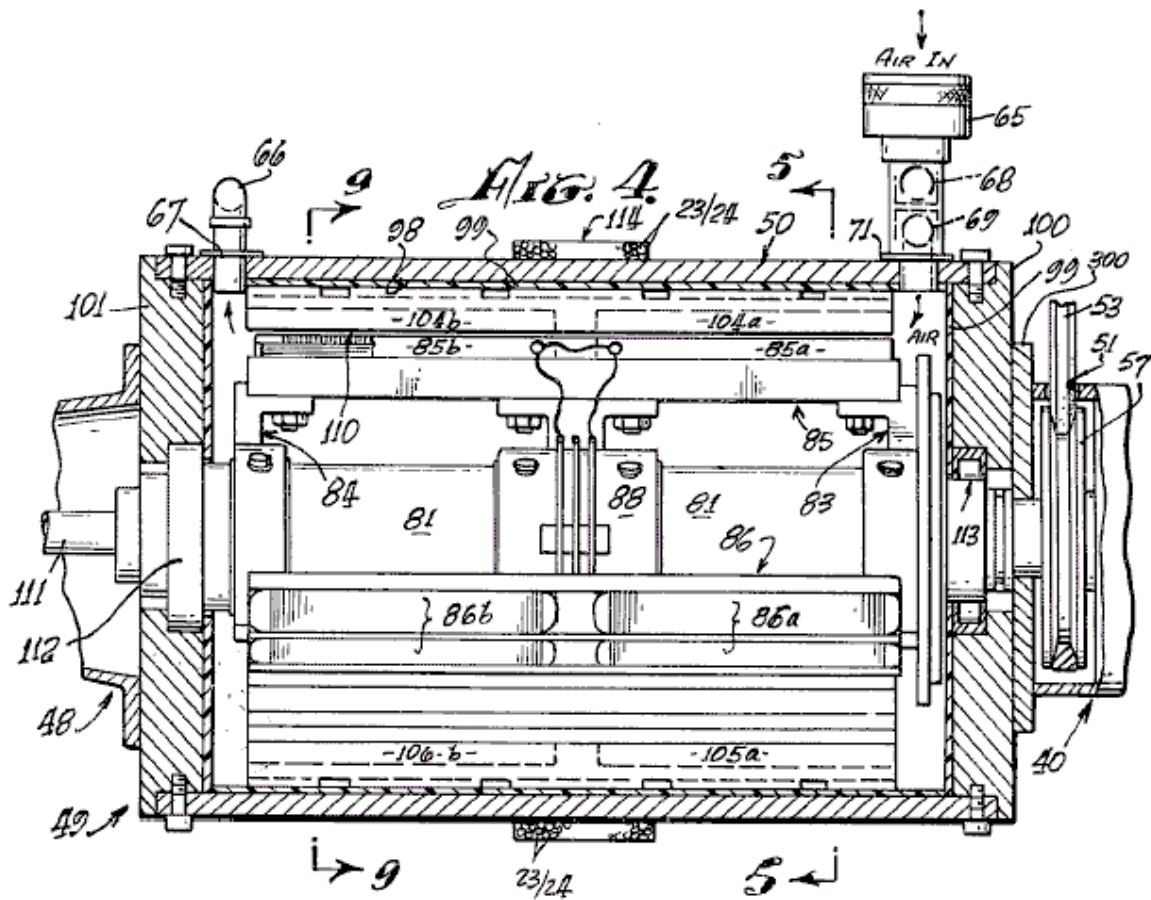

Fig.4 is an axial sectional view taken at line 4---4 in Fig.3

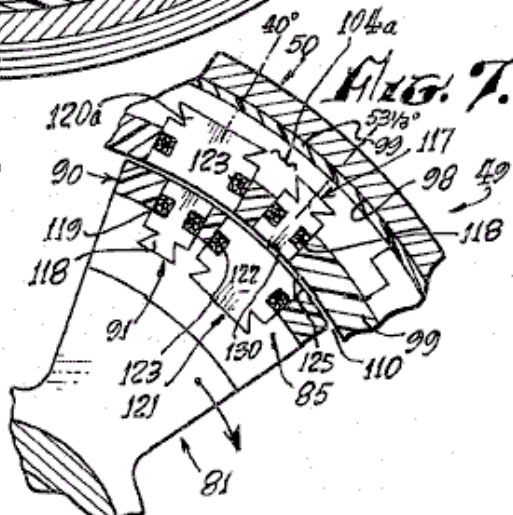
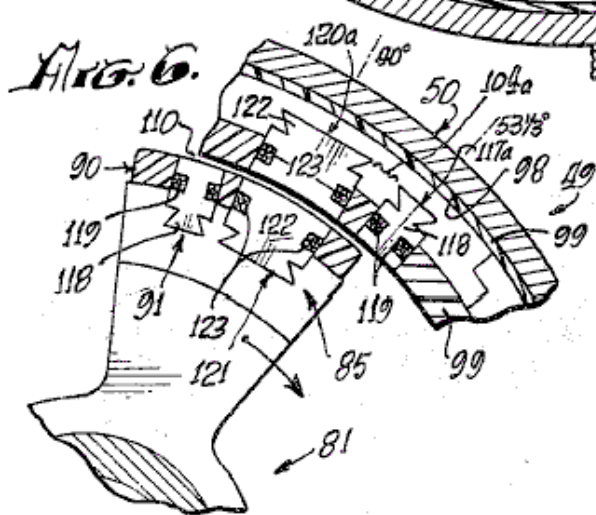
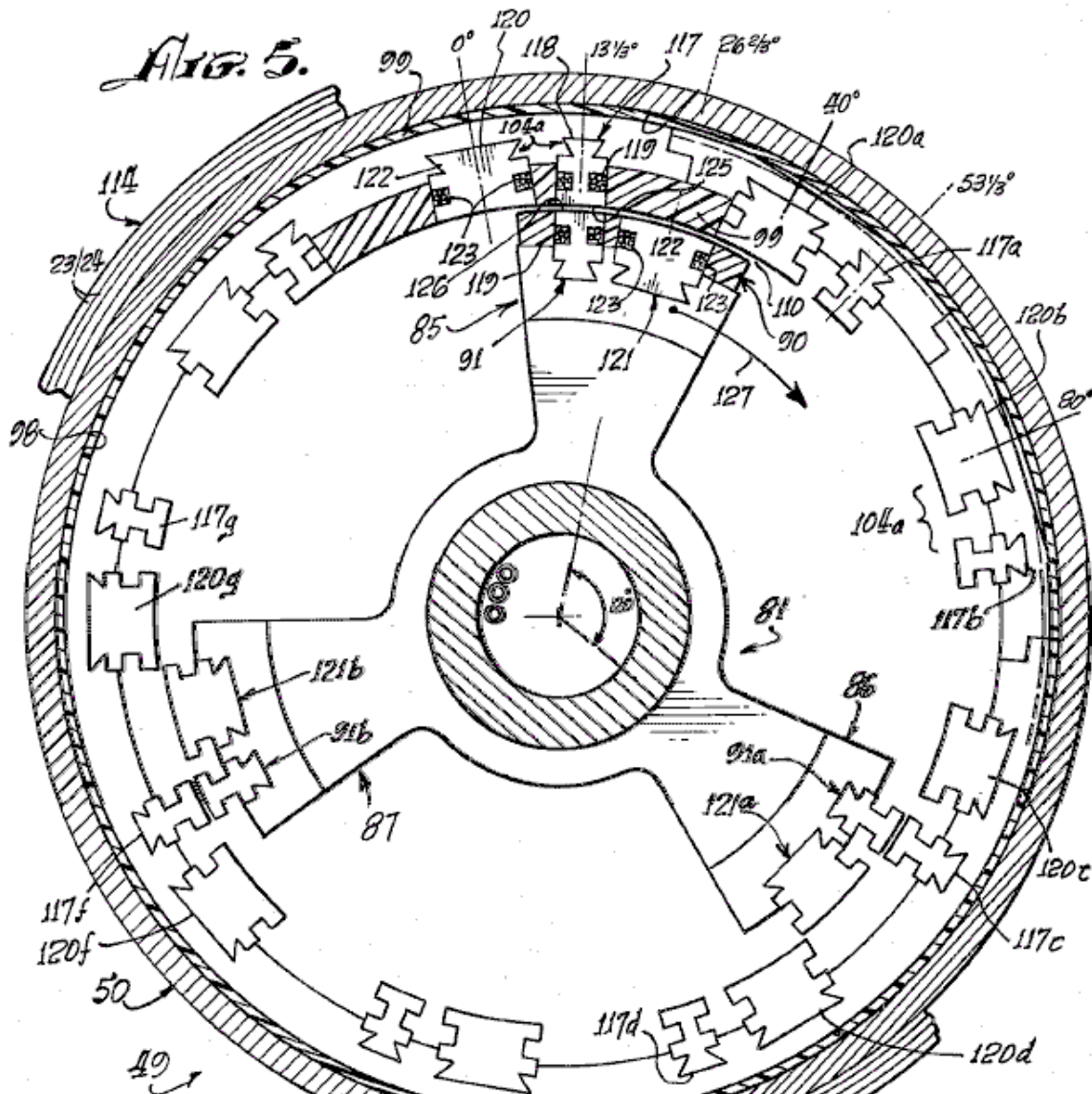

Fig. 5 is a sectional view taken at line 5---5 in Fig. 4

Fig. 6 and Fig. 7 are fragmentary sectional views, corresponding to a portion of Fig. 5, illustrating successive advanced positions of the engine rotor therein.

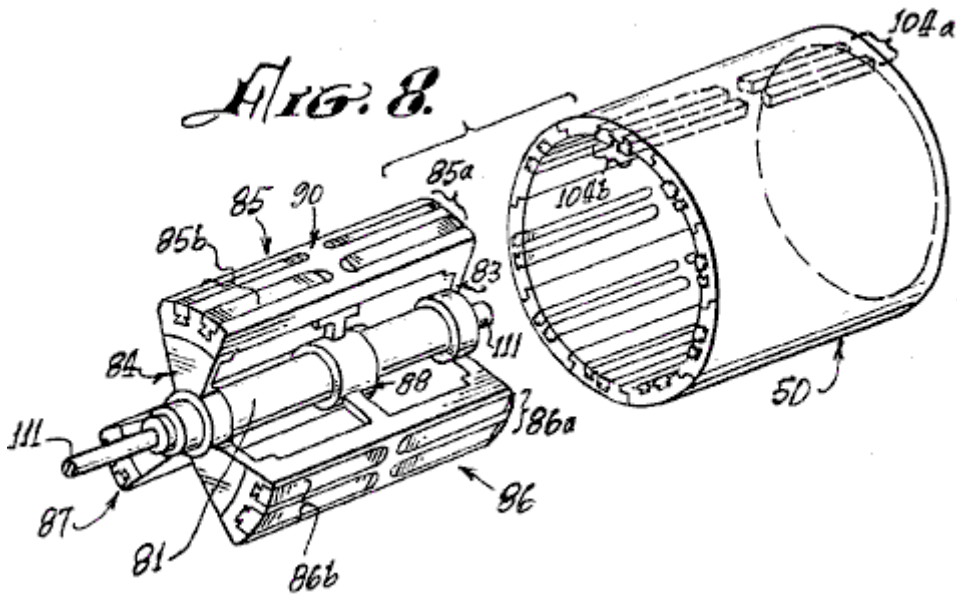

Fig.8 is an exploded perspective view of the rotor and stator of the engine of Fig.3 and Fig.4

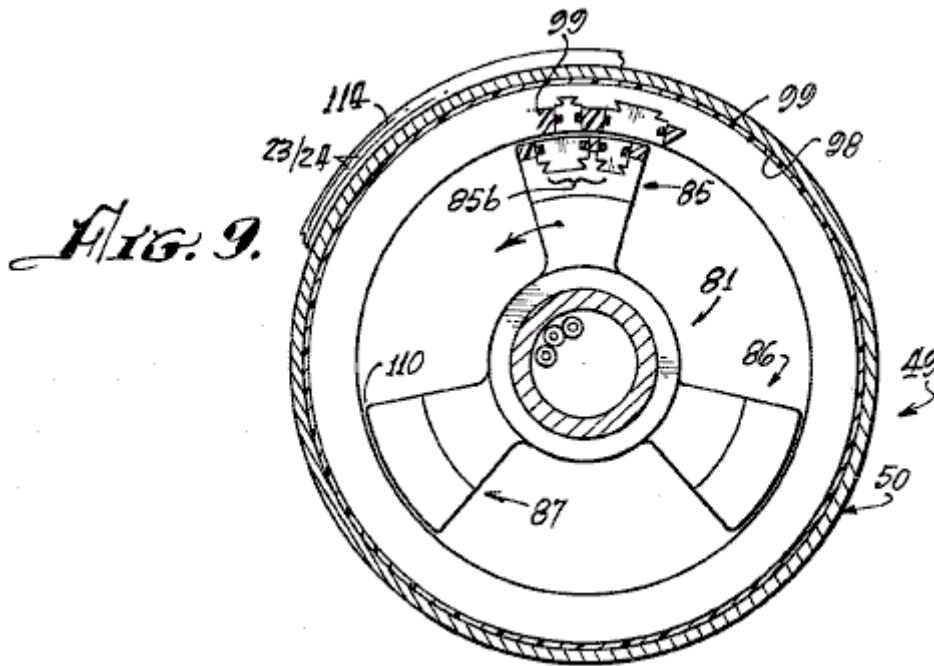

Fig.9 is a cross-sectional view taken at line 9---9 of Fig.4

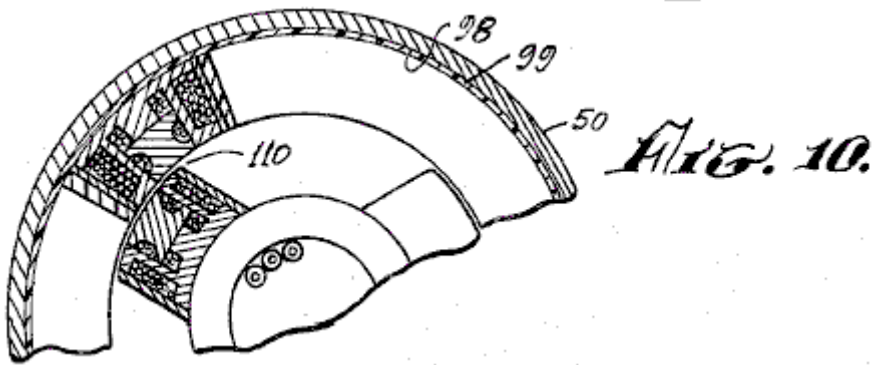

Fig.10 is a partial sectional view, similar to the view of Fig.9, illustrating a different configuration of electromagnets in another engine embodiment of the invention.

FIG. 11.

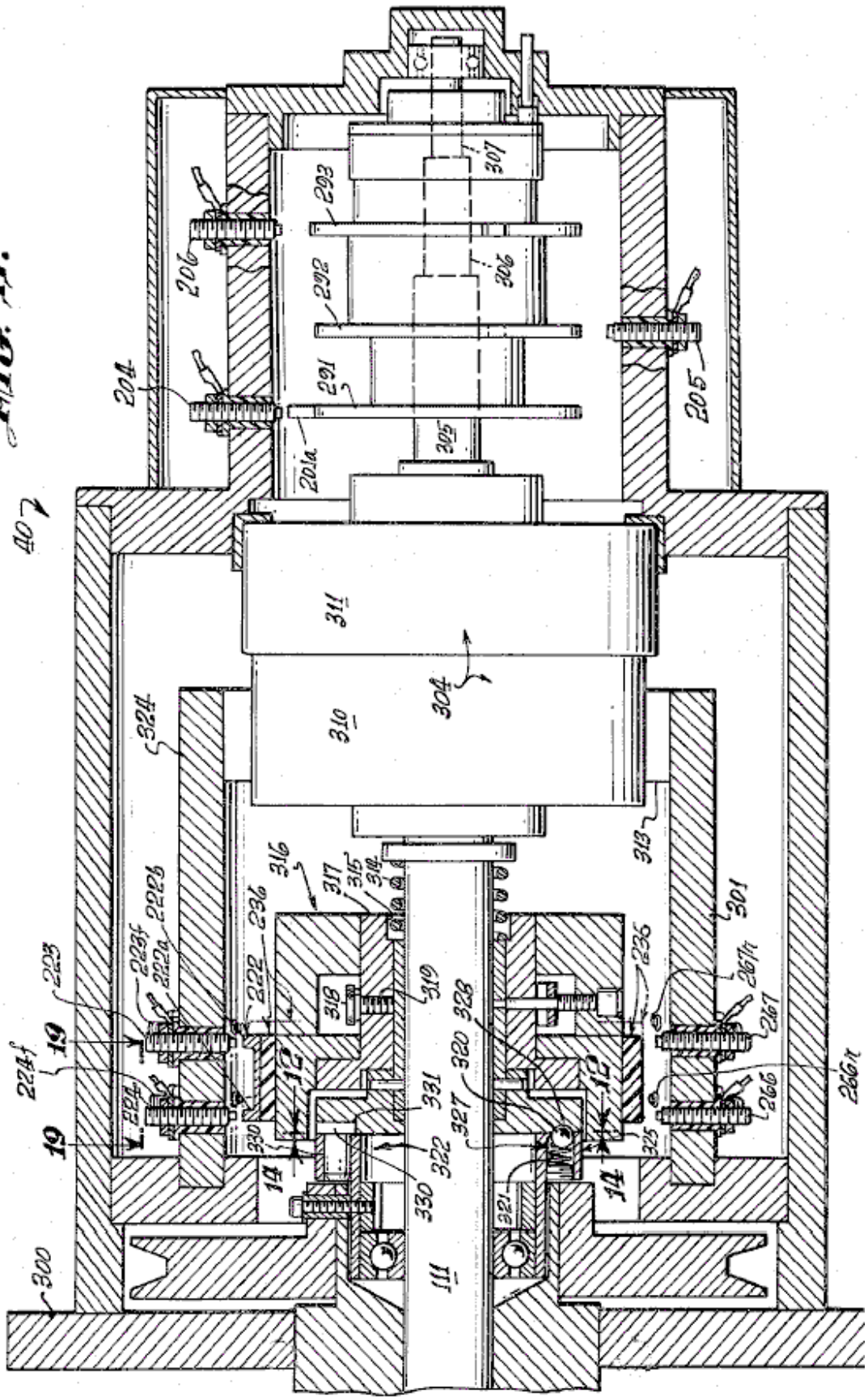

Fig.11 is a sectional view taken at line 11---11 in Fig.3, illustrating the control head or novel speed change controlling system of the engine.

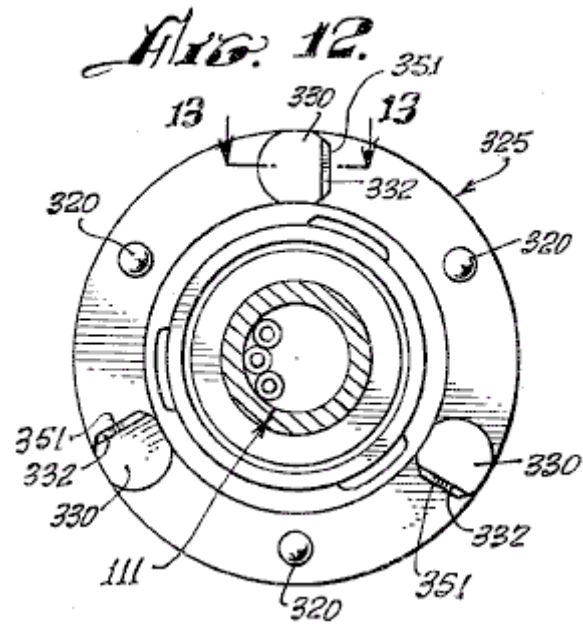

Fig.12 is a sectional view, taken at line 12---12 in Fig.11, showing a clutch plate utilised in the speed change control system of Fig.11

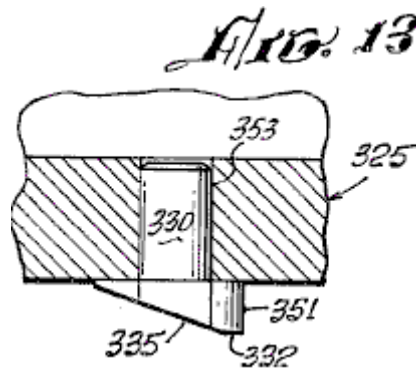

Fig.13 is a fragmentary view, taken at line 13---13 in Fig.12

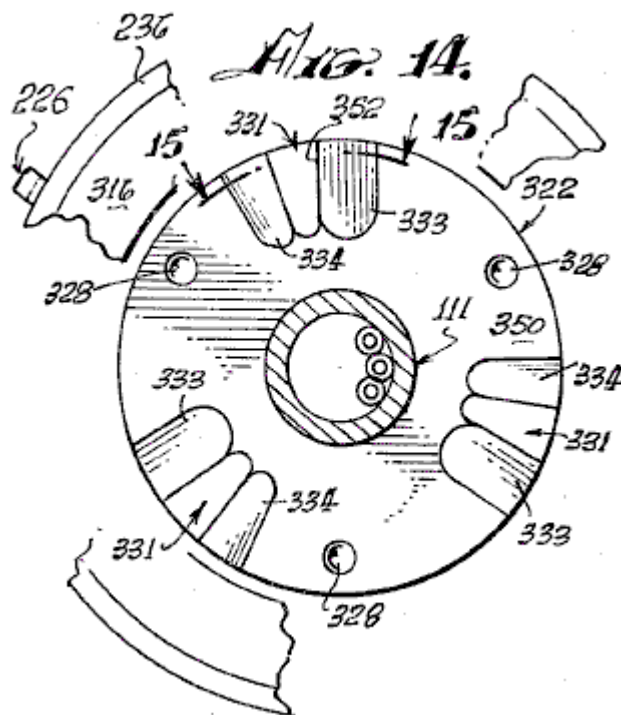

Fig.14 is a sectional view, taken at line 14---14 in Fig.11, showing a clutch plate which co-operates with the clutch plate of Fig.12

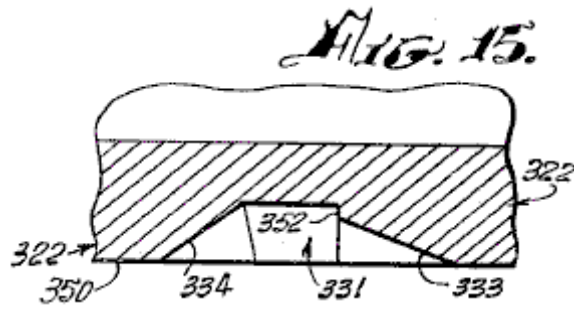

Fig.15 is a fragmentary sectional view taken at line 15---15 of Fig.13

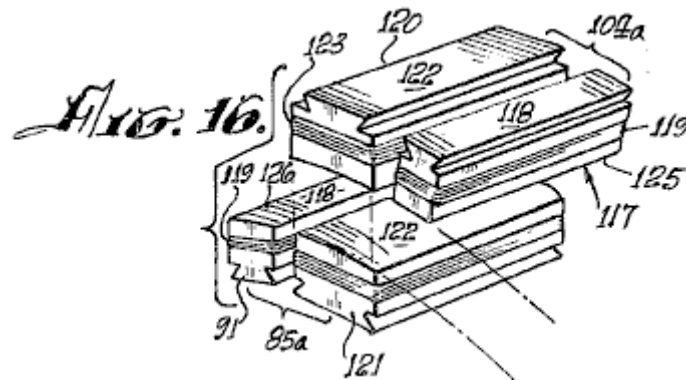

Fig.16 is a perspective view of electromagnets utilised in the present invention.

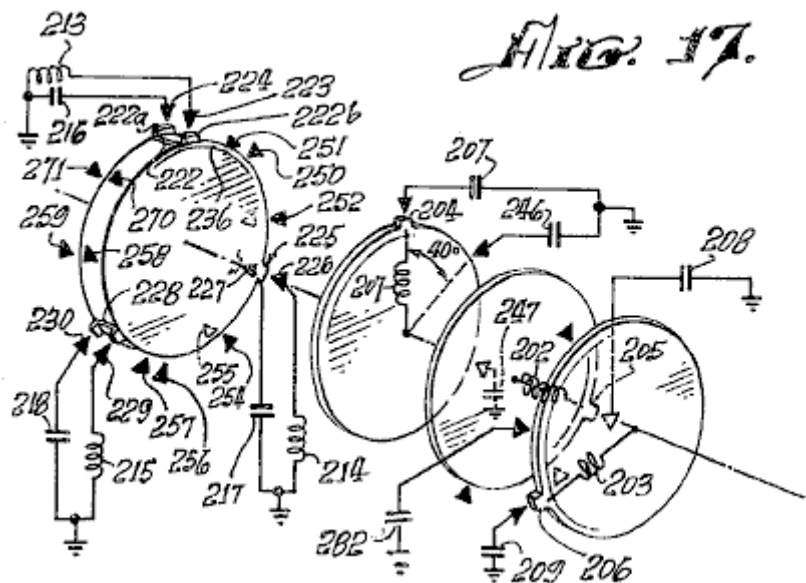

Fig.17 is a schematic diagram showing co-operating mechanical and electrical features of the programmer portion of the invention.

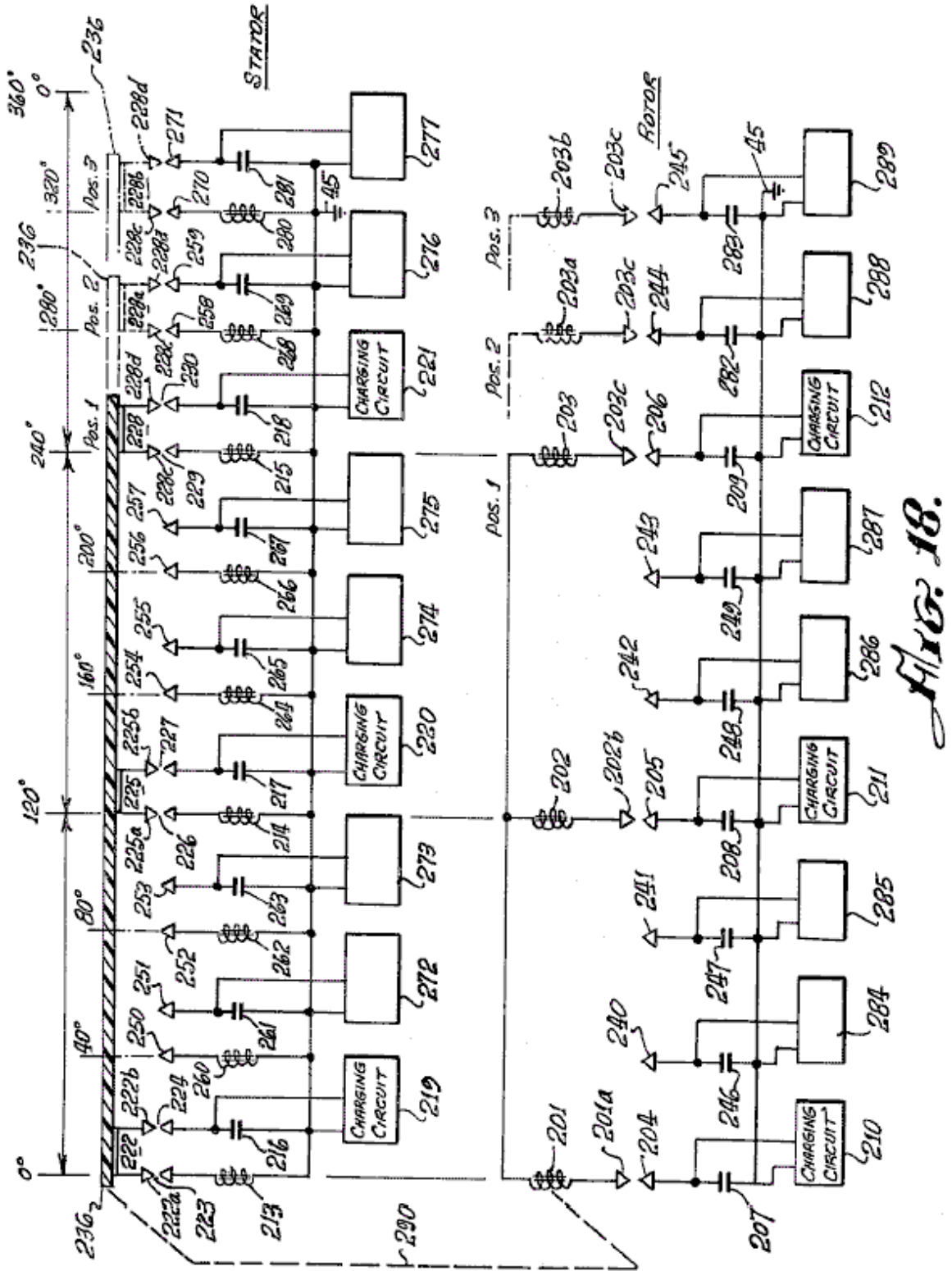

Fig.18 is an electrical schematic diagram of an engine according to the invention, showing the electrical relationships of the electromagnetic components embodying a new principle of the invention, and

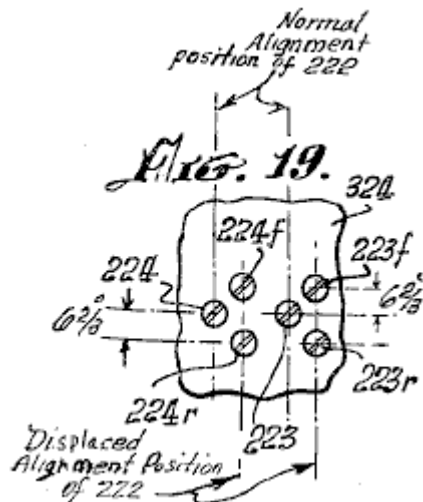
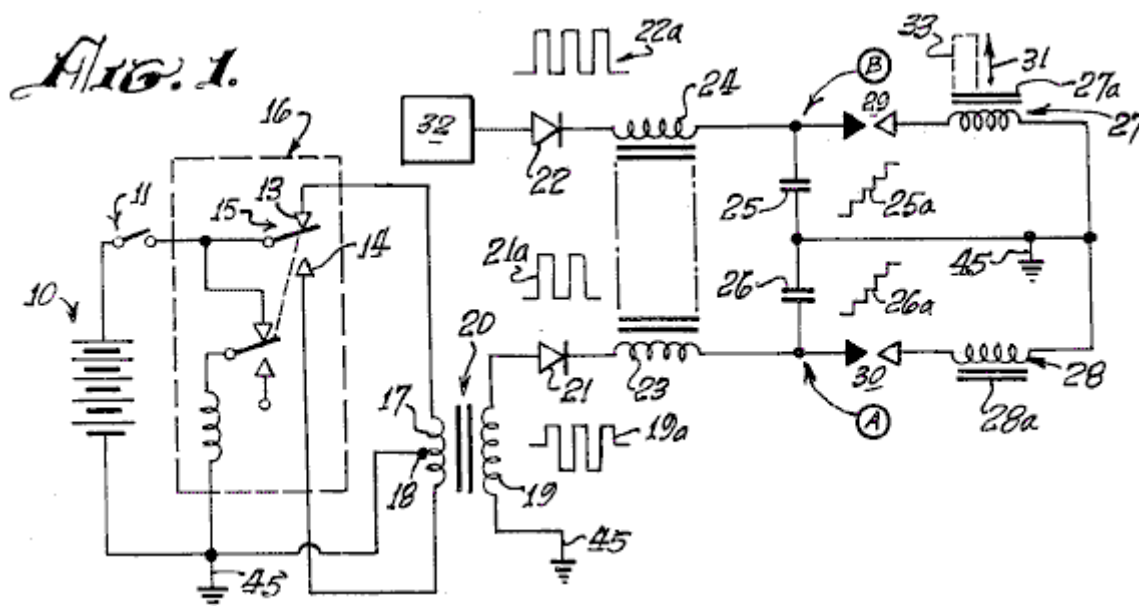

Fig.19 is a developed view, taken at line 19---19 of Fig.11, showing the locations of displaced spark gap elements of the speed changing mechanism of an engine according to the invention.

DESCRIPTION OF THE PREFERRED EMBODIMENT

As mentioned earlier, the basic principle of operation of the engine of the invention, is the discharge of a capacitor across a spark gap and through an inductor. When a pair of inductors is used, and the respective magnetic cores thereof are arranged opposite one another and arranged in opposing magnetic polarity, the discharge through them causes the cores to repel each other with considerable force.



Referring to the electrical schematic diagram of **Fig.1**, a battery **10** energises a pulse-producing vibrator mechanism **16**, which may be of the magnetic type, incorporating an armature **15** moving between contacts **13** and **14**, or of the transistor type (not shown) with which a high frequency bipolar pulsed output is produced in primary **17** of transformer **20**. The pulse amplitude is stepped up in secondary **19** of transformer **20**. Wave form **19a** represents the bi-directional or bi-polar pulsed output. A diode rectifier **21** produces a unidirectional pulse train, as indicated at **21a**, to charge capacitor **26**. Successive unidirectional pulses of wave **21a** charge capacitor **26** to high level, as indicated at **26a**, until the voltage at point **A** rises high enough to cause a spark across the spark gap **30**. Capacitor **26** discharges via the spark gap, through the electromagnet coil **28**. A current pulse is produced which magnetises core **28a**. Simultaneously, another substantially identical charging system **32** produces a discharge through inductor **27** across spark gap **29**, to magnetise core **27a**. Cores **27a** and **28a** are wound with coils **27** and **28** respectively, so that their magnetic polarities are the same. As the cores **27a** and **28a** confront one another, they tend to fly apart when the discharge occurs through coils **27** and **28** because of repulsion of identical magnetic poles, as indicated by arrow **31**. If core **28a** is fixed or stationary, and core **27a** is moveable, then core **27a** may have tools **33** attached to it to perform work when the capacitor discharges.

Referring to **Fig.1** and **Fig.2**, a d-c electrical source or battery **10**, energises pulsators **36** (including at least two vibrators **16** as previously described) when switch **11** between the battery **10** and pulsator **36** is closed, to apply

relatively high frequency pulses to the primaries of transformers 20. The secondaries of transformers 20 are step-up windings which apply bipolar pulses, such as pulses 19a (Fig.1) to the diodes in converter 38. The rectified unidirectional pulsating output of each of the diodes in converter 38 is passed through delay coils 23 and 24, thus forming a harness 37, wound about the case of the engine, as herein after described, which is believed to provide a static floating flux field. The outputs from delay lines 37, drive respective capacitors in banks 39, to charge the capacitors therein, to a relatively high charge potential. A programmer and rotor and stator magnet control array 40, 41, 42, is formed by spark gaps positioned, as hereinafter described, so that at predetermined positions of the rotor during rotation of the engine, as hereinafter described, selected capacitors of the capacitor banks 39 will discharge across the spark gaps through the rotor and stator electromagnets 43 and 44. The converters 38, programmer 40, and controls 41 and 42, form a series circuit path across the secondaries of transformers 20 to the ground, or point of reference potential, 45. The capacitor banks 39 are discharged across the spark gaps of programmer 40 (the rotor and stator magnet controls 41 and 42). The discharge occurs through the coils of stator and rotor electromagnets 43 and 44 to ground 45. Stator and rotor electromagnets are similar to those shown at 27, 27a, 28 and 28a in Fig.1.

The discharge through the coils of stator and rotor electromagnets 43 and 44 is accompanied by a discharge overshoot or return pulse, which is applied to a secondary battery 10a to store this excess energy. The overshoot pulse returns to battery 10a because, after discharge, the only path open to it is that to the battery 10a, since the gaps in 40, 41 and 42 have broken down, because the capacitors in banks 39 are discharged and have not yet recovered the high voltage charge from the high frequency pulsers 36 and the converter rectifier units 38.

In the event of a misfire in the programmer control circuits 40, 41 and 42, the capacitors are discharged through a rotor safety discharge circuit 46 and returned to batteries 10-10a, adding to their capacity. The circuit 46 is connected between the capacitor banks 39 and batteries 10, 10a.

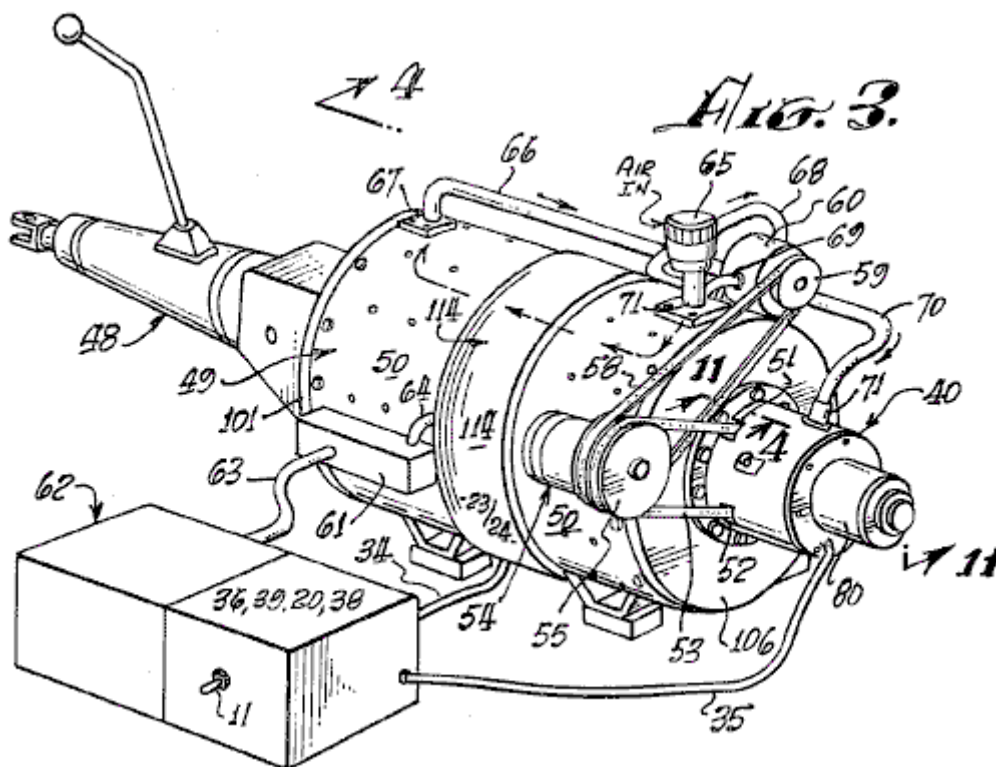

Referring to Fig.3, a motor or engine 49 according to the present invention is shown connected with an automotive transmission 48. The transmission 48, represents one of many forms of loads to which the engine may be applied. A motor housing 50, encases the operating mechanism hereinafter described. The programmer 40 is axially mounted at one end of the housing. Through apertures 51 and 52, a belt 53 couples to a pulley 57 (not shown in this view) and to an alternator 54 attached to housing 50. A pulley 55 on the alternator, has two grooves, one for belt 53 to the drive pulley 58 on the shaft (not shown) of the engine 49, and the other for a belt 58 coupled to a pulley 59 on a pump 60 attached to housing 50. A terminal box 61 on the housing, interconnects between the battery assembly 62 and motor 49 via cables 63 and 64.

An intake 65 for air, is coupled to pump 60 via piping 68 and 69 and from pump 60 via tubing or piping 66 and 70 to the interior of housing 50 via coupling flanges 67 and 71. The air flow tends to cool the engine and the air may preferably be maintained at a constant temperature and humidity so that a constant spark gap discharge condition is maintained. A clutch mechanism 80 is provided on programmer 40.

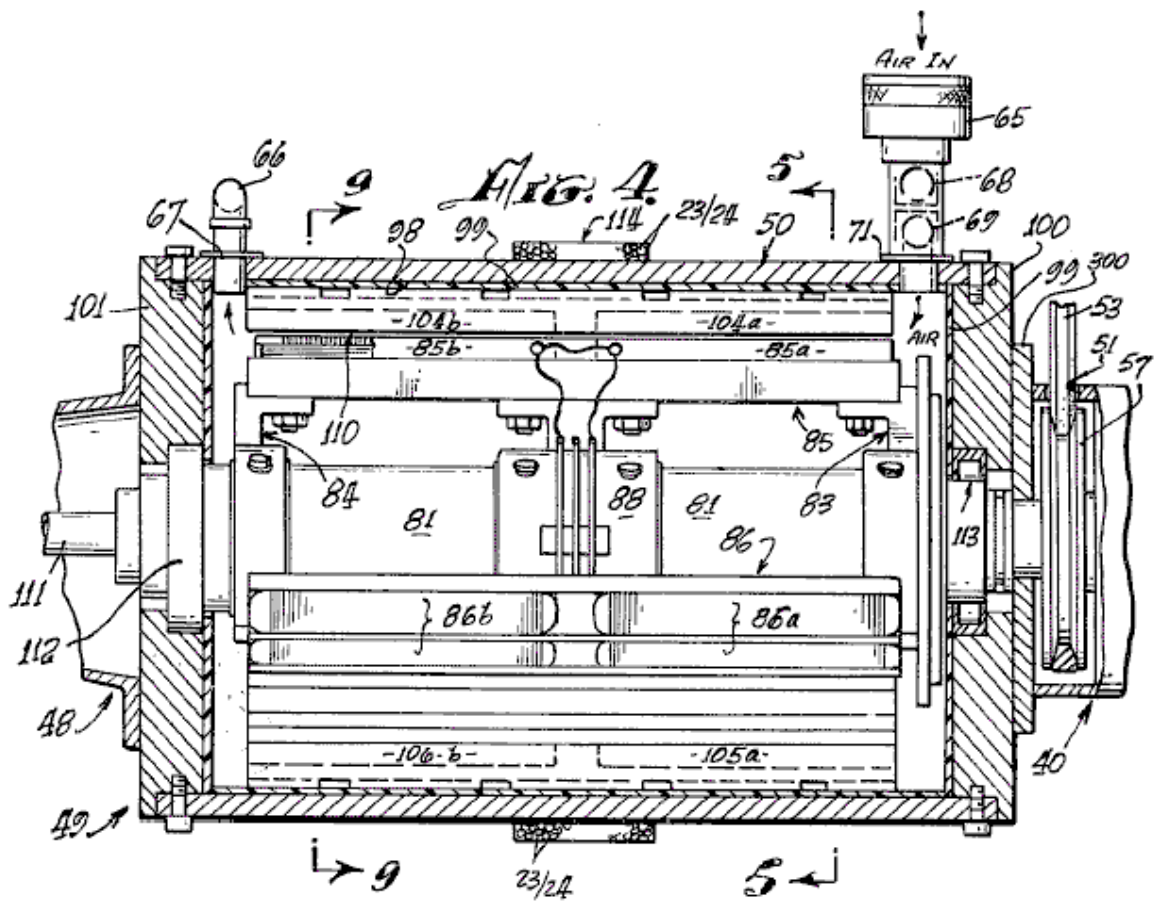

Referring to Fig.4, Fig.5 and Fig.9, rotor 81 has spider assemblies 83 and 84 with three electromagnet coil assembly sets mounted thereon, two of which are shown in Fig.4, on 85, at 85a and 85b and on 86 at 86a and 86b. One of the third electromagnet coil assemblies, designated 87a, is shown in Fig.5, viewed from the shaft end. As more clearly shown in the perspective view of Fig.8, a third spider assembly 88 provides added rigidity and a central support for the rotor mechanism on shaft 81.

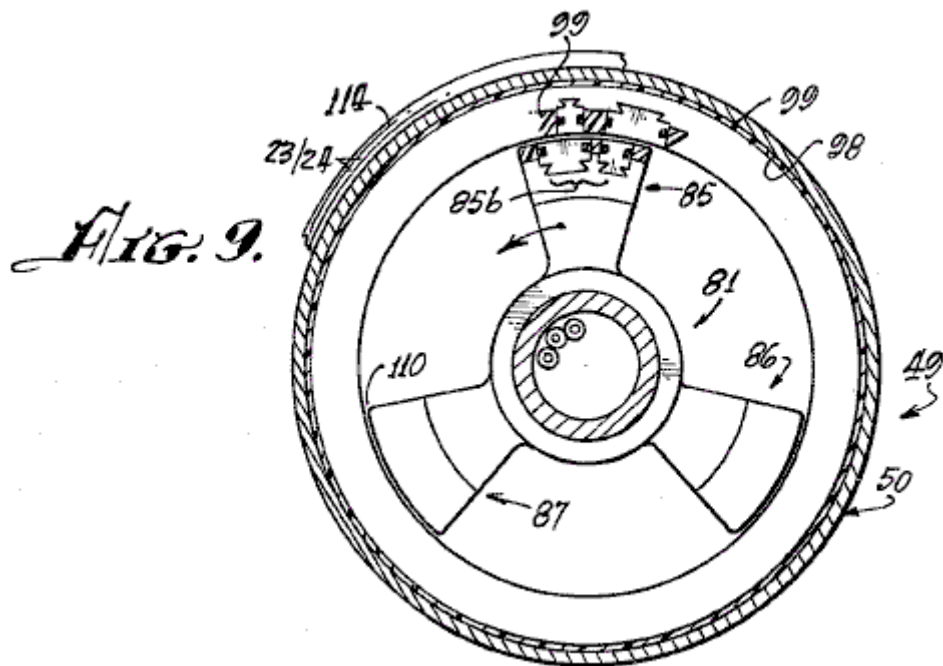

The electromagnet sets 85a, 85b, 86a, 86b, 87a and 87b, disposed on rotor 81 and spiders 83, 84 and 88, each comprise pairs of front units 85a, 86a and 87a and pairs of rear units 85b, 86b and 87b. Each pair consists of a major electromagnet and a minor electromagnet, as hereinafter described, which are imbedded in an insulating

material **90**, which insulates the electromagnet coil assemblies from one another and secures the electromagnets rigidly in place on the spider/rotor cage **81, 83, 84** and **88**.

The interior wall **98**, of housing **50**, is coated with an electrically insulating material **99** in which are imbedded electromagnet coils, as hereinafter described, and the interiors of end plates **100** and **101** of the housing **50**. On the insulating surface **98** of housing **50** is mounted a series of stator electromagnet pairs **104a**, identical with electromagnet pairs **85a, 86a, 87a**, etc. Electromagnet pairs such as **104a** or **105a** are disposed every **40** degrees about the interior of housing **50** to form a stator which co-operates with the rotor **81-88**. An air gap **110** of very close tolerance is defined between the rotor and stator electromagnets and air from pump **65** flows through this gap.

As shown in **Fig.8**, the electromagnet assemblies, such as **85** through **87**, of the rotor and magnet assemblies, such as **104a** in the stator, are so embedded in their respective insulating plastic carriers (rotor and stator) that they are smoothly rounded in a concave contour on the rotor to permit smooth and continuous rotation of rotor **81** in stator housing **50**. The air gap **110** is uniform at all positions of any rotor element within the stator assembly, as is clearly shown in **Fig.16**.

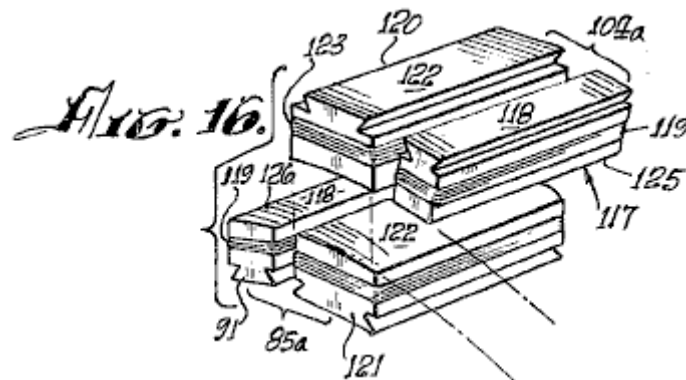

The rotor **81** and spiders **83, 84** and **88** are rigidly mounted on shaft **111** journaled in bearing assemblies **112** and **113** which are of conventional type, for easy rotation of the rotor shaft **111** within housing **50**.

Around the central outer surface of housing **50**, are wound a number of turns of wire **23** and **24** to provide a static flux coil **114** which is a delay line, as previously described. **Figs. 5, 6, 7** and **9** are cross-sectional views of the rotor assembly **81-88**, arranged to show the positioning and alignment of the rotor and stator electromagnet coil assemblies at successive stages of the rotation of the rotor **81-88** through a portion of a cycle of operation thereof. For example, in **Fig.5** the rotor assembly **81-88** is shown so positioned that a minor rotor electromagnet assembly **91** is aligned with a minor stator electromagnet assembly **117**.

As shown in further detail in **Fig.16**, minor electromagnet assembly **117** consists of an iron core **118**, grooved so that a coil of wire **119** may be wound around it. Core **118** is the same in stator electromagnet **117** as it is in rotor electromagnet **91**.

As a position **13.33** degrees to the right of rotor electromagnet **91**, as viewed in **Fig.5** and **Fig.16**, there is a second or major rotor electromagnet **121** which has a winding **123** about its core **122**. The electromagnets **91** and **121** are the pair **85a** of **Fig.4** and **Fig.8**.

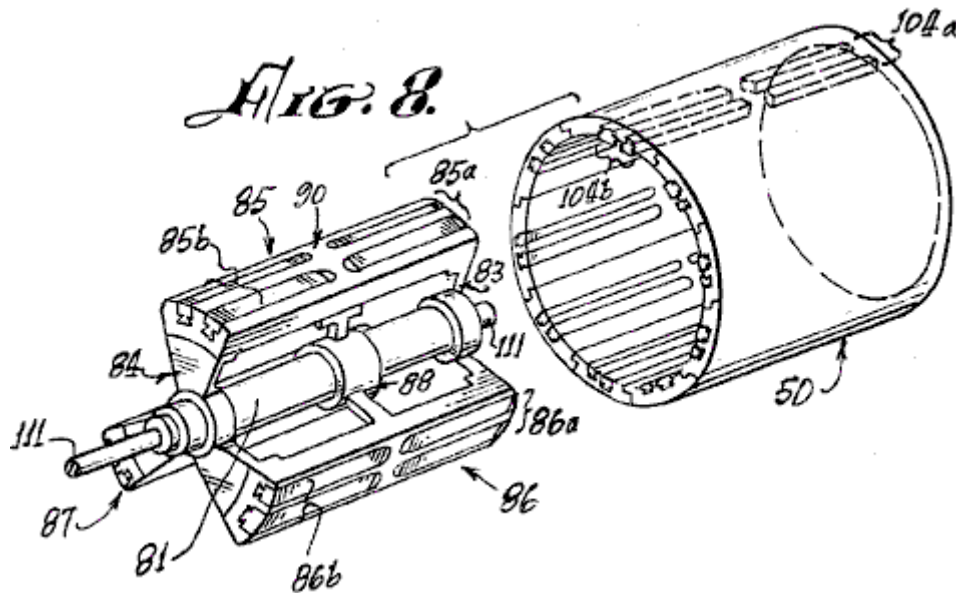

At a position 13.33 degrees to the left of stator electromagnet 117, as viewed in **Fig.5**, there is a second or major stator electromagnet 120 whose core 122 is of the same configuration as core 122 of rotor electromagnet 121. A winding 123 about core 122 of electromagnet 120 is of the same character as winding 123 on electromagnet 121.

Electromagnet assembly pair 85a on the rotor is identical in configuration to that of the electromagnet stator assembly pair 104a except for the position reversal of the elements 117-120 and 91-121 of the respective pairs.

There are none pairs of electromagnets 120-117 (104a) located at 40 degree intervals about the interior of housing 50. The centreline of core 122 of electromagnet 120 is positioned 13.33 degrees to the left of the centreline of the core 118 of electromagnet 117. Three pairs of electromagnets 85a, 86a and 87a are provided on rotor assembly 81-88 as shown in **Fig.5**.

Other combinations are possible, but the number of electromagnets in the rotor should always be in integral fraction of the number of electromagnets in the stator. As shown in **Fig.8**, for the rotor assembly 85a and 85b, there are three of each of the front and back pairs of electromagnetic assemblies. Similarly, as shown in **Fig.4** and **Fig.8**, there are nine front and back pairs of electromagnets in the stator such as 104a and 104b.

In order to best understand the operation of the rotor 81-88 rotating within the stator housing 50 of an engine according to this invention, the positions of rotor electromagnets 91 and stator electromagnets 117 are initially exactly in line at the 13.33 degree peripheral starting position marked on the vertical centreline of **Fig.5**. The winding direction of the coils of these magnets is such that a d-c current through the coils 119 will produce a particular identical magnet polarity on each of the juxtaposed surfaces 125 of magnet 117 and 126 of magnet 91 (**Fig.5**). **Fig.16** and **Fig.6** illustrate the next step in the motion wherein the two major electromagnets, 120 in the stator and 121 in the rotor, are in alignment.

When the d-c discharges from the appropriate capacitors in banks 39 occur simultaneously across spark gaps through the coils 119 of electromagnets 117 and 91, at the instant of their alignment, their cores 118, will repel one another to cause rotor assembly 81-88 to rotate clockwise in the direction indicated by arrow 127. The system does not move in the reverse direction because it has been started in the clockwise direction by the alternator motor 54 shown in **Fig.3**, or by some other starter means. If started counterclockwise, the motor will continue to rotate counterclockwise.

As noted earlier, the discharge of any capacitor occurs over a very short interval via its associated spark gap and the resulting magnetic repulsion action imparts motion to the rotor. The discharge event occurs when electromagnets 117 and 91 are in alignment. As shown in **Fig.5**, rotor electromagnet 91a is aligned with stator electromagnet 117c, and rotor electromagnet 91b is aligned with stator electromagnet 117e at the same time that similar electromagnets 117 and 91 are aligned. A discharge occurs through all six of these electromagnets simultaneously (that is, 117, 91, 117c, 91a, 117e and 91b). A capacitor and a spark gap are required for each coil of each electromagnet. Where, as in the assembly shown in **Fig.8**, front and back pairs are used, both the axial in-line front and back coils are energised simultaneously by the discharge from a single capacitor or from a bank of paralleled capacitors such as 25 and 26 (**Fig.1**). Although **Fig.4** and **Fig.8** indicate the use of front and back electromagnets, it should be evident that only a single electromagnet in any stator position and a corresponding single electromagnet in the rotor position, may be utilised to accomplish the repulsion action of the rotor with respect to the stator. As stated, each electromagnet requires a discharge from a single capacitor or

capacitor bank across a spark gap for it to be energised, and the magnetic polarity of the juxtaposed magnetic core faces must be the same, in order to effect the repulsive action required to produce the rotary motion.

Referring to **Fig.5** and **Fig.6**, the repulsion action causes the rotor to move 13.33 degrees clockwise, while electromagnets **91**, **91a** and **91b** move away from electromagnets **117**, **117c** and **117e** to bring electromagnets **121**, **121a** and **121b** into respective alignment with electromagnets **120a**, **120d** and **120f**. At this time, a capacitor discharge across a spark-gap into their coils **123** occurs, thus moving the rotor. Another 13.33 degrees ahead, as shown in **Fig.7**, major electromagnets **121**, **121a** and **121b** come into alignment with minor electromagnets **117a**, **117d** and **117f**, at which time a discharge occurs to repeat the repulsion action, this action continuing as long as d-c power is applied to the system to charge the capacitor banks.

Fig.18 further illustrates the sequencing of the capacitor discharges across appropriate spark gap terminal pairs. Nine single stator coils and three single rotor coils are shown with their respective interconnections with the spark gaps and capacitors with which they are associated for discharge. When the appropriate spark gap terminals are aligned, at the points in the positioning of the rotor assembly for most effective repulsion action of juxtaposed electromagnet cores, the discharge of the appropriate charged capacitors across the associated spark gap occurs through the respective coils. The capacitors are discharged in sets of three, through sets of three coils at each discharge position, as the rotor moves through the rotor positions. In **Fig.18**, the rotor electromagnets are positioned linearly, rather than on a circular base, to show the electrical action of an electric engine according to the invention. These motor electromagnets **201**, **202** and **203** are aligned with stator electromagnets **213**, **214** and **215** at 0 degrees, 120 degrees and 240 degrees respectively. The stator electromagnets are correspondingly shown in a linear schematic as if rolled out of the stator assembly and laid side by side. For clarity of description, the capacitors associated with the rotor operation **207**, **208**, **209** and **246**, **247**, **248**, **249**, **282** and **283**, are arranged in vertical alignment with the respective positions of the rotor coils **201**, **202** and **203** as they move from left to right, this corresponding to clockwise rotation of the rotor. The stator coils **213**, **214**, **215**, **260**, **261**, **262**, **263**, **264**, **265**, **266**, etc. and capacitor combinations are arranged side by side, again to facilitate description.

An insulative disc **236** (shown in **Fig.17** as a disc but opened out linearly in **Fig.18**) has mounted thereon, three gap terminal blocks **222**, **225** and **228**. Each block is rectangularly U-shaped, and each interconnects two terminals with the base of the U. Block **222** has terminals **222a** and **222b**. Block **225** has terminals **225a** and **225b**. Block **228** has terminals **228c** and **228d**. When insulative disc **230** is part of the rotor as indicated by mechanical linkage **290**, it can be seen that terminal U **222** creates a pair of gaps with gap terminals **223** and **224** respectively. Thus, when the voltage on capacitor **216** from charging unit **219**, is of a value which will arc over the air spaces between **222a** and **223**, and between **222b** and **224**, the capacitor **216** will discharge through the coil of electromagnet **213** to ground. Similarly, gap terminal U **225** forms a dual spark gap with gap terminals **226** and **227** to result in arc-over when the voltage on capacitor **217**, charged by charging circuit **220**, discharges into the coil of electromagnet **214**. Also, U-gap terminal **228** with terminals **228c** and **228d**, creates a spark gap with terminals **229** and **230** to discharge capacitor **218**, charged by charging circuit **221**, into coil **215**. At the same time, rotor coils, **201**, **202** and **203** across gaps **201a - 204**, **202b - 205** and **203c - 206** each receives a discharge from respective capacitors **207**, **208** and **209**.

When the electromagnet coils **213**, **214** and **215** and **201**, **202** and **203** are energised, the repulsion action causes the rotor assembly to move to position 2 where a new simultaneous group of discharges occurs into rotor coils **201**, **202** and **203** from capacitors **246**, **248** and **282** across gaps **201a - 240**, **202b - 242** and **203c - 244**. Simultaneously, because gap-U-elements **222**, **225** and **228** have also moved to position 2 with the rotor assembly, capacitor **261** is discharged through electromagnet coil **260**, capacitor **265** is discharged through electromagnet coil **264**, and capacitor **269** is discharged through electromagnet coil **268** in alignment with position 2 of the rotor electromagnet coils, thus to cause the rotor electromagnets to move to position 3 where the discharge pattern is repeated now with capacitors **247**, **249** and **283** discharging through the rotor electromagnet coils **201**, **202** and **203**, and the capacitors **263**, **267** and **281** discharging respectively through stator electromagnet coils **262**, **266** and **280**.

After each discharge, the charging circuits **219 - 221** and **272 - 277** for the stator capacitors, and **210 - 212** and **284 - 289** for the rotor capacitors, are operated continuously from a battery source as described earlier with reference to **Fig.1**, to constantly recharge the capacitors to which each is connected. Those versed in the art will appreciate that, as each capacitor discharges across an associated spark gap, the resulting drop in potential across the gap renders the gap an open circuit until such time as the capacitor can recharge to the arc-over level for the gap. This recharge occurs before a rotor element arrives at the next position in the rotation.

The mechanical schematic diagram of **Fig.17**, further clarifies the operation of the spark-gap discharge programming system. A forward disc **236** of an electrically insulative material, has thereon the set of U-shaped gap terminal connectors previously described. These are positioned at 0 degrees, 120 degrees and 240 degrees respectively. In **Fig.17**, schematic representations of the position of the coil and capacitor arrangements at the

start of a cycle are shown to correspond to the above description with reference to **Fig.18**. Accordingly, the coil and capacitor combinations **213/216**, **214/217** and **215/218** are shown connected with their gap terminals, respectively, **223/224**, **226/227** and **229/230**. On the rotor coil and capacitor connection, three separate discs **291**, **292** and **293** are shown, each with a single gap terminal. The discs **291 - 293** are rotated so as to position their respective gap terminals 201a, 201b and 201c, at 120 degree increments, with the 0 degrees position corresponding to the 0 degrees position of U-gap terminal **222** on disc **230**.

Representative gap terminals are shown about the peripheries of discs **230**, **291 - 293** to indicate clearly how, as the discs turn in unison, the gap alignments correspond so that three rotor coils always line up with three stator coils at 120 degree intervals about the rotary path, producing an alignment every 40 degrees, there being nine stator coils. Thus, there are three simultaneous discharges into stator coils and three into rotor coils at each 40 degree position. Nine positions displaced 40 degrees apart provide a total of 27 discharge points for capacitors into the rotor coils and 27 discharge points for capacitors into the stator coils in one revolution of the rotor.

It will be understood that, as illustrated in **Fig.17** and **Fig.18**, nine individual electromagnet coils are shown in the stator and three in the rotor, in order to show in its simplest form, how the three rotor electromagnets are stepped forward from alignment with three of the stator electromagnets, when the appropriate spark gaps are in alignment, to effect the discharge of capacitors through juxtaposed pairs of rotor/stator electromagnets. The repulsion moves the rotor electromagnet from the stator electromagnet to the next alignment position 40 degrees further on. In the interval, until another rotor electromagnet, 120 degrees removed, is aligned with the stator electromagnet which had just been pulsed, the associated capacitor is recharged. Thus, the rotor moves from one position to the next, with capacitor discharges occurring each 40 degrees of rotation, a total of nine per revolution. It should be obvious that, with other rotor/stator combinations, the number of electromagnet coincidences and spark-gap discharges will vary. For example, with the coil pairs shown in **Figs 4 through 8**, a total of 27 discharges will occur. Although there are 18 stator electromagnets and 3 rotor electromagnets, the discharge pattern is determined by the specific spark gap arrangement.

The rotor/stator configuration of **Fig.5** and **Fig.8**, involving the major and minor pairs of electromagnets, such as **85a** and **104a** (the terms "minor" and "major" referring to the difference in size of the elements), include nine pairs of electromagnets in the stator, such as **104a**, with three electromagnet pairs of the rotor, such as **85a**. Because of the 13.33 degree separation between the major and minor electromagnets in the rotor pair **85a**, with the same separation of minor and major electromagnets of the stator pair **104a**, the sequence of rotation and discharge described above, with respect to the illustrative example of **Fig.5**, involves the following:

1. A minor element **117** of stator pair **104a** is aligned with the minor element **91** of rotor pair **85a**. On the discharge, this moves the rotor ahead 13.33 degrees.
2. the major rotor element **122** of the pair **85a**, now is aligned with the major stator element **120b** of the next stator electromagnet pair, in the stator array as shown in **Fig.6**. On the discharge, the rotor moves ahead 13.33 degrees.
3. This brings the minor rotor electromagnet **91** into alignment with the major stator electromagnet **120b** of pair **104d**, and the major electromagnet **122** (just discharged) of pair **85a** into alignment with minor electromagnet **117b** of pair **104d**, and the rotor spark gap elements into alignment with a different position of gap elements connected with capacitors not discharged in the previous position of the rotor. It should be remembered at this point that it is the positioning of a rotatable spark gap array, similar to that illustrated in **Fig.17** and **Fig.18**, which controls the time of discharge of capacitors connected to these gap terminals. Therefore, any electromagnet can be energised twice, successively, from separate capacitors as the rotor brings appropriate gap terminals into alignment with the coil terminals of a particular electromagnet.

Thus, although major electromagnet **120b** of pair **104d** has just been energised as described above, it can now be energised again along with minor rotor electromagnet **91** in step 3, because the rotor moved to a new set of terminals of the spark gap arrays connected to capacitors which have not yet been discharged. These capacitors now discharge through rotor electromagnet **91** and stator electromagnet **120b**, causing the rotor to move ahead another 13.33 degrees, thus again aligning two minor electromagnets again, these being **117b** of stator pair **104d** and **91** of rotor pair **85a**. The rotor has now moved 40 degrees since step 1 above. The sequence is now repeated indefinitely. It is to be noted that at each 13.33 degree step, the discharges drive the rotor another 13.33 degrees. There are 27 steps per revolution with nine stator coil pairs. The discharge sequence is not uniform, as is shown in Table 1. In the stator, three major electromagnets 120 degrees apart are energised twice in sequence, followed by a hiatus of one step while three minor electromagnets of the stator, 120 degrees apart, are energised during the hiatus. In the rotor the major electromagnets are energised during a hiatus step following two minor electromagnet energisation steps. A total of 27 energisations are this accomplished in the nine pairs of coils of the stator.

In Table 1, the leftmost column shows the location of each rotor arm **85**, **86** and **87** at an arbitrarily selected step No. 1 position. For example, in step 1, rotor arm **85** has a minor stator and minor rotor electromagnet in alignment for capacitors to discharge through them simultaneously at the 13.33 degree position.

TABLE I

CAPACITOR DISCHARGE SEQUENCE FOR ONE REVOLUTION OF ROTOR IN SYSTEM OF FIGS. 5 AND 8								
Step No.	Rotor Arm			Rotor Electro-magnet		Stator Electro-magnet		
	87	85	86	Angle	Minor	Major	Minor	Major
10	1	19	13	1/3°	x		x	
11	2	20	26	2/3°		x		x
12	3	21	40°		x			x
13	4	22	53	1/3°	x		x	
14	5	23	66	2/3°		x		x
15	6	24	80°		x			x
16	7	25	93	1/3°	x		x	
17	8	26	106	2/3°		x		x
18	9	27	120°		x			x
19	10	1	133	1/3°	x		x	
20	11	2	146	2/3°		x		x
21	12	3	160°		x			x
22	13	4	173	1/3°	x		x	
23	14	5	186	2/3°		x		x
24	15	6	200°		x			x
25	16	7	213	1/3°	x		x	
26	17	8	226	2/3°		x		x
27	18	9	240°		x			x
1	19	10	253	1/3°	x		x	
2	20	11	266	2/3°		x		x
3	21	12	280°		x			x
4	22	13	293	1/3°	x		x	
5	23	14	306	2/3°		x		x
6	24	15	320°		x			x
7	25	16	333	1/3°	x		x	
8	26	17	346	2/3°		x		x
9	27	18	360°		x			x

Similarly, in step 1, rotor arm **86** is at the 133.33 degree position which has two minor electromagnets in alignment, ready for discharge. Simultaneously, rotor arm 87 is at the 253.33 degree position with two minor electromagnets aligned for capacitor discharge. The other steps of the sequence are apparent from Table 1, for each position of the three rotor arms at any step and the juxtapositions of respective stator and rotor electromagnet elements at that position.

In the simplified motor arrangement shown in schematic form in **Fig.18**, with single electromagnet configuration, the alignment is uniform and the discharge sequences follow sequentially.

As mentioned before, a change in speed is effected by displacing the stator spark gap terminals on the rotor (shown at **236** in **Fig.17** and **Fig.18**) either counterclockwise or clockwise 6.66 degrees so that the discharge position of the stator electromagnets is displaced. Referring to **Figs. 11 to 15**, the simultaneous discharge of selected capacitors into the displaced electromagnets results in a deceleration if the rotor electromagnet is approaching the stator electromagnet at the time of discharge, or an acceleration if the rotor electromagnet is leaving the stator electromagnet at the time of the discharge pulse. In each event, there is a repulsive reaction between the stator and rotor electromagnets which effects this change in speed.

Referring to **Fig.11**, clutch mechanism **304** about shaft **111** is operated electromagnetically in conventional manner, to displace the spark-gap mechanism **236** which is operated normally in appropriate matching alignment with the rotor spark-gap discs **291, 292** and **293**. Clutch **304** has a fixed drive element **311**, containing an electromagnetic drive coil (not shown) and a motor element **310** which, when the electromagnetic drive coil is energised, can be operated by a direct current. The operation of motor element 310, brings into operation, spark gap elements **224r, 223r** or **223f, 224f** of the system shown in **Figs. 4, 5 and 8**, as illustrated in **Fig.19**.

The fixed stator coil spark gap terminal pairs **223, 224** and **266, 267** are arrayed about a cylindrical frame **322** which is fabricated in insulative material. In the illustrative example of **Fig.17** and **Fig.18**, there are nine such spark gap terminal pairs positioned around the periphery of the cylinder frame **324**. In the engine of **Figs. 4 to 8**, a total of 27 such spark gap pairs are involved. In addition, although not shown in the drawing, there are also pairs of terminals, such as **223r** or **223f, 224r** or **224f** and **226r** or **226f, 267r** or **267f**, displaced 6.66 degrees on either side of the pairs **223, 224** or **266, 267** and all other pairs in the spark gap array, the letters "r" and "f" denoting "retard" or "faster". The latter displaced pairs are used in controlling the speed of the engine rotor. The displaced pairs not shown are involved in the operation of the clutch **304**, the speed-changing control element.

Clutch **304** is associated with shaft **111** in that the movable element **310** draws clutch disc element **316** on shaft **111**, away from clutch disc element **322** when energised by a voltage of appropriate polarity applied to its motor electromagnet **311**. Such clutch drives are well known in the art.

The clutch mechanism **304** of **Fig.11** and **Fig.19**, when not energised, is in the configuration shown in **Fig.11**. The energised configuration of clutch **304** is not specifically illustrated. Upon energisation, spark-gap element **222** on disc **236** is displaced rightward, as viewed in **Fig.11**, by broken lines **236X**, into alignment with the positions of fixed spark-gap terminals **223f**, **224f** and **267r**, **266r**. When the disc is in position **236X**, the flattened edge **332** of pin **330** in disc **325** rides on surface **350** of disc **322**. Normally, the flattened edges **351** of pins **330** are engaged against the flat edge **352** in recess **331** of disc **322**. The displacement of disc **322** on shaft **111** is effected by the action of clutch **304** against spring **314** (**Fig.11**). An electric switch (not shown) of clutch mechanism **304** energises it from a d-c power source, and has two positions, one for deceleration and one for acceleration. In either position, clutch **304** is engaged to pull clutch disc **322** from clutch disc **325**, momentarily. For the decelerate or the accelerate position, the displaced alignment of spark gap elements **222** is with the **224f**, **223f** and the **224r**, **223r** spark-gap terminal elements. However, only the **224f**, **223f** spark-gap elements are switched into operation with appropriate capacitors for the accelerate position, while in the decelerate position, only the **223r** and **224r** spark-gap elements are switched into the circuit with their associated capacitors.

Of course, when insulative disc **236** is displaced by clutch **304**, its gap terminals **222**, **225** and **228** (**Fig.14** and **Fig.18**) are all displaced into the alignment position of **236X** so as to engage the "r" and "f" lines of fixed spark gap elements. Although the accelerate and decelerate positions of disc **236** are the same, it is the switching into operation of the **223**, **224** or **266**, **267** exemplary "r" or "f" pairs of terminals which determines whether the rotor will speed up or slow down.

The momentary displacement of clutch disc **322** from clutch disc **325** results in rotation of disc **325** about disc **322** through an angle of 120 degrees. The detent ball and spring mechanism **320**, **321** in disc **325**, positions itself between one detent dimple **328** and a succeeding one **328** at a position 120 degrees away on disc **325**.

As stated, flat **332** of pin **330** rides on surface **350** of disc **322**, and pin **330** leaves the pin-holding groove **331/352** along ramp **333** in disc **322** during the momentary lifting of disc **322** by clutch **304**. Pin **330** falls back into the next groove **331** at a point 120 degrees further on about disc **322**. Pin **330** falls into place in groove **331** on ramp **334**. Pins **330** are rotatable in their sockets **353**, so that for either clockwise or counterclockwise rotation, the flat **351** will engage the flat **352** by the particular ramp it encounters.

The deceleration or acceleration due to the action of clutch **304** thus occurs within a 120 degree interval of rotation of disc **325**. During this interval, disc **322** may only move a fraction of this arc.

There has been described earlier, an electromotive engine system wherein at least one electromagnet is in a fixed position and a second electromagnet of similar configuration is juxtaposed with it in a magnetic polarity relationship such that, when the cores of the electromagnets are energised, the juxtaposed core faces repel each other. One core being fixed, and the second core being free to move, any attachments to the second electromagnet core will move with it. Hence, if a plurality of fixed cores are positioned about a circular confining housing, and, within the housing, cores on a shaft are free to move, the shaft is urged rotationally each time the juxtaposed fixed and rotatable cores are in alignment and energised. Both the fixed and the movable cores are connected to spark gap terminal elements and the associated other terminal elements of the spark gaps are connected to capacitors which are charged to high voltage from pulsed unipolar signal generators. These capacitors are discharged through the electromagnets across the spark gaps. By switching selected groups of capacitors into selected pairs of spark gap elements for discharge through the electromagnets, the rotor of the circular array systems is accelerated and decelerated.

By confining a fixed electromagnet array in a linear configuration, with a linearly movable electromagnet to which a working tool is attached, exciting the juxtaposed pairs of electromagnets by capacitor discharge, results in the generation of linear force for such tools as punch presses, or for discharging projectiles with considerable energy.

CLAIMS:

1. An electric engine comprising:

A housing;

An array of electromagnets uniformly spaced in said housing to form a stator;

A rotor cage on a shaft journaled in and rotatable within said stator, said rotor cage having thereon a spaced array of electromagnets similar to said stator electromagnets and in number, comprising an integral fraction of the number of electromagnets in said stator array;

Each of the electromagnets of said stator and of said rotor, having a core which can be magnetised and of a particular configuration and each being wound with a coil such that a pulses of unidirectional electric current through said coil, magnetises the respective core thereof to a particular magnetic polarity, and the faces of rotor cores juxtaposing selected stator cores are magnetised to the same polarity, the juxtaposed cores thereby tending to repel one another, one lead of each of the stator and rotor coils being connected to a common terminal, the other lead of each of said coils being connected to a gap terminal, the gap terminals of said rotor coils being on the rotor and equal in number to the number of coils thereon and matching the positions of said rotor electromagnets thereon, the gap terminals of said stator being equal in number to the number of coils on the stator and disposed uniformly about said stator to match the positions of said stator electromagnets within said housing;

A first array of capacitors, each having a terminal in common with the common coil terminal of said stator electromagnets, and each capacitor having its other terminal connected to a gap terminal arrayed adjacent the gap terminal of an electromagnet associated therewith;

A second array of capacitors, each having a terminal in common with said common terminal of said rotor electromagnet coils but equal in number to the number of capacitors in said stator array, the other terminals of said capacitors in said second array being connected to gap terminals arrayed about said housing so as to be in axial alignment with said stator gap terminal positions and being alignable with said rotor gap terminals as said rotor is rotated in said housing and respective gap terminals of said rotor coils pass each second array capacitor gap terminals at a predetermined gap distance;

Gap coupling terminals on said rotor equal in number to the number of rotor electromagnet coils and positioned to match the rotor electromagnet positions on said rotor, the gap coupling terminals being rotatable with said rotor so as to pass said adjacent stator coil and associated stator capacitor gap terminal at a predetermined distance therefrom;

A plurality of capacitor charging circuits connected respectively across each of said capacitors in both said first and said second arrays of capacitors for charging each of said capacitors to a predetermined high d-c potential;

A first source of unidirectional electric potential connected to each of said capacitor charging circuits for energising said charging circuits; and

A second unidirectional electric potential source connected to said electromagnets of said rotor and said stator of such polarity as to receive a charge from the inverse inductive discharge of the electromagnet coils as their fields collapse following the discharge of each capacitor through a rotor or stator electromagnet coil,

Whereby, whenever a rotor electromagnet is aligned opposite a stator electromagnet, the rotor coil gap terminal of that electromagnet is opposite an associated second capacitor array gap terminal, and a gap coupling terminal of said rotor is aligned opposite the stator electromagnet coil gap terminal and associated first capacitor gap terminal, the capacitors discharge the charge thereon across the gaps through their associated electromagnet coils to magnetise their respective juxtaposed electromagnet cores to cause them to repel one another, thus aligning a succeeding pair of rotor and stator electromagnets for capacitor discharge across their respective gaps, to cause them to repel one another, alignments rotor rotation within the housing continuously bringing successive rotor-stator electromagnets into alignment for discharge of the capacitors through them to produce continuous rotary motion of the rotor on said rotor shaft, so long as energy is applied to said charging circuits to recharge said capacitors after each discharge.

2. In an electric engine having a rotor comprising electromagnetic coil means rotatable within a stator comprising similar electromagnetic coil means, said electromagnetic coil means being polarised for magnetic repulsion;

Capacitor means electrically coupled across successive spark gaps to selected ones of said stator and all of the coils of said rotor;

Charging means connected to said capacitor means for charging said capacitor means to an electrical charge potential sufficient to cause arcing across said spark gaps to result in the discharge of said capacitor means through the electromagnetic coil means repel one another; and

A unidirectional electric power source connected to said charging means to energise said charging means to continue charging said capacitor means following each discharge whereby the rotor of said engine is maintained

in rotation by the successive discharges of said capacitor means across successive spark gaps into said electromagnetic coil means.

3. An electric engine according to claim 2, wherein:

The charging means includes electronic square core oscillators connected to said unidirectional electric power source and includes step-up means and a rectifier to produce a substantial voltage step up from the voltage of said power source.

4. An electric engine according to claim 2, wherein:

The charging means includes a vibrator connected to said power source, and step-up transformer and rectifier means to provide a high voltage for charging said capacitor means.

5. A motive force-producing means comprising:

At least a first electromagnet means including at least one coil wound about a core,

At least a second electromagnet means including at least one coil wound about a core similar to said first core,

The respective cores being positioned adjacent to one another so that the magnetic polarities of the adjacent core surfaces are the same when a unidirectional electric current is passed through the coils,

At least one capacitor means having one terminal thereof connected to one terminal of both of said electromagnet coils,

The other terminal of said capacitor means being connected to one terminal of a spark gap means, the other terminals of the coils of both said first and said second electromagnet means being connected to the other terminal of said spark gap means,

At least one unidirectional pulse charging means connected to said capacitor means to charge said capacitor means to a relatively high potential sufficient to arc across said spark gap means at predetermined spacing of said gap terminals, and

A source of unidirectional potential connected to said charging circuit to energise said charging means,

Whereby upon application of current from said potential source to said charging means the successive pulses generated thereby charge said capacitor means to a voltage level sufficient to arc across said spark gap means to produce a discharge path for said capacitor means through said coils to cause said electromagnet means to repel one another with a substantial force.

6. A motive force-producing means according to claim 5, wherein:

Said first electromagnet means is secured in a relatively stable housing, and said second electromagnet means is connected with and freely movable relative to said stable housing, and has utilisation means connected thereto for performing work therewith when said capacitor means discharges through said coils of said electromagnet means.

7. A motive force-producing means according to claim 6, wherein said utilisation means is a motor rotor coupled with said second electromagnet means and said first electromagnet means is a stator.

8. A motive force-producing means according to claim 6, wherein said utilisation means is a piston attached to said second electromagnet means and is movable therewith to produce hammer-like blows when said capacitor means discharges through said electromagnet means.

9. In an electromotive force-generating system as disclosed, means for accelerating or decelerating the motion of a force-generating system, said means comprising:

At least two juxtaposed electromagnetic core elements, one fixed and one movable, including coils wound around it to provide a repulsion tendency when said cores are energised,

Spark gap terminals connected with said coils,

Capacitor means connected with said spark gap terminals to discharge across said spark gap terminals through said coils when a charge of sufficient voltage level appears across said capacitor means, thus to energise said juxtaposed electromagnets to induce said juxtaposed electromagnet cores to repel one another,

Charging means connected to said capacitors for charging them to said sufficient voltage level, and selective positioning means coupled with said spark gap terminals and with at least said movable electromagnet core to cause selective displacement of said movable core with respect to said fixed core.

10. An electromotive force-generating system according to claim 9, wherein:

Said juxtaposed electromagnetic cores include a plurality of fixed cores and a smaller number of movable cores, said smaller number being an integral fraction of the number of fixed cores, and

Said selective positioning means is an electromagnetic clutch coupled with said smaller number of movable cores for movement therewith, and includes selective displacement means coupled with said spark gap terminals connected with said capacitors in said capacitor means and selected combinations of coils in said plurality of fixed electromagnets.

11. The method of generating motive power comprising the steps of:

a. positioning similar electromagnets in juxtaposed relationship with their respective cores arranged for repulsion when said electromagnets are energised,

b. charging capacitors to a relatively high potential, and

c. discharging said capacitors simultaneously through said electromagnets across spark gaps set to break down at said relatively high potential, thereby to cause said similar electromagnets to repel one another with considerable force.

12. The method of generating motive power defined in claim 11, wherein, in said positioning step at least one of said electromagnets is maintained in a fixed position and another electromagnet is free to move relative to said fixed electromagnet.

13. The method of generating motive power according to claim 11, wherein:

The charging step includes the charging of capacitors to a relatively high potential from a pulsed unipolar source of electrical energy.

14. in an electromagnetic capacitor discharge engine including movable electromagnets and fixed electromagnets, said movable electromagnets being movable into polar alignment with said fixed electromagnets, capacitor means, means for charging said capacitor means, and means for discharging said charged capacitor means through said fixed and movable electromagnets to polarise aligned fixed and movable electromagnets for magnetic repulsion, an acceleration and deceleration control means comprising:

First selective means for momentarily delaying the discharge of the capacitors until the movable electromagnets in said engine have begun to recede from the fixed electromagnets, in order to accelerate the motion of said movable electromagnets by the added impetus of the repulsion, and

Second selective means for momentarily accelerating the discharge of the capacitors to occur at a point in the motion of the movable electromagnets where said movable electromagnets are approaching said fixed electromagnets to decelerate the motion of said movable electromagnets by the tendency to repel the approaching electromagnets by the fixed electromagnets.

15. An electric engine, comprising:

Fixed electromagnets;

Movable electromagnets, movable into alignment with said fixed electromagnets;

Capacitor means;

Means for charging said capacitor means, and

Means for discharging said charged capacitor means through said fixed and movable electromagnets to polarise said aligned fixed and movable electromagnets for magnetic repulsion.

16. An electric engine as recited in claim 15, wherein: said means for discharging said charged capacitor means comprises voltage breakdown switch means.

17. An electric engine as recited in claim 16, wherein:

Said voltage breakdown switch means includes at least one terminal movable with at least one of said movable electromagnets for breaking down when said at least one of said movable electromagnets is in alignment with a said fixed electromagnet.

18. An electric engine as recited in claim 17, wherein:

Said voltage breakdown switch means comprises a spark gap means.

EFFICIENT POWER SUPPLY SUITABLE FOR INDUCTIVE LOADS



Please note that this is a re-worded excerpt from this patent. It describes the circuitry used with Edwin Gray's power tube. Please be aware Edwin wanted at all costs, to conceal any useful technology while getting patents to encourage investors, so please understand that this patent is not intended to tell you how to make a working system of this type.

- Fig.1** is a schematic circuit diagram of the electrical driving system.
- Fig.2** is an elevational sectional view of the electrical conversion element.
- Fig.3** is a plan sectional view taken along line 3--3 of Fig.2.
- Fig.4** is a plan sectional view taken along line 4--4 of Fig.2.
- Fig.5** is a schematic circuit diagram of the alternating-current input circuit.

SUMMARY OF THE INVENTION

The present invention provides a more efficient driving system comprising a source of electrical voltage; a vibrator connected to the low-voltage source for forming a pulsating signal; a transformer connected to the vibrator for receiving the pulsating signal; a high-voltage source, where available, connected to a bridge-type rectifier; or the bridge-type rectifier connected to the high voltage pulse output of the transformer; a capacitor for receiving the voltage pulse output; a conversion element having first and second anodes, electrically conductive means for receiving a charge positioned about the second anode and an output terminal connected to the charge receiving means, the second anode being connected to the capacitor; a commutator connected to the source of electrical voltage and to the first anode; and an inductive load connected to the output terminal whereby a high energy discharge between the first and second anodes is transferred to the charge receiving means and then to the inductive load.

As a sub-combination, the present invention also includes a conversion element comprising a housing; a first low voltage anode mounted to the housing, the first anode adapted to be connected to a voltage source; a second high voltage anode mounted to the housing, the second anode adapted to be connected to a voltage source; electrically conductive means positioned about the second anode and spaced therefrom for receiving a charge, the charge receiving means being mounted to the housing; and an output terminal communicating with the charge receiving means, said terminal adapted to be connected to an inductive load.

The invention also includes a method for providing power to an inductive load comprising the steps of providing a voltage source, pulsating a signal from said source; increasing the voltage of said signal; rectifying said signal; storing and increasing the signal; conducting said signal to a high voltage anode; providing a low voltage to a second anode to form a high energy discharge; electrostatically coupling the discharge to a charge receiving element; conducting the discharge to an inductive load; coupling a second capacitor to the load; and coupling the second capacitor to the source.

It is an aim of the present invention to provide a system for driving an inductive load which system is substantially more efficient than any now existing. Another object of the present invention is to provide a system for driving an inductive load which is reliable, is inexpensive and simply constructed.

The foregoing objects of the present invention together with various other objects, advantages, features and results thereof which will be evident to those skilled in the art in light of this disclosure may be achieved with the exemplary embodiment of the invention described in detail hereinafter and illustrated in the accompanying drawings.

DESCRIPTION OF THE PREFERRED EMBODIMENT

While the present invention is susceptible of various modifications and alternative constructions, an embodiment is shown in the drawings and will herein be described in detail. It should be understood however that it is not the intention to limit the invention to the particular form disclosed; but on the contrary, the invention is to cover all modifications, equivalents and alternative constructions falling within the spirit and scope of the invention as expressed in the appended claims.

There is disclosed herein an electrical driving system which, on theory, will convert low voltage electric energy from a source such as an electric storage battery to a high potential, high current energy pulse that is capable of developing a working force at the inductive output of the device that is more efficient than that which is capable of being developed directly from the energy source. The improvement in efficiency is further enhanced by the capability of the device to return that portion of the initial energy developed, and not used by the inductive load in the production of mechanical energy, to the same or second energy reservoir or source for use elsewhere, or for storage.

This system accomplishes the results stated above by harnessing the "electrostatic" or "impulse" energy created by a high-intensity spark generated within a specially constructed electrical conversion switching element tube. This element utilises a low-voltage anode, a high-voltage anode, and one or more "electrostatic" or charge receiving grids. These grids are of a physical size, and appropriately positioned, as to be compatible with the size of the tube, and therefore, directly related to the amount of energy to be anticipated when the device is operating.

The low-voltage anode may incorporate a resistive device to aid in controlling the amount of current drawn from the energy source. This low-voltage anode is connected to the energy source through a mechanical commutator or a solid-state pulser that controls the timing and duration of the energy spark within the element. The high-voltage anode is connected to a high-voltage potential developed by the associated circuits. An energy discharge occurs within the element when the external control circuits permit. This short duration, high-voltage, high-current energy pulse is captured by the "electrostatic" grids within the tube, stored momentarily, then transferred to the inductive output load.

The increase in efficiency anticipated in converting the electrical energy to mechanical energy within the inductive load is attributed to the utilisation of the most optimum timing in introducing the electrical energy to the load device, for the optimum period of time.

Further enhancement of energy conservation is accomplished by capturing a significant portion of the energy generated by the inductive load when the useful energy field is collapsing. This energy is normally dissipated in load losses that are contrary to the desired energy utilisation, and have heretofore been accepted because no suitable means had been developed to harness this energy and restore it to a suitable energy storage device.

The present invention is concerned with two concepts or characteristics. The first of these characteristics is observed with the introduction of an energising current through the inductor. The inductor creates a contrary force (counter-electromotive force or CEMP) that opposes the energy introduced into the inductor. This CEMP increases throughout the time the introduced energy is increasing.

In normal applications of an alternating-current to an inductive load for mechanical applications, the useful work of the inductor is accomplished prior to terminating the application of energy. The excess energy applied is thereby wasted.

Previous attempts to provide energy inputs to an inductor of time durations limited to that period when the optimum transfer of inductive energy to mechanical energy is occurring, have been limited by the ability of any such device to handle the high current required to optimise the energy transfer.

The second characteristic is observed when the energising current is removed from the inductor, As the current is decreased, the inductor generates an EMF that opposes the removal of current or, in other words, produces an energy source at the output of the inductor that simulates the original energy source, reduced by the actual energy removed from the circuit by the mechanical load. This "regenerated", or excess, energy has previously been lost due to a failure to provide a storage capability for this energy.

In this invention, a high-voltage, high-current, short duration energy pulse is applied to the inductive load by the conversion element. This element makes possible the use of certain of that energy impressed within an arc across a spark-gap, without the resultant deterioration of circuit elements normally associated with high energy electrical arcs.

This invention also provides for capture of a certain portion of the energy induced by the high inductive kick

produced by the abrupt withdrawal of the introduced current. This abrupt withdrawal of current is attendant upon the termination of the stimulating arc. The voltage spike so created is imposed upon a capacitor that couples the attendant current to a secondary energy storage device.

A novel, but not essential, circuit arrangement provides for switching the energy source and the energy storage device. This switching may be so arranged as to actuate automatically at predetermined times. The switching may be at specified periods determined by experimentation with a particular device, or may be actuated by some control device that measures the relative energy content of the two energy reservoirs.

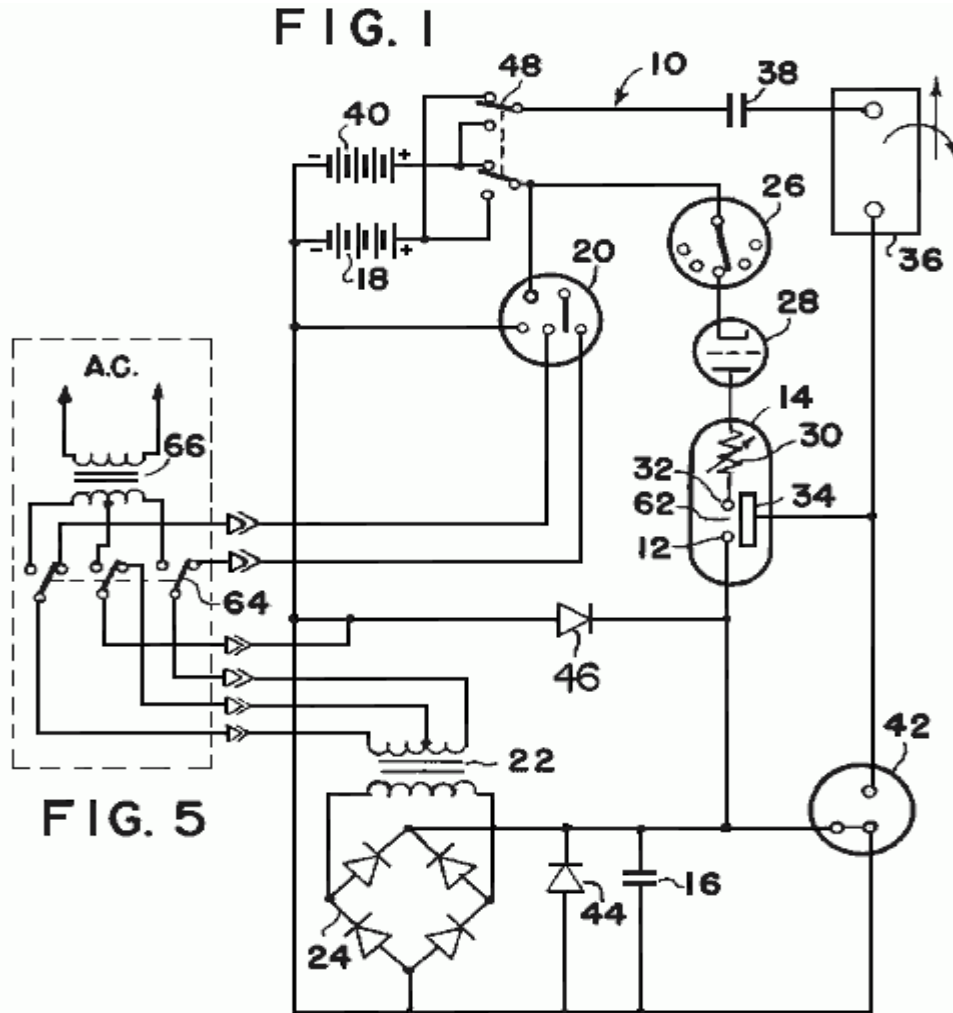

Referring now to **Fig.1**, the system **10** will be described in additional detail. The potential for the high- voltage anode, **12** of the conversion element **14** is developed across the capacitor **16**. This voltage is produced by drawing a low current from a battery source **18** through the vibrator **20**. The effect of the vibrator is to create a pulsating input to the transformer **22**. The turns ratio of the transformer is chosen to optimise the volt- age applied to a bridge-type rectifier **24**. The output of the rectifier is then a series of high-voltage pulses of modest current. When the available source is already of the high voltage, AC type, it may be coupled directly to the bridge-type rectifier.

By repetitious application of these output pulses from the bridge-type rectifier to the capacitor **16**, a high-voltage, high-level charge is built up on the capacitor.

Control of the conversion switching element tube is maintained by a commutator **26**. A series of contacts mounted radially about a shafts or a solid-state switching device sensitive to time or other variable may be used for this control element. A switching element tube type one-way energy path **28** is introduced between the commutator device and the conversion switching element tube to prevent high energy arcing at the commutator current path. When the switching element tube is closed, current from the voltage source **18** is routed through a resistive element **30** and a low voltage anode **32**. This causes a high energy discharge between the anodes within the conversion switching element tube **14**.

The energy content of the high energy pulse is eletrostatically coupled to the conversion grids **34** of the conversion element. This electrostatic charge is applied through an output terminal **60** (**Fig.2**) across the load

inductance **36**, inducing a strong electromagnetic field about the inductive load. The intensity of this electromagnetic field is determined by the high electromotive potential developed upon the electrostatic grids and the very short time duration required to develop the energy pulse.

If the inductive load is coupled magnetically to a mechanical load, a strong initial torque is developed that may be efficiently utilised to produce physical work

Upon cessation of the energy pulse (arc) within the conversion switching element tube the inductive load is decoupled, allowing the electromagnetic field about the inductive load to collapse. The collapse of this energy field induces within the inductive load a counter EMF. This counter EMF creates a high positive potential across a second capacitor which, in turn, is induced into the second energy storage device or battery **40** as a charging current. The amount of charging current available to the battery **40** is dependent upon the initial conditions within the circuit at the time of discharge within the conversion switching element tube and the amount of mechanical energy consumed by the workload.

A spark-gap protection device **42** is included in the circuit to protect the inductive load and the rectifier elements from unduly large discharge currents. Should the potentials within the circuit exceed predetermined values, fixed by the mechanical size and spacing of the elements within the protective device, the excess energy is dissipated (bypassed) by the protective device to the circuit common (electrical ground).

Diodes **44** and **46** bypass the excess overshoot generated when the "Energy Conversion Switching Element Tube" is triggered. A switching element **U** allows either energy storage source to be used as the primary energy source, while the other battery is used as the energy retrieval unit. The switch facilitates interchanging the source and the retrieval unit at optimum intervals to be determined by the utilisation of the conversion switching element tube. This switching may be accomplished manually or automatically, as determined by the choice of switching element from among a large variety readily available for the purpose.

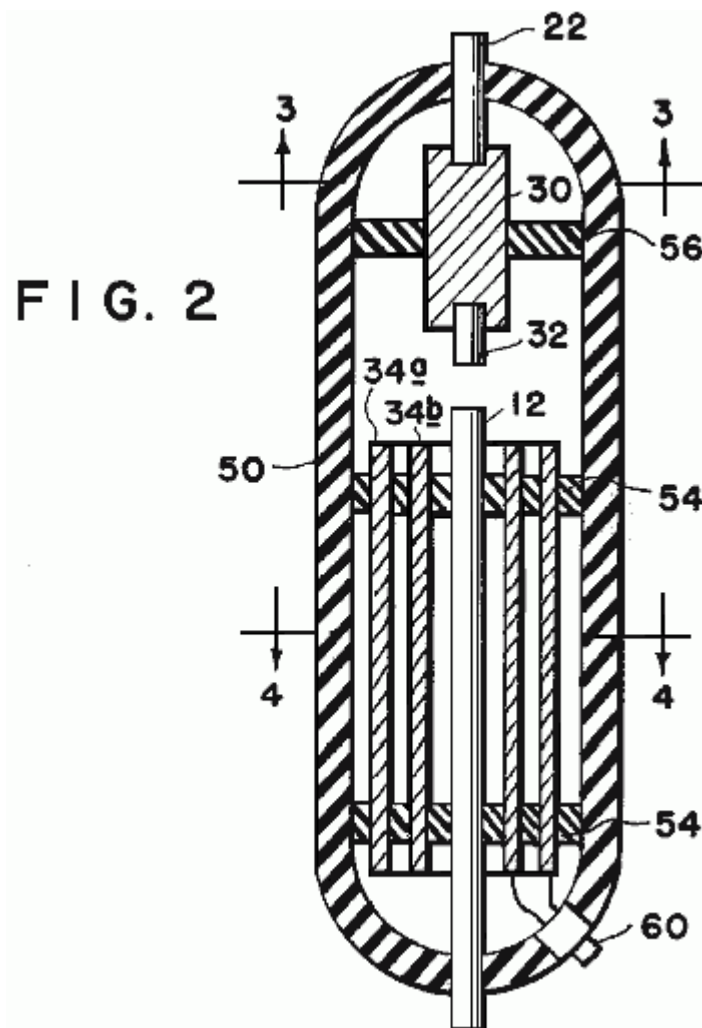

FIG. 3

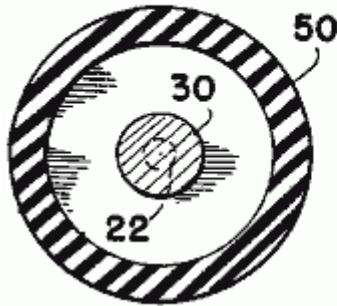

FIG. 4

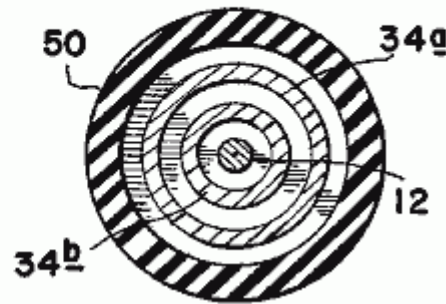

Fig.2, Fig.3, and Fig.4 show the mechanical structure of the conversion switching element tube **14**. An outer housing **50** may be of any insulative material such as glass. The anodes **12** and **22** and grids **34a** and **34b** are firmly secured by nonconductive spacer material **54**, and **56**. The resistive element **30** may be introduced into the low-voltage anode path to control the peak currents through the conversion switching element tube. The resistive element may be of a piece, or it may be built of one or more resistive elements to achieve the desired result.

The anode material may be identical for each anode, or may be of differing materials for each anode, as dictated by the most efficient utilisation of the device, as determined by appropriate research at the time of production for the intended use. The shape and spacing of the electrostatic grids is also susceptible to variation with application (voltage, current, and energy requirements).

It is the contention of the inventor that by judicious mating of the elements of the conversion switching element tube, and the proper selection of the components of the circuit elements of the system, the desired theoretical results may be achieved. It is the inventor's contention that this mating and selection process is well within the capabilities of intensive research and development technique.

Let it be stated here that substituting a source of electric alternating-current subject to the required current and/or voltage shaping and/or timing, either prior to being considered a primary energy source, or thereafter, should not be construed to change the described utilisation or application of primary energy in any way. Such energy conversion is readily achieved by any of a multitude of well established principles. The preferred embodiment of this invention merely assumes optimum utilisation and optimum benefit from this invention when used with portable energy devices similar in principle to the wet-cell or dry-cell battery.

This invention proposes to utilise the energy contained in an internally generated high-voltage electric spike (energy pulse) to electrically energise an inductive load.: this inductive load being then capable of converting the energy so supplied into a useful electrical or mechanical output.

In operation the high-voltage, short-duration electric spike is generated by discharging the capacitor **16** across the spark-gap in the conversion switching element tube. The necessary high-voltage potential is stored on the capacitor in incremental, additive steps from the bridge-type rectifier **24**. When the energy source is a direct-current electric energy storage device, such as the battery **12**, the input to the bridge rectifier is provided by the voltage step-up transformer **22**, that is in turn energised from the vibrator **20**, or solid-state chopper, or similar device to properly drive the transformer and rectifier circuits.

When the energy source is an alternating-current, switches **64** disconnect transformer **22** and the input to the bridge-type rectifier **24** is provided by the voltage step-up transformer **66**, that is in turn energised from the vibrator **20**, or solid-state chopper, or similar device to properly drive the transformer and rectifier circuits.

The repetitions output of the bridge rectifier incrementally increases the capacitor charge toward its maximum. This charge is electrically connected directly to the high-voltage anode **12** of the conversion switching element tube. When the low-voltage anode **32** is connected to a source of current, an arc is created in the spark-gap designated **62** of the conversion switching element tube equivalent to the potential stored on the high-voltage anode, and the current available from the low-voltage anode.

Because the duration of the arc is very short, the instantaneous voltage, and instantaneous current may both be very high. The instantaneous peak apparent power is therefore, also very high. Within the conversion switching element tube, this energy is absorbed by the grids **34a** and **34b** mounted circumferentially about the interior of the tube.

Control of the energy spike within the conversion switching element tube is accomplished by a mechanical, or

solid-state commutator, that closes the circuit path from the low-voltage anode to the current source at that moment when the delivery of energy to the output load is most auspicious. Any number of standard high-accuracy, variable setting devices are available for this purpose. When control of the repetitive rate of the system's output is required, it is accomplished by controlling the time of connection at the low-voltage anode.

Thus there can be provided an electrical driving system having a low-voltage source coupled to a vibrator, a transformer and a bridge-type rectifier to provide a high voltage pulsating signal to a first capacitor. Where a high-voltage source is otherwise available, it may be coupled direct to a bridge-type rectifier, causing a pulsating signal to a first capacitor. The capacitor in turn is coupled to a high-voltage anode of an electrical conversion switching element tube. The element also includes a low-voltage anode which in turn is connected to a voltage source by a commutator, a switching element tube, and a variable resistor. Mounted around the high-voltage anode is a charge receiving plate which in turn is coupled to an inductive load to transmit a high-voltage discharge from the element to the load. Also coupled to the load is a second capacitor for storing the back EMF created by the collapsing electrical field of the load when the current to the load is blocked. The second capacitor in turn is coupled to the voltage source.

ELECTRICAL MOTOR / GENERATOR

This version of the patent has been re-worded in an attempt to make it easier to read and understand. It describes the design of a pulsed electromagnet / permanent magnet motor which is capable of a higher power output than it's own power input.

ABSTRACT

An electrodynamic motor-generator has a salient pole permanent magnet rotor interacting with salient stator poles to form a machine operating on the magnetic reluctance principle. The intrinsic ferromagnetic power of the magnets provides the drive torque by bringing the poles into register whilst current pulses demagnetise the stator poles as the poles separate. In as much as less power is needed for stator demagnetisation than is fed into the reluctance drive by the thermodynamic system powering the ferromagnetic state, the machine operates regeneratively by virtue of stator winding interconnection with unequal number of rotor and stator poles. A rotor construction is disclosed (**Fig.6** and **Fig.7**). The current pulse may be such as to cause repulsion of the rotor poles.

FIELD OF THE INVENTION

This invention relates to a form of electric motor which serves a generating function in that the machine can act regeneratively to develop output electrical power or can generate mechanical drive torque with unusually high efficiency in relation to electrical power input.

The field of invention is that of switched reluctance motors, meaning machines which have salient poles and operate by virtue of the mutual magnetic attraction and/or repulsion as between magnetised poles.

The invention particularly concerns a form of reluctance motor which incorporates permanent magnets to establish magnetic polarisation.

BACKGROUND OF THE INVENTION

There have been proposals in the past for machines in which the relative motion of magnets can in some way develop unusually strong force actions which are said to result in more power output than is supplied as electrical input.

By orthodox electrical engineering principles such suggestions have seemed to contradict accepted principles of physics, but it is becoming increasingly evident that conformity with the first law of thermodynamics allows a gain in the electromechanical power balance provided it is matched by a thermal cooling.

In this sense, one needs to extend the physical background of the cooling medium to include, not just the machine structure and the immediate ambient environment, but also the sub-quantum level of what is termed, in modern physics, the zero-point field. This is the field activity of the vacuum medium which exists in the space between atomic nuclei and atomic electrons and is the seat of the action which is that associated with the Planck constant. Energy is constantly being exchanged as between that activity and coextensive matter forms but normally these energy fluctuations preserve, on balance, an equilibrium condition so that this action passes unnoticed at the technology level.

Physicists are becoming more and more aware of the fact that, as with gravitation, so magnetism is a route by which we can gain access to the sea of energy that pervades the vacuum. Historically, the energy balance has been written in mathematical terms by assigning 'negative' potential to gravitation or magnetism. However, this is only a disguised way of saying that the vacuum field, suitably influenced by the gravitating mass of a body in the locality or by magnetism in a ferromagnet has both the capacity and an urge to shed energy.

Now, however, there is growing awareness of the technological energy generating potential of this field background and interest is developing in techniques for 'pumping' the coupling between matter and vacuum field to derive power from that hidden energy source. Such research may establish that this action will draw on the

2.7K cosmic background temperature of the space medium through which the Earth travels at some 400 km/s. The effect contemplated could well leave a cool 'vapour trail' in space as a machine delivering heat, or delivering a more useful electrical form of energy that will revert to heat, travels with body Earth through that space.

In pure physics terms, relevant background is of recent record in the August 1993 issue of Physical Review E, vol. 48, pp. 1562-1565 under the title: 'Extracting energy and heat from the vacuum', authored by D. C. Cole and H. E. Puthoff. Though the connection is not referenced in that paper, one of its author's presented experimental evidence on that theme at an April 1993 conference held in Denver USA. The plasma power generating device discussed at that conference was the subject of U. S. Patent No. 5,018,180, the inventor of record being K. R. Shoulders.

The invention, to be described below, operates by extracting energy from a magnetic system in a motor and the relevant scientific background to this technology can be appreciated from the teachings of E. B. Moullin, a Cambridge Professor of Electrical Engineering who was a President of the Institution of Electrical Engineers in U. K. That prior art will be described below as part of the explanation of the operation of the invention.

The invention presented here concerns specific structural design features of a machine adapted for robust operation, but these also have novelty and special merit in a functional operation. What is described is quite distinct from prior art proposals, one being a novel kind of motor proposed by Gareth Jones at a 1988 symposium held in Hull, Canada under the auspices of the Planetary Association for Clean Energy. Jones suggested the adaptation of an automobile alternator which generates three-phase AC for rectification and use as a power supply for the electrics in the automobile. This alternator has a permanent magnet rotor and Jones suggested that it could be used, with high efficiency gain and torque performance, by operating it as a motor with the three-phase winding circuit excited so as to promote strong repulsion between the magnet poles and the stator poles after the poles had come into register.

However, the Jones machine is not one exploiting the advantages of the invention to be described, because it is not strictly a reluctance motor having salient poles on both stator and rotor. The stator poles in the Jones machine are formed by the winding configuration in a slotted stator form, the many slots being uniformly distributed around the inner circumference of the stator and not constituting a pole system which lends itself to the magnetic flux actions to be described by reference to the E. B. Moullin experiment.

The Jones machine operates by generating a rotating stator field which, in a sense, pushes the rotor poles forward rather than pulling them in the manner seen in the normal synchronous motor. Accordingly, the Jones machine relies on the electric current excitation of the motor producing a field system which rotates smoothly but has a polarity pattern which is forced by the commutation control to keep behind the rotor poles in asserting a continuous repulsive drive.

Another prior art proposal which is distinguished from this invention is that of one of the applicants, H. Aspden, namely the subject of U.K. Patent No. 2,234,863 (counterpart U.S. Patent Serial No.4,975,608). Although this latter invention is concerned with extracting energy from the field by the same physical process as the subject invention, the technique for accessing that energy is not optimum in respect of the structure or method used. Whereas in this earlier disclosure, the switching of the reluctance drive excited the poles in their approach phase, the subject invention, in one of its aspects, offers distinct advantages by demagnetisation or reversal of magnetisation in the pole separation phase of operation.

There are unexpected advantages in the implementation proposed by the subject invention, inasmuch as recent research has confirmed that it requires less input power to switch off the mutual attraction across an air gap between a magnet and an electromagnet than it does to switch it on. Usually, in electromagnetism, a reversal symmetry is expected, arising from conventional teaching of the way forward and back magnetomotive forces govern the resulting flux in a magnetic circuit.

This will be further explained after describing the scope of the invention.

BRIEF DESCRIPTION OF THE INVENTION

According to one aspect of the invention, an electrodynamic motor/generator machine comprises a stator configured to provide a set of stator poles, a corresponding set of magnetising windings mounted on the stator pole set, a rotor having two sections each of which has a set of salient pole pieces, the rotor sections being axially spaced along the axis of rotation of the rotor, rotor magnetisation means disposed between the two rotor sections arranged to produce a unidirectional magnetic field which magnetically polarises the rotor poles, whereby the pole faces of one rotor section all have a north polarity and the pole faces of the other rotor section all have a south polarity and electric circuit connections between an electric current source and the stator magnetising windings arranged to regulate the operation of the machine by admitting current pulses for a duration determined according

to the angular position of the rotor, which pulses have a direction tending to oppose the polarisation induced in the stator by the rotor polarisation as stator and rotor poles separate from an in-register position, whereby the action of the rotor magnetisation means provides a reluctance motor drive force to bring stator and rotor poles into register and the action of the stator magnetisation windings opposes the counterpart reluctance braking effect as the poles separate.

According to a feature of the invention, the circuit connecting the electric current source and the stator magnetising windings is designed to deliver current pulses which are of sufficient strength and duration to provide demagnetisation of the stator poles as the stator and rotor poles separate from an in-register position.

In this regard it is noted that in order to suppress the reluctance drive torque or brake torque, depending upon whether poles are converging or separating, a certain amount of electrical power must be fed to the magnetising windings on the stator. In a sense these windings are really 'demagnetising windings' because the polarity of the circuit connections admit the pulse current in the demagnetising direction.

However, it is more usual to refer to windings on magnetic cores as 'magnetising windings' even though they can function as primary windings or secondary windings, the former serving the magnetisation function with input power and the latter serving a demagnetising function with return of power.

According to another feature of the invention, the circuit connecting the electric current source and the stator magnetising windings is designed to deliver current pulses which are of sufficient strength and duration to provide a reversal of magnetic flux direction in the stator poles as the stator and rotor poles separate from an in-register position, whereby to draw on power supplied from the electric current source to provide additional forward drive torque.

According to a further feature of the invention, the electric current source connected to a stator magnetising winding of a first stator pole comprises, at least partially, the electrical pulses induced in the stator magnetising winding of a different second stator pole, the stator pole set configuration in relation to the rotor pole set configuration being such that the first stator pole is coming into register with a rotor pole as the second stator pole separates from its in-register position with a rotor pole.

This means that the magnetising windings of two stator poles are connected so that both serve a 'demagnetising' function, one in resisting the magnetic action of the mutual attraction in pulling poles into register, an action which develops a current pulse output and one in absorbing this current pulse, again by resisting the magnetic inter-pole action to demagnetise the stator pole as its associated rotor pole separates.

In order to facilitate the function governed by this circuit connection between stator magnetising windings, a phase difference is needed and this is introduced by designing the machine to have a different number of poles in a set of stator poles from the number of rotor poles in each rotor section. Together with the dual rotor section feature, this has the additional merit of assuring a smoother torque action and reducing magnetic flux fluctuations and leakage effects which contribute substantially to machine efficiency.

Thus, according to another feature of the invention, the stator configuration provides pole pieces which are common to both rotor sections in the sense that when stator and rotor poles are in-register the stator pole pieces constitute bridging members for magnetic flux closure in a magnetic circuit including that of the rotor magnetisation means disposed between the two rotor sections.

Preferably, the number of poles in a set of stator poles and the number of rotor poles in each section do not share a common integer factor, the number of rotor poles in one rotor section is the same as that in the other rotor section and the number of poles in a stator set and the number of poles in a rotor section differs by one, with the pole faces being of sufficient angular width to assure that the magnetic flux produced by the rotor magnetisation means can find a circular magnetic flux closure route through the bridging path of a stator pole and through corresponding rotor poles for any angular position of the rotor.

It is also preferable from a design viewpoint for the stator pole faces of this invention to have an angular width that is no greater than half the angular width of a rotor pole and for the rotor sections to comprise circular steel laminations in which the rotor poles are formed as large teeth at the perimeter with the rotor magnetisation means comprising a magnetic core structure the end faces of which abut two assemblies of such laminations forming the two rotor sections.

According to a further feature of the invention, the rotor magnetisation means comprises at least one permanent magnet located with its polarisation axis parallel with the rotor axis. The motor-generator may include an apertured metal disc that is of a non-magnetisable substance mounted on a rotor shaft and positioned intermediate the two rotor sections, each aperture providing location for a permanent magnet, whereby the centrifugal forces acting on the permanent magnet as the rotor rotates are absorbed by the stresses set up in the

disc. Also, the rotor may be mounted on a shaft that is of a non-magnetisable substance, whereby to minimise magnetic leakage from the rotor magnetising means through that shaft.

According to another aspect of the invention, an electrodynamic motor-generator machine comprises a stator configured to provide a set of stator poles, a corresponding set of magnetising windings mounted on the stator pole set, a rotor having two sections each of which has a set of salient pole pieces, the rotor sections being axially spaced along the axis of rotation of the rotor, rotor magnetisation means incorporated in the rotor structure and arranged to polarise the rotor poles, whereby the pole faces of one rotor section all have a north polarity and the pole faces of the other rotor section all have a south polarity and electric circuit connections between an electric current source and the stator magnetising windings arranged to regulate the operation of the machine by admitting current pulses for a duration determined according to the angular position of the rotor, which pulses have a direction tending to oppose the polarisation induced in the stator by the rotor polarisation as stator and rotor poles separate from an in-register position, whereby the action of the rotor magnetisation means provides a reluctance motor drive force to bring stator and rotor poles into register and the action of the stator magnetisation windings opposes the counterpart reluctance braking effect as the poles separate.

According to a feature of this latter aspect of the invention, the electric current source connected to a stator magnetising winding of a first stator pole comprises, at least partially, the electrical pulses induced in the stator magnetising winding of a different second stator pole, the stator pole set configuration in relation to the rotor pole set configuration being such that the first stator pole is coming into register with a rotor pole as the second stator pole separates from its in-register position with a rotor pole.

BRIEF DESCRIPTION OF THE DRAWINGS

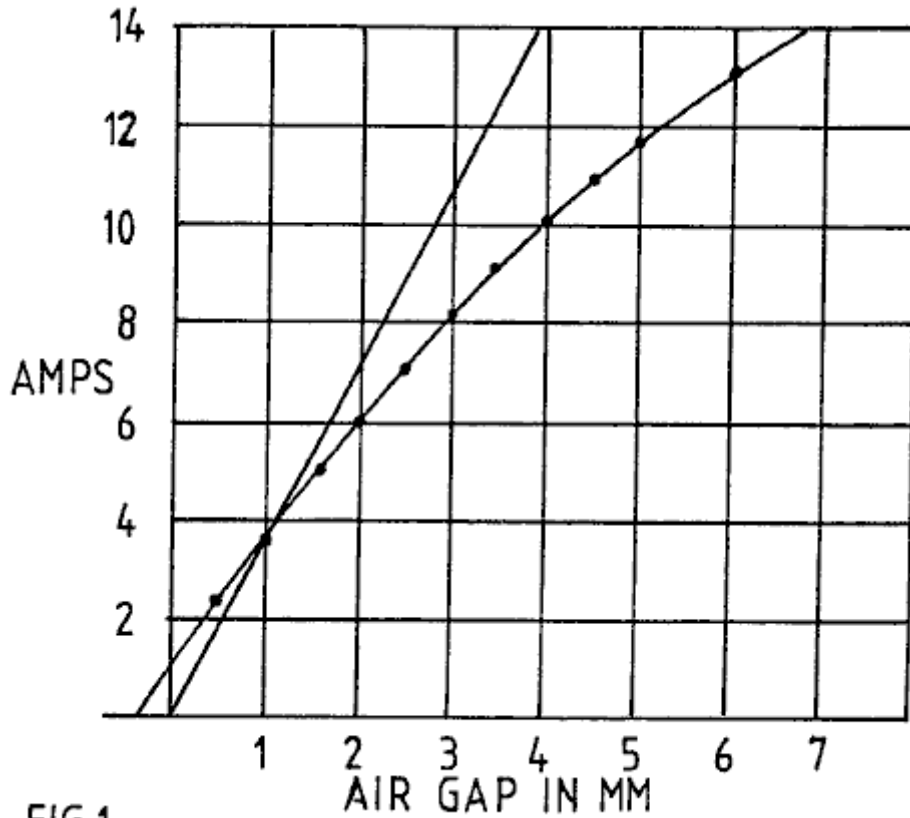

FIG.1

Fig.1 presents magnetic core test data showing how the volt-amp reactance power required to set up a constant magnetic flux action in an air gap, as assured by constant AC voltage excitation of a magnetising winding, falls short of the associated power of the potential implicit in the force action across that air gap.

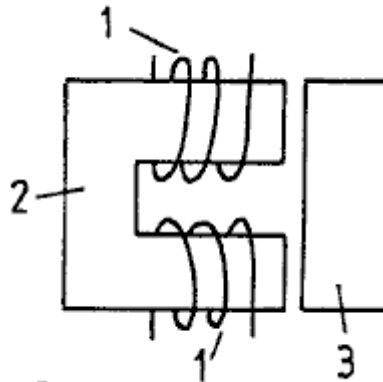

FIG.2

Fig.2 depicts the test structure to which Fig. 1 data applies.

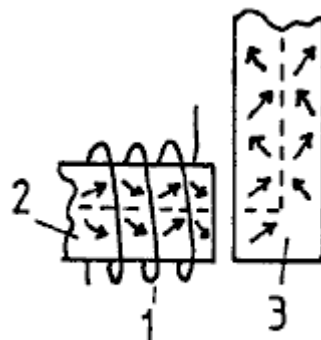

FIG.3

Fig.3 depicts the magnetisation action at work in causing magnetic flux to traverse an air-gap and turn a corner in a circuit through a magnetic core.

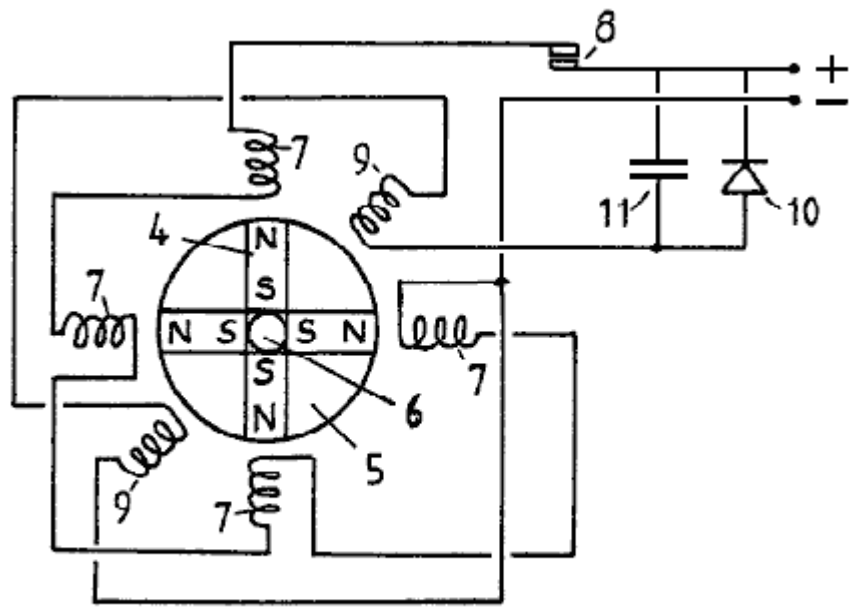

FIG. 4

Fig.4 shows the configuration of a test device used to prove the operating principles of the invention described.

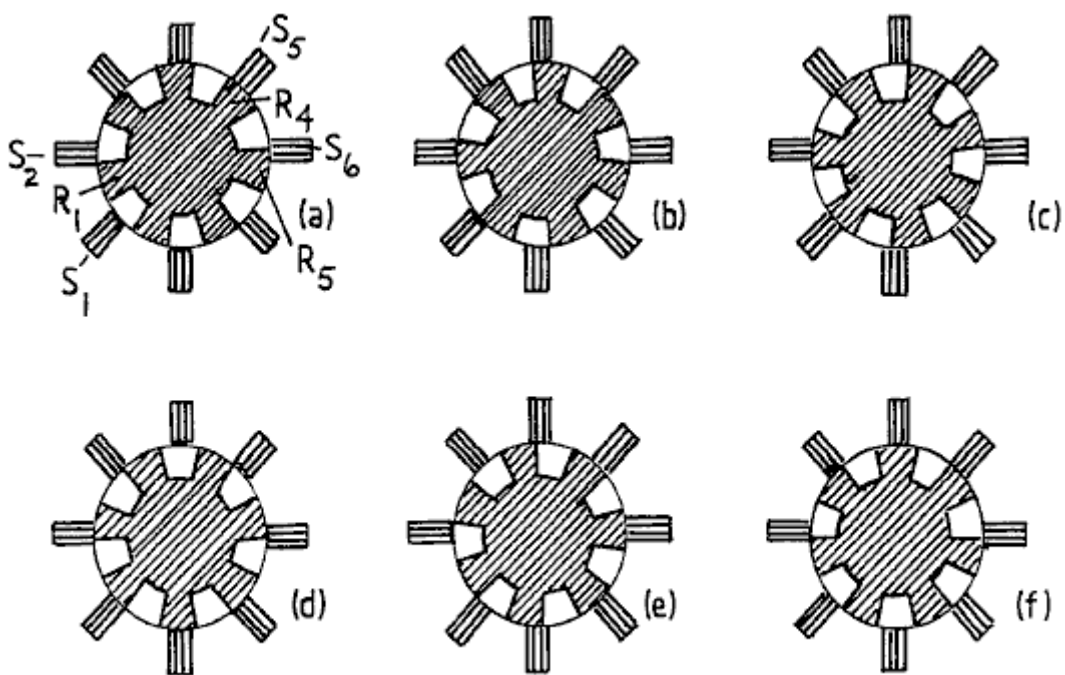

FIG.5

Fig.5 in its several illustrations depicts the progressive rotor pole to stator pole relationship as a rotor turns through a range of angular positions in a preferred embodiment of a machine according to the invention.

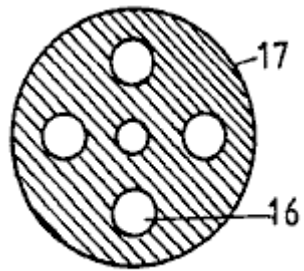

FIG. 6

Fig.6 shows the form of a disc member which provides location for four permanent magnets in the machine described.

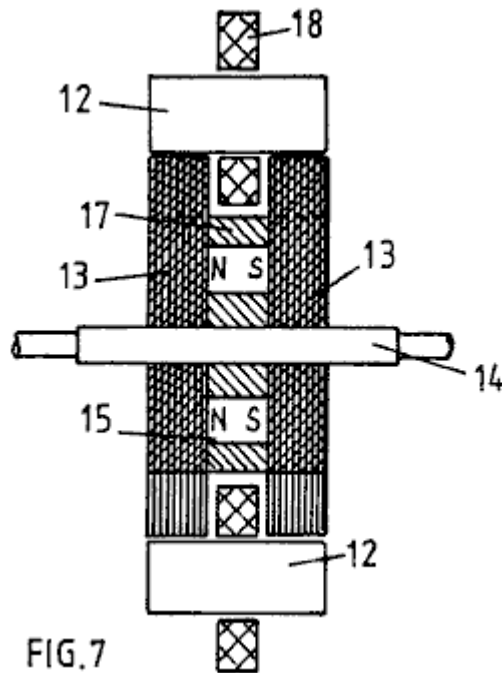

FIG.7

Fig.7 shows a cross-section of the magnetic circuit structure of a machine embodying the invention.

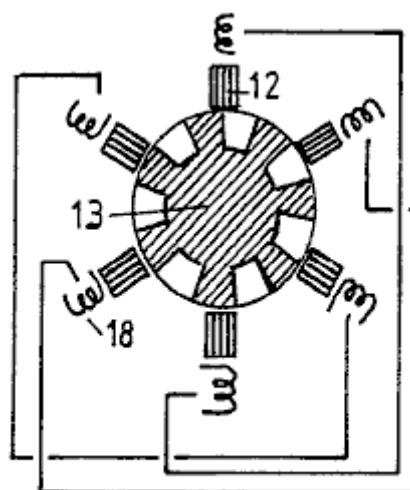

FIG.8

Fig.8 shows a six stator pole configuration with a seven pole rotor and depicts a schematic series connected linking of the magnetising windings of diametrically opposite stator poles.

DETAILED DESCRIPTION OF THE INVENTION

The fact that one can extract energy from the source which powers the intrinsic ferromagnetic state is not explicitly evident from existing textbooks, but it is implicit and, indeed, does become explicit once pointed out, in one textbook authored by E. B. Moullin. His book 'The Principles of Electromagnetism' published by Clarendon Press, Oxford (3rd Edition, 1955) describes on pages 168-174 an experiment concerned with the effect of air gaps between poles in a magnetic circuit. The data obtained are reproduced in **Fig.1**, where Professor Moullin shows a curve representing AC current input for different air gaps, given that the voltage supplied is constant. In the same figure, Moullin presents the theoretical current that would need to be applied to sustain the same voltage, and so the related pole forces across the air gap, assuming (a) no flux leakage and (b) that there is complete equality between inductive energy input and the mechanical energy potential for the magnetisation that is established in the air gap in a quarter-cycle period at the AC power excitation frequency.

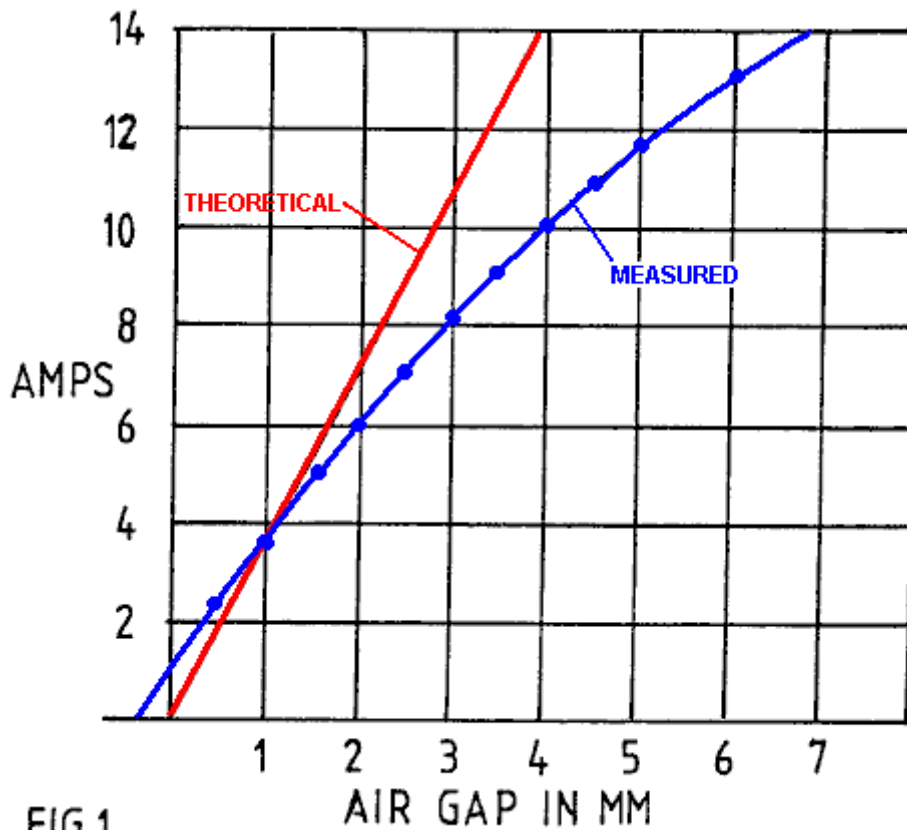

FIG.1

The data show that, even though the level of magnetic polarisation is well below the saturation value, being confined to a range that is regarded as the linear permeability range in transformer design, there is a clear drop-off of current, and so the volt-amp reactive power input needed, as current increases, compared with that predicted by the mechanical potential built up in the air gaps. Unless leakage flux is excessive, here was clear evidence of anomalous energy activity.

Moullin discusses the leakage flux inferred by this experiment but points out that there is considerable mystery in why the effect of a small gap, which should certainly not result in much flux leakage in the gap region, nevertheless has an enormous effect in causing what has to be substantial leakage in the light of the energy discrepancy. Moullin did not contemplate that energy had been fed in from the zero-point field system and so he left the issue with the statement that it was virtually impossible to predict leakage flux by calculation.

He was, of course, aware of magnetic domain structure and his argument was that the leakage flux problem was connected with what he termed a 'yawing' action of the flux as it passes around the magnetic circuit. Normally, provided the level of polarisation is below the knee of the B-H curve, which occurs at about 70% of saturation in iron cores of general crystal composition, it requires very little magnetising field to change the magnetic flux density. This is assuming that every effort is made to avoid air gaps. The action involves domain wall movements so that the magnetic states of adjacent domains switch to different crystal axes of easy magnetisation and this involves very little energy change.

However, if there is an air gap ahead in the flux circuit and the magnetising winding is not sitting on that air gap, the iron core itself has to be the seat of a progressive field source linking the winding and the gap. It can only serve in that sense by virtue of the lines of flux in the domains being forced to rotate somewhat from the preferred easy axes of magnetisation, with the help of the boundary surfaces around the whole core. This action means that, forcibly, and consequential upon the existence of the air gap, the flux must be carried through the core by

that 'yawing' action. It means that substantial energy is needed to force the establishment of those fields within the iron core. More important, however, from the point of view of this invention, it means that the intrinsic magnetic polarisation effects in adjacent magnetic domains in the iron cease to be mutually parallel or orthogonal so as to stay directed along axes of easy magnetisation. Then, in effect, the magnetising action is not just that of the magnetising winding wrapped around the core but becomes also that of adjacent ferromagnetic polarisation as the latter act in concert as vacuum-energy powered solenoids and are deflected into one another to develop the additional forward magnetomotive forces.

The consequences of this are that the intrinsic ferromagnetic power source with its thermodynamic ordering action contributes to doing work in building up forces across the air gap. The task, in technological terms, is then to harness that energy as the gap is closed, as by poles coming together in a reluctance motor, and avoid returning that energy as the poles separate, this being possible if the controlling source of primary magnetisation is well removed from the pole gap and the demagnetisation occurs when the poles are at the closest position.

This energy situation is evident in the Moullin data, because the constant AC voltage implies a constant flux amplitude across the air gap if there is no flux leakage in the gap region. A constant flux amplitude implies a constant force between the poles and so the gap width in relation to this force is a measure of the mechanical energy potential of the air gap. The reactive volt-amp power assessment over the quarter-cycle period representing the polarisation demand can then be compared with the mechanical energy so made available. As already stated, this is how Moullin deduced the theoretical current curve. In fact, as his data show, he needed less current than the mechanical energy suggested and so he had in his experiment evidence of the vacuum energy source that passed unnoticed and is only now revealing itself in machines that can serve our energy needs.

In the research leading to this patent application the Moullin experiment has been repeated to verify a condition where a single magnetising winding serves three air gaps. The Moullin test configuration is shown in **Fig.2**, but in repeating the experiment in the research leading to this invention, a search coil was mounted on the bridging member and this was used to compare the ratio of the voltage applied to the magnetising winding and that induced in the search coil.

The same fall-off feature in current demand was observed, and there was clear evidence of substantial excess energy in the air gap. This was in addition to the inductive energy that necessarily had to be locked into the magnetic core to sustain the 'yawing' action of the magnetic flux already mentioned.

It is therefore emphasised that, in priming the flux 'yawing' action, energy is stored inductively in the magnetic core, even though this has been deemed to be the energy of flux leakage outside the core. The air gap energy is also induction energy. Both energies are returned to the source winding when the system is demagnetised, given a fixed air gap.

If, however, the air gap closes after or during magnetisation, much of that inductive energy goes into the mechanical work output. Note then that the energy released as mechanical work is not just that stored in the air gap but is that stored in sustaining the 'yaw'. Here, then is reason to expect an even stronger contribution to the dynamic machine performance, one that was not embraced by the calculation of the steady-state situation.

Given the above explanation of the energy source, the structural features which are the subject of this invention will now be described.

The 'yawing' action is depicted in **Fig.3**, which depicts how magnetic flux navigates a right-angled bend in a magnetic core upon passage through an air gap. By over-simplification it is assumed that the core has a crystal structure that has a preferred axis of magnetisation along the broken line path. With no air gap, the current needed by a magnetising winding has only to provide enough magnetomotive force to overcome the effects of non-magnetic inclusions and impurities in the core substance and very high magnetic permeabilities can apply. However, as soon as the air gap develops, this core substance has to find a way of setting up magnetomotive force in regions extending away from the locality of the magnetising winding. It cannot do this unless its effect is so powerful that the magnetic flux throughout the magnetic circuit through the core substance is everywhere deflected from alignment with a preferred easy axis of magnetisation. Hence the flux vectors depicted by the arrows move out of alignment with the broken line shown.

There is a 'knock-on' effect progressing all the way around the core from the seat of the magnetising winding and, as already stated, this harnesses the intrinsic ferromagnetic power that, in a system with no air gap, could only be affected by magnetisation above the knee of the B-H curve. Magnetic flux rotation occurs above that knee, whereas in an ideal core the magnetism develops with very high permeability over a range up to that knee, because it needs very little power to displace a magnetic domain wall sideways and promote a 900 or a1800 flux reversal. Indeed, one can have a magnetic permeability of 10,000 below the knee and 100 above the knee, the latter reducing progressively until the substance saturates magnetically.

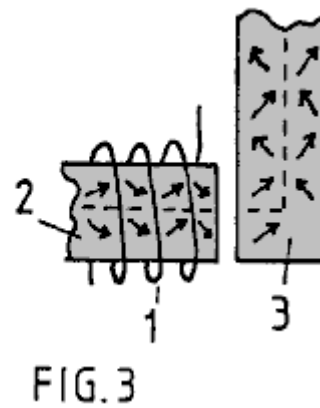
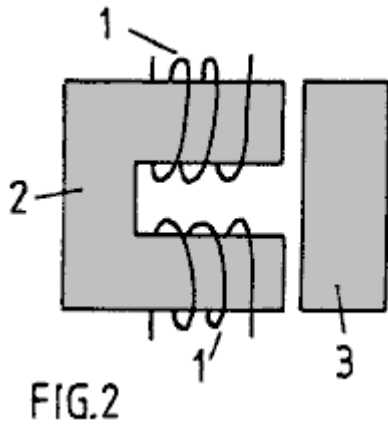

In the situation depicted in **Fig.2** and **Fig.3** the field strength developed by the magnetising windings **1** on magnetic core **2** has to be higher, the greater the air gap, in order to achieve the same amount of magnetisation as measured by the voltage induced in a winding (not shown) on the bridging member **3**. However, by virtue of that air gap there is potential for harnessing energy supplied to that air gap by the intrinsic zero-point field that accounts for the magnetic permeability being over unity and here one can contemplate very substantial excess energy potential, given incorporation in a machine design which departs from convention.

One of the applicants has built an operative test machine which is configured as depicted schematically in **Fig.4**. The machine has been proved to deliver substantially more mechanical power output than is supplied as electrical input, as much as a ratio of 7:1 in one version, and it can act regeneratively to produce electrical power.

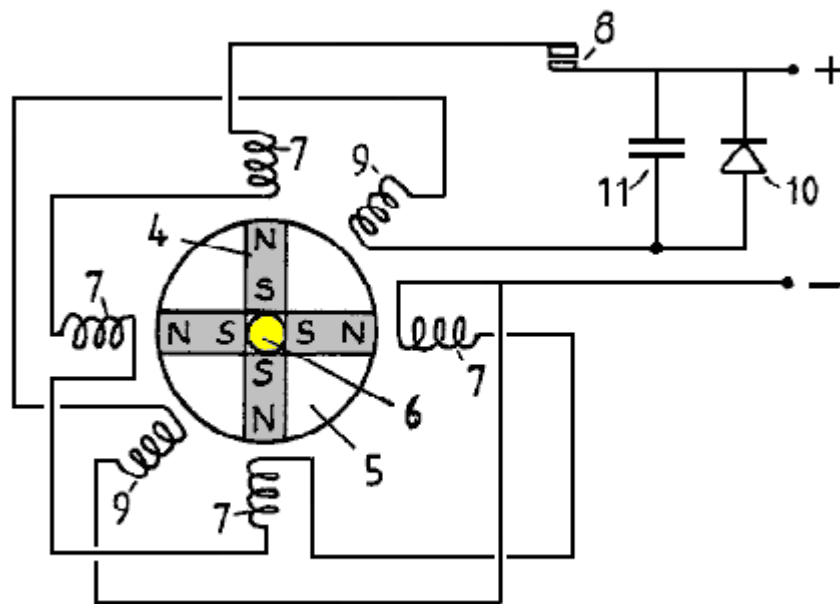

FIG. 4

What is shown in **Fig.4** is a simple model designed to demonstrate the principle of operation. It comprises a rotor in which four permanent magnets **4** are arrayed to form four poles. The magnets are bonded into four sectors of a non-magnetic disc **5** using a high density polyurethane foam filler and the composite disc is then assembled on a brass spindle **6** between a split flange coupling. Not shown in the figure is the structure holding the spindle vertically in bearings or the star wheel commutator assembly attached to the upper shaft of the spindle.

Note that the magnets present north poles at the perimeter of the rotor disc and that the south poles are held together by being firmly set in the bonding material. A series of four stator poles were formed using magnetic cores from standard electromagnetic relays are were positioned around the rotor disc as shown. The magnetising windings **7** on these cores are shown to be connected in series and powered through commutator contacts **8** by a DC power supply. Two further stator cores formed by similar electromagnetic relay components are depicted by their windings **9** in the intermediate angle positions shown and these are connected in series and connected to a rectifier **10** bridged by a capacitor **11**.

The rotor spindle **6** is coupled with a mechanical drive (not shown) which harnesses the torque developed by the motor thus formed and serves as a means for measuring output mechanical power delivered by the machine.

In operation, assuming that the rotor poles are held initially off-register with the corresponding stator poles and the hold is then released, the strong magnetic field action of the permanent magnets will turn the rotor to bring the stator and rotor poles into register. A permanent magnet has a strong attraction for soft iron and so this initial impulse of rotation is powered by the potential energy of the magnets.

Now, with the rotor acting as a flywheel and having inertia it will have a tendency to over-shoot the in-register pole position and that will involve a reverse attraction with the result that the rotor will oscillate until damping action brings it to rest. However, if the contacts of the commutating switch are closed as the poles come

The commutating switch **8** needs only to be closed for a limited period of angular travel following the top dead centre in-register position of the stator and rotor poles. The power supplied through that switch by those pulses will cause the rotor to continue rotating and high speeds will be achieved as the machine develops its full motor function.

Tests on such a machine have shown that more mechanical power can be delivered than is supplied electrically by the source powering the action through the commutating switch. The reason for this is that, whereas the energy in the air gap between rotor and stator poles which is tapped mechanically as the poles come into register is provided by the intrinsic power of the ferromagnet, a demagnetising winding on the part of the core system coupled across that air gap needs very little power to eliminate the mechanical force acting across that air gap. Imagine such a winding on the bridging member shown in **Fig.2**. The action of current in that winding, which sits astride the 'yawing' flux in that bridging member well removed from the source action of the magnetising windings **1**, is placed to be extremely effective in resisting the magnetising influence communicated from a distance. Hence very little power is needed to overcome the magnetic coupling transmitted across the air gap.

Although the mutual inductance between two spaced-apart magnetising windings has a reciprocal action, regardless of which winding is primary and which is secondary, the action in the particular machine situation being described involves the 'solenoidal' contribution represented by the 'yawing' ferromagnetic flux action. The latter is not reciprocal inasmuch as the flux 'yaw' depends on the geometry of the system. A magnetising winding directing flux directly across an air gap has a different influence on the action in the ferromagnetic core from one directing flux lateral to the air gap and there is no reciprocity in this action.

In any event, the facts of experiment do reveal that, owing to a significant discrepancy in such mutual interaction, more mechanical power is fed into the rotor than is supplied as input from the electrical source.

This has been further demonstrated by using the two stator windings **9** to respond in a generator sense to the passage of the rotor poles. An electrical pulse is induced in each winding by the passage of a rotor pole and this is powered by the inertia of the rotor disc **5**. By connecting the power so generated, to charge the capacitor **11**, the DC power supply can be augmented to enhance the efficiency even further.

Indeed, the machine is able to demonstrate the excess power delivery from the ferromagnetic system by virtue of electrical power generation charging a battery at a greater rate than a supply battery is discharged.

This invention is concerned with a practical embodiment of the motor-generator principles just described and aims, in its preferred aspect, to provide a robust and reliable machine in which the tooth stresses in the rotor poles, which are fluctuating stresses communicating high reluctance drive torque, are not absorbed by a ceramic permanent magnet liable to rupture owing to its brittle composition.

Another object is to provide a structure which can be dismantled and reassembled easily to replace the permanent magnets, but an even more important object is that of minimising the stray leakage flux oscillations from the powerful permanent magnets. Their rotation in the device depicted in **Fig.4** would cause excessive eddy-current induction in nearby metal, including that of the machine itself, and such effects are minimised if the flux changes are confined to paths through steel laminations and if the source flux from the magnets has a symmetry or near symmetry about the axis of rotation.

Thus, the ideal design with this in mind is one where the permanent magnet is a hollow cylinder located on a non-magnetic rotor shaft, but, though that structure is within the scope of this invention, the machine described will utilise several separate permanent magnets approximating, in function, such a cylindrical configuration.

Referring to **Fig.4**, it will further be noted that the magnetic flux emerging from the north poles will have to find its way along leakage paths through air to re-enter the south poles. For periods in each cycle of machine operation

the flux will be attracted through the stator cores, but the passage through air is essential and so the power of the magnets is not used to full advantage and there are those unwanted eddy-current effects.

To overcome this problem the invention provides for two separate rotor sections and the stator poles become bridging members, which with optimum design, allow the flux from the magnets to find a route around a magnetic circuit with minimal leakage through air as the flux is directed through one or other pairs of air gaps where the torque action is developed.

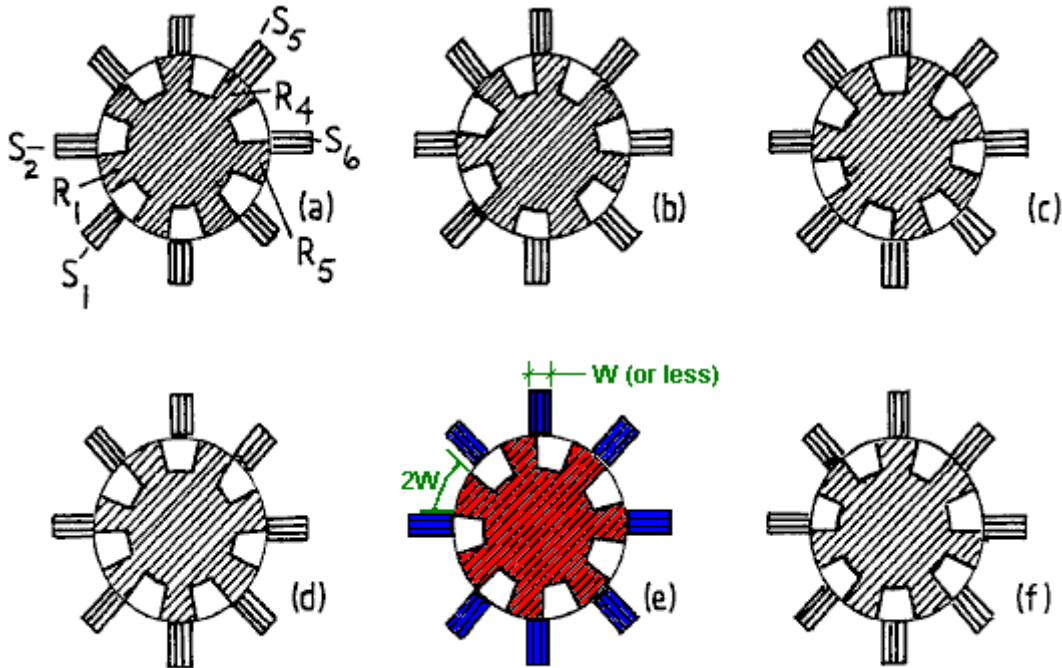

FIG. 5

Reference is now made to **Fig.5** and the sequence of rotor positions shown. Note that the stator pole width can be significantly smaller than that of the rotor poles. Indeed, for operation using the principles of this invention, it is advantageous for the stator to have a much smaller pole width so as to concentrate the effective pole region. A stator pole width of half that of the rotor is appropriate but it may be even smaller and this has the secondary advantage of requiring smaller magnetising windings and so saving on the loss associated with the current circuit.

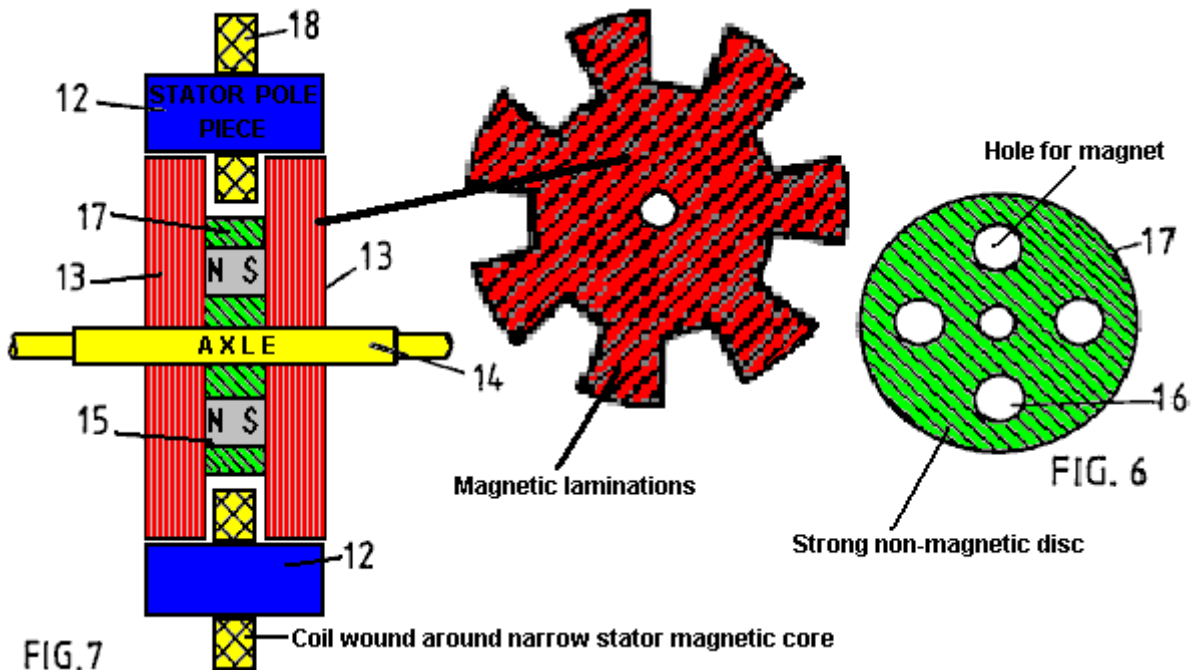

FIG. 7

The stator has eight pole pieces formed as bridging members **12**, more clearly represented in **Fig.7**, which shows a sectional side view through two rotor sections **13** axially spaced on a rotor shaft **14**. There are four permanent magnets **15** positioned between these rotor sections and located in apertures **16** in a disc **17** of a non-magnetic

substance of high tensile strength, the latter being shown in **Fig.6**. The rotor sections are formed from disc laminations of electrical steel which has seven large teeth, the salient poles. Magnetising windings **18** mounted on the bridging members **12** constitute the system governing the action of the motor-generator being described.

The control circuitry is not described as design of such circuitry involves ordinary skill possessed by those involved in the electrical engineering art.

It suffices, therefore, to describe the merits of the structural design configuration of the core elements of the machine. These concern principally the magnetic action and, as can be imagined from **Fig.7**, the magnetic flux from the magnets enters the rotor laminations by traversing the planar faces of the laminations and being deflected into the plane of the laminations to pass through one or other of the stator pole bridging members, returning by a similar route through the other rotor.

By using eight stator poles and seven rotor poles, the latter having a pole width equal to half the pole pitch in an angular sense, it will be seen from **Fig.5**, that there is always a flux passage across the small air gap between stator and rotor poles. However, as one pole combination is in-register the diametrically-opposed pole combinations are out-of register.

As described by reference to **Fig.4** the operation of the machine involves allowing the magnet to pull stator and rotor poles into register and then, as they separate, pulsing the winding on the relevant stator member to demagnetise that member. In the **Fig.4** system, all the stator magnetising windings were pulsed together, which is not an optimum way in which to drive a multi-pole machine.

In the machine having the pole structure with one less rotor pole than stator poles (or an equivalent design in which there is one less stator pole than rotor poles) this pulsing action can be distributed in its demand on the power supply, and though this makes the commutation switch circuit more expensive the resulting benefit outweighs that cost. However, there is a feature of this invention by which that problem can be alleviated if not eliminated.

Suppose that the rotor has the position shown in **Fig.5(a)** with the rotor pole denoted **R1** midway between stator poles **S1** and **S2** and imagine that this is attracted towards the in-register position with stator pole **S2**. Upon reaching that in-register position, as shown in **Fig.5(c)**, suppose that the magnetising winding of stator pole **S2** is excited by a current pulse which is sustained until the rotor reaches the **Fig.5(e)** position.

The combination of these two actions will have imparted a forward drive impulse powered by the permanent magnet in the rotor structure and the current pulse which suppresses braking action will have drawn a smaller amount of energy from the electrical power source which supplies it. This is the same process as was described by reference to **Fig.4**.

However, now consider the events occurring in the rotor action diametrically opposite that just described. In the **Fig.5(a)** position rotor pole **R4** has come fully into register with stator pole **S5** and so stator pole **S5** is ready to be demagnetised. However, the magnetic coupling between the rotor and stator poles is then at its strongest. Note, however, that in that **Fig.5(a)** position **R5** is beginning its separation from stator poles and the magnetising winding of stator pole **S6** must then begin draw power to initiate demagnetisation. During that following period of pole separation the power from the magnet is pulling **R1** and **S2** together with much more action than is needed to generate that current pulse needed to demagnetise **S6**. It follows, therefore, that, based on the research findings of the regenerative excitation in the test system of **Fig.4**, the series connection of the magnetising windings on stators **S2** and **S6** will, without needing any commutative switching, provide the regenerative power needed for machine operation.

The complementary action of the two magnetising windings during the pole closure and pole separation allows the construction of a machine which, given that the zero-point vacuum energy powering the ferromagnet is feeding input power, will run on that source of energy and thereby cool the sustaining field system.

There are various design options in implementing what has just been proposed. Much depends upon the intended use of the machine. If it is intended to deliver mechanical power output the regenerative electrical power action can all be used to power the demagnetisation with any surplus contributing to a stronger drive torque by reversing the polarity of the stator poles during pole separation.

If the object is to generate electricity by operating in generator mode then one could design a machine having additional windings on the stator for delivering electrical power output. However, it seems preferable to regard the machine as a motor and maximise its efficiency in that capacity whilst using a mechanical coupling to an alternator of conventional design for the electrical power generation function.

In the latter case it would still seem preferable to use the self-excitation feature already described to reduce commutation switching problems.

The question of providing for machine start-up can be addressed by using a separate starter motor powered from an external supply or by providing for current pulsing limited to, say, two stator poles. Thus, for example, with the eight stator pole configuration, the cross-connected magnetising windings could be limited to three stator pairs, with two stator magnetising windings left free for connection to a pulsed external supply source.

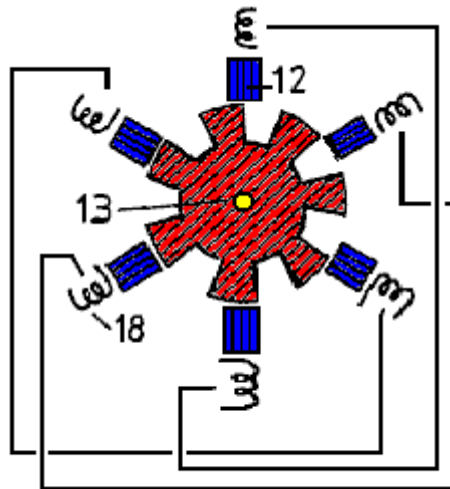

FIG.8

If the latter feature were not required, then the stator magnetising windings would all be connected in pairs on a truly diametrically opposite basis. Thus **Fig.8** shows a rotor-stator configuration having six stator poles interacting with seven rotor poles and stator magnetising windings linked together in pairs.

The invention, therefore, offers a wide range of implementation possibilities, which, in the light of this disclosure will become obvious to persons skilled in the electrical engineering art, all based, however, on the essential but simple principle that a rotor has a set of poles of common polarity which are attracted into register with a set of stator poles that are suppressed or reversed in polarity magnetically during pole separation. The invention, however, also offers the important feature of minimising commutation and providing further for a magnetic flux closure that minimises the leakage flux and fluctuations of leakage flux and so contributes to efficiency and high torque performance as well as durability and reliability of a machine incorporating the invention.

It is noted that although a machine has been described which uses two rotor sections it is possible to build a composite version of the machine having several rotor sections. In the eventuality that the invention finds use in very large motor-generator machines the problem of providing very large magnets can be overcome by a design in which numerous small magnets are assembled. The structural concept described by reference to **Fig.6** in providing locating apertures to house the magnets makes this proposal highly feasible. Furthermore, it is possible to replace the magnets by a steel cylinder and provide a solenoid as part of the stator structure and located between the rotor sections. This would set up an axial magnetic field magnetising the steel cylinder and so polarising the rotor. However, the power supplied to that solenoid would detract from the power generated and so such a machine would not be as effective as the use of permanent magnets such as are now available.

Nevertheless, should one see significant progress in the development of warm superconductor materials, it may become feasible to harness the self-generating motor-generator features of the invention, with its self-cooling properties, by operating the device in an enclosure at low temperatures and replacing the magnets by a superconductive stator supported solenoid.

CLAIMS

1. An electrodynamic motor-generator machine comprising a stator configured to provide a set of stator poles, a corresponding set of magnetising windings mounted on the stator pole set, a rotor having two sections each of which has a set of salient pole pieces, the rotor sections being axially spaced along the axis of rotation of the rotor, rotor magnetisation means disposed between the two rotor sections arranged to produce a unidirectional magnetic field which magnetically polarises the rotor poles, whereby the pole faces of one rotor section all have a north polarity and the pole faces of the other rotor section all have a south polarity and electric circuit connections between an electric current source and the stator magnetising windings arranged to regulate the operation of the machine by admitting current pulses for a duration determined according to the angular position of the rotor, which pulses have a direction tending to oppose the polarisation induced in the stator by

the rotor polarisation as stator and rotor poles separate from an in-register position, whereby the action of the rotor magnetisation means provides a reluctance motor drive force to bring stator and rotor poles into register and the action of the stator magnetisation windings opposes the counterpart reluctance braking effect as the poles separate.

2. A motor-generator according to claim 1, wherein the circuit connecting the electric current source and the stator magnetising windings is designed to deliver current pulses which are of sufficient strength and duration to provide demagnetisation of the stator poles as the stator and rotor poles separate from an in-register position.
3. A motor-generator according to claim 1, wherein the circuit connecting the electric current source and the stator magnetising windings is designed to deliver current pulses which are of sufficient strength and duration to provide a reversal of magnetic flux direction in the stator poles as the stator and rotor poles separate from an in-register position, whereby to draw on power supplied from the electric current source to provide additional forward drive torque.
4. A motor-generator according to claim 1, wherein the electric current source connected to a stator magnetising winding of a first stator pole comprises, at least partially, the electrical pulses induced in the stator magnetising winding of a different second stator pole, the stator pole set configuration in relation to the rotor pole set configuration being such that the first stator pole is coming into register with a rotor pole as the second stator pole separates from its in-register position with a rotor pole.
5. A motor-generator according to claim 1, wherein the number of poles in a set of stator poles is different from the number of rotor poles in each rotor section.
6. A motor-generator according to claim 1, wherein the stator configuration provides pole pieces which are common to both rotor sections in the sense that when stator and rotor poles are in-register the stator pole pieces constitute bridging members for magnetic flux closure in a magnetic circuit including that of the rotor magnetisation means disposed between the two rotor sections.
7. A motor-generator according to claim 6, wherein the number of poles in a set of stator poles and the number of rotor poles in each section do not share a common integer factor and the number of rotor poles in one rotor section is the same as that in the other rotor section.
8. A motor-generator according to claim 7, wherein the number of poles in a stator set and the number of poles in a rotor section differs by one and the pole faces are of sufficient angular width to assure that the magnetic flux produced by the rotor magnetisation means can find a circuital magnetic flux closure route through the bridging path of a stator pole and through corresponding rotor poles for any angular position of the rotor.
9. A motor-generator according to claim 8, wherein each rotor section comprises seven poles.
10. A motor-generator according to claim 7, wherein there are N rotor poles in each rotor section and each has an angular width that is $180/N$ degree of angle.
11. A motor-generator according to claim 7, wherein the stator pole faces have an angular width that is no greater than half the angular width of a rotor pole.
12. A motor-generator according to claim 1, wherein the rotor sections comprise circular steel laminations in which the rotor poles are formed as large teeth at the perimeter, and the rotor magnetisation means comprise a magnetic core structure the end faces of which about two assemblies of such laminations forming the two rotor sections.
13. A motor-generator according to claim 1 in which the rotor magnetisation means comprises at least one permanent magnet located with its polarisation axis parallel with the rotor axis.
14. A motor-generator according to claim 13, wherein an apertured metal disc that is of a non-magnetisable substance is mounted on a rotor shaft and positioned intermediate the two rotor sections and each aperture provides location for a permanent magnet, whereby the centrifugal forces acting on the permanent magnet as the rotor rotates are absorbed by the stresses set up in the disc.
15. A motor-generator according to claim 1, having a rotor mounted on a shaft that is of a non-magnetisable substance, whereby to minimise magnetic leakage from the rotor magnetising means.
16. An electrodynamic motor-generator machine comprising a stator configured to provide a set of stator poles, a corresponding set of magnetising windings mounted on the stator pole set, a rotor having two sections each of which has a set of salient pole pieces, the rotor sections being axially spaced along the axis of rotation of the

rotor, rotor magnetisation means incorporated in the rotor structure and arranged to polarise the rotor poles, whereby the pole faces of one rotor section all have a north polarity and the pole faces of the other rotor section all have a south polarity and electric circuit connections between an electric current source and the stator magnetising windings arranged to regulate the operation of the machine by admitting current pulses for a duration determined according to the angular position of the rotor, which pulses have a direction tending to oppose the polarisation induced in the stator by the rotor polarisation as stator and rotor poles separate from an in-register position, whereby the action of the rotor magnetisation means provides a reluctance motor drive force to bring stator and rotor poles into register and the action of the stator magnetisation windings opposes the counterpart reluctance braking effect as the poles separate.

17. A motor-generator according to claim 16, wherein the electric current source connected to a stator magnetising winding of a first stator pole comprises, at least partially, the electrical pulses induced in the stator magnetising winding of a different second stator pole, the stator pole set configuration in relation to the rotor pole set configuration being such that the first stator pole is coming into register with a rotor pole as the second stator pole separates from its in-register position with a rotor pole.

Amendments to the claims have been filed as follows 1. An electrodynamic motor-generator machine comprising a stator configured to provide a set of stator poles, a corresponding set of magnetising windings mounted on the stator pole set, a rotor having two sections each of which has a set of salient pole pieces, the rotor sections being axially spaced along the axis of rotation of the rotor, rotor magnetisation means disposed between the two rotor sections arranged to produce a unidirectional magnetic field which magnetically polarises the rotor poles, whereby the pole faces of one rotor section all have a north polarity and the pole faces of the other rotor section all have a south polarity and electric circuit connections between an electric current source and the stator magnetising windings arranged to regulate the operation of the machine by admitting current pulses for a duration determined according to the angular position of the rotor, which pulses have a direction tending to oppose the polarisation induced in the stator by the rotor polarisation as stator and rotor poles separate from an in-register position, whereby the action of the rotor magnetisation means provides a reluctance motor drive force to bring stator and rotor poles into register and the action of the stator magnetisation windings opposes the counterpart reluctance braking effect as the poles separate, the machine being characterised in that the stator comprises separate ferromagnetic bridging members mounted parallel with the rotor axis, the ends of which constitute stator poles and the core sections of which provide closure paths operative when the stator and rotor poles are in register to confine magnetic flux developed by the rotor magnetisation means to a stator flux path of restricted cross-section disposed anti-parallel with the unidirectional magnetic field polarisation axis of the rotor magnetising means 2. A motor-generator according to claim 1, wherein the circuit connecting the electric current source and the stator magnetising windings is designed to deliver current pulses which are of sufficient strength and duration to provide demagnetisation of the stator poles as the stator and rotor poles separate from an in-register position.

3. A motor-generator according to claim 1, wherein the circuit connecting the electric current source and the stator magnetising windings is designed to deliver current pulses which are of sufficient strength and duration to provide a reversal of magnetic flux direction in the stator poles as the stator and rotor poles separate from an in-register position, whereby to draw on power supplied from the electric current source to provide additional forward drive torque.
4. A motor-generator according to claim 1, wherein the electric current source connected to a stator magnetising winding of a first stator pole comprises, at least partially, the electrical pulses induced in the stator magnetising winding of a different second stator pole, the stator pole set configuration in relation to the rotor pole set configuration being such that the first stator pole is coming into register with a rotor pole as the second stator pole separates from its in-register position with a rotor pole.
5. A motor-generator according to claim 1, wherein the number of poles in a set of stator poles is different from the number of rotor poles in each rotor section.
6. A motor-generator according to claim 1, wherein the stator configuration provides pole pieces which are common to both rotor sections in the sense that when stator and rotor poles are in-register the stator pole pieces constitute bridging members for magnetic flux closure in a magnetic circuit including that of the rotor magnetisation means disposed between the two rotor sections.
7. A motor-generator according to claim 6, wherein the number of poles in a set of stator poles and the number of rotor poles in each section do not share a common integer factor and the number of rotor poles in one rotor section is the same as that in the other rotor section.

**SELF-SUSTAINING ELECTRIC POWER GENERATOR UTILISING ELECTRONS
OF LOW INERTIAL MASS TO MAGNIFY INDUCTIVE ENERGY**

This patent application shows a very neat, self-powered electrical generator with a theoretical output of anything up to a COP of 59 when using cadmium selenide. The discussion of the theoretical aspects of the design includes a large amount of historical information and it covers the origin of the "law" of Conservation of Energy which, in spite of being incorrect, has been for decades, a major obstacle to the scientific development of free-energy devices.

Filed: 6th March 2006

Assignee: Levitronics, Inc.

Provisional application No. 60/697,729 filed on 8th July 2005

ABSTRACT

Electrical oscillations in a metallic "sending coil" radiate inductive photons toward one or more "energy-magnifying coils" comprised of a photoconductor or doped semiconductor coating a metallic conductor, or comprised of a superconductor. Electrons of low inertial mass in the energy-magnifying coil(s) receive from the sending coil, a transverse force having no in-line backforce, which exempts this force from the energy-conservation rule. The low-mass electrons in the energy-magnifying coil(s) receive increased acceleration proportional to normal electron mass divided by the lesser mass. Secondarily radiated inductive-photon energy is magnified proportionally to the electrons' greater acceleration, squared, e.g., the inductive-energy-magnification factor of CdSe photoelectrons with 0.13 x normal electron mass is 59 times. Magnified inductive-photon energy from the energy-magnifying coil(s) induces oscillating electric energy in one or more metallic "output coil(s)". The electric energy output exceeds the energy input if more of the magnified photon induction energy is directed toward the output coil(s) than is directed as a counter force to the sending coil. After an external energy source initiates the oscillations, feedback from the generated surplus energy makes the device a self-sustaining generator of electric power for useful purposes.

CROSS REFERENCE TO RELATED APPLICATION

This application corresponds to, and claims the benefit under 35 U.S.C. 119(e), of U.S. provisional application No. 60/697,729, filed on 8th July 2005, incorporated herein by reference in its entirety.

FIELD

This disclosure introduces a technical field in which practical electrical energy is created in accordance with the overlooked exception to the energy-conservation rule that Herman von Helmholtz described in his 1847 doctrine on energy conservation: "If . . . bodies possess forces which depend upon time and velocity, or which act in directions other than lines which unite each pair of material points, . . . then combinations of such bodies are possible in which force may be either lost or gained as infinitum". A transverse inductive force qualifies for Helmholtz's ad infinitum rule, but this force is not sufficient of itself to cause a greater energy output than input when applied to electrons of normal mass due to their unique charge-to-mass ratio. However, the increased acceleration of conduction electrons of less-than-normal inertial mass, as occurs in photoconductors, doped semiconductors, and superconductors, is proportional to the normal electron mass divided by the low electron mass, and the magnification of harnessable inductive energy is proportional to the square of the greater relative acceleration.

BACKGROUND

Magnetic force also satisfies Helmholtz's exemption to the energy-conservation rule because magnetic force is transverse to the force that causes it, and magnetic force is determined by the "relative velocity" (i.e. perpendicular to the connecting line) between electric charges. Magnification of magnetic force and energy was demonstrated by E. Leimer (1915) in the coil of a speaker phone and in the coil of a galvanometer when he irradiated a radio antenna-wire with radium. A 10 milligram, linear radium source produced a measured 2.6 fold increase in electrical current in the antenna wire in comparing inaudible radio reception without radium to audible reception with radium. This represented a $(2.6)^2 = 7$ times increase in electrical energy flowing through the

respective wire coils. The possibility of this enhanced reception being attributed to a person's body holding the unit of radium to the wire was eliminated by Leimer's additional observation that whenever the orientation of the small radium unit was changed to approximately 30 degrees relative to the wire, the energy enhancement ceased.

Applicant has deduced that Leimer's energy magnification was most likely due to low-mass electrons that were liberated and made conductive in the antenna by alpha radiation, which allowed these special electrons to be given a greater than normal acceleration by the received radio broadcast photons. Applicant has further deduced that such low-mass electrons must have originated in a thin-film coating of cupric oxide (CuO) on the antenna wire. CuO is a dull black polycrystalline semiconducting compound that develops in situ on copper and bronze wire in the course of annealing the wire in the presence of air. Such CuO coatings have been observed by Applicant on historical laboratory wire at the Science Museum at Oxford University, U.K. and on copper house wire of that era in the U.S., indicating that CuO coatings were commonplace. In later years, annealing has taken place under conditions that prevent most oxidation. This is followed by acid treatment to remove any remaining oxides, leaving shiny wire.

The same year that the English translation of Leimer's paper appeared in *Scientific American*, 16-year old Alfred M. Hubbard of Seattle, Washington, reportedly invented a fuelless generator, which he later admitted, employed radium. Applicant interprets this as implying that Leimer's energy-magnification was utilised by Hubbard with feedback to make it self-sustaining. Three years later, Hubbard publicly demonstrated a relatively advanced fuelless generator that illuminated a 20-watt incandescent bulb (Anon. 1919a). A reputable physics professor from Seattle College, who was intimately familiar with Hubbard's device (but not at liberty to disclose its construction details), vouched for the integrity of the fuelless generator and declared that it was not a storage device, but he did not know why it worked (Anon. 1919b). Because Hubbard initially had no financial means of his own, it is likely that the professor had provided Hubbard with the use of the expensive radium initially and thereby witnessed the inventing process in his own laboratory.

Newspaper photos (Anon. 1920a) of a more impressive demonstration of Hubbard's fuelless generator, show a device described as 14 inches (36 cm) long and 11 inches (28 cm) in diameter, connected by four heavy electrical cables to a 35 horsepower (26 kW) electric motor. The motor reportedly propelled an 18-foot open launch around a lake at a speed of 8 to 10 knots (Anon. 1920b). The event was witnessed by a cautious news reporter who claims to have checked thoroughly for any wires that might have been connected to hidden batteries, by lifting the device and motor from the boat. Radioactive-decay energy can be eliminated as the main power source because about 10^8 times more radium than the entire world's supply would have been needed to equal Hubbard's reported electric energy output of 330 amperes and 124 volts.

Lester J. Hendershott of Pittsburgh, Pa., reportedly demonstrated a fuelless generator in 1928 that was claimed by Hubbard to be a copy of his own device (1928h). The president of Stout Air services, William B. Stout, who also designed the Ford Trimotor aeroplane, reported (1928b): "The demonstration was very impressive. It was actually uncanny.... The small model appeared to operate exactly as Hendershot explained it did". Also reportedly attesting to the operability of Hendershott's fuelless generator were Colonel Charles A. Lindbergh and Major Thomas Lanphier of the U.S. Air Corps (1928a, et seq.), and Lanphier's troops reportedly assembled a working model of his device.

To the Applicant's best knowledge, the only depiction that was made public of the interior components of any of these reported generators consists of a sketchy drawing (Bermann 1928h) of Hubbard's apparatus similar in size to the device shown in his 1919 demonstration. It depicts a complex set of parallel coils measuring 6 inches (15 cm) in length and 4.5 inches (11.4 cm) in overall diameter. Four leads of insulated wire, with the insulation peeled back, are shown coming out of the end of the device. What those four wires were connected to internally was not shown. Hubbard's description of the internal arrangement of coils in the device generally matches the drawing (Anon. 1920a): "It is made up of a group of eight electromagnets, each with primary and secondary windings of copper wire, which are arranged around a large steel core. The core likewise has a single winding. About the entire group of cells is a secondary winding". Nothing was reported or depicted about how components functioned with each other, or how much radium was used and where the radium was positioned. The only connectors visible on the drawing were between the outer windings of the eight electromagnet coils. These connectors show that the direction of the windings alternated between clockwise and counterclockwise on adjacent coils, so that the polarity of each electromagnet would have been opposite to that of its adjacent neighbours.

If the Hubbard and Hendershot devices actually operated as reported, they apparently never attained acceptance or commercial success. Assuming the devices actually worked, their lack of success may have been largely financially or supply based, or both, compounded with scepticism from believers in the energy-conservation doctrine. How much radium was employed by Hubbard in his larger generator can only be guessed at, but assuming a typical laboratory radium needle containing 10 milligrams of radium was used, that amount would have cost \$900 in 1920, dropping to \$500 in 1929. That much radium in a fuelless generator would have cost as much as an inexpensive automobile in the 1920s. Possibly much more radium was used than 10 milligrams.

In 1922, when the Radium Company of America of Pittsburgh, Pa., reportedly discontinued its work with Hubbard on his invention (1928h), the entire world's supply of radium was only about 250 grams. With the extreme

assumption that only 1 milligram of radium was needed per generator, less than 10% of a single year's production of autos in the US in the mid-1920s could have been supplied with such generators. Apparently Hendershott had tried to revive the technology by showing that the fuelless generator could extend the range of air flight indefinitely, but his technology never attracted a sponsor from any private, public or philanthropic entity.

U.S. Pat. No. 4,835,433 to Brown, superficially resembles the drawing of Hubbard's device. Brown's device appears to have the same number and essentially the same general arrangement of wire coils as Hubbard's generator, as nearly as can be understood from the newspaper articles depicting that device. Apparently, no information concerning either the Hubbard or Hendershot devices was considered during the prosecution of the '433 patent. Brown discusses the conversion of energy of radioactive decay products, principally alpha emissions, to electrical energy by amplifying electrical oscillations in a high-Q L-C circuit irradiated by radioactive materials. "During the absorption process, each alpha particle will collide with one or more atoms in the conductor, knocking electrons from their orbits and imparting some kinetic energy to the electrons in the conductor, thereby increasing its conductivity". (Col. 3, Line 68 to Col. 4, line 5). No claim was made by Brown, that the device employed a semiconductor or photoconductor that could have provided low-mass electrons for energy magnification.

Brown claimed an output of 23 amps at 400 volts, which is vastly greater than all the decay energy represented by his reported radioactive content of 1 milligram of radium that was surrounded by weakly radioactive uranium rods and thorium powder. Powered thorium is highly pyrophoric, so it is typically sealed in a nitrogen atmosphere to prevent spontaneous combustion. In his device, Brown reportedly confined the thorium in cardboard without any mention of sealing out air. This condition would have invited a meltdown that could have been interpreted as massive out-of-control electrical production.

To the best of the Applicant's knowledge, no person other than the Applicant has ever indicated that the presence of cupric oxide on their wires could have provided energy magnification. If Hubbard's device actually did work, certain characteristics of its design are unexplainable by the Applicant, namely the use of four rather than two large electrical cables to connect his device to an electrical motor, and the use of alternating polarity instead of single-direction polarity in the orientation of the multiple coils surrounding a central coil. Applicant therefore believes that the specification herein sets forth original configurations of electrical-energy generators that have no known precedent.

SUMMARY

To address the needs for electrical generators which are capable of self-generating substantial amounts of electrical power in various environments, and which are portable as well as stationary, apparatus and methods are provided for magnifying an electrical input, and (with feedback) for generating usable electrical power indefinitely without fuel or other external energy source, except for starting. The apparatus utilises electrons of low effective mass, which receive greater acceleration than normal electrons in an amount that is inversely proportional to the effective mass. Applicant has determined that effective mass is the same as the electron's true inertial mass. The photon energy that is radiated when an electron is accelerated is proportional to the square of the acceleration, so the increase in radiated photon energy from an accelerated low-mass electron over the energy from a normal electron is equal to the inverse square of the effective mass, e.g. the calculated energy magnification provided by photoconducting electrons in cadmium selenide, with an electron effective mass of 0.13, is 59 times. The use of a transverse force, that lacks a direct back-force, to accelerate low-mass electrons in an oscillating manner, circumvents any equal-and-opposite force that would invoke the application of the energy-conservation law of kinetics and thermodynamics.

The various embodiments of the apparatus, which are configured either to continuously magnify an input of oscillating electric energy, or to serve as a self-sustaining electric generator, employ three principal components:

At least one sending coil

At least one energy-magnification coil, comprising a material that produces , in a "condition" low-mass electrons, and

At least one output coil.

It is desirable that the apparatus also includes a means for establishing the condition with respect to the energy-magnifying coil(s). Except where otherwise indicated in the remainder of this text, where the number of coils of a particular type is referred to in the singular, it will be understood that a plurality of coils of the respective type can alternatively be utilised.

Electrical oscillation in the sending coil, which is comprised of a metallic conductor, causes radiation of inductive photons from the sending coil. The energy-magnifying coil is situated in a position relative to the sending coil so as to receive inductive photons from the sending coil. The inductive photons radiating from electrical oscillations in the sending coil, convey a transverse force to the low-mass electrons in the energy-magnification coil with no

back-force on the sending coil. The greater-than-normal accelerations which are produced in the low-mass electrons of the energy-magnifying coil, produce greater irradiation energy of inductive photons than normal.

The output coil is positioned so as to receive the magnified inductive-photon energy from the energy-magnifying coil. The inductive-photon energy received by the output coil, which is comprised of a metallic conductor, is converted into an oscillating electrical current of normal electrons. In order for the electrical output to exceed the electrical input, the output coil is situated in such a manner that it receives more of the magnified inductive-photon energy than that which is directed back against the sending coil to act as a back-force. This "energy leverage" causes the electrical energy output to exceed the electrical energy input.

By way of example, the energy-magnifying coil can comprise a superconducting material, wherein the "condition" is a temperature (e.g. a cryogenic temperature) at which the superconducting material exhibits superconducting behaviour characterised by production of low-mass electrons.

By way of another example, the energy-magnifying coil can comprise a photoconductive material, wherein the "condition" is a situation in which the photoconductive material is illuminated by a wavelength of photon radiation sufficient to cause the photoconductive material of the energy-magnifying coil to produce conduction electrons having low effective mass. In this latter example, the means for establishing the condition can comprise a photoconductor exciter (e.g. one or more LEDs) situated and configured to illuminate the photoconductive material of the energy-magnifying coil with the wavelength of photon radiation.

By way of yet another example, the "condition" is the presence of a particular dopant in a semiconductor that provides a low-mass electron as a charge carrier. Also, by way of example, the energy-magnifying coil can comprise a semiconductive element or compound that has been doped with a particular element or compound that makes it conductive of low-mass electrons without illumination by photon radiation other than by ambient photons.

Various apparatus embodiments comprise different respective numbers and arrangements of the principal components. The various embodiments additionally can comprise one or more of circuitry, energisers, shielding and other components to fulfill the object of providing a self-sustaining source of electrical power for useful purposes.

Also provided, are methods for generating an electrical current. In an embodiment of such a method, a first coil is energised with an electrical oscillation sufficient to cause the first coil to radiate inductive photons. At least some of the radiated inductive photons from the first coil are received by a second coil, called "the energy-magnifying coil", comprising a material that produces low-mass electrons. The received inductive photons impart respective transverse forces to the low-mass electrons that cause the low-mass electrons to experience accelerations in the material which are greater than accelerations that otherwise would be experienced by normal free electrons experiencing the transverse forces.

Conduction of the accelerated low-mass electrons in the second coil, causes the second coil to produce a magnified inductive force. The magnified inductive force is received by a third coil which causes the third coil to produce an oscillating electrical output of normal conduction electrons which has greater energy than the initial oscillation. A portion of the oscillating electrical output is directed as feed-back from the third coil to the sending coil, so as to provide the electrical oscillation to the sending coil. This portion of the oscillating electrical current directed to the sending coil, desirably is sufficient to cause self-sustaining generation of inductive photons by the first coil without the need for any external energy source. The surplus oscillating electrical output from the third coil can be directed to a work loop.

The method can further comprise the step of starting the energisation of the first coil to commence generation of the oscillating electrical output. This "starting" step can comprise momentarily exposing the first coil to an external oscillating inductive force or for example, to an external magnetic force which initiates an electrical pulse.

The foregoing and additional features and advantages of the invention will be more readily apparent from the following detailed description, which proceeds with reference to the accompanying drawings.

BRIEF DESCRIPTION OF THE DRAWINGS

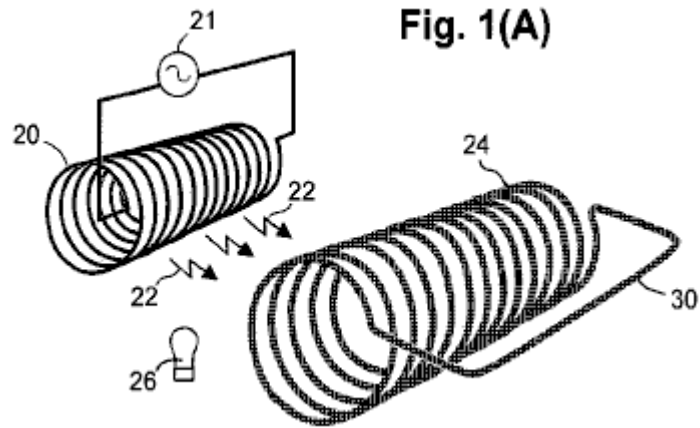

Fig.1A is a perspective view schematically depicting a sending coil in relationship to an energy-magnifying coil such that inductive photons from the sending coil, propagate to the energy-magnifying coil.

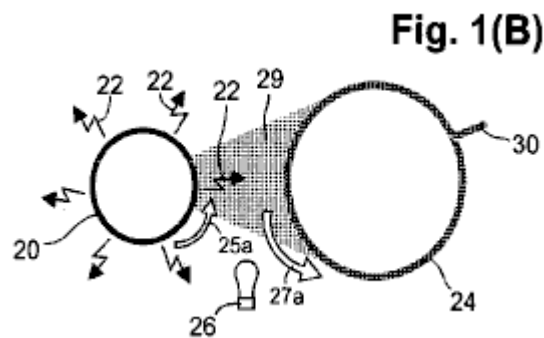

Fig.1B is a schematic end-view of the sending coil and energy-magnifying coil of **Fig.1A**, further depicting radiation of inductive photons from the sending coil and the respective directions of electron flow in the coils.

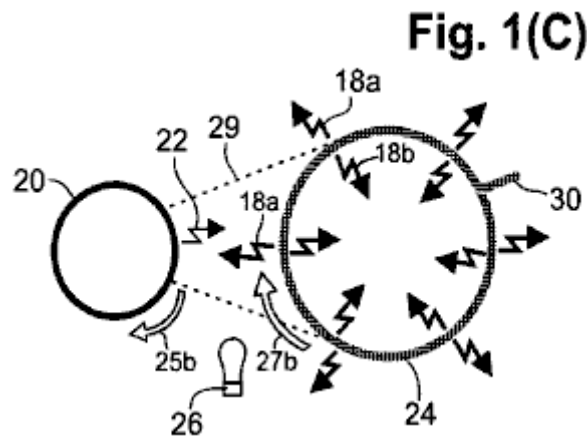

Fig.1C is a schematic end-view of the sending coil and energy-magnifying coil of **Fig.1A**, further depicting the production of inwardly-radiating and outwardly-radiating magnified inductive photons from the energy-magnifying coil.

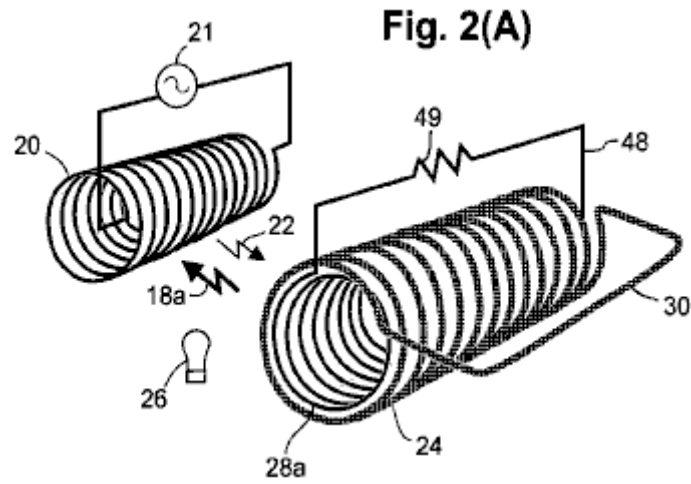

Fig.2A is a perspective view schematically showing an internal output coil, coaxially nested inside the energy-magnifying coil to allow efficient induction of the internal output coil by the energy-magnifying coil, wherein the induction current established in the internal output coil is used to power a load connected across the internal output coil.

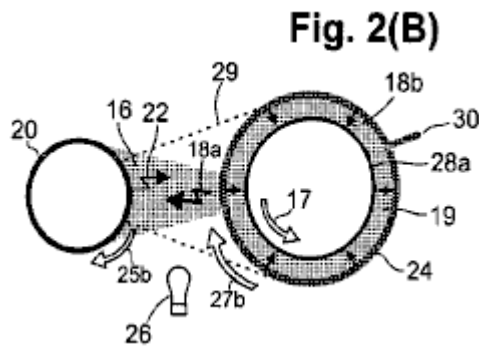

Fig.2B is a schematic end-view of the coils shown in **Fig.2A**, further depicting the greater amount of magnified inductive-photon radiation that is received by the external output coil in comparison to the lesser amount that is directed toward the sending coil to act as a back-force.

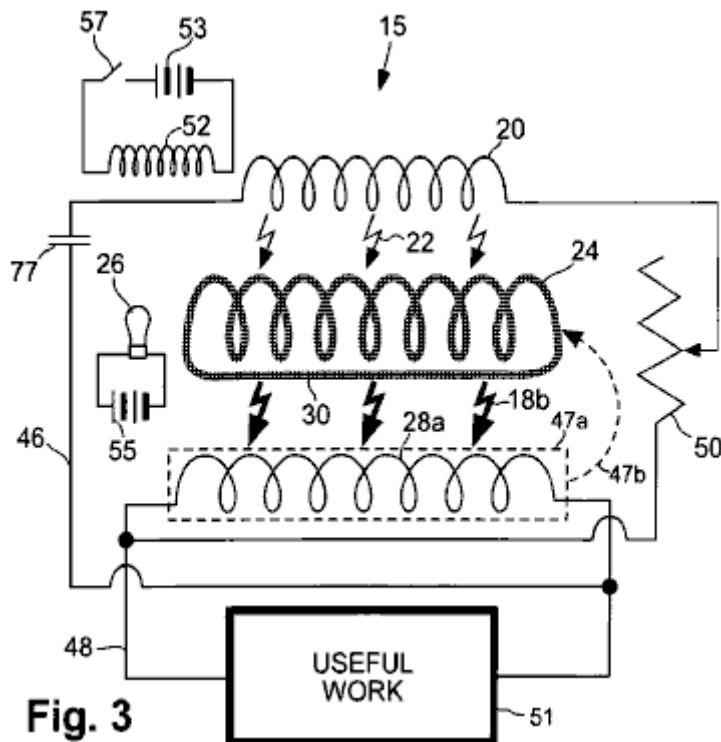

Fig. 3

Fig.3 is an electrical schematic diagram of a representative embodiment of a generating apparatus.

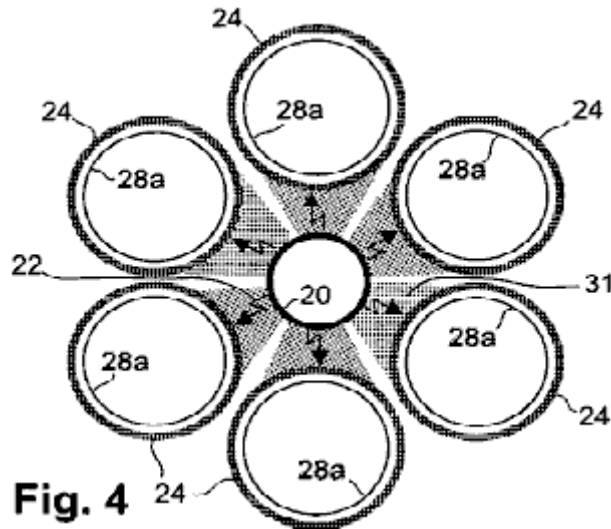

Fig.4 is a schematic end-view of a representative embodiment, comprising a centrally disposed sending coil surrounded by six energy-magnifying coils, each having an axis which is substantially parallel to the axis of the sending coil. A respective internal output coil is coaxially nested inside each energy-magnifying coil, and the energy-magnifying coils are arranged so as to capture substantially all the inductive photons radiating from the sending coil.

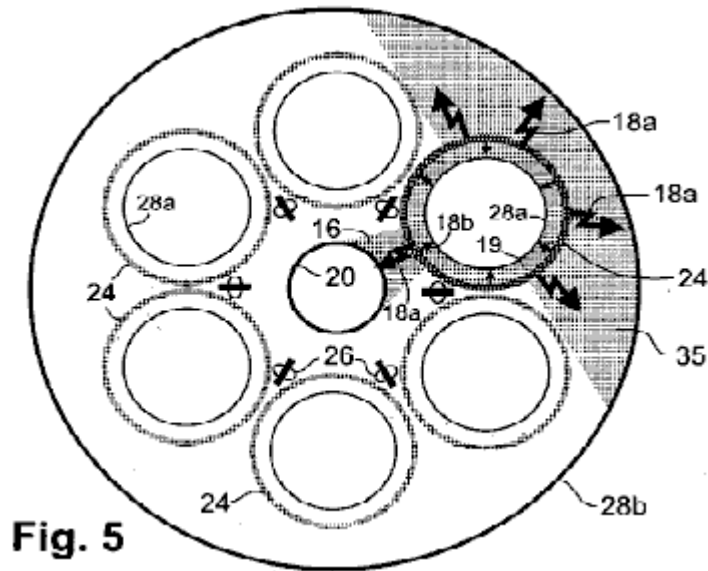

Fig.5 is a schematic end-view of the embodiment of Fig.4, further including an external output coil situated coaxially with the sending coil and configured to surround all six energy-magnifying coils so as to capture outwardly-radiating inductive photons from the energy-magnifying coils. Also depicted is the greater amount of magnified inductive-photon radiation that is received by the internal output coils and the external output coil in comparison to the lesser amount of inductive-photon radiation that is directed towards the sending coil to act as a back-force. Also shown are the arrays of LEDs used for exciting the energy-magnifying coils to become photoconductive.

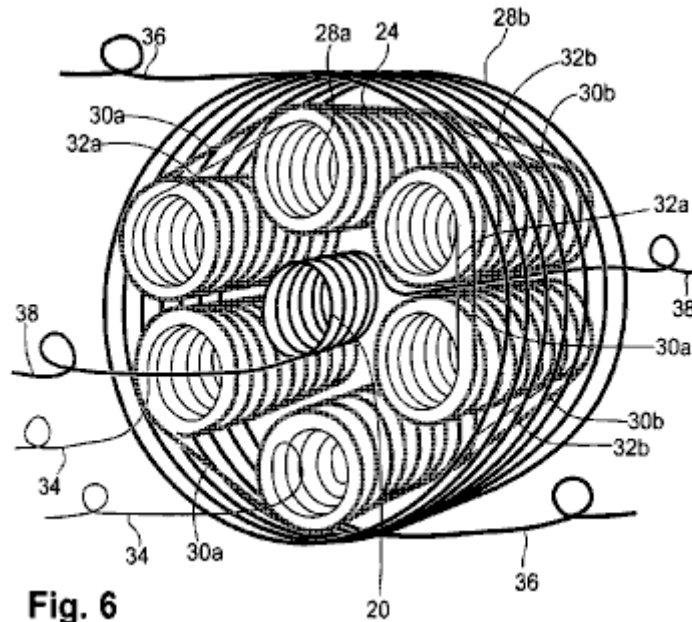

Fig. 6

Fig.6 is a perspective view of the embodiment of **Fig.4** and **Fig.5** but further depicting respective inter-coil connections for the energy-magnifying and internal output coils, as well as respective leads for the sending coil, internal output coils and external output coil.

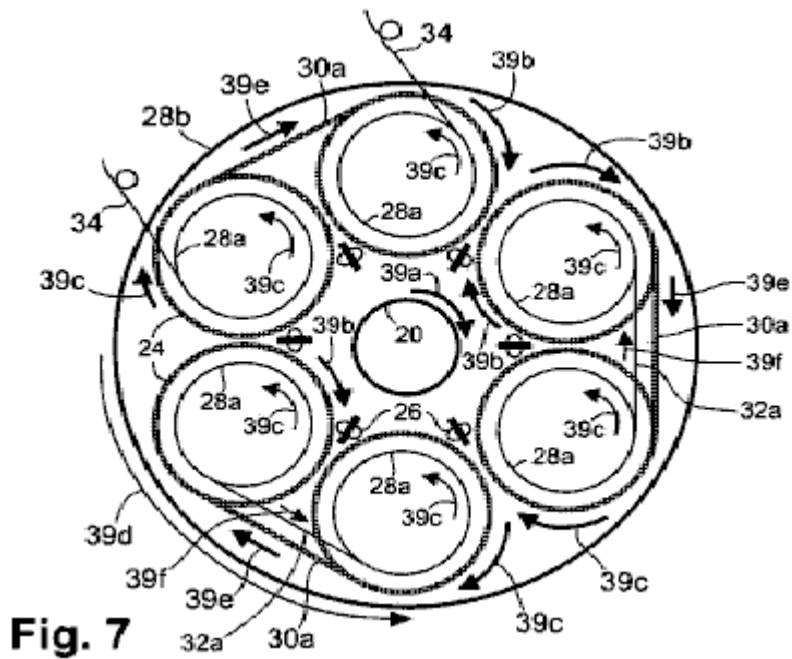

Fig. 7

Fig.7 is a head-end view schematically depicting exemplary current-flow directions in the sending coil, energy-magnifying coils, internal output coils, and external output coils, as well as in the various inter-coil connections of the embodiment of **Fig.4**.

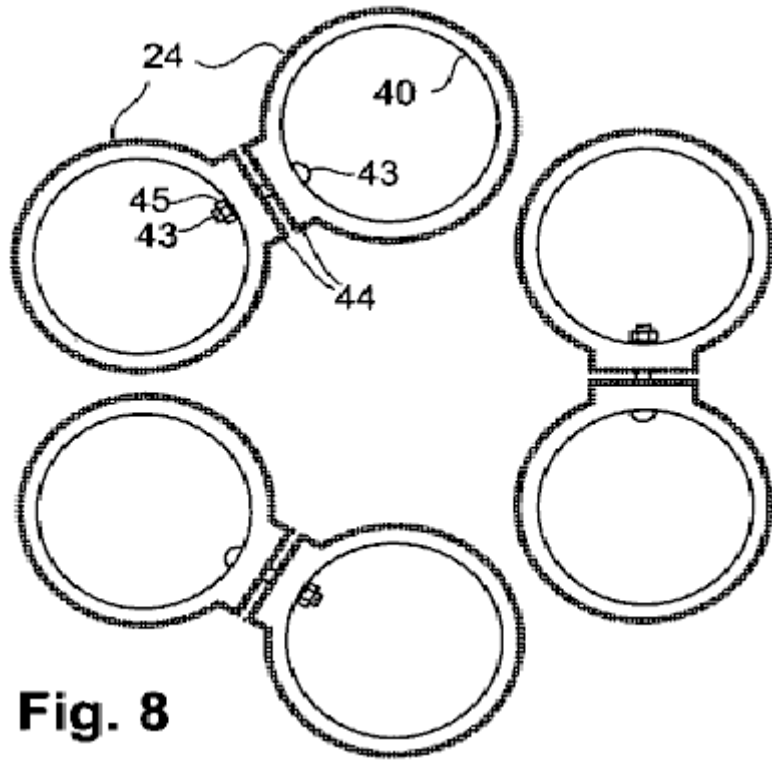

Fig. 8

Fig.8 is a schematic end-view showing an embodiment of the manner in which inter-coil connections can be made between adjacent energy-magnifying coils.

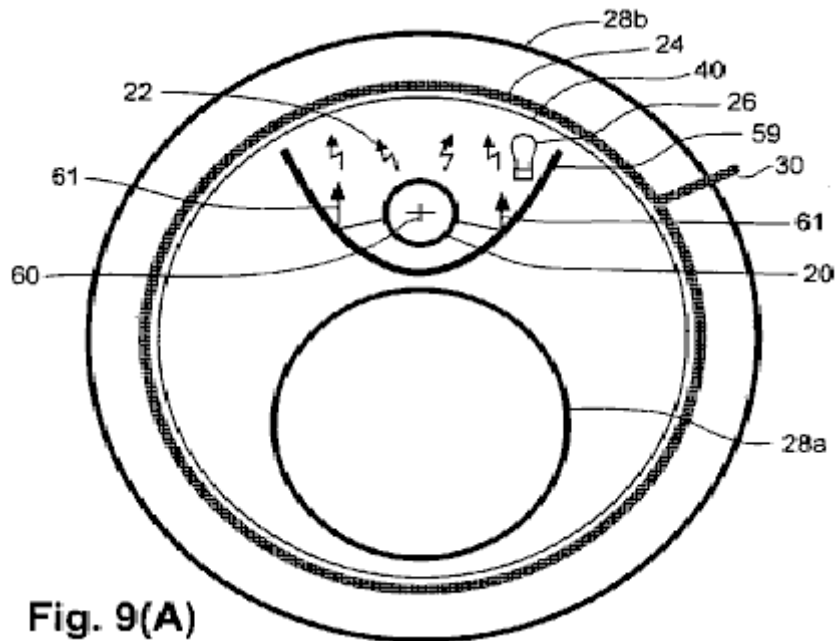

Fig. 9(A)

Fig.9A is a schematic end-view depicting the coil configuration of an embodiment in which a sending coil and an internal output coil are nested inside an energy-magnifying coil, which in turn is nested inside an exterior output coil. A metallic separator, having a substantially parabolic shape, and being situated between the sending coil and the internal output coil, reflects some of the otherwise unused inductive-photon radiation to maximise the effective radiation received by the energy-magnifying coil. Also, the metallic shield prevents the internal output coil from receiving radiation sent from the sending coil.

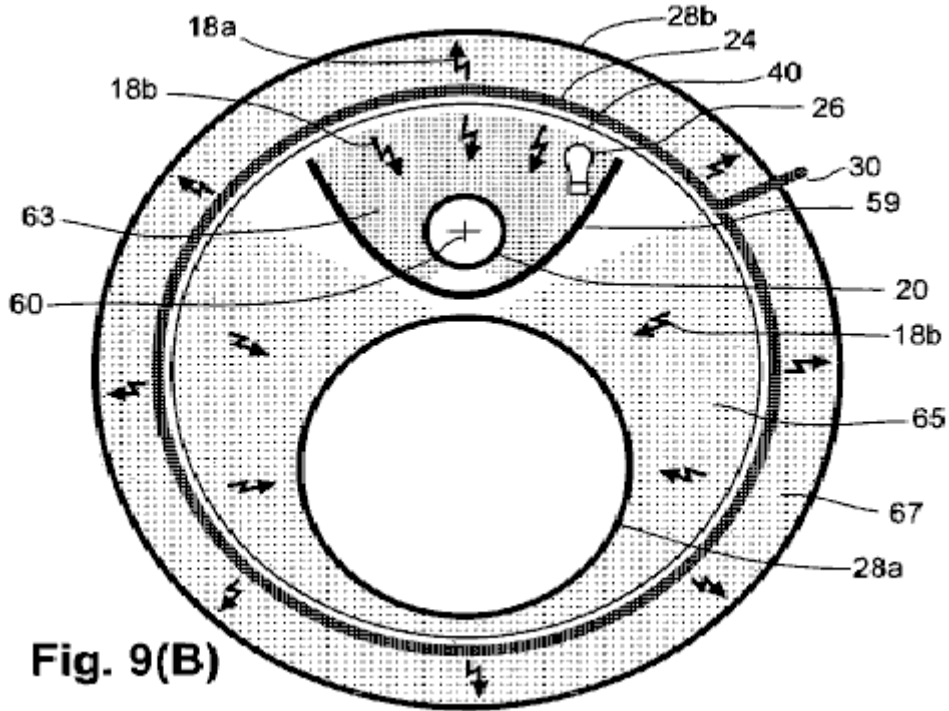

Fig. 9(B)

Fig.9B is a schematic end-view of the coil configuration of **Fig.9A**, further depicting the metallic separator acting as a shield to restrict the back-force radiation reaching the sending coil while allowing the internal output coil to receive a substantial portion of the magnified radiation from the energy-magnifying coil. Also depicted is the greater amount of magnified inductive-photon radiation that is received by the internal output coil and the external output coil in comparison to the lesser amount that is received by the sending coil to act as a back-force.

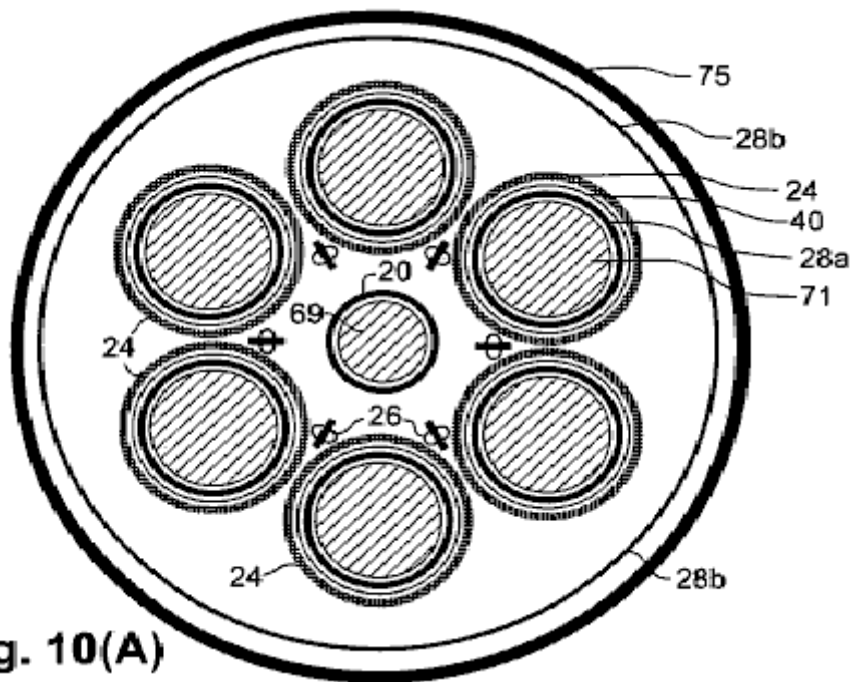

Fig. 10(A)

Fig10A is a schematic end-view depicting the coil configuration of yet another embodiment that is similar in some respects to the embodiment of **Fig.4**, but also including respective ferromagnetic cores inside the sending coil and internal output coils. Also depicted is a metallic shield surrounding the entire apparatus.



Fig. 10(B)

Fig.10B is a schematic end-view of a sending coil of yet another embodiment in which a ferromagnetic sleeve is disposed coaxially around the sending coil.

DETAILED DESCRIPTION

General Technical Considerations

An understanding of how “infinite energy” mistakenly came to be rejected by the scientific community, clarifies the basis of this invention. The electrodynamic function described in the embodiments described below, conforms to Helmholtz’s alternate energy rule, which states that a force which is not in line with it’s causative force “may be lost or gained ad infinitum”. This rule was included in “Uber die Erhaltung der Kraft” (“On the Conservation of Force”) that Hermann Helmholtz delivered to the Physical Society of Berlin in 1847. But, Helmholtz mistakenly believed that “all actions in nature are reducible to forces of attraction and repulsion, the intensity of the forces depending solely upon the distances between the points involved so it is impossible to obtain an unlimited amount of force capable of doing work as the result of any combination whatsoever of natural objects”.

Helmholtz refused to accept the idea that magnetic energy qualifies for ad infinitum status despite the fact that Ampere’s (1820) magnetic force on parallel straight conductors is obviously transverse to the direction of the electric currents rather than being in line with the currents. He omitted mention that the magnetic force in Ampere’s (1825) important invention, the solenoidal electromagnet, is caused by currents in the loops of his coils, which are transverse to the direction of magnetic force. Also, he failed to mention that Ampere considered the magnetic force of a permanent magnet to be caused by minute transverse circular currents, which are now recognised as electrons that spin and orbit transversely.

Helmholtz, who was educated as a military medical doctor without any formal study of physics, relied instead on an obsolete metaphysical explanation of magnetic force: “Magnetic attraction may be deduced completely from the assumption of two fluids which attract or repel in the inverse ratio of the square of their distance....It is known that the external effects of a magnet can always be represented by a certain distribution of the magnetic fluids on its surface”. Without departing from this belief in magnetic fluids, Helmholtz cited Wilhelm Weber’s (1846) similarly wrong interpretation that magnetic and inductive forces are directed in the same line as that between the moving electric charges which cause the forces.

Weber had thought that he could unify Coulombic, magnetic, and inductive forces in a single, simple equation, but Weber’s flawed magnetic-force term leads to the absurd conclusion that a steady current in a straight wire induces a steady electric current in a parallel wire. Also, a changing current does not induce an electromotive force in line with the current, as Weber’s equation showed. The induced force is offset instead, which becomes more apparent the further that two nested, coaxial coils are separated. What appears to be a directly opposing back-force is actually a reciprocal inductive force.

Helmholtz’s assertion that the total sum of the energy in the universe is a fixed amount that is immutable in quantity from eternity to eternity appealed to his young friends. But, the elder scientists of the Physical Society of Berlin declared his paper to be “fantastical speculation” and a “hazardous leap into very speculative metaphysics”, so it was rejected for publication in *Annalen der Physik*. Rather than accept this rejection constructively, Helmholtz found a printer willing to help him self-publish his work. Helmholtz headed the publication with a statement that his paper had been read before the Society, but he disingenuously withheld mention of its outright rejection. Unwary readers have since received the wrong impression that his universal energy-conservation rule had received the Society’s endorsement rather than its censure.

Helmholtz (1862, 1863) publicised his concept thus: “We have been led up to a universal natural law, which ... expresses a perfectly general and particularly characteristic property of all natural forces, and which ... is to be placed by the side of the laws of the unalterability of mass and the unalterability of the chemical elements”. Helmholtz (1881) declared that any force that did not conserve energy would be “in contradiction to Newton’s axiom, which established the equality of action and reaction for all natural forces” (sic). With this deceitful misrepresentation of Newton’s strictly mechanical principle, Helmholtz had craftily succeeded in commuting the profound respect for Newton’s laws to his unscientific doctrine. Subsequently, the Grand Cross was conferred on Helmholtz by the kings of Sweden and Italy and the President of the French Republic, and he was welcomed by the German Emperor into nobility with the title of “von” added to his name. These prestigious awards made his doctrine virtually unassailable in the scientific community.

Ampere’s principle of transverse magnetic attraction and repulsion between electric currents had been made into an equation for the magnetic force between moving electric charges by Carl Fredrick Gauss (written in 1835, published posthumously in 1865). The critical part of the Gauss equation shows, and modern physics texts agree, that magnetic force is transverse to the force that imparts a relative velocity (i.e. perpendicular to a connecting line) between charges. Lacking a direct back-force, a transverse magnetic force can produce a greater force than the force that causes it.

The only physicist to recognise in print, the profound significance of the work of Gauss, was James Clerk Maxwell (1873), who stated "(If Gauss's formula is correct), energy might be generated indefinitely in a finite system by physical means". Prepossessed with Helmholtz's "law", Maxwell chose not to believe Gauss's transverse magnetic-force equation and accepted Wilhelm Weber's (1846) erroneous in-line formula instead. Maxwell even admitted knowing of Gauss's (1845) rebuke of Weber for his mistaken direction of magnetic force as "a complete overthrow of Ampere's fundamental formula and the adoption of essential a different one".

In 1893, the critical part of Ampere's formula for magnetic force, which Weber and Maxwell rejected, and which Helmholtz had replaced with his contrary metaphysical explanation, was proposed for the basis for the international measure of electric current, the Ampere (or amp), to be defined in terms of the transverse magnetic force which the current produces. But Helmholtz's doctrine had become so impervious to facts that anyone who challenged this "law" faced defamation and ridicule.

The first recognition of unlimited energy came from Sir Joseph Larmor who reported in 1897, "A single ion e, describing an elliptic orbit under an attraction to a fixed centre ... must rapidly lose its energy by radiation ... but in the cases of steady motion, it is just this amount that is needed to maintain the permanency of motion in the aether". Apparently to mollify critics of his heretical concept, Larmor offered a half-hearted recantation in 1900: "The energy of orbital groups ... would be through time, sensibly dissipated by radiation, so that such groups could not be permanent".

In 1911, Rutherford found that an atom resembles a small solar system with negative ions moving like planets around a small, positively charged nucleus. These endlessly orbiting electrons were a source of the perpetual radiation that had aptly been described by Larmor, and these orbiting electrons were also Planck's (1911) "harmonic oscillators" which he used to explain Zero-point Energy (ZPE). ZPE was shown by the fact that helium remains liquid under atmospheric pressure at absolute zero, so that helium must be pressurised to become solid at that temperature. Planck believed that harmonic oscillators derived "dark energy" from the aether to sustain their oscillations, thereby admitting that an infinite source of energy exists. However, he assigned an occult origin to this infinite energy, rather than a conventional source that had not met with Helmholtz's approval.

Niels Bohr (1924) was bothered by the notion that radiation from an orbiting electron would quickly drain its energy so that the electron should spiral into the nucleus. Whittaker (1951) states, "Bohr and associates abandoned the principle ... that an atom which is emitting or absorbing radiation must be losing or gaining energy. In its place, they introduced the notion of virtual radiation, which was propagated in ... waves but which does not transmit energy or momentum". Subsequently, the entire scientific community dismissed Larmor radiation as a source of real energy because it failed to conform to Helmholtz's universally accepted doctrine.

Helmholtz's constraining idea that the vast amount of light and heat radiating from the many billions of stars in the universe can only come from previously stored energy, has led scientists to concur that fusion of pre-existing hydrogen to helium, supplies nearly all the energy that causes light and heat to radiate from the sun and other stars. If so, then the entire universe will become completely dark after the present hydrogen supply in stars is consumed in about 20 billion years. William A. Fowler (1965) believed that essentially all the hydrogen in the universe "emerged from the first few minutes of the early high-temperature, high-density stage of the expanding Universe, the so-called 'big bang' ..." Moreover, the background energy of the universe was thought by some to be "relic" radiation from the "Big Bang".

To accept the Big Bang idea that all the stars in the universe originated at the same time, it was necessary to disregard the fact that most stars are much younger or much older than the supposed age of the one-time event, which indicates that their energy must have come from a recurring source. The Big Bang is entirely dependent on the idea that the whole universe is expanding, which stemmed from the interpretation that Hubble's red-shift with distance from the light source, represents a Doppler shift of receding stars and galaxies. This expanding-universe interpretation was shattered by William G. Tifft (1976, 1977), who found that observed red-shifts are not spread randomly and smoothly over a range of values, as would be expected from the Doppler shifts of a vast number of receding stars and galaxies. Instead, the observed red-shifts all fall on evenly spaced, quantised values.

Moreover, Shpenkov and Kreidik (2002) determined that the radiation temperature corresponding to the fundamental period of the orbital electron motion in the hydrogen atom of 2.7289^0K matches the measured temperature of cosmic background radiation of 2.725^0K plus or minus 0.002^0K . This represents perpetual zero-level Larmor radiation from interstellar hydrogen atoms dispersed in the universe. So, Helmholtz's idea that "the energy in the universe is a fixed amount immutable in quantity from eternity to eternity" does not stand up to known facts.

The large aggregate quantity of heat-photons which is generated continually by Larmor radiation can account for the illumination of stars and for the enormous heat and pressure in active galactic centres. Based on the fact that photons exhibit momentum, photons must possess mass, because, as Newton explained, momentum is mass times velocity, which in this case is "c". Consequently, the creation of photons by induction or by Larmor radiation, also creates new mass. The conditions that Fowler was seeking for hydrogen nucleosynthesis, are apparently being supplied indefinitely in active galaxies and possibly in the sun and other stars above a certain size. This invention utilises a similar unlimited energy source.

Another principle that is important to this specification, is that the transfer of energy by electrical induction was found by the Applicant to work in the same manner as the transfer of energy by broadcast and reception of oscillating radio signals. A transverse force is communicated in both cases, the force declines similarly with distance, and the effects of shielding and reflection are identical. Since radio signals are communicated by photons, Applicant considers that inductive force is also communicated by photons. The radiation of newly formed inductive photons results when an accelerated charge experiences a change in direction of acceleration. Inductive radiation occurs when the acceleration of electric charges is reversed, as in Rontgen's bremsstrahlung, in Hertz's linear oscillator (plus all other radio-broadcasting antennas), and in coils which carry an alternating current.

In a similar case, when electric charges move in a curving motion due to a continually changing centripetal acceleration, inductive photons are radiated steadily. This includes the radiation from electrons orbiting atomic nuclei (Larmor radiation) and from conduction electrons flowing in a wire coil, whether the current is steady or not. Circularly produced inductive photons induce a circular motion (diamagnetism) in mobile electrons located near the axis of the electron's circular movement.

In both the reverse-acceleration and centripetal-acceleration cases, inductive photons convey a force to mobile electrons that is transverse to the photon's propagation path. As Lapp and Andrews (1954) reported, "Low-energy photons produce photoelectrons at right angles to their path ...". This same right-angle force without a direct back-force, applies as well, to all conduction electrons which are accelerated by low-energy photons. Hence, inductive energy qualifies for exemption from the energy-conservation law by Helmholtz's same ad infinitum principle which exempts magnetic energy.

The transverse force that inductively produced photons delivered to mobile electrons, is opposite in direction to the simultaneous movement of the primary charge which produces the radiation. This is shown by Faraday's induced current opposite to the inducing current and by the diamagnetically-induced circular motion which, in a rotational sense, is opposite to the circular electron motion in the coil producing it. An oscillating flow of electrons within a loop of a wire coil, induces a force on the conduction electrons which is in the opposite direction in adjacent loops of the same wire. This results in self-induction.

Important to this specification is the realisation that the energy transmitted by photons is kinetic rather than electromagnetic. Inductively radiated photons of low energy, light rays and X-rays cannot be deflected by an electric or magnetic field due to the photons' neutral charge. Neither do neutral photons carry an electric or magnetic field with them. Photon radiation is produced by a change in the acceleration of an electric charge, so only in special cases does it have an electrokinetic origin which involves a magnetic force. To honour these facts, Applicant uses the term "electrokinetic spectrum" in place of "electromagnetic spectrum".

Another principle which is important to this specification is the realisation that, although the charge on the electron has a constant value under all conditions, the mass of an electron is not a fixed, unchanging amount. All free electrons, as in cathode rays, have exactly the same amount of mass at sub-relativistic velocities. This is called "normal" mass and is denoted by m_e . Free electrons have a unique charge to mass ratio that makes the magnetic force resulting from a sub-relativistic velocity imparted to such an electron, exactly equal to the energy input with "normal" electrons.

Also, when a normal electron is given a sub-relativistic acceleration, the inductive force it produces is equal to the force it receives. The mass of highly conductive electrons of metals is apparently very close to normal, but any very slight inductive-energy gains would be masked by inefficiencies. The ubiquity of free electrons and the conduction electrons of metals has led to the view that electron mass is a never-varying figure that would allow the energy conservation law to apply to magnetic energy and inductive energy.

Accurate determinations of electron mass in solid materials have been made possible by cyclotron resonance, which is also called diamagnetic resonance. The diamagnetic force produced by the steady flow of electrons in a wire coil, induces the mobile electrons of a semiconductor to move in a circular orbit of indefinite radius but at a definite angular frequency. This frequency is only related to the inductive force and the mass of the electron. At the same time, a repulsive magnetic force is developed by the relative velocity between the electron flow in the coil and the conduction electrons, causing the mobile electrons of the semiconductor to move in a helical path away from the coil rather than in planar circles. Only two measurements are needed to determine the mass of such an electron: the cyclotron frequency which resonates with the frequency of the electron's circular motion, and the strength of the inductive force, which is determined by the current and dimensions of the coil. Since the co-produced magnetic field is related to the same parameters, its measurement serves as a surrogate for inductive force.

Because the measured mass of conduction electrons in semiconductors is less than normal, a complicated explanation has been adopted to defend the constancy of electron mass in order to support Helmholtz's energy doctrine. An extra force is supposedly received from the vibrational lattice-wave energy of the crystal (in what would have to be an act of self-refrigeration) to make normal-mass electrons move faster than expected around a circular path, thereby giving the appearance that the electron has less mass than normal. In this explanation, the electron is considered to be a smeared-out wave rather than a particle, which is contradicted by the billiard-ball-

like recoil of an electron when it is bumped by a quantum of radiation, as described by Arthur Crompton and Samuel Allison (1935).

The fallacy that borrowed energy can provide a boost in velocity to an electron, is more apparent in the case of linear motion. The effective-mass theory considers that the greater linear velocity is caused by a boost given to normal-mass electrons by a "longitudinal wave" imparted by an externally applied force in the same direction as the electron motion. Since this longitudinal wave is also considered to have a source in crystal-lattice vibrations, the effective-mass theory relies on a reversal of entropy in violation of the second Law of Thermodynamics.

No reasonable contribution of direct directional energy can be invoked from any source to impart abnormally great velocity to the conduction electrons in semiconductors. So, the operation of apparatus embodiments described herein, relies on electrons having particle properties and on electrons having less-than-normal inertial mass without invoking any special forces. This is supported by Brennan's (1999) statement that "the complicated problem of an electron moving within a crystal under the interaction of a periodic but complicated potential, can be reduced to that of a simple free particle, but with a modified mass". The term "effective" is herein considered redundant in referring to truly inertial mass, but "effective mass" still has relevance in referring to the net movement of orbital vacancies or "holes" in the opposite direction of low-mass electrons.

By $F = ma$, a low-mass electron receives greater acceleration and greater velocity from a given force than an electron of normal mass. The velocity and kinetic energy imparted to an electrically charged body by a force, are determined by the electric charge without regard to the body's mass. Having a smaller amount of mass, allows a body to attain a greater velocity with any given force. Hence, the magnetic force produced by the charge at this higher velocity will be greater than it would normally be for that same amount of force. This allows low-mass electrons to produce a magnetic force that is greater than the applied force.

Also, the amount of inductive radiation energy from accelerated electrons is related to an electron's charge without regard to its mass. The energy of inductive radiation increases with the square of the electron's acceleration according to Larmor's (1900) equation, while the acceleration is inversely proportional to the lesser electron mass relative to normal electron mass. Therefore, the greater-than-normal acceleration of low-mass electrons, allows the re-radiation of magnified inductive-photon energy at a magnification factor which is proportional to the inverse square of the electron's mass, e.g., the inductive-energy magnification factor of cadmium selenide photoelectrons with 0.13 of the normal electron mass is $(0.13)^2$ which is 59 times.

Electrons appear to acquire or shed mass from photons in order to fit the constraints of particular orbits around nuclei, because each orbit dictates a very specific electron mass. In metals, where the conduction electrons seem to move as would a gas, one might think that they would assume the normal mass of free electrons. But the largest mean free path of electrons in the most conductive metals is reportedly about 100 atomic spacings between collisions (Pops, 1997), so the conduction electrons apparently fall back into orbit from time to time and thereby regain their metal-specific mass values.

As conduction electrons pass from one metal type to another, they either lose or gain heat-photons to adjust their mass to different orbital constraints. In a circuit comprising two different metallic conductors placed in series contact with each other, the flow of conduction electrons in one direction will cause the emission of heat-photons at the junction, while an electron flow in the reverse direction causes cooling as the result of ambient heat-photons being absorbed by the conduction electrons at the junction (Peltier cooling effect). When a metal is joined with a semiconductor whose conductive electrons have much lower mass than in metals, much greater heating or cooling occurs at their junction.

John Bardeen (1941) reported that the (effective) mass of superconducting electrons in low-temperature superconductors is only 10^{-4} as great as the mass of normal electrons. This is demonstrated when superconducting electrons are accelerated to a much higher circular velocity than normal in diamagnetically induced eddy currents, which results in enormous magnetic forces which are capable of levitating heavy magnetic objects. Electrons with 10^{-4} times normal mass are apparently devoid, (or nearly devoid) of included photon mass, so normal electrons are deduced to possess about 10^4 times more included photon mass than the bare electron's own mass.

The means by which photon mass may be incorporated within, or ejected from electrons, can be deduced from known information. Based on the Thompson scattering cross-section, the classical radius of a normal electron is 2×10^{-15} cm. If the electron has uniform charge throughout a sphere of that radius, the peripheral velocity would greatly exceed the velocity of light in order to provide the observed magnetic moment. Dehmelt (1989) determined that the radius of the spinning charge which creates an electron's magnetism, is approximately 10^{-20} cm. This apparent incongruity can be explained if the electron is considered to be a hollow shell (which is commensurate with the bare electron's tiny mass in comparison to the very large radius) and if the negative charge of the shell is not the source of the magnetic moment.

It has long been known that a photon can be split into a negative ion (electron) and a positive ion (positron), each having the same amount of charge but of opposite sign. Electrons and positrons can recombine into electrically neutral photons, so it is apparent that photons are composed of a positive and a negative ion. Two

ions spinning around each other could produce the photon's wave nature. The only size of photon ion that can exist as a separate entity has a charge of exactly plus one or minus one, whereas the ions can have a very much larger or very much smaller charge and mass when combined in photons, as long as the two ions are equal in charge and mass. Combined in a photon, the two ions are apparently attracted together so strongly that their individual volumes are very much smaller than as separate entities.

When a dipole photon enters an electron shell, its negative-ion portion is expected to be forced towards the shell's centre by Coulombic repulsion, while the photon's positive ion would be attracted by the negative charge of the shell equally in all directions. The negative photon ions would likely merge into a single body at the electron's centre, while the positive-ion portion would orbit around the centralised negative ion to retain the photon's angular momentum. The high peripheral velocity of this orbiting photon mass would enable portions of photon material to spin off and exit the electron shell at the same velocity at which they entered the electron, i.e., the speed of light. The orbiting of the positive photon charge at Dehmelt's small radius, most likely accounts for the magnetic moment that is observed in electrons of normal mass.

Liberated low-mass conduction electrons within intrinsic semiconductors (which are also photoconductors by their nature) and within doped semiconductors, are mostly protected against acquiring mass from ambient-heat photons by the heat-insulative properties of the semiconductors. In contrast, low-mass electrons injected into heat-conducting metals, rapidly acquire mass from ambient-heat photons by the existence of cryogenic conditions, but they are vulnerable to internal heat-photons created by excessive induction.

Conduction electrons of metals, typically move as a group at drift velocities of less than one millimetre per second, although the velocity of the electrical effects approaches the velocity of light. (Photons are probably involved in the movement of electrical energy in metallic conductors.) In contrast, conductive low-mass electrons can move individually at great velocities in superconductors and semiconductors. Brennan (1999, p. 631) reports the drift velocity of a particular electron moving in a semiconductor, to be one micrometer in about 10 picoseconds, which is equivalent to 100 kilometers per second.

The concentration of the conduction electrons in metals is the same as the number of atoms, whereas in semiconductors, the mobile low-mass electrons which are free to move, can vary greatly with the amount of certain photon radiation received. Since the magnitude of an electric current is a summation of the number of electrons involved, times their respective drift velocities, the current developed by a small ensemble of photoconducting electrons moving at high speed, can exceed the current of a much greater number of conduction electrons moving at a very low speed in a metal.

A general feature of intrinsic semiconductors is that they become photoconductive in proportion to the amount of bombardment by some particular electron-liberating frequency (or band of frequencies) of photon energy, up to some limit. The amount of bombardment by the particular wavelength (or, equivalently, the frequency), increases along with all other photon wavelengths as the ambient temperature rises, that is, as the area under Planck's black-body radiation curve increases. Consequently, the conductivity of semiconductors continues to increase with temperature, while the conductivity drops to almost zero at low temperature unless superconductivity occurs.

A single high-energy alpha particle can liberate a great number of low-mass electrons in a thin-film semiconductor, as Leimer's (1915) energy-magnifying experiment appears to show. Leimer's alpha radiation was situated near the distant end of a suspended antenna wire of unreported length, when he experienced the maximum magnetic energy increase in the coil of the ammeter in the receiver. The low-mass electrons had to have travelled the entire length of the suspended antenna and the connecting line to his receiving apparatus without encountering any trapping holes. Assuming these electrons traversed a distance of 1 to 10 metres in less than one half-cycle of the radio frequency, (that is, less than 4 microseconds at 128 kHz) at which time the direction of the low-mass electron would have been reversed, this would be equivalent to velocities of 25 to 250 km/sec.

A great number of superconducting electrons can be set in motion by inductive photon radiation. In contrast, inductive photon radiation can pass mostly through photoconductors that have low concentrations of mobile, low-mass electrons. Applicant's interpretation of Leimer's experiment is that the liberated low-mass electrons of the semiconductor coating of the antenna wire, were not directly accelerated by the inductive photons of the radio signal, but rather were accelerated to high velocities by an oscillating electric field created in the metallic wire by the radio photons.

A review of an experiment performed by File and Mills (1963), shows that the very low mass of superconducting electrons is responsible for causing supercurrents to differ from normal electric currents. A superconducting solenoidal coil (comprising a Nb-25% Zr alloy wire below 4.3⁰ K.) with the terminals spot-welded together to make a continuous conductor, was employed. Extremely slow declines of induced supercurrents were observed, which can be attributed to an enormous increase in the coil's self-induction. Because a supercurrent approaches its maximum charge asymptotically when discharging, a convenient measure of the coil's charging or discharging rate is the "time-constant". The time-constant has the same value for both charging and discharging, and it is defined as (a) the time needed for charging the coil to 63% of the maximum amount of current inducible in the coil by a given diamagnetic force, or (b) the time needed to discharge 63% of the coil's induced current.

In normal conductors, the inductive time-constant is calculated by the inductance of the coil, divided by the resistance of the coil. By use of an empirical equation, the inductance of the coil in its non-superconducting state is calculated to be 0.34 Henry, based on a double-layered solenoid of 384 turns that measured 4 inches (10 cm) diameter and 10 inches (25 cm) long. The resistance of the 0.020 inch (0.51 mm) diameter wire at a temperature of 5⁰ K. (just above T_c) is estimated by using data for Zr alone, to be 4 x 10² ohms. (Resistivity data were not available for Nb or the subject alloy). Under non-superconducting conditions, the time-constant for charging and discharging this coil is thereby calculated to be approximately 8 x 10⁻⁵ sec.

The time it took to charge up a supercurrent in the coil in the experiment was not reported. But, based on the reported 50 re-energisings and magnetic determinations performed in 200 hours, the measured charging time in the superconducting state is computed to be no more than 4 hours on average.

Using Bardeen's (1941) formula of m is approximately equal to m_e times 10⁻⁴ for the order of magnitude of the low T_c superconducting electron's mass, and using Larmor's equation (1900) which relates inductive radiation power to the square of the acceleration of the charge, the inductance of the coil is expected to increase by (10⁴)² = 10⁸ times in the superconducting state. Thus, the calculated increase in the time-constant of charging up the supercurrent is 8 x 10⁻⁵ x 10⁸ which equals 8 x 10³ seconds, or 2.2 hours, which is the same order of magnitude as the maximum actual charging time. The self-induction increased by that amount because the low-mass electrons are accelerated 10⁴ times faster.

In the case of discharging, the time constant of the supercurrent was projected by File and Mills from measured declines observed over periods of 21 and 37 days. The projections of the two 63% declines agreed closely at 4 x 10¹² seconds (= 1.3 x 10⁵ years). Therefore, the time-constant of supercurrent discharge, based on projecting actual measurements, had increased by 5 x 10¹⁶ times over the time-constant for electrons of normal mass.

The driving force during charging, had been the applied inductive force, whereas the driving force during discharging was the supercurrent that had been magnified 10⁸ times. Therefore, during the discharging of the supercurrent, the time-constant is increased again by 10⁸ times, so the calculated total increase in the time-constant of discharge is 10⁸ x 10⁸ = 10¹⁶ times greater than the normal time-constant. This calculated value of the non-superconducting time-constant, based solely on the increase of inductive radiation due to extremely low electron mass, compares favourably in magnitude with the actually observed value of 5 x 10¹⁶ times the normal time-constant.

The superconducting coil required no more than four hours to charge up the supercurrent, yet during subsequent discharge, the superconducting coil was projected to radiate inductive photon energy from the centripetal acceleration of the superconducting electrons for 130,000 years before declining by 63%. If this experiment could take place where no energy would needed to sustain critical cryogenic conditions, as in outer space, the lengthy discharge of this energised coil would clearly demonstrate the creation of energy in the form of newly-created photons inductively radiating from the superconducting low-mass electrons that circulate around the coil's loops. Applicant interprets this as showing that low-mass electrons are capable of inductive-energy-magnification based solely on their mass relative to that of normal electrons.

In the embodiments described below, the magnified inductive energy of low-mass electrons is utilised in coils for electric-energy generation by employing a flow of inductively accelerated photons that alternates in direction. This, in turn, drives low-mass electrons in an oscillating manner, so this forced reversal involves only a single stage of inductive-energy magnification, rather than the two stages (charging and naturally discharging) in the foregoing experiment.

Mode of Operation

Inductive photons radiating from an oscillating electric current in a sending conductor (e.g. from a radio-wave broadcasting antenna) convey a force, on conduction electrons in a receiving conductor, that is transverse to the incidence direction of the incident inductive photons on the receiving conductor. As a result, no back-force is transferred directly back to the sending conductor. Applicant has discovered that the action of this transverse force on low-mass electrons in a receiving conductor is analogous to the action of Gauss's transverse magnetic force on free electrons in a conductor, which is not subject to the kinetics law of conservation of energy. If the receiving conductor has low-mass conduction electrons, then this transverse force would impart greater acceleration to the low-mass electrons than that it would impart to normal free electrons. The resulting greater drift velocities of low-mass electrons than normal free electrons in the receiving conductor, would yield an increased magnitude of inductive force produced by the low-mass electrons in the receiving conductor and hence produce a magnification of the irradiation energy of inductive photons.

The direction of the transverse force imparted by the radiated inductive photons on conduction electrons in the receiving conductor is opposite to the direction of the corresponding electron flow in the sending conductor. This

relationship is similar to the inductive force on electrons in the secondary coil of a transformer, which also is opposite to the direction of flow of electrons in the primary coil.

Various embodiments of Applicant's electrical generator employ inductive photons radiated from electrical oscillations in a "sending coil". Inductive photons are radiated from the sending coil toward and inductive-photon receiving coil, termed an "energy-magnifying coil", which comprises a photoconductive or superconductive material, or other suitable material as described below. The energy-magnifying coil is placed in a condition favourable for the production of low-mass electrons that participate in electrical conduction in the energy-magnifying coil. For example, if the energy-magnifying coil is made of photoconductive material, the coil is provided with a photoconduction exciter. Alternatively, if the energy-magnifying coil is made of a superconductive material, the coil is placed in an environment at a temperature (T) no greater than the critical temperature (T_c); i.e., $T < T_c$. In the former example, the photoconduction exciter can be a source of illumination which provides an appropriate wavelength of excitive electrokinetic radiation. If the energy-magnifying coil is comprised of a doped semiconductor, the condition that provides mobile low-mass electrons already exists.

In the energy-magnifying coil, the greater-than-normal acceleration of the low-mass electrons produces greater-than-normal inductive forces in the form of greater-than-normal radiation of inductive photons from the coil. The resulting increased inductive-photon energy from the photoconductor or superconductor is converted into useful electrical energy in an output coil inductively coupled to the energy-magnifying coil. The output coil can be made of insulated metallic wire. An exemplary output coil is situated coaxially with, and nested within, the energy-magnification coil. A coil of this type is termed herein, an "internal output coil".

The ability of the subject apparatus to produce more energy output than energy input, is based on the output coil receiving more of the magnified energy from the energy-magnifying coil than is returned as a back-force from the output coil to the energy-magnifying coil. This principle is termed herein "energy leverage".

The oscillations in the energy-magnifying coil are initiated by an external energy-input source that provides an initiating impulse of electron flow in the sending coil. For example, the external energy-input source can be an adjacent independent electromagnet or an adjacent permanent magnet moved rapidly relative to the sending coil. The initiating impulse starts an oscillation in the sending coil that stimulates radiation of inductive photons from the sending coil to the energy-magnifying coil. Energy from the external energy-input source is magnified by the apparatus so long as the energy-magnifying coil does not act as an independent oscillator at a different frequency. Independent oscillation is desirably avoided by connecting the ends or terminals of the energy-magnifying coil to each other in such a way that it results in one continuous coil, or a continuous multiple-coil system or systems, connected together in such a way that continuity exists for the conduction of low-mass electrons throughout the entire coil system. The energy-magnifying coil inductively creates more energy in the output coil than the energy of the initial impulse. The resulting magnified output of electrical energy produced by the apparatus is available for useful purposes in a work loop.

After initiation, the apparatus is made self-sustaining using a feed-back loop arranged in parallel with the work loop that includes the sending coil, and with a capacitor located in the feed-back loop to make it an L-C circuit, i.e., after start-up of the apparatus using the external energy-input source, the apparatus becomes self-resonating, which allows the external energy-input source to be decoupled from the apparatus without causing the apparatus to cease production of electrical energy.

During normal self-sustained operation, a portion of the output electrical energy is returned to the sending coil by the feed-back loop, thereby overcoming the need to use the external energy-input source for sustaining the oscillations in the sending coil. In other words, after startup, the external energy which was used by the sending coil to excite the photoconductive material or the superconducting material in the energy-magnifying coil is replaced by a portion of the output energy produced by the apparatus itself. The remainder of the output electrical energy is available in the work loop for useful purposes.

Initiating the generation of electrical energy by the apparatus, takes advantage of the fact that the inductive back-force sent from the output coil to the energy-magnifying coil (and hence ultimately, back to the sending coil), arrives at the sending coil one cycle behind the corresponding pulse that initiated the flow of electrons. This one-cycle lag of the back-force, as well as a corresponding one-cycle lag in the feed-back, enables small starting pulses produced in the sending coil to produce progressively greater electrical outputs each successive cycle. Consequently, assuming that the electrical load is not excessive during start-up, only a relatively few initiating cycles from the external energy-input source typically are needed for achieving production by the apparatus of an amount of output power sufficient to drive the load as well as providing sufficient energy feed-back to the sending coil in a sustained manner.

A half-cycle of the one-cycle lag occurs between an initial acceleration of electrons in the sending coil and a corresponding initial oscillation in the energy-magnifying coil. This half-cycle lag occurs because induction photons are not radiated from the initial acceleration of electrons in the sending coil, but rather are radiated when the electrons are reverse-accelerated. (Kramers, 1923, and Compton and Allison, 1935, p.106). As the newly formed photons are being radiated by the respective deceleration of electrons in the sending coil, even more new photons are simultaneously being formed by the new direction (i.e. reverse direction) of acceleration under

oscillating conditions. Thus, the radiation of photons from electrons alternatingly accelerated in the opposite direction from the conveyed force, continues each half-cycle after the initial half-cycle.

Applicant also discovered that a half-cycle lag also occurs between the initial flow of electrons in the primary coil of a certain type of transformer, which is simply comprised of coils nested coaxially rather than being inductively coupled by an iron core, and the resulting electron flow induced in the secondary coil. When applied to this apparatus, these findings indicate that a second half-cycle lag occurs between the acceleration of low-mass electrons in the energy-magnifying coil and the corresponding electron flow induced in the output coil. The feedback from the output coil boosts the electron flow in the sending coil one whole cycle after the initial pulse.

As discussed above, the energy-magnifying coil comprises either a photoconductor, a doped semiconductor or a superconductor as a source of, and as a conductor of, low-mass electrons. The general configuration of the coil is similar in either case. The coil including a photoconductor or doped semiconductor, has an operational advantage at normal temperatures, and the coil including a superconductor has an operational advantage at sub-critical temperatures ($T < T_c$), such as in outer space.

Representative Embodiments

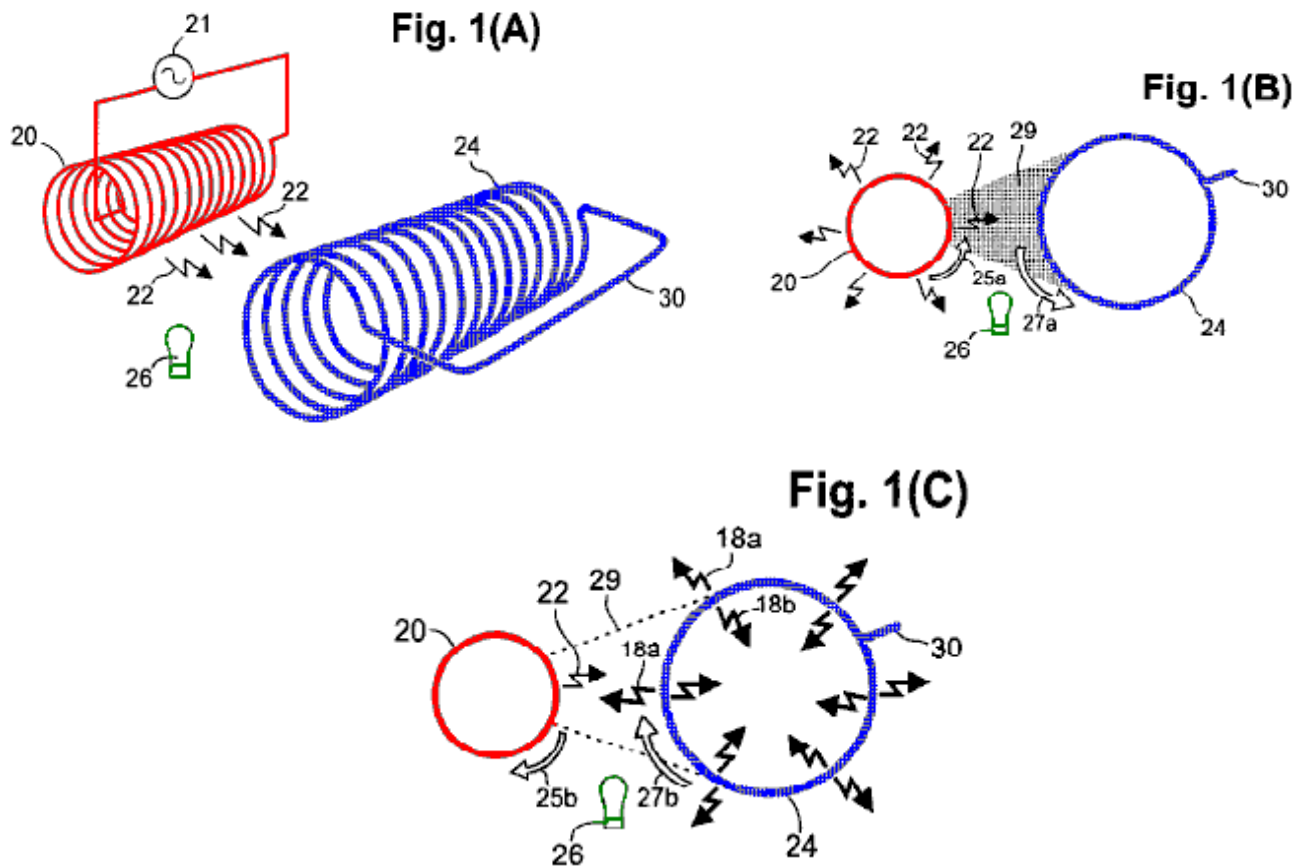

Reference is now made to **Fig.1A** to **Fig.1C** and **Fig.2A** and **Fig.2B** which depict a sending coil **20** connected to a source of alternating current **21**. The sending coil is shown having a desirable cylindrical profile, desirably with a circular cross-section as the most efficient configuration. In **Fig.1A** and **Fig.1B**, electrical oscillations from the source **21** are conducted to the sending coil **20** where they cause inductive photons **22** to radiate from the sending coil. The radiated photons **22** convey transverse forces in the same manner that a radio-broadcasting antenna transmits oscillating energy. The sending coil **20** can be a single layer or multiple layers of insulated metal wire (e.g. insulated copper wire). One layer is sufficient, but an additional layer or layers may increase operational efficiency. If necessary, or desired, the turns of wire can be formed on a cylindrical substrate made of a suitable dielectric.

The inductive photons **22** radiating from the sending coil **20**, propagate to an energy-magnifying coil **24** that desirably has a cylindrical profile extending parallel to the sending coil. In the embodiment shown in **Fig.1A** and **Fig.1B**, the energy-magnifying coil **24** does not terminate at the ends, but rather, it is constructed with a connector **30** to form a continuous conductor. The energy-magnifying coil **24** desirably is a helical coil made of a material comprising a photoconductive or superconductive material, or other suitable material. If necessary or desired, the energy-magnifying coil can be formed on a substrate which, if used, desirably is transmissive to the inductive-photon radiation produced by the coil.

In an energy-magnifying coil **24** made of a superconducting material, a large population of conductive low-mass electrons is produced in the coil by lowering the temperature of the coil to a point below the critical temperature for that material. By way of an example, sub-critical temperatures are readily available in outer space or are produced under cryogenic conditions.

In an energy-magnifying coil **24** made of a photoconductor material, a large population of conductive low-mass electrons is produced in the coil by illuminating the coil with photons of an appropriate wavelength, such as photons produced by a photoconduction exciter **26**. The photoconductor exciter **26** desirably is situated and configured so as to illuminate substantially at least the same side of the energy-magnifying coil **24** that receives inductive photons **22** radiating directly from the sending coil **20**. Alternatively, the photoconduction exciter **26** can be situated and configured so as to illuminate all sides of the energy-magnifying coil **24**. In the depicted embodiment, the photoconduction exciter **26** can be at least one incandescent lamp (as shown) energised by conventional circuitry (not shown). Alternatively, the photoconduction exciter **26** can be at least one gas-discharge lamp or one or more Light Emitting Diodes. The wavelength produced by the photoconduction exciter **26** can be, for example, in the infrared (IR), visible, ultraviolet (UV), or X-ray range as required by the particular photoconductor material in the energy-magnifying coil **24**. Another possible form of the photoconduction exciter **26**, is a source of photons in the gigahertz or the terahertz portion of the electrokinetic spectrum. Other photoconduction exciters are configured, as required, to produce a suitable wavelength from the radio-wave portion of the electrokinetic spectrum. The illumination can be either direct from the photoconduction exciter **26** to the energy-magnifying coil **24** or conveyed from a remotely located photoconduction exciter to the energy-magnifying coil via optical fibres, light pipes, or the like.

Fig.1B and **Fig.1C** are respective orthogonal end views of the sending coil **20** and energy-magnifying coil **24** shown in **Fig.1A**. The radiation of inductive photons **22** from the sending coil **20**, is indicated schematically in **Fig.1A**, **Fig.1B** and **Fig.1C** by small, jagged arrows. The forces delivered by the photons **22** to the conductive low-mass electrons in the energy-magnifying coil **24**, alternate in directions which are opposite to the respective directions of simultaneous electron flow in the sending coil **20**. Whenever the particular oscillation phase of electron flow in the sending coil **20** is in the direction of the curved arrow **25a** adjacent to the sending coil **20** in **Fig.1B**, the resulting transverse photon force causes a flow of low-mass electrons in the energy-magnifying coil **24**, depicted by the curved arrow **27a** adjacent to the energy-magnifying coil **24**.

The shaded sector **29**, shown in **Fig.1B**, denotes the proportion of inductive-photon radiation **22** from the sending coil **20**, actually received by the single energy-magnifying coil **24** shown, compared to the entire 360-degree radiation of inductive photons **22** from the sending coil **20**. Aside from a small amount of inductive-photon radiation lost from the ends of the sending coil **20**, the relative amount of the total energy of inductive-photon radiation received by the energy-magnifying coil **24** is determined by the angle subtended by the energy-magnifying coil **24**, relative to the entire 360 degrees of inductive-photon radiation from the sending coil **20**.

In **Fig.1C**, the low-mass conduction electrons of the energy-magnifying coil **24** are accelerated to a higher drift velocity than normal free electrons in the energy-magnifying coil **24** would be. As noted above, the sending coil **20** is energised by alternating electron flow, which causes a periodic reversal of direction of electron flow in the sending coil **20** (compare the direction of the arrow **25b** in **Fig.1C** with the direction of the arrow **25a** in **Fig.1B**). Each reversal of direction of electron flow in the sending coil **20**, causes a corresponding reversal in the direction of acceleration of the low-mass electrons in the energy-magnifying coil **24** (compare the direction of the arrow **27b** in **Fig.1C** with the direction of arrow **27a** in **Fig.1B**). Each such reversal in direction of acceleration causes a corresponding radiation of inductive photons (jagged arrows **18a**, **18b**) radially outwards and radially inwards, respectively, from the energy-magnifying coil **24**. Note that the arrows **18a** and **18b** are larger than the arrows denoting the inductive photons (arrows **22**) from the sending coil **20**. This symbolically denotes energy magnification. Note also that, of the magnified inductive-photon energy radiating from the energy-magnifying coil **24**, substantially half is directed inwards (arrows **18b**), and substantially the other half is radiated outwards (arrows **18a**).

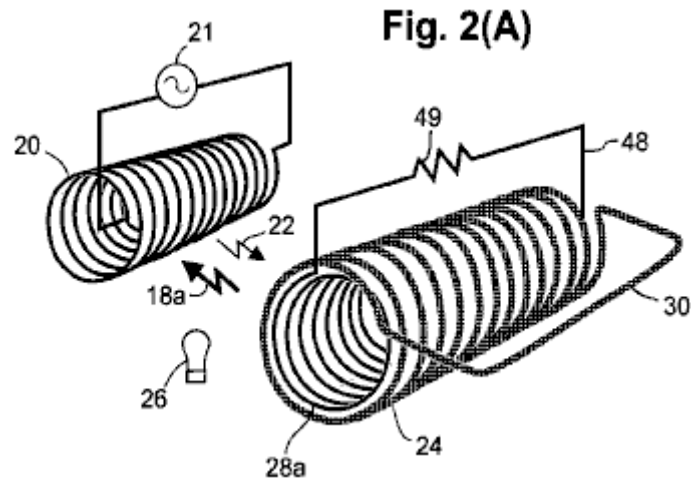

Turning now to **Fig.2A**, the sending coil **20**, and the energy-magnifying coil **24**, are shown. The energy-magnifying coil **24** in **Fig.2A** includes an internal output coil **28a**, that desirably is situated co-axially inside and is of the same length as the energy-magnifying coil **24**. A work loop **48** can be connected to the ends of the internal output coil **28a**, thereby forming an electrical circuit in which a load **49** is indicated symbolically as a resistor. The internal output coil **28a** and the conductors of the work loop **48**, desirably are made of insulated metallic (e.g. copper) wire.

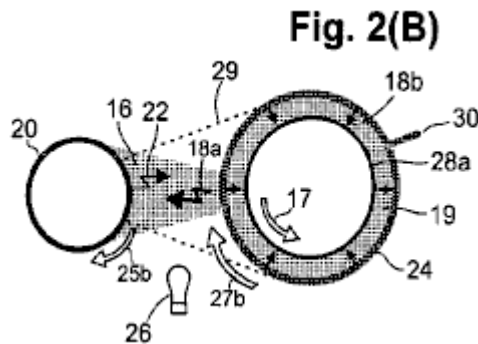

Fig.2B depicts a transverse section of the coils shown in **Fig.2A**. In **Fig.2B**, the magnified inductive-photon energy (shaded area **19**) produced by the energy-magnifying coil **24** and directed radially inwards towards the internal output coil **28a**, induces a corresponding oscillating electron flow in the internal output coil **28a**. Thus, the work loop **48** connected across the internal output coil **28a**, is provided with greater energy than was received by the energy-magnifying coil **24** from the sending coil **20**. The direction of the electron flow (arrow **17**) in the internal output coil **28a**, is opposite to the direction of flow (arrow **27b**) in the energy-magnifying coil **24**, which in turn is opposite to the direction of electron flow **25b** in the sending coil **20**.

In **Fig.2B**, the annular-shaped shaded area **19** between the energy-magnifying coil **24** and the internal output coil **28a**, indicates that substantially all of the internally-directed magnified inductive-photon energy (i.e. approximately half of the total radiation energy) from the energy-magnifying coil **24**, is directed to, and captured by, the internal output coil **28a**. In contrast, the shaded sector **16** extending from the energy-magnifying coil **24** to the sending coil **20**, indicates that a relatively small proportion of the outwardly directed magnified radiation **18a** from the energy-magnifying coil **24** is directed to the sending coil **20** where the radiation provides a corresponding back-force. Aside from the small amount of inductive-photon radiation lost from the ends of the energy-magnifying coil **24**, the relative amount of the magnified inductive-photon radiation (sector **16**) providing the back-force on the sending coil **20**, is a function of the angle subtended by the sector **16**, compared to the 360-degree radiation from the energy-magnifying coil **24**.

The ratio of magnified energy **18b** from the energy-magnifying coil **24** and received by the internal output coil **28a**, to the magnified energy **18a** received as a back-force by the sending coil **20**, denotes the energy "leverage" achieved by the subject apparatus. If this ratio is greater than unity, then the energy output from the internal output coil **28a** exceeds the energy input to the energy-magnifying coil **24**. This energy leverage is key to the self-sustained operation of the apparatus, especially whenever the apparatus is being used to drive a load. In other words, , with a sufficiently large energy-magnification factor achieved by the energy-magnifying coil **24**, the electrical energy available in the work loop **48**, exceeds the input energy that produces the oscillations in the sending coil **20**. The electric power input to the sending coil **20** thereby produces magnified electric power in the internal output coil **28a** that can perform useful work in the work loop **48** while self-powering the continued operation of the apparatus.

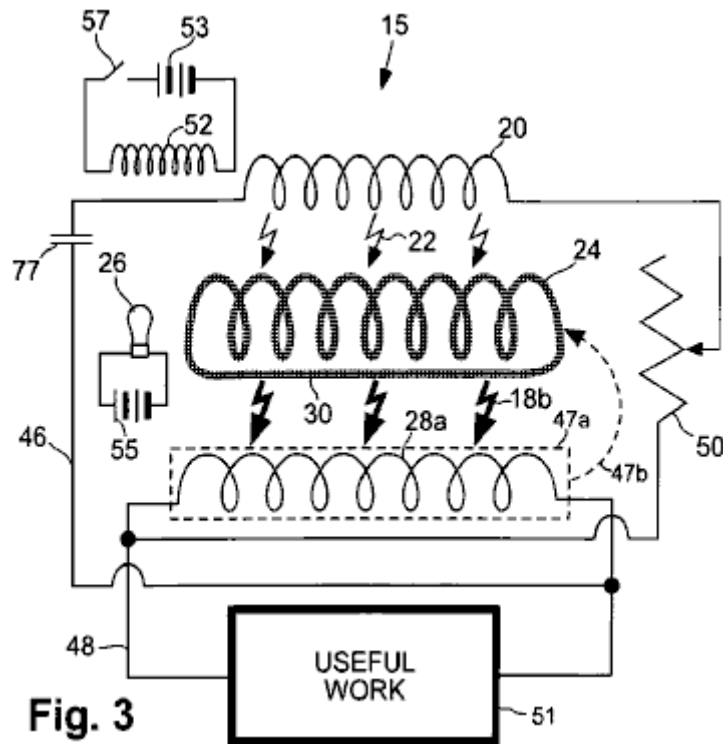

Fig. 3

Reference is now made to **Fig.3**, which schematically depicts aspects of the apparatus **15**, responsible for self-generation of electric power by employing a feed-back loop **46**. The conductors of the feed-back loop **46** can be made of insulated metallic wire. (In **Fig.3**, the dotted lines **47a** and dotted arrow **47b**, indicate that the internal output coil **28a** is actually positioned co-axially inside the energy-magnifying coil **24**, as described above, but is depicted in the figure as being outside the energy-magnifying coil for ease of illustration). The feed-back loop **46**, conducts a portion of the electric power from the internal output coil **28a**, back to the sending coil **20**. The remaining portion of the electric power from the internal output coil **28a** is directed to the work loop **48** where the power is utilised for useful work **51**. The relative proportions of output power delivered to the feed-back loop **46** and to the work loop **48**, can be varied by adjusting a variable resistor **50**.

As noted above, an initial source of electrical energy is used for “starting” the apparatus **15** by initiating an oscillation in the sending coil **20**. After starting, under usual operating conditions, the apparatus **15** is self-resonant and no longer requires the input of energy from the initial source. The particular inductance and distributed capacitance of the sending coil **20**, plus all other capacitances and inductances in the apparatus, provide a certain corresponding frequency of self-resonating oscillation. In the feed-back loop **46** is a capacitor **77** that makes the apparatus an L-C circuit which oscillates at its own frequency. the frequency can be changed by altering the capacitance or inductance of the apparatus, or both. the capacitor **77** can be a variable capacitor by which the frequency can be adjusted.

As shown in **Fig.3**, the initial source of oscillating electrical energy can be an impulse from an external electromagnet **52** powered by its own energy source (e.g. a battery **53** as shown, or other DC or AC source). For example, the electromagnet **52** can be placed near the sending coil **20** or other portion of the feed-back loop **46**, and energised by a momentary discharge delivered from the battery **53** via a switch **57**. The resulting pulse generated in the electromagnet **52**, initiates a corresponding electrical pulse in the sending coil **20** that initiates self-sustaining oscillations in the apparatus **15**. In another embodiment, the electromagnet **52** can be energised briefly by an AC source (not shown). In yet another embodiment, the initial source can be a permanent magnet which is moved rapidly (either mechanically or manually) near the sending coil **20** or other portion of the feed-back circuitry. In any event, the pulse provided by the initial source initiates electrical oscillations in the sending coil **20** that produce corresponding oscillating inductive-photon radiation **22** from the sending coil **20**, as shown schematically in **Fig.3** by thin jagged arrows. The inductive-photon radiation **22** from the sending coil **20** causes, in turn, re-radiation of magnified inductive-photon energy **18b** from low-mass electrons in the energy-magnifying coil **24**, as shown schematically in **Fig.3** by thick jagged arrows. **Fig.3** depicts a photoconductive energy-magnifying coil **24** which is illuminated by an incandescent photoconduction exciter **26** energised by its own power source **55** (e.g., an externally connected battery as shown).

A sufficiently high energy-magnification factor of the apparatus **15** allows the magnified energy from the energy-magnifying coil **24** to induce greater energy in the internal output coil **28a** than the energy of the corresponding initial pulse. A portion of the magnified electrical energy is returned to the sending coil **20** via the feed-back loop **46** to sustain the oscillations.

The remaining surplus energy from the internal output coil **28a** is available for application to useful work via the work loop **48**. In one embodiment, some of this useful work can be used for illuminating the photoconduction exciter **26** (circuitry not shown) in an apparatus configuration in which the energy-magnifying coil **24** comprises a photoconductor. In another embodiment, some of this useful work can be used for maintaining cryogenic ($T < T_c$) conditions for an apparatus configuration in which the energy-magnifying coil **24** comprises a semiconductor.

After starting oscillations in the apparatus **15**, electron flow builds up rapidly, so long as the load **49** does not draw off too much of the output energy during start-up. Upon reaching operating equilibrium, the output of electrical power from the apparatus **15** is a rapidly alternating current (AC). The AC output can be rectified by conventional means to produce direct current (DC), and the output can be regulated as required, using conventional means. Many variations of conventional circuitry are possible, such as, but not limited to, automatic voltage controllers, current controllers, solenoidal switches, transformers, and rectifiers,

Regarding the energy-magnifying coil **24**, an exemplary embodiment can be made from a low - T_c superconductor such as commercially available, flexible, niobium-zirconium wire which can be readily formed into a coil.. Other embodiments, as noted above, of the energy-magnifying coil **24** can be made using a photoconductive material or a high - T_c superconductor. Most high - T_c superconductors (and some photoconductors) have ceramic-like properties and thus require the application of special methods for forming the material into a cylindrical coil having electrical continuity throughout. Some commercially available high - T_c superconductors are available in ribbon or tape form. The energy-magnifying coil **24** can be free-standing or supported on a rigid substrate.

By way of example, an energy-magnifying coil **24** can be made from a ribbon of flexible photoconductive material such as the material discussed in patent US 6,310,281, incorporated herein for reference. Briefly, a layer of stress-compliant metal is placed on a plastic ribbon. Then the photoconductive material is deposited on both sides of the metal-covered ribbon and the edges of the ribbon so that the ribbon is coated all the way around. Such a configuration allows low-mass electrons in the photoconductive material, to receive energy from inductive-photons emitted from the sending coil **20** on one side of the ribbon while re-radiating magnified energy from both sides of the ribbon.

In another example, a flexible photoconductor ribbon is made from flexible organic polymer having photoconductive properties. (High electrical conductivity observed in photoconductive polymers is attributed to the presence of low-mass electrons in the material). The flexible photoconductive ribbon can be wound on a dielectric tubular support, to form the energy-magnifying coil **24**.

In yet another example, a thick-film coating of photoconductive cadmium sulphide (CdS) or cadmium selenide (CdSe) is formed on a wire coil by sintering as paste, which comprises a powder of finely ground CdS or CdSe crystals mixed with water and at least a fluidiser such as cadmium chloride, at a temperature of 550°C . to 600°C . in a controlled atmosphere. During sintering, the boundaries of the small crystals become melted with the heated fluidiser, allowing the crystals to regrow together and solidify when the fluidiser evaporates and the sintered coating is cooled. Alternatively, copper oxides are formed in place on bare copper or bronze wire by heating the wire above about 260°C . in an oxygen atmosphere, or by application of chemical oxidants.

In yet another example, a coil of ceramic-like superconductor or photoconductor is made by tape-casting, extruding, slip-casting, cold or hot-pressing, or coating of the material as a thin film arranged helically on a tubular dielectric substrate. The assembly is heat-treated in a controlled atmosphere furnace to increase inter-crystalline contacts. Alternatively, the thin film of superconductor or photoconductor is formed over the entire exterior of the dielectric substrate, followed by removal of selected portions of the superconductor or photoconductor to form the desired helical coil.

[121]In some photoconductors and doped semiconductors, only a small portion of a population of inductive photons irradiated on the material, impact with, and yield acceleration of, low-mass electrons in the material. This is due to a low density of photoconductive low-mass electrons in the material. In such as case, inductive-photon radiation passing through the material can be captured efficiently by normal free conduction electrons in a metallic strip that desirably is in immediate contact with, or embedded in, the material. The acceleration of normal free electrons in the metallic conductor, sets up an electric field that assists in accelerating the low-mass photoelectrons. In this configuration, it is desirable that the photoconductive material be disposed completely over and around the metallic strip so that the photoconductor faces both outwards and inwards, with both sides of the photoconductor or doped semiconductor being in electrical contact with each other.

One factor in the choice of photoconductor material to use in forming the energy-magnifying coil **24** is the potential magnification of energy that can be realised by low-mass electrons of an n-type or p-type photoconductive material. Other important factors are the quantity of low-mass electrons that are available in the photoconductive material for a given amount of illumination and the actual electrical conductance of the material. Standard illumination-sensitivity measurements provide a general overall index of the ability of a photoconductor to serve effectively in magnifying energy.

Cadmium sulphide and cadmium selenide, the most common photoconductive compounds which are available commercially, have calculated magnification factors of 37 and 59, respectively. The peak response wavelength of cadmium sulphide is 515 nanometers (in the green part of the visible spectrum) and of cadmium selenide is 730 nanometers (in the near-infrared part of the spectrum). Cadmium sulphide can be mixed with caesium selenide under certain conditions, so the resulting mixture assumes photoconductive characteristics between those two values. Mixtures can be produced having peak wavelengths which are matched to the wavelengths of commercially available LEDs of many sizes and illumination intensities. Some semiconductors which become photoconductive at a wavelength smaller than the wavelength produced by currently available LEDs can be made conductive of low-mass electrons merely by heating.

Applicant has found that gallium arsenide develops considerably higher conductivity than copper or silver at a temperature of 100⁰ C. and that the conductive electrons are low-mass. Also, alpha radiation is capable of liberating many low-mass electrons in some semiconductors. A second electron of comparatively low mass may have been liberated from cupric oxide by alpha radiation along with the outer copper electron in Leimer's (1915) experiments, since the measured energy magnification exceeded the magnification calculated from cyclotron resonance of CuO, which most likely pertains only to the mass of the outer electron.

Dopants can be added to a semiconductor to make it more conductive of low-mass electrons without illumination. Also, the illumination-sensitivity and conductivity of cadmium sulphide are increased by adding small amounts of donor-type dopants such as, but not limited to, sulphides, selenides, tellurides, arsenides, antimonides and phosphides of the Type-IIIa elements: aluminium, gallium, indium and thallium. In this regard, the photoconductors of high-sensitivity photovoltaic cells may comprise as many as five different compounds. The actual mixtures of photoconductive compounds and dopants used in commercially available photovoltaic cells often are trade secrets. But, the sensitivity and conductances of the cells are usually given or are measurable, and these data can be used advantageously in selecting a particular photoconductive compound for use in the apparatus.

Other photoconductive compounds or elements can be employed in energy-magnifying coils. For example, the conduction electrons of silicon have an energy-magnification factor of 15 times. Photoconductors having very high magnification factors include, but are not limited to, gallium arsenide, indium phosphide, gallium antimonide, cadmium-tin arsenide, and cadmium arsenide, which have calculated energy-magnification factors ranging between 200 times and 500 times, and mercury selenide (1100 times), indium arsenide (2000 times), mercury telluride (3400 times) and indium antimonide (5100 times).

The depth of optical transmission largely determines the optimum thickness of photoconductive films for energy-magnifying coils. For example, the highest optical transmission of sintered CdS is reported to be 20 micrometers, but since the average grain size increases (and the average porosity decreases) with an increase in film thickness, the maximum conductivity of a sintered film is at a thickness of 35 micrometers (J. S, Lee et al., 1987).

The metal chosen to be embedded must not react chemically with the photoconductor. For example, aluminium reacts with gallium arsenide (GaAs) in an electrical environment, to change the conductive character of both the GaAs and the aluminium. Gold, platinum, and palladium can serve in many cases because these materials are relatively inert chemically. Gold combines chemically with tellurium, however, so gold is not suitable for embedding in mercury telluride. Cadmium plating over a common metal serves to alleviate the reactivity in cases where cadmium sulphide or cadmium selenide is used as the photoconductor.

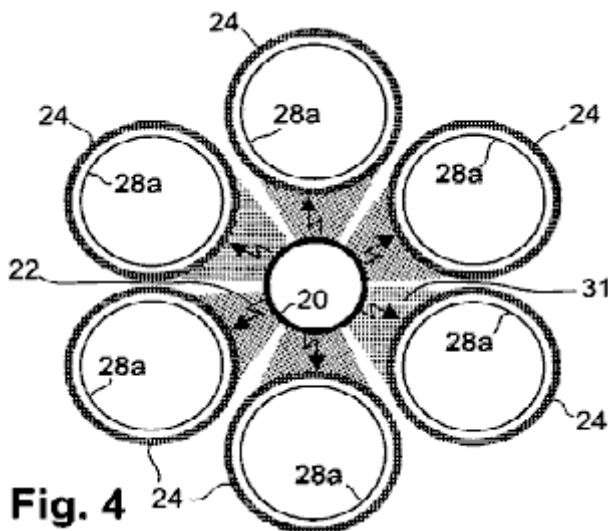

Fig. 4

The discussion above has been, for ease of explanation, in the context of the apparatus including one energy-magnifying coil **24**. However, as discussed, use of a single energy-magnifying coil **24** to capture inductive photons from the sending coil **20**, results in loss (by non-capture) of most of the inductive photons from the

sending coil 20. This proportion of captured inductive photons can be increased greatly in an embodiment in which multiple energy-magnifying coils 24 substantially completely surround the sending coil 20, such as shown in Fig.4. In this embodiment, the energy-magnifying coils 24 substantially completely surround the sending coil 20, and (although six energy-magnifying coils 24 are shown) as few as three energy-magnifying coils 24 of adequate diameter, still could substantially completely surround the sending coil 20. There is no limit, except as possibly related to packaging concerns, to the maximum number of energy-magnifying coils 24 which could be used. The depicted configuration of Fig.4, has a desirable number of six energy-magnifying coils 24. In Fig.4, the shaded sectors 31, considered collectively, illustrate that nearly all 360 degrees of inductive-photon radiation 22 from the sending coil 20, are received by the energy-magnifying coils 24. Not shown in Fig.4 are photoconduction exciters (items 26 in Fig.3) used for illuminating respective portions of the energy-magnifying coils 24 in a photoconductive form of the apparatus 15.

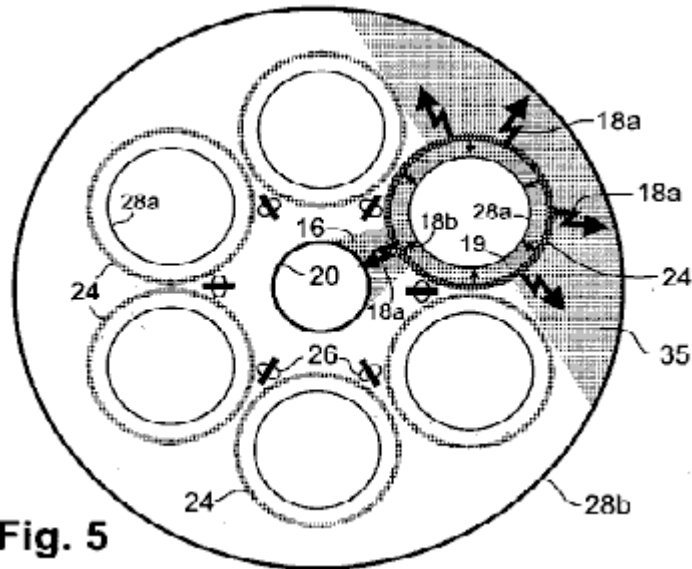

Fig. 5

Fig.4 also depicts respective internal output coils 28a nested co-axially and co-extensively inside each of the energy-magnifying coils 24. As discussed earlier, each internal output coil 28a receives nearly all the inductive-photon radiation propagating radially inwards from the respective energy-magnifying coil 24. Desirably, the overall energy output of the embodiment of Fig.4, can be increased by surrounding the array of energy-magnifying coils 24 with an external output coil 28b, of which the conductors desirably are made of insulated metallic wire (Fig.5). In this embodiment, approximately half of the outwardly propagating magnified inductive-photon radiation (large arrows 18) from each energy-magnifying coil 24 (one such coil is highlighted in Fig.5) is received by the external output coil 28b. This captured radiation is denoted by the shaded sector 35. When this externally directed inductive radiation captured from all the energy-magnifying coils 24 is added to all the inwardly directed radiation captured from the energy-magnifying coils 24 by their internal output coils 28a, 28b, greatly exceeds the back-force energy directed by the energy-magnifying coils 24 towards the sending coil 20 (the back-force energy from one energy-magnifying coil 24 is shown as the shaded sector 16). Thus, the resulting energy "leverage" exhibited by the apparatus is increased substantially by including the external output coil 28b.

The embodiment of Fig.5 also includes respective arrays (viewed endwise) of light-emitting diodes (LEDs) collectively serving as photoconductor exciters 26 for the energy-magnifying coils 24. The LED arrays are arranged back-to-back and disposed between adjacent energy-magnifying coils 24. Each array in Fig.5 can comprise multiple LEDs or as few as one LED.

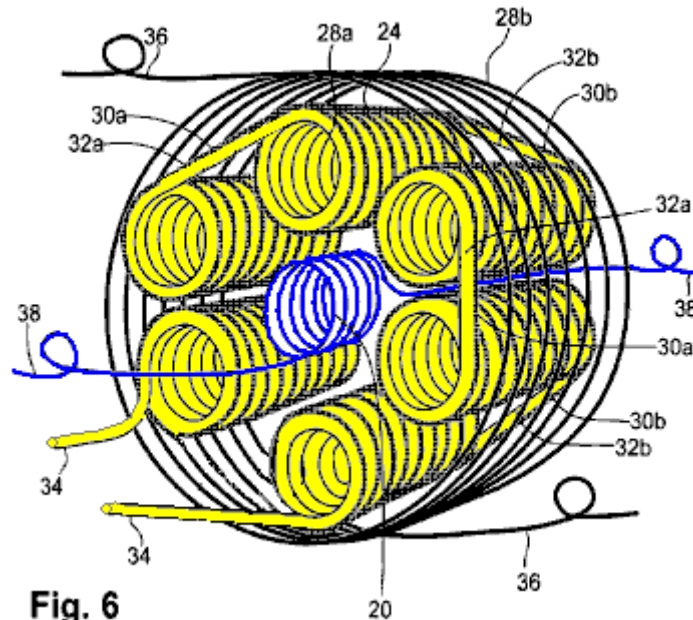

Fig. 6

Fig.6 provides a perspective view of an apparatus **15** having an arrangement of coils similar to the arrangement shown in **Fig.5**. In **Fig.6**, each energy-magnifying coil **24** comprises a helical coil of superconductive or photoconductive material in wire or ribbon (tape-like) form.

Whenever multiple energy-magnifying coils **24** are used, the respective directions of electron flow in them desirably occur in the same circular direction as viewed endwise. Thus, the flow of electrons in all the energy-magnifying coils **24** is clockwise during one phase of an oscillation cycle and counterclockwise during the other phase. The same principle applies to the flow of electrons in the output coils **28a**, **28b**. (But, in such an embodiment, the flow of electrons in the output coils **28a**, **28b**, is in the opposite direction to the electron flow in the energy-magnifying coils **24**). These relationships of electron flow in the coils during a particular phase of an oscillation cycle, are shown in **Fig.7**.

The energy-magnifying coils **24** desirably are connected together in series, using inter-coil connectors **30a**, **30b**, to maintain the same direction of electron flow, which can be clockwise or counterclockwise (as viewed from one end of such a coil). This direction of electron flow in a coil is termed the "handedness" of the coil. If the energy-magnifying coils **24** all have the same handedness, then the ends of adjacent energy-magnifying coils **24** are connected together in a head-to-foot manner progressively in one direction around the group of coils (not shown). ("Head" refers to the forward-facing end, and "foot" refers to the rearward-facing end of the apparatus in relation to the viewer). In this case, the inter-coil connectors **30a**, **30b**, must pass either completely through the apparatus or around the outside of the apparatus for its entire length, which reduces efficiency and can cause undesirable wear if the connectors are subjected to vibrations. A more desirable arrangement is depicted in **Fig.6**, in which short inter-coil connectors **30a**, cross directly head-to-head between one energy-magnifying coil **24** and an adjacent energy-magnifying coil **24**, and short inter-coil connectors **30b** cross over directly foot-to-foot in the next energy-magnifying coils **24**. In this configuration, the handedness of turns of the energy-magnifying coils **24** alternates from right-to-left to left-to-right in adjacent energy-magnifying coils **24**. In the same manner as a right-handed screw advances from head to foot as it is turned clockwise, and a left-handed screw moves in the opposite direction, clockwise electron flow in a right-handed coil advances from head to foot, and clockwise electron flow in a left-handed coil advances from foot to head.

The single-layered internal output coils **28a** in **Fig.6**, present the same situation in which these coils are connected in series. Desirably, the inter-coil connectors **32a** cross over directly from one internal output coil **28a** to the adjacent internal output coil **28a**, head-to-head and the inter-coil connectors **32b** cross over directly foot-to-foot from one internal output coil **28a** to the adjacent internal output coil **28a**. This same handedness convention generally applies to all series-connected internal output coils **28a** connected in this manner. The head-to-head inter-coil connectors **32a** and foot-to-foot inter-coil connectors **32b** for the internal output coils **28a**, need not coincide with the same respective connectors **30a**, **30b** for the energy-magnifying coils **24**.

In another embodiment (not shown), each internal output coil is two-layered, with both leads at either the head or foot. Such a configuration allows for short and direct connections between adjacent internal output coils. Multiple-layered internal output coils may be more efficient, but the extra layers of coiled wire increase the mass of the apparatus, which may be a concern in mobile applications. Multiple wire layers carrying high current may also result in overheating, which may require that some space be left between each internal output coil **28a** and its surrounding energy-magnifying coil **24** to accommodate one or more conduits of a coolant through the

apparatus (at a sacrifice of some efficiency). The coolant can be, for example, forced air (in the case of photoconductors or doped semiconductors) or liquefied cryogenic gas (in the case of superconductors).

Fig.6 also shows two external conductors **34** connected to respective internal output coils **28a**. Electrons flow through the conductors **34** and the internal output coils **28a** in series. In addition, two external conductors **36** are connected to respective ends of the external output coil **28b**, and two external conductors **38** are connected to respective ends of the sending coil **20**.

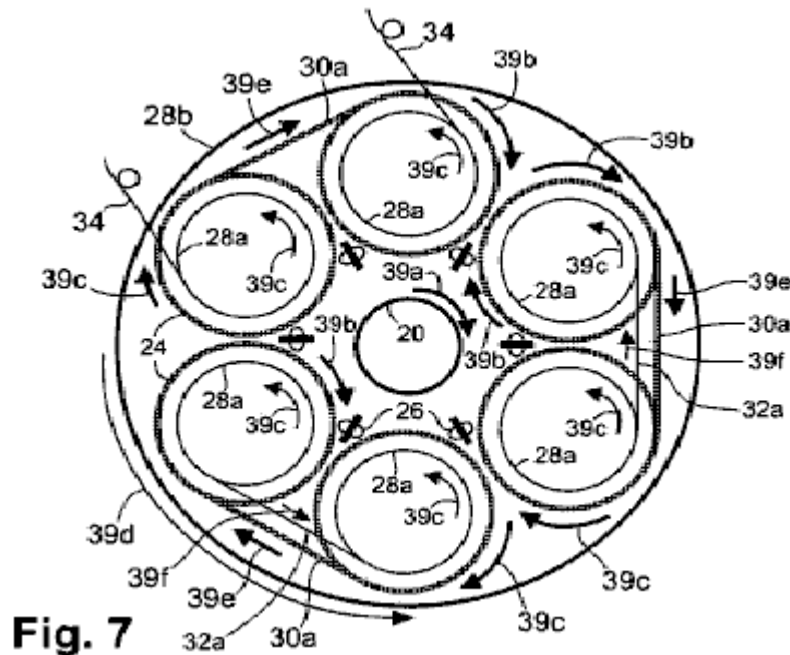

Fig.7 is a schematic end view of the apparatus of **Fig.6**, showing the relative direction of electron flow in the various coils and in the inter-coil connections described for single-layer coils. At a particular oscillation phase, the clockwise electron flow denoted by the arrow **39a** in the sending coil **20** induces clockwise electron flow **39b** in all the energy-magnifying coils **24**. The magnified radiation from the clockwise electron flow in the energy-magnifying coils **24**, induces counterclockwise electron flow in all the internal output coils **28a**, as indicated by the arrows **39c**. The counterclockwise electron flow, denoted by the arrow **39d**, in the external output coil **28b** is opposite in direction to the electron flow in the energy-magnifying coils **24**.

The electron flow in the inter-coil connectors **30a** extending between adjacent energy-magnifying coils **24** is indicated by the arrows **39e**, and the electron flow in the inter-coil connectors **32a** extending between adjacent internal output coils **28a** is indicated by the arrows **39f**. During the next oscillation phase, all the direction arrows shown in **Fig.7** reverse themselves.

Connecting the internal output coils **28a** together in series is advantageous if it is desired to maximise the output voltage from the apparatus **15**. Alternatively, the internal output coils **28a** can be connected together in parallel if it is desired to maximise the output electrical current from the apparatus **15** while minimising the output voltage. In this alternative configuration, all the internal output coils **28a** desirably are wound with the same handedness, with each coil **28a** having two respective leads. The leads at one end (e.g., the foot end) of the coils **28a** are connected to each other, and the leads at the other end (the head end) of the coils **28a** are connected to each other. The resulting parallel-coil system is connected in a conventional manner in other circuitry of the apparatus (not shown).

Further alternatively, the internal output coils **28a** can be connected together so as to provide more than one output circuit (so long as sufficient energy is produced for use as feedback to the sending coil **20** and for use in establishing favourable conditions for producing abundant low-mass electrons). Alternatively, the relative voltage(s) and current(s) of output power can be varied by changing the ratio of the number of turns in the energy-magnifying coils **24** to the number of turns in the internal output coils **28a**. Alternatively again, the energy-magnifying coils **24** can be employed in a separate manner to provide more than one energy-magnifying unit. Each unit can comprise one or more energy-magnifying coils that can serve its respective circuit of internal output coils.

The two conductors **36** connected to the external output coil **28b**, can be connected to the internal output coils **28a** or can be used (without being connected to the internal output coils **28a**) with only the external output coil **28b** to provide an independent output circuit (not shown). The two conductors **38** connected to the sending coil **20**,

are connected in the feed-back loop 46 such that electron flow in the sending coil 20 is in the same circular direction as in the internal output coils 28a.

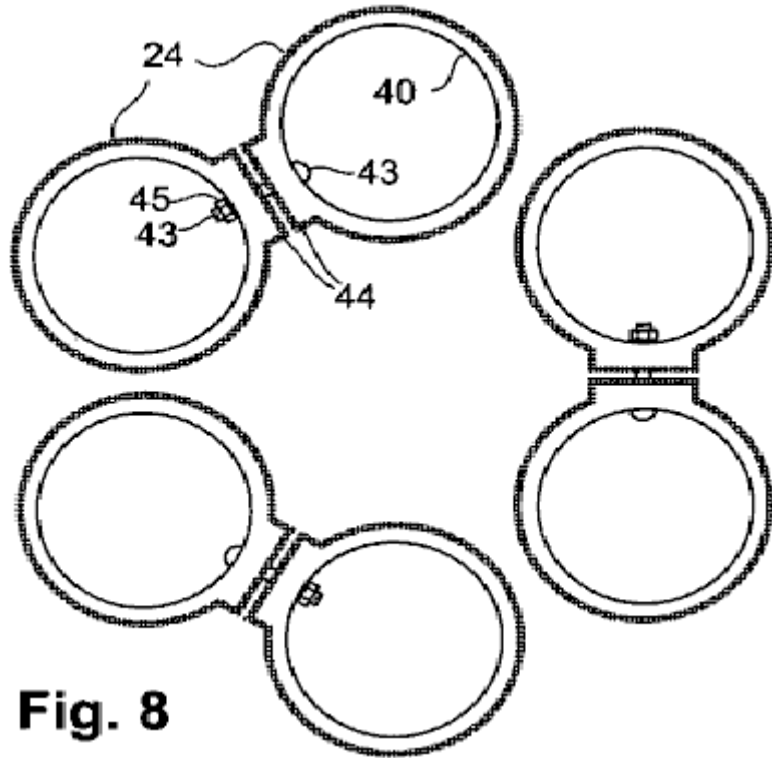

Fig. 8

Fig.8 depicts yet another embodiment of the apparatus 15, in which each energy magnifying coil 24 comprises a thin film or thick film of a polycrystalline or other suitable photoconductor deposited in a helical manner directly on to a tubular substrate 40 desirably made of ceramic or other suitable dielectric material. on each energy magnifying coil 24, the polycrystalline photoconductor is formed as a helical band on the outside of the tubular substrate 40. The helical band of photoconductor can include a thin film of metal embedded within it. In certain cases, inter-coil connections between adjacent energy magnifying coils 24 can be made by extending the deposited photoconductor from the helices to contact areas 44 situated at the ends of the tubular substrates 40 and extending toward contact areas 44 on adjacent tubular substrates 40. Electrical contact between adjacent energy magnifying coils 24 is made under moderate pressure via the contact areas 44, which are shown in **Fig.8**. To distinguish the individual contact areas 44, they are shown in a separated position before being pressed together to make contact. To maintain the integrity of the contact areas 44, the energy magnifying coils 24 can be held together in mutual proximity by any of various non-metallic fasteners to make continuous electrical contact between all of the photoconductive portions. For example, bolts 43 and nuts 45 made of a plastic such as nylon, or other dielectric material, can be used. Another variation is to maintain contact pressure of one coil to the next by means of spring clips. Thus, in one embodiment, the energy magnifying coils 24 are connected so as to be in endless contact with each other, with no capacitive break between them. The remainder of the apparatus can be constructed in the same manner as the photoconductor or doped-semiconductor embodiment described above, wherein the same attention to the direction of electron flow in respective coils is observed.

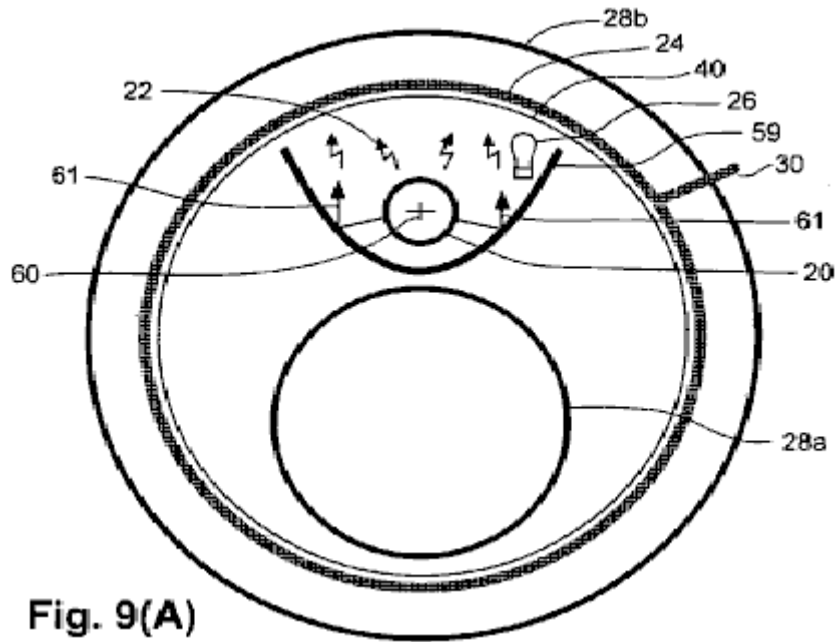

Fig. 9(A)

The coil configuration of yet another embodiment is shown in **Fig.9A** and **Fig.9B**. A tubular substrate **40**, supports a helical, thin film or thick film, dipole-type of energy-magnifying coil **24** that is nested inside and coaxial with a single external output coil **28b**. Nested inside the tubular substrate **40**, and with respective axes parallel to the axis of the tubular substrate **40**, are a sending coil **20** and an internal output coil **28a**. The sending coil **20** and the internal output coil **28a**, are positioned on opposite sides of a reflective metallic separator **59**. The separator **59** is substantially parabolic in cross-section throughout its axial extent, and is positioned so that the longitudinal edges are touching, or nearly touching, the tubular substrate **40**. The separator **59** can be composed of common, non-magnetic metal such as aluminium or magnesium. The sending coil **20** is positioned on the concave side of the separator **59**, with the axis of the sending coil **20** being positioned at the geometric focus **60** of the parabola and disposed parallel to the axis of the energy-magnifying coil **24**. The energy-magnifying coil **24** in this embodiment, comprises a thin film or thick film photoconductor formed helically on the tubular substrate **40**. A photoconduction exciter **26** is positioned inside the separator **59**. (The tubular substrate **40**, is made of a rigid material that is transparent to radiation produced by the photoconduction exciter **26**). All the other forms of the energy-magnifying coil **24** as described herein, including the superconducting form, can be employed in this embodiment.

The separator **59**, serves a double purpose. One purpose is to direct towards the energy-magnifying coil **24** the portion of the inductive-photon radiation **22** which is not otherwise directed towards the separator, as shown by the reflected-photon rays **61** in **Fig.6A**. (Reflection of these radiated photons does not change the directionality of the transverse force which these photons convey). Another purpose of the separator **59** is to serve as a shield to restrict the amount of inward radiation **18b** from the energy-magnifying coil **24** which is returned as a back-force to the sending coil **20**. The restricted back-force radiation is shown by the shaded area **63** in **Fig.9B**.

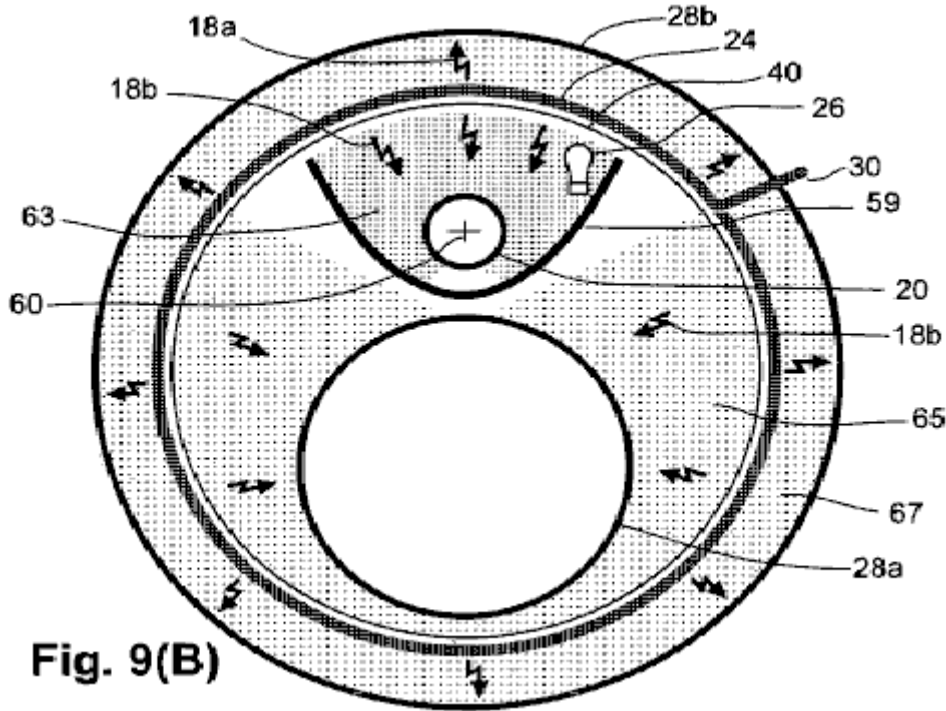

Fig. 9(B)

The portion of the inwardly directed, magnified inductive-photon radiation **18b** which is received by the internal output coil **28a**, is denoted by the shaded area **65**. The proportional amount of outwardly directed magnified radiation **18a** from the energy-magnifying coil **24** which is received by the external output coil **28b**, is shown by the shaded area **67**. The sum of the magnified radiation in the area **65** which reaches the external output coil **28b**, substantially exceeds the magnified radiation in the area **63** (the latter serving as a back-force on the sending coil **20**). This excess of utilised energy over the back-force energy, provides energy leverage. This embodiment also includes a starting mechanism, and initial power source for the photoconduction exciter, a work loop, and a feedback loop (not shown) as provided in the other embodiments described herein.

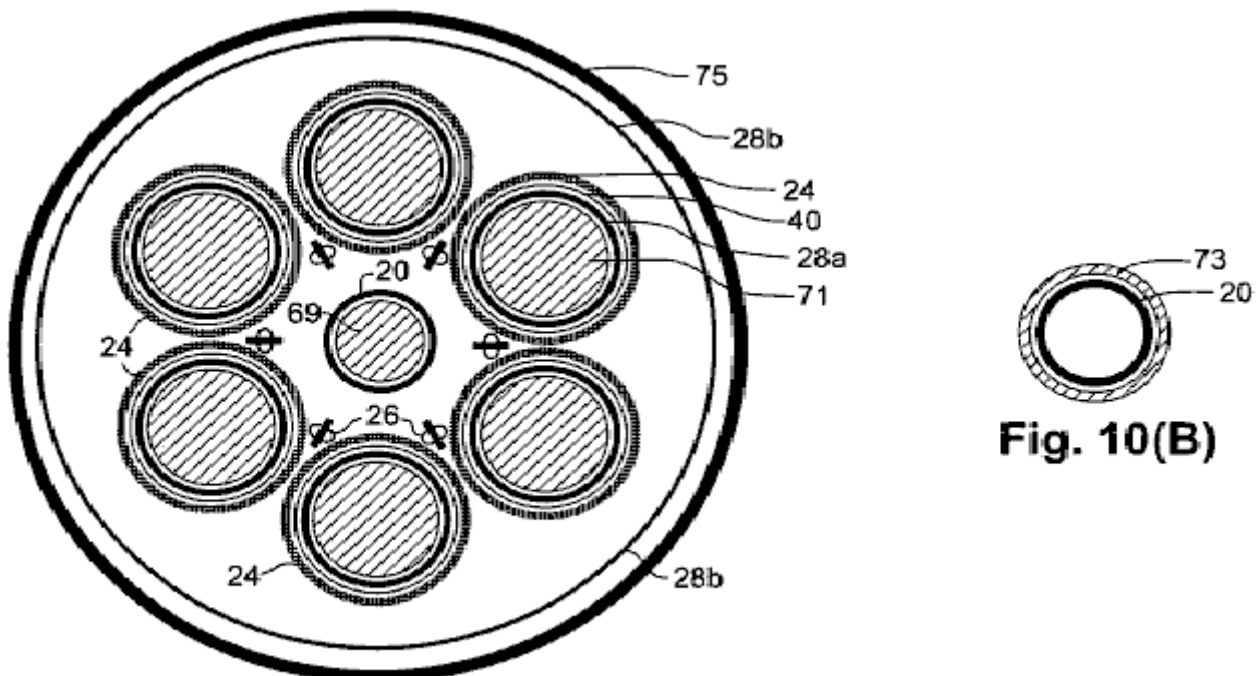

Fig. 10(A)

Fig. 10(B)

Certain features can be incorporated with any of the embodiments described herein, to add functional practicality. For example, referring to the schematic representation of a coil configuration shown in end view in **Fig. 10A**, a ferromagnetic core **69** can be placed inside the sending coil **20**, and ferromagnetic cores **71** can be placed inside respective internal output coils **28a**. These cores increase the inductance of the apparatus, which lowers the frequency of the electrical oscillations produced by the apparatus. Although increases in inductance can cause

the output voltage and current to be out of phase, the phase difference can be corrected by adding capacitance to the circuitry by conventional means. Also shown, is an external metal shield which completely surrounds the apparatus to block any radiation from the device that could interfere with radios, televisions, telephones, computers and other electronic devices. the shield can be comprised of any of various non-magnetic metals such as aluminium or magnesium.

An alternative means of increasing the inductance of the apparatus is shown in **Fig.10B**, which is a variation of the end view of just the sending coil **20** that is depicted in **Fig.10A**. In **Fig.10B**, a ferromagnetic sleeve **73** is placed coaxially around the sending coil **20**.

The respective dimensional ratios of various components generally remain similar with respect to each other for different apparatus sizes, except for the longitudinal dimension, which generally can be as short or as long as desired, up to some practical limit. The respective gauges of wires used in the sending coil **20** and the output coils **28a** and **28b**, are commensurate with the electric current carried by these wires, and the respective thickness of insulation (if used) on the wires is commensurate with the voltage.

The outside diameter of the internal output coils **28a** desirably is only slightly less than the inside diameter of the respective energy-magnifying coils **24**, as shown in **Fig.6**, **Fig.7** and **Fig.8**, thereby ensuring close proximity of each internal output coil **28a** with its respective energy-magnifying coil **24**. At a sacrifice in efficiency, the outside diameter of the internal output coils **28a** can be made smaller, to allow space for heat from the current-carrying wires to escape or be removed by a coolant such as forced air in the case of a photoconductor type or doped semiconductor type apparatus, or by a cryogenic liquefied gas in the case of a superconductor type apparatus.

Also, desirably, the external output coil **28b** is connected in series with the internal output coils **28a** to maximise the output voltage from the apparatus **15** and to minimise heat produced by electric currents in the apparatus. The output voltage can be stepped down and the output electric current stepped up to normal operating ranges by using a transformer, wherein the primary of the transformer would comprise the load in the work loop **48**.

As discussed above, each energy-magnifying coil **24** can comprise a photoconductor or doped semiconductor formed as a helical pattern on a respective thin-walled tubular substrate provided with extended, raised contact surfaces at each end. The energy-magnifying coils **24** desirably are connected electrically (rather than capacitatively) to each other in series at the raised contact surfaces. The photoconductive coils desirably are coated using clear varnish or enamel to provide electrical insulation and to protect the photoconductors from oxidation and weathering.

Where the low-mass photoconducting electrons in the energy-magnifying coils **24** are present in a concentration which is insufficient for capturing most of the inductive-photon radiation from the sending coil **20**, each energy-magnifying coil desirably includes a thin metallic band. The metal desirably is in intimate contact with the low-mass-electron carrier. the metal can be on the exterior of a doped semiconductor, or it can be embedded in a photoconductor band of the coil to capture the inductive radiation and set up an electric field which, in turn, assists in accelerating the low-mass electrons. In the photoconductive embodiment, the photoconductive material desirably is disposed all around the metallic band so that the low-mass electrons are conducted on the outer side as well as the inner side and edges of the photoconductive band on the portion or portions which are exposed to illumination on the outside. The width of the metal band desirably is sufficient to capture as much of the inductive-photon radiation from the sending coil as is practical, since gaps between turns of the metal band in the energy-magnifying coil permit the sending coil's inductive radiation to pass through to the internal output coil. Since the sending coil's radiation is a half-cycle out of phase with the inductive radiation from the low-mass electrons, all the sending coil radiation which reaches the output coil, reduces the output efficiency of the apparatus.

Appropriate photoconductive materials (e.g. cadmium sulphide, cadmium selenide) for forming the energy-magnifying coils **24** are commercially available. The photoconductive material can be a single material or a mixture of materials, and can be formed by, for example, sputtering. A mixture of cadmium sulphide and cadmium selenide can be adjusted optimally to yield energy-magnifying coils exhibiting maximal energy-magnifying factors at a peak wavelength matching the brightest photoconduction excitors **26** which are available.

With respect to the photoconduction excitors **26**, photo-excitation of the energy-magnifying coils **24** can be provided by one or more LEDs, either surface-emitting or edge-emitting, for example, selected to produce an output wavelength matched to the peak photoconduction wavelength of the energy-magnifying coils **24**. In the embodiment of **Fig.7** and **Fig.10A**, individual LEDs **26** are positioned in linear arrays mounted back-to-back on respective mounting bars. The assembled mounting bars with LEDs are placed in the gaps between adjacent energy-magnifying coils **24** to illuminate at least the sides of the respective energy-magnifying coils **24** which receive inductive-photon radiation from the sending coil **20**. LEDs are advantageous compared to incandescent lamps because LEDs produce more light with less heat and have a much longer operational lifetime than

incandescent lamps. LEDs are also preferred because of their small size which facilitates fitting a large number of them into the relatively small space between adjacent energy-magnifying coils **24**.

Whereas the invention has been described in connection with several representative embodiments, the invention is not limited to those embodiments. On the contrary, the invention is intended to encompass all modifications, alternatives and equivalents as may be included within the spirit and scope of the invention, as defined by the appended claims.

References Cited in the Text

Helmholtz, H., 1847, *Über die Erhaltung der Kraft*, G.A.Reimer, Berlin. *On the Conservation of Force*, English translation with Appendices of 1881, Wesleyan university Press, Middletown Conn., 1971.

Leimer, E., 1915, "Über Radiumantennen", *Elektrotechnische Zeitschrift*, Heft 8, Feb. 25, 1915. English translation: "On Radium Antennae" *The Electrician*, Apr. 21 1916, and "Radium and Aerials" *Scientific American*, Supplement No. 2127, Oct. 7, 1916.

Anon, 1919a, "Youthful Seattle Inventor and his Invention" (photos and captions), *Seattle Post-Intelligencer*, Dec. 17, 1919.

Anon., 1919b, "Youth's Revolutionary invention is Backed by Professor - Hubbard's New Energy No Fake, Says Seattle College Man", *Seattle Post-Intelligencer*, Dec. 17, 1919,

Anon. 1920a, "Hubbard Coil Runs Boat on Portage Bay Ten Knots an Hour, Auto Test Next", *Seattle Post-Intelligencer*, Jul. 29, 1920.

Anon., 1920b, "Drives Boat with New Electric Generator" (photos and captions), *Seattle Post-Intelligencer*, Jul. 29, 1920.

Anon., 1928a, "Noted Flyers Try Out New Motor at Selfridge Field" (photo), *Detroit Free Press*, Feb. 25, 1928.

Anon., 1928b, "Fuelless Motor Shown; Gets Current From Air", *Detroit Free Press*, Feb. 25, 1928.

White, H. C., 1928c, "Lindbergh Tries Motor Earth Runs", *Detroit Free Press*, Feb. 25, 1928.

Anon., 1928d, "Fuelless Motor Impresses Experts", *New York Times*, Feb. 26, 1928.

Anon., 1928e, "No-Fuel Motor Finds Backers", *Detroit News*, Feb. 26, 1928.

Anon., 1928f, "Fuelless Motor Is A Generator", *New York Times*, Feb. 27, 1928.

Anon., 1928g, "Fuelless Motor Ends 2-year Task", *Seattle Post-Intelligencer*, Feb. 27, 1928.

Bermann, R. B., 1928 h, "Hubbard Believes Mystery Motor Based Upon His Own Invention", *Seattle Post-Intelligencer*, Feb. 27, 1928.

Ampere, A. M., 1820, "Memoire", *Annales de Chimie et de Physique*.

Ampere, A. M., 1825, "Memoire", *Annales de Chimie et de Physique*.

Weber, W., 1846, *Elektrodynamische Maassbestimmungen*, Weidmann'sche Buchhandlung, Leipzig.

Gauss, C. F., 1835, unpublished notes originally published posthumously in 1865 as "Grundgesetz Für Alle Wechselwirkungen Galvanischer Ströme" in *Werke*, Vol. 5, pp. 616-620; the correspondence from Gauss to Wilhelm Weber (1845) is on pp. 627-629.

Maxwell, J. C., 1873, *A Treatise on Electricity and Magnetism*, Clarendon Press, Oxford.

Larmor, J., 1897, "On the Theory of Magnetic Influence of Spectra; and on the Radiation From Moving Ions", *Phil. Mag* LXIII:503-512.

Larmor, J., 1900, *Aether and Matter*, Cambridge University Press.

Rutherford, E., 1911, *Phil. Mag.* XXI:669.

- Planck, M., 1911, *Verh. D. Deutsch. Phys. Ges.* XIII:138
- Bohr, N., Kramers, H. A., and Slater, J. C., 1924, *Phil. Mag.* XLVII:785
- Whittaker, E., 1951, *A History of the Theories of Aether and Electricity*, Thos. Nelson & Sons, London; reprinted by Dover, New York, 1989.
- Shpenkov, G. P., and Kreidik, L. G., "Microwave Background Radiation of Hydrogen Atoms", *Revista Ceencias Exastas e Naturais* 4, n.1, pp. 9-18, January/June 2002.
- Fowler, W. A., 1983, "Experimental and Theoretical Nuclear Astrophysics; the Quest for the Origin of the Elements", Nobel Lecture, Dec. 8, 1983.
- Tifft, W. G., 1976, "Discrete States of Redshift and Galaxy Dynamics I", *Astrophysical Journal* 206:38-56.
- Tifft, W. G., 1977, "Discrete States of Redshift and Galaxy Dynamics I I: Systems of Galaxies", *Astrophysical Journal* 211:31-46; and "Discrete States of Redshift and Galaxy Dynamics I I I: Abnormal Galaxies", *Astrophysical Journal* 211:377-391.
- Compton, A. H. and Allison, S. K., 1935, "X-Rays in Theory and Experiment" 2nd Ed., Van Nostrand, New York.
- Pops, H., 1997, "The Metallurgy of Copper Wire", *Innovations*, Dec. 1997 (Copper Development Assoc.).
- Lapp, R. E. and Andrews, H. L., 1954, *Nuclear Radiation Physics*, Prentice-Hall, Englewood Cliffs, N.J.
- Bardeen, J., 1942, "Theory of Superconductivity" (abstr.), *Phys. Rev.* 59:298.
- Dehmelt, H. G., 1989, "Experiments with an Isolated Subatomic Particle at Rest", Nobel Lecture, Dec. 8, 1989.
- File, J. and Mills, R. G., 1963, "Observation of Persistent Current in a Superconducting Solenoid", *Phys. Rev. Lett.* 10(3), Feb. 1, 1963.

ALTERNATING CURRENT GENERATOR

This is a reworded excerpt from this patent which shows a high-efficiency electrical generator of alternating current. It is stated that this generator design is not affected by Lenz's law and the experimental results showed a 13,713% improvement over conventional power output.

ABSTRACT

An alternating current electrical generator creates three different and distinct magnetic fields between wound coil elements and rotating magnets, two fields of which are induced fields caused by magnet rotation. A plurality of magnets are positioned such that they extend outwardly from a rotating shaft. The magnets are circumferentially spaced around the shaft such that the north polar end of one magnet follows the south polar end of the next magnet or such that the polar end of one magnet follows a magnet with the same polar end. A plurality of stationary coil elements are positioned in spaced relation to the magnets. The coil elements each have electrical windings and metal cores which extend the lengths of the coil elements. The magnets rotate in spaced relation to the ends of the coil elements in such a way that the magnets' flux lines cut the cores located at the centre of each of the coil elements. This induces alternating electric current that oscillates back and forth along the lengths of the cores. This oscillating current creates an expanding and collapsing set of magnetic flux lines which expand and contract through every inch of the coil element's windings. This expanding and collapsing magnetic field induces an expanding and collapsing magnetic field and an alternating electric field in the coil elements.

US Patent References:

4009406	Feb, 1977	Inariba.
4823038	Apr, 1989	Mizutani et al.
5696419	Dec, 1997	Rakestraw et al.
5821710	Oct, 1998	Masuzawa et al.
5973436	Oct, 1999	Mitcham.
6069431	May, 2000	Satoh et al.
6373161	Apr, 2002	Khalaf.
6462451	Oct, 2002	Kimura et al.
6541877	Apr, 2003	Kim et al.
6717313	Apr, 2004	Bae.

BACKGROUND OF THE INVENTION

Alternating current generators are rotating devices which convert mechanical energy into electrical energy. To generate an electromotive force by mechanical motion, there must be movement between an electric coil and a magnetic field in a manner that will cause a change in the flux that passes through the coil. Fundamentally, the induced electromotive force is brought about by a change in the flux passing through the coil.

The use of electromagnets, magnets and magnet components in generators to create the magnetic field and its subsequent effect on electric coils to ultimately generate electric current is well known. Such magnetic generators operate by using the repelling forces created by the effect of changing polarities of both permanent and electromagnets. For instance, there are electrical generating devices which employ electromagnets which are fixed in position and which induce current by being selectively energised, as iron or other magnetic metal discs, bars, or similar elements are rotated at or around the magnets. Other systems employ electromagnet or permanent magnets which are rotated, by various means, in relation to iron cores or coils, inducing an alternating electrical current within the coils.

However, prior alternating current generators which employ rotating magnet systems are inefficient and generally fail to deliver adequate current, in relation to the mechanical effort applied.

SUMMARY OF THE INVENTION

It is thus an object of the present invention to address the limitations and disadvantages of prior alternating electric current generators.

It is an object of the present invention to provide an alternating current generator which generates a substantial amount of electrical current efficiently and effectively.

It is a further object of the present invention to provide an alternating current generator which employs rotating magnets to induce increased alternating electrical current within the iron cores of electrical coils.

It is still another object of the present invention to provide an alternating current generator which can be simply and readily manufactured and be operated with high efficiency.

These and other objects are obtained by the present invention, an alternating current electrical generator which creates three different and distinct magnetic fields between wound coil elements and rotating magnets, two fields of which are induced fields caused by magnet rotation. A plurality of magnets are positioned such that they extend outwardly from a rotating shaft. The magnets are circumferentially spaced around the shaft such that the north polar end of one magnet follows the south polar end of the next magnet or such that the polar end of one magnet follows a magnet with the same polar end. A plurality of stationary coil elements are positioned in spaced relation to the magnets. The coil elements each have electrical windings and metal cores which extend the lengths of the coil elements. The magnets rotate in spaced relation to the ends of the coil elements in such a way that the magnets' flux lines cut the cores located at the centre of each of the coil elements. This induces alternating electric current that oscillates back and forth along the lengths of the cores. This oscillating current creates an expanding and collapsing set of magnetic flux lines which expand and contract through every inch of the coil element's windings. This expanding and collapsing magnetic field induces an expanding and collapsing magnetic field and an alternating electric field in the coil elements.

The novel features which are considered as characteristic of the invention are set forth in particular in the appended claims. The invention itself, however, both as to its design, construction, and use, together with additional features and advantages thereof, are best understood upon review of the following detailed description with reference to the accompanying drawings.

BRIEF DESCRIPTION OF THE DRAWINGS

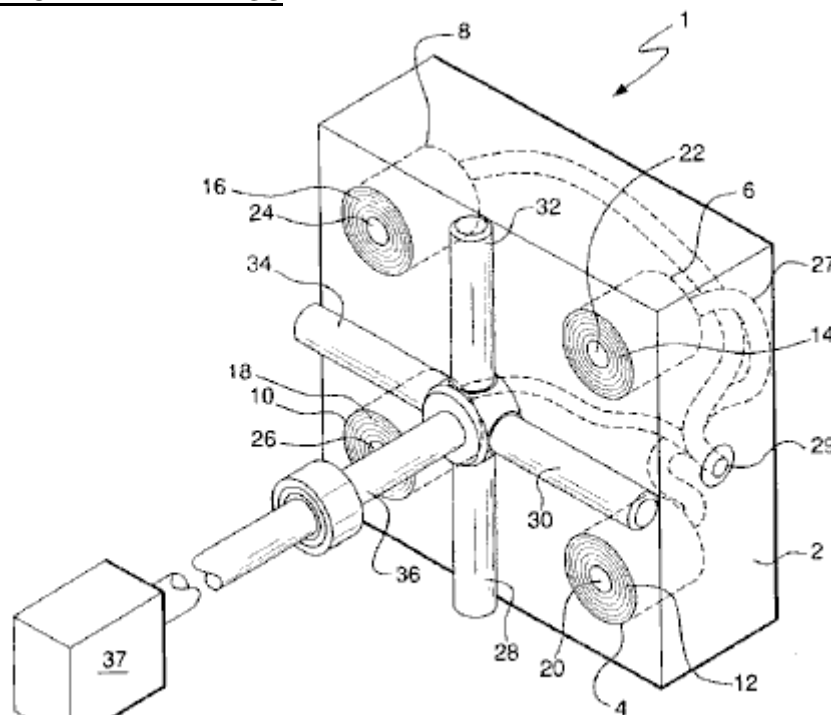

FIG. 1

Fig.1 is an isometric representation of keys components of the present invention.

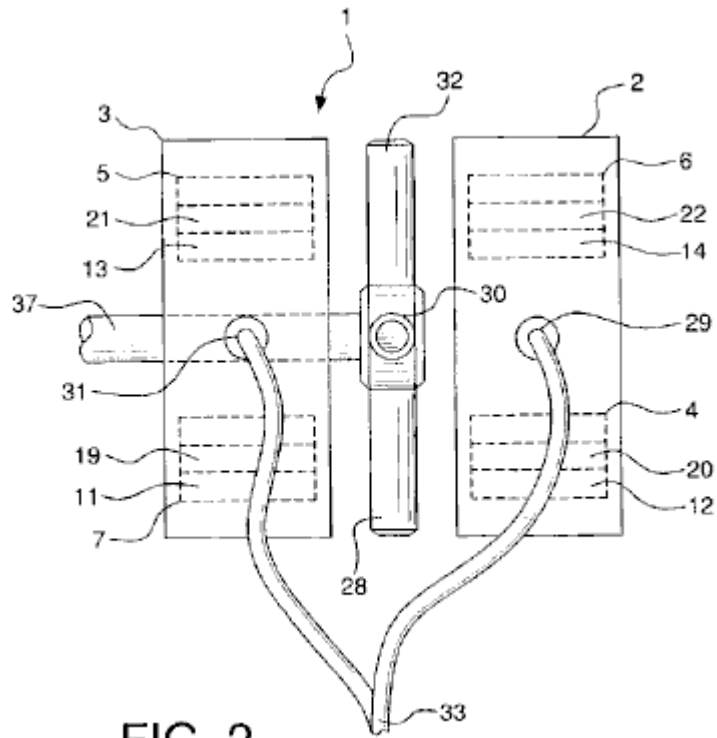

FIG. 2

Fig.2 is a side view representation of the present invention showing the two housed sets of coil elements and their relationship with the magnets.

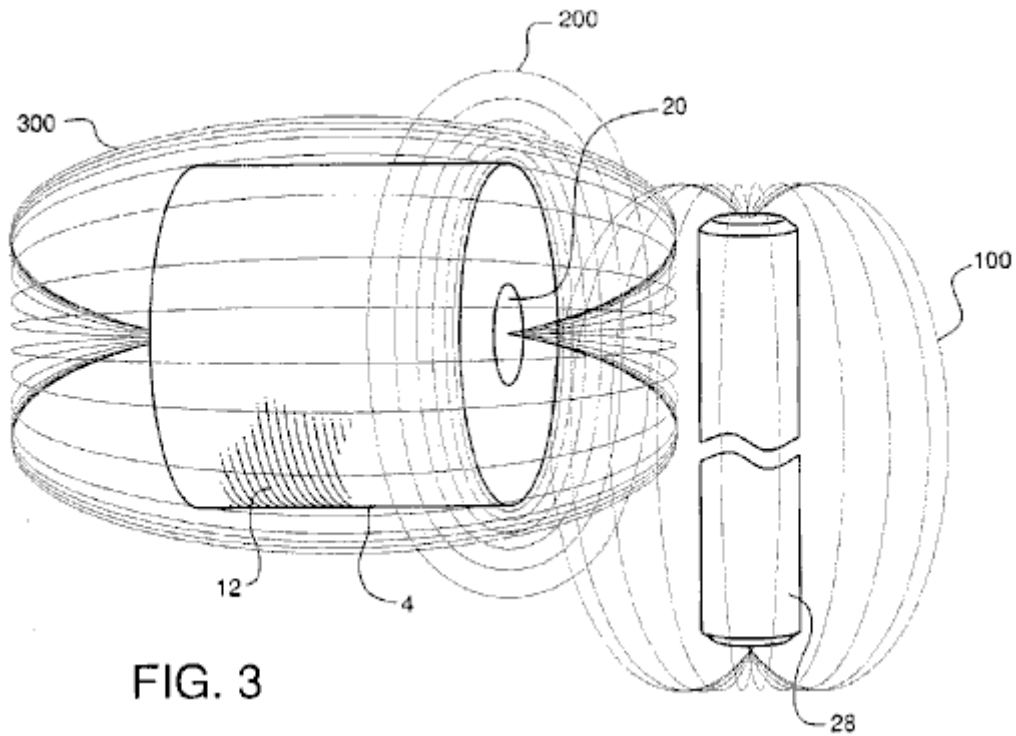

FIG. 3

Fig.3 is an explanatory view, showing the generation of flux lines which forms the basis for the operation of the present invention.

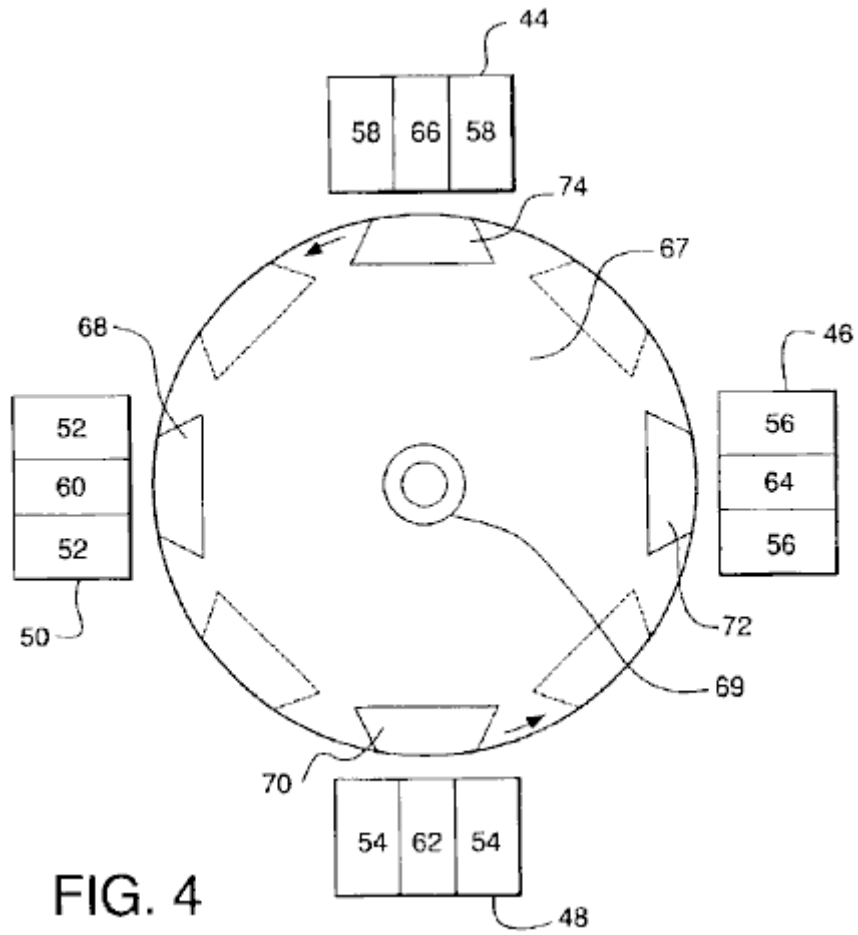

FIG. 4

Fig.4 is an alternate embodiment of the present invention.

DETAILED DESCRIPTION OF THE INVENTION

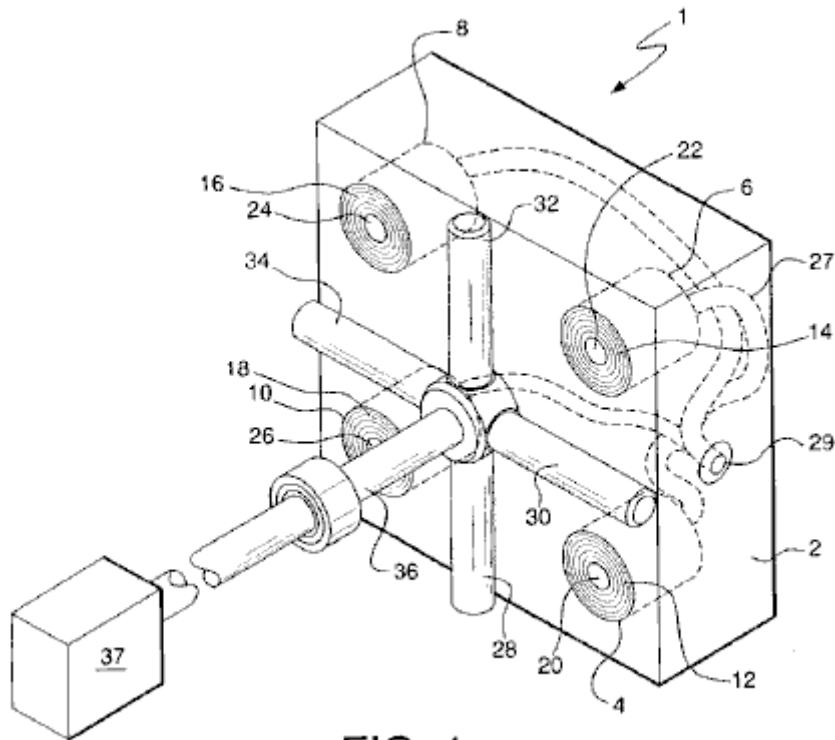
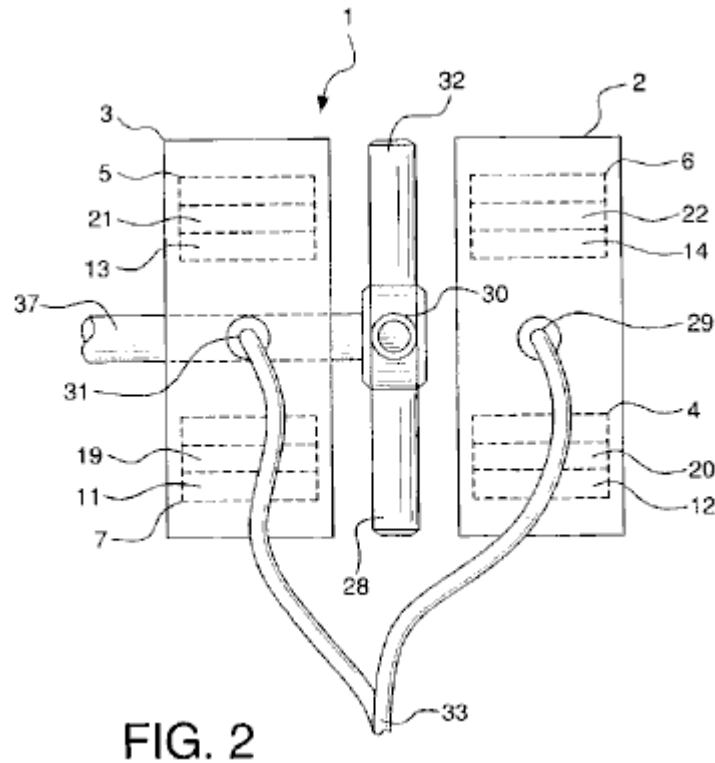

FIG. 1

Fig.1 and **Fig.2** show a clear depiction of the components of alternating current generator 1 of the subject invention. Generator 1 comprises housings 2 and 3. For simplicity purposes and ease of understanding, only housing 2 is shown in **Fig.1**. It must be understood, however, that generator 1 of the present invention is configured for use with both housings 2 and 3. Housing 2 contains coil elements 4, 6, 8 and 10. Each coil element comprises multiple windings 12, 14, 16, and 18, respectively, wound around inner steel or similar metal cores 20, 22, 24, and 26, respectively. Each steel core extends the full length and directly through each of the coil elements. Coil elements 4, 6, 8, and 10 are mounted within housing 2, such that the end surfaces of the coil elements and the ends of cores 20, 22, 24, and 26 are positioned flush with the external surface of housing 2.



Housing 3 also contains four coil elements positioned identically as has been described with regard to housing 2. Two of these coil elements 5 and 7 are shown in **Fig.2**. Coil element 5 has multiple windings 13 and centre core 21 and coil element 7 has multiple windings 11 and centre core 21.

Magnets 28, 30, 32, and 34 are secured to shaft 36, which is configured to be rotated by conventional power source 37, such as a diesel engine, turbine, etc. Magnets 28, 30, 31, and 32 all have ends with outwardly extending polarities. Magnets 28, 30, 32, and 34 are positioned in spaced relation to the ends of exposed cores 20, 22, 24 and 26 of coil elements 4, 6, 8, and 10 and in spaced relation to the ends of the four exposed cores in the four coil elements located in housing 3, cores 19 and 21 being shown in **Fig.2**. All magnets are equidistantly spaced on and around shaft 36, such that the outwardly extending pole of one magnet circumferentially follows the outwardly extending pole of the next magnet. The north polar end of one magnet may follow the south polar end of the next magnet or the polar end of one magnet may follow a magnet with the same polar end.

While four magnets and four cores are shown, it is contemplated that additional magnets and cores could be employed in the generator. Also, while permanent magnets are shown in the drawings, electromagnets could also be used, as they produce the same magnetic flux.

Alternating electrical current is generated when power source 37 rotates shaft 36, thus causing rotation of magnets 28, 30, 32, and 34 in spaced, adjacent relation to the ends of cores 20, 22, 24, and 26 of coil elements 4, 6, 8, and 10, and in spaced, adjacent relation to the ends of cores 19 and 21 of coil elements 7 and 5 and the ends of the cores of the other two similarly aligned coil elements in housing 3. The current which is generated is transmitted through electrical conductive wiring 27, which merges at connection points 29 in housing 2 and 31 in housing 3, for the consolidated transmission at connection point 33 of the electricity produced.

As best represented in **Fig.2**, when magnet 28 is rotated in space relation to the end of core 20 of coil element 4, flux lines 100 of the magnet cut the core at the centre of the coil element. This induces an alternating electrical current that oscillates back and forth along the length of core 20. This oscillating current creates an expanding and collapsing set of magnetic flux lines 200 which expand and contract through every inch of coil windings 12. Expanding and collapsing field 200 induces an alternating electric field in coil element 4 which is accompanied by

an expanding and collapsing magnetic field **300**. It is noted, significantly, that none of the magnetic field lines **100**, **200** and **300**, act in a negative fashion or in an opposing action. This allows the subject invention to overcome the limitations of Lenz's law, which states that whenever there is a change in magnetic flux in a circuit, an induced electromotive force is set-up tending to produce a current in a direction which will oppose the flux change.

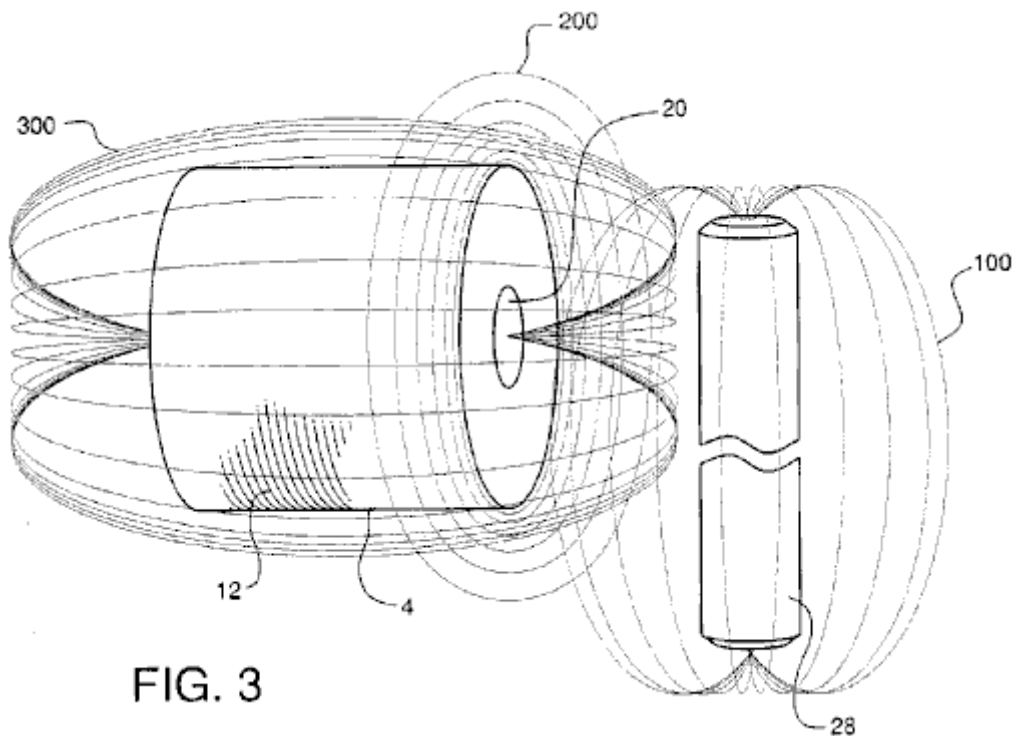

FIG. 3

Fig.3 illustrates an alternate embodiment of the invention to that which is shown in **Fig.1**. As shown in **Fig.3**, coil element **44** with outer windings **58** and inner steel core **66**, coil element **46** with windings **56** and core **64**, coil element **48** with windings **54** and core **62**, and coil element **50** with outer windings **52** and core **60** are positioned adjacent to rotor **67**, which is mounted on shaft **69**. Magnets **68** and **72** are mounted on rotor **67** such that the north poles of the magnets are positioned in spaced relation to coil elements **44**, **46**, **48** and **50**. Magnets **70** and **74** are mounted on rotor **67** such that the south poles of the magnets are also positioned in spaced relation to coil elements **44**, **46**, **48**, and **50**. All magnets are fixedly mounted on rotor **67** such that a north pole of one magnet circumferentially follows a south pole of the next magnet in line. The contemplated gap between the magnets and coil element cones is approximately 0.0001 of an inch, although the scope and use of the invention should not be deemed restricted to this distance.

As in the prior embodiment, rotation of magnets **68**, **70**, **72**, and **74**, by rotation of shaft **69** and hence rotor **67**, causes the flux lines of the magnets to cut cores **60**, **62**, **64**, and **66** of coil elements **44**, **46**, **48**, and **50**, eventually resulting in the output of electrical current as previously described.

It is noted that the larger the diameter of rotor **67**, the more coil elements can be positioned around the rotor. The greater the number of coil elements, the slower rotor **67** needs to rotate; however, there is a power loss in so doing. In addition, while rotor **67** is shown as being circular, it may be as square in shape or formed of as other appropriate multi-sided configurations.

This unique way of generating electricity allows generation of more electrical power, e.g. anywhere in the range of 4 to 137 times more power, than prior, conventional means. It also has the advantage of obtaining unity power with very little effort.

As evidence of such power gains, reference is made to the below outlined experimental outputs from coils and magnets which produced electric power the conventional way compared with the subject invention. The conventional way of generating power, for purpose of the following experimental outputs, as referenced herein, is accomplished by cutting the wires, not the cores, of the coil's windings with the magnet's flux.

In this regard, proof is also provided that the herein described method of generating electrical power is not affected by Lenz's Law, by reference to the readings obtained by the conventional methods as the rpm and size of the coil increase. With conventional methods, the values do not change linearly, but are less because Lenz's Law restricts the outputs from increasing proportionally to the speed and size of the coil. In comparison, however,

in the method of producing power of the subject invention, there is an increase in the readings of V (voltage), I (current), and P (power) which are actually larger than anticipated.

It is also noted that, just like a transformer, when the number of turns ratio is increased, V increases and I decreases, which is exactly what is seen at the various rpm readings for the different size coils. However, they do not increase or decrease proportionally.

Thus, this presents the ideal model for producing electrical power that corresponds to the general law that states that as the speed increases, the voltage will increase proportionally, through the equation:

$V = q \text{ (charge)} \times v \text{ (velocity)} \times B \text{ (magnetic field strength)}$. This also holds true for a coil, in that transformers increase proportionally to the turns ratio.

With reference to the voltage outputs for each of the coils, 1100T, 2200T and 5500T, it is seen that they are consistent with the types of voltage outputs for a transformer action. That is to say, as the turns ratio goes up in a transformer so does the voltage. Since the increases in voltage between the number of turns is not exactly 2 to 5 times, one can pick any one of the coils and assume it is accurate and adjust the other coils accordingly. Thus, by fixing the 1100T coil, the other coils become 2837T and 5896T respectively. By fixing the 2200T coil, the other coils become 853T and 4572T respectively. And by fixing the 5500T coil, the other coils become 1026T and 2646T respectively. Also, if the adjustments are made as described here, i.e. that the coils are bigger than originally thought, and they are applied to the voltages for the conventional method of generating power, the voltages do not increase proportionally but are actually smaller than they are supposed to be, additional proof that Lenz's Law has application to conventional generators, but not to this invention.

The proportional changes in the voltage relative to speed can also be seen. Thus, considering the 350 RPM speed as accurate, the 1200 RPM and 1300 RPM speeds will adjust to 906 RPM and 1379 RPM respectively. Considering the 1200 RPM speed as accurate, the 350 RPM and 1300 RPM speed becomes 464 RPM and 1826 RPM respectively. And finally, considering the 1300 RPM speed as accurate, the 350 RPM and 1200 RPM speeds become 330 RPM and 854 RPM respectively.

It is noted that in using the various RPM readings based upon the above, it is seen that, in the conventional way of generating power, there are losses associated with the measured values. The calculated values again show the application of Lenz's Law in the conventional way of generating power, but not to this invention. In fact, whether or not there is an adjustment of RPM speed or coil size, the power generation of this invention is in no way affected by Lenz's Law.

Since Lenz's Law has no effect in this generator, it can be assumed that the voltages increase proportionally to the speed of the magnets rotation. Therefore, one can extrapolate the expected voltages at 1800 RPM, the speed necessary to create 60 Hz. With regard to this generator, for each of the three coils from the 350 RPM, 1200 RPM and 1300 RPM speeds, the following results (values are based on one coil/magnet.):

1. At assumed 350 RPM the voltages range as follows:

- A. 5.863v @1100T
- B. 15.12v @2200T
- C. 31.42v @5500T

2. At assumed 1200 RPM the voltages range as follows:

- A. 4.425v @1100T
- B. 11.295v @2200T
- C. 16.845v @5500T

3. At assumed 1300 RPM the voltages range as follows:

- A. 6.217v @1100T
- B. 10.716v @2200T
- C. 17.668v @5500T

The reason the current is not changing linearly as the laws of physics imply from transformers, i.e. as voltage goes up based on the number of turns, the current goes down proportionally to the voltage gain, is due to the fact

that the inductive reactance is also going up. See the following chart for the inductive reactances for each coil at each speed.

Impedance (Z) or inductive reactance (X(L)) for a circuit with only a coil in it is the AC voltage divided by the AC current, and the inductance (L) is $Z/2 \times \pi \times F$ (frequency). For a circuit with a resistor and a coil $Z = \text{square root of } (R \text{ (resistance) squared} + X(L) \text{ squared})$.

The following is the chart of impedance Z for all coil sizes at all speeds for the conventional method of generating power and the method of generating power with this invention:

Where:

“T” stands for Turns,

“CM” stands for Conventional Method and

“SI” stands for Subject Invention:

(1) For 350 RPM for 1100T, 2200T and 5500T coils,

1. (a) CM: $0.57\text{v} / 56.6 \text{ mA} = 10.021 \text{ ohms} = Z$
(b) SI: $1.14\text{v} / 106.6 \text{ mA} = 10.694 \text{ ohms} = Z$
2. (a) CM: $0.93\text{v} / 32.4 \text{ mA} = 28.704 \text{ ohms} = Z$
(b) SI: $2.94\text{v} / 70.1 \text{ mA} = 41.94 \text{ ohms} = Z$
3. (a) CM: $2.09\text{v} / 17.3 \text{ mA} = 120.81 \text{ ohms} = Z$
(b) SI: $6.11\text{v} / 37.9 \text{ mA} = 161.21 \text{ ohms} = Z$

(2) For 1200 RPM for 1100T, 2200T and 5500T coils:

1. (a) CM: $1.45\text{v} / 60.2 \text{ mA} = 23.387 \text{ ohms} = Z$
(b) SI: $2.95\text{v} / 141 \text{ mA} = 20.922 \text{ ohms} = Z$
2. (a) CM: $3.225\text{v} / 36.2 \text{ mA} = 89.088 \text{ ohms} = Z$
(b) SI: $7.53\text{v} / 73.5 \text{ mA} = 102.449 \text{ ohms} = Z$
3. (a) CM: $4.81\text{v} / 17 \text{ mA} = 282.941 \text{ ohms} = Z$
(b) SI: $11.23\text{v} / 31.4 \text{ mA} = 357.643 \text{ ohms} = Z$

(3) For 1300 RPM for 1100T, 2200T and 5500T coils:

1. (a) CM: $1.6\text{v} / 83 \text{ mA} = 19.27 \text{ ohms} = Z$
(b) SI: $4.59\text{v} / 157 \text{ mA} = 29.236 \text{ ohms} = Z$
2. (a) CM: $2.75\text{v} / 50.4 \text{ mA} = 54.455 \text{ ohms} = Z$
(b) SI: $7.74\text{v} / 88.5 \text{ mA} = 87.458 \text{ ohms} = Z$
3. (a) CM: $5.061\text{v} / 17.3 \text{ mA} = 292.543 \text{ ohms} = Z$
(b) SI: $12.76\text{v} / 36.4 \text{ mA} = 350.549 \text{ ohms} = Z$

(4) For 400 RPM for 2300T coil with 24 gauge wire and 0.5" core:

- (a) CM: $0.15\text{v} / 3.7 \text{ mA} = 40.541 \text{ ohms} = Z$
(b) SI: $2.45\text{v} / 26.2 \text{ mA} = 93.511 \text{ ohms} = Z$

(5) For 1200 RPM for 2300T coil with 24 gauge wire and 0.5" core:

- (a) CM: $0.37\text{v} / 2.7 \text{ mA} = 137.037 \text{ ohms} = Z$
(b) SI: $4.1\text{v} / 10.3 \text{ mA} = 398.058 \text{ ohms} = Z$

(6) For 1400 RPM for 2300T coil with 24 gauge wire and 0.5" core:

- (a) CM: $0.58\text{v} / 2.4 \text{ mA} = 241.667 \text{ ohms} = Z$
- (b) SI: $8.3\text{v} / 7.8 \text{ mA} = 1065.385 \text{ ohms} = Z$

(7) For 400 RPM for 2300T coil with 24 gauge wire and 0.75" core:

- (a) CM: $0.23\text{v} / 4.2 \text{ mA} = 54.762 \text{ ohms} = Z$
- (b) SI: $0.37\text{v} / 7.2 \text{ mA} = 51.389 \text{ ohms} = Z$

(8) For 1200 RPM for 2300T coil with 24 gauge wire and 0.75" core:

- (a) CM: $0.79\text{v} / 3.4 \text{ mA} = 232.353 \text{ ohms} = Z$
- (b) SI: $0.43\text{v} / 6.9 \text{ mA} = 207.246 \text{ ohms} = Z$

(9) For 1400 RPM for 2300T coil with 24 gauge wire and 0.75" core:

- (a) CM: $0.79\text{v} / 3.21 \text{ A} = 246.875 \text{ ohms} = Z$
- (b) SI: $2.1\text{v} / 2.7 \text{ mA} = 777.778 \text{ ohms} = Z$

(10) For 400 RPM for 6000T coil with 28 gauge wire and 0.5" core:

- (a) CM: $0.49\text{v} / 2 \text{ mA} = 245 \text{ ohms} = Z$
- (b) SI: $5.48\text{v} / 0.13 \text{ mA} = 421.538 \text{ ohms} = Z$

(11) For 1200 RPM for 6000T coil with 28 gauge wire and 0.5" core:

- (a) CM: $1.25\text{v} / 1.5 \text{ mA} = 833.333 \text{ ohms} = Z$
- (b) SI: $15.04\text{v} / 4.1 \text{ mA} = 3668.293 \text{ ohms} = Z$

(12) For 1400 RPM for 6000T coil with 28 gauge wire and 0.5" core:

- (a) CM: $2.08\text{v} / 1.1 \text{ mA} = 1890.909 \text{ ohms} = Z$
- (b) SI: $18.76\text{v} / 2.5 \text{ mA} = 7504 \text{ ohms} = Z$

(13) For 400 RPM for 6000T coil with 28 gauge wire and 0.75" core:

- (a) CM: $0.64\text{v} / 1.7 \text{ mA} = 376.471 \text{ ohms} = Z$
- (b) SI: $7.97\text{v} / 7.4 \text{ mA} = 1077.027 \text{ ohms} = Z$

(14) For 1200 RPM for 6000T coil with 28 gauge wire and 0.75" core:

- (a) CM: $2.08\text{v} / 1.3 \text{ mA} = 1600 \text{ ohms} = Z$
- (b) SI: $20.4\text{v} / 5.6 \text{ mA} = 3642.857 \text{ ohms} = Z$

(15) For 1400 RPM for 6000T coil with 28 gauge wire and 0.75" core:

- (a) CM: $2.28\text{v} / 1.2 \text{ mA} = 1900 \text{ ohms} = Z$
- (b) SI: $28.4\text{v} / 2.1 \text{ mA} = 13523.81 \text{ ohms} = Z$

It is noted that, based upon the variations of wire size, core size and number of turns, the following effects take place:

- (a) the smaller the wire size the higher the gains regardless of speed;
- (b) the greater the number of turns, generally the higher the gains; and
- (c) the smaller the core size the higher the gains.

However, when comparing coils with smaller cores but a higher number of turns, the effects stay about the same.

Finally, the magnets are placed in the rotor so that they are all north or south poles up or out. A pure half-wave generator is created without rectifying the AC signal, which otherwise must be accomplished in a normal AC generator with electronic components in an electronic circuit.

Experimental Values for Producing Power the Conventional Way and with the Subject Invention:

The results were achieved using a small 3" magnet with a diameter of ± 2 " on a 1.25" high coil of 1" diameter and 3/8" centre/core of steel. (Unknown wire gauge size.)

(a) Conventional method of generating electricity:

1. 0.324 volts
2. 2.782 mA (milli-amps)
3. 0.9014 mW (milli-watts)

(b) Subject invention method of generating electricity:

1. 7.12 volts
2. 17.35 mA
3. 100.87 mW

(c) Associated gains of Volts, Current and Watts:

1. 2,198% over conventional voltage output.
2. 624% over conventional current output.
3. 13,713% over conventional power output.

The following results show the voltage, current and power outputs for an 1100, 2200 and 5500 turn coil of 20 gauge copper wire, 6" in length, 3" in diameter with a 0.75" core of steel. The results are those taken at 350 rpm, 1200 rpm and 1300 rpm.

(A) 350 RPM for an 1100 turn coil

	Volts	mA	mW
(a) Conventional method:	0.57	56.6	32.3
(b) Subject invention method:	1.14	106.6	121.5
(c) Associated gains	200%	188.3%	376.6%

(B) 350 RPM for a 2200 turn coil

	Volts	mA	mW
(a) Conventional method:	0.93	32.4	30.1
(b) Subject invention method:	2.94	70.1	206.1
(c) Associated gains	316.1%	216.4%	684%

(C) 350 RPM for a 5500 turn coil

	Volts	mA	mW
(a) Conventional method:	2.09	17.3	36.2
(b) Subject invention method:	6.11	37.9	231.6
(c) Associated gains	292.3%	219.1%	640%

(D) 1200 RPM for an 1100 turn coil

	Volts	mA	mW
(a) Conventional method:	1.45	60.2	87.3
(b) Subject invention method:	2.95	141	416
(c) Associated gains	203.4%	234.2%	476%

(E) 1200 RPM for a 2200 turn coil

	Volts	mA	mW
(a) Conventional method:	3.225	36.2	116.75
(b) Subject invention method:	7.53	73.5	553.5
(c) Associated gains	233.5%	203%	474%

(F) 1200 RPM on a 5500 turn coil

	Volts	mA	mW
(a) Conventional method:	4.81	17	81.77
(b) Subject invention method:	11.23	31.4	352.6
(c) Associated gains	235.5%	184.7%	431.3%

(G) 1300 RPM on an 1100 turn coil

	Volts	mA	mW
(a) Conventional method:	1.6	83	132.8
(b) Subject invention method:	4.59	157	704.9
(c) Associated gains	280.6%	189.2%	530.8%

(H) 1300 RPM on a 2200 turn coil

	Volts	mA	mW
(a) Conventional method:	2.75	50.5	138.9
(b) Subject invention method:	7.74	88.5	685
(c) Associated gains	281.5%	175.2%	493.3%

(I) 1300 RPM on a 5500 turn coil

	Volts	mA	mW
(a) Conventional method:	5.061	17.3	87.56
(b) Subject invention method:	12.76	36.4	464.5
(c) Associated gains	252%	210%	530%

The following readings are taken from a coil with 24 gauge wire, 0.5" centre/core of steel and 2300T.

(A) 400 rpm

	Volts	mA	mW
(a) Conventional method:	0.15	3.7	0.56
(b) Subject invention method:	2.45	26.2	64.2
(c) Associated gains	1,633%	708%	11,563%

(B) 1200 rpm

	Volts	mA	mW
(a) Conventional method:	0.37	2.7	1
(b) Subject invention method:	4.1	10.3	42.2
(c) Associated gains	1,108%	381%	4,227%

(C) 1400 rpm

	Volts	mA	mW
(a) Conventional method:	0.58	2.4	1.39
(b) Subject invention method:	8.31	7.8	64.82
(c) Associated gains	1,433%	325%	4,657%

The following readings are taken from a coil made with 24 gauge wire, 0.75" centre/core of copper, 2300T.

(A) 400 rpm

	Volts	mA	mW
(a) Conventional method:	0.23	4.2	0.97
(b) Subject invention method:	0.37	7.2	2.66
(c) Associated gains	137%	171%	235%

(B) 1200 rpm

	Volts	mA	mW
(a) Conventional method:	0.79	3.4	2.69
(b) Subject invention method:	1.43	6.9	9.87
(c) Associated gains	181%	203%	367%

(C) 1400 rpm

	Volts	mA	mW
(a) Conventional method:	0.79	3.2	2.53
(b) Subject invention method:	2.1	2.7	5.67
(c) Associated gains	266%	84%	224%

The following readings were taken from a coil made of 28 gauge wire, 0.5" centre/core of steel and 6000T.

(A) 400 rpm

	Volts	mA	mW
(a) Conventional method:	0.49	2	0.98
(b) Subject invention method:	5.48	13	71.24
(c) Associated gains	1,118%	65%	7,269%

(B) 1200 rpm

	Volts	mA	mW
(a) Conventional method:	1.25	1.5	1.88
(b) Subject invention method:	15.04	4.1	61.66
(c) Associated gains	1,203%	273%	3,289%

(C) 1400 rpm

	Volts	mA	mW
(a) Conventional method:	2.08	1.1	2.29
(b) Subject invention method:	18.76	2.5	46.9
(c) Associated gains	902%	227%	2,050%

The following readings were taken from a coil made of 28 gauge wire, 0.75" steel centre/core and 6000T.

(A) 400 rpm

	Volts	mA	mW
(a) Conventional method:	0.64	1.7	1.09
(b) Subject invention method:	7.97	7.4	58.98
(c) Associated gains	1,245%	435%	5,421%

(B) 1200 rpm

	Volts	mA	mW
(a) Conventional method:	2.08	1.3	2.7
(b) Subject invention method:	20.4	5.6	114.24
(c) Associated gains	981%	431%	4,225%

(C) 1400 rpm

	Volts	mA	mW
(a) Conventional method:	2.28	1.2	2.74
(b) Subject invention method:	28.4	2.1	88.04
(c) Associated gains	1,246%	175%	2,180%

The extrapolated voltages for the items immediately above at the 1800 RPM speed for the method of the subject invention are as follows:

(A) 400-1400 RPM, 0.5" core, 2300T:

- (1) 11.025v
- (2) 6.15v
- (3) 10.68v

(B) 400-1400 RPM, 0.75" core, 2300T:

- (1) 1.665v
- (2) 2.145v
- (3) 2.7v

(C) 400-1400 RPM, 0.5" core, 6000T:

- (1) 24.66v
- (2) 22.56v
- (3) 24.12

(D) 400-1400 RPM, 0.75" core, 6000T:

- (1) 10.25v
- (2) 30.6v
- (3) 36.51v

Some of the readings above do not seem consistent with others. This is attributed to the possibility that the wire connections may have been faulty or the proximity of the magnet relative to the core or coil may not have been the same. This was not taken into account at the time the tests were done.

The following figures are derived based on the premise that the subject invention has characteristics of a transformer when the number of turns on the coils change. In nearly all these situations, the subject invention acts exactly like a transformer, while the conventional way of producing electricity does not.

CM = conventional method;
 SI = subject invention;

350 RPM		1100 to 2200 Turns	1100 to 5500 Turns	2200 to 5500 Turns
CM:	expected voltage:	1.14 volts	2.85 volts	2.325 volts
	actual voltage:	0.93 volts	2.09 volts	2.09 volts
	expected current:	28.3 mA	11.32 mA	12.96 mA
	actual current:	32.4 mA	17.3 mA	17.3 mA
	expected power:	32.3 mW	32.3 mW	30.1 mW
	actual power:	30.1 mW	36.2 mW	36.2 mW
	expected voltage gain:	2	5	2.5
	actual voltage gain:	1.636	3.667	2.247
	expected current gain:	0.5	0.2	0.4
	actual current gain:	0.572	0.306	0.534
SI:	expected voltage:	2.28 volts	5.70 volts	7.35 volts
	actual voltage:	2.94 volts	6.11 volts	6.11 volts
	expected current:	53.30 mA	42.64 mA	28.04 mA
	actual current:	70.10 mA	37.90 mA	37.90 mA
	expected power:	121.74 mW	243.05 mW	206.09 mW
	actual power:	206.10 mW	231.60 mW	231.60 mW
	expected voltage gain:	2	5	2.5
	actual voltage gain:	2.579	5.36	2.078
	expected current gain:	0.5	0.2	0.4
	actual current gain:	0.658	0.356	0.5407
SI:	expected power gain:	1	1	1
	actual power gain:	0.932	1.12	1.203
	expected voltage:	2.28 volts	5.70 volts	7.35 volts
	actual voltage:	2.94 volts	6.11 volts	6.11 volts
	expected current:	53.30 mA	42.64 mA	28.04 mA
	actual current:	70.10 mA	37.90 mA	37.90 mA
	expected power:	121.74 mW	243.05 mW	206.09 mW
	actual power:	206.10 mW	231.60 mW	231.60 mW
	expected voltage gain:	2	5	2.5
	actual voltage gain:	2.579	5.36	2.078
expected current gain:	0.5	0.2	0.4	
actual current gain:	0.658	0.356	0.5407	
expected power gain:	1	1	1	
actual power gain:	1.696	1.906	1.124	

1200 RPM		1100 to 2200 Turns	1100 to 5500 Turns	2200 to 5500 Turns
CM:	expected voltage:	2.90 volts	7.25 volts	8.06 volts
	actual voltage:	3.225 volts	4.81 volts	4.81 volts
	expected current:	30.10 mA	12.04 mA	14.48 mA
	actual current:	36.2 mA	17.0 mA	17.0 mA
	expected power:	87.29 mW	87.29 mW	116.71 mW
	actual power:	87.29 mW	87.29 mW	116.71 mW
	expected voltage gain:	2	5	2.5
	actual voltage gain:	2.22	3.32	1.49
	expected current gain:	0.5	0.2	0.4
	actual current gain:	0.6	0.28	0.47
SI:	expected power gain:	1	1	1
	actual power gain:	1.34	0.94	0.70
	expected voltage:	5.9 volts	14.75 volts	18.83 volts
	actual voltage:	7.53 volts	11.23 volts	11.23 volts
	expected current:	70.50 mA	28.20 mA	29.40 mA
	actual current:	73.50 mA	31.40 mA	31.40 mA
	expected power:	415.95 mW	415.95 mW	553.60 mW
	actual power:	553.50 mW	352.60 mW	352.60 mW
	expected voltage gain:	2	5	2.5
	actual voltage gain:	2.55	3.81	1.49
expected current gain:	0.5	0.2	0.4	
actual current gain:	0.52	0.22	0.43	
expected power gain:	1	1	1	
actual power gain:	1.33	0.85	0.64	

1300 RPM		1100 to 2200 Turns	1100 to 5500 Turns	2200 to 5500 Turns
CM:	expected voltage:	3.20 volts	8.00 volts	6.88 volts
	actual voltage:	2.75 volts	5.06 volts	5.06 volts
	expected current:	41.50 mA	16.60 mA	20.20 mA
	actual current:	50.50 mA	17.3 mA	17.3 mA
	expected power:	132.8 mW	132.8 mW	138.98 mW
	actual power:	138.9 mW	87.56 mW	87.56 mW
	expected voltage gain:	2	5	2.5
	actual voltage gain:	1.72	3.16	1.84
	expected current gain:	0.5	0.2	0.4
	actual current gain:	0.61	0.21	0.34
	expected power gain:	1	1	1
	actual power gain:	1.05	0.66	0.63
SI:	expected voltage:	9.18 volts	22.95 volts	19.35 volts
	actual voltage:	7.74 volts	12.76 volts	12.76 volts
	expected current:	78.50 mA	31.40 mA	35.40 mA
	actual current:	88.50 mA	36.40 mA	36.40 mA
	expected power:	720.63 mW	720.63 mW	685.0 mW
	actual power:	685.0 mW	464.50 mW	464.50 mW
	expected voltage gain:	2	5	2.5
	actual voltage gain:	1.69	2.78	1.65
	expected current gain:	0.5	0.2	0.4
	actual current gain:	0.56	0.23	0.41
	expected power gain:	1	1	1
	actual power gain:	0.95	0.64	0.68

The following data represents the expected and actual voltage readings for the conventional method of producing voltage and the method of the subject invention. In virtually all circumstances, the herein invention produced more voltage than the conventional method and has gains that are higher than anticipated.

1100 Turns		350 to 1200 RPM	350 to 1300 RPM	1200 to 1399 RPM
CM:	expected voltage:	1.954 volts	2.117 volts	1.571 volts
	actual voltage:	1.45 volts	1.60 volts	1.60 volts
	expected voltage gain:	3.429	3.714	1.083
	actual voltage gain:	2.544	2.807	1.103
SI:	expected voltage:	3.909 volts	4.234 volts	3.196 volts
	actual voltage:	2.95 volts	4.59 volts	4.59 volts
	expected voltage gain:	3.429	3.714	1.083
	actual voltage gain:	2.579	4.026	1.556

2200 Turns		350 to 1200 RPM	350 to 1300 RPM	1200 to 1399 RPM
CM:	expected voltage:	3.189 volts	3.454 volts	3.494 volts
	actual voltage:	3.225 volts	5.061 volts	5.061 volts
	expected voltage gain:	3.429	3.714	1.083
	actual voltage gain:	3.468	2.957	0.853
SI:	expected voltage:	10.081 volts	10.919 volts	8.157 volts
	actual voltage:	7.53 volts	7.74 volts	7.74 volts
	expected voltage gain:	3.429	3.714	1.083
	actual voltage gain:	2.561	2.633	1.028

5500 Turns		350 to 1200 RPM	350 to 1300 RPM	1200 to 1399 RPM
CM:	expected voltage:	7.167 volts	7.62 volts	5.211 volts
	actual voltage:	4.81 volts	5.061 volts	5.061 volts
	expected voltage gain:	3.429	3.714	1.083
	actual voltage gain:	2.301	2.422	1.052
SI:	expected voltage:	20.951 volts	22.693 volts	12.166 volts
	actual voltage:	11.23 volts	12.76 volts	12.76 volts
	expected voltage gain:	3.429	3.714	1.083
	actual voltage gain:	1.838	2.088	1.049

2300 Turns	(0.5" core 24 gauge wire)	400 to 1200 RPM	400 to 1400 RPM	1200 to 1400 RPM
CM:	expected voltage:	0.45 volts	0.525 volts	0.432 volts
	actual voltage:	0.37 volts	0.58 volts	0.58 volts
	expected voltage gain:	3.00	3.50	1.167
	actual voltage gain:	2.467	3.867	1.568
SI:	expected voltage:	7.35 volts	8.57 volts	4.785 volts
	actual voltage:	4.10 volts	8.31 volts	8.31 volts
	expected voltage gain:	3.00	3.50	1.167
	actual voltage gain:	1.673	3.392	2.027

2300 Turns	(0.75" core 24 gauge wire)	400 to 1200 RPM	400 to 1400 RPM	1200 to 1400 RPM
CM:	expected voltage:	0.69 volts	0.805 volts	0.922 volts
	actual voltage:	0.79 volts	0.79 volts	0.79 volts
	expected voltage gain:	3.00	3.50	1.167
	actual voltage gain:	3.435	3.435	1.00
SI:	expected voltage:	1.11 volts	1.295 volts	1.688 volts
	actual voltage:	1.43 volts	2.10 volts	2.10 volts
	expected voltage gain:	3.00	3.50	1.167
	actual voltage gain:	3.865	5.676	1.469

6000 Turns	(0.5" core 28 gauge wire)	400 to 1200 RPM	400 to 1400 RPM	1200 to 1400 RPM
CM:	expected voltage:	1.47 volts	1.715 volts	1.459 volts
	actual voltage:	1.25 volts	2.08 volts	2.08 volts
	expected voltage gain:	3.00	3.50	1.167
	actual voltage gain:	2.551	4.245	1.664
SI:	expected voltage:	16.44 volts	19.18 volts	17.668 volts
	actual voltage:	15.04 volts	18.76 volts	18.76 volts
	expected voltage gain:	3.00	3.50	1.167
	actual voltage gain:	2,745	3.423	11.247

6000 Turns	(0.75" core 28 gauge wire)	400 to 1200 RPM	400 to 1400 RPM	1200 to 1400 RPM
CM:	expected voltage:	1.92 volts	2.24 volts	2.427 volts
	actual voltage:	2.08 volts	2.28 volts	2.28 volts
	expected voltage gain:	3.00	3.50	1.167
	actual voltage gain:	3.25	3.563	2.427
SI:	expected voltage:	23.91 volts	27.895 volts	23.80 volts
	actual voltage:	20.40 volts	28.40 volts	28.40 volts
	expected voltage gain:	3.00	3.50	1.167
	actual voltage gain:	2.56	3.563	1.392

CLAIMS

1. A generator for providing alternating electrical current comprising:
 - (a) an independently supported rotating drive shaft;
 - (b) a plurality of spaced apart magnets extending outwardly from the shaft, the magnets each creating magnetic flux and having a polar end with a particular north or south polarity, said magnets being circumferentially spaced and mounted around the shaft, such that the polar ends of the magnets extend away from and circumferentially around the shaft;
 - (c) a plurality of stationary coil elements, each said coil element comprising electrical windings wound about substantially the entire coil element, each of said coil elements further comprising a solid metal core with two ends extending substantially through the coil element at the centre of the coil element, each element being positioned such that one end of each of the cores is located in spaced, adjacent relation to the magnets, whereby rotation of the shaft causes rotation of the magnets around the shaft and in spaced, adjacent relation to the cores of the coil elements, the magnetic flux of the magnetics cutting the cores of the coil elements, creating alternating current in the coil elements; and
 - (d) a first housing in which some of the plurality of coil elements are mounted and a second housing in which the remainder of the plurality of coil elements are mounted.
2. The generator as in claim 1 wherein the magnets are spaced 90° apart around the shaft.
3. The generator as in claim 1 wherein magnets with north polar ends alternate with the magnets with south polar ends in spaced, circumferential relation around the shaft.
4. The generator as in claim 1 wherein all the plurality of magnets are magnets with the same polar ends.
5. The generator as in claim 1 wherein the magnets are equidistantly spaced around the shaft.
6. The generator as in claim 1 wherein the plurality of magnets is rotated by the drive shaft between and in spaced apart relation with the housings.
7. The generator as in claim 1 further comprising four magnets extending from the shaft, adjacent magnets being positioned perpendicular to each other, each magnet having either an outwardly extending north or south polar end, and said magnets being positioned such that a north polar end magnet follows a south polar end magnet, in spaced, circumferential relation around the shaft.
8. The generator as in claim 1 further comprising multiple north polar end magnets and multiple south polar end magnets extending from the shaft, said magnets being positioned in spaced, circumferentially relation around the shaft.
9. The generator as in claim 1 in which the shaft is positioned within a rotor and the magnets are circumferentially mounted on the rotor.
10. The generator as in claim 1 in which the shaft is connected to power means for rotating the shaft, whereby upon rotation of the shaft, the magnets are rotated around the shaft in spaced relation to the cores of the coil elements, thereby inducing an alternating electrical field along the length of each of the cores, thereby producing an alternating electric current in the windings of the coil elements.
11. The generator as in claim 10 further comprising means to transmit the alternating electrical current for electrical power usage.

GEOFFREY SPENCE

US Patent 4,772,816

20th September 1988

Inventor: Geoffrey M. Spence

ENERGY CONVERSION SYSTEM

This is a slightly reworded excerpt from this patent which has a substantial electrical output capable of providing it's own electrical input to be self-powering as well as generating kilowatts of excess power. The highly-respected Dr. Harold Aspden comments:

"In my Energy Science Report No. 8I, I also mentioned the apparatus designed by Geoffrey Spence, an inventor based in U.K. This is the subject of his U.S. Patent No. 4,772,816. Electrons injected into a chamber formed between two concentric electrodes are deflected into the inner electrode by a pair of magnets that provide a magnetic field along the central axis of the concentric electrodes. Of itself, this should add no excess energy, because the energy fed into accelerating the electrons is merely absorbed by electrostatic repulsion in charging the central electrode and so the capacitor. However, if that electron flow pulsates and there are connections to draw electron current from that central electrode then the pulsation implies a recurring sequence of charge and discharge. That 'magic capacitor' function is then harnessed.

The questions then are whether the Spence invention really works and whether it is commercially viable? Well, I wrote that Energy Science Report back in 1996, six years ago, and it is only a few months ago that I heard any more of that project. Geoffrey Spence has developed the prototype product to the stage where he has closed the loop in the sense that a portion of the output power was fed back to impart the energy needed to sustain the electron beams. He has a self-sustaining unit that can deliver kilowatts of useful electrical power with no visible energy input."

ABSTRACT

The apparatus uses a magnetic field (**80**) to accelerate a charged particle radially towards a target electrode (**10**). The increased kinetic energy of the particles enables the particle to give up more electrical energy to the target electrode (**10**) than was initially given to it. This charges the target electrode (**10**), and the increased energy is extracted from the apparatus by connecting an electrical load between the target electrode and a point of lower or higher potential.

US Patent References:

1717413	Jun, 1929	Rudenberg	310/306.
3202844	Aug, 1965	Hatch	310/306.
3234411	Feb, 1966	Klein	310/306.
3312840	Apr, 1967	Gabor	310/306.
3393330	Jul, 1968	Vary	310/306.
3899696	Aug, 1975	Shimadu	310/306.

DESCRIPTION

This invention relates to a process and apparatus for generating a potential difference between two or more electrodes and using charged particles as energy carriers.

Electrical power is usually generated by burning a fossil fuel and converting the energy released into rotary motion which drives electrical generators. This is cost-effective only if carried out on a large scale, the conversion process being inefficient; utilising natural resources, and producing waste products which can cause serious environmental pollution. An additional disadvantage is that the electrical power cannot be supplied directly to road vehicles or ships.

The energy-conversion process of this invention involves no health or pollution hazard and generates electrical power directly by a single-stage process without waste products. The overall energy-conversion factor and power-to-weight ratio are both high, making the apparatus suitable for most fixed and mobile applications.

One known apparatus for doing useful work by operating on electrons with a magnetic field is called the "betatron". This includes a doughnut-shaped vacuum chamber between the poles of a specially-shaped electromagnet. Thermionically-produced electrons are injected into the chamber with an initial electrostatic energy of about 50 keV. As the magnetic field builds up during its positive-going half-cycle, it induces an electromotive force within the doughnut, which force accelerates the electrons and forces them to move in an curved path, by

interaction with the magnetic field. An important distinction between the betatron and the energy converter of this invention is that in the former the magnetic field has got to be able to increase over a very short period, in order to accelerate the electrons sufficiently, whereas in the latter the magnetic field is virtually constant and the electrons fall inwardly to give up both their kinetic energy and electric charge to a central electrode.

The present invention aims at providing an energy converter which may be mobile and which has a permanent magnet or an energised source of magnetic radiation associated with it in order to amplify the electrical energy initially imparted to charge particles fed to, or produced in, a so-called "vacuum" chamber forming part of the generator, which increased energy is extracted from the target electrode on which the particles are incident.

Accordingly the present invention provides an energy converter as per the appended claims.

While the invention is not to be limited to any particular theory of operation, it is based on the fact that, when a charged particle is constrained to move through a radial distance d (irrespective of the path which it actually follows) through a magnetic field of intensity H , the work done on the particle is $H \times d$. For an electron carrying a charge e , and moving at a speed v over distance d , the total force on the electron is the centripetal force the sum of $H \times e \times v$, less the force exerted on the electron in the opposite direction by the centrifugal force, which is the sum of $(m \times v^2)/r$. By making the radius of the centre electrode appreciably greater than the orbit of equilibrium, the centrifugal force can be minimised, thus maximising the centripetal force, and hence the work done in bringing the charge to the electrode.

The process by which the converter of this invention works uses, as a source of charge, electrically-charged particles, for example electrons and/or ions. Two or more electrodes are housed in a low-pressure chamber. A magnetic field as specified below traverses the chamber: it emanates from a permanent magnet, electromagnet or a source of magnetic radiation. An external source of energy is used to give the charge particles initial kinetic energy, for example by heating, acceleration through an electric field, or from nuclear radiation. The energy-conversion process uses the magnetic field to transfer the charged particles along a desired orbit until they impinge on a central electrode (cathode). The work done on the particles (therefore the electrical potential attained by the cathode) is proportional to the resultant magnetic force times the distance over which the force acts. As the particles move within the chamber they cross the magnetic field. This produces a force acting on the particles, the force being proportional to the field strength, speed and electrical charge of the particles, and the sine of the angle of incidence between the path of the particle and the magnetic lines of force. This force has an angular component and a centripetal one, which forces the particles to travel along a spiral orbit.

An opposing centrifugal force also acts on the particles in opposition to the centripetal magnetic force. The electrode potential is proportional to the work required to be done on the charged particles to overcome both the centrifugal force and the electric field around the cathode as the charges accumulate and the potential difference between the electrodes increases. Maximum electrode potential is reached when the centrifugal and repulsive forces are equal to the centripetal force, after which no further charged particles reach the electrode. The radius of the electrode determines the minimal value voltage between the central and an outer electrode: as the central electrode radius is reduced (by sputtering or erosion) the centrifugal force increases, reducing the number of charged particles which can reach the central electrode and therefore the electrode potential, for a given field strength and particle speed. The difference in mass between ions and lighter charged particles, such as electrons, results in different centrifugal forces for given particle kinetic energies. The generator output and efficiency are optimised when the generator uses the maximum magnetic field to minimise the centrifugal force and to maximise the radial distance over which the force acts for a given field strength. Particles having the highest charge-to-mass ratio should be used.

Low pressure gases can be used as a charge source when ionised by particle collision and excitation within the chamber. Doped gases can minimise the energy level for ionising gas atoms/molecules thereby improving efficiency. However, the resultant magnetic force is lower for the heavier ions due to their lower velocity so that the electric field radiated by the high voltage electrode (cathode) can attract oppositely charged particles (+ ions) and subsequently discharge the electrode reducing the output voltage. Various methods can be used to overcome or reduce this effect. For example one method would be to separate the opposite charges and/or to use electrical biased grids to control the flow of opposite charges to the high voltage electrode.

Gaseous systems are generally more complex than single charge systems, providing higher currents at lower voltages, whereas single charge systems, for example electrons used in high vacuum chambers, can generate higher voltages.

The magnetic field can be from one or more permanent magnets and/or from one or more electromagnets; a static magnetic field produces a constant output voltage, while a varying field produces a varying voltage for particles with equal mass and velocity.

An external source is used to accelerate the charged particles to give them initial kinetic energy, which is released as heat when the particles collide with the electrode. When the energy represented by the increased voltage between the electrodes is greater than the energy required to provide the charged particles; and accelerate them, the conversion process is self-sustaining, the output energy being the difference between the sum of the kinetic energy lost and the energy generated. Charge flows from the central electrode via an external load to another electrode. The electrical energy (work) released is a function of the current (sum of charges that flow per second) times the potential difference. Electrical and thermal output can be controlled by varying: the field strength; the particle speed; the particle density (mean free path), and/or by incorporating a grid to control the rate at which particles reach the central electrode. The output is also proportional to the heat lost or gained, since the translational energy of the particle is proportional to its temperature. Heat liberated at the electrode can be returned to the particles to maintain their energy, or be utilised in a heat exchanger for external use. The generator normally uses non-reacting conductive material to prevent chemical reaction by gases, coolants etc. with the electrodes, container walls or other components. Various particle trajectories, directional movements and positioning of the orbiting particles can be used with appropriate magnetic fields. The low-pressure gas can be ionised by any suitable means: one method would be to use an electron/ion gun where the plane and direction of the injected particles is correct for the applied magnetic field. In gas apparatus, the electrons flowing through the external circuit, on reaching the anode, recombine with a gaseous ion to form a neutral gas atom/molecule. This atomic particle is duly re-ionised by collision and/or the electric fields, the energy being directly or indirectly derived from the work done by the resultant force acting on the charged particles.

In order that the invention may be better understood, it will now be described with reference to the accompanying schematic drawings, which are given by way of example, and in which:

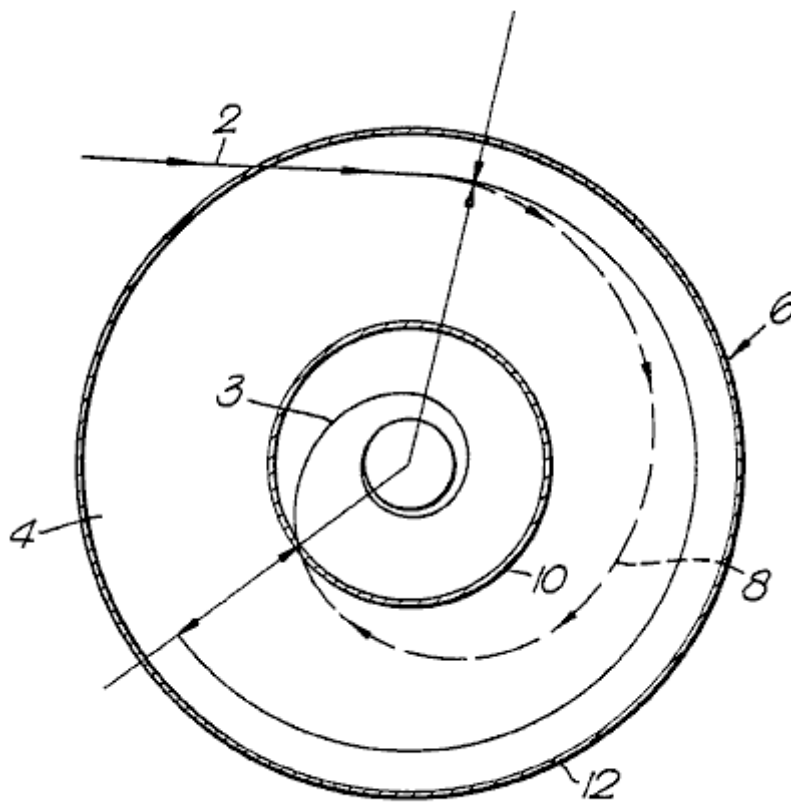

Fig. 1.

Fig.1 shows schematically a cross-section of the generator; and the path followed by a particle during the energy-conversion process;

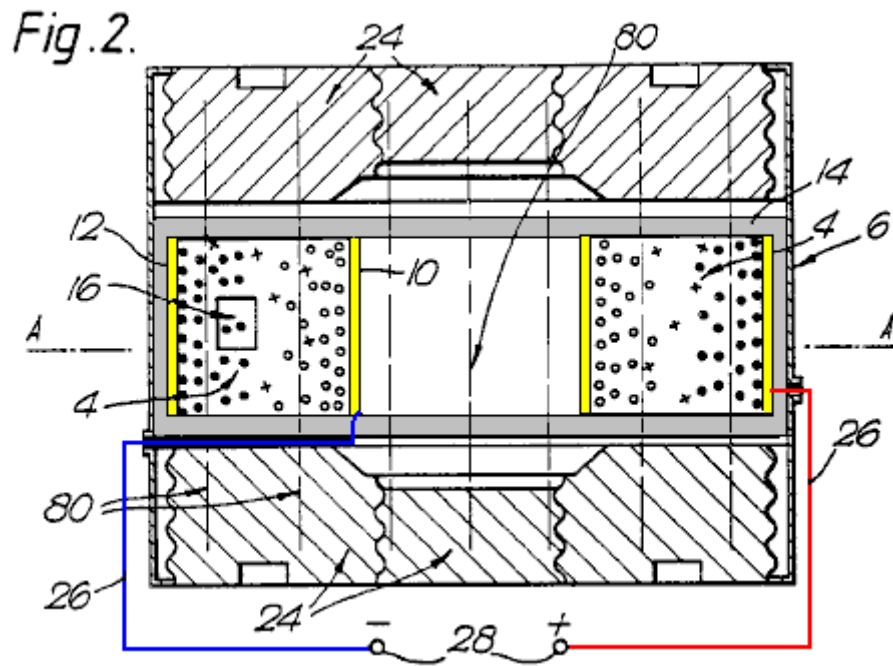

Fig.2 shows an axial cross-section of one type of apparatus for the invention, using permanent magnets; and a grid controlling ion migration to the cathode.

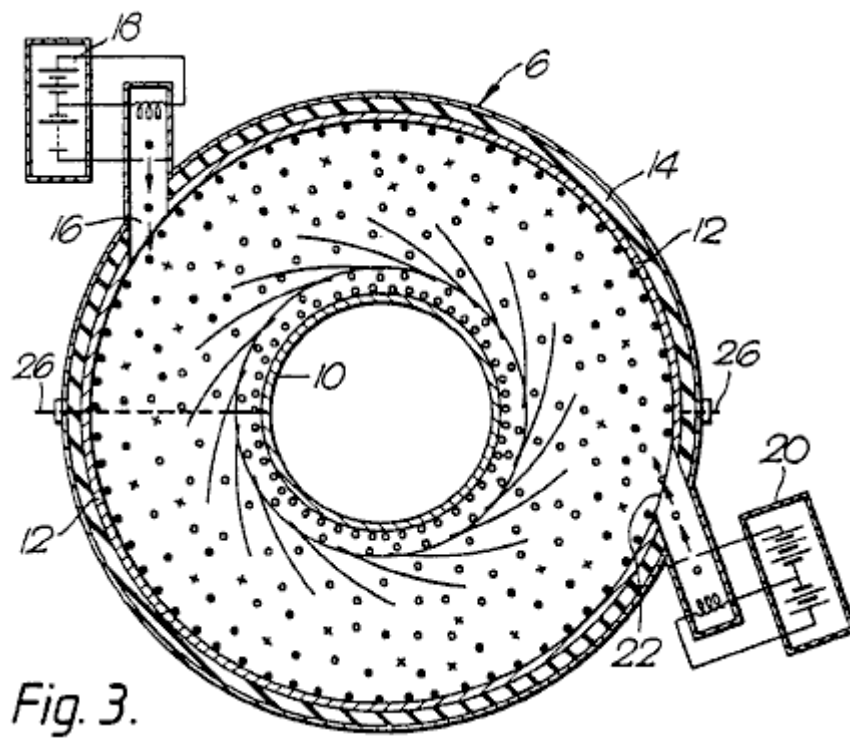

Fig.3 shows a cross-section of the apparatus of **Fig.2** along the line A--A;

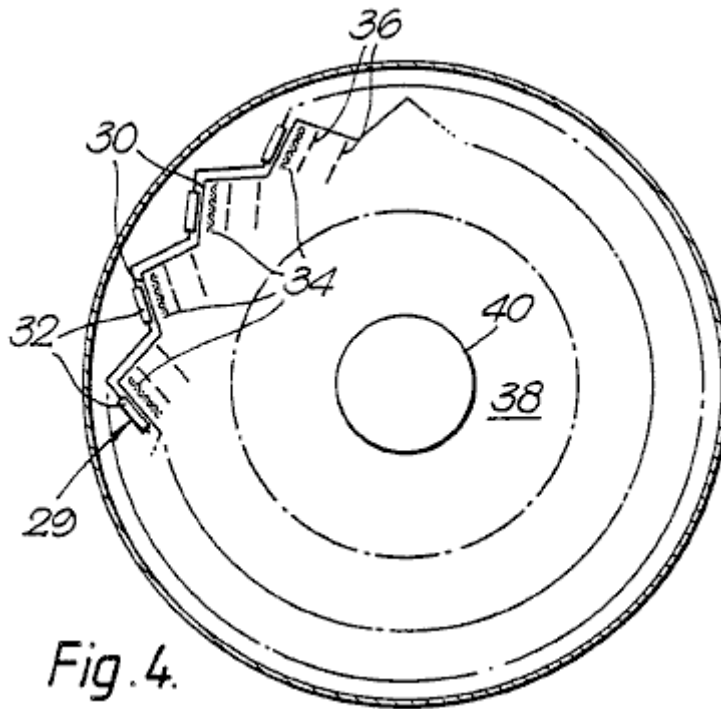

Fig. 4.

Fig. 4 is a diagrammatic section through one form of converter using electrons, showing a circular series of electron sources;

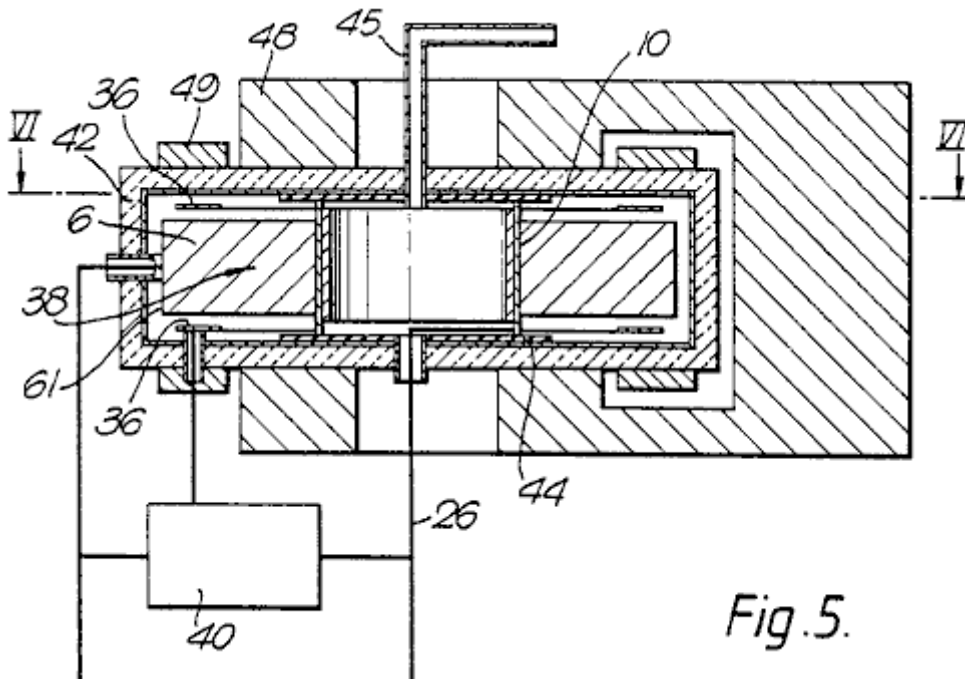

Fig. 5.

Fig. 5 is an axial cross-section through a more practical embodiment of the Fig. 4 converter;

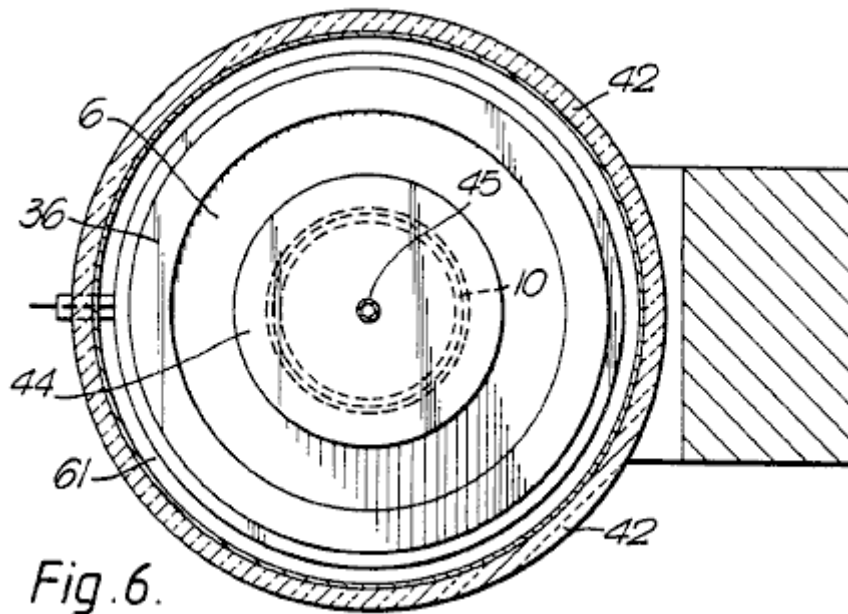

Fig. 6 is a section along the line VI--VI of Fig. 5;

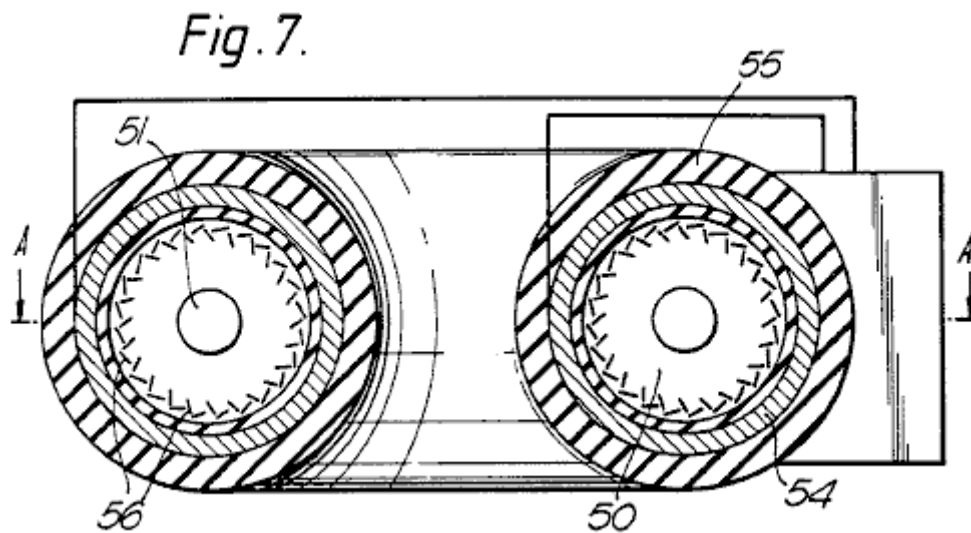

Fig. 7 is a cross-section along a diameter of a doughnut-shaped (toroidal) high-power converter;

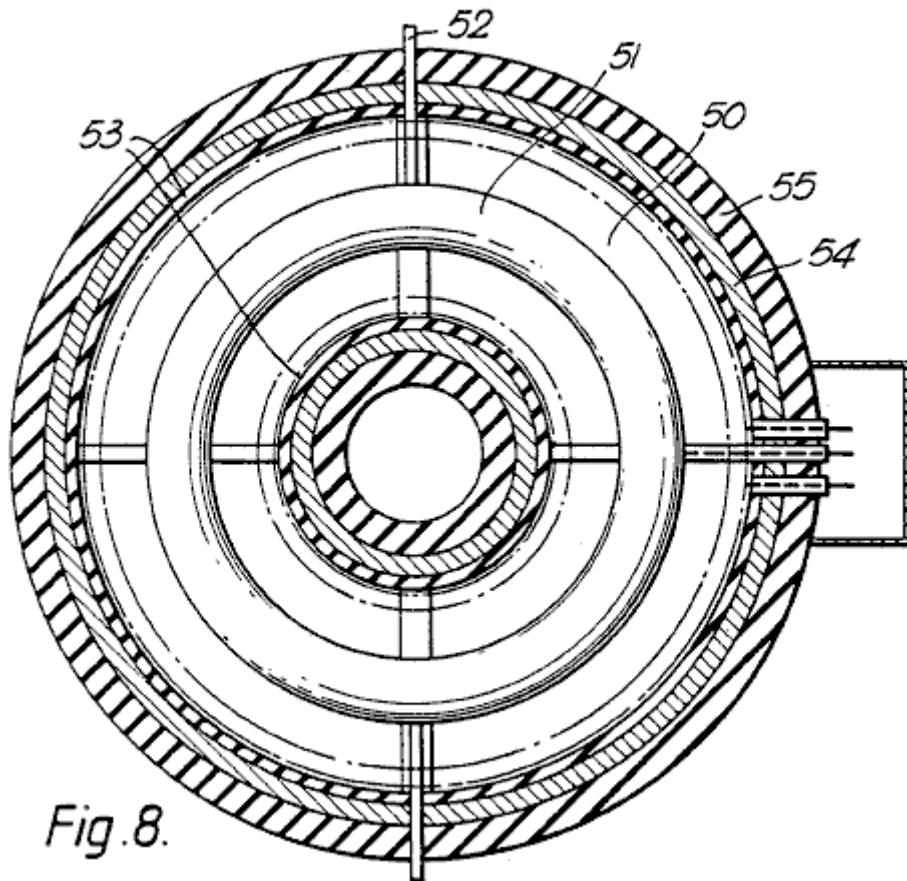

Fig. 8.

Fig. 8 is a section on line A-A of Fig. 7, and

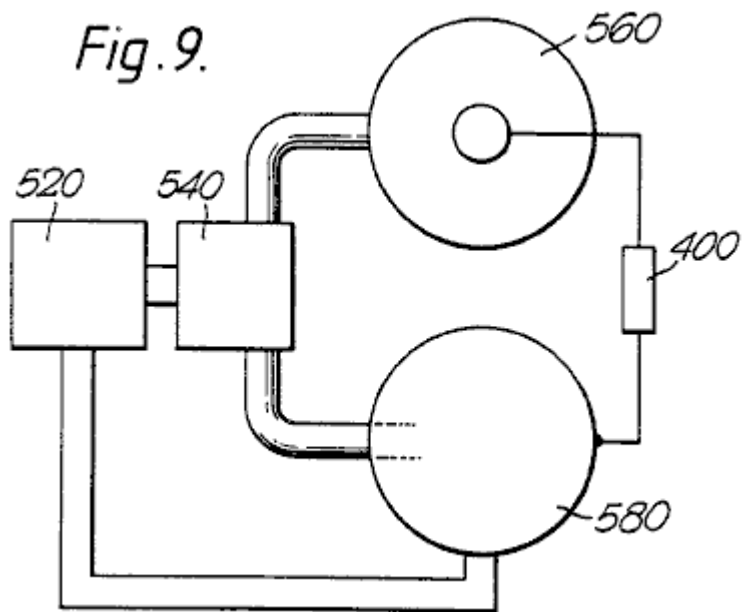

Fig. 9.

Fig. 9 is a scheme of a two-stage converter, using both forms of charged particles concurrently.

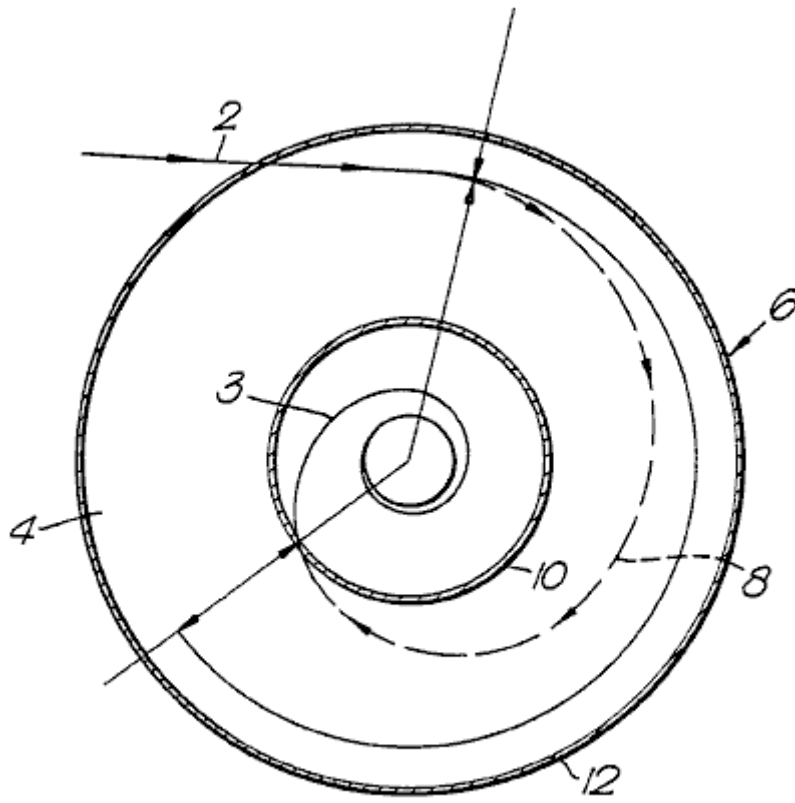
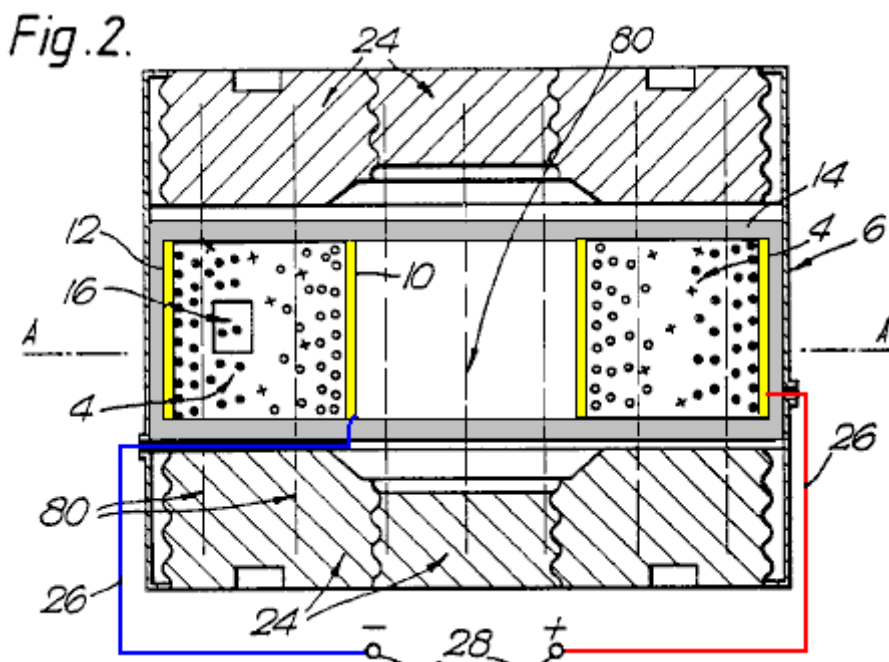

Fig. 1.

As shown in **Fig. 1**, a charged particle is injected along a trajectory **2** into a magnetic field extending normal to the plane of the drawing. The field permeates the space **4** of the annular cross-section within a cylindrical chamber **6**. The magnetic field produces a force on the particle, extending at right angles to both its direction of motion and the magnetic field. The resultant centripetal force causes the particle to follow a spiral path **8** ending on the central electrode **10** spaced radially inwards from the outer cylindrical electrode **12**. The extra energy acquired by the particle is a function of the radial distance travelled and the strength of the magnetic field between the electrodes. This energy is given up on impact with the central electrode, in the form of heat and/or work done in bringing the charge against the opposing electric field to the electrode. In the absence of the central electrode **10**, the electrons would follow the orbit of equilibrium **3**, this being the orbit followed by a particle when the centrifugal and centripetal forces balance, resulting in no work being done on the particle.



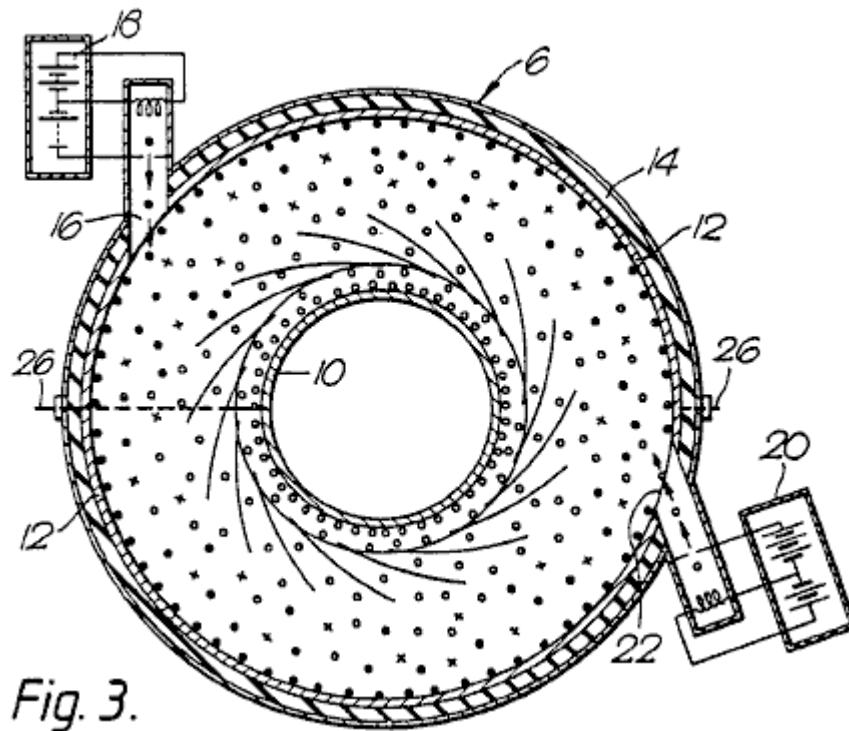

Fig. 3.

As shown more particularly in **Fig.2** and **Fig.3**, the energy converter **1** consists basically of a annular chamber **6** having an outer cylindrical electrode **12**; an inner cylindrical electrode **10**, and two gas-tight walls **14** of electrical insulation material. In the electrode **12** is a port **22** through which an electron gun **20** can inject electrons into space **4**. Additionally or alternatively, an ion gun **18** can inject positively-charged particles through port **16**.

Seated on the major flat surfaces of chamber **6** are magnetic pole-pieces **24** giving rise to a uniform magnetic field **80** which traverses the space **4** parallel with the axis of chamber **6**. The magnets may be ceramic permanent magnets, or they may be electromagnets. In either case, means (not shown) may be provided for adjusting the magnetic field strength.

Heavy conductors **26** connect the two electrodes to terminals **28** across which a resistive load can be placed to dissipate the generator output.

A vacuum pump (not shown) has its inlet in communication with the interior of chamber **6** so that the gas pressure in the generator can be reduced to, and kept at, a desired sub-atmospheric value. Associated with the pump, or separate from it, may be means for ensuring that the gas in the generator is of a desired composition, for instance, one which enhances the possibility of ionising collisions between the charged particles and gas atoms or molecules. One such suitable gas would be neon containing 0.1% argon by volume.

In order to cause the generator to start working, it is necessary to start the vacuum pump and to energise the electron gun or each particle source. The latter involves heating a filament from an external source of power until the required internal energy level (temperature) is reached which in turn causes a piece of thermo-emissive material to emit electrons. If the electrons are to be the charge carriers, they are accelerated by a suitable electric field and projected into the space **4**. Here they are further accelerated by the radial electric field between the electrodes, and at the same time have a deflecting force applied to them by the axial magnetic field through which they pass.

For an ion source, the electrons are accelerated until they impact some atoms or molecules, to produce a stream of ions which likewise pass into the space **4**. With the polarities shown, the electrons are attracted to the central electrode, while the ions are pulled towards the outer electrode, which accounts for the different orientations of sources **18** and **20**.

Any gas molecules which pass close to, or between, the electrodes are ionised by collision and/or the electrostatic field. Output current can then be taken through a load impedance connected across terminals **28**. The impedance is matched to prevent the internal process energy dropping below a value which would prevent the re-ionisation of the gaseous atoms. As each ion is deionised at the anode, the gas atoms will tend to continue to circulate until re-ionised, the resultant force drawing both the ions (shown by solid circles) and electrons (shown by hollow circles) back into their respective orbits.

It is envisaged that, in the case of a converter using electrons, the chamber could be evacuated to a chosen sub-atmospheric pressure and sealed.

In that form of the invention shown in **Fig.4**, each electron source forming one of a circular series **29** of sources has a body **30** of electro-emissive material, such as molybdenum coated by caesium, heated by an electric filament **32** connected in series or parallel across a source of electric power (not shown). Immediately in front of each emitter **30** is a grid **34** of fine wires, all the grids being connected with a source of adjustable voltage so as to control the flow of electrons from the emitter. These electrons are projected through one or more acceleration electrodes **36** across which a potential difference is established along the electron path, so that each incremental electron source injects a stream of electrons having known kinetic energy into a space **38**, indicated by the circle shown in a broken line, traversed by the deflection magnetic field, within which is the central, target, electrode **40**. The stream of electrons injected into the magnetic field may be focused by electric and/or magnetic fields.

In the remaining Figs, those parts already referred to will retain the same references.

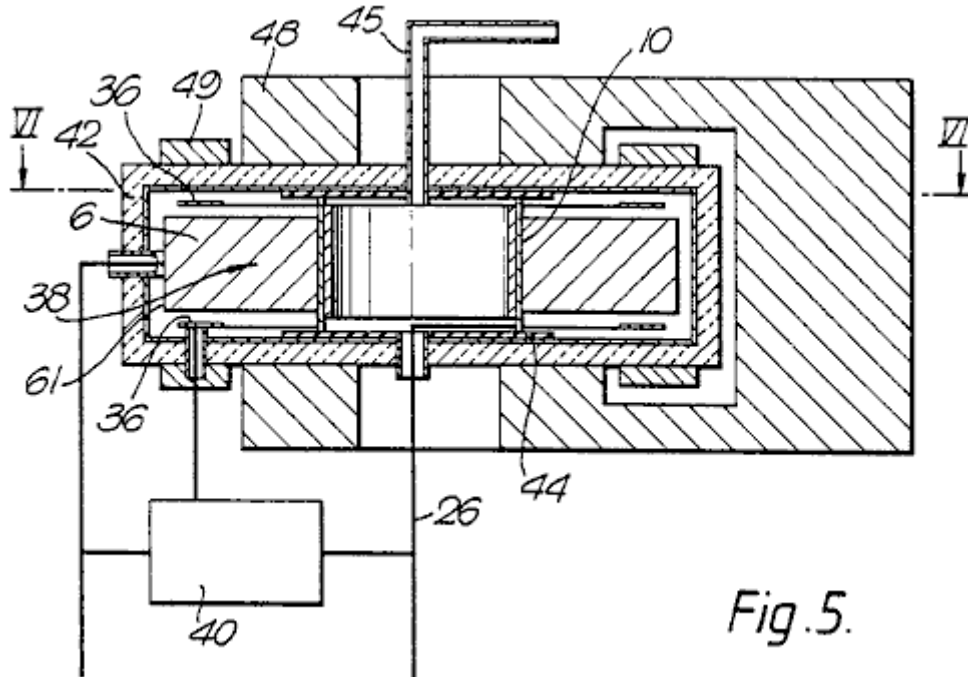

Fig.5.

In the "flat disc" configuration shown in **Fig.5**, the annular chamber **6** is enclosed in a body **42** of thermal insulation material. The central electrode **10** is seated on insulators **44** which are pierced by conduits **45** for the passage of a coolant fluid and by an output lead **26**, which may extend along the conduit so that it too is cooled.

Fig.5 shows how the deflection magnet is generally U-shaped, and has two annular pole-pieces **48**, so that the magnetic field is uniform between the surface of electrode **10** and the region **38** radially innermost of the circular electron source, the electric field between the electrode **36** and emission surface **61** providing the electrons initial accelerations (kinetic energy). **Fig.5** also shows how a voltage is tapped off the resistive load **40** (which thus functions as a potentiometer) and is fed through to the acceleration electrode **36**.

Chamber **6** is also provided with two annular magnets **49** (or a circular series of incremental magnets) designed to influence the direction along which the electrons pass into space **38**. The magnets provide local magnetic fields to ensure that the electrons meet the boundary of space **38** tangentially, i.e. with zero radial velocity.

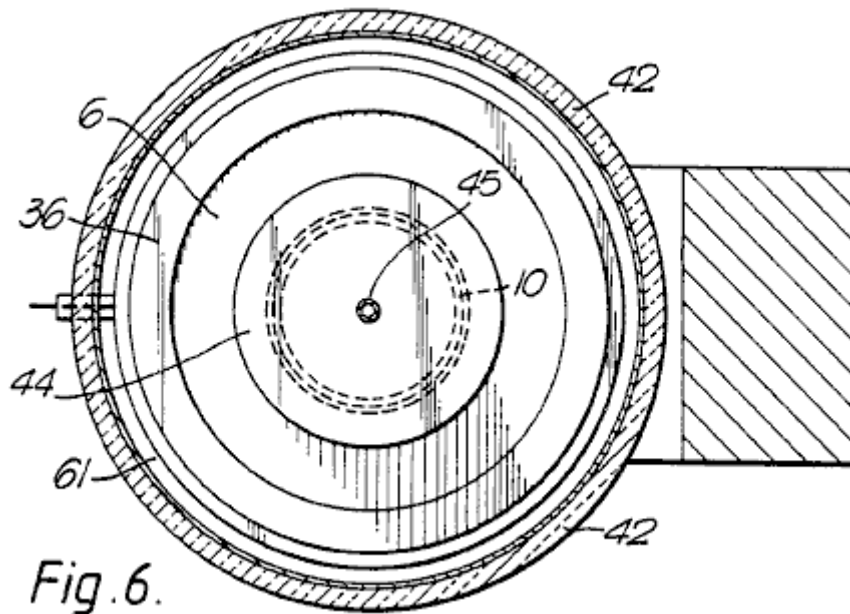
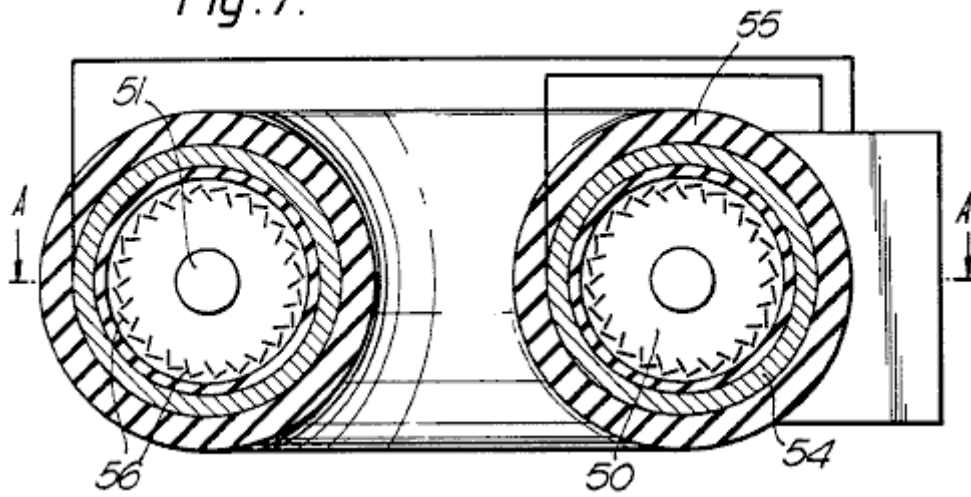

Fig. 6.

Fig. 7.



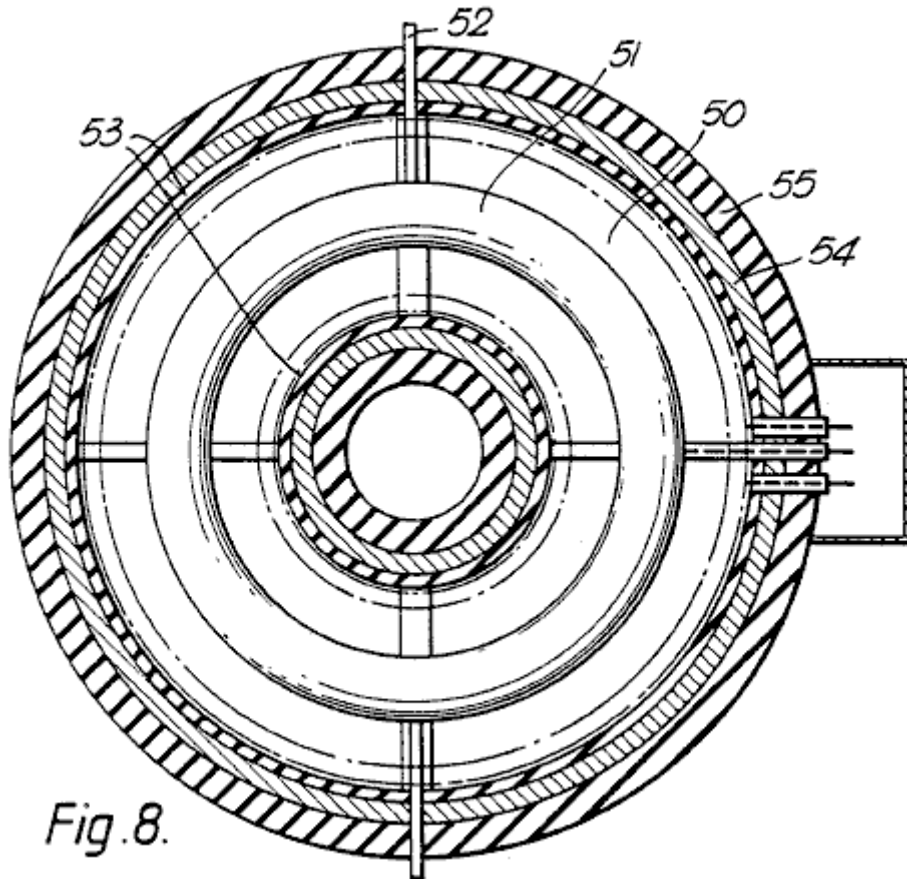
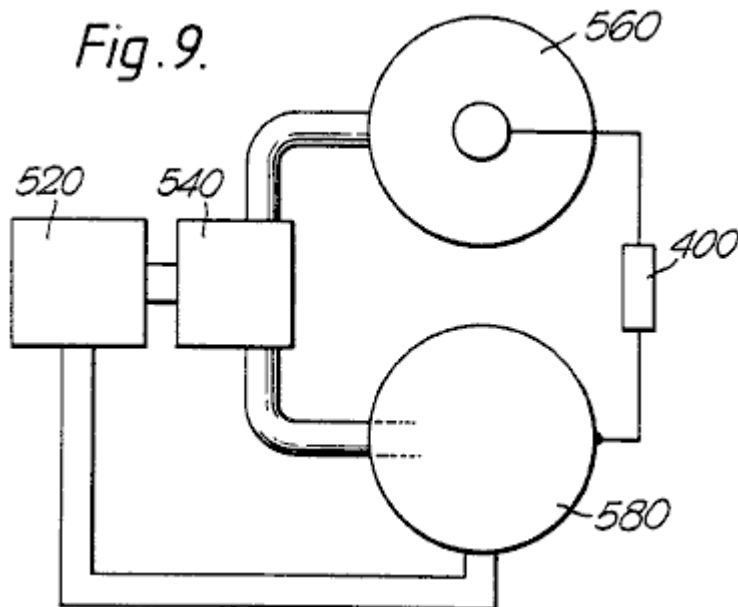

Fig. 8.

In that form of the invention shown in **Fig.7** and **Fig.8**, the individual "flat disc" converters of **Fig.5** and **Fig.6** are arranged in a type of "circular" construction, such that the magnetic fields extend along the axis of the resulting toroidal space **50** penetrated by a single toroidal target electrode **51** through which a coolant fluid may pass, along conduits **52**. The cross-section of **Fig.8** shows that the magnetic fields are supplemented by an electric field produced by windings **53** wound on a magnetic core **54** bounded by insulation **55**.

Apart from the fact that the electrodes are common to all converters, each functions individually as described above. Obviously the power source driving the heaters for the electron guns **56**; the electromagnets (if any); the acceleration electrodes and the control grids, have to be of sufficient capacity to supply the greater power needed to drive this "toroidal" configuration. Some changes would need to be made to the physical dimensioning and positioning of the relatively-complex construction, but as all these are readily understood by a competent engineer, they are not further described in this specification.

Fig. 9.



As already mentioned, the converters of this invention are of two types, i.e. electronic and ionic. **Fig.9** shows diagrammatically how they may be combined to take advantage of their differences. In the two-stage power generation apparatus shown in **Fig.9** the first stage consists of an ioniser **520** supplying a mixture of charged particles, i.e. ions and electrons, to a separator **540**, which supplies electrons to a second stage consisting of a sealed electronic converter **560** in parallel with a gaseous ionic converter **580**.

The separator **540** may use the different particle masses to separate them centrifugally using, for example, the energy conversion system of **Fig.1** (without the target electrode), or it may use electromagnetic deflection fields, or a physical diffusion process, either alone or in combination. As this is not part of the subject-matter of this invention, it will not be described herein in any further detail.

In the generators of **Fig.6** and **Fig.8**, the respective particles are deflected magnetically and accelerated radially, to function as already described above.

Because each generator is designed to operate most effectively with its particular form of charge carrier, it can be designed optimally, thus reducing the energy absorption caused by ions and electrons recombining before each has fallen on its respective target electrode. Because the electronic converter would finish up with a negatively-charged electrode, whereas the converse is true for the ionic converter, the load **400** extracting energy from the apparatus is connected across the two target electrodes. The other two electrodes of the converters may be held at the same potential, as by being connected together, or their potentials may float.

The generator can be designed to produce a wide range of output voltages and currents. The lower-energy generators are light enough to be mobile, so that they can power vehicles or act as stand-by generators. Various electrode and magnet configurations can be used, and the generators can be connected in series or parallel. Cooling jackets are fitted to prevent overheating in high-powered apparatus, and the generator is enclosed within a thermally-insulating jacket to reduce heat losses thereby increasing particle velocities. For high-energy generators, it may be necessary to provide for forced cooling of the inner electrode, as by fins projecting therefrom into a high-speed stream of suitable coolant.

Although the process according to this invention is particularly suited to using external electrical energy, it must be understood that other sources can be used to provide the initial energy input, e.g. solar and waste process heat are some of the varied energy sources which could be utilised. Control of the charge-generation process can be achieved by other means, including one or more electrically-biased grids, as used in thermionic valves.

CLAIMS

1. An energy conversion process for generating an electric potential, the process comprising; providing a source of electric charge carriers of predetermined polarity, accelerating the carriers away from the source, introducing the carriers into a magnetic field transverse to the path of the carriers in a process chamber, the field bounding an inner electrode within the chamber such that the carriers orbit the electrode while accelerating radially toward the electrode; and converting the resulting increased kinetic energy of the carriers

into an electric potential at the electrode before the carriers reach an orbit of equilibrium in which the centripetal force is balanced by the centrifugal force on the carriers.

2. A process according to claim 1 in which the electric potential is created between the inner electrode and an outer electrode radially spaced from the inner electrode.
3. A process according to claim 2 in which the outer electrode provides the said source of the charge carriers.
4. A process according to claim 1 or claim 2 in which the chamber is maintained at a sub-atmospheric pressure.
5. A process according to claim 1 in which the electric potential drives a load connected between the inner electrode and a point remote from the electrode.
6. A process according to claim 1 or claim 2 in which the electric charge carriers comprise electrons or ions.
7. A process according to claim 1 in which further charge carriers of the opposite polarity traverse the magnetic field and accumulate at a second electrode to increase the potential difference between the two electrodes.
8. A process according to claim 1 in which electrically biased grids control the flow of the charge carriers from the source.
9. A process according to claim 1 in which the charge carriers are separated from charge carriers of the opposite polarity before being introduced into the magnetic field.
10. A process according to claim 9 in which the charge carriers of opposite polarity are introduced into a corresponding second magnetic field, whereby a potential difference is produced between respective electrodes in each field.
11. A process according to claim 1 in which the carriers are injected into the magnetic field.
12. A process according to claim 11 in which the injection energy is produced by accelerating the carriers through an electric field.
13. A process according to claim 11 in which the injection energy is produced by accelerating the carriers through a magnetic field.
14. A process according to claim 1 in which the injection energy of the carriers is produced by nuclear emission.
15. A process according to claim 1 in which the injection energy of the carriers is produced by heat.
16. A process according to claim 1 in which the generated electric potential is directly or indirectly used to maintain the generation of charge carriers or the internal temperature of the space traversed by the magnetic field, or the applied magnetic field.
17. A process according to claim 1 in which the generated electric potential is directly or indirectly used to maintain the generation of charge carriers and the internal temperature of the space traversed by the magnetic field and the applied magnetic field.
18. An energy converter including a source of electric charge carriers of a predetermined polarity, a process chamber having an inner electrode, means for accelerating the carriers away from the source and for introducing the carriers into the chamber, means for applying a magnetic field transverse to the path of the carriers and bounding the inner electrode of the chamber such that the carriers orbit the electrode while accelerating radially toward the electrode, the electrode being located at a radius which exceeds the equilibrium radius for the carrier mean velocity and applied field strength and intercepting the carriers such that the increased kinetic energy of the carriers due to centripetal acceleration is converted to an electric potential at the electrode.
19. An energy converter according to claim 18 in which the chamber includes an outer electrode spaced radially from the inner electrode, and means for injecting the charge carriers into the space between the electrodes.
20. An energy converter according to claim 19 in which the outer electrode provides the said source of charge carriers.
21. An energy converter according to claim 19 further comprising an insulating wall bounding the outer electrode.

22. A converter according to claim 18 further comprising means for maintaining the chamber at a predetermined sub-atmospheric pressure.
23. A converter according to claim 19 in which the outer electrode has at least one port through which the charge carriers can be injected into the chamber along a desired trajectory.
24. A converter according to claim 23 in which the outer electrode has plural ports and each port communicates with a thermionic source of the respective carriers.
25. A converter according to claim 18 in which the chamber is a vacuum chamber.
26. A converter according to claim 18 further comprising electrically biased grids for controlling the flow of charge carriers from the source.
27. A converter according to claim 22 or claim 25 in which the evacuated chamber comprises a sealed unit.
28. A converter according to claim 18 further comprising means for adjusting the strength of the applied magnetic field.
29. A converter according to claim 18 in which the chamber is filled with low pressure gas.

METHOD AND APPARATUS FOR INCREASING ELECTRICAL POWER

This patent shows a method of altering a standard electrical generator intended to be driven by a separate motor, so that it operates without the motor. In an example quoted, a DC input of 48 volts at 25 amps of current (1.2 kW) produces a 110 volt 60Hz AC output of 3.52 kW. That is a Coefficient Of Performance of 2.93 at an output level suited to Off-The-Grid operation of a house.

ABSTRACT

A form of rotating machine arranged in such a way as to convert a substantially constant input voltage into a substantially constant output voltage; involving generally, a rotor that revolves at a substantially constant speed within a stator, and which comprises a transformer core subjected to and having a primary motor-transformer winding and a secondary transformer-generator winding; whereby transformed and generated power are synchronously combined as increased output power.

BACKGROUND

Electrical power is frequently changed in voltage, phase, frequency, and the current is changed from alternating to direct or from direct to alternating. Voltage conversion in AC circuits is usually by means of transformers, and in DC circuits is usually by means of motor-generators. Phase conversion is also accomplished by either transformers or motor-generators, and frequency conversion is most simply done by motor-generators.

Motor-generators have various classifications of use, as follows:

- (1) DC to DC, used to charge batteries and to boost voltage.
- (2) AC to AC, used for frequency and phase conversion
- (3) AC to DC used for all types of service, such as battery charging, generator and motor field excitation, railways, electrolysis, and speed control etc. and
- (4) DC to AC used to limited extent for special applications.

To these ends combination motor-generators have been built, such as dynamotors stepping up DC voltage for radio equipment and amplidynes for reproducing a weak signal at a higher power level. When a particular variable frequency A.C. is required of a motor-generator set and the power supply is DC, the equipment will include a DC motor for variable speed and a separate alternator driven by it. Such equipment is special in nature and characterised by separation of the motor and generator and by polyphase (usually three-phase) generator windings and with auto transformers having suitable taps for obtaining the required voltages; and a DC speed controller for the motor. The phase output of such equipment is selective and its single phase capacity necessarily restricted (66%) as compared with its three-phase capacity, in which case transmission efficiency for single phase is poor.

When a higher level power output is desired, the amplidyne is employed with field windings and brushes equipped for the purpose, and in some instances to give a constant current output from a constant voltage input, for example, in inverted rotary converter provided to convert DC to A.C. However, the present invention is concerned with method and apparatus for increasing electrical power and provides a dynamo-electric converter that operates from an electrical energy supply to produce A.C. most efficiently for a useful load.

The method involves simultaneous motor-transformer-generator steps and the preferred embodiment of the apparatus involves a dynamo-electric converter (DEC) in the form of a rotary machine combined in a single rotor revolving within a stator, the rotor being comprised of a transformer core having both a primary motor-transformer winding and a secondary transformer-generator winding, and the stator being comprised of magnetic field poles.

Synchronous converters have been combined in single rotor machines to produce DC from A.C., but that effect is quite different from the effect of the present invention when A.C. is to be produced from DC in a single rotor having primary and secondary armature windings as distinguished from armature windings common to both A.C. and DC circuits. With the present invention, both a transforming and a generating effect are produced in the rotor, all of which is inherently synchronised and delivered through the A.C. outlet leads. A.C. motors and DC generators have been combined in one machine, that is in one rotor, and referred to as synchronous converters.

However, synchronous converters are lacking in their ability to change DC into A.C. when operating from the former as a prime mover to drive a generator simultaneously, and more specifically to drive an alternator synchronously.

SUMMARY OF INVENTION

This method involves the placement of a primary winding in a field to both motor the same and to have a transformer effect with respect to a secondary winding also in a field to have a generator effect. In its preferred embodiment, this dynamo-electric converter is comprised of primary and secondary windings combined in a rotor commutated to alternate a DC energy supply in and thereby motivate the rotor within a stator field. The primary winding is advantageously of fewer turns than the secondary and by means of electromotive force drives the secondary windings of more turns to cut the magnetic lines of force for the generation of electrical energy at a higher voltage level than the DC supply. This DC operated motor is shunt wound with the stator field poles fully energised by the DC energy supply, or is provided with permanent magnet field poles, to efficiently motivate the rotor and efficiently generate electrical energy in the secondary windings. The A.C. output of the secondary windings is inherently synchronised with the transformer function of the primary windings combined in the common slots of the single rotor; and by adding the transformer and generator voltages and amperages the wattage is correspondingly increased at the output.

DRAWINGS

The various objects and features of this invention will be fully understood from the following detailed description of the typical preferred form and application, which is made in the accompanying drawings, in which:

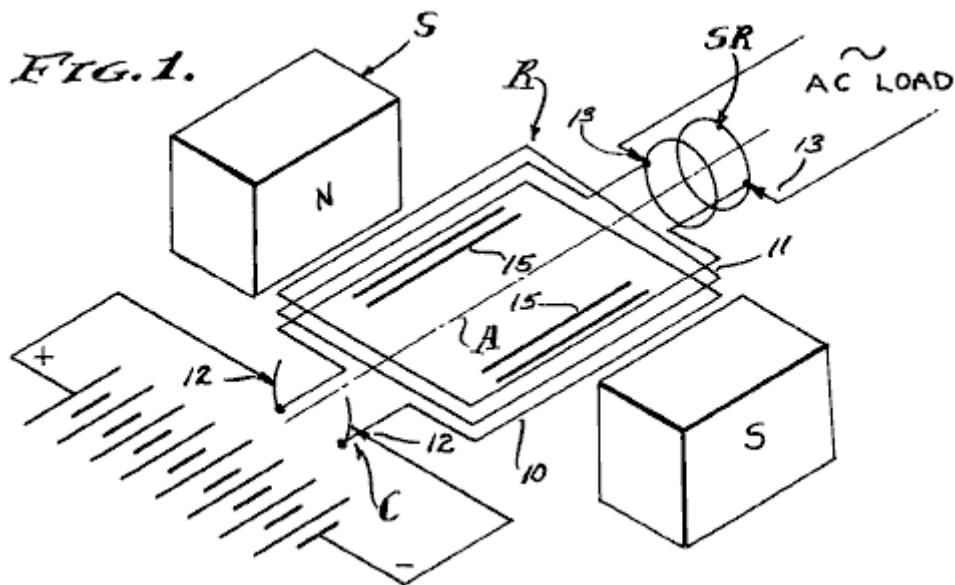

Fig.1 is a diagrammatic schematic view of the dynamo-electric converter components comprising the present invention.

FIG. 2.

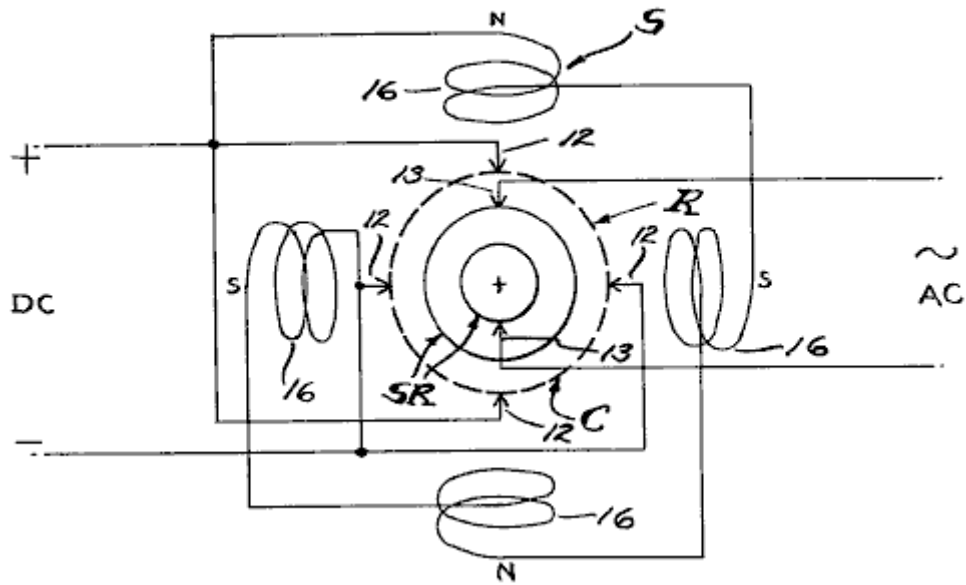

Fig.2 is a diagram of a typical commutator brush, slip ring brush and field pole arrangement which is utilised.

FIG. 3.

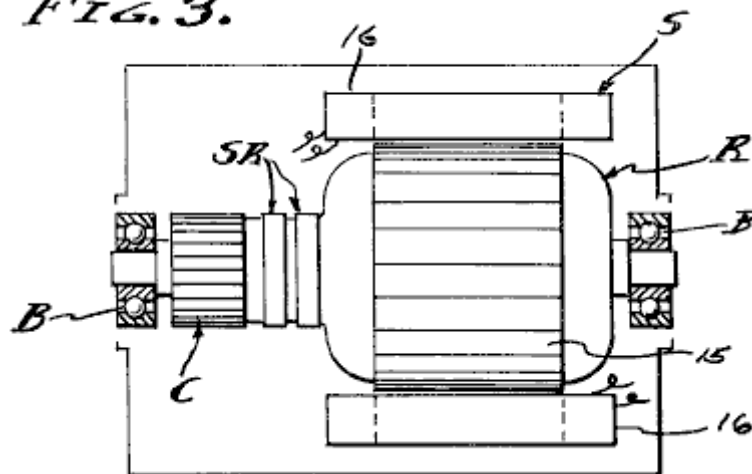

Fig.3 is a longitudinal section through a machine embodying the stator and rotor on bearings with the frame and brushes removed.

FIG. 1.

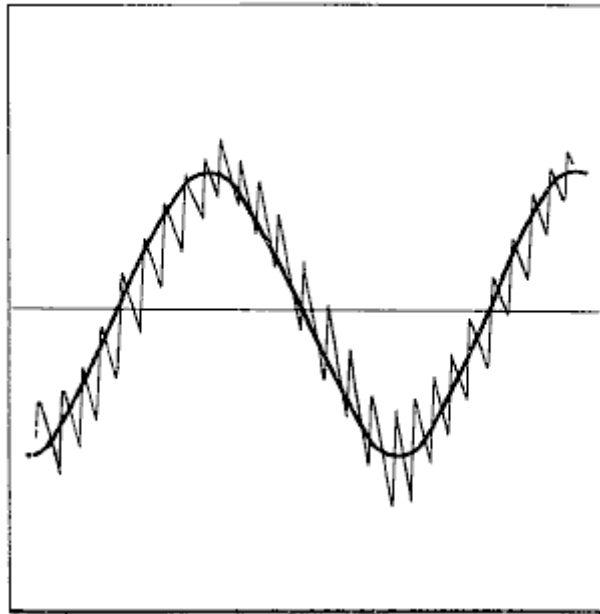
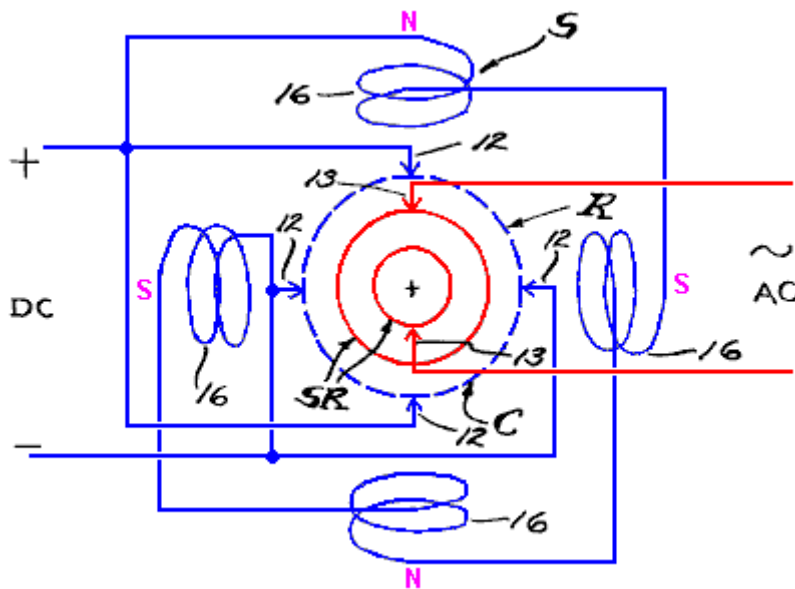

Fig.4 is a typical duplicate of an oscilloscope diagram showing the power output of the dynamo-electric converter.

PREFERRED EMBODIMENT



The dynamo-electric converter is illustrated diagrammatically in the drawings and involves, generally, a rotor **R** carried upon spaced bearings **B** so as to rotate on an axis **A** concentric within a stator **S**. The rotor **R** comprises the armature, while the stator **S** comprises the field, there being a commutator **C** associated with primary windings **10** on the rotor and slip rings **SR** associated with secondary windings **11** on the rotor. Brushes **12** and **13** are engaged slideably with the commutator and slip rings respectively, by conventional means, to conduct DC through the commutator **C** and to conduct AC through the slip rings **SR**. The brushes **12** and interconnected primary windings **10** comprise a motor while the brushes **13** and interconnected secondary windings **11** comprise a generator or alternator.

In practice, the field windings **16** can be separately energised or connected in parallel with the brushes **12** or shunted with respect to the primary motor winding **10**. Motorisation of the armature rotor **R**, or motoring thereof, causes continued polarity reversals on a cycle basis as determined by the speed of rotation, and this of course results in magnetic reversals in the rotor core **15** and a consequent induction in the secondary windings **11**. A feature of this invention is the combining and co-operative relationship of the primary and secondary windings which occupy common slots in and embrace a common portion of the core **15** of the rotor **R**, thereby to have a

transformer function as well as a generator function as the lines of magnetic force are cut by the secondary windings. The stator **S** has field poles of opposite magnetic polarity, excited independently from the armature, or as permanent magnets, and preferably shunted across the DC input. As shown, there are four equally spaced field poles in a circumferentially disposed series.

In practice, the primary DC motor windings are of fewer turns in the rotor slots than the secondary AC generator windings. For example, the primary motor windings **10** are flat wound between north to south poles of the field while the secondary generator windings are flat wound in the same or common slots of the rotor armature. In a typical unit having a four brush commutator with 20 bars and having a 20-slot armature, the primary windings **10** are comprised of a number of turns of conductor efficiently to draw 48 volts DC at 25 amperes or 1,200 watts to rotate at 1,750 rpm, while the secondary windings **11** are comprised of a number of turns of conductor efficiently to deliver 60 cycle (by transforming and generating) 110 volts AC at 32 amperes or 3,520 watts, the volt meter used to read these values upon an actual reduction to practice being calibrated to read the root-mean-square (RMS) value of the pure sine wave, which is 70.7% of the peak voltage.

The reduction to practice previously referred to as a "typical unit" was constructed of a machine originally designed as a self-exciting 60 cps 110 volt 2.5 kVA generator to be shaft driven by a separate prime mover. Firstly, the prime mover was eliminated. The exciter windings were intended to excite the field at 45 volts DC delivered through the commutator, while the generator windings were intended to independently deliver 110-120 volts AC through the slip rings. The winding ratio between the exciter and generator windings was approximately one to three, and these are the values which determined the values employed in the present reduction to practice. However, it is to be understood that other values can be employed by design, for operation at the desired input and output voltages and amperages. It is also to be understood that the example reduction to practice disclosed herein is not necessarily the optimum design, in that other input-output power balances are contemplated, such as a DC battery input voltage substantially equal to the AC power voltage. In any case, an unexpected increase in power is realised by practising this invention.

This dynamo electric converter inherently operates at a substantially constant angular velocity with the result that the alternating cycles of the output are substantially constant. Also, the DC input voltage can be maintained at a substantially constant level with the result that the AC output voltage is also substantially constant. As shown, the output is single phase AC in which case the effective power in watts delivered is the product of current, voltage and power factor. Since the voltage is substantially constant, the current varies with load applied to the output as it is affected by the power factor. It will be seen therefore, that the apparent power represented by voltage times amperage is drawn directly from the DC input and applied to the primary motor winding **10** to motivate the rotor **R** for the functions previously described. It will also be seen therefore, that the DC input is commutated into AC and transformed by induction from windings **10** into windings **11**.

It will also be seen therefore, that the AC generated by motorisation of the motor is synchronously imposed upon the windings **11**, and all to the end that the two alternating currents are complementary and one added to the other. It will be observed that the output wattage is approximately triple the input wattage, by virtue of the synchronous superimposing of transformed input voltage and generated voltage while utilising the former to operate the rotor in order to generate the latter. A feature of this invention is the separation of the primary and secondary circuits and the consequent isolation of the inverted input DC from the outlet AC and the utilisation of input energy commensurate with output load according to amperage required for the operations to which this DEC machine is applied.

In carrying out this invention, the dynamo electric machine is conventional in design and the primary and secondary windings **10-11** are wound into the common slots of the armature as they are in self exciting generators. However, the primary windings **10** are motor-transformer windings and function totally as such. Similarly, the secondary windings **11** are wound into the armature slots together with the primary windings **10** and are powered with current that is alternated by virtue of the commutation and rotation of the armature, and consequently there is a transformer action between the primary windings **10** and secondary windings **11**, and this transformer function is supplemented by generation of a superimposed current by virtue of the secondary windings **11** cutting the magnetic lines of force provided by the surrounding stator field. Consequently, there is a multiplying of power synchronously applied through the slip rings **SR** to the output brushes **13**, and this increased output power is measurable as previously described and double or almost triple that of the input power.

METHOD

Referring now to this method of increasing electrical power, input alternating current is applied to a primary winding to both motor and alternately magnetise a core. The said primary winding is immersed in a field and consequently is caused to motor and simultaneously to perform the first stage of transforming. A second stage of transforming is then performed by a secondary winding associated with the core to function as both a transformer and a generator winding, and the output current is drawn from it at an increased power value as compared with the input power, since the current induced by transformer action is superimposed upon the current generated in

cutting the magnetic lines of force by motoring the secondary winding through the magnetic field. The direct application of AC power to the primary winding is contemplated, however the present and preferred embodiment employs commutation of DC power which is thereby inverted to AC power in the process of motoring the windings and the core in which they are carried together with the secondary winding. The net result is three fold, in that there is a motoring function, a transforming function, and a generating function, all of which are inherently synchronised to increase the output power with respect to the input power.

FIG. 1.

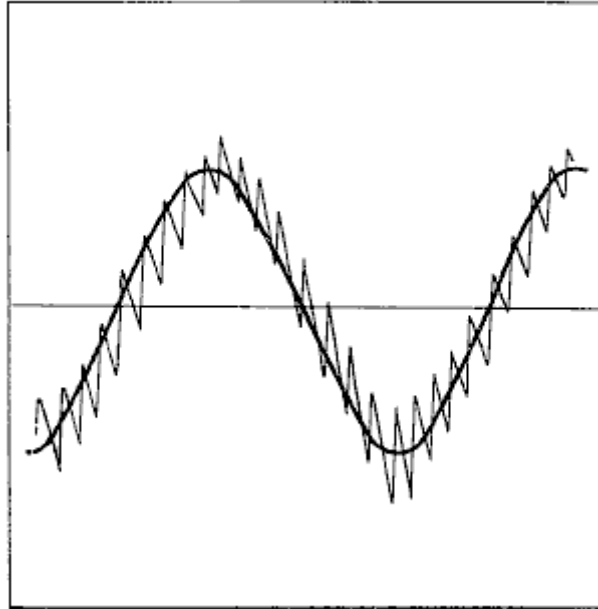

From the foregoing it will be seen that this method, and the dynamo-electric converter termed a DEC, synchronously superimposes transformed electrical energy and mechanically generated electrical energy when inverting DC to AC as is shown by observing the oscilloscope diagram duplicated in **Fig. 4** of the drawings. The DC motor section of the rotor-stator unit will operate at its designed speed well within a small tolerance, by applying known engineering principles, and consequently, the AC generator-alternator section will operate at a substantially uniform frequency of, for example, 60 cycles per second. Thus, the output voltage potential is kept to a maximum while current is drawn as required, within the design capacity of the unit.

Having described only a typical preferred form and application of my invention, I do not wish to be limited or restricted to the specific details herein set forth, but wish to reserve to myself any modifications or variations that may appear to those skilled in the art:

CLAIMS

1. A dynamo-electric converter for inverting direct current voltage to alternating current voltage and including; a magnetic field having poles of opposite polarity, an armature coaxial with the field and having a core with means to receive windings, coaxial bearing means between the field and the armature, a primary motor-transformer winding in said means of the armature core and a commutator connected therewith, direct current input brushes which can be engaged with the said commutator, a secondary transformer-generator winding in said means of the armature core and slip rings connected therewith, and alternating current output brushes which can be engaged with the said slip rings, whereby direct current input power is both transformed and regenerated as alternating output power.
2. The dynamo-electric converter as set forth in claim 1, wherein the magnetic field is a stator comprised of said poles of opposite polarity, and wherein the armature is a rotor supported upon said bearing means coaxially within said field.
3. The dynamo-electric converter as set forth in claim 1, wherein the means to receive windings is a pair of slots in the armature core, said primary and secondary windings being carried in the slots and subjected to the magnetic capabilities of the core.
4. The dynamo-electric converter as set forth in claim 1, wherein the means to receive windings is a multiplicity of slots disposed in a circumferential series about the armature core, said primary and secondary windings being

circumferentially progressive windings respectively and carried in common slots respectively and subjected to the magnetic capabilities of the core.

5. The dynamo-electric converter as set forth in claim 1, wherein the magnetic field poles are permanent magnets.
6. The dynamo-electric converter as set forth in claim 1, wherein the magnetic field poles are electro magnets energised separately from the said primary motor winding.
7. The dynamo-electric converter as set forth in claim 1, wherein the field poles are electro magnets energised in parallel with the direct current input brushes which can be engaged with the commutator.
8. The dynamo-electric converter as set forth in claim 1, wherein the magnetic field is a stator comprised of said poles of opposite polarity, wherein the armature is a rotor supported on said bearing means coaxially within said field, and wherein the means to receive windings is a pair of slots in the armature core, said primary and secondary windings being carried in the slots and subjected to the magnetic capabilities of the core.
9. The dynamo-electric converter as set forth in claim 1, wherein the magnetic field is a stator comprised of permanent magnet poles of opposite polarity, wherein the armature is a rotor supported on said bearing means coaxially within said field, and wherein the means to receive windings is a pair of slots in the armature core, said primary and secondary windings being carried in the slots and subjected to the magnetic capabilities of the core.
10. The dynamo-electric converter as set forth in claim 1, wherein the magnetic field is a stator comprised of permanent magnet poles of opposite polarity, wherein the armature is a rotor supported on said bearing means coaxially within said field, and wherein the means to receive windings is a multiplicity of slots disposed in a circumferential series about the armature core, said primary and secondary windings being circumferentially progressive windings and carried in common slots respectively and subjected to the magnetic capabilities of the core.
11. The dynamo-electric converter is set forth in claim 1, wherein the magnetic field poles are electro magnets of opposite polarity energised in parallel with the direct current input brushes which can be engaged with the commutator, wherein the means to receive windings is a multiplicity of slots disposed in a circumferential series about the armature core, said primary and secondary windings being circumferentially progressive windings respectively and carried in common slots respectively and subjected to the magnetic capabilities of the core.
12. A method for increasing electrical power and comprised of; placing a primary winding within the flux of a magnetic field and applying alternating current therethrough while motoring the same to revolve, simultaneously revolving a secondary winding with the primary winding and through a flux of a magnetic field, and simultaneously transforming the first mentioned alternating current from the primary winding and into the secondary winding while synchronously generating alternating current in the secondary winding.
13. The method of increasing electrical power as set forth in claim 12 wherein the magnetic field is held stationary and the primary and secondary windings revolved together.
14. The method of increasing electrical power as set forth in claim 12 wherein the primary and secondary windings are related to a common armature synchronously inducing into and generating electrical power through the secondary winding.
15. The method of increasing electrical power as set forth in claim 12 wherein the first mentioned alternating current is commutated from direct current to alternating current by revolvment of said primary winding.
16. The method of increasing electrical power as set forth in claim 12 wherein the magnetic field is held stationary and the primary and secondary windings revolved together and related to a common armature synchronously inducing into and generating electrical power through the secondary winding.
17. The method of increasing electrical power as set forth in claim 12 wherein the first mentioned alternating current is commutated from direct current to alternating current by revolvment of said primary winding and the primary and secondary windings related to a common armature synchronously inducing into and generating electrical power through the secondary winding.
18. The method of increasing electrical power as set forth in claim 12 wherein the first mentioned alternating current is commutated from direct current to alternating current by revolvment of said primary winding and wherein the magnetic field is held stationary and the primary and secondary windings revolved together and

related to a common armature synchronously inducing into and generating electrical power through the secondary winding.

- 19.** A dynamo-electric machine including; a first means applying a first alternating current into a primary motor-transformer winding, and a second means inducing a second alternating current into a secondary transformer-generator winding, said secondary winding being carried by said second means to operate through a flux of a field and thereby generating a third alternating current, whereby said second and third alternating currents are synchronously superimposed one upon the other.
- 20.** The dynamo-electric machine as set forth in claim 19 wherein the field is stationary and the primary and secondary windings are rotary.
- 21.** The dynamo-electric machine as set forth in claim 19 wherein the field is stationary and the primary and secondary windings are rotary with commutator bars synchronously applying a direct current to motorise the armature and to apply said first alternating current thereto.
- 22.** The dynamo-electric machine as set forth in claim 19 wherein the transformer means comprises magnetic core means common to the primary and secondary windings.
- 23.** The dynamo-electric machine as set forth in claim 19, wherein the field is stationary and the primary and secondary windings are rotary with commutator bars synchronously applying a direct current to motorise the armature and to apply said first alternating current thereto, and wherein the transformer means comprises magnetic core means common to the primary and secondary windings.
- 24.** A rotary dynamo-electric machine including: means applying alternating current through a primary motor-transformer winding carried by an armature core carrying a secondary transformer-generator winding, a field, and bearing means for rotation of the armature core relative to the field, whereby the alternating current applied to the primary winding motors the armature and is transformed and an alternating current generated and superimposed thereon through the secondary winding for increased output power.
- 25.** The rotary dynamo-electric machine as set forth in claim 24 wherein the primary and secondary windings are each comprised of a number of turns of conductor to transform the first mentioned applied alternating current to the voltage of the alternating current generated through the secondary winding.
- 26.** The rotary dynamo-electric motor as set forth in claim 24 wherein the first mentioned applied alternating current is of different voltage than the increased output power and wherein the primary and secondary windings are each comprised of a number of turns of conductor to transform the first mentioned applied alternating current to the voltage of the alternating current generated through the secondary winding.
- 27.** The rotary dynamo-electric machine as set forth in claim 24 wherein the first mentioned applied alternating current is of lower voltage than the increased output power and wherein the primary and secondary windings are each comprised of a number of turns of conductor to transform the first mentioned applied alternating current to the voltage of the alternating current generated through the secondary winding.

**INDUCTION GENERATOR HAVING A PAIR OF MAGNETIC POLES OF THE SAME POLARITY
OPPOSED TO EACH OTHER WITH RESPECT TO A ROTATION SHAFT**

This patent covers a device which is claimed to have a greater output power than the input power required to run it.

ABSTRACT

An induction generator having a pair of magnetic poles of the same polarity opposed to each other with respect to a rotation shaft is characterised by a high energy conversion efficiency. The induction generation has a rotation shaft driven by an external means; an even number of (more than three) stator cores provided to encircle the rotation shaft, predetermined gaps being provided between the adjacent stator cores; a first monopole rotor provided in the rotation shaft, surrounded by the even number of stator cores, and having first and second magnetic poles of the same polarity, the first and second magnetic poles being opposed to each other with respect to the rotation shaft in a cross section; a second monopole rotor provided in the rotation shaft so as to face the first monopole rotor at a predetermined distance along the rotation shaft, surrounded by the even number of stator cores, and having third and fourth magnetic poles of the same polarity opposite to the polarity of the first and second magnetic poles, the third and fourth magnetic poles being opposite to each other with respect to the rotation shaft; a plurality of windings provided in the even number of stator cores and connected according to a predetermined configuration.

US Patent References:

282472	Jan., 1883	Delaporte	318 / 197.
2982872	May., 1961	Fredrickson	310 / 163.
3858308	Jan., 1975	Peterson	29 / 598.
4780635	Oct., 1988	Neumann	310 / 216.
5030867	Jul., 1991	Yamada et al.	310 / 156.
5111095	May., 1992	Hendershot	310 / 168.
5402025	Mar., 1995	Saito et al.	310 / 156.

Other References:

Publication "Novel Reluctance Machine Concepts for Variable Speed Drives", Lipo, T.A., Proceedings from the Mediterranean Electrochemical Conference, Ljubljana, May 22-24, 1991, pp. 34-43.

DESCRIPTION

TECHNICAL FIELD

The present invention relates to an induction generator having a pair of magnetic poles of the same polarity opposed to each other with respect to a rotation shaft.

Induction generators have been known as one type of electrical appliance from relatively old days and embodied in various forms adapted for individual applications. In addition to applications in power plants, ships and aircraft, induction generators convenient for household or leisure purposes have also been developed and used extensively.

An induction generator converts kinetic energy into electric energy. Due to a necessity for improving efficiency of energy utilisation, there is a demand for a highly efficient energy conversion.

BACKGROUND ART

As is well known, an induction generator is operated on the principle that an electromotive force is induced in a coil, in proportion to the rate at which magnetic flux crosses that coil (Faraday's law of electromagnetic induction). According to Lenz's law, an induced electromotive force is generated in a direction in which a current that acts against a change in the magnetic flux is generated.

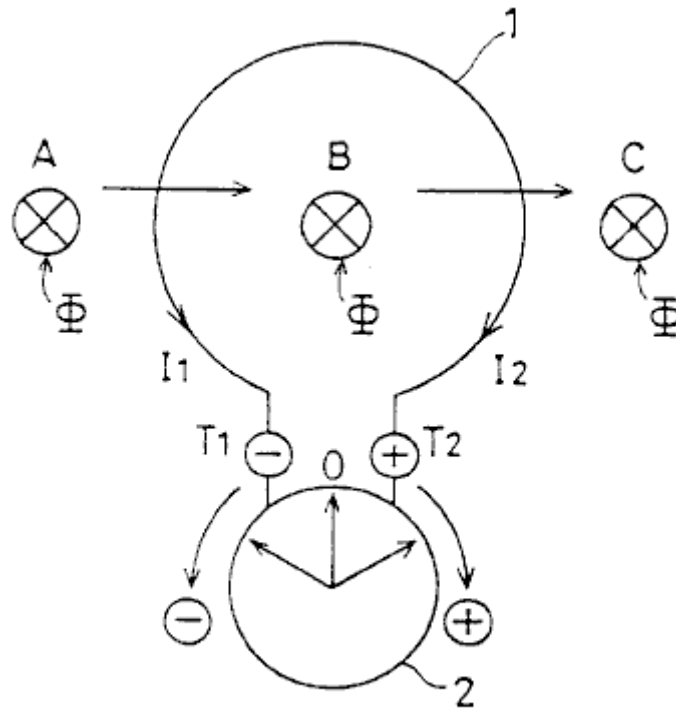

FIG. 1A

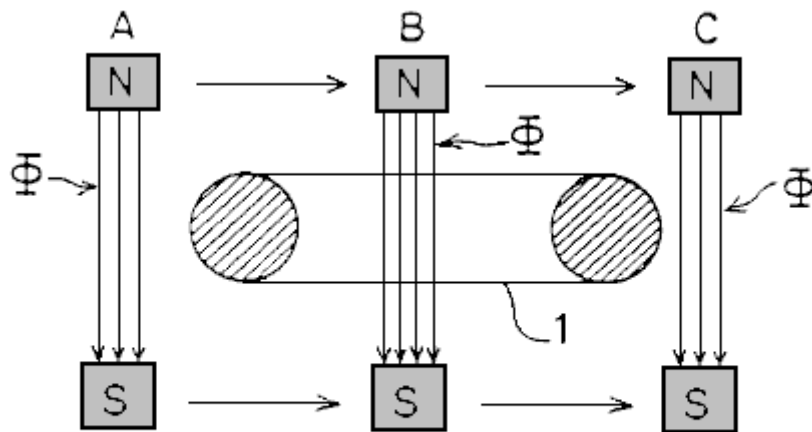

FIG. 1B

For example, as shown in **Fig.1A** and **Fig.1B**, assuming that the magnetic flux ϕ crossing a circular coil **1** at a perpendicular direction moves in the **A to B** direction as indicated by the arrow, a current I_1 flows in accordance with Faraday's law of electromagnetic induction so that the pointer of a galvanometer **2** swings clockwise (+ direction) and then returns to the zero position. When the magnetic flux ϕ moves in the direction **B to C**, a current I_2 flows so that the indicator of the galvanometer **2** swings counterclockwise (- direction) and then returns to the zero position.

Generally, an induction generator is constructed in such a way that an electromotive force is induced according to Fleming's right-hand rule by a conductor cutting magnetic flux lines (**Fig.1A**) or by the magnetic flux lines crossing the conductor (**Fig.1B**).

A rotor in an induction generator is usually constructed as a one-piece body having alternately disposed North poles and South poles. When there are two magnetic poles, the N-pole and the S-pole are opposite to each other. When there are more than two magnetic poles (for example, four magnetic poles or six magnetic poles etc.), the N-pole and the S-pole alternate, resulting in a N-S-N-S- . . . succession.

In this background, a unipolar induction generator is a special case wherein an electromotive force is generated by a conductor cutting the magnetic flux while moving or rotating, and a direct current is supplied through a slip

ring. In other words, a unipolar induction motor is unique in its construction characterised by a non-alternating magnetic field travelling in the same direction.

In the conventional induction generator such as the one described above, improvement in energy conversion efficiency is attained such that the rotor is constructed of a ferrite, or rare-earth, magnet characterised by a high energy product and a small reversing permeability (recoil permeability). Alternatively, the extent of demagnetisation due to generation of a counter magnetic field in an induction coil is reduced allowing the single polarity of the rotor to interact with the stator in forming a magnetic circuit. However, despite these measures, reduction in energy conversion efficiency due to a counter magnetic field of the rotor core, more specifically, due to demagnetisation resulting from the counter magnetic field caused by armature reaction presents a serious problem.

The present invention has been developed in view of the above points, and its object is to provide an induction generator having a pair of magnetic poles of the same polarity opposed to each other with respect to a rotation shaft, wherein a high energy conversion efficiency is attained.

DISCLOSURE OF THE INVENTION

The present invention provides an induction generator having a pair of magnetic poles of the same polarity opposed to each other with respect to a rotation shaft, characterised by comprising:

A rotation shaft driven by external means;

An even number of (more than three) stator cores provided to encircle the rotation shaft, predetermined gaps being provided between the adjacent stator cores;

A first single-opposed polarity rotor provided in the rotation shaft, surrounded by the even number of stator cores, and having first and second magnets magnetised such that the even number of stator cores remain facing a first polarity, the first and second magnets being opposed to each other with respect to the rotation shaft in a cross section;

A second single-opposed-polarity rotor provided in the rotation shaft so as to face the first single-opposed-polarity rotor at a predetermined distance along the rotation shaft, surrounded by the even number of stator cores, and having third and fourth magnets magnetised such that the even number of stator cores remain facing a second polarity which is opposite to the polarity of the first polarity, the third and fourth magnets being disposed opposite to each other with respect to the rotation shaft;

A plurality of windings provided in the even number of stator cores and connected according to a predetermined configuration, characterised in that:

A rotating magnetic field which causes electromagnetic induction in the even number of stator cores successively is created by the first, second, third and fourth magnets when the first and second single-opposed-polarity rotors are rotated; and

Periodic increase and decrease in the number of magnetic flux lines crossing a given winding and associated periodic decrease and increase crossing an adjacent winding causes a periodic electromotive force having a rectangular waveform to be output.

In one aspect of the present invention, the plurality of windings connected according to the predetermined configuration form first and second serial circuits:

The first serial circuit outputs a periodic first electromotive force having a rectangular waveform when a rotating magnetic field which causes electromagnetic induction in the even number of stator cores successively is created by the first, second, third and fourth magnets when the first and second single-opposed-polarity rotors are rotated; and

The second serial circuit outputs a periodic second electromotive force of a rectangular waveform 180° out of phase with the first electromotive force and having the same period as the first electromotive force, when a rotating magnetic field which causes electromagnetic induction in the even number of stator cores successively is created by the first and second single-opposed-polarity rotors are rotated.

The induction generator of the present invention may also comprise:

Rotation position detecting means for detecting a position of the first and second single-opposed-polarity rotors during their rotation; and

Switching means which alternately causes positive components of the first electromotive force having a rectangular waveform and provided by the first serial circuit, or positive components of the second electromotive force having a rectangular waveform and provided by the second serial circuit to be output at intervals of an electrical angle of 180° .

In another aspect of the present invention, the plurality of windings comprise a first winding provided in a first stator core of the even number of stator cores, a second winding provided in a second stator core adjacent to the first stator core so as to wind in a direction opposite to a direction in which the first winding is provided, a third winding provided in a third stator core adjacent to the second stator core so as to wind in the same direction as the first winding, a fourth winding provided in a fourth stator core adjacent to the third stator core so as to wind in a direction opposite to a direction in which the third winding is provided, the first through fourth windings being connected with each other according to a predetermined configuration.

In still another aspect of the present invention, the first serial circuit comprises a first winding provided to wind in a first direction in a first stator core of the even number of stator cores, a second winding serially connected to the first winding and provided in a second stator core adjacent to the first stator core so as to wind in a second direction opposite to the first direction, a third winding serially connected with the second winding and provided in a third stator core adjacent to the second stator core so as to wind in the first direction, a fourth winding serially connected to the third winding and provided in a fourth stator core adjacent to the third stator core so as to wind in the second direction; and

The second serial circuit comprises a fifth winding provided to wind in the second direction in the first stator core, a sixth winding serially connected to the fifth winding and provided in the second stator core so as to wind in the first direction, a seventh winding serially connected with the sixth winding and provided in the third stator core so as to wind in the second direction, an eighth winding serially connected to the seventh winding and provided in the fourth stator core so as to wind in the first direction.

In yet another aspect of the present invention, the first through fourth magnets are arc-shaped; and the even number of stator cores have arc-shaped cross sections.

In still another aspect of the present invention, the arc-shaped first through fourth magnets and the stator cores which have arc-like cross sections have an almost identical circumferential length.

BRIEF DESCRIPTION OF THE DRAWINGS

Fig.1A and **Fig.1B** are diagrams explaining the principle of an induction generator;

Fig.2A and **Fig.2B** are diagrams showing a first embodiment of the present invention;

Fig.3A and **Fig.3B** are diagrams showing a single-opposed-polarity rotor **11N** according to the first embodiment of the present invention;

Fig.4A and **Fig.4B** are diagrams showing a single-opposed-polarity rotor **11S** according to the first embodiment of the present invention;

Fig.5A, **Fig.5B** and **Fig.5C** are diagrams showing how wirings are connected with each other according to the first embodiment of the present invention;

Fig.6A is a diagram schematically showing how a rotating magnetic field according to the first embodiment crosses windings **7c-10c**;

Fig.6B shows a magnetic path;

Fig.7 is a diagram showing a waveform of an output voltage according to the first embodiment;

Fig.8A and **Fig.8B** are diagrams showing a second embodiment of the present invention;

Fig.9 is a diagram showing how wirings are connected with each other according to a second embodiment; and

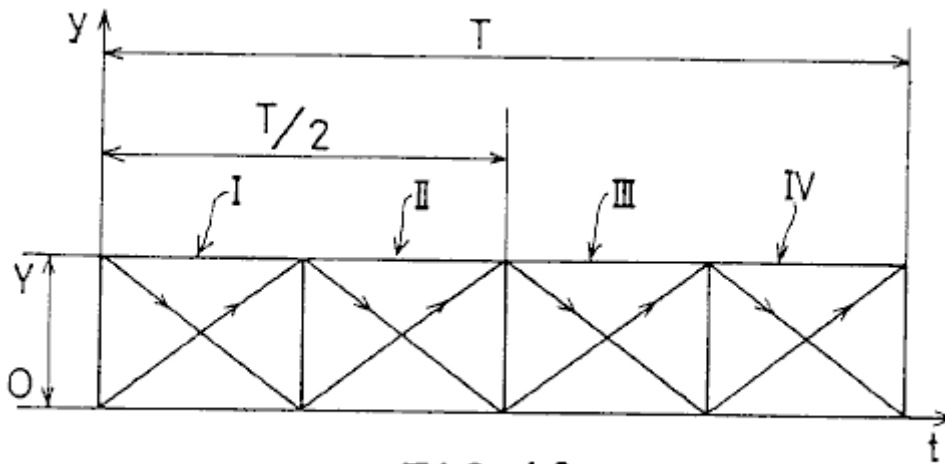

FIG. 10

Fig.10 is a diagram showing a waveform of an output voltage according to the second embodiment.

BEST MODE FOR CARRYING OUT THE INVENTION

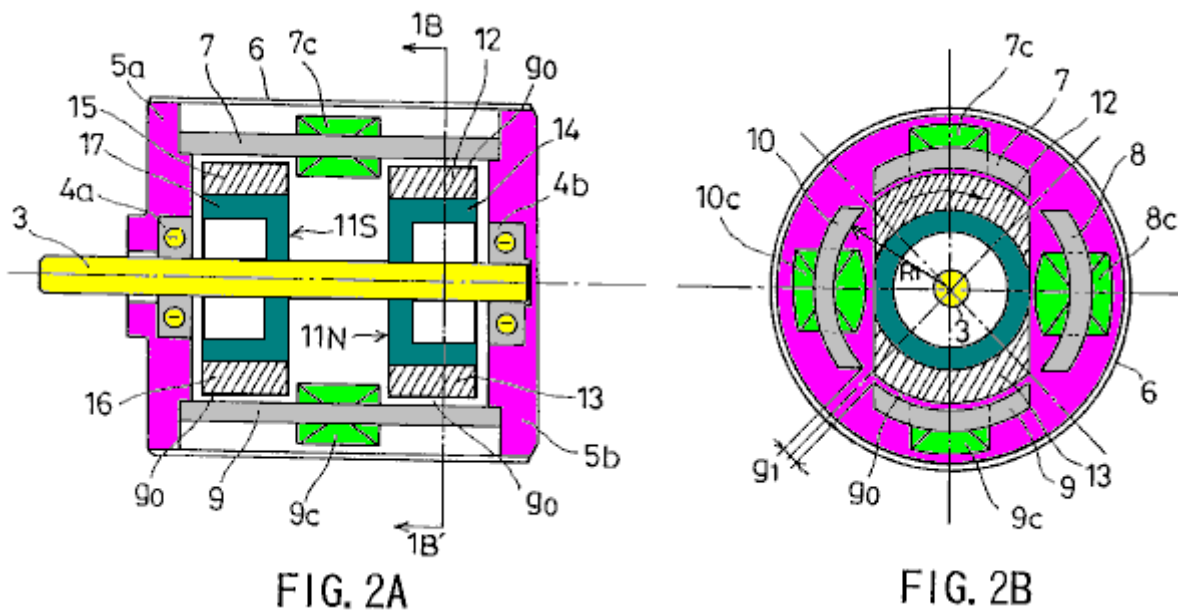

FIG. 2A

FIG. 2B

Fig.2A and Fig.2B show a first embodiment of the present invention. Specifically, Fig.2A is a longitudinal sectional view and Fig.2B is a cross-sectional view taken in the line 1B-1B' of Fig.2A.

Referring to Fig.2A and Fig.2B, 3 indicates a rotation shaft formed of a non-magnetic material and driven by an external means; 4a and 4b bearings for supporting the rotation shaft 3; 5a and 5b are flanges provided with the bearings 4a and 4b, respectively; and 6 is a cylindrical case cover for accommodating the flanges 5a and 5b.

Stator cores 7, 8, 9 and 10 are arranged so as to encircle the rotation shaft 3, equidistant gaps g_1 being provided between the adjacent stator cores. Each of the stator cores 7, 8, 9 and 10 has the same arc-like cross section.

A single-opposed-polarity N-pole rotor 11N and a single-opposed-polarity S-pole rotor 11S are provided on the rotation shaft 3 so as to be opposite to each other. The single-opposed-polarity rotors 11N and 11S are surrounded by the stator cores 7, 8, 9 and 10, a small rotation gap g_0 being provided between the single-opposed-polarity rotor and the stator core.

Referring to Fig.2B, windings 7c and 9c are provided clockwise around the stator cores 7 and 9, respectively. Windings 8c and 10c are wound counterclockwise around the stator cores 8 and 10, respectively. The windings 7c, 8c, 9c and 10c are connected with each other in a configuration described later.

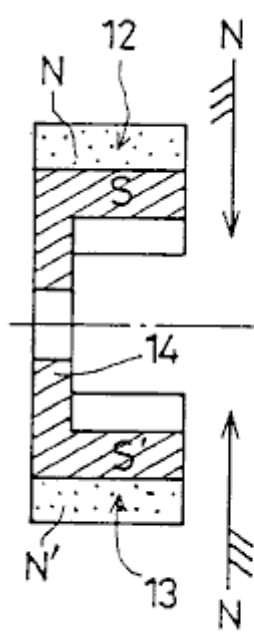

FIG. 3A

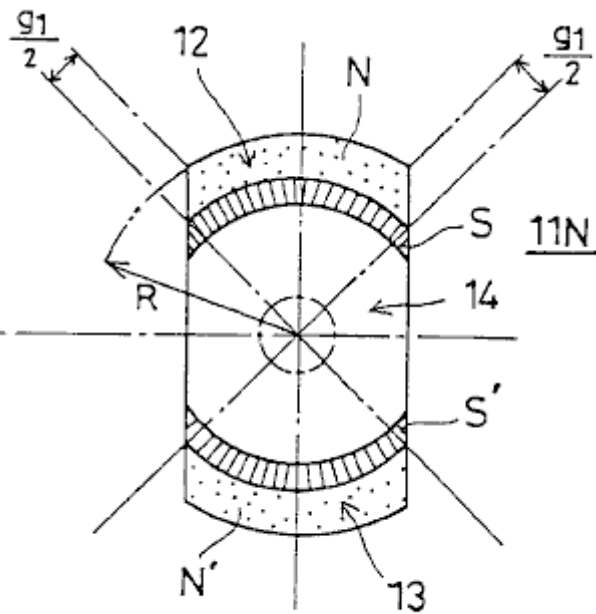

FIG. 3B

Fig.3A and Fig.3B show the single-opposed-polarity rotor 11N. Specifically, Fig.3A is a longitudinal sectional view, and Fig.3B is a cross-sectional view. The single-opposed-polarity rotor 11N has arc-shaped magnets 12 and 13 which are 180° displaced from each other and are magnetised such that their surfaces which face the stator cores 7-10 are N-poles while their inner surfaces are S-poles. The arc-shaped magnets 12 and 13 are configured to match the outline of the stator cores 7, 8, 9 and 10. Referring to Fig.3B, the symbols N and N' are used so as to differentiate between the magnets 12 and 13.

A rotor piece 14 is positioned so as to connect the arc-shaped magnets 12 and 13. The rotor piece 14 is magnetised by the arc-shaped magnets 12 and 13 so that its surfaces which face the arc-shaped magnets 12 and 13 are S-poles and is formed of a substance (for example, a silicon steel) constructed of a low carbon steel having mixed therein several percent of non-ferrous metal subjected to a forging-cast process. The iron core embodied by the rotor piece 14 thus constructed is characterised by a well-balanced magnetic field where the permeability approximates a peak value in a unipolar magnetic field that the iron core presents to its surroundings.

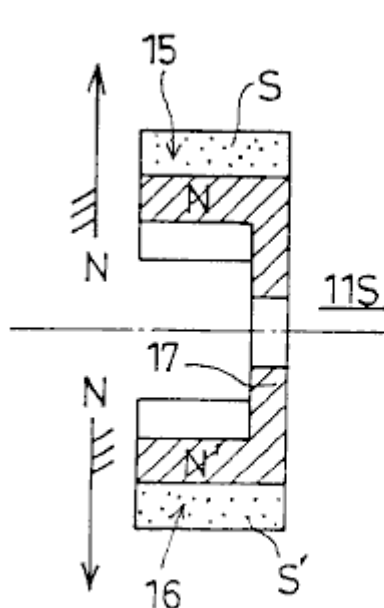

FIG. 4A

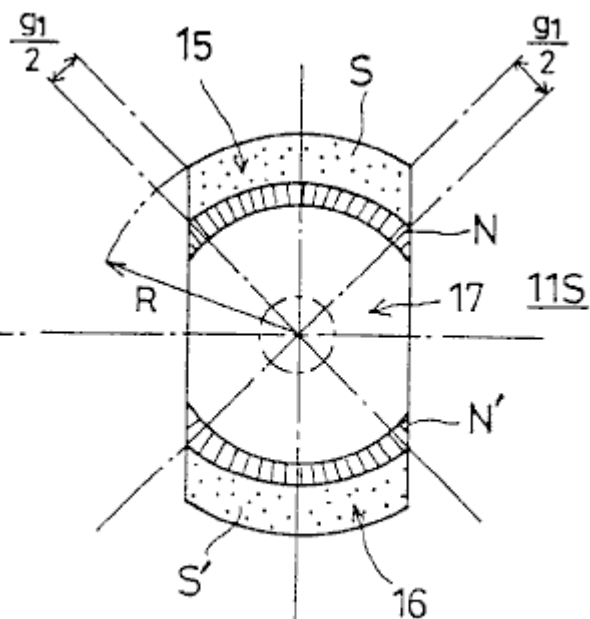

FIG. 4B

Fig.4A and **Fig.4B** show the single-opposed-polarity rotor **11S**. Specifically, **Fig.4A** is a longitudinal sectional view, and **Fig.4B** is a cross-sectional view.

The single-opposed-polarity rotor **11S** has arc-shaped magnets **15** and **16** which are 180° displaced from each other and are magnetised such that the surfaces thereof facing the stator cores **7-10** are S-poles while their inner surfaces are N-poles. The arc-shaped magnets **15** and **16** are configured to match the outline of the stator cores **7, 8, 9** and **10**.

A rotor piece **17** is positioned so as to connect the arc-shaped magnets **15** and **16**. The rotor piece **17** is magnetised by the arc-shaped magnets **15** and **16** so that its surfaces which face the arc-shaped magnets **15** and **16** are N-poles. The rotor piece is made from a substance constructed from a low carbon steel having mixed in it, several percent of non-ferrous metal subjected to a forging-cast process. The iron core embodied by the rotor piece **17** thus constructed is characterised by a well-balanced magnetic field where the permeability approximates a peak value in a unipolar magnetic field that the iron core presents to its surroundings.

The arc-shaped magnets **12, 13, 15** and **16** have the same circumferential length, which is also equal to the length of the arc formed by the circumference of the stator cores **7, 8, 9** and **10**. More specifically, this length is obtained by dividing the entire hypothetical circumference minus the four g_1 gaps by four. Referring to **Fig.2A** and **Fig.2B**, the rotation gap g_0 is equal to $R_1 - R$, where R_1 is a distance between the centre of the rotation shaft **3** and the inner surface of the stator cores **7-10**, and R is a distance between the centre of the rotation shaft **3** and the outer surface of the single-opposed-polarity rotors **11N** and **11S**, as indicated in **Fig.3B** and **Fig.4B**.

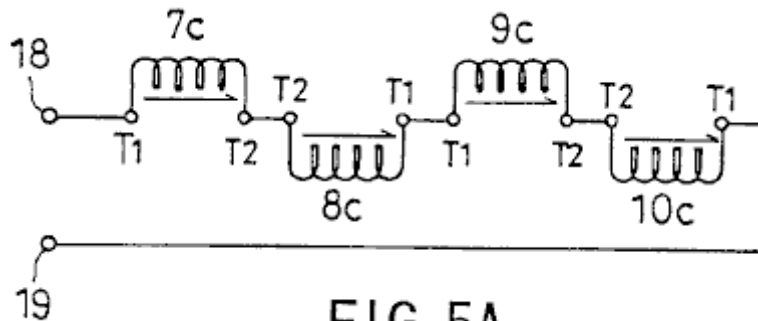

FIG. 5A

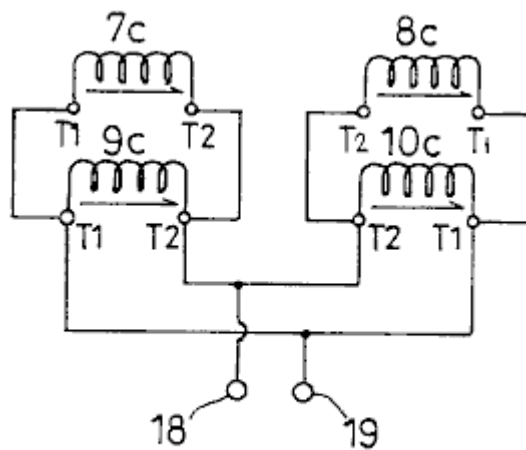

FIG. 5B

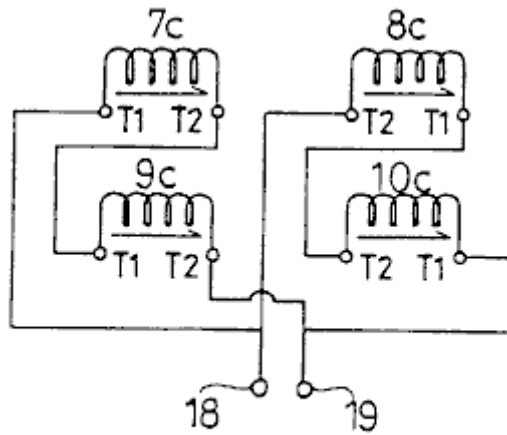

FIG. 5C

Fig.5A, Fig.5B and Fig.5C, show how the wirings are connected with each other. T₁ indicates the beginning of a winding, T₂ the end of a winding, and 18 and 19 output terminals. More specifically, Fig.5A shows a serial connection configuration, Fig.5B a serial-parallel connection configuration, and Fig.5C a parallel connection configuration. The serial connection configuration allows the electromotive force induced in the windings to be added together and provides a high-voltage output. The parallel connection configuration allows currents resulting from the electromotive force induced in the windings to be added together and provides a large-current output.

A description will now be given, with reference to Fig.6A, Fig.6B and Fig.7, of power generation operation of the serial connection configuration.

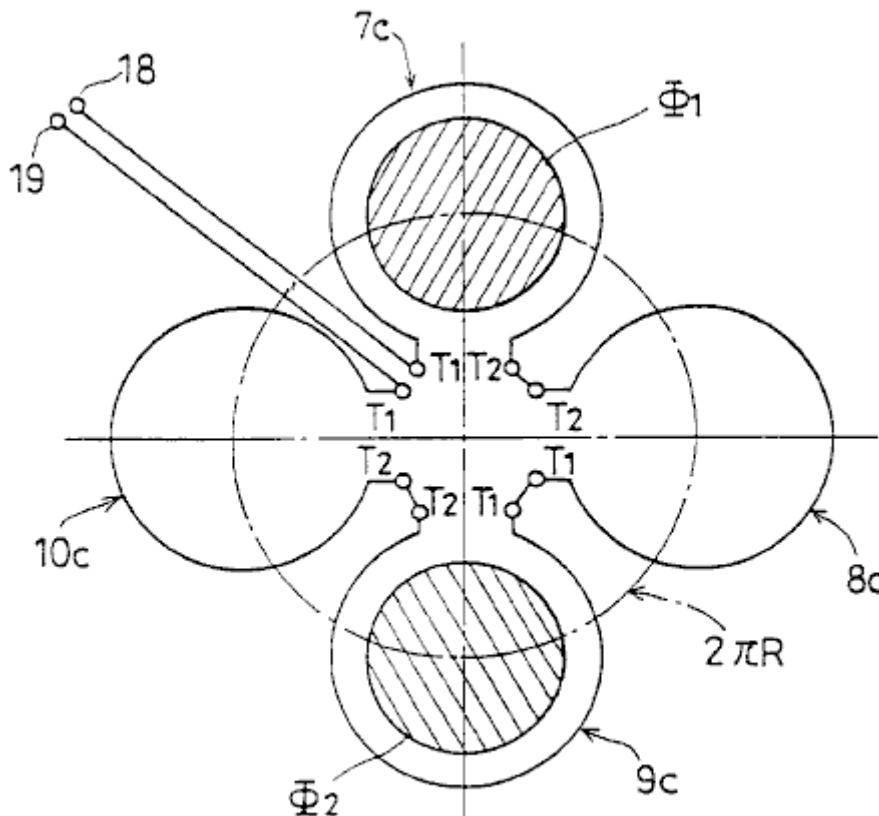

FIG. 6A

Fig.6A is a diagram showing schematically how the rotating magnetic field provided by the single-opposed-polarity rotors 11S and 11N crosses windings 7c-10c. Fig.6B shows a magnetic path.

Referring to Fig.6A, Φ_1 and Φ_2 indicate rotating magnetic flux rotating along the circumference $2\pi \times R$. Fig.6B shows the arc-shaped magnets 12 and 15 directly opposite the stator core 7 over their entire length, and the arc-shaped magnets 13 and 16 directly opposite the stator core 9 over their entire length.

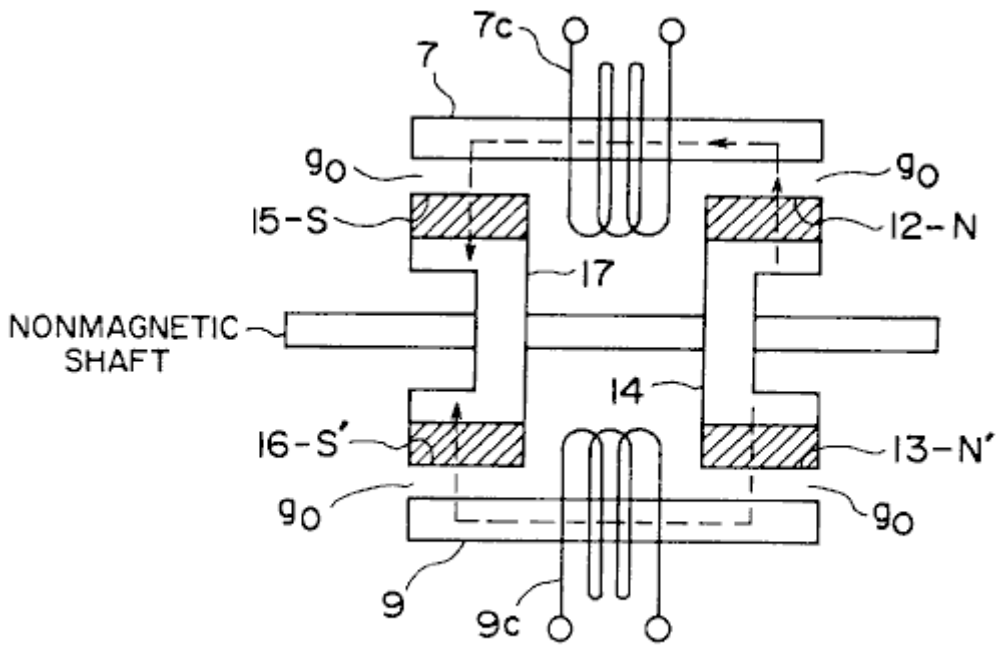

FIG. 6B

As shown in **Fig.6B**, the magnetic flux Φ_{i1} forms a magnetic path as follows:

The rotor piece **14** (S) - the arc-shaped magnet pole **12** (N) - stator core **7** - the rotation gap g_0 - the arc-shaped magnet **15** (S) - the rotor piece **17** (N).

The magnetic flux Φ_{i2} forms a magnetic path as follows:

The rotor piece **14** (S) - the arc-shaped magnet **13** (N) - the rotation gap g_0 - the stator core **9** - the rotation gap g_0 - the arc-shaped magnet **16** (S) - the rotor piece **17** (N).

Thus, a parallel magnetic path is formed. In this state, the magnetic flux Φ_{i1} crosses the winding **7c**, and the magnetic flux Φ_{i2} crosses the winding **9c**.

A description focused on the rotation of the magnetic flux Φ_{i1} is given. Specifically, a description will be given of a change in the way the magnetic flux Φ_{i1} crosses the windings.

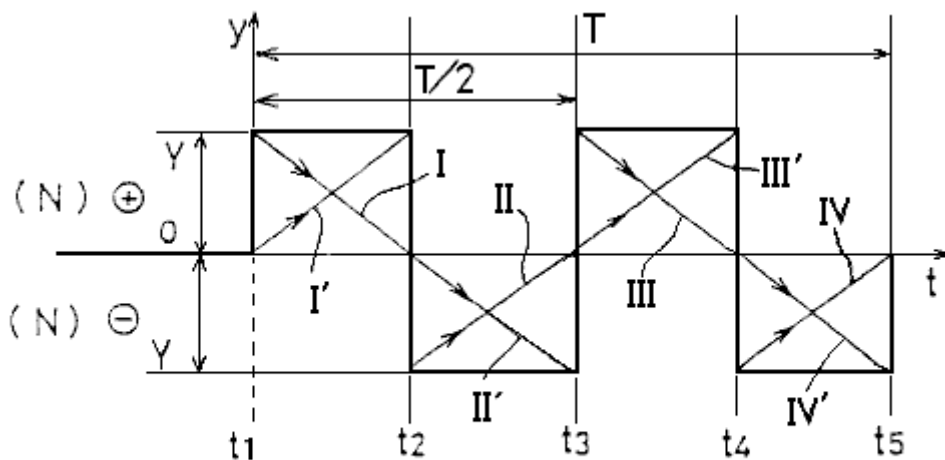

FIG. 7

Referring to a waveform of an output voltage shown in **Fig.7**, the entirety of the magnetic flux **Phi₁** crosses the winding **10c** at a time **t₁**. At a time **t₂**, the entirety of the magnetic flux **Phi₁** crosses the winding **7c**. At a time **t₃**, the entirety of the magnetic flux **Phi₁** crosses the winding **8c**. At a time **t₄**, the entirety of the magnetic flux **Phi₁** crosses the winding **9c**. At a time **t₅**, the entirety of the magnetic flux **Phi₁** crosses the winding **10c**. In this way, the magnetic flux **Phi₁** rotates at a constant speed during a time **T**, in a clockwise direction in **Fig.6A**.

Between the time **t₁** and the time **t₂**, an electromotive force having a descending triangular waveform, indicated by **I** in **Fig.7**, is generated in the winding **10c** due to a decrease in the number of magnetic flux lines of the magnetic flux **Phi** crossing the winding **10c**. An electromotive force having an ascending triangular waveform, indicated by **I'** in **Fig.6**, is generated in the winding **7c** due to an increase in the number of magnetic flux lines of the magnetic flux **Phi** crossing the winding **7c**. Accordingly, a positive rectangular waveform obtained by the sum of these triangular waveforms is output to the output terminals **18** and **19**.

Between the time **t₂** and the time **t₃**, an electromotive force having an ascending triangular waveform, indicated by **II** in **Fig.7**, is generated in the winding **7c** due to a decrease in the number of magnetic flux lines of the magnetic flux **Phi** crossing the winding **7c**. An electromotive force having a descending triangular waveform, indicated by **II'** in **Fig.7**, is generated in the winding **8c** due to an increase in the number of magnetic flux lines of the magnetic flux **Phi** crossing the winding **8c**. Accordingly, a negative rectangular waveform obtained by the sum of these triangular waveforms is output to the output terminals **18** and **19**.

Between the time **t₃** and the time **t₄**, an electromotive force having a descending triangular waveform, indicated by **III** in **Fig.7**, is generated in the winding **8c** due to a decrease in the number of magnetic flux lines of the magnetic flux **Phi** of the magnetic flux **Phi** crossing the winding **8c**. An electromotive force having an ascending triangular waveform, indicated by **III'** in **Fig.7**, is generated in the winding **9c** due to an increase in the number of magnetic flux lines of the magnetic flux **Phi** crossing the winding **9c**. Accordingly, a positive rectangular waveform obtained by the sum of these triangular waveforms is output to the output terminals **18** and **19**.

Between the time **t₄** and the time **t₅**, an electromotive force having an ascending triangular waveform, indicated by **IV** in **Fig.7**, is generated in the winding **9c** due to a decrease in the number of magnetic flux lines of the magnetic flux **Phi** crossing the winding **9c**. An electromotive force having a descending triangular waveform, indicated by **IV'** in **Fig.7**, is generated in the winding **10c** due to an increase in the number of magnetic flux lines of the magnetic flux **Phi** crossing the winding **10c**. Accordingly, a negative rectangular waveform obtained by the sum of these triangular waveforms is output to the output terminals **18** and **19**.

While the magnetic flux **Phi₁** makes one rotation, an electromotive force having a synthesised rectangular waveform and a period of **T/2** is output, as shown in **Fig.7**. Since the magnetic flux **Phi₂** also makes one rotation while the magnetic flux **Phi₁** makes one rotation and produces an output of an electromotive force having a similar rectangular waveform, the magnitude of the electromotive force obtained between the terminals **18** and **19** is actually double that indicated in **Fig.7**.

In this way, this embodiment makes it possible to cancel a counter magnetic field and provide an induction generator having a pair of magnetic poles of the same polarity opposed to each other with respect to a rotation shaft and characterised by a high energy conversion efficiency. Our operating practice has confirmed that the generator having the construction of this embodiment provides an energy conversion efficiency which is high enough to require only 1/5.2 of the driving torque for the conventional generator.

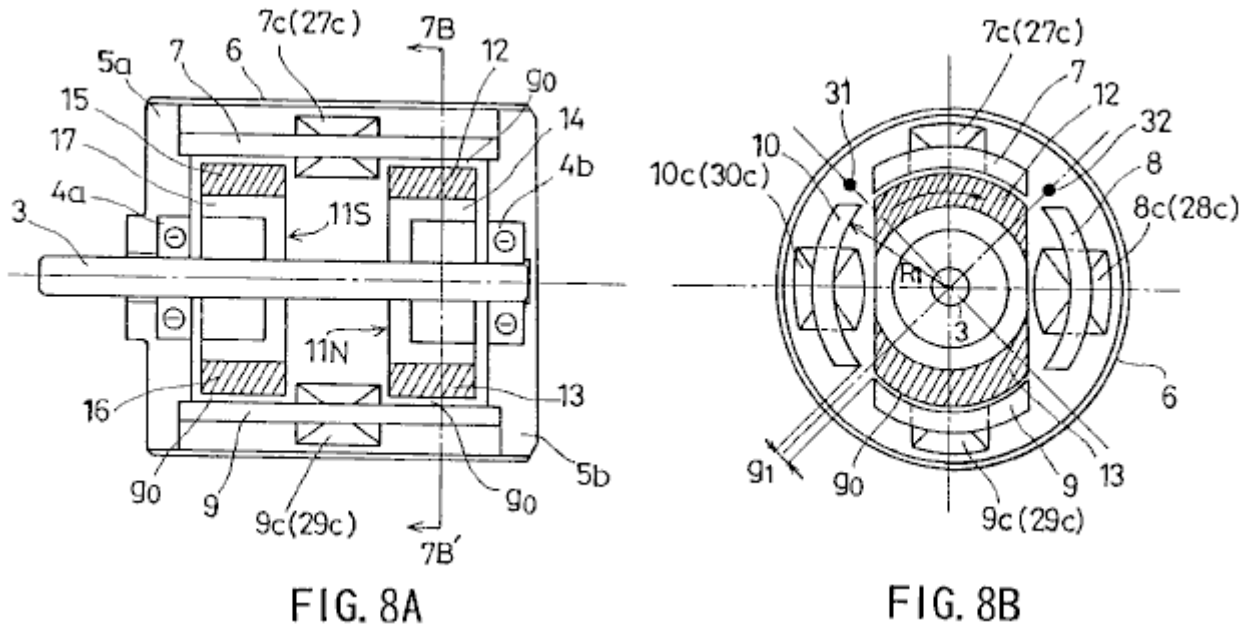

Fig.8A and **Fig.8B** show a second embodiment of the present invention. Specifically, **Fig.8A** is a longitudinal sectional view, and **Fig.8B** is a cross-sectional view taken in the line **7B-7B'** of **Fig.8A**.

Referring to **Fig.8A** and **Fig.8B**, **3** indicates a rotation shaft formed of a non-magnetic material and driven by an external source; **4a** and **4b** are bearings which support the rotation shaft **3**, **5a** and **5b** are flanges housing the bearings **4a** and **4b**, and **6** is a cylindrical case cover for accommodating the flanges **5a** and **5b**.

Stator cores **7**, **8**, **9** and **10** are arranged so as to encircle the rotation shaft **3**, equidistant gaps **g₁** being provided between the adjacent stator cores. Each of the stator cores **7**, **8**, **9** and **10** has a same arc-like cross section.

A single-opposed-polarity N-pole rotor **11N** and a single-opposed-polarity S-pole rotor **11S** are provided on the rotation shaft **3** so as to be opposite to each other. The single-opposed-polarity rotors **11N** and **11S** are surrounded by the stator cores **7**, **8**, **9** and **10** a small rotation gap **g₀** being provided between the single-opposed-polarity rotor and the stator core.

Referring to **Fig.8B**, windings **7c** and **9c** are provided clockwise around the stator cores **7** and **9**, respectively. Windings **27c** and **29c** are provided counterclockwise around the stator cores **7** and **9**, respectively. Windings **8c** and **10c** are provided counterclockwise in the stator cores **8** and **10**, respectively. Windings **28c** and **30c** are wound clockwise around the stator cores **8** and **10**, respectively. The windings **7c**, **8c**, **9c**, **10c**, **27c**, **28c**, **29c** and **30c** are connected with each other according to a configuration described later.

A magnetic sensor (for rotation position detection) **31** is provided between the stator cores **7** and **10**, and a magnetic sensor (for rotation position detection) **32** is provided between the stator cores **7** and **8**. The magnetic sensors **31** and **32** detect the magnetic field so as to determine the position of the single-opposed-polarity rotors **11N** and **11S** during their rotation.

The single-opposed-polarity rotors **11N** has a configuration as shown in **Fig.3A** and **Fig.3B**, and the monopole rotor **11S** has a configuration as shown in **Fig.4A** and **Fig.4B**.

The single-opposed-polarity rotor **11N** has arc-shaped magnets **12** and **13** which are 180⁰ displaced from each other and are magnetised such that their surfaces facing the stator cores are N-poles while their respective inner surfaces are S-poles. The arc-shaped magnets **12** and **13** are configured to match the outline of the stator cores **7**, **8**, **9** and **10**.

A rotor piece **14** is positioned so as to connect the arc-shaped magnets **12** and **13**. The rotor piece **14** is constructed from a low-carbon steel having several percent of non-ferrous metal, using a forging-cast process. The iron core rotor piece **14** constructed by this means, has a well-balanced magnetic field where the permeability approximates a peak value in a unipolar magnetic field that the iron core presents to its surroundings.

The single-opposed-polarity rotor **11S** has arc-shaped magnets **15** and **16** which are positioned 180⁰ apart from each other and are magnetised so that their surfaces which face the stator cores are S-poles while their inner

surfaces are N-poles. The arc-shaped magnets **15** and **16** are shaped and positioned so as to match the outline of the stator cores **7**, **8**, **9** and **10**.

A rotor piece **17** is positioned so as to connect the arc-shaped magnets **15** and **16**. The rotor piece **17** is constructed from a low-carbon steel having several percent of non-ferrous metal, using a forging-cast process. The iron core rotor piece **17** constructed by this means, has a well-balanced magnetic field where the permeability approximates a peak value in a unipolar magnetic field which the iron core presents to its surroundings.

The arc-shaped magnets **12**, **13**, **15** and **16** have the same circumferential lengths, which is equal to the length of the arc formed by the circumference of the stator cores **7**, **8**, **9** and **10**. More specifically, this length is obtained by dividing by four, the entire hypothetical circumference minus the four gaps g_1 . Referring to **Figs. 3A**, **3B**, **4A**, **4B** and **8**, the rotation gap g_0 is equal to $R_1 - R$.

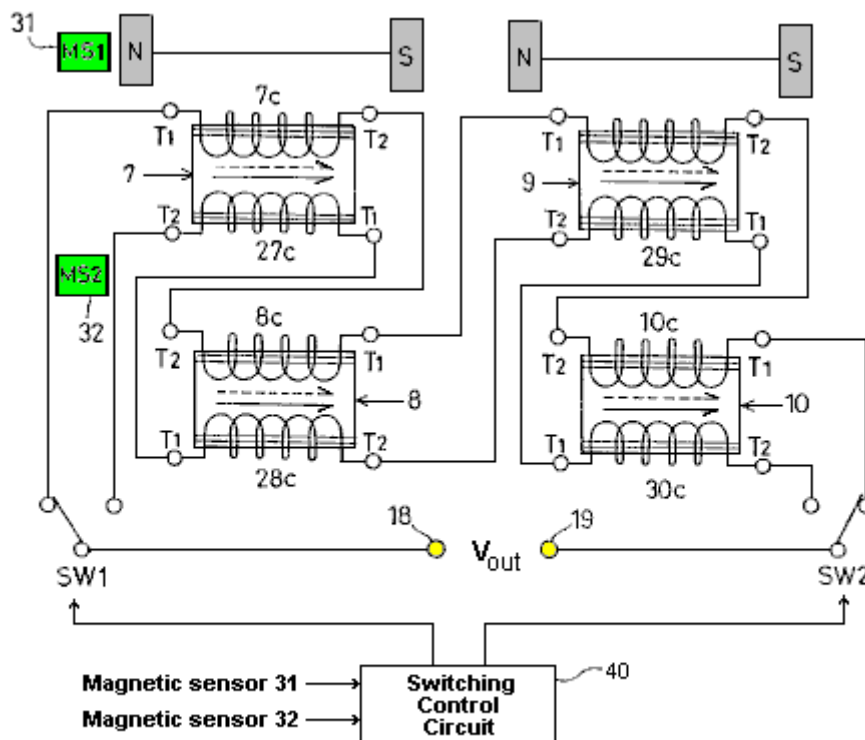

FIG. 9

Fig.9 shows how the wirings are connected with each other. T_1 indicates the beginning of a winding, T_2 the end of a winding, and **18** and **19** are the output terminals.

Two serial circuits are formed out of the windings. Switches **SW1** and **SW2** are used for selection of the respective serial circuits. A switching control circuit **40**, which processes a detection signal from the magnetic sensors **31** and **32**, drives the switches **SW1** and **SW2** selectively in accordance with the detection signal.

As shown in **Fig.9**, the first serial circuit comprises the winding **7c** provided clockwise in the stator core **7**, the winding **8c** serially connected with the winding **7c** and provided counterclockwise in the stator core **8** adjacent to the stator core **7**; the winding **9c** serially connected with the winding **8c** and provided clockwise in the stator core **9**; and the winding **10c** serially connected with the winding **9c** and provided counterclockwise in the stator core **10** adjacent to the stator core **9**.

As shown in **Fig.9**, the second serial circuit comprises the winding **27c** provided counterclockwise in the stator core **7**; the winding **28c** serially connected with the winding **27c** and provided clockwise in the stator core **8**; the winding **29c** serially connected with the winding **28c** and provided counterclockwise in the stator core **9**; and the winding **30c** serially connected with the winding **29c** and provided clockwise in the stator core **10**.

According to the construction described above, a rotating magnetic field which causes electromagnetic induction in the stator cores **7-10** successively is created by the arc-shaped magnets **12**, **13**, **15** and **16** when the single-opposed-polarity rotors **11N** and **11S** are rotated. As has been already explained with reference to **Fig.6A**, **Fig.6B** and **Fig.7**, as the magnetic flux lines crossing one of the windings **7c-10c** increase in number, the magnetic flux lines crossing the adjacent one of the windings **7c-10c** decrease in number. That is, the magnetic

flux lines periodically increase and decrease with respect to a given winding so that a first electromotive force, having a rectangular waveform similar to the one shown in **Fig.7** and a period that is 1/2 the period of the rotation, is output from the first serial circuit (**7c-10c**).

As the magnetic flux lines crossing one of the windings **27c-30c** increase in number, the magnetic flux lines crossing the adjacent one of the windings **27c-30c** decrease in number. That is, the magnetic flux lines periodically increase and decrease with respect to a given winding so that a second electromotive force of a rectangular waveform 180° out of phase with the first electromotive force and having the same period as the first electromotive force is output from the second serial circuit (**27c-30c**). That is, the second electromotive force is 180° out of phase with the electromotive force shown in **Fig.7**.

Referring to **Fig.10**, in accordance with the detection signal from the magnetic sensors **31** and **32**, the switches **SW1** and **SW2** effect switching at 90° intervals. By that means, the positive components **I** and **III** of the first electromotive force having a rectangular waveform and provided from the first serial circuit, and the positive components **II** and **IV** of the second electromotive force having a rectangular waveform and provided from the second serial circuit are alternately selected at 180° intervals and output to the output terminals **18** and **19**.

This means that, this embodiment ensures a high-efficiency energy conversion wherein a counter magnetic field is cancelled, and a DC electromotive force having a positive level is properly synthesised and output. It is of course possible to synthesise and output a negative DC electromotive force by shifting the switching timing by 180° .

INDUSTRIAL APPLICABILITY

As has been described, according to the present invention, the rotation of the first and second single-opposed-polarity rotors generates a rotating magnetic field which causes an induction in an even number of stator cores successively. As the magnetic flux lines crossing one of the first-through-fourth windings increase in number, the magnetic flux lines crossing the adjacent one of the first-through-fourth windings decrease in number. That is, the magnetic flux lines periodically increase and decrease with respect to a given winding. The electromotive force generated as the magnetic flux lines crossing a winding increase in number and the electromotive force generated as the magnetic flux lines crossing an adjacent winding decrease in number are synthesised so that a periodic AC electromotive force having a rectangular waveform is generated out of the synthesis and output. In this way, a high-efficiency energy conversion wherein a counter magnetic field is cancelled is provided.

According to the first serial circuit of the present invention, the rotation of the first and second single-opposed-polarity rotors generates a rotating magnetic field which causes an induction in an even number of stator cores successively. As the magnetic flux lines crossing one of the first through fourth windings increase in number, the magnetic flux lines crossing the adjacent one of the first through fourth windings decrease in number. That is, the magnetic flux lines periodically increase and decrease in a given winding. Accordingly, the first electromotive force having a rectangular waveform is output. According to the second serial circuit, as the magnetic flux lines crossing one of the fifth-through-eighth windings increase in number, the magnetic flux lines crossing the adjacent one of the fifth-through-eighth windings decrease in number. That is, the magnetic flux lines periodically increase and decrease in a given winding. Accordingly, the second electromotive force 180° out of phase with the first electromotive force and having the same period as the first electromotive force is output. In accordance with the detection signal from the rotation position detecting means, the switching means selectively causes the positive components of the first electromotive force provided by the first serial circuit, or the positive components of the second electromotive force provided by the second serial circuit to be output at 180° intervals. In this way the DC electromotive force is synthesised and output. This results in a high-efficiency energy conversion where a counter magnetic field is cancelled.

In addition to extensive applications in power plants, ships, aircraft etc., the present invention may find household applications or may be conveniently adapted for leisure uses.

CLAIMS

1. An induction generator having a pair of magnetic poles of the same polarity opposed to each other with respect to a rotation shaft, characterised by comprising:

a rotation shaft driven by external means;

an even number of (more than three) stator cores provided to encircle said rotation shaft, predetermined gaps being provided between the adjacent stator cores;

a first single-opposed-polarity rotor provided on said rotation shaft, surrounded by said even number of stator cores, and having first and second magnets magnetised such that said even number of stator cores remain facing a first polarity, said first and second magnets sandwiching a magnetic body between them and being opposed to each other with respect to said rotation shaft in a cross section;

a second single-opposed-polarity rotor provided on said rotation shaft so as to face said first single-opposed-polarity rotor at a predetermined distance along the rotation shaft, surrounded by said even number of stator cores, and having third and fourth magnets magnetised such that said even number of stator cores remain facing a second polarity which is opposite to the polarity of said first polarity, said third and fourth magnets sandwiching a magnetic body between them and being disposed opposite to each other with respect to said rotation shaft;

a plurality of windings provided in said even number of stator cores and connected according to a predetermined configuration, characterised in that: a rotating magnetic field which causes electromagnetic induction in said even number of stator cores successively is created by the first, second, third and fourth magnets when said first and second single-opposed-polarity rotors are rotated; and

two windings adjacent to each other are wound in opposite directions and connected in series so that a rectangular waveform is formed by synthesising the electromotive forces generated by the two windings, so that an electromotive force having a triangular waveform caused by periodic increase and decrease in the number of magnetic flux lines crossing one of the two windings and another electromotive force having a triangular waveform caused by associated periodic decrease and increase in the number of magnetic flux lines crossing the other one of the windings are synthesised so as to generate a periodic voltage having a rectangular waveform.

2. The induction generator having a pair of magnets of the same polarity opposed to each other with respect to a rotation shaft as claimed in claim 1, characterised in that:

said plurality of windings connected according to the predetermined configuration form first and second serial circuits;

said first serial circuit outputs a periodic first electromotive force having a rectangular waveform when a rotating magnetic field which causes electromagnetic induction in said even number of stator cores successively is created by said first, second, third and fourth magnets when said first and second single-opposed-polarity rotors are rotated; and

said second serial circuit outputs a periodic second electromotive force of a rectangular waveform 180° out of phase with the first electromotive force and having the same period as the first electromotive force, when a rotating magnetic field which causes electromagnetic induction in said even number of stator cores successively is created by said first and second single-opposed-polarity rotors are rotated.

3. The induction generator having a pair of magnets of the same polarity opposed to each other with respect to a rotation shaft as claimed in claim 2, further comprising:

rotation position detecting means for detecting a position of said first and second single-opposed-polarity rotors during their rotation; and

switching means which alternately causes positive components of said first electromotive force having a rectangular waveform and provided by said first serial circuit, or positive components of said second electromotive force having a rectangular waveform and provided by said second serial circuit to be output at intervals of an electrical angle of 180° to thereby produce a DC output.

4. The induction generator having a pair of magnets of the same polarity opposed to each other with respect to a rotation shaft as claimed in claim 1, characterised in that:

said plurality of windings comprise a first winding provided in a first stator core of said even number of stator cores, a second winding provided in a second stator core adjacent to the first stator core so as to wind in a direction opposite to a direction in which the first winding is provided, a third winding provided in a third stator core adjacent to the second stator core so as to wind in the same direction as the first winding, a fourth winding provided in a fourth stator core adjacent to the third stator core so as to wind in a direction opposite to a direction in which the third winding is provided, the first through fourth windings being connected with each other according to a predetermined configuration.

- 5.** The induction generator having a pair of magnets of the same polarity opposed to each other with respect to a rotation shaft as claimed in claim 2, characterised in that:

said first serial circuit comprise a first winding provided to wind in a first direction in a first stator core of said even number of stator cores, a second winding serially connected to said first winding and provided in a second stator core adjacent to the first stator core so as to wind in a second direction opposite to the first direction, a third winding serially connected with said second winding and provided in a third stator core adjacent to the second stator core so as to wind in the first direction, a fourth winding serially connected to said third winding and provided in a fourth stator core adjacent to the third stator core so as to wind in the second direction; and

said second serial circuit comprises a fifth winding provided to wind in the second direction in said first stator core, a sixth winding serially connected to said fifth winding and provided in said second stator core so as to wind in said first direction, a seventh winding serially connected with said sixth winding and provided in said third stator core so as to wind in said second direction, an eighth winding serially connected to said seventh winding and provided in said fourth stator core so as to wind in said first direction.

- 6.** The induction generator having a pair of magnets of the same polarity opposed to each other with respect to a rotation shaft as claimed in claim 1, characterised in that:

said first through fourth magnets are arc-shaped; and

said even number of stator cores have arc-shaped cross sections.

- 7.** The induction generator having a pair of magnets of the same polarity opposed to each other with respect to a rotation shaft as claimed in claim 6, characterised in that said arc-shaped first through fourth magnets and said stator cores which have arc-shaped cross sections have an almost identical circumferential length.

- 8.** The induction generator having a pair of magnets of the same polarity opposed to each other with respect to a rotation shaft as claimed in claim 2, characterised in that:

said first through fourth magnets are arc-shaped; and

said even number of stator cores have arc-shaped cross sections.

- 9.** The induction generator having a pair of magnets of the same polarity opposed to each other with respect to a rotation shaft as claimed in claim 3, characterised in that:

said first through fourth magnets are arc-shaped; and

said even number of stator cores have arc-shaped cross sections.

- 10.** The induction generator having a pair of magnets of the same polarity opposed to each other with respect to a rotation shaft as claimed in claim 4, characterised in that:

said first through fourth magnets are arc-shaped; and

said even number of stator cores have arc-shaped cross sections.

- 11.** The induction generator having a pair of magnetic poles of the same polarity opposed to each other with respect to a rotation shaft as claimed in claim 5, characterised in that:

said first through fourth magnets are arc-shaped; and

said even number of stator cores have arc-shaped cross sections.

- 12.** The induction generator having a pair of magnetic poles of the same polarity opposed to each other with respect to a rotation shaft as claimed in claim 8, characterised in that said arc-shaped first through fourth magnets and said stator cores which have arc-shaped cross sections have an almost identical circumferential length.

- 13.** The induction generator having a pair of magnetic poles of the same polarity opposed to each other with respect to a rotation shaft as claimed in claim 9, characterised in that said arc-shaped first through fourth magnets and said stator cores which have arc-shaped cross sections have an almost identical circumferential length.

14. The induction generator having a pair of magnetic poles of the same polarity opposed to each other with respect to a rotation shaft as claimed in claim 10, characterised in that said arc-shaped first through fourth magnets and said stator cores which have arc-shaped cross sections have an almost identical circumferential length.
15. The induction generator having a pair of magnetic poles of the same polarity opposed to each other with respect to a rotation shaft as claimed in claim 11, characterised in that said arc-shaped first through fourth magnets and said stator cores which have arc-shaped cross sections have an almost identical circumferential length.

ENERGY SOURCE EMPLOYING ELECTRICAL ENERGISER

This patent application shows the details of a device which it is claimed, can produce electricity without the need for any fuel. It should be noted that while construction details are provided which imply that the inventor constructed and tested several of these devices, this is only an application and not a granted patent.

ABSTRACT

An energy producing system is provided which produces energy for use, for example, in an electric vehicle or in a home power plant. The system includes an electrical energiser (60) including a double-wound rotor and a double-wound stator, for producing electrical energy which is stored in the system, e.g. in a battery (66) storage arrangement, which provides initial energisation of the system. the stored energy is supplied to an electric motor (68) which drives the energiser (60) to thereby create additional energy. the energiser is able to supply the needs of the system as well as to power a load.

BACKGROUND OF THE INVENTION

The present invention relates to energy producing systems and, more particularly, to an electrical energiser-motor system for providing energy, e.g., for an automotive vehicle or as part of a home energy plant.

With the advent of the so-called "energy crisis" and the consequent search for alternative energy sources to substitute for oil, considerable attention has been focused on automotive vehicles as chief users of oil products. One aspect of this search has fostered renewed interest in electrically driven vehicles such as electric cars and the like. A principal shortcoming of prior-art electrical vehicles has been the need to recharge the batteries which provide the power for the electrical motor drive system.

The present invention overcomes this problem through the provision of an electrical energiser-motor system which produces more energy than is expended, thereby enabling the excess energy to be stored in the battery system, to be drawn upon as required. Thus, the need for recharging of the batteries associated with conventional electrical vehicles is eliminated with the system of this invention. It should be noted that while the system of the invention has enormous potential in connection with its use in electrical vehicles, the system is clearly not limited to such use and would obviously be advantageous when used, for example, as the energy source for a home energy plant, as well as in many other applications.

In accordance with the invention, and energy producing system of the type described above is provided which comprises and electrical "energiser" comprising at least one double-wound stator and at least one double-wound shaft-mounted rotor located within a housing, electrical energy being collected from the rotor through a suitable electrical take-off device and being available for utilisation by the system, and an electric motor, powered by the energiser for driving the rotor shaft of the energiser. A battery arrangement is initially used to supply energy to the system and, as stated above, the excess energy generated by the energiser over and above that required by the system and the system load, is stored through charging of the batteries. The motor includes an armature with a plurality of winding slots in it and a plurality of windings being wound into two circumferentially spaced slots in the armature, i.e. such a winding is wound through a first slot (e.g. slot 1) and returned through a second spaced slot (e.g. slot 5). depending on the energy demands, the energiser may include a pair of stators and rotors, with the rotors being mounted on a common shaft. The motor is preferably energised through an arrangement of a commutator and plural brushes, while a slip ring and associated brushes connected to an output bridge circuit form the energy take-off for the energiser.

Other features and advantages of the invention will be shown in the detailed description of the preferred embodiments which follows.

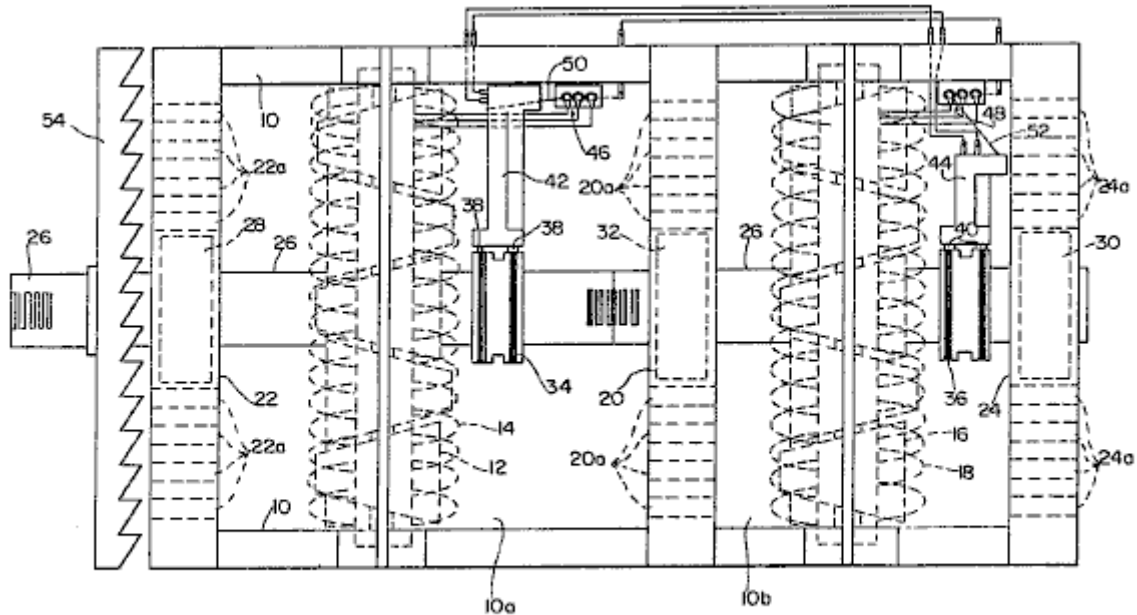

FIG. 1

Fig.1 is a partially sectioned elevational view of the electrical "energiser" of the invention.

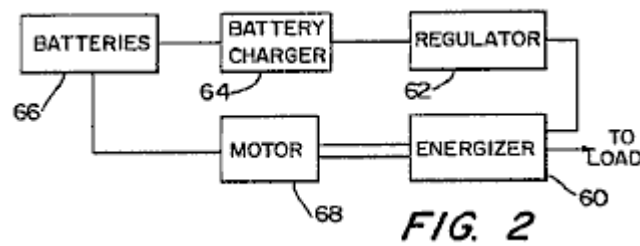

FIG. 2

Fig.2 is a block diagram of the overall energy-producing system of the invention

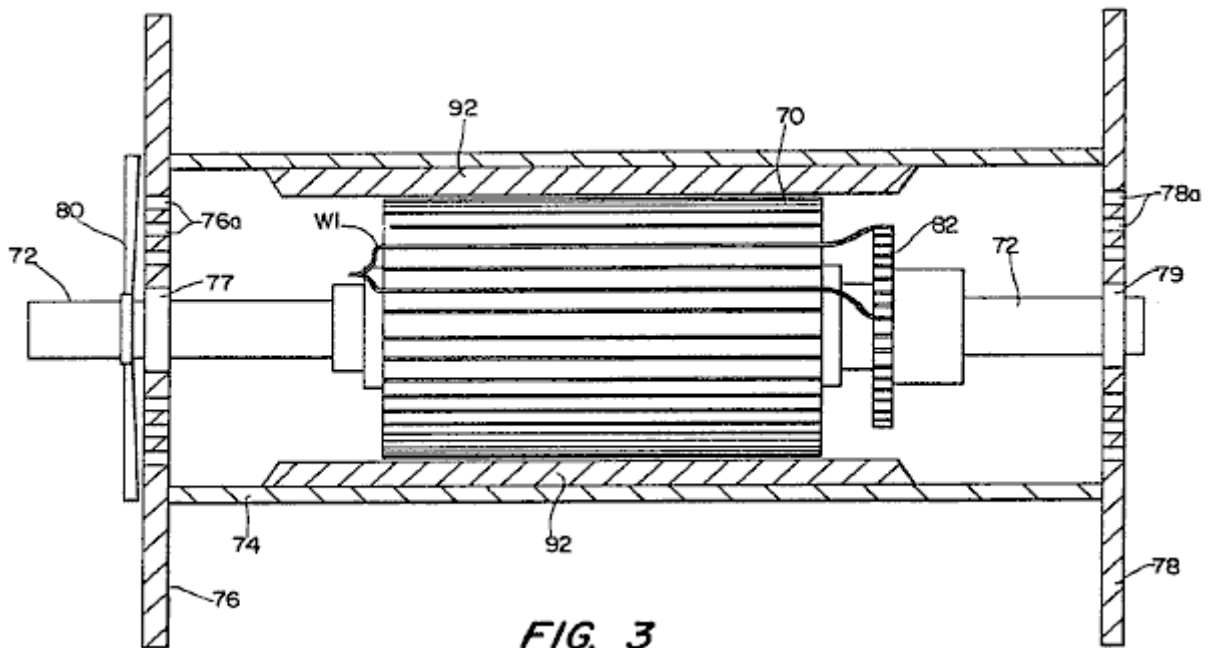

FIG. 3

Fig.3 is a partially sectioned side elevational view of a modified electrical motor constructed in accordance with the invention.

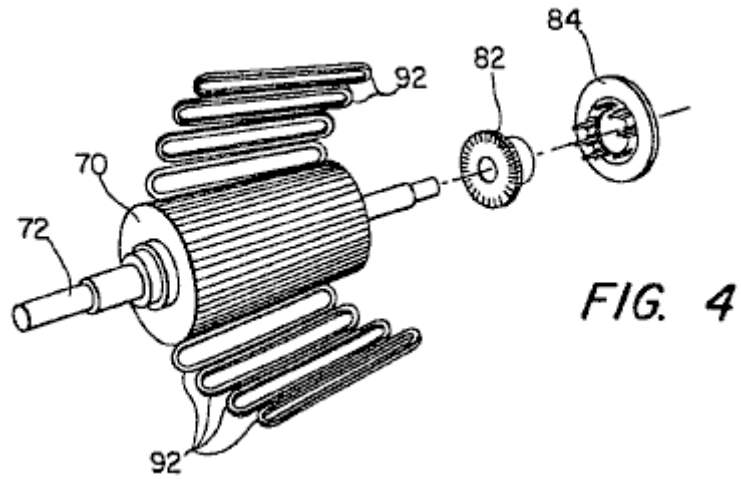

Fig.4 is an exploded perspective view of the basic components of the motor of Fig.3.

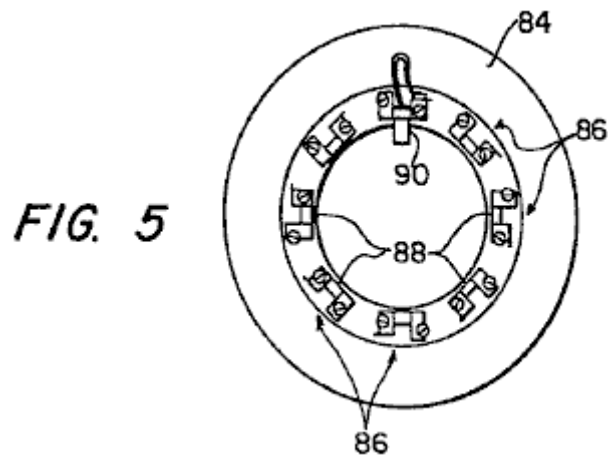

Fig.5 is an end view of the brush holder also illustrated in Fig.4.

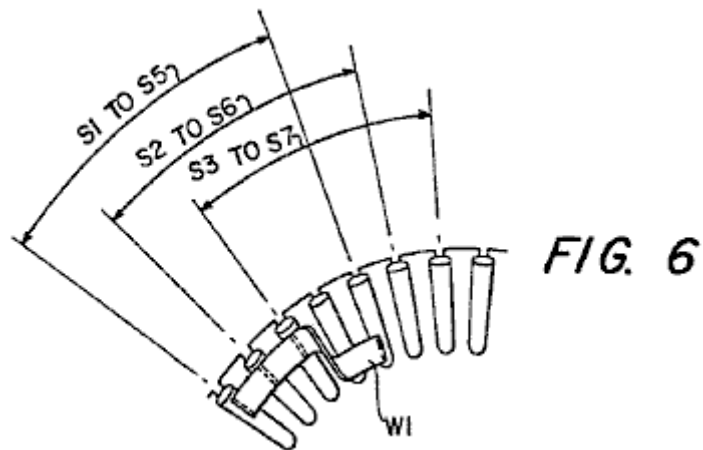

Fig.6 and Fig.7 show details of the winding pattern of the motor of Fig.3.

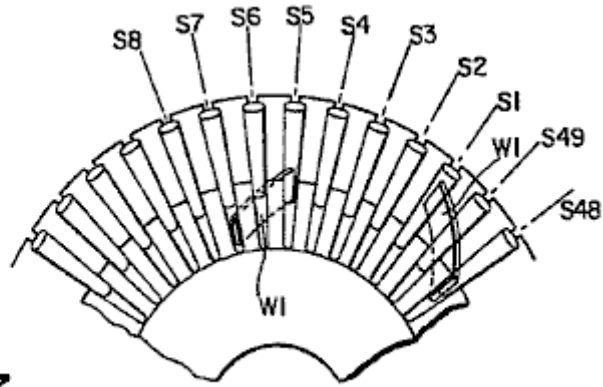

FIG. 7

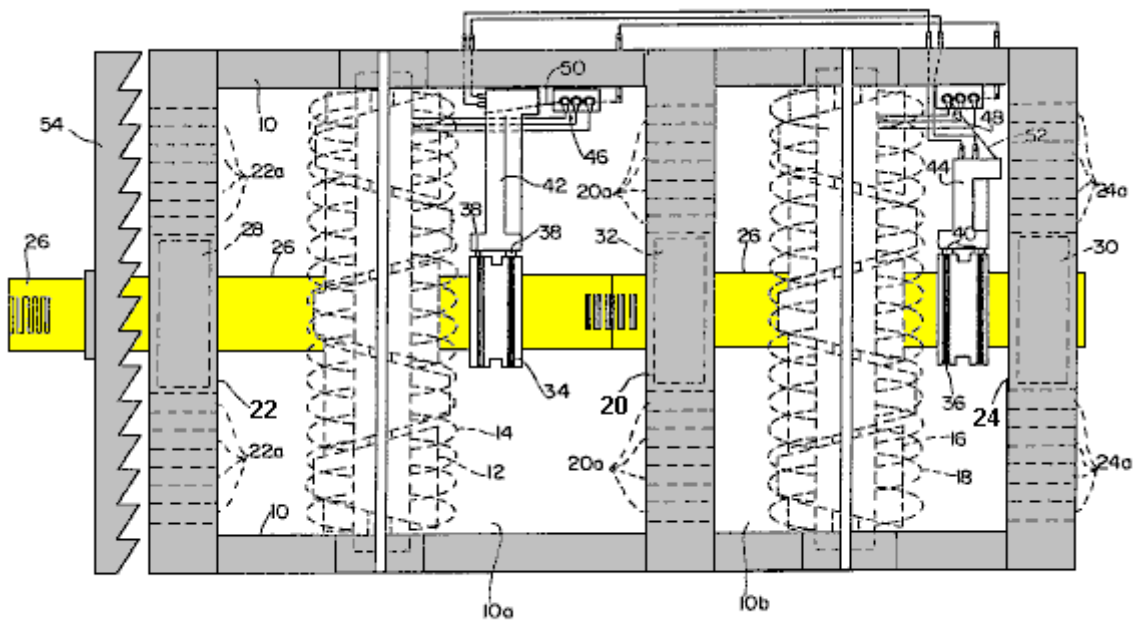

FIG. 1

Referring to **Fig.1**, a preferred embodiment of the “energiser” device of the invention is shown. The device includes a housing **10**, in which are located, in a first chamber or compartment **10a**, a first rotor **12** and a first stator **14** and, in a second compartment **10b**, a second rotor **16**, and a second stator **18**. It should be noted that although two stator-rotor combinations are used in this embodiment, a single stator-rotor combination can be used for some applications. Housing **10** is divided into the compartments **10a** and **10b**, by a centre plate **20** and it includes a pair of end plates **22** and **24**. Both the rotors **12**, **16** and the stators **14**, **18** are double wound and the rotors **12**, **16** are nested inside their respective stators **14** and **18** and mounted for rotation on a common shaft **26**. Shaft **26** extends longitudinally through housing **10** and is mounted on bearings **28** and **30**, supported by end plates **22** and **24**, and a further bearing **32** which is supported by central plate **20**.

A pair of slip rings **34** and **36**, are mounted on shaft **26** and connect with their corresponding brush pairs **38** and **40**.

Slip rings **34** and **36** are connected to rotors **12** and **16** respectively, and permit the current flowing in the rotor windings to be collected through the associated pairs of brushes **38** and **40**. Brush pairs **38** and **40** are mounted on respective brush holders **42** and **44**. The terminals of respective bridge circuits **46** and **48** are connected to stators **14** and **18**, while conversion bars **50** and **52** are connected to brush holders **42** and **44**, as indicated.

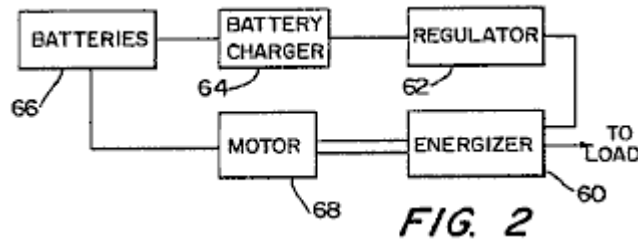

FIG. 2

A cooling fan **54**, is also mounted on shaft **26** and a plurality of apertures **201**, **22a** and **24a** are provided in centre plate **20** and end plates **22** and **24**, to promote cooling of the device. The energiser of **Fig.1** is preferably incorporated in a system such as shown in a highly schematic manner in **Fig.2** where the output of the energiser is used to supply the energy for driving a motor. To this end, the energiser, which is denoted by **60** in **Fig.2**, is connected through a regulator **62**, to battery charger **64** for batteries **66** connected to a motor **68**. These batteries **66** are used to provide the initial energisation of the system as well as to store energy produced by the energiser **60**. It will be understood that the energiser **60** provides energy enough to power motor **68** (which, in turn, drives energiser **60** through rotation of shaft **26**) as well as to provide storage for energy in the system. It will also be appreciated that the system illustrated schematically in **Fig.2** includes suitable controls (switches, rheostats, sensors, etc.) to provide initial energisation as well as appropriate operational control of the system.

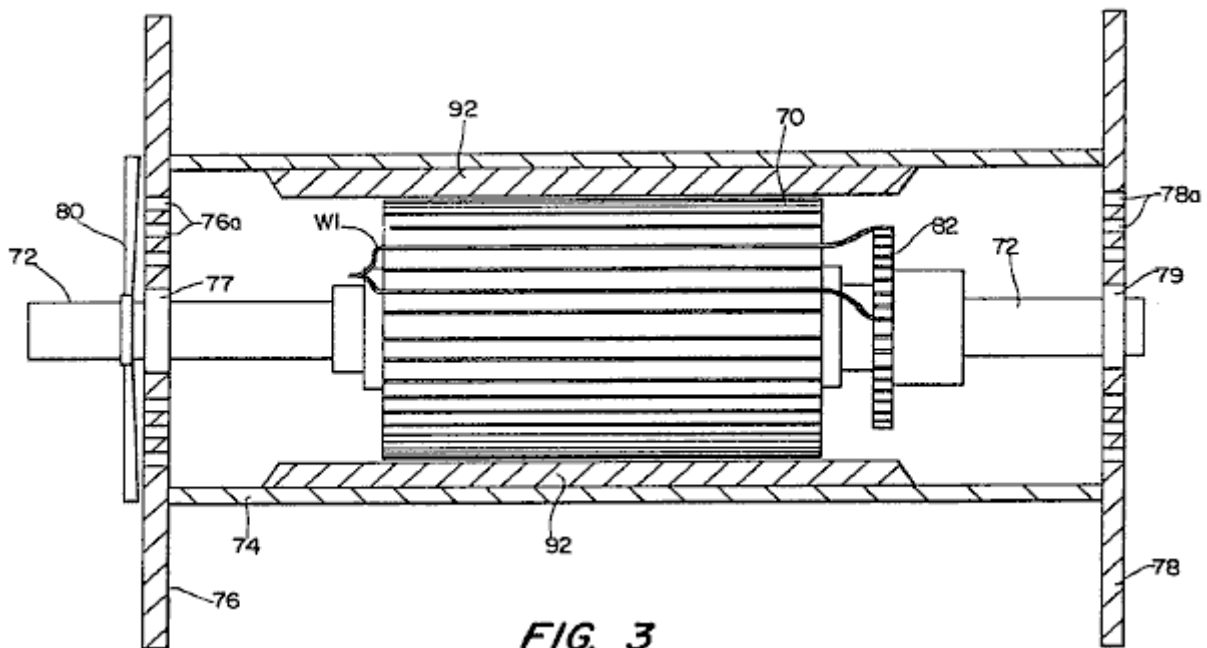

FIG. 3

In a preferred embodiment, motor **68** is of the form shown in **Fig.3**. As illustrated, the motor is of a generally conventional form (with exceptions noted below) and comprises an armature **70**, mounted on a shaft **72** within housing **74**. Housing **74** includes a pair of end plates **76** and **78**, which mount shaft bearings **77** and **79**. Apertures **76a** and **78a** are provided in end plates **76** and **78** and a cooling fan **80** is mounted on shaft **72** to provide cooling.

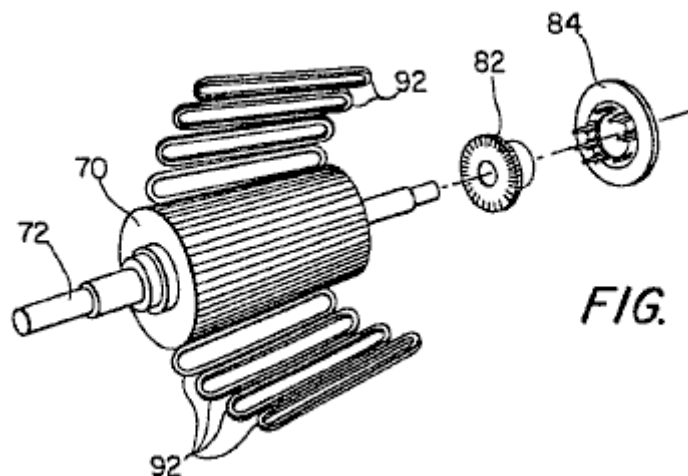
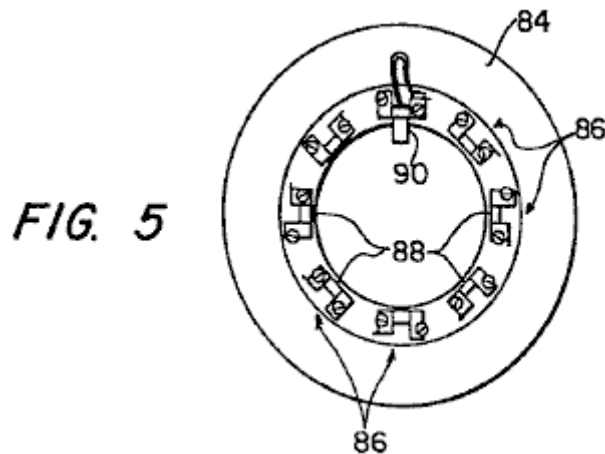

FIG. 4

A commutator **82** is also mounted on shaft **72**, and co-operates with associated brushes (not shown in **Fig.1**), to conduct current to the windings of armature **70**. This co-operation is shown best in **Fig.4** which is an exploded view, illustrating the armature **70**, commutator **82** and a brush holder **84**.



As shown in **Fig.5**, the brush holder **84** includes eight brush mounts **86**, each of which defines a slot **88** in which a pair of brushes is mounted. One brush **90** is shown in **Fig.5**, it being understood that two such brushes are mounted in each slot **88** so that sixteen brushes are required.

The motor of **Fig.3** to **Fig.6** includes eight pole shoes (not shown) which are secured to housing **74** and which serve to mount eight field coils or windings **92** (see **Fig.3** and **Fig.4**) spaced out around the periphery of armature **72**.

An important feature of the motor of **Fig.3** to **Fig.6** concerns the manner in which the windings for armature **70** are wound. As illustrated in **Fig.3**, **Fig.6** and **Fig.7**, a typical winding **W1** is wound in two slots, with the illustrated winding being doubled back and continuing from armature slot **S1** to armature slot **S5** (see **Fig.3** and **Fig.6**). Similarly, the winding in slot **S2** continues to slot **S6**, the winding of slot **S3** continues to slot **S7**, and so on for the forty-nine windings.

In a specific preferred embodiment, the motor described above is a 48-volt, 412 horsepower motor having a top operating speed of 7,000 rpm. A rheostat control (not shown) is used to control the input voltage and, as discussed above, the motor is powered from the energiser of **Fig.1**. It will be appreciated that the energy take-off from the system is preferably from the output shaft of the motor, although the electrical energy may also be tapped off from the energiser output.

Although the invention has been described in relation to exemplary embodiments, it will be understood by those skilled in the art, that variations and modifications can be effected in these embodiments without departing from the scope and spirit of the invention.

CLAIMS

1. An energy-producing system providing an output for utilisation by a utilising device, the system comprising:

An electrical energising means comprising a housing (**10**); at least one double-wound stator (**14** or **18**) located within the housing; at least one double-wound rotor (**12** or **16**) located within the housing; a rotor shaft (**26**), supported in the housing, and on which the double-wound rotor is mounted; and an energy take-off mechanism (**34** or **36**) including a mechanism for collecting electrical energy from the rotor, mounted on the shaft and connected to the rotor, the mechanism having at least one stationary output.

A motor (**68**), including a connection to the electrical energiser through which to draw the power to operate the motor and drive the rotor shaft of the energiser, the motor having an armature (**70**) with a plurality of winding slots (**S1** to **S49**) in it, and a plurality of windings (**W1**) wound in those slots, at least some of the windings being wound in two slots spaced out around the circumference of the armature (for example, **S1** and **S5**), and an energy supply mechanism (**66**) for supplying electrical energy to the motor at least during initial energisation of the motor, and connected to the energiser for supplying energy to the motor during its operation.

2. A system as in Claim 1, where the energiser includes a pair of these rotors (**12, 16**) and a pair of stators (**14, 18**), the rotors being mounted on a common shaft (**26**).
3. A system as in Claim 1, where the energy take-off includes a slip ring (**34** or **36**) and at least one brush (**38** or **40**) for collecting electrical current from the rotor windings, the brush being connected to a bridge circuit (**46** or **48**).
4. A system as in Claim 1, where the motor contains a commutator (**82**) through which energy is supplied to the armature windings.
5. A system as in Claim 4, where the same winding (W1) is wound in the first and fifth slot positions of the motor armature, and the ends of that winding are connected to two positions spaced out around the circumference of the commutator (see **Fig.3**).

MOTIVE POWER-GENERATING DEVICE

Please note that this is a re-worded excerpt from this patent. It describes a motor which has an output power greater than its input power.

SUMMARY OF THE INVENTION

It is an object of the invention to provide a motive power generation device in which the occurrence of a force acting in a direction opposite to the direction of movement of a rotor and/or a stator is prevented, so as to permit efficient use of electric energy to be applied to electromagnets, as well as magnetic energy generated by a permanent magnet.

In order to achieve the above object, the first invention comprises a permanent magnet disposed around a rotational output shaft which is mounted on a bearing, a magnetic body positioned concentrically with the permanent magnet for rotation with the output shaft, the magnetic body being subjected to the magnetic flux of the permanent magnet, a plurality of electromagnets permanently mounted on the support member so that they are spaced a predetermined distance around the periphery of the magnetic material, each magnetic circuit of the electromagnets being independent of one another and the excitation change-over mechanism of the electromagnets which can sequentially magnetise one of the electromagnets which is positioned forward, with regard to a rotational direction, of the output shaft, so as to impart to the electromagnet a magnetic polarity magnetically opposite to that of the magnetic pole of the permanent magnet, whereby a magnetic flux passing through the magnetic body converges in one direction thereby applying a rotational torque to the output shaft.

According to the first invention, when one of the electromagnets which is positioned ahead in the rotational direction of the rotational output shaft, a magnetic field created by the excited electromagnet and a magnetic field created by the permanent magnet interact with each other. Thus, the magnetic flux passing through the magnetic body converges toward the excited electromagnet, so as to rotate the rotational output shaft by a predetermined angle toward the excited electromagnet. When the rotational output shaft has been rotated by the predetermined angle, the above excited electromagnet is de-magnetised, and another electromagnet currently positioned ahead with respect to the rotational direction of the rotor output shaft is excited or magnetised. Sequential excitation of the electromagnets in the above manner permits rotation of the output shaft in a predetermined direction. In this regard, it should be noted that the electromagnets are excited so as to have a magnetic polarity opposite to that of the magnetic pole of the permanent magnet and that the magnetic circuit of the excited electromagnets is independent from those of adjacent electromagnets. Thus, the magnetic flux generated by the excited electromagnet is prevented from passing through magnetic circuits of adjacent electromagnets, which, if it occurs, might cause the electromagnets to be magnetised to have the same polarity as that of the magnetic pole of the permanent magnet. Accordingly, no objectionable force will be generated which might interfere with rotation of the output shaft.

In order to achieve the above object, the second invention comprises a permanent magnet mounted on a movable body arranged movably along a linear track, a magnetic body mounted on the permanent magnet, the magnetic body being subjected to a magnetic flux of the permanent magnet, a plurality of electromagnets spaced an appropriate distance along the linear track, the electromagnets having magnetic circuits which are independent of one another and the excitation mechanism arranged to magnetise each of the electromagnets sequentially when each is positioned forward of the movable body, (with respect to the direction of movement) so as to impart to the excited electromagnet a magnetic polarity opposite to that of the magnetic pole of the permanent magnet, whereby a magnetic flux passing through the magnetic body converges in a predetermined direction so as to cause linear movement of the movable body.

According to the second invention, when the electromagnet positioned ahead of the forward end of the movable body with regard to the direction of the movement of the movable body is excited, a magnetic field generated by the excited electromagnet and magnetic field generated by the permanent magnet interact with each other. Thus, a magnetic flux passing through the magnetic body converges toward the excited electromagnet, so as to displace the movable body a predetermined distance toward the excited electromagnet. When the movable body has been moved the predetermined distance, the movable body is positioned below the above excited electromagnet, and another electromagnet is positioned ahead of the forward end of the movable body. When this occurs, excitation of the electromagnet positioned above the movable body is interrupted, and excitation of the electromagnet now positioned ahead of the forward end of the movable body is initiated. Sequential excitation of

the electromagnets in the above manner permits movement of the movable body in a predetermined direction. It should be noted that no objectionable force which would interfere with movement of the movable body is created for the same reason as that explained in relation to the first invention.

BRIEF DESCRIPTION OF THE DRAWINGS

Fig.1 is a front elevational view, partly in section and partly omitted, of a motor according to a first embodiment of the invention;

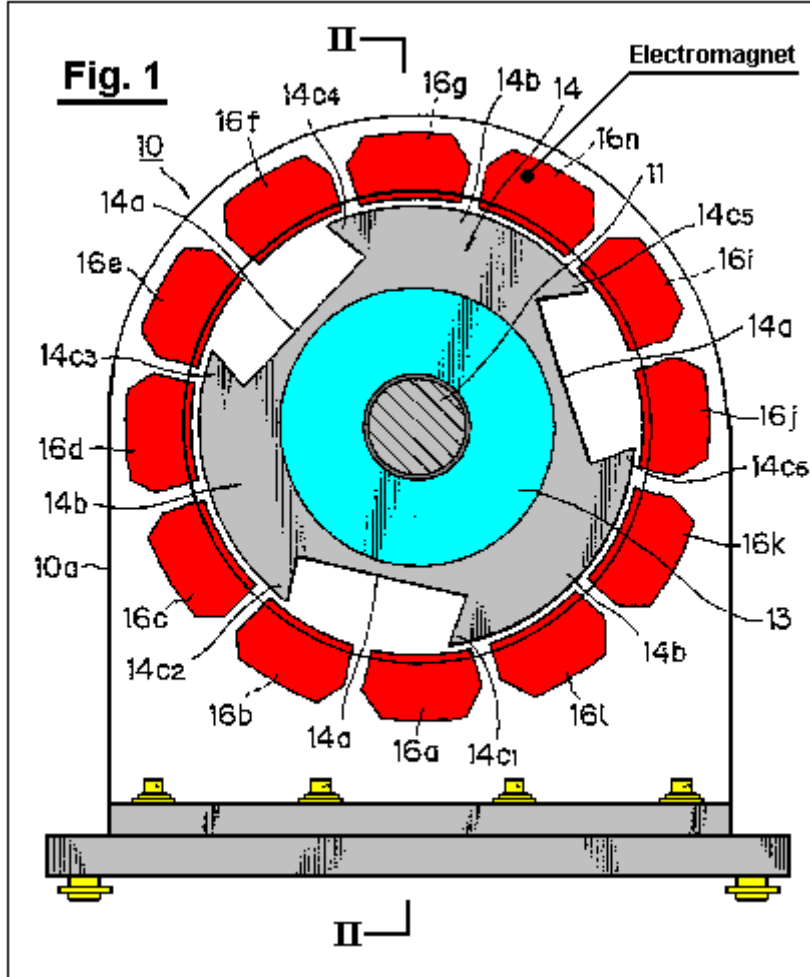

Fig.2 is a sectional view along line II--II in Fig.1;

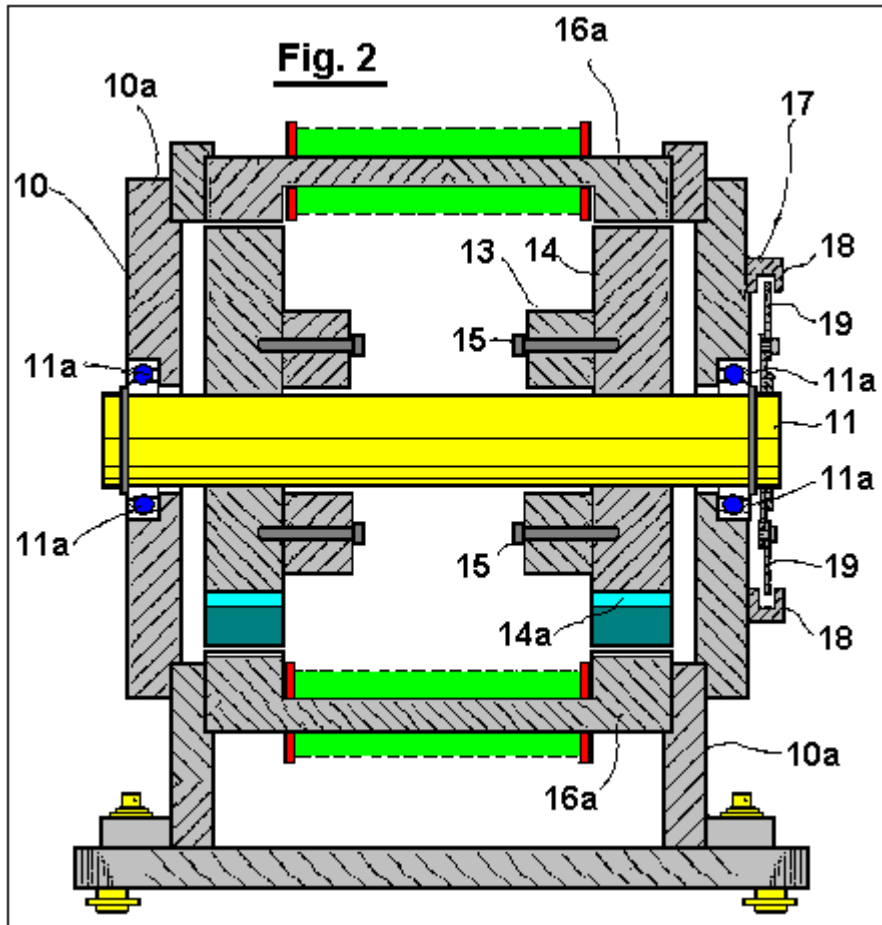

FIG. 3 is a rear elevational view of the motor provided with a light shield plate thereon;

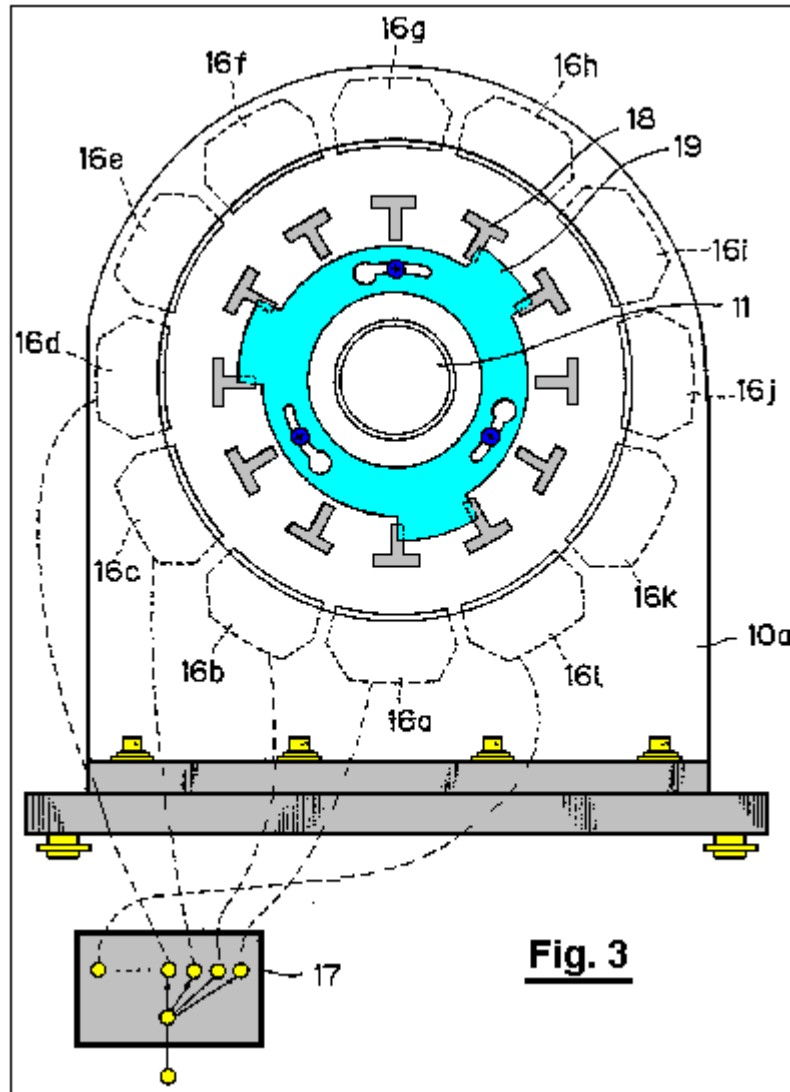
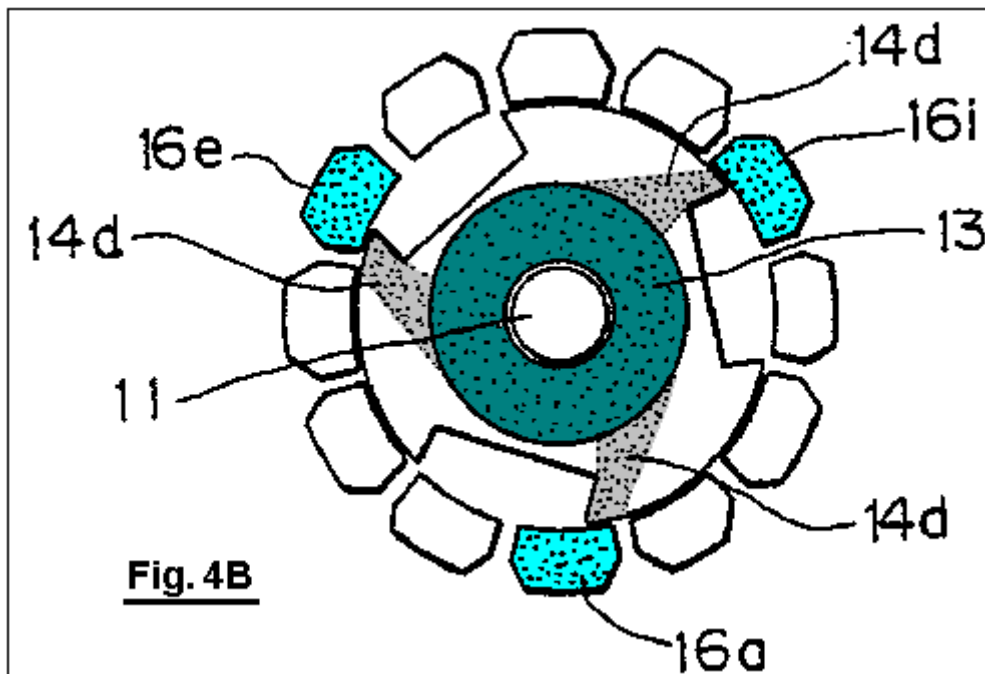
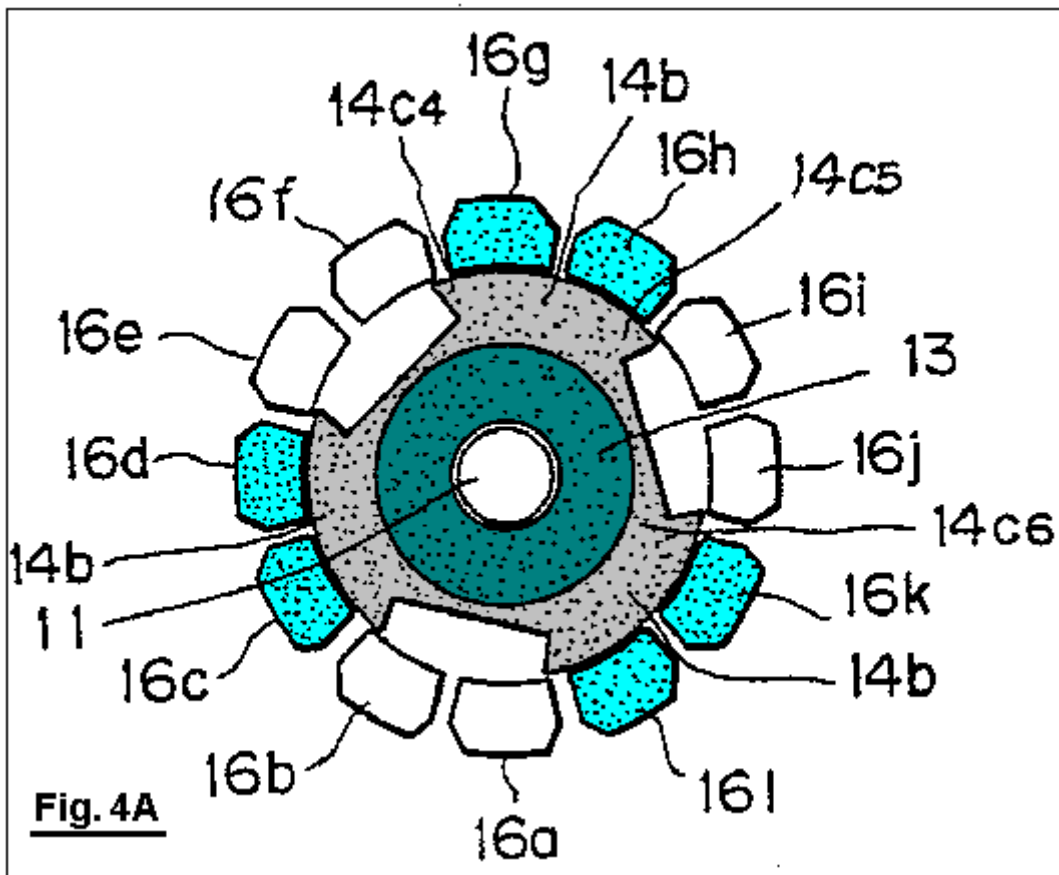
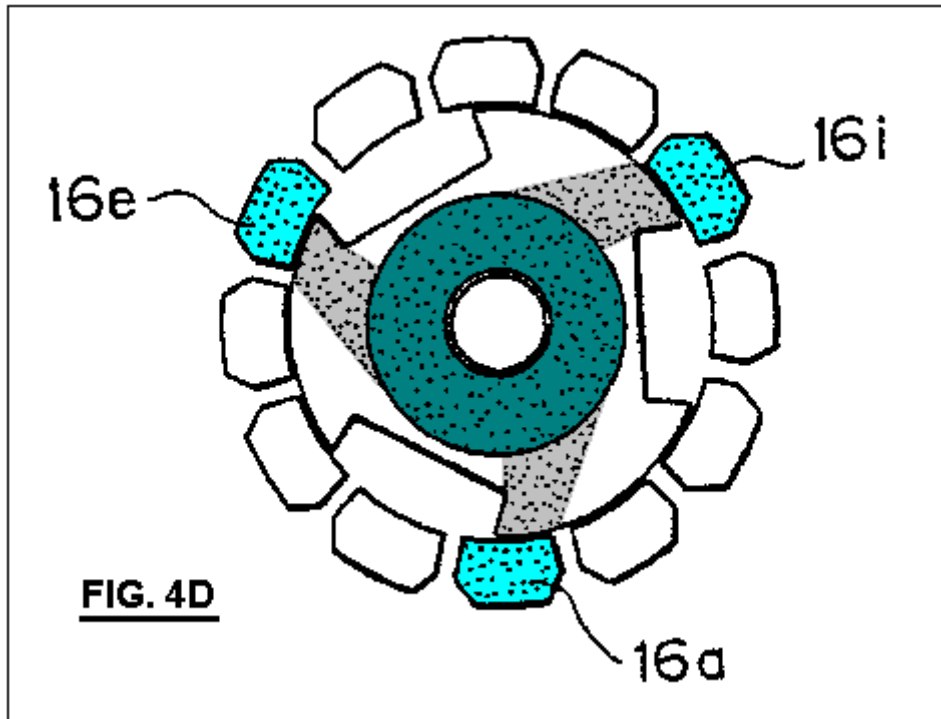
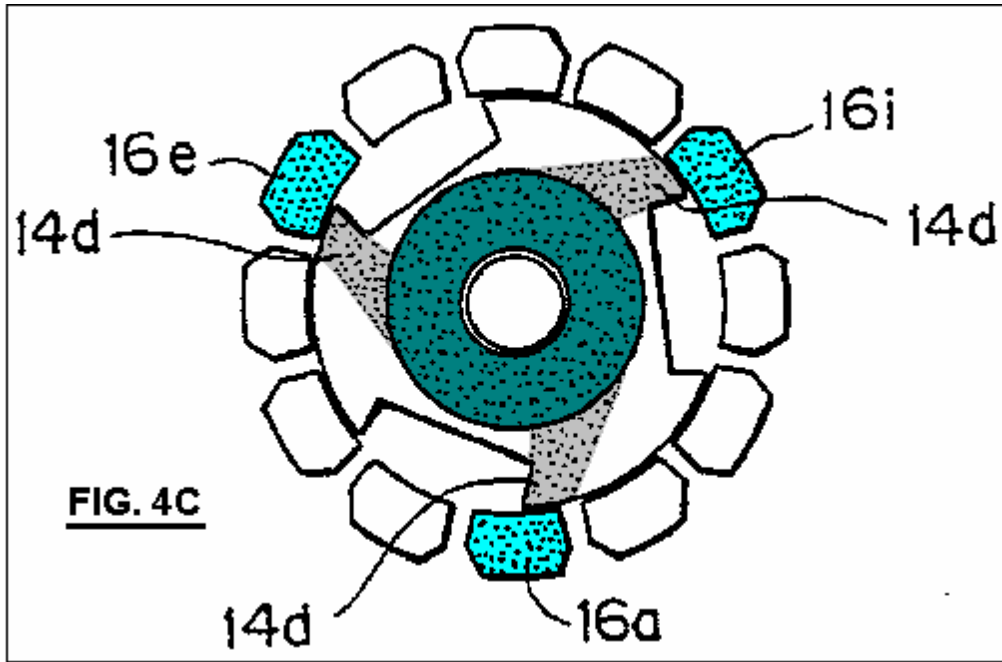
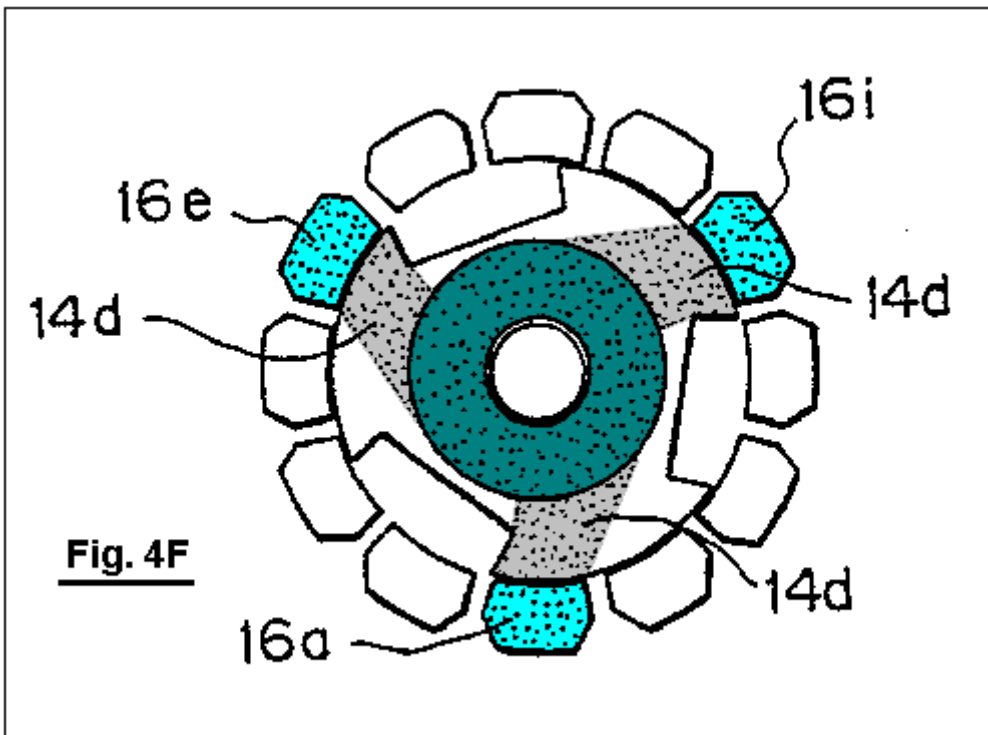
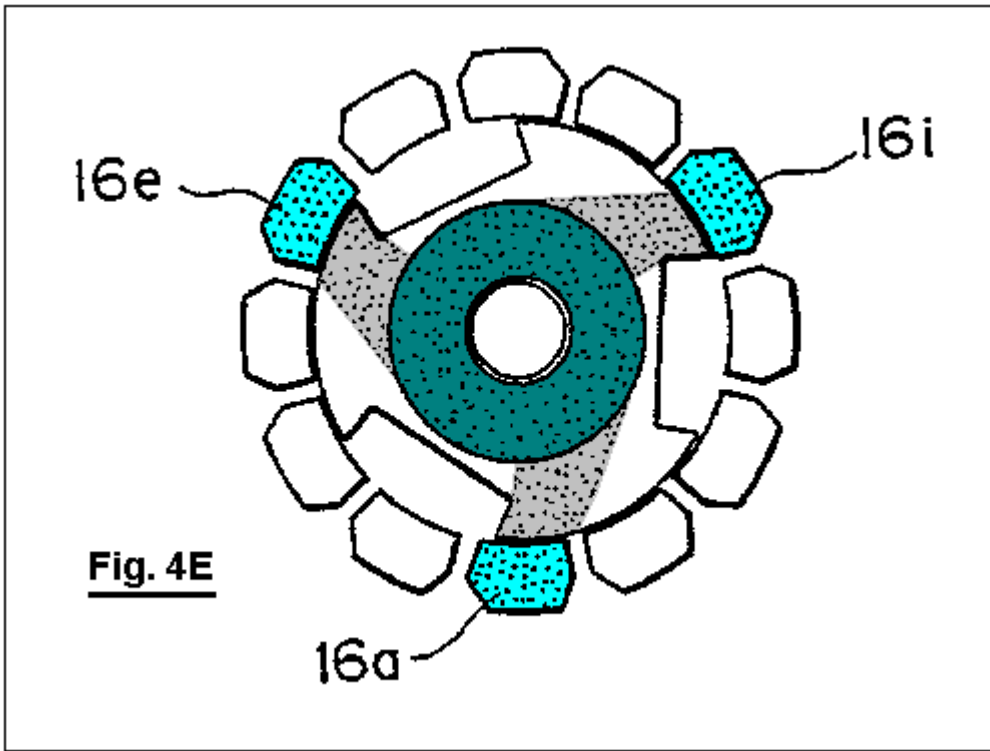

Fig.4A through Fig.4H illustrate operation of the motor when the electromagnets are excited or magnetised;







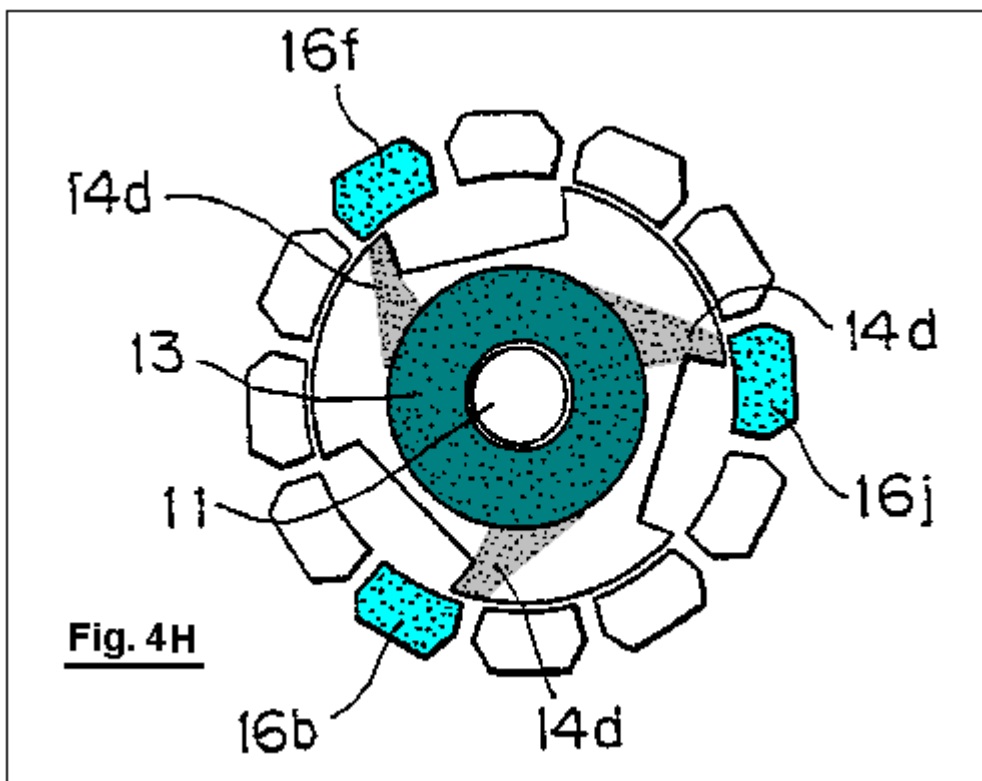
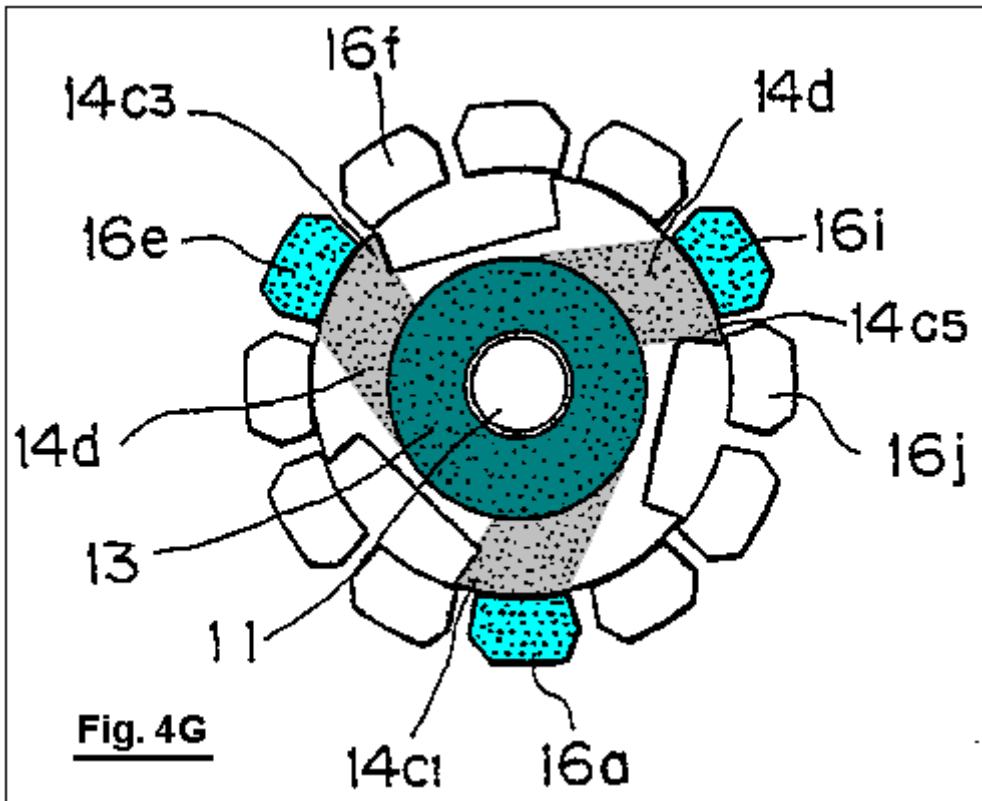

Fig.5A is an illustrative view showing a magnetic path of magnetic flux created by a permanent magnet of the motor when the electromagnets are not magnetised;

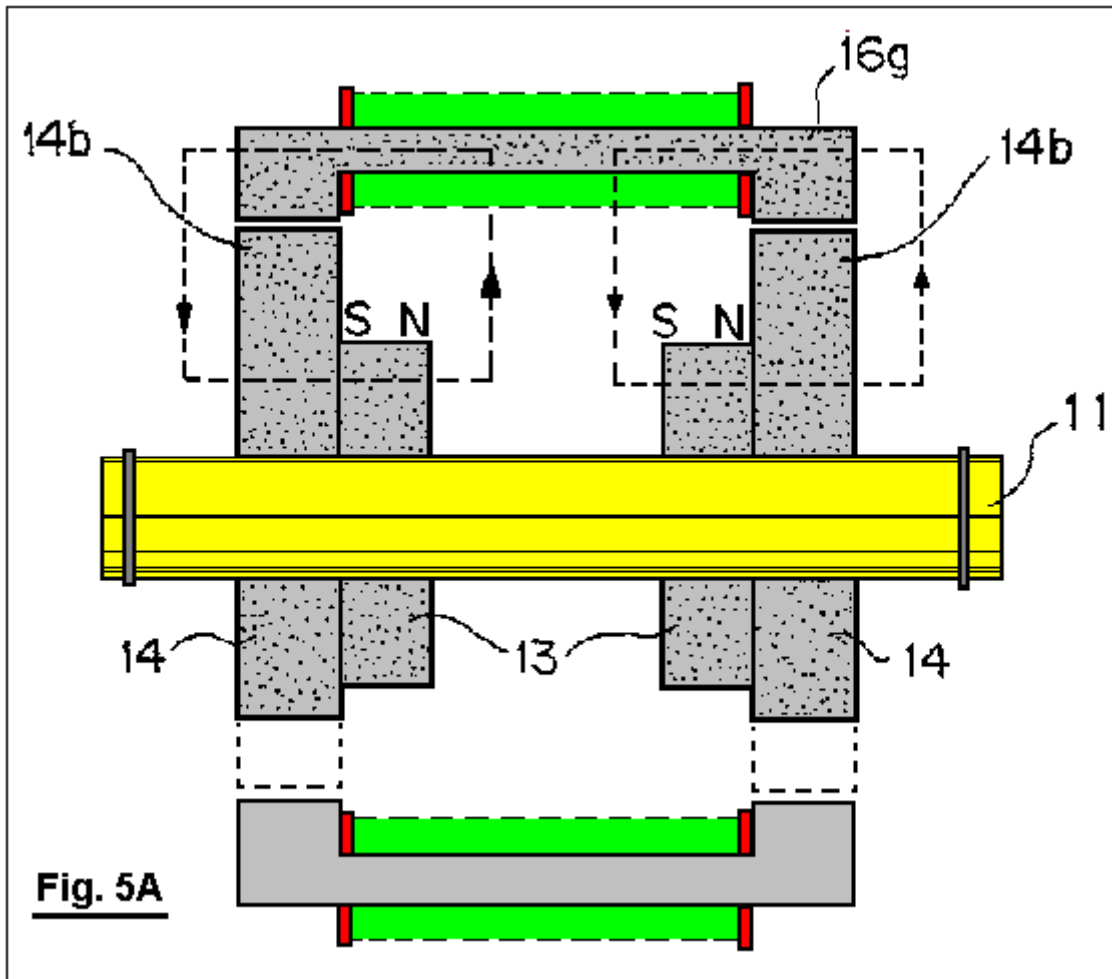
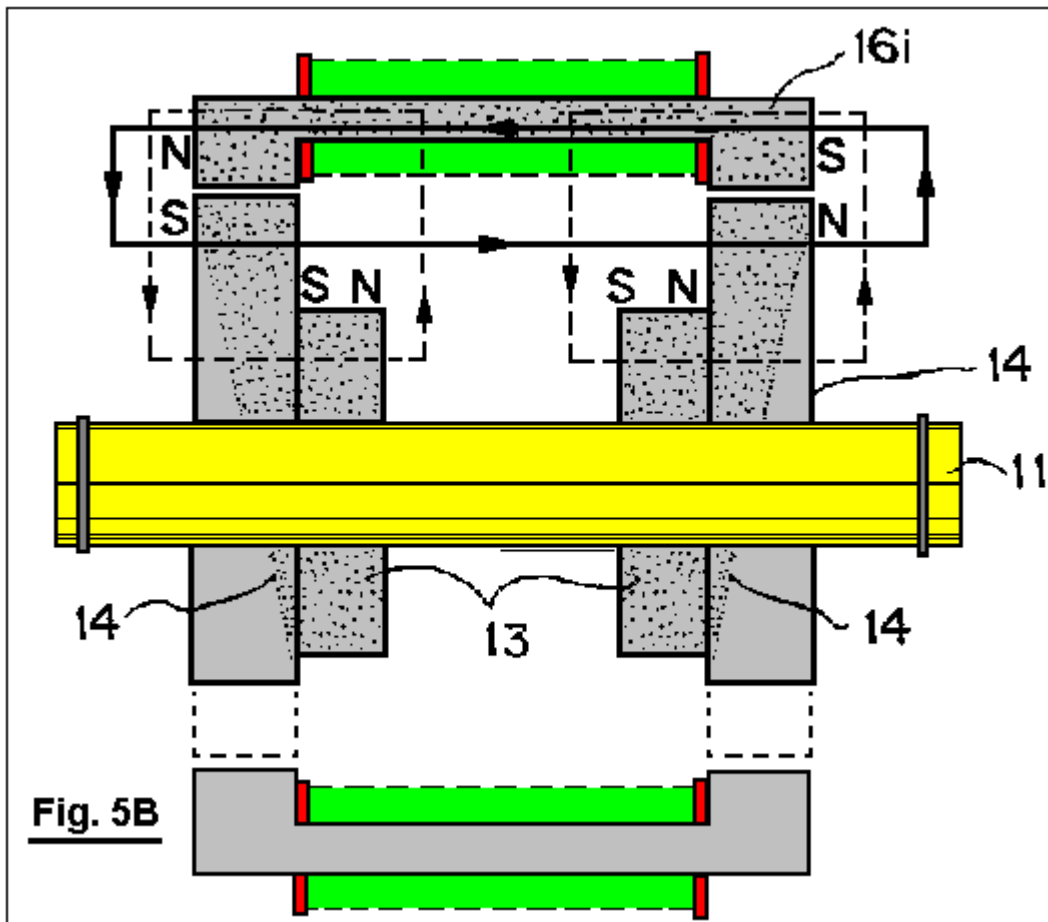

Fig.5B is an illustrative view showing a magnetic path of magnetic flux created by the permanent magnet of the motor, as well as magnetic path of magnetic flux created by the electromagnets;



FIGS. 6 through 9 are cross-sectional view illustrating a modified form the motor;

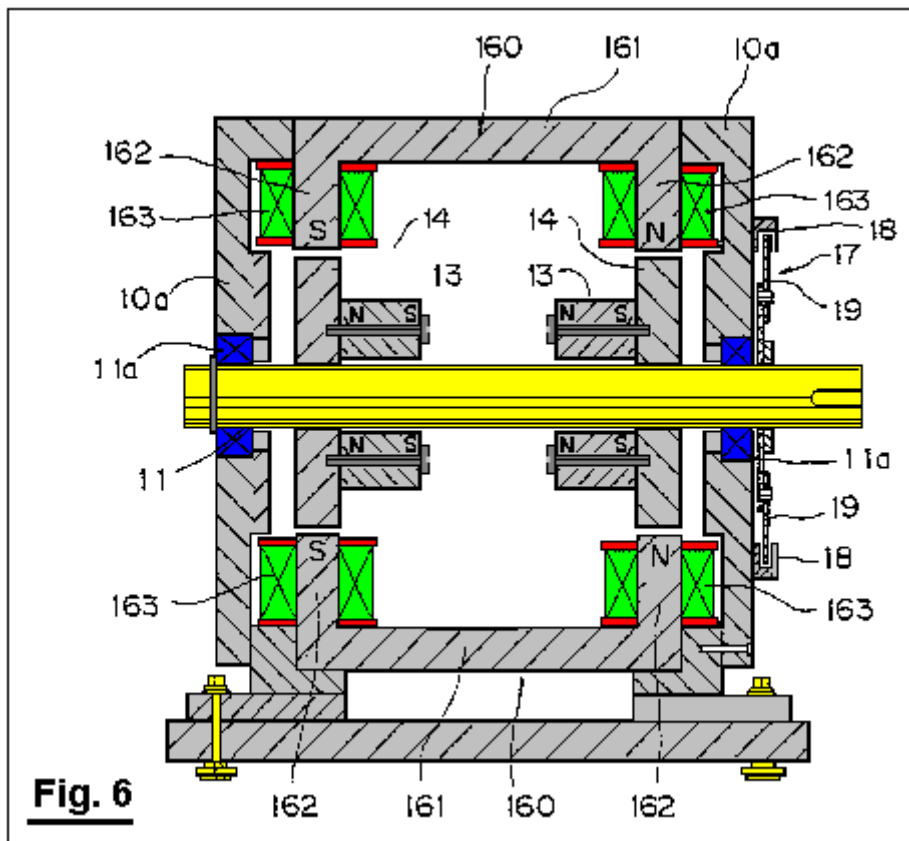

Fig. 6

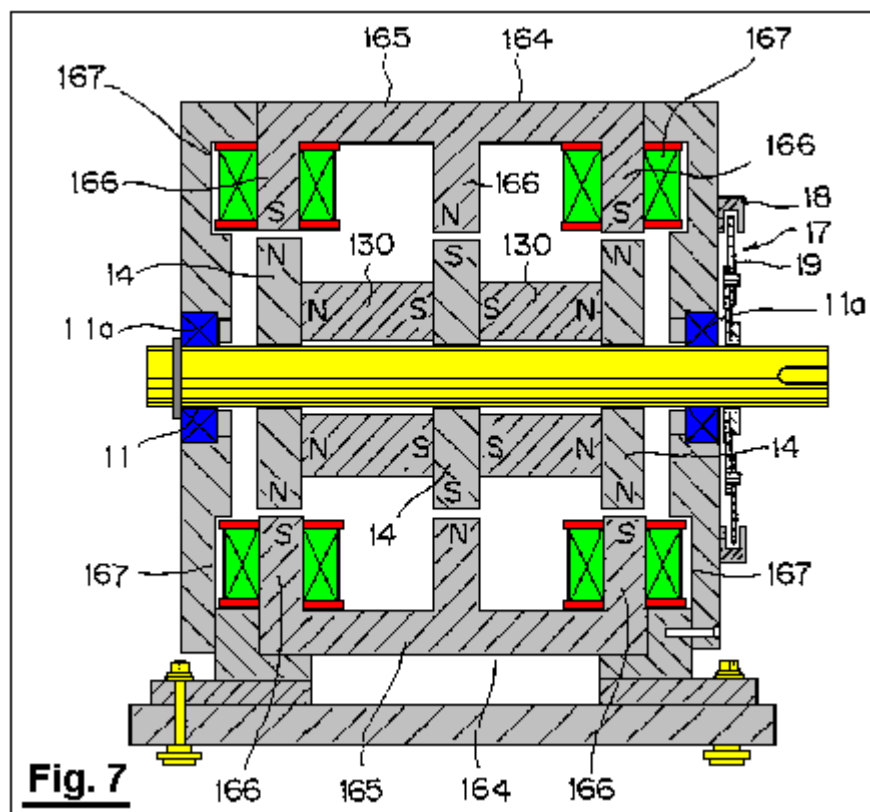
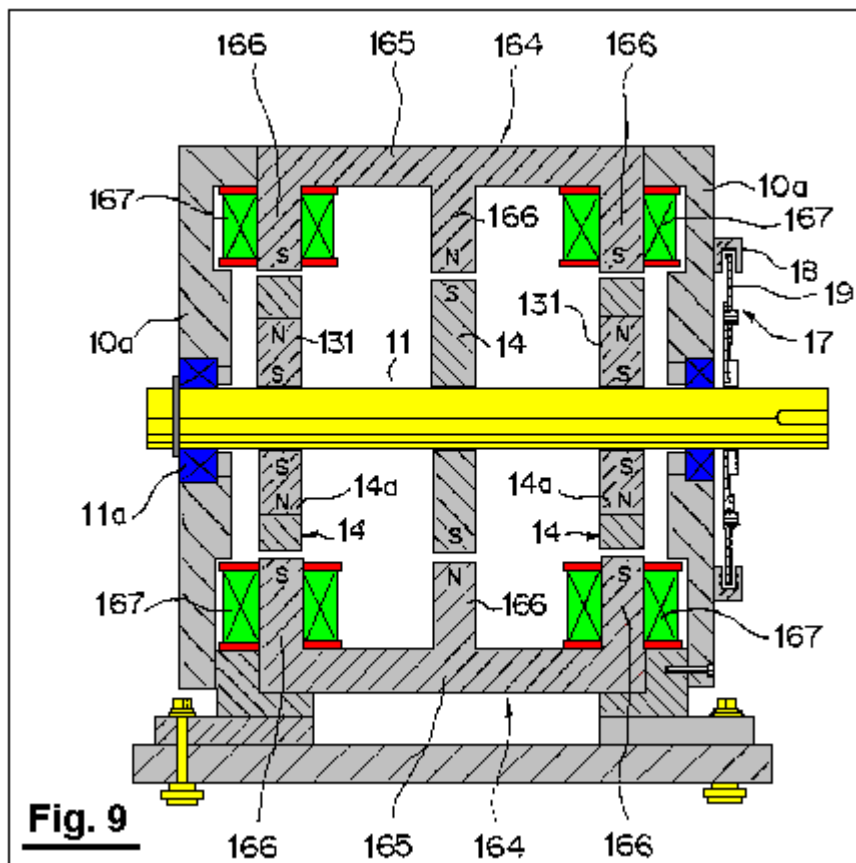
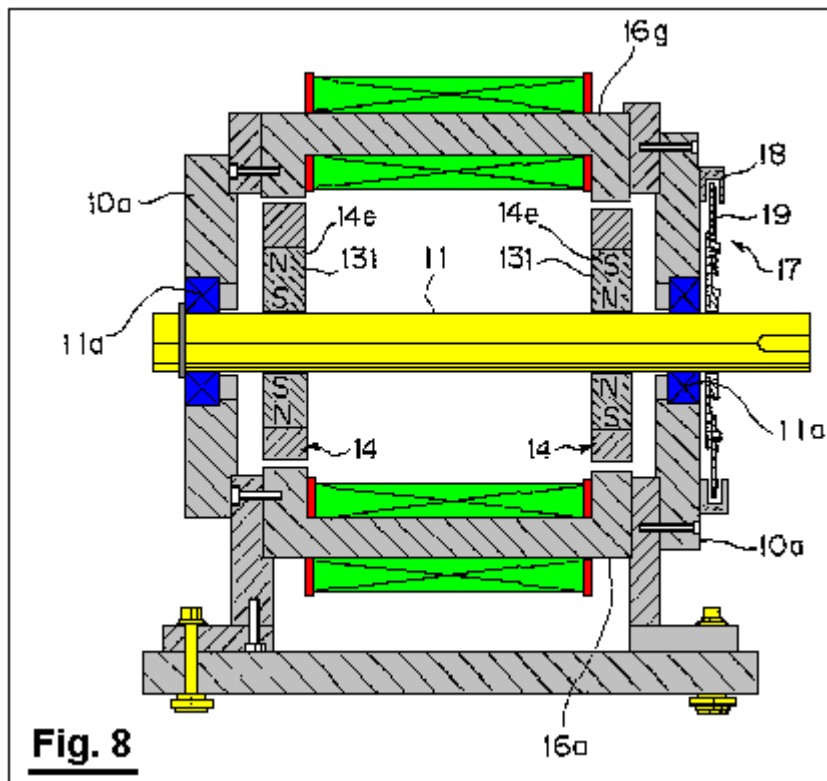
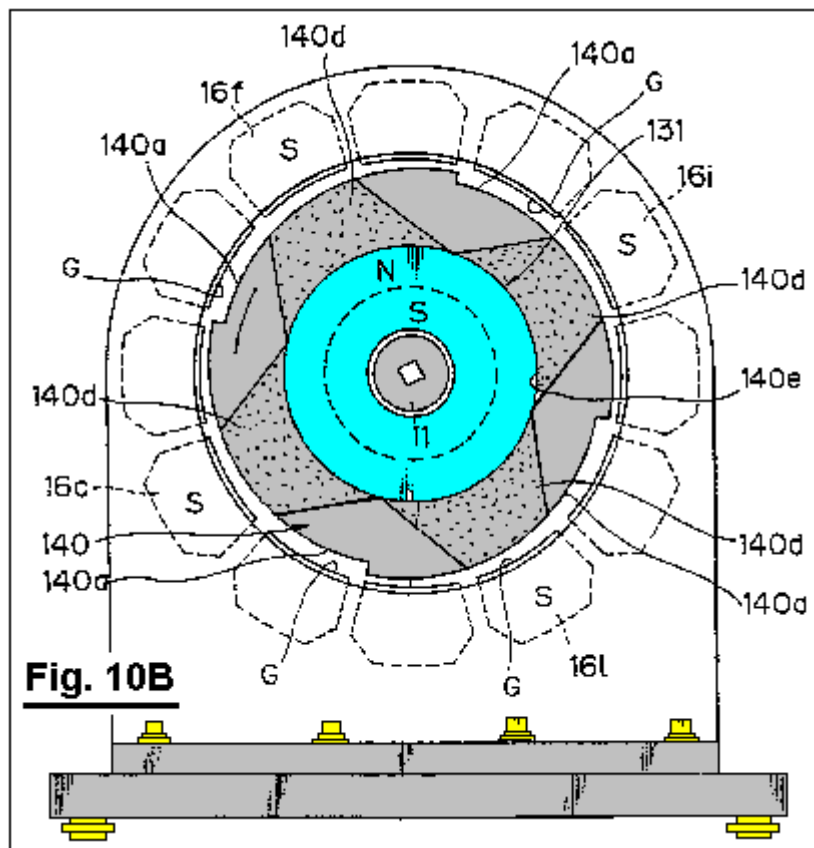
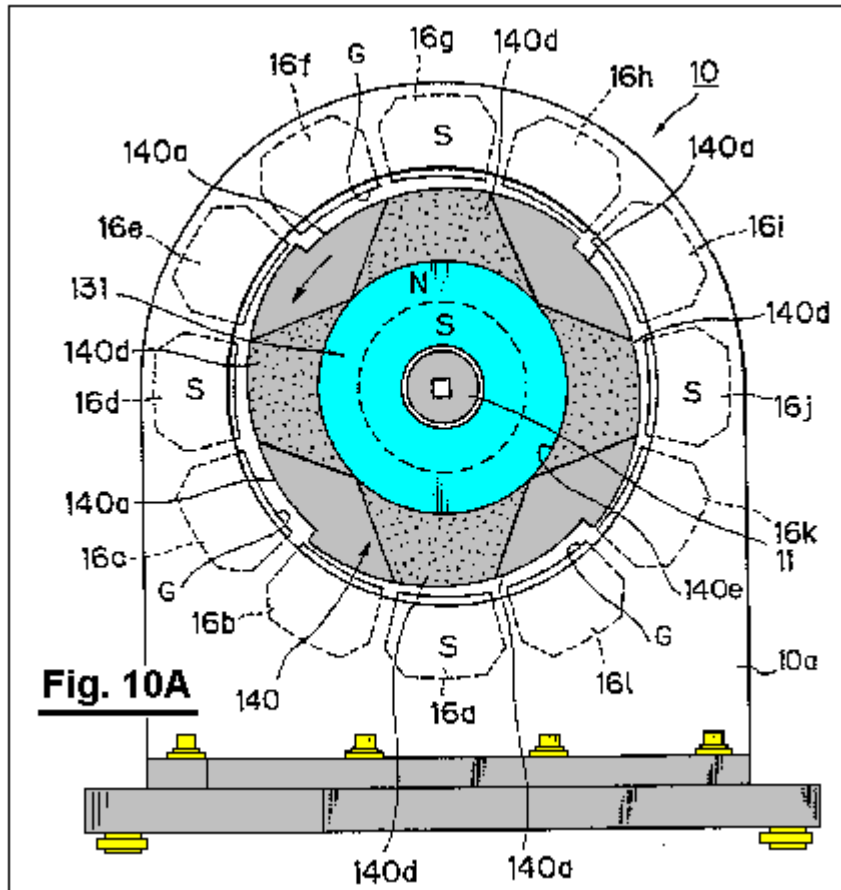
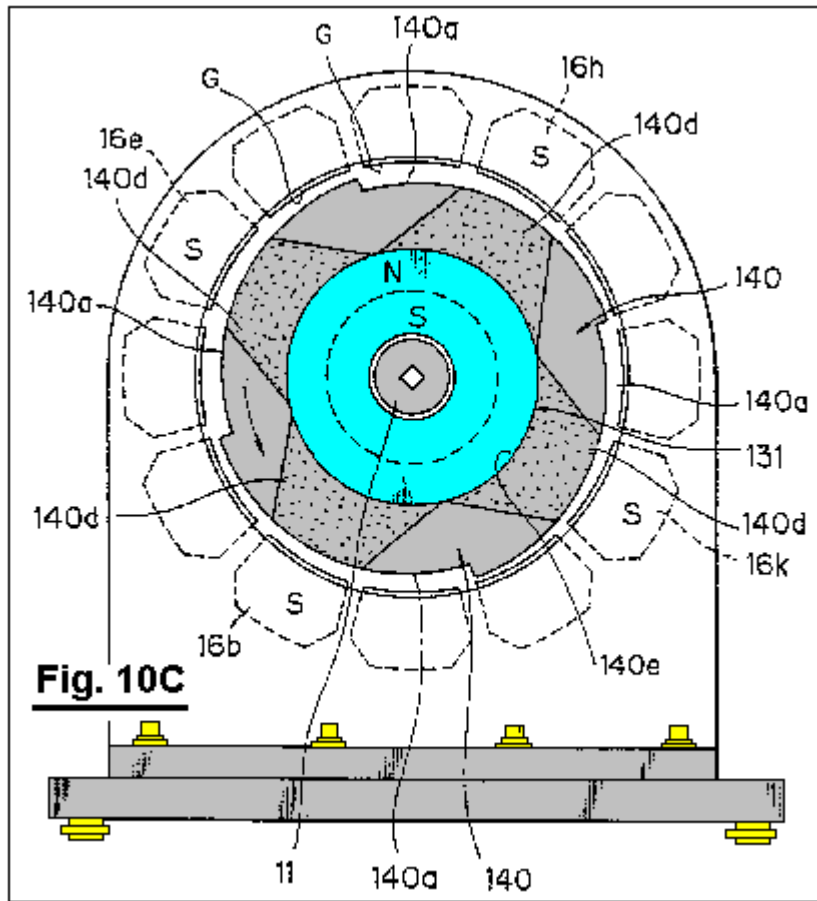

Fig. 7



FIGS. 10A through 10C are cross-sectional views illustrating operation of the modified motor;





FIGS. 11A through 11H are illustrative diagrams showing operation of a motor in a form of a linear motor according to a second embodiment of the invention;

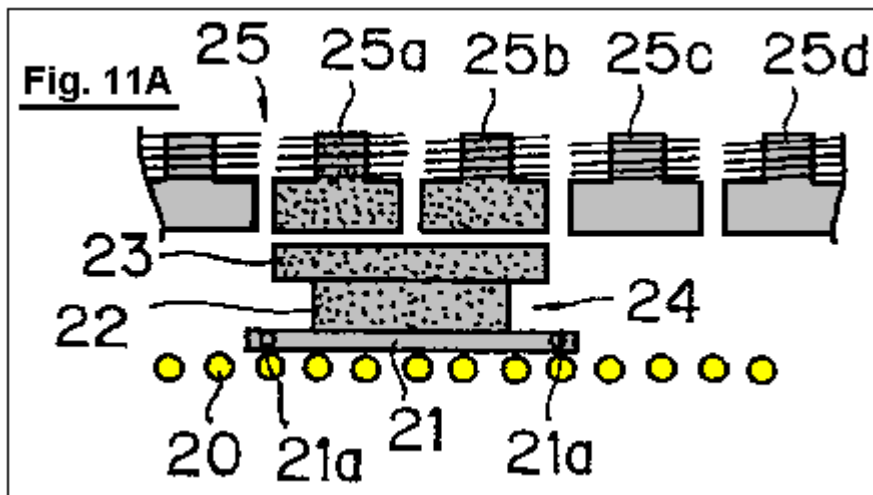

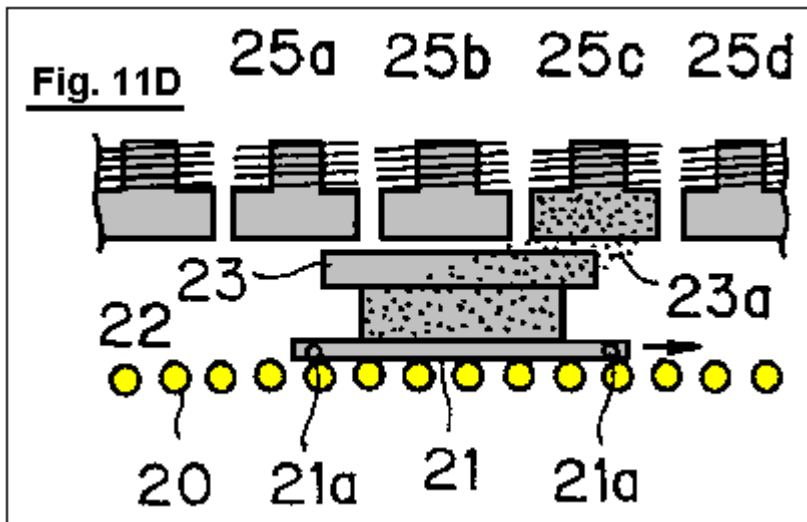
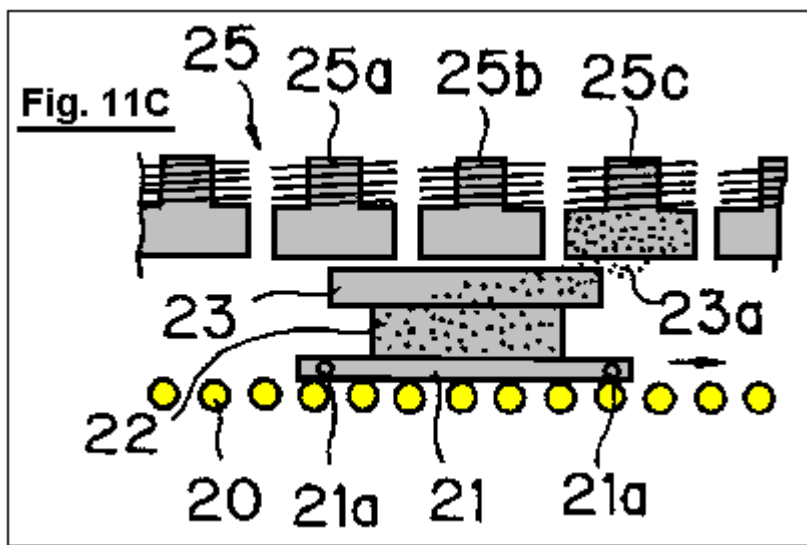
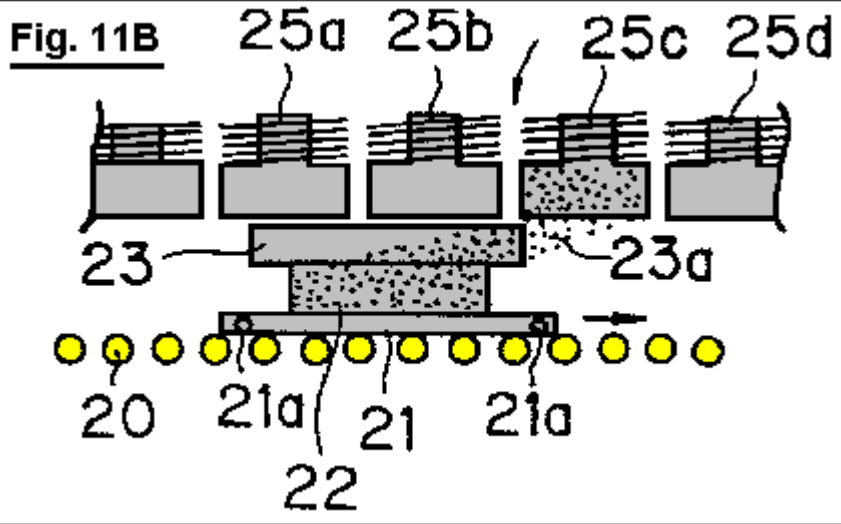

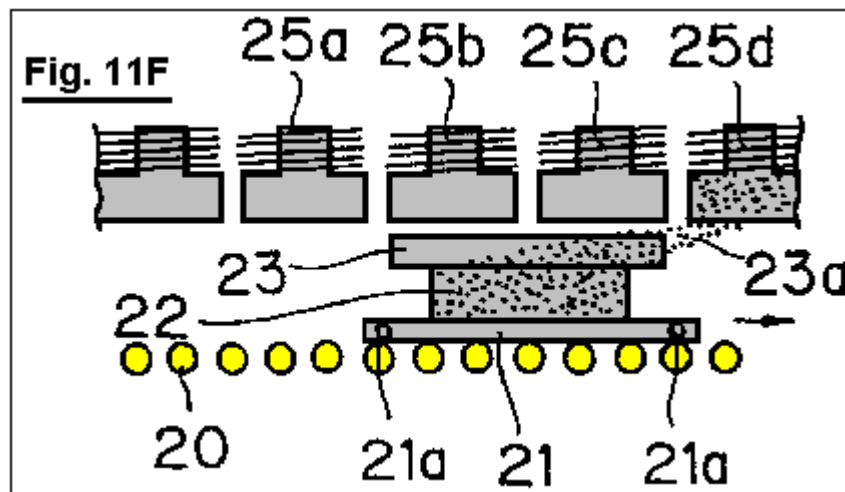
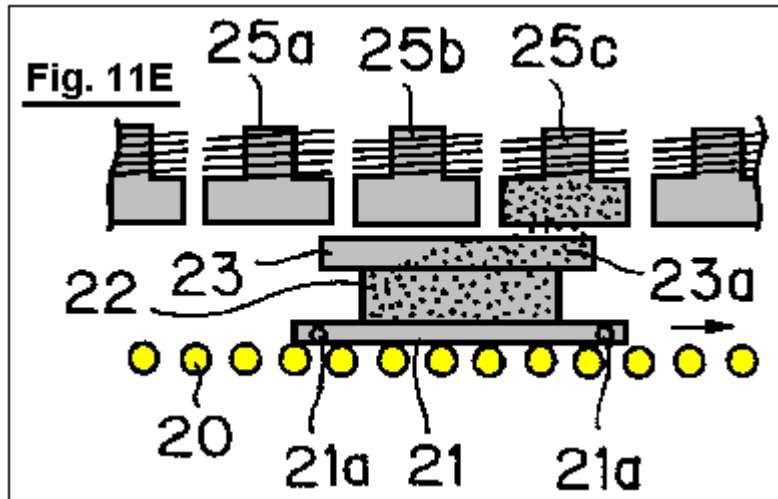

DETAILED DESCRIPTION OF PREFERRED EMBODIMENTS

Preferred embodiments of the invention will be explained in detail below with reference to the attached drawings.

According to a first embodiment of the invention, a rotational output shaft 11 is mounted in a bearing between front and rear side plates 10a of a support member 10 through bearings 11a, as shown in Fig.1 and Fig.2. A ring of permanent magnets 13 are fitted over the opposite ends of the output shaft, inside the side plates 10a and these move with the rotor shaft 11. The permanent magnets are magnetised in the axial direction. A magnetic body 14 is rigidly mounted between each of the side plates 10a of the rotor shaft 11 and the permanent magnets 13. Each of these magnetic bodies 14 has alternate notches 14a and magnetic teeth 14b. It should be noted that the flux of the permanent magnets 13 passes through the respective magnetic bodies 14. For example, Fig.1 shows the magnetic body 14 with three notches 14a and three magnetic teeth 14b. The permanent magnets 13 and magnetic bodies 14 are positioned co-axially with the rotor output shaft 11. The corresponding permanent magnets 13 and magnetic bodies 14 are shown connected together by bolts 15 so as to form a rotor 12 which is attached to the rotational output shaft 11.

It should be noted that the support member 10 and rotational output shaft are both made from a non-magnetic material. The support member 10 may be formed, for example, from stainless steel, aluminium alloys, or synthetic resins, while the rotational output shaft 11 may be formed from stainless steel, for example. Thus, the magnetic circuit formed by the permanent magnet 13 and magnetic body at one axial end of the rotational output shaft 11 and the magnetic circuit formed by the permanent magnet 13 and magnetic body at the opposite axial end of the output shaft, are independent of one another. The magnetic bodies 14 may be formed from magnetic materials having a high magnetic permeability, such as various kinds of steel materials, silicon steel plate, permalloys, or the like.

The stator contains electromagnets 16a through 16l, which are positioned between the side plates 10a. The electromagnets are evenly spaced around the magnetic pieces 14 so that they surround the magnetic bodies. As shown in Fig.1, twelve electromagnets may be used. The magnetic circuit of each of the electromagnets 16a

through **16l** is arranged so as to be independent of each other, so that no flux of a magnetised electromagnet passes through the iron cores of the adjacent electromagnets.

The iron cores of the electromagnets **16a** through **16l** are positioned parallel to the rotor axis shaft **11**, and positioned with only a slight gap between them and the magnetic bodies **14**.

Some of the electromagnets **16a** through **16l** are located at a position corresponding to boundary portions **14c1** through **14c6** between the notch **14a** and the magnetic tooth **14b**. For example, as shown in **Fig.1**, electromagnets **16a**, **16b**, **16e**, **16f**, **16i** and **16j** are positioned opposite the boundary portions **14c1**, **14c2**, **14c3**, **14c4**, **14c5**, and **14c6**, respectively.

Fig.5A shows a path of magnetic flux created by the permanent magnet **13** when the electromagnets are not excited or magnetised, while, **Fig.5B** shows a path of magnetic flux created by the permanent magnet **13** and a path of magnetic flux created by the windings of the electromagnets when the electromagnets are magnetised. As will be clear from **Fig.5A** and **Fig.5B**, both paths of magnetic flux represent a uni-polar distribution in which N-pole or S-pole evenly appears at the opposite axial ends. When the electromagnets are magnetised, the magnetic fields of the permanent magnet and electromagnets co-operate or interact with each other so as to generate a rotational torque.

Excitation change-over mechanism **17** for sequentially exciting or magnetising the electromagnets **16a** through **16l** is basically consisted of a conventional excitation circuit for supplying direct current to each windings of the electromagnets **16a** through **16l**. In this embodiment, the change-over portion for changing electric feed to the electromagnets **16a** through **16l** includes a plurality of optical sensors **18** and a light shield plate **19** for turning the optical sensors ON and OFF as shown in **Fig.6**.

The optical sensors **18** are spaced apart from one another with a space between them for permitting the light shield plate **19** to pass through a light emitting element and a light receiving element. The optical sensors **18** are disposed in the outer surface of one of the side plates **10a** equally spaced apart along the circumference, so that they are positioned to correspond to the electromagnets **16a** through **16l** (for example, the optical sensor **18** is shown to be disposed in the outer surface of the rear side plate). The light shielding plate **19** is fixed to the rotational output shaft **11** at the end thereof, the light shielding plate protruding from the rear side plate **10a** on which the optical sensors are mounted.

According to the illustrated embodiment, when a particular optical sensor **18** is blocked by the light shielding plate **19**, the electromagnet corresponding to such optical sensor **18** is supplied with electricity.

The operation of the first embodiment described above will be explained with reference to **Fig.4A** through **Fig.4H**.

When the electromagnets **16a** through **16l** are not supplied with electricity by means of the excitation changeover mechanism **17**, the electromagnets **16c**, **16d**, **16g**, **16h**, **16k** and **16l** opposed to the magnetic teeth **14b** with a small gap between them merely serve as a magnetic material disposed within the magnetic field of the permanent magnet **13** (refer to shaded portion in **Fig.4A**), so as to absorb the magnetic teeth **14b**, and the rotor **12** remains stationary.

When the electromagnets **16a**, **16e** and **16i** positioned adjacent to the boundary portion **14c1**, **14c3** and **14c5** formed between the respective notches **14a** and the magnetic teeth **14b** are magnetised or excited simultaneously by means of the excitation change-over mechanism, as shown in **Fig.4B**, the magnetic field of the permanent magnet **13** and the magnetic fields of the electromagnets **16a**, **16e** and **16i** interact with each other, so that a magnetic flux **14d** passing through the magnetic body **14** instantaneously converges to the electromagnets **16a**, **16e**, and **16i**. In this way, the rotor **12** is imparted with a rotational torque in a direction in which the magnetic flux **14d** will be widened, i.e., counterclockwise direction as viewed in **Fig.4B**.

Fig.4C through **Fig.4G** illustrate change in the width of the magnetic flux **14d** in accordance with rotation of the rotor **12**. When the width of the magnetic flux becomes maximised, i.e., when only the magnetic teeth **14b** are opposed to the electromagnets **16a**, **16e** and **16i**, while the notches **14a** are displaced completely away from the electromagnets **16a**, **16e** and **16i**, the width of the magnetic flux **14d** is maximised. Thus, an absorption force acting between the permanent magnet **13** and the electromagnets **16a**, **16e** and **16i** is maximised. On the other hand, the rotational torque acting on the rotor **12** becomes zero.

Before the rotational torque acting on the rotor **12** becomes zero, i.e., as the boundary portion **14c1**, **14c3** and **14c5** approach another electromagnets **16b**, **16f** and **16j** positioned ahead of (with regard to the rotational direction), respectively, the electromagnets **16a**, **16e** and **16i** are demagnetised and the electromagnets **16b**, **16f** and **16j** are excited or magnetised by means of the excitation change-over mechanism **17**. Thus, the magnetic

flux **14d** converges toward the electromagnets **16b**, **16f** and **16j**, as shown in **Fig.4H**, so that a rotational torque acts upon the rotor, as described above.

Then, the electromagnets **16c**, **16g** and **16k** are excited. When the boundary portion **14c1**, **14c3** and **14c5** approach another electromagnets **16d**, **16h** and **16l** positioned ahead with respect to the rotational direction, in response to rotation of the rotor **12**, the electromagnets **16c**, **16g** and **16k** are de-magnetised and the electromagnets **16d**, **16h** and **16l** are energised or excited.

As explained above, sequential excitation or energising of the electromagnets **16a** through **16l** causes interaction between the magnetic flux of the permanent magnet **13** and the electromagnets **16a** through **16l**, whereby a rotational torque is applied to the rotor **12**.

When this occurs, a rotational torque is generated between one of the magnetic poles of the permanent magnet **13** (for example, N-pole) and the magnetic poles (for example, S-poles) of the electromagnets **16a** through **16l** positioned at their respective axial ends. A rotational torque is also generated between the other magnetic pole (for example, S-pole) of the permanent magnet **13** and the other magnetic pole (for example, N-pole) of each of the electromagnets **16a** through **16l** positioned at the other axial end.

It should be noted that, at one magnetic pole, for example N-pole, of the permanent magnet **13**, certain of the electromagnets **16a** through **16l** are magnetised only to S-pole, thus preventing formation of a magnetic circuit, due to passage of magnetic flux from the excited electromagnets through either of the adjacent electromagnets, which tends to bring about N-poles magnetically similar to the permanent magnet **13**. It is also noted that, at the other magnetic pole, for example S-pole, of the permanent magnet **13**, certain of the electromagnets are magnetised only to N-pole, thus preventing formation of a magnetic circuit, due to passage of magnetic flux from the excited electromagnets through adjacent electromagnets, which tends to bring about S-poles magnetically similar to the permanent magnet **13**. The magnetic flux of the permanent magnet **13** passes through the magnetic bodies **14** so as to be converged to the excited electromagnets (refer to the magnetic flux **14d** shown in **Fig.4** through **Fig.4H**), thus forming dead zones, through which no magnetic flux passes, in the magnetic bodies **14** at a position opposite to the un-excited electromagnets. Accordingly, no force is generated which would tend to prevent rotation of the rotor **12**.

In view of electric energy applied to the electromagnets **16a** through **16l**, substantially all the electric energy applied is used to contribute to the rotation of the rotor **12**. On the other hand, and in view of magnetic energy of the permanent magnet **13**, all the magnetic energy contributes to the rotation of the rotor **12**.

It is also noted that, since the notches **14a** and the magnetic teeth **14b** are alternately disposed in the outer periphery of the magnetic materials **14** in an acute angle configuration seen in **Fig.4A** to **Fig.4H**, and the electromagnets are disposed at a position each corresponding to the boundary portions between the notches and the magnetic teeth, it is possible for the line of the magnetic force, generated in each gap between the boundary portions and the electromagnets when the electromagnets are excited, to be inclined to a substantial degree, so that a sufficient degree of rotational torque may be obtained upon initial excitation of the electromagnets.

The result obtained during an actual running test of the motor according to the first embodiment is shown in **Fig.1** to **Fig.3**.

Pure steel was used as a magnetic material. The magnetic material was 30 mm in thickness and formed to have magnetic teeth of 218 mm diameter and notches of 158 mm diameter. A ferrite magnet was used as a permanent magnet. The magnetic force of the magnet was 1,000 gauss. Electric power of 19.55 watts was applied to the electromagnets at 17 volts and 1.15 amperes. The above conditions produced a rotational speed of 100 rpm, with a torque of 60.52 Kg-cm and an output of 62.16 watts.

Alternative embodiments will be explained below with reference to **Fig.6** through **Fig.9**.

The modified embodiment shown in **Fig.6** is similar to the motor presented as the first embodiment as shown in **Fig.1** through **Fig.3**, with the exception that each electromagnet **160** used as part of the stator, comprises an iron core **161** having a pair of legs **162** which extend towards the outer periphery of the magnetic bodies (outer periphery of the magnetic teeth **14b**), each of the legs being wound with coils **163**. The remaining components are basically identical to those in the motor shown in **Fig.1** through **Fig.3**. In **Fig.6**, the components similar to those in **Fig.1** through **Fig.6** are denoted by like reference numerals. It should be noted that each coil **163** is supplied with electricity so that one leg **162** (left-hand side in **Fig.6**) of each of the iron cores **161** is magnetised to be S-pole which is magnetically opposite to the magnetic pole (N-pole) of the confronting magnetic body **14**, while the leg **162** disposed at the other end of each of the iron cores is magnetised to be N-pole which is magnetically opposite to the magnetic pole (S-pole) of the confronting magnetic body **14**.

According to this modified embodiment, it is possible to significantly reduce leakage of the magnetic flux created by the electromagnets **160** in gaps each defined between the surfaces of the magnetic poles of the electromagnets **160** and the outer peripheries of the magnetic teeth **14b** of the magnetic bodies **14**.

An alternative embodiment shown in **Fig.7** is similar to the motor shown in **Fig.1** through **Fig.8**, with the exception that: an additional magnetic body **14** is mounted on the rotational output shaft **11** at its axial midpoint; two permanent magnets **130** are freely mounted on the output shaft **11** in the manner shown in **Fig.6**; and each iron core **165** is provided with three legs **166** positioned at the opposite axial ends and midpoint thereof and extending toward the respective outer periphery of the magnetic bodies, with the legs **166** positioned at axial opposite ends of the respective iron cores **165** being wound with a coil **167**, which form electromagnets **164**. The remaining components are substantially the same as those in the motor shown in **Fig.1** through **Fig.3**. It should be noted here, that the rotational output shaft **11** may be formed from either magnetic materials or non-magnetic materials.

As shown in **Fig.7**, each of the coils **167** is supplied with electricity so that the legs **166** positioned at the opposite axial ends of each of the iron cores **164** is magnetised to be S-pole which is magnetically opposite to the magnetic pole (N-pole) of the confronting magnetic body **14**. By this, the leg **166** positioned at the midpoint of the iron core **165** is magnetised to be N-pole which is magnetically opposite to the magnetic pole (S-pole) of the confronting magnetic body **14**.

In this embodiment, it is also possible, as in the modified embodiment shown in **Fig.6**, to significantly reduce the leakage of the magnetic flux generated by the electromagnets **164**. In addition to this, it is also possible to obtain a rotational torque between the leg **166** positioned at the midpoint of the iron core and the magnetic body **14** positioned at the axial midpoint of the rotational output shaft **11**. Accordingly, a higher rotational torque may be obtained with the same amount of electrical consumption, in comparison with the embodiment shown in **Fig.6**.

A further embodiment shown in **Fig.8** is similar to the motor shown in **Fig.1** though **Fig.3**, with the exception that a permanent magnet magnetised in the radial direction, rather than in the axial direction is employed. The permanent magnet **131** of an annular configuration has, for example, N-pole in the outer periphery and S-pole in the inner periphery. The permanent magnet **131** is received within a cavity **14e** provided in the respective magnetic body **14** at the intermediate portion thereof as disposed at the opposite axial ends of the rotational output shaft **11**. The remaining components are identical to those in the motor shown in **Fig.1** though **Fig.3**. The components identical to those in the motor shown in **Fig.1** though **Fig.3** are denoted by the same reference numerals. It should be noted that this embodiment may also employ the electromagnets **160** shown in **Fig.6**.

In this embodiment, the rotational output shaft **11** may be formed from magnetic materials, rather than non-magnetic materials.

Further embodiment shown in **Fig.9** is similar to the motor shown in **Fig.1** though **Fig.3**, with three exceptions. The first exception is that a permanent magnet magnetised in the radial direction, rather than in the axial direction is employed. The permanent magnet **131** having an annular configuration has, for example, N-pole in the outer periphery and S-pole in the inner periphery. The permanent magnet **131** is received within a cavity **14e** provided in the respective magnetic body **14** at the intermediate portion thereof as disposed at the axial opposite ends of the rotational output shaft **11**. The second exception is that an additional magnetic body **14** is disposed at the axial midpoint of the rotational output shaft **11**. Finally, the third exception is that the iron core **165** is provided with three legs **166** disposed at the axial opposite ends and the midpoint thereof, respectively, and extending toward the outer periphery of the magnetic body **14**, with the legs positioned at the opposite axial ends being wound with respective coils so as to form an electromagnet **164**. The remaining components are identical to those in the motor shown in **Fig.1** though **Fig.3**. The components identical to those in the motor shown in **Fig.1** though **Fig.3** are denoted by the same reference numerals.

As shown in **Fig.9**, each coil is supplied with electricity so that the legs **166** disposed at opposite axial ends of the iron core **165** are magnetised to be S-pole which is magnetically opposite to the magnetic pole (N-pole) of the confronting magnetic body **14**. By this, the leg **166** disposed at the midpoint of the iron core **165** is magnetised to be N-pole which is magnetically opposite to the magnetic pole (S-pole) of the confronting magnetic body **14**.

According to the embodiment described above, the rotational output shaft **11** may be formed from magnetic materials rather than non-magnetic materials. With this embodiment, it is possible to obtain the same effect as that obtained with the embodiment shown in **Fig.7**.

Further the alternative embodiments shown in **Fig.10A** to **Fig.10C** are similar to the motor shown in **Fig.1** though **Fig.3**, with the exception that: like the embodiments shown in **Fig.8** and **Fig.9**, an annular permanent magnet **131** is employed which is received in a cavity **140e** provided in the central portion **140** of the magnetic body **140**; the magnetic body **140** is provided with notches **140a** in the outer peripheral portion thereof, so that the gap G

between the magnetic body **140** and the electromagnet becomes gradually broader in the rotational direction of the rotor; and the electromagnets confronting to the gap G with an intermediate width as positioned between the electromagnets confronting to the gap G with a narrower width and the electromagnets confronting to the gap G with a broader width are excited or magnetised in a sequential manner. The remaining components are identical to those in the motor shown in **Fig.1** through **Fig.3**. In **Fig.10A** to **Fig.10C**, the components identical to those in **Fig.1** through **Fig.3** are denoted by the same reference numerals. In this regard, it should be noted that reference numeral **140d** indicates magnetic flux passing through the magnetic body **140**, so as to illustrate converged condition of such magnetic flux upon excitation of the electromagnets.

In the embodiment Just described above, it is possible to rotate the rotor in the counter clockwise direction as viewed in **Fig.10A**, for example, by exciting the electromagnets **16a**, **16d**, **16g** and **16j**, as shown in **Fig.10A**, then, the electromagnets **16c**, **16f**, **16i** and **16l**, as shown in **Fig.10B**, and then the electromagnets **16b**, **16e**, **16h** and **16k**. According to this embodiment, it is possible to obtain a stable rotational force, as well as a higher rotational torque, even though number of rotations is reduced in comparison with the above embodiment.

As shown in **Fig.10A**, four notches **140a** are provided. It should be noted, however, that two or three notches may be provided. It is also possible to attach the magnetic material **140** to the rotational output shaft **11** in an eccentric manner in its entirety, without providing notches **140a**.

Fig.11A through **Fig.11H** are illustrative diagrams showing the operation of the second embodiment of the invention when developed into a linear motor type.

According to this embodiment, a movable body **21** is adapted to be moved along a linear track **20** of a roller conveyor type. The track includes a frame on which a plurality of rollers are positioned in parallel relative to one another. A permanent magnet **22** is mounted on the movable body **21**. A magnetic body **23** of a plate-like configuration is fixed to the permanent magnet **22** in the upper surface, so as to form a movable element. It should be noted that magnetic flux from the permanent magnet **22** passes through the magnetic body **23**. A plurality of electromagnets **25a**, **25b**, **25c**, **25d** and so on are disposed above the movable element **24** along the linear track positioned parallel to each other. These electromagnets constitute a stator **25**. Magnetic circuits of the electromagnets **25a**, **25b**, **25c**, **25d**, and so on, are independent from one another, so that the electromagnets are magnetised in a sequential manner by means of excitation change-over mechanism (not shown), so as to have a magnetic polarity opposite to the magnetic pole of the permanent magnet **22**. Power output shafts **21a** are attached to a side surface of the movable body **21**.

Operation of the above second embodiment will be explained below.

As shown in **Fig.11A**, and when no electricity is supplied to the electromagnets, the electromagnets **25a** and **25b** positioned Just above the movable element **24** are subjected to magnetic field of the permanent magnet **22** (refer to shaded portion in **Fig.11A**). Thus, such electromagnets magnetically absorb the magnetic body **23**, so that the movable element **24** remains to be stopped.

As shown in **Fig.11B**, and when the electromagnet **25c**, positioned ahead with respect to the direction in which the movable element **24** moves, is excited, the magnetic field of the permanent magnet **22** and the magnetic field of the electromagnet **25c** interact with each other, so that magnetic flux **23a** passing through the magnetic body **23** converges instantaneously toward the electromagnet **25c**. By this, the movable element **24** is magnetically absorbed to the electromagnet **25c**, so that it is moved along the linear track **20** under the propulsive force acting in the direction in which the width of the magnetic flux **23a** becomes broader, i.e., in the direction of an arrow mark shown in **Fig.11B**.

Fig.11C through **Fig.11E** illustrate a change in width of the magnetic flux **23a** in response to movement of the movable element **24**. At the point at which the width of the magnetic flux **23a** becomes maximised, i.e., when the forward end of the magnetic material **23** of the movable element **24** is positioned just before passing by the electromagnet **25c**, the width of the flux **23** becomes maximised. At this time, magnetic absorption acting between the permanent magnet **22** and the electromagnet **25c** becomes maximised, but the propulsive force acting on the movable element becomes zero.

Before the propulsive force acting on the movable element **24** becomes completely zero, i.e., when the forward end of the magnetic body **23** of the movable element **24** is about to pass the electromagnet **25d**, the excitation changeover mechanism is actuated so as to stop excitation of the electromagnet **25c** and so as to initiate excitation of the electromagnet **25d**. Thus, the magnetic flux **23a** converges to the electromagnet **25d**, as shown in **Fig.11F**, so that a propulsive force acts on the movable element **24**, as in the previous stage.

Subsequently, and in response to further movement of the movable element **24**, the width of the magnetic flux **23a** is reduced as shown in **Fig.11G** and **Fig.11H**, and thus a similar operation will be repeated.

The sequential excitation of the electromagnets, as explained above, causes interaction between the magnetic fields of permanent magnet **22** and electromagnets, whereby a propulsive force is applied to the movable element **24**.

It should be noted that, when the magnetic polarity of the permanent magnet **22** confronting the electromagnets is assumed to be N-pole, the electromagnet **25c** is magnetised solely to be S-pole, so as to prevent formation of a magnetic circuit by virtue of passage of magnetic flux from the electromagnet **25c** through to the adjacent electromagnets **25b** and **25d**, which formation, if it occurs, tends to cause the polarity of the electromagnets to be N-pole identical to the magnetic pole of the permanent magnet **22**. Accordingly, and in a manner similar to that in the first embodiment, no force is generated which tends to interfere with movement of the movable element **24**.

In the present invention, a plurality of electromagnets serving as a stator are so arranged that their respective magnetic circuits become independent from one another. The electromagnets are also arranged so that they are solely magnetised or excited to have a magnetic polarity opposite to the magnetic pole of the confronting permanent magnet. Thus, each electromagnet is prevented from becoming magnetised to the same polarity as that of the permanent magnet, which may occur when magnetic flux from a particular electromagnet passes through to adjacent electromagnets. Accordingly, no force will be exerted which tends to interfere with the intended movement of a rotor or a movable element. As a result, electric energy applied to the electromagnets may be efficiently utilised, while, at the same time, magnetic energy contained in the permanent magnet may also be efficiently utilised.

The coils constituting the electromagnets are consistently supplied with electric current with the same polarity, without any change, so that heating of coils may be prevented. Further, it is possible to obviate the problems of vibration and noise which might occur due to a repulsive force being generated when polarity of an electric current supplied to the coils is changed.

ENERGY GENERATION SYSTEM HAVING HIGHER ENERGY OUTPUT THAN INPUT

This patent covers a device which is claimed to have a greater output power than the input power required to run it.

ABSTRACT

A system for generating obvious work motion, or electromagnetic energy (fields of force) or electric current utilising the electromagnetic energy which makes up a matter and results in a greater output of energy, than the initial input of conventional energy means and teachings. A first exemplary embodiment (Fig.1) of the generator uses a contained fluid (117) surrounding a series of aligned magnets (120); while a second exemplary embodiment (Fig.3) uses a special material (201) held stationary between two static magnets (202, 203), the special material having its atoms aligned but maintaining the resulting magnetic field at least substantially within its boundary surface; while third and fourth exemplary embodiments (Fig.5 and Fig.6) utilise a relatively heavy coil (205) made up of relatively large diameter wire of relatively great length and number of loops and length and a relatively small energising current to drive a rotatable permanent magnet (200).

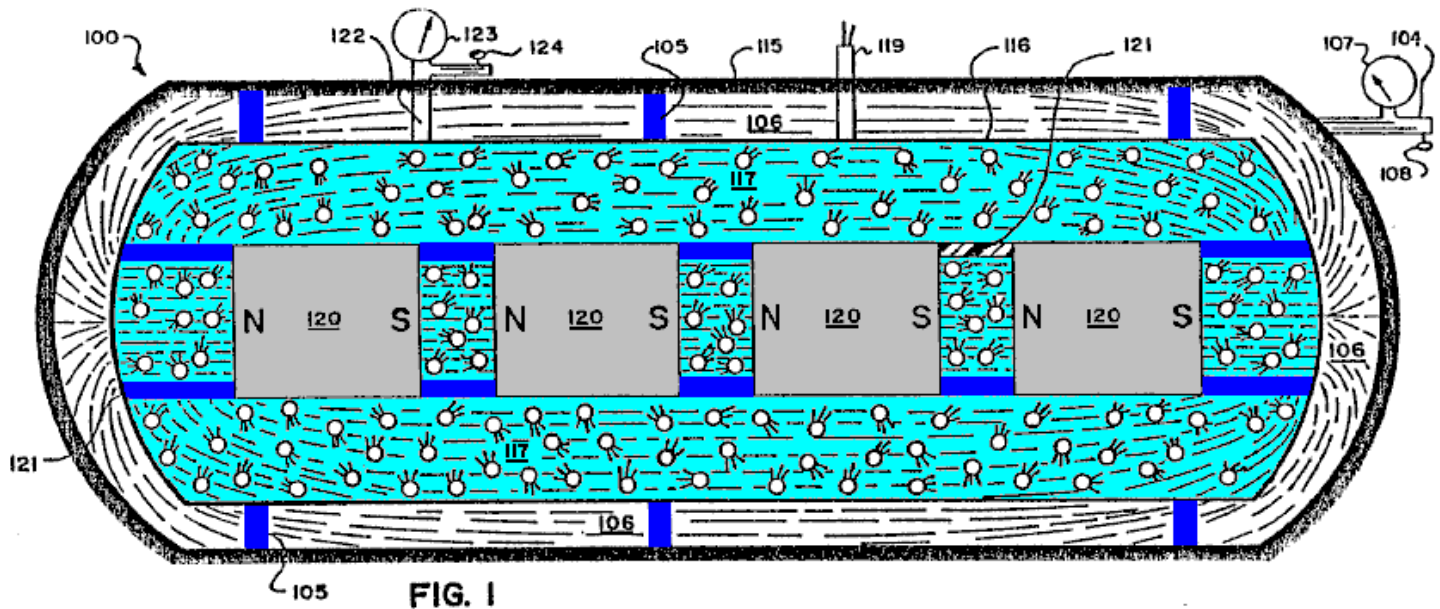

DESCRIPTION

BACKGROUND OF THE INVENTION

1. Field of the Invention:

The present invention relates generally to devices or systems (including methods) for generating usable energy such as for example electrical energy from electromagnetic fields, electrical energy or electromagnetic fields from matter, and more particularly to devices or systems (including methods) for producing electrical current flow for use as electrical power, and magnetic fields of force which cause motion (obvious work) or electrical current flow or for increasing electromagnetic potential energy available for use or mechanical energy available for use.

2. Prior Art:

There have been many devices proposed over the years for producing electrical-energy, with mechanical friction, thermo-electricity, photoelectricity, piezoelectricity, electrochemistry and electromagnetic induction being the chief forms of primary energy capable of producing electricity. Of these, the only significant source of commercial electrical power has been the mechanical actions of electric generators, and for mobile electric power the chemical action of batteries has been important. Usable motion has resulted from the interactions between the input of electrical energy and the magnetic and/or electromagnetic fields of force (electric motors) and heat or light as a result of input of electrical current through conventional mechanical systems, heaters, lightbulbs, etc.

All of the prior art systems are designed accordingly to rigid mathematical laws taught both in physics and electrical engineering which coincide with the hypothesis rigidly accepted by the industrial and scientific communities concerning the Second Law of Thermodynamics (1850).

From the foregoing generally accepted hypothesis it has also been generally accepted and rigidly taught in physics and electrical engineering that the electric current flowing in a closed circuit from a battery, electric generator, etc.

is used up in the mechanical device being operated by this flow of electric current, and that all such electric current producing systems would only put out at most work equal to the work initially put into the system, or in accordance with generally accepted laws stating that a particular electrical generating system was only capable of a given output of energy and no more.

These beliefs have till this date still remained rigid in both the industrial and scientific communities in spite of proof of Einstein's equation $E=mc^2$. Nuclear reactors convert matter into usable electromagnetic energy in the form of heat, which converts water into steam to turn conventional turbines for production of electric current by conventional electrical generating means. This system is extremely inefficient using less than 1% of the energy of the atom and producing a deluge of contaminated materials which has caused a serious problem as to safe disposal.

Additionally, the basic electrical generators in use throughout the world today utilise the principle of causing relative movement between an electrical conductor (for example a rotor) and a magnetic field produced by a magnet or an electromagnet (for example a stator), all using the generally accepted hypothesis that the greater the relative speed or movement between the two are concerned and the more normal or perpendicular the relative movement of the conductive material to the lines of force of the electromagnetic field, the greater will be the efficiency of the prior art electrical generator. Additionally, all of the prior art systems are based on the generally accepted hypothesis that the greater the electrical conductivity of the material being moved through the field, the more efficient will be the electrical generation.

From the foregoing generally accepted hypotheses, it also has been generally accepted that there should always be movement between, for example, the rotor and stator elements, and that only generally accepted electrical conductors, that is materials with high electrical conductivity, will effectively serve in an electrical generation system.

However, in one of the systems (**Fig.3**) of the present invention, electrical generation can occur with relatively static elements and with materials that are not generally considered to be of high electrical conductivity, although, of course, the present invention likewise can utilise relatively moving elements as well as materials of generally accepted high electrical conductivity, if so desired, as occurs in the systems of the present invention illustrated in **Fig.5** and **Fig.6**.

The prior art has failed to understand certain physical aspects of matter and the makeup of electromagnetic fields, which failure is corrected by the present invention.

BRIEF DESCRIPTION OF DRAWINGS

For a further understanding of the nature and objects of the present invention, reference should be had to the following detailed description, taken in conjunction with the accompanying drawings, in which like parts are given like reference numerals and wherein:

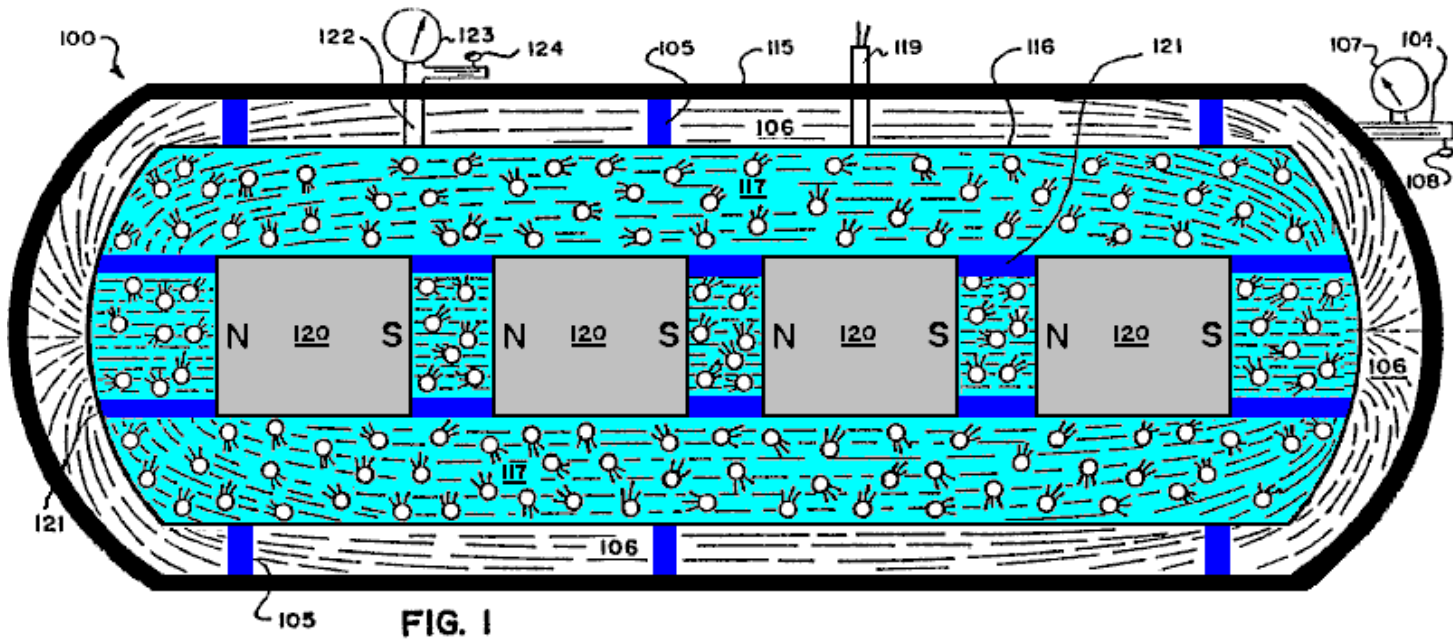

Fig.1 is a schematic, side view in generalised, representational form of a first embodiment of an electrical generator based on the principles and guidelines of the present invention.

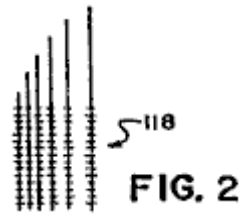

Fig.2 is a close-up view in general form of an electrical charge pick-up element which can be used in the generator illustrated in **Fig.1**.

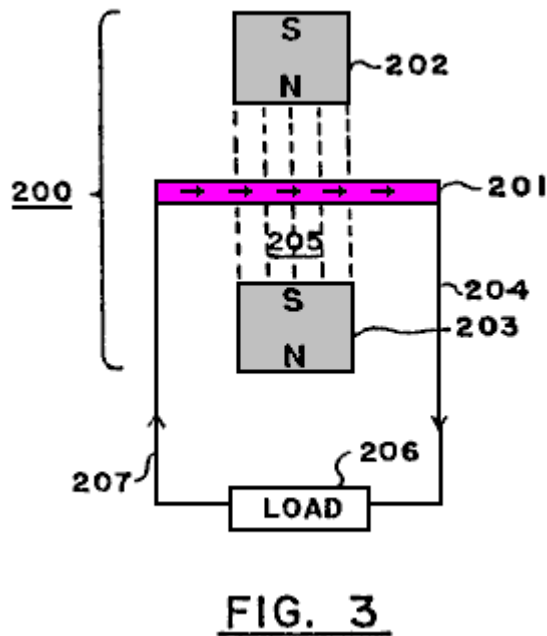

Fig.3 is a schematic view in generalised, representational form of a second embodiment of an electrical generator based on the principles and guidelines of the present invention.

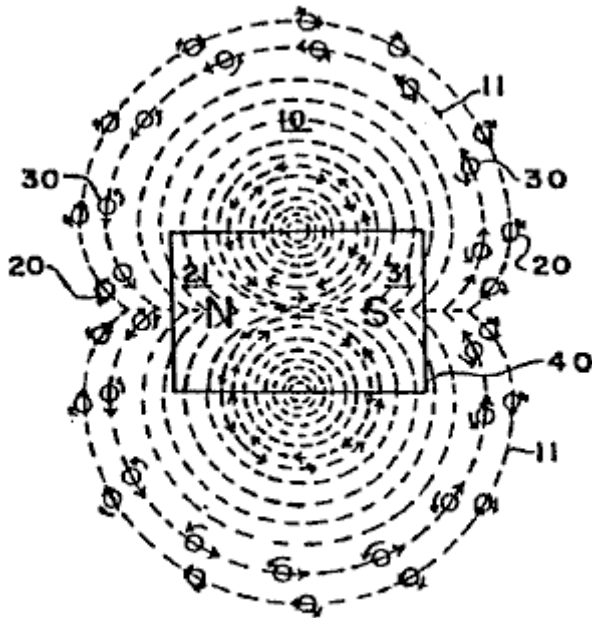

FIG. 4

Fig.4 is a schematic view in generalised, representational form of the negative and positive particles exhibiting gyroscopic actions which emanate from a magnet to form an electromagnetic field.

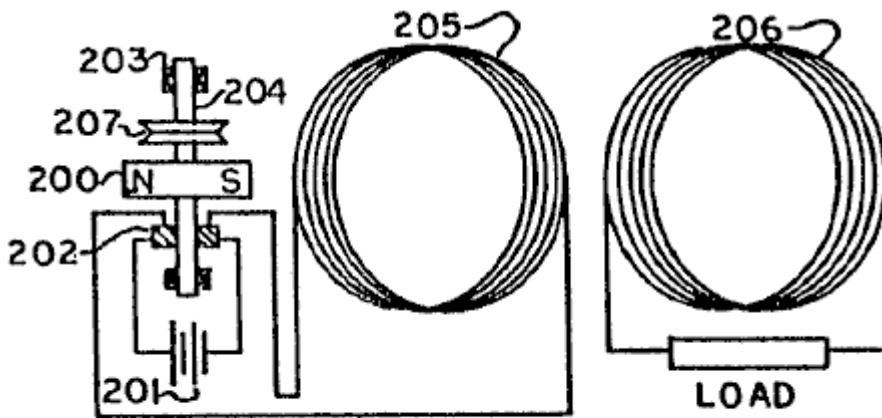

FIG 5

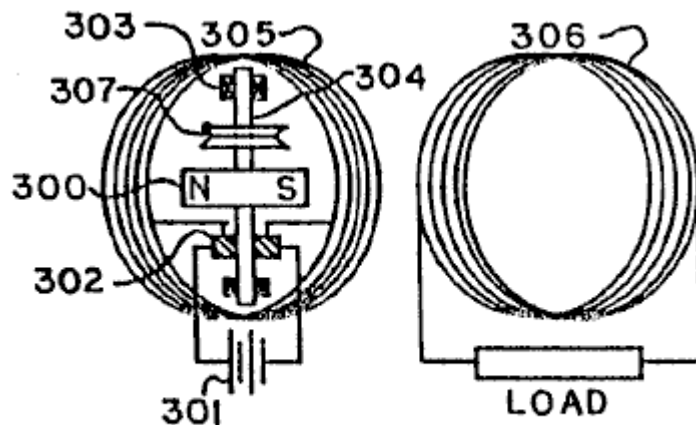

FIG 6

Fig.5 and **Fig.6** are schematic views in generalised, representational form of third and fourth embodiments of a combined electrical generator and motor utilising a static, relatively large coil energised by a relatively low current

driving a rotatable magnet, wherein in the embodiment of **Fig.5** the rotatable magnet is positioned along side of the coil and in the embodiment of **Fig.6** the rotatable magnet is positioned within the open core of the coil.

DETAILED DESCRIPTION OF-PREFERRED EMBODIMENTS:

Basic Principles and Guidelines

In accordance with the principles of the present invention and as generally illustrated in **Fig.3**, an electromagnetic field **10** comprises flows of quanta or particles **20, 30** of electrical energy flowing from each of the poles **21, 31** of a magnet (or electromagnet) **40** to the other pole, following the "lines of force" **11** of the electromagnetic field. These particles **20, 30**, believed to be travelling at the speed of light, are always coming out of one end **21, 31**, respectively, of the magnet **40** and going into the other pole **31, 21**, respectively, flowing from a relatively high energy source to a low energy source.

These particles **20, 30** are, it is believed, negative and positive charges and have a spin producing a gyroscopic motion and follow the mechanical laws of gyroscopic action.

The mass of each of the particles **20, 30** equals the energy of the particle divided by the speed of light squared. The peripheral speed of the gyroscopic spin of the particles is believed to be the speed of light.

For purposes of illustration only and as a matter of nomenclature, the positive charge particle **20** is going in one direction ("N" to "S") with a clockwise spin, and the negative charge particle **30** is going in the opposite direction with a counter-clockwise spin. Of course, if a particle such as **20** or **30** is flipped around one-hundred-and-eighty degrees, it becomes the opposite charge or type of particle.

The electromagnetic field **10** is thus the orderly flow of the positive and negative charges **20, 30** moving at the speed of light from the north and south poles **21, 31**, to the south and north poles **31, 21**, respectively, and follow the paths of what is termed in the art as the "lines of force" **11** of the electromagnetic field **10**.

As is known from the laws of gyroscopes, a gyroscopic particle or body moves at right angles to the direction of an applied force. Therefore, when a force is applied to the electrical energy particles **20, 30**, they will move at right angles to that force.

It should also be noted from known gyroscopic laws that the electrical energy particles **20, 30**, when they move with their gyroscopic axis straight into an object, tend to knock that object straight, but, if that object hits the particles at an angle to the axis other than at zero or one-hundred-and-eighty degrees, the particles are moved off at an angle from the straight.

Additionally, it is noted that a magnetic field caused by a current flowing through a wire comes from negative and positive particles, such as **20, 30**, with a net flow of such particles going in the same direction but with opposite spin.

In the system and method of the present invention, the foregoing principles serve as guidelines in the present invention.

Reference is further had to pages DD23 through DD27 of the Disclosure Document and to page 8, line 26 through page 11, line 23 of the prior application Serial number 25,907 and its Figures 7 - 10.

From the foregoing disclosures, many different devices, structures, and methods are possible to embody the principles and guidelines of the system of the present invention, which will in general utilise a material or substance or structure to place a force at the proper angle to the gyroscopic particles **20, 30** wherein the particles **20, 30** follow a path or paths which do not cancel one another out, thereby producing electrical current at appropriate outputs for further use or for increasing available potential electrical energy for ultimate use.

-First Embodiment (Fig.1)

One possible, exemplary embodiment using the principles of the system of the present invention is schematically shown in the generalised illustration of Fig.1.

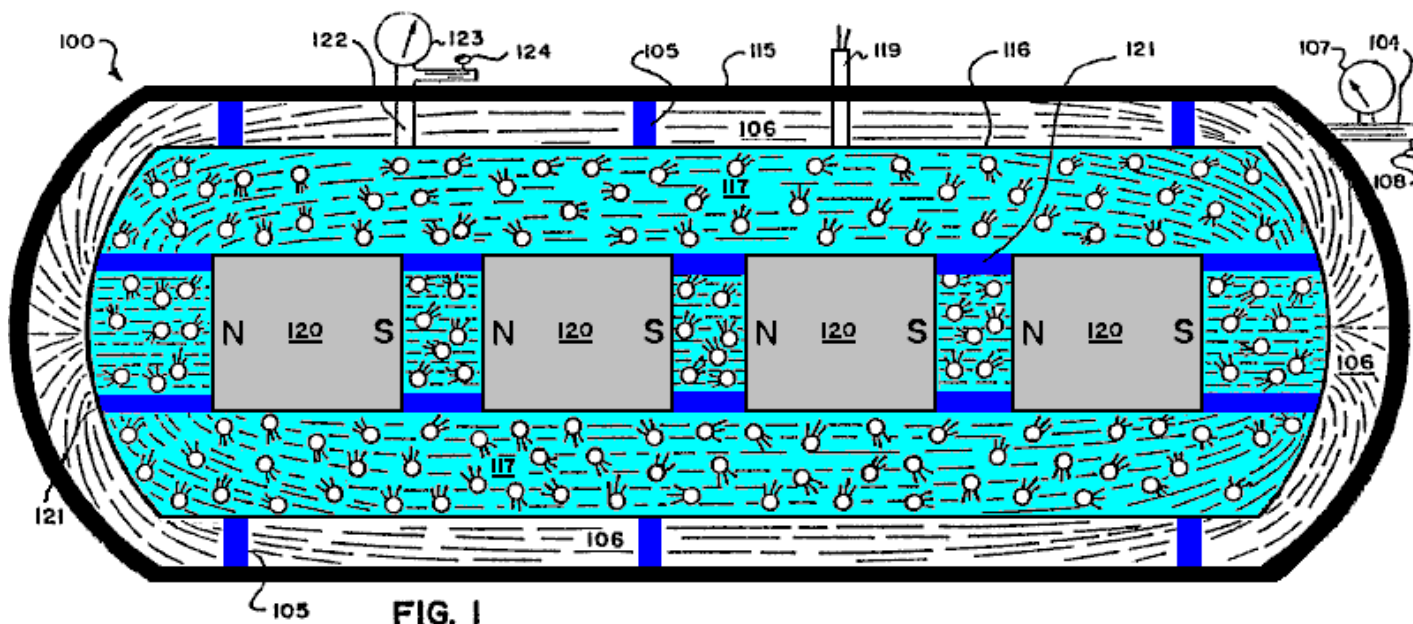

As illustrated in Fig.1, there is provided an electrical current generator 100 comprising an outer keeper housing 115 and an inner, pressure containing, closed housing 116 supported therein by insulating supports 105. A vacuum exists in the area 106 between the two housings 115, 116, which vacuum is regulated and induced by means of the vacuum line 104 with its gauge 107 and its control valve 108. The outer housing 115 acts as a keeper for magnetic fields of force, and can be made for example of soft iron, while the vacuum in area 106 prevents the leakage or discharge of static electrical charges which might build up on the exterior of the inner housing 116.

A gas or gas-liquid mixture 117 which may also include solid particles such as for example lead or brass filings, is included within the inner housing 116 surrounding a series of aligned magnets 120 carried by insulating braces or supports 121 and producing a high, combined electromagnetic field. The magnets 120, which can for example be cryogenic magnets, have their "north" and "south" poles aligned (as illustrated by the "Ns" and "Ss") so that their magnetic fields reinforce one another.

The level of the gas or gas-liquid mixture 117 in the housing 116 is regulated by means of the line 122 with its gauge 123 and control valve 124. Electric current output wires 119 are provided and extend down to electrically connect with a wire pick-up system 118 (shown in close-up in Fig.2), which can be for example in the form of very small wires forming a closely spaced network or mesh or of a porous conducting metal body or sheet, located in and extended throughout the fluid 117 in the housing 116.

It is noted that a thimbleful of gas contains a fantastically large number of extremely tiny bodies which are in continuous, random motion moving at extremely high speeds. Hence, the fluid 117 continuously applies a force to the gyroscopic particles (analogous to particles 20, 30 of Fig.3) moving at the speed of light ' in the high electromagnetic field (produced by the magnets 120) as they continuously collide with each other, which results in the fluid 117 becoming electrically charged. The charged fluid 117 discharges its electrical charge to the pick-up wire network 118 positioned in the fluid, and the electric current so produced and generated is taken off for use via the electrical output wires 119.

As an alternative to having internally contained magnets 120, the electromagnetic field needed in the fluid 117 could be produced by a source located outside of the confines of the fluid 117 as long as a significant field was produced within the fluid 117.

-Second Embodiment (Fig.3)

A further exemplary, generalised embodiment utilising the principles of the system of the present invention is shown in schematic form in **Fig.3**.

The electrical current generator **200** of **Fig.3** comprises an extended member **201** of a special material having its atoms especially aligned to produce electric current when positioned in an electromagnetic field but which does not on its own exhibit any substantial magnetic field outside of its boundary surfaces but substantially contains the field within itself. This is in contrast to "magnetic" materials which likewise have atom alignment but which also exhibit or produce a substantial magnetic field in the area surrounding it.

The generator **200** further comprises for example two magnets **202, 203**, with their north and south poles facing each other, with the member **201** positioned between them, and with the three elements **201-203** held static with respect to each other. Because of the special nature of the material of the member **201** and its special atom alignment, it will produce a direct current through output line **204** as a result of the gyroscopic actions of the particles of the electromagnetic field **205** produced by the facing magnets **202, 203**, on the especially aligned atoms in member **201**, which phenomenon occurs even when and even though the member **201** is completely static with respect to the magnets **212, 203**.

However, it may be desirable in some applications to allow or produce some relative movement between the generator elements **201-203**. The output line **204** extends to an appropriate "load" **206** for using the electrical current generated by the generator **200**. A return line **207** completes the circuit back to the member **201**.

Based on experiments to date, it is believed that brass and lead are materials which can have their atoms especially aligned to interact with the gyroscopic particles (analogous to particles 20, 30) flowing between the magnets 202, 203 and will substantially contain within their surface boundaries the magnetic field produced by the aligned atoms or molecules.

With respect to producing the proper material with atom alignment for the member **201**, it is noted that most materials seem to align their atoms in random directions when formed by conventional methods of production. However, it can be observed that certain materials can be made magnetic by putting the material in an electromagnetic field while cooling from a temperature of around a thousand degrees Centigrade. The magnetism is the result of atom alignment of the material in a given direction (see pages DD19 through DD21 of the Disclosure Document). All materials are affected so as to align parallel or across lines of force when in a powerful electromagnetic-field. Accordingly, if a material while being formed is cooled in an extremely powerful electromagnetic field, the atoms of the material will take a particular alignment. The atom alignment direction could be varied depending on whether the electromagnetic field was aligned with the material or at a ninety degree angle to the material. This would result in the atoms of a material having their particular electromagnetic spin direction primarily along the same axis.

However, merely having atom alignment is not sufficient. Additionally the material for the invention should be such that it exhibits very little if any magnetic field in the area surrounding it. Thus it should be noted that the exterior electromagnetic field that occurs from the atom alignment of the conventional magnet is not duplicated in the material of the invention, because the electromagnetic energy resulting from atom alignment in the material of the invention will be primarily contained within the boundaries of the material. It is believed that lead, made superconductive by immersion in a bath of for example liquid helium, is such a special material and could for example serve as the material for member **201**.

This then results in having a material which would place a force at the proper angle on the gyroscopic type particles moving in the electromagnetic field so as to cause an EMF to be produced even when the material was sitting still. (See also first paragraph of page DD23 and paragraphs four, A through E, of page DD19 of the Disclosure Document).

It is believed that high, contained pressures, as well as other methods, can also probably produce atom alignment as the atoms of a conductor or any material will react to sufficient external force. (See first paragraph of page DD35 of the Disclosure Document). This possibility is also indicated by the fact that hard knocks or impacts will demagnetise a magnet.

The proper procedure of material production in achieving atom alignment with internally contained fields of force will cause the controlled release of electrical energy in electromagnetic fields of force when the material of the invention is placed in the lines of force of the electromagnetic field.

-Third and Fourth Embodiments (Fig.5 and Fig.6)

A. Related Principles

1. Numerous scientific tests and experiments made by the inventor indicate that the magnetic field resulting from an electrical current flowing through a conductor is the result of atom alignment within that conductor at an extremely high speed with an ability to reverse atom alignment just as rapidly without the magnetic hysteresis associated with conventional materials considered "magnetic." Prior to this time it has been believed and taught by the scientific community that the magnetic field associated with an electric current carrying conductor was the result of the electric current itself and not of the conductor material, for example copper, which was considered to be "nonmagnetic." Even the inventor was influenced and misled by these teachings and attempted to mechanically explain and justify the prior teachings, as is seen on page DD-27 of the Disclosure Document which is an important part of this patent application.

However, as taught in the present invention, what mechanically happens is that the gyroscopic particles making up the electric current moving in a conductor interact with the electromagnetic makeup of the atoms of the conductor, causing them to align extremely rapidly, thereby then releasing some of their electromagnetic make-up in the form of a magnetic field exactly as explained in great detail for conventional magnetic materials in the Disclosure Document.

This is easily proven and understood by taking for example, a size 14-gauge conductor one foot long, winding it into a coil and connecting the coil to a meter and a 1.5 volt battery. The total current registered on the meter will be 1.5 amps and the strength of the magnetic field created from the short conductor will be extremely small. Next, the same type of test is run again but with the length of the conductor increased to for example two thousand feet, but still in a coil. The total current registered on the meter will now be considerably less, but the strength of the magnetic field given off from the conductor will now be extremely large!

This shows that the magnetic field is not from the electric current flow, but is the result of the interactions of the gyroscopic particles which make up the electric current interacting with the atoms of the conductor! This causes the gyroscopic particles of the electric current not to be able to make the circuit back to the battery so quickly, and therefore the meter shows less current used.

The magnetic field is the result of the atom alignment of the conductor. The more atoms in a conductor (up to a point), the stronger the magnetic field produced from a given amount of electric current input. Again, this is proven by changing the diameter of the conducting wires, and, with the lengths being the same, the strongest magnetic field will result from the conductor with the largest diameter. The reason for this is that there are more conducting atoms to interact with the gyroscopic particles of the electric current moving through the conductor, which results in a greater number of conducting atoms being aligned, thereby then releasing some of their electromagnetic make-up, exactly as has been explained in great detail in the Disclosure Document as being possible for all matter.

If the magnetic field produced was strictly based on the amount of current going through a conductor, as taught in the prior art, then the strongest magnetic field would result when current went through a large diameter and short length conductor, because the current flow through the entire circuit is greatest at that time. However, experiments prove that the shorter a conductor is made, the greater the current flow through the entire circuit and the less strength of the magnetic field surrounding that conductor. The longer that same conductor is made (up to a point), the greater the magnetic field surrounding the total mass of the conductor and the less current that makes the complete circuit of the entire system. Reason: more atoms!

2. Numerous scientific tests and experiments made by the inventor also indicate that the magnetic field created when an electric current moves in a conductor does not use up measurable energy when performing obvious or non-obvious work, force or power. This is true no matter how strong or how immense the power of the motor or electromagnets is.

Reason: the magnetic field coming from the conductor is the result of extremely quick atom alignment within that conductor. Therefore the energy in the magnetic field is the energy that makes up the atoms of the conductor! This energy is literally Einstein's equation of $E=MC^2$, and therefore the energy is believed to be moving at the speed of light.

This energy use cannot be measured by today's measuring instruments. This has been explained in great detail in the Disclosure Document and is believed to be true of all matter!

3. The same is true for the electric current that comes from a conventional battery. The electromagnetic energy coming from the battery is the energy that makes up the atoms of the material of the battery! Again this energy use is not measurable by today's measuring instruments. Electric meters of all types are simply mechanical

devices which measure the amount of electric current that comes into that instrument. They do not measure the amount of mass that has been converted into electromagnetic energy.

Present teachings in science state that the electric energy flowing from a battery is used up in the device operated by that flow of electric current. This is not true at all! The electromagnetic energy released from the atom make-up of a battery has a relatively infinite capacity to do obvious work, force, or power.

This is easily proven even with a small motor and a 1.5 volt battery. With a battery connected to motor to operate it and with a meter to take readings, the motor is then physically stopped from turning by physically holding or restraining the shaft. At that moment the motor is performing no obvious work, force or power, but the meter will register a greater flow of current. The magnets of the motor can be taken out and the reading will still be the same. If the electric current was being used to operate the motor, the meter would register more current when the motor was running.

The electric current not only will operate the motor but, once it flows through the complete circuit back to the battery, it also does additional work based on Faraday's Laws of Electrolysis within the battery itself. What has happened is that the electromagnetic energy released from the atoms of the material of the battery once they have completed the circuit, then take a "short cut" and move large pieces of the mass of one material of the battery over to the other material of the battery. The inventor has stated and shown throughout the Disclosure Document that the effect of gravity was the non-obvious effect of electromagnetic energy. Once the materials of the battery have combined, the extreme desire for the two materials to merge is physically reduced. These materials will attempt this merger anyway possible and, if the electric current initially released from a battery is not allowed by mechanical means to complete the circuit back within itself, the electromagnetic energy then in the mechanical means will perpetually (in a relative, theoretical sense) perform obvious work, force or power. The reason: the force which initiated this flow of current (electromagnetic make-up of atoms of material) is constant, similar to hydraulic pressure, with the noticeable exception that it is moving it is believed at the speed of light and will interact with the electromagnetic make-up of the atoms of other materials, causing them to release some of their electromagnetic make-up in the form of a magnetic field. This then multiplies the capacity for doing obvious or non-obvious work, force or power, which can then react with another conducting coil or with the electromagnetic energy within the magnetic field of a conventional magnet and multiply this effect even further, and on and on and on for a relatively unlimited source of energy.

The same is true in not letting the current get back to a conventional generator. If a mechanical means is set up so that the electric current is "trapped," without completing a circuit, the gyroscopic particles of the current have a capacity for continuous work without increasing the power input into the generator system. However, if the circuit is complete and the electric current moving in the system does absolutely no obvious work, power or force, the gyroscopic particles making up the current on getting back to the generator will then increase the need for more power input into the system. Reason: the opposing effect of magnetic fields as defined in Lenz's Law. This law is simply an observation of this effect, which before now has never been fully understood.

4. Numerous scientific tests and experiments made by the inventor also indicate that there is a correlation between the electromagnetic spin orientation of the atoms of non-conductors, semi-conductors, and conductors, and the varying results achieved with an electric current in attempting to move through these materials, or when moving these materials through a magnetic field attempting to induce electric current. The property of resistance to electric current movement is generally speaking the same type factor already explained above for electric current producing a magnetic field when moving in a conductor.

The gyroscopic particles in a moving electric current interact with the atoms of the material through which the current is moving. Each atom can efficiently only interact with sun exact maximum amount of electric current, and, if exceeded, there is an interruption of orderly movement. Then the angle of release of the gyroscopic particles from the atoms are such that the electromagnetic release from those atoms are in the form of heat, exactly as explained in great detail in the Disclosure Document. This effect is easily observed by the fact that resistance decreases relative to an increase of the cross-section of the material. Reason: simply, more atoms within that given area, and, for a fixed input of electric current, there are more atoms to receive and interact efficiently with the gyroparticles making up the electric current.

Again the same is true for resistors designed for deliberately producing heat. Such resistors are not materials which are considered good conductors of electric current. It is stated and shown in great detail in the Disclosure Document that the electromagnetic spin orientation of the atoms of a non-conductor are different from that of conductor atoms, and therefore different results will occur from the same inputs of electromagnetic energy.

This is easily seen by the fact that, in a resistor, for a given amount of electric current input, the heat release increases as the diameter increases. What that means is that the property of resistance has decreased. On a conductor it is just the opposite. If the diameter is increased the resistance is decreased, but so is heat release. Again, this is an indication that the gyroparticles in the electric current movement interact with each atom of the

material. This same effect shows up again in conventional electrical induction from a conductor interacting with a magnetic field. Experiments by the inventor have indicated that the property of conventional induction is the result of the same property of resistance.

If one increases the diameter of a conductor, lengths staying the same, one decreases the amount of electric current produced relative to the total number of atoms within the conductors under consideration. Or, if one takes a given number of wires of the same diameter and length, and moves a magnet across them, the current produced will be considerably less, than if one takes the same diameter wire, but only one wire, and increases its length considerably and then forms it into a coil forming the same number of wires on any one side and then moves the same magnet across only one side of that coil, the electric current generated will then be considerably greater. Reason: the property of resistance. This is the mechanical effect within the gyroscopic electromagnetic make-up and orientation of the atoms of all materials which have the mechanical ability to perform a given task efficiently up to a point concerning input of additional electromagnetic energy and then mechanically causes varying results once this threshold is exceeded.

This and all the other thoughts and innovations in this and the previous disclosures of the previous applications and the Disclosure Document previously put forth show that there are many different mechanical ways to release a relatively unlimited source of energy from electromagnetic energy which makes up all matter and which results from this invention.

B. Working Prototypes

Fig.5 and **Fig.6** illustrate rough, working prototypes of this aspect of the invention. These embodiments are only relatively inefficient prototypes built by hand for the purpose of demonstrating the invention. It should be self-evident that the prototypes, by various mechanical means and designs, can easily be made extremely efficient and the illustrated embodiments are being presented only for general, representational purposes.

As is illustrated in **Fig.5**, there is provided a combined electrical current generator and an electromagnetic motor comprising a rotatably mounted, permanent magnet **200**, a battery **201**, brushes and commutator **202**, bearings **203** and power, mounting shaft **204**, and a first, primary, magnetic producing coil **205** and a second, secondary electric producing coil **206**. The two coils **205**, **206** are juxtaposed together in parallel disposition with concurrent core centre-lines, with the magnet **200** positioned alongside of coil **205** at or near its core centre-line with the rotational axis of the shaft **204** positioned orthogonally to the centre-line.

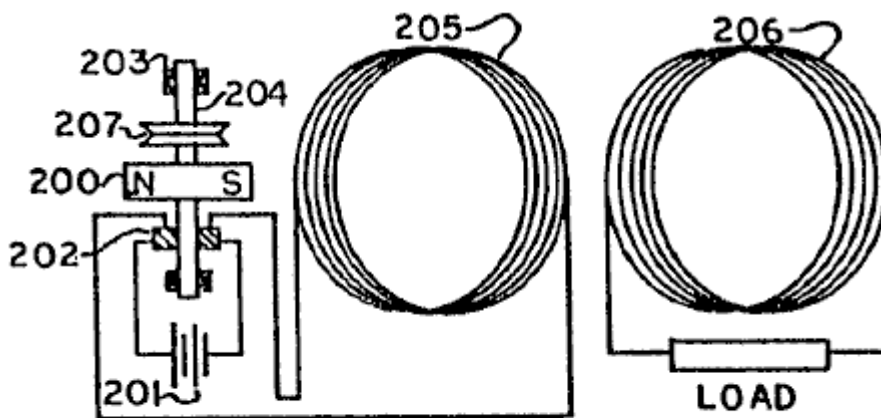

FIG 5

In the prototypes a very small battery **201**, for example, size "N", of 1.5 volts is used. When the circuit is completed, the battery **201** converts an immeasurable amount of its mass into electrical current (gyroscopic particles moving at the speed of light) which goes out through the commutator and brushes **202**, and then enters magnetic producing conductor coil **205** made, for example, from insulated 14-gauge or 15-gauge copper wire, with the total weight of the coil **205** being for example seventy to ninety pounds. This causes the atoms of coil **205** to align extremely fast then releasing some of their electromagnetic make-up (gyroscopic particles) in the form of a magnetic field. This field then interacts with the gyroscopic particles making up the magnetic field coming from the atoms of the material of the permanent magnet **200**.

This causes magnet **200** to attempt to align its magnetic field movement with the magnetic field movement coming from the atoms of coil **205**, resulting in rotation of magnet **200** and the shaft **204** to which it is attached. This then changes the position of the commutator and brushes **202** relative to each other's initial positions, which then causes the electric current coming from battery **201** to be going in the opposite direction into coil **205**, causing the

atoms of coil 205 to extremely quickly reverse their alignment and the polarity of their magnetic field which they are emitting. The reversed field then interacts again with the magnetic field of permanent magnet 200, causing it to further rotate.

This process is then continuously repeated, producing continuous rotation of the shaft 204 which can be used as a source of motive power in many different ways. A power belt wheel 207 for example using a continuous "V" belt is illustrated as a general representation of this motive power source for producing useful, obvious work. In a prototype test run with a small 1.5 volt, type "N" battery, the shaft 204 and the magnet 200 - rotated at a high speed for approximately twelve hours before running down. By improving the particular design features of the prototype and by using longer lasting batteries, the rotation time of the shaft 204 can be greatly increased to a theoretical point approaching "perpetual" for all practical purposes. At the same time the alternating magnetic field produced by the coil 205 induces into coil 206 electrical induction, which then causes coil 206 to produce an alternating current across its "load," which current can be made to exceed the conventional output of the battery 201. The battery source 201 can be replaced when needed.

It is very important to understand that, the longer the length of the conducting wire in coil 205, the stronger will be the magnetic field produced and the less electric current that will complete the circuit and get back into the battery and destroy the mechanical source of the electrical current. This effect can be increased further by increasing the diameter of the conducting wire in coil 205 and then greatly increasing its length still further in the coil.

Reason: The gyroscopic particles making up the electric current interact with the atoms of coil 205. The more atoms in coil 205, relative to its length, the longer it takes the gyroparticles of the electric current to influence them and exit from the other end of the coil. It is then easily seen that if the direction of the current flowing into coil 205 is then reversed, this then further increases the lag time. Reason: The gyroscopic particles have inertia and are believed to be moving at the speed of light and they are interacting with the gyroscopic particles making up the atoms of the conducting coil 205. These atoms also have inertia, and when the direction of current in coil 205 is reversed, the incoming current then collides with the current already in coil 205 going in the opposite direction.

This causes a brief hesitation during the time the current already in the coil is being forced to reverse its direction, thereby then reversing the direction of the atoms within coil 205 which have already been influenced to become aligned. This causes a constant force throughout the circuit, but does not allow very much current to get back into the battery 201 to destroy the mechanical means which initiated the release of electric current in the first place.

Therefore, it should be further understood that, the faster the current direction reverses into the coil 205, the more efficiently the matter of battery 201 is converted into 2 pure electrical energy ($E=MC^2$), without destruction of the mechanical situation that initiates the electrical current release.

It is also important to understand that, the stronger the magnetic field coming from the mass of magnet 200, the greater will be its rotational speed. Additionally, the greater the magnetic field coming from the mass of coil 205, the greater will be the rotational speed of magnet 200, and, up to a point, the greater the electric current input from battery 201, the greater the rotational speed of magnet 200.

Reason: the greater the electric current flow into coil 205, the greater will be the percentage of the atoms making up coil 205 that are aligned. This probably has the same relationship as does achieving atom alignment in conventional magnetic materials. Once complete atom alignment is reached in coil 205, no amount of current will cause those atoms to increase the strength of the magnetic field emitting from those atoms.

Therefore, it should be clear that, for a given input of electric current from battery 201, the most efficient design is one in which the most atoms of coil 205 are influenced to atom alignment by that given electric current, which means increasing the diameter and the length of the conducting wire of coil 205 to the point that the strength of the magnetic field produced is sufficient to cause rotation of the magnet 200 to a speed that allows none or at least very little of the electric current which initially comes from the battery 201 to complete the circuit and get back into battery 201 and destroy or reduce the mechanical effect which induced the conversion of the matter of battery 201 in electric current in the first place. Again this desired effect can be increased by increasing the strength of the magnetic field given off by the atoms of the permanent magnet 200.

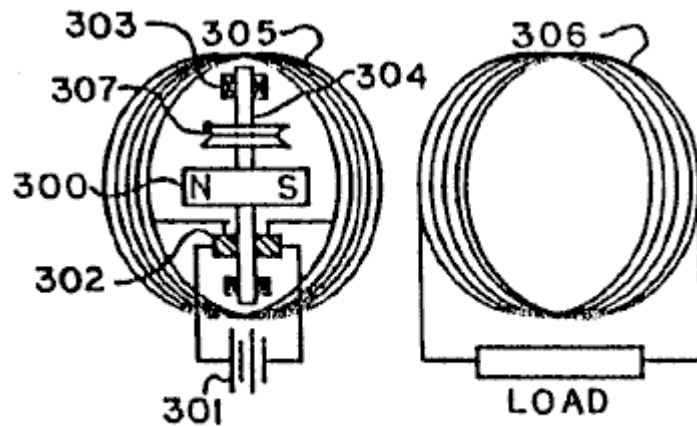

FIG 6

In the second prototype embodiment of **Fig.6**, the structure and operation of the prototype is substantially identical to that of **Fig.5** with the major exception being that the magnet **300**/shaft **304** elements (and related sub-elements **302**, **303** and **307**) are positioned inside of and within the core of the primary coil **305**, as compared to the placement of the magnet **200**/shaft **204** elements next to and along side of the coil **205** of **Fig.5**. Therefore, for brevity, a detailed description of the elements of **Fig.6** will not be repeated, but it is noted that the corresponding and analogous elements and sub-elements are similarly numbered in **Fig.5** and **Fig.6**.

It is also important to again stress the fact that the prototype designs shown are presented simply to prove the correctness of the invention, and it should be clear that the invention can be made extremely more efficient by utilising all of the magnetic field produced by coil **205** and designing the magnet **200** of a shape and strength that efficiently interacts with the majority of the magnetic fields from coil **205**. The illustrated prototypes is relatively highly inefficient in this regard, but even so, the results of the invention itself greatly exceed the prior art as to use of electric current from whatever source and interaction with an electric motor or whatever work was conventionally performed.

The applicant feels it is very important to again stress, in building many varying designs of this invention, consideration must be given to the fact that the Energy in the field of force of any type magnet is the Energy that makes up the Atoms of the material from which it comes! This Energy is a real Entity with, it is believed, a gyroscopic action. It is literally Einstein's Equation of $E=MC^2$ and it is believed that this Energy moves at the speed of light and makes up all Matter. And that this Energy has a constant pressure effect back to the Atoms of the material from which it came, similar to hydraulic pressure. This effect is additionally more fully understood by stating the following results obtained from experimentation by the applicant in the process of this invention.

a) When the system is initially attached to a 1.5 volt size N Battery **201** or **301** and the magnet **200** or **300** and related rotation entities are placed close to or in the centre of coil **205** or **305**, the following results are observed:

If the electric current produced in coil **206** (**306**) is then fed back into coil **205** (**305**) in accordance with proper polarity, the rotation speed of magnet **200** or **300** will then accelerate. If fed back into coil **205** (**305**) in wrong polarity, the rotation speed of magnet **200** (**300**) will slow down.

This proves that the total force from coil **205** (**305**) interacting with the magnet **200** (**300**) is greater when the electrical energy from coil **206**(**306**) is fed back into coil **205** (**305**), then when only the initial electric energy from battery **201** (**301**) is fed into coil **205** (**305**)! When two or three batteries are electrically connected together in series, so as to create for example three or four and a half volts of electrical input, this effect is multiplied. Remember, up to a point, the greater the electrical input, the greater the percentage of atom alignment within coil **205** (**305**).

This further proves that the electric current produced in coil **206** (**306**) is a result of the gyroscopic particles of Energy released from the magnetic fields which came from the Electromagnetic make-up of the atoms of coil **205** (**305**), and is not part of the initial Electrical Energy released from the atoms making up the materials of battery **201** (**301**)! The coil **206** (**306**) can be taken out of the system, or its electrical current fed away from the system, and the rotational speed of the magnet **200** (**300**) will not observably change. However, the rotational speed of magnet **200** (**300**) will noticeably change when the electric current from coil **206** (**306**) is fed back into coil **205** (**305**)!

Now a different result:

b) When the electric current from battery **201 (301)** becomes weaker to the point that the magnetic field coming from coil **205 (305)** has weakened and shrunk allowing the magnetic field of the rotating magnet **200 (300)** to expand and then noticeably induce electric current into coil **206 (306)** and into coil **205 (305)**, then reverse results are observed. When the magnetic field from the coil **205 (305)** is large, then the magnetic field from magnet **200 (300)** is retained! If coil **206 (306)** is then short circuited, the rotation of magnet **200 (300)** will noticeably slow down.

If electric current from coil **206 (306)** is fed back into coil **205 (305)** in wrong polarity, the rotation of the magnet **200 (300)** will stop. If fed back into coil **205 (305)** in correct polarity, the rotation of the magnet **200 (300)** will slow down. At that point, the rotation of the magnet **200 (300)** will not accelerate, no matter how connected!

These results show that, at this time, the magnetic field from magnet **200 (300)** noticeably induces a current in coils **206 (306)** and **205 (305)** which opposes the rotation of the magnet **200 (300)**. This effect has already been mechanically explained, and it has been shown that Lenz's Law was simply an observation of that mechanical explanation. These results further demonstrate that the expanding and collapsing magnetic fields from coil **205 (305)** and **206 (306)** do not noticeably effect each other detrimentally.

Because the resulting magnetic fields from all the coils are the results of fluctuating atom alignment within the coils! Remember, the gyroscopic energy particles making up the magnetic fields have a hydraulic pressure effect back to the atoms from which they came. Also remember that the atoms making up the material of the permanent magnet **200 (300)** are stationary as to atom alignment direction! Therefore, the pressure effect resulting from an opposing field which the magnet **200 (300)** induced, is immediate. As is Hydraulic Pressure.

However, the magnetic field emitted from the atoms of coil **205 (305)** relative to induction into the atoms of coil **206 (306)** are fluctuating and out of step, so to speak, and therefore, in harmony with each other. The pressure effect from the induction of coil **205 (305)** into coil **206 (306)** is an action and reaction effect which reinforces the flipping action of the atoms of coil **205 (305)** and back into the atoms of coil **206 (306)**.

This action is again seen when the invention is hooked into one-hundred-fifteen volt alternating current, and battery **201 (301)** is not used. The magnet **200 (300)** will not rotate even though the magnetic field from coil **205 (305)** is strong and is alternating. Reason: The fluctuating magnetic field is so fast, that the inertia mass of magnet **200 (300)** can not get started in one direction before the magnetic field from coil **205 (306)** has reversed, thereby, causing magnet **200 (300)** to vibrate only microscopically at sixty cycles per second. And, if a sixty watt bulb is hooked into the system of coil **205 (306)**, it will only light dimly. And there is a lag time of two to three seconds before it lights even dimly.

If then coil **206 (306)** is hooked to a meter, there is a reading of forty-nine volts, and if the meter is replaced by another sixty watt bulb it will light only extremely dimly. However, the sixty watt bulb hooked to coil **205 (305)** will now become noticeably brighter! This again shows that the action and reaction results of the atoms of the coils are not noticeably detrimental to each other. Because of the lag time (out of step, so to speak), resulting in reinforcing the flipping atom alignment of the coils.

From this further explanation of the invention it is seen that desirable results may be obtained by the following:

For example, in **Fig.6** the magnet **300** may be of a design and/or be located at a distance from the inside diameter of coil **305** and coil **306**, whereby the majority of the magnetic field from the magnet **300** does not cut the conducting loops of coil **305** or **306**. Yet the alternating magnetic field produced by coil **305** should efficiently have the majority of its gyroscopic particles interacting with the majority of the gyroscopic particles making up the magnetic field of the permanent magnet **300**, but not directly reacting with the atoms making up coil **305**, or magnet **300**!

When the magnetic lines of force of the magnet **200 (300)** cross at right angles with the conducting wires of coil **205 (305)**, **206 (306)**, a braking action is incurred. It should be noted that, as the inner diameter of coil **205 (305)** increases, the percentage of time of braking effect decreases.

Along this same line of instruction, the commutator segments **202 (302)** can be made of a large diameter and the area of brushes made small, whereby, when the brushes cross over the gaps in the commutator segments, there will be no short circuit at any time directly back to the battery **201 (301)**.

By combining the slip rings and brushes (the slip rings can be made of a small diameter) to the side or sides of the brushes and commutator segments **202 (302)**, then battery **201 (301)** does not have to rotate with magnet **200 (300)**.

The 14-gauge and 15-gauge insulated copper wire weighing seventy and ninety pounds respectively (31.5 kilograms and 40.5 kilograms) used for the motor coil **205 (305)** and the generator coil **206 (306)**, respectively, in the first hand-made prototypes of the embodiments of **Fig.5** and **Fig.6**, for demonstration purposes only, come in standard buckets of varying weights from wholesale outlets.

It was then wound in coils as shown, and, as taught, the more conducting wire used, the better the results. The magnets **200** and **300** were each initially about a 2.5 inch (6.25 centimetre) cube and can be any size and strength desired.

In a further, rough, hand-built, demonstration, working prototype of the invention of the type illustrated in **Fig.6**, the primary or motor coil **305** was made of 5-gauge copper wire in a single, continuous wire, weighing approximately 4,100 pounds (1,845 kilograms) with a coil loop diameter of 4.5 feet (135 centimetres), while the secondary or generator coil **306** was made of 24-gauge copper wire in a single continuous wire weighing approximately 300 pounds (135 kilograms) with the same, approximate coil loop diameter of 4.5 feet (135 centimetres), with both coils **305, 306** coincidentally forming a cylinder of approximately 30 inches (75 centimetres) in length. The coils **305, 306** were built around a cylindrical, fiberglass core body of approximately 200 pounds (90 kilograms) having a vertical, longitudinal centre-line axis.

The rotating magnet **300** was made up of six, separate, parallel cylindrical magnetic columns spaced and disposed about the periphery of a hollow cylindrical fiberglass surface of approximately twenty inch (fifty centimetres) in diameter. Each column was 30 inches (75 cm.) long and was composed of a stack of 70, individual ceramic ring magnets in disc form as made by Jobmaster Magnets of Randallstown, Maryland, 21133, U.S.A. Each disc had a thickness of seven-sixteenths of an inch (1.09375 centimetres), an inner diameter of 1 inch (2.5 cm.) and an outer diameter of 4 inches (10 cm.). The discs were stacked and secured together in 4 inch (10 cm.) diameter fiberglass tubes longitudinally mounted on the inner surface of the twenty inch (fifty cm.) diameter fiberglass cylinder.

The composite magnet **300** had a total weight of approximately 400 pounds (180 kilograms) and a total length of 30 inches (75 cm.) and an approximate diameter of 20 inches (50 cm.).

The magnet **300** was mounted for rotation on a horizontal shaft **304** extending across the hollow core of the coils **305, 306** crossing through the centre point of the longitudinal centre-line of the cylinder and orthogonally to the longitudinal centre-line of the magnet **300** for rotation within the open centre area of the cylindrically disposed coils **305, 306** with the longitudinal centre-lines of the coils being vertically disposed.

With a D.C. battery source **301** of two 12 volt lantern batteries and seventeen 6 volt lantern batteries all in series (totalling 126 volts), a measured voltage of 126 volts and a measured current of 99 milliamps in the primary coil **305** were noted. Concurrently a voltage reading of 640 volts and an amperage measurement in excess of 20 milliamps were noted in the secondary or generating coil **306**, with the magnet **300** rotating at a speed of 120 revolutions per minute (rpm). Thus the system was outputting and producing in the generating coil **306** usable electrical energy in excess of 102% of that being inputted in the motor coil **305**! This excess useful electrical energy, of course, is in addition to the further useful mechanical energy available at the exemplary drive take-off **307** on the rotating shaft **304**, on which the 400 pound, 30 inch long magnet **300** was rotating at 120 rpm!

Thus the invention, by utilising the energy of the gyroscopic particles in the magnetic field, produces a greater energy output than the energy input into the system, thus producing results beyond presently accepted scientific teachings of the world.

This prototype achieves exactly what has already been described in great detail in applicant's prior patent applications. There was simply used in this prototype a stronger magnet and a larger diameter conducting wire of great length, that has a considerably greater number of atoms aligned when current is put into the system, and used a greater number of atoms in the generator coil of fine diameter conducting wire.

While the results of the energy released from this particular prototype is highly impressive to others, the applicant still has only scratched the surface of the energy that can be released using the principles of the present invention.

Again, as has already been stressed, the most efficient design, is one in which the least amount of input of current causes the greatest amount of atom alignment.

These data do not constitute any departure from applicant's previous work, but is only to further document that which has already been stressed in the prior patent applications.

Varying the D.C. voltage for the battery source **301** shows that obvious efficiency will continue to rise as the voltage input goes up! Also, the leverage factor advantage of the invention, combined with the inertia of the 400 pound magnet **300** rotating at 120 rpm (even while causing the electrical generator to put out over 100% of energy input) proves the invention to be greatly over 100% efficient even at this slow rpm.

It is contemplated that the next prototype will use super-conducting type material for the coil **305** with a magnet **300** having a magnetic field strength comparable to that of cryogenic-type magnet relative to percentage of atom alignment or size. This will result in the size of the device being much smaller and yet with the available work output being much greater than the prototype just described. Reason: The most efficient type design is one whereby the least amount of current input into the motor coil produces the greatest atom alignment of said motor coil and having rotatable magnet also comparable in strength, relative to size.

The invention can be made without using the coil **206 (306)** and producing just useful mechanical energy.

Coil **206 (306)** can be merged or wound with coil **205 (305)**.

The magnet **200 (300)** can be an electromagnet, a permanent magnet, a cryogenic magnet or any magnet.

The design of magnet **200 (300)** can create a strong but retained magnetic field.

The design of coil **205 (305)** can be used to further retain the magnetic field of magnet **200 (300)**.

Alternating current (A.C.) can be used in place of the direct current (D.C.) battery **201 (301)**, if the magnet **200 (300)** is designed accordingly.

The coils **205 (305)** and **206 (306)** may be made up of several coils rather than a single coil.

The magnet **200 (300)** may be made up of several individual magnets rather than from just a single magnet.

From the foregoing it should be understood that, unlike the teachings of the prior art, the following is desired in the design of the coil **205/305** under the principles of the present invention:

- a) Current initially flowing into and through the coil should be small compared to the energy output of the system;
- b) A relatively large diameter wire or its equivalent is used for the coil;
- c) A relatively large number of coil loops or coils is used;
- d) A relative long, continuous length of coil wire or its equivalent is used; and
- e) The greatest magnetism for a given mass of the magnet **200/300** is desired but may be designed so that the magnetic lines of force will not cut the coils at a right angle.

The present invention applies to any mechanical device which is operated by electrical energy. In accordance with the principles of the present invention, the mechanical device should be designed wherein the electric current as much as is feasible cannot get back to its source, but the circuit is completed whereby the "pressure force" is constant throughout the system.

What has been invented, built and disclosed is an invention of immense importance to the well-being of the entire world. There will be many devices built from what has been shown and taught. It should now be known that all matter is made up of electromagnetic energy and that there are many mechanical ways to release this energy, as has been stated throughout the five prior, related patent applications hereof and the Disclosure Document. All of these future developments will be as a result of the present invention which - releases energy above and beyond conventional energy release mechanisms, prior to this invention.

Some of the basic approaches of the invention are outlined below:

1. Any device which utilises a means by which the electric current (electromagnetic energy) is retained within a member or members outside of the source of said original electric current and then, as a result thereof, is capable of producing a continuous electromagnetic motion or current if so desired beyond present scientific teachings.
2. Any device which releases the electromagnetic energy make up of matter to such an impressive degree as does this invention that it defies several of the present accepted laws of physics and electrical engineering as of this time.
3. That the energy release is noticeably higher and in some cases more controllable than the conventional means of energy release of this time.

Because many varying and different embodiments may be made within the scope of the inventive concept taught here, and because many modifications may be made in the embodiments detailed here in accordance with the descriptive requirements of the law, it is to be understood that the details given above are to be interpreted as illustrative and not in any limiting sense.

CLAIMS

1. A usable energy generation system, comprising:

usable energy output means for making available for use the usable energy generated in the system; and usable energy generation means associated with said output means and designed to take into account the reaction to a force of the gyroscopic type energy particles and to utilise the gyroscopic type energy particles moving in a magnetic field for producing usable energy of an amount greater than the amount of energy input.

2. The system of Claim 1, wherein said generation means includes structural means for placing a force at an angle to the gyroscopic particles causing the particles to follow paths having a net directional effect, producing electric current flow.

3. The system of Claim 2, wherein said structural means comprises magnetic means and a closed housing associated therewith containing a fluid in the magnetic field produced by said magnetic means, said fluid becoming charged as a result of its interaction with the gyroscopic type energy particles making up said magnetic field.

4. The system of Claim 3, wherein said magnetic means is a series of aligned magnets positioned centrally within said housing but electrically insulated therefrom.

5. The system of Claim 3, wherein there is included a further, keeper housing completely surrounding said closed housing and electrically insulated therefrom, said keeper housing tending to keep and concentrate the magnetic field produced by said magnetic fields within it.

6. The system of Claim 3, wherein said output means includes a network of metallic surfaces immersed in said fluid to pick up the electrical charges on said fluid.

7. The system of Claim 2, wherein said structural means comprises a member having its atoms aligned to produce a net magnetic field which is at least substantially contained within the surface boundaries of said member.

8. The system of Claim 7, wherein said member is positioned in operative association to at least one magnet, and said member and said magnet are held static with respect to one another.

9. The system of Claim 1, wherein:

The usable energy generation system comprises an electrical energy generation system; said usable energy output means comprises an electrical power output means; and said usable energy generation means comprises electrical energy generation means.

10. The system of Claim 1, wherein:

the usable energy generation system comprises usable motion generation system; said usable energy output means comprises usable motion output means; and said usable energy generation means comprises usable motion generation means.

11. The system of Claim 1, wherein said generation means includes:

a magnetic device;

a source of electrical energy;

complete electrical circuit means between said magnetic device and said source of electrical energy for producing an alternating electrical current potential; and

current retarding means for retarding the flow of current through said device back to said source to the greatest extent practical, producing a relatively small and preferably negligible current flow through said source.

12. The system of Claim 11, wherein said magnetic device includes at least one relatively large coil of wire having a relatively large number of turns of wire of a relatively large diameter and a relatively great length.

13. The method of producing usable energy utilising a magnetic field system, comprising the following steps:

a. providing a structure interacting with a magnetic field; and

- b. arranging said structure to utilise the energy of the gyroscopic type particles in the magnetic field to generate an electrical current in said structure, or usable motion from said system, or both, and results in producing a greater energy output than energy input into the system.
- 14.** The method of Claim 13, wherein there is included in step "b" the further step of arranging said structure to place a force at an angle to the gyroscopic particles cause the particles to follow paths having a net directional effect, producing electric current flow, without any normal, visible movement taking place in the system.
- 15.** The method of increasing the availability of usable electrical energy or usable motion, or both, comprising the steps of:
- providing a magnetic device for producing usable electrical energy or usable motion, which device includes a material through which electrical current can interact producing a magnetic field which interacts with a separate mass having a magnetic field, and further providing a source of electrical energy such as for example a battery, generator, or any other;
 - providing a complete electrical circuit between said magnetic device and said source of electrical energy and producing from said source to said device an alternating electrical current potential; and
 - retarding the flow of current through said device back to said source to the greatest extent practical, producing a relatively small and preferably negligible current flow through said source and resulting in electrical energy output, or usable motion output, being a greater energy output than energy input into the device.
- 16.** The method of Claim 15, wherein step "c" is achieved at least in part by the step of providing in said device a relatively large coil or coils of wire having a relatively large number of turns of wire of a relatively large diameter and a relatively great length.
- 17.** The method of Claim 15, wherein step "c" is achieved at least in part by the step of utilising a means by which the electric current is retained within at least one member outside of the source of said original electric current and then, as a result thereof, is capable of producing a continuous electromagnetic motion or current.
- 18.** The method of claim 15, wherein there is included the step of providing a separate magnetic source positioned so that its magnetic lines of force avoid significantly cutting the material through which the electrical energy flows avoiding a braking effect which would retard the desired motion of said magnetic source.
- 19.** The method of Claim 15, wherein step "a" is achieved by said material being a super conducting material and said separate magnetic mass is at least equivalent to a cryogenic magnet.
- 20.** The method of Claim 15, wherein step "a" is achieved by the step of having said material a conducting material and said separate magnetic mass of any desired configuration or strength or type.
- 21.** The method of increasing the availability of usable electrical energy, or usable motion, or both, comprising the steps of:
- providing a magnetic device which has a material mass into which an electrical current is introduced, by any desired means, which results in causing pertinent atom alignment, within said material mass, thereby releasing some of the electromagnetic energy making up the atoms of said material mass, in the form of a magnetic field, which then causes the gyroscopic type energy particles of said magnetic field to then interact with the gyroscopic type energy particles making up a magnetic field coming from the atoms of a different material mass; and
 - having the magnetic device then cause a release of electrical current or usable motion or both through at least one power outlet and resulting in producing a greater energy output than energy input into the device.
- 22.** The method of Claim 21, wherein the material mass or masses are made of a material or substance that allows for extremely fast atom alignment, without the delay, or conventional degree of hysteresis losses normally associated with conventional iron atom alignment.
- 23.** A device which increases the availability of usable electrical energy or usable motion, or both, by causing the atoms of a material or materials to release some of their magnetic energy makeup in the form of a magnetic field, consisting of gyroscopic type energy particles which make up the atoms of the material from which the magnetic field comes; and
- a properly designed mechanism, or power output arrangement being place to utilise the energy of said gyroscopic type energy particles, causing a release of energy output greater than energy input without producing radioactive material.
- 24.** A device which increases the availability of usable electrical energy or usable motion, or both, from a given mass or masses by a device causing a controlled release of, or reaction to, the gyroscopic type energy

particles making up or coming from the atoms of the mass or masses, which in turn, by any properly designed system, causes an energy output greater than the energy input.

25. A system including an energy generator, motor, etc.

of any design or mechanism that takes into account- the reaction to a force of the gyroscopic type energy particles moving in a magnetic field at tremendous speeds which releases greater output than energy input.

26. The system of Claim 25, wherein a small input of electrical current into the mechanism causes extremely quick and high atom alignment, resulting from using a super conducting material, thereby creating a powerful magnetic field, whereby its gyroscopic type energy particles then interact with the gyroscopic type energy particles coming from a second powerful magnetic field and results in producing a greater output of energy than input of energy into the mechanism.

27. The system of Claim 25, wherein a structure is arranged, whereby, there is, or will be, a pressure, or force, exerted on or in said structure, thereby causing the atoms of said structure to react to said pressure or force, and as a result take a pertinent atom alignment direction that results in said atoms of said structure then causing the gyroscopic type energy particles moving in the magnetic field to be generally deflected in the same direction through said structure, which results in usable electric current flow, producing a greater energy output, than energy input into the system.

28. The system of Claim 25, wherein a rotary magnetic mass is designed to react to a reversing magnetic field of another mass, and said reversing magnetic field can not reverse any faster than the atoms of said other mass can flip and realign; said rotary magnet mass being made as long as is practical to adjust to this requirement, wherein the distance of the arc of circle travelled by the ends of said rotary magnet mass is great; great leverage from said reversible magnetic field of other mass being applied to said rotary magnet, and in addition the increased distance of arc travelled by the ends of rotary magnet before the magnetic field of said other mass reverses, greatly increasing the time in which a maximum force is exerted by the gyroscopic type energy particles moving in the magnetic field coming from the maximum number of atoms aligned in said other mass, thereby causing a longer time of acceleration of said rotatable magnet mass before the atoms of said other mass are required to reverse.

29. The method of producing usable energy, comprising the following steps:

- a.** imputing energy into a device from an external source;
- b.** having electrical current flow within said device; and
- c.** utilising the internal electromagnetic energy of at least some of the matter in the device to add to the energy being imputed into the device from the external source to produce useful energy for use outside of the device having an amount greater than the energy being imputed to the device.

FERROELECTRIC CERAMIC DEVICES

This version of the patent has been re-worded in an attempt to make it easier to read and understand. The original can be examined at www.freepatentsonline.com and downloaded without charge. This patent covers several different applications, namely; a high-voltage very high-efficiency solar electric device, a photovoltaic memory device, an optical display device and a high-voltage battery, to name just a few. It should be noted that this patent is assigned to the US Army. In my opinion, that lends weight and credibility to this patent. It is claimed that a one centimetre square piece of this material can produce 1,500 volts as opposed to less than one volt using conventional solar cell materials.

ABSTRACT

A method and apparatus is disclosed by which high voltage and current can be produced by a polycrystalline ferroelectric ceramic material in response to incident light. Numerous applications of the ferroelectric ceramic material taking advantage of such properties thereof are further disclosed. The polycrystalline ferroelectric ceramic material is initially poled by the application of a pulse of voltage of predetermined magnitude and direction. After being poled in such fashion, light shining on the various surfaces of the ferroelectric ceramic material will generate a consistent high voltage between the surfaces of the ferroelectric ceramic material. If electrodes are attached to the material, then a current will be generated and a load can then be powered by it. Importantly, the magnitude of the voltage produced by the light is directly proportional to the remanent polarisation of the ferroelectric ceramic material, and is further directly proportional to the length of the material, the polarity of the high voltage being dependent upon the polarity of the remanent polarisation and being capable of being reversed when the remanent polarisation is reversed. The open circuit voltages produced by the ferroelectric ceramic material are orders of magnitude higher than those which typically have been produced in the prior-art through the utilisation of standard photovoltaic materials.

DESCRIPTION

BACKGROUND OF THE INVENTION

This invention generally relates to solid state devices exhibiting photovoltaic effects and is particularly directed to the provision of a device consisting of a class of polycrystalline ferroelectric ceramic materials which have been discovered to produce voltages upon the application of light. These voltages are many orders of magnitude higher than voltages typically produced by conventional photovoltaic materials.

Initially, and as background, the instant inventive apparatus and techniques to be discussed below are to be clearly distinguished from the photovoltaic effect now known in the prior-art in that the mechanism for the effect to be discussed herein appears to be unique and different from photovoltaic mechanisms previously described.

SUMMARY OF THE INVENTION

It is the primary objective of the instant invention to provide a device and technique by which extremely high voltage can be generated utilising a solid state polycrystalline class of materials upon the application to such materials of incident light, the voltage generated exhibiting properties entirely unlike the well-known photovoltaic effect of the prior art and of orders of magnitude higher than voltages previously obtainable.

Another equally important objective of the instant invention is the provision of apparatus utilising ferroelectric ceramic materials of the type to be described below, such apparatus taking advantage of the unique properties as discovered to be existent in the class of materials to which the instant invention relates.

These broad objectives, as well as others which will become apparent as the following description proceeds, are implemented by the subject invention which utilises at its heart a class of materials known as ferroelectric

ceramics, and which take advantage of the unique photovoltaic properties discovered to be existent in such class of materials.

Specifically, by illuminating the surfaces of these materials, a steady voltage results across conducting electrodes placed in contact therewith. Currents can then be drawn through loads placed across these electrodes. It has been discovered that an arrangement of an initially polarised ceramic material with electrodes attached thereto as is shown in **Fig.1** of the application drawings produces steady high voltages from a steady illuminating source such as the sun, an incandescent bulb, a fluorescent tube, etc. and that the magnitude of these voltages is high and directly proportional to the length, l of the sheet of material provided. In **Fig.1**, the shaded area represents an electrode, and P_r is the remanent polarisation. In another basic arrangement of the invention, light enters through transparent electrodes and the material is poled in the direction of the light, and the photo-emf up to a certain limiting thickness is proportional to the thickness of the slab.

It has further been discovered that the magnitude of the photo-voltages produced is directly proportional to the remanent polarisation of the material. The polarity of the photo-voltage is dependent on the polarity of the remanent polarisation and reverses when the remanent polarisation is reversed. The magnitude of the voltages that are produced can also be varied by varying the sizes of the grains of which the ceramic is composed, the voltage having a generally proportional relation to the number of grains per unit length. Grain size can be controlled by well-known fabrication techniques involving compositional additives and firing rates, which techniques do not form a part of the present disclosure.

When illuminated at intensity levels such as that produced by direct sunlight or at lesser levels such as that produced by a fluorescent lamp, the materials will behave as voltage sources in series with a high output resistance. The output resistance will decrease as the intensity of illumination increases and also varies with wavelength.

The open circuit voltages produced by the materials of the invention are much higher than those that are typical of other photovoltaic materials. These high open circuit photo-voltages have been observed to some extent in virtually all materials examined which can generally be described or classified by the term ferroelectric ceramic, provided that the material was characterised by a net remanent polarisation. Such high photo-voltages are to be expected in virtually all polarised ferroelectric ceramic materials properly doped, the class including thousands of different known materials of this kind with numerous variations possible in each kind. Such variations are produced by additives, varying grain size, and by changing compositional blends, in those formed from mixtures. Any of these are expected to have application as photovoltaic materials.

From the viewpoint of application, the novel photovoltaic effect seen in ferroelectrics in accordance with the teachings herein differs in two important respects from the well known junction photovoltaic effect which is the mechanism in prior-art devices such as solar cells, and photo-diodes.

First, the prior-art junction photo-emf is independent of the length or thickness of the unit and is low, less than one volt. To obtain high voltages, many cells have to be connected in series. The photovoltaic effect in ferroelectrics, on the other hand, can be used to directly produce high voltages. The photo-emf is proportional to length, and the photo-emf per unit length can be very high. For example, the composition $Pb(Zr_{65}Ti_{35})O_3$ with 7% of the lead substituted by lanthanum, when composed of 2-4 microns grains produces, when illuminated as shown in **Fig.1**, 1500 volts for every centimetre of length between the electrodes. A single one cm square unit thus directly produces 1500 volts.

In this case, it is also clear that the voltage per unit length will be further increased by the development of a composition in which the average grain size is further decreased.

These voltages are so high that applications have been contemplated which are alternatives to the devices presently used for the generation of extremely high DC voltages at low currents -- such as belt machines (the Van de Graaf), in which high voltages are produced by mechanically moving electric charges.

Second, and perhaps even more important, is the fact that the direction of the photo-current and photo-voltage can be reversed simply by reversing the direction of its remanent polarisation. The magnitude of these quantities can be changed by changing that of the remanent polarisation, which in turn can be done (for example) by applying the proper polarity electrical voltage (poling voltage) to the same terminals across which the photo-voltages appear. The reversibility and control provided make immediately possible applications to use in computer memories of a new type -- in which information is stored as remanent polarisation and read out as the polarity and magnitude of a photo-current or photo-emf, such typical applications are disclosed here.

Application to the generation of electrical power from solar radiation, for example, to solar battery type devices and to electrical power generating stations operating on the basis of solar to electrical energy conversion also is

possible and contemplated but would require, to be practical, (except in special cases) considerably larger conversion efficiency than has been observed so far in the materials examined. A calculation of theoretical maximum efficiency, however, yields results which are large enough to suggest eventual practical use in this manner. A conversion system based on these high voltage materials would have the particular advantage of producing its electricity directly at high voltage which is advantageous for power transmission purposes.

The mechanism for the discovered effect appears to be unique and different from photovoltaic mechanisms previously described. Description will be provided explaining the mechanism and developing a theory for it. From this, it will be clear that the entire class of polycrystalline ferroelectrics are expected to exhibit high photo-emf's to at least some extent.

BRIEF DESCRIPTION OF THE DRAWINGS

The invention itself will be better understood and further features and advantages of it will become apparent from the following detailed description which makes reference to the drawings, where:

Fig.1 is a schematic diagram illustrating the basic arrangement by which photovoltaic voltages are generated by the application of light to a ferroelectric ceramic material as shown by this invention;

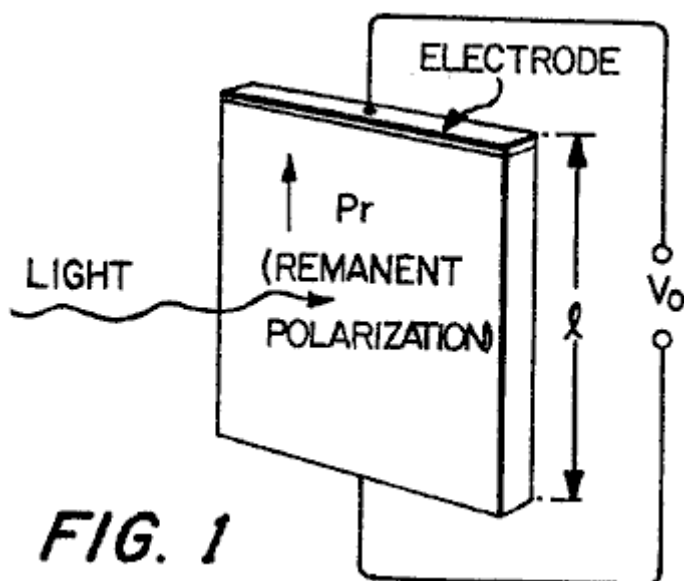

FIG. 1

Fig.2 is an electrical schematic diagram depicting an equivalent circuit to the basic apparatus of **Fig.1**, where **C₀** is the capacitance of the sample measured utilising a capacitance meter connected between the electrodes and **C₁** is the parallel capacitance of a load coupled to the electrodes, and **R₁** is the resistive value of that load;

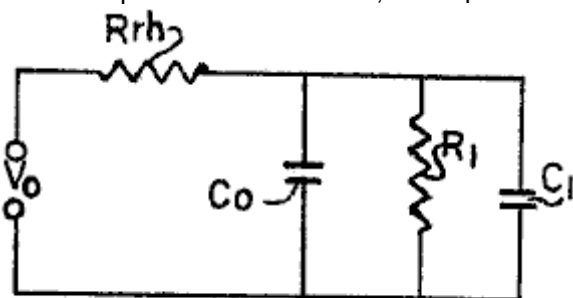

FIG. 2

Fig.3 is a graphical illustration of current vs. applied voltage to an illuminated ferroelectric wafer of the basic form depicted in **Fig.1**;

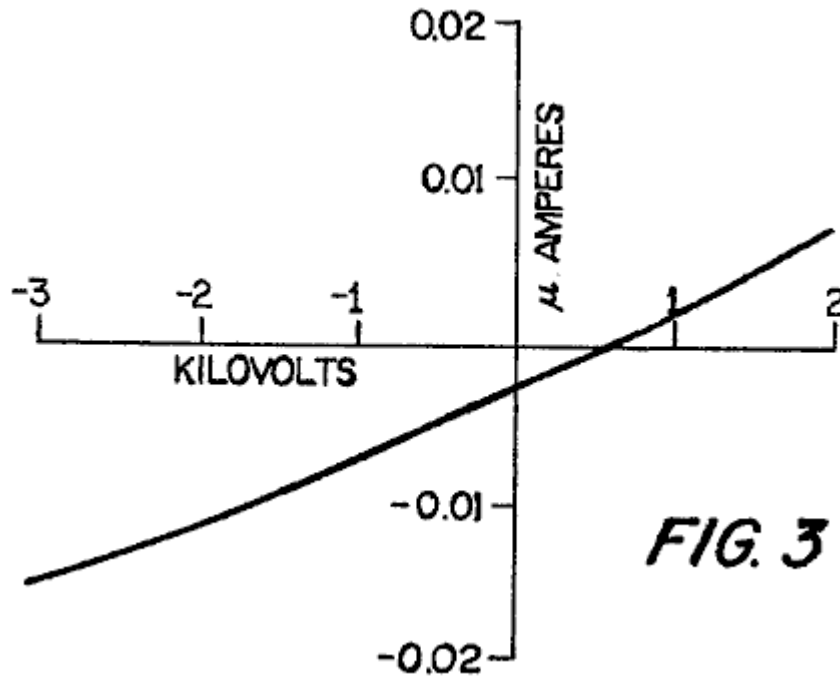

FIG. 3

Fig.4 is a graphical illustration of the photo-emf and photo-current as a function of intensity of illumination, with the particular graphical results being for a solid solution $\text{Pb}(\text{Zr}_{0.53}\text{Ti}_{0.47})\text{O}_3$ with about 1% by weight of Nb_2O_5 added;

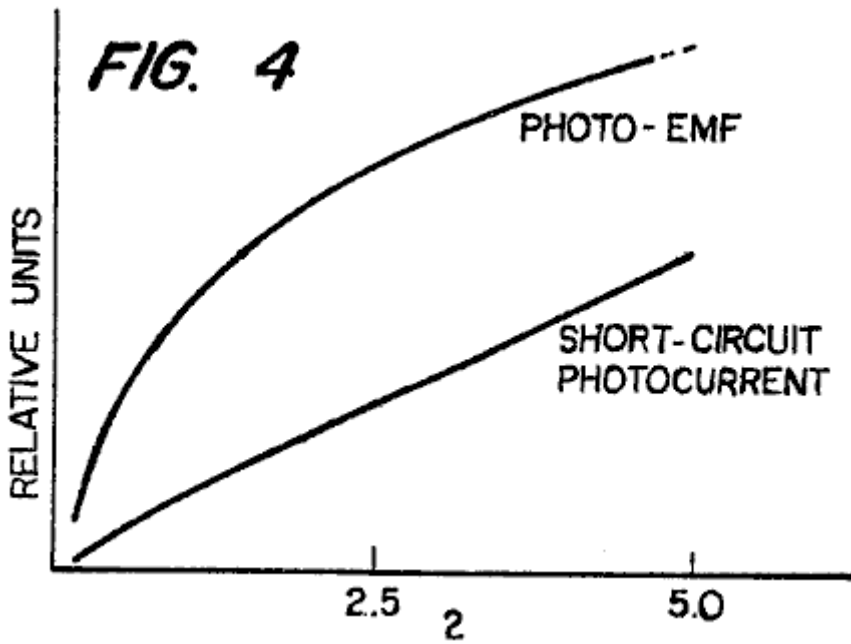

FIG. 4

Fig.5 is a graphical illustration of photo-emf vs. grains per unit length (inverse median grain size) for two different materials;

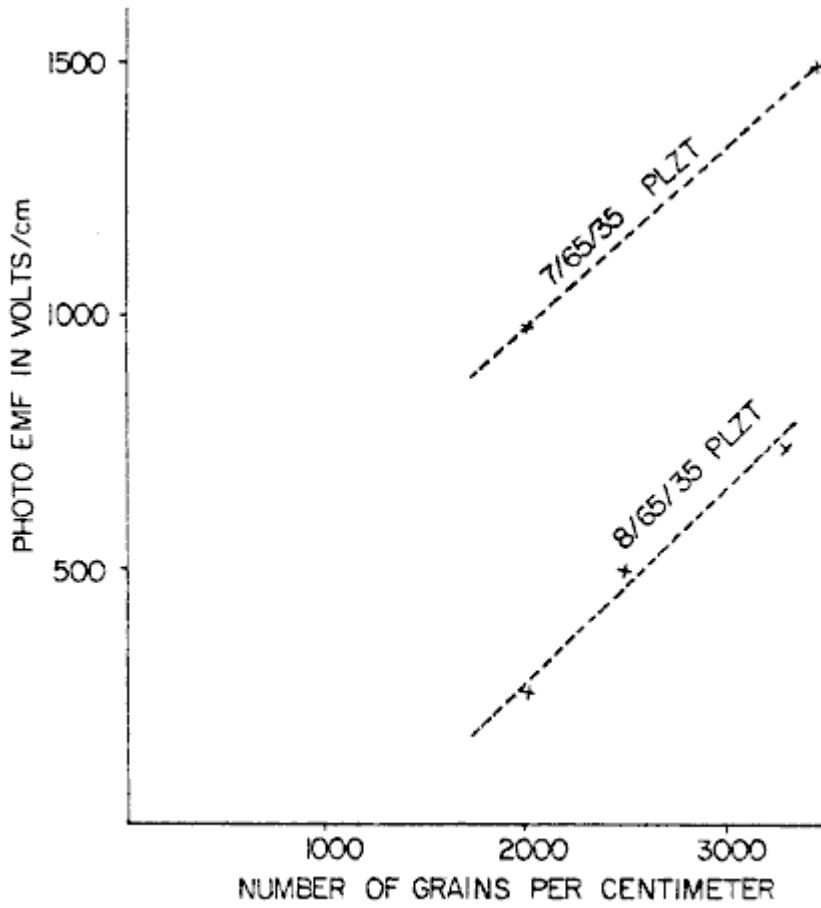

FIG. 5

Fig.6 is a graphical illustration of photo-voltage vs. remanent polarisation for ceramic BaTiO_3 + 5% by weight of CaTiO_3 ;

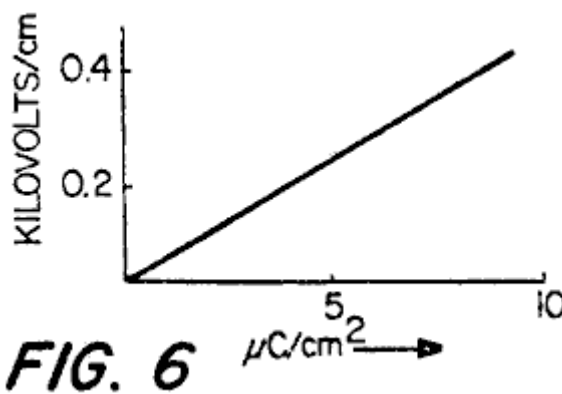

FIG. 6

Fig.7 is a diagram illustrating the short-circuit photo-current as a function of wavelength for the solid solution $\text{Pb}(\text{Zr}_{0.53}\text{Ti}_{0.47})\text{O}_3$;

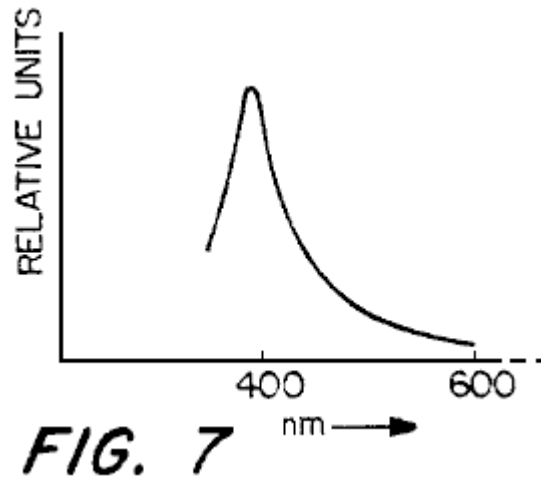

Fig.8 is a diagram illustrating the short circuit photo-current as a function of wave length for ceramic $\text{BaTiO}_3 + 5\%$ by weight of CaTiO_3 ;

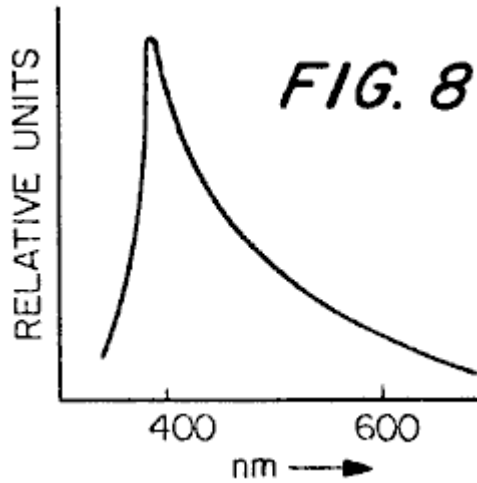

Fig.9 is a diagram illustrating the short-circuit photo-current as a function of wavelength for the solid solution $\text{Pb}(\text{Zr}_{0.65}\text{Ti}_{0.35})\text{O}_3$ with 7% of the lead substituted for by lanthanum;

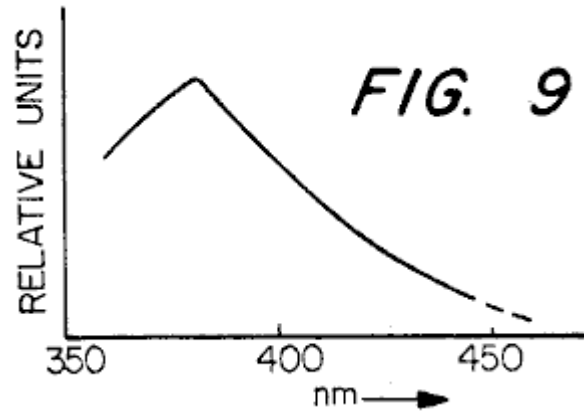

Fig.10 is a diagram illustrating the photo-emf vs. wavelength for the solid solution $\text{Pb}(\text{Zr}_{0.35}\text{Ti}_{0.47})\text{O}_3$ with 1% by weight of Nb_2O_5 added;

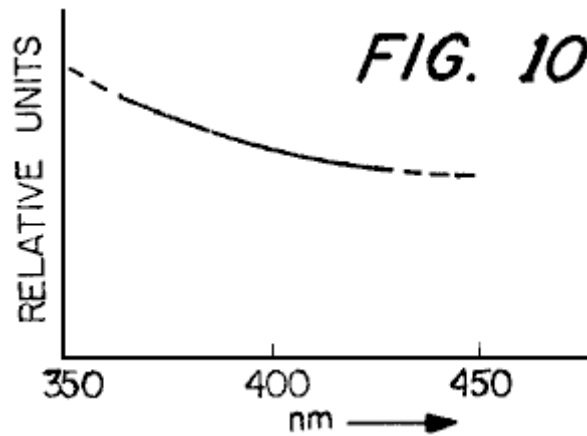

Fig.11 is a diagram illustrating the photo-current divided by intensity vs. cut-off wave length of long wave length cut-off dichroic filters, with the materials being $\text{Pb}(\text{Zr}_{0.53}\text{Ti}_{0.47})\text{O}_3$ with 1% by weight of Nb_2O_5 added and utilising a high-pressure mercury arc as the illumination source;

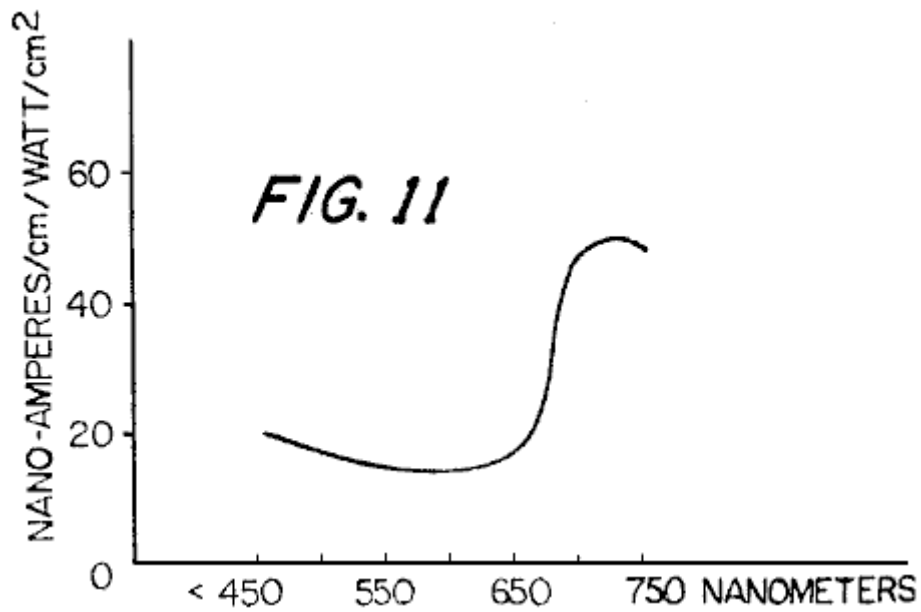

Fig.12 is a diagram illustrating the photo-current divided by intensity vs. cut-off wavelength of short wave length cut-off filters, with the material being $\text{Pb}(\text{Zr}_{0.53}\text{Ti}_{0.47})\text{O}_3$ with 1% by weight of Nb_2O_5 added;

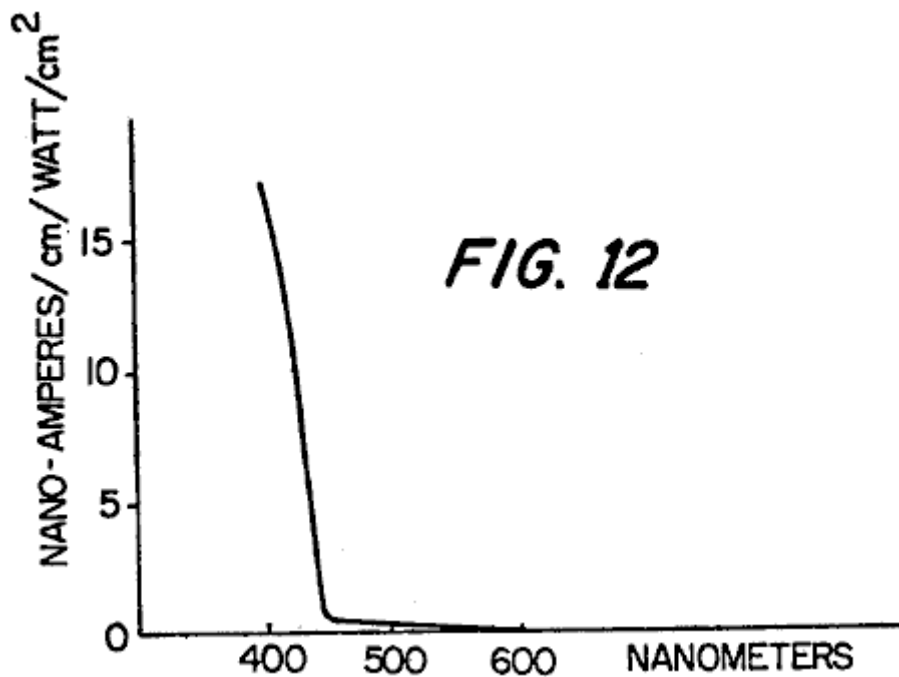

Fig.13, is diagram illustrating the photo-emf vs. wave length of short wavelength cut-off filters, with the material being $\text{Pb}(\text{Zr}_{0.53}\text{Ti}_{0.47})\text{O}_3$ with 1% by weight of Nb_2O_5 added;

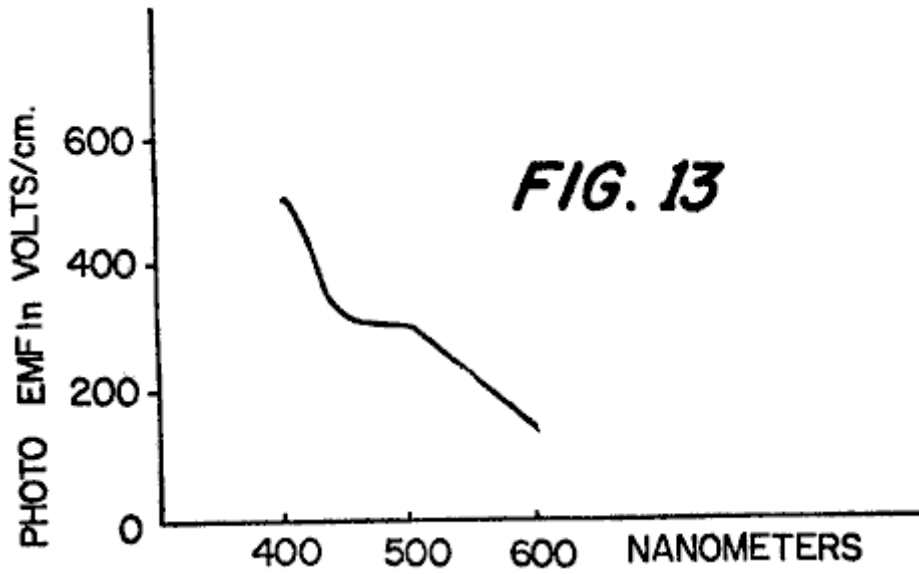

Fig.14 is a pictorial illustration of the manner in which a single crystal produces a photo-emf, with the polarisation P_s being normal to the electrodes, which electrodes are illustrated by the shaded area;

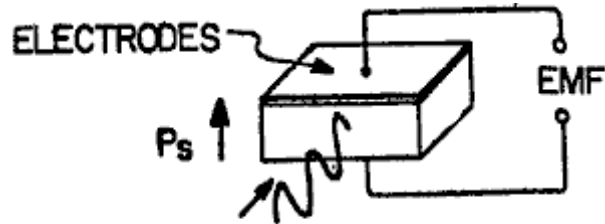

FIG. 14

Fig.15 is a diagram illustrating photo-current vs. wave length of the single crystal BaTiO₃ ;

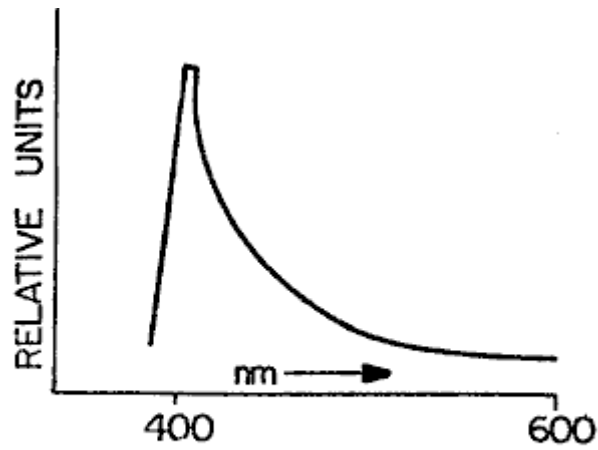

FIG. 15

Fig.16 is a diagram illustrating the photo-voltage vs. temperature for BaTiO₃ +5% by weight of CaTiO₃ ;

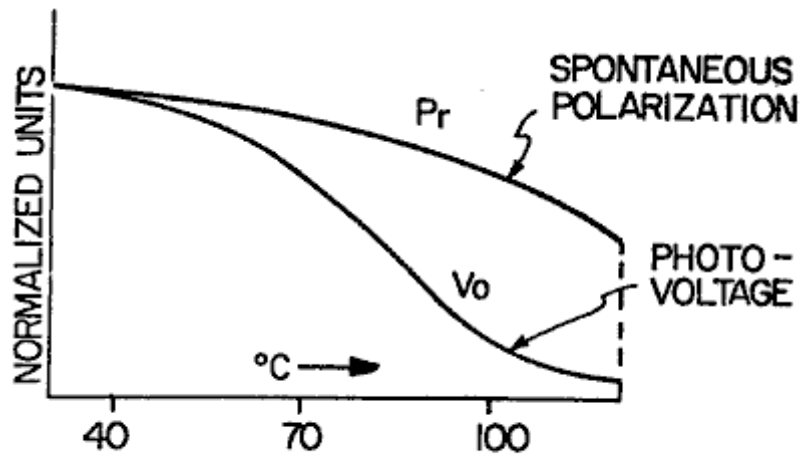

FIG. 16

Fig.17 is a diagram illustrating the photo-voltage vs. temperature of single crystal BaTiO₃ ;

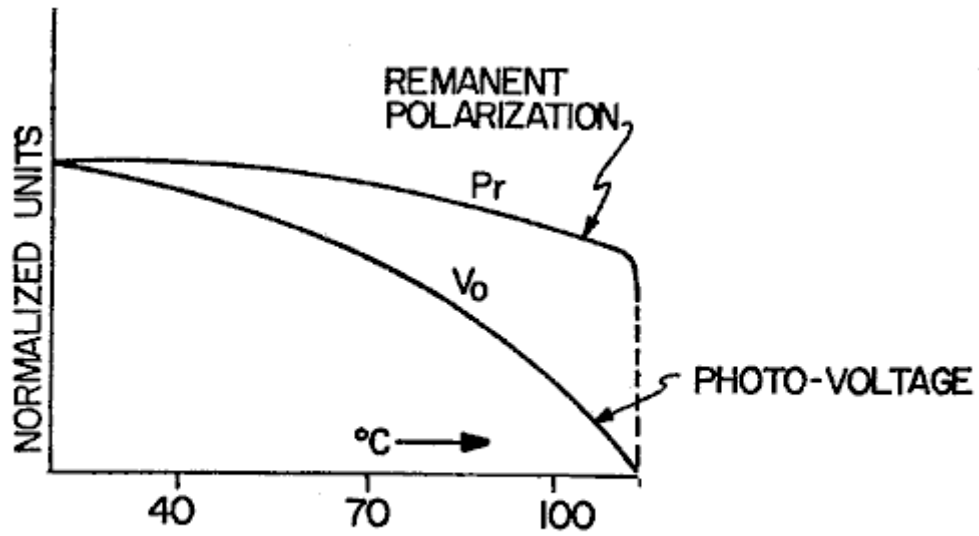

FIG. 17

Fig.18 is a diagram illustrating photo-current vs. temperature for BaTiO₃ + 5% by weight of CaTiO₃ ;

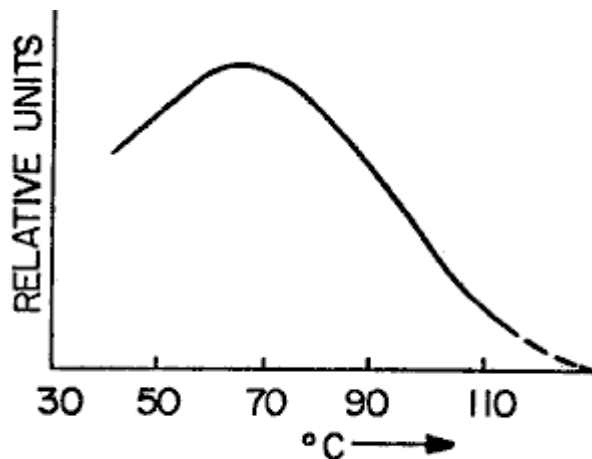

FIG. 18

Fig.19 is a cross-sectional, elevational view schematically depicting the ceramic slab of **Fig.1**, with the photo-emf appearing across the electrodes on the edge, and with most of the photo-current flow being found in the shaded region near the surface;

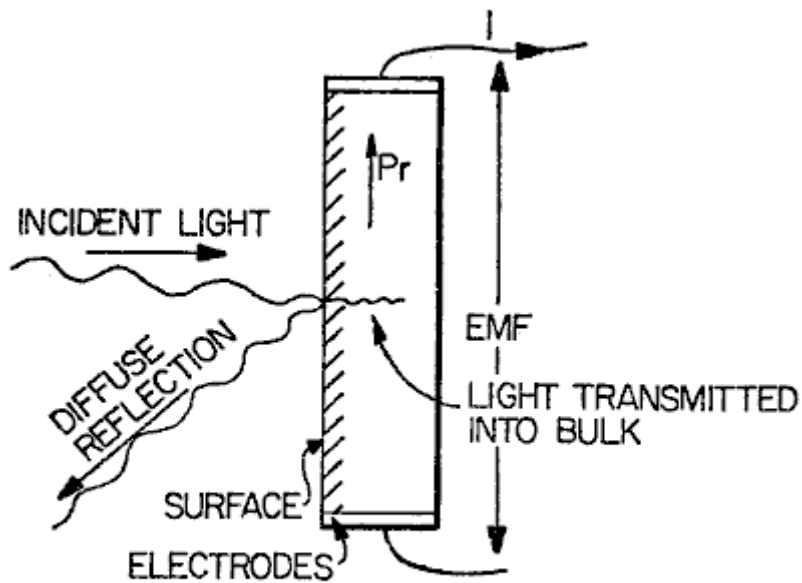

FIG. 19

Fig.20 is a cross-sectional, elevational view of a slab of ferroelectric ceramic material utilising transparent electrodes and depicting light incident through the transparent electrodes into the slab with the slab being polarised in the thickness direction;

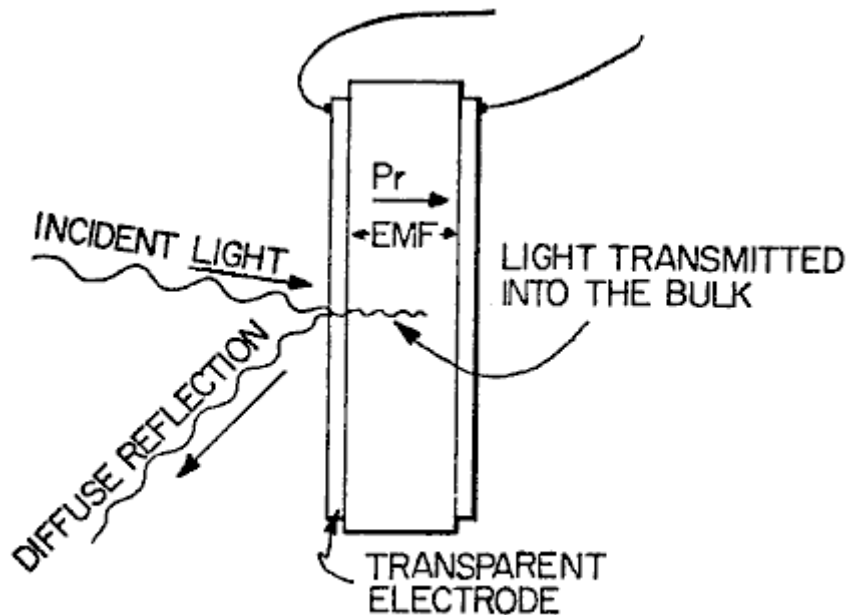

FIG. 20

Fig.21 is a cross-sectional diagrammatic illustration of a single layer of grains depicting the manner in which photo-emf's are produced across the grains in an additive fashion to produce a length dependent effect in the ceramic material, the illumination being incident from the left-hand portion of the drawing and being typically quickly absorbed as it penetrates the material;

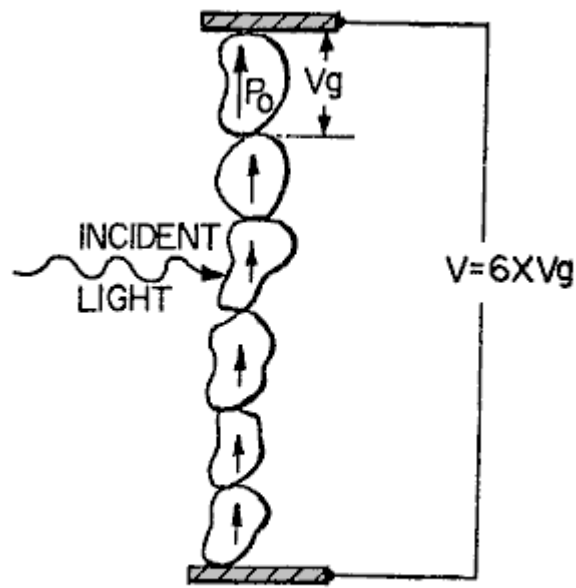

FIG. 21

Fig.22 is a diagram illustrating idealised two dimensional crystals of length l with spontaneous polarisation P_s , dielectric constant ϵ_b compensating surface charge per unit area of $\sigma = P_s$;

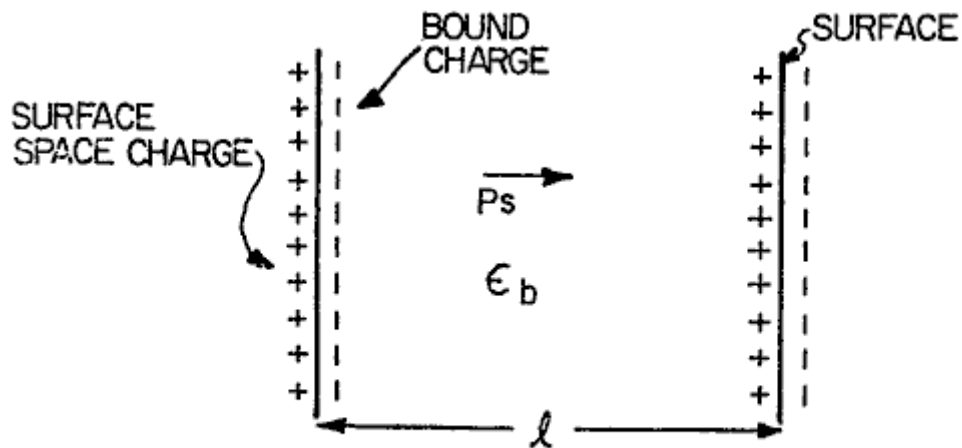

FIG. 22

Fig.23 is an illustration depicting the structure of a typical ferroelectric grain or crystallite;

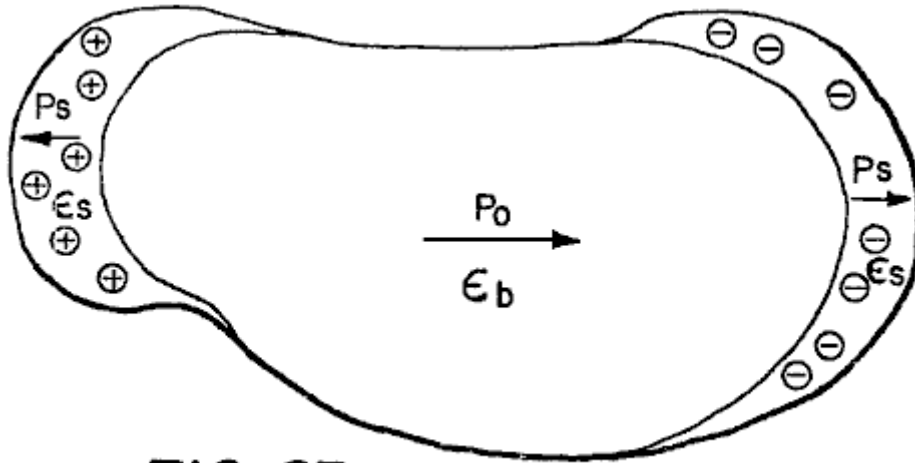

FIG. 23

Fig.24 is an illustration depicting a model of a crystal of length l ;

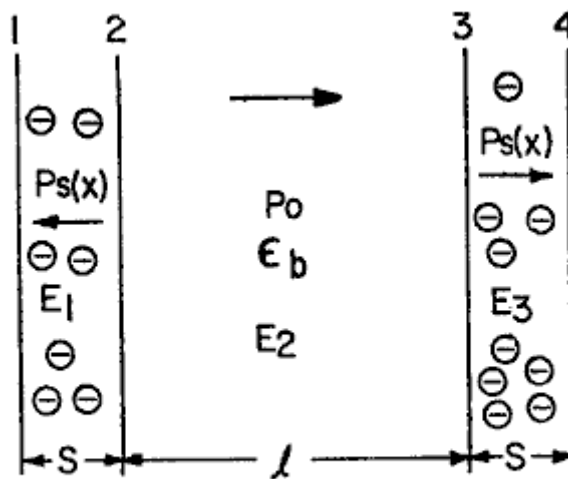

FIG. 24

Fig.25 is a diagram illustrating the potential distribution in an illuminated crystal;

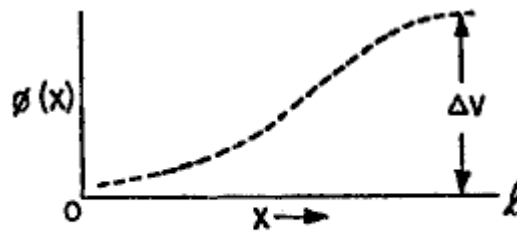

FIG. 25

Fig.26 is a schematic representation of the instant inventive ferroelectric ceramic substrate utilised as a photovoltaic memory device with optical scanning;

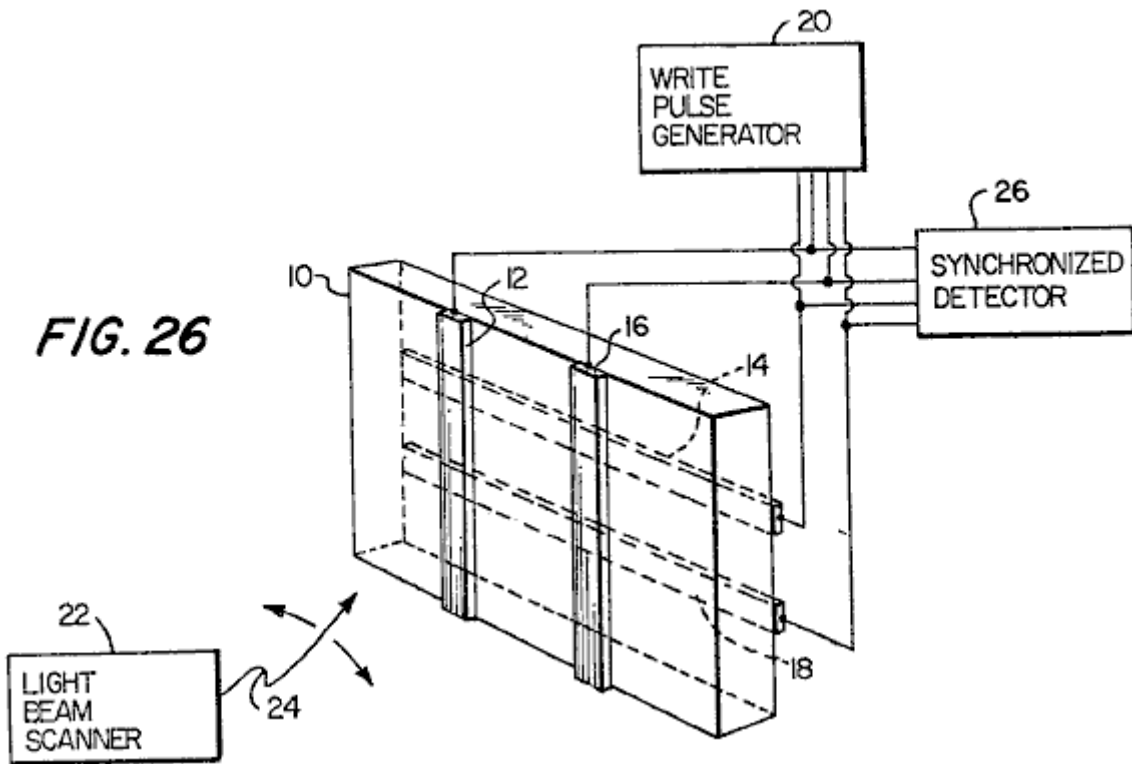

Fig.27 is a schematic illustration of an optical display apparatus utilising a ferroelectric ceramic material in accordance with the general teachings of the instant invention;

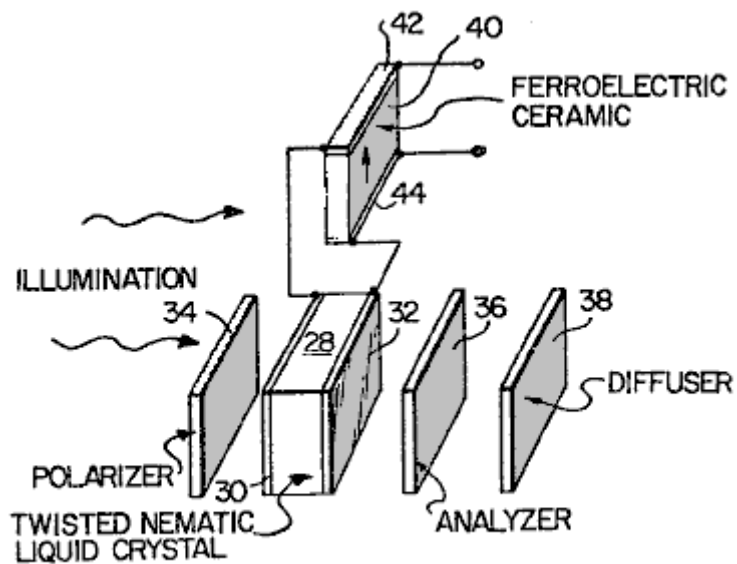

FIG. 27

Fig.28 is a schematic illustration depicting an optical display apparatus constructed in accordance with the teachings of the instant invention in monolithic form utilising a colour switching liquid crystal;

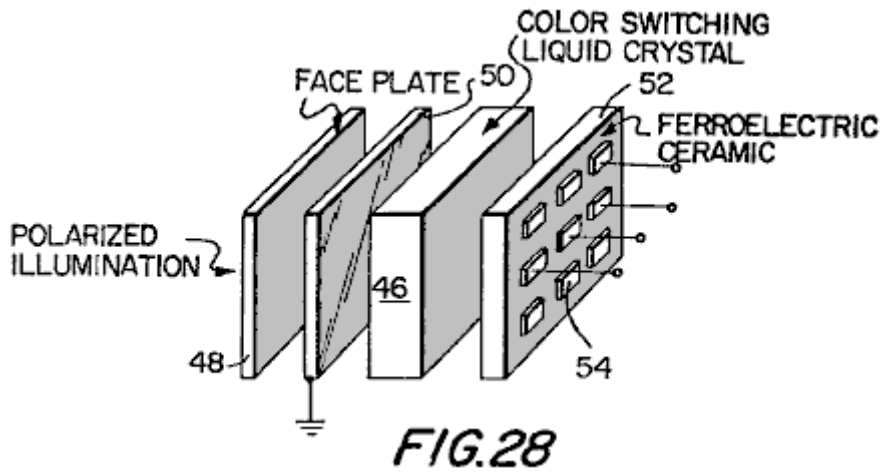

Fig.29 is a schematic illustration of the display apparatus of **Fig.28**, modified to make utilisation of a twisted nematic liquid crystal;

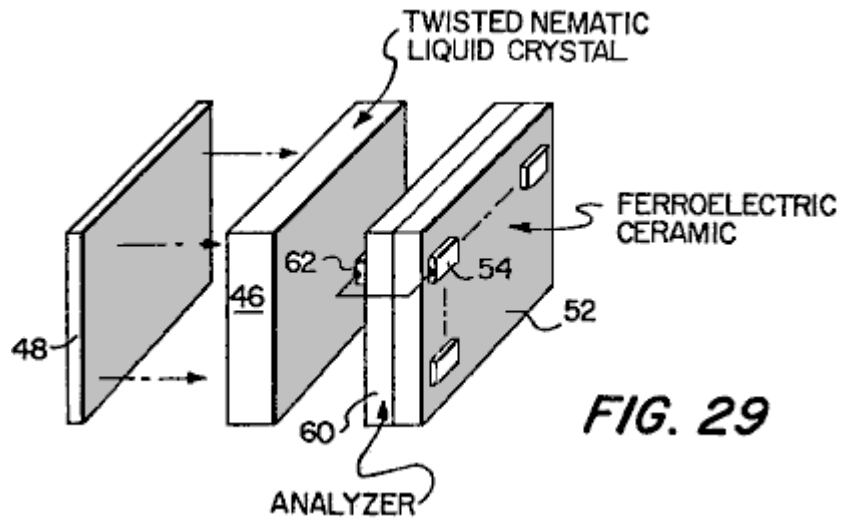

Fig.30 is a cross-sectional elevational view depicting an optical display apparatus utilising a colour switching liquid crystal in conjunction with a ferroelectric ceramic substrate of the instant invention, and which display apparatus exhibits permanent memory capabilities;

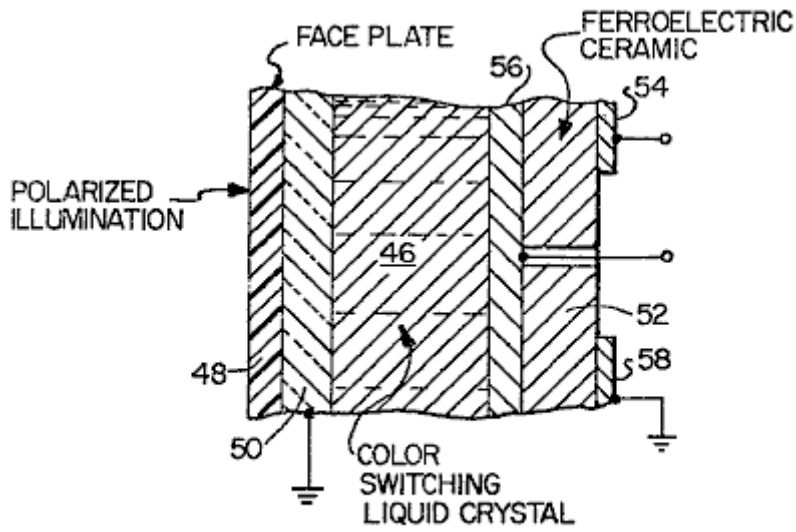

FIG. 30

Fig.31 is a cross-sectional elevational view of a further form of an optical display apparatus constructed in accordance with the teachings of the instant invention, said apparatus utilising a colour switching liquid crystal and further utilising length-wise polarisation of the ceramic substrate;

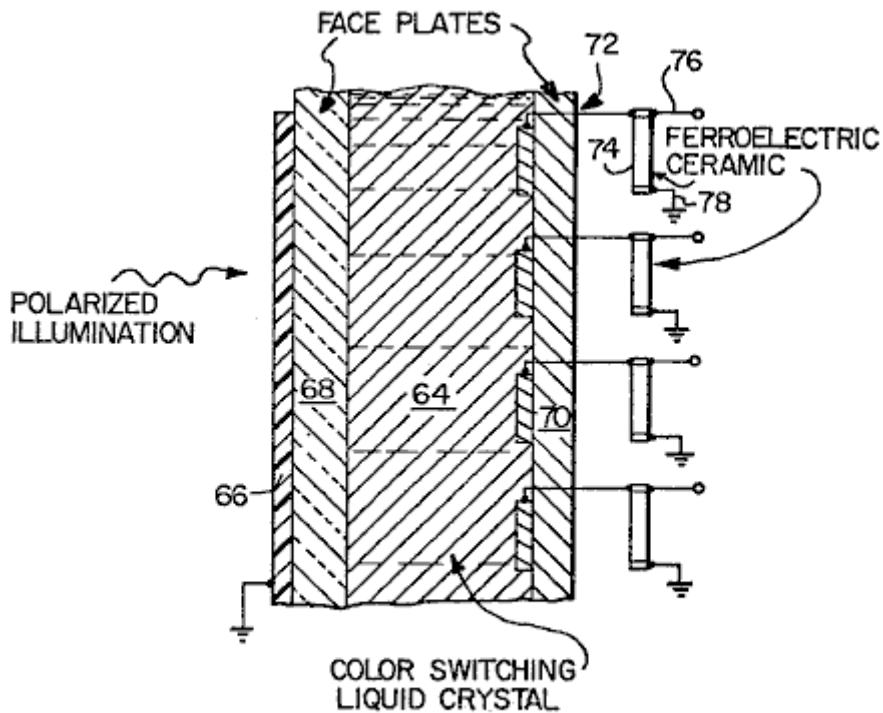

FIG. 31

Fig.32 is an elevational view, in section, of a further form of an optical display apparatus constructed in accordance with the teachings of the instant invention, this apparatus being similar to that depicted in **Fig.31** of the application drawings but utilising a liquid crystal of the twisted nematic type; and

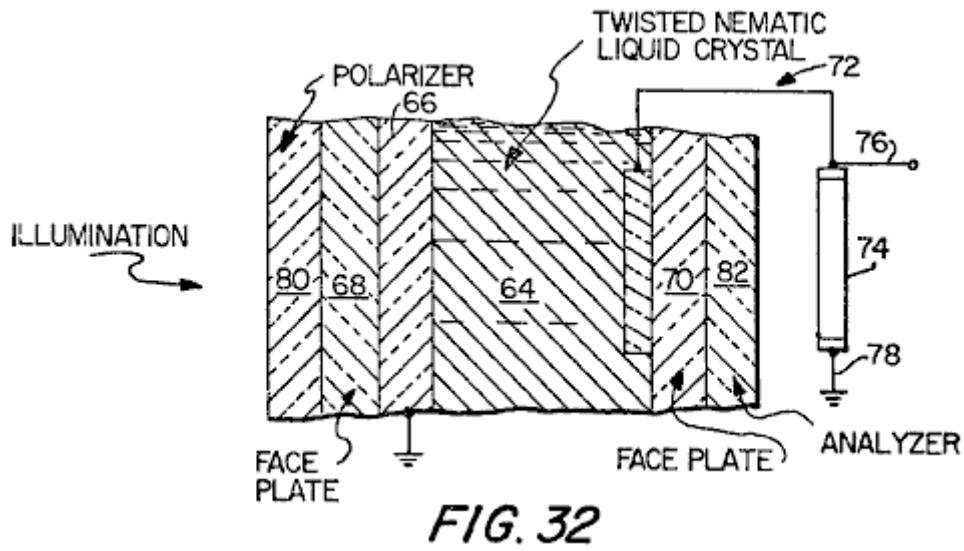

Fig.33 is a schematic illustration of a further form of optical display and storage utilising the photoconductive as well as photovoltaic properties of the ferroelectric ceramics.

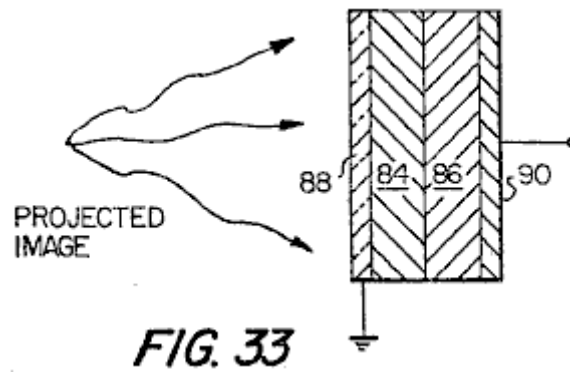
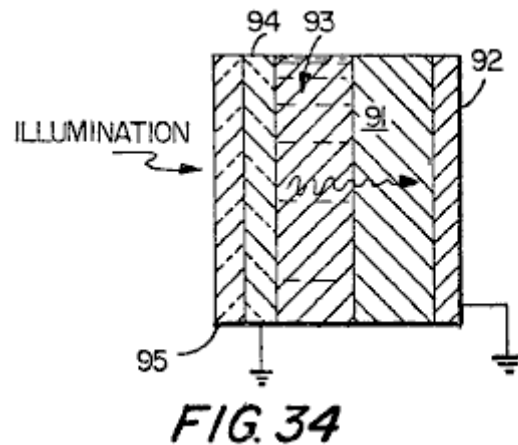

Fig.34 illustrates how the image stored in a substrate is displayed.



DETAILED DESCRIPTION OF THE PREFERRED INVENTIVE EMBODIMENTS

With reference now initially to **Fig.1** of the application drawings, a discussion of the novel phenomena of the instant invention will ensue. Upon the application of incident illumination to the ferroelectric ceramic, a steady voltage is produced which is proportional to the length l between the electrodes. By dividing the sample into two equal segments along a line perpendicular to the direction of the remanent polarisation and by placing new electrodes on the cut edges, new samples would result each producing photo-emf's which is one half the original photo-emf.

An arrangement such as that shown in **Fig.1** can be described roughly by the equivalent circuit as shown in **Fig.2**. This has a saturation photo-emf V_0 , in series with the photo resistance of the illuminated sample. **Fig.3** is a current-voltage characteristic of a typical illuminated ferroelectric slab, and has the form expected from the equivalent circuit in **Fig.2** except for the slight tendency towards saturation in the lower left quadrant. As a function of intensity, the photo-emf saturates at relatively low levels of illumination. The short circuit photo-current is, however, linear with light intensity. Results for the material $Pb(Zr_{0.53}Ti_{0.47})O_3$ with 1% by weight of Nb_2O_5 are shown in **Fig.4**. The implication of these results and the equivalent circuit in **Fig.2** is that the photo-resistance R_{ph} is inversely proportional to intensity.

A saturation photo-emf and a short circuit current proportional to intensity has been measured in several poled ferroelectric materials. These are shown in Table I:

Table I

Photovoltaic outputs at room temperature for several ceramic compositions. The wafers were fully poled, to their maximum remanent polarization. Filtered illumination had a half bandwidth of about 10 nm. The photo-emf is a saturation value reached at relatively low value of intensity.

Sample	Illumination Wave length (nm)	Saturation Photo-emf (Volts/cm)	Short Circuit Photocurrent (μ Amperes/cm) watts/cm ²
Pb(Zr _{0.53} Ti _{0.47})O ₃ + 1 wt% Nb ₂ O ₅	373	610	.31
BaTiO ₃ + 5 wt% CaTiO ₃	403	360	.020
Pb(Zr _{0.65} Ti _{0.35})O ₃ with 7% lanthanum-lead substitution	382	1500	.030
Pb(Zr _{0.65} Ti _{0.35})O ₃ with 8% lanthanum-lead substitution	382	750	.015
BaTiO ₃ + 5wt% CaTiO ₃	403	355	.02
Pb(Zr _{0.53} Ti _{0.47})O ₃ + 1wt% Nb ₂ O ₅ with polished surfaces	382	610	~.61

For a given composition the photo-emf is also a function of grain size. These results are shown in Table II.

Table II

Photo-emf for different grain size and percent lanthanum substituted for lead. The materials are Pb(Zr_{0.65}Ti_{0.35})O₃ with 7% lanthanum substitution for lead and the same material with an 8% lanthanum substitution for lead.

Grain Size (microns)	Percent Lanthanum-Lead Substitution (percent)	Saturation Photo-emf (Volts/cm)
2-4	7	1500
4-6	7	980
greater than 6	7	560
2-4	8	750
3-5	8	510
4-6	8	330
greater than 6	8	250

the photo-voltage v. number of grains per unit length is plotted in Fig.5 for two different compositions. The plot clearly shows a relationship between the two quantities.

The fact that the photo-emf of a particular sample depends on the remanent polarisation is shown by the results for a typical ferroelectric material, barium titanate + 5% by weight of CaTiO₃, as plotted in Fig.6.

The short circuit photo-current depends strongly on the wave length of the impinging illumination. It is a maximum at a wavelength resulting in a photon energy equal to the band gap energy of the material. Other wavelengths can, however, contribute strongly to the current.

Results for typical materials are shown in Fig.7, Fig.8, and Fig.9. The current (ordinate) is that produced by illumination contained in a small band, of about +10 nm about a wavelength indicated on the abscissa. A mercury source and notch type dichroic filters were used. The total intensity within each band was only roughly constant.

The current that has been plotted has been therefore normalised to constant intensity by assuming the linear relation between the two.

The photo-emf is less strongly dependent on wave length. Results for a particular material, using notch dichroic filters is shown in **Fig.10**. These values are saturation values, roughly independent of intensity.

An important additional phenomena shows a dependence of current produced in the red and infrared regions in the presence of simultaneous blue band gap radiation. These results are shown in **Fig.11** and **Fig.12**. The ordinate (**Fig.11**) is the current produced by the light from a mercury arc shining through dichroic long wavelength cut off filters, the abscissa the wavelengths above which no light illuminates the sample. Note the step at 650 nm. Using short wavelength cut off filters which eliminate the band gap light results in no current until the cut off wavelength is below the band gap. These results are shown in **Fig.12**. The amount of output in the red actually depends on the intensity of simultaneous band gap radiation, thus the energy efficiency of these materials for a broad band source is not simply the intensity weighted average of the efficiencies for individual wavelengths as produced by notch filter. The actual value is larger.

Photo-emf vs. cut-off wavelength for $\text{Pb}(\text{Zn}_{0.53}\text{Ti}_{0.47})\text{O}_3$ +1% by weight of Nb_2O_3 is shown in **Fig.13**. A substantial photo-emf appears at long wavelengths but no current can flow. In other words, the internal resistance R_{ph} is extremely high unless band gap is incident.

Single Crystal Results

The ceramic results imply a small photo-emf from a single crystal illuminated as shown in **Fig.14**. Such emf = 0.55V at room temperature was indeed observed.

The short circuit current is, as for the ceramic material, a strong function of wavelength. These results are shown in **Fig.15**.

Temperature Dependence

Ceramic photo-emf is a function of temperature. Results for barium titanate ceramic with 5% by weight of CaTiO_3 are shown in **Fig.16**. For both $\text{Pb}(\text{Zn}_{0.53}\text{Ti}_{0.47})\text{O}_3$ with 1% by weight of Nb_2O_5 added and barium titanate the photo-emf decreases with increasing temperature. In these measurements, the temperature ranged to the transition temperature, the photo-emf vanishing at the temperature at which the remanent polarisation also vanishes. The remanent polarisation vs. temperature for this material is also shown in **Fig.16**. Similar results for single crystal barium titanate are shown in **Fig.17**. The single crystal photo-emf are, of course, much smaller. Short circuit was measured as a function of temperature. Results for barium titanate +5% by weight of CaTiO_3 are shown in **Fig.18**. Similar results over the same temperature range were obtained for $\text{Pb}(\text{Zn}_{0.53}\text{Ti}_{0.47})\text{O}_3$ + 1% by weight of Nb_2O_5 material. In that case there was no maximum, the photo-current still increasing with increasing temperature at 130°C .

Effects of Optical Properties

In the arrangement shown in **Fig.1**, the direction of polarisation, and consequently the direction of the photo-emf is perpendicular to the direction of incidence of the light which is also the direction in which the light is strongly absorbed. The light only enters into a region near the surface of the material. The rapidity of the absorption depends strongly on the wavelength of the light, the light becoming fully absorbed in a region closer and closer to the surface as one decreases the wavelength of the light and approaches the band gap wavelength. For shorter wavelengths, the light no longer enters the material and thus for these wave lengths the light-induced effects decrease rapidly with decreasing wavelength.

Ceramic materials which exhibit these photo-emf's can appear transparent, translucent, and apparently opaque when viewed with white light. Light, however, obviously enters even the opaque materials to produce the photo-emf's. The apparent opacity is produced by diffuse reflection at granular boundaries. It is of course desirable to minimise the degree to which diffuse reflectivity prevents light from entering the material. Nevertheless, the largest photo-currents and greatest photovoltaic efficiency has been originally observed in a material which appears opaque in thickness more than a few thousandths of an inch. The cross sectional drawing **Fig.19** depicts the way light enters the material with the arrangement as originally shown in **Fig.1**.

When a circuit connects the electrodes, the maximum density of current occurs near the surface, the current density decreasing in regions deeper within the thickness.

Polishing the surfaces of these materials, however, increases the transparency and, as expected, the magnitude of the photo-current and the photovoltaic conversion efficiency. An emf will also be produced by the arrangement shown in **Fig.20** provided, of course, that the electrodes are of a nature to allow light to enter the material. Normal thick metal electrodes are opaque to light. When metal electrodes are thin enough, they permit light to be transmitted and yet are sufficiently conductive to function as electrodes. Other conducting transparent electrodes include indium oxide. The emf now will be seen to appear across the thickness of the material, in the direction of the remanent polarisation.

In this arrangement the high dark resistance of any un-illuminated bulk portion of the material is in series with the circuit connecting the electrodes. The current that can be drawn is limited. Maximum currents can be drawn when the thickness between the electrodes is equal to or less than the absorption depth of the radiation. However, since the saturation photo-emf is not a strong function of intensity, vanishing only for extremely low intensities, the full photo-emf per unit length v_0 can usually be observed for this samples.

Proposed Mechanism for the High Voltage Photovoltaic Effect in Ferroelectrics

Briefly, it is proposed that the photo-emf results from the action of an internal field within the bulk of an individual ceramic grain on non-equilibrium carriers generated by illumination. These carriers move to screen the internal field. The photo-emf that appears is the open circuit result of such screening. A change in charge distribution upon illumination changes the voltage across a grain from an initial value of zero to the photo-voltages which are observed.

These photo-emf's appears across individual ceramic grains. What is observed as a length dependent high photo-voltage is the series sum of the photo-emf's appearing across grains, each of which is characterised by saturation remanent polarisation P_0 . The situation is shown schematically in **Fig.21**. Individual grains typically are small, of the order of 10 microns in diameter. To produce a high photo-voltage per unit length in the ceramic the voltage across an individual grain need not be large. For example the results in **Table II** for $Pb(Zn_{0.65}Ti_{0.47})O_3$ with 7% Lator Pb can be explained by individual grain photo-voltage of only about 0.5 volts per grain. The clear implication of the experimental results (**Table II** and **Fig.5**) is that for the range of grain sizes investigated, the photo-emf across a grain is more or less independent of the size of the grain. This is supported also by the single crystal results.

Ferroelectric crystals are characterised by large spontaneous polarisation which would be expected to produce large emf's even in the dark. Such emf's are not observed even across highly insulating materials. This is presumed to be the result of space charge within the volume or on the surface of a ferroelectric crystal (which, in ceramics, are the individual grains or crystallites). The space charge produces a potential across a crystal cancelling the potential produced by the net polarisation within they crystal. It is obvious that as long as there are sufficient charges within the crystal which are free to move, any potential produced by an internal polarisation will eventually vanish.

This dark zero potential state is the initial state of a crystal crystallite, grain, and of the ceramic body composed of these grains. The absence of a net potential in the dark does not however mean the absence of internal fields. Internal fields can be expected to exist and are the consequence of the spatial distribution of the charges which bring the net potentials across grains to zero. These spatial distributions can not be arbitrarily assigned, but are subjected to constraints of a basic physical nature.

In the idealised two dimensional crystal shown in **Fig.22**, the surface charge density $Upsilon = P_s$ reduces the potential between the surfaces to zero. If the surface charge density (in actuality this does not occur) is completely juxtaposed upon the bound polarisation surface charge, which has a value P_s , then there are no internal fields. Were there no charge, the crystal would show an internal field P_s/ϵ_0 and a potential between the surfaces of $P_s l / \epsilon b$.

Such a field would be well above the dielectric breakdown strength of a real dielectric. For a single domain typical ferroelectric barium titanate $P_s = 26 \times 10^{-2}$ C/m, and the relative dielectric constant ϵ_r in the direction of polarisation is 137. The field that would have to exist in the absence of compensation charge is over 2×10^6 volts/cm which is well above the dielectric strengths typical of these materials. If such a field could momentarily exist within a ferroelectric crystal it would not exist for long but be reduced from its maximum value to some value below the dielectric strength of the material. The strong field would break down the material and a charge flow would produce a space charge distribution resulting in a new lower value for the internal fields within the crystal.

Such a space charge distribution must exist in an actual crystal. The space charge serves to reduce the potential across a crystal to zero. Such charges have limited mobility and the materials continue to behave as insulators for ordinary strength applied fields.

Such a space charge cannot occupy a delta function-like region as in the idealised situation shown in **Fig.22**, but must occupy instead a finite volume. If these are localised near the surface of the crystal, then an internal field E_{ϵ_b} exists within the bulk of the material and additional fields E_s exist within the space charge regions near the surface.

It is hypothesised that these space charge regions are near the surface of real crystals with the charge distributed within a surface layer thickness s . The reasons for same are as follows:

- (1) The surface regions of ferroelectric crystals are characterised by regions whose dielectric, ferroelectric, and thermodynamic properties differ markedly from that of the bulk. These differences are best explained by the existence of strong fields in this region that would be produced by space charge. There is a considerable body of information in the literature supporting the existence and delineating the properties of these layers;
- (2) The interplay of space charge and the very non-linear dielectric constant of ferroelectric would be expected to localise space charge in a low dielectric constant layer near the surface. In ferroelectrics, unusually high, low field relative dielectric constants (of the order of 1000) can be expected to reduce in value with increasing field strength. Thus charge in a region reduces the dielectric constant of that region increasing the field strength of that region. This feedback mechanism can be shown to localise charge within a layer.

The experimental results supporting the existence of surface layers will not be reviewed here, nor the calculations which support the localisation of charge into layers as a result of a non-linear (saturable) dielectric constant. These may be reviewed by referring to the literature.

A schematic description of a typical grain, i.e. crystallite, with space charge regions of thickness s , and a bulk region of thickness l , is shown in **Fig.23**. The internal fields (in the two dimensional model) of such a charge distribution superimposed on that produced by the bound polarisation charge will be calculated and also the effect of these fields on carriers within the bulk produced as the result of an internal photo effect (photo-ionisation). Formulae for the photo emf that will be derived will have the correct sign, a linear dependence on remanent polarisation, and the kind of temperature dependence that has actually been observed. In addition there will result an estimate of a size independent grain photo-emf for a typical ferroelectric, barium titanate, which is consistent with that implied from the observed ceramic emf, and single grain emf. The grain has as shown in **Fig.23**:

- (1) A bulk region with dielectric constant ϵ_b and uniform polarisation (at zero applied field) P_0 ;
- (2) Surface layers of dielectric constant ϵ_s , considerably less than that of the bulk. There are also polarisation in the surface regions $P_s(x)$ which exist at zero applied field. These will generally be parallel to the bulk polarisation at one end and anti-parallel at the other end;
- (3) Space charges in these surface layers which serves to remove any potential across the grain. It is the space charge layers which produce high fields which reduce the highly non-linear dielectric constant of the bulk to the lesser value in the surface layers, and also produce the remanent polarisation, $P_s(x)$ with the surfaces.

Such a structure also has an internal bulk field, and surface fields which can be calculated. For the purposes of this calculation we assume a simple two dimensional model shown in **Fig.24**.

The polarisation with the various regions are assumed only for simplicity to be uniform within these regions. Again, only for simplicity those in the surface layers and the bulk are assumed equal in magnitude (i.e. $P_s(x) = P_0$). The space charge densities $+n_0e$ are also assumed uniform and equal in magnitude. The polarisations are equivalent to four bound surface charge densities,

$$\sigma_1 = P_0 \quad \sigma_2 = -2P_0$$

$$\sigma_3 = 0 \quad \sigma_4 = -P_0$$

There are, using Gauss's law, electric fields as shown in **Fig.24**.

$$E_1 = \frac{1}{\epsilon_s} [P_0 + n_0 \rho x]$$

$$E_2 = \frac{1}{\epsilon_b} [-P_0 + n_0 \rho s]$$

$$E_3 = \frac{1}{\epsilon_s} [-P_0 + n_0 \rho (s-x)]$$

It has been assumed that the voltage across the crystal vanishes,

$$\int_0^{l+2s} E(x) dx = 0$$

n_0 and s , from this and the three preceding equations, must be related by the expression

$$m_0 e s = \frac{P_0}{1 + \frac{\epsilon_b}{\epsilon_s} \frac{s}{l}}$$

and the bulk field

$$E_2 = \frac{-P_0}{\epsilon_b} \left[\frac{\frac{s}{e} \frac{\epsilon_b}{\epsilon_s}}{1 + \frac{s}{l} \frac{\epsilon_b}{\epsilon_s}} \right]$$

Surface layers in barium titanate ceramic grains have been estimated at 10^{-6} cm (see for example Jona and Shirane Ferroelectric Crystals, Pergamon Press, 1962). The remanent polarisation typical of the ceramic material is about 8×10^{-2} C/m², the relative dielectric constant of the poled ceramic about 1300. The high field dielectric constant will be estimated at roughly 0.5 the bulk dielectric constant. These numbers yield a bulk field, for a typical 10^{-3} cm grain of,

$$E_2 = 350 \text{ volts/cm}$$

The potential across the bulk would thus be approximately -0.35 volts. The remaining potential across the grain would be that across the surface layers. Illumination has the effect of producing charges which screen the internal field, E_2 causing it to vanish.

The negative voltage vanishes and a positive potential appears across the sample. The light makes the sample look more positive. This is exactly what happens as the result of a thermally-induced decrease in polarisation. Thus the pyro-electric voltage is in the same direction as the photo-voltage as is experimentally observed.

In the fully screened case, the photo-emf is also the emf across the two surface layers

$$\Delta V = \left[\frac{P_0}{\epsilon_s} \frac{1}{1 + \frac{\epsilon_b}{\epsilon_s} \frac{s}{l}} \right] S \approx .35 \text{ volts}$$

The light generated free electrons sets up a counter field which tends to cancel the bulk field E_2 ; thus, the observed voltage drop is less than it would be in a perfectly insulating medium. This is what is meant by the term 'screening'. The counter field approaches $-E_2$. Assuming the shielding occurs only in the bulk, the total voltage across the grain is now the sum of the voltages across the surface layers.

The photo-emf is in the opposite direction to the bulk polarisation. This fact predicted in the theory is what is always observed experimentally. The complete screening of the bulk field thus would, in barium titanate, be expected to result in a photo-emf of +0.35 volts per grain or 350 V/cm and about 0.35 volts across a macroscopic single crystal. These are roughly the values actually observed as seen in **Table I**, and with the single crystal results. The linear relation between remanent polarisation and saturation photo-emf as shown in **Fig.6** is also predicted by these equations. The dependence on temperature of the photo-emf as shown in **Fig.16** and **Fig.17** is predicted by the fact that as one approaches the curie temperature, not only is P_0 decreasing but the dielectric .epsilon..sub.s is increasing. The bulk internal field, E_2 , should therefore decrease with temperature more rapidly than the remanent polarisation.

Screening

Solving the general problem of screening in a ferroelectric is difficult. Many of the principles involved can be demonstrated by solving a special case. The special case is meant to be particularly applicable to the $\text{Pb}(\text{Zr}_{0.53}, \text{Ti}_{0.47})\text{O}_3 + 1\%$ by weight of Nb_2O_5 material.

Utilised, only for simplicity, is a two dimensional model, with photo-produced carriers limited to those of a single sign. It will be assumed that these are electrons generated from deep trapping levels midway in the band gap, and that the illumination empties all the traps leaving fixed positive charges to replace the original traps. The complete emptying of a deep trapping level would produce the long wave length photo-voltages and the phenomena of an intensity saturation of the photo-emf typical of the $\text{Pb}(\text{Zr}_{0.53}, \text{Ti}_{0.47})\text{O}_3 + 1\%$ by weight of Nb_2O_5 .

Consider a two dimensional illuminated slab of length l within which is an internal field **Epsilon** and within which, light generates a uniform density of electrons n_0 (n electrons per unit length). Schematically the situation is shown in **Fig.25**, where **Phi.(x)** is the potential at a point **x**.

The carriers respond to the internal field and occupy a Boltzman distribution

$$M = M_0 e^{\psi / kT}$$

if the fields due to the electrons could be neglected, then

$$\psi(x) = -Ex$$

This is, of course, too rough an approximation. With $n(0)$ the density of electrons at $x=0$, and n_0 , the density of the immobile donor ions $m(x) = m(0)e^{\psi(x)/kT}$ with $\psi(x)$ is given by Poisson's equation,

$$\frac{d^2\psi}{dx^2} = \frac{e}{\epsilon} [m(x) - m_0] = \frac{e}{\epsilon} [m(0)e^{\psi(x)/kT} - m_0]$$

Since for $\psi = 0$ $n(0) = n_0$, and since all traps are emptied, assuming electrical neutrality,

$$\int_0^l m_0 \int_0^l e^{\psi/kT} dx = m_0 l$$

or

$$m_0 \int_0^l e^{\psi/kT} dx = m_0 l$$

then

$$\int_0^l \frac{d^2\psi}{dx^2} dx = \int_0^l \frac{e}{\epsilon} [m(x) - m_0] dx = 0$$

or

$$\left. \frac{d\psi}{dx} \right|_{x=l} = \left. \frac{d\psi}{dx} \right|_{x=0}$$

If the crystal is neutral there must be no electric field at the boundary except the applied field $-E_0$.

$$\left. \frac{d\psi}{dx} \right|_{x=0} = E_0$$

$$\left. \frac{d\psi}{dx} \right|_{x=l} = E_0$$

These two boundary conditions allow the solution of Poisson's equation.

$$\frac{d^2\psi}{dx^2} = \frac{m\phi}{\epsilon} \left[\frac{m(o)}{m_o} e^{\psi/kT} - 1 \right]$$

or

$$\frac{d^2\psi}{dx^2} \left[\frac{e^{\psi}}{kT} \right] = \frac{M\phi^2}{\epsilon kT} \left[\frac{M(o)}{M_o} e^{\psi/kT} - 1 \right]$$

substituting

$$y_0 = \ln \frac{M_o}{m(o)} \quad y = \frac{e^{\psi(x)}}{kT}, \quad l_D^2 = \frac{\epsilon kT}{m\phi^2}$$

we obtain,

$$\frac{d^2y}{dx^2} = \frac{1}{l_D^2} [e^y - y - 1]$$

in this new notation,

$$\left. \frac{dy}{dx} \right|_{x=0} = \left. \frac{dy}{dx} \right|_{x=l} = \frac{eE_o}{kT}$$

let

$$\frac{dy}{dx} = p$$

$$\frac{d^2y}{dx^2} = \frac{dp}{dx} = \frac{dy}{dx} \frac{dp}{dy} = p \frac{dp}{dy} = \frac{d}{dy} \left(\frac{1}{2} p^2 \right)$$

so

$$\frac{d}{dy} \left(\frac{1}{2} p^2 \right) = \frac{1}{l_D^2} [e^y - y - 1]$$

setting $y(o)=0$ since the zero for a potential may be set arbitrarily

$$\frac{1}{2} p^2(l) - \frac{1}{2} p^2(o) = \frac{1}{l_D^2} \int_0^l (e^y - y - 1) dy$$

$$= \frac{1}{l_D^2} [e^{y(l)} - y - y(l) - e^{-y(o)}]$$

$$y(o) = \frac{e^{\psi(o)}}{kT}$$

$$y(l) = \frac{e^{\psi(l)}}{kT}$$

$$\left. \frac{dy}{dx} \right|_0 = \left. \frac{dy}{dx} \right|_l = p(o) = p(l)$$

so

$$O = \frac{1}{l_D^2} e^{-y} [(e^\Delta - 1) - \Delta]$$

$$\text{where } \Delta = \frac{e}{kT} \Delta v \text{ or } e^y = \frac{e^\Delta - 1}{\Delta}$$

$$\text{and thus } \frac{M_0}{M(O)} = \frac{e^\Delta - 1}{\Delta} = \frac{\frac{e}{kT} \Delta v - 1}{\frac{e}{kT} \Delta v}$$

substituting

$$\frac{d}{dy} (\frac{1}{2} p^2) = \frac{1}{l_D^2} \left[\frac{\Delta}{e^\Delta - 1} e^y - 1 \right]$$

so

$$\begin{aligned} \frac{1}{2} p^2(x) - \frac{1}{2} p^2(0) &= \frac{1}{l_D^2} \left[\frac{\Delta}{e^\Delta - 1} (e^y - 1) - y \right] \\ &= \frac{1}{l_D^2} \left[\Delta \frac{e^y - 1}{e^\Delta - 1} - y \right] \end{aligned}$$

Thus

$$\left(\frac{dy}{dx} \right)^2 = \left(\frac{eF_0}{kT} \right)^2 + \frac{2}{l_D^2} \left\{ \Delta \left(\frac{e^y - 1}{e^\Delta - 1} \right) - y \right\}$$

or

$$\frac{dy}{dx} = \frac{\sqrt{2}}{l_D} \sqrt{\Gamma^2 + \Delta \left(\frac{e^y - 1}{e^\Delta - 1} \right) - y}$$

where

$$\Gamma^2 = \frac{1}{2} \frac{e}{kT} E_0 l_D$$

integrating this equation from 0 to 1 yield

$$\int_0^{x(l)} \frac{dy}{\sqrt{\Gamma^2 + \Delta \left(\frac{e^y - 1}{e^\Delta - 1} \right) - y}} = \frac{\sqrt{2}}{l_D} \int_0^l dx$$

or,

$$\int_0^\Delta \frac{dy}{\sqrt{\Gamma^2 + \Delta \left(\frac{e^y - 1}{e^\Delta - 1} \right) - y}} = \frac{\sqrt{2}l}{l_D}$$

which is an implicit expression for ΔV in terms of E_0 , l , and l_D .

For low n_0 and/or large E_0 , Γ is large

$$\int_0^\Delta \frac{dy}{\sqrt{\Gamma^2}} = \frac{\sqrt{2}l}{l_D}$$

$$\Delta = \sqrt{2} l \Gamma / l_D$$

or

$$\begin{aligned} \Delta &= \sqrt{2} l \times \frac{1}{\sqrt{2}} \left[\frac{e}{kT} E_0 l_D \right] l_D \\ &= \frac{e}{kT} E_0 l \end{aligned}$$

or

$$\Delta V = E_d$$

which is the original potential across the bulk of the crystal.

The situation of interest is however large n_0 and small l_D and small Γ^2 .

It is in this situation that

$$\Delta = \frac{e}{KT} \Delta V$$

can be expected to vanish.

Expanding the expression for Δ small, which is always the case, then

$$\Delta \frac{e^y - 1}{e^{\Delta} - 1} - y \approx \frac{1}{2}y^2 - \frac{1}{2}y\Delta$$

Keeping only second order terms in y and Δ , then

$$\int_0^{\Delta} \frac{dy}{\Gamma^2 + \frac{1}{2}(y^2 - y\Delta)} = \frac{l\sqrt{2}}{l_D}$$

Let

$$\xi = y - \frac{\Delta}{2},$$

this becomes

$$\int_{-\Delta/2}^{\Delta/2} \frac{d\xi}{\sqrt{\Gamma^2 - \frac{1}{4}\Delta^2} + \frac{1}{2}\xi} = \frac{l\sqrt{2}}{l_D},$$

Setting

$$\xi = \sqrt{2\Gamma^2 - \left(\frac{\Delta}{2}\right)^2} \sin h^{-1} O$$

gives

$$2\sqrt{2} \sin h^{-1} \left[\frac{\Delta/2}{\sqrt{2\Gamma^2 - \left(\frac{\Delta}{2}\right)^2}} \right] = \frac{\sqrt{2} l}{l_D}$$

or

$$\Delta = 2 \sqrt{2} \Gamma \tanh h \frac{l}{2l_D}$$

or

$$\Delta V = E_o (2l_D) \tanh h \frac{l}{2l_D},$$

clearly as

$$l_D \rightarrow 0 \quad \Delta V \rightarrow 0$$

This approximation for ΔV is good for all reasonable values of T .

Illumination thus reduces the dark bulk emf = $E_o l$, producing a net photovoltage

$$V_{PHOTO} = E_o l \left[1 - \frac{\tanh h \frac{l}{2l_D}}{\frac{l}{2l_D}} \right]$$

where

$$l_D = \sqrt{\frac{EkT}{m_o e^2}}$$

A simplified expression occurs for small

$$\frac{l}{2l_D}$$

where, $\tanh x \approx x - \frac{1}{3}x^3$

$$V_{PHOTO} = E_o l \left[\frac{1}{2} \left(\frac{l}{2l_D} \right)^2 \right]$$

Here, it is clear that the photovoltage becomes insignificant for

$$\frac{l}{l_D}$$

The implication is therefore that photovoltaic contributions from the bulk will be much larger than that from the surface layers, for surface layers are extremely small while l_D can be estimated as very roughly equal in the bulk and the surface.

Thus, illumination will result in the vanishing of the internal field within the bulk resulting in a maximum photo-emf.

$\Delta V = 0 \quad E_2 l$ where E_2 is the bulk field.

For small intensities, we can assume n_o small, then

$$V_{PHOTO} = E_o l \frac{1}{4} \frac{n_o e^2}{ekT}$$

i.e., the photo-voltage is proportional to n_0 which can be reasonably assumed proportional to intensity which is experimentally observed (see **Fig.4**).

The model just described explains the long wave length photo-emfs, in the material $Pb_{(0.53}Zr_{0.47}Ti)O_3 + 1\%$ by weight of Nb_2O_5 . Such a deep trapping level is probably typical of the lead titanate-lead zirconate materials with characteristic lead vacancies. These bind electrons leaving holes (producing p type dark conductivity). The addition of common dopants -- for example niobium gives rise to free electrons which combine with holes or get trapped by the lead vacancies. The doping can thus be said to provide electrons which fill traps.

It is these trapped electrons which are photo-injected into the conduction band by the long wave length light providing near maximum photo-emfs in material illuminated at 500 nm and even longer wave lengths as shown in the results plotted in **Fig.13**. Full saturation, that is the complete shielding of the bulk internal field, requires however band gap carriers which occurs as one approaches the 373 nm band gap wave length. Solving this problem, that of band gap carriers in addition to electrons generated by deep traps, can be accomplished in a manner similar to that which was accomplished for the trapped electrons but is more complex for example because mobile holes are being produced in addition to electrons and one cannot necessarily fix the maximum number of carriers.

The photo-emfs are created by photo-induced carriers shielding the bulk field. Effectively, no photo-current can flow however unless band gap light is present as is clear from the results shown in **Fig.12** and **Fig.13**. Here it is clear the band gap light produces maximum photo-emf and maximum photo-currents, less than band gap light, maximum or almost maximum photo-emf but no photo-currents and that the output resistance under these circumstances appears extremely high. Addition of band gap light allows current to flow.

The tentative explanation is that the surface layers from high resistance barriers, the magnitude of which lowers with band gap light. The surface layers thus act as intrinsic photoconductors in series with an emf. This picture not only explains the rather unique dependence of photo-emf and short circuit photo-current on wave length as shown in **Fig.12** and **Fig.13** but also the equivalent circuit which is typical of all these materials as described in **Fig.2** and as indicated by the current-voltage results in **Fig.3**.

A possible explanation for the high resistance of the surface layers is that they include quantities of charged ions which have been localised there. These are immobile under normal applied voltages moving only under the action of high fields such as produced by the reversal of the remanent polarisation. Those ions not only will occupy trapping levels, eliminating the need for easily ionised trapped electrons and thus reducing the intrinsic conductivity but also form centres for coulomb scattering of conduction electrons which should contribute markedly to the resistivity.

Efficiency

Some insight into the possible maximum efficiency of the process can be obtained by considering carriers generated by band gap light. with potential energy

$$U = 2 \int_0^L e^{-\alpha(x)} \delta M_2 dx$$

with $\alpha(x) < Ex$

so that a maximum value of energy

$$\begin{aligned} U &= 2e \int_0^L E \delta m dx \\ &= e \delta m_0 EL^2 \end{aligned}$$

The energy required to produce δm_0 electron hole pairs

$$\epsilon = \delta M_0 L E_g$$

where E_g is the band gap energy.

The power into the crystal is

$$P_m = LEg \frac{\delta M_0}{\delta t}$$

while the power out (the rate of increase in internal potential energy) is

$$P_{out} = eEL^2 \frac{\delta M_2}{\delta T}$$

The efficiency

$$= \frac{eEL}{E_g}$$

For $\text{Pb}(\text{Zr}_{.53}\text{Ti}_{.47})\text{O}_3 + 1 \text{ wt\% Nb}_2\text{O}_5$, added E is roughly 600 v/cm and the grain size roughly 5 microns. The emf across a grain is thus about .3 volts. The band gap is about 3 eV. Thus the efficiency is

$$\approx \frac{.3}{3} \approx 10\%$$

Which compares with an observed band gap efficiency of about 0.06%. The calculation, of course, depends on idealising assumptions, some of which may be practically obtainable.

PHOTOVOLTAIC MEMORY DEVICE

With the above background and general teachings of the unique discovery of the invention now firmly in mind, numerous and important applications of the properties of the ferroelectric ceramics above-discussed are readily possible as will be evident to those skilled in this art. For example, the device of the instant invention will be shown to exhibit particular utility as a memory apparatus, thus making use of the property of the ferroelectric ceramic defined as remanent polarisation or "memory" as previously explained.

With particular reference now to **Fig.26** of the application drawings, one such photovoltaic memory apparatus is disclosed, the memory apparatus being optically addressed. In this respect, a substrate or sheet of a ferroelectric ceramic material of the type above-discussed is indicated by reference numeral 10 as being "sandwiched" between at least one pair of electrodes such as electrodes 12 and 14 positioned on opposing sides of the substrate.

In the preferred embodiment as shown, an array of electrode pairs, such as pairs 12-14 and 16-18 are disposed on opposing sides of the substrate 10 as to define a matrix configuration. Information is put into the memory and particularly into the region of the substrate 10 lying between electrode pairs by temporarily applying a voltage pulse of a predetermined polarity between the electrode pairs, such pulse being provided by the Write Pulse Generator 20 coupled to the various electrodes and of typical construction. Specifically, if a positive voltage pulse was provided by the Write Pulse Generator 20 between electrode pairs 12-14, with electrode 12 being presumed to be the positive electrode in this example, a remanent ferroelectric polarisation will take place in the region of substrate 10 lying between the crossed electrode pair, this remanent polarisation being in a direction and of a polarity dependent upon the polarity of the write pulse.

Similarly, if a negative voltage pulse was applied between electrode 16 on the one hand, and electrode 18 on the other hand, with electrode 16 in this instance being presumed to have the negative polarity, a remanent polarisation within the ferroelectric ceramic 10 will take place in the region disposed between the intersecting or crossed electrodes 16 and 18. In a similar fashion, predetermined remanent polarisation can be produced individually in all of the regions of the ferroelectric ceramic 10 that are disposed between crossed electrode pairs of the matrix array in direct dependence upon the polarity of the write pulse voltage applied, this remanent ferroelectric polarisation constituting stored information in that such polarisation within the ceramic will remain until removed by the application of a write voltage pulse of opposing polarity.

In accordance with the teachings of the instant invention, these stored "bits" of information in the form of remanent ferroelectric polarisation within the various regions of the substrate 10 can be extracted or "read" by selectively illuminating the poled regions of the substrate with a beam of light, as preferably can be provided by a laser, for example. Upon illumination, the polarised regions of the ferroelectric ceramic will produce a photovoltaic current and voltage at an associated electrode pair, with the polarity of the photo-current and photo-voltage being

dependent upon the "stored" remanent ferroelectric polarisation or "information" within the particular region of the substrate.

In the preferred embodiment of the device wherein a so-called matrix configuration of the electrode pairs are provided, the entire ferroelectric ceramic substrate can be scanned by the illuminating beam which is contemplated to be continuously swept in the fashion of a "light pencil" by a light beam scanner of conventional construction as is designated by reference numeral **22**, for example, light beam scanner **22** providing the sweeping illuminating beam designated by reference numeral **24**. Further, and in this particular embodiment, the illumination from the light beam **24** would be transmitted into the associated poled regions of the ferroelectric ceramic **10** by passing through electrodes **12**, **16** etc. disposed on the surface of the ceramic facing the illuminating beam, electrodes **12**, **16**, etc. being constructed so as to be transparent.

The generated photovoltaic currents and voltages at the electrode array would be detected by a synchronised detector designated by reference numeral **26** coupled to each of the electrode pairs, detector **26** being of conventional construction and serving to monitor the polarity of the photovoltaic currents and voltages developed in time synchronism with the light beam scanner **22**. Such synchronism can be effected through a direct coupling of the detector **26** to the light beam scanner **22** in typical fashion, or through the utilisation of an external computer clock, all in accordance with standardised matrix memory addressing techniques.

Optical Display Apparatus

The discovered properties of the ferroelectric ceramic substrate of the instant invention can further be applied in conjunction with liquid crystals to fabricate a novel display apparatus and, in this respect, attention is generally directed to **Fig.27** to **Fig.32** of the appended application drawings.

The operational principle associated with the fabrication of such optical displays relies upon the utilisation of the photovoltaic currents and voltages generated by substrates of a ferroelectric ceramic material to effect switching of the opacity state of a liquid crystal operating in the field - effect mode. This generalised combination will be seen to provide a write-in read-out memory and optical display. Both the liquid crystal and the ferroelectric ceramic effectively function as a memory, either in a binary or bi-stable mode having two possible states designated as an "on" state or an "off" state wherein the liquid crystal is switched from a substantially transparent condition to a substantially opaque condition, or in a multi-state mode by which the transmission characteristics of the liquid crystal are varied through many states to effect a so-called gray scale display.

With particular reference to **Fig.27** of the application drawings, a typical optical display device following the general teachings of the instant invention is shown, such display device providing so-called dark spot display capabilities. As depicted in **Fig.27**, a twisted nematic liquid crystal is designated by reference numeral **28**, such crystal being sandwiched between two transparent electrodes **30** and **32**.

As is known, the twisted nematic liquid crystal **28** will vary its transmission characteristic to incident light dependent upon the polarity and magnitude of a voltage applied across electrodes **30** and **32**. Specifically, the twisted nematic liquid crystal **28** serves to transmit illumination through it as long as there is no voltage across electrodes **30** and **32**. In conjunction with the twisted nematic liquid crystal **28**, a linear polariser **34** is provided, as is an analyser **36** of conventional construction. The linear polariser **34** and the analyser **36** are crossed so that no light passes through the combination to a diffuse reflector **38** except for the fact that the twisted nematic liquid crystal cell interposed between them rotates the polarisation of the incident illumination by 90° so as to allow passage of light. Application of a voltage across the cell electrodes **30** and **32** destroys the ability of the liquid crystal cell **28** to rotate the plane of the polarisation of the illumination and the illumination is consequently absorbed in the analyser **36** rather than transmitted and reflected off the diffuse reflector **38**.

Accordingly, when voltage is applied across electrodes **30** and **32**, a dark colour of the liquid cell would be displayed in so-called dark spot display. The magnitude of the display is dependent upon the magnitude of the applied voltage, such that a voltage applied across cell electrode **30** and **32** less than a characteristic amount necessary to effect full plane rotation will only partially reduce the rotating ability of the liquid crystal **28** thereby resulting in only a partial extinction of illumination and the generation of a gray-scale display. The above discussion of the operation of a so-called twisted nematic liquid crystal is entirely conventional.

To obtain the switching voltage for application to the cell electrodes **30** and **32**, a substrate of a ferroelectric ceramic designated by reference numeral **40** it utilised, the substrate **40** being sandwiched between electrodes **42** and **44** as shown, ceramic substrate **40** being disposed such that the illustrated illumination impinges not only on the liquid crystal **28**, but also on the ceramic substrate. As illustrated, electrodes **42** and **44** of the ceramic substrate **40** are respectively coupled to the transparent electrodes **30** and **32** of the twisted nematic liquid crystal cell **28**.

Initially, a polarisation voltage is applied to the ferroelectric ceramic substrate **40** across the associated electrodes **42** and **44**, such voltage being in the form of a pulse and serving to produce a remanent polarisation in the direction of the arrow shown within the substrate. Subsequently, and in accordance with the teachings of the invention, when the substrate **40** is illuminated, a current will flow in a circuit connecting terminal **42** to terminal **30** of the liquid crystal cell **28**, through the cell **28** to electrodes **32**, and then to terminals **44** of the ceramic substrate **40**, this current being a photovoltaic current proportional to the magnitude of the remanent polarisation effected within the ferroelectric ceramic by the initial application of the polarisation voltage pulse.

The magnitude of the photovoltaic current can be varied in accordance with the generalised teachings of the instant invention discussed at the outset by simply varying the magnitude of the initial polarising pulse. The so-called gray-scale display capability of the light transmission characteristics of the liquid crystal **28** is provided simply through a pre-selection of the magnitude of the remanent polarisation produced and, of course, assuming a constant intensity illumination. The memory characteristics of the ferroelectric ceramic **40** are inherently brought about in that the value of the photovoltaic current can be changed only through the application of another polarising pulse. Thus, the generalised apparatus of **Fig.27** functionally constitutes an apparatus which effects an optical display of the state of the memory within ferroelectric ceramic substrate **40**.

In the embodiment as described in **Fig.27**, a so-called "dark spot display" was effected. In the event that a so-called "bright spot" is desired to appear during the "on" state of the liquid crystal in transmission or reflection, polariser **34** and analyser **36** would be disposed in a parallel relationship with respect to one another, rather than crossed. Further, and although the basic embodiment above-discussed refers to the utilisation of liquid crystals of the twisted nematic type, similar results can be obtained with so-called colour switching crystals which, in like fashion, alter their light transmission characteristics to incident polarised light in response to the application of a voltage across them.

In accordance with the generalised teachings of **Fig.27**, various other forms of optical displays can be constructed. For example, and with particular reference to **Fig.28** of the application drawings, a different form of combined memory and optical display apparatus is illustrated, this apparatus making use of a colour switching liquid crystal **46** instead of the twisted nematic liquid crystal **28** of **Fig.27**. As was explained above, the colour switching liquid crystal such as crystal **46** serves to alter its light transmission characteristics to incident polarised light, and it is for this reason that the light source illustrated in **Fig.28** is defined as being polarised illumination, although it is to be understood that in this embodiment, as well as in the following embodiments to be discussed which use colour switching liquid crystals, a non-polarised light source can be provided if a linear polariser is disposed within the apparatus on the side of the liquid crystal nearest the incoming illumination.

The display apparatus of **Fig.28** defines a so-called monolithic structure as opposed to the exemplary structure of **Fig.27** wherein the liquid crystal was physically spaced from the energising ferroelectric ceramic. In **Fig.28**, a "sandwich" construction is provided comprising a face plate **48**, a transparent electrode **50** coupled to ground, the colour switching liquid crystal **46**, a slab or substrate of a ferroelectric ceramic **52**, and a plurality of electrodes such as electrodes **54** coupled to the ferroelectric ceramic **52** in an array.

When a short voltage pulse is initially applied between the ground electrode **50** and one of the polarity of rear electrodes **54**, the region of the liquid crystal **46** immediately in front of the rear electrode **54** will become transparent resulting in a potential appearing between the semi-transparent ground electrode **50** and the rear electrode **54** due to the incident illumination. In this instance, the ferroelectric ceramic material **52** would preferably be a transparent ceramic, such as 0.020 inch disk of 8.5/65/35 PLZT with a grain size of 6 microns, polarised in the thickness direction and producing a photo-emf of about 30 volts and a short circuit current of 10^{-7} amperes/cm.² per watt per cm.² input at 388 nm, for example. Further, the rear electrodes **54** are contemplated to be of a transparent variety, such as indium oxide **50** that a display can be provided in transmission.

A further variant of the operation of the device of **Fig.28** is possible, eliminating the necessity for the initial application of a short voltage pulse between the ground electrode **50** and one of the plurality of rear electrodes **54** to commence the process of clearing of the liquid crystal **46**. In this respect, and in addition to the normally provided uniform polarised illumination, an additional intense source of light providing a thin beam such as a laser would be provided, the laser constituting a so-called "light pencil". Upon application of the intense pencil beam of light of the apparatus of **Fig.28**, such intense light would penetrate the liquid crystal even in its nominally closed state thus illuminating the ferroelectric ceramic **52**, such illumination causing a photo-voltage to be generated as above-discussed which would then appear across the liquid crystal in the region of the intense light beam causing that region to become transparent and allowing the uniform polarised illumination to penetrate into that region, such uniform illumination further clearing the crystal in a regenerative process. This would result in a clear region which looked bright under reflected light, and a current flowing from the associated rear electrode **54** to ground, for example, through a non-illustrated resistor that would be provided. With this modification, the intense beam of

light constituting the "light pencil" can be utilised to actually enter a line drawing into the display, with a point by point read-out being provided.

As opposed to obtaining a point-by-point electrical read-out, the image written-in by the "light pencil" can be externally projected. In this respect, and as explained, the "image" constitutes transparent sections of the liquid crystal. If a light source such as a tungsten-halogen lamp normally associated with projectors was additionally provided to illuminate the display apparatus from the "rear" thereof in a direction opposing the direction of the incident polarised illumination, such auxiliary light source would pass through the display apparatus at the transparent regions, much in the same manner as a photographic slide is projected, the projection image being displayed on a suitable screen. In this instance, of course, a ferroelectric ceramic material that is transparent would be required, such as the material known as PLZT 7/65/35.

As can further be appreciated, the memory characteristics of the optical display of **Fig.28** are not permanent. If domain switching and a permanent memory capability is desired, an alternative electrode configuration would be required in the fashion illustrated in **Fig.30** of the application drawings, components of the apparatus of **Fig.30** that are the same as those of **Fig.28** being represented by the same reference numerals. Specifically, an additional transparent electrode **56** would be disposed between the colour switching liquid crystal **46** and the ferroelectric ceramic **52** polarisation within the ferroelectric ceramic **52** being effected by the application of a voltage pulse across electrodes **54** and **56**, and with an additional grounding electrode **52** being provided on the ceramic **52** as is shown so as to couple one end of the ferroelectric ceramic **52** to the transparent electrode **50**.

If a twisted nematic liquid crystal were desired to be utilised in the generalised configuration of the optical display of **Fig.28**, a still further modification of the electrode arrangement would be needed and, in this respect, attention is directed to **Fig.29** of the application drawings. Like parts in this figure are again represented by the same reference numerals.

Initially, since a twisted nematic liquid crystals alters its light transmissions characteristics by rotating the plane of the polarisation of the illumination, a further polariser such as analyser **60** is required to be disposed between the ferroelectric ceramic **52** and the liquid crystal **46**, the crystal **46** thereby being properly responsive to incoming polarised illumination either provided directly by a polarised source, or provided through the utilisation of a non-polarised illumination source in conjunction with a polariser such as polariser **34** of the embodiment of **Fig.27**. Additionally, a light transmitting electrode **62** would be disposed on the surface of the analyser **60** immediately adjacent the liquid crystal **46**, transparent electrode **62** being coupled through the analyser and the ferroelectric ceramic substrate **52** to an associated rear electrode **54**. Each of the rear electrodes **54** of the array would have associated therewith an additional transparent electrode **62** in similar manner.

If the analyser **60** was constructed to be crossed with the incoming polarised illumination, the liquid crystal **46** would normally transmit light through it and, upon the application of a voltage between electrode **54** and the front transparent electrode **50**, would cause the apparatus to provide a so-called "dark spot display." Alternatively, if the incoming polarised light has a plane of polarisation parallel to the polarisation plane of analyser **60**, a so-called "bright spot display" would result. It should further be appreciated that the embodiment of **Fig.29** can be utilised with a "light pencil" to provide a functional operation similar to that discussed with respect to **Fig.28**.

Attention is now directed to **Fig.31** of the application drawings wherein an illustration is provided of an optical display array utilising a liquid crystal **64** of the colour switching type. Each of the units shown is contemplated to represent one of the horizontal row in an overall array. The structure illustrates is in monolithic form and, as shown, constitutes a polarity of superposed layers. Specifically, a transparent electrode **66** is provided, behind which is the liquid crystal **64** disposed between two face plates **68** and **70**. A transparent electrode structure **72** is provided imbedded at one end with the liquid crystal **64** and coupled at the other end to one end of the ferroelectric ceramic substrate **74** as is shown. The other end of each ferroelectric ceramic slab **74** is commonly coupled to ground along with the front transparent electrode **66** as was discussed.

With the embodiment of **Fig.31**, each ferroelectric ceramic substrate **74** would be initially polarised by the application of a polarising voltage pulse between the representative terminals or electrodes **76** and **78**, for example. Now, upon the application of illumination to the ferroelectric ceramic, a photovoltaic voltage will be generated which appears between the front transparent electrode **66** and the rear transparent electrode **72** causing the liquid crystal **64** between these electrodes to become transparent.

Liquid crystal **64** would normally be in a nominally opaque state. However, sufficient light would be transmitted through the liquid crystal material so as to produce the photo-voltage in the ferroelectric ceramic **74**, which photo-voltage applied to the electrodes **66** and **72** in a positive feed-back arrangement serves to increase the transparency of the colour switching liquid crystal **64** in the region between the electrodes. This increased transparency, in turn, increases the voltage output of the ferroelectric material **74** which further increases the transparency of the liquid crystal **64** such that a transparent region would be formed appearing as a bright spot

with reflected light. The surface of the ferroelectric ceramic **74** would in this instance serve itself as a diffuse reflector which would be required by a display function in the reflection mode.

Further, it should be appreciated that a certain threshold light transmission of the liquid crystal **64** would be required to begin this process of creating a transparent region. If the liquid crystal is sufficiently thick, the transmitted light through the crystal in its normally opaque state would be insufficient to commence this clearing process and an applied voltage would be initially necessary across the crystal to commence the process, this voltage being used as a "read" signal.

As can be appreciated, the remanent polarisation of the ferroelectric ceramic material **74** in the embodiment depicted in **Fig.31** is along the length of the ceramic substrate. An alternate arrangement is possible wherein the memory writing is accomplished by altering the remanent polarisation of the ferroelectric ceramic in the thickness direction. In this respect, reference is once again made to **Fig.30** of the application drawings illustrating the disposition of a ferroelectric ceramic **52** in conjunction with the colour switching liquid crystal **46** such that the remanent polarisation of the ceramic is achieved in the thickness direction, and such that permanent memory characteristics are imparted. With this arrangement, the incident illumination would be quickly absorbed in the surface of the ferroelectric ceramic material but would still penetrate sufficiently so as to produce relatively large photovoltaic voltages.

Finally, the optical display device of **Fig.31** can be constructed with a twisted nematic liquid crystal as opposed to the colour switching liquid crystal of **Fig.31** and attention is herein directed to **Fig.32** of the application drawings. Again, components of the apparatus of **Fig.32** which are similar to those in **Fig.31** are represented by the same reference numeral.

In this embodiment, a polariser **80** would initially be provided so as to polarise the incoming illumination. In a fashion similar to the generalised embodiment of **Fig.27**, an analyser **82** would likewise be provided, polariser **80** and analyser **82** being assumed to be parallelly disposed. Incoming polarised light will not impinge on the ferroelectric ceramic material **74** because the twisted nematic crystal **64** would rotate the plane of the polarisation of the illumination by 90° and such illumination would thus be absorbed in analyser **82**. The display unit, accordingly, would initially be in an "off" or dark state and no voltage would exist across the terminals or electrodes **76** and **78** of the ferroelectric ceramic.

The "on" of the display apparatus would be bright under reflected illumination and would be indicated by the appearance of a DC voltage across terminals **76** and **78**. The unit would be switched to the "on" stage through the application of an initial polarising voltage pulse between electrodes **76** and **78**. The twisted nematic liquid crystal would now lose its ability to rotate the plane of polarisation of the illumination and light would fall on the surface of the now-polarised ferroelectric ceramic material **74** such that the ceramic would generate a steady, high photovoltaic voltage which would appear across the electrodes of the liquid crystal. This photovoltaic voltage would prevent the liquid crystal from returning to the twisted phase and the liquid crystal would thus remain transparent and a voltage potential would be maintained across the electrodes for the duration of the illumination.

The display apparatus can be returned to its dark state simply by shorting across terminals **76** and **78** and the crystal cell would return to its opaque condition with no voltage appearing across the electrodes. A new external voltage pulse would be required across electrodes **76** and **78** to again switch the unit on. It should be appreciated that only a momentary voltage pulse is required to turn the display unit on, and only a momentary short circuit is needed to turn the unit off.

If the incident illumination were interrupted, the display unit would likewise be put into an "off" state. The memory characteristics of the display apparatus thus are volatile in the sense that a removal of illumination will put the display unit into an "off" state. Permanent memory characteristics can be obtained by depoling the ferroelectric ceramic **74** with additional circuitry and the illumination could then be interrupted. When illumination is restored, a voltage pulse would switch "on" only those units of the array which were in an "on" state at the time of interruption of illumination, since only the polarised ferroelectric ceramic units will produce a photo-voltage. The depoled units can then be repoled without switching them "on", utilising a suitable circuit to apply a polarising voltage to the ceramic but not to the liquid cell to therefore retain the liquid crystal cell in its dark state as it was at the time the illumination was removed.

Many other different embodiments combining a liquid crystal display with the ferroelectric ceramic substrate of the instant invention can be fabricated along the generalised teachings referred to above. From the standpoint of materials selection, PLZT is desired when a transparent ferroelectric ceramic is required, and other ferroelectric ceramics such as $\text{Pb}(\text{Zr}_{0.53}\text{Ti}_{0.47})\text{O}_3 + 1\%$ by weight of Nb_2O_5 (i.e. PZT-5), a solid solution of lead titanate, and lead zirconate can be utilised when relatively cheap "opaque" materials are acceptable. With the display devices as above-discussed, typical thickness of the ferroelectric ceramic material are on the order of 0.020 inches. In accordance with the generalised teachings appearing at the outset of this specification, it is to be appreciated that

the photovoltaic output of the ferroelectric ceramic material is proportional to the material length and, the higher the photovoltaic output, the faster the switching time of the associated liquid crystal.

A further form of optical display apparatus is contemplated herein by which the previously discussed photoconductive properties of ferroelectric ceramic materials are utilised in the formation of display apparatus. As will be recalled and appreciated, the resistivity of typical ferroelectric ceramic materials varies as a function of the illumination incident thereon and thus, the voltage drop across illuminated regions of a ferroelectric ceramic substrate that has a polarising voltage applied thereto would be less than the voltage drop across non-illuminated or dark regions of the ceramic. Attention in this respect is directed to **Fig.33** of the application drawings.

The display device depicted in **Fig.33** is such that a photograph in the form of a projected image can be stored in a ferroelectric ceramic sheet or substrate **84** as a pattern of poled ferroelectric regions where the remanent polarisation of such regions is simply related to the intensity of the projected image at that point. The pattern of poled regions can be produced by the already discussed technique of a photoconductive ferroelectric sandwich, or by utilising the photoconductive properties of ferroelectric materials directly.

In the embodiment of **Fig.33**, an image is projected onto a ferroelectric-photoconductive substrate **84**, which substrate is backed by a sheet of resistive material **86** such as evaporated carbon, semiconductor material or the like. A transparent front electrode **88** forming a ground plane covers the surface of the ferroelectric material **84**, which material is of the type which would exhibit a sizable polarisation dependent photovoltaic effect. A further electrode **90**, covers the rear surface of the resistive material **86**, and a polarising voltage would be applied to the apparatus between electrodes **90** and **83**.

With such an arrangement the voltage drop will be seen to exist across those regions of the ferroelectric substrate **84** which are illuminated will be less than the voltage drop apparent across the non-illuminated or dark regions. As such the lower remanent polarisation within the ferroelectric material will be effected than in those regions of the ferroelectric material that are not illuminated by the projected image. Accordingly a "negative" of the projected image would thus be stored in the ferroelectric substrate or sheet **84** as regions of varying remanent polarisation. In that the ferroelectric **84** is photovoltaic having polarisation dependent photo-voltages as discussed this stored image is now read out electrically utilising the techniques already described with respect to the embodiments of the invention illustrated in **Fig.26** of the application drawings or **Fig.28** et. seq. of the application drawings. It is displayed by applying the photo-voltages from regions of polarisation in which the image is effectively stored to liquid crystal electrodes as for example is illustrated in **Fig.34** of the application drawings where illumination sufficiently strong penetrates the dark liquid crystal **93**, to in a regenerative fashion, apply the photo-voltage from polarised region **91**, to the liquid crystal region immediately adjacent varying in intensity depending on the value of the polarisation. A negative image is produced in reflection.

High Voltage Battery

The teaching in this patent may be applied toward the provision of a novel high voltage battery serving to convert radiation such as X-radiation in this instance, directly into electrical energy. In this respect, a block or substrate of ferroelectric ceramic material would again be provided to which electrodes are attached in the identical fashion as was discussed with respect to the basic physical configuration of the invention illustrated in **Fig.1** of the application drawings. An example of the constituent material of the ferroelectric ceramic in this instance is solid solution PZT-5A consisting of 53 mole percent $ZrTiO_3$ and 47 mole $PbTiO_3$ with 1 percent by weight of niobium added such as Nb_2O_5 . This ferroelectric ceramic material would be poled in the usual fashion by the application of a high voltage applied across the electrodes.

To function as a battery, the ceramic material can contain a radioactive component and this can be all or a portion of any of the above-discussed constituent elements. For example, the material may be fabricated with a radioactive isotope of Zr, TiO, Nb, etc., or a radioactive additive can be added to the composition. Alternatively, the composition may be placed next to a strong radioactive source and, for example, could actually be coated with a radioactive material. The primary requirement is that a flux of gamma rays or X-rays within the material be produced, which radiation has the effect of ionising the ferroelectric ceramic material so as to produce non-equilibrium carriers.

Thus, in the instance of the application of a poled ferroelectric ceramic material as a high voltage battery, an external light source would not be required as the ionising source in that the non-equilibrium carriers would be produced by the internal ionisation of the ferroelectric ceramic material effected by the radiation and would result in an emf which would appear across the electrodes.

Accordingly, an open circuit voltage proportional to the length of the ferroelectric ceramic material between the electrodes and inversely proportional to average grain size, and the like as was discussed at the outset of this

specification would be produced by the gamma or X-radiation. Similarly, a short circuit current proportional to the electrode area and the net (steady state) increment of excess carriers introduced into the conduction band would likewise be produced, this being related to the intensity of the ionising radiation.

As can be appreciated, the emf would persist as long as the ionising radiation persisted and, extrapolating from the detailed photo-effect results, the emf produced by this high voltage battery would be relatively independent of the intensity of the radiation and thus not strongly dependent on the half-life of the radioactive material.

While there has been shown and described several preferred embodiments and applications of the basic invention hereof, those skilled in the art should appreciate that such embodiments are exemplary and not limiting and are to be construed within the scope of the following claims:

CLAIMS

1. A photovoltaic memory apparatus comprising: a substrate of a ferroelectric ceramic; means for selectively applying a voltage pulse of a predetermined polarity across a region of said substrate to thereby effect a remanent ferroelectric polarisation in said region of said substrate representative of the information to be stored; means for selectively illuminating said poled region of said substrate with a source of radiation, whereby a photovoltaic voltage is produced at said region of a polarity dependent upon said predetermined polarity of said polarising voltage pulse; and means for detecting said photovoltaic voltage whereby the stored information is retrieved.
2. A memory apparatus as defined in claim 1, wherein an array of electrode pairs are disposed on opposing sides of said substrate to define a matrix configuration of poled regions, said polarising voltage pulse being applied across selected electrode pairs, and wherein said information reading means scans said matrix configuration in accordance with a desired pattern, said detecting means being coupled to said array of electrode pairs and being synchronised with said information reading means.
3. A memory apparatus as defined in claim 1, wherein said substrate is sandwiched between at least one electrode pair and one electrode of said electrode pair is transparent such that said illumination from said information reading means passes through it into said respective poled region of said substrate.
4. A method of addressing and storing information utilising a substrate of a ferroelectric ceramic as a memory core, said method comprising the steps of initially effecting a remanent electrical polarisation in regions of the ferroelectric ceramic by the application of a voltage pulse across the regions of the substrate, the voltage pulse having at least one of a polarity and magnitude representative of the information to be stored; addressing the memory core while illuminating the polarised regions of the ferroelectric ceramic substrate with a source of radiation; and detecting at least one of the polarity and magnitude of the photovoltaic current and voltage produced by such illumination upon the polarised regions, the polarity and magnitude being dependent upon the polarity and magnitude of the initial polarising voltage pulse whereby the stored information is recovered.
5. An optical apparatus comprising in combination: an electro-optic means providing variable light transmission characteristics in response to the magnitude and polarity of an applied voltage; a substrate of a ferroelectric ceramic; means for applying a polarising voltage pulse of a predetermined magnitude and polarity across said substrate to effect a remanent electrical polarisation within said substrate; means for illuminating said electro-optic means and said ceramic substrate, illumination impinging upon said substrate effecting the generation by said substrate of a photovoltaic current and voltage having a polarity dependent upon the polarity of said polarising voltage pulse; and means for applying said generated photovoltaic voltage to said electro-optic means, whereby the transmission characteristics of said electro-optic means to the illumination impinging thereon is varied to effect a visual display.
6. A display apparatus as defined in claim 5, wherein the light transmission characteristics of said electro-optic means is switched from a relatively low opacity to a relatively high opacity upon application thereto of said generated photovoltaic voltage.
7. A display apparatus as defined in claim 5, wherein the light transmission characteristics of said electro-optic means is switched from a relatively high opacity to a relatively low opacity upon application thereto of said generated photovoltaic voltage.
8. A display apparatus as defined in claim 6, wherein said relatively low opacity is of a value such that said electro-optic means is substantially transparent, said relatively high opacity being of a value such that said electro-optic means is substantially opaque.

9. A display apparatus as defined in claim 7, wherein said relatively low opacity is of a value such that said electro-optic means is substantially transparent, said relatively high opacity being of a value such that said electro-optic means is substantially opaque.
10. A display apparatus as defined in claim 5, wherein the magnitude of said polarising voltage is selected such that the light transmission characteristics of said electro-optic means is switched between varying opacities to define a gray scale.
11. A display apparatus as defined in claim 33, wherein said electro-optic means is a liquid crystal of the twisted nematic type.
12. A display apparatus as defined in claim 5, wherein said electro-optic means is a liquid crystal of the colour switching type.
13. A display apparatus as defined in claim 11, wherein said liquid crystal is sandwiched between a light polariser and a light analyser.
14. A display apparatus as defined in claim 5, wherein said electro-optic means and said ferroelectric ceramic substrate are disposed in superposition to define a monolithic structure.
15. A display apparatus as defined in claim 14, wherein said electro-optic means is a colour switching liquid crystal disposed in superposition with said ceramic substrate to define a monolithic structure, and wherein said means for applying a polarising voltage to said substrate and said means for applying said photovoltaic voltage to said liquid crystal comprises a plurality of electrodes disposed on opposite faces of said structure with said structure being sandwiched between them, at least one electrode pair being in contact with said liquid crystal and with said ceramic substrate, respectively; said electrode of said pair which is in contact with said liquid crystal being transparent.
16. A display apparatus as defined in claim 14, wherein said monolithic structure constitutes a plurality of stacked superposed layers comprising a first transparent electrode, an electro-optic means, a second transparent electrode, said substrate of a ferroelectric ceramic, and a third electrode, said third electrode being coupled to said first electrode, said means for applying said polarising voltage being defined by said second and third electrodes, said means for applying said generated photovoltaic voltage being defined by said first and second electrodes, and wherein said means for illuminating said electro-optic means and said substrate comprises a light beam directed to impinge upon said first transparent electrode.
17. A display apparatus as defined in claim 16, wherein said electro-optic means is a liquid crystal of the colour switching type.
18. A display apparatus as defined in claim 16, wherein said plurality of stacked layers further includes a polariser disposed over said first transparent electrode, and an analyser disposed between said second transparent electrode and said ceramic substrate, said electro-optic means being a liquid crystal of the twisted nematic type.
19. A display apparatus as defined in claim 16, wherein said illumination means comprises a source of polarised light, said plurality of stacked layers including an analyser disposed between said second transparent electrode and said ceramic substrate, said electro-optic means being a liquid crystal of the twisted nematic type.
20. A display apparatus as defined in claim 19, wherein said analyser is disposed in a direction parallel to the plane of polarisation of the incident illumination.
21. A display apparatus as defined in claim 19, wherein said analyser is disposed so as to be crossed with respect to the plane of polarisation of the incident illumination.
22. A method of electrically storing optical information comprising the steps of: projecting an image constituting the optical information onto a sandwich of a ferroelectric ceramic backed by a layer of resistive material to form an illumination pattern thereon; applying a voltage pulse across the sandwich whereby varying remanent polarisations within the ferroelectric ceramic are produced in dependence upon the illumination pattern.
23. The method of claim 22, further including the step of reading out the remanent polarisations to thereby extract the stored optical information.

24. A display apparatus as defined in claim 5, wherein said variation of the transmission characteristics of the electro-optic means ensures that illumination continues to impinge upon said substrate to latch said electro-optical means and maintain said transmission variation thereof.
25. A method of electrically storing optical information comprising the steps of: projecting an image constituting the optical information onto a ferroelectric ceramic layer to form an illumination pattern thereon and thereby alter the resistivity of the ceramic layer in accordance with said pattern; applying a voltage pulse across the ceramic whereby varying remanent polarisations within the ferroelectric ceramic are produced in dependence upon the illumination pattern.

METHODS FOR CONTROLLING THE PATH OF MAGNETIC FLUX FROM A PERMANENT MAGNET AND DEVICES INCORPORATING THE SAME

This patent covers a device which is claimed to have a greater output power than the input power required to run it.

ABSTRACT

A permanent magnet device includes a permanent magnet having north and south pole faces with a first pole piece positioned adjacent one pole face thereof and a second pole piece positioned adjacent the other pole face thereof so as to create at least two potential magnetic flux paths. A first control coil is positioned along one flux path and a second control coil is positioned along the other flux path, each coil being connected to a control circuit for controlling the energisation thereof. The control coils may be energised in a variety of ways to achieved desirable motive and static devices, including linear reciprocating devices, linear motion devices, rotary motion devices and power conversion.

DESCRIPTION

FIELD OF THE INVENTION

This invention relates generally to permanent magnet devices and more particularly, to a permanent magnet control component in which the flow of flux from a permanent magnet is controlled between two or more flux paths by utilising timed delivery of electrical signals through one or more coils placed along at least one of the flux paths. Such permanent magnet control components may take on a variety of configurations facilitating use of such components in a variety of applications including applications involving the production of reciprocating, linear, and rotary motion and power conversion. Several novel permanent magnet rotary motion devices of motor constructions which operate by controlling the path of magnetic flux from one or more permanent magnets are described, such permanent magnet rotary motor constructions having increased efficiency and more desirable torque characteristics as compared to many currently used motors.

BACKGROUND OF THE INVENTION

Magnetic force of attraction is commonly used in a variety of types of permanent magnet devices including both linear and rotary motors. In the field of such permanent magnet devices there is a continuous pursuit of increased efficiency and reduced complexity.

Accordingly, an object of the present invention is to provide a permanent magnet control component in which the path of a given level of permanent magnet flux can be controlled by a lesser level of electromagnetic flux.

Another object of the present invention is to provide a permanent magnet control component in which substantially all of the flux from a permanent magnet can be switched between at least two different flux paths of the permanent magnet control component so as to enable useful work in the form of linear, reciprocating, and rotary motion.

Still another object of the present invention is to provide permanent magnet control components and motor constructions in which flux path control is provided by energising an 10 electromagnet to oppose the magnetic flux of one or more permanent magnets.

Another object of the present invention is to provide permanent magnet control components and motor constructions in which flux path control is provided by energising an electromagnet to aid the magnetic flux of one or more permanent magnets.

Yet another object of the present invention is to provide permanent magnet motor 15 constructions with improved operating characteristics.

SUMMARY OF THE INVENTION

These and other objects of the invention are attained by an apparatus which, in one aspect, is a permanent magnet device, comprising a permanent magnet having north and south pole faces, a first pole piece, a second pole piece, a first control coil, a second control coil, and circuit means, the first pole piece positioned adjacent the north pole face of the permanent magnet and including a first path portion, a second path portion and a third portion, the first path portion extending beyond a perimeter of the north pole face and the second path portion extending beyond the perimeter of the north pole face to define first and second flux paths for magnetic flux emanating from the north pole face of the permanent magnet, the first path portion of the first pole piece connected to the second path portion of the first pole piece by the third portion which extends across the north pole face of the permanent magnet, the second pole piece positioned adjacent the south pole face and including a first path portion and a second path portion, the first path portion extending beyond a perimeter of the south pole face and substantially aligned with the first path portion of the first pole piece, the second path portion extending beyond the perimeter of the south pole face and substantially aligned with the second path portion of the first pole piece, the first control coil positioned around the first path portion of the first pole piece, the second control coil positioned around the second path portion of the first pole piece, the circuit means connected to each of the first control coil and the second control coil to alternately energise the first coil and the second coil in a timed sequential manner.

Another aspect of the present invention provides a method for controlling the path of magnetic flux from a permanent magnet which involves placing a first pole piece adjacent a first pole face of the permanent magnet so as to have at least first and second path portions extending beyond a perimeter of the first pole face. A second pole piece is placed adjacent a second pole face of the permanent magnet so as to include at least one portion which substantially aligns with the first and second path portions of the first pole piece. A first control coil is placed along and around the first path portion of the first pole piece and a second control coil is placed along and around the second path portion of the first pole piece. The first control coil is repeatedly energised in a permanent magnet magnetic flux opposing manner so as to prevent magnetic flux of the permanent magnet from traversing the first path portion of the first pole piece, and the second control coil is repeatedly energised in a permanent magnet magnetic flux opposing manner so as to prevent magnetic flux of the permanent magnet from traversing the second path portion of the first pole piece.

Yet another aspect of the present invention provides a method for controlling the path of magnetic flux from a permanent magnet by placing a first pole piece adjacent a first pole face of the permanent magnet so as to have at least first and second path portions extending beyond a perimeter of the first pole face. A second pole piece is placed adjacent a second pole face of the permanent magnet so as to include at least one portion which substantially aligns with the first and second path portions of the first pole piece. A first control coil is placed along and around the first path portion of the first pole piece, and a second control coil is placed along and around the second path portion of the first pole piece. The following steps are alternately performed in a repeated manner:

- (i) energising the first control coil in a permanent magnet magnetic flux aiding manner so as to couple with substantially all magnetic flux of the permanent magnet such that substantially no magnetic flux of the permanent magnet traverses the second path portion of the first pole piece when the first control coil is so energised; and
- (ii) energising the second control coil in a permanent magnet magnetic flux opposing manner so as to couple with substantially all magnetic flux of the permanent magnet such that substantially no magnetic flux of the permanent magnet traverses the first path portion of the first pole piece when the second control coil is so energised.

A further aspect of the present invention provides method for controlling the path of magnetic flux from a permanent magnet by placing a first pole piece adjacent a first pole face of the permanent magnet so as to have at least first and second path portions extending beyond a perimeter of the first pole face, and placing a second pole piece adjacent a second pole face of the permanent magnet so as to include at least one portion which substantially aligns with the first and second path portions of the first pole piece. A first control coil is placed along and around the first path portion of the first pole piece, and a second control coil is placed along and around the second path portion of the first pole piece. The following steps are alternately performed in a repeated manner:

- (i) energising the first control coil in a permanent magnet magnetic flux aiding manner so as to couple with substantially all magnetic flux of the permanent magnet such that substantially no magnetic flux of the permanent magnet traverses the second path portion of the first pole piece when the first control coil is so energised; and
- (ii) energising the second control coil in a permanent magnet magnetic flux opposing manner so as to couple with substantially all magnetic flux of the permanent magnet such that substantially no magnetic flux of the permanent magnet traverses the first path portion of the first pole piece when the second control coil is so energised.

BRIEF DESCRIPTION OF THE INVENTION

For a better understanding of the present invention reference may be made to the accompanying drawings in which:

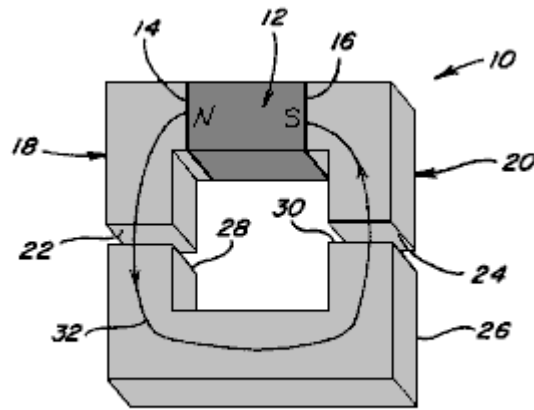

Fig. 1

Fig.1 is a perspective view of a magnetic device in which the magnetic flux from a magnetic member traverse a single path to produce a coupling force;

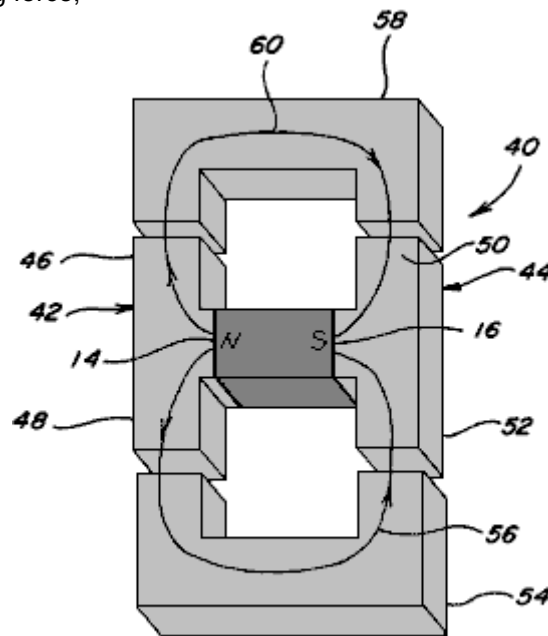

Fig. 2

Fig.2 is a perspective view of a magnetic device in which the magnetic flux from a magnetic member splits between two paths;

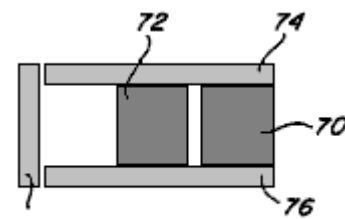

Fig. 3

Fig.3 is a side view of two magnetic members arrange in parallel between pole pieces;

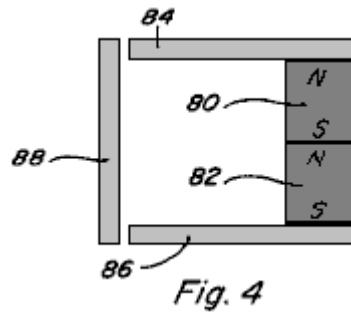

Fig.4 is a side view of two magnetic members arranged in series between pole pieces;

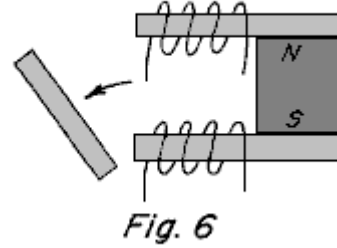
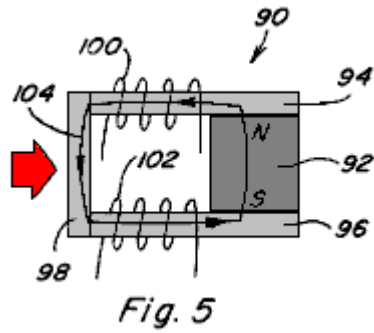

Fig.5 and **Fig.6** are side views of a permanent magnet device including a permanent magnet having pole pieces positioned against the pole faces thereof and including a movable armature;

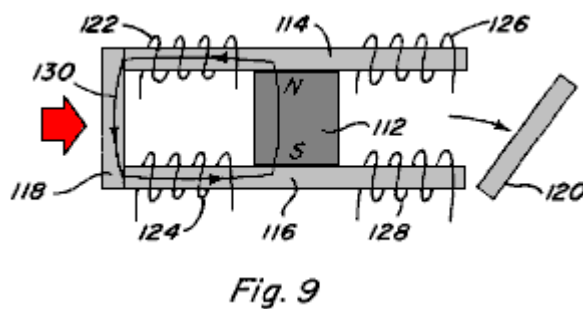
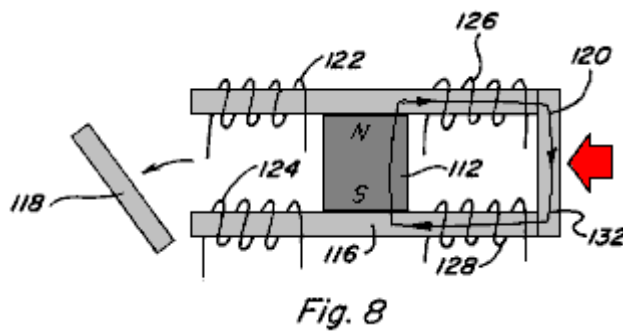
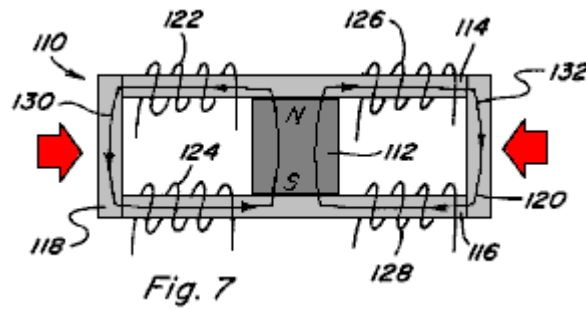

Fig.7, Fig.8 and Fig.9 are side views of a permanent magnet device including a permanent magnet having pole pieces positioned against the pole faces thereof to provide two magnetic flux paths and including a movable armature which can be positioned along each magnetic flux path;

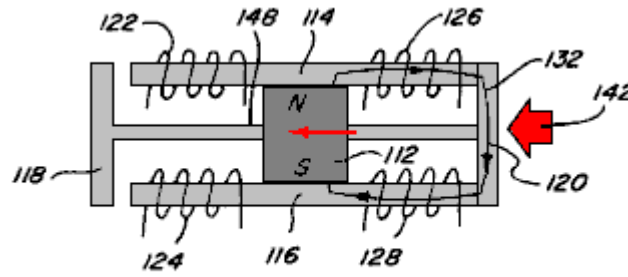

Fig. 10

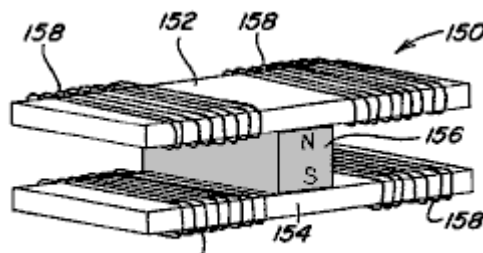

Fig. 10 A

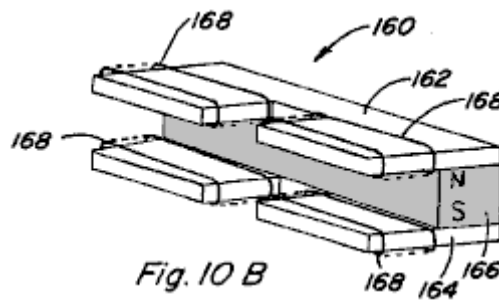

Fig. 10 B

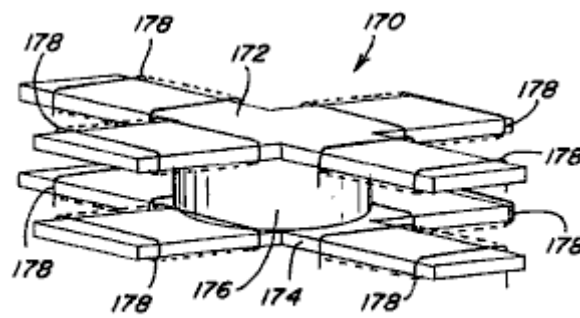

Fig. 10 C

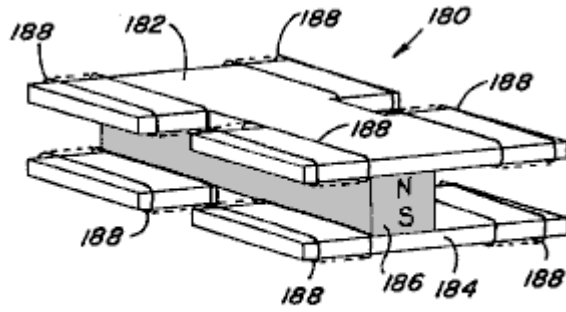

Fig. 10D

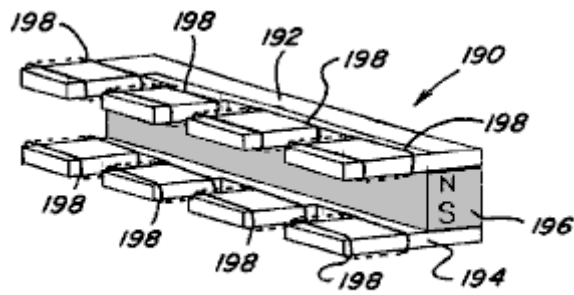

Fig. 10E

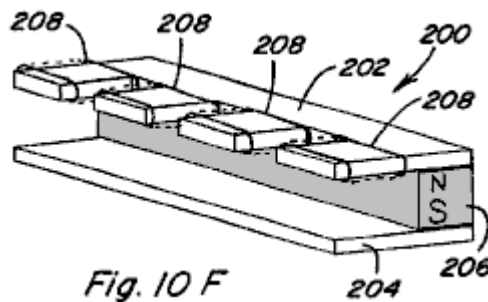

Fig. 10F

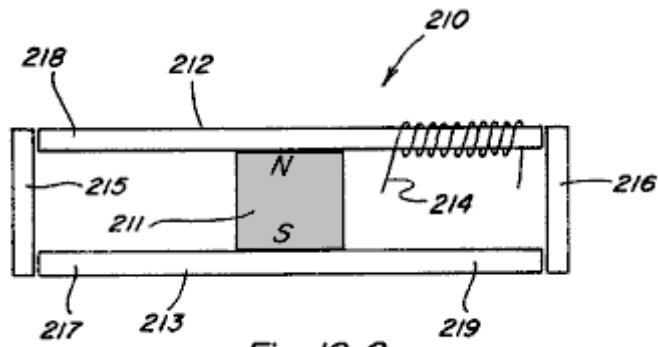

Fig. 10G

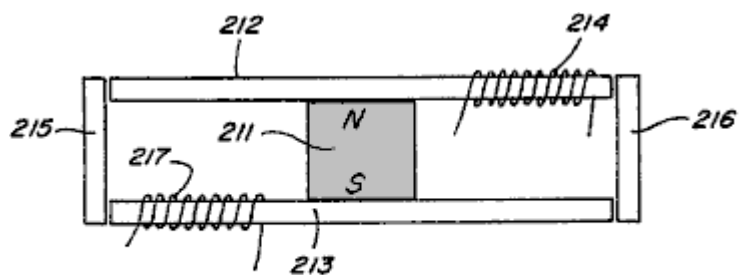

Fig. 10H

Figs.10, 10A-10H are perspective views of various embodiments of permanent magnet 5 control components which include two or more magnetic flux paths;

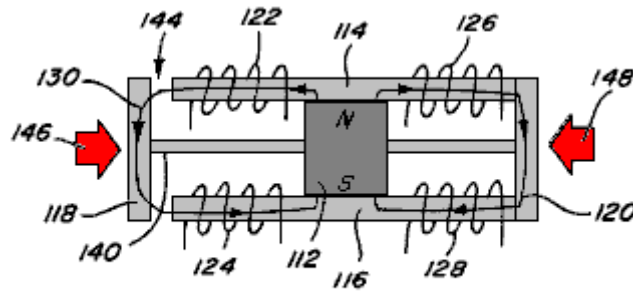

Fig. 11

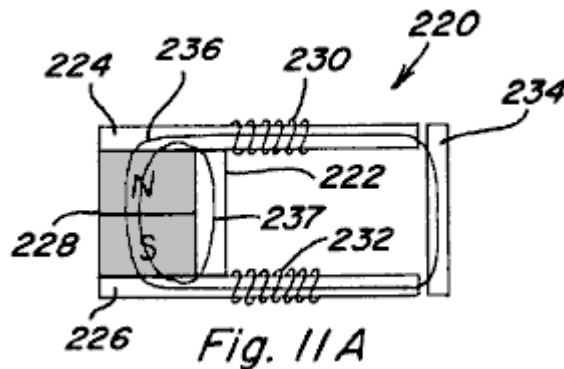

Fig. 11A

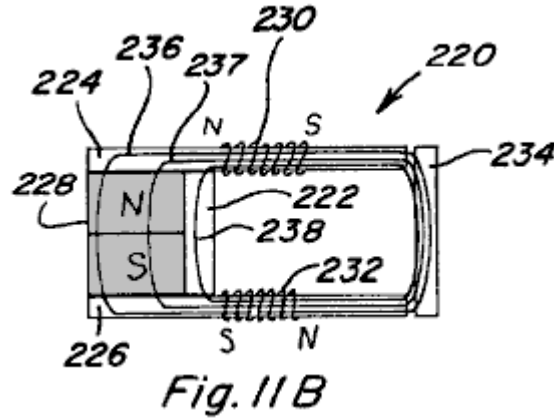

Fig. 11B

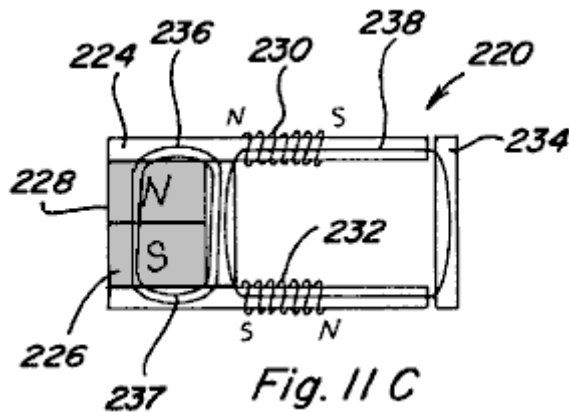
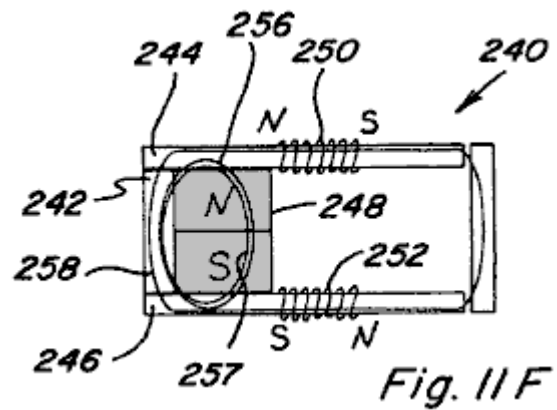
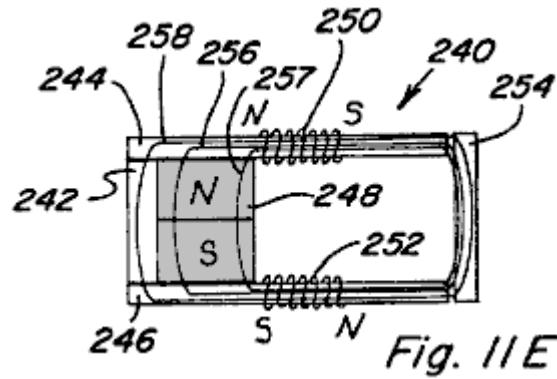
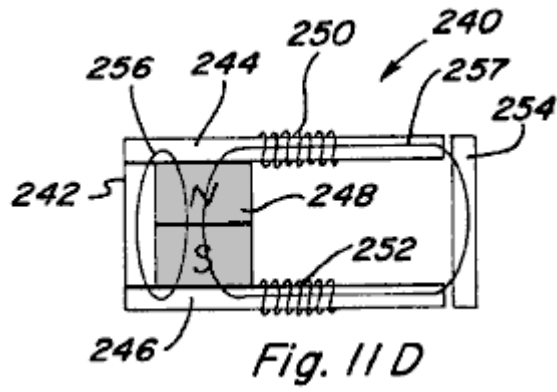
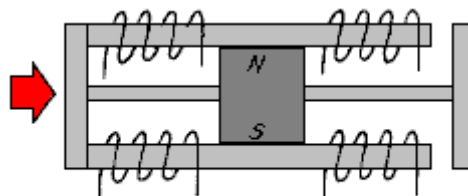
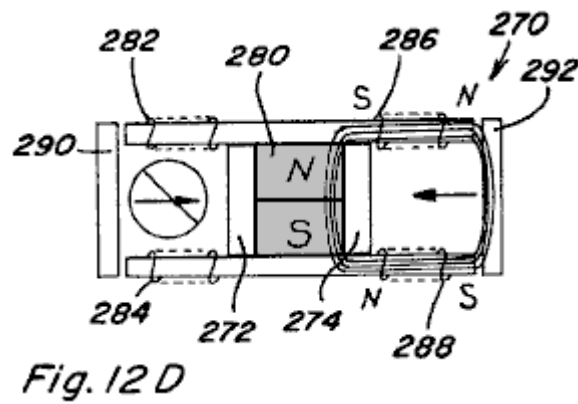
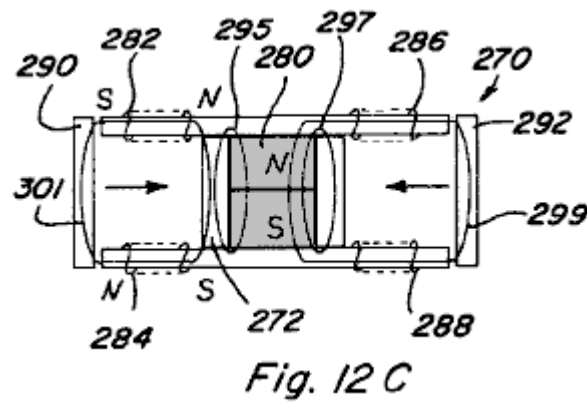
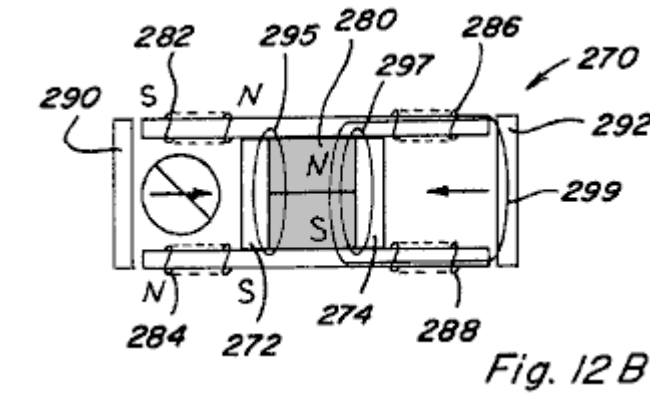
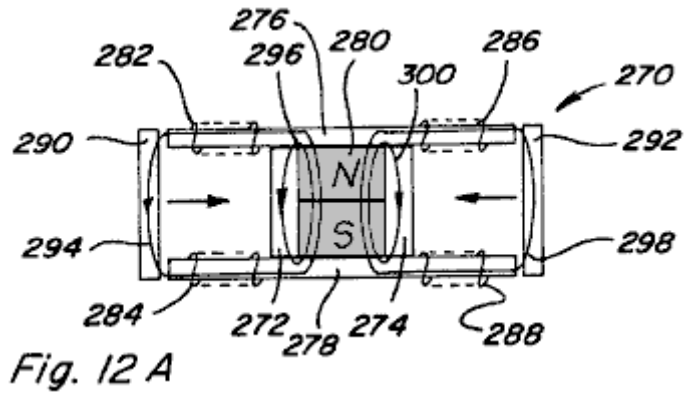

Fig. 11C



Figs.11, 11A-11F are side views of a permanent magnet device including a permanent magnet having pole pieces positioned against the pole faces thereof and including a movable armature and a permanent bypass extending between the pole pieces;





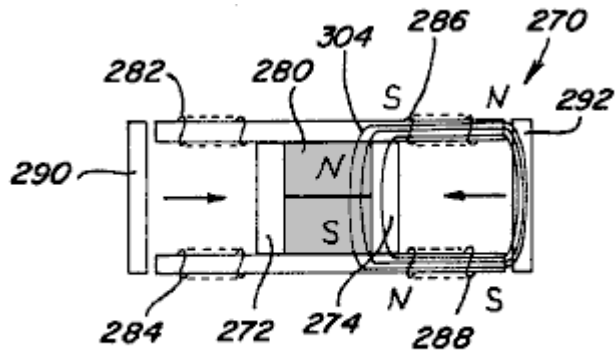

Fig. 12 E

Figs.12, 12A-12E are side views of a two path permanent magnet device including two bypasses;

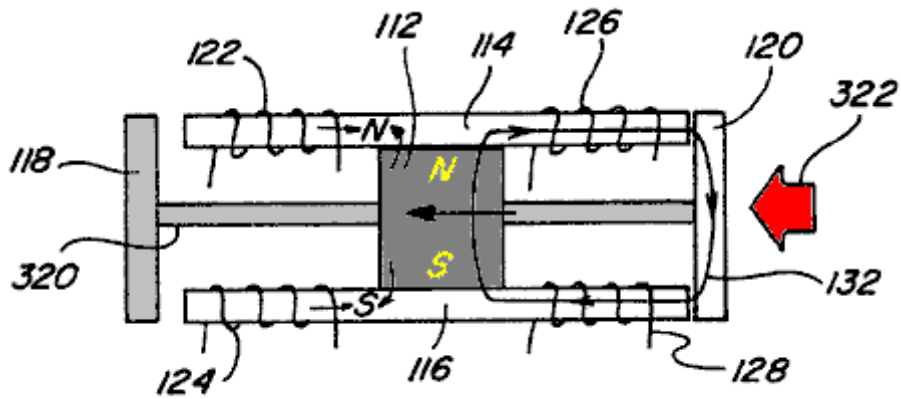

Fig. 13 A

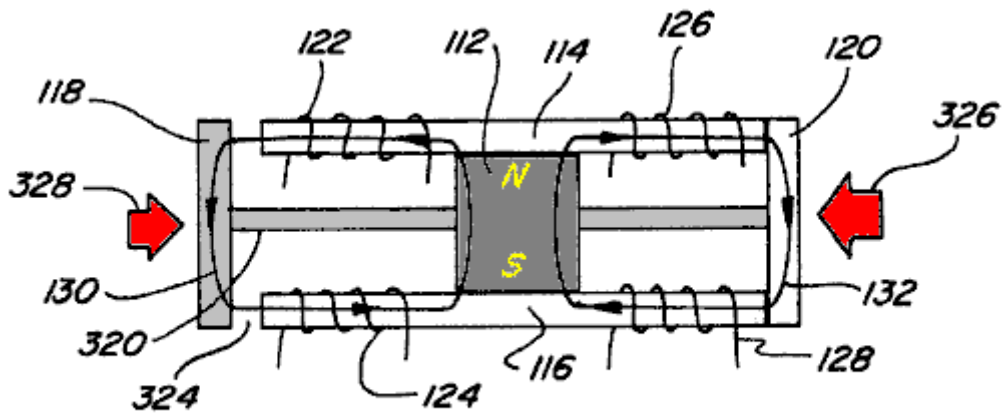
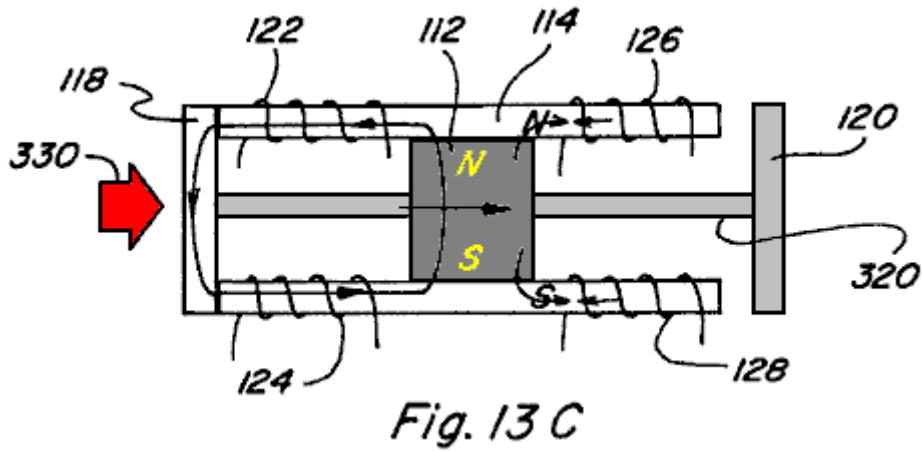

Fig. 13 B



Figs.13A-13C are side views of a permanent magnet linear reciprocating device;

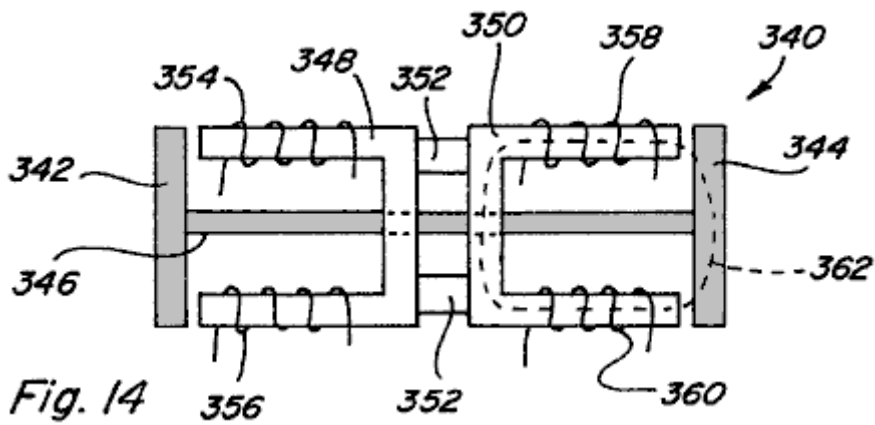

Fig.14 is a side view of an electromagnetic linear reciprocating device;

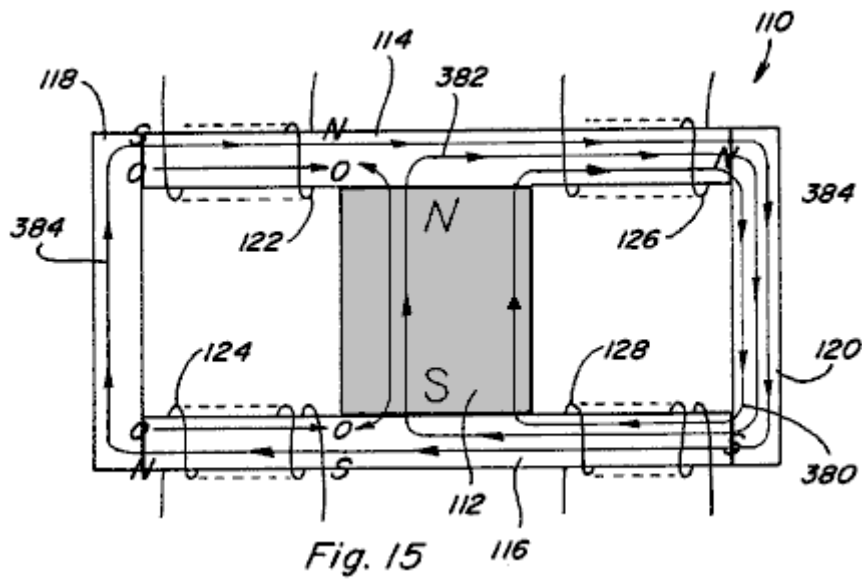

Fig.15 is a side view of a two path permanent magnet device showing control coils energised in an exceeding manner;

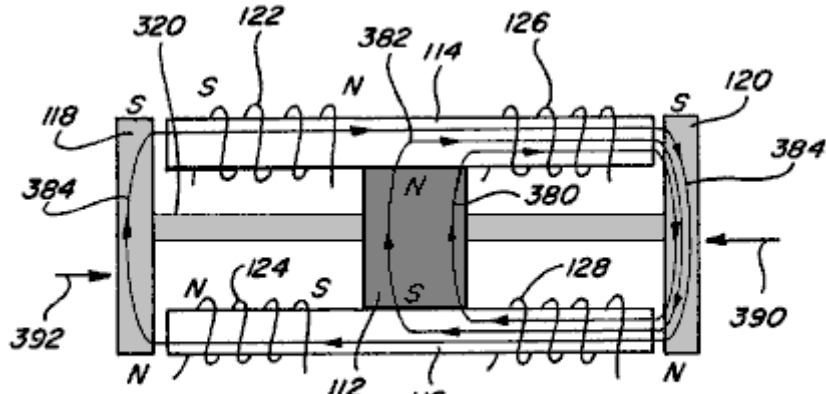

Fig. 16 A

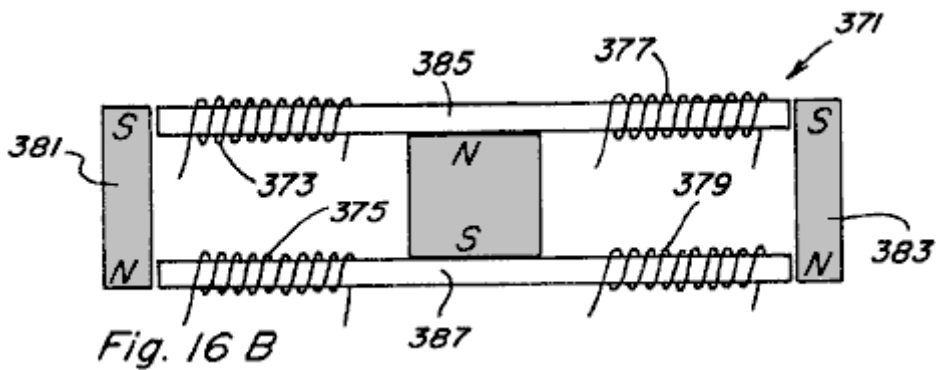

Fig. 16 B

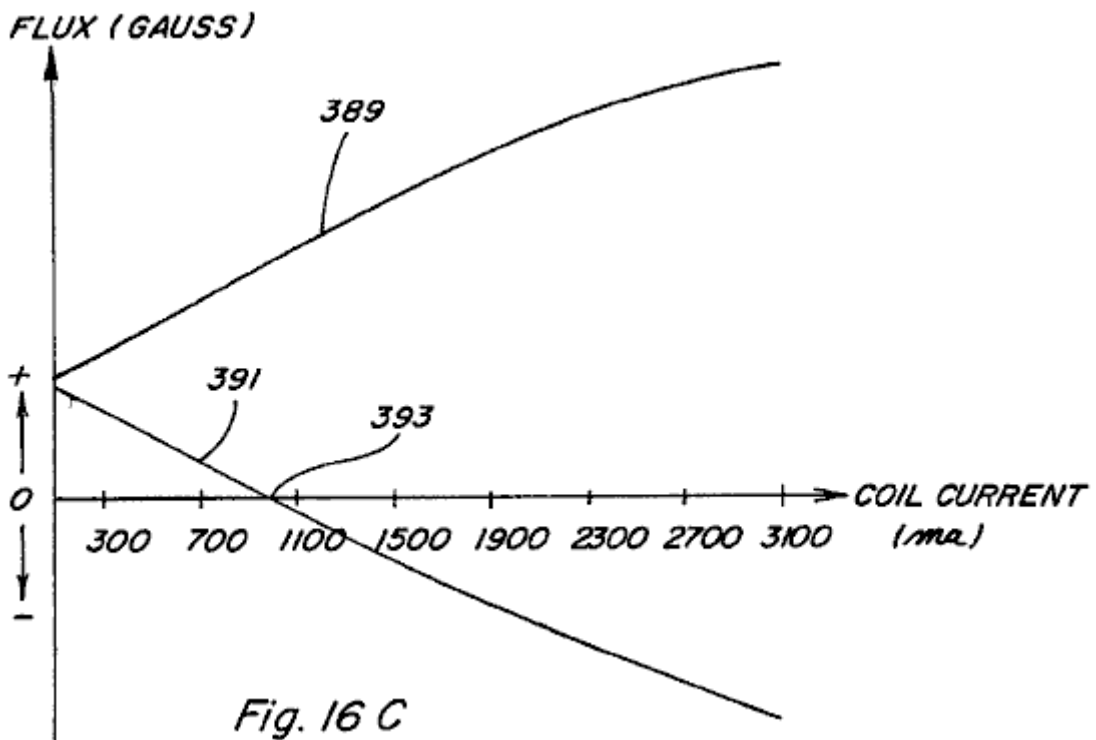
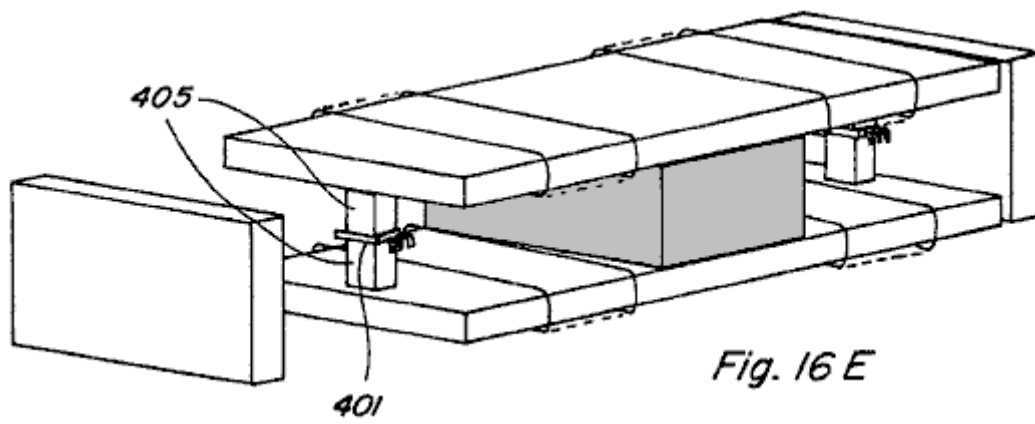
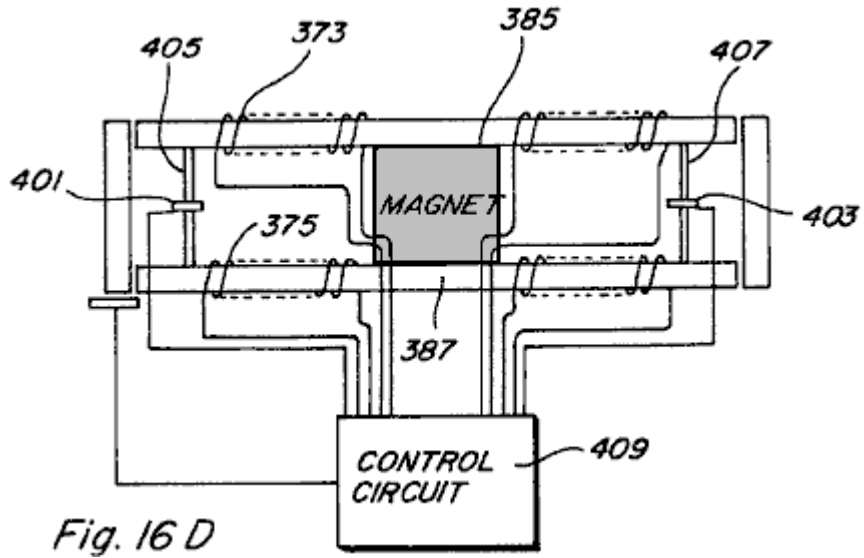
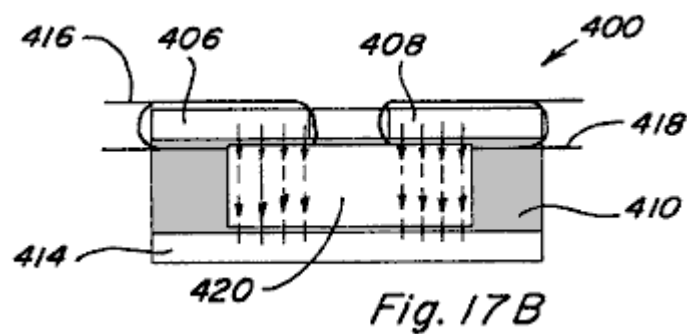
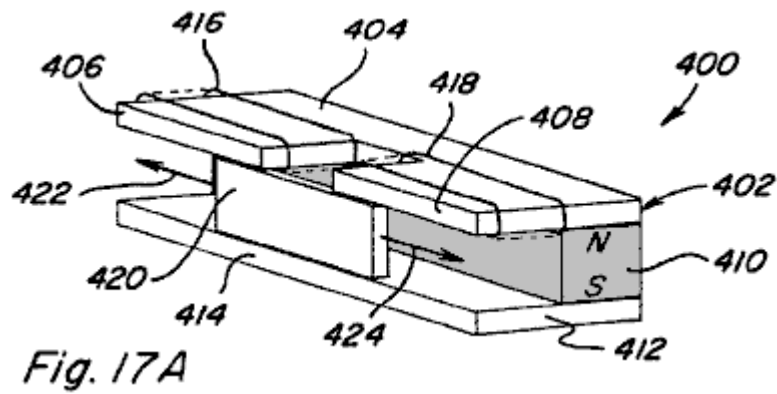

Fig. 16 C



Figs.16A-E are a side view of a linear reciprocating device with control coils energised in an exceeding manner;



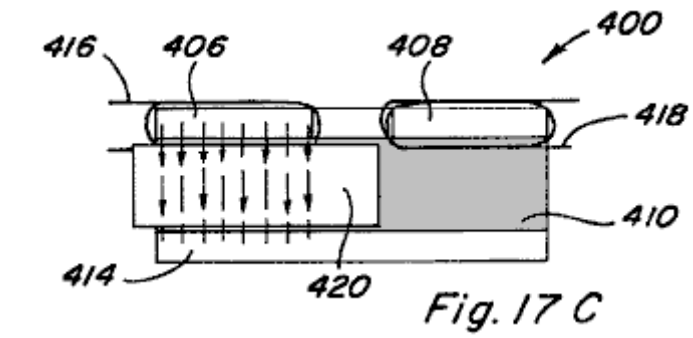

Fig. 17 C

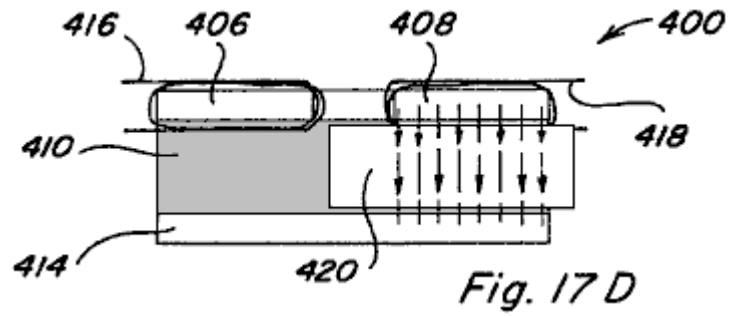

Fig. 17 D

Figs.17A-17D depict another embodiment of a linear reciprocating device;

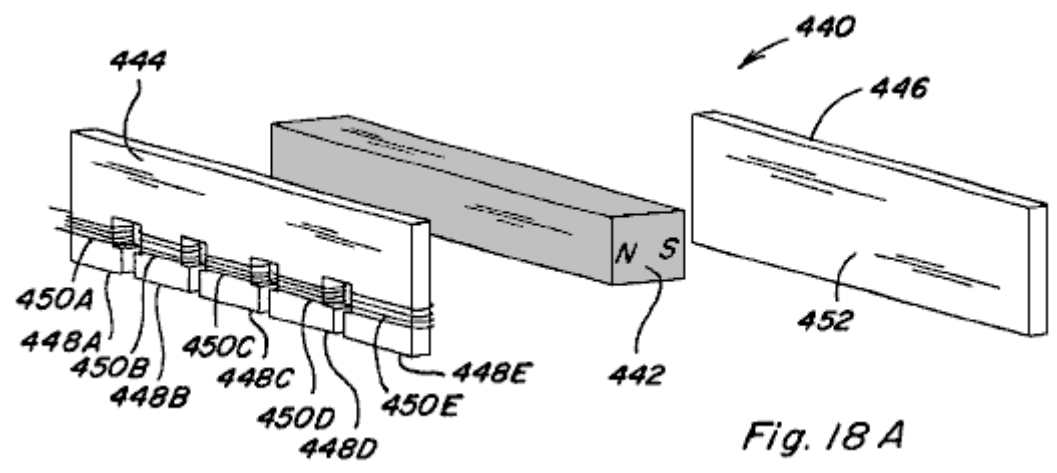

Fig. 18 A

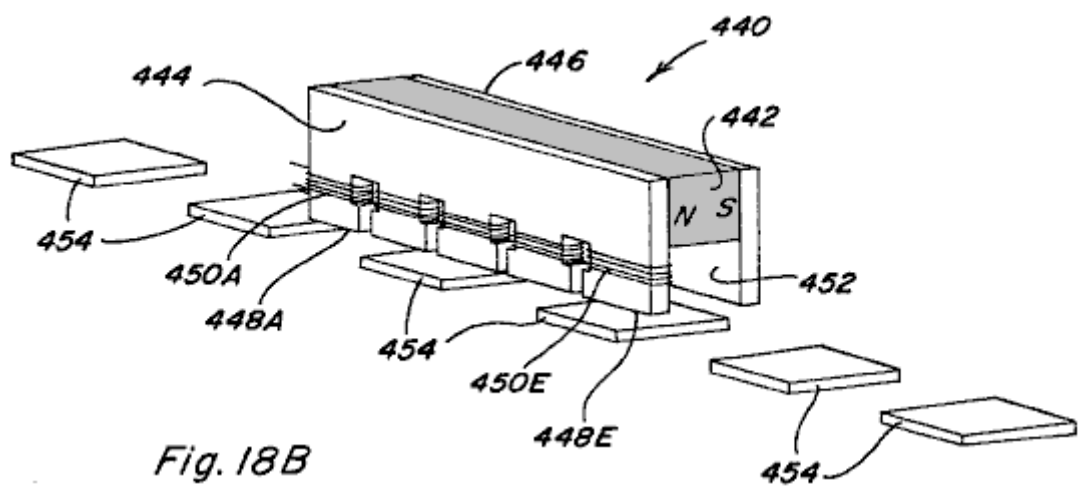
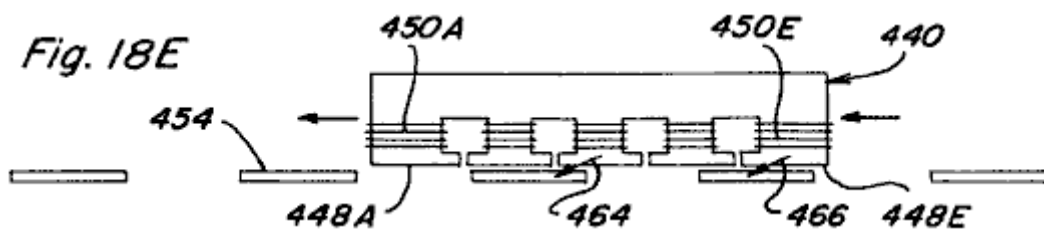
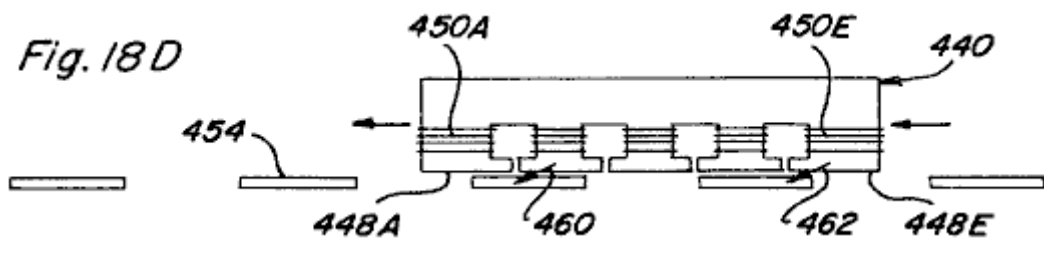
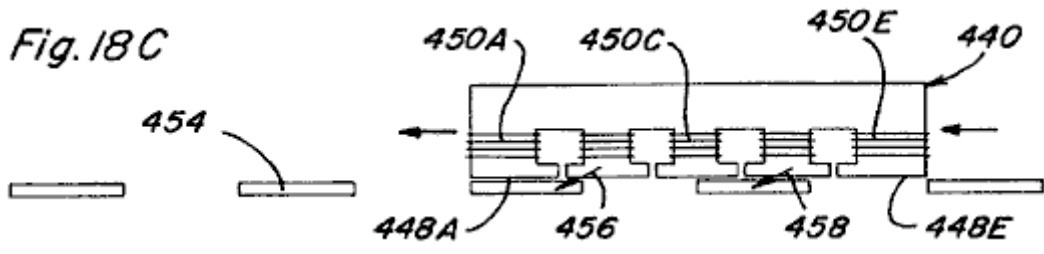

Fig. 18 B



Figs.18A-18E show a linear motion device;

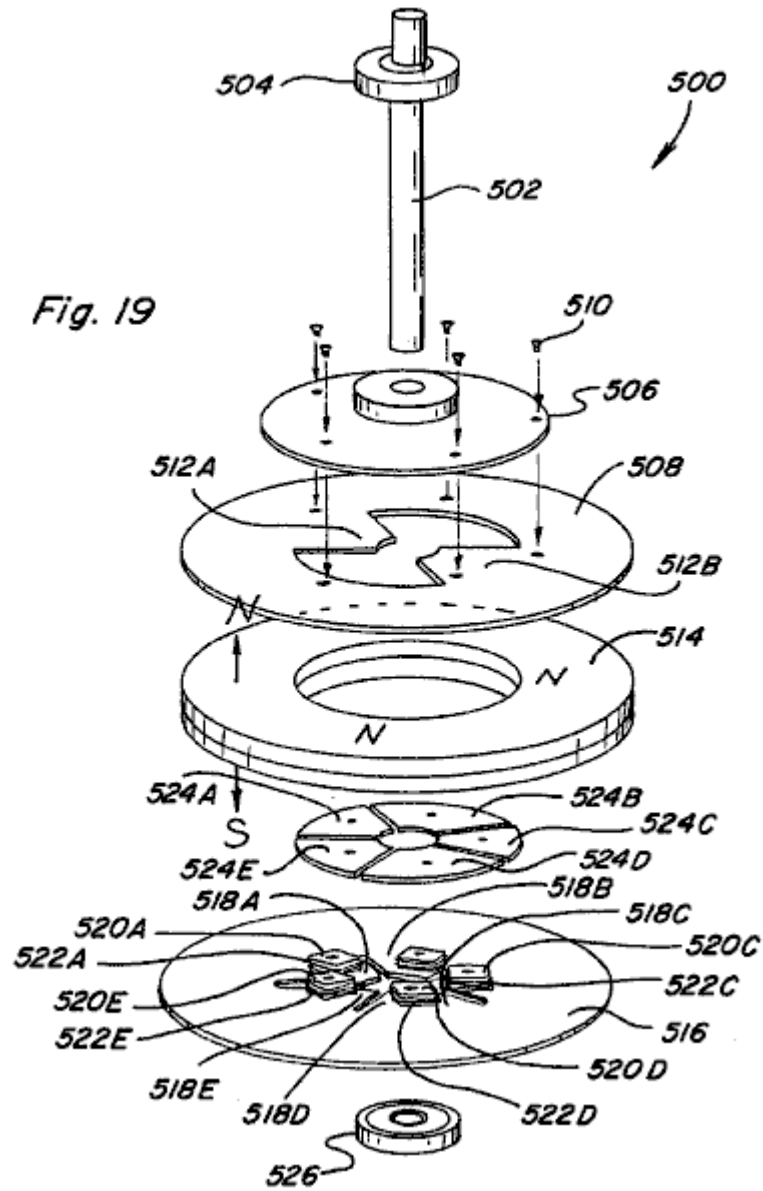

Fig.19 is an exploded perspective view of a rotary motion device;

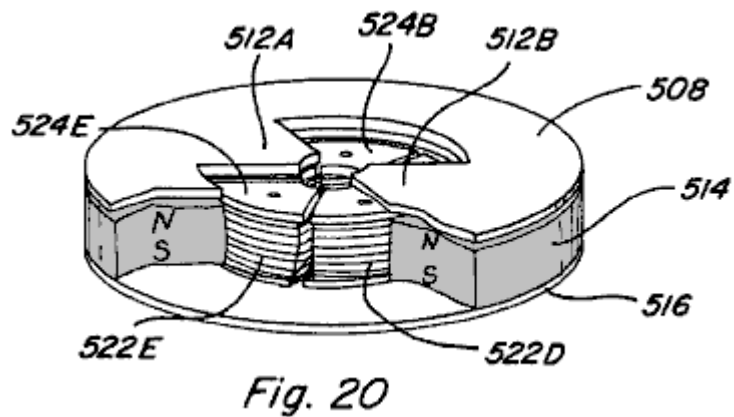
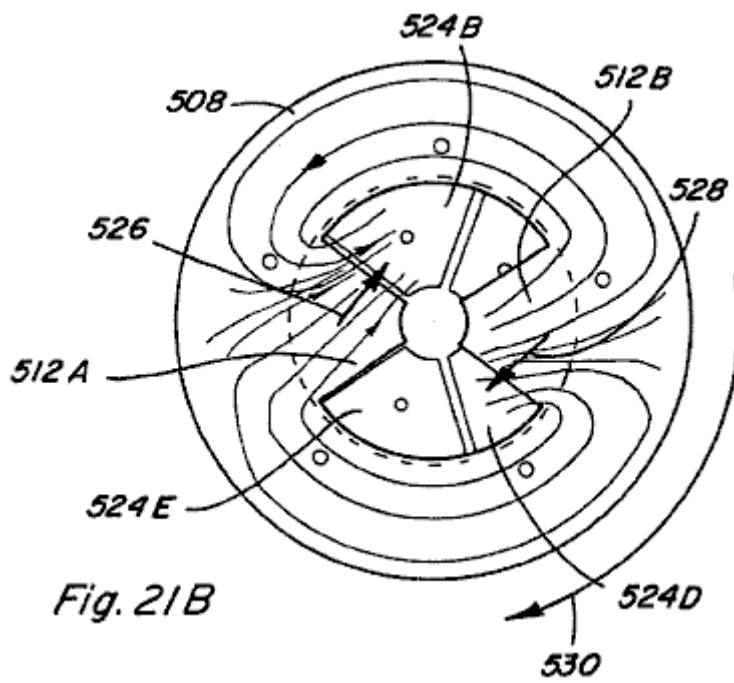
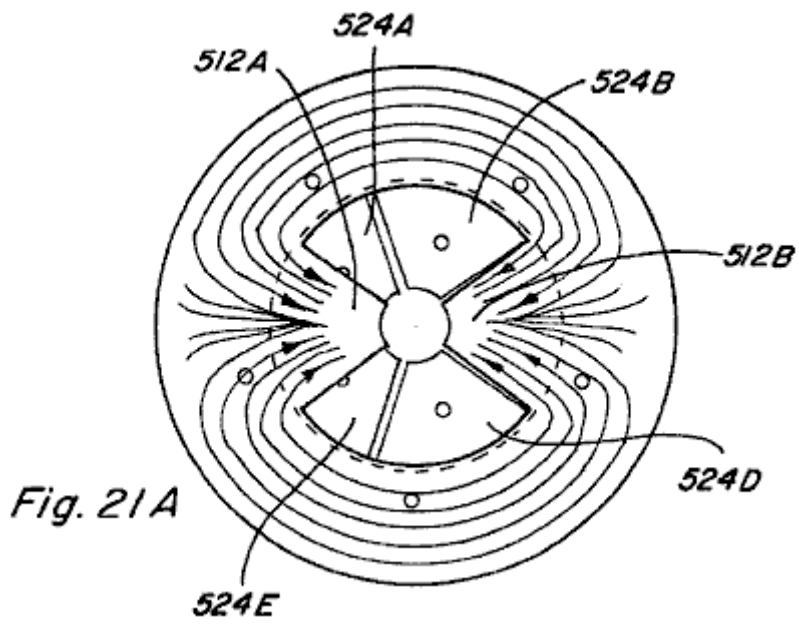
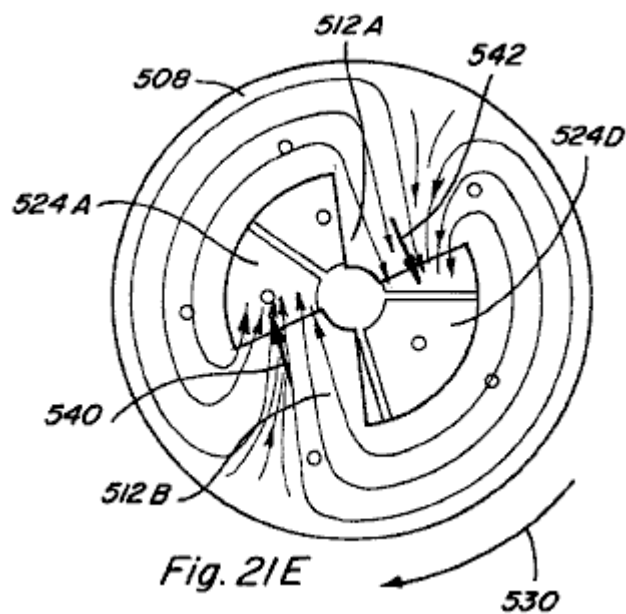
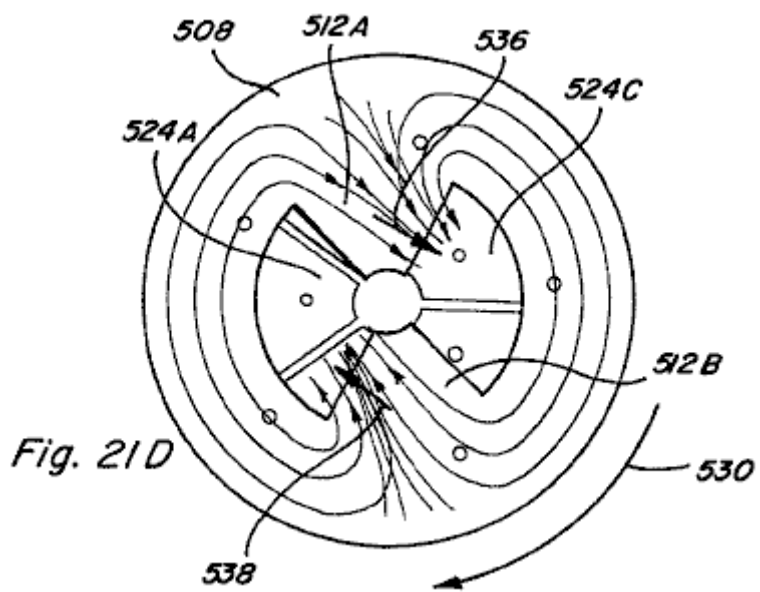
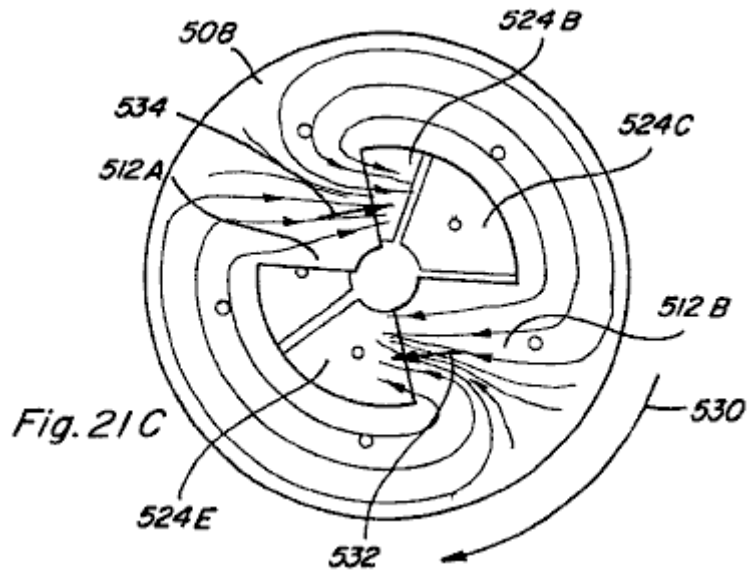

Fig. 20

Fig.20 is a partial assembled and cut away view of the rotary motion device of Fig.19;





Figs.21A-21E are top views of the partial assembly of Fig.20, which views depict rotational motion thereof,

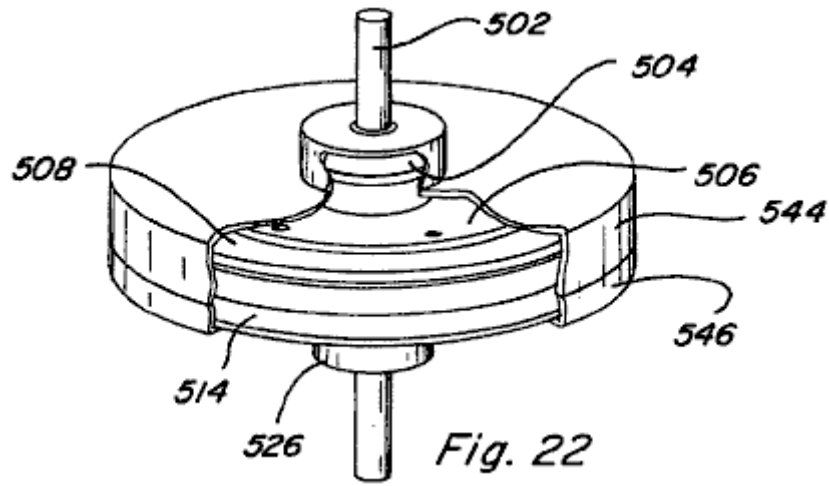

Fig.22 is an assembled, cut-away view of the rotary motion device of Fig.19 including a housing;

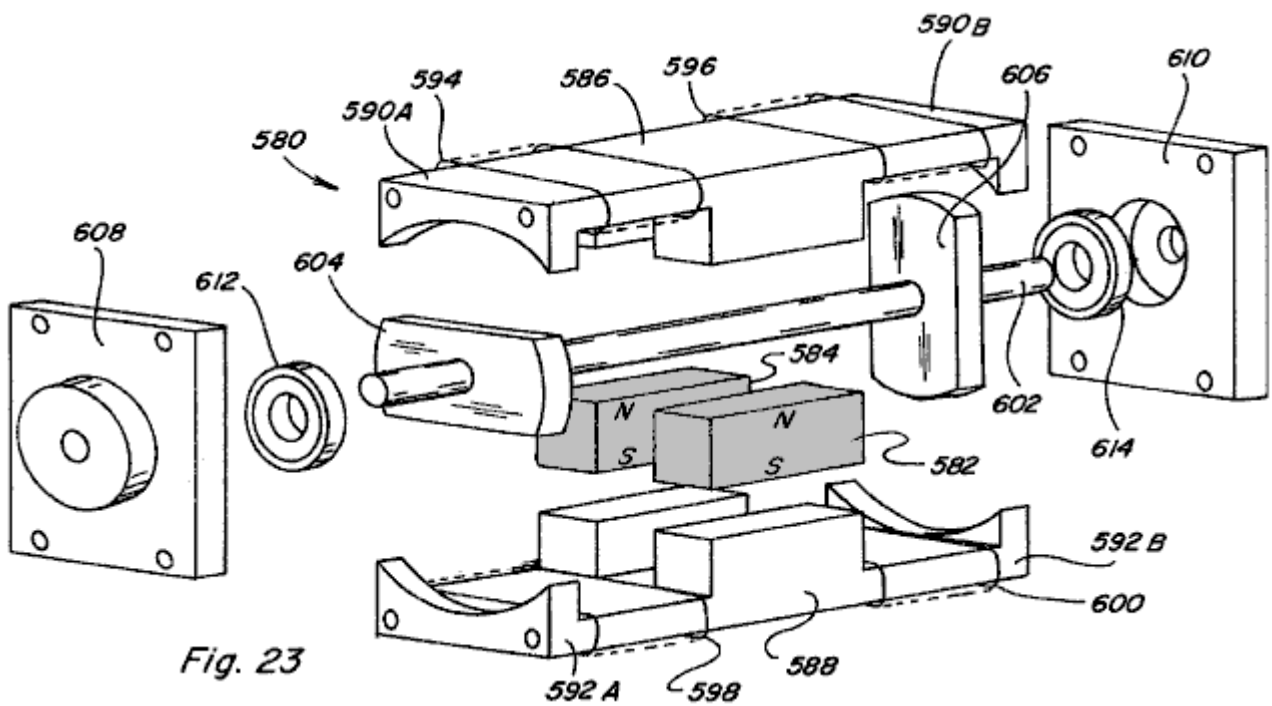

Fig.23 is an exploded perspective view of another embodiment of a rotary motion device;

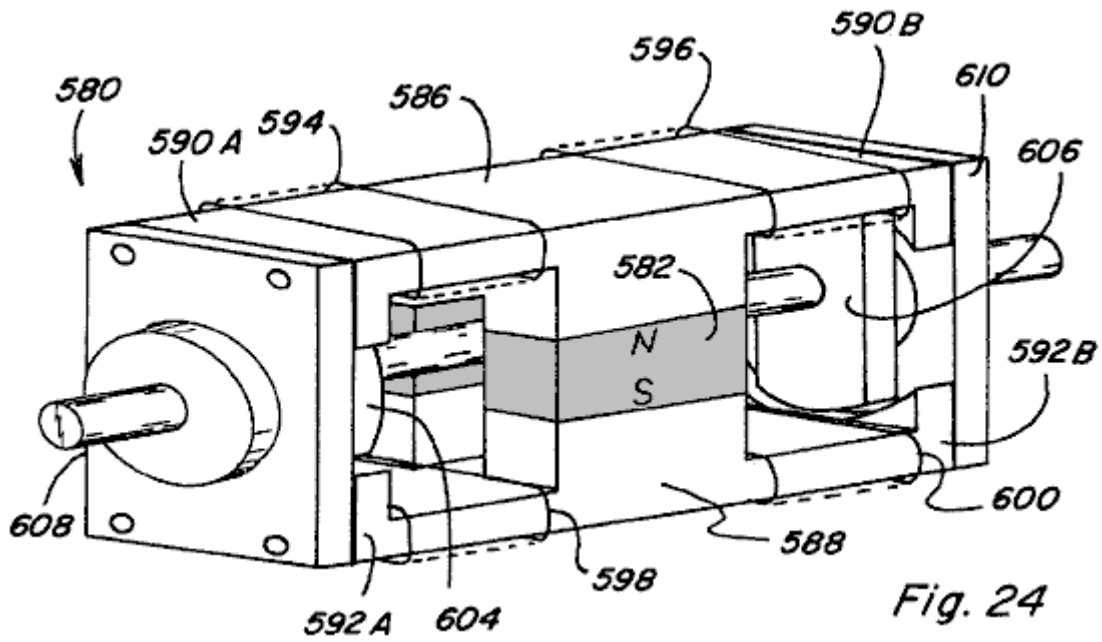
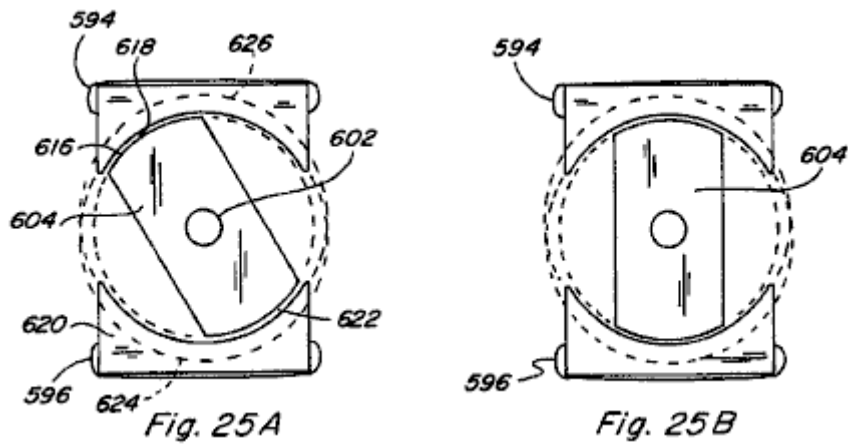
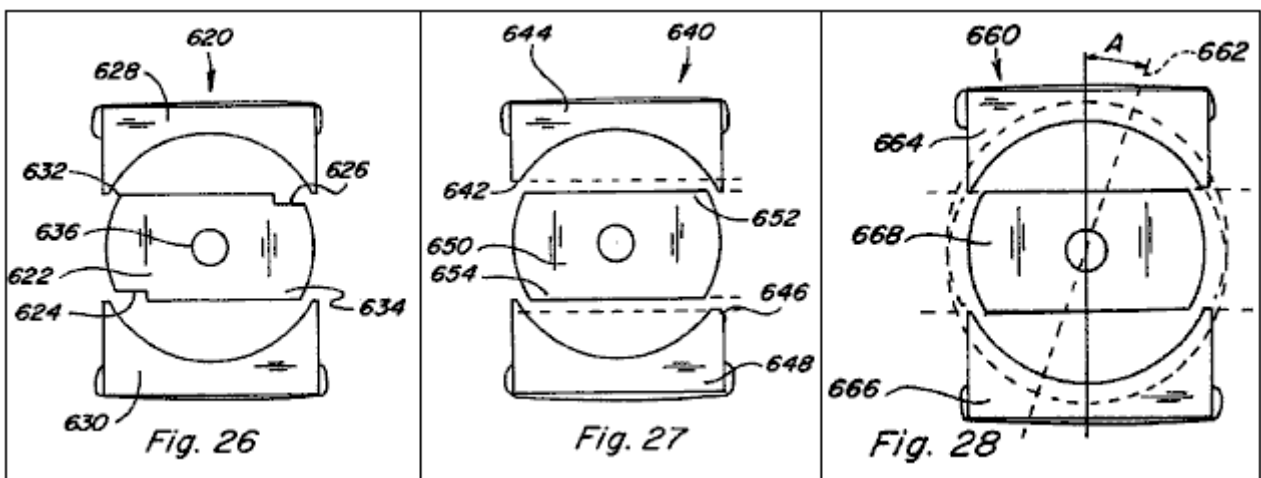

Fig.24 is a perspective view of the rotary motion device of Fig.23 as assembled;



Figs.25A-25B are end views of the rotary motion device of Fig.24 with the end cap removed to expose the rotor member;



Figs.26-28 show end views of various configurations for skewing the direction of rotation in the rotary motion device of Fig.24;

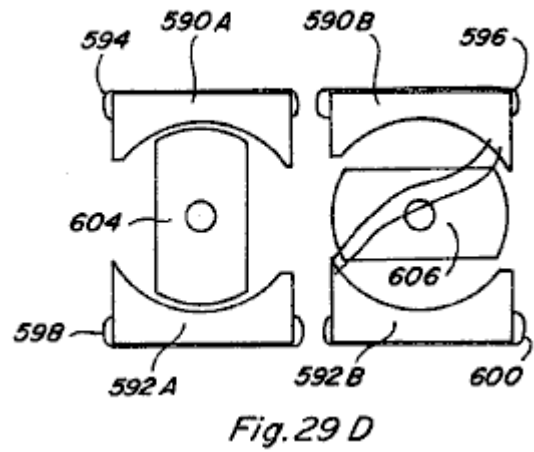
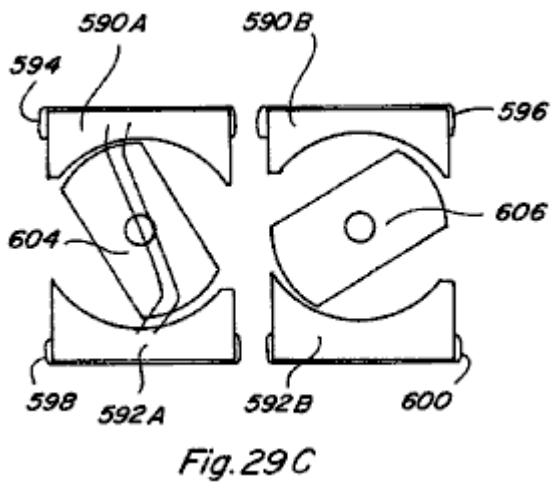
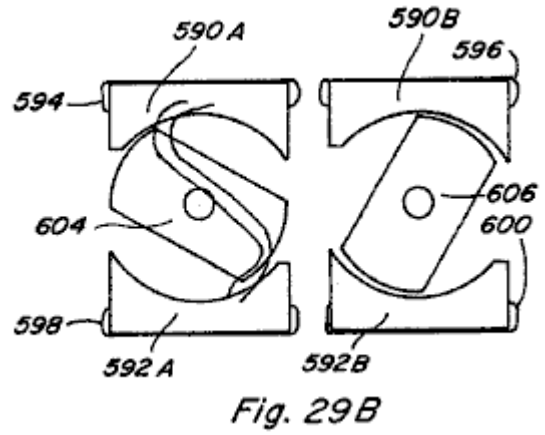
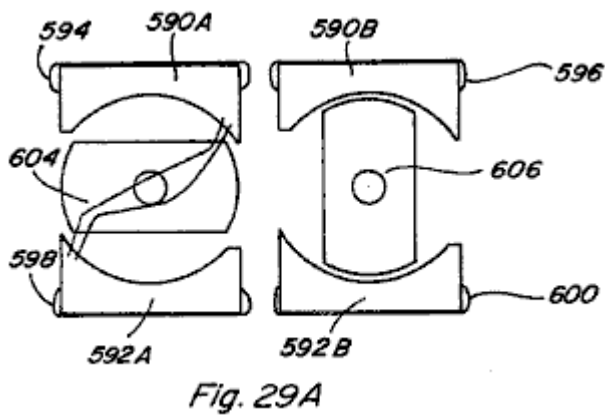

Figs.29A-29D are end views of the rotary motion device of Fig.24 illustrating a sequence of its rotational movements;

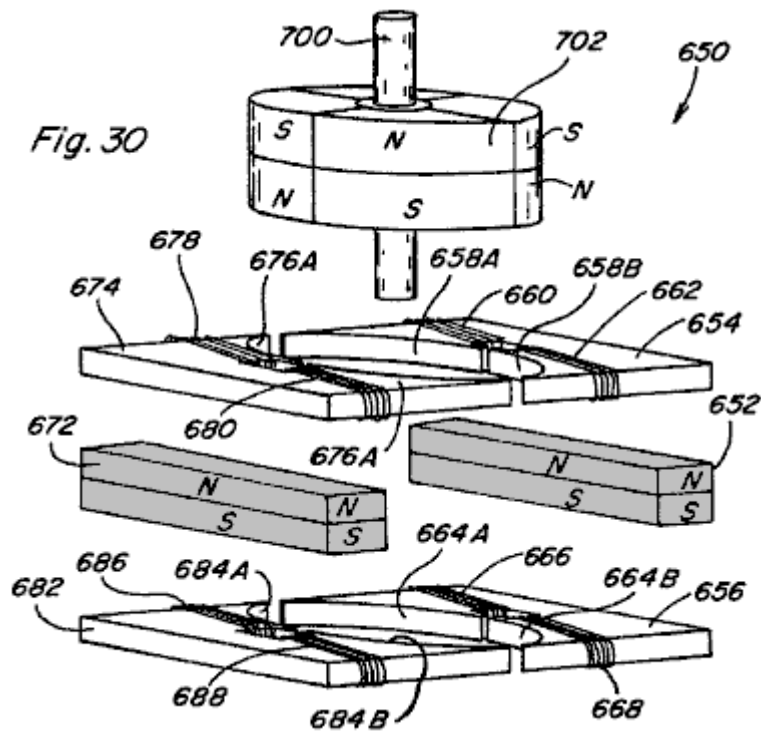

Fig.30 is an exploded partial perspective view of another embodiment of a rotary motion device;

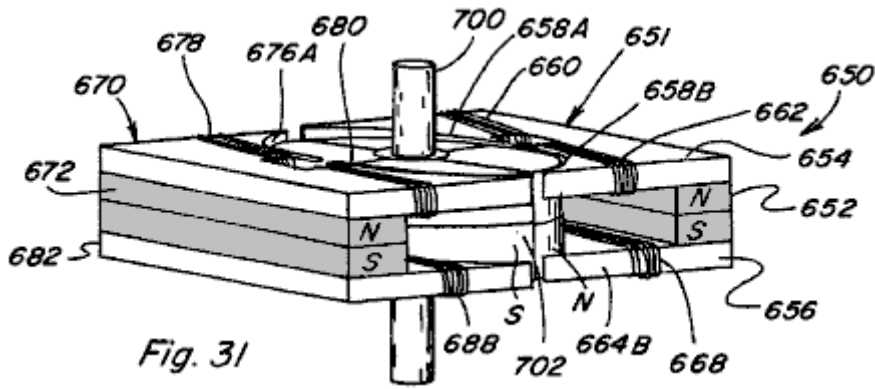

Fig. 31

Fig.31 is a perspective view of the rotary motion device of Fig.30 as assembled

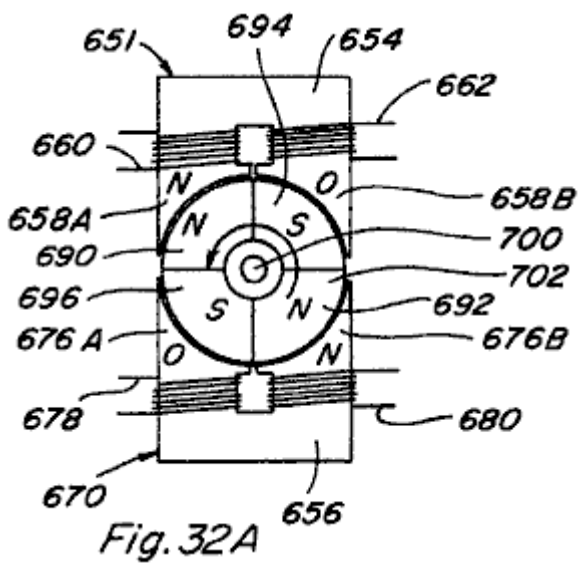

Fig. 32A

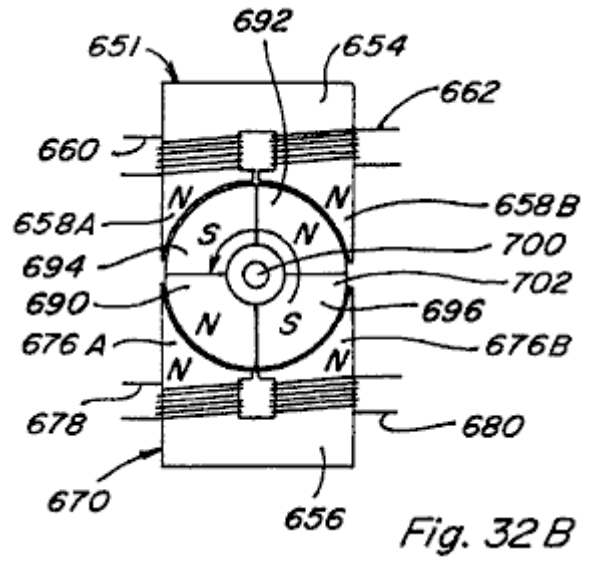

Fig. 32B

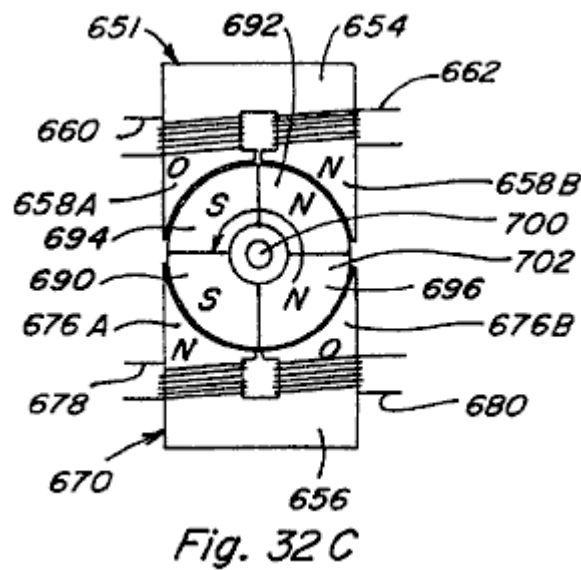

Fig. 32C

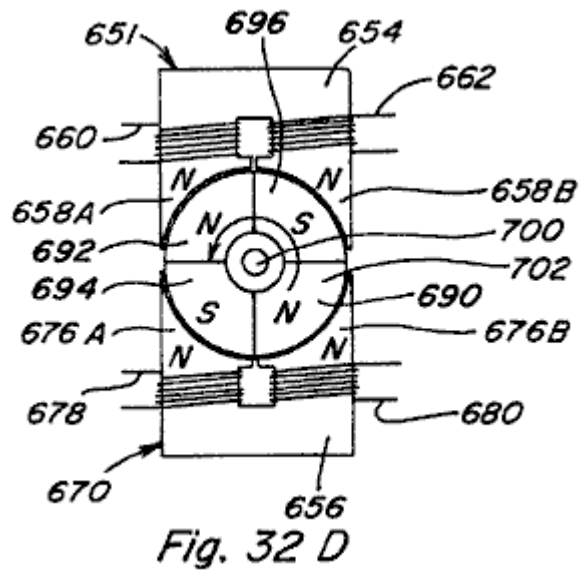

Fig. 32D

Figs.32A-32D are top views of the rotary motion device of Fig.31 illustrating it's rotational movement;

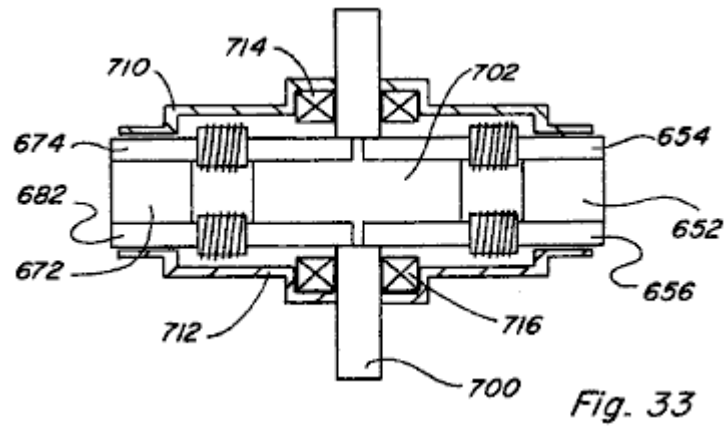

Fig.33 is a side view of the rotary motion device of Fig.31 as assembled and including a housing;

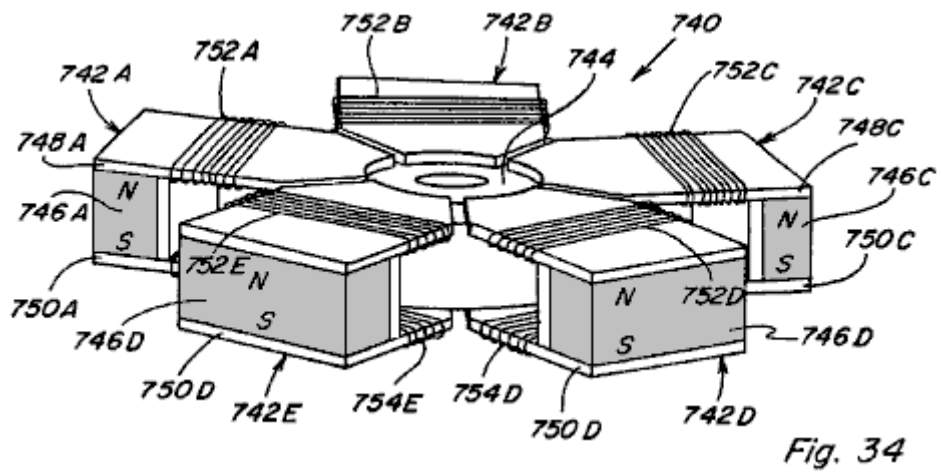

Fig.34 is a perspective view of another embodiment of a rotary motion device;

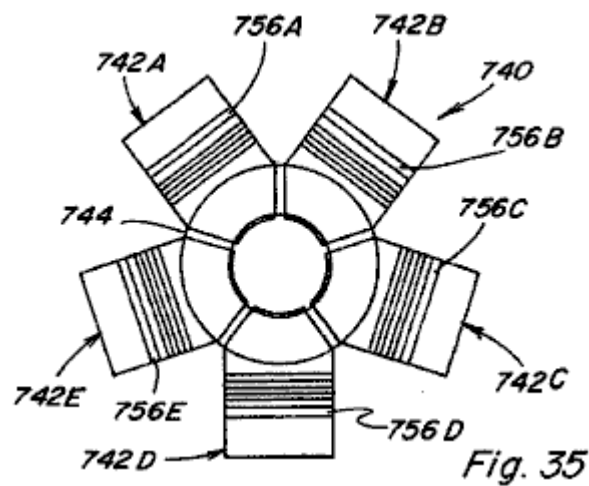

Fig.35 is a top view of the rotary motion device of Fig.34;

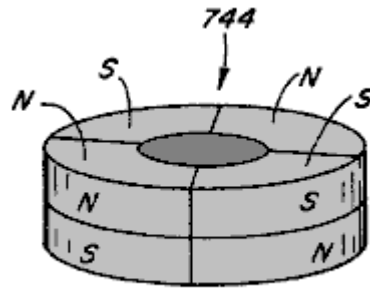

Fig. 36

Fig.36 is a perspective view of the permanent magnet rotor member of the rotary motion device of Fig.34;

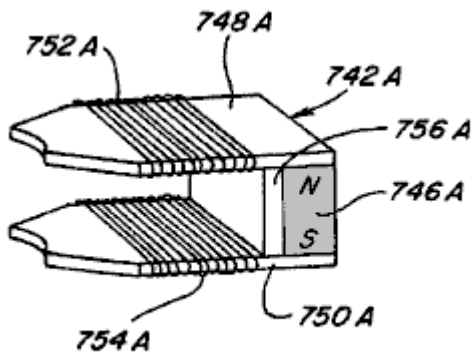

Fig. 37

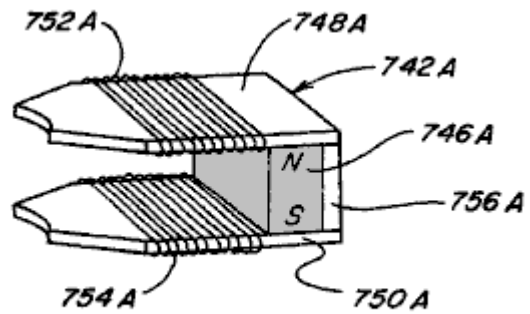

Fig. 38

Fig.37 and Fig.38 show alternative configurations for the control component incorporated into the rotary motion device of Fig.34;

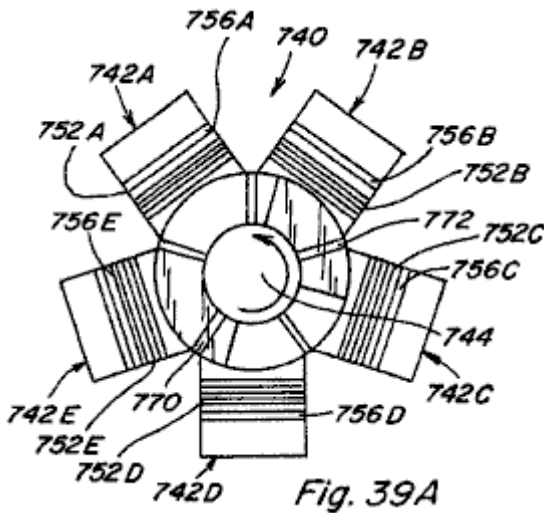

Fig. 39A

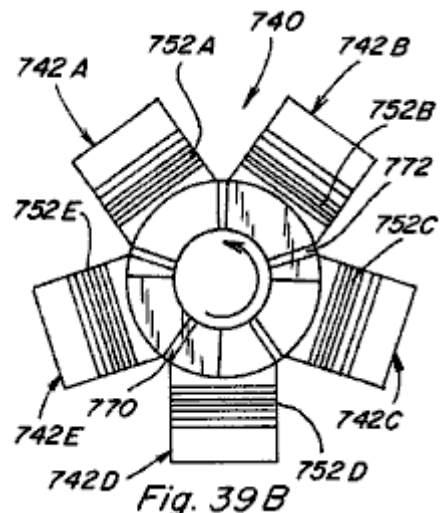

Fig. 39B

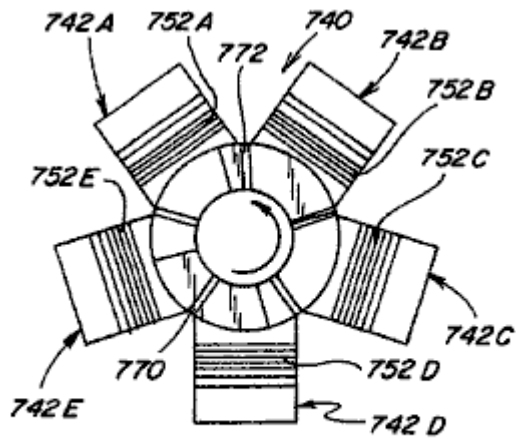

Fig. 39 C

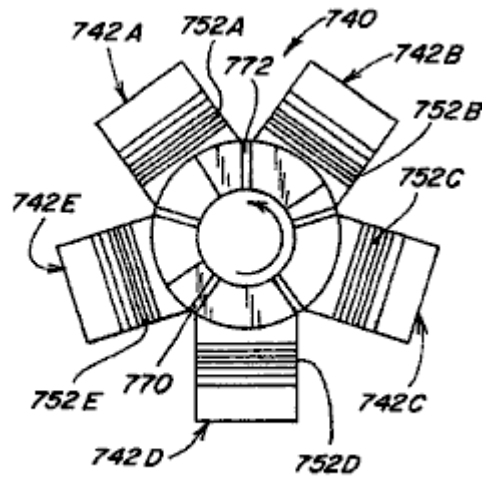

Fig. 39 D

Figs.39A-39D are top views of the rotary motion device of Fig.34 and depict its rotational movement;

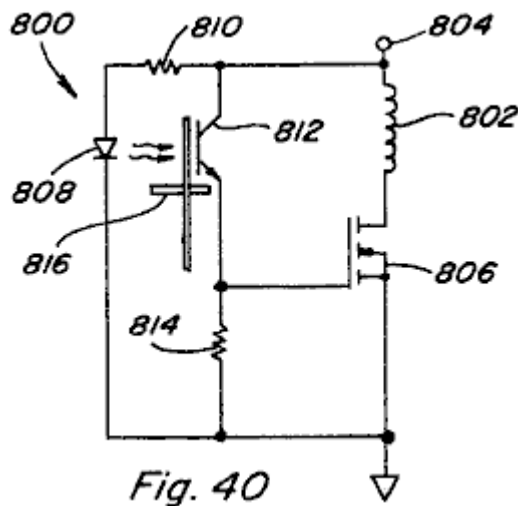

Fig. 40

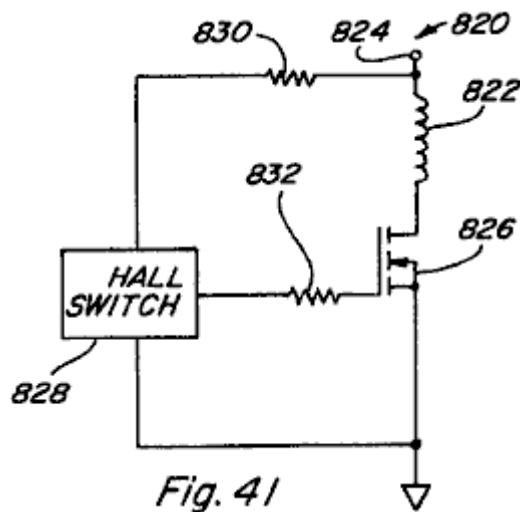

Fig. 41

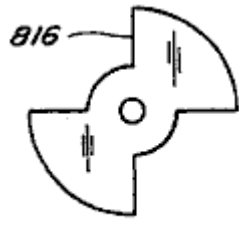

Fig. 42

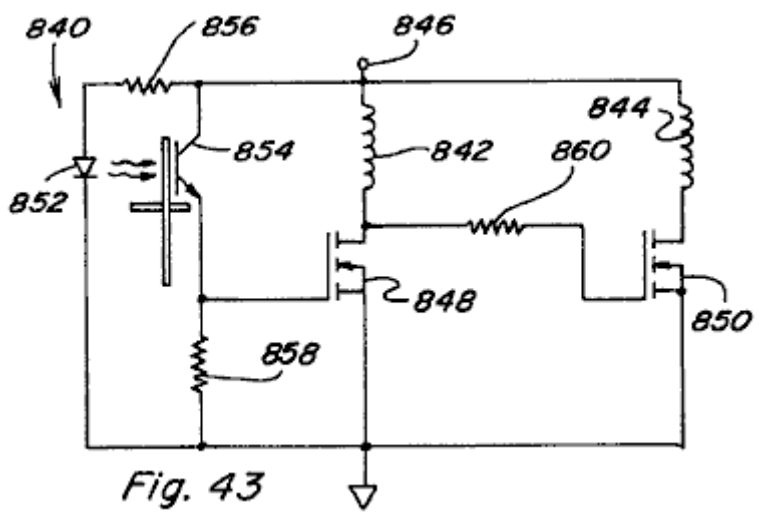

Fig. 43

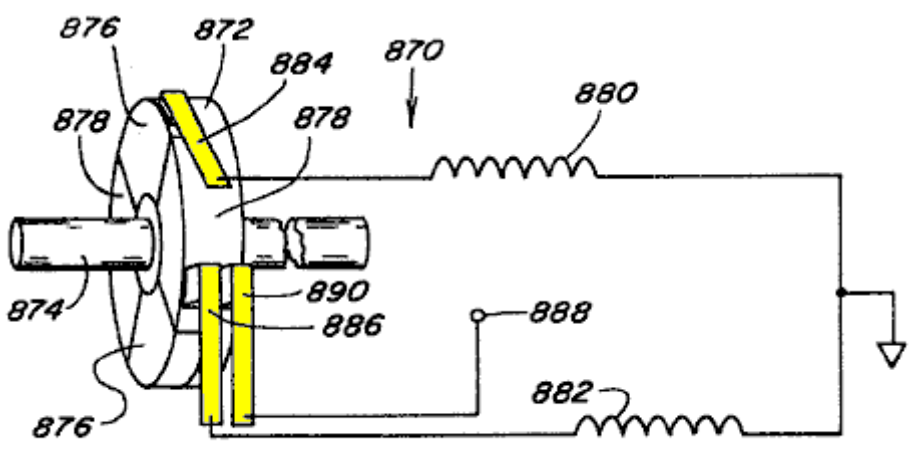

Fig. 44

Figs.40-44 are alternative variations of the circuit for controlling the timed energisation of control coils in the various devices of the present invention;

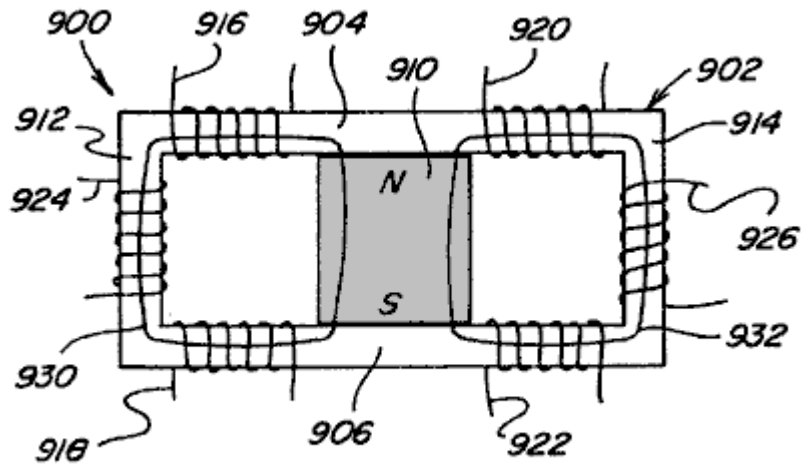

Fig. 45A

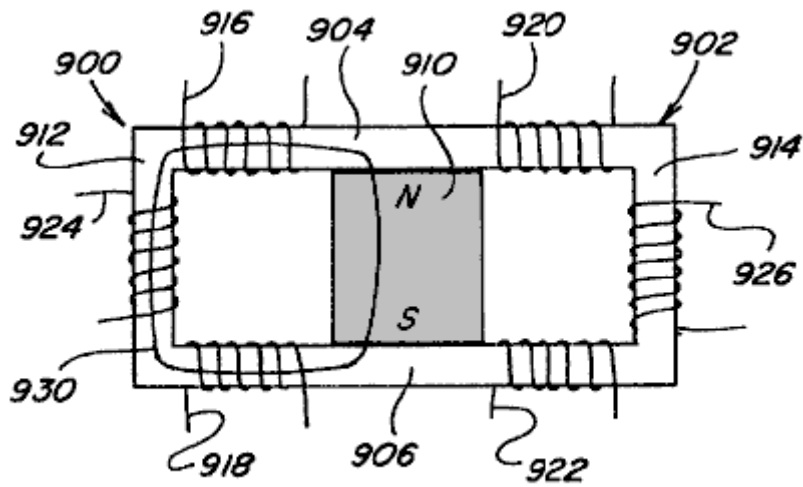

Fig. 45B

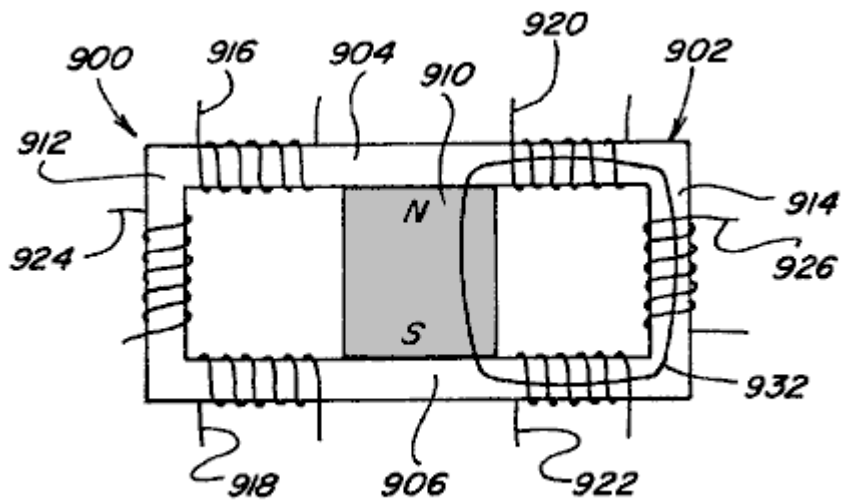

Fig. 45C

Figs.45A-45C and Figs.45X-45Z are side views of two path power conversion devices;

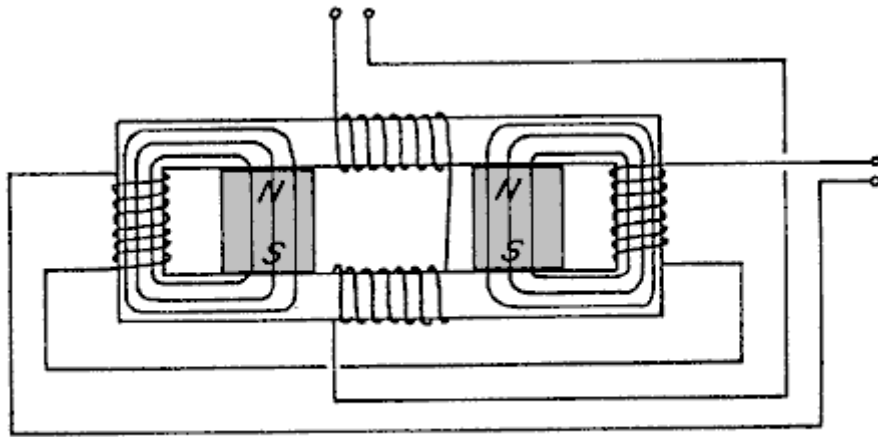

Fig. 45 X

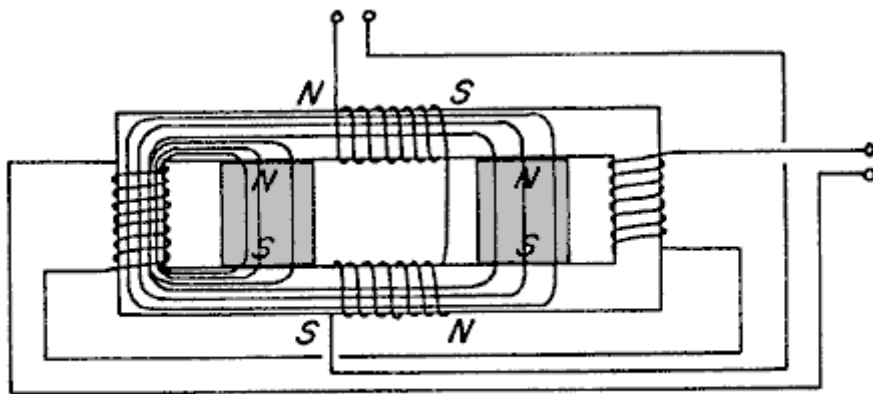

Fig. 45 Y

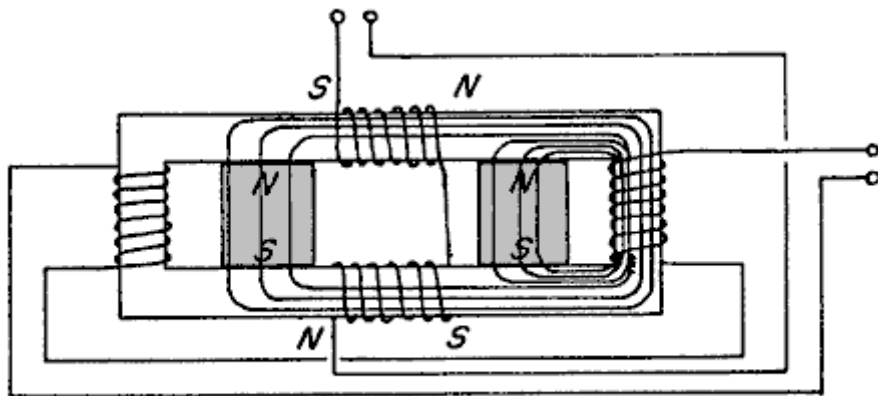

Fig. 45 Z

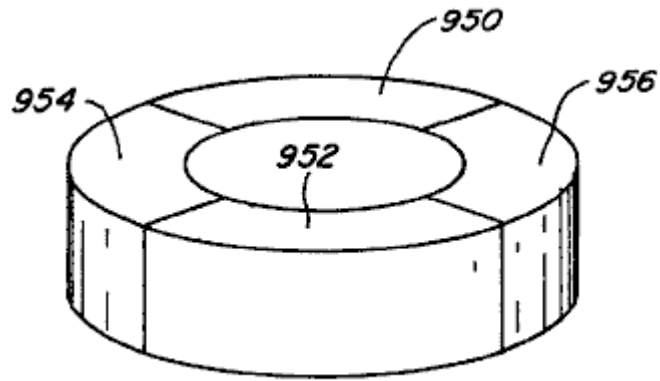

Fig. 46

Fig.46 is a schematic view of the permanent magnet portion of a rotor for use in some embodiments of the present device;

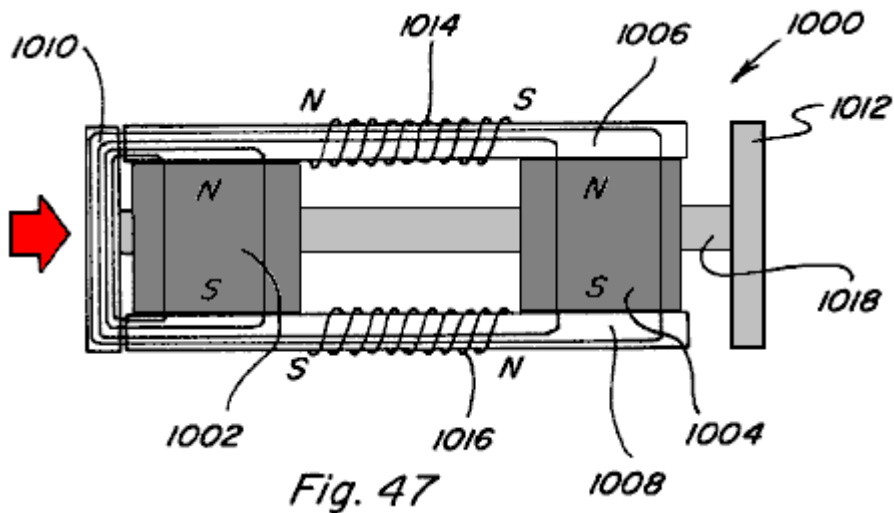

Fig. 47

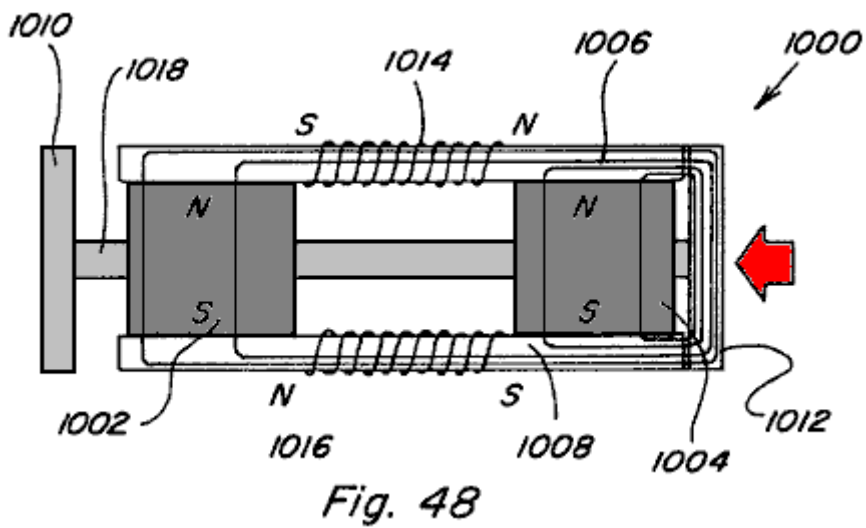

Fig. 48

Fig.47 and Fig.48 show other embodiments of a linear motion device;

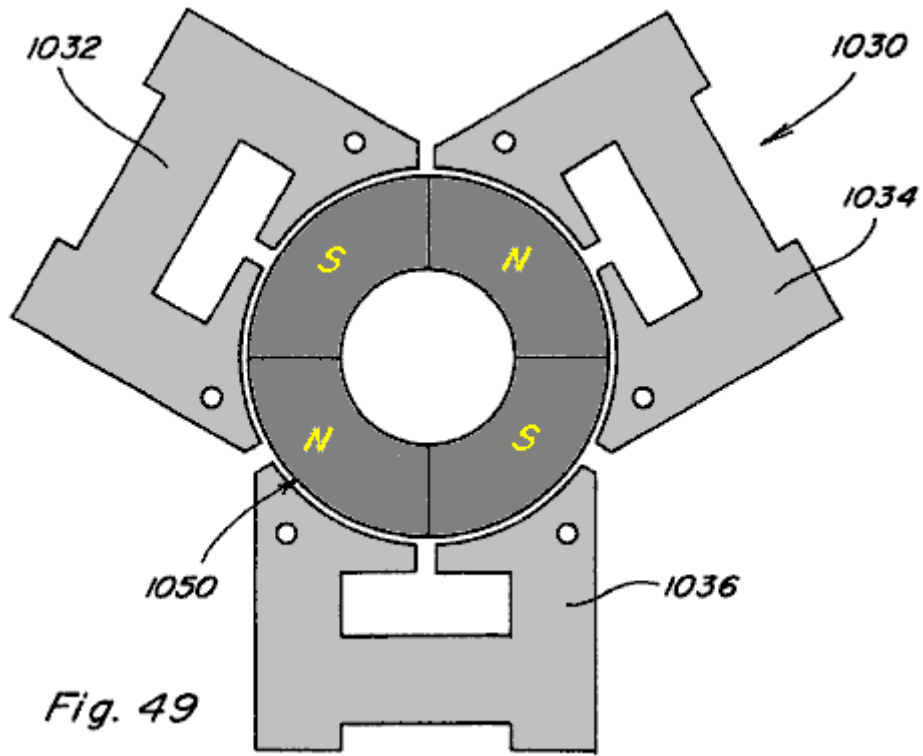

Fig.49 is a top view of another embodiment of a rotating motor like construction; and

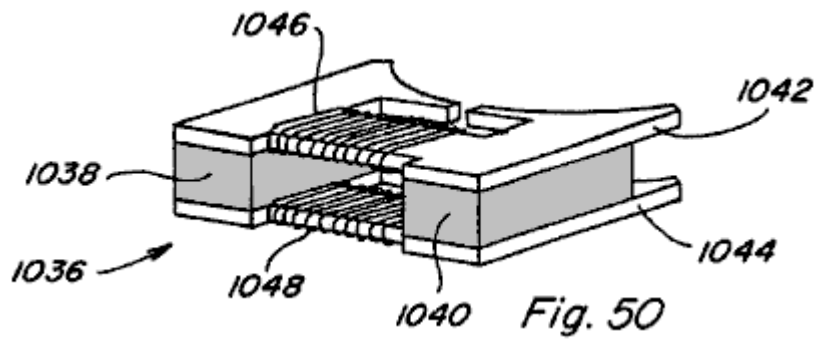

Fig.50 is a schematic view of one of the three stator portions of the device shown in **Fig.49**.

DETAILED DESCRIPTION OF THE DRAWINGS

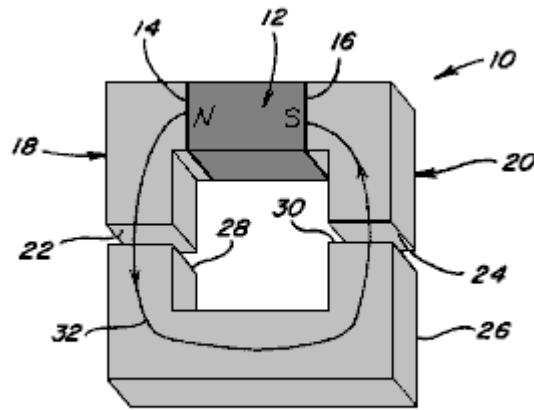

Fig. 1

Referring now to the drawings, Figs.1-4 are provided to facilitate an understanding of various aspects or features of the technology utilised in the present invention. **Fig.1** depicts a device **10** having a magnetic flux producing member **12** which may be a permanent magnet or electromagnet with magnetic poles **14** and **16** as shown. Pole pieces **18** and **20** are positioned adjacent respective poles **14** and **16** to provide a path for the magnetic flux of member **12**. Each pole piece **18** and **20** has a pole piece end face **22** and **24**. As used throughout this specification, it is understood that a pole piece, regardless of its shape or size, is preferably formed of soft iron, steel or some other magnetic material, with the preferred material being one which provides low reluctance, exhibits low hysteresis, and has a high magnetic flux density capability. Accordingly, the various pole pieces disclosed and described herein could likewise be of laminate type construction.

Referring again to **Fig.1** an armature **26**, also formed of magnetic material, is shown with end faces **28** and **30** which are positioned and sized for being placed adjacent pole piece end faces **22** and **24**, such that when so positioned a substantially continuous low reluctance path **32** is provided for magnetic flux from north pole **14**, through pole piece **18**, through armature **26**, through pole piece **16**, and to south pole **16**. The magnetic flux travelling along such path **32** results in a force which tends to hold armature **26** in position aligned with pole piece end faces **22** and **24**. The resulting magnetic coupling or holding force **F** provided between adjacent pole piece end face **22** and armature end face **28**, and between adjacent pole piece end face **24** and armature end face **30**, can be approximated by the following equation:

$$F = B^2 A / 2\mu_0$$

where **B** is the magnetic flux density passing through the adjacent end faces and **A** is the surface area of the adjacent end faces. Assuming that if **B** is uniform throughout flux path **32** and that the area **A** of all end faces **22**, **24**, **28**, and **30** is the same, then the total holding force **F_{T26}** of armature **26** against pole pieces **18** and **20** will be:

$$F_{T26} = B^2 A / \mu_0$$

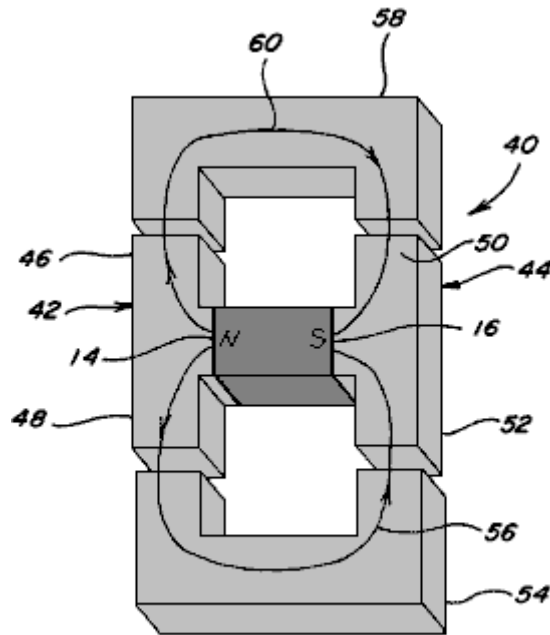

Fig. 2

In Fig.2 a device 40 having the same magnetic flux producing member 12 with magnetic poles 14 and 16 is shown. Pole pieces 42 and 44 are positioned adjacent respective pole faces 14 and 16 to provide two paths, as opposed to one above, for the magnetic flux of member 12. In particular, pole piece 42 includes a first path portion 46 extending beyond a perimeter of north pole face 14 in one direction and a second path portion 48 extending beyond the perimeter of north pole face 14 in another direction. Similarly, pole piece 44 includes a first path portion 50 extending beyond the perimeter of south pole face 16 in one direction and a second path portion 52 extending beyond the perimeter of south pole face 16 in another direction. Each pole piece path portion 46, 48, 50, 52 includes a respective end face. A first armature 54 which can be positioned adjacent to the end faces of pole piece path components 48 and 52 provides a first magnetic flux path 56 and a second armature 58 is which can be positioned adjacent the end faces of pole piece path components 46 and 50 provides a second magnetic flux path 60. If the flux carrying area along flux paths 56 and 60 is the same as the flux carrying area along flux path 32 of Fig.1, the magnetic flux density along each flux path 56 and 60 will be one-half the magnetic flux density along flux path 32 of Fig.1 because the same amount of flux is split between two like paths. The effect of dividing a given amount of magnetic flux along two like flux paths instead of it passing along just one flux path can be seen by examining the holding force on armature 54 as compared to the holding force on armature 26 of Fig.1. As already noted the magnetic flux density along path 56 will be one-half that along flux path 32 and thus the total holding force F_{T54} can be determined as:

$$F_{T54} = (B/2)2A/\mu_0 = B^2A/4\mu_0 = F_{T26}/4.$$

It is therefore seen that dividing the same amount of magnetic flux along two flux paths rather than along one flux path reduces the magnetic holding or coupling force on an armature to one-fourth rather than one-half as might have been expected. This unexpected magnetic holding or coupling force differential, resulting from multiple flux paths, can provide advantageous properties in linear, reciprocating, and rotary motion devices.

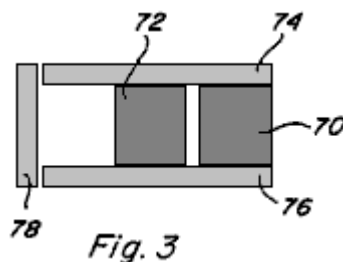

Fig. 3

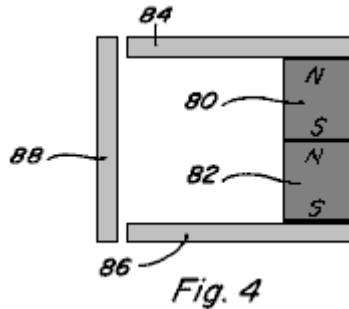

Fig. 4

Referring now to **Fig.3** and **Fig.4**, the behaviour of multiple magnetic flux sources arranged in parallel and series is described as compared to a single flux source. When identical flux sources or magnetic flux producing members **70** and **72** are positioned in parallel as shown in **Fig.3** with pole pieces **74** and **76** positioned adjacent the poles thereof to provide a flux path through armature **78**, the flux density B through armature **78** is double what the flux density would be if only one magnetic flux producing member were present. However, the field intensity H resulting from the two members **70** and **72** remains unchanged. This result holds true regardless of whether members **70** and **72** are both permanent magnets, are both electromagnets, or are a combination of one permanent magnet and one electromagnet. On the other hand, the properties resulting from magnetic flux producing members **80** and **82** arranged pole-to-pole in series between pole pieces **84** and **86**, with armature **88**, as shown in **Fig.4**, will vary depending on the nature of the members **80** and **82**.

In a first case, if both members **80** and **82** are permanent magnets, the magnetic field intensity H resulting from the two permanent magnets will be double that of one permanent magnet and the flux density B through armature **88** will be the same as what the flux density would be if only one permanent magnet type member were present.

In a second case, if both members **80** and **82** are electromagnets, the field intensity H again doubles and the flux density B increases according to the B/H curve or relationship of the pole piece **84**, **86** and armature **88** materials.

In a third case, if member **80** is a permanent magnet and member **82** is an electromagnet, the field intensity H again doubles, but, since the permanent magnet is near flux density saturation B_r the flux density can only be increased from B_r to B_{max} of the permanent magnet. At the point where electromagnet-type member **82** contacts permanent magnet-type member **80** the flux from the electromagnet-type member **82** couples with the flux of the permanent magnet-type member **82** until the flux density through permanent magnet-type member **80** reaches B_{max} . At that point additional flux from electromagnet-type member **82** does not contribute to the flux density along the flux path unless a bypass path around the permanent magnet-type member is provided. Use of such bypass paths will be described below.

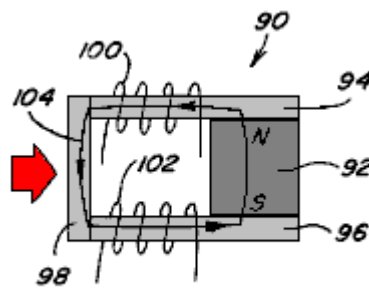

Fig. 5

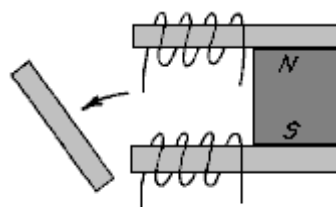
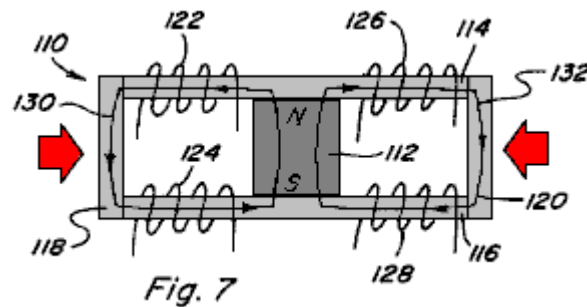

Fig. 6

Controlling the flow of flux along both one and multiple flux paths is best described with reference to **Figs.5-9**. In **Fig.5** and **Fig.6** a permanent magnet device **90** including a permanent magnet **92** having pole pieces **94** and **96** positioned adjacent to its pole faces, and an armature **98** completing a low reluctance path **104** from pole to pole is shown. Control coils **100**, **102** are positioned along path **104**. When control coils **100**, **102** are not energised, the magnetic flux of permanent magnet **92** follows path **104** as shown and armature **98** is held in place against

pole pieces **94, 96** due to the resulting magnetic coupling forces. However, if coils **100, 102** are energised to provide an equal but opposing magnetic flux to that of permanent magnet **92**, the result is that the magnetic flux of permanent magnet **92** is blocked and no magnetic flux traverses the path which includes armature **98** and therefore no magnetic coupling forces act on armature **98** allowing it to fall away as shown in **Fig.6**. The permanent magnet device **90** is useful, although as will become apparent below, it is more advantageous to provide multiple flux paths rather than one.



In this regard, in **Fig.7** a permanent magnet device **110** includes a permanent magnet **112** having pole pieces **114, 116** positioned adjacent the pole faces of it, with armatures **118, 120** completing two low-reluctance paths **130, 132** from pole to pole thereof. Control coils **122, 124** are positioned along path **130** and control coils **126, 128** are positioned along path **132**. The two paths provided are assumed to be of equal reluctance. With no coils energised, the magnetic flux of permanent magnet **112** divides equally along flux path **130** and flux path **132** such that both armatures **118, 120** are subjected to a magnetic coupling force which holds them in place against pole pieces **114, 116**.

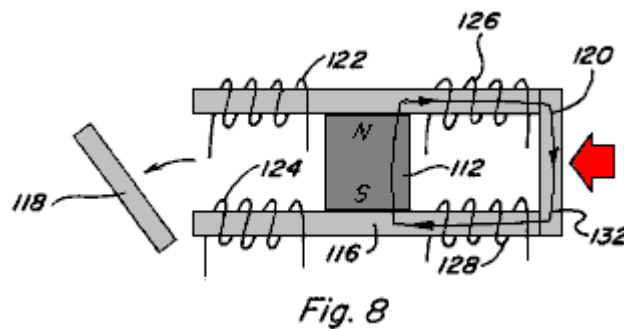

If coils **122, 124** are energised to provide a magnetic flux equal to but opposing the magnetic flux which travels along flux path **130** from permanent magnet **112** when no coils are energised, the result is that the magnetic flux of permanent magnet **112** is blocked and no magnetic flux traverses the path which includes armature **118** and therefore no magnetic coupling forces act on armature **118** allowing it to fall away as shown in **Fig.8**. Further, the magnetic flux traversing path **132** will be double that of when no coils are energised and therefore the magnetic coupling force on armature **120** will be about four (4) times that of when no coils are energised. By energising coils **126, 128** in an opposing manner a similar result would be achieved such that armature **120** would fall away and such that the magnetic coupling force on armature **118** would be increased.

If coils **122, 124** are energised to provide a magnetic flux equal to and aiding the magnetic flux which travels along flux path **130** when no coils are energised, the result is that the control coils couple completely with the magnetic flux of permanent magnet **112** and no magnetic flux traverses the path which includes armature **120** and therefore no magnetic coupling forces act on armature **120** allowing it to fall away as shown in **Fig.9**. Further, the magnetic flux traversing path **130** will be double that of when no coils are energised and therefore the magnetic coupling force on armature **118** will be about four (4) times that when no coils are energised. By energising coils **126, 128** in an aiding manner a similar result would be achieved such that armature **118** would fall away and the magnetic coupling force on armature **120** would be increased.

Based on the foregoing, it is seen that the full magnetic coupling force available from the permanent magnet **112**, can be switched from one path to another path by the application of one half the power it would require for a coil alone to produce the same magnetic flux along one path. The ability to switch the full magnetic coupling force easily from one path to another, allows for efficient reciprocating, linear, and rotary motion and power conversion to be achieved.

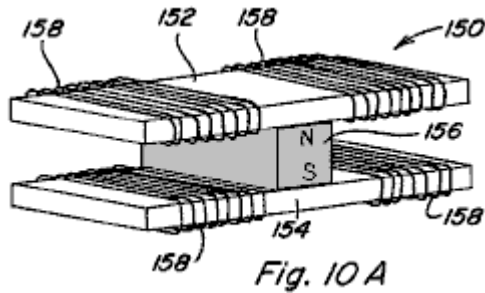

The basic device utilised to achieve permanent magnet flux division and to control such permanent magnet flux division is defined herein as a "permanent magnet control component," various configurations of which are shown by way of example only, and not by way of limitation, in **Figs.10A-10F**. **Fig.10A** depicts a permanent magnet control component **150** in which pole pieces **152** and **154** are positioned adjacent to the pole faces of permanent magnet **156** to provide two magnetic flux paths extending from opposite sides of permanent magnet. Control coils **158** are positioned along each path.

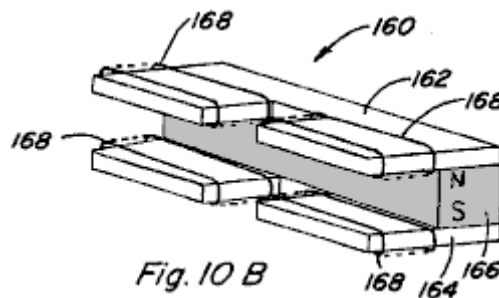

Fig.10B depicts a permanent magnet control component **160** in which pole pieces **162** and **164** are positioned against the pole faces of permanent magnet **166** to provide two spaced, adjacent magnetic flux paths extending from the same side of permanent magnet **166**. Control coils **168** are positioned along each path.

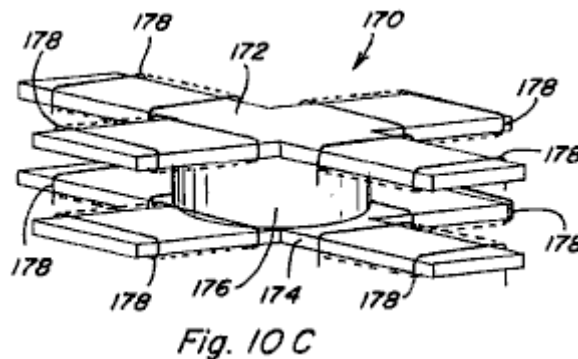

Fig.10C depicts a permanent magnet control component **170** in which pole pieces **172** and **174** are configured so as to be positioned adjacent the pole faces of permanent magnet **176** so as to provide four flux paths, each flux path extending in a respective direction from permanent magnet **176**. Control coils **178** are also positioned along each path.

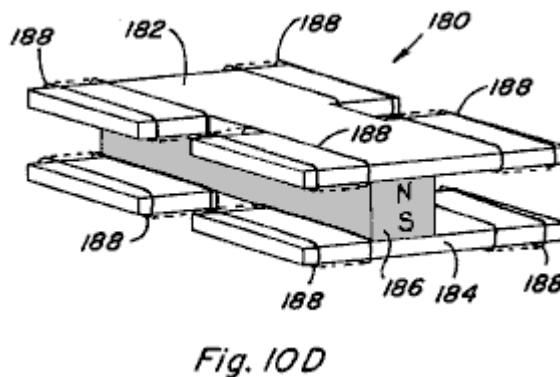

Fig.10D depicts another four-path configuration of a permanent magnet control component **180** in which pole pieces **182, 184** are configured and positioned to provide four flux paths for permanent magnet **186**, with a pair of spaced, adjacent flux paths extending from each side of permanent magnet **186**. Control coils **188** are positioned along each path.

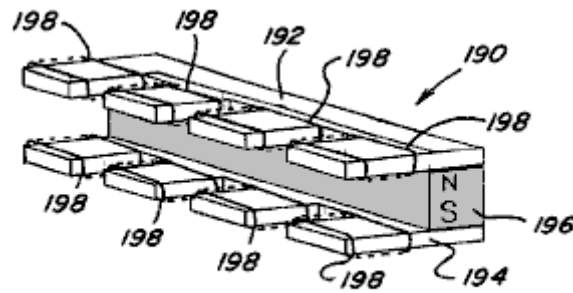

Fig. 10 E

Fig.10E depicts another four-path configuration of a permanent magnet control component **190** in which all four flux paths formed by pole pieces **192, 194** extend from one side of permanent magnet **196**. Again, control coils **198** are positioned along each flux path.

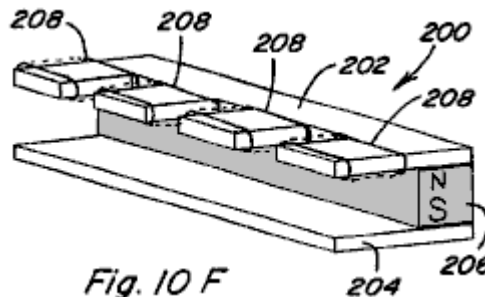

Fig. 10 F

Fig.10F still further depicts a four-path configuration of a permanent magnet control component **200** in which pole pieces **202, 204** extend to one side of permanent magnet **206**, with pole piece **202** defining four flux paths and with pole piece **204** including a continuous return path. Control coils **208** are positioned along each path of pole piece **202**. Many other variations are possible.

Accordingly, it is seen that a variety of different configurations of permanent magnet control components are possible, in accordance with the present invention. The important considerations for division of permanent magnet flux in such permanent magnet control components include, extending each pole piece to, or beyond, the outer perimeter of the pole face of the permanent magnet in each region where a flux path is intended and assuring that the pole face of the permanent magnet intersects each of the flux paths. It is not necessary for each pole piece to include the same number of path portions extending beyond the perimeter of the respective permanent magnet pole face as noted with reference to permanent magnet control component **200**. Although two control coils are shown along each of the flux paths in **Figs.10A-10E**, it is apparent from component **200** in **Fig.10F** that one control coil positioned along a flux path is generally sufficient for purposes of the present invention. Further, although in the illustrated configurations each pole piece is positioned to contact a respective pole face of the permanent magnet, a small spacing between a pole piece and its adjacent permanent magnet pole face could be provided, particularly in applications where relative movement between the subject pole piece and the permanent magnet will occur.

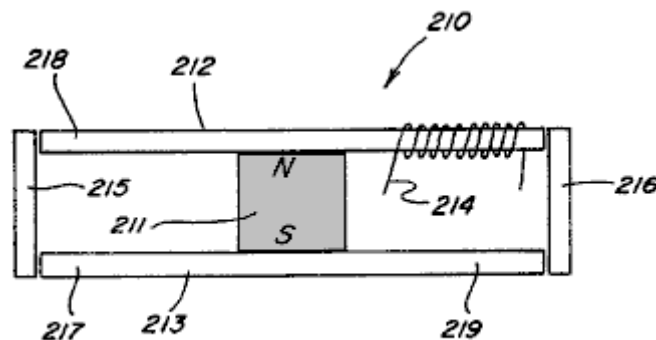

Fig. 10 G

In its simplest form a two path permanent magnet control component only requires one control coil positioned along one of the control paths to permit the magnetic flux of a permanent magnet to be switched between the two paths. In particular, a side view of such a two path component **210** is shown in **Fig.10G** and includes a permanent magnet **211** pole pieces **212** and **213**, and control coil **214** which may be connected to a suitable control circuit. By alternating energising control coil **214** in an opposing manner and an aiding manner the magnetic flux of permanent magnet can be switched between the path including armature **215** and the path including armature **216**. When control coil **214** is energised in an opposing manner the magnetic flux will traverse the path including armature **215** and when control coil **214** is energised in an aiding manner the magnetic flux will traverse the path including armature **216**. Control coil **214** could also be placed at any of the positions **217**, **218**, or **219** to achieve the flux path switching.

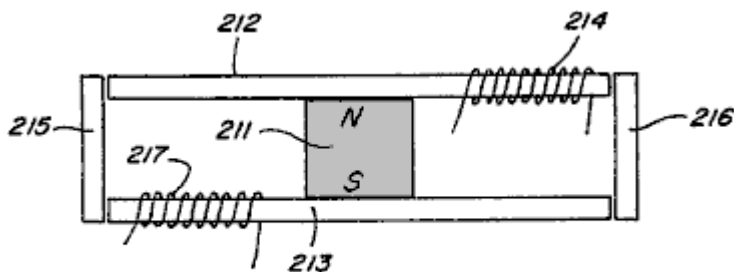

Fig. 10 H

Further, in the two coils embodiment shown in **Fig.10H** control coil **217** is added. In such a device, flux switching can be achieved by simultaneously energising control coil **214** in a flux aiding manner and control coil **217** in a flux opposing manner, and by then simultaneously reversing the energisation of the respective control coils **214** and **217**.

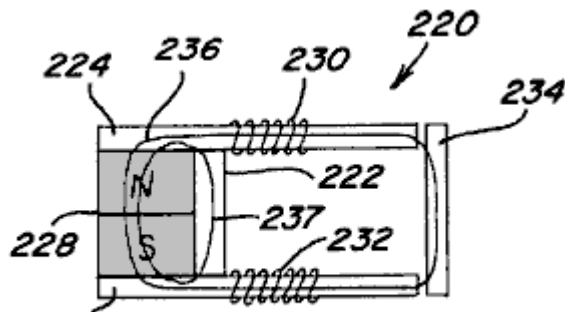

Fig. 11 A

Reference is made to **Figs.11A-11F** which depict devices similar to that of **Figs.5-6** except that a bypass, formed of magnetic material, is provided in each case. In device **220** of **Figs.11A-11C** a bypass **222** is provided from pole piece **224** to pole piece **226** and is located between permanent magnet **228** and control coils **230**, **232**, with armature **234** located adjacent the ends of pole pieces **224**, **226**. In **Fig.11A** with no coil energisation, magnet flux components **236** and **237** travel as shown.

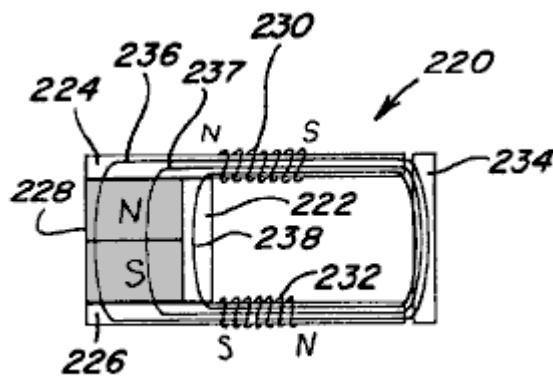
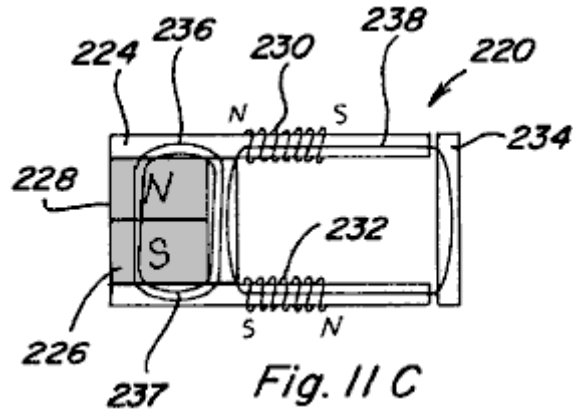

Fig. 11 B

When coils **230** and **232** are energised in an aiding or adding manner as in **Fig.11B**, the result is permanent magnet magnetic flux components **236** and **237** travelling as shown, and with the added magnetic flux component

238 from coils 230 and 232 also travelling as shown. Thus, in device 220 energising the coils in an aiding manner results in an increased magnetic coupling force on armature 234.



In Fig.11C coils 230, 232 are energised in an opposing exceeding manner which results in permanent magnetic flux components 236 and 237 travelling as shown and excess magnetic flux component 238 travelling as shown. Thus, in device 220 energising the coils in an opposing exceeding manner results in magnetic coupling force on armature 234, albeit smaller than that in the aiding exceeding case.

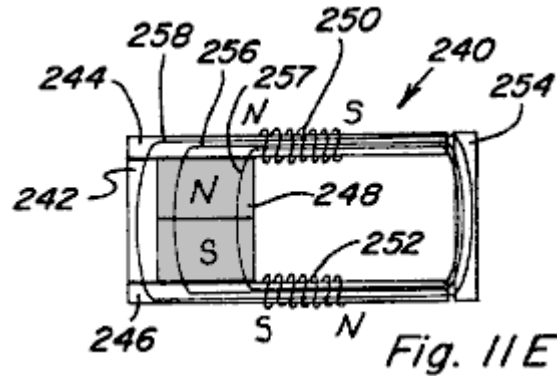
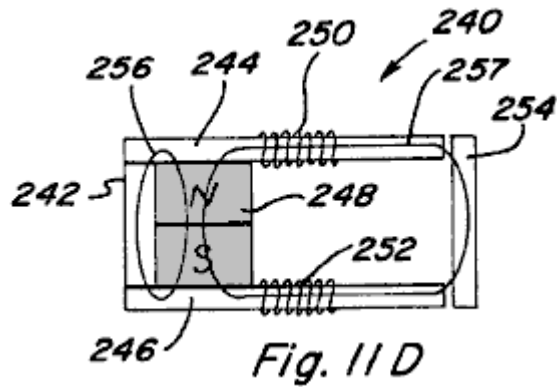

In device 240 of Figs.11D-11F a bypass 242 is provided between pole piece 244 and pole piece 246 but is located on an opposite side of permanent magnet 248 as compared to control coils 250, 252 and armature 254. Permanent magnet flux components 256 and 257 are shown for no coil energisation in Fig.11D. In Fig.11E the paths of permanent magnet flux components 256 and 257, as well as excess coil magnetic flux 258, are shown when coils 250, 252 are energised in an aiding exceeding manner.

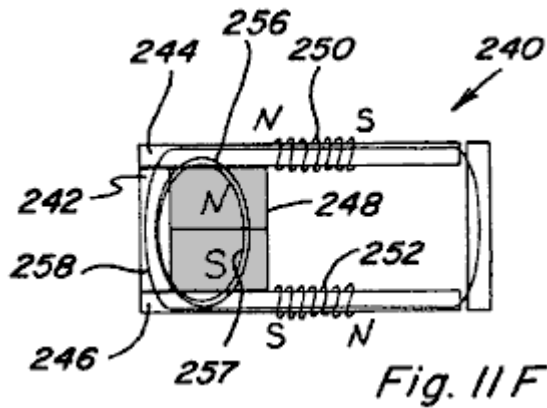

Fig. 11 F

In Fig.11F the path of each magnetic flux component 256, 257, and 258 is shown when coils 230, 232 are energised in an opposed exceeding manner.

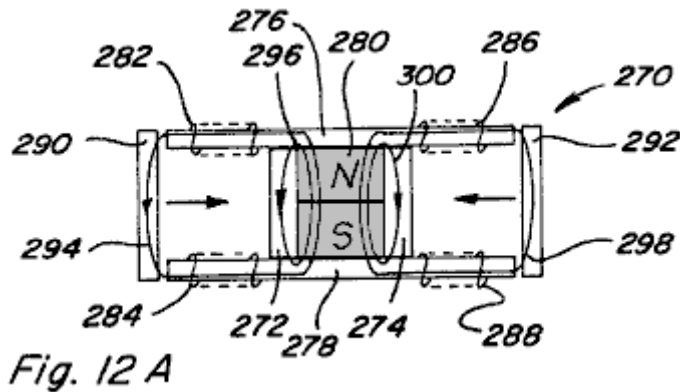

Fig. 12 A

Figs.12A-12E depict a device 270 similar to that shown in Figs.7-9 except that bypasses 272 and 274 are provided from pole piece 276 to pole piece 278. Bypass 272 is located between permanent magnet 280 and control coils 282, 284 and bypass 274 is located between permanent magnet 280 and control coils 286, 288. Armatures 290 and 292 are also provided. When no coils are energised permanent magnet magnetic flux components 294, 296, 298, and 300 travel as shown in Fig.12A.

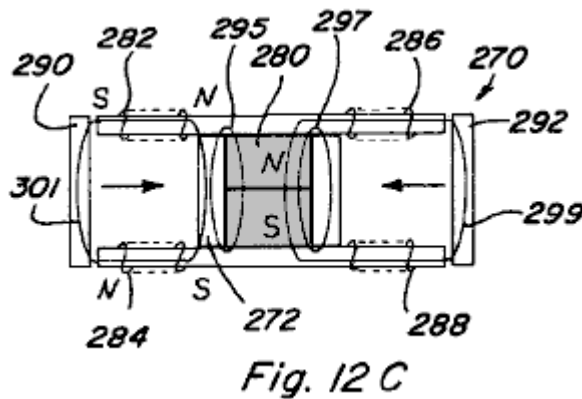

Fig. 12 C

If coils 282, 284 are energised in an opposing manner permanent magnet flux components 295, 297, and 299 travel as shown, with no flux component traversing the path which includes armature 290 and therefore no magnetic coupling force acting thereon. This would be the case when coils 282, 284 are energised to the level where the coils magnetic flux just blocks, but does not exceed, the magnetic flux component 294 (Fig.12A) from permanent magnet 280. However, if coils 282, 284 are energised in an opposed exceeding manner an excess coil magnetic flux component 301 is produced which travels a path including armature 290 and bypass 272 results as shown in Fig.12C.

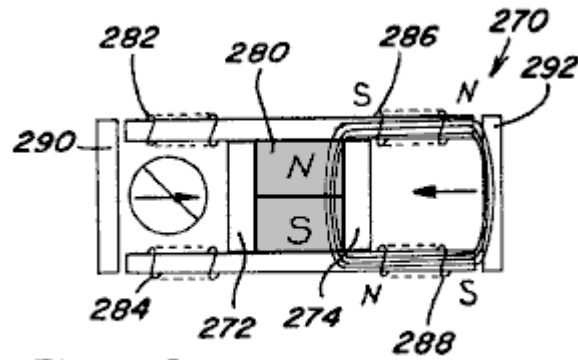

Fig. 12 D

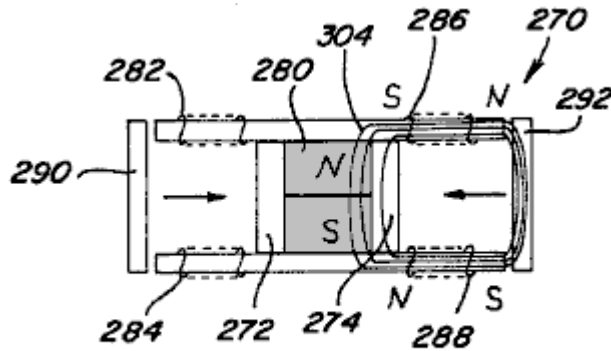

Fig. 12 E

Coils 286, 288 may be energised in an aiding manner such that all permanent magnet magnetic flux travels along the path which includes armature 292 as shown in Fig.12D. If coils 286, 288 are energised in excess of the level of Fig.12D then the excess magnetic flux component 304 traverses the path which includes armature 292 and bypass 274 as shown in Fig.12E, thereby increasing the magnetic coupling force on armature 292 as compared to Fig.12D. The advantage of incorporating such bypasses into permanent magnet control components in certain applications will become apparent below.

Reciprocating Motion

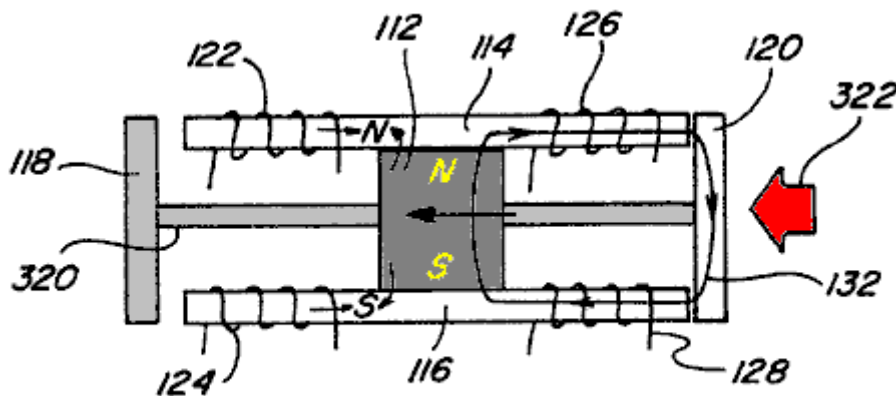
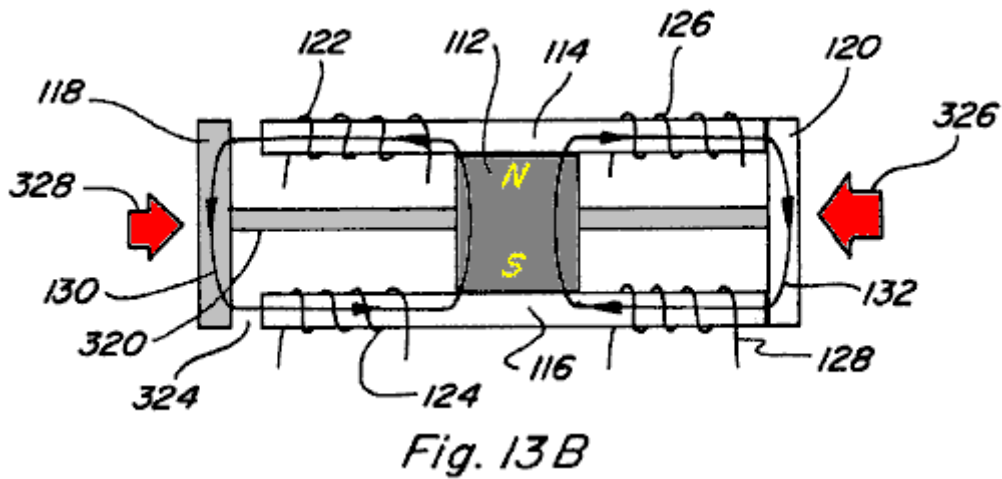

Fig. 13 A

As mentioned above, controlling the path of magnetic flux from a permanent magnet can be useful in a variety of applications such as achieving reciprocating motion. In this regard, if the device 110 of Figs.7-9 is modified such that armatures 118 and 120 are fixed to a sliding shaft 320 as shown in Figs.13A-13C, and if the distance between the armatures is greater than the end to end length of pole pieces 114, 116, limited linear motion in two directions (left and right in Figs.13A-13C), and therefore linear reciprocating motion, can be achieved by the timed, alternate delivery of electrical signals to control coils 122, 124 and control coils 126, 128. By way of example, Fig.13A represents the position of shaft connected armatures 118, 120 when coils 122, 124 are energised in an opposing manner to block the flux of permanent magnet 112 such that all magnetic flux traverses path 132 as shown and such that the resulting magnetic coupling force acts to the left as indicated by arrow 322.



As shown in **Fig.13B** when coils **122, 124** are de-energised the magnetic flux from permanent magnet **112** can again travel along path **130** through armature **118**. However, due to the air gap **324** between armature **118** and pole pieces **114, 116** the reluctance along path **130** will be significantly greater than the reluctance along path **132**. Accordingly, the amount of magnetic flux which flows along path **130** will be less than the amount of magnetic flux which flows along path **132** such that the magnetic coupling force on armature **118** acting to the right will be significantly less than the magnetic coupling force on armature **120** acting to the left as shown by arrows **326** and **328**, which arrows are sized to represent the strength of the respective directional force.

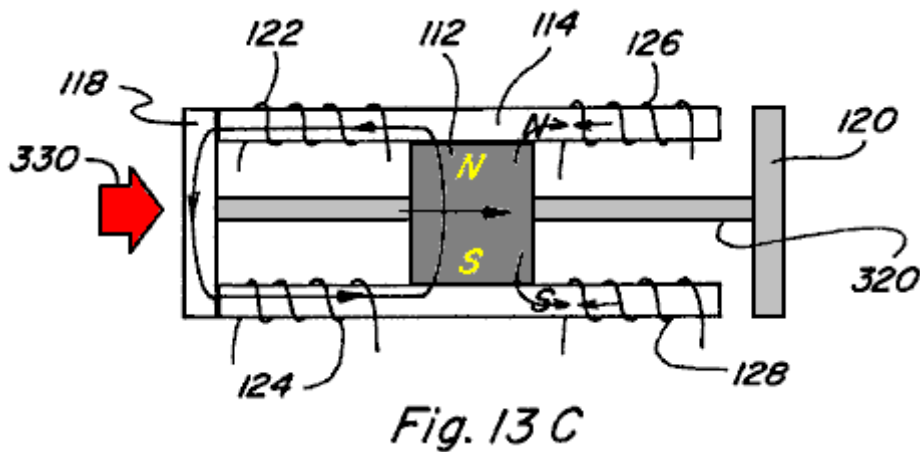

Fig.13C represents the position of shaft connected armatures **118, 120** after coils **126, 128** are energised in a manner to oppose the flux of permanent magnet **112** such that all flux traverses path **130** and the resulting magnetic coupling force on armature **118**, depicted by arrow **330**, moves the shaft **10** connected armatures **118, 120** to the right.

Control coils **122, 124** and **126, 128** could also be energised in a flux aiding manner to achieve the same result. In such a device, **Fig.13A** would represent coils **126, 128** energised to aid magnetic flux along path **132**, **Fig.13B** would again represent no coils energised, and **Fig.13C** would represent coils **122, 124** energised to aid magnetic flux along path **130**.

Thus, by alternately energising and de-energising control coils **122, 124** and **126, 128** a linear reciprocating motion of shaft connected armatures **118, 120** may be achieved. Further, such reciprocating motion may be achieved by energising the coils in either an opposing or aiding manner. The magnetic coupling force exerted on a given armature when **20** the control coils are energised to establish all magnetic flux along a single path which includes that armature is significantly greater than the magnetic coupling force which would be exerted on such armature by an identical energisation of the control coils in the absence of the permanent magnet.

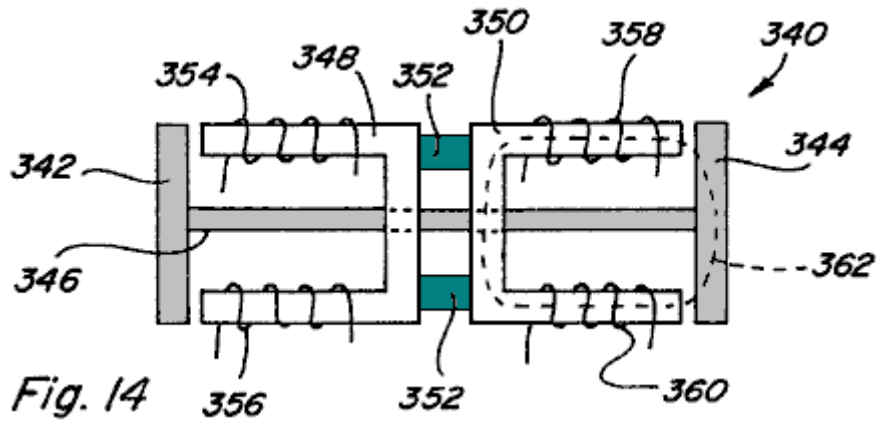

Fig. 14

This is demonstrated with reference to **Fig.14** which depicts a reciprocating device **340** in which only coils or electromagnets are utilised. As shown armatures **342** and **344** are connected by shaft **346**, and each armature **342**, **344** includes a respective U-shaped pole path piece **348**, **350** which pole path pieces are mechanically connected by a non-magnetic material **352**. Each pole path piece **348** and **350** has respective control coils **354**, **356** and **358**, **360** positioned along them. By comparison with the device of **Figs.13A-13C**, if coils **358**, **360** of device **340** are energised to cause magnetic flux flow in either direction, clockwise or counterclockwise, along path **362**, the amount of electrical energy which would be required in order to achieve the same magnetic coupling force on armature **344** as achieved on armature **120** above in **Fig.13A** would be twice that delivered to coils **122**, **124** or **126**, **128** in **Fig.13A**. It is therefore demonstrated, that by controlling or switching the flow of magnetic flux from a permanent magnet between at least two different paths results in greater coupling forces per unit of input electrical energy, and therefore that such control or switching will enable more work to be achieved per unit of input electrical energy.

As described above, if a coil is energised beyond the point where the magnetic flux produced by the coil aiding the amount of the permanent magnet's flux that is either opposed or aided, the extra magnetic flux needs a low reluctance path between the poles of the coil that produces the excess magnetic flux. If a complete low-reluctance path is not provided for the excess magnetic flux, there is little potential for taking advantage of the excess magnetic flux in terms of producing additional magnetic coupling forces. The path for such excess flux cannot be through a permanent magnet member. In assemblies which include an armature on each path, the armature will provide the necessary low-reluctance path.

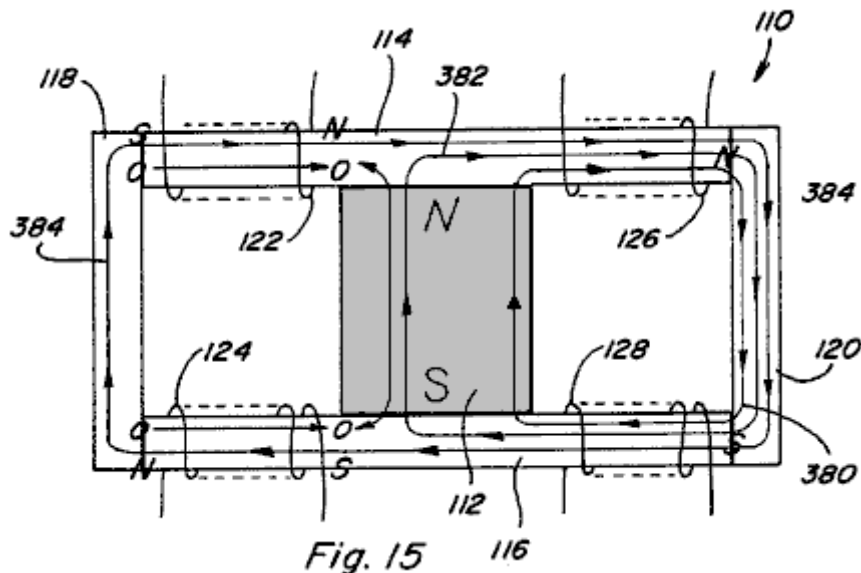
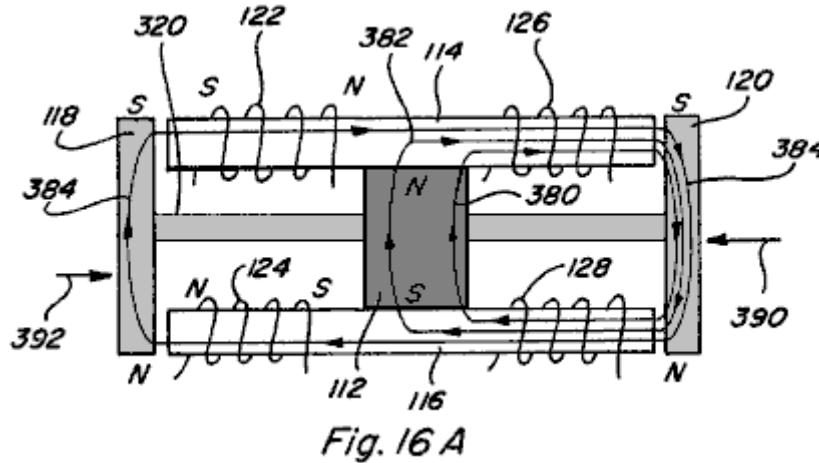

Fig. 15

Referring to **Fig.15**, various components of the magnetic flux in device **110** (**Figs.7-9**) are depicted by numerals **380**, **382**, and **384** for the case when coils **122**, **124** are energised to oppose the magnetic flux of permanent magnet **112** in an amount which exceeds the level of magnetic flux which permanent magnet **112** would cause to flow through armature **118** when no coils are energised. **Fig.15** is likewise representative of the case when coils **126**, **128** are energised to aid the magnetic flux of permanent magnet **112** by an amount which exceeds the level of magnetic flux which permanent magnet **112** would cause to flow through armature **118** when no coils are energised. In particular, magnetic flux component **380** represents the magnetic flux of permanent magnet **112** which normally flows through the path including armature **120**; magnetic flux component **382** represents the magnetic flux of permanent magnet **112** which is diverted by the opposing field of coils **122**, **124** so as to traverse

the path which includes armature 120; and magnetic flux component 384 represents the magnetic flux produced by coils 122, 124 which is in excess of the diverted magnetic flux 382. As shown, the excess magnetic flux 384 produced by coils 122, 124 traverses the path which includes armature 120 and bypasses permanent magnet 112 so as to also traverse the path which includes armature 118. Thus, the excess magnetic flux produced by coils 122, 124 adds to the permanent magnet flux traversing the path which includes armature 120, thus increasing the magnetic coupling force on armature 120, while at the same time providing a magnetic coupling force on armature 118.



In a reciprocating device where armatures 118 and 120 are connected by shaft 320 as shown in Figs.13A-13C and again in Fig.16A, excess magnetic flux 384 will increase magnetic coupling force 390 on armature 120 acting to the left. However, because such excess flux 384 also traverses the path which includes armature 118, such excess magnetic flux 384 also results in a magnetic coupling force 392 on armature 118 which acts to the right. Even though excess magnetic flux 384 traversing the path which includes an armature 118 has an opposite polarity to that which would traverse the path due to permanent magnet 112, the magnetic coupling force on armature 118 still acts to the right because armature 118 is not polarity sensitive, that is, armature 118 will be attracted regardless of the direction of the magnetic flux traversing the path. The overall effect is that a resultant force which is the difference between force 390 and force 392 will act on the shaft-connected armatures 118, 120. However, if armatures 118 and 120 were formed by permanent magnets having polarities as shown at the top and bottom of such armatures, the force acting on each armature would be in the same direction and therefore additive.

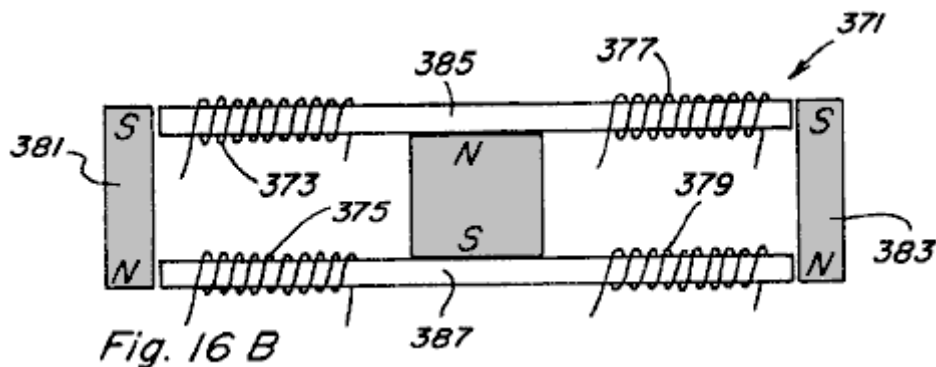

In this regard reference is made to Fig.16B in which a two path device 371 having four control coils 373, 375, 377 and 379 is shown with the illustrated armatures being formed by permanent magnets 381 and 383 having polarities as shown. With no coils energised both permanent magnet armatures 381 and 383 are attracted to the ends of pole pieces 385 and 387. With coils 373, 375 energised in an opposing manner and coils 377, 379 energised in an aiding manner, the attractive force on permanent magnet armature 383 will generally increase and the attractive force on permanent magnet armature 381 will generally decrease.

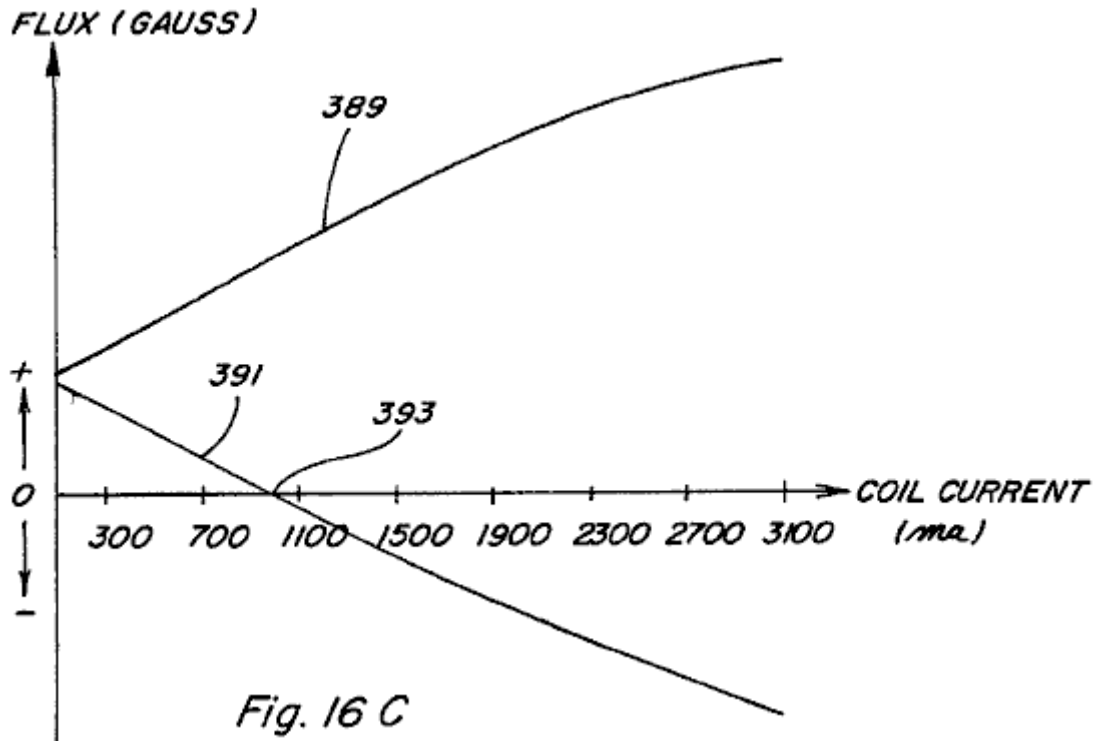

Fig. 16 C

This is demonstrated with reference to the graph of **Fig.16C** which depicts a graph of the current flowing in the control coils on the x-axis versus the magnetic flux in gauss on the y-axis with line **389** representing the flux along the aiding side of device **371** and line **391** representing the flux along the opposing side of device **371**. As shown, the magnetic flux on the coil opposing side decreases as the coil current increases and passes through zero at point **393**. After point **393**, reverse magnetic flux begins to be produced and would result in a repelling force on permanent magnet armature **381**. In some applications, particularly those where permanent magnet armatures and rotors are not utilised, it is critical to recognise point **393** so that reverse magnetic flux is not produced.

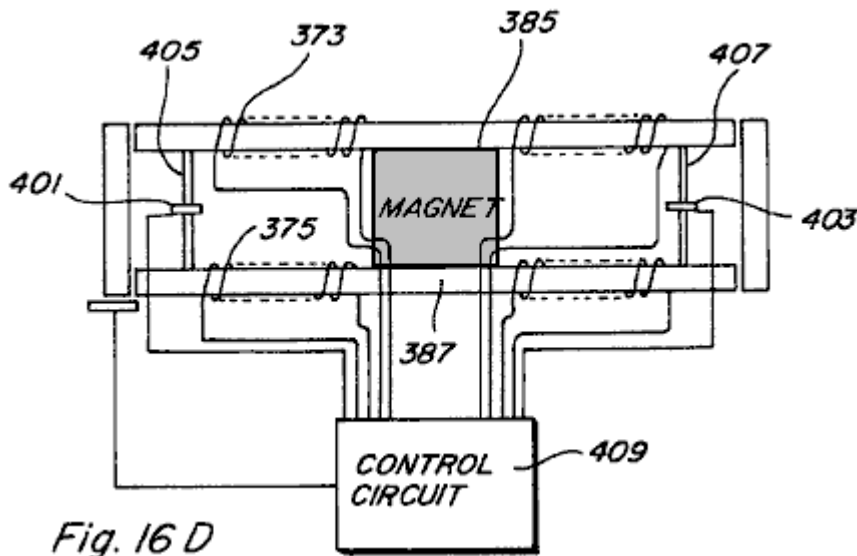
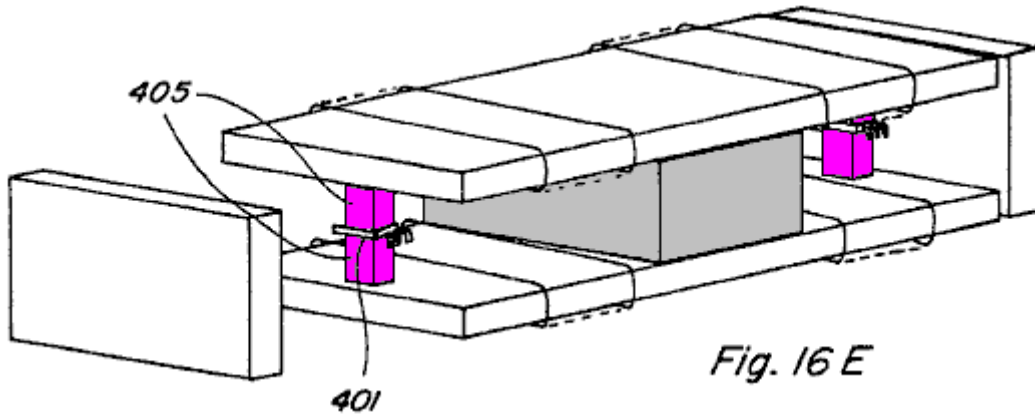
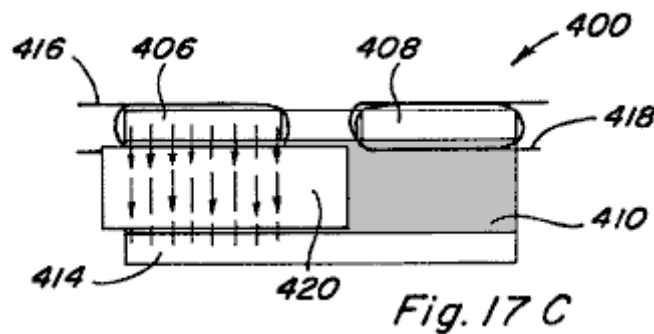
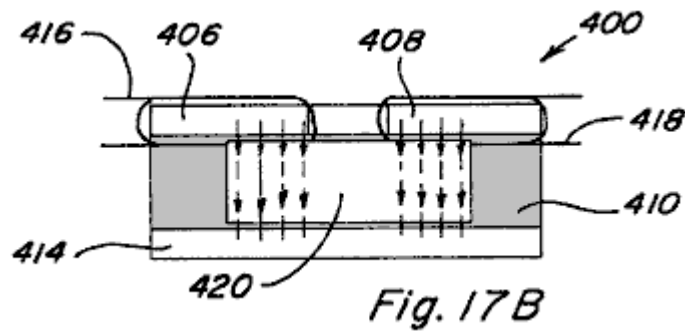
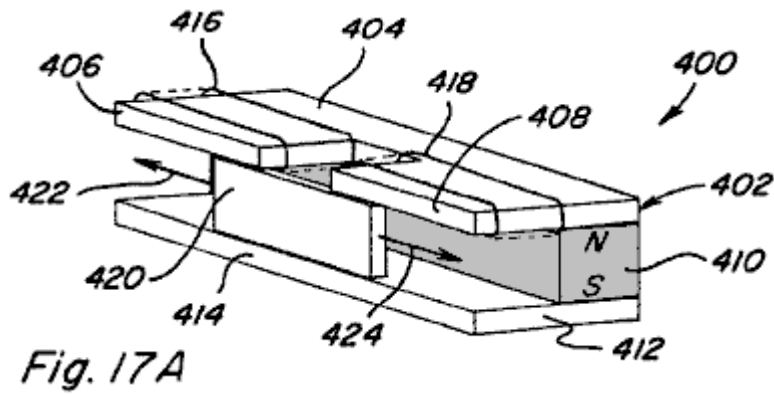
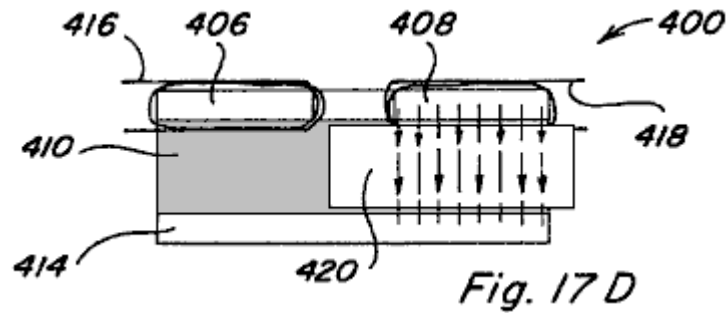

Fig. 16 D



In this regard, reference is made to **Fig.16D** and **Fig.16E**, in which use of Hall Effect switches **401** and **403** is made to enable control of the coil energising current in situations where it is desirable to prevent reverse magnetic flux. As shown, small bypasses **405** and **407** are provided with Hall Effect switches **401** and **403** positioned in gaps along them, the switches being connected to control circuit **409**. As the flux travelling along the bypass path falls to zero, the Hall Effect switch can be utilised to prevent further energisation of the control coils so that no reverse flux is created.





Another embodiment of a device 400 which would provide reciprocating motion is shown in **Figs.17A-17D** in which a permanent magnet control component 402 having two flux paths may be provided. A first pole piece 404, has two spaced, adjacent path portions 406 and 408 extending beyond the perimeter of the pole face of permanent magnet 410, and a second pole piece 412 includes only one continuous portion 414 extending beyond the perimeter of the pole face of permanent magnet 410, each path portion 406 and 408 of pole piece 404 being substantially aligned with at least a part of portion 414 of pole piece 412. Control coil 416 is positioned along pole piece path portion 406 and control coil 418 is positioned along pole piece portion 408. An armature 420 is positioned in the region between pole piece path portions 404, 406 and pole piece portion 414 and is free to slide from side to side as shown by arrows 422 and 424.

A front view of component device 400 with no coils energised and armature 420 at a mid-point depicts flux flowing from the north pole face of permanent magnet 410, through each of pole piece path portions 406 and 408, through armature 420, and returning to the south pole face through pole piece portion 414. Thus, the magnetic flux divides equally along two paths. If coil 416 is energised in an aiding manner, or if coil 418 is energised in an opposing manner, all or a majority of the magnetic flux of the permanent magnets can be made to flow through pole piece portion 406 so that a resulting magnetic coupling force on armature 420 causes it to move to the left as shown in **Fig.17C**.

Likewise, if control coil 416 is energised in an opposing manner, or if control coil 418 is energised in an aiding manner, all or a majority of the permanent magnet flux can be made to flow through pole piece path portion 408 such that a resulting magnetic coupling force on armature 420 causes it to move to the right as shown in **Fig.17D**. Accordingly, by alternately energising and de-energising coils 416 and 418 a reciprocating motion of armature 420 may be achieved.

Linear Motion

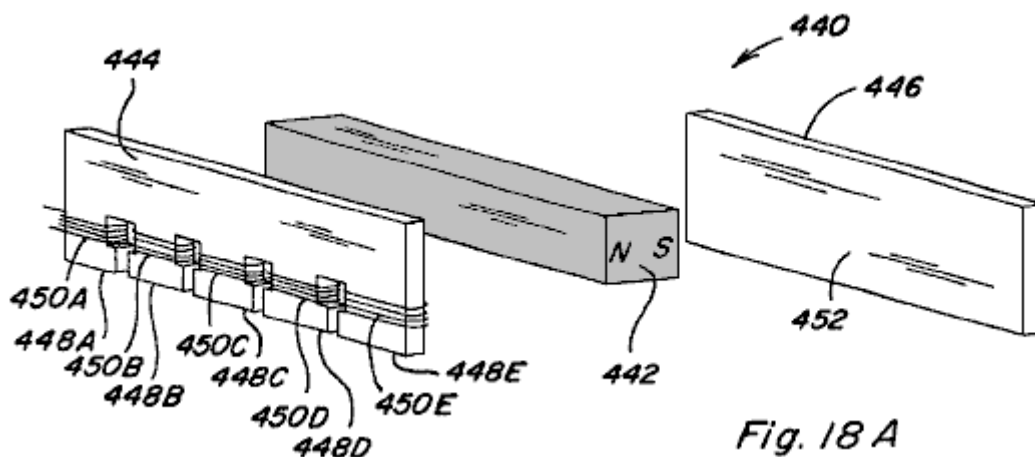

Referring now to **Figs.18A-18E**, linear motion in accordance with the present invention is described. In particular, a permanent magnet control component 440 including a permanent magnet 442 with a pole piece 444 positioned against its north pole face and a pole piece 446 positioned against its south pole face is shown in an exploded view in **Fig.18A** and assembled in **Fig.18B**.

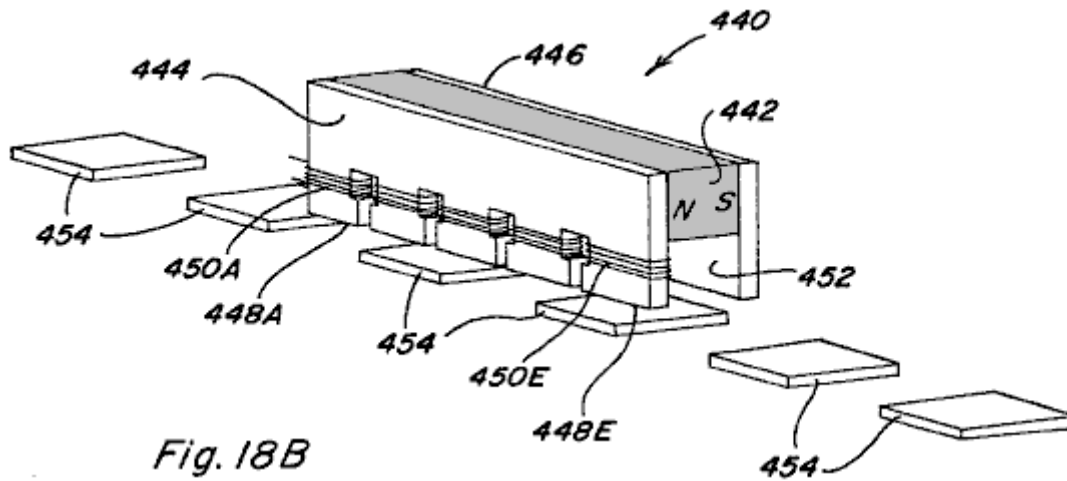
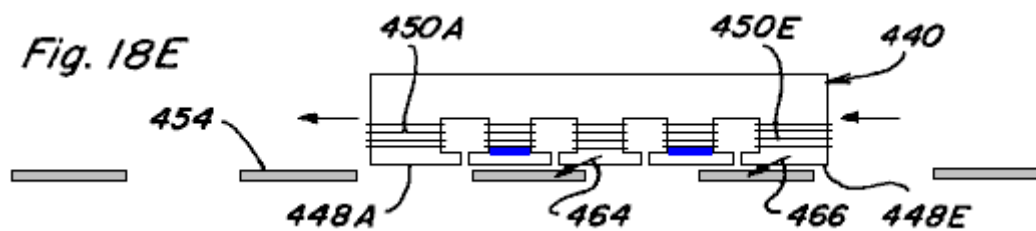
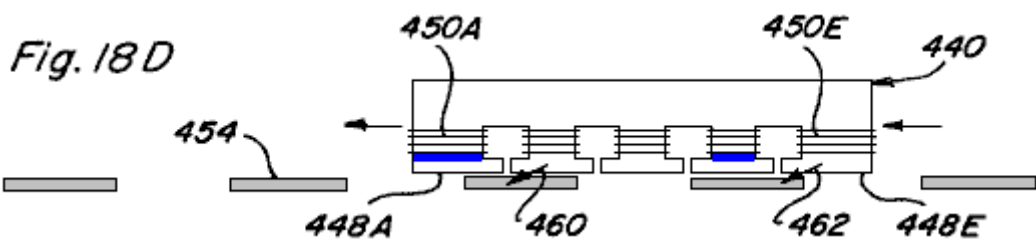
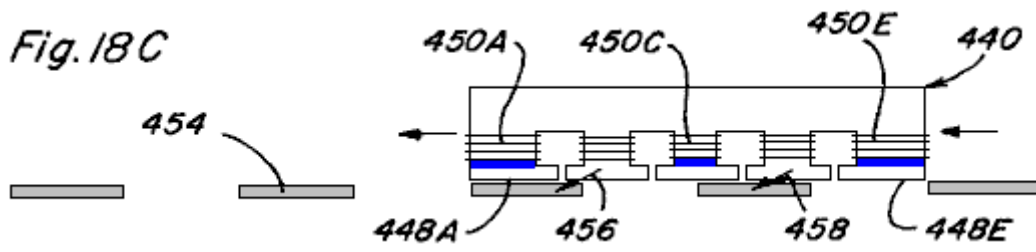

Fig. 18B

Pole piece 444 includes five path portions 448A-448E which extend beyond the edge of the north pole face of permanent magnet 442 to one side of it and at respective positions along its length, and it has path portion 448A-448E each with a control coil 450A-450E positioned around them. Pole piece 446 includes one portion 452 extending beyond the edge of the south pole face of permanent magnet 442 to the one side of it, and this portion 452 extends along the entire length of permanent magnet 442. A number of armatures 454 define a path of relative movement between permanent magnet control component 440 and such armatures 454, and by providing timed energisation of given control coils 450A-450E such relative movement can be achieved.



The sequence of side views depicted in Figs.18C-18E illustrate such relative movement, with coils 450A, 450C and 450E being energised in an opposing manner simultaneously in Fig.18C, with coils 450A and 450D being energised simultaneously in an opposing manner in Fig.18D, and with coils 450B and 450D being energised simultaneously in an opposing manner in Fig.18E.

In Fig.18C, magnetic flux will only flow along path portions 448B and 448C of pole piece 444 causing resultant magnetic coupling forces depicted by arrows 456, 458 which act to move permanent magnet control component 440 to the left, assuming armatures 454 are fixed. Similarly, due to the timing of subsequent coil energisation resultant magnetic forces depicted by arrows 460, 462 in Fig.18D and arrows 464, 466 in Fig.18E act to continue movement of permanent magnet control component 440 to the left. Thus, if permanent magnet control component 440 were fixed to a device or structure, controlled movement of the device or structure along the path defined by armatures 454 could be achieved. Conversely, if permanent magnet control component 440 were fixed and armatures 454 were located on a device or structure, controlled movement of the device or structure

could also be achieved. It is also easily recognised that by varying the coil energisation sequence and timing relative movement in the opposite direction can be achieved. Further, if the permanent magnet was doughnut shaped and the armatures were arranged in a circumferential pattern, rotary motion would likewise be achievable.

Rotary Motion

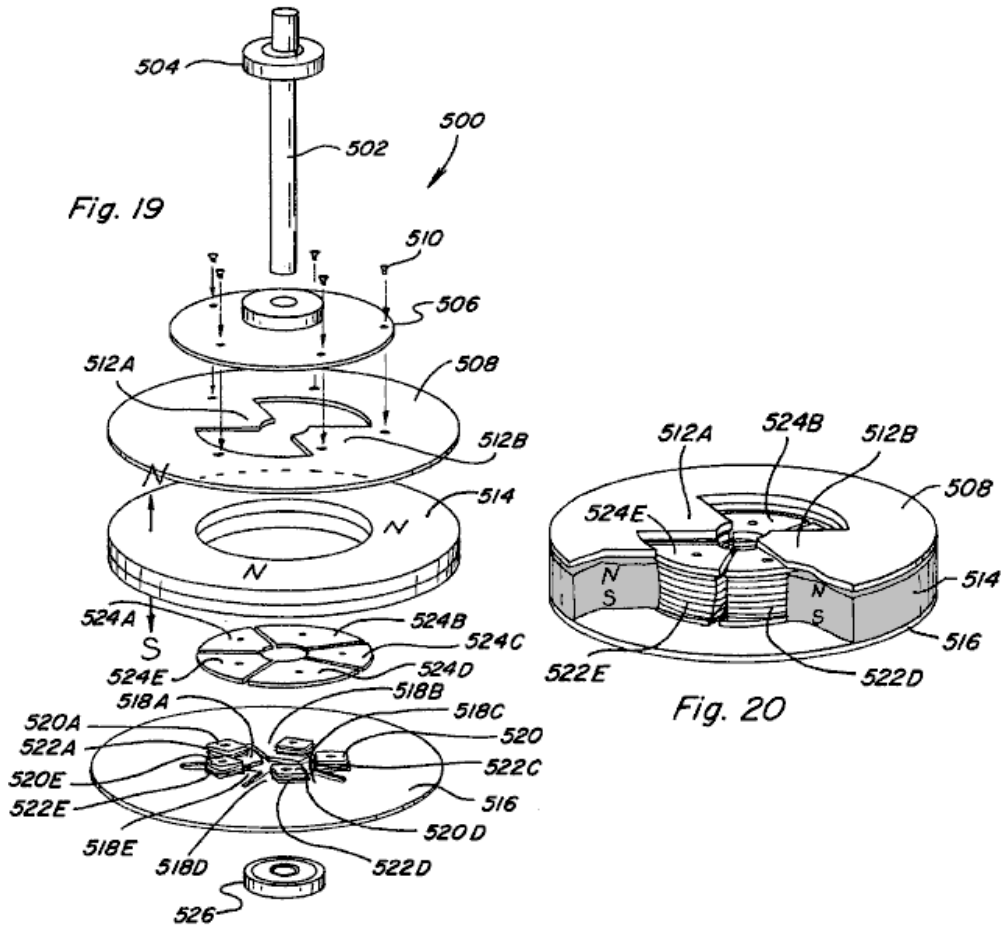

One embodiment of a rotary motion device or motor **500** which incorporates various permanent magnet flux control aspects of the present invention is shown in the exploded view of **Fig.19** and in the partial assembled view of **Fig.20**. Motor **500** includes a rotor assembly which includes a shaft **502** and associated upper bearing **504**, a non-magnetic disk member **506** mounted for rotation with shaft **502**, and a rotor pole piece **508** which is mounted for rotation with disk member **506** such as by the use of screws **510**. Rotor pole piece **508** includes a ring-shaped portion having two inwardly extending magnetic flux path portions **512A** and **512B**. A stator assembly of motor **500** includes a doughnut or ring-shaped permanent magnet **514** having an upwardly directed north pole face positioned adjacent and in close proximity to rotor pole piece **508**, and a downward directed south pole face positioned adjacent and in contact with a stator pole piece **516**. Stator pole piece includes a ring-shaped portion having five inwardly projecting path portions **518A-518E**. Each path portion includes a respective winding post **520A-520E** extending therefrom and having a respective control coil **522A-522E** wound on it. Stator pole piece faces **524A-524E** are which can be positioned on respective winding posts **518A-518B** and, as shown in the partial assembly of **Fig.20**, are substantially aligned with the top surface of permanent magnet **514** so as to be which can be positioned adjacent rotor path portions **512A** and **512B** when aligned therewith. Each of winding posts **518A-518E** and stator pole piece faces are formed of magnetic material, and although shown as separate pieces, an integral, one piece stator could be formed with similar winding posts and pole piece faces machined on it. Lower bearing **526** is also shown.

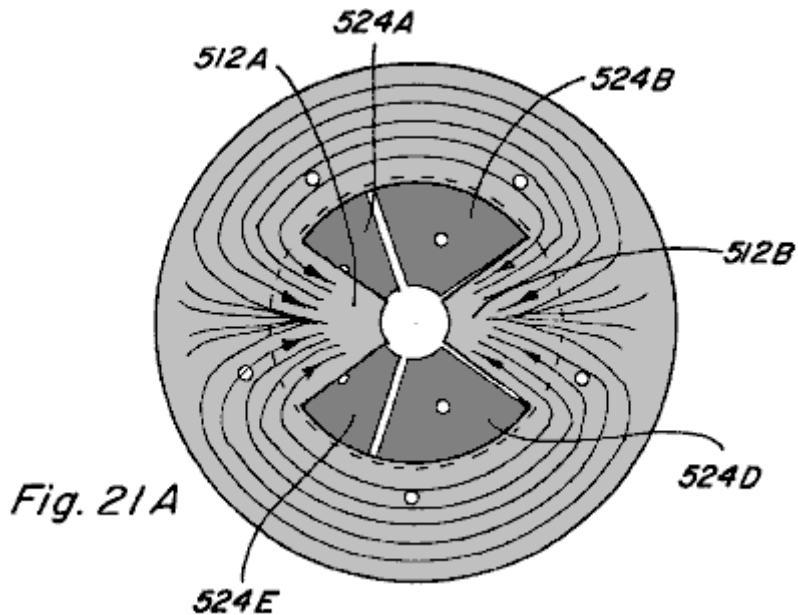

Figs.21A-21E illustrate top views of the partial assembly of **Fig.20** with magnetic flux shown. In **Fig.21A** magnetic flux travel when none of coils **522A-522E** are energised is depicted. Disregarding leakage flux, due to the low-reluctance path provided by rotor pole piece path portions **512A** and **512B**, the majority of magnetic flux from the north pole face of permanent magnet **514** will travel radially inward along one of such path portions before passing downward through the stator assembly and returning to the south pole face of permanent magnet **514**. It is noted that rotor pole piece **508** includes two path portions and stator pole piece **516** includes five path portions such that rotor pole piece path portions **512A** and **512B** will always be skewed relative to the stator pole piece faces **524A-524E**. Only one rotor pole piece path portion can directly align with a stator pole piece face at a given time. By alternately energising the control coils of each of the stator pole piece paths, rotary motion of the rotor may be achieved.

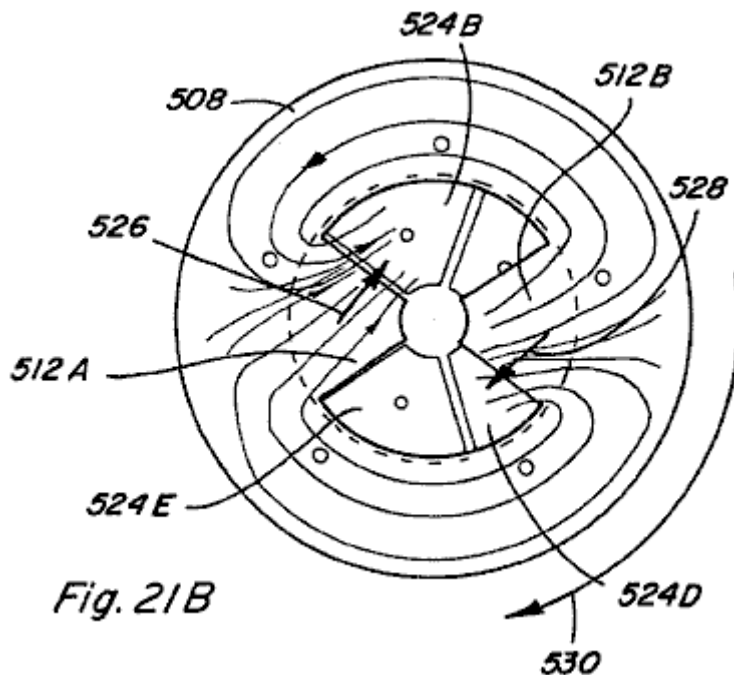

In particular, referring to **Figs.21B-21D**, an energising sequence which results in such rotary motion is described. In **Fig.21B**, control coils **522A** and **522C** are energised in a permanent magnet flux opposing manner. Permanent magnet magnetic flux travelling along rotor pole piece path portion **512A** tends to traverse to stator pole piece face **524B** causing a magnetic coupling force indicated by arrow **526**. Likewise, permanent magnet flux travelling along rotor pole piece path portion **512B** tends to traverse to stator pole piece face **524D** causing a magnetic coupling force indicated by arrow **528**. The result is rotation of rotor pole piece **508** in a clockwise direction as indicated by arrow **530**.

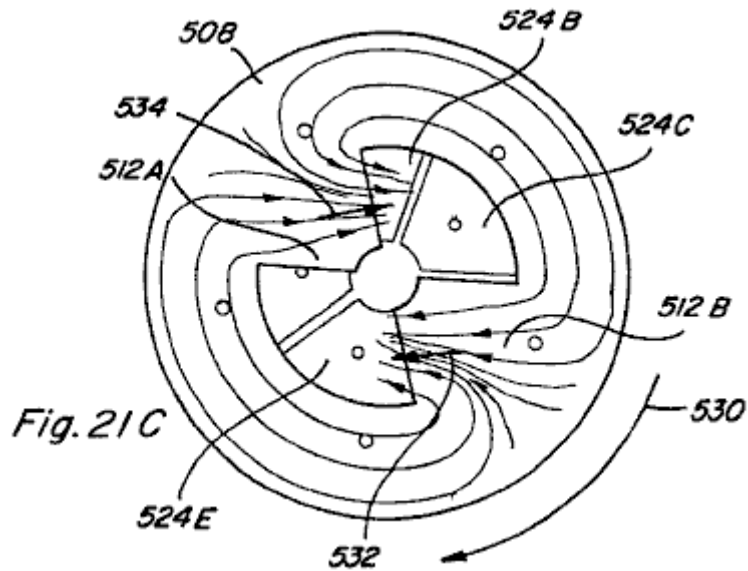

Referring to **Fig.21C**, just after rotor pole piece path portion **512B** is no longer aligned with stator pole piece face **524D**, control coil **522C** is de-energised and control coil **522D** is energised in an opposing manner such that the permanent magnet flux travelling along rotor pole piece path **512B** tends to traverse to stator pole piece face **524E** resulting in magnetic coupling force indicated by arrow **532**. Control coil **522A** remains energised such that a magnetic coupling force indicated by arrow **534** results. Accordingly, clockwise rotation of rotor pole piece **508** is continued.

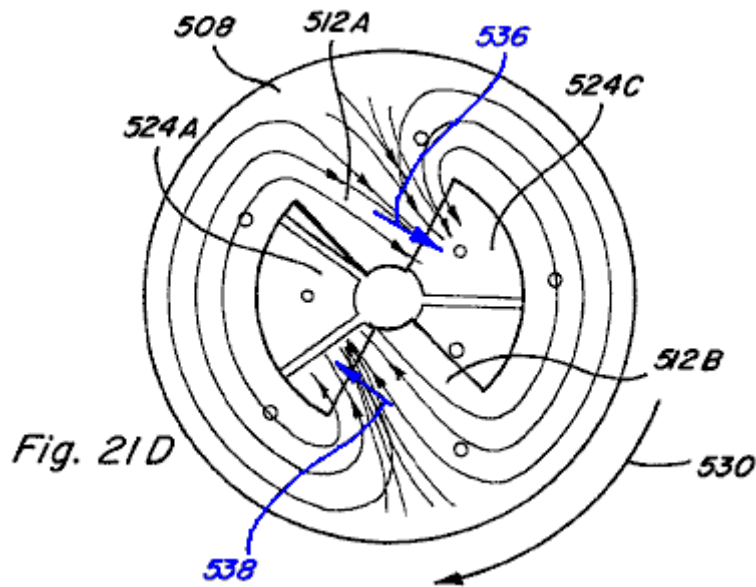

In **Fig.21D**, just after rotor pole piece path portion **512A** is no longer aligned with stator pole piece face **524B**, control coil **522A** is de-energised and control coil **522B** is energised in a permanent magnet magnetic flux opposing manner such that the permanent magnet magnetic flux travelling along rotor pole piece path **512A** tends to traverse to stator pole piece face **524C** such that a magnetic coupling force indicated by arrow **536** results. Control coil **522D** remains energised such that a magnetic coupling force indicated by arrow **538** results, and clockwise rotation of rotor pole piece **508** is continued.

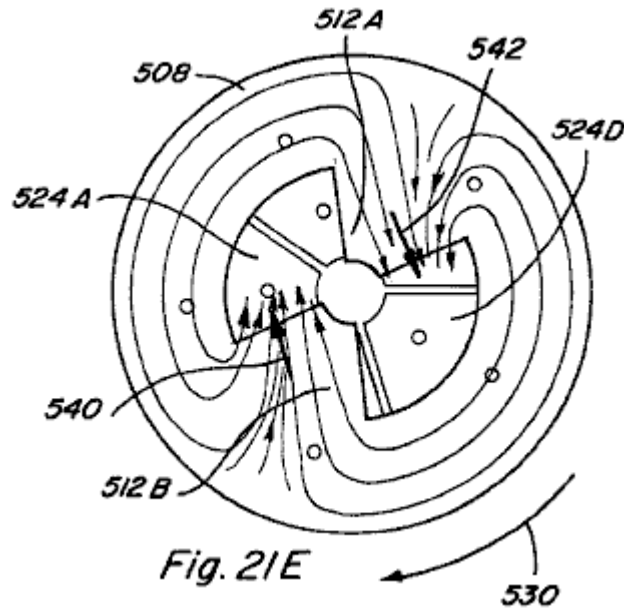

As shown in **Fig.21E**, just after rotor pole piece path portion **512B** is no longer aligned with stator pole piece face **524E**, control coil **522D** is de-energised and control coil **522E** is energised in a permanent magnet magnetic flux opposing manner such that the permanent magnet magnetic flux travelling along rotor pole piece path **512B** tends to traverse to stator pole piece face **524A** such that a magnetic coupling force indicated by arrow **540** results. Control coil **522B** remains energised such that a magnetic coupling force indicated by arrow **542** results, and clockwise rotation of rotor pole piece **508** is continued.

Thus, by alternating energising and de-energising control coils **522A-522E**, in a predetermined timed sequence based upon rotation of the rotor assembly, continued rotation movement of rotor pole piece **508** may be achieved. Such an energisation/de-energisation scheme can be achieved utilising circuitry common in the art, such as the control circuitry described in Applicant's U.S. Pat. Nos. 5,463,263 and 5,455,474, as well as various of the circuit configurations described below.

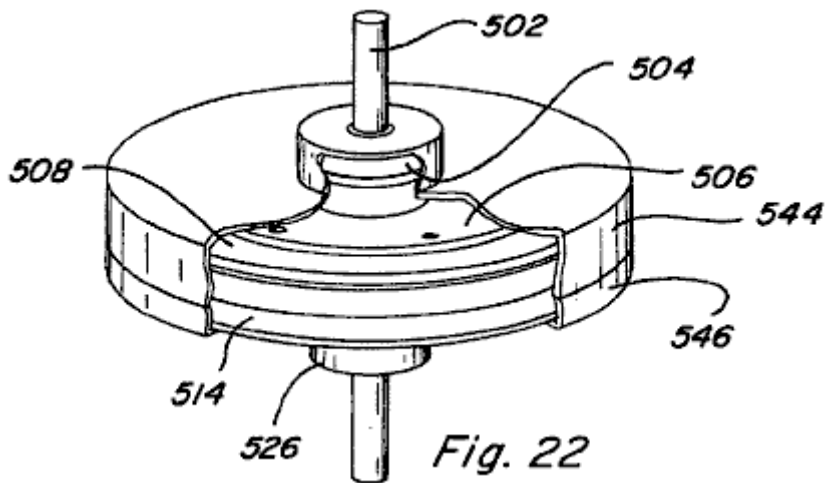

Referring now to **Fig.22**, an assembled view of rotary motor **500** is shown including a housing or cover formed by an upper housing member **544** and a lower housing member **546**, with portions of each housing member cut away to expose motor structure described above. It is recognised that such housing members **544** and **546** should be constructed from a non-magnetic material, and likewise that motor shaft **502** and bearings **504**, **526** should be constructed from a non-magnetic material.

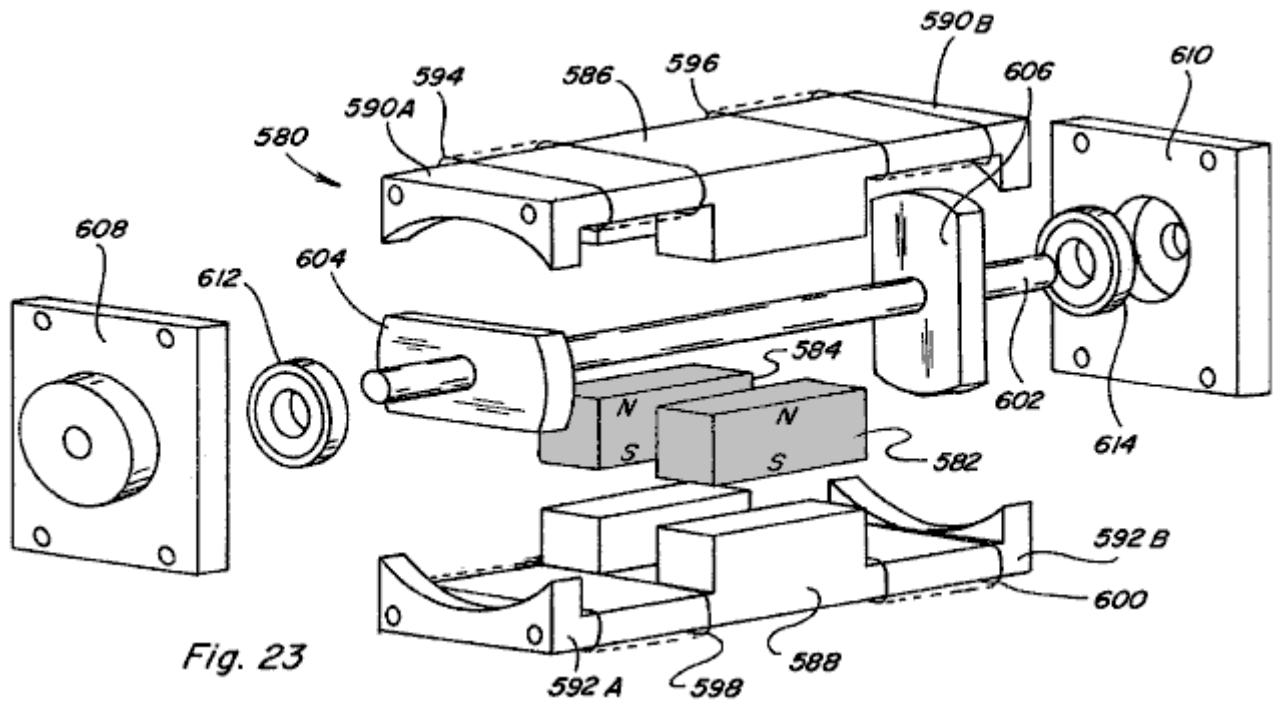

Fig. 23

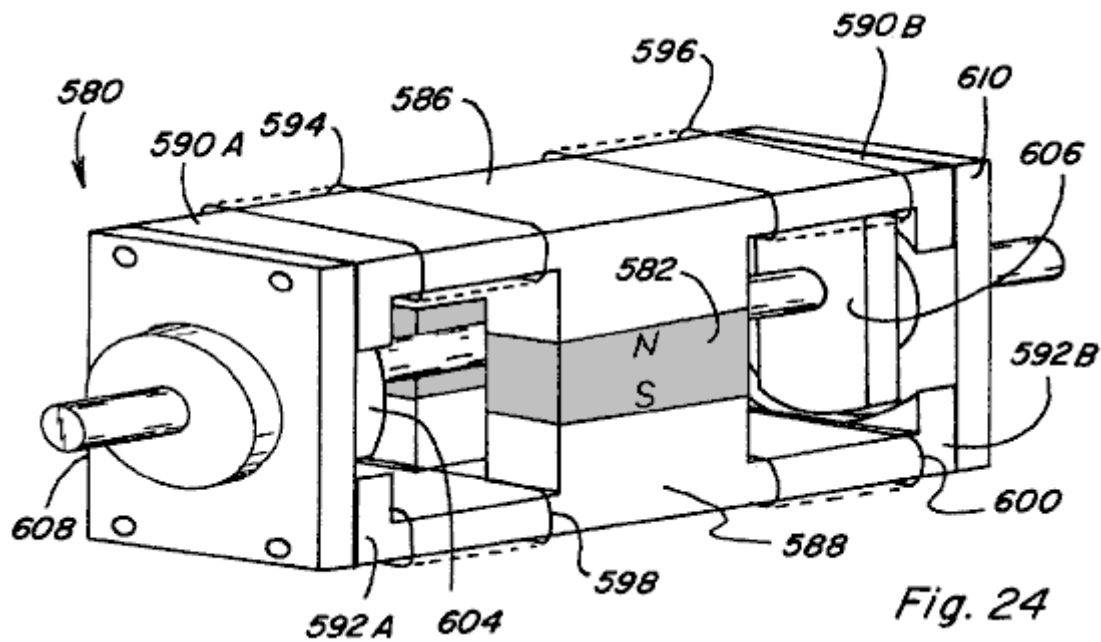
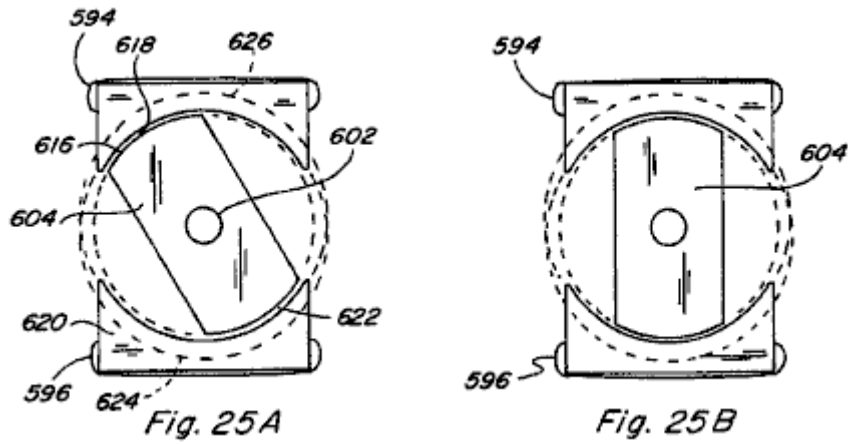

Fig. 24

In another embodiment, a rotary motion device or motor 580 in accordance with the present invention is shown in an exploded perspective view in Fig.23 and in an assembled perspective view in Fig.24. Two spaced permanent magnets 582 and 584 are positioned between stator pole pieces 586 and 588. Stator pole piece 586 includes two path portions 590A and 590B extending away from permanent magnets 582, 584 in opposite directions. Likewise, stator pole piece 588 includes two path portions 592A and 592B extending away from permanent magnets 582, 584 in opposite directions and which can be aligned with stator pole piece path portions 590A and 590B. Control coils 594, 596, 598, and 600 are each positioned along a stator pole piece path portion as shown. A non-magnetic shaft 602 includes a pair of matching elongated rotor members 604 and 606, formed of magnetic material, mounted at spaced locations on the shaft and being set at an angle to each other, shaft 602 passing between spaced permanent magnets 582 and 584. Two end cap members 608 and 610, made from non-magnetic material, are attached to the ends of stator pole pieces 586 and 588 and are configured for receiving shaft 602 and respective bearings 612 and 614.



The ends of the stator pole pieces **506** and **508** are configured for a given desired coupling relationship with rotor members **604** and **606**. For example, as shown in the exemplary end views of **Fig.25A** and **Fig.25B**, with end cap **608** removed, the end of stator pole piece **586** may include an curved portion **616** which is configured to create a variable-reluctance air gap **618** with elongated rotor member **604**. The end of stator pole piece **588** includes an curved portion **620** which is also configured to create a variable-reluctance air gap **622** with rotor member **604**.

In particular, portion **618** includes a circumferential curvature which has a centre point offset below the axis of rotation of shaft **602** and rotor member **604** as indicated by circle **624** shown in shadow. Similarly, portion **620** includes a circumferential radius of curvature which has a centre point offset above the axis of rotation of shaft **602** and rotor member **604**. When magnetic flux is passing along the path which includes a given end of the assembly, maximum coupling between the rotor member and stator pole pieces occurs when the rotor is positioned as shown in **Fig.25B**. Accordingly, the illustrated rotor member and stator pole piece configurations of themselves do not provide any skewing to the direction of rotation of the rotor assembly.

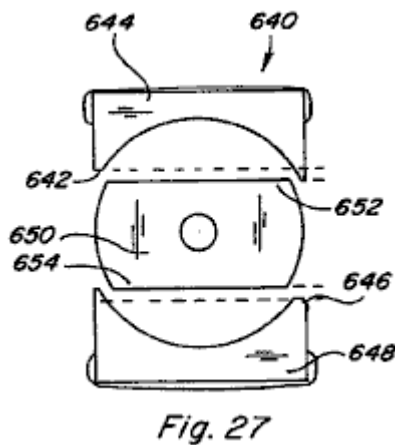
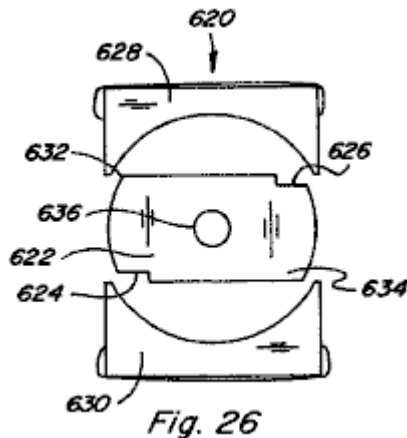

In this regard, various configurations for the rotor and ends of the stator pole piece are shown in the end views of **Figs.26-28**, which configurations provide skewing the direction of rotation. In particular, in device **620** of **Fig.26** a

rotor member 622 having notches 624 and 626, which notches provide for greater magnetic coupling with the stator pole pieces 628 and 630 at corners 632 and 634 such that rotation is skewed in the clockwise direction. If notches were instead located at corners 632 and 634, skewed rotation in the counterclockwise direction would be the result. In device 620 such counterclockwise rotation could also be achieved by removing rotor 622 from shaft 636, flipping it end to end, and replacing it on shaft 636.

In the device 640 of Fig.27, a portion 642 of the curved end portion of stator pole piece 644 is removed and a portion 646 of the curved end portion of stator pole piece 648 is removed. This configuration results in greater magnetic coupling between rotor member 650 and stator pole piece 644 at corner 652, and greater magnetic coupling between rotor member 650 and stator pole piece 648 at corner 654, such that rotation is skewed in the counterclockwise direction. Clockwise rotation could be achieved by instead modifying the opposite side of stator pole pieces 644 and 648.

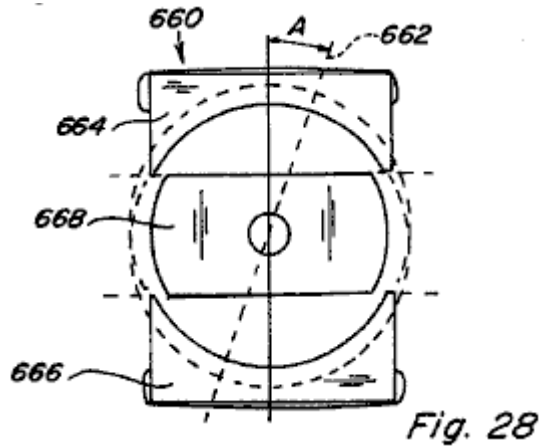
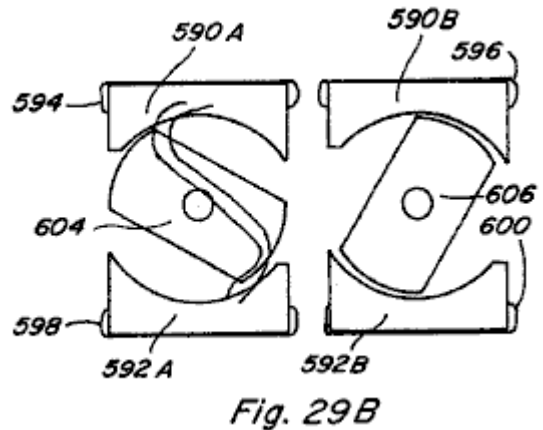
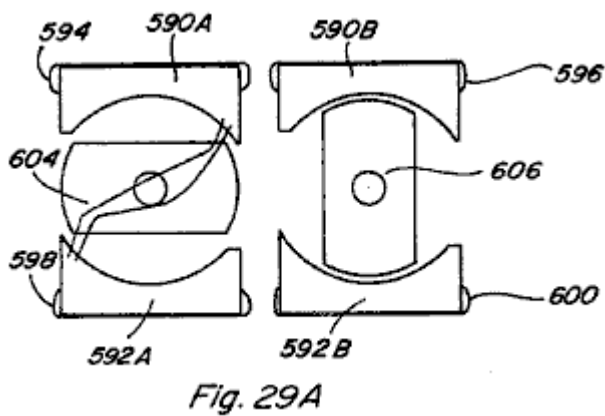

Fig.28 depicts an end view of a device 660 in which the axis 662 of the curved end portion of upper stator pole piece 664 and lower stator pole piece 666 is placed at an angle A as shown. This configuration creates an unequal variable-reluctance air gap where opposite corners of rotor member 668 are closer to stator pole pieces 664 and 666. Further, the angle at which maximum magnetic coupling between rotor member 668 and stator pole pieces 664 and 666 occurs is retarded by angle A. Rotation would be in the counterclockwise direction for the illustrated configuration.



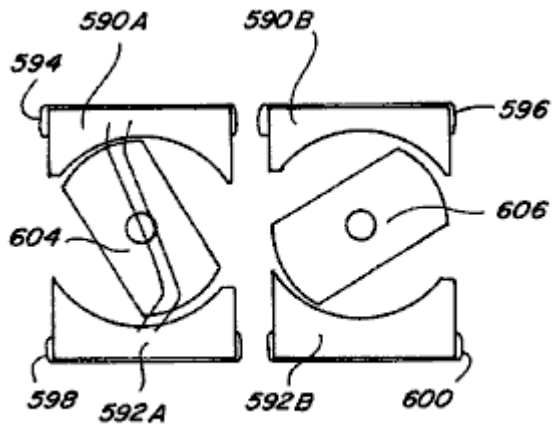

Fig. 29 C

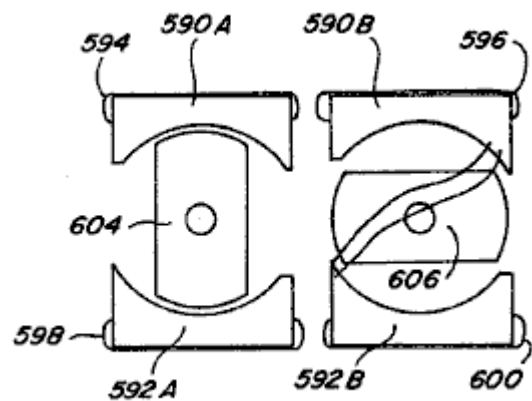
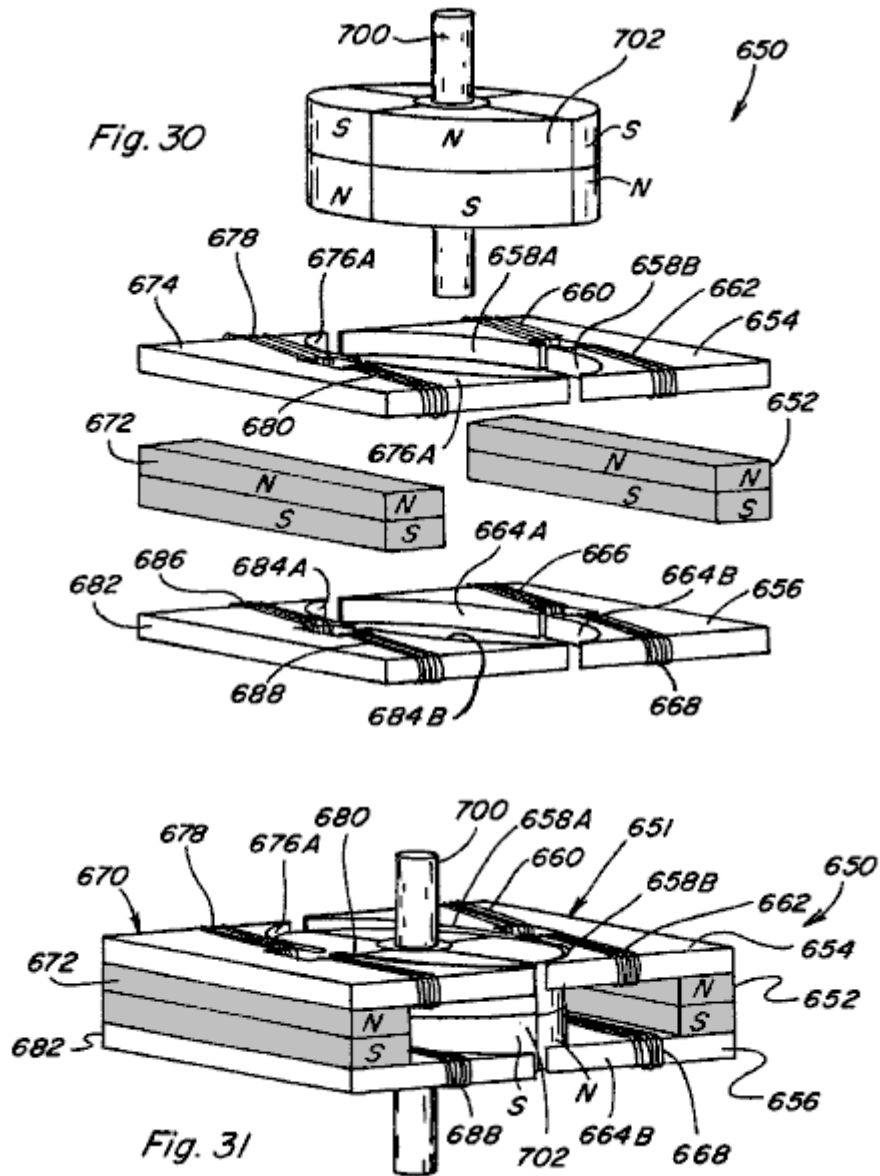

Fig. 29 D

Referring again to motor 580 of Figs.23-25, rotary motion of such device is depicted in the end views of Figs.29A-29D. In each end view the end cap has been removed to show rotation of the rotor members and in each of Figs.29A-29D an end view depicting rotor member 604 and an end view depicting rotor member 606 are shown side-by-side. In Fig.29A, rotor member 604 is defined as being at zero degrees and rotor member 606 is defined as being at ninety degrees. Control coils 594, 598 are energised in a permanent magnet magnetic flux aiding manner such that no magnetic flux passes through stator pole piece path portions 590B and 592B. This allows rotor member 606 to move out of its ninety degree position and the magnetic coupling between rotor member 604 and stator pole piece path portions 590A and 592A will cause rotation to the position shown in Fig.29B and then Fig.29C. When rotor member 604 reaches the ninety degree position shown in Fig.29D control coils 594, 598 are de-energised and control coils 596, 600 are energised in a permanent magnet magnetic flux aiding manner causing rotation to continue due to the magnetic coupling between rotor member 606 and stator pole piece path portions 590B and 592B. Thus, by alternately energising the control coils of each path with every ninety degree rotation of rotor members 604 and 606, continuous rotary motion is achieved.

The initial direction of rotation can be controlled by the circuit means used to energise control coils 594, 598 and 596, 600, which circuit means includes circuitry for detecting the angular position of the rotor members. In particular, if rotor members 604 and 606 are at rest in the position shown in Fig.29A, and coils 594, 598 are energised in an aiding manner, rotation may be clockwise or counterclockwise. If the desired direction is clockwise but upon energisation of coils 594, 598 the rotor members begin to move counterclockwise, the detection circuitry will immediately de-energise coils 594, 598 and energise coils 596, 600 so that the clockwise direction is achieved.

Further, bypasses around permanent magnets 582 and 584 could be provided in rotary motion device 580, such as those shown in Fig.12, and rotor members 604 and 606 could be formed by permanent magnets so as to take advantage of energising the control coils in an exceeding manner.



A third embodiment of a rotary motion device or motor **650** is shown in the exploded partial perspective view of **Fig.30** and in the assembled partial perspective view of **Fig.31**. In motor **650** the stator assembly includes a control component **651** including a permanent magnet **652** having a stator pole piece **654** positioned adjacent to one pole face of the magnet and a stator pole piece **656** positioned adjacent to the opposite pole face. Stator pole piece **654** includes a path portion **658A** extending to one side of permanent magnet **652** and a path portion **658B** extending to the one side thereof and spaced from first path portion **658A**. Control coils **660** and **662** are positioned along respective stator pole piece path portions **658A** and **658B**.

In the same way, stator pole piece **656** includes path portions **664A** and **664B** which extend in a similar manner from it so as to be aligned with stator path portions **658A** and **658B** respectively. Control coils **666** and **668** are positioned along respective stator pole piece path portions **664A** and **664B**. Positioned opposite, and facing control component **651**, is a similar control component **670** including permanent magnet **672** stator pole piece **674** with path portions **676A** and **676B** having the control coils **678** and **680**, and stator pole piece **682** with path portions **684A** and **684B** having their control coils **686** and **688**. The end of each of the pole piece path portions **658A**, **658B**, **664A**, **664B**, **676A**, **676B**, **684A**, and **684B** is of a generally curved configuration.

A rotor assembly of motor **650** includes a non-magnetic shaft **700** having a permanent magnet rotor member **702** mounted on it and which rotates with it. Permanent magnet rotor member **702** is generally ring-shaped and segmented to include distinct north and south pole faces which reverse about every ninety degrees around them. When assembled, the top and bottom surfaces of permanent magnet rotor member **702** align with pole pieces **654**, **656**, **674**, and **682** of the stator assembly and are preferably configured so that there is a minimal gap between the outer surface of permanent magnet rotor member **702** and the curved surfaces of the pole piece path portions.

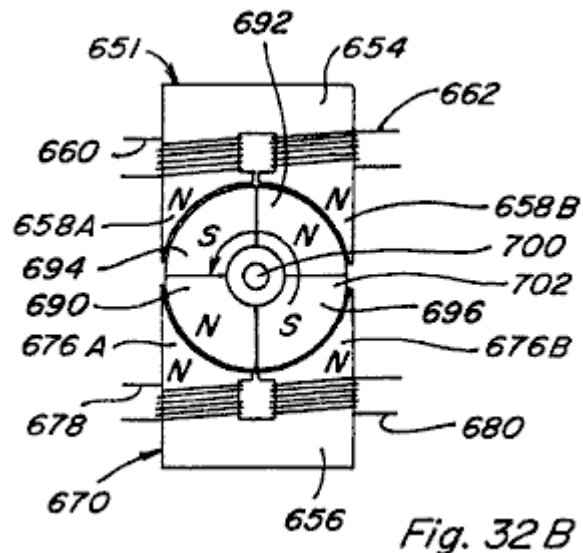
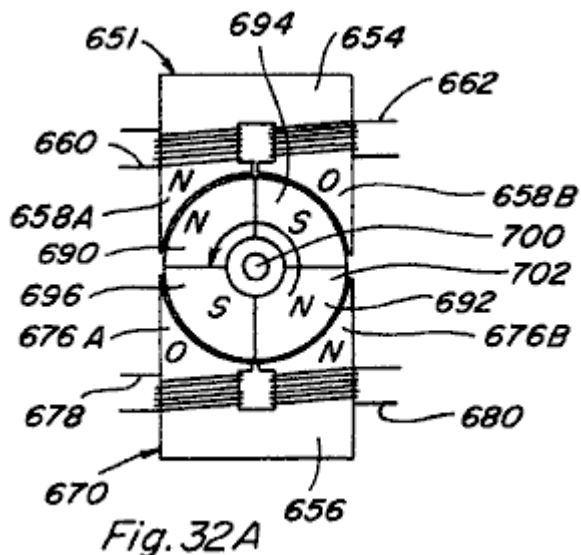

Rotation of device 650 can be achieved by controlled, timed energising and de-energising of control coils 660, 662, 666, 678, 680, 686, and 688. Exemplary rotation is demonstrated with reference to the top views of Figs.32A-32B which depict counterclockwise rotation of permanent magnet rotor member 702 through one-hundred and eighty degrees. In Fig.32A stator pole piece path portion 658A of component 651 is active and stator pole piece path portion 658B is not active, which may be achieved by energising control coil 660 in a permanent magnet magnetic flux aiding manner or by energising control coil 662 in a permanent magnet magnetic flux opposing manner. Stator pole piece path portion 676B of component 670 is active and stator pole piece path portion 676A is not active, which may be achieved by energising control coil 680 in a permanent magnet magnetic flux aiding manner or by energising control coil 678 in a permanent magnet magnetic flux opposing manner.

Thus, portions 690 and 692 of permanent magnet rotor member 702, which both have a north magnetic polarity, will be repelled by the north polarity of stator pole piece path portions 658A and 676B aligned with it. Portions 694 and 696 of permanent magnet rotor member 702, both of which have a south magnetic polarity, will be attracted to the active path portions 658A and 676B. At the instant that rotor member portion 694 becomes aligned with stator pole piece path portion 658A, as shown in Fig.32B, all coils are de-energised such that all pole piece path portions will be active as shown. Pole piece path portions 658B and 676A are then kept active while pole piece path portions 658A and 676B are made inactive. This is achieved by energising control coils 662 and 678 in a permanent magnet magnetic flux aiding manner or by energising control coils 660 and 680 in a permanent magnet magnetic flux opposing manner. Rotor member portions 690 and 692 will again be repelled by the north polarity of path portions 658B and 676A aligned with it so that rotation of permanent magnet rotor 702 is continued.

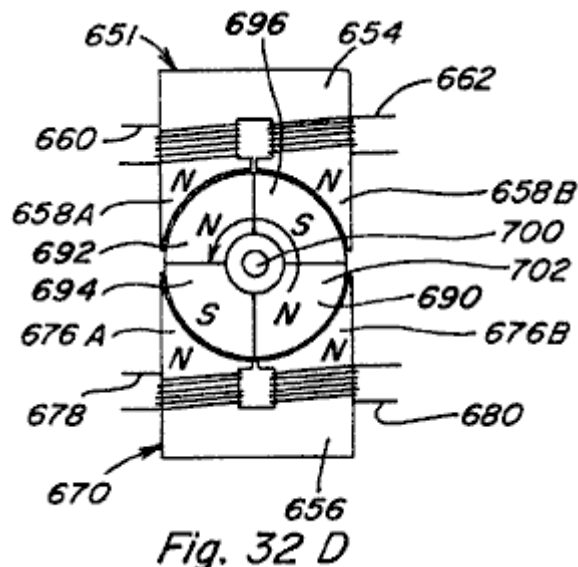
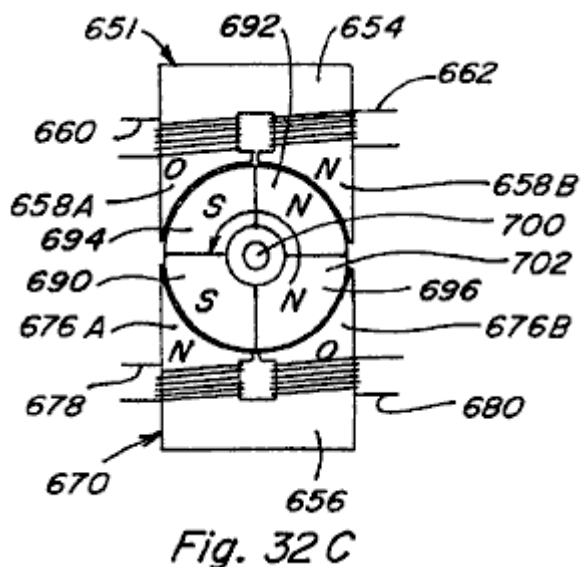

In Fig.32D all coils are shown de-energised when rotor portion 692 aligns with pole piece path portion 658A. By continuing this timed sequence of energisation and de-energisation of the control coils, continued rotary movement is achieved. As explained above, the initial direction of rotation can be controlled by circuit means

which detects the initial direction of permanent magnet rotor 702 and immediately alters the coil energisation scheme if the initial direction is incorrect.

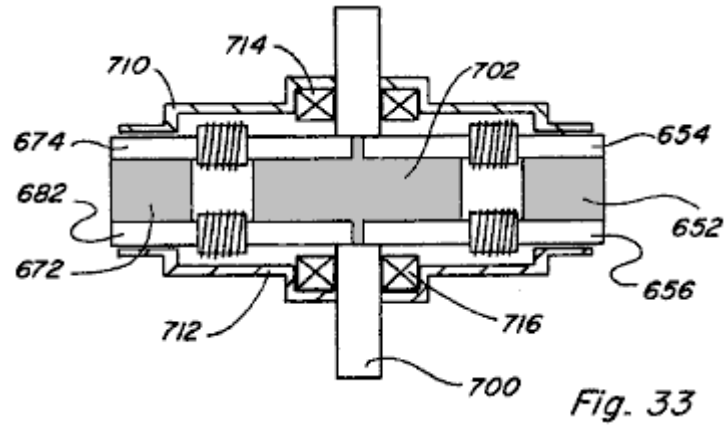

Fig. 33

A side view of assembled motor 650 is shown in Fig.33 and includes an upper housing or enclosure portion 710, a bottom housing portion 712, upper bearing 714, and a lower bearing 716.

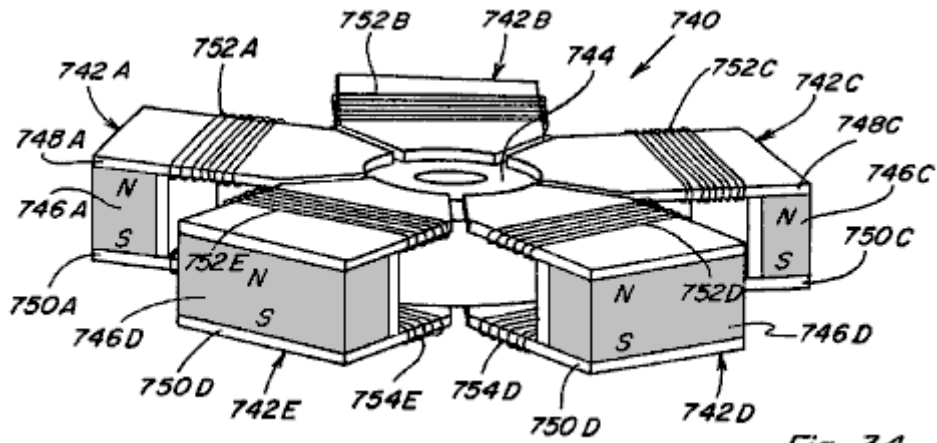

Fig. 34

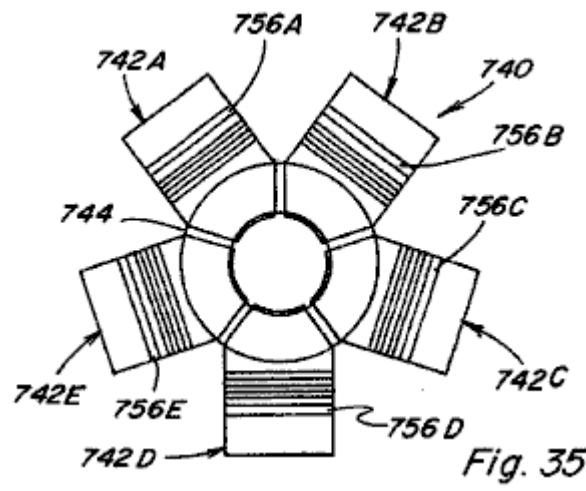

Fig. 35

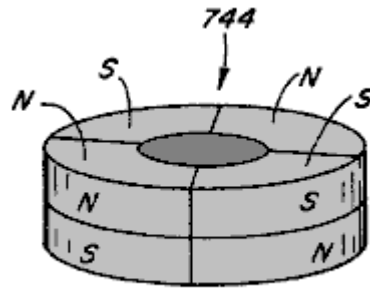

Fig. 36

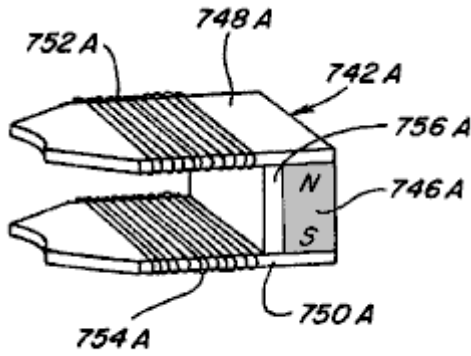

Fig. 37

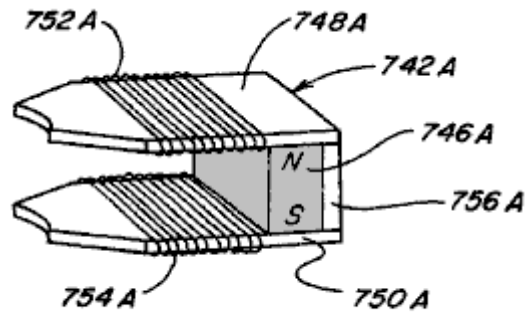

Fig. 38

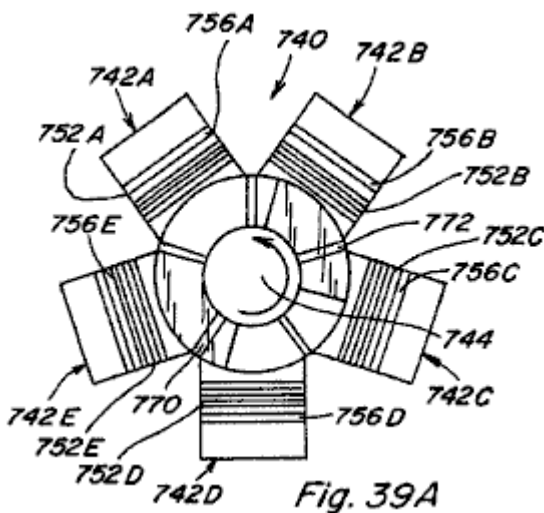

Fig. 39A

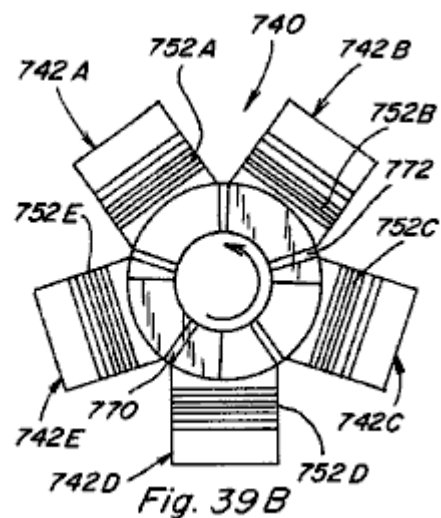

Fig. 39B

A fourth embodiment of a rotary motion device or motor 740 is illustrated in Figs.34-39. Motor 740 includes five stator control components 742A-742E positioned around a ring shaped permanent magnet rotor member 744 (Fig.36). As shown with reference to component 742A in Fig.37, each stator component 742A includes a permanent magnet 746A with an upper pole piece 748A positioned adjacent to one pole face and a lower pole piece 750A positioned adjacent to the opposite pole face. Control coils 752A, 754A are positioned along respective pole pieces 748A, 750A. A bypass 756A extends from pole piece 748A to pole piece 750A and is positioned between permanent magnet 746A and control coils 752A, 754A. Alternatively, bypass 756A could be provided on the opposite side of permanent magnet 746A as shown in Fig.38. Although not shown, it is anticipated that permanent magnet rotor member 744 would be mounted on an axis for rotation with it and that a motor housing or enclosure could be provided, such as shown in relation to motor 650 of Fig.33.

Referring to the top views of Figs.39A-39D, rotary motion of rotor member 744 is depicted by the sequence of views. Regions 770 and 772 in Figs.39A-39D represent the magnetic north regions of the top of permanent magnet rotor 744. In Fig.39A control coils 752E and 752C are energised in a permanent magnet aiding and exceeding manner such that regions 770 and 772 of permanent magnet rotor 744 are repulsed by components 742E and 742C while permanent magnet motor regions 774 and 776 are attracted by components 742E and 742C. The resultant coupling forces act to move permanent magnet rotor in a counterclockwise direction to the location shown in Fig.39B. Just after permanent magnet rotor region 772 passes the point shown in Fig.39C, control coil 752B is energised in a permanent magnet aiding and exceeding manner, while control coils 752E and 752C also remain energised, and counterclockwise rotation of permanent magnet rotor 744 is continued. Just

after permanent magnet rotor region 772 passes by control component 742C control coil 752C is de-energised, while control coils 752E and 752B remain energised, so as to continue counterclockwise rotation. Then, just after permanent magnet rotor region 770 reaches the location shown in Fig.39D control coil 752D is energised in a permanent magnet flux aiding and exceeding manner, while coils 752E and 752B remain energised, so as to continue counterclockwise rotation. Thus, as in the other embodiments, repeated and timed energisation and de-energisation of the control coils produces the desired rotational movement.

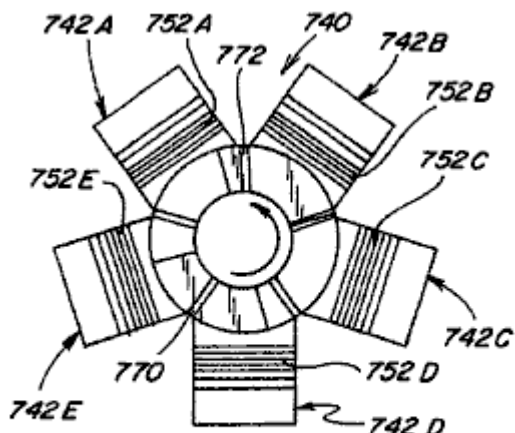

Fig. 39 C

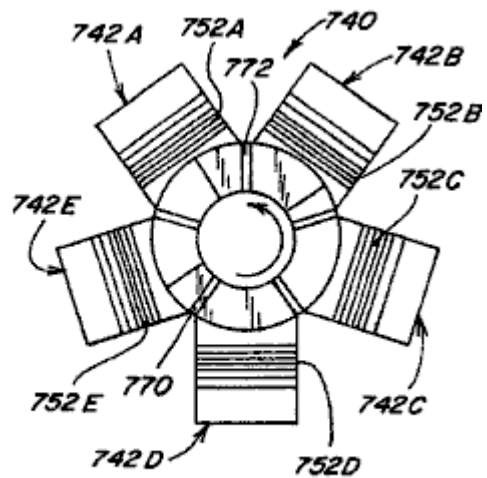

Fig. 39 D

In terms of controlling the energisation of coils in the devices described above, various electronic control circuit/switching means and electromechanical control circuit/switching machines are depicted in Figs.40-44. In circuit 800 of Fig.40 a given coil 802 is placed in series between an electrical energy source 804 and a power MOSFET 806. An LED 808 is connected to electrical energy source 804 through resistor 810 and is positioned to impinge upon a phototransistor 812 which is connected in series with resistor 814. A control input of MOSFET 806 is connected between phototransistor 812 and resistor. Accordingly, when LED 808 activates phototransistor 812 the voltage drop across resistor 814 activates, or turns ON, MOSFET 806 and coil 802 is energised. Timed energisation of coil 802 is provided by mounting an interrupter 816, such as shown in Fig.42, to the shaft 816 of the motor device to be controlled, such that as interrupter 814 rotates with shaft 816 coil 802 is alternately energised and de-energised. In a device with a plurality of coils a corresponding plurality of LED/photoreistor pairs may be provided.

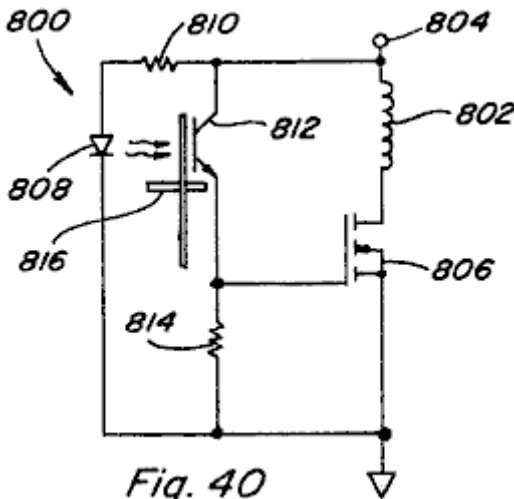

Fig. 40

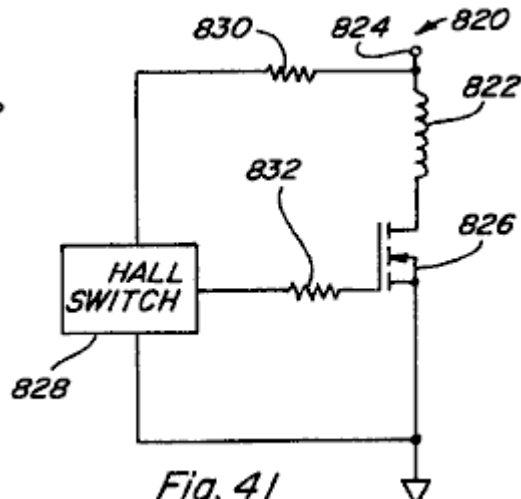
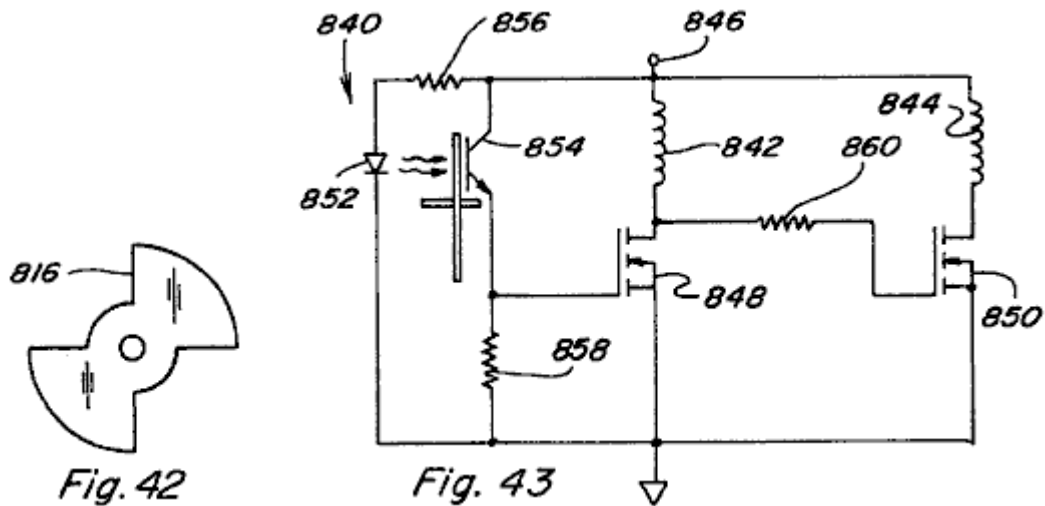
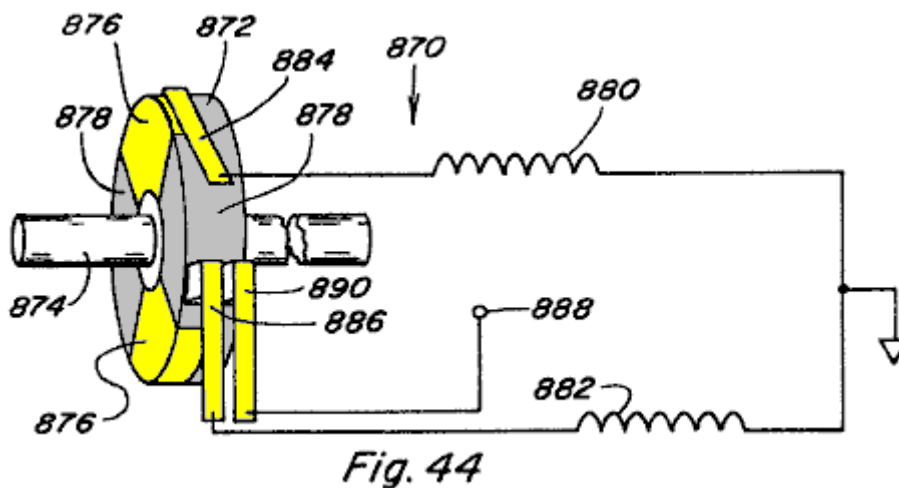

Fig. 41

In circuit 820 of Fig.41 a coil 822 is positioned between electrical energy source 824 and power MOSFET 826. A hall switch 828 is connected in series with resistor 830. Hall switch 828 is also connected to the control input of MOSFET 826 through resistor 832. In a given device hall switch 828 would be positioned to react to a change in magnetic flux so as to control the ON/OFF switching of MOSFET 826, and thus the alternate energisation and de-energisation of coil 822.



In Fig.43 a circuit 840 for controlling two coils in an opposite manner is provided such that when coil 842 is energised coil 844 is de-energised, and such that when coil 842 is de-energised coil 844 is energised. Both coils 842 and 844 are connected in series between electrical energy source 846 and respective power MOSFETs 848 and 850. An LED 852 and phototransistor 854 arrangement is provided, LED connected in series with resistor 856 and phototransistor connected in series with resistor 858. When LED 852 turns phototransistor 854 ON the voltage drop across resistor 858 turns MOSFET 848 ON and coil 842 is energised. At that time the voltage applied at the control input of MOSFET 850 will be low and therefore MOSFET 850 will be OFF and coil 844 will be de-energised. When interrupter 814 blocks LED 852, phototransistor 854 is turned OFF and MOSFET 848 is likewise turned OFF. The control input of MOSFET 850 is therefore pulled high through resistor 860 and MOSFET 850 is turned ON such that coil 844 is energised.



In Fig.44 a system 870 including member 872 mounted on rotating shaft 874 is provided, with the left side of member 872 being alternately conductive at 876 and non-conductive at 878. Coils 880 and 882 are connected to respective brushes 884 and 886 which are positioned to contact member 872 during each rotation of the shaft. Member 872 is connected through brush 890 to power supply 888. Thus, coils 880 and 882 will alternately be energised and de-energised as the respective brushes thereof contact the conductive and non-conductive portions of member 872.

Any of such circuit means, variations thereof, or other circuit means may be used to provide the timed energisation of the control coils in the various embodiments of the present invention.

From the preceding description of the illustrated embodiments, it is evident that the objects of the invention are attained. Although the invention has been described and illustrated in detail, it is to be clearly understood that the same is intended by way of illustration and example only and is not to be taken by way of limitation.

For example, although the magnetic flux control techniques of the present invention have been discussed as applicable mainly to various motive applications, such magnetic flux control techniques are also useful in static applications.

Power Conversion

Referring to **Figs.45A-45C** there is shown the permanent magnet device **900** of **Figs.45A-45C** which has two magnetic flux paths provided by rectangular pole piece **902** which includes upper portion **904** and lower portion **906** each positioned against a respective pole face of permanent magnet **910**. Unlike the device of **Figs.7-9**, fall away armatures are not provided. Instead, fixed armatures in the form of integral pole piece portions **912** and **914** extend from upper portion **904** to lower portion **906** completing the two flux paths in a permanent manner. Control coils **916**, **918** are provided along one flux path and control coils **920**, **922** are provided along the other flux path, such control coils acting as primary windings in device **900**. One coil **924** is positioned around pole piece portion **912** and another coil **926** is positioned around pole piece portion **914**, such coils **924**, **926** acting as secondary windings in device **900**.

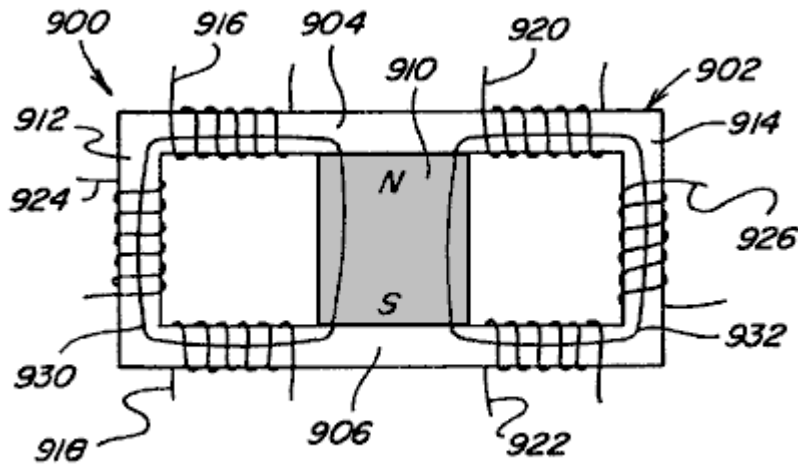

Fig. 45A

In **Fig.45A** no coils are energised and the permanent magnet magnetic flux splits evenly between paths **930** and **932**, coupling with both coil **924** and coil **926**.

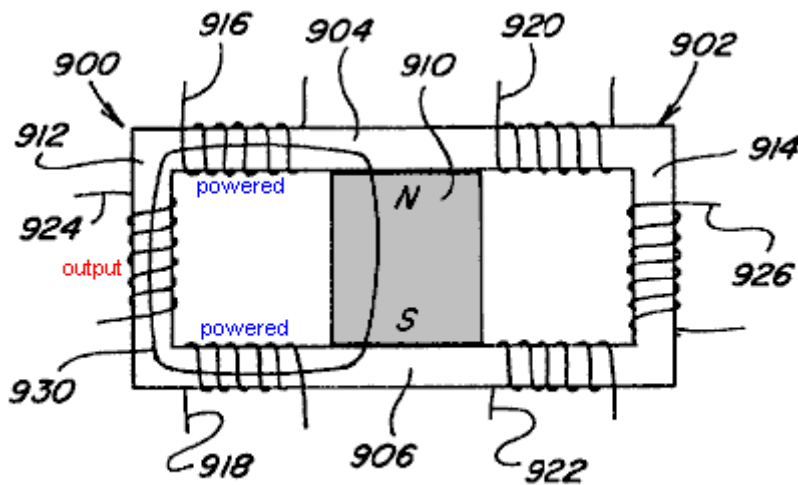

Fig. 45B

In **Fig.45B** coils **916**, **918** are energised in a permanent magnet magnetic flux aiding manner so as to couple with all the magnetic flux of permanent magnet **910**. All magnetic flux flows along path **930** as shown and thus couples with coil **924**.

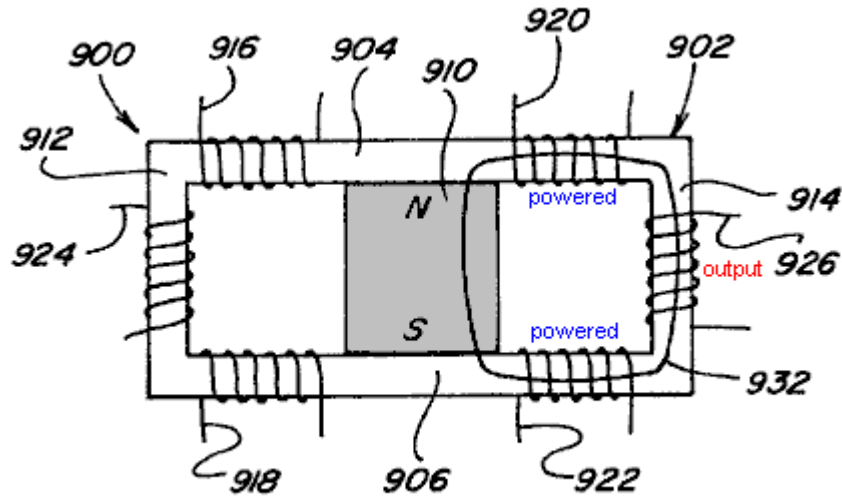

Fig. 45C

In **Fig.45C** coils 920, 922 are energised in a permanent magnet magnetic flux aiding manner such that all magnetic flux traverses path 932 and couples with coil 926. By continuously alternately energising and de-energising coils 916, 918 and 920, 922 in such a manner energy conversion is achieved due to the coupling with coils 924 and 926. The magnetic flux in the integral pole piece portions 912 and 914, and thus the flux coupling with respective coils 924 and 926, varies by a factor of twice the amount of magnetic flux generated by energising coils 916, 918 and 920, 922.

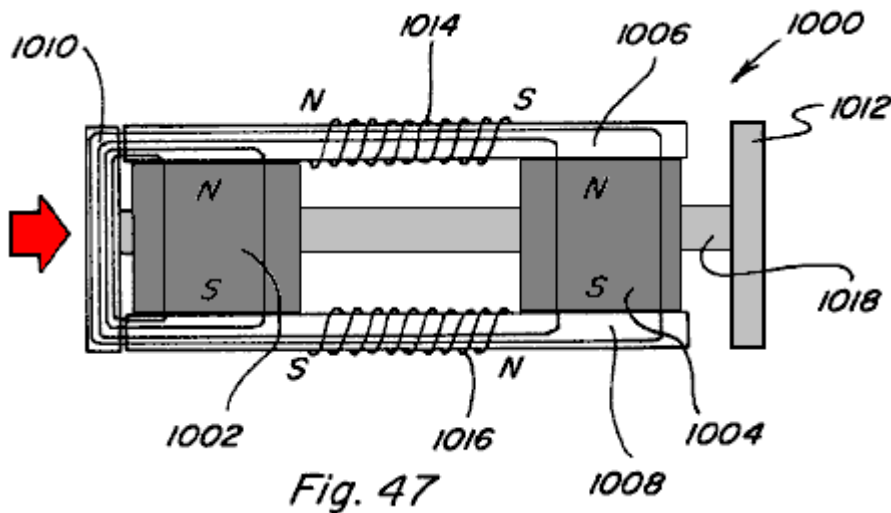

Fig. 47

The construction shown in **Fig.45A** and **Fig.45X** are similar to the construction shown in **Fig.7** and **Fig.47**. The difference in both cases relates to replacing the two flux paths and armatures with one continues flux path. The arrangement in **Fig.7** has one permanent magnet and four coils and the arrangement in **Fig.47** has two permanent magnets and two coils. Although the physical aspects of the two arrangements and the details of the flux control vary, the control method for varying the permanent magnets flux are similar and will be described simultaneously and only differences will be pointed out.

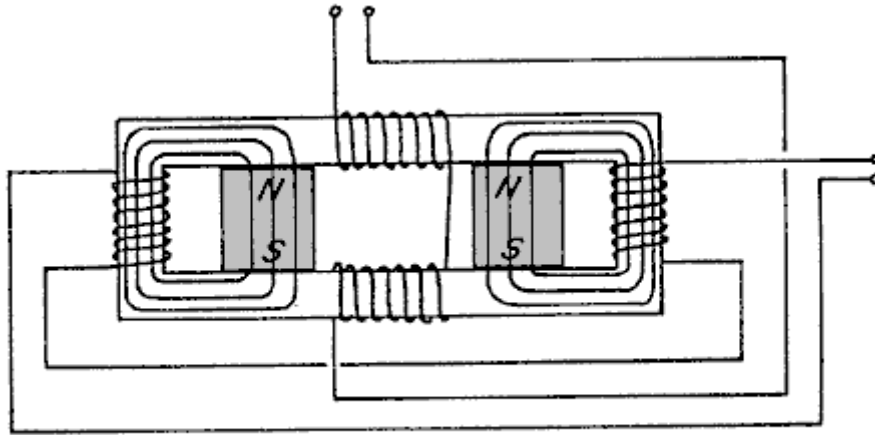

Fig. 45 X

With continuous flux paths the static flux from the permanent magnet or magnets is useless. However, if the static flux of the permanent magnet confined to the flux paths were modified to be time varying it would have utility for electromagnetic induction devices for power conversion like transformers and power inverters. However, the same basic method for controlling the flux of a permanent magnet to provide linear and rotary motion can also be applied to time varying the static flux from the permanent magnet. The construction shown in **Fig.45X** utilises four control coils and a single permanent magnet while the construction shown in **Fig.45A** uses two control coils and two permanent magnets. The flux that would normally be supplied by a primary winding is supplied by the static flux of the permanent magnet or magnets and the control coils convert this static flux into a time varying flux in a novel way. Both arrangements use two secondary coils, the secondary coils are placed in the region of the continuous flux path that would be occupied by an armature or rotor in the linear or rotary arrangements. The regions of the flux paths that perform work are the same in all cases.

In all cases the control coils can either be wired in series or parallel and the secondary coils can be either wound in series or parallel. More than one secondary coil or secondary coils with multiple taps can be placed in the working regions and further multiple flux paths can be utilised with one or more secondary coils placed in each of the working regions. This is made obvious by the disclosures of the linear and rotary devices herein and based on the fact that the working regions of the flux paths are identical.

Fig.45X and **Fig.45A** also show the paths of the static flux of the permanent magnet or magnets when no current is flowing in the control coils. In the arrangement shown in **Fig.45X** the flux from the single permanent magnet divides between the two working areas of the flux path. In the arrangement of **Fig.45A** all of the flux of one of the permanent magnets passes through one of the working regions and all of the flux of the second permanent magnet passes through the other working region. Each of the working regions in both cases are occupied by secondary coils.

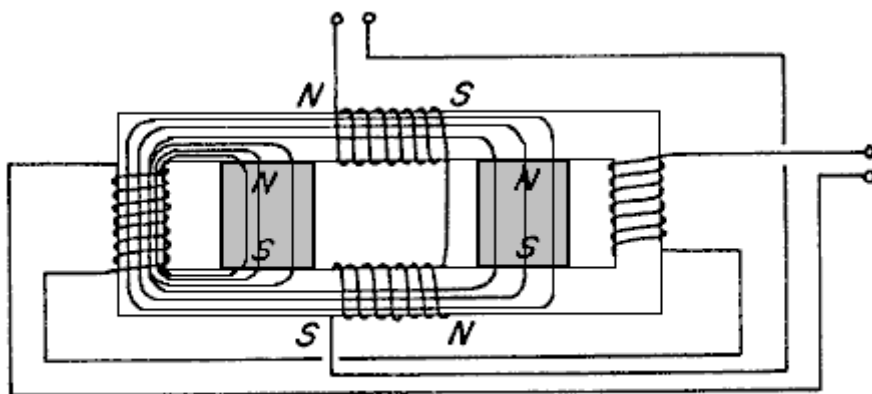

Fig. 45 Y

Fig.45Y and **Fig.45B** show the control coils energised with the polarity shown with respect to the polarity of the permanent magnet or magnets included. In **Fig.45Y** the opposing coil, blocks the passage of flux from the permanent magnet, and the aiding coil couples with the flux of the permanent magnet and therefore all of the flux of the permanent magnet passes through one working region as shown. In **Fig.45B** the opposing side of the coil blocks the passage of flux from the permanent magnet on the opposing side of the coil and the aiding side of the

coil couples with the flux of the other permanent magnet and therefore all of the flux of both the permanent magnets passes through the working region as shown.

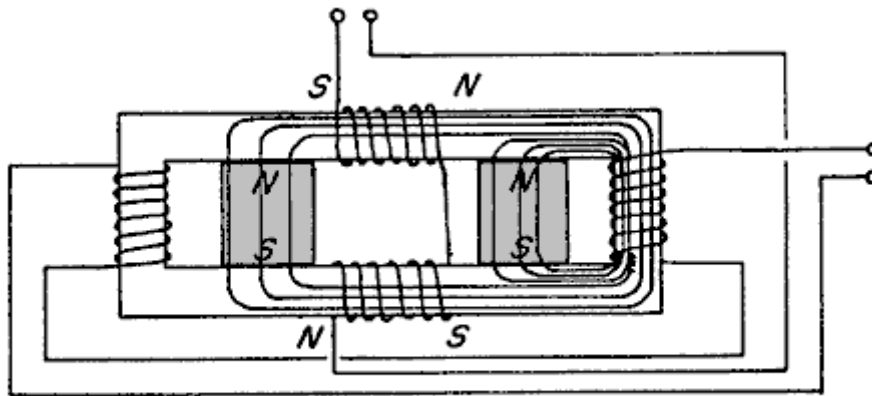

Fig. 45Z

Fig.45Z and **Fig.45C** show the control coils energised with a polarity opposite of that shown in **Fig.45Y** and **Fig.45B**. The same action occurs and results in all of the permanent magnet or magnets path flux passing through the opposite working regions.

By alternating the polarity of the control coils during one cycle, one working region experiences an increasing flux and the opposite region experiences a decreasing flux and during the next cycle the opposite occurs. This results in the induction of a voltage in the secondary coils that is decided by the magnitude of the change in flux in the working region and the time in which this change occurs. The novelty of this discovery is that the primary flux inducing the voltage in the secondary coils is supplied by the permanent magnet or magnets and is far greater than the flux supplied by the control coils.

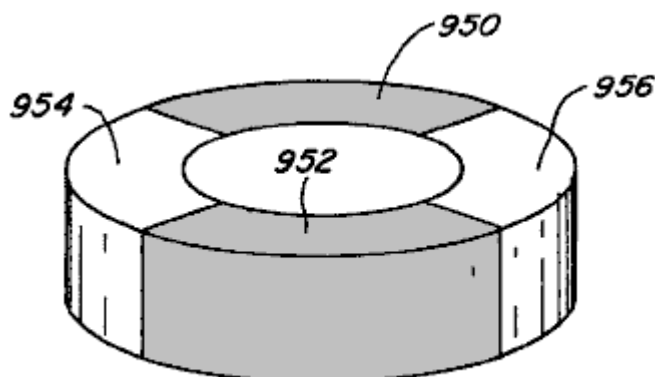

Fig. 46

Further, in the rotary motion devices of **Fig.31** and **Fig.34**, it is not necessary that respective rotor members **702** and **744** be formed of permanent magnets. Each could take the form shown in **Fig.46** where sections **950** and **952** are formed of magnetic material such as soft iron and sections **954** and **956** are formed by a non-magnetic filler material.

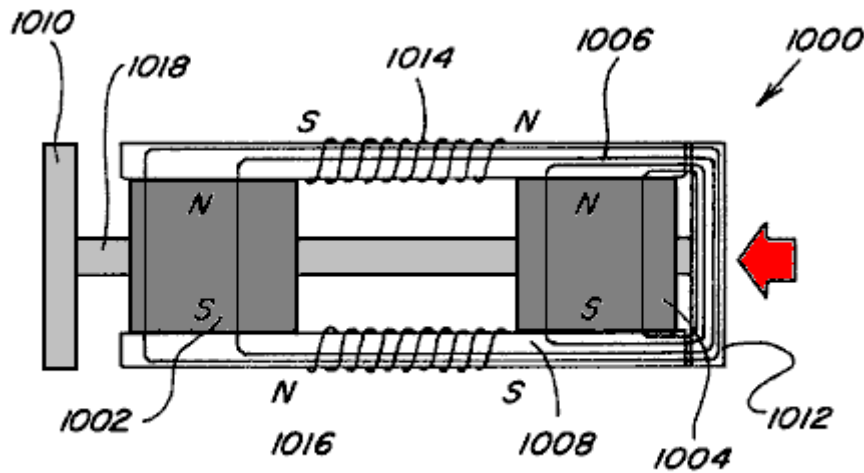

Fig. 48

Fig.47 and **Fig.48** show another embodiment **1000** of the subject device. The embodiment **1000** includes two spaced permanent magnets **1002** and **1004** each of which has its north pole adjacent to the upper surface and its south pole adjacent to the lower surface. A magnetisable bridging member **1006** extends across and makes contact with the north magnetic poles of the magnets **1002** and **1004** and another magnetisable bridging member **1008** makes contact with the south magnetic poles of the two permanent magnets **1002** and **1004**.

The members **1006** and **1008** extend slightly beyond the opposite sides of the respective permanent magnets **1002** and **1004** and a pair of spaced armature members **1010** and **1012** are positioned to move into and out of engagement with the ends of the members **1006** and **1008**. Coils **1014** and **1016** are mounted respectively on the members **1006** and **1008** in the space between the permanent magnets **1002** and **1004**, and the armatures **1010** and **1012** are shown connected together by a rod **1018** which enables them to move backwards and forwards into engagement with the respective members **1006** and **1008** when different voltages are applied to the respective coils **1014** and **1016**.

In **Fig.47**, the coils **1014** and **1016** are energised as shown with the coil **1014** having its north magnetic end to the left and its south magnetic end to the right and the opposite is true of the coil **1016**. In **Fig.48**, the voltage applied to the respective coils **1014** and **1016** is reversed so that the polarity of the left end of coil **1014** is south and the polarity of the opposite end of the same coil **1014** is a north magnetic pole. The reverse is true of the coil **1016**. In **Fig.47** and **Fig.48** it should be noted that the relationship of aiding and opposing is indicated on the figures to indicate the relationship when the coils are energised. For example, in **Fig.47** when the coils are energised as shown the relationship is opposing for the permanent magnet **1002** and is aiding with respect to the permanent magnet **1004**. The reverse is true when the voltage on the coils is reversed as shown in **Fig.48**. The movement of the armature is therefore controlled by the proper timing of the voltage on these coils. The same principles can be applied to produce rotating movement as shown in **Fig.42**.

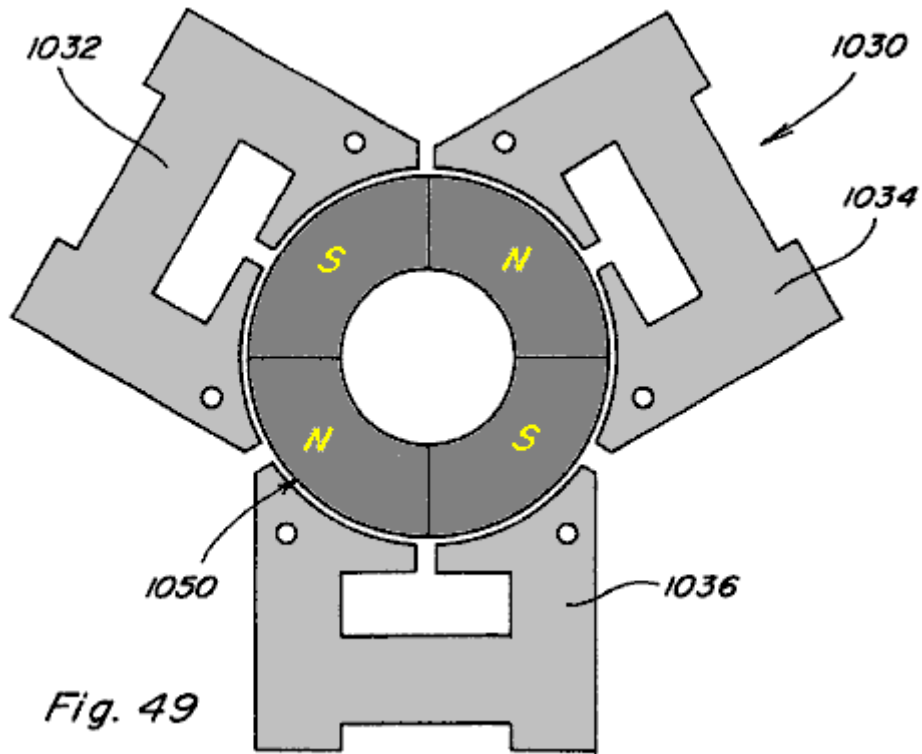
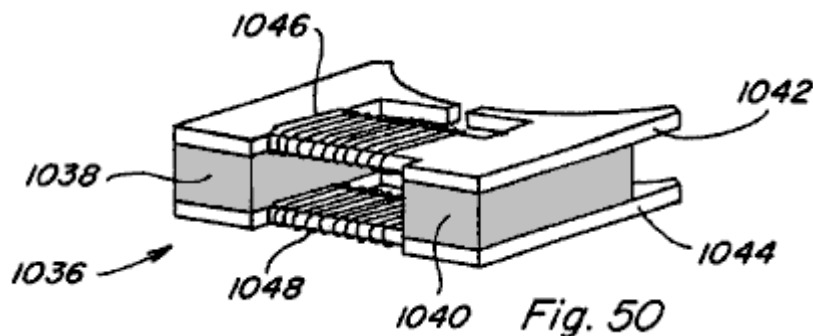

Fig.49 shows another embodiment **1030** of the subject invention using principles similar to those described in connection with **Fig.47** and **Fig.48**. The embodiment **1030** includes a plurality, three being shown, of stationary members **1032**, **1034** and **1036**.



The details of these members are better shown in **Fig.50** which shows the details of the member **1036**. This member includes a pair of permanent magnets **1038** and **1040**, each of which has magnetisable members mounted adjacent to it's opposite sides, as in the previous construction. The members **1042** and **1044** also have coils **1046** and **1048**, respectively, and the coils are energised as described in connection with **Fig.47** and **Fig.48** to produce aiding and opposing magnetism. The construction shown in **Fig.49** may have three stator portions as shown or it may have more stator portions as desired. The rotor **1050** is positioned in the space between the members **1032**, **1034** and **1036** and includes a permanent magnet portion part of which has its north magnetic pole on the surface as shown and the other parts has its south magnetic pole in the same surface as shown. The permanent magnets **1038** and **1040** on the stators interact with the permanent magnets on the rotor to produce the rotating motion and is controlled by the energising of the coils.

Other applications and advantages of the devices and methods of the present invention exist and various modifications are possible, and therefore the present invention is not intended to be limited to the specific examples disclosed herein. Accordingly, the spirit and scope of the invention are to be limited only by the terms of the appended claims.

CLAIMS

1. A permanent magnet device, comprising a permanent magnet having north and south pole faces, a first pole piece, a second pole piece, a first control coil, a second control coil, and circuit means, the first pole piece positioned adjacent the north pole face of the permanent magnet and including a first path portion, a second path portion and a third portion, the first path portion extending beyond a perimeter of the north pole face in

one direction and the second path portion extending beyond the perimeter of the north pole face in another direction to define first and second flux paths for magnetic flux emanating from the north pole face of the permanent magnet, the first path portion of the first pole piece connected to the second path portion of the first pole piece by the third portion which extends across the north pole face of the permanent magnet, the second pole piece positioned adjacent the south pole face and including a first path portion and a second path portion, the first path portion extending beyond a perimeter of the south pole face and substantially aligned with the first path portion of the first pole piece, the second path portion extending beyond the perimeter of the south pole face and substantially aligned with the second path portion of the first pole piece, the first control coil positioned around the first path portion of the first pole piece, the second control coil positioned around the second path portion of the first pole piece, the circuit means connected to each of the first control coil and the second control coil to alternately energise the first coil and the second coil in a timed sequential manner.

2. The permanent magnet device as set forth in claim 1, wherein the first control coil and the second control coil are alternately energised in a permanent magnet magnetic flux aiding manner.
3. The permanent magnet device as set forth in claim 1, wherein the first control coil and the second control coil are alternately energised in a permanent magnet magnetic flux opposing manner.
4. The permanent magnet device as set forth in claim 1, further comprising a rotor member mounted on a shaft for rotation therewith, the rotor member sized, shaped, and positioned to extend substantially from the first path portion of the first pole piece to the first path portion of the second pole piece during at least some part of its rotation.
5. The permanent magnet device as set forth in claim 4, wherein the rotor member is formed by at least one permanent magnet.
6. The permanent magnet device as set forth in claim 1, wherein the second path portion of the first pole piece and the second path portion of the second pole piece are positioned alongside the first path portion of the first pole piece and the first path portion of the first pole piece.
7. The permanent magnet device as set forth in claim 1, further comprising a first bypass extending from the first path portion of the first pole piece to the first path portion of the second pole piece, one end of the first bypass positioned adjacent the first path portion of the first pole piece and between the permanent magnet and the first control coil.
8. The permanent magnet device as set forth in claim 6, further comprising a second bypass extending from the second path portion of the first pole piece to the second path portion of the second pole piece, one end of the second bypass positioned adjacent the second path portion of the first pole piece and between the permanent magnet and the second control coil.
9. The permanent magnet device as set forth in claim 1, further comprising a plurality of armatures arranged to define a path of movement, wherein the second path portion of the first pole piece and the second path portion of the second pole piece are positioned alongside the first path portion of the first pole piece and the first path portion of the second pole piece, and wherein all of such pole piece path portions include an end face positioned adjacent the path of movement defined by the plurality of armatures.
10. The permanent magnet device as set forth in claim 1, wherein the first control coil and the second control coil are simultaneously energised one in a permanent magnet magnetic flux aiding manner and one in a permanent magnet magnetic flux opposing manner.
11. The permanent magnet device as set forth in claim 1, further comprising two shaft connected armatures which can be positioned adjacent the ends of the first and second pole pieces, wherein each of the armatures is formed by a permanent magnet.
12. The permanent magnet device of claim 1 further comprising a first fixed armature extending between the first path portion of the first pole piece to the first path portion of the second pole piece and a second fixed armature extending between the second path portion on the first pole piece to the second path portion of the second pole piece.
13. The permanent magnet device of claim 12 where a first secondary coil is wrapped around the first fixed armature and a second secondary coil is wrapped around the second fixed armature.
14. The permanent magnet device of claim 13 including circuit means connected to the control coils to control the energising thereof to produce a varying flux in the armatures and to induce voltage in the secondary coils.

- 15.** The permanent magnet device of claim 1 wherein there are at least two permanent magnets each having north and south pole faces, the first pole piece being positioned extending between the north pole faces of the permanent magnets and the second pole piece positioned extending between adjacent south pole faces of the permanent magnets.
- 16.** A method for controlling the path of magnetic flux from a permanent magnet, the method comprising the steps of:
- (a) placing a first pole piece adjacent a first pole face of the permanent magnet so as to have at least first and second path portions extending beyond a perimeter of the first pole face;
 - (b) placing a second pole piece adjacent a second pole face of the permanent magnet so as to include at least one portion which substantially aligns with the first and second path portions of the first pole piece;
 - (c) placing a first control coil along and around the first path portion of the first pole piece;
 - (d) placing a second control coil along and around the second path portion of the first pole piece;
 - (e) repeatedly energising the first control coil in a permanent magnet magnetic flux opposing manner so as to prevent magnetic flux of the permanent magnet from traversing the first path portion of the first pole piece; and
 - (f) repeatedly energising the second control coil in a permanent magnet magnetic flux opposing manner so as to prevent magnetic flux of the permanent magnet from traversing the second path portion of the first pole piece.
- 17.** The method as set forth in claim 16 wherein the energisation of steps (e) and (f) take place in a simultaneous manner.
- 18.** A method for controlling the path of magnetic flux from a permanent magnet, the method comprising the steps of:
- (a) placing a first pole piece adjacent a first pole face of the permanent magnet so as to have at least first and second path portions extending beyond a perimeter of the first pole face;
 - (b) placing a second pole piece adjacent a second pole face of the permanent magnet so as to include at least one portion which substantially aligns with the first and second path portions of the first pole piece;
 - (c) placing a first control coil along and around the first path portion of the first pole piece;
 - (d) placing a second control coil along and around the second path portion of the first pole piece; and
 - (e) alternately performing the following steps in a repeated manner:
 - (i) energising the first control coil in a permanent magnet magnetic flux aiding manner so as to couple with substantially all magnetic flux of the permanent magnet such that substantially no magnetic flux of the permanent magnet traverses the second path portion of the first pole piece when the first control coil is so energised; and
 - (ii) energising the second control coil in a permanent magnet magnetic flux opposing manner so as to couple with substantially all magnetic flux of the permanent magnet such that substantially no magnetic flux of the permanent magnet traverses the first path portion of the first pole piece when the second control coil is so energised.
- 19.** A method for controlling the path of magnetic flux from a permanent magnet the method comprising the steps of:
- (a) placing a first pole piece adjacent a first pole face of the permanent magnet so as to have at least first and second path portions extending beyond a perimeter of the first pole face;
 - (b) placing a second pole piece adjacent a second pole face of the permanent magnet so as to include at least one portion which substantially aligns with the first and second path portions of the first pole piece;

- (c) placing a first control coil along and around the first path portion of the first pole piece;
- (d) placing a second control coil along and around the second path portion of the first pole piece; and
- (e) alternately performing the following steps in a repeated manner:
 - (i) simultaneously energising the first control coil in a permanent magnet magnetic flux aiding manner and the second control coil in a permanent magnet flux opposing manner; and
 - (ii) simultaneously energising the first control coil in a permanent magnet flux opposing manner and the second control coil in a permanent magnet magnetic flux aiding manner.

20. A rotary motion device, comprising a rotor assembly including a shaft which defines an axis of rotation of the assembly, a rotor pole piece mounted for rotation with the shaft, the rotor pole piece including an outer ring portion having at least two path portions extending inwardly from a periphery of the outer ring portion;

a stator assembly including a permanent magnet having a generally ring-shaped configuration, a first pole face of the permanent magnet positioned adjacent the outer ring portion of the rotor pole piece, the stator assembly further comprising a stator pole piece including an outer ring portion positioned adjacent a second pole face of the permanent magnet and having a plurality of path portions extending inwardly from the periphery, each path portion further including a respective portion which extends toward a plane defined by the first pole face of the permanent magnet and capable of being aligned with each of the rotor pole piece path portions at certain rotational positions of the rotor pole piece, each path portion including a control coil positioned along it;

and circuit means connected to each of the coils and including a source of electrical energy and switch means for energising respective ones of the control coils in a predetermined timed sequence based upon rotation of the rotor assembly.

21. A rotary motion device, comprising:

a rotor assembly including a shaft which defines an axis of rotation of the assembly, a pair of spaced elongated rotor members mounted on the shaft at spaced locations thereon and angularly oriented with respect to each other, each of the elongated rotor members formed of a magnetic material;

a stator assembly including a permanent magnet having opposed first and second pole faces, a first pole piece positioned adjacent the first pole face and a second pole piece positioned adjacent the second pole face, each pole piece including a respective first path portion extending beyond a perimeter of its adjacent pole face and having an curved shaped end portion, the first path portion of the first pole piece aligned with the first path portion of the second pole piece, each pole piece further including a respective second path portion extending beyond the perimeter of its adjacent pole face in a direction opposite to that of the first path portions and having an curved shaped end portion, the second path portion of the first pole piece aligned with the second path portion of the second pole piece, at least one of the first path portions of the first pole piece and the first path portion of the second pole piece including a control coil mounted on at least one of the pole pieces, at least one of the second path portions of the first pole piece and the second path portion of the second pole piece including a control coil mounted on at least one of the pole pieces,

wherein the rotor assembly extends from end to end of the stator assembly such that the elongate members are aligned with the curved shaped end portions of the path portions of the pole pieces;

and circuit means connected to each of the coils and including a source of electrical energy and switch means for energising respective ones of the control coils in a predetermined timed sequence based upon rotation of the rotor assembly.

22. A rotary motion device comprising:

a rotor assembly including a shaft which defines an axis of rotation of the assembly, a ring-shaped rotor member mounted for rotation with the shaft, the ring-shaped rotor member including a plurality of distinct circumferential regions;

a stator assembly including a first permanent magnet, a first pole piece positioned against a first pole face and a second pole piece positioned against a second pole face, the first pole piece including at least a first path portion extending beyond a perimeter of the first pole face, the second pole piece including at least a first path portion extending beyond a perimeter of the second pole face, the first path portion of the first pole piece aligned with the first path portion of the second pole piece, at least a portion of the ring-shaped rotor member

positioned between the first path portion of the first pole piece and the first path portion of the second pole piece, at least one of the first path portions of the first pole piece and the first path portion of the second pole piece including a first control coil positioned at a point intermediate the first permanent magnet and the ring-shaped rotor member;

and circuit means connected to the first control coil and including a source of electrical energy and switch means for energising the first control coil in a predetermined timed manner based upon rotation of the rotor assembly.

23. The rotary motion device as set forth in claim 22, wherein the ring-shaped rotor member is formed by a permanent magnet having distinct circumferential regions of opposite polarity.

24. The rotary motion device as set forth in claim 23, wherein the first pole piece includes a second path portion spaced from and extending adjacent to the first path portion, the second pole piece including a second path portion spaced from and extending adjacent to the first path portion such that the second path portion of the first pole piece is aligned with the second path portion of the second pole piece, at least a portion of the ring-shaped permanent magnet rotor member positioned between the second path portion of the first pole piece and the second path portion of the second pole piece, at least one of the second path portions of the first pole piece and the second path portion of the second pole piece having a second control coil mounted on at least one of the pole pieces at a point intermediate the first permanent magnet and the ring-shaped permanent magnet rotor member, the second control coil connected to the circuit means so as to be energised in a predetermined timed manner based upon rotation of the rotor assembly.

25. The rotary motion device as set forth in claim 22, wherein the stator assembly further comprises a second permanent magnet, a third pole piece positioned adjacent a first pole face of the second permanent magnet and a fourth pole piece positioned adjacent a second pole face of the second permanent magnet, the third pole piece including at least a first path portion extending beyond a perimeter of the second permanent magnet first pole face, the fourth pole piece including at least a first path portion extending beyond a perimeter of the second permanent magnet second pole face, the first path portion of the third pole face aligned with the first path portion of the fourth pole piece, at least a portion of the ring-shaped permanent magnet rotor member positioned between the first path portion of the third pole piece and the first path portion of the fourth pole piece, at least one of the first path portions of the third pole piece and the first path portion of the fourth pole piece including a third control coil mounted on at least one of the pole pieces at a point intermediate the second permanent magnet and the ring-shaped permanent magnet rotor member, the third pole piece including a second path portion spaced from and extending adjacent to the first path portion the fourth pole piece including a second path portion spaced from and extending adjacent to the first path portion thereof such that the second path portion of the third pole piece is aligned with the second path portion of the fourth pole piece, at least a portion of the ring-shaped permanent magnet rotor member positioned between the second path portion of the third pole piece and the second path portion of the fourth pole piece, at least one of the second path portions of the third pole piece and the second path portion of the fourth pole piece including a fourth control coil mounted on at least one of the pole pieces at a point intermediate the second permanent magnet and the ring-shaped permanent magnet rotor member, wherein each of the third and fourth control coils are connected to the circuit means so as to be energised in a predetermined timed manner based upon rotation of the rotor assembly.

26. A device for producing rotary motion comprising:

a rotor assembly including a shaft which defines an axis of rotation for the assembly, a ring-shaped rotor member mounted for rotation with the shaft, the ring-shaped rotor member having a plurality of distinct circumferentially positioned regions extending around the axis, a stator assembly including a first permanent magnet, a first pole piece positioned against the first pole face of the first pole piece and a second pole piece positioned against a second pole face of the first pole piece, the first pole piece including at least a first path portion extending beyond a perimeter of the first pole face, the second pole piece including at least a first path portion extending beyond the perimeter of the second pole face, the first path portion of the first pole piece aligned with the first path portion of the second pole piece, at least a portion of the ring-shaped rotor member positioned between the first path portion of the first pole piece and the first path portion of the second pole piece, at least one of the first path portions of the first pole piece and the first path portion of the second pole piece including a first control coil mounted on at least one of the pole pieces at a point intermediate the first permanent magnet and the ring-shaped rotor member; and circuit means connected to the first control coil and including a source of electrical energy and switch means for energising the first control coil in a predetermined timed manner based upon position of the rotor assembly during rotation of the rotor assembly.

27. The device for producing rotary motion of claim 26 wherein the circuit means includes means for timing the energising of the first control coil includes means for adjusting the timing thereof.

- 28.** The device for producing rotor motion of claim 26 including means to vary the flux generated in the first and second pole pieces.
- 29.** A device for handling the flux between two separate permanent magnets each of which has a north magnetic pole adjacent one side face and the south magnetic pole adjacent to the opposite side face, the north and south side pole faces respectively of both magnets being substantially in alignment, a first member in surface-to-surface contact with the north magnetic faces of the spaced permanent magnets, a second member in surface-to-surface contact with the south magnetic faces of the spaced permanent magnets, first and second armatures each positioned adjacent opposite ends of the first and second permanent magnets and adjacent to opposite ends of the spaced members, a coil mounted on each of the members in the space between the adjacent permanent magnets, and means for applying voltages of predetermined polarities across the respective coils to change the magnetic coupling between the permanent magnets and between the armatures.
- 30.** A device for producing rotational movement comprising:
- a rotor having a shaft rotatable about the axis thereof, a member constructed of permanent magnets mounted on the shaft, said member having circumferential portions some of which have a north magnetic pole and others a south magnetic pole adjacent to the same side thereof, the opposite surface of the permanent magnet member having north magnetic poles opposite the south magnetic poles and south magnetic poles opposite the north magnetic poles, a stator having a plurality of circumferentially spaced portions each of which includes at least one permanent magnet and a pair of members mounted adjacent opposite sides of the permanent magnets, the members being positioned adjacent to the periphery of the rotor permanent magnet member and means on the member adjacent each opposite side of the stator permanent magnet for mounting a coil, and means for energising the coil on each stator portion in sequence to produce magnetic coupling force between the stator and the rotor in a direction to produce rotating motion of the rotor.
- 31.** A device including a rotating member and a stationary member, each having a permanent magnet portion positioned to produce magnetic coupling force between them in predetermined positions thereof, the rotor including a shaft rotatable about its axis and the permanent magnet extending around the shaft and formed by a plurality of adjacent portions of permanent magnet material whereby adjacent portions have their north and south magnetic pole faces on opposite sides of the rotor permanent magnet, a plurality of stator members each stator member having at least one permanent magnet having a north magnetic pole adjacent one side and a south magnetic pole adjacent to the opposite side, a pair of members positioned adjacent respective opposite sides of the stator permanent magnet in position to extend to adjacent the rotor permanent magnet whereby a flux path is formed between the members and the stator and rotor permanent magnets, a coil mounted on each member of the stator and means for applying a voltage of predetermined polarity to each of said coils to control the flux through a path between the permanent magnets and to control the coupling force between the permanent magnets on the stator and the permanent magnets on the rotor.
- 32.** A motion producing device comprising at least one permanent magnet having a north pole opposite and spaced from a south pole, a pair of spaced substantially parallel members adjacent respectively the north and south poles of the at least one permanent magnet and extending outwardly to substantially aligned opposite edges, a flux supporting member positioned adjacent the respective opposite edges of each pair of parallel members, a coil on selected ones of the parallel members, and a source of electrical energy connected to each of the coils for energising the coils to change the flux in the parallel members and in the flux supporting members.
- 33.** The motion producing device of claim 32 wherein there are at least two spaced permanent magnets extending between the parallel members.
- 34.** The motion producing device of claim 32 wherein one of said pair of parallel members is subdivided into a plurality of sidewardly extending portions extending to one of said opposite side edges, at least one of said coils being positioned on at least one of said sidewardly extending portions.
- 35.** The motion producing device of claim 34 wherein there are coils on a plurality of respective ones of the sidewardly extending portions.
- 36.** The motion producing device of claim 32 wherein the permanent magnet and the parallel members are annular in shape.
- 37.** The motion producing device of claim 32 including a by-pass member extending between the pair of spaced substantial parallel members adjacent one side of the permanent magnet.

- 38.** A permanent magnet device comprising at least two permanent magnets each having north and south pole faces, a first pole piece, a second pole piece, a first control coil, a second control coil and circuit means, the first pole piece positioned adjacent the north pole faces of the at least two permanent magnets and including a first path portion, a second path portion and a third path portion, the first path portion extending beyond the perimeter of the north pole faces and the second path portion extending beyond the perimeter of the north pole faces to define first and second flux paths for magnetic flux emitting from the north pole faces of the at least two permanent magnets, the first path portion of the first pole piece connected to the second path portion of the first pole piece by a third portion which extends across the north pole face of the at least two permanent magnets, the second pole piece positioned adjacent to the south pole faces of the at least two permanent magnets and including a first path portion and a second path portion, the first path portion extending beyond a perimeter of the south pole faces and substantially aligned with the first path portion of the first pole piece, the second path portion extending beyond the perimeter of the south pole faces and substantially aligned with the second path portion of the first pole piece, the first control coil positioned around the first path portion of the first pole piece, the second control coil positioned around the second path portion of the first pole piece, and the circuit means connected to each of the first control coil and the second control coil to alternately energise the first coil and the second coil in a timed sequential manner.
- 39.** The permanent magnet device of claim 38 further comprising a first fixed armature extending between the first path portion of the first pole piece to the first path portion of the second pole piece and a second fixed armature extending between the second path portion of the first pole piece to the second path portion of the second pole piece.
- 40.** The permanent magnet device of claim 39 where a first secondary coil is wrapped around the first fixed armature and a second secondary coil is wrapped around the second fixed armature.
- 41.** The permanent magnet device of claim 40 including circuit means connected to the control coils to control the energising thereof to produce a varying flux in the armatures and to induce voltage in the secondary coils.
- 42.** The permanent magnet device of claim 38 wherein there are at least two permanent magnets each having north and south pole faces, the first pole piece being positioned extending between the north pole faces of the permanent magnets and the second pole piece positioned extending between the south pole faces of the permanent magnets.

Inventors: Stephen Patrick, Thomas Bearden, James Hayes, Kenneth Moore and James Kenny

MOTIONLESS ELECTROMAGNETIC GENERATOR

Please note that this is a re-worded excerpt from this patent. It describes an electrical device which both powers itself and supplies current to additional external equipment.

ABSTRACT

An electromagnetic generator without moving parts includes a permanent magnet and a magnetic core including first and second magnetic paths. A first input coil and a first output coil extend around portions of the first magnetic path, while a second input coil and a second output coil extend around portions of the second magnetic path. The input coils are alternatively pulsed to provide induced current pulses in the output coils. Driving electrical current through each of the input coils reduces a level of flux from the permanent magnet within the magnet path around which the input coil extends. In an alternative embodiment of an electromagnetic generator, the magnetic core includes annular spaced-apart plates, with posts and permanent magnets extending in an alternating fashion between the plates. An output coil extends around each of these posts. Input coils extending around portions of the plates are pulsed to cause the induction of current within the output coils.

DESCRIPTION

1. Field of the Invention: This invention relates to a magnetic generator without moving parts, used to produce electrical power, and more particularly, to such a device capable of powering itself.

2. Description of the Related Art: The patent literature describes a number of magnetic generators, each of which includes a permanent magnet, two magnetic paths external to the permanent magnet, each of which extends between the opposite poles of the permanent magnet, switching means for causing magnetic flux to flow alternately along each of the two magnetic paths, and one or more output coils in which current is induced to flow by means of changes in the magnetic field within the device. These devices operate in accordance with an extension of Faraday's Law, indicating that an electrical current is induced within a conductor within a changing magnetic field, even if the source of the magnetic field is stationary.

A method for switching magnetic flux to flow predominantly along either of two magnetic paths between opposite poles of a permanent magnet is described as a "flux transfer" principle by R. J. Radus in Engineer's Digest, Jul. 23, 1963. This principle is used to exert a powerful magnetic force at one end of both the north and south poles and a very low force at the other end, without being used in the construction of a magnetic generator. This effect can be caused mechanically, by keeper movement, or electrically, by driving electrical current through one or more control windings extending around elongated versions of the pole pieces **14**. Several devices using this effect are described in U.S. Patent Nos. 3,165,723, 3,228,013, and 3,316,514.

Another step toward the development of a magnetic generator is described in U.S. Patent No. 3,368,141, as a device including a permanent magnet in combination with a transformer having first and second windings about a core, with two paths for magnetic flux leading from each pole of the permanent magnet to either end of the core, so that, when an alternating current induces magnetic flux direction changes in the core, the magnetic flux from the permanent magnet is automatically directed through the path which corresponds with the direction taken by the magnetic flux through the core due to the current. In this way, the magnetic flux is intensified. This device can be used to improve the power factor of a typically inductively loaded alternating current circuit.

Other patents describe magnetic generators in which electrical current from one or more output coils is described as being made available to drive a load, in the more conventional manner of a generator. For example, U.S. Patent No. 4,006,401 describes an electromagnetic generator including a permanent magnet and a core member, in which the magnetic flux flowing from the magnet in the core member is rapidly alternated by switching to generate an alternating current in a winding on the core member. The device includes a permanent magnet and two separate magnetic flux circuit paths between the north and south poles of the magnet. Each of the circuit paths includes two switching means for alternately opening and closing the

circuit paths, generating an alternating current in a winding on the core member. Each of the switching means includes a switching magnetic circuit intersecting the circuit path, with the switching magnetic circuit having a coil through which current is driven to induce magnetic flux to saturate the circuit path extending to the permanent magnet. Power to drive these coils is derived directly from the output of a continuously applied alternating current source. What is needed is an electromagnetic generator not requiring the application of such a current source.

U.S. Patent No. 4,077,001 describes a magnetic generator, or dc/dc converter, comprising a permanent magnet having spaced-apart poles and a permanent magnetic field extending between the poles of the magnet. A variable-reluctance core is disposed in the field in fixed relation to the magnet and the reluctance of the core is varied to cause the pattern of lines of force of the magnetic field to shift. An output conductor is disposed in the field in fixed relation to the magnet and is positioned to be cut by the shifting lines of permanent magnetic force so that a voltage is induced in the conductor. The magnetic flux is switched between alternate paths by means of switching coils extending around portions of the core, with the flow of current being alternated between these switching coils by means of a pair of transistors driven by the outputs of a flip-flop. The input to the flip flop is driven by an adjustable frequency oscillator. Power for this drive circuit is supplied through an additional, separate power source. What is needed is a magnetic generator not requiring the application of such a power source.

U.S. Patent No. 4,904,926 describes another magnetic generator using the motion of a magnetic field. The device includes an electrical winding defining a magnetically conductive zone having bases at each end, the winding including elements for the removing of an induced current therefrom. The generator further includes two pole magnets, each having a first and a second pole, each first pole in magnetic communication with one base of the magnetically conductive zone. The generator further includes a third pole magnet, the third pole magnet oriented intermediately of the first poles of the two pole electromagnets, the third pole magnet having a magnetic axis substantially transverse to an axis of the magnetically conductive zone, the third magnet having a pole nearest to the conductive zone and in magnetic attractive relationship to the first poles of the two pole electromagnets, in which the first poles thereof are like poles. Also included in the generator are elements, in the form of windings, for cyclically reversing the magnetic polarities of the electromagnets. These reversing means, through a cyclical change in the magnetic polarities of the electromagnets, cause the magnetic flux lines associated with the magnetic attractive relationship between the first poles of the electromagnets and the nearest pole of the third magnet to correspondingly reverse, causing a wiping effect across the magnetically conductive zone, as lines of magnetic flux swing between respective first poles of the two electromagnets, thereby inducing electron movement within the output windings and thus generating a flow of current within the output windings.

U.S. Patent No. 5,221,892 describes a magnetic generator in the form of a direct current flux compression transformer including a magnetic envelope having poles defining a magnetic axis and characterised by a pattern of magnetic flux lines in polar symmetry about the axis. The magnetic flux lines are spatially displaced relative to the magnetic envelope using control elements which are mechanically stationary relative to the core. Further provided are inductive elements which are also mechanically stationary relative to the magnetic envelope. Spatial displacement of the flux relative to the inductive elements causes a flow of electrical current. Further provided are magnetic flux valves which provide for the varying of the magnetic reluctance to create a time domain pattern of respectively enhanced and decreased magnetic reluctance across the magnetic valves, and, thereby, across the inductive elements.

Other patents describe devices using superconductive elements to cause movement of the magnetic flux. These devices operate in accordance with the Meissner effect, which describes the expulsion of magnetic flux from the interior of a superconducting structure as the structure undergoes the transition to a superconducting phase. For example, U.S. Patent No. 5,011,821 describes an electric power generating device including a bundle of conductors which are placed in a magnetic field generated by north and south pole pieces of a permanent magnet. The magnetic field is shifted back and forth through the bundle of conductors by a pair of thin films of superconductive material. One of the thin films is placed in the superconducting state while the other thin film is in a non-superconducting state. As the states are cyclically reversed between the two films, the magnetic field is deflected back and forth through the bundle of conductors.

U.S. Patent No. 5,327,015 describes an apparatus for producing an electrical impulse comprising a tube made of superconducting material, a source of magnetic flux mounted about one end of the tube, a means, such as a coil, for intercepting the flux mounted along the tube, and a means for changing the temperature of the superconductor mounted about the tube. As the tube is progressively made superconducting, the magnetic field is trapped within the tube, creating an electrical impulse in the means for intercepting. A reversal of the superconducting state produces a second pulse.

None of the patented devices described above use a portion of the electrical power generated within the device to power the reversing means used to change the path of magnetic flux. Thus, like conventional rotary generators, these devices require a steady input of power, which may be in the form of electrical power

driving the reversing means of one of these magnetic generators or the torque driving the rotor of a conventional rotary generator. Yet, the essential function of the magnetic portion of an electrical generator is simply to switch magnetic fields in accordance with precise timing. In most conventional applications of magnetic generators, the voltage is switched across coils, creating magnetic fields in the coils which are used to override the fields of permanent magnets, so that a substantial amount of power must be furnished to the generator to power the switching means, reducing the efficiency of the generator.

Recent advances in magnetic material, which have particularly been described by Robert C. O'Handley in *Modern Magnetic Materials, Principles and Applications*, John Wiley & Sons, New York, pp. 456-468, provide nanocrystalline magnetic alloys, which are particularly well suited for rapid switching of magnetic flux. These alloys are primarily composed of crystalline grains, or crystallites, each of which has at least one dimension of a few nanometres. Nanocrystalline materials may be made by heat-treating amorphous alloys which form precursors for the nanocrystalline materials, to which insoluble elements, such as copper, are added to promote massive nucleation, and to which stable, refractory alloying materials, such as niobium or tantalum carbide are added to inhibit grain growth. Most of the volume of nanocrystalline alloys is composed of randomly distributed crystallites having dimensions of about 2-40 nm. These crystallites are nucleated and grown from an amorphous phase, with insoluble elements being rejected during the process of crystallite growth. In magnetic terms, each crystallite is a single-domain particle. The remaining volume of nanocrystalline alloys is made up of an amorphous phase in the form of grain boundaries having a thickness of about 1 nm.

Magnetic materials having particularly useful properties are formed from an amorphous Co-Nb-B (cobalt-niobium-boron) alloy having near-zero magnetostriction and relatively strong magnetisation, as well as good mechanical strength and corrosion resistance. A process of annealing this material can be varied to change the size of crystallites formed in the material, with a resulting strong effect on DC coercivity. The precipitation of nanocrystallites also enhances AC performance of the otherwise amorphous alloys.

Other magnetic materials are formed using iron-rich amorphous and nanocrystalline alloys, which generally show larger magnetisation than the alloys based on cobalt. Such materials are, for example, Fe-B-Si-Nb-Cu (iron-boron-silicon-niobium-copper) alloys. While the permeability of iron-rich amorphous alloys is limited by their relatively large levels of magnetostriction, the formation of a nanocrystalline material from such an amorphous alloy dramatically reduces this level of magnetostriction, favouring easy magnetisation.

Advances have also been made in the development of materials for permanent magnets, particularly in the development of materials including rare earth elements. Such materials include samarium cobalt, SmCo₅, which is used to form a permanent magnet material having the highest resistance to demagnetisation of any known material. Other magnetic materials are made, for example, using combinations of iron, neodymium, and boron.

SUMMARY OF THE INVENTION:

It is a first objective of the present invention, to provide a magnetic generator which eliminates the need for an external power source during operation of the generator.

It is a second objective of the present invention to provide a magnetic generator in which a magnetic flux path is changed without a need to overpower a magnetic field to change its direction.

It is a third objective of the present invention to provide a magnetic generator in which the generation of electricity is accomplished without moving parts.

In the apparatus of the present invention, the path of the magnetic flux from a permanent magnet is switched in a manner not requiring the overpowering of the magnetic fields. Furthermore, a process of self-initiated iterative switching is used to switch the magnetic flux from the permanent magnet between alternate magnetic paths within the apparatus, with the power to operate the iterative switching being provided through a control circuit consisting of components known to use low levels of power. With self-switching, a need for an external power source during operation of the generator is eliminated, with a separate power source, such as a battery, being used only for a very short time during start-up of the generator.

According to a first aspect of the present invention, an electromagnetic generator is provided, including a permanent magnet, a magnetic core, first and second input coils, first and second output coils, and a switching circuit. The permanent magnet has magnetic poles at opposite ends. The magnetic core includes a first magnetic path, around which the first input and output coils extend, and a second magnetic path, around which the second input and output coils extend, between opposite ends of the permanent magnet. The switching circuit drives electrical current alternately through the first and second input coils. The electrical

current driven through the first input coil causes the first input coil to produce a magnetic field opposing a concentration of magnetic flux from the permanent magnet within the first magnetic path. The electrical current driven through the second input coil causes the second input coil to produce a magnetic field opposing a concentration of magnetic flux from the permanent magnet within the second magnetic path.

According to another aspect of the present invention, an electromagnetic generator is provided, including a magnetic core, a plurality of permanent magnets, first and second pluralities of input coils, a plurality of output coils, and a switching circuit. The magnetic core includes a pair of spaced-apart plates, each of which has a central aperture, and first and second pluralities of posts extending between the spaced-apart plates. The permanent magnets each extend between the pair of spaced apart plates. Each permanent magnet has magnetic poles at opposite ends, with the magnetic fields of all the permanent magnets being aligned to extend in a common direction. Each input coil extends around a portion of a plate within the spaced-apart plates, between a post and a permanent magnet. An output coil extends around each post. The switching circuit drives electrical current alternately through the first and second input coils. Electrical current driven through each input coil in the first plurality of input coils causes an increase in magnetic flux within each post within the first plurality of posts from permanent magnets on each side of the post and a decrease in magnetic flux within each post within the second plurality of posts from permanent magnets on each side of the post. Electrical current driven through each input coil in the second plurality of input coils causes a decrease in magnetic flux within each post within the first plurality of posts from permanent magnets on each side of the post and an increase in magnetic flux within each post within the second plurality of posts from permanent magnets on each side of the post.

BRIEF DESCRIPTION OF THE DRAWINGS:

Figure 1 is a partly schematic front elevation of a magnetic generator and associated electrical circuits built in accordance with a first version of the first embodiment of the present invention:

FIG. 1

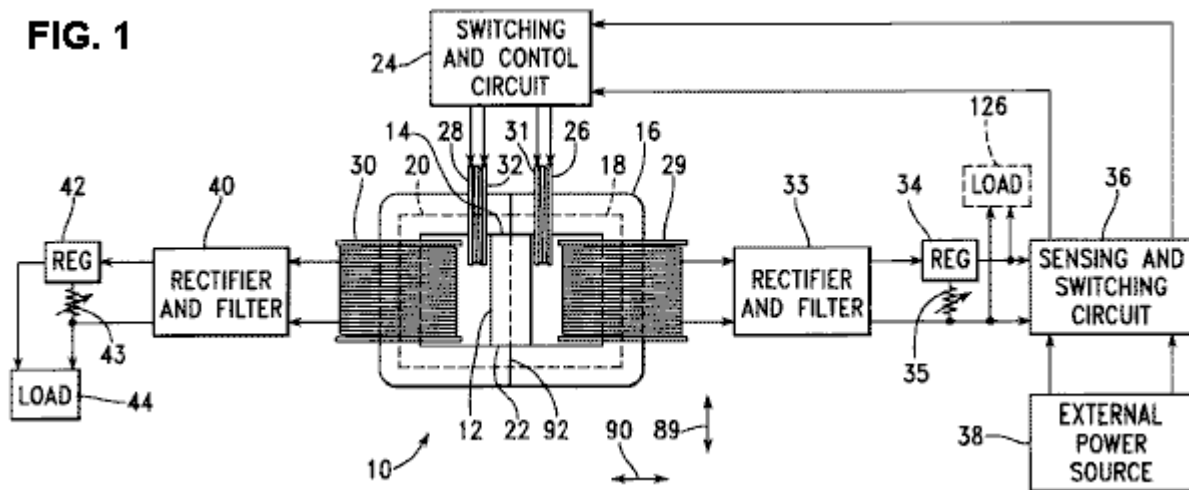

Figure 2 is a schematic view of a first version of a switching and control circuit within the associated electrical circuits of Figure 1:

FIG. 2

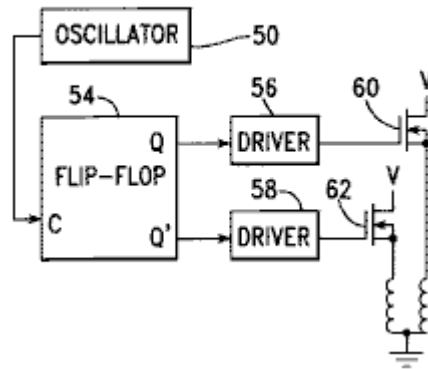

Figure 3 is a graphical view of drive signals produced within the circuit of Figure 2:

FIG. 3

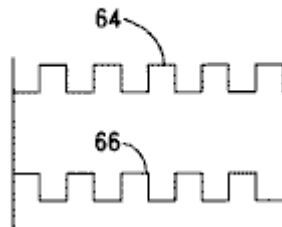

Figure 4 is a schematic view of a second version of a switching and control circuit within the associated electrical circuits of Figure 1:

FIG. 4

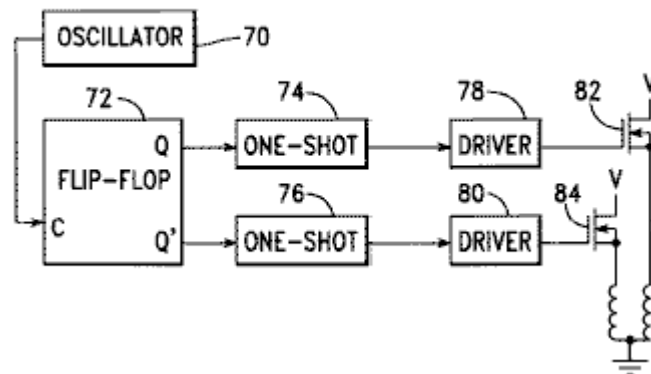

Figure 5 is a graphical view of drive signals produced within the circuit of Figure 3:

FIG. 5

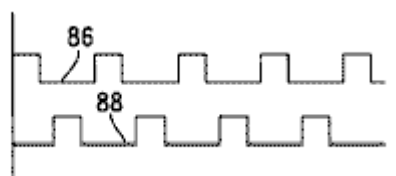

Figure 6A is a graphical view of a first drive signal within the apparatus of Figure 1,

Figure 6B is a graphical view of a second drive signal within the apparatus of Figure 1,
 Figure 6C is a graphical view of an input voltage signal within the apparatus of Figure 1,
 Figure 6D is a graphical view of an input current signal within the apparatus of Figure 1,
 Figure 6E is a graphical view of a first output voltage signal within the apparatus of Figure 1,
 Figure 6F is a graphical view of a second output voltage signal within the apparatus of Figure 1,
 Figure 6G is a graphical view of a first output current signal within the apparatus of Figure 1,
 Figure 6H is a graphical view of a second output current signal within the apparatus of Figure 1:

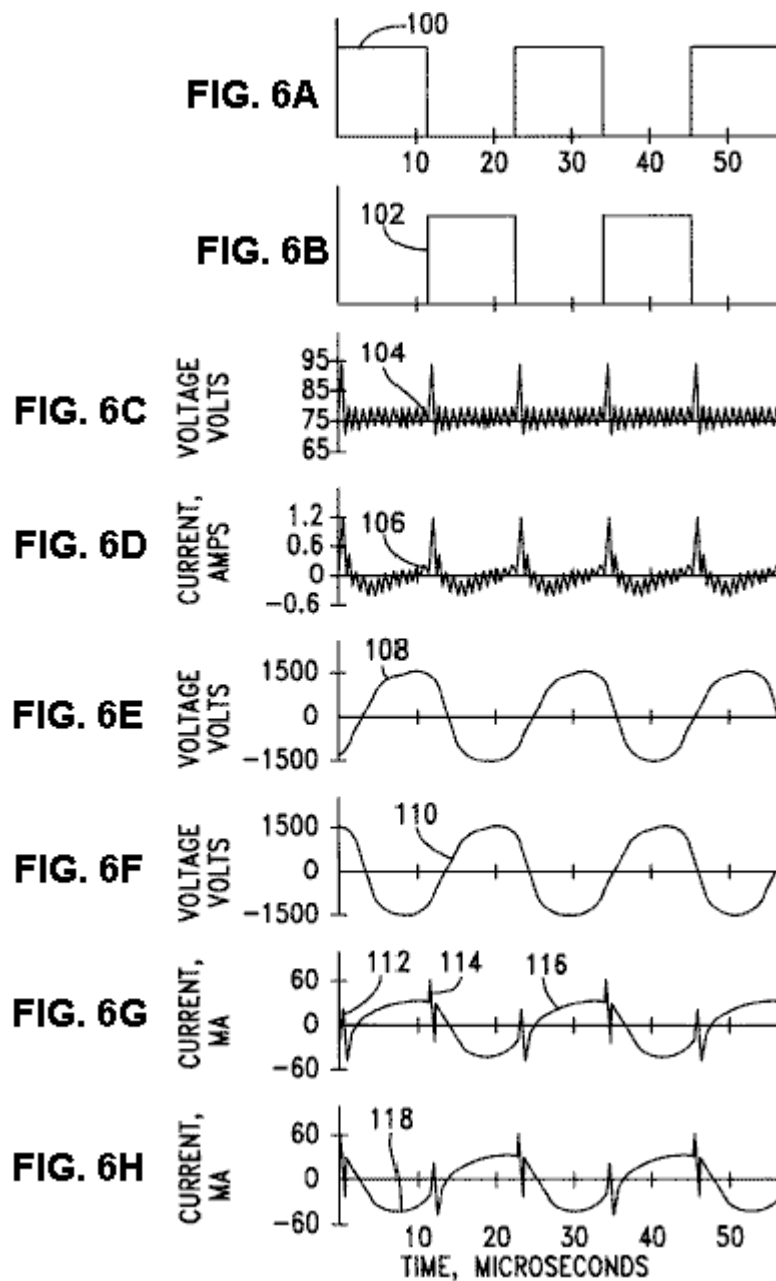

Figure 7 is a graphical view of output power measured within the apparatus of Figure 1, as a function of input voltage:

FIG. 7

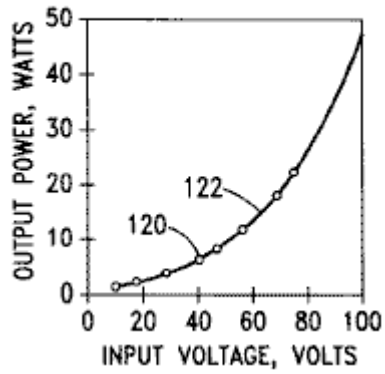

Figure 8 is a graphical view of a coefficient of performance, calculated from measurements within the apparatus of Figure 1, as a function of input voltage:

FIG. 8

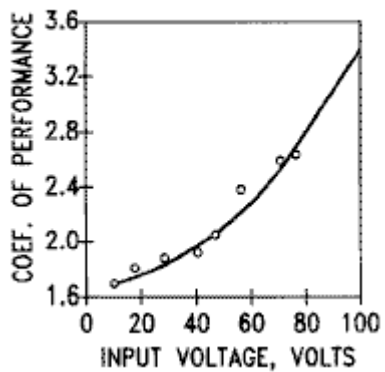

Figure 9 is a cross-sectional elevation of a second version of the first embodiment of the present invention:

FIG. 9

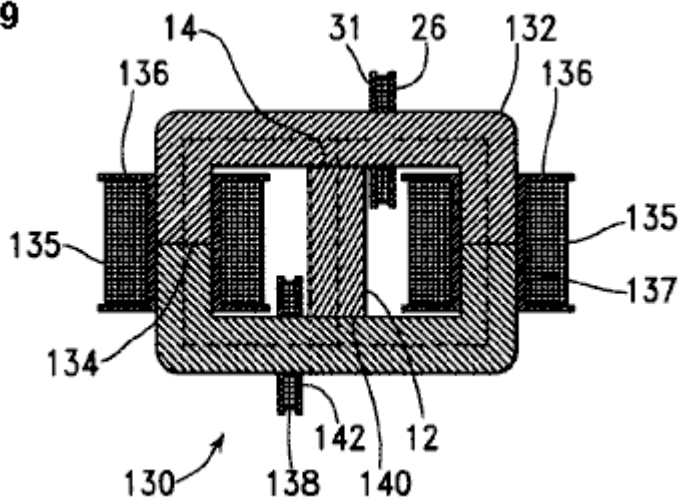

Figure 10 is a top view of a magnetic generator built in accordance with a first version of a second embodiment of the present invention:

FIG. 10

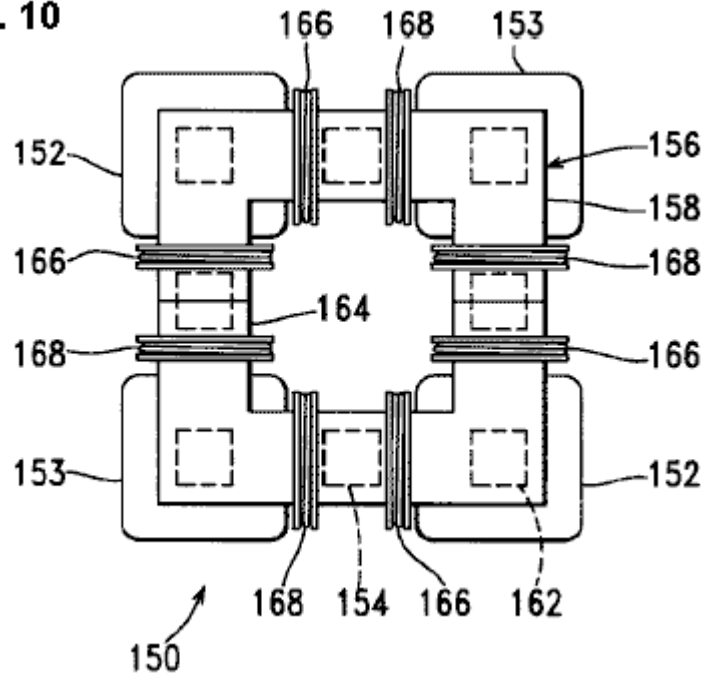

Figure 11 is a front elevation of the magnetic generator of Figure 10:

FIG. 11

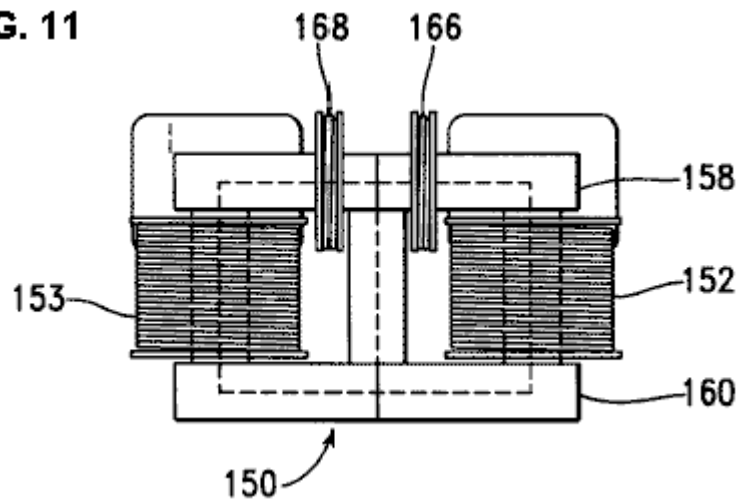
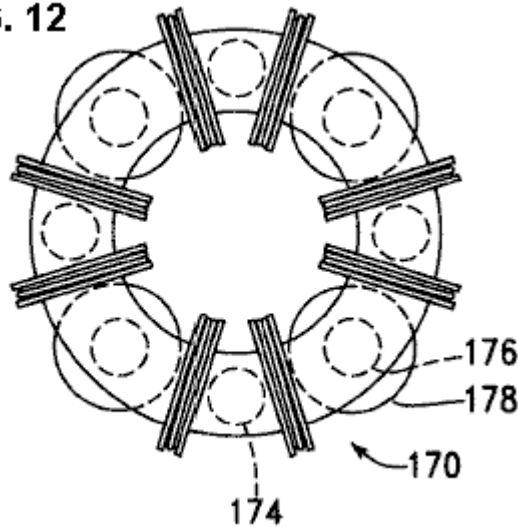

Figure 12 is a top view of a magnetic generator built in accordance with a second version of the second embodiment of the present invention:

FIG. 12



DETAILED DESCRIPTION OF THE INVENTION:

Fig.1 is a partly schematic front elevation, of an electromagnetic generator **10**, built in accordance with a first embodiment of the present invention, to include a permanent magnet **12** to supply input lines of magnetic flux moving from the north pole **14** of the magnet **12**, outward into magnetic flux path core material **16**.

The flux path core material **16** is configured to form a right magnetic path **18** and a left magnetic path **20**, both of which extend externally between the north pole **14** and the south pole **22** of the magnet **12**.

The electromagnetic generator **10** is driven by means of a switching and control circuit **24**, which alternately drives electrical current through a right input coil **26** and a left input coil **28**. These input coils each extend around a portion of the core material **16**, with the right input coil **26** surrounding a portion of the right magnetic path **18** and with the left input coil **28** surrounding a portion of the left magnetic path **20**. A right output coil **29** also surrounds a portion of the right magnetic path **18**, while a left output coil **30** surrounds a portion of the left magnetic path **20**.

In accordance with a preferred version of the present invention, the switching and control circuit **24** and the input coils **26**, **28** are arranged so that, when the right input coil **26** is energised, a north magnetic pole is present at its left end **31**, the end closest to the north pole **14** of the permanent magnet **12**, and so that, when the left input coil **28** is energised, a north magnetic pole is present at its right end **32**, which is also the end closest to the north pole **14** of the permanent magnet **12**. Thus, when the right input coil **26** is magnetised, magnetic flux from the permanent magnet **12** is repelled from extending through the right input coil **26**. Similarly, when the left input coil **28** is magnetised, magnetic flux from the permanent magnet **12** is repelled from extending through the left input coil **28**.

Thus, it is seen that driving electrical current through the right input coil **26** opposes a concentration of flux from the permanent magnet **12** within the right magnetic path **18**, causing at least some of this flux to be transferred to the left magnetic path **20**. On the other hand, driving electrical current through the left input coil **28** opposes a concentration of flux from the permanent magnet **12** within the left magnetic path **20**, causing at least some of this flux to be transferred to the right magnetic path **18**.

While in the example of **Fig.1**, the input coils **26**, **28** are placed on either side of the north pole of the permanent magnet **12**, being arranged along a portion of the core **16** extending from the north pole of the permanent magnet **12**, it is understood that the input coils **26**, **28** could as easily be alternately placed on either side of the south pole of the permanent magnet **12**, being arranged along a portion of the core **16** extending from the south pole of the permanent magnet **12**, with the input coils **26**, **28** being wired to form, when energised, magnetic fields having south poles directed toward the south pole of the permanent magnet **12**. In general, the input coils **26**, **28** are arranged along the magnetic core on either side of an end of the permanent magnet forming a first pole, such as a north pole, with the input coils being arranged to produce magnetic fields of the polarity of the first pole directed toward the first pole of the permanent magnet.

Further in accordance with a preferred version of the present invention, the input coils **26**, **28** are never driven with so much current that the core material **16** becomes saturated. Driving the core material **16** to saturation means that subsequent increases in input current can occur without effecting corresponding changes in magnetic flux, and therefore that input power can be wasted. In this way, the apparatus of the present

invention is provided with an advantage in terms of the efficient use of input power over the apparatus of U.S. Patent No. 4,000,401, in which a portion both ends of each magnetic path is driven to saturation to block flux flow.

In the electromagnetic generator **10**, the switching of current flow within the input coils **26, 28** does not need to be sufficient to stop the flow of flux in one of the magnetic paths **18, 20** while promoting the flow of magnetic flux in the other magnetic path. The electromagnetic generator **10** works by changing the flux pattern; it does not need to be completely switched from one side to another.

Experiments have determined that this configuration is superior, in terms of the efficiency of using power within the input coils **26, 28** to generate electrical power within the output coils **29, 30**, to the alternative of arranging input coils and the circuits driving them so that flux from the permanent magnet is driven through the input coils as they are energised. This arrangement of the present invention provides a significant advantage over the prior-art methods shown, for example, in U.S. Patent No. 4,077,001, in which the magnetic flux is driven through the energised coils.

The configuration of the present invention also has an advantage over the prior-art configurations of U.S. Patent Nos. 3,368,141 and 4,077,001 in that the magnetic flux is switched between two alternate magnetic paths **18, 20** with only a single input coil **26, 28** surrounding each of the alternate magnetic paths. The configurations of U.S. Patent Nos. 3,368,141 and 4,077,001 each require two input coils on each of the magnetic paths. This advantage of the present invention is significant both in the simplification of hardware and in increasing the efficiency of power conversion.

The right output coil **29** is electrically connected to a rectifier and filter **33**, having an output driven through a regulator **34**, which provides an output voltage adjustable through the use of a potentiometer **35**. The output of the linear regulator **34** is in turn provided as an input to a sensing and switching circuit **36**. Under start up conditions, the sensing and switching circuit **36** connects the switching and control circuit **24** to an external power source **38**, which is, for example, a starting battery. After the electromagnetic generator **10** is properly started, the sensing and switching circuit **36** senses that the voltage available from regulator **34** has reached a predetermined level, so that the power input to the switching and control circuit **24** is switched from the external power source **38** to the output of regulator **34**. After this switching occurs, the electromagnetic generator **10** continues to operate without an application of external power.

The left output coil **30** is electrically connected to a rectifier and filter **40**, the output of which is connected to a regulator **42**, the output voltage of which is adjusted by means of a potentiometer **43**. The output of the regulator **42** is in turn connected to an external load **44**.

Fig.2 is a schematic view of a first version of the switching and control circuit **24**. An oscillator **50** drives the clock input of a flip-flop **54**, with the Q and Q' outputs of the flip-flop **54** being connected through driver circuits **56, 58** to power FETs **60, 62** so that the input coils **26, 28** are driven alternately. In accordance with a preferred version of the present invention, the voltage V applied to the coils **26, 28** through the FETs **60, 62** is derived from the output of the sensing and switching circuit **36**.

Fig.3 is a graphical view of the signals driving the gates of FETs **60, 62** of **Fig.2**, with the voltage driving the gate of FET **60** being represented by line **64**, and with the voltage driving FET **62** being represented by line **66**. Both of the coils **26, 28** are driven with positive voltages.

Fig.4 is a schematic view of a second version of the switching and control circuit **24**. In this version, an oscillator **70** drives the clock input of a flip-flop **72**, with the Q and Q' outputs of the flip-flop **72** being connected to serve as triggers for one-shots **74, 76**. The outputs of the one-shots **74, 76** are in turn connected through driver circuits **78, 80** to drive FETs **82, 84**, so that the input coils **26, 28** are alternately driven with pulses shorter in duration than the Q and Q' outputs of the flip flop **72**.

Fig.5 is a graphical view of the signals driving the gates of FETs **82, 84** of **Fig.4**, with the voltage driving the gate of FET **82** being represented by line **86**, and with the voltage driving the gate of FET **84** being represented by line **88**.

Referring again to **Fig.1**, power is generated in the right output coil **29** only when the level of magnetic flux is changing in the right magnetic path **18**, and in the left output coil **30** only when the level of magnetic flux is changing in the left magnetic path **20**. It is therefore desirable to determine, for a specific magnetic generator configuration, the width of a pulse providing the most rapid practical change in magnetic flux, and then to provide this pulse width either by varying the frequency of the oscillator **50** of the apparatus of **Fig.2**, so that this pulse width is provided with the signals shown in **Fig.3**, or by varying the time constant of the one-shots **74, 76** of **Fig.4**, so that this pulse width is provided by the signals of **Fig.5** at a lower oscillator frequency. In this way, the input coils are not left on longer than necessary. When either of the input coils is left on for a

period of time longer than that necessary to produce the change in flux direction, power is being wasted through heating within the input coil without additional generation of power in the corresponding output coil.

A number of experiments have been conducted to determine the adequacy of an electromagnetic generator built as the generator **10** in **Fig.1**, to produce power both to drive the switching and control logic, providing power to the input coils **26**, **28**, and to drive an external load **44**. In the configuration used in this experiment, the input coils **26**, **28** had 40 turns of 18-gauge copper wire, and the output coils **29**, **30** had 450 turns of 18-gauge copper wire. The permanent magnet **12** had a height of 40 mm (1.575 in. between its north and south poles, in the direction of arrow **89**, a width of 25.4 mm (1.00 in.), in the direction of arrow **90**, and in the other direction, a depth of 38.1 mm (1.50 in.). The core **16** had a height, in the direction of arrow **89**, of 90 mm (3.542 in.), a width, in the direction of arrow **90**, of 135 mm (5.315 in.) and a depth of 70 mm (2.756 in.). The core **16** had a central hole with a height, in the direction of arrow **89**, of 40 mm (1.575 mm) to accommodate the magnet **12**, and a width, in the direction of arrow **90**, of 85 mm (3.346 in.). The core **16** was fabricated of two "C"-shaped halves, joined at lines **92**, to accommodate the winding of output coils **29**, **30** and input coils **26**, **28** over the core material.

The core material was a laminated iron-based magnetic alloy sold by Honeywell as METGLAS Magnetic Alloy 2605SA1. The magnet material was a combination of iron, neodymium, and boron.

The input coils **26**, **28** were driven at an oscillator frequency of 87.5 KHz, which was determined to produce optimum efficiency using a switching control circuit configured as shown in **Fig.2**. This frequency has a period of 11.45 microseconds. The flip flop **54** is arranged, for example, to be set and reset on rising edges of the clock signal input from the oscillator, so that each pulse driving one of the FETs **60**, **62** has a duration of 11.45 microseconds, and so that sequential pulses are also separated to each FET are also separated by 11.45 microseconds.

Fig.6A to **Fig.6H**, are graphical views of signals which occurred simultaneously during the operation of the apparatus shown in **Fig.1** and **Fig.2**, when the input voltage applied was 75 volts. **Fig.6A** shows a first drive signal **100** driving FET **60**, which conducts to drive the right input coil **26**. **Fig.6B** shows a second drive signal **102**, driving FET **62**, which, when it conducts, provides the drive to the left input coil **28**.

Fig.6C and **Fig.6D** show voltage and current signals produced when the current driving the FETs **60**, **62** is provided from a battery source. **Fig.6C** shows the level **104** of voltage V. While the nominal voltage of the battery was 75 volts, a decaying transient signal **106** is superimposed on this voltage each time one of the FETs **60**, **62** is switched on. The specific pattern of this transient signal depends on the internal resistance of the battery, as well as on a number of characteristics of the magnetic generator **10**. Similarly, **Fig.6D** shows the current **106** flowing into FETs **60**, **62** from the battery source. Since the signals **104**, **106** show the effects of current flowing into both FETs **60**, **62** the transient spikes are 11.45 microseconds apart.

Figs.6E to **6H**, show the voltage and current levels measured at the output coils **29**, **30**. **Fig.6E** shows a voltage output signal **108** of the right output coil **29**, while **Fig.6F** shows a voltage output signal **110** of the left output coil **30**. For example, the output current signal **116** of the right output coil **29** includes a first transient spike **112** caused when a pulse of current is generated in the left input coil **28** in order to boost the magnetic flux passing through the right magnetic path **18**, and a second transient spike **114** caused when the left input coil **28** is turned off as the right input coil **26** is being turned on. **Fig.6G** shows an output current signal **116** of the right output coil **29**, while **Fig.6H** shows an output current signal **118** of the left output coil **30**.

Fig.7 is a graphical view of output power measured using the electromagnetic generator **10** and eight levels of input voltage, varying from 10v to 75v. The oscillator frequency was retained at 87.5 KHz. The measured values are represented by points **120**, while the curve **122** is generated by polynomial regression, (a least squares fit).

Fig.8 is a graphical view of a coefficient of performance, defined as the ratio of the output power to the input power, for each of the measurement points shown in **Fig.7**. At each measurement point, the output power was substantially higher than the input power. Real power measurements were computed at each data point using measured voltage and current levels, with the results being averaged over the period of the signal. These measurements agree with RMS power measured using a Textronic THS730 digital oscilloscope.

While the electromagnetic generator **10** was capable of operation at much higher voltages and currents without saturation, the input voltage was limited to 75 volts because of voltage limitations of the switching circuits being used. Those familiar with electronics will understand that components for switching circuits capable of handling higher voltages are readily available for use in this application.

The experimentally-measured data were extrapolated to predict operation at an input voltage of 100 volts, with the input current being 140 mA, the input power being 14 watts, and with a resulting output power being

48 watts for each of the two output coils **29, 30**, at an average output current of 12 mA and an average output voltage of 4000 volts. This means that for each of the output coils **29, 30**, the coefficient of performance (“COP”) would be 3.44.

While an output voltage of 4000 volts may be needed for some applications, the output voltage can also be varied through a simple change in the configuration of the electromagnetic generator **10**. The output voltage is readily reduced by reducing the number of turns in the output windings. If this number of turns is decreased from 450 to 12, the output voltage is dropped to 106.7, with a resulting increase in output current to 0.5 amps for each output coil **29, 30**, (i.e. 53 watts). In this way, the output current and voltage of the electromagnetic generator can be varied by varying the number of turns of the output coils **29, 30**, without making a substantial change in the output power, which is instead determined by the input current, which determines the amount of magnetic flux shuttled during the switching process.

All of the **Coefficients Of Performance** were significantly greater than 1. These are plotted in **Fig.8** and they indicate that the output power levels measured in each of the output coils **29, 30** were substantially greater than the corresponding input power levels driving both of the input coils **26, 28**. Therefore, it is apparent that the electromagnetic generator **10** can be built in a self-powered form, as discussed above in reference to **Fig.1**. In the example of **Fig.1**, except for a brief application of power from the external power source **38** to start the process of power generation, the power required to drive the input coils **26, 28** is derived entirely from power developed within the right output coil **29**. If the power generated in the single output coil **29**, is more than sufficient to drive the input coils **26, 28**, an additional load **126** may be added to be driven with power generated in the output coil **29**. On the other hand, each of the output coils **29, 30** may be used to drive a portion of the input coil power requirements, for example, output coils **26** can provide the driving voltage *V* for FET **60** while output coil **28** can provide the driving voltage *V* for FET **62**.

Regarding thermodynamic considerations, it is noted that when the electromagnetic generator **10** is operating, it is an open system not in thermodynamic equilibrium. The system receives static energy from the magnetic flux of the permanent magnet. Because the electromagnetic generator **10** is self-switched without an additional energy input, the thermodynamic operation of the system is an open dissipative system, receiving, collecting, and dissipating energy from its environment; in this case, from the magnetic flux stored within the permanent magnet. Continued operation of the electromagnetic generator **10** causes demagnetisation of the permanent magnet. The use of a magnetic material including rare earth elements, such as a samarium cobalt material or a material including iron, neodymium, and boron is preferable within the present invention, since such a magnetic material has a relatively long life in this application.

Thus, an electromagnetic generator operating in accordance with the present invention should not be considered as a perpetual-motion machine, but rather as a system in which flux radiated from a permanent magnet is converted into electricity, which is used both to power the apparatus and to power an external load. This is analogous to a system including a nuclear reactor, in which a number of fuel rods radiate energy which is used to keep the chain reaction going and to heat water for the generation of electricity to drive external loads.

Fig.9 is a cross-sectional elevation of an electromagnetic generator **130** built in accordance with a second version of the first embodiment of the present invention. This electromagnetic generator **130** is generally similar in construction and operation to the electromagnetic generator **10** built in accordance with the first version of this embodiment, except that the magnetic core **132** of the electromagnetic generator **10** is built in two halves joined along lines **134**, allowing each of the output coils **135** to be wound on a plastic bobbin **136** before being placed over the legs **137** of the core **132**.

Fig.9 also shows an alternate placement of an input coil **138**. In the example of **Fig.1**, both of the input coils **26, 28** were placed on the upper portion of the magnetic core **16**, with these coils being configured to generate magnetic fields having north magnetic poles at the inner ends **31, 32** of the coils **26, 28**, with these north magnetic poles thus being closest to the end **14** of the permanent magnet **12** having its north magnetic pole. In the example of **Fig.9**, a first input coil **26** is as described above in reference to **Fig.1**, but the second input coil **138** is placed adjacent the south pole **140** of the permanent magnet **12**. This input coil **138** is configured to generate a south magnetic pole at its inner end **142**, so that, when input coil **138** is turned on, flux from the permanent magnet **12** is directed away from the left magnetic path **20** into the right magnetic path **18**.

Fig.10 and **Fig.11** show an electromagnetic generator **150** built in accordance with a first version of a second embodiment of the present invention, with **Fig.10** being a top view, and **Fig.11** being a front elevation. This electromagnetic generator **150** includes an output coil **152, 153** at each corner, and a permanent magnet **154** extending along each side between output coils. The magnetic core **156** includes an upper plate **158**, a lower plate **160**, and a square post **162** extending within each output coil **152, 153**. Both the upper plate **158** and the lower plate **160** include central apertures **164**.

Each of the permanent magnets **154** is oriented with a like pole, such as a north pole, against the upper plate **158**. Eight input coils **166, 168** are placed in positions around the upper plate **158** between an output coil **152, 153** and a permanent magnet **154**. Each input coil **166, 168** is arranged to form a magnetic pole at its end nearest to the adjacent permanent magnet **154** of the same polarity as the magnetic poles of the magnets **154** adjacent the upper plate **158**. Thus, the input coils **166** are switched on to divert the magnetic flux of the permanent magnets **154** from the adjacent output coils **152**, into magnetic paths through the output coils **153**. Then, the input coils **168** are switched on to divert magnetic flux of the permanent magnets **154** from the adjacent output coils **153**, with this flux being diverted into magnetic paths through the output coils **152**. Thus, the input coils form a first group of input coils **166** and a second group of input coils **168**, with these first and second groups of input coils being alternately energised in the manner described above in reference to **Fig.1** for the single input coils **26, 28**. The output coils produce current in a first train of pulses occurring simultaneously within coils **152** and in a second train of pulses occurring simultaneously within coils **153**.

Thus, driving current through input coils **166** causes an increase in flux from the permanent magnets **154** within the posts **162** extending through output coils **153** and a decrease in flux from the permanent magnets **154** within the posts **162** extending through output coils **152**. On the other hand, driving current through input coils **168** causes a decrease in flux from the permanent magnets **154** within the posts **162** extending through output coils **153** and an increase in flux from the permanent magnets **154** within the posts **162** extending through output coils **152**.

While the example of **Fig.10** and **Fig.11** shows all of the input coils **166,168** deployed along the upper plate **158**, it is understood that certain of these input coils **166, 168** could alternately be deployed around the lower plate **160**, in the manner generally shown in **Fig.9**, with one input coil **166, 168** being within each magnetic circuit between a permanent magnet **154** and an adjacent post **162** extending within an output coil **152, 153**, and with each input coil **166, 168** being arranged to produce a magnetic field having a magnetic pole like the closest pole of the adjacent permanent magnet **154**.

Fig.12 is a top view of a second version **170** of the second embodiment of the present invention, which is similar to the first version thereof, which has been discussed in reference to **Fig.10** and **Fig.11**, except that an upper plate **172** and a similar lower plate (not shown) are annular in shape, while the permanent magnets **174** and posts **176** extending through the output coils **178** are cylindrical. The input coils **180** are oriented and switched as described above in reference to **Fig.9** and **Fig.10**.

While the example of **Fig.12** shows four permanent magnets, four output coils and eight input coils it is understood that the principles described above can be applied to electromagnetic generators having different numbers of elements. For example, such a device can be built to have two permanent magnets, two output coils, and four input coils, or to have six permanent magnets, six output coils, and twelve input coils.

In accordance with the present invention, material used for magnetic cores is preferably a nanocrystalline alloy, and alternately an amorphous alloy. The material is preferably in a laminated form. For example, the core material is a cobalt-niobium-boron alloy or an iron based magnetic alloy.

Also in accordance with the present invention, the permanent magnet material preferably includes a rare earth element. For example, the permanent magnet material is a samarium cobalt material or a combination of iron, neodymium, and boron.

While the invention has been described in its preferred versions and embodiments with some degree of particularity, it is understood that this description has been given only by way of example and that numerous changes in the details of construction, fabrication, and use, including the combination and arrangement of parts, may be made without departing from the spirit and scope of the invention.

CLAIMS:

1. An electromagnetic generator comprising: a permanent magnet having magnetic poles at opposite ends; a magnetic core including first and second magnetic paths between said opposite ends of said permanent magnet, wherein said magnetic core comprises a closed loop, said permanent magnet extends within said closed loop, and said opposite ends of said permanent magnet are disposed adjacent opposite sides of said closed loop and against internal surfaces of said magnetic core comprising said closed loop; a first input coil extending around a portion of said first magnetic path, a second input coil extending around a portion of said second magnetic path, a first output coil extending around a portion of said first magnetic path for providing a first electrical output; a second output coil extending around a portion of said second magnetic path for providing a second electrical output; and a switching circuit driving electrical current alternately through said first and second input coils, wherein said electrical current driven through said first input coil causes said first input coil to produce a magnetic field opposing a concentration of magnetic flux

from said permanent magnet within said first magnetic path, and said electrical current driven through said second input coil causes said second input coil to produce a magnetic field opposing a concentration of magnetic flux from said permanent magnet within said second magnetic path.

2. An electromagnetic generator comprising: a permanent magnet having magnetic poles at opposite ends; a magnetic core including first and second magnetic paths between said opposite ends of said permanent magnet, wherein said magnetic core comprises a closed loop, said permanent magnet extends within said closed loop, said opposite ends of said permanent magnet are disposed adjacent opposite sides of said closed loop, and a first type of pole of said permanent magnet is disposed adjacent a first side of said closed loop; a first input coil, disposed along said first side of said closed loop, extending around a portion of said first magnetic path, a second input coil, disposed along said first side of said closed loop, extending around a portion of said second magnetic path, a first output coil extending around a portion of said first magnetic path for providing a first electrical output; a second output coil extending around a portion of said second magnetic path for providing a second electrical output; and a switching circuit driving electrical current alternately through said first and second input coils, wherein said electrical current driven through said first input coil causes said first input coil to produce a magnetic field opposing a concentration of magnetic flux from said permanent magnet within said first magnetic path, and additionally causes said first input coil to produce a magnetic field having said first type of pole at an end of said first input coil adjacent said permanent magnet, and said electrical current driven through said second input coil causes said second input coil to produce a magnetic field opposing a concentration of magnetic flux from said permanent magnet within said second magnetic path, and additionally causes said second input coil to produce a magnetic field having said first type of pole at an end of said of said second input coil adjacent said permanent magnet.
3. An electromagnetic generator comprising: a permanent magnet having magnetic poles at opposite ends; a magnetic core including first and second magnetic paths between said opposite ends of said permanent magnet, wherein said magnetic core comprises a closed loop, said permanent magnet extends within said closed loop, and said opposite ends of said permanent magnet are disposed adjacent opposite sides of said closed loop, a first type of pole of said permanent magnet is disposed adjacent a first side of said closed loop, and a second type of pole, opposite said first type of pole, of said permanent magnet is disposed adjacent a second side of said closed loop; a first input coil extending around a portion of said first magnetic path, wherein said first input coil is disposed along said first side of said closed loop; a second input coil extending around a portion of said second magnetic path wherein said second input coil is disposed along said second side of said closed loop; a first output coil extending around a portion of said first magnetic path for providing a first electrical output; a second output coil extending around a portion of said second magnetic path for providing a second electrical output; and a switching circuit driving electrical current alternately through said first and second input coils, wherein said electrical current driven through said first input coil causes said first input coil to produce a magnetic field opposing a concentration of magnetic flux from said permanent magnet within said first magnetic path, and additionally causes said first input coil to produce a magnetic field having said first type of pole at an end of said first input coil adjacent said permanent magnet, and said electrical current driven through said second input coil causes said second input coil to produce a magnetic field opposing a concentration of magnetic flux from said permanent magnet within said second magnetic path, and additionally causes said second input coil to produce a magnetic field having said second type of pole at an end of said of said second input coil adjacent said permanent magnet.
4. An electromagnetic generator comprising: a permanent magnet having magnetic poles at opposite ends; a magnetic core including first and second magnetic paths between said opposite ends of said permanent magnet; a first input coil extending around a portion of said first magnetic path, a second input coil extending around a portion of said second magnetic path, a first output coil extending around a portion of said first magnetic path for providing a first electrical output; a second output coil extending around a portion of said second magnetic path for providing a second electrical output; and a switching circuit driving electrical current alternately through said first and second input coils, wherein said electrical current driven through said first input coil causes said first input coil to produce a magnetic field opposing a concentration of magnetic flux from said permanent magnet within said first magnetic path, and wherein said electrical current driven through said second input coil causes said second input coil to produce a magnetic field opposing a concentration of magnetic flux from said permanent magnet within said second magnetic path, wherein a portion of electrical power induced in said first output coil provides power to drive said switching circuit.
5. The electromagnetic generator of claim 4, wherein said switching circuit is driven by an external power source during a starting process and by power induced in said first output coil during operation after said starting process.

6. The electromagnetic generator of claim 2, wherein said magnetic core is composed of a nanocrystalline magnetic alloy.
7. The electromagnetic generator of claim 6, wherein said nanocrystalline magnetic alloy is a cobalt-niobium-boron alloy.
8. The electromagnetic generator of claim 6, wherein said nanocrystalline magnetic alloy is an iron-based alloy.
9. The electromagnetic generator of claim 2, wherein said changes in flux density within said magnetic core occur without driving said magnetic core to magnetic saturation.
10. The electromagnetic generator of claim 2, wherein said switching circuit drives said electrical current through said first input coil in response to a first train of pulses, said switching circuit drives said electrical current through said second input coil in response to a second train of pulses, alternating with pulses within said first train of pulses, and said pulses in said first and second trains of pulses are approximately 11.5 milliseconds in duration.
11. The electromagnetic generator of claim 2, wherein said permanent magnet is composed of a material including a rare earth element.
12. The electromagnetic generator of claim 11, wherein said permanent magnet is composed essentially of samarium cobalt.
13. The electromagnetic generator of claim 11, wherein said permanent magnet is composed essentially of iron, neodymium, and boron.
14. An electromagnetic generator comprising: a magnetic core including a pair of spaced-apart plates, wherein each of said spaced-apart plates includes a central aperture, and first and second pluralities of posts extending between said spaced-apart plates; a plurality of permanent magnets extending individually between said pair of spaced-apart plates and between adjacent posts within said plurality of posts, wherein each permanent magnet within said plurality of permanent magnets has magnetic poles at opposite ends, wherein all magnets within said plurality of magnets are oriented to produce magnetic fields having a common direction; first and second pluralities of input coils, wherein each input coil within said first and second pluralities of input coils extends around a portion of a plate within said spaced-apart plates between a post in said plurality of posts and a permanent magnet in said plurality of permanent magnets; an output coil extending around each post in said first and second pluralities of posts for providing an electrical output; a switching circuit driving electrical current alternatively through said first and second pluralities of input coils, wherein said electrical current driven through each input coil in said first plurality of input coils causes an increase in magnetic flux within each post within said first plurality of posts from permanent magnets on each side of said post and a decrease in magnetic flux within each post within said second plurality of posts from permanent magnets on each side of said post, and wherein said electrical current driven through input coil in said second plurality of input coils causes a decrease in magnetic flux within each post within said first plurality of posts from permanent magnets on each side of said post and an increase in magnetic flux within each post within said second plurality of posts from permanent magnets on each side of said post.
15. The electromagnetic generator of claim 14, wherein each input coil extends around a portion of a magnetic path through said magnetic core between said opposite ends a permanent magnet adjacent said input coil, said magnetic path extends through a post within said magnetic core adjacent said input coil, and driving electrical current through said input coil causes said input coil to produce a magnetic field opposing a concentration of magnetic flux within said magnetic path.
16. The electromagnetic generator of claim 14, wherein said switching circuit is driven by an external power source during a starting process and by power induced in said output coils during operation after said starting process.
17. The electromagnetic generator of claim 14, wherein said magnetic core is composed of a nanocrystalline magnetic alloy.
18. The electromagnetic generator of claim 2, wherein a portion of electrical power induced in said first output coil provides power to drive said switching circuit.
19. The electromagnetic generator of claim 18, wherein said switching circuit is driven by an external power source during a starting process and by power induced in said first output coil during operation after said starting process.

20. The electromagnetic generator of claim 3, wherein a portion of electrical power induced in said first output coil provides power to drive said switching circuit.
21. The electromagnetic generator of claim 20, wherein said switching circuit is driven by an external power source during a starting process and by power induced in said first output coil during operation after said starting process.
22. The electromagnetic generator of claim 3, wherein said magnetic core is composed of a nanocrystalline magnetic alloy.
23. The electromagnetic generator of claim 22, wherein said nanocrystalline magnetic alloy is a cobalt-niobium-boron alloy.
24. The electromagnetic generator of claim 22, wherein said nanocrystalline magnetic alloy is an iron-based alloy.
25. The electromagnetic generator of claim 3, wherein said changes in flux density within said magnetic core occur without driving said magnetic core to magnetic saturation.
26. The electromagnetic generator of claim 3, wherein said switching circuit drives said electrical current through said first input coil in response to a first train of pulses, said switching circuit drives said electrical current through said second input coil in response to a second train of pulses, alternating with pulses within said first train of pulses, and said pulses in said first and second trains of pulses are approximately 11.5 milliseconds in duration.
27. The electromagnetic generator of claim 3, wherein said permanent magnet is composed of a material including a rare earth element.
28. The electromagnetic generator of claim 27, wherein said permanent magnet is composed essentially of samarium cobalt.
29. The electromagnetic generator of claim 27, wherein said permanent magnet is composed essentially of iron, neodymium, and boron.

ACOUSTIC-MAGNETIC POWER GENERATOR

Please note that this is a re-worded excerpt from this patent. If the content interests you, then you should obtain a full copy via the www.freepatentsonline.com web site. This patent describes an electrical device very similar to the MEG device, capable of powering itself while powering additional external items of equipment.

ABSTRACT

The Acoustic Magnetic Field Power Generator uses an acoustic signal focused into a permanent magnet to stimulate the nuclear structure of the magnet to cause the magnetic field of the permanent magnet to move or oscillate. This effect can be used to tap power from the oscillating magnetic field by putting a coil of wire in the oscillating field. When an alternating current signal generator is connected simultaneously to an acoustic transducer and a stimulating coil; whereby, both the acoustic transducer and the stimulating coil are located within the magnetic field of the magnet, the acoustic signal enhances the stimulating effect to the permanent magnet transformer. The acoustic transducer can be any acoustic generation device such as a piezoelectric, magnetostrictive, or other acoustic transducer. The combined effect of the acoustic signal and the stimulating coil increases the efficiency of permanent magnet induction transformers.

BACKGROUND OF THE INVENTION

The present invention relates to a solid state electrical generator having no moving parts. More particularly, the invention makes use of a new method of stimulating the nuclear material of a permanent magnet so that the electronic structure of the atom will vibrate and thus cause the magnetic field of the permanent magnet to oscillate. It is a well-known fact that an oscillating magnetic field will induce electrical current in a coil as was discovered by Michael Faraday in the last century. What is new in this invention, is the discovery of the ability of an acoustic field to stimulate the nuclear structure of a material to cause the electrons to wobble under the influence of the acoustic field. If the material is magnetic or temporarily magnetised by an external magnetic field then the magnetic field will vibrate under the stimulus of the acoustic field. If this effect is combined with a coil which is simultaneously stimulating the magnet then the efficiency of stimulating the permanent magnet's field is enhanced. If a pickup coil is placed in the oscillating magnetic field so as to create an induction transformer then the combination of the acoustic and magnetic stimulation will enhance the efficiency of the induction transformer.

The most relevant prior art known to the inventor comprises U.S. Pat. No. 4,904,926 (1990) to Mario Pasichinsky, entitled Magnet Motion Electrical Generator; and U.S. Pat. No. 4,077,001 (1978) to Frank Richardson, entitled Electromagnetic Converter With Stationary Variable-Reluctance Members; and U.S. Pat. No. 4,006,401 (1977) to de Rivas, entitled Electromagnetic Generator.

The above references to Pasichinsky, Richardson, and de Rivas, all use inductive methods to stimulate the motion of a permanent magnetic field. In the de Rivas invention, 'Electromagnetic Generator', the flux of the permanent magnet is "alternated by switching" using inductive coupling. In the Richardson disclosure an "energy conversion system" the flux of the permanent magnet is also "shifted" by inductive means. In the Pasichinsky disclosure, alternating magnetic coils induce flux changes in a closed magnetic circuit and output coils attached to the circuit are induced by the changing flux to produce a magnetic field. All of these devices are essentially variations of transformer design with permanent magnets as part of the transformer cores and all use magnetic induction. The transformer aspect of these references is the use of permanent magnets as the transformer core with coils wrapped around the magnetic core which are energised to produce oscillation or movement of the permanent magnet's field. The above references will, in this document, be called "permanent magnet transformers".

Other prior art relevant to the invention are U.S. Pat. No. 2,101,272 (1937) to H. J. Scott, entitled Combined Magnetostriction and Piezoelectric Selective Device; and U.S. Pat. No. 2,636,135 (1953) to R. L. Peek, Jr. entitled Stress Coupled Core and Crystal Transformer, and U.S. Pat. No. 2,834,943 (1958) to R. O. Gridale, et al entitled Mechanically Coupled Electromechanical and Magnetomechanical Transducers, and U.S. Pat. No. 3,246,287 (1966) to H. F. Benson entitled Piezoelectric Transformer, and U.S. Pat. No. 3,261,339 (1966) to H. P. Quinn entitled Magnetostrictive Transformer, and U.S. Pat. No. 3,274,406 (1966) to H. S. Sommers, Jr. entitled Acoustic Electromagnetic Device, and U.S. Pat. No. 3,309,628 (1967) to F. A. Olson entitled YIG Variable Acoustic Delay Line, and U.S. Pat. No. 3,457,463 (1969) to L. Balamuth entitled Method and Apparatus for Generating Electric Currents of Small Magnitude, and U.S. Pat. No. 4,443,731 (1984) to Butler et al. entitled Hybrid Piezoelectric and

Magnetostrictive Acoustic Wave Transducer, and U.S. Pat. No. 4,552,071 (1985) to R. B. Thompson entitled Method and Apparatus for Measuring Stress.

The reference to Peek cited above, takes advantage of the difference in operation of piezoelectric and magnetostrictive crystals to produce a response in one when stimulated by the other. The Peek patent does not use an acoustic wave to stimulate a permanent magnet as in the present invention.

The reference to Sommers cited above, is a transducer which uses a conductive bar or tube, which supports relatively slow helicon waves, placed next to a piezoelectric or magnetostrictive crystal. The transducer is designed in such a way as to either enhance the acoustic wave or the electric wave by interaction of the two materials. The Sommers patent does not use an acoustic wave to stimulate a permanent magnet to enhance to oscillation of the magnetic field as the present invention does.

The reference to Balmuth cited above, uses mechanically resonant reeds, rods, or chambers which are coupled to transducers that are piezoelectric, magnetostrictive, or transistorised. The electrical output of the transducers stimulates an electrical circuit when the resonator receives acoustic energy and again does not use an acoustic wave to stimulate a permanent magnet to enhance to oscillation of the magnetic field as the present invention does.

The reference to Olson cited above, uses an acoustically responsive material such as a piezoelectric or a magnetostrictive to act as a delay line for microwave signals and again does not use an acoustic wave to stimulate a permanent magnet to enhance to oscillation of the magnetic field as the present invention does.

The references to Benson, Quinn, Grisdale, Scott, and Butler cited above, are all concerned with acoustic transducers which convert acoustic pressure to an electrical signal or vice versa using only the piezoelectric and/or the magnetostrictive effect. The Benson patent is an underwater acoustic transformer which converts acoustic waves hitting a transducer into an electromagnetic field which excites a transformer. The Quinn patent uses a magnetostrictive effect to stimulate piezoelectric crystals to output a high voltage which is a reverse of the Benson patent. The Grisdale patent uses mechanically stacked piezoelectric or magnetostrictive crystals to produce a more efficient mechanical gyrator. The Scott patent uses an electrical oscillator to stimulate magnetostrictive rods which put pressure on piezoelectric crystals to output a high voltage from the piezoelectric crystals. The Butler patent uses a combined effect of piezoelectric and magnetostrictive crystals to produce an enhanced acoustic energy detector.

The reference to Thompson cited above, uses a permanent magnetic transducer to induce eddy currents in metal which is in the field of the transducer or uses moving eddy currents in a piece of metal to stimulate a magnetic field. The induction of the eddy currents is the result of an oscillating magnetic field generated in the transducer.

None of the references cited above, use an acoustic wave to stimulate the atoms of a permanent magnet and hence are not related to this invention.

SUMMARY OF THE INVENTION

An object of this invention is to provide a power generator with no moving parts.

Another object of this invention is to use an acoustic field to stimulate the nuclear level of the magnetic material and provide a method of oscillating the magnetic field of permanent magnets.

Another object of this invention is to provide a simple method of generating electrical energy by including a piezoelectric transducer which is used to vibrate the magnetic field of a permanent magnet. When the nucleus of the atom is vibrated by the piezoelectric, it in turn, vibrates the electronic structure of all the atoms. Since the electronic structure is the basis of the magnetic field of the magnet then the entire magnetic field of the magnet is vibrated when the electronic structure is vibrated. Coils placed in the vibrating magnetic field will have voltage and current induced in them.

It is a well established fact, that when the magnetic field of a permanent magnet is vibrated, it is possible to generate an alternating current in a coil winding placed within the vibrating magnetic field. What is unique about this invention, is to increase the efficiency of permanent magnet transformers by using acoustic stimulation from piezoelectrics to further stimulate the permanent magnet so as to add to the inductive effects of permanent magnet transformers. This invention does this by stimulating the permanent magnet cores of permanent magnet transformers with an acoustic field generated by a piezoelectric or other acoustically active generator which is vibrated at the same frequency as the electrical induction of the permanent magnet transformers.

BRIEF DESCRIPTION OF THE DRAWINGS

FIG.1 illustrates a frequency signal generator attached to and driving a piezoelectric transducer which is in the acoustic proximity of a bar type of permanent magnet with a output coil placed within the magnetic field of the permanent magnet.

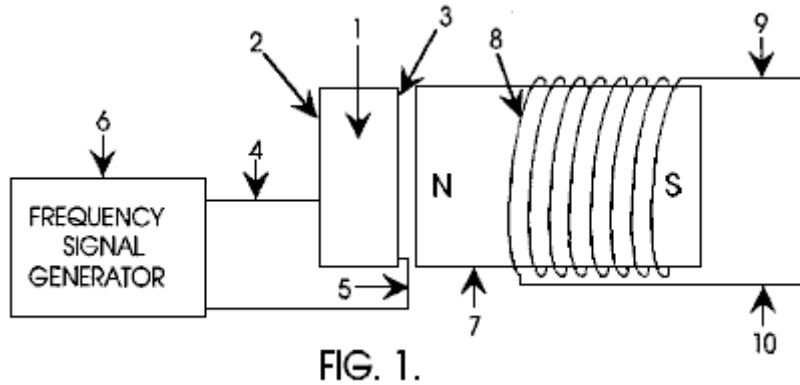

Fig.2 illustrates a frequency signal generator attached to and driving a piezoelectric transducer which is in the acoustic proximity of a toroidal type of permanent magnet with an output coil wrapped around the toroidal permanent magnet.

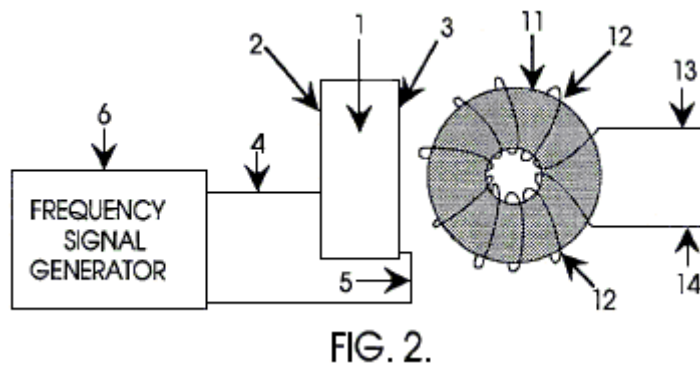

Fig.3 illustrates a frequency signal generator attached to and driving a piezoelectric transducer which is in the acoustic proximity of a toroidal type of permanent magnet transformer and the signal generator is also driving the input coil of the toroidal permanent magnet transformer.

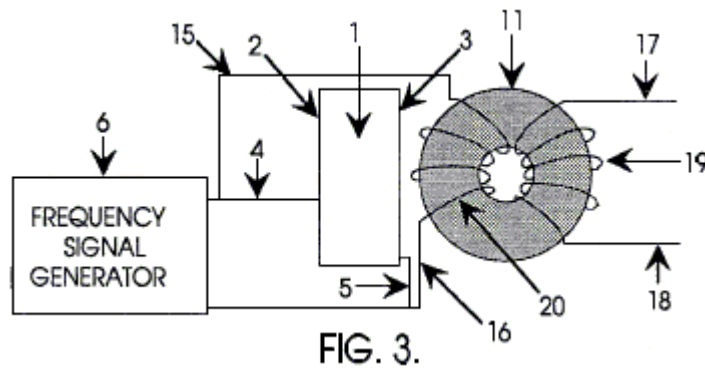

Fig.4 illustrates a frequency signal generator attached to and driving two toroidal core permanent magnet transformers as well as an acoustic transducer that is in acoustic proximity of the toroidal cores.

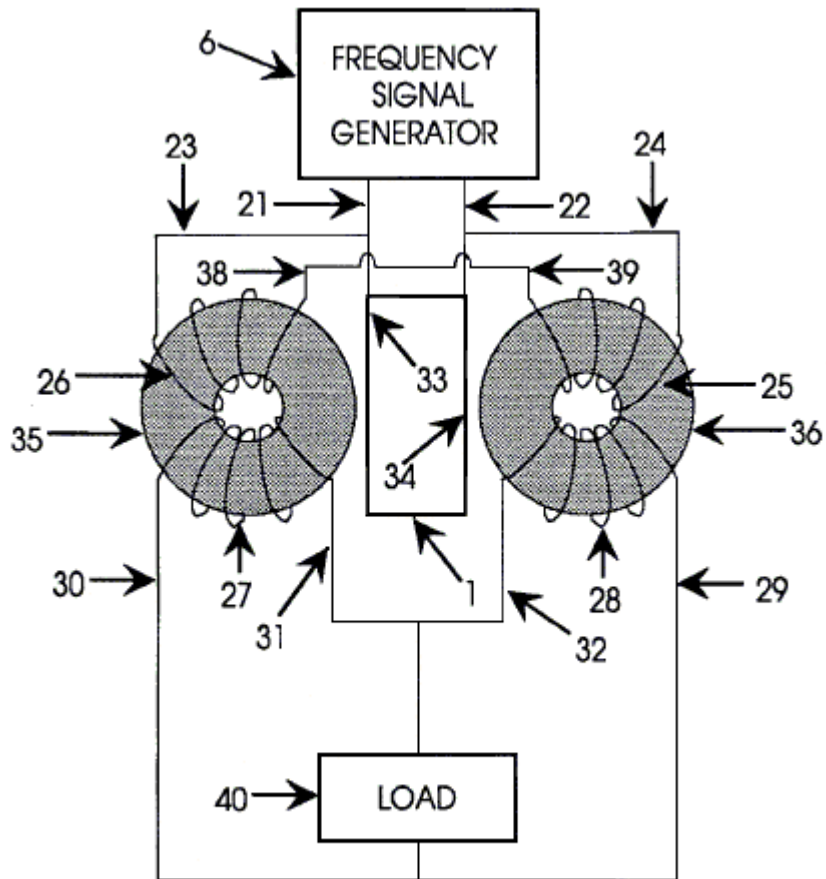

FIG. 4.

DETAILED DESCRIPTION OF THE INVENTION

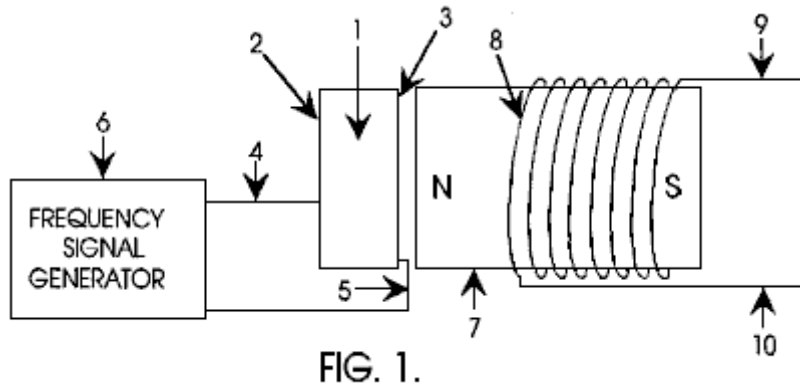

FIG. 1.

In **Fig.1**, a frequency signal generator **6** is connected to a piezoelectric transducer **1** via wires **4** and **5** connected to the electrode surfaces of the piezoelectric transducer **2** and **3** respectively. The piezoelectric transducer **1** is made from a high dielectric material such as barium titanate or lead zirconate titanate or any other acoustic transducer material suitable for sonic and ultrasonic generators. The piezoelectric transducer **1** is placed in close proximity to the permanent magnet **7** such that the acoustic field of the piezoelectric transducer **1** can radiate into the permanent magnet material. A permanent magnet transformer shown as coil **8** is positioned in the magnetic field of the permanent magnet **7**. When the piezoelectric transducer **1** is stimulated by the frequency generator **6** then a voltage and current is generated between the output leads **9** and **10** of the permanent magnet transformer.

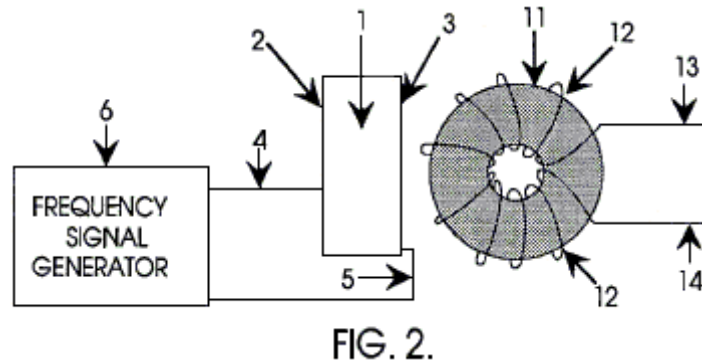

FIG. 2.

Another embodiment of this invention is shown in **Fig.2**, which is similar to **Fig.1**, with a similar frequency signal generator **6** connected to a piezoelectric material **1** via wires **4** and **5** connected to the electrode surfaces of the piezoelectric transducer **2** and **3**. The piezoelectric transducer **1** is as defined above, that is to say that it is constructed from a material suitable for sonic and ultrasonic generators. The piezoelectric transducer **1** is placed in close proximity to the permanent magnet **11** so that the acoustic field of the piezoelectric transducer **1** can radiate into the permanent magnet material. A permanent magnet transformer shown as coil **12** is placed in the magnetic field of the permanent magnet **11**. When the piezoelectric transducer **1** is stimulated by the frequency generator **6** then a voltage and current is generated between the output leads **13** and **14** of the above defined magnetic transformer.

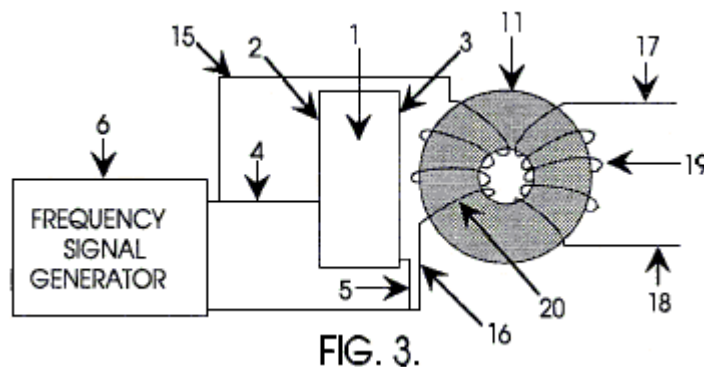

FIG. 3.

Fig.3 is similar to **Fig.1** and **Fig.2** with a frequency signal generator **6** connected to a piezoelectric transducer **1** via wires **4** and **5** connected to the electrode surfaces **2** and **3** of the piezoelectric transducer. The piezoelectric transducer **1** is as defined in the descriptions above. The signal generator **6** is also connected to the input coil **20**

of the permanent magnet transformer defined by the toroidal permanent magnet core **11**, input coil **20** and output coil **19**. The piezoelectric transducer **1** is placed in close proximity to the permanent magnet **11** so that the acoustic field of the piezoelectric transducer **1** can radiate into the permanent magnet material. The magnetic transformer defined by **11**, **19**, and **20** is in the magnetic field of the permanent magnet **11** and is connected to the frequency signal generator **6** via wires **15** and **16**. The frequency generator **6** stimulates the piezoelectric transducer **1** which stimulates the permanent magnet transformer via the acoustic field and at the same time the signal generator also stimulates the coil electromagnetically. A voltage and current is generated at the output coil **19** and power can be taken from the output wires **17** and **18** of the magnetic transformer.

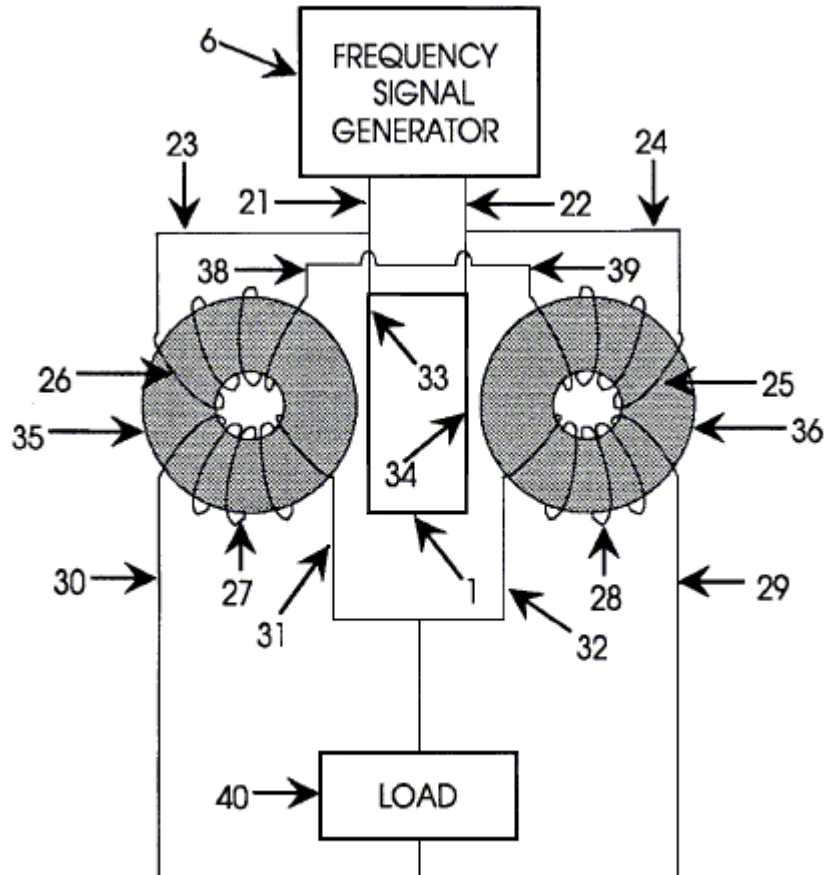

FIG. 4.

A further embodiment of this invention, shown in **Fig.4**, is a frequency signal generator **6** driving a pair of permanent magnet transformers defined by **26, 35, 27** and **25, 36, 28** respectively, also driving a piezoelectric transducer **1**. The piezoelectric transducer is as described above. The signal generator is connected via input wires **23** and **24** to the input coil **26** of the permanent magnet transformer on the left and to the input coil **25** of the transformer on the right respectively. The other input wire **38** of the left permanent magnet transformer is connected to the remaining input wire **39** of the right magnetic transformer. The output of the signal generator is also connected to the piezoelectric transducer **1** via connections **21** and **22** to the connector surface of the piezoelectric **33** and **34** respectively. The output of the permanent magnet transformer on the left is connected to a load **40** via wire **30** and the output of the permanent magnet transformer on the right is connected to the load via wire **29**. The remaining output wires **31** and **32** of the left and right permanent magnet transformers are also connected to the load. The load **40** can be anything such as a motor or electrical lights or any appliance.

This invention is not limited to the 4 different versions of the invention shown in **Figs. 1, 2, 3, and 4** as there are any number of cascading and electrical hook-up techniques that can be accomplished to amplify power and to take advantage of the acoustic influence of the piezoelectric upon the magnetic material. Similarly, this invention is not limited to the toroidal core configuration as there can be many types of permanent magnet transformers with any number of magnetic core and coil configurations that can be enhanced with acoustic stimulation depending on power and output requirements according to the rules of electronics and those familiar with the state of the art in permanent magnet power transformers.

CLAIMS

1. An acoustic magnetic power generator composed of an alternating current signal generator connected to an acoustic transducer which stimulates the core of a permanent magnet such that the atoms of the magnet are caused to vibrate which in turn causes the magnetic field to vibrate and causes a current and voltage to be generated in an output coil wrapped around a permanent magnet or in the magnetic field of the permanent magnet which said current and voltage can be used for powering a load.
2. An acoustic magnetic power generator composed of an alternating signal generator connected to an acoustic transducer which stimulates the core of a permanent magnet and causes the core to vibrate; the signal generator further connected to a drive coil surrounding the permanent magnet, and an output coil within the field of the permanent magnet which by induction generates an electrical output.
3. A method of causing the magnetic field of permanent magnet transformers to oscillate by the application of an acoustic signal applied to the atomic structure of permanent magnet.
4. A method of maximising the efficiency of permanent magnet transformers by stimulating the core material of the permanent magnet transformers with both an acoustic vibration and an electromagnetic signal simultaneously.

**DEVICE AND METHOD FOR UTILISING A MONOPOLE MOTOR
TO CREATE BACK-EMF TO CHARGE BATTERIES**

Please note that this is a re-worded excerpt from this patent. It describes a self-contained device which can charge an external battery or battery bank.

ABSTRACT

A back EMF monopole motor and method using a rotor containing magnets all of the same polarity and in a monopole condition when in momentary apposition with a magnetised pole piece of a stator having the same polarity, the stator being comprised of a coil with three windings: a power-coil winding, a trigger-coil winding, and a recovery-coil winding. The back EMF energy is rectified using a high voltage bridge, which transfers the back EMF energy to a high voltage capacitor for storage in a recovery battery. The stored energy can then be discharged across the recovery battery through the means of a contact rotor switch for further storage.

DESCRIPTION

Technical Field:

The invention relates generally to the capturing of available electromagnetic energy using a device and method for creating an electromagnetic force ('EMF') and then using the available stored energy for recycling into the system as stored energy. The method of creating back EMF is the result of coupling/uncoupling a coil to a voltage source.

Background:

The operation of present day normal magnetic motors, has the rotor pole attracting the stator pole, resulting in the generation of mechanical power from the magnets to the rotor and flywheel. During this phase, energy flows from the magnetics to the rotor/flywheel and is stored as kinetic energy in the increased rotation. A rotor pole leaving a stator pole and creating a condition of "drag" results in power having to be put back into the magnetic section by the rotor and flywheel to forcibly overcome the drag. In a perfect, friction-free motor, the net force field is therefore referred to as "most conservative". A most conservative EMF motor has maximum efficiency. Without extra energy continually fed to the motor, no net work can be done by the magnetic field, since half the time the magnetic field adds energy to the load (the rotor and flywheel) and the other half of the time it subtracts energy from the load (the rotor and flywheel). Therefore, the total net energy output is zero in any such rotary process without additional energy input. To use a present day magnetic motor, continuous energy must be fed to the motor to overcome drag and to power the motor and its load.

Motors and generators presently in use, all use such conservative fields and therefore, have internal losses. Hence, it is necessary to continually input all of the energy that the motor outputs to the load, plus more energy to cover losses inside the motor itself. EMF motors are rated for efficiency and performance by how much energy "input" into the motor actually results in "output" energy to the load. Normally, the Coefficient of Performance ('COP') rating is used as a measure of efficiency. The COP is the actual output energy going into the load and powering it, divided by the energy that must be input into the device with its motor/load combination. If there were zero internal losses in a motor, that "perfect" motor would have a COP equal to 1.0. That is, all energy input into the motor would be output by the motor directly into the load, and none of the input energy would be lost or dissipated in the motor itself.

In magnetic motor generators presently in use, however, due to friction and design flaws, there are always internal losses and inefficiencies. Some of the energy input into the motor is dissipated in these internal losses. As a consequence, the energy that gets to the load is always less than the input energy. So a standard motor operates with a COP of less than 1.0, which is expressed as $COP < 1.0$. An inefficient motor may have a COP of 0.4 or 0.45, while a specially designed and highly efficient motor may have a COP of 0.85.

The conservative field inside of a motor itself is divided into two phases. Producing a conservative field involves net symmetry between the "power out" phase from the magnetics to the rotor/flywheel and the "power back in" phase from the rotor/flywheel back to the magnetics. That is, the two flows of energy are identical in magnitude but opposite in direction. Each phase alone is said to be "asymmetrical", that is, it either has: 1) a net energy flow out to the rotor/flywheel; or 2) a net energy flow back into the magnetics from the rotor/flywheel. In simplified terms, it is referred to as "power out" and "power back in" phases with respect to the motor magnetics.

For the power-out phase, energy is derived from the EMF existing between the stator pole and incoming rotor pole in an attraction mode. In this phase, the rotary motion (angular momentum and kinetic energy) of the rotor and flywheel is increased. In short, power is added to the rotor/flywheel (and thus to the load) from the fields between stator pole and rotor pole (the electromagnetic aspects of the system).

For the "power back in" phase, energy must be fed back into the magnetics from the rotor and flywheel (and the load) to overcome the drag forces existing between stator pole and outgoing rotor pole. In this phase, energy is returned to the internal magnetic system from the rotary motion of the rotor and flywheel (the angular momentum, which is the rotational energy multiplied by time). As is well known in physics, a rotor/flywheel's angular momentum provides a convenient way to store energy with the spinning rotor/flywheel mass acting as an energy reservoir.

Most present day conventional magnetic motors use various methods for overcoming and partially reversing back EMF. Back EMF may be defined as the return pulse from the coil out of phase and is the result of re-gauging, which is the process of reversing the magnetics polarity, that is, from North to South, etc. The back EMF is shorted out and the rotor is attracted back in, therefore eliminating drag. This can be accomplished by pouring more energy in, which overpowers the back EMF, thereby producing a forward EMF in that region. The energy required for this method is furnished by the operator.

It is well known that changing the voltage alone creates a back EMF and requires no work. This is because to change the potential energy does not require changing the form of that potential energy, but only its magnitude. Work is the changing of the form of energy. Therefore, as long as the form of the potential energy is not changed, the magnitude can be changed without having to perform work in the process. The motor of the present invention takes advantage of this permissible operation to create back EMF asymmetrically, and thereby change its own usable available potential energy.

In an electric power system, the potential (voltage) is changed by inputting energy to do work on the internal charges of the generator or battery. This potential energy is expended within the generator (or battery) to force the internal charges apart, forming a source dipole. Then the external closed circuit system connected to that source dipole ineptly pumps the spent electrons in the ground line back through the back EMF of the source dipole, thereby scattering the charges and killing the dipole. This shuts off the energy flow from the source dipole to the external circuit. As a consequence of this conventional method, it is a requirement to input and replace additional energy to again restore the dipole. The circuits currently utilised in most electrical generators have been designed to keep on destroying the energy flow by continually scattering all of the dipole charges and terminating the dipole. Therefore, it is necessary to keep on inputting energy to the generator to keep restoring its source dipole.

A search of prior art failed to reveal any monopole motor devices and methods that recycle available energy from back EMF to charge a battery or provide electrical energy for other uses as described in the present invention. However, the following prior art patents were reviewed:
U.S. Pat. No. 4,055,789 to Lasater, Battery Operated Motor with Back EMF Charging.
U.S. Pat. No. 2,279,690 to Z. T. Lindsey, Combination Motor Generator.

SUMMARY OF THE INVENTION

An aspect of the device and method of the present invention is a new monopole electromagnetic motor that captures back EMF energy. The captured back EMF energy may be used to charge or store electrical energy in a recovery battery. The amount of energy recoverable, as expressed in watts, is dependent upon the configuration, circuitry, switching elements and the number and size of stators, rotors, magnets and coils which comprise the motor.

The motor uses a small amount of energy from a primary battery to "trigger" a larger input of available energy by supplying back EMF, thus increasing the potential energy of the system. The system then utilises this available potential energy to reduce, or reverse, the back EMF, thereby increasing the efficiency of the motor and, therefore, the COP.

If the energy in phase 1 (the power-out phase) is increased by additional available energy in the electromagnetics themselves, then the energy in phase 1 can be made greater than the energy in phase 2 (the power-back-in phase) without the operator furnishing the energy utilised. This produces a non-conservative nett field. Nett power can then be taken from the rotating stator and flywheel, because the available energy added into the stator and flywheel by the additional effects, is transformed by the rotor/flywheel into excess angular momentum and stored as such. Angular momentum is conserved at all times, but now, some of the angular momentum added to the flywheel, is evoked by additional effects in the electromagnetics, rather than being furnished by the operator.

That is, the motor is designed to deliberately create a back EMF itself, and thus increase its potential energy, thereby retaining each extra force for a period of time and applying it to increase the angular momentum and kinetic energy of the rotor and flywheel. Specifically, this back EMF energy with its nett force is deliberately applied in the motor of the present invention to overcome and even reverse the conventional drag-back (the back EMF). Hence, less energy needs to be taken from the rotor and flywheel to overcome the reduced back EMF, and in the ideal case, none is required since the back EMF has been overpowered and converted to forward EMF by the back EMF energy and force. In the motor, the conventional drag section of the magnetics becomes a forward-EMF section and now adds energy to the rotor/flywheel instead of reducing it. The important feature is that the operator only pays for the small amount of energy necessary to trigger the back EMF from the primary battery, and does not have to furnish the much larger back EMF energy itself.

Thus, when the desired energy in phase 1 (the power-out phase) is made greater than the undesired drag energy in phase 2, then part of the output power normally taken from the rotor and flywheel by the fields in phase 2, is not required. Hence, in comparison to a system without special back EMF mechanisms, additional power is available from the rotor/flywheel. The rotor therefore maintains additional angular momentum and kinetic energy, compared to a system which does not produce back EMF itself. Consequently, the excess angular momentum retained by the rotor and flywheel can be utilised as additional shaft power to power an external load.

In this motor, several known processes and methods are utilised. These allow the motor to operate periodically as an open dissipative system (receiving available excess energy from back EMF) far from thermodynamic equilibrium, whereby it produces and receives its excess energy from a known external source.

A method is utilised to temporarily produce a much larger source of available external energy around an energised coil. Design features of this new motor provide a device and method that can immediately produce a second increase in that energy concurrently as the energy flow is reversed. Therefore, the motor is capable of producing two asymmetrical back EMFs, one after the other, of the energy within a single coil, which dramatically increases the energy available and causes that available excess energy to then enter the circuit as impulses which are collected and utilised.

The motor utilises this available excess back EMF energy to overcome and even reverse the drag EMF between stator pole and rotor pole, while furnishing only a small trigger pulse of energy from a primary battery necessary to control and activate the direction of the back EMF energy flow.

By using a number of such dual asymmetrical self back EMFs for every revolution of the rotor, the rotor and flywheel collectively focus all the excess impulsive inputs into increased angular momentum (expressed as energy multiplied by time), shaft torque, and shaft power.

Further, some of the excess energy deliberately generated in the coil by the utilisation of the dual process manifests in the form of excess electrical energy in the circuit and can be utilised to charge a recovery battery or batteries. The excess energy can also be used to power electrical loads or to power the rotor and flywheel, with the rotor/flywheel also furnishing shaft horsepower for powering mechanical loads.

The motor utilises a means to furnish the relatively small amount of energy from a primary battery to initiate the impulsive asymmetrical self back EMF actions. Then part of the available excess electrical power drawn off from back EMF created energy is utilised to charge a recovery battery with dramatically increased over-voltage pulses.

Design features of this monopole motor utilise one magnetic pole of each rotor and stator magnet. The number of impulsive self-back EMF in a single rotation of the rotor is doubled. Advanced designs can increase the number of self-back EMFs in a single rotor rotation with the result that there is an increase in the number of impulses per rotation, which increase the power output of this new motor.

The sharp voltage spike produced in the coil of this monopole motor by the rapidly collapsing field in the back EMF coil is connected to a recovery battery(s) in charge mode and to an external electrical load. The nett result is that the coil asymmetrically creates back EMF itself in a manner which adds available energy and impulse to the circuit. The available energy collected in the coil is used to reverse the back-EMF phase of the stator-rotor fields to a forward EMF condition, with the impulses adding acceleration and angular momentum to the rotor and flywheel. The available back EMF energy collected in the coil is used to charge a battery. Loads can then be driven by the battery.

A device and method in which the monopole motor alters the reaction cross section of the coils in the circuit, which briefly changes the reaction cross section of the coil in which it is invoked. Thus, since this new motor uses only a small amount of current in the form of a triggering pulse, it is able to evoke and control the immediate change of the coil's reaction cross section to this normally wasted energy-flow component. As a result, the motor captures and directs some of this usually wasted available environmental energy, collecting the available excess energy in the coil and then releasing it for use in the motor. Through timing and switching, the innovative gate

design of this new motor directs the available excess energy so that it overcomes and reverses the return EMF of the rotor-stator pole combination during what would normally be the back EMF and demonstrates the creation of the second back EMF of the system. Now, instead of an "equal retardation" force being produced in the back EMF region, a forward EMF is produced which adds to the rotor/flywheel energy, rather than subtracting from it. In short, it further accelerates the rotor/flywheel.

This results in a non-conservative magnetic field along the rotor's path. The line integral of the field around that path (i.e., the net work on the rotor/flywheel to increase its energy and angular momentum) is not zero but a significant amount. Hence, the creation of an asymmetrical back EMF impulse magnetic motor:

- 1) Takes its available excess energy from a known external source, the huge usually non-intercepted portion of the energy flow around the coil;
- 2) Further increases the source dipolarity by this back EMF energy; and
- 3) Produces available excess energy flow directly from the source dipole's increased broken symmetry in its fierce energy exchange with the local vacuum.

By operating as an open dissipative system, not in thermodynamic equilibrium with the active vacuum, the system can permissibly receive available energy from a known environmental source and then output this energy to a load. As an open dissipative system not in thermodynamic equilibrium, this new and unique monopole motor can tap in on back EMF to energise itself, loads and losses simultaneously, fully complying with known laws of physics and thermodynamics.

BRIEF DESCRIPTION OF THE DRAWINGS

Fig.1 is a perspective side view of a monopole back EMF motor with a single stator and a single rotor.

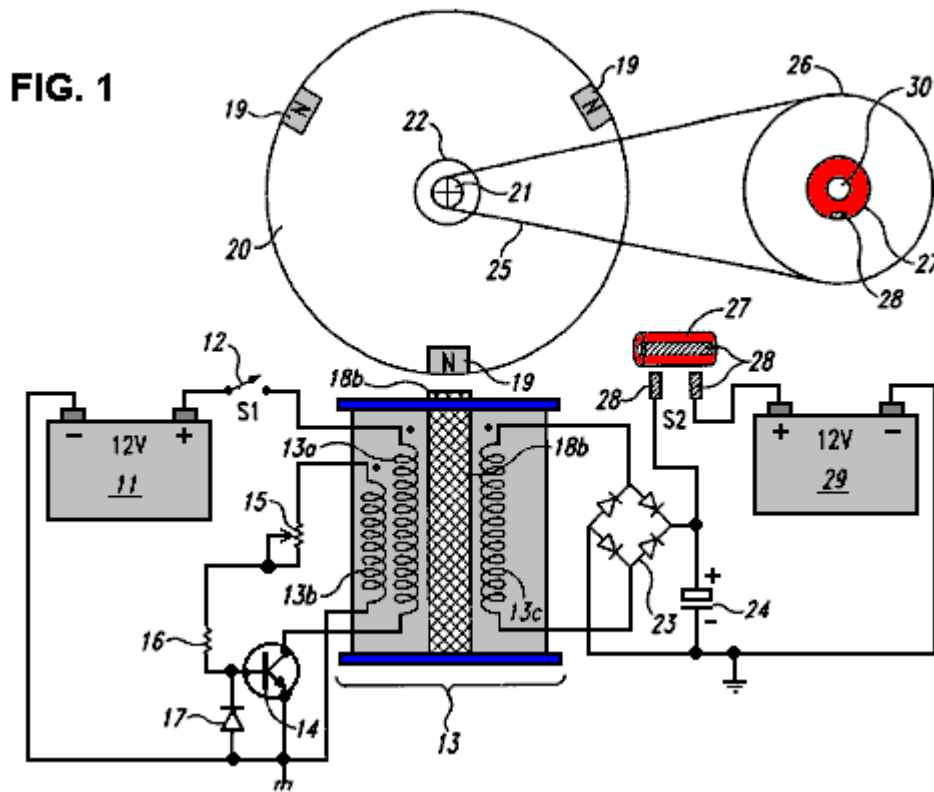

Fig.2 is a perspective top view of a monopole back EMF motor with a single stator and a single rotor.

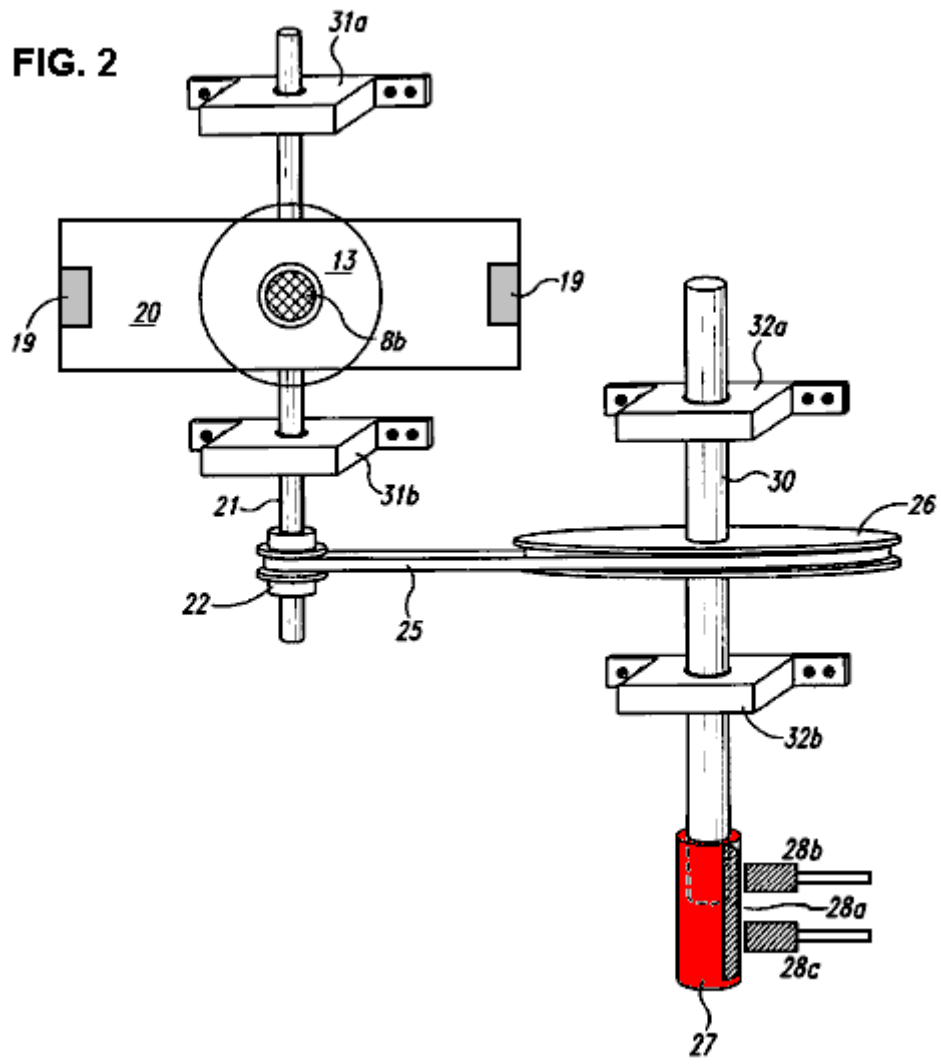
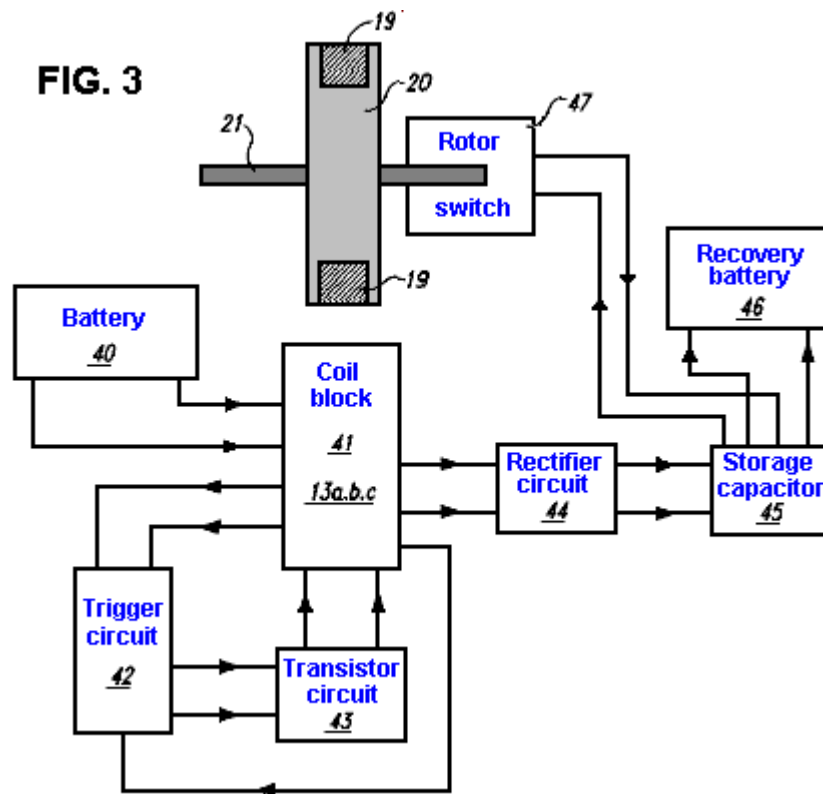

Fig.3 is a block diagram demonstrating the circuitry for a monopole back EMF motor.



DETAILED DESCRIPTION OF THE INVENTION

An embodiment of the present invention is a device and method for a monopole back EMF electromagnetic motor. As described in the Summary of the Invention, this monopole motor conforms to all applicable electrodynamic laws of physics and is in harmony with the law of the conservation of energy, the laws of electromagnetism and other related natural laws of physics.

The monopole back EMF electromagnetic motor comprises a combination of elements and circuitry to capture available energy (back EMF) in a recovery element, such as a capacitor, from output coils. The available stored energy in the recovery element is used to charge a recovery battery.

As a starting point, an arbitrary method in describing this device will be employed, namely, the flow of electrical energy and mechanical forces will be tracked from the energy's inception at the primary battery to its final storage in the recovery battery.

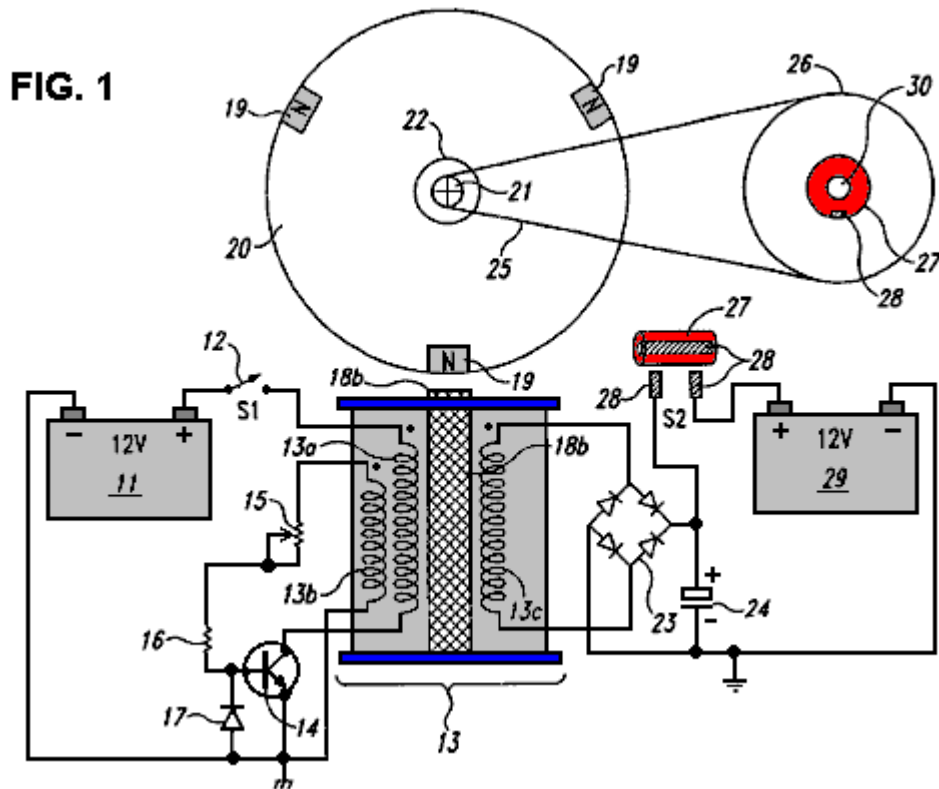

Fig.1 is a perspective side view of the monopole motor according to an embodiment of the invention. As shown in **Fig.1**, electrical energy from primary battery **11** periodically flows through power switch **12** and through power-coil wiring **13a**. In one embodiment, power switch **12** is merely an On-Off mechanical switch and is not electronic. However, the switch **12** may be a solid-state switching circuit, a magnetic Reed switch, a commutator, an optical switch, a Hall-effect switch, or any other conventional transistorised or mechanical switch. Coil **13** is comprised of three windings: power-coil winding **13a**, trigger-coil winding **13b**, and recovery-coil winding **13c**. However, the number of windings can be more or fewer than three, depending upon the size of the coil **13**, size of the motor and the amount of available energy to be captured, stored and used, as measured in watts. Electrical energy then periodically flows from power-coil winding **13a** and through transistor **14**.

Trigger energy also periodically flows through variable resistor **15** and resistor **16**. Clamping diode **17** clamps the reverse base-emitter voltage of transistor switch **14** at a safe reverse-bias level that does not damage the transistor. Energy flows to stator **18a** and pole piece **18b**, an extension of stator **18a**. Pole piece **18b** is electrically magnetised only when transistor switch **14** is on and maintains the same polarity as the rotor poles **19** - North pole in this instance - when electrically magnetised. The North rotor poles **19a**, **19b** and **19c**, which are attached to rotor **20**, come in momentary apposition with pole piece **18b** creating a momentary monopole interface. The poles **19a,b,c**, which are actually permanent magnets with their North poles facing outward from the rotor **20**, maintain the same polarity when in momentary alignment with pole piece **18b**.

Rotor **20** is attached to rotor shaft **21**, which has drive pulley **22**. Attached to rotor shaft **21** are rotor-shaft bearing blocks **31a** and **31b**, as seen in **Fig.2**. As rotor **20** begins to rotate, the poles **19a,b,c** respectively comes into alignment with magnetised pole piece **18b** in a momentary monopole interface with energy flowing through diode bridge rectifier **23** and capacitor **24**. The number of capacitors may be of a wide range, depending upon the amount of energy to be temporarily stored before being expelled or flash charged into recovery battery **29**. Timing belt **25** connects drive pulley **22** on timing shaft **21** to timing wheel **26**. Attached to timing wheel **26** is contact rotor **27**, a copper insulated switch that upon rotation, comes in contact with brushes on mechanical switch **28**. The means for counting the number of rotor revolutions may be a timing gear or a timing belt. Finally, the available energy derived from the back EMF that is stored in capacitor **24** is then discharged and stored in recovery battery **29**.

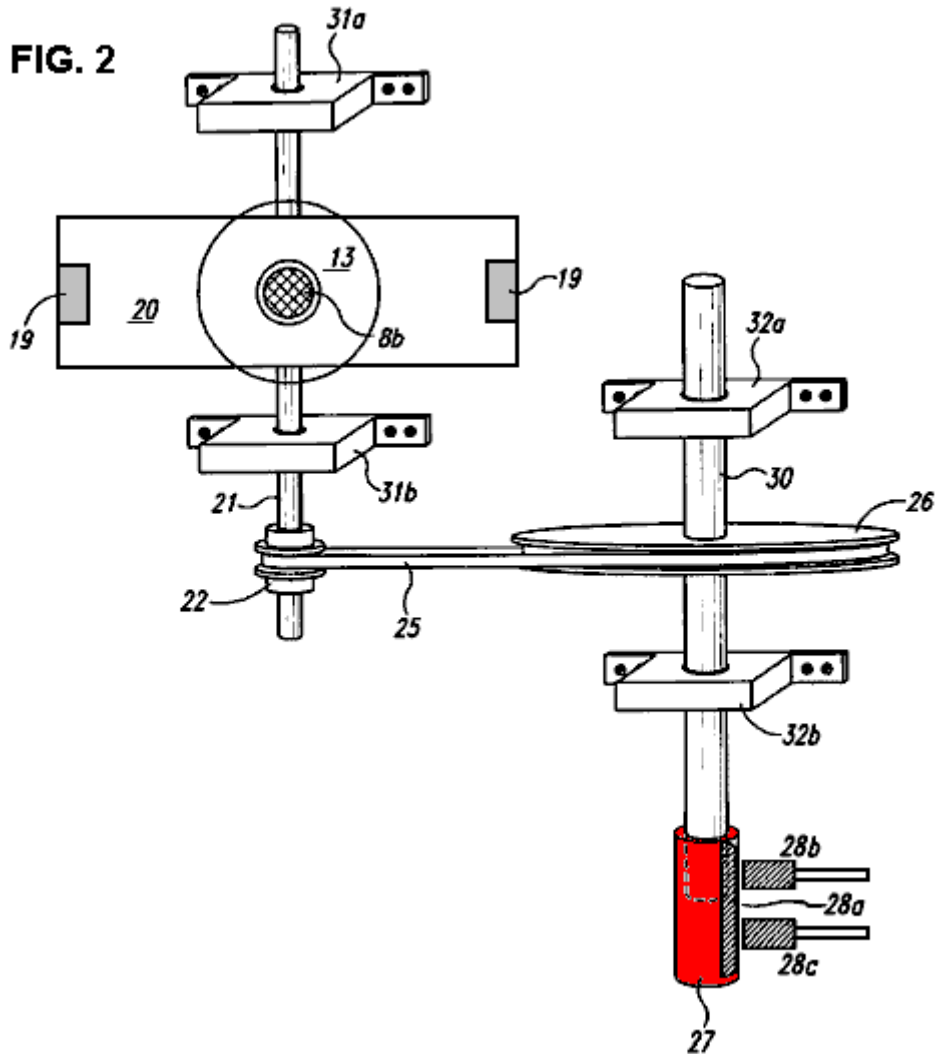
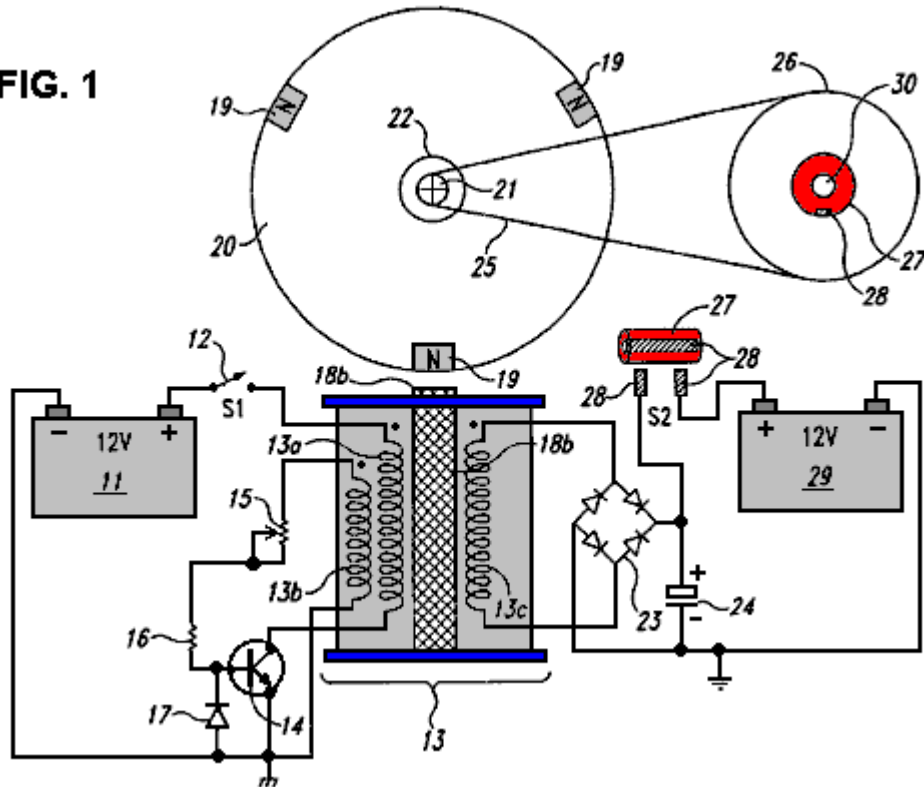

Fig.2 is a mechanical perspective top view of the monopole motor of the instant invention without electrical circuitry. Stator **18a** consists of coil **13**, which is comprised of three separate coil windings: power-coil winding **13a**, trigger-coil winding **13b** and recovery-coil winding **13c**. Pole piece **18b** is at the end of stator **18a**. As rotor **20**, (which is attached to rotor shaft **21**) rotates, each pole **19** respectively comes in a momentary monopole interface with pole piece **18b**. The polarity of pole piece **18b** is constant when electrically magnetised. Rotor shaft **21** has rotor shaft bearing blocks **31a,b** attached to it for stabilisation of rotor shaft **21**. Attached to rotor shaft **21** is drive pulley **22** with timing belt **25** engaged with it. Another means for timing may be a timing gear. Timing belt **25** engages with timing wheel **26** at its other end. Timing wheel **26** is attached to timing shaft **30**. Shaft **30** is stabilised with timing shaft bearing blocks **32a,b**. Attached to one end of timing shaft **30** is contact rotor **27** with brush **28a**, which, upon rotation of the timing shaft, comes into momentary contact with brushes **28b,c**.

Fig.3 is a block diagram detailing the circuitry of the monopole motor. Block **40** represents primary battery **11** with energy flowing to coil block **41**, which represents coil windings **13a,b,c**. From coil block **41** energy flows into three directions: to trigger-circuit block **42**, transistor-circuit block **43**, and rectifier-circuit block **44**. Energy flows from rectifier-block **44** to storage-capacitor block **45** with energy flowing from block **45** to both recovery-battery block **46** and rotor-switch block **47**.

Referring to **Fig.1**, the operation of the motor is described according to an embodiment of the invention. For purpose of explanation, assume that the rotor **20** is initially not moving, and one of the poles **19** is in the three o'clock position.

FIG. 1



First, the switch **12** is closed. Because the transistor **14** is off, no current flows through the winding **13a**.

Next, the motor is started by rotating the rotor **20**, say, in a clockwise direction. The rotor may be rotated by hand, or by a conventional motor-starting device or circuit (not shown).

As the rotor **20** rotates, the pole **19** moves from the three o'clock position towards the pole piece **18b** and generates a magnetic flux in the windings **13a, 13b** and **13c**. More specifically, the stator **18a** and the pole piece **18b** include a ferromagnetic material such as iron. Therefore, as the pole **19** moves nearer to the pole piece **18b**, it magnetises the pole piece **18b** to a polarity - South in this instance - that is opposite to the polarity of the pole **19** (which is North). This magnetisation of the pole piece **18b** generates a magnetic flux in the windings **13a-13c**. Furthermore, this magnetisation also causes a magnetic attraction between the pole **19** and the pole piece **18b**. This attraction pulls the pole **19** toward the pole piece **18b**, and thus reinforces the rotation of the rotor **20**.

The magnetic flux in the windings **13a-13c** generates voltages across their respective windings. More specifically, as the pole **19** rotates toward the pole piece **18b**, the magnetisation of the stator **18a** and the pole piece **18b**, and thus the magnetic flux in the windings **13a-13c**, increases. This increasing flux generates voltages across the windings **13a-13c** such that the dotted (top) end of each winding is more positive than the opposite end. These voltages are proportional to the rate at which the magnetic flux is increasing, and so, they are proportional to the velocity of the pole **19**.

At some point, the voltage across the winding **13b** becomes high enough to turn the transistor **14c** on. This turn-on, i.e., trigger, voltage depends on the combined serial resistance of the potentiometer **15** and the resistor **16**. The higher this combined resistance, the higher the trigger voltage, and vice-versa. Therefore, one can set the level of the trigger voltage by adjusting the potentiometer **15**.

In addition, depending on the level of voltage across the capacitor **24**, the voltage across the winding **13c** may be high enough to cause an energy recovery current to flow through the winding **13c**, the rectifier **23**, and the capacitor **24**. Thus, when the recovery current flows, the winding **13c** is converting magnetic energy from the rotating pole **19** into electrical energy, which is stored in the capacitor **24**.

Once turned on, the transistor **14** generates an opposing magnetic flux in the windings **13a-13c**. More specifically, the transistor **14** draws a current from the battery **11**, through the switch **12** and the winding **13b**. This current increases and generates an increasing magnetic flux that opposes the flux generated by the rotating pole **19**.

When the opposing magnetic flux exceeds the flux generated by the rotating pole **19**, the opposing flux reinforces the rotation of the rotor **20**. Specifically, when the opposing flux (which is generated by the increasing current

through winding **13a**) exceeds the flux generated by the pole **19**, the magnetisation of the pole piece **18** inverts to North pole. Therefore, the reverse-magnetic pole piece **18** repels the pole **19**, and thus imparts a rotating force to the rotor **20**. The pole piece **18** rotates the rotor **20** with maximum efficiency if the pole-piece magnetisation inverts to North when the centre of the pole **19** is aligned with the centre of the pole piece. Typically, the potentiometer **15** is adjusted to set the trigger voltage of the transistor **14** at a level which attains or approximates to this maximum efficiency.

The transistor **14** then turns off before the opposing flux can work against the rotation of the rotor **20**. Specifically, if the pole piece **18** remains magnetised to North pole, it will repel the next pole **19** in a direction (counterclockwise in this example) opposite to the rotational direction of the rotor **20**. Therefore, the motor turns transistor **14** off, and thus demagnetises the pole piece **18**, before this undesirable repulsion occurs. More specifically, when the opposing flux exceeds the flux generated by the pole **19**, the voltage across the winding **13b** reverses polarity such that the dotted end is less positive than the opposite end. The voltage across the winding **13b** decreases as the opposing flux increases. At some point, the voltage at the base of the transistor decreases to a level that turns transistor **14** off. This turn-off point depends on the combined resistance of potentiometer **15** and resistor **16** and the capacitance (not shown) at the transistor base. Therefore, potentiometer **15** can be adjusted, or other conventional techniques can be used to adjust the timing of this turn-off point.

The rectifier **23** and capacitor **24** recapture the energy that is released by the magnetic field (which energy would otherwise be lost) when the transistor **14** turns off. Specifically, turning transistor **14** off abruptly, cuts off the current flowing through winding **13a**. This generates voltage spikes across the windings **13a-13c** where the dotted ends are less positive than their respective opposite ends. These voltage spikes represent the energy released as the current-induced magnetisation of stator **18a** and pole piece **18b** collapses, and may have a magnitude of several hundred volts. But, as the voltage spike across the winding **13c** increases above the sum of the two diode drops of the rectifier **23**, it causes an energy-recovery current to flow through the rectifier **23** and the voltage across the capacitor **24** charge the capacitor **24**. Thus, a significant portion of the energy released upon collapse of the current-induced magnetic field is recaptured and stored as a voltage in the capacitor **24**. In addition, the diode **17** prevents damage to the transistor **14** by clamping the reverse base-emitter voltage caused by the voltage spike across the winding **13b**.

The recaptured energy can be used in a number of ways. For example, the energy can be used to charge a battery **29**. In one embodiment, the timing wheel **26** makes two revolutions for each revolution of the rotor **20**. The contact rotor **27** closes a switch **28**, and thus dumps the charge on the capacitor **24** into the battery **29**, once each revolution of the wheel **26**. Other energy-recapture devices and techniques may also be used. Rotor **20** may be stopped, either by applying a brake to it or by opening the switch **12**.

Other embodiments of the monopole motor are contemplated. For example, instead of remaining closed for the entire operation of the motor, the switch **12** may be a conventional optical switch or a Hall-effect switch that opens and closes automatically at the appropriate times. To increase the power of the motor, the number of stators **18a** and pole pieces **18b**, may be increased and/or the number of poles **19**. Furthermore, one can magnetise the stator **18a** and pole piece **18b** during the attraction of the pole **19** instead of or in addition to magnetising the stator and pole piece during the repulsion of the pole **19**.

Moreover, the stator **18a** may be omitted so that coil **13** becomes an air coil, or the stator **18a** and the pole piece **18b** may compose a permanent magnet. In addition, although the transistor **14** is described as being a bipolar transistor, a MOSFET transistor may also be used. Furthermore, the recaptured energy may be used to recharge the battery **11**. In addition, although described as rotating in a clockwise direction, the rotor **20** can rotate in a counterclockwise direction. Moreover, although described as attracting a rotor pole **19** when no current flows through winding **13a** and repelling the pole **19** when a current flows through winding **13a**, the pole piece **18b** may be constructed so that it attracts the pole **19** when a current flows through winding **13a** and repels the pole **19** when no current flows through winding **13a**.

In multiple stator/rotor systems, each individual stator may be energised one at a time or all of the stators may be energised simultaneously. Any number of stators and rotors may be incorporated into the design of such multiple stator/rotor monopole motor combinations. However, while there may be several stators per rotor, there can only be one rotor for a single stator. The number of stators and rotors that would comprise a particular motor is dependent upon the amount of power required in the form of watts. Any number of magnets, used in a monopole fashion, may comprise a single rotor. The number of magnets incorporated into a particular rotor is dependent upon the size of the rotor and power required of the motor. The desired size and horse power of the motor determines whether the stators will be in parallel or fired sequentially. Energy is made accessible through the capturing of available energy from the back EMF as a result of the unique circuitry and timing of the monopole motor. Individual motors may be connected in sequence with each motor having various combinations of stators and rotors or they may be connected in parallel. Each rotor may have any number of rotor magnets, all arranged without change of polarity. The number of stators for an individual motor may also be of a wide range.

One feature that distinguishes this motor from all others, is the use of monopole magnets in momentary apposition with the pole piece of the stator maintaining the same polarity when magnetised. In this particular embodiment, there are three magnets and one pole piece, the pole piece being an extension of a permanent-magnet stator. Finally, although the invention has been described with reference of particular means, materials and embodiments, it is to be understood that the invention is not limited to the particulars disclosed and extends to all equivalents within the scope of the claims.

CLAIMS

1. A back EMF monopole motor utilising a rotor wherein the magnets maintain a polarity when in apposition with a stator pole piece having the polarity, said motor to capture available back EMF energy for charging and storage in a recovery device, the motor comprising:
 - a. A means for producing initial energy;
 - b. A means for capturing energy in the form of back EMF, caused by a collapsing field in a coil comprised of multiple windings with a pole piece at one end of the stator of the coil, the pole piece having the correct polarity when magnetised and in aligned with the magnets of the rotor;
 - c. A means for rectifying the back EMF energy, comprising of a voltage bridge for transferring the back EMF energy to a capacitor for storage;
 - d. A means for discharging the stored voltage across a recovery battery; and
 - e. A means for counting the revolutions of the rotor.
2. The back EMF monopole motor of Claim 1, where a battery is used to provide the initial energy.
3. The back EMF monopole motor of claim 1, where the rotor revolutions are counted by a timing gear.
4. The back EMF monopole motor of claim 1, where the rotor revolutions are counted by a timing belt.
5. The back EMF monopole motor of claim 1, where the means for discharging collected energy comprises a rotating switching commutator which discharges the collected energy into a recovery battery, the commutator switch having the same polarity as the recovery battery.
6. A back EMF monopole motor utilising a rotor in which the rotor magnets maintain a polarity when aligned with a magnetised stator pole piece, suited to capturing available back EMF energy for charging and storage in a recovery device, the motor comprising:
 - a. A primary input battery and a means for switching the battery, namely, either a solid-state switching circuitry, a magnetic Reed switch, a commutator, an optical switch, or a Hall-effect switch;
 - b. A means for capturing energy in the form of back EMF, created by a collapsing field in a coil comprised of multiple windings and a pole piece at one end of the stator coil;
 - c. A means for rectifying the back EMF energy comprising a voltage bridge for transferring the energy to a capacitor for storage;
 - d. A means for discharging the stored voltage across a recovery battery, the means being a rotating contact rotor switch;
 - e. A means for counting the revolutions of the rotor via a timing gear or timing belt;
- f. A rotating switching commutator for switching the rotating contact rotor switch.

**DEVICE AND METHOD OF A BACK EMF PERMANENT
ELECTROMAGNETIC MOTOR GENERATOR**

ABSTRACT

This invention is a back EMF permanent electromagnetic motor generator and method using a regauging process for capturing available electromagnetic energy in the system. The device comprises a rotor with magnets of the same polarity; a timing wheel in apposition to a magnetic Hall-effect pickup switch semiconductor; and a stator comprised of two bars connected by a permanent magnet with magnetised pole pieces at one end of each bar. There are input and output coils created by wrapping each bar with a conducting material such as copper wire. Energy from the output coils is transferred to a recovery rectifier or diode. The magnets of the rotor, which is located on a shaft along with the timing wheel, are in apposition to the magnetised pole pieces of the two bars. The invention works through a process of regauging, that is, the flux fields created by the coils is collapsed because of a reversal of the magnetic field in the magnetised pole pieces thus allowing the capture of available back EMF energy. Additional available energy may be captured and used to re-energise the battery, and/or sent in another direction to be used for work. As an alternative, the available back EMF energy may be dissipated into the system.

BACKGROUND OF THE INVENTION

1. Field of the Invention

The invention relates generally to the capturing of electromagnetic energy using a method and device to create back EMF (electromagnetic force) and re-phasing of the back EMF to recycle and capture the available back EMF energy. Back EMF is also referred to as regauging and may be defined as energy created by the magnetic field from coils, and only from coils, and not from magnets.

2. Background Information and Related Art

Operation of a normal magnetic motor has the rotor pole attracting the stator pole, resulting in the generation of power from the magnets to the rotor and flywheel. During this phase, energy flows from the magnetics to the rotor/flywheel and is stored in the increased rotation. A rotor pole leaving a stator pole and creating a condition of drag-back results in power having to be put back into the magnetic section by the rotor and flywheel to forcibly overcome the drag-back. In a perfect, friction-free motor, the nett force field is therefore referred to as most conservative. In other words, a most conservative EMF motor has maximum efficiency. Without extra energy continually fed to the motor, no nett work can be done by the magnetic field, since half the time the magnetic field adds energy to the load (the rotor and flywheel) and the other half of the time it subtracts energy from the load (the rotor and flywheel). Therefore the total nett energy output is zero in any such rotary process without additional energy input. To use a present day magnetic motor, continuous energy must be fed to the motor to overcome drag-back and to power the motor and its load.

Present EMF motors and generators all use such conservative fields and therefore, have internal losses. Hence, it is necessary to continually input all of the energy that the motor outputs to the load, plus more energy to cover losses inside the motor itself. EMF motors are rated for efficiency and performance by how much energy input into the motor actually results in output energy to the load. Normally, the Coefficient of Performance (COP) rating is used as a measure of efficiency. The COP is the actual output energy going into the load and powering it, divided by the energy that must be input into the device with its load. COP is the power out into the load, divided by the power input into the motor/load combination. If there were zero internal losses in a motor, that "perfect" motor would have a coefficient of performance (COP) equal to 1.0. That is, all energy fed into the motor would be output by the motor directly into the load, and none of the input energy would be lost or dissipated in the motor itself.

In magnetic motor generators presently in use, however, due to friction and design flaws, there are always internal losses and inefficiencies. Some of the energy input into the motor is dissipated in these internal losses. As a consequence, the energy that gets to the load is always less than the input energy. So a standard motor operates with a COP of less than 1.0 which is expressed as $COP < 1.0$. An inefficient motor may have a COP of 0.4 or 0.45, while a specially designed, highly efficient motor may have a COP of 0.85.

The conservative field inside a motor itself can be divided into two phases. Producing a conservative field involves nett symmetry between the "power out" phase from the magnetics to the rotor/flywheel and the "power back in" phase from the rotor/flywheel back to the magnetics. That is, the two flows of energy (one from the

magnetics into the rotor and flywheel, and one from the rotor and flywheel back to the magnetics) are identical in magnitude but opposite in direction. Each phase alone is said to be "asymmetrical"; that is, it either has:

- 1) a nett energy flow out to the rotor/flywheel; or
- 2) a nett energy flow back into the magnetics from the rotor/flywheel.

In simplified terms, it is referred to as "power out" and "power back in" phases with respect to the motor magnetics. Hence, the two asymmetrical phases are:

- 1) the power-out phase; and
- 2) the "power back in" phase, with reference to the magnetics.

For the power-out phase, energy is derived from the EMF existing between the stator pole and incoming rotor pole in an attraction mode. In this phase, the rotary motion (angular momentum and kinetic energy) of the rotor and flywheel is increased. In short, power is added to the rotor/flywheel (and thus to the load) from the fields between stator pole and rotor pole (the electromagnetic aspects of the system).

For the "power back in" phase, energy must be fed back into the magnetics from the rotor and flywheel (and the load) to overcome the drag-back forces existing between stator pole and outgoing rotor pole. In this phase, energy is returned to the internal magnetic system from the rotary motion of the rotor and flywheel (the angular momentum, which is the rotational energy multiplied by time). As is well known in physics, a rotor/flywheel's angular momentum provides a convenient way to store energy with the spinning rotor/flywheel mass acting as an energy reservoir.

All present day conventional magnetic motors use various methods for overcoming, and partially reversing, back EMF. Back EMF is the out of phase return pulse from the coil and is also referred to as regauging. The back EMF is shorted out and the rotor is attracted back in, therefore eliminating back drag. This can be accomplished by pouring more energy in to overpower the back EMF, thereby producing a forward EMF in that region. The energy required for this method must be furnished by the operator.

The motor of the present invention uses only a small amount of energy to "trigger" a much larger input of available energy by supplying back EMF, thus increasing the potential energy of the system. It then utilises this excess potential energy to reduce or reverse back EMF, thereby increasing the efficiency of the motor and, therefore, the COP.

If the energy in phase 1 (the power-out phase) is increased by additional available energy in the electromagnetics themselves, then the energy in phase 1 can be made greater than the energy in phase 2 (the power-back-in phase) without the operator furnishing the energy utilised. This produces a non-conservative nett field. Nett power can then be taken from the rotating stator and flywheel, because the available energy transferred into the stator and flywheel by the additional effects, is transformed by the rotor/flywheel into additional angular momentum and stored as such. Angular momentum is conserved at all times; but now some of the angular momentum added to the flywheel is generated by additional effects in the electromagnetics rather than being provided by the operator.

Electrodynamists assume that the potential available energy of any system can be changed at will and without cost. This is back EMF and is well-known in physics. It is also routinely employed by electrodynamicists in the theoretical aspects. However, to simplify the mathematics, electrodynamicists will create a back EMF twice simultaneously, each back EMF being carefully selected so that the two available forces which are produced, are equal and opposite and cancel each other "symmetrically". This is referred to as "symmetrical back EMF". A symmetrical back EMF system cannot produce a $COP > 1.0$.

On the other hand, the motor of the present invention deliberately creates a back EMF itself and its potential energy only once at a time, thereby retaining each extra force for a period of time and applying it to increase the angular momentum and kinetic energy of the rotor and flywheel. Specifically, this back EMF energy with its nett force is deliberately applied in the motor of the present invention to overcome and even reverse the conventional drag-back (the back EMF). Hence less energy need be taken from the rotor and flywheel to overcome the reduced back EMF, and in the ideal case none is required since the back EMF has been overpowered and converted to forward EMF by the back EMF energy and force. In the motor of the present invention, the conventional back-drag section of the magnetics becomes a forward-EMF section and now adds energy to the rotor/flywheel instead of subtracting it. The important feature is that the operator only has to provide the small amount of energy necessary to trigger the back EMF, and does not have to furnish the much larger back EMF energy itself.

When the desired energy in phase 1 (the power out phase) is thus made greater than the undesired "drag-back" energy in phase 2, then part of the output power normally dragged back from the rotor and flywheel by the fields in phase 2 is not required. Hence, compared to a system without the special back EMF mechanisms, additional power is available from the rotor/flywheel. The rotor maintains additional angular momentum and kinetic energy, compared to a system which does not produce back EMF itself. Consequently, the excess angular momentum

retained by the rotor and flywheel can be utilised as additional shaft power to power an external load connected to the shaft.

A standard magnetic motor operates as the result of the motor being furnished with external energy input into the system by the operator to reduce phase 2 (power back into the magnetics from the rotor/flywheel) by any of several methods and mechanisms. The primary purpose of this external energy input into the system is to overcome the back EMF and also provide for the inevitable energy losses in the system. There is no input of energy separate from the operator input. Therefore, the COP of any standard magnetic motor is COP less than 1.0. The efficiency of a standard magnetic motor varies from less than 50% to a maximum of about 85%, and so has a COP<1.0. When nothing is done in the motor that will produce a reduction of the back EMF without the operator inputting all the energy for it, then for even a frictionless, ideal permanent magnet motor, the COP can never exceed 1.0.

Until the introduction of the motor of the present invention, it has been standard universal practice that the operator must furnish all energy used to reduce the back EMF, provide for the internal losses, and power the load. It is therefore a common belief by the scientific community that an ideal (loss-less) permanent magnet motor cannot exceed a COP of 1.0. That is true, so long as the operator himself must furnish all the energy. Furthermore, since real permanent magnetic motors have real internal losses, some of the input energy is always lost in the motor itself, and that lost energy is not available for powering the rotor/flywheel and load. Hence a real permanent magnetic motor of the conventional kind will always have a COP<1.0.

The common assumption that the COP of a motor is limited to less than 1.0 is not necessarily true, and that COP>1.0 is permitted without violating the laws of nature, physics, or thermodynamics. However, it can immediately be seen that any permanent magnet motor exhibiting a COP>1.0 must have some available energy input returning in the form of back EMF.

A problem relates to how back EMF energy can be obtained from a circuit's external environment for the specific task of reducing the back-drag EMF without the operator having to supply any input of that excess energy. In short, the ultimate challenge is to find a way to cause the system to:

- 1) become an open dissipative system, that is, a system receiving available excess energy from its environment, in other words, from an external source; and
- 2) use that available excess energy to reduce the drag-back EMF between stator and rotor poles as the rotor pole is leaving the stator pole.

If this objective can be accomplished, the system will be removed from thermodynamic equilibrium. Instead, it will be converted to a system out-of-thermodynamic equilibrium. Such a system is not obliged to obey classical equilibrium thermodynamics.

Instead, an out-of-equilibrium thermodynamic system must obey the thermodynamics of open systems far from the established and well-known parameters of thermodynamic equilibrium. As is well known in the physics of thermodynamics, such open systems can permissibly:

- 1) self-order;
- 2) self-oscillate;
- 3) output more back EMF energy than energy input by the operator (the available excess back EMF energy is received from an external source and some energy is input by the operator as well);
- 4) power itself as well as its loads and losses simultaneously (in that case, all the energy is received from the available external source and there is no input energy from the operator); and
- 5) exhibit negative entropy, that is, produce an increase of energy that is available in the system, and that is independent of the energy put into the system by the operator.

As a definition, entropy roughly corresponds to the energy of a system that has become unavailable for use. Negative entropy corresponds to additional energy of a system that has become available for use.

In the back EMF permanent magnet electromagnetic motor generator of the present invention, several known processes and methods are utilised which allow the invention to operate periodically as an open dissipative system (receiving available excess energy from back EMF) far from thermodynamic equilibrium, whereby it produces and receives its excess energy from a known external source.

A method is utilised to temporarily produce a much larger source of available external energy around an energised coil. Then the unique design features of this new motor provides a method and mechanism that can immediately produce a second increase in that energy, concurrently as the energy flow is reversed. Therefore, the motor is capable of producing two asymmetrical back EMFs, one after the other, of the energy within a single coil, which dramatically increases the energy available and causes that available excess energy to then enter the circuit as an impulse, being collected and utilised.

The present motor utilises this available excess back EMF energy to overcome and even reverse the back-drag EMF between stator pole and rotor pole, while furnishing only a small trigger pulse of energy necessary to control and activate the direction of the back EMF energy flow.

By using a number of such dual asymmetrical self back EMFs for every revolution of the rotor, the rotor and flywheel collectively focus all the excess impulsive inputs into increased angular momentum (expressed as energy multiplied by time), shaft torque, and shaft power.

Further, some of the excess energy deliberately generated in the coil by the utilisation of the dual process manifests itself in the form of excess electrical energy in the circuit and is utilised to power electrical loads, e.g., a lamp, fan, motor, or other electrical devices. The remainder of the excess energy generated in the coil can be used to power the rotor and flywheel, with the rotor/flywheel also furnishing shaft horsepower for powering mechanical loads.

This new and unique motor utilises a means to furnish the relatively small amount of energy to initiate the impulsive asymmetrical self back EMF actions. Then part of the available excess electrical power drawn off from the back EMFs is utilised to recharge the battery with dramatically increased over voltage pulses.

The unique design features of this motor utilise both north and south magnetic poles of each rotor and stator magnet. Therefore, the number of impulsive self back EMFs in a single rotation of the rotor is doubled. Advanced designs increase the number of self back EMFs in a single rotor rotation with the result that there is an increase in the number of impulses per rotation which increase the power output of this new motor.

The sharp voltage pulse produced in the coil of this new motor by the rapidly collapsing field in the back EMF coil is connected to a battery in charge mode and to an external electrical load. The nett result is that the coil asymmetrically creates back EMF itself in a manner adding available energy and impulse to the circuit. The excess available energy collected in the coil is used to reverse the back-EMF phase of the stator-rotor fields to a forward EMF condition, and through an impulse, adding acceleration and angular momentum to the rotor and flywheel. At the same time, a part of the excess energy collected in the coil is used to power electrical loads such as charging a battery and operating a lamp or such other device.

It is well known that changing the voltage alone, creates a back EMF and requires no work. This is because to change the potential energy does not require changing the form of that potential energy, but only its magnitude. Strictly speaking, work is the changing of the form of energy. Therefore, as long as the form of the potential energy is not changed, the magnitude can be changed without having to perform work in the process. The motor of the present invention takes advantage of this permissible operation to create back EMF asymmetrically, and thereby change its own usable available potential energy.

In an electric power system, the potential (voltage) is changed by inputting energy to do work on the internal charges of the generator or battery. This potential energy is expended within the generator (or battery) to force the internal charges apart, forming a source dipole. Then the external closed circuit system connected to that source dipole ineptly pumps the spent electrons in the ground line back through the back EMF of the source dipole, thereby scattering the charges and killing the dipole. This shuts off the energy flow from the source dipole to the external circuit. As a consequence of that conventional method, it is a requirement to input and replace additional energy to again restore the dipole. The circuits currently utilised in most electrical generators have been designed to keep on destroying the energy flow by continually scattering all of the dipole charges and terminating the dipole. Therefore, it is necessary to keep on inputting energy to the generator to keep restoring its source dipole.

An investigation of particle physics is required to see what furnishes the energy to the external circuit. Since neither a battery nor a generator furnishes energy to the external circuit, but only furnishes energy to form the source dipole, a better understanding of the electric power principle is required to fully understand how this new motor functions. A typical battery uses its stored chemical energy to form the source dipole. A generator utilises its input shaft energy of rotation to generate an internal magnetic field in which the positive charges are forced to move in one direction and the negative charges in the reverse direction, thereby forming the source dipole. In other words, the energy input into the generator does nothing except form the source dipole. None of the input energy goes to the external circuit. If increased current is drawn into the external load, there also is increased spent electron flow being rammed back through the source dipole, destroying it faster. Therefore, dipole-restoring-energy has to be inputted faster. The chemical energy of the battery also is expended only to separate its internal charges and form its source dipole. Again, if increased current and power is drawn into the external load, there is increased spent electron flow being rammed back through the source dipole, destroying it faster. This results in a depletion of the battery's stored energy faster, by forcing it to have to keep restoring the dipole faster.

Once the generator or battery source dipole is formed (the dipole is attached also to the external circuit), it is well known in particle physics that the dipole (same as any charge) is a broken symmetry in the vacuum energy flux.

By definition, this means that the source dipole extracts and orders part of that energy received from its vacuum interaction, and pours that energy out as the energy flowing through all space surrounding the external conductors in the attached circuit. Most of this enormous energy flow surging through space surrounding the external circuit does not strike the circuit at all, and does not get intercepted or utilised. Neither is it diverted into the circuit to power the electrons, but passes on out into space and is just "wasted". Only a small "sheath" of the energy flow along the surface of the conductors strikes the surface charges in those conductors and is thereby diverted into the circuit to power the electrons. Standard texts show the huge available but wasted energy flow component, but only calculate the small portion of the energy flow that strikes the circuit, is caught by it, and is utilised to power it.

In a typical circuit, the huge available but "wasted" component of the energy flow is about 10 to the power 13 times as large as the small component intercepted by the surface charges and diverted into the circuit to power it. Hence, around every circuit and circuit element such as a coil, there exists a huge non-intercepted, non-diverged energy flow that is far greater than the small energy flow being diverted and used by the circuit or element.

Thus there exists an enormous untapped energy flow immediately surrounding every EMF power circuit, from which available excess energy can be intercepted and collected by the circuit, if respective non-linear actions are initiated that sharply affect and increase the reaction cross section of the circuit (i.e., its ability to intercept this available but usually wasted energy flow).

The method in which the motor of the present invention alters the reaction cross section of the coils in the circuit, is by a novel use, which momentarily changes the reaction cross section of the coil in which it is invoked. Thus, by this new motor using only a small amount of current in the form of a triggering pulse, it is able to evoke and control the immediate change of the coil's reaction cross section to this normally wasted energy flow component. As a result, the motor captures and directs some of this usually wasted environmental energy, collecting the available excess energy in the coil and then releasing it for use in the motor. By timing and switching, the innovative gate design in this new motor directs the available excess energy so that it overcomes and reverses the return EMF of the rotor-stator pole combination during what would normally be the back EMF and demonstrates the creation of the second back EMF of the system. Now instead of an "equal retardation" force being produced in the back EMF region, a forward EMF is produced that is additive to the rotor/flywheel energy and not subtractive. In short, it further accelerates the rotor/flywheel.

This results in a non-conservative magnetic field along the rotor's path. The line integral of the field around that path (i.e., the nett work on the rotor/flywheel to increase its energy and angular momentum) is not zero but a significant amount. Hence, the creation of an asymmetrical back EMF impulse magnetic motor:

- 1) takes its available excess energy from a known external source, the huge usually non-intercepted portion of the energy flow around the coil;
- 2) further increases the source dipolarity by this back EMF energy; and
- 3) produces available excess energy flow directly from the source dipole's increased broken symmetry in its fierce energy exchange with the local vacuum.

No laws of physics or thermodynamics are violated in the method and device of the present invention, and conservation of energy rigorously applies at all times. Nonetheless, by operating as an open dissipative system not in thermodynamic equilibrium with the active vacuum, the system can permissibly receive available excess energy from a known environmental source and output more energy to a load than must be input by the operator alone. As an open system not in thermodynamic equilibrium, this new and unique motor can tap in to back EMF to energise itself, loads and losses simultaneously, fully complying with known laws of physics and thermodynamics.

A search of prior art failed to reveal any devices that recycle available energy from back EMF of a permanent electromagnetic motor generator as described in the present invention. However, the following prior art US patents were reviewed:

1. No. 5,532,532 to DeVault, et al., Hermetically Sealed Super-conducting Magnet Motor.
2. No. 5,508,575 to Elrod, Jr., Direct Drive Servovalve Having Magnetically Loaded Bearing.
3. No. 5,451,825 to Strohm, Voltage Homopolar Machine.
4. No. 5,371,426 to Nagate et al., Rotor For Brushless Motor.
5. No. 5,369,325 to Nagate et al., Rotor For Brushless Electromotor And Method For Making Same.
6. No. 5,356,534 to Zimmermann, deceased et al., Magnetic-Field Amplifier.
7. No. 5,350,958 to Ohnishi, Super-conducting Rotating Machine, A Super-conducting Coil, And A Super-conducting Generator For Use In A Lighting Equipment Using Solar Energy.
8. No. 5,334,894 to Nakagawa, Rotary Pulse Motor.
9. No. 5,177,054 to Lloyd, et al., Flux Trapped Superconductor Motor and Method.
10. No. 5,130,595 to Arora, Multiple Magnetic Paths Pulse Machine.
11. No. 4,980,595 to Arora, Multiple Magnetics Paths Machine.
12. No. 4,972,112 to Kim, Brushless D.C. Motor.

13. No. 4,916,346 to Kliman, Composite Rotor Lamination For Use In Reluctance Homopolar, And Permanent Magnet Machines.
14. No. 4,761,590 to Kaszman, Electric Motor.
15. No. 4,536,230 to Landa, et al., Anisotropic Permanent Magnets.
16. No. Re. 31,950 to Binns, Alternating Current Generators And Motors.
17. No. 4,488,075 to DeCesare, Alternator With Rotor Axial Flux Excitation.
18. No. 4,433,260 to Weisbord et al., Hysteresis Synchronous Motor Utilizing Polarized Rotor.
19. No. 4,429,263 to Muller, Low Magnetic Leakage Flux Brushless Pulse Controlled D-C Motor.
20. No. 4,423,343 to Field, II, Synchronous Motor System.
21. No. 4,417,167 to Ishii et al., DC Brushless Motor.
22. No. 4,265,754 to Menold, Water Treating Apparatus and Methods.
23. No. 4,265,746 to Zimmermann, Sr. et al. Water Treating Apparatus and Methods.
24. No. 4,222,021 to Bunker, Jr., Magnetic Apparatus Appearing To Possess a Single Pole.
25. No. 2,974,981 to Vervest et al., Arrester For Iron Particles.
26. No. 2,613,246 to Spodig, Magnetic System.
27. No. 2,560,260 to Sturtevant et al., Temperature Compensated Magnetic Suspension.

SUMMARY OF THE INVENTION

The device and method of the present invention is a new permanent electromagnetic motor generator that recycles back EMF energy (regauging) thus allowing the motor to produce an energy level of COP = 0.98, more or less, depending upon configuration, circuitry, switching elements and the number and size of stators, rotors and coils that comprise the motor. The rotor is fixed between two pole pieces of the stator. The motor generator is initially energised from a small starter battery means, analogous to a spark plug, that sends a small amount of energy to the motor, thus stimulating a rotating motion from the rotor. As the rotor rotates, energy is captured from the surrounding electromagnetic field containing an asymmetrical pulse wave of back EMF. The energy produced and captured can be directed in one of several directions, including returning energy to the initial starter battery, rotating a shaft for work and/or sending a current to energise a fan, light bulb or other such device.

BRIEF DESCRIPTION OF THE DRAWINGS

FIG.1 is the top view of a back EMF permanent electromagnetic motor generator with a single stator and a single rotor.

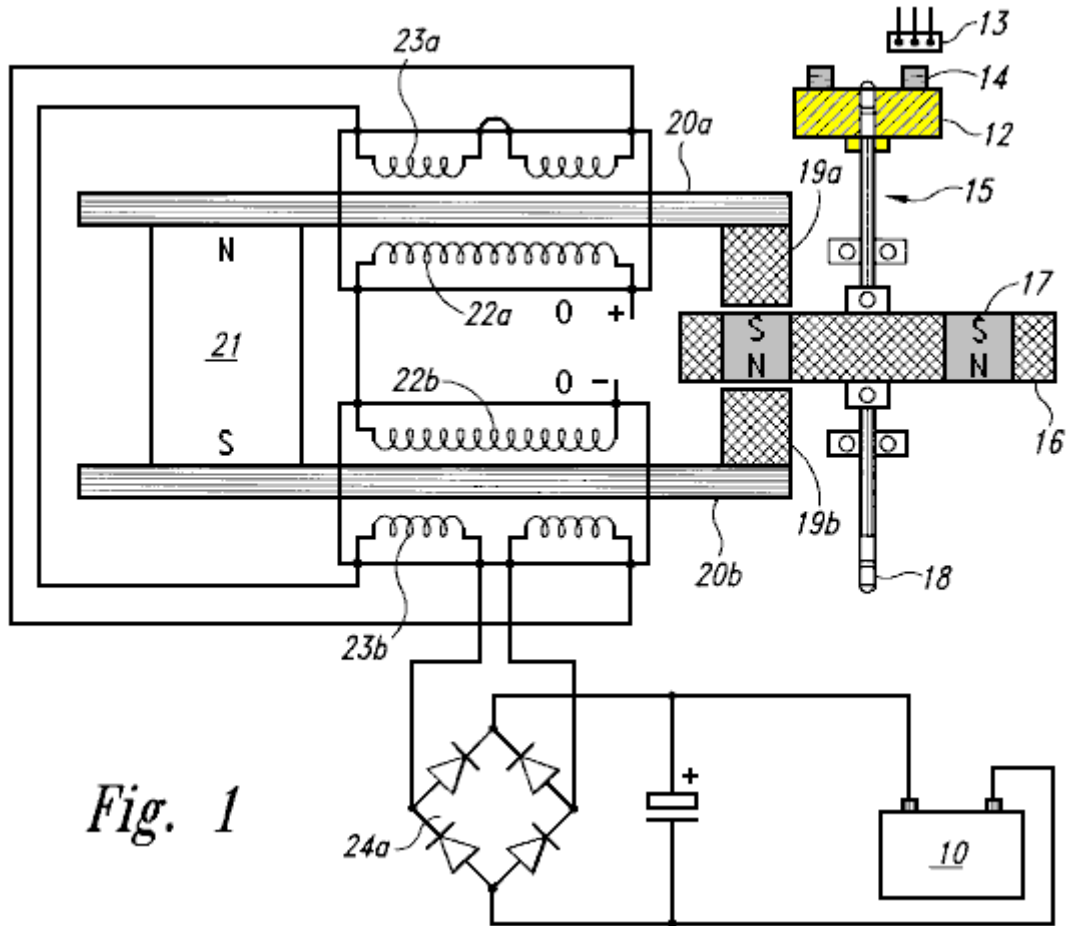

Fig.1a is a side view of a timing wheel and magnetic Hall-effect sensor of the back EMF motor generator.

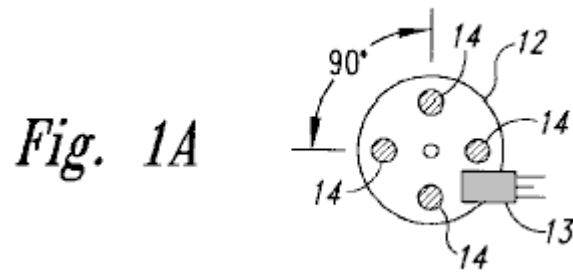

Fig.1b is a side view of the rotor of the back EMF motor generator.

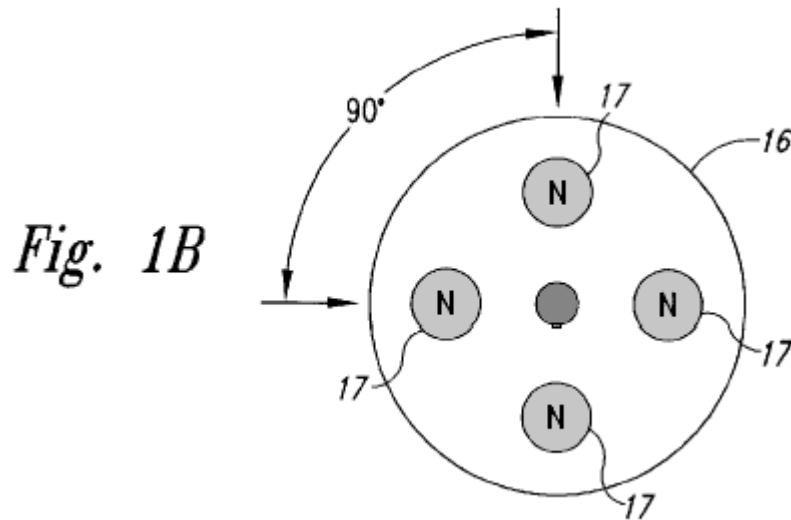

Fig.2 is a schematic drawing incorporating circuitry for the back EMF motor generator.

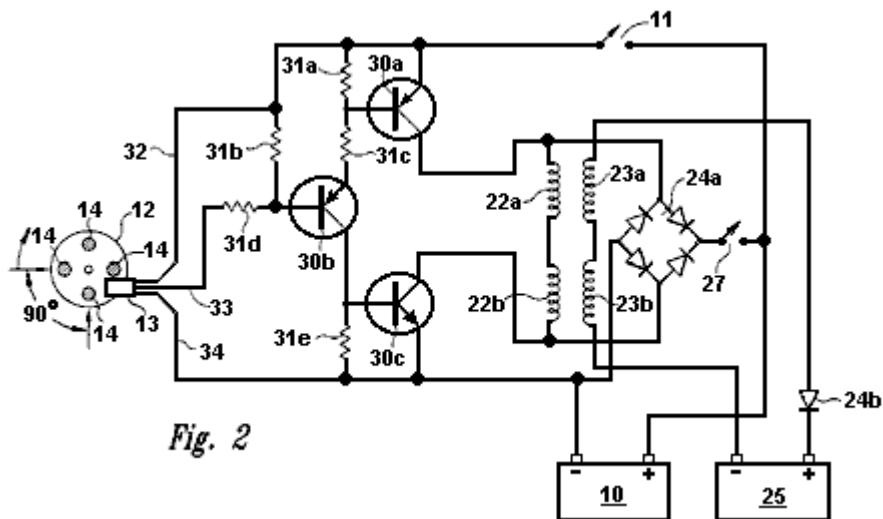
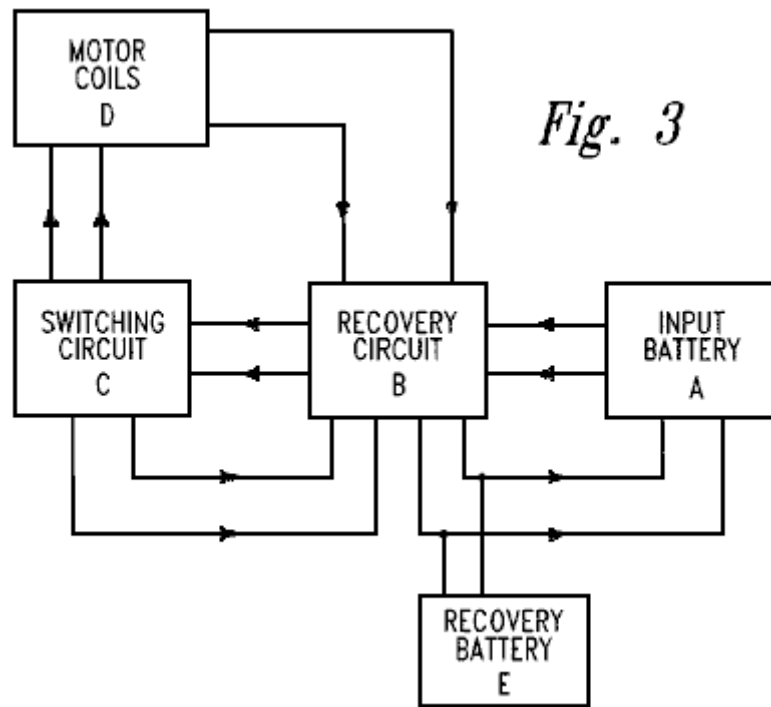

Fig.3 is a box diagram showing the relationships of the back EMF motor generator circuitry.



DETAILED DESCRIPTION OF THE INVENTION

The present invention is a device and method for creating a back EMF permanent electromagnetic motor generator. As described in the Background Information, this new motor generator conforms to all applicable electrodynamic laws of physics and is in harmony with the law of the conservation of energy, the laws of electromagnetism and other related natural laws.

The back EMF permanent electromagnetic motor generator is comprised of a combination of electrical, material and magnetic elements, arranged to capture available electromagnetic energy (back EMF) in a recovery rectifier or single diode from output coils. The capturing of back EMF energy is also known as 'recharging'. As an arbitrary starting point in describing this invention, an input battery, as a means of energy, sends power through a power on-off switch and then to a timing mechanism, such as a magnetic timing switch (a semiconductor Hall-effect magnetic pickup switch) which is triggered by a magnet on a timing wheel. The timing wheel may contain any number of magnets (i.e. one or more), with the South poles facing outwards and aligned with the Hall-effect pickup switch.

The timing wheel is mounted at the end of a shaft which is located along the centreline of a rotor, which in turn, may contain any number of magnets (i.e. two or more). The rotor magnets are arranged so that they have the same polarity and are equidistant from each other. The shaft has the timing wheel mounted at one end, the rotor, and then some means for performing work, such as a power take off at the opposite end. However, there are other embodiments in which the position of the rotor, timing wheel and power take-off have other configurations. The rotor is mounted on a platform or housing which is fixed in a stationary position within a stator.

The stator is comprised of a permanent magnet connected to a means for conducting electromagnetic energy such as two parallel bars, each bar having a magnetised pole piece at one end. The conduction material of the bar may be ferrous, powdered iron, silicon steel, stainless magnetic steel, laminations of conductive material or any other magnetic conductive material. Each bar has an input coil placed around it. The coil may be constructed from copper, aluminium or any other suitable conductive material. The primary or input coil is connected to the switching circuit. A second coil on top of the input coil becomes a secondary or output coil. The secondary or output coil is connected to the recovery circuit. The rotor is located symmetrically between the pole pieces of the bars of the stator and it contains a series of magnets all having the same polarity, North or South, with each magnet in the rotor being in aligned with the pole piece as the rotor rotates.

When the rotor is energised from the battery of the switching circuit, there is an initial magnetic field that is instantly overcome as the magnetised pole pieces align with the rotor magnets. As the rotor begins to move, increasing electromagnetic energy is produced as a result of flux gating from the aligned magnets of the rotor and pole pieces. The coils surrounding the bars "buck" the permanent magnet connecting the bars. This is known as the "buck boosting" principle. When the permanent magnet is bucked by the coils, it reverses the polarity of the pole pieces which are aligned with the rotor magnets causing the rotor to increase its rate of rotation. The energy

available from the fields that are collapsing in the primary and secondary coils, (which creates the back EMF within the system), is now in non-equilibrium. Energy can now be put back into the system via the switching circuitry. Available energy captured from the back EMF, may be applied in different directions, including re-energising the input battery, storage in a capacitor, conversion by a recovery rectifier to be stored in the input battery, a capacitor or a secondary or recovery battery. Recovery rectifiers are used to convert this AC to DC. Available energy may be used to energise an electric bulb, fan or any other uses.

The shaft in the centre of the rotor can transfer energy in the form of work through a power take-off. The power take-off may be connected to any number of secondary shafts, wheels, gears and belts to increase or reduce torque.

This is a description of the basic invention, however, there are an innumerable number of combinations and embodiments of stators, rotors, Hall-effect magnetic pickup switches, coils, recovery rectifiers and electronic connecting modes that may be combined on a single shaft or several shafts connected in various combinations and sequences, and of various sizes. There may be any number of stators to one rotor, (however, there can be only one active rotor if there is a single stator). The number of Hall-effect pickup switches may vary, for example, in the case of multiple stators of high resistant coils, the coils may be parallel to form a low resistant coil so that one Hall-effect pickup with one circuit may fire all of the stators at the same time. The number of magnets in both the timing wheel and the rotor may also vary in number as well as the size and strength of the magnets. Any type of magnet may be used. The number of turns on both the input and output coils on each conducting bar may also vary in number and in conductive material.

The motor generator, as shown in **Fig.1**, a top perspective view of a single stator, single rotor back EMF motor and is comprised of a means of providing energy, such as input battery **10** connected to power switch **11** (shown in **Fig.2**) and Hall-effect magnetic pickup switch **13**. Magnetic pickup **13** interfaces with timing wheel **12** to form a timing switch. Timing wheel **12** contains four magnets **14** with the South pole of each said magnet facing outward towards magnetic pickup **13**. Timing wheel **12** is fixed at one end of shaft **15**. Located on shaft **15** is rotor **16**. Rotor **16** can be of any realistic size, and in this example the rotor contains four rotor magnets **17**. The rotor magnets **17** are arranged so all have the same polarity.

Opposite timing wheel **12** on shaft **15** is a means for performing work, such as a power take-off **18**. Rotor **16** is mounted in a fixed position with rotor magnets **17** in aligned with the magnetised pole pieces **19a** and **19b**. Each pole piece **19a** and **19b** is connected to iron bars **20a** and **20b**. These Iron bars are connected by a permanent magnet **21**. Wire is wrapped around iron bars **20a** and **20b** to form input coils **22a** and **22b**. Superimposed upon input coils **22a** and **22b** are output coils **23a** and **23b**. These output coils are connected to full wave bridge first recovery rectifier **24a** which then connects to battery **10**.

Fig.1a is a side view of the back EMF Motor Generator timing wheel **12** with Hall-effect magnetic pickup **13** positioned to be triggered by each of the four magnets **14** in turn as timing wheel **12** rotates. The magnets **14** have their South poles facing outward and they are spaced evenly with a 90 degree angular separation.

Fig.1b is a side view of rotor **16** with four rotor magnets **17** with 90 degree angular separation from each other and having the same polarity.

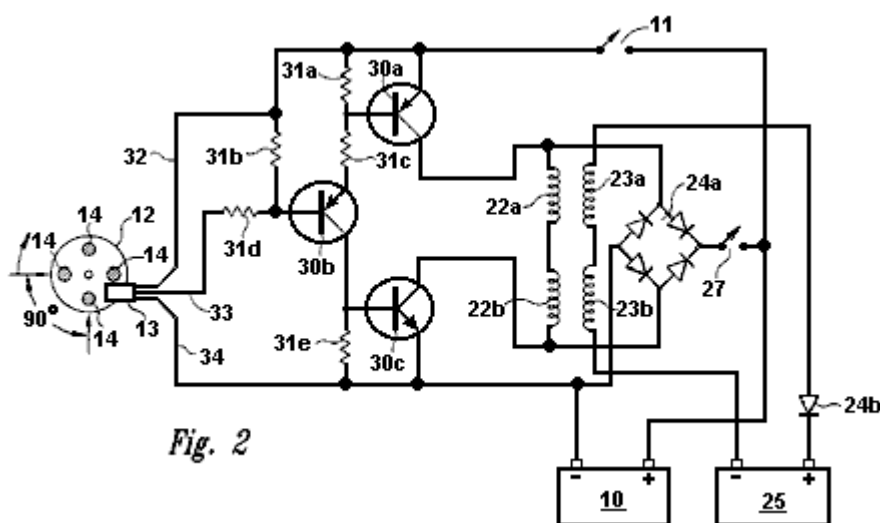

Fig.2 is a schematic diagram of the motor generator circuitry showing input coil connections from input battery **10** through power switch **11**, transistors **30a,b,c** resistors **31a-e**, through power supply lead **32** ("VCC+") and to magnetic pickup **13**. Magnetic pickup **13** is in aligned with timing wheel magnets **14** located on timing wheel **12**.

Collector lead **33** and ground lead **34** carry the signals from magnetic pickup **13**. When current is reversed, it flows through resistor **31e** and transistor **30c** to input battery **10**. Input coils **22a,b** send power to full wave bridge first recovery rectifier **24a** which then sends power through switch recovery **27** back into the system, and/or to the input battery **10**. Output coils **23a** and **23b** send power through single diode second recovery rectifier **24b** to recovery battery **25**.

In this particular embodiment, the value and type number of the components are as follows:

Hall-effect magnetic pickup switch **13** is a No. 3020;

Transistor **30a** is a 2N2955;

Transistor **30b** is an **MPS8599**;

Transistor **30c** is a 2N3055;

Resistors **31a** and **31b** are 470 ohms

Resistor **31b** is 2.2 K ohms

Resistor **31c** is 220 ohms

Resistor **31d** is 1 K ohms

Recovery rectifier **24a** is a 10 Amp, 400 volts bridge rectifier.

Fig.3 is a box diagram showing the flow of voltage from input battery **A**, through recovery circuit **B**, switching circuit **C** and motor coils **D**. Motor coils **D** send available back EMF energy through recovery circuit **B**, and then on to recovery battery **E** and input battery **A**. Available back EMF energy can also flow from switching circuit **C** to recovery circuit **B**.

In multiple stator/rotor systems, each individual stator may be energised one at a time or all of the stators may be energised simultaneously. Any number of stators and rotors may be incorporated into the design of such multiple stator/rotor motor generator combinations. However, while there may be several stators per rotor, there can only be one rotor for a single stator. The number of stators and rotors that would comprise a particular motor generator is dependent upon the amount of power required in the form of watts. The desired size and horsepower of the motor determines whether the stators will be in parallel or fired sequentially by the magnetic Hall-effect pickup or pickups. The number of magnets incorporated into a particular rotor is dependent upon the size of the rotor and power required of the motor generator. In a multiple stator/rotor motor generator, the timing wheel may have one or more magnets, but must have one magnet Hall-effect pickup for each stator if the stators are not arranged in parallel. The back EMF energy is made available through the reversing of the polarity of the magnetised pole pieces thus collapsing the field around the coils and reversing the flow of energy to the recovery diodes, which are capturing the back EMF.

Individual motors may be connected in sequence, with each motor having various combinations of stators and rotors, or they may be connected in parallel. Each rotor may have any number of magnets ranging from a minimum of 2 to maximum of 60. The number of stators for an individual motor may range from 1 to 60 with the number of conducting bars ranging from 2 to 120.

What distinguishes this motor generator from all others is the presence of a permanent magnet connecting the two conducting bars which transfer magnetic energy through the pole pieces to the rotor, thereby attracting the rotor between the pole pieces. With the rotor attracted in between the two pole pieces, the coils switch the polarity of the magnetic field of the pole pieces so that the rotor is repelled out. Therefore there is no current and voltage being used to attract the rotor. The only current being used is the repulsion of the rotor between the two conductive bar pole pieces thereby requiring only a small amount of current to repel the rotor. This is known as 'a regauging system' and allows the capturing of available back EMF energy.

Finally, although the invention has been described with reference of particular means, materials and embodiments, it is to be understood that the invention is not limited to the particulars disclosed and extends to all equivalents within the scope of the claims.

**DEVICE AND METHOD FOR PULSE-CHARGING A BATTERY
AND FOR DRIVING OTHER DEVICES WITH A PULSE**

This is a slightly reworded copy of this patent application which shows a method of pulse-charging a battery bank or powering a heater and/or a motor. John Bedini is an intuitive genius with very considerable practical ability, so any information coming from him should be considered most carefully. At the end of this document there is some additional information not found in the patent.

ABSTRACT

This two-phase solid-state battery charger can receive input energy from a variety of sources including AC current, a battery, a DC generator, a DC-to-DC inverter, solar cells or any other compatible source of input energy. Phase 1 is the charging phase and Phase 2 is the discharge phase, where a signal, or current, passes through a dual timing switch which independently controls two channels, thus producing the two phases.

The dual timing switch is controlled by a logic chip, or pulse width modulator. A potential charge is allowed to build up in a capacitor bank. The capacitor bank is then disconnected from the energy input source and then a high voltage pulse is fed into the battery which is there to receive the charge. The momentary disconnection of the capacitor from the input energy source allows a free-floating potential charge in the capacitor. Once the capacitor has completed discharging the potential charge into the battery, the capacitor disconnects from the charging battery and re-connects to the energy source, thus completing the two-phase cycle.

TECHNICAL FIELD

This invention relates generally to a battery pulse-charger using a solid-state device and method where the current going to the battery is not constant. The signal or current is momentarily switch-interrupted as it flows through either the first channel, (the charging phase), or the second channel, (the discharging phase). This two-phase cycle alternates the signal in the two channels thereby allowing a potential charge in a capacitor to disconnect from its power source an instant before the capacitor discharges its stored potential energy into a battery set up to receive the capacitor's stored energy. The capacitor is then disconnected from the battery and re-connected to the power source upon completion of the discharge phase, thereby completing the charge-discharge cycle. The battery pulse-charger can also drive devices, such as a motor and a heating element, with pulses.

BACKGROUND AND PRIOR ART

Present day battery chargers use a constant charge current in their operation with no momentary disconnection of the signal or current as it flows either: (1) from a primary energy source to the charger; or (2) from the charger itself into a battery for receiving the charge. Some chargers are regulated to a constant current by any of several methods, while others are constant and are not regulated. There are no battery chargers currently in the art or available wherein there is a momentary signal or current disconnection between the primary energy source and the charger capacitors an instant before the capacitors discharge the stored potential energy into a battery receiving the pulse charge. Nor are there any chargers in the art that disconnect the charger from the battery receiving the charge when the charger capacitors receive energy from the primary source. The momentary current interruption allows the battery a short "rest period" and requires less energy from the primary energy source while putting more energy into the battery receiving the charge while requiring a shorter period of time to do it.

SUMMARY OF THE INVENTION

One aspect of the invention relates to a solid-state device and method for creating a pulse current to pulse-charge a battery or a bank of batteries in which a new and unique method is used to increase and preserve, for a longer period of time, the energy stored in the battery, as compared to constant-current battery chargers. The device uses a timed pulse to create a DC pulse waveform to be discharged into the battery receiving the charge.

One embodiment of the Invention uses a means for dual switching such as a pulse-width modulator (PWM), for example, a logic chip SG3524N PWM, and a means for optical coupling to a bank of high-energy capacitors to

store a timed initial pulse charge. This is the charge phase, or phase 1. The charged capacitor bank then discharges the stored high energy into the battery receiving the charge in timed pulses. Just prior to discharging the stored energy into the battery, the capacitor bank is momentarily disconnected from the power source, thus completing the charge phase, and thereby leaving the capacitor bank as a free-floating potential charge disconnected from the primary energy source to then be discharged into the battery. The transfer of energy from the capacitor bank to the battery completes the discharge phase, or phase 2. The two-phase cycle now repeats itself.

This embodiment of the battery pulse-charger works by transferring energy from a source, such as an AC source, to an unfiltered DC source of high voltage to be stored in a capacitor or a capacitor bank. A switching regulator is set to a timed pulse, for example, a one second pulse that is 180 degrees out of phase for each set of switching functions. The first function is to build the charge in the capacitor bank from the primary energy source; the second function is to disconnect the power source from the capacitor bank; the third function is to discharge the stored high voltage to the battery with a high voltage spike in a timed pulse, for example, a one second pulse; and the fourth function is to re-connect the capacitor bank to the primary energy source.

The device operates through a two-channel on/off switching mechanism or a gauging/re-gauging function wherein the charger is disconnected from its primary energy source an instant before the pulse-charger discharges the high-energy pulse into the battery to be charged. As the primary charging switch closes, the secondary discharging switch opens, and vice-versa in timed pulses to complete the two phase cycle.

The means for a power supply is varied with several options available as the primary energy source. For example, primary input energy may come from an AC source connected into the proper voltage (transformer); from an AC generator; from a primary input battery; from solar cells; from a DC-to-DC inverter; or from any other adaptable source of energy. If a transformer is the source of primary input energy, then it can be a standard rectifying transformer used in power supply applications or any other transformer applicable to the desired function. For example, it can be a 120-volt to 45-volt AC step-down transformer, and the rectifier can be a full-wave bridge of 200 volts at 20 amps, which is unfiltered when connected to the output of the transformer. The positive output terminal of the bridge rectifier is connected to the drains of the parallel connected field-effect transistors, and the negative terminal is connected to the negative side of the capacitor bank.

The Field Effect Transistor (FET) switches can be IRF260 FETs, or any other FET needed to accomplish this function. All the FETs are connected in parallel to achieve the proper current handling capacity for the pulses. Each FET may be connected through a 7-watt, 0.05-ohm resistor with a common bus connection at the source. All the FET gates may be connected through a 240-ohm resistor to a common bus. There may also be a 2 K-ohm resistor wired between the FET gates and the drain bus.

A transistor, for example an MJE15024, can be used as a driver for the gates, driving the bus, and in turn, an optical coupler powers the driver transistor through the first channel. A first charging switch is used to charge the capacitor bank, which acts as a DC potential source to the battery. The capacitor bank is then disconnected from the power rectifier circuit. The pulse battery charger is then transferred to a second field effect switch through the second channel for the discharge phase. The discharge phase is driven by a transistor, and that transistor is driven via an optical coupler. When the second (discharge) switch is turned on, the capacitor bank potential charge is discharged into the battery waiting to receive the charge. The battery receiving the charge is then disconnected from the pulse-charger capacitor bank in order to repeat the cycle. The pulse-charger may have any suitable source of input power including:

- (1) solar panels to raise the voltage to the capacitor bank;
- (2) a wind generator;
- (3) a DC-to-DC inverter;
- (4) an alternator;
- (5) an AC motor generator;
- (6) a static source such as a high voltage spark; and
- (7) other devices which can raise the potential of the capacitor bank.

In another embodiment of the invention, one can use the pulse-charger to drive a device such as a motor or heating element with pulses of energy.

BRIEF DESCRIPTION OF THE DRAWINGS

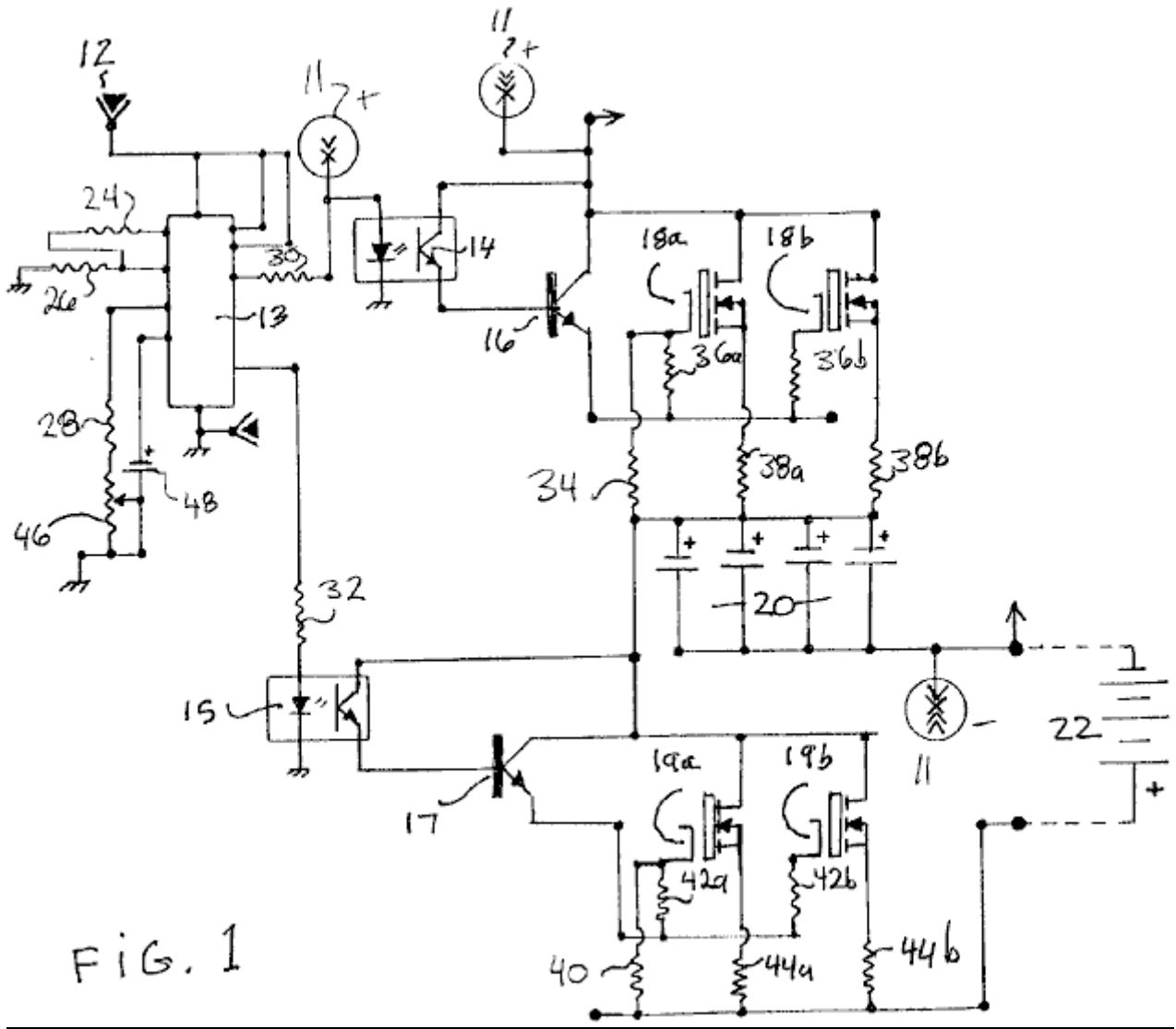

FIG. 1

Fig.1 is a schematic drawing of a solid-state pulse-charger according to an embodiment of the invention.

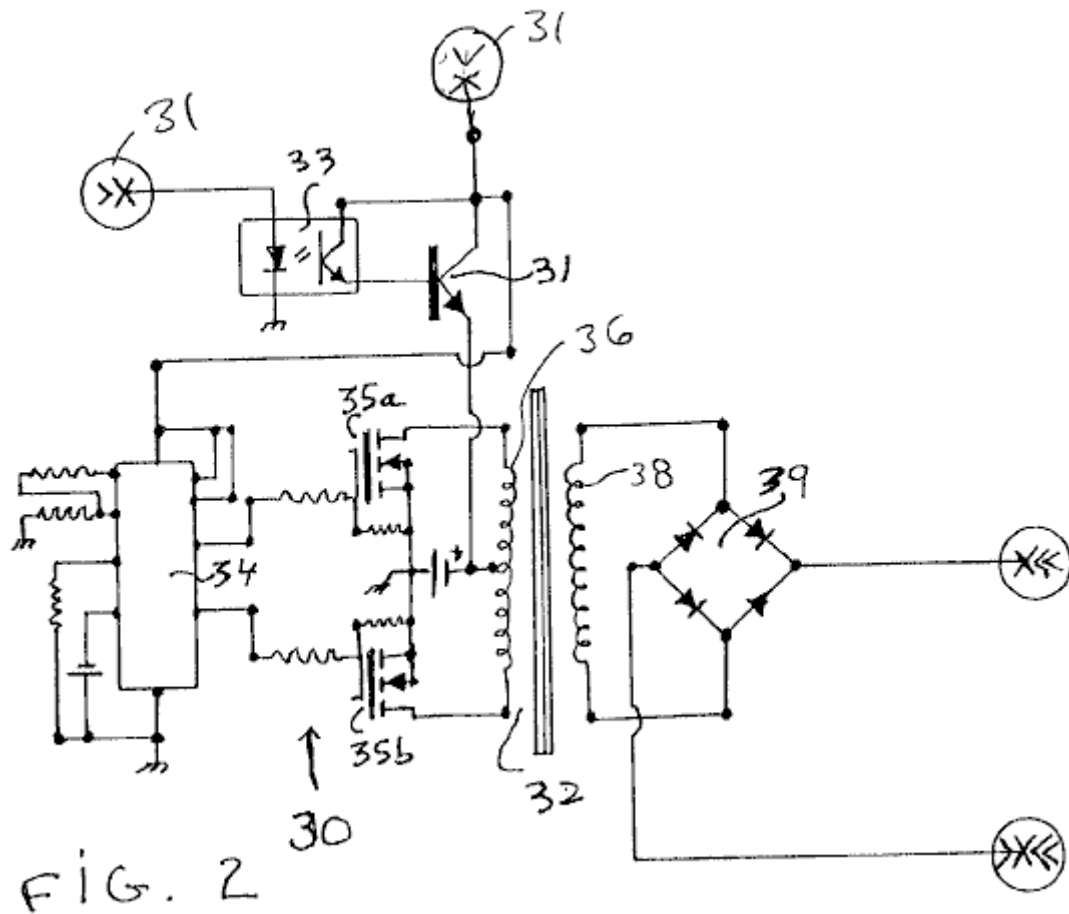

Fig.2 is a schematic drawing of a conventional DC-to-DC converter that can be used to provide power to the pulse-charger of Fig.1 according to an embodiment of the invention.

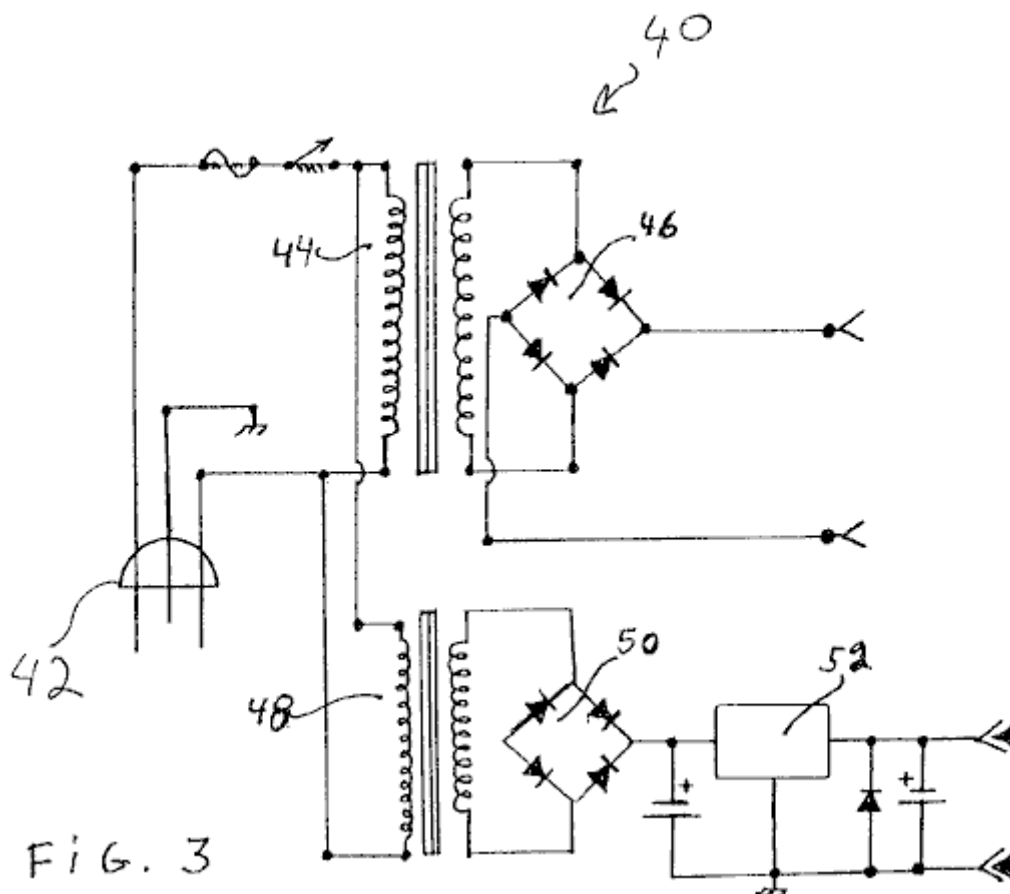

Fig.3 is a schematic drawing of a conventional AC power supply that can be used to provide power to the pulse-charger of Fig.1 according to an embodiment of the invention.

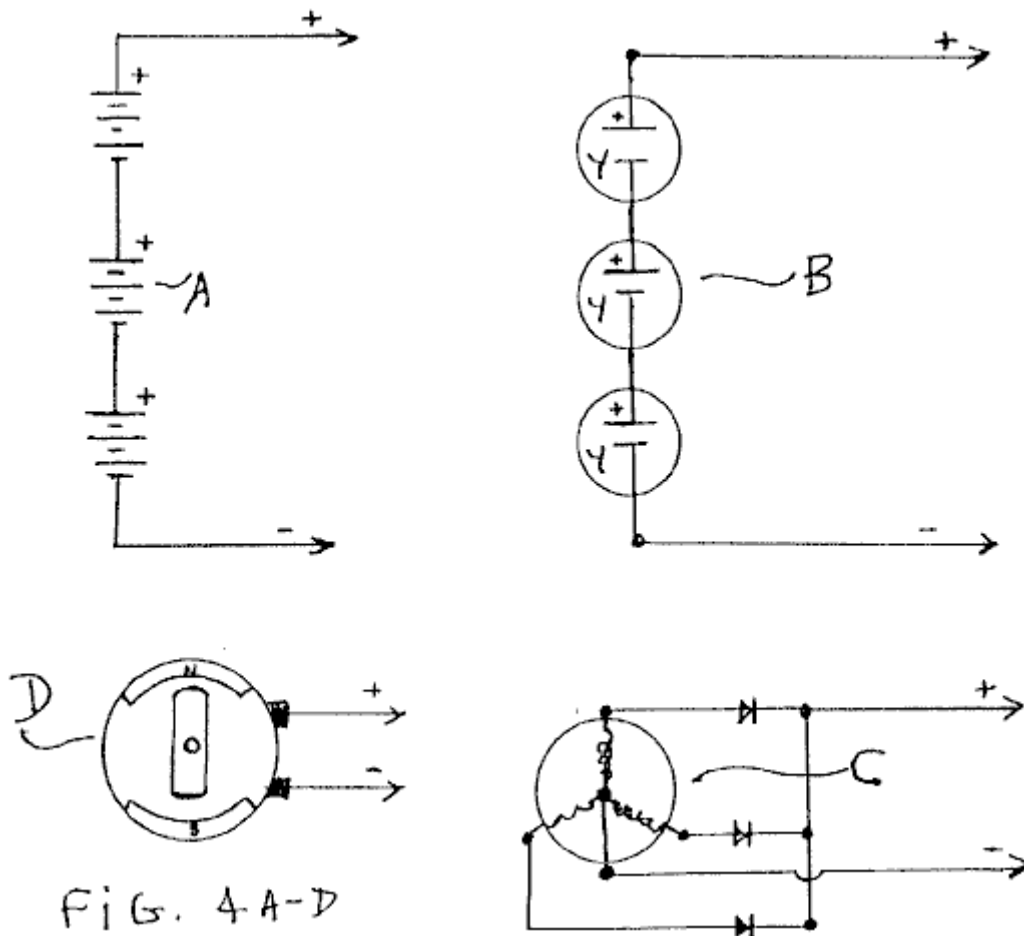

Fig.4A to Fig.4D are schematic drawings of other conventional power supplies that can be used to provide power to the pulse-charger of Fig.1 according to an embodiment of the invention.

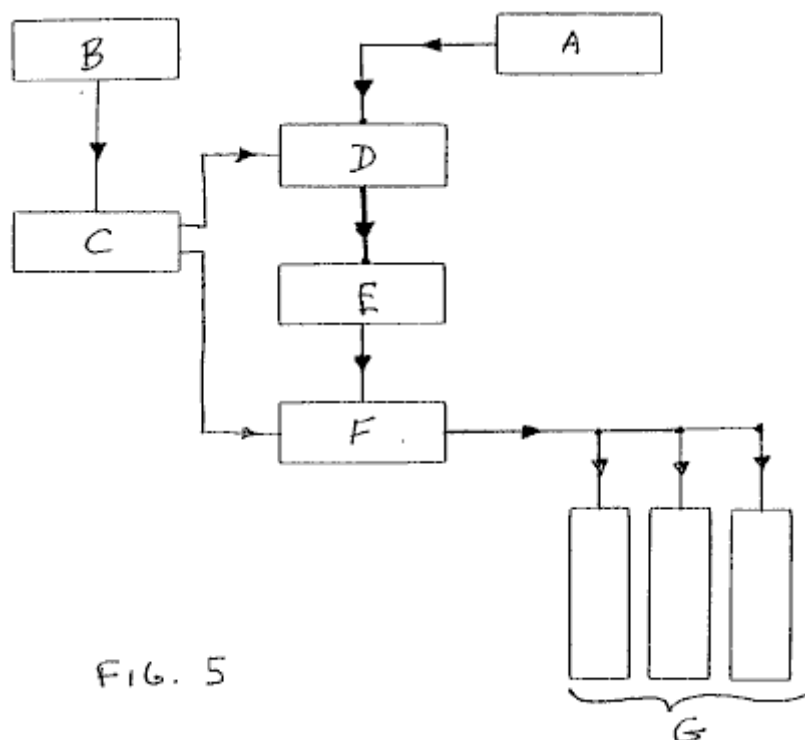

Fig.5 is a block diagram of the solid-state pulse-charger of Fig.1 according to an embodiment of the invention.

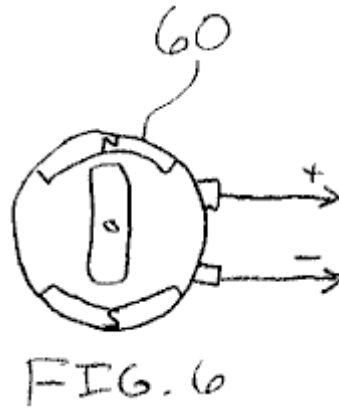

Fig.6 is a diagram of a DC motor that the pulse-charger of Fig.1 can drive according to an embodiment of the invention.

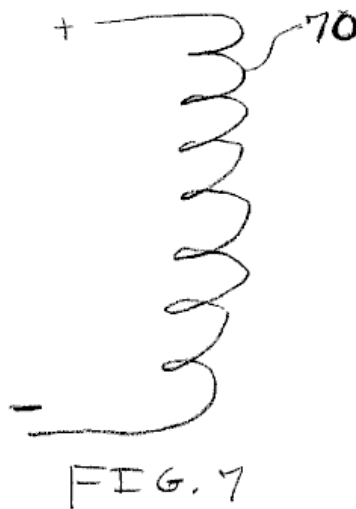

Fig.7 is a diagram of a heating element that the pulse-charger of Fig.1 can drive according to an embodiment of the invention.

DETAILED DESCRIPTION OF THE INVENTION

An embodiment of the present invention is a device and method for a solid-state pulse-charger that uses a stored potential charge in a capacitor bank. The solid-state pulse-charger comprises a combination of elements and circuitry to capture and store available energy in a capacitor bank. The stored energy in the capacitors is then pulse-charged into the battery to be charged. In one version of this embodiment, there is a first momentary disconnection between the charger and the battery receiving the charge during the charge phase of the cycle, and a second momentary disconnection between the charger and the input energy source during the discharge phase of the cycle.

As a starting point, and an arbitrary method in describing this device and method, the flow of an electrical signal or current will be tracked from the primary input energy to final storage in the battery receiving the pulse charge.

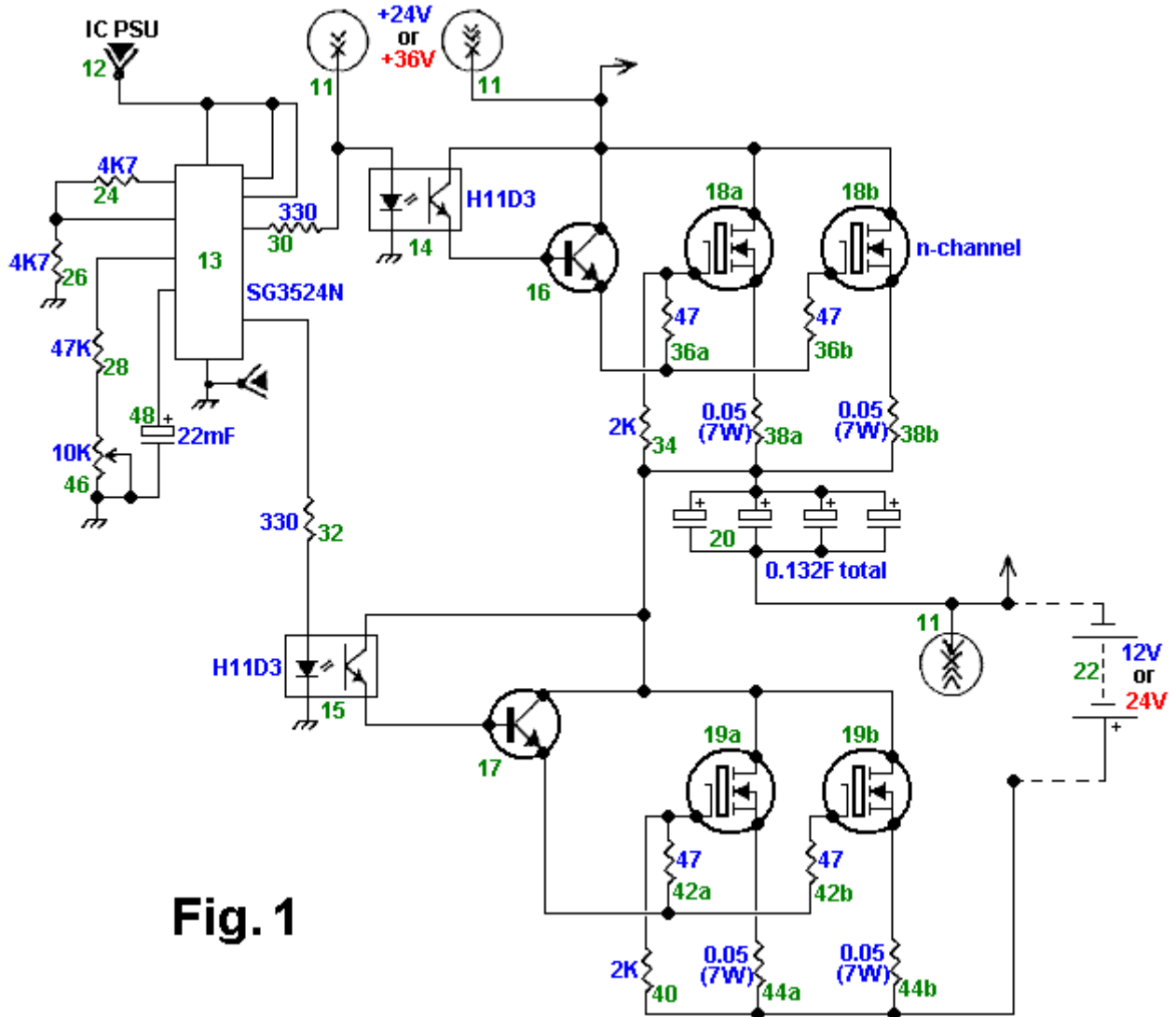

Fig. 1

Fig.1 is a schematic drawing of the solid-state pulse-charger according to an embodiment of the invention. As shown in **Fig.1**, the primary input energy source to the pulse-charger is a power supply **11**, examples of which are shown in **Fig.2**, **Fig.3**, and **Figs.4A-4D**. A 12-volt battery, as a low voltage energy source **12**, drives a dual switching means of control such as a logic chip or a pulse-width modulator (PWM) **13**.

Alternatively, the voltage from the power supply **11** may be converted to a voltage suitable to power the PWM **13**. The PWM **13** may be an SG3524N logic chip, and functions as an oscillator or timer to drive a 2-channel output with "on/off" switches that are connected when on to either a first optical isolator **14**, or alternatively, to a second optical isolator **15**. The first and second optical isolators **14** and **15** may be H11D3 optical isolators. When the logic chip **13** is connected to a first channel, it is disconnected from a second channel, thus resulting in two phases of signal direction; phase 1, a charge phase, and phase 2, a discharge phase.

When the logic chip **13** is switched to the charge phase, the signal flows to the first optical isolator **14**. From the optical isolator **14**, the signal continues its flow through a first NPN power transistor **16** that activates an N-channel MOSFET **18a** and an N-channel MOSFET **18b**. Current flowing through the MOSFETs **18a** and **18b** builds up a voltage across a capacitor bank **20**, thereby completing the charge phase of the switching activity.

The discharge phase begins when the logic chip **13** is switched to the second channel, with current flowing to the second optical isolator **15** and then through a second NPN power transistor **17**, which activates an N-channel MOSFET **19a** and an N-channel MOSFET **19b**. After the logic chip **13** closes the first channel and opens the second channel, the potential charge in the capacitor bank **20** is free floating between the power supply **11**, from which the capacitor bank **20** is now disconnected, and then connected to a battery **22** to receive the charge. It is at this point in time that the potential charge in the capacitor bank **20** is discharged through a high-energy pulse into the battery **22** or, a bank (not shown) of batteries. The discharge phase is completed once the battery **22** receives the charge. The logic chip **13** then switches the second channel closed and opens the first channel thus completing the charge-discharge cycle. The cycle is repetitive with the logic chip **13** controlling the signal

direction into either channel one to the capacitor bank, or to channel two to the battery **22** from the capacitor bank. The battery **22** is given a momentary rest period without a continuous current during the charge phase.

The component values for the described embodiment are as follows. The resistors **24**, **26**, . . . **44b** have the following respective values: 4.7K, 4.7K, 47K, 330, 330, 2K, 47, 47, 0.05(7W), 0.05(7W), 2K, 47, 47, 0.05(7 W), and 0.05(7W). The potentiometer **46** is 10K, the capacitor **48** is 22 mF, and the total capacitance of the capacitor bank **20** is 0.132F. The voltage of the battery **22** is between 12-24 V, and the voltage of the power supply **11** is 24-50 V such that the supply voltage is approximately 12-15 V higher than the battery voltage.

Other embodiments of the pulse-charger are contemplated. For example, the bipolar transistors **16** and **17** may be replaced with field-effect transistors, and the transistors **18a**, **18b**, **19a**, and **19b** may be replaced with bipolar or insulated-gate bipolar (IGBT) transistors. Furthermore, one can change the component values to change the cycle time, the peak pulse voltage, the amount of charge that the capacitor bank **20** delivers to the battery **22**, etc. In addition, the pulse-charger can have one or more than two transistors **18a** and **18b**, and one or more than two transistors **19a** and **19b**.

Still referring to **Fig.1**, the operation of the above-discussed embodiment of the pulse-charger is discussed. To begin the first phase of the cycle during which the capacitor bank **20** is charged, the logic circuit **13** deactivates the isolator **15** and activates the isolator **14**. Typically, the circuit **13** is configured to deactivate the isolator **15** before or at the same time that it activates the isolator **14**, although the circuit **13** may be configured to deactivate the isolator **15** after it activates the isolator **14**.

Next, the activated isolator **14** generates a base current that activates the transistor **16**, which in turn generates a current that activates the transistors **18a** and **18b**. The activated transistors **18a** and **18b** charge the capacitors in the bank **20** to a charge voltage equal or approximately equal to the voltage of the power supply **11** less the lowest threshold voltage of the transistors **18a** and **18b**. To begin the second phase of the cycle during which the capacitor bank **20** pulse charges the battery **22**, the logic circuit **13** deactivates the isolator **14** and activates the isolator **15**. Typically, the circuit **13** is configured to deactivate the isolator **14** before or at the same time that it activates the isolator **15**, although the circuit **13** may be configured to deactivate the isolator **14** after it activates the isolator **15**.

Next, the activated isolator **15** generates a base current that activates the transistor **17**, which in turn generates a current that activates the transistors **19a** and **19b**. The activated transistors **19a** and **19b** discharge the capacitors in the bank **20** into the battery **22** until the voltage across the bank **20** is or is approximately equal to the voltage across the battery **22** plus the lowest threshold voltage of the transistors **19a** and **19b**. Alternatively, the circuit **13** can deactivate the isolator **15** at a time before the bank **20** reaches this level of discharge. Because the resistances of the transistors **19a** and **19b**, the resistors **44a** and **44b**, and the battery **22** are relatively low, the capacitors in the bank **20** discharge rather rapidly, thus delivering a pulse of current to charge the battery **22**. For example, where the pulse-charger includes components having the values listed above, the bank **20** delivers a pulse of current having a duration of about 100 ms and a peak of about 250 A.

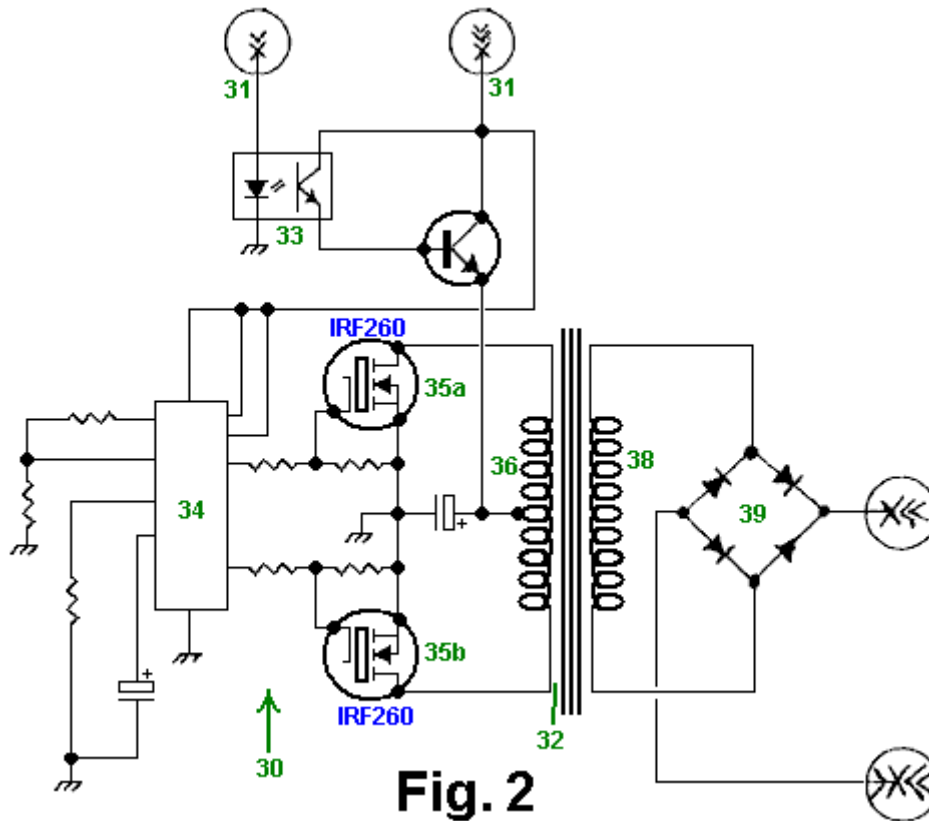

Fig. 2

Fig.2 is a schematic drawing of a conventional DC-to-DC converter **30** that can be used as the power supply **11** of **Fig.1** according to an embodiment of the invention. A DC-to-DC converter converts a low DC voltage to a higher DC voltage or vice-versa. Therefore, such a converter can convert a low voltage into a higher voltage that the pulse-charger of **Fig.1** can use to charge the capacitor bank **20** (**Fig.1**). More specifically, the converter **30** receives energy from a source **31** such as a 12-volt battery. An optical isolator sensor **33** controls an NPN power transistor which provides a current to a primary coil **36** of a power transformer **32**. A logic chip or pulse width modulator (PWM) **34** alternately switches on and off an IRF260 first N-channel MOSFET **35a** and an IRF260 second N-channel MOFSET **35b** such that when the MOSFET **35a** is on the MOSFET **35b** is off and vice-versa. Consequently, the switching MOSFETs **35a** and **35b** drive respective sections of the primary coil **36** to generate an output voltage across a secondary coil **38**. A full-wave bridge rectifier **39** rectifies the voltage across the secondary coil **38**, and this rectified voltage is provided to the pulse-charger of **Fig.1**. Furthermore, the secondary coil **38** can be tapped to provide a lower voltage for the PWM **13** of **Fig.1** such that the DC-to-DC converter **30** can be used as both the power supply **11** and the low-voltage supply **12** of **Fig.1**.

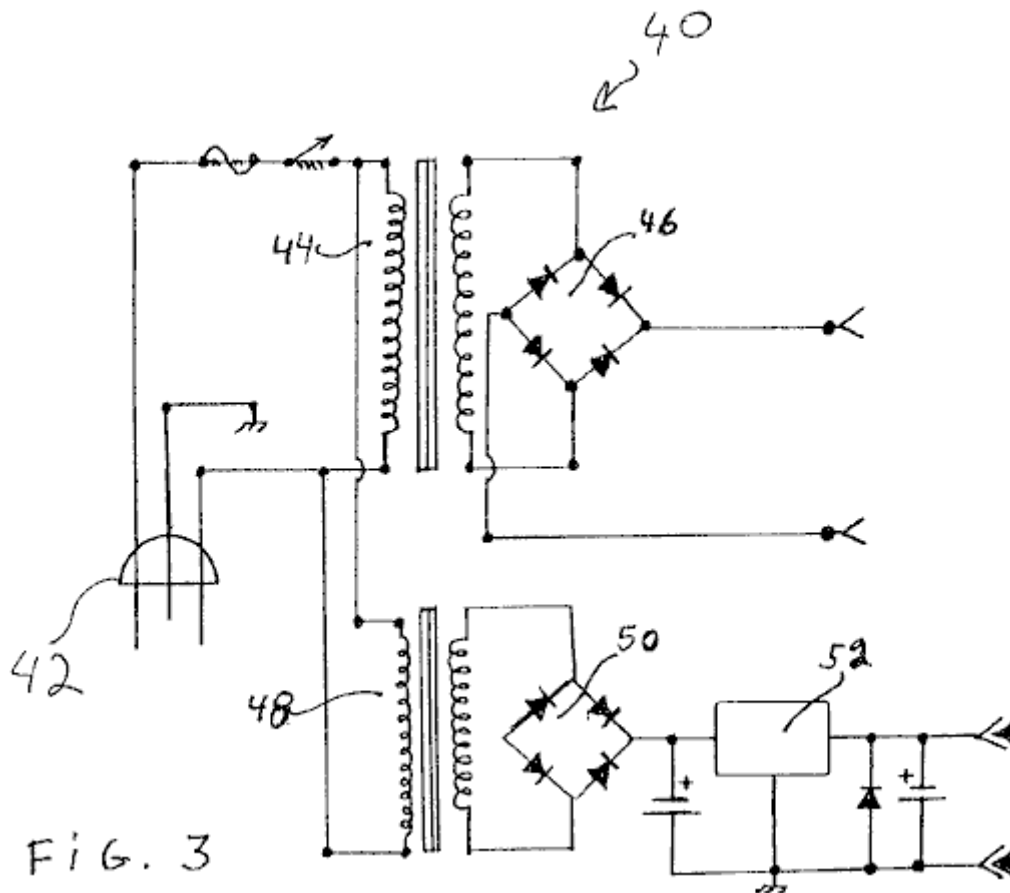

FIG. 3

Fig.3 is a schematic drawing of an AC power supply 40 that can be used as both the power supply 11 and the power supply 12 of Fig.1 according to an embodiment of the invention. The power input 42 to the supply 40 is 120V AC. A first transformer 44 and full-wave rectifier 46 compose the supply 11, and a second transformer 48, full-wave rectifier 50, and voltage regulator 52 compose the supply 12.

Fig.4A to Fig.4D are schematic drawings of various conventional primary energy input sources which can be used as the supply 11 and/or the supply 12 of Fig.1 according to an embodiment of the invention. Fig.4A is a schematic drawing of serially coupled batteries. Fig.4B is a schematic drawing of serially-coupled solar cells. Fig.4C is a schematic drawing of an AC generator, and Fig.4D is a schematic drawing of a DC generator.

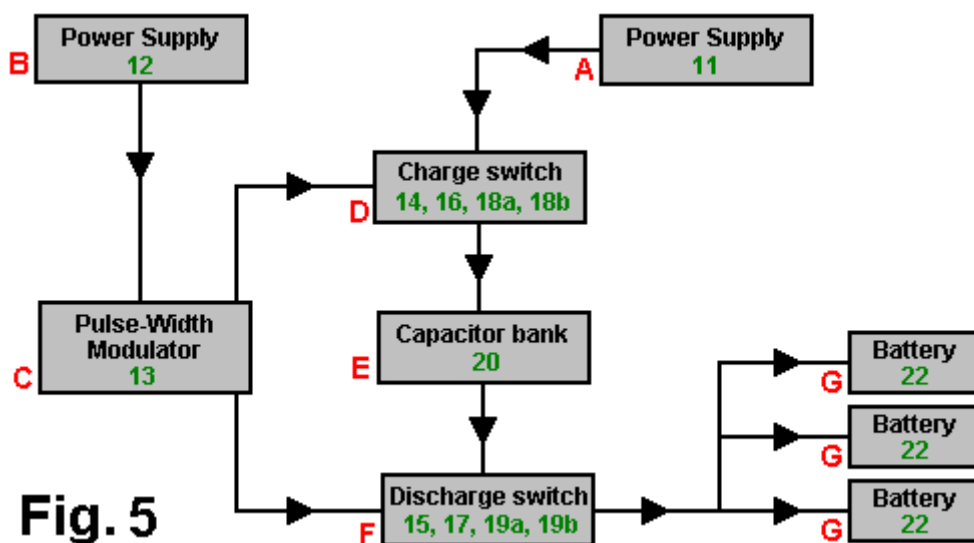

Fig. 5

Fig.5 is a block diagram of the solid-state pulse-charger of Fig.1 according to an embodiment of the invention. Block A is the power supply 11, which can be any suitable power supply such as those shown in Fig.2, Fig.3, Figs.4A-4D. Block B is the power supply 12, which can be any suitable power supply such as a 12V DC supply or the supply shown in Fig.3. Block C is the PWM 13 and its peripheral components. Block D is the charge switch that includes the first optical isolator chip 14, the first NPN power transistor 16, the first set of two N-

channel MOSFETs **18a** and **18b**, and their peripheral resistors. Block **E** is the capacitor bank **20**. Block **F** is the discharge switch that includes the second optical isolator chip **15**, the second NPN power transistor **17**, the second set of two N-channel MOSFETs **19a** and **19b**, and their peripheral resistors. Block **G** is the battery or battery bank **22** which is being pulse-charged.

A unique feature that distinguishes one embodiment of the pulse-charger described above, from conventional chargers is the method charging the battery with pulses of current instead of with a continuous current. Consequently, the battery is given a reset period between pulses.

Fig.6 is a diagram of a DC motor **60** that the pulse-charger of **Fig.1** can drive according to an embodiment of the invention. Specifically, one can connect the motor **60** in place of the battery **22** (**Fig.1**) such that the pulse-charger drives the motor with pulses of current. Although one need not modify the pulse-charger to drive the motor **60**, one can modify it to make it more efficient for driving the motor. For example, one can modify the values of the resistors peripheral to the PWM **13** (**Fig.1**) to vary the width and peak of the drive pulses from the capacitor bank **20** (**Fig.1**).

Fig.7 is a diagram of a heating element **70**, such as a dryer or water-heating element, that the pulse-charger of **Fig.1** can drive according to an embodiment of the invention. Specifically, one can connect the heating element **70** in place of the battery **22** (**Fig.1**) such that the pulse-charger drives the element with pulses of current. Although one need not modify the pulse-charger to drive the element **70**, one can modify it to make it more efficient for driving the element. For example, one can modify the values of the resistors peripheral to the PWM **13** (**Fig.1**) to vary the width and peak of the drive pulses from the capacitor bank **20** (**Fig.1**).

In the embodiments discussed above, specific electronic elements and components are used. However, it is known that a variety of available transistors, resistors, capacitors, transformers, timing components, optical isolators, pulse width modulators, MOSFETs, and other electronic components may be used in a variety of combinations to achieve an equivalent result. Finally, although the invention has been described with reference of particular means, materials and embodiments, it is to be understood that the invention is not limited to the particulars disclosed and extends to all equivalents within the scope of the claims.

CLAIMS

1. A solid-state pulse battery charger wherein input power from a primary source is stored as a potential charge in a capacitor bank, said capacitor bank then disconnected from said input power source through a dual timing means, said capacitor then connected to a battery to receive the potential charge, the charge then discharged into said battery from said capacitor, said battery then disconnected from said capacitor through said dual timing means, said capacitor then re-connected to said input power source completing a two phase switching cycle comprising:
 - a. a means for providing input power;
 - b. a means for timing a signal and a current flow in two phases, a charge phase and a discharge phase, through either a first channel output for charging said capacitor bank, or a second channel output for discharging stored energy from said capacitor into said battery, the current flowing from said first channel output through a first optical isolator and through a first NPN power transistor, said first transistor activating a first pair of N-channel MOSFETs with voltage stored as the potential charge in said capacitor bank, said capacitor disconnecting from said input power means by said timing means;
 - c. said means for timing current flow connecting to said second channel output, current flowing from said second channel through a second optical isolator and through a second NPN power transistor, said second transistor activating a second pair of N-channel MOSFETs, said capacitor connecting to said battery, the potential charge discharging into said battery, said timing means disconnecting said capacitor from said battery, and connecting said capacitor to said power means.
2. The pulse-charger of claim 1 wherein the means for providing input power is an AC voltage current.
3. The pulse-charger of claim 1 wherein the means for providing input power is a battery.
4. The pulse-charger of claim 1 wherein the means for providing input power is a DC generator.
5. The pulse-charger of claim 1 wherein the means for providing input power is an AC generator.
6. The pulse-charger of claim 1 wherein the means for providing input power is a solar cell.
7. The pulse-charger of claim 1 wherein the means for providing input power is a DC-to-DC inverter.

8. The pulse-charger of claim 1 wherein the means for timing a signal is a pulse width modulator, said modulator an SG3524N logic chip.
9. The pulse-charger of claim 1 wherein the optical isolator is an H11D3 isolator.
10. The pulse-charger of claim 1 wherein the NPN power transistor is an MJE15024 transistor.
11. The pulse-charger of claim 1 wherein the N-channel MOSFET is a IRF260 MOSFET.
12. A solid-state pulsed battery charger wherein input power from a primary source is stored as a potential charge in a capacitor bank, said capacitor then disconnected from said input power source through a dual timing means, said capacitor then connected to a battery to receive the potential charge, the charge then discharged into said battery from said capacitor, said battery then disconnected from said capacitor through said dual timing means, said capacitor then reconnected to said input power source completing a two phase cycle comprising:
 - a. a means for providing said input power, said means either an AC voltage current, or a battery, or a DC generator, or an AC generator, or a solar cell, or a DC-to-DC inverter;
 - b. a means for timing a signal and a current flow, said timing means a pulse width modulator, logic chip SG3524N, the current flowing through either a first channel output, or a second channel output, the current flowing from said first channel output through a first optical isolator, said isolator an H11D3, and through a first NPN power transistor, said transistor an MJE15024, said first transistor activating a first pair of N-channel MOSFETs, said MOSFETs an IRF260, with current voltage stored as the potential charge in said capacitor bank, said capacitor disconnecting from said input power means by said logic chip;
 - c. said timing logic chip connecting to said second channel output, current flowing from said second channel through a second optical isolator, said isolator an H11D3, and through a second NPN power transistor, said second transistor an MJE15024, and activating a second pair of N-channel MOSFETs, said MOSFETs an IRF260, with current voltage stored as the potential charge in said capacitor bank, said capacitor disconnecting from said input power means by said logic chip, said capacitor connecting to said battery, the potential charge discharging into said battery, said timing means disconnecting said capacitor from said battery and connecting said capacitor to said power means.
13. A method of making a solid-state pulse battery charger wherein input power from a primary source is stored as a potential charge in a capacitor bank, said capacitor disconnected from said input power source through a dual timing means, said capacitor connected to a battery to receive the potential charge, said charge discharged into said battery from said capacitor, said battery disconnected from said capacitor through said dual timing means, said capacitor reconnected to said input power source completing a two phase cycle comprising the steps of:
 - a. providing a source of input power;
 - b. connecting a means for dual-timing said charger to control a signal or current flow through a first channel output comprising a first optical isolator, a first NPN power transistor and a first pair of N-channel MOSFETs;
 - c. capturing energy from said current and storing said energy in said capacitor bank thereby charging said capacitor;
 - d. switching the flow of said current using said timing device to a second channel comprising a second optical isolator, a second NPN power transistor and a second pair of N-channel MOSFETs, thus disconnecting said capacitor from said power source and connecting said capacitor to said battery;
 - e. discharging the potential charge into said battery;
 - f. switching the flow of the current using said timing device to said power source and said first channel to complete said cycle.
14. The pulse-charger of claim 13 wherein the means for providing input power is an AC voltage current.
15. The pulse-charger of claim 13 wherein the means for providing input power is a battery.
16. The pulse-charger of claim 13 wherein the means for providing input power is a DC generator.
17. The pulse-charger of claim 13 wherein the means for providing input power is an AC generator.
18. The pulse-charger of claim 13 wherein the means for providing input power is a solar cell.
19. The pulse-charger of claim 13 wherein the means for providing input power is a DC-to-DC inverter.
20. The pulse-charger of claim 13 wherein the means for timing a signal is a pulse width modulator, said modulator an SG3524N logic chip.

21. The pulse-charger of claim 13 wherein the optical isolator is an H11D3 isolator.
22. The pulse-charger of claim 13 wherein the NPN power transistor is an MJE15024 transistor.
23. The pulse-charger of claim 13 wherein the N-channel MOSFET is a IRF260 MOSFET.
24. A battery charger, comprising:
 - a supply node;
 - a charge node;
 - a switch circuit coupled to the supply and the charge nodes and operable to, allow a battery-charge current to flow into the charge node during a battery-charge period, and prohibit the battery-charge current from flowing into the charge node during a battery-rest period.
25. The battery charger of claim 24, further comprising:
 - a charge-storage device coupled to the switch circuit; and
 - wherein the switch circuit is operable to, allow the battery-charge current to flow from the charge-storage device into the charge node during the battery-charge period, and charge the charge-storage device during the battery-rest period.
26. The battery charger of claim 24, further comprising:
 - a capacitor coupled to the switch circuit; and
 - wherein the switch circuit is operable to, allow the battery-charge current to from the capacitor into the charge node during the battery-charge period, and charge the capacitor during the battery-rest period.
27. A method, comprising:
 - charging a battery during a first period of a charge cycle; and
 - prohibiting the charging of the battery during a second period of the charge cycle.
28. The method of claim 27 wherein:
 - charging the battery comprises charging the battery with a charge current during the first period of the charge cycle; and
 - prohibiting the charging of the battery comprises prohibiting the charge current from flowing into the battery during the second period of the charge cycle.
29. The method of claim 27 wherein:
 - charging the battery comprises discharging a capacitor into the battery during the first period of the charge cycle; and
 - prohibiting the charging of the battery comprises uncoupling the capacitor from the battery during the second period of the charge cycle.
30. The method of claim 27, further comprising:
 - wherein charging the battery comprises discharging a capacitor into the battery during the first period of the charge cycle;
 - wherein prohibiting the charging of the battery comprises uncoupling the capacitor from the battery during the second period of the charge cycle; and
 - charging the capacitor during the second period of the charge cycle.
31. A method, comprising:
 - discharging a charge-storage device into a battery during a first period of a battery-charge cycle; and
 - uncoupling the charge-storage device from the battery and charging the charge-storage device during a second period of the battery-charge cycle.
32. The method of claim 31 wherein uncoupling the charge-storage device comprises uncoupling the charge-storage device from the battery before commencing charging of the charge-storage device.
33. The method of claim 31 wherein uncoupling the charge-storage device comprises uncoupling the charge-storage device from the battery after commencing charging of the charge-storage device.
34. The method of claim 31 wherein uncoupling the charge-storage device comprises simultaneously uncoupling the charge-storage device from the battery and commencing charging of the charge-storage device.

Notes:

The following information is NOT part of John's patent. It is information intended to be helpful, but as it is not coming from John it must be considered to be opinion and not fact. In the above diagrams, the SG3524N integrated circuit is likely to be unfamiliar to many readers, and an examination of the specification sheet does not make it obvious which pin connections are used in John's circuit. The following pin connections are believed to be correct, but cannot be guaranteed.

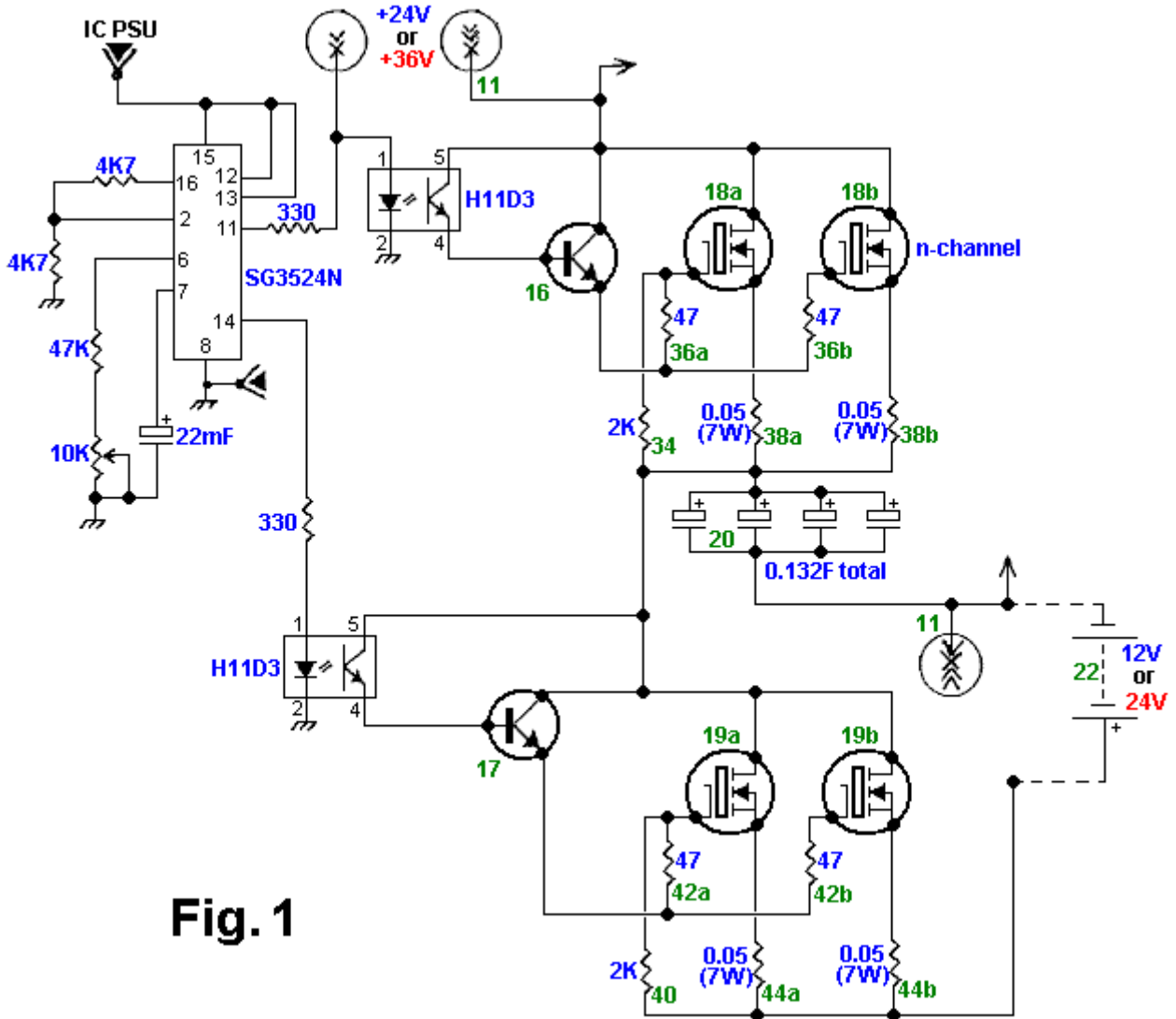
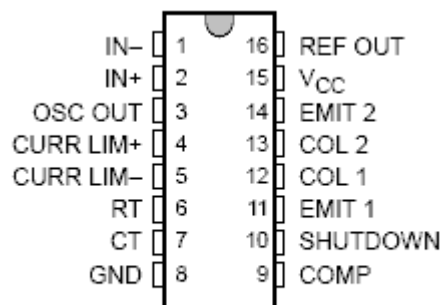

Fig. 1

In addition to these SG3524N pin connections, it is suggested that pins 1, 4 and 5 be connected to ground instead of just pin 8, and that a 100nF capacitor be connected from pin 9 to ground. Pins 3 and 10 are left unconnected. The pinouts for the chip are:



SG3524N

RICHARD WEIR and CARL NELSON

US Patent 7,033,406

25th April 2006

Inventors: Richard Weir and Carl Nelson

ELECTRICAL-ENERGY-STORAGE UNIT UTILISING CERAMIC AND INTEGRATED-CIRCUIT TECHNOLOGIES FOR REPLACEMENT OF ELECTROCHEMICAL BATTERIES

This patent shows an electrical storage method which is reputed to power an electric car for a 500 mile trip on a charge taking only five minutes to complete. This document is a very slightly re-worded copy of the original. It has been pointed out by Mike Furness that while a five minute recharge is feasible, it is not practical, calling for cables with a six-inch diameter. Also, the concept of recharging stations as suggested is also rather improbable as the electrical supply needed would rival that of a power station. However, if the charging time were extended to night time, then it would allow substantial driving range during the day time.

ABSTRACT

An Electrical-Energy-Storage Unit (EESU) has as a basis material a high-permittivity, composition-modified barium titanate ceramic powder. This powder is double coated with the first coating being aluminium oxide and the second coating calcium magnesium aluminosilicate glass. The components of the EESU are manufactured with the use of classical ceramic fabrication techniques which include screen printing alternating multi-layers of nickel electrodes and high-permittivity composition-modified barium titanate powder, sintering to a closed-pore porous body, followed by hot-isostatic pressing to a void-free body. The components are configured into a multi-layer array with the use of a solder-bump technique as the enabling technology so as to provide a parallel configuration of components that has the capability to store electrical energy in the range of 52 kWh. The total weight of an EESU with this range of electrical energy storage is about 336 pounds.

BACKGROUND OF THE INVENTION

1. Field of the Invention

This invention relates generally to energy-storage devices, and relates more particularly to high-permittivity ceramic components utilised in an array configuration for application in ultra high electrical-energy storage devices.

2. Description of the Relevant Art

The internal-combustion-engine (ICE) powered vehicles have as their electrical energy sources a generator and battery system. This electrical system powers the vehicle accessories, which include the radio, lights, heating, and air conditioning. The generator is driven by a belt and pulley system and some of its power is also used to recharge the battery when the ICE is in operation. The battery initially provides the required electrical power to operate an electrical motor that is used to turn the ICE during the starting operation and the ignition system.

The most common batteries in use today are:

Flooded lead-acid,
Sealed gel lead-acid,
Nickel-Cadmium (Ni-Cad),
Nickel Metal Hydride (NiMH), and
Nickel-Zinc (Ni-Z).

References on the subject of electrochemical batteries include the following:

Guardian, Inc., "[Product Specification](#)": Feb. 2, 2001;
K. A. Nishimura, "[NiCd Battery](#)", Science Electronics FAQ V1.00: Nov. 20, 1996;
Ovonics, Inc., "[Product Data Sheet](#)": no date;
Evercel, Inc., "[Battery Data Sheet—Model 100](#)": no date;
S. R. Ovshinsky et al., "[Ovonics NiMH Batteries: The Enabling Technology for Heavy-Duty Electrical and Hybrid Electric Vehicles](#)", Ovonics publication 2000-01-3108: Nov. 5, 1999;
B. Dickinson et al., "[Issues and Benefits with Fast Charging Industrial Batteries](#)", AeroVeronment, Inc. article: no date.

Each specific type of battery has characteristics, which make it either more or less desirable to use in a specific application. Cost is always a major factor and the NiMH battery tops the list in price with the flooded lead-acid battery being the most inexpensive. Evercel manufactures the Ni-Z battery and by a patented process, with the

claim to have the highest power-per-pound ratio of any battery. See Table 1 below for comparisons among the various batteries. What is lost in the cost translation is the fact that NiMH batteries yield nearly twice the performance (energy density per weight of the battery) than do conventional lead-acid batteries. A major drawback to the NiMH battery is the very high self-discharge rate of approximately 5% to 10% per day. This would make the battery useless in a few weeks. The Ni-Cad battery and the lead-acid battery also have self-discharge but it is in the range of about 1% per day and both contain hazardous materials such as acid or highly toxic cadmium. The Ni-Z and the NiMH batteries contain potassium hydroxide and this electrolyte in moderate and high concentrations is very caustic and will cause severe burns to tissue and corrosion to many metals such as beryllium, magnesium, aluminium, zinc, and tin.

Another factor that must be considered when making a battery comparison is the recharge time. Lead-acid batteries require a very long recharge period, as long as 6 to 8 hours. Lead-acid batteries, because of their chemical makeup, cannot sustain high current or voltage continuously during charging. The lead plates within the battery heat rapidly and cool very slowly. Too much heat results in a condition known as "gassing" where hydrogen and oxygen gases are released from the battery's vent cap. Over time, gassing reduces the effectiveness of the battery and also increases the need for battery maintenance, i.e., requiring periodic de-ionised or distilled water addition. Batteries such as Ni-Cad and NiMH are not as susceptible to heat and can be recharged in less time, allowing for high current or voltage changes which can bring the battery from a 20% state of charge to an 80% state of charge in just 20 minutes. The time to fully recharge these batteries can be more than an hour. Common to all present day batteries is a finite life, and if they are fully discharged and recharged on a regular basis their life is reduced considerably.

SUMMARY OF THE INVENTION

In accordance with the illustrated preferred embodiment, the present invention provides a unique electrical-energy-storage unit that has the capability to store ultra high amounts of energy.

One aspect of the present invention is that the materials used to produce the energy-storage unit, EESU, are not explosive, corrosive, or hazardous. The basis material, a high-permittivity calcined composition-modified barium titanate powder is an inert powder and is described in the following references: S. A. Bruno, D. K. Swanson, and I. Burn, J. Am Ceram. Soc. 76, 1233 (1993); P. Hansen, U.S. Pat. No. 6,078,494, issued Jun. 20, 2000. The most cost-effective metal that can be used for the conduction paths is nickel. Nickel as a metal is not hazardous and only becomes a problem if it is in solution such as in deposition of electroless nickel. None of the EESU materials will explode when being recharged or impacted. Thus the EESU is a safe product when used in electric vehicles, buses, bicycles, tractors, or any device that is used for transportation or to perform work. It could also be used for storing electrical power generated from solar voltaic cells or other alternative sources for residential, commercial, or industrial applications. The EESU will also allow power averaging of power plants utilising SPVC or wind technology and will have the capability to provide this function by storing sufficient electrical energy so that when the sun is not shining or the wind is not blowing they can meet the energy requirements of residential, commercial, and industrial sites.

Another aspect of the present invention is that the EESU initial specifications will not degrade due to being fully discharged or recharged. Deep cycling the EESU through the life of any commercial product that may use it will not cause the EESU specifications to be degraded. The EESU can also be rapidly charged without damaging the material or reducing its life. The cycle time to fully charge a 52 kWh EESU would be in the range of 4 to 6 minutes with sufficient cooling of the power cables and connections. This and the ability of a bank of EESUs to store sufficient energy to supply 400 electric vehicles or more with a single charge will allow electrical energy stations that have the same features as the present day gasoline stations for the ICE cars. The bank of EESUs will store the energy being delivered to it from the present day utility power grid during the night when demand is low and then deliver the energy when the demand hits a peak. The EESU energy bank will be charging during the peak times but at a rate that is sufficient to provide a full charge of the bank over a 24-hour period or less. This method of electrical power averaging would reduce the number of power generating stations required and the charging energy could also come from alternative sources. These electrical-energy-delivery stations will not have the hazards of the explosive gasoline.

Yet another aspect of the present invention is that the coating of aluminium oxide and calcium magnesium aluminosilicate glass on calcined composition-modified barium titanate powder provides many enhancement features and manufacturing capabilities to the basis material. These coating materials have exceptional high voltage breakdown and when coated on to the above material will increase the breakdown voltage of ceramics comprised of the coated particles from 3×10^6 V/cm of the uncoated basis material to around 5×10^6 V/cm or higher. The following reference indicates the dielectric breakdown strength in V/cm of such materials: J. Kuwata et al., "Electrical Properties of Perovskite-Type Oxide Thin-Films Prepared by RF Sputtering", Jpn. J. Appl. Phys., Part 1, 1985, 24(Suppl. 24-2, Proc. Int. Meet. Ferroelectr., 6th), 413-15. This very high voltage breakdown assists in allowing the ceramic EESU to store a large amount of energy due to the following: Stored energy $E = CV^2 / 2$,

Formula 1, as indicated in F. Sears et al., "Capacitance-Properties of Dielectrics", University Physics, Addison-Wesley Publishing Company, Inc.: Dec. 1957: pp 468-486, where C is the capacitance, V is the voltage across the EESU terminals, and E is the stored energy. This indicates that the energy of the EESU increases with the square of the voltage. **Fig.1** indicates that a double array of 2230 energy storage components 9 in a parallel configuration that contain the calcined composition-modified barium titanate powder. Fully densified ceramic components of this powder coated with 100 Angstrom units of aluminium oxide as the first coating 8 and a 100 Angstrom units of calcium magnesium aluminosilicate glass as the second coating 8 can be safely charged to 3500 V. The number of components used in the double array depends on the electrical energy storage requirements of the application. The components used in the array can vary from 2 to 10,000 or more. The total capacitance of this particular array 9 is 31 F which will allow 52,220 W-h of energy to be stored as derived by Formula 1.

These coatings also assist in significantly lowering the leakage and ageing of ceramic components comprised of the calcined composition-modified barium titanate powder to a point where they will not effect the performance of the EESU. In fact, the discharge rate of the ceramic EESU will be lower than 0.1% per 30 days which is approximately an order of magnitude lower than the best electrochemical battery.

A significant advantage of the present invention is that the calcium magnesium aluminosilicate glass coating assists in lowering the sintering and hot-isostatic-pressing temperatures to 800°C. This lower temperature eliminates the need to use expensive platinum, palladium, or palladium-silver alloy as the terminal metal. In fact, this temperature is in a safe range that allows nickel to be used, providing a major cost saving in material expense and also power usage during the hot-isostatic-pressing process. Also, since the glass becomes easily deformable and flowable at these temperatures it will assist in removing the voids from the EESU material during the hot-isostatic-pressing process. The manufacturer of such systems is Flow Autoclave Systems, Inc. For this product to be successful it is mandatory that all voids be removed to assist in ensuring that the high voltage breakdown can be obtained. Also, the method described in this patent of coating the calcium magnesium aluminosilicate glass ensures that the hot-isostatic-pressed double-coated composition-modified barium titanate high-relative-permittivity layer is uniform and homogeneous.

Yet another aspect of the present invention is that each component of the EESU is produced by screen-printing multiple layers of nickel electrodes with screening ink from nickel powder. Interleaved between nickel electrodes are dielectric layers with screening ink from calcined double-coated high-permittivity calcined composition-modified barium titanate powder. A unique independent dual screen-printing and layer-drying system is used for this procedure. Each screening ink contains appropriate plastic resins, surfactants, lubricants, and solvents, resulting in a proper rheology (the study of the deformation and flow of matter) for screen printing. The number of these layers can vary depending on the electrical energy storage requirements. Each layer is dried before the next layer is screen printed. Each nickel electrode layer 12 is alternately preferentially aligned to each of two opposite sides of the component automatically during this process as indicated in **Fig.2**. These layers are screen printed on top of one another in a continuous manner. When the specified number of layers is achieved, the component layers are then baked to obtain by further drying sufficient handling strength of the green plastic body. Then the array is cut into individual components to the specified sizes.

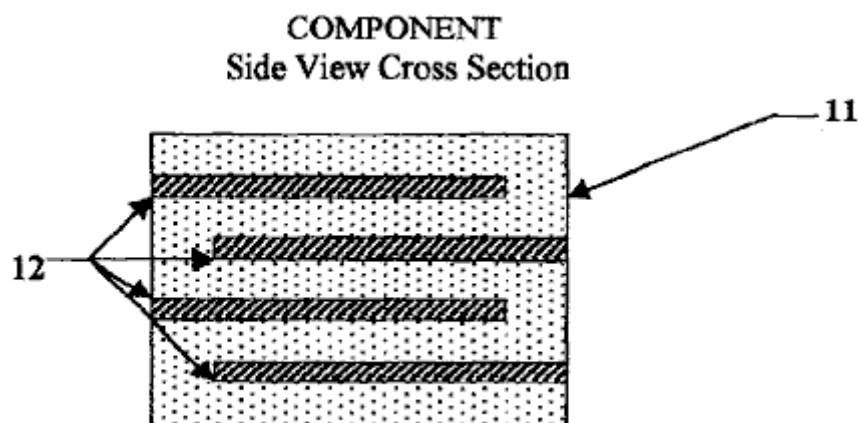

Figure 2

Alternatively, the dielectric powder is prepared by blending with plastic binders, surfactants, lubricants, and solvents to obtain a slurry with the proper rheology for tape casting. In tape casting, the powder-binder mixture is extruded by pressure through a narrow slit of appropriate aperture height for the thickness desired of the green plastic ceramic layer on to a moving plastic-tape carrier, known as a doctor-blade web coater. After drying, to develop sufficient handling strength of the green plastic ceramic layer, this layer is peeled away from the plastic-tape carrier. The green plastic ceramic layer is cut into sheets to fit the screen-printing frame in which the

electrode pattern is applied with nickel ink. After drying of the electrode pattern, the sheets are stacked and then pressed together to assure a well-bonded lamination. The laminate is then cut into components of the desired shape and size.

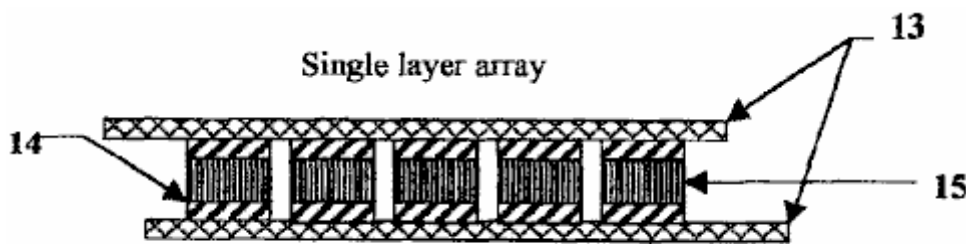

Figure 3

The components are treated for the binder-burnout and sintering steps. The furnace temperature is slowly ramped up to 350°C and held for a specified length of time. This heating is accomplished over a period of several hours so as to avoid any cracking and delamination of the body. Then the temperature is ramped up to 850°C and held for a specified length of time. After this process is completed the components are then properly prepared for the hot isostatic pressing at 700°C and the specified pressure. This process will eliminate voids. After this process, the components are then side-lapped on the connection side to expose the preferentially aligned nickel electrodes 12. Then these sides are dipped into ink from nickel powder that has been prepared to have the desired rheology. Then side conductors of nickel 14 are dipped into the same ink and then are clamped on to each side of the components 15 that have been dipped into the nickel powder ink. The components are then fired at 800°C for 20 minutes to bond the nickel bars to the components as indicated in Fig.3. The components are then assembled into a first-level array, Fig.3, with the use of the proper tooling and solder-bump technology. Then the first-level arrays are assembled to form a second-level array, Fig.4, by stacking the first array layers on top of one another in a preferential mode. Then nickel bars 18 are attached on each side of the second array as indicated in Fig.4. Then the EESU is packaged to form its final assembly configuration.

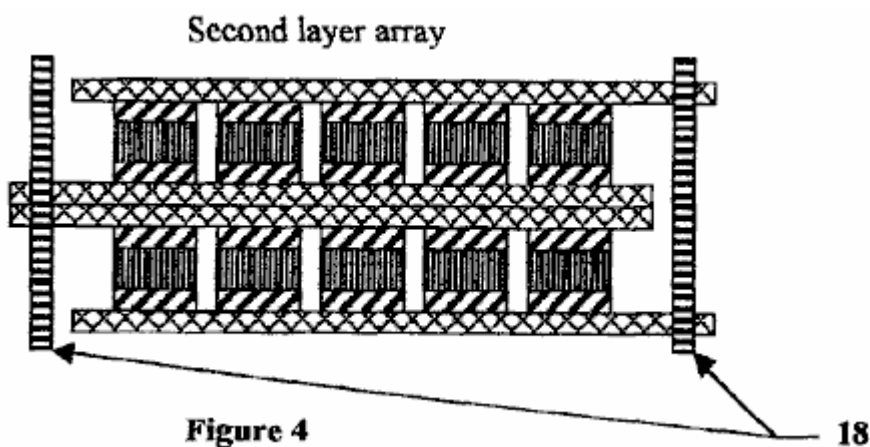

Figure 4

The features of this patent indicate that the ceramic EESU, as indicated in Table 1, outperforms the electrochemical battery in every parameter. This technology will provide mission-critical capability to many sections of the energy-storage industry.

TABLE 1

The parameters of each technology to store 52.2 kW · h of electrical energy are indicated-(data as of February 2001 from manufacturer's specification sheets).

	NiMH	LA(Gel)	Ceramic EESU	Ni—Z
Weight (pounds)	1,716	3,646	336	1,920
Volume (cu. inch)	17,881	43,045	2,005	34,780
Discharge rate	5% in 30 days	1% in 30 days	0.1% in 30 days	1% in 30 days
Charging time (full)	1.5 hours	8.0 hours	3 to 6 minutes	1.5 hours
Life reduced with deep cycle use	moderate	high	none	moderate
Hazardous materials	Yes	Yes	None	Yes

This EESU will have the potential to revolutionise the electric vehicle (EV) industry, the storage and use of electrical energy generated from alternative sources with the present utility grid system as a backup source for residential, commercial, and industrial sites, and the electric energy point of sales to EVs. The EESU will replace the electrochemical battery in any of the applications that are associated with the above business areas or in any business area where its features are required.

The features and advantages described in the specifications are not all inclusive, and particularly, many additional features and advantages will be apparent to one of ordinary skill in the art in view of the description, specification and claims made here. Moreover, it should be noted that the language used in the specification has been principally selected for readability and instructional purposes, and may not have been selected to delineate or circumscribe the inventive subject matter, resort to the claims being necessary to determine such inventive subject matter.

BRIEF DESCRIPTION OF THE DRAWINGS

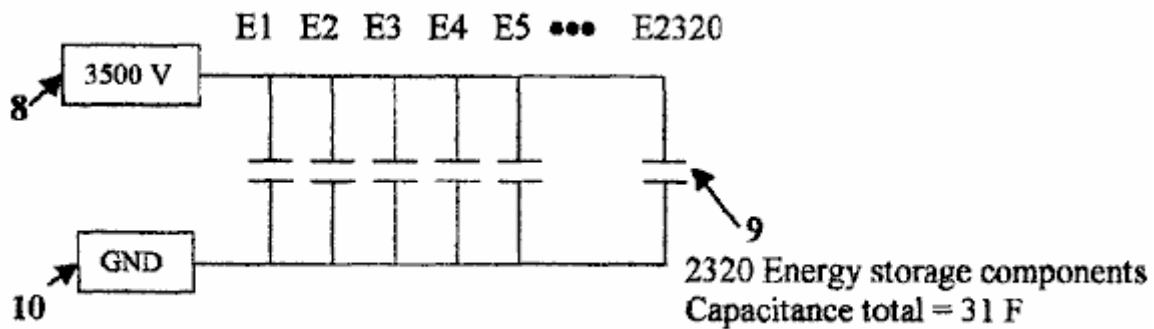

Figure 1

Fig.1 indicates a schematic of 2320 energy storage components **9** hooked up in parallel with a total capacitance of 31 Farads. The maximum charge voltage **8** of 3500 V is indicated with the cathode end of the energy storage components **9** hooked to system ground **10**.

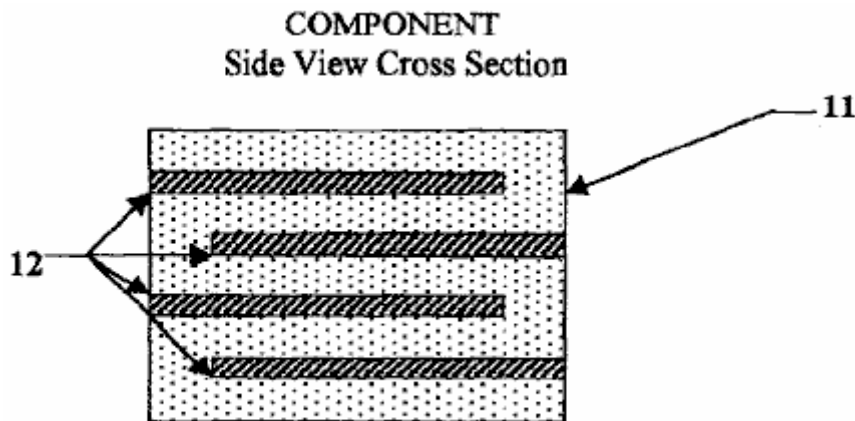

Figure 2

Fig.2 is a cross-section side view of the electrical-energy-storage unit component. This figure indicates the alternating layers of nickel electrode layers **12** and high-permittivity composition-modified barium titanate dielectric layers **11**. This figure also indicate the preferentially aligning concept of the nickel electrode layers **12** so that each storage layer can be hooked up in parallel.

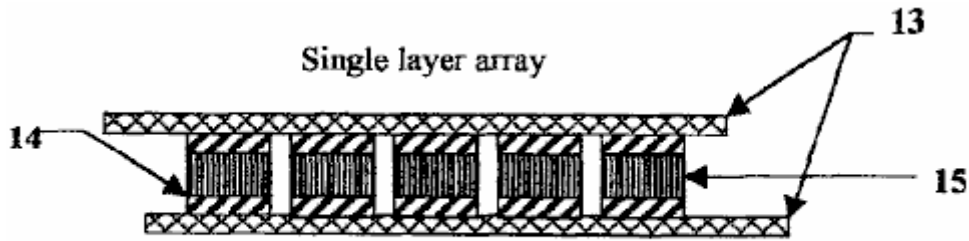

Figure 3

Fig.3 is side view of a single-layer array indicating the attachment of individual components **15** with the nickel side bars **14** attached to two preferentially aligned copper conducting sheets **13**.

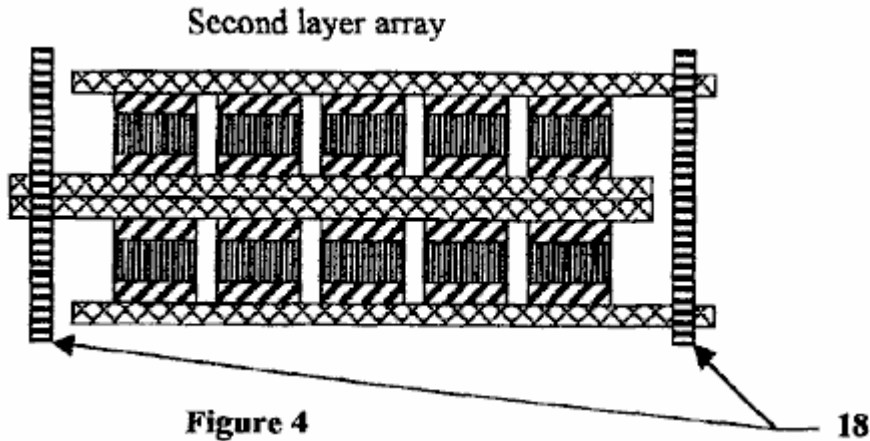

Figure 4

Fig.4 is a side view of a double-layer array with copper array connecting nickel bars **16** attaching the two arrays via the edges of the preferentially aligned copper conductor sheets **13**. This figure indicates the method of attaching the components in a multi-layer array to provide the required energy storage.

Reference No.	Refers to this in the drawings
8	System maximum voltage of 3500 V
9	2320 energy-storage components hooked up in parallel with a total capacitance of 31 Farad
10	System ground
11	High-permittivity calcined composition-modified barium titanate dielectric layers
12	Preferentially aligned nickel electrode layers
13	Copper conductor sheets
14	Nickel sidebars
15	Components
16	Copper array connecting nickel bars

DETAILED DESCRIPTION OF THE PREFERRED EMBODIMENTS

Fig.1, Fig.2, Fig.3, and **Fig.4** of the drawings and the following description depict various preferred embodiments of the present invention for purposes of illustration only. One skilled in the art will readily recognise from the following discussion those alternative embodiments of the structures and methods illustrated herein may be employed without departing from the principles of the invention described here. While the invention will be described in conjunction with the preferred embodiments, it will be understood that they are not intended to limit the invention to those embodiments. On the contrary, the invention is intended to cover alternatives, modifications, and equivalents, which may be included within the spirit and scope of the invention as defined by the claims.

Preparation of the high-permittivity calcined composition-modified barium titanate powder that is used to fabricate the EESU is explained as follows. Wet-chemical-prepared powders of high-purity as well as composition-modified barium titanate with narrow particle-size distribution have been produced with clear advantages over those prepared by solid-state reaction of mechanically mixed, ball-milled, and calcined powdered ingredients. The

compositional and particle-size uniformity attained with a coprecipitated-prepared powder is vastly superior to that with a conventional-prepared powder. The microstructures of ceramics formed from these calcined wet-chemical-prepared powders are uniform in grain size and can also result in smaller grain size. Electrical properties are improved so that higher relative permittivities and increased dielectric breakdown strengths can be obtained. Further improvement can be obtained by the elimination of voids within the sintered ceramic body with subsequent hot isostatic pressing.

High-relative-permittivity dielectrics have inherent problems, namely ageing, fatigue, degradation, and decay of the electrical properties, which limit their application. The use of surface-coated powders in which the surface region is comprised of one or two materials different in composition from that of the powder overcomes these problems provided that the compositions are appropriately chosen.

Among ceramics, alumina [aluminium oxide (Al_2O_3)], and among glasses, calcium magnesium aluminosilicate ($\text{CaO.MgO.Al}_2\text{O}_3.\text{SiO}_2$) glasses are the best dielectrics in terms of having the highest dielectric breakdown strengths and to seal the high-relative-permittivity dielectric powder particles so as to eliminate or significantly reduce their inherent problems.

A glass with a given composition at temperatures below its glass transition temperature range, which is in the neighbourhood of its strain-point temperature, is in a fully rigid condition, but at temperatures above this range is in a viscous-flow condition, its viscosity decreasing with increasing temperature. The application of hot isostatic pressing to a sintered closed-pore porous ceramic body comprised of sufficient-thickness glass-coated powder will lead to void elimination provided the glass is in the viscous-flow condition where it is easily deformable and flowable.

The wet-chemical-prepared and calcined composition-modified barium titanate powder is accordingly coated with these layers of, first, alumina, and second, a calcium magnesium aluminosilicate glass. After the first layer has been applied by wet-chemical means, the powder is calcined at 1050°C to convert the precursor, aluminium nitrate nonahydrate [$\text{Al}(\text{NO}_3)_3.9\text{H}_2\text{O}$] to aluminium oxide (corundum) [$\alpha\text{-Al}_2\text{O}_3$]. Then the second layer is applied by wet-chemical means with the use of the precursors in the appropriate amounts of each, and in absolute ethanol ($\text{CH}_3\text{CH}_2\text{OH}$) as the solvent, shown in the accompanying table. After drying, the powder is calcined at 500°C to convert the precursor mixture to a calcium magnesium aluminosilicate glass. It is important that the calcining temperature is not higher than the strain point of the selected glass composition to prevent sticking together of the powder. The glass coating has the further advantage of acting as a sintering aid and allowing a substantially lower firing temperature for densification of the ceramic body particularly during the hot-isostatic-pressing step.

Another significant advantage of the calcium magnesium aluminosilicate glass coating is that sintering and densification temperatures are sufficiently lowered to allow the use of nickel conductor electrodes in place of the conventional expensive platinum, palladium, or palladium-silver alloy ones.

Preparation of the Calcined Composition-Modified Barium Titanate Powder is Indicated by the Following Process Steps.

A solution of the precursors: $\text{Ba}(\text{NO}_3)_2$, $\text{Ca}(\text{NO}_3)_2.4\text{H}_2\text{O}$, $\text{Nd}(\text{NO}_3)_3.6\text{H}_2\text{O}$, $\text{Y}(\text{NO}_3)_3.4\text{H}_2\text{O}$, $\text{Mn}(\text{CH}_3\text{COO})_2.4\text{H}_2\text{O}$, $\text{ZrO}(\text{NO}_3)_2$, and $[\text{CH}_3\text{CH}(\text{O}-)\text{COONH}_4]_2\text{Ti}(\text{OH})_2$, as selected from the reference; Sigma-Aldrich, Corp., "Handbook of Fine Chemicals and Laboratory Equipment", 2000-2001, in de-ionised water heated to 80°C is made in the proportionate amount in weight percent for each of the seven precursors as shown in the most right-hand column of Table 3. A separate solution of $(\text{CH}_3)_4\text{NOH}$ somewhat in excess amount than required, as shown in Table 4, is made in de-ionised water, free of dissolved carbon dioxide (CO_2) and heated to $80^\circ\text{-}85^\circ\text{C}$. The two solutions are mixed by pumping the heated ingredient streams simultaneously through a coaxial fluid jet mixer. A slurry of the co-precipitated powder is produced and collected in a down-out vessel. The co-precipitated powder is refluxed in the down-out vessel at $90^\circ\text{-}95^\circ\text{C}$ for 12 hr and then filtered, de-ionised-water washed, and dried. Alternatively, the powder may be collected by centrifugal sedimentation. An advantage of $(\text{CH}_3)_4\text{NOH}$ as the strong base reactant is that there are no metal element ion residuals to wash away anyway. Any residual $(\text{CH}_3)_4\text{NOH}$, like any residual anions from the precursors, is harmless, because removal by volatilisation and decomposition occurs during the calcining step. The powder contained in a silica glass tray or tube is calcined at 1050°C in air. Alternatively, an alumina ceramic tray can be used as the container for the powder during calcining.

TABLE 2

Composition-modified barium titanate with metal element atom fractions given for an optimum result, as demonstrated in the reference: P. Hansen, U.S. Pat. No. 6,078,494, issued Jan. 20, 2000.

Composition-modified barium titanate with metal element atom fractions as follows:

Metal Element	Atom Fraction	Atomic Weight	Product	Weight %
Ba	0.9575	137.327	131.49060	98.52855
Ca	0.0400	40.078	1.60312	1.20125
Nd	0.0025	144.240	0.36060	0.27020
Total:	1.0000			100.00000
Ti	0.8150	47.867	39.01161	69.92390
Zr	0.1800	91.224	16.42032	29.43157
Mn	0.0025	54.93085	0.13733	0.24614
Y	0.0025	88.90585	0.22226	0.39839
Total:	1.0000			100.00000

TABLE 3
Watersoluble precursors and reactant strong base for wet-chemical-prepared powder of a composition-modified barium titanate by a coprecipitation procedure

Precursor	Formula	FW	Mol fraction	Product	Weight %	Multiplier factor	Product	Weight %
Barium nitrate	Ba(NO ₃) ₂	261.34	0.9575	250.233060	95.95748	1.0	95.95748	48.09898
Calcium nitrate tetrahydrate	Ca(NO ₃) ₂ ·4H ₂ O	236.15	0.0400	9.446000	3.62228	1.0	3.62228	1.81568
Neodymium nitrate hexahydrate	Nd(NO ₃) ₃ ·6H ₂ O	438.35	0.0025	1.095875	0.42024	1.0	0.42024	0.21065
Yttrium nitrate tetrahydrate	Y(NO ₃) ₃ ·4H ₂ O	346.98	0.0025	0.86746	0.30676	0.995	0.30623	0.15300
Manganese(II) acetate tetrahydrate	Mn(CH ₃ COO) ₂ ·4H ₂ O	246.08	0.0025	0.61270	0.21667	0.995	0.21559	0.10806
Oxozirconium(IV) nitrate	ZrO(NO ₃) ₂	231.23	0.1800	41.62140	14.71882	0.995	14.64523	7.34097
Bis(ammmonium lactato) dihydroxotitanium(IV)	[CH ₃ CH(O—)COONH ₄] ₂ Ti(OH) ₂	294.08	0.8150	239.67520	84.75775	0.995	84.33396	42.27266
Reactant strong base Tetramethylammonium hydroxide	(CH ₃) ₄ NOH	91.15					Total:	100.00000

TABLE 4
A - 477

Calculation of minimum amount of (CH₃)₄NOH required for 100 g of the precursor mixture

Precursor	FW	Wt %	Wt %/FW	Reactant base multiplier	Mol of base required
Ba(NO ₃) ₂	261.34	48.09898	0.184048	2	0.368095
Ca(NO ₃) ₂ ·4H ₂ O	236.15	1.81568	0.007689	2	0.015377
Nd(NO ₃) ₃ ·6H ₂ O	438.35	0.21065	0.000481	3	0.001442
Y(NO ₃) ₃ ·4H ₂ O	346.98	0.15300	0.000441	3	0.001323
Mn(CH ₃ COO) ₂ ·4H ₂ O	245.08	0.10806	0.000441	2	0.000882
ZrO(NO ₃) ₂	231.23	7.34097	0.031747	2	0.063495
[CH ₃ CH(O—)COONH ₄] ₂ Ti(OH) ₂	294.08	42.27266	0.143745	2	0.287491
	Total:	100.00000			0.738105
Reactant strong base					
(CH ₃) ₄ NOH	91.15				

Note: The weight of (CH₃)₄NOH required is accordingly a minimum of (0.738105 mol) (91.15 g/mol) = 67.278 g for 100 g of the precursor mixture. Tetramethylammonium hydroxide (CH₃)₄NOH is a strong base.

Coating of Aluminium Oxide on Calcined Modified Barium Titanate Powder

Barium titanate BaTiO ₃	FW 233.19	d 6.080 g/cm ³
Aluminium oxide Al ₂ O ₃	FW 101.96	d 3.980 g/cm ³

Precursor, aluminium nitrate nonahydrate, as selected from the reference: Sigma-Aldrich Corp., "Handbook of Fine Chemicals and Laboratory Equipment", 2000-2001. Al(NO₃)₃·9H₂O FW 375.13

For Calcined Aluminium Oxide (Al₂O₃) Coating of 100 Angstrom units Thickness on Calcined Modified Barium Titanate Powder 100 Angstrom units = 10⁻⁶ cm 1.0 m² = 104 cm²

area thickness of Al₂O₃ coating volume (10⁴ cm²/g)(10⁻⁶ cm) = 10⁻² cm³/g - - - of calcined powder

$$\frac{(10^{-2} \text{ cm}^3 \text{ volume Al}_2\text{O}_3 \text{ coating}) \times (3.98 \text{ g/cm}^3 \text{ density of Al}_2\text{O}_3)}{\text{g of calcined powder}} = \frac{39.8 \times 10^{-3} \text{ g of Al}_2\text{O}_3 \text{ coating}}{\text{g of calcined powder}} \text{ or}$$

$$= \frac{39.8 \text{ mg of Al}_2\text{O}_3 \text{ coating}}{\text{g of calcined powder}}$$

$$\text{Al(NO}_3)_3 \cdot 9\text{H}_2\text{O (FW 375.13)}(2) = 750.26$$

$$\text{Al}_2\text{O}_3 \text{ FW } 101.96 = 101.96$$

$$750.26 / 101.96 = 7.358$$

$$\frac{(7.358)(39.8 \text{ mg of Al}_2\text{O}_3 \text{ coating})}{\text{g of calcined powder}} = \frac{292.848 \text{ mg of Al(NO}_3)_3 \cdot 9\text{H}_2\text{O}}{\text{g of calcined powder}}$$

For an aluminium oxide (Al₂O₃) coating of 100 Angstrom units thickness on calcined modified barium titanate powder with particle volume of 1.0 μm³, 39.8 mg of Al₂O₃ are required per g of this powder, corresponding to 292.848 mg of the aluminium nitrate nonahydrate [Al(NO₃)₃·9H₂O] precursor required per g of this powder.

Coating of Calcium Magnesium Aluminosilicate Glass on Aluminium Oxide Coated Calcined Modified Barium Titanate Powder

	FW g/mol	d g/cm ³
Barium titanate BaTiO ₃	233.19	6.080

Calcium magnesium aluminosilicate (CaO.MgO.Al₂O₃.SiO₂) glass precursors, as selected from the reference: Sigma-Aldrich, Corp., "Handbook of Fine Chemicals and Laboratory Equipment", 2000-2001.

Calcium methoxide (CH ₃ O) ₂ Ca	101.15
Calcium isopropoxide [(CH ₃) ₂ CHO] ₂ Ca	158.25
Magnesium methoxide (CH ₃ O) ₂ Mg	86.37
Magnesium ethoxide (CH ₃ CH ₂ O) ₂ Mg	114.43
Aluminium ethoxide (CH ₃ CH ₂ O) ₃ Al	162.16
Aluminium isopropoxide [(CH ₃) ₂ CHO] ₃ Al	204.25
Aluminium butoxide [CH ₃ (CH ₂) ₃ O] ₃ Al	246.33
Tetraethyl orthosilicate Si(OCH ₂ CH ₃) ₄	208.33

Select glass composition, e.g.,

CaO.MgO.2Al₂O₃.8SiO₂ and accordingly the precursors:

1 mol	(158.25 g) calcium isopropoxide
1 mol	(114.43 g) magnesium ethoxide
4 mol	(817.00 g) aluminum isopropoxide
8 mol	(1666.64 g) tetraethyl orthosilicate

2756.32 g for 1.0 mol glass

Prepare Mixture of these Precursors in Absolute Ethanol (to Avoid Hydrolysis) and in Dry-Air Environment (Dry Box) (also to Avoid Hydrolysis).

Glass Composition: CaO.MgO.2Al₂O₃.8SiO₂ or CaMgAl₄Si₈O₂₄

1 mol (56.08 g)	CaO
1 mol (40.30 g)	MgO
2 mol (101.96 g × 2 = 203.92 g)	Al ₂ O ₃
8 mol (60.08 g × 8 = 480.64 g)	SiO ₂

glass FW total 780.98 g/mol

Density of glass: about 2.50 g/cm³

Calcined modified barium titanate powder

Particle volume: 1.0 μm³ or 1.0(10⁻⁴ cm)³ = 10⁻¹² cm³;

so there are 10¹² particles/cm³ (assumption of no voids)

Particle area: 6 μm² or (6)(10⁻⁴ cm)² = 6×10⁻⁸ cm²;

Particle area/cm³ (no voids):

(6×10⁻⁸ cm²/particle)(10¹² particles/cm³) = 6×10⁴ cm²/cm³ or 6 m²/cm³.

Then for density of 6 g/cm³, the result is:

$$\frac{6 \text{ m}^2/\text{cm}^3}{6 \text{ g/cm}^3} = 1.0 \text{ m}^2/\text{g}$$

For Calcined Glass Coating of 100 Angstrom units Thickness on Calcined Powder:

$$100 \text{ Angstrom units} = 10^{-6} \text{ cm} \quad 1.0 \text{ m}^2 = 10^4 \text{ cm}^2$$

$$(10^4 \text{ cm}^2/\text{g})(10^{-6} \text{ cm}) = 10^{-2} \text{ cm}^3/\text{g} \text{ of calcined powder of glass coating and then}$$

$$\frac{(10^{-2} \text{ cm}^3 \text{ of glass coating})}{\text{g of calcined powder}} \times (2.50 \text{ g/cm}^3 \text{ density of glass}) =$$

$$\frac{25.0 \times 10^{-3} \text{ g of glass coating}}{\text{g of calcined powder}} \quad \text{or} \quad \frac{25.0 \text{ mg of glass coating}}{\text{g of calcined powder}}$$

Precursor mixture FW 2756.32 = 3.529

Glass FW 780.98

$$\frac{(3.529)(25.0 \text{ mg of glass coating})}{(\text{g of calcined powder})} = 88.228 \text{ mg of precursor mixture}$$

For a $\text{CaMgAl}_4\text{Si}_8\text{O}_{24}$ glass coating of 100 Angstrom units thickness on calcined modified barium titanate powder with particle volume of $1.0 \mu\text{m}^3$, 25.0 mg of this glass are required per g of this powder, corresponding to 88.228 mg of the precursor mixture required per g of this powder.

Particle Volume and Area

$$V \text{ particle} = a^3 \text{ for cube}$$

$$\text{If } a = 1.0 \mu\text{m}, V = 1.0 \mu\text{m}^3$$

$$A \text{ particle} = 6a^2 \text{ for cube}$$

$$\text{If } a = 1.0 \mu\text{m}, A = 6 \mu\text{m}^2$$

Particle coating volume

$$(6 a^2)(t), \text{ if } t = 100 \text{ Angstrom units} = 10 \times 10^{-3} \mu\text{m}, \text{ and } 6 a^2 = 6.0 \mu\text{m}^2, \\ \text{then } (6.082 \text{ m}^2)(10 \times 10^{-3} \mu\text{m}) = 60 \times 10^{-3} \mu\text{m}^3 = V \text{ coating}$$

$$\text{Ratio of particle coating volume to particle volume } 60 \times 10^{-3} \mu\text{m}^3 / 1.0 \mu\text{m}^3 = 60 \times 10^{-3} = 0.06 \text{ or } 6\%$$

With the assumption of no voids and absolutely smooth surface, for an ideal cubic particle with volume of $1.0 \mu\text{m}^3$ and for a particle coating of 100 Angstrom units thickness, the coating volume is $60 \times 10^{-3} \mu\text{m}^3$ or 6.0% that of the particle volume.

Calculations of the Electrical-Energy-Storage Unit's Weight, Stored Energy, Volume, and Configuration.

Assumptions:

The relative permittivity of the high-permittivity powder is nominally 33,500, as given in the reference: P. Hansen, U.S. Pat. No. 6,078,494, issued Jan. 20, 2000.

* The 100 ? coating of Al_2O_3 and 100 ? of calcium magnesium aluminosilicate glass will reduce the relative permittivity by 12%.

* $K = 29,480$

$$\text{Energy stored by a capacitor: } E = CV^2 / (2 \times 3600 \text{ s/h}) = W \cdot h$$

* $C =$ capacitance in farads

* $V =$ voltage across the terminals of the capacitor

It is estimated that it takes 14 hp, 746 watts per hp, to power an electric vehicle running at 60 mph with the lights, radio, and air conditioning on. The energy-storage unit must supply 52,220 W·h or 10,444 W for 5 hours to sustain this speed and energy usage and during this period the EV will have travelled 300 miles. Each energy-storage component has 1000 layers.

$$C = \epsilon_0 K A / t$$

- * ϵ_0 = permittivity of free space
- * K = relative permittivity of the material
- * A = area of the energy-storage component layers
- * t = thickness of the energy-storage component layers

Voltage breakdown of the energy-storage components material after coating with Al_2O_3 and calcium magnesium aluminosilicate glass will be in the range of 1.0×10^6 V/cm to 5×10^6 V/cm or higher. Using the proper voltage breakdown selected from this range could allow the voltage of the energy-storage unit to be 3500 V or higher.

One hp = 746 W

EXAMPLE

Capacitance of one layer = $8.854 \times 10^{-12} \text{ F/m} \times 2.948 \times 10^4 \times 6.45 \times 10^{-4} \text{ m}^2 / 12.7 \times 10^{-6} \text{ m}$

$C = 0.000013235 \text{ F}$

With 1000 layers:

$C = 0.013235 \text{ F}$

The required energy storage is

$$E_t = 14 \text{ hp} \times 746 \text{ W/hp} \times 5 \text{ h} = 52,220 \text{ W}\cdot\text{h}$$

The total required capacitance of the energy-storage unit:

$$C_T = E_t \times 2 \times 3600 \text{ s/h} / V^2 = 52,220 \text{ W}\cdot\text{h} \times 2 \times 3600 \text{ s/h} / (3500 \text{ V})^2 \quad C_T = 31 \text{ F}$$

Number of capacitance components required:

$$N_c = 31 \text{ F} / 0.013235 \text{ F} = 2320$$

Volume and weight of energy-storage unit:

Volume of the dielectric material:

$$\begin{aligned} \text{Volume} &= \text{area} \times \text{thickness} \times \text{number of layers} \\ &= 6.45 \text{ cm}^2 \times 12.72 \times 10^{-4} \text{ cm} \times 1000 \\ &= 8.2 \text{ cm}^3 \end{aligned}$$

Total volume = $8.2 \text{ cm}^3 \times \text{number of components (2320)} = 19,024 \text{ cm}^3$

Density of the dielectric material = 6.5 g/cm^3

Weight of each component = density \times volume = 53.3 g

Total weight of the dielectric material = $53.3 \text{ g} \times 2320 / 454 \text{ g per pound} = 272 \text{ pounds}$

Volume of the nickel conductor layers:

Thickness of the nickel layer is $1 \times 10^{-6} \text{ m}$

Volume of each layer = $6.45 \text{ cm}^2 \times 1.0 \times 10^{-4} \text{ cm} \times 1000 = 0.645 \text{ cm}^3$

Density of nickel = 8.902 g/cm^3

Weight of nickel layers for each component = 5.742 g

Total weight of nickel = 34 pounds

Total number of capacitance layers and volume of the EESU:

Area required for each component to solder bump = 1.1 inch^2

A 12×12 array will allow 144 components for each layer of the first array

19 layers of the second array will provide 2736 components which are more than enough to meet the required 2320 components. The distance between the components will be adjusted so that 2320 components will be in each EESU. The second array area will remain the same.

The total weight of the EESU (est.) = 336 pounds

The total volume of the EESU (est.) = $13.5 \text{ inches} \times 13.5 \text{ inches} \times 11 \text{ inches} = 2005 \text{ inches}^3$ which includes the weight of the container and connecting material.

The total stored energy of the EESU = 52,220 W·h

From the above description, it will be apparent that the invention disclosed herein provides a novel and advantageous electrical-energy-storage unit composed of unique materials and processes. The foregoing discussion discloses and describes merely exemplary methods and embodiments of the present invention. As will be understood by those familiar with the art, the invention may be embodied in other specific forms and utilise other materials without departing from the spirit or essential characteristics thereof. Accordingly, the disclosure of the present invention is intended to be illustrative, but not limiting, of the scope of the invention, which is set forth in the following claims.

CLAIMS

- 1.** A method for making an electrical-energy-storage unit comprising components fabricated by the method steps as follow;
 - a)** preparing a wet-chemical-prepared calcined composition-modified barium titanate powder derived from a solution of precursors: $\text{Ba}(\text{NO}_3)_2$, $\text{Ca}(\text{NO}_3)_2 \cdot 4\text{H}_2\text{O}$, $\text{Nd}(\text{NO}_3)_3 \cdot 6\text{H}_2\text{O}$, $\text{Y}(\text{NO}_3)_3 \cdot 4\text{H}_2\text{O}$, $\text{Mn}(\text{CH}_3\text{COO})_2 \cdot 4\text{H}_2\text{O}$, $\text{ZrO}(\text{N}_3\text{O})_2$, and $[\text{CH}_3\text{CH}(\text{O}-)\text{COONH}_4]_2\text{Ti}(\text{OH})_2$ in de-ionised water heated to 80°C , and a separate solution of $(\text{CH}_3)_4\text{NOH}$ made in de-ionised water and heated to $80^\circ\text{-}85^\circ\text{C}$, then mixing the solutions by pumping the heated ingredient streams simultaneously through a coaxial fluid mixer producing co-precipitated powder, then collecting the co-precipitated powder in a drown-out vessel and refluxing at a temperature of $90^\circ\text{-}95^\circ\text{C}$ for 12 hours, then filtering, washing with de-ionised water, drying, and then calcining 1050°C in air;
 - b)** fabricating an aluminium oxide (Al_2O_3) coating of 100 Angstrom units thickness on to the wet-chemical-prepared calcined composition-modified barium titanate powder, with the use of aluminium nitrate nonahydrate precursor applied by wet chemical means, then calcining at 1050°C , resulting in a single-coated calcined composition-modified barium titanate powder;
 - c)** fabricating on to the alumina-coated composition-modified barium titanate powder, a second uniform coating of 100 Angstrom units of calcium magnesium aluminosilicate glass derived from alcohol-soluble precursors: calcium methoxide or calcium isopropoxide, magnesium methoxide or magnesium ethoxide, aluminium ethoxide or aluminium isopropoxide or aluminium isopropoxide, and tetraethyl orthosilicate are applied by wet chemical means which upon calcining at 500°C results in a double-coated composition-modified barium titanate powder;
 - d)** blending, this double-coated composition-modified barium titanate powder with a screen-printing ink containing appropriate plastic resins surfactants, lubricants, and solvents to provide a suitable rheology for screen printing;
 - e)** screen-printing into interleaved multi-layers of alternating offset nickel electrode layers **12** and double-coated calcined composition-modified barium titanate high-relative-permittivity layers **11** with the use of screening inks having the proper rheology for each of the layers;
 - f)** drying and cutting the screen-punted multi-layer components **15** into a specified rectangular area;
 - g)** sintering the screen-printed multi-layer components **15**, first at a temperature of 350°C for a specified length of time, then at 850°C for a specified length of time, to form closed-pore porous ceramic bodies; and
 - h)** hot isostatically pressing the closed-pore porous ceramic bodies, at a temperature of 700°C with a specified pressure, into a void-free condition;
 - i)** grinding and each side of the component to expose the alternating offset interleaved nickel electrodes **12**;
 - j)** connecting nickel side bars **14** to each side of the components **15**, that have the interleaved and alternating offset nickel electrodes **12** exposed, by applying nickel ink with the proper rheology to each side and clamping the combinations together;
 - k)** heating the components and side nickel bar combination **14-15** 800°C , and time duration of 20 minutes to bond them together;
 - l)** wave soldering each side of the conducting bars;
 - m)** assembling the components **15** with the connected nickel side bars **14** into the first array, utilising unique tooling and solder-bump technology;

- n) assembling the first arrays into the second array;
 - o) assembling the second arrays into the EESU final assembly.
2. The method of claim 1 wherein a second coating of glass is provided on to the double-coated composition-modified barium titanate powder being in contact with the nickel electrodes and having an applied working voltage of 3500 V across the parallel electrodes.
 3. The method of claim 1 wherein a dielectric voltage breakdown strength of 5.0×10^6 V/cm was achieved across the electrodes of the components.
 4. The method of claim 1 wherein the method provides an ease of manufacturing due to the softening temperature of the calcium magnesium aluminosilicate glass allowing the relatively low hot-isostatic-pressing temperatures of 700°C which in turn provides a void-free ceramic body.
 5. The method of claim 1 wherein the method provides an ease of fabrication due to the softening temperature of the calcium magnesium aluminosilicate glass allowing the relatively low hot-isostatic-pressing temperatures of 700°C which in turn allows the use of nickel for the conduction-path electrodes rather than expensive platinum, palladium, or palladium-silver alloy.
 6. The method of claim 1 wherein the method provides an ease of fabrication due to the softening temperature of the calcium magnesium aluminosilicate glass allowing the relatively low hot-isostatic-pressing temperatures of 700°C, which feature along with the coating method provided a uniform-thickness shell of the calcium magnesium aluminosilicate glass and in turn provides hot-isostatic-pressed double-coated composition-modified barium titanate high-relative-permittivity layers that are uniform and homogeneous in microstructure.
 7. The method of claim 1 wherein the method provides the double coating of the basis particles of the composition-modified barium titanate powder thereby reducing the leakage and ageing of this material by an order of magnitude of the specification of this basis material, thus reducing the discharge rate to 0.1% per 30 days.
 8. The method of claim 1 wherein the method provides a double coating of the composition-modified barium titanate powder, the hot-isostatic-pressing process, the high-density solder-bump packaging, and along with the double-layered array configuration stored 52,220 W·h of electrical energy in a 2005 inches³ container.
 9. The method of claim 1 wherein the method provides materials used: water-soluble precursors of barium (Ba), calcium (Ca), titanium (Ti), zirconium (Zr), manganese (Mn), yttrium (Y), neodymium (Nd), forming the composition-modified barium titanate powder, and the metals: nickel (Ni), and copper (Cu), which are not explosive, corrosive, or hazardous.
 10. The method of claim 1 wherein the method provides an EESU that is not explosive, corrosive, or hazardous and therefore is a safe product when used in electrical vehicles, which include bicycles, tractors, buses, cars, or any device used for transportation or to perform work.
 11. The method of claim 1 wherein the method provides an EESU which can store electrical energy generated from solar voltaic cells or other alternative sources for residential, commercial, or industrial applications.
 12. The method of claim 1 wherein the method provides an EESU which can store electrical energy from the present utility grid during the night when the demand for electrical power is low and then deliver the electrical energy during the peak power demand times and thus provide an effective power averaging function.
 13. The method of claim 1 wherein the method provides a double coating of the composition-modified barium titanate powder and a hot-isostatic-pressing process which together assists in allowing an applied voltage of 3500 V to a dielectric thickness of 12.76×10^{-6} m to be achieved.
 14. The method of claim 1 wherein the method provides a EESU which when fully discharged and recharged, the EESU's initial specifications are not degraded.
 15. The method of claim 1 wherein the method provides a EESU which can be safely charged to 3500 V and store at least 52.22 kW·h of electrical energy.
 16. The method of claim 1 wherein the method provides a EESU at has a total capacitance of at least 31 F.

17. The method of claim 1 wherein the method provides a EESU that can be rapidly charged without damaging the material or reducing its life.

HERMANN PLAUSON

US Patent 1,540,998

9th June 1925

Inventor: Hermann Plauson

CONVERSION OF ATMOSPHERIC ELECTRIC ENERGY

Please note that this is a re-worded excerpt from this patent. It describes in considerable detail, different methods for abstracting useable electrical power from passive aerial systems. He describes a system with 100 kilowatt output as a "small" system.

Be it known that I, Hermann Plauson, Estonian subject, residing in Hamburg, Germany, have invented certain new and useful improvements in the Conversion of atmospheric Electric Energy, of which the following is a specification.

According to this invention, charges of atmospheric electricity are not directly converted into mechanical energy, and this forms the main difference from previous inventions, but the static electricity which runs to earth through aerial conductors in the form of direct current of very high voltage and low current strength is converted into electro-dynamic energy in the form of high frequency vibrations. Many advantages are thereby obtained and all disadvantages avoided.

The very high voltage of static electricity of a low current strength can be converted by this invention to voltages more suitable for technical purposes and of greater current strength. By the use of closed oscillatory circuits it is possible to obtain electromagnetic waves of various amplitudes and thereby to increase the degree of resonance of such current. Such resonance allows various values of inductance to be chosen which, by tuning the resonance between a motor and the transformer circuit, allows the control of machines driven by this system. Further, such currents have the property of being directly available for various uses, other than driving motors, including lighting, heating and use in electro-chemistry.

Further, with such currents, a series of apparatus may be fed without a direct current supply through conductors and the electro-magnetic high frequency currents may be converted by means of special motors, adapted for electro-magnetic oscillations, into alternating current of low frequency or even into high voltage direct current.

DESCRIPTION OF THE DRAWINGS

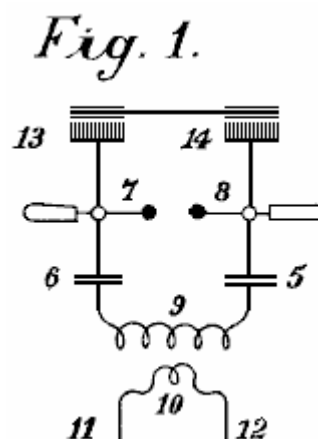

Fig.1 is an explanatory figure

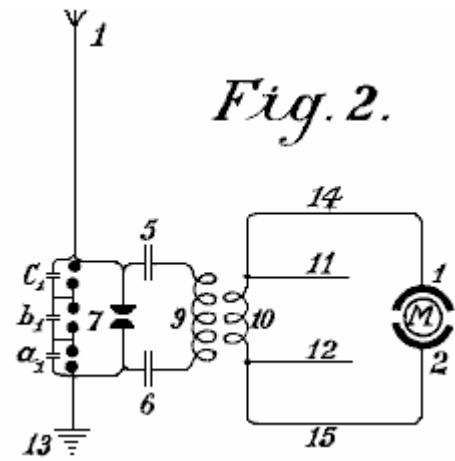

Fig.2 is a diagrammatic view of the most simple form.

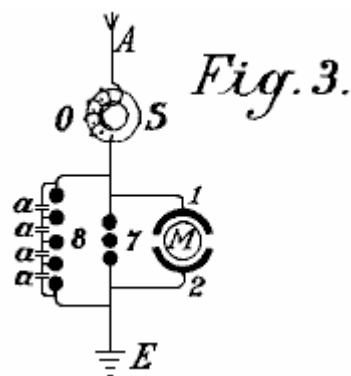

Fig.3 shows a method of converting atmospheric electrical energy into a form suitable for use with motors.

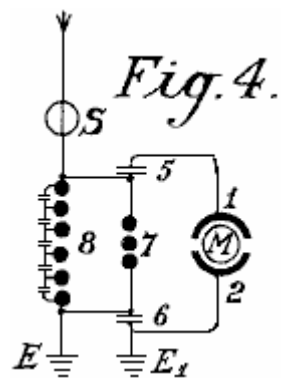

Fig.4 is a diagram showing the protective circuitry.

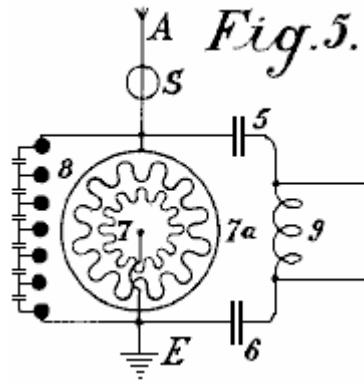

Fig.5 is a diagram of an arrangement for providing control

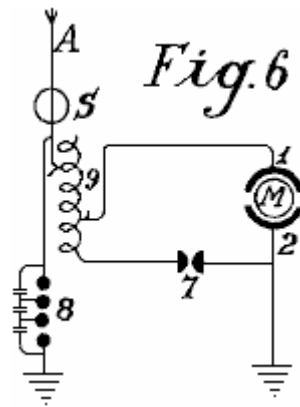

Fig.6 is an arrangement including a method of control

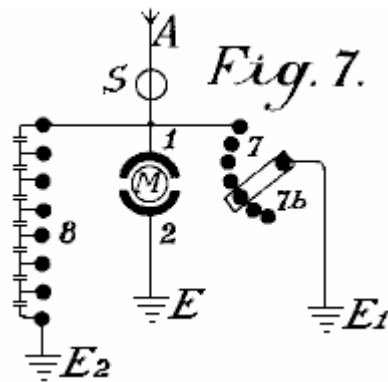

Fig.7 shows how the spark gap can be adjusted

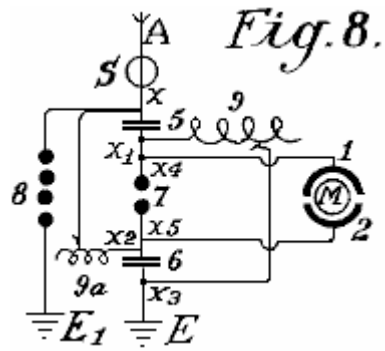

Fig.8 shows a unipolar connection for the motor

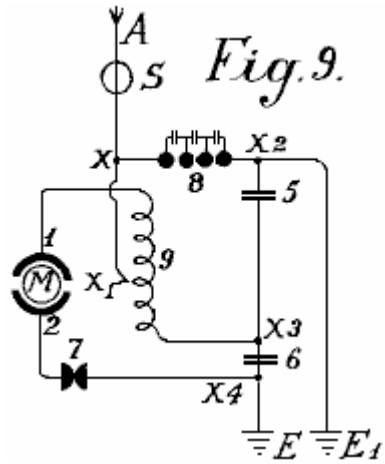

Fig.9 shows a weak coupled system suitable for use with small power motors

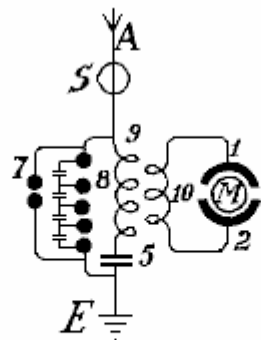
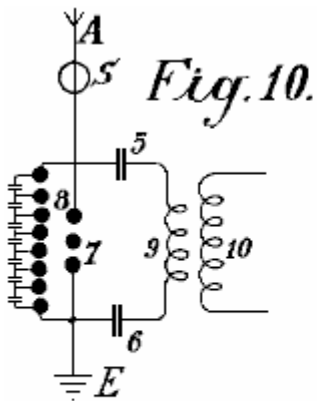

Fig.11.

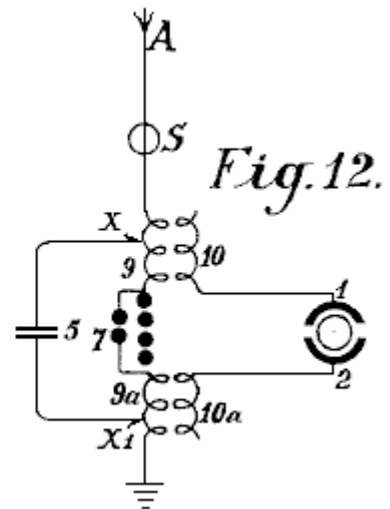

Fig.10, Fig.11 and Fig.12 show modified arrangements

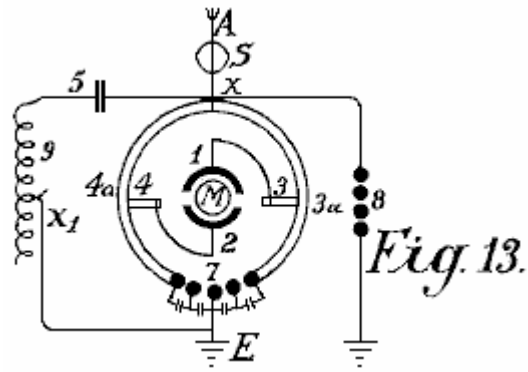

Fig.13 shows a form of inductive coupling for the motor circuit

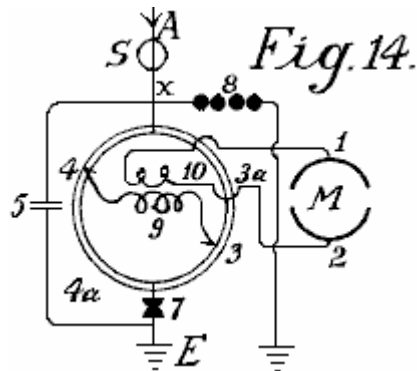

Fig.14 is a modified form of Fig.13 with inductive coupling.

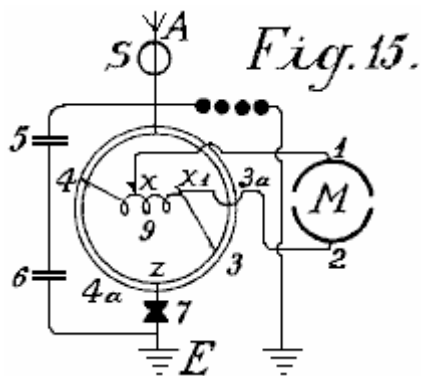

Fig.15 is an arrangement with non-inductive motor

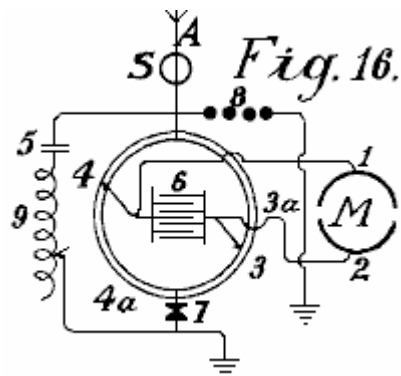

Fig.16 is an arrangement with coupling by capacitor.

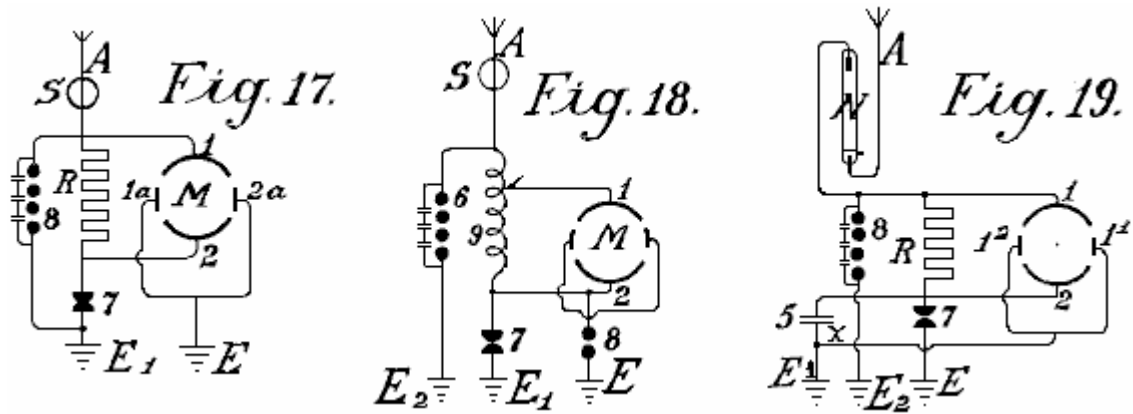

Fig.17, Fig.18 and Fig.19 are diagrams showing further modifications

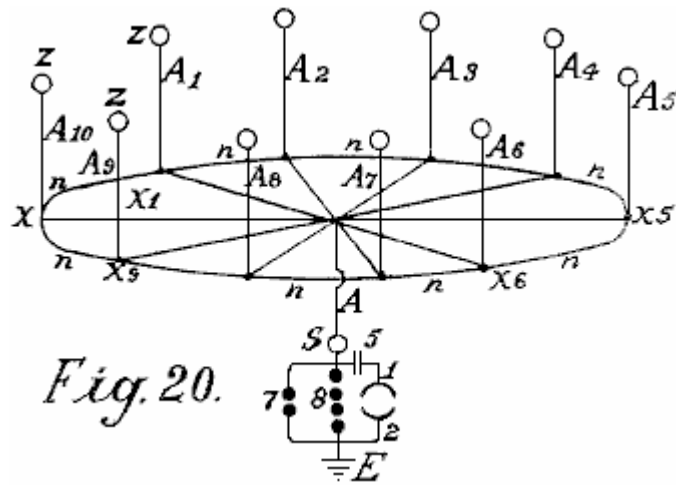

Fig.20 shows a simple form in which the aerial network is combined with special collectors

Fig. 21.

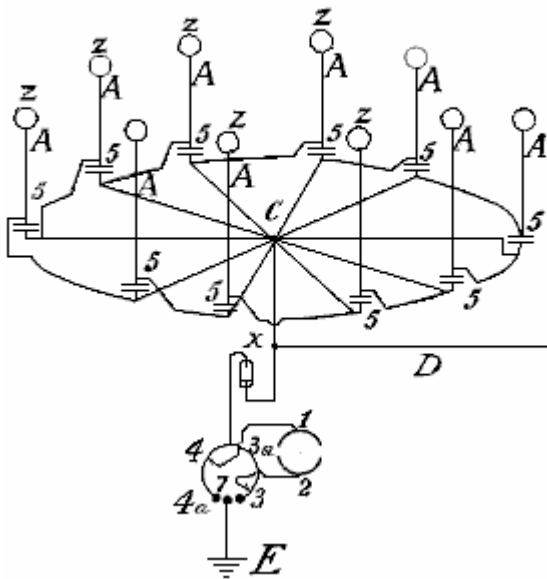

Fig. 22.

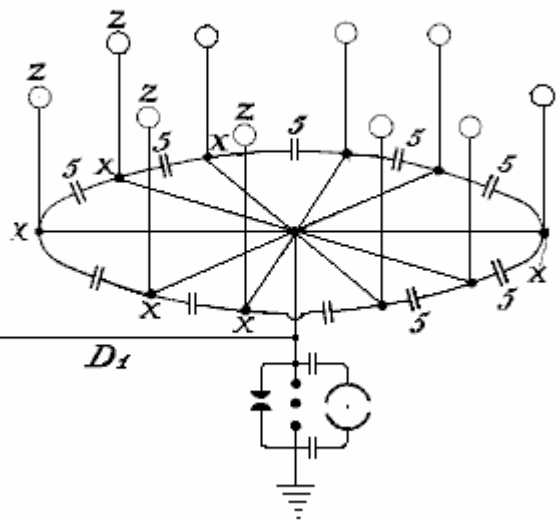

Fig.21 shows diagrammatically, an arrangement suitable for collecting large quantities of energy.
Fig.22 is a modified arrangement having two rings of collectors

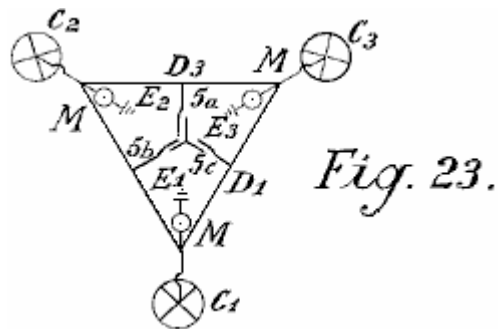

Fig.23 shows the connections for three rings of collectors

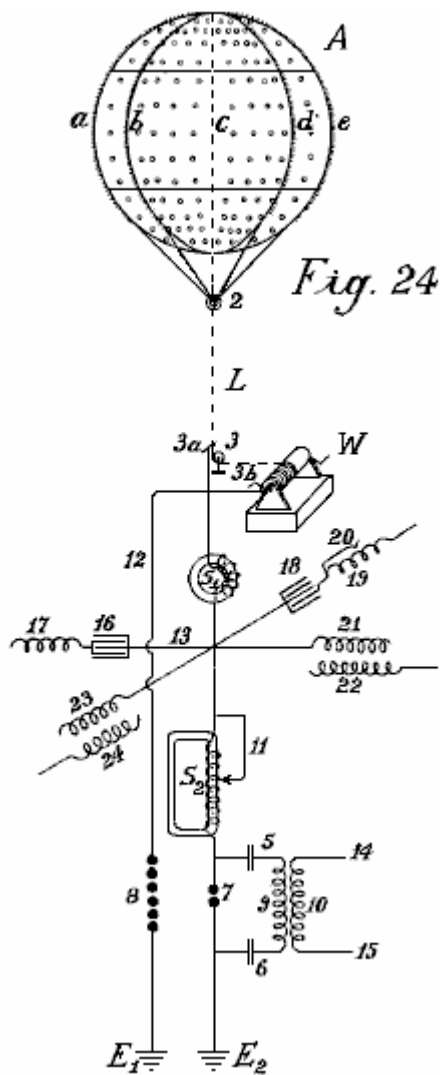

Fig.24 shows a collecting balloon and diagram of its battery of capacitors

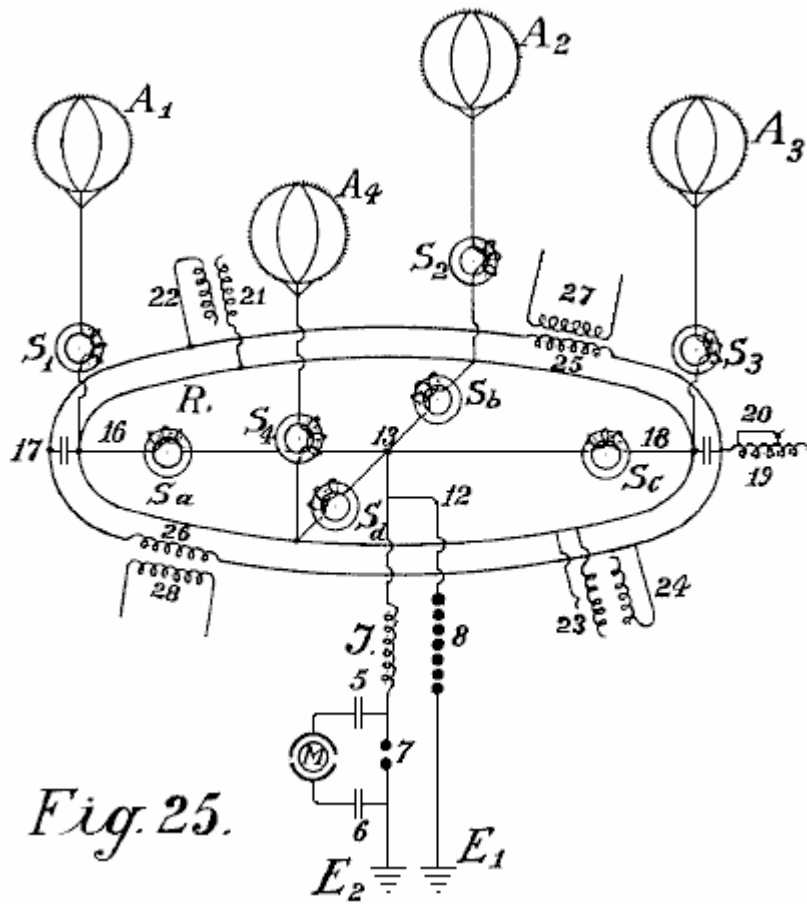

Fig.25 and Fig.26 show modified collector balloon arrangements.

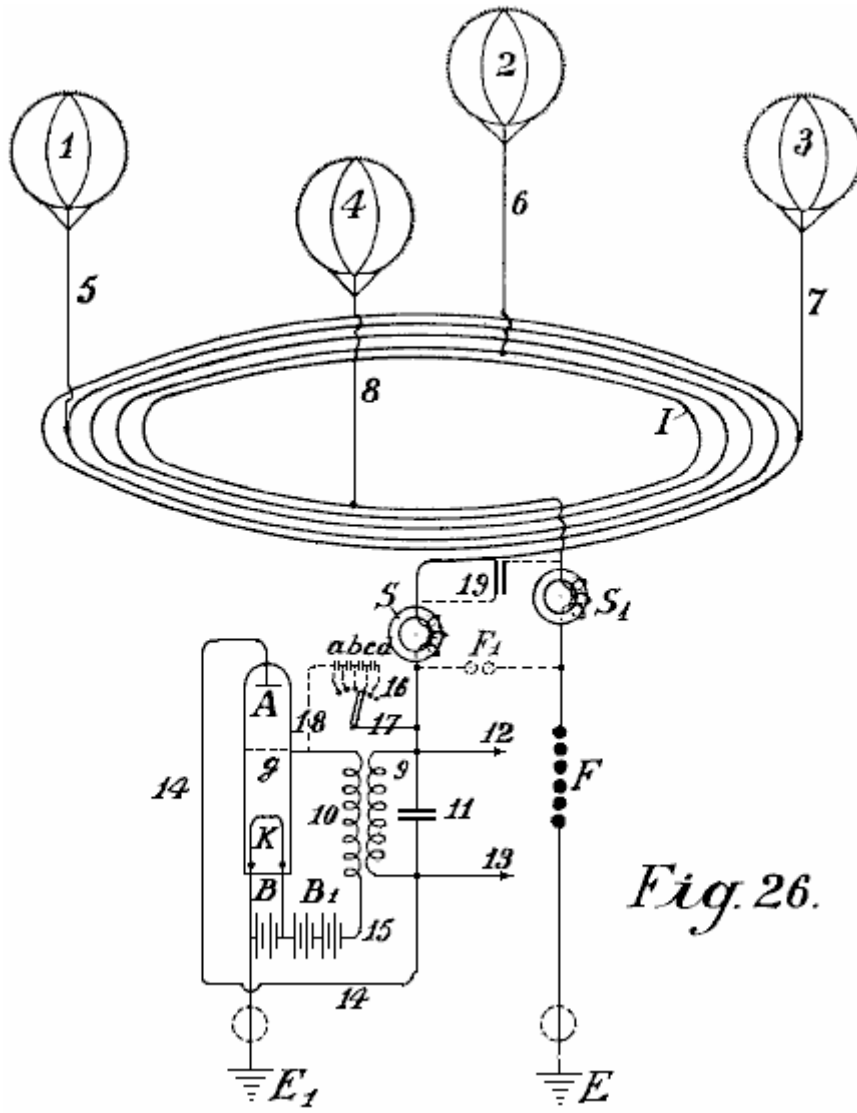

Fig. 26.

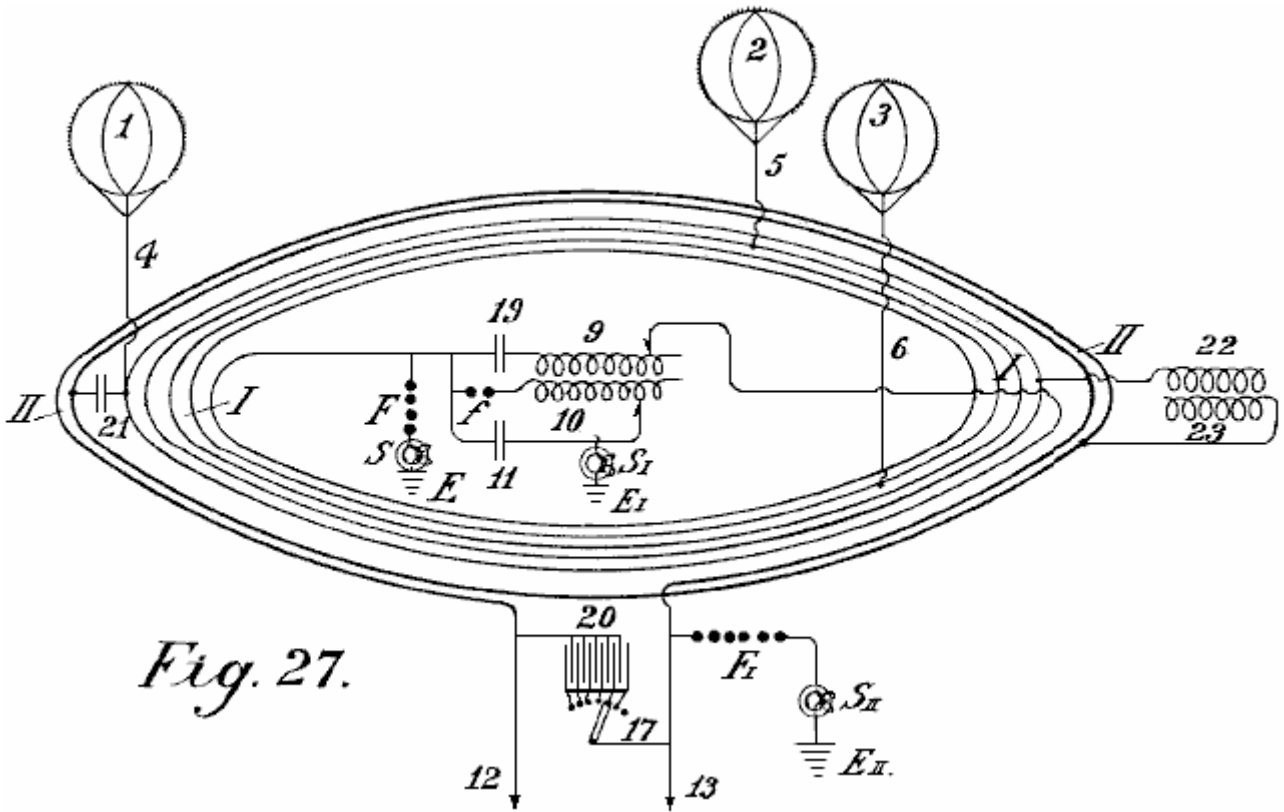

Fig.27 shows a second method of connecting conductors for the balloon aerials.

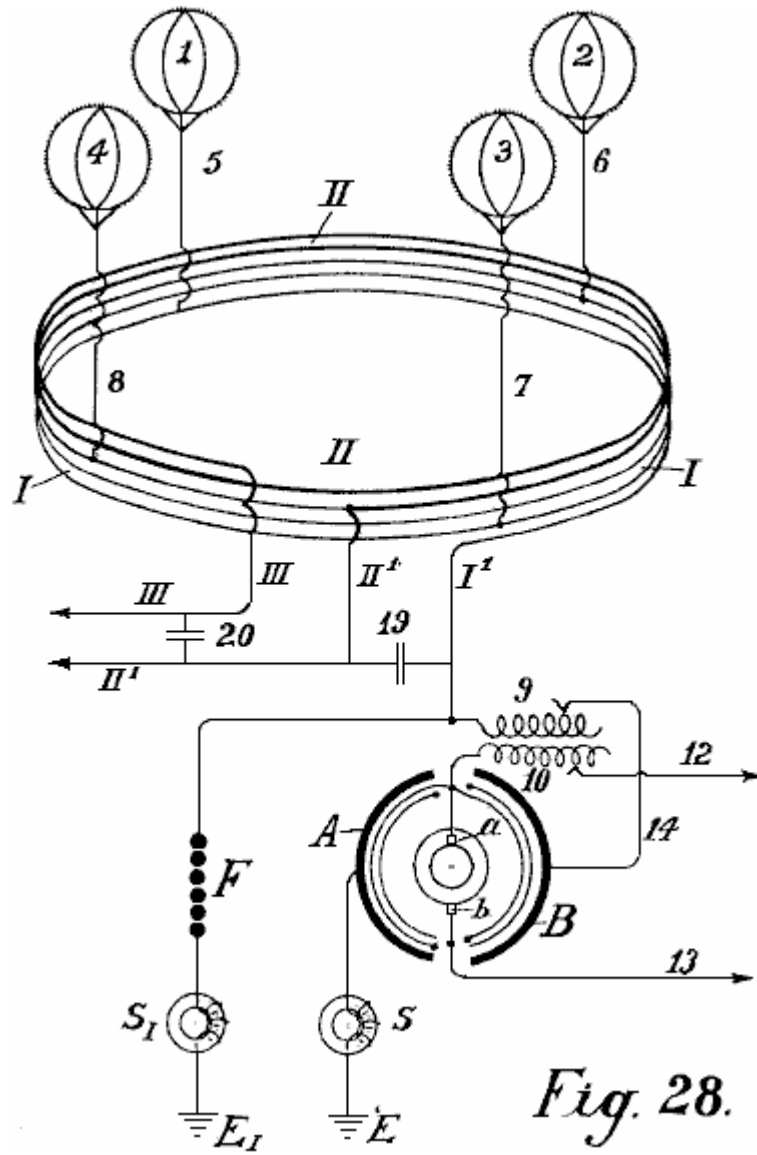

Fig. 28.

Fig.28 shows an auto-transformer method of connection.

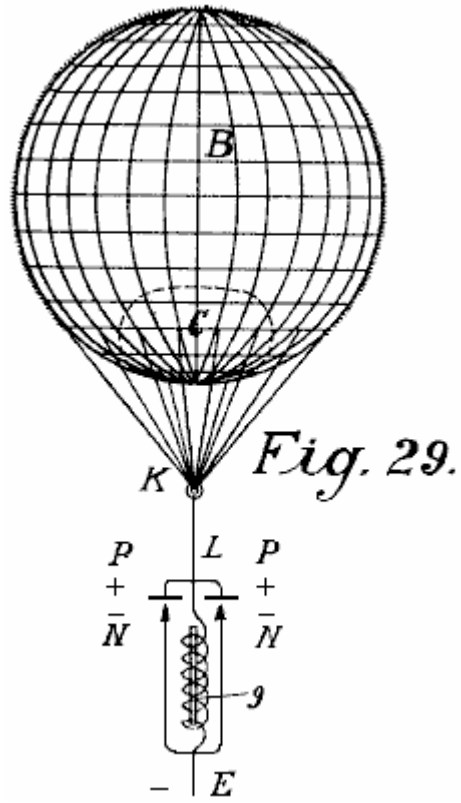

Fig.29 shows the simplest form of construction with incandescent cathode.

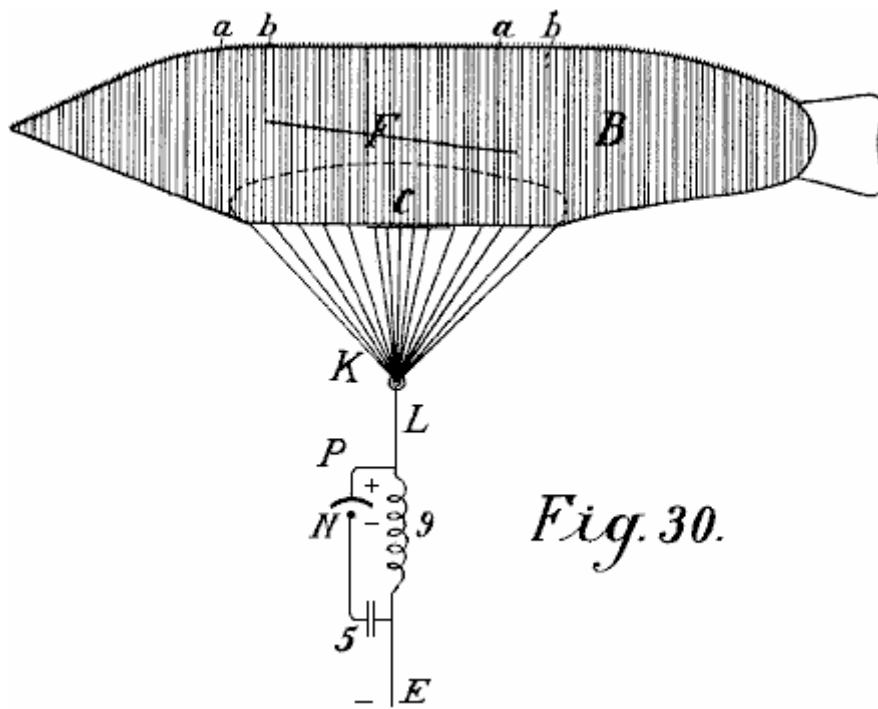

Fig.30 shows a form with a cigar-shaped balloon.

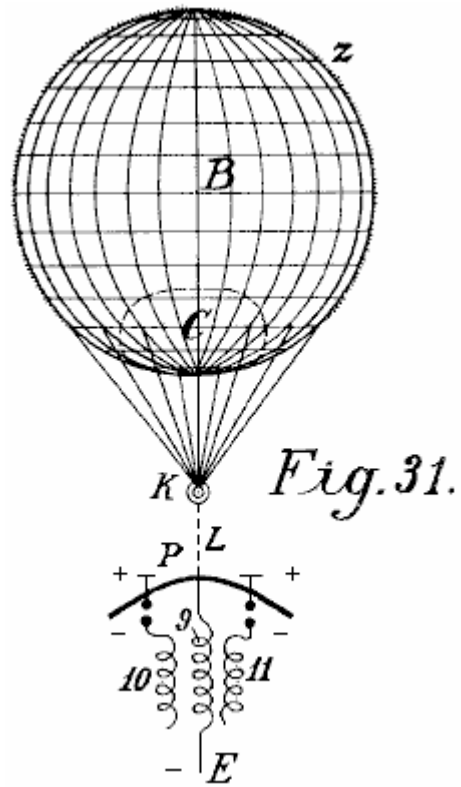

Fig.31 is a modified arrangement.

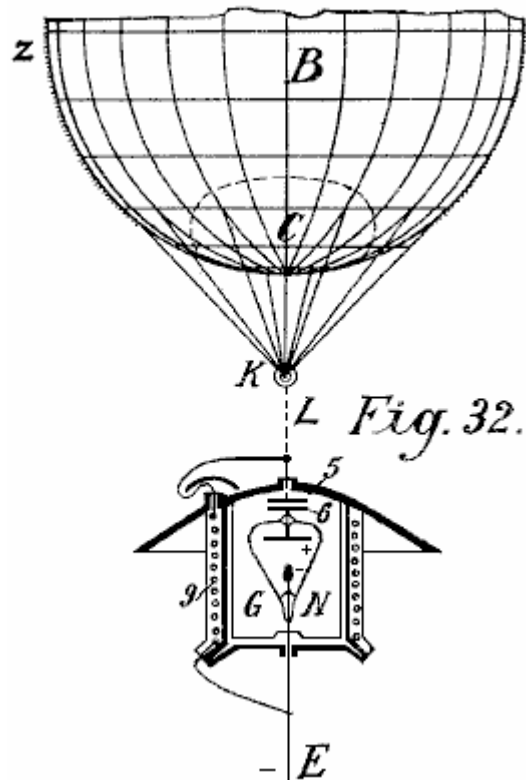

Fig.32 shows a form with cathode and electrode enclosed in a vacuum chamber.

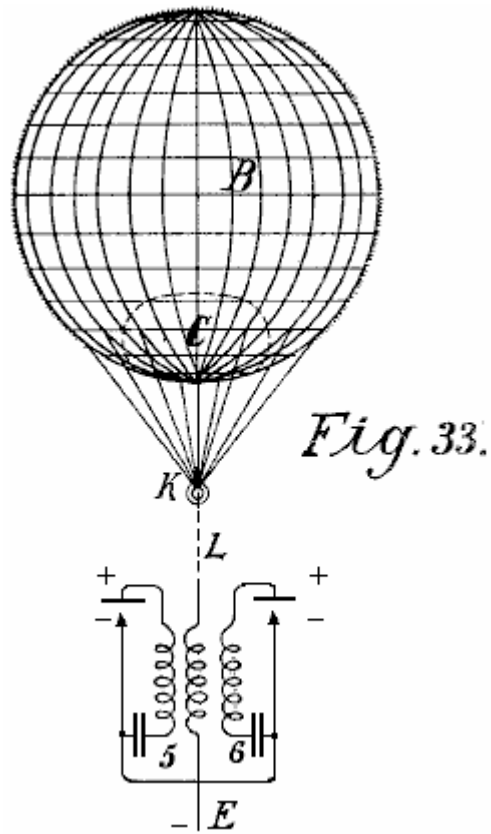

Fig.33 is a modified form of Fig.32

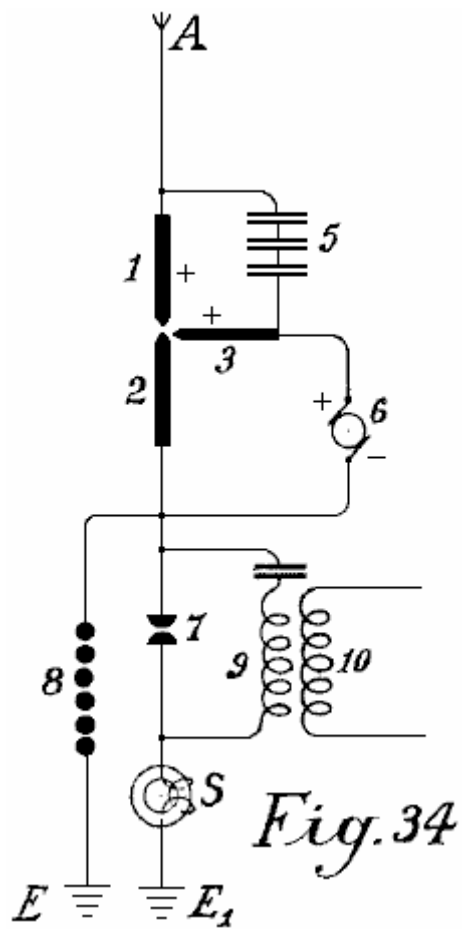

Fig.34 shows an arc light collector.

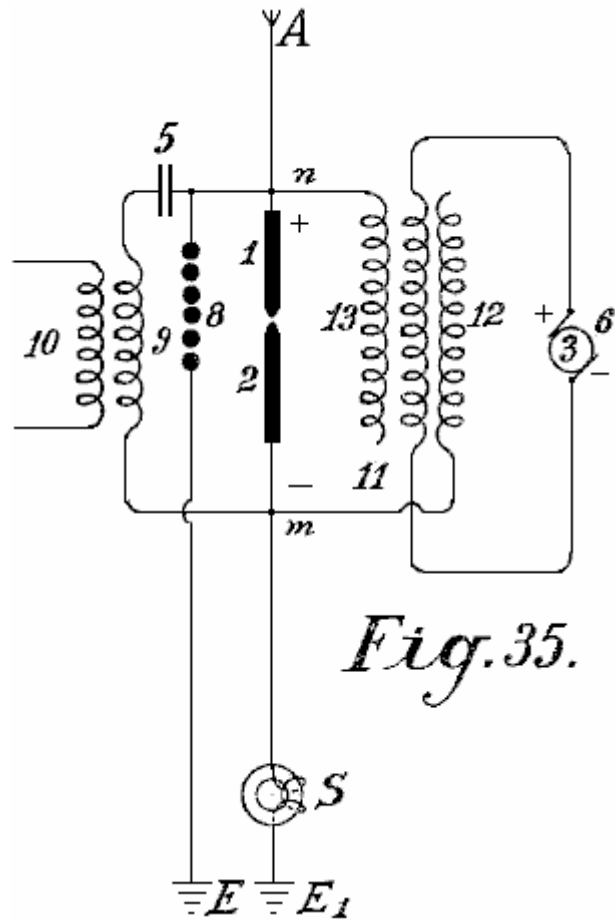

Fig.35.

Fig.35 shows such an arrangement for alternating current

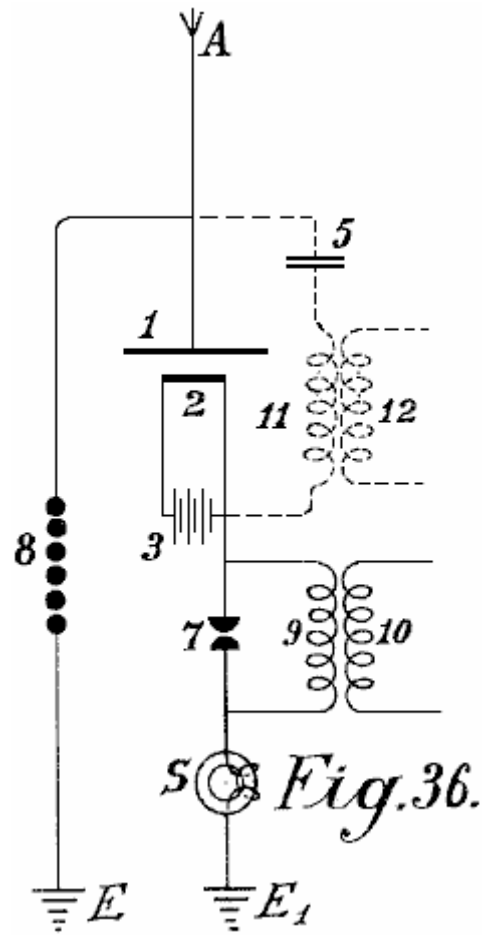

Fig.36 shows an incandescent collector with Nernst lamp

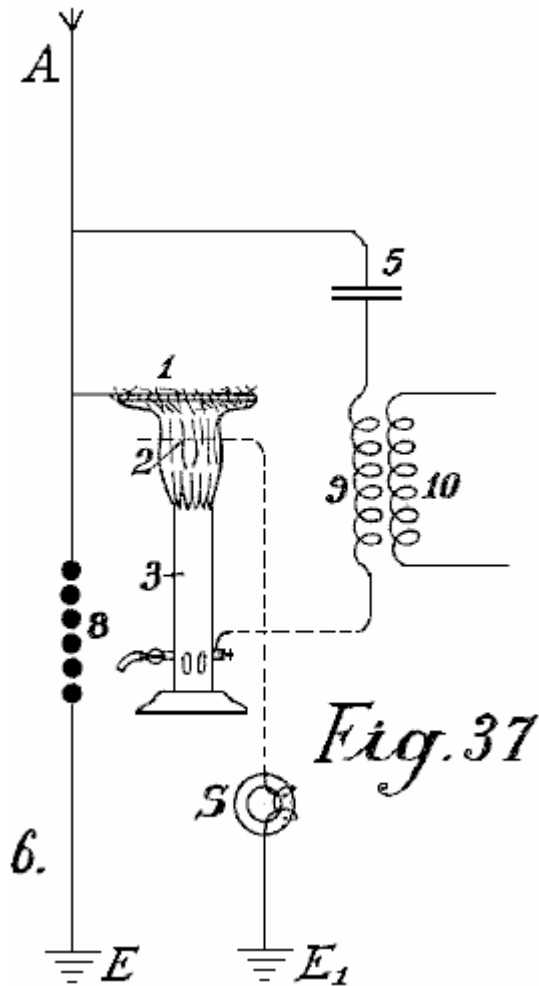

Fig.37 shows a form with a gas flame.

Fig. 1.

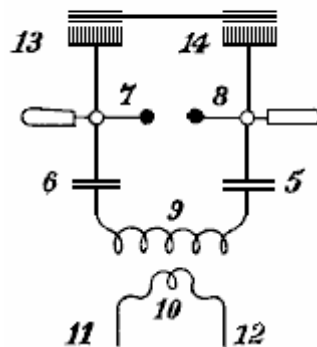
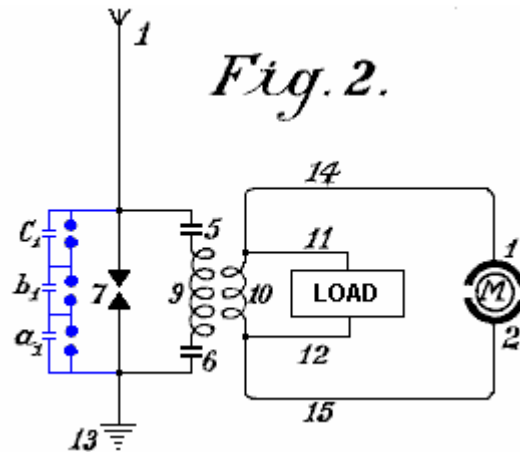

Fig.1 illustrates a simple diagram for converting static electricity into dynamic energy of a high number of oscillations. For the sake of clarity, a Wimshurst machine is assumed to be employed and not an aerial antenna. Items **13** and **14** are combs for collecting the static electricity of the influence machine. Items **7** and **8** are spark-discharging electrodes. Items **5** and **6** are capacitors, **9** is the primary winding of an inductive coil, **10** is the secondary winding whose ends are **11** and **12**. When the disc of the static influence machine is rotated by mechanical means, the combs collect the electric charges, one being positive and one negative and these charge the capacitors **5** and **6** until such a high voltage is developed across the spark gap **7-- 8** that the spark gap is jumped. As the spark gap forms a closed circuit with capacitors **5** and **6**, and inductive resistance **9**, as is well known, waves of high frequency electromagnetic oscillations will pass in this circuit.

The high frequency of the oscillations produced in the primary circuit induces waves of the same frequency in the secondary circuit. Thus, in the primary circuit, electromagnetic oscillations are formed by the spark and these oscillations are maintained by fresh charges of static electricity.

By suitably selecting the ratio between the number of turns in the primary and secondary windings, with regard to a correct application of the coefficients of resonance (capacitance, inductance and resistance) the high voltage of the primary circuit may be suitably converted into a low voltage high current output.

When the oscillatory discharges in the primary circuit become weaker or cease entirely, the capacitors are charged again by the static electricity until the accumulated charge again breaks down across the spark gap. All this is repeated as long as electricity is produced by the static machine through the application of mechanical energy to it.



An elementary form of the invention is shown in **Fig.2** in which two spark gaps in parallel are used, one of which may be termed the working gap **7** while the second serves as a safety device for excess voltage and consists of a larger number of spark gaps than the working section, the gaps being arranged in series and which are bridged by very small capacitors a_1, b_1, c_1 , which allow uniform sparking in the safety section.

1 is the aerial antenna for collecting charges of atmospheric electricity, **13** is the earth connection of the second part of the spark gap, **5** and **6** are capacitors and **9** is the primary coil winding. When the positive atmospheric electricity seeks to combine with the negative earth charge via aerial **1**, this is prevented by the air gap between the spark gaps. The resistance of spark gap **7** is lower than that of the safety spark gap set of three spark gaps connected in series a which consequently has three times greater air resistance.

Therefore, so long as the resistance of spark gap **7** is not overloaded, discharges take place only through it. However, if the voltage is increased by any influence to such a level that it might be dangerous for charging the capacitors **5** and **6**, or for the coil insulation of windings **9** and **10**, the safety spark gap set will, if correctly set, discharge the voltage directly to earth without endangering the machine. Without this second spark gap arrangement, it is impossible to collect and render available large quantities of electrical energy.

The action of this closed oscillation circuit consisting of spark gap **7**, two capacitors **5** and **6**, primary coil **9** and secondary coil **10**, is exactly the same as that of **Fig.1** which uses a Wimshurst machine, the only difference being the provision of the safety spark gap. The high frequency electromagnetic alternating current can be tapped off through the conductors **11** and **12** for lighting and heating purposes. Special motors adapted for working with static electricity or high frequency oscillations may be connected at **14** and **15**.

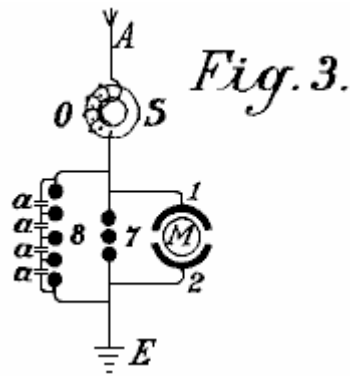

In addition to the use of spark gaps in parallel, a second measure of security is also necessary for taking the current from this circuit. This is the introduction of protective electromagnets or choking coils in the aerial circuit as shown by **S** in **Fig.3**. A single electromagnet having a core of the thinnest possible separate laminations is connected with the aerial. In the case of high voltages in the aerial network or at places where there are frequent thunderstorms, several such magnets may be connected in series.

In the case of large units, several such magnets can be employed in parallel or in series parallel. The windings of these electromagnets may be simply connected in series with the aerials. In this case, the winding preferably consists of several thin parallel wires, which together, make up the necessary cross-sectional area of wire. The winding may be made of primary and secondary windings in the form of a transformer. The primary winding will then be connected in series with the aerial network, and the secondary winding more or less short-circuited through a regulating resistor or an induction coil. In the latter case it is possible to regulate, to a certain extent, the effect of the choking coils. In the following circuit and constructional diagrams, the aerial electromagnet choke coil is indicated by a simple ring **S**.

Fig.3 shows the most simple way of converting atmospheric electricity into electromagnetic wave energy by the use of special motors adapted for high oscillatory currents or static charges of electrical energy. Recent improvements in motors for working with static energy and motors working by resonance, that is to say, having groups of tuned electromagnetic co-operating circuits render this possible but such do not form part of the present invention.

A motor adapted to operate with static charges, will for the sake of simplicity, be shown in the diagrams as two semi-circles **1** and **2** and the rotor of the motor by a ring **M** (**Fig.3**). **A** is a vertical aerial or aerial network. **S** is the safety choke or electromagnet with coil **O** as may be seen is connected with the aerial **A**. Adjacent to the electromagnet **S**, the aerial conductor is divided into three circuits, circuit **8** containing the safety spark gap, circuit **7** containing the working spark gap, and then a circuit containing the stator terminal **1**, the rotor and stator terminal **2** at which a connection is made to the earth wire. The two spark gaps are also connected metallically with the earth wire. The method of working in these diagrams is as follows:

The positive atmospheric electric charge collected tends to combine with the negative electricity (or earth electricity) connected via the earth wire. It travels along the aerial **A** through the electromagnet **S** without being checked as it flows in the same direction as the direct current. Further, its progress is arrested by two spark gaps placed in the way and the stator capacitors. These capacitors charge until their voltage exceeds that needed to jump the spark gap **7** when a spark occurs and an oscillatory charge is obtained via the closed oscillation circuit containing motor **M**. The motor here forms the capacity and the necessary inductance and resistance, which as is well known, are necessary for converting static electricity into electromagnetic wave energy.

The discharges are converted into mechanical energy in special motors and cannot reach the aerial network because of the electromagnet or choke. If, however, when a spark occurs at spark gap **7**, a greater quantity of atmospheric electricity tends to flow to earth, then a counter voltage is induced in the electromagnet, which is greater the more rapidly and strongly the flow of current direct to earth is. This opposing voltage causes the circuit to exhibit a sufficiently high resistance to prevent a short circuit between the atmospheric electricity and the earth.

The circuit containing spark gap **8**, having a different wave length which is not in resonance with the natural frequency of the motor, does not endanger the motor and serves as security against excess voltage, which, as practical experiments have shown, may still arise in certain cases.

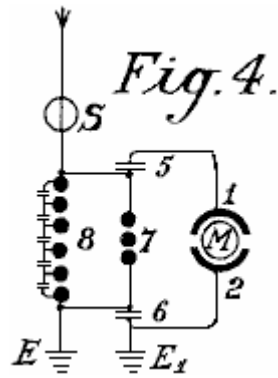

In **Fig. 4**, spark gap 7 is shunted across capacitors 5 and 6 from the motor M. This arrangement provides improved over-voltage protection for the motor and it gives a uniform excitation through the spark gap 7.

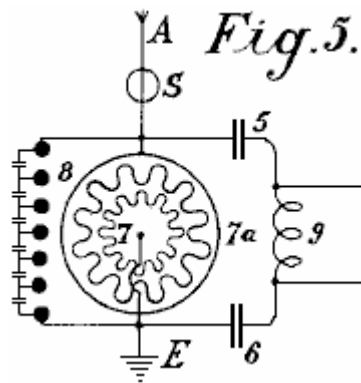

Fig. 5 shows an arrangement for producing large currents which can be used direct without motors, to provide heating and lighting. The main difference here is that the spark gap consists of a star-shaped disc 7 which can rotate on its own axis and is rotated by a motor opposite similarly fitted electrodes 7a. When separate points of starts face one another, discharges take place, thus forming an oscillation circuit with capacitors 5 and 6 and inductor 9. It is evident that a motor may also be connected directly to the ends of inductor 9.

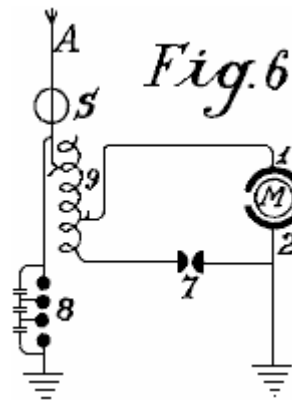
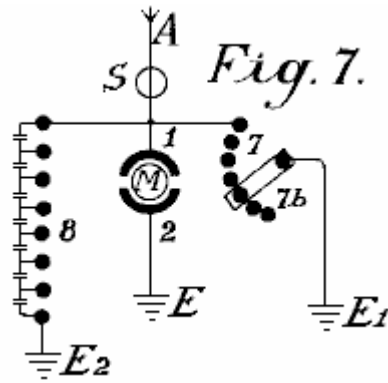

Fig. 6 shows how the oscillation circuit may have a motor connected via a variable inductor which opposes any excess voltages which might be applied to the motor. By cutting the separate coils 9 (coupled inductively to the aerial) in or out, the inductive action on the motor may be more or less increased, or variable aerial action may be exerted on the oscillation circuit.



In **Fig.7** the oscillation circuit is closed through the earth (E and E_1). The spark gap 7 may be increased or reduced by means of a contact arm $7b$.

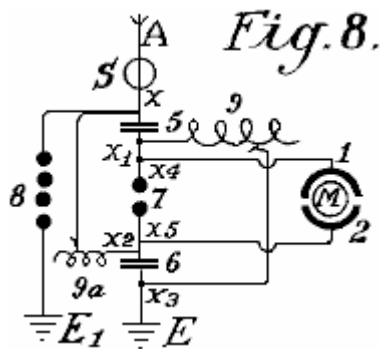

Fig.8 shows a unipolar connection of the motor with the aerial network. Here, two oscillation circuits are closed through the same motor. The first oscillation circuit passes from aerial A through electromagnet S , point x , inductance $9a$ to the earth capacitor 6 , across spark gap 7 to the aerial capacitor 5 and back to point x . The second oscillation circuit starts from the aerial 5 at the point x_1 through inductor 9 to the earth capacitor 6 at the point x_3 , through capacitor 6 , across spark gap 7 back to point x_1 . The motor itself, is inserted between the two points of spark gap 7 . This arrangement produces slightly dampened oscillation wave currents.

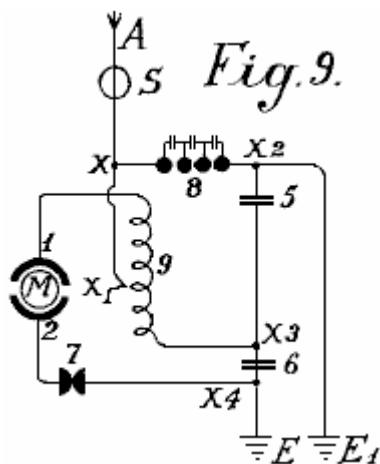

Fig.9 shows a loosely coupled system intended for small motors for measuring purposes. A is the aerial, S is the electromagnet or aerial inductor, 9 the inductor, 7 the spark gap, 5 and 6 capacitors, E the earth, M the motor, and 1 and 2 the stator connections of the motor which is directly connected to the oscillator circuit.

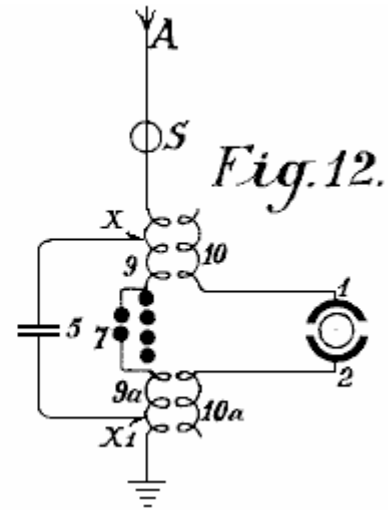
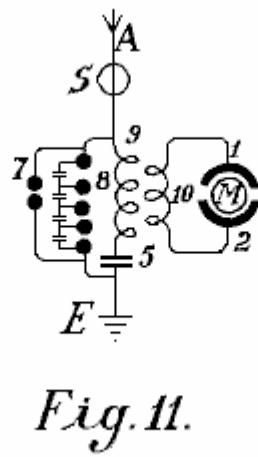
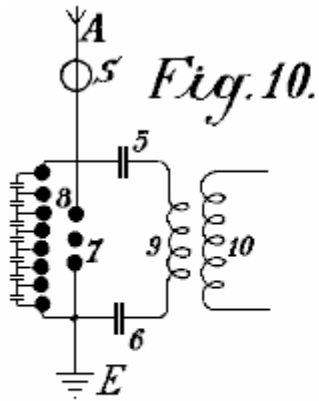
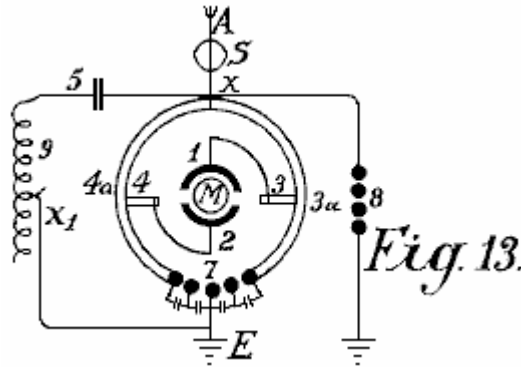

Fig.10 shows a motor circuit with purely inductive coupling. The motor is connected with the secondary wire **10** as may be seen in **Fig.11** in a somewhat modified circuit. The same applies to the circuit of **Fig.12**.

The circuit diagrams shown so far, allow motors of small to medium strength to be operated. For large aggregates, however, they are too inconvenient as the construction of two or more oscillation circuits for large amounts of energy is difficult; the governing is still more difficult and the danger in switching on or off is greater.



A means for overcoming such difficulties is shown in **Fig.13**. The oscillation circuit shown here, runs from point **x** over capacitor **5**, variable inductor **9**, spark gap **7** and the two segments **3a** and **3b** forming arms of a Wheatstone bridge, back to **x**. If the motor is connected by brushes **3** and **4** transversely to the two arms of the bridge as shown in the drawing, electromagnetic oscillations of equal sign are induced in the stator surfaces **1** and **2** and the motor does not revolve. If however, the brushes **3** and **4** are moved in common with the conducting wires **1** and **2** which connect the brushes with the stator poles, a certain alteration or displacement of the polarity is obtained and the motor commences to revolve.

The maximum action will result if one brush **3** comes on the central sparking contact **7** and the other brush **4** on the part **x**. In practice however, they are usually brought on to the central contact **7** but only held in the path of the bridge segments **4a** and **3a** in order to avoid connecting the spark gaps with the motor oscillation circuit.

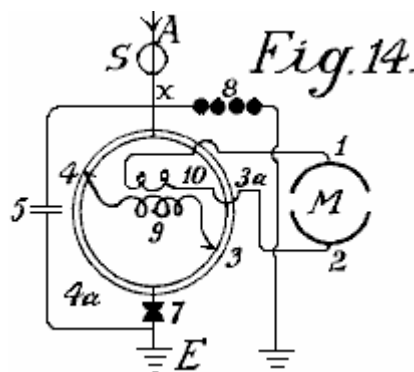

As this prevents the whole of the oscillation energy acting on the motor, it is better to adopt the modification shown in **Fig.14**. The only difference here is that the motor is not wired directly to the segments of the commutator, but instead it is wired to secondary coil **10** which receives induced current from primary coil **9**. This arrangement provides a good transforming action, a loose coupling and an oscillation circuit without a spark gap.

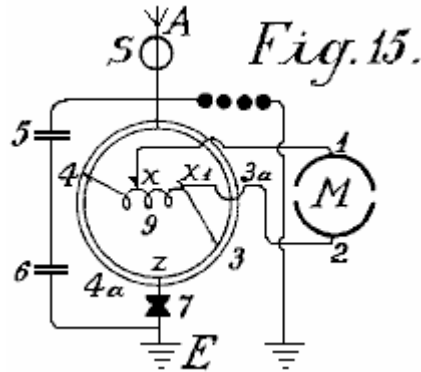

In **Fig.15**, the motor is wired directly to the primary coil at **x** and **x1** after the principle of the auto-transformer. In **Fig.16**, instead of an inductor, capacitor **6** replaces the inductance and is inserted between the segments **3a** and **4a**. This has the advantage that the segments **3a** and **4a** need not be made of solid metal, but may consist of spiral coils which allow a more exact regulation, and high inductance motors may be used.

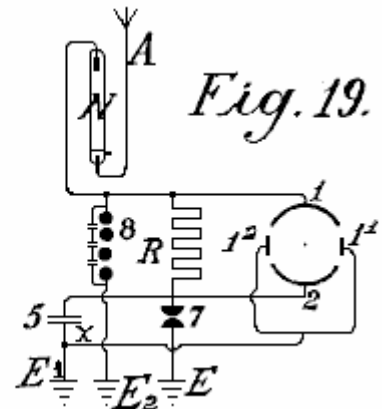
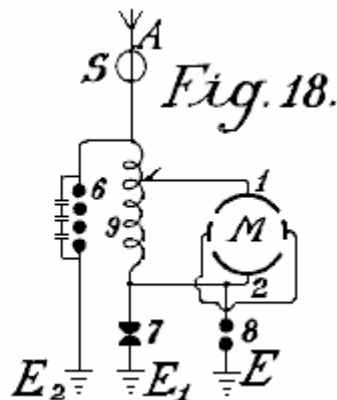
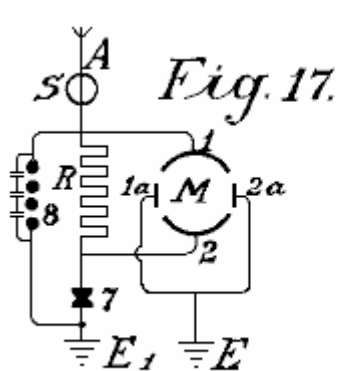

The circuits shown in **Fig.17**, **Fig.18** and **Fig.19** may be used with resonance and particularly with induction capacitor motors; between the large stator induction capacitor surfaces, small reversing pole capacitors are connected which are lead together to earth. Such reversing poles have the advantage that, with large quantities of electrical energy, the spark formation between the separate oscillation circuits ceases.

Fig.19 shows another method which prevents high frequency electromagnetic oscillations formed in the oscillation circuit, feeding back to the aerial. It is based on the well known principle that a mercury lamp, one electrode of which is formed of mercury, the other of solid metal such as steel, allows an electric charge to pass in only one direction: from the mercury to the steel and not vice versa. The mercury electrode of the vacuum tube **N** is therefore connected with the aerial conductor and the steel electrode with the oscillation circuit. Charges can then only pass from the aerial through the vacuum tube to the oscillation circuit and no flow occurs in the opposite direction. In practice, these vacuum tubes must be connected behind an electromagnet as the latter alone provides no protection against the danger of lightning.

As regards the use of spark gaps, all arrangements as used for wireless telegraphy may be used. Of course, the spark gaps in large machines must have a sufficiently large surface. In very large stations they are cooled in liquid carbonic acid or better still, in liquid nitrogen or hydrogen; in most cases the cooling may also take place by means of liquefied low homologues of the metal series or by means of hydrocarbons, the freezing point of which lies between -90°C and -40°C . The spark gap casing must also be insulated and be of sufficient strength to be able to resist any pressure which may arise. Any undesirable excess super-pressure which may be formed must

be let off automatically. I have employed with very good results, mercury electrodes which were frozen in liquid carbonic acid, the cooling being maintained during the operation from the outside, through the walls.

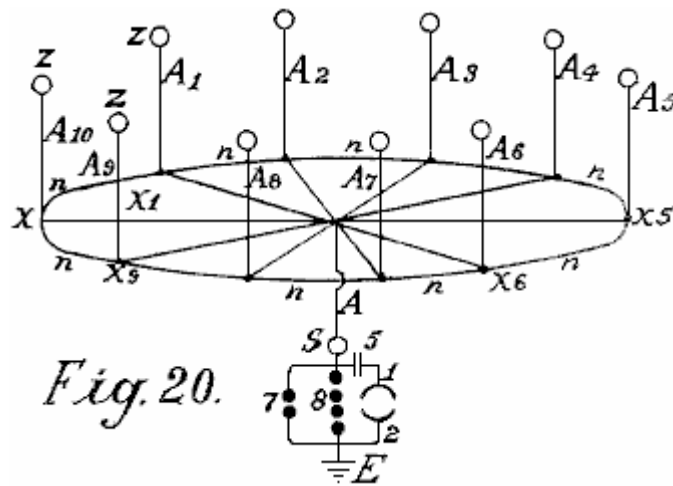

Fig.20 shows one of the most simple forms of construction of an aerial network in combination with collectors, transformers and the like. **E** is the earth wire, **8** the safety spark gap, **7** the working spark gap, **1** and **2** the stator surfaces of the motor, **5** a capacitor battery, **S** the protective magnet which is connected with the coil in the aerial conductor, **A¹ to A¹⁰** aerial antennae with collecting balloons, **N** horizontal collecting or connecting wires, from which, a number of connections run to the centre.

The actual collectors consist of metal sheaths, preferably made of an aluminium magnesium alloy, and are filled with hydrogen or helium, and are attached to copper-plated steel wires. The size of the balloon is selected so that the actual weight of the balloon and its conducting wire is supported by it. Aluminium spikes, made and gilded as described below, are arranged on top of the balloons in order to produce a conductor action. Small quantities of radium preparations, more particularly, polonium-ionium or mesothorium preparations, considerably increase the ionisation, and the performance of these collectors.

In addition to metal balloons, fabric balloons which are sprayed with a metallic coating according to Schoop's metal-spraying process may also be used. A metallic surface may also be produced by lacquering with metallic bronzes, preferably according to Schoop's spraying process, or lacquering with metallic bronze powders in two electrical series of widely different metals, because this produces a considerably increased collecting effect.

Instead of the ordinary round balloons, elongated cigar-shaped ones may be employed. In order also to utilise the frictional energy of the wind, patches or strips of non-conducting substances which produce electricity by friction, may be attached to the metallised balloon surfaces. The wind will impart a portion of its energy in the form of frictional electricity, to the balloon casing, thus substantially increasing the collection effect.

In practice however, very high towers of up to 300 metres may be employed as antennae. In these towers, copper tubes rise freely further above the top of the tower. A gas lamp secured against the wind is then lit at the point of the copper tube and a netting is secured to the copper tube over the flame of this lamp to form a collector. The gas is conveyed through the interior of the tube, up to the summit. The copper tube must be absolutely protected from moisture at the place where it enters the tower, and rain must be prevented from running down the walls of the tower, which might lead to a bad catastrophe. This is done by bell-shaped enlargements which expand downwards, being arranged in the tower in the form of high voltage insulators of Siamese pagodas.

Special attention must be devoted to the foundations of such towers. They must be well insulated from the ground, which may be achieved by first embedding a layer of concrete in a box form to a sufficient depth in the ground, and inserting in this, an asphalt lining and then glass bricks cast about 1 or 2 metres in thickness. Over this in turn, there is a ferro-concrete layer in which alone the metal foot of the tube is secured. This concrete block must be at least 2 metres from the ground and at the sides, be fully protected from moisture by a wooden covering. In the lower part of the tower, a wood or glass housing should be constructed to protect the capacitors and/or motors. In order to ensure that the ground lead connects to the water-table, a well insulated pit lined with vitreous bricks must be provided. Several such towers are erected at equal distances apart and connected with a horizontal conductor. The horizontal connecting wires may either run directly from tower to tower or be carried on bell-shaped insulators similar to those in use for high voltage electricity transmission lines. The width of the aerial tower network may be of any suitable size and the connection of the motors can take place at any convenient location.

Fig. 21.

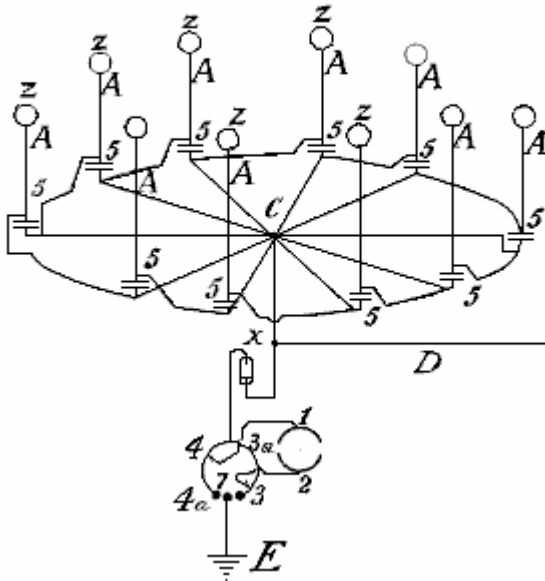
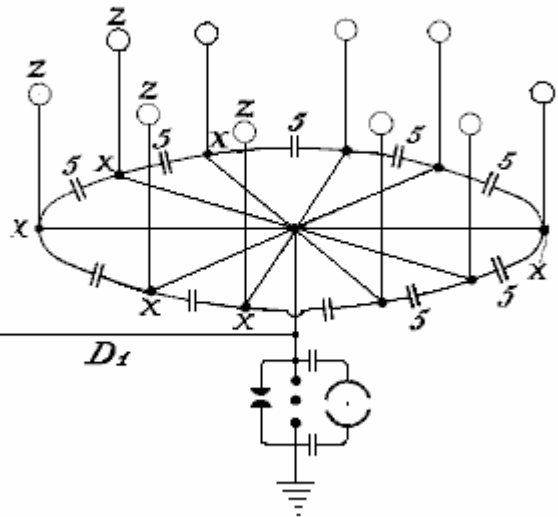
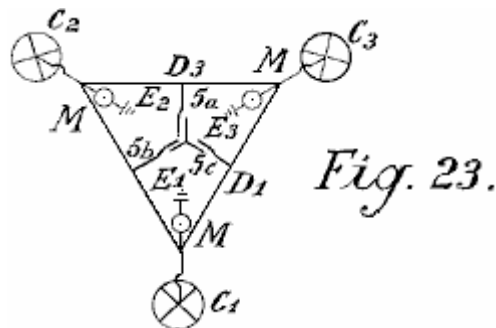

Fig. 22.



In order to collect large quantities of electricity with few aerials, it is as well to provide the aerial conductor with sets of capacitors as shown in the two methods of construction illustrated in **Fig.21** and **Fig.22**. In **Fig.21** the set of capacitors **5** is connected between the aerials **Z** via lead **A** and an annular conductor from which horizontal run to the connecting points **C** to which the earth wire is connected. **Fig.22** shows a similar arrangement.

Should two such series of antenna rings be shown by a voltmeter to have a large voltage difference (for example, one in the mountains and one on the plain) or even of a different polarity, these differences may be compensated for by connecting sufficiently large capacitor sets (**5**, **5a**, **5b**) by means of Maji star conductors **D** and **D¹**. **Fig.23**, shows a connection of three such rings of collectors are positioned in a triangle with a central set of capacitors.



The capacitor sets of such large installations must be embedded in liquefied gasses or in liquids freezing at very low temperatures. In such cases, a portion of the atmospheric energy must be employed for liquefying these gasses. It is also preferable to employ pressure. By this means, the capacitor surfaces may be reduced in area and still allow the storage of large quantities of energy to be stored, secure against breakdown. For the smaller installations, the immersing of the capacitors in well insulated oil or the like, is sufficient. Solid substances, on the other hand, cannot be employed as insulators.

The arrangement in the diagrams shown earlier has always shown both poles of the capacitors connected to the aerial conductors. An improved method of connection has been found to be very advantageous. In this method, only one pole of each capacitor is connected to the collecting network. Such a method of connection is very important, as by means of it, a constant current and an increase in the normal working voltage is obtained. If, for example, a collecting balloon aerial which is allowed to rise to a height of 300 metres, shows 40,000 volts above earth voltage, in practice it has been found that the working voltage (with a withdrawal of the power as described earlier by means of oscillating spark gaps and the like) is only about 400 volts. If however, the capacity of the capacitor surfaces be increased, which capacity in the above mentioned case was equal to that of the collecting surface of the balloon aerials, to double the amount, by connecting the capacitors with only one pole, the voltage rises under an equal withdrawal of current up to and beyond 500 volts. This can only be ascribed to the favourable action of the connecting method.

In addition to this substantial improvement it has also been found preferable to insert double inductances with electromagnets and to place the capacitors preferably between two such electromagnets. It has also been found that the useful action of such capacitors can be further increased if an induction coil is connected as an inductive resistance to the unconnected pole of the capacitor, or still better if the capacitor itself be made as an induction capacitor. Such a capacitor may be compared to a spring, which when compressed, carries in itself accumulated force, which it gives off again when released. In charging, a charge with reversed sign is formed at the other free capacitor pole, and if a short circuit occurs through the spark gap, the accumulated energy is again given back since now new quantities of energy are induced at the capacitor pole connected to the conductor network, which in fact, charges with opposite sign to that at the free capacitor pole. The new induced charges have of course, the same sign as the collector network. The whole voltage energy in the aerial is thereby increased. In the same time interval, larger quantities of energy are accumulated than is the case without such capacitor sets being inserted.

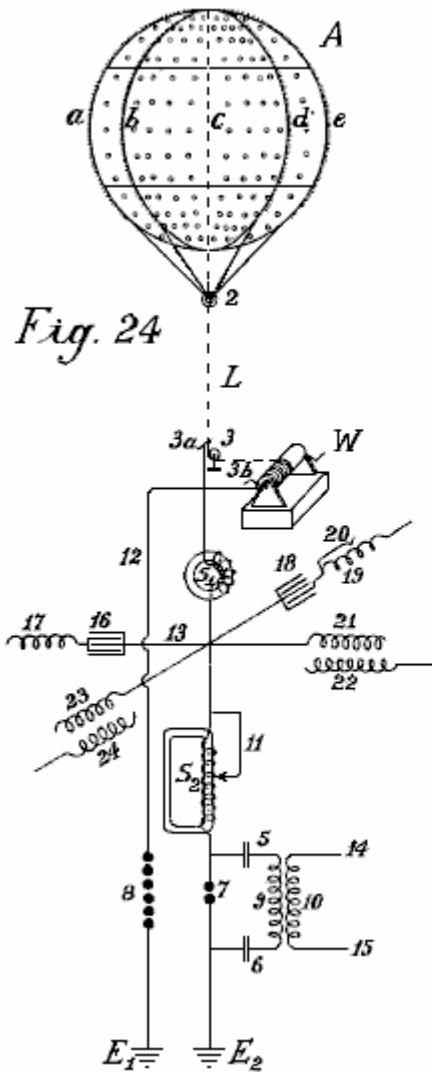

Fig. 24

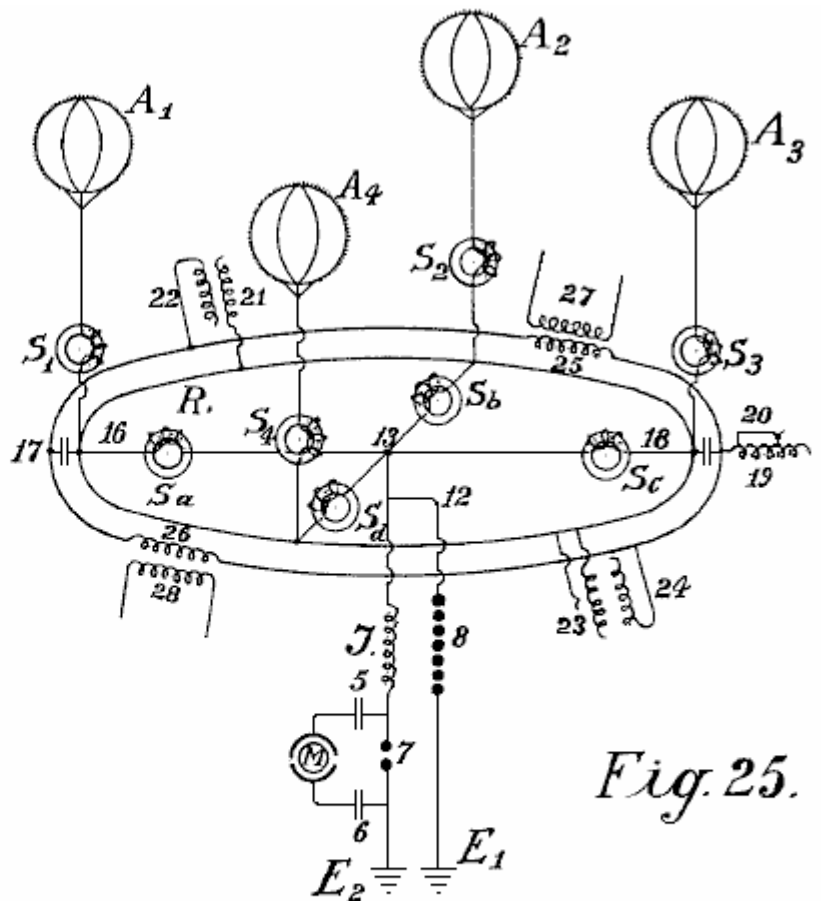

Fig. 25.

In **Fig. 24** and **Fig. 25**, two different connection diagrams are illustrated in more detail. **Fig. 24** shows a collecting balloon along with its earth connections. **Fig. 25** shows four collecting balloons and the parallel connection of their capacitor sets.

A is the collecting balloon made of an aluminium magnesium alloy (electron metal magnalium) of a specific gravity of 1.8 and a plate thickness of 0.1 mm to 0.2 mm. Inside, there are eight strong vertical ribs of T-shaped section of about 10 mm to 20 mm in height and about 3 mm in thickness, with the projecting part directed inwards (indicated by **a**, **b**, **c**, **d** and so forth). They are riveted together to form a firm skeleton and are stiffened in a horizontal direction by two cross ribs. The ribs are further connected to one another internally and transversely by means of thin steel wires, whereby the balloon obtains great strength and elasticity. Rolled plates of 0.1 mm to 0.2 mm in thickness made of magnalium alloy are then either soldered or riveted on to this skeleton so that a fully metallic casing with a smooth external surface is created. Well silvered or coppered aluminium plated steel wires run from each rib to the fastening ring **2**. Further, the coppered steel hawser **L**, preferably twisted out of separate thin wires (shown as dotted lines in **Fig. 24**) and which must be long enough to allow the balloon to rise to the

desired height, leads to a metal roller or pulley **3** and on to a winch **W**, which must be well insulated from the earth. By means of this winch, the balloon which is filled with hydrogen or helium, can be allowed to rise to a suitable height of 300 to 5,000 metres, and brought to the ground for recharging or repairs.

The actual current is taken directly through a friction contact from the metal roller **3** or from the wire or even from the winch, or simultaneously from all three by means of brushes (**3**, **3a** and **3b**). Beyond the brushes, the conductor is divided, the paths being:- firstly, over **12** to the safety spark gap **8**, on to the earth conductor **E¹**, and secondly over electromagnet **S¹**, point **13**, to a second loose electromagnet having an adjustable coil **S²**, then to the spark gap **7** and to the second earth conductor **E²**. The actual working circuit is formed through the spark gap **7**, capacitors **5** and **6**, and through the primary coil **9**; here the static electricity formed by oscillatory discharges is accumulated and converted into high frequency electromagnetic oscillations. Between the electromagnets **S¹** and **S²** at the crossing point **13**, four capacitor sets are introduced which are only indicated diagrammatically in the drawings by a single capacitor. Two of these sets of capacitors (**16** and **18**) are made as plate capacitors and prolonged by regulating induction coils or spirals **17** and **19** while the two others (**21** and **23**) are induction capacitors. As may be seen from the drawings, each of the four capacitor sets, **16**, **18**, **21** and **23** is connected by only one pole to either the aerial or to the collector conductor. The second poles **17**, **19**, **22** and **24** are open. In the case of plate capacitors having no inductive resistance, an induction coil is inserted. The object of such a spiral or coil is the displacement of phase of the induction current by $\frac{1}{4}$ periods, whilst the charging current of the capacitor poles which lie free in the air, works back to the collector aerial. The consequence of this is that in discharges in the collector aerial, the back-inductive action of the free poles allows a higher voltage to be maintained in the aerial collecting conductor than would otherwise be the case. It has also been found that such a back action has an extremely favourable effect on the wear of the contacts. Of course, the inductive effect may be regulated at will within the limits of the size of the induction coil, the length of the coil in action being adjustable by means of wire connection without induction (see **Fig.24** No. **20**).

S¹ and **S²** may also be provided with such regulating devices, in the case of **S²** illustrated by **11**. If excess voltage be formed, it is conducted to earth through wire **12** and spark gap **8**, or through any other suitable apparatus, since this voltage would be dangerous for the other components. The action of these capacitor sets has already been described.

The small circles on the collector balloon indicate places where small patches of extremely thin layers (0.01 to 0.05 mm thick) of zinc amalgam, gold amalgam or other photoelectric acting metals, are applied to the balloon casing of light metal. Such metallic patches may also be applied to the entire balloon as well as in greater thickness to the conducting network. The capacity of the collector is thereby considerably strengthened at the surface. The greatest possible effect in collecting may be obtained by polonium amalgams and the like. On the surface of the collector balloon, metal points or spikes are also fixed along the ribs. These spikes enhance the charge collection operation. Since it is well known that the sharper the spikes, the less the resistance of the spikes, it is therefore extremely important to use spikes which are as sharp as possible. Experiments have shown that the formation of the body of the spike or point also play a large part, for example, spikes made of bars or rollers with smooth surfaces, have point resistance many times greater than those with rough surfaces. Various kinds of spike bodies have been experimented with for the collector balloons and the best results were given with spikes which were made in the following way: Fine points made of steel, copper, nickel or copper and nickel alloys, were fastened together in bundles and then placed as anode with the points placed in a suitable electrolyte (preferably in hydrochloric acid or muriate of iron solutions) and so treated with weak current driven by 2 to 3 volts. After 2 to 3 hours, according to the thickness of the spikes, the points become extremely sharp and the bodies of the spikes have a rough surface. The bundle can then be removed and the acid washed off with water. The spikes are then placed as cathode in a bath containing a solution of gold, platinum, iridium, palladium or wolfram salts or their compounds, and coated at the cathode galvanically with a thin layer of precious metal, which must however be sufficiently firm to protect them from atmospheric oxidation.

Such spikes act at a 20 fold lower voltage almost as well as the best and finest points made by mechanical means. Still better results are obtained if polonium or radium salts are added to the galvanic bath when forming the protective layer or coating. Such pins have low resistance at their points and have excellent collector action even at one volt or lower.

In **Fig.24**, the three unconnected poles are not connected with one another in parallel. That is quite possible in practice without altering the principle of the free pole. It is also preferable to interconnect a series of collecting aerials in parallel to a common collector network. **Fig.25** shows such an arrangement. **A¹**, **A²**, **A³**, **A⁴** are four metal collector balloons with gold or platinum coated spikes which are electrolytically made in the presence of polonium emanations or radium salts, the spikes being connected over four electromagnets **S¹**, **S²**, **S³**, **S⁴**, through an annular conductor **R**. From this annular conductor, four wires run over four further electromagnets **S^a**, **S^b**, **S^c**, **S^d**, to the connecting point **13**. There, the conductor is divided, one branch passing over **12** and the safety spark gap **7** to the earth at **E¹**, the other over inductive resistance **J** and working spark gap **7** to the earth at

E². The working circuit, consisting of the capacitors **5** and **6** and a resonance motor or a capacitor motor **M**, such as already described, is connected in proximity around the sparking gap section **7**. Of course, instead of connecting the capacitor motor directly, the primary circuit for high frequency oscillatory current may also be inserted.

The capacitor sets are connected by one pole to the annular conductor **R** and can be either inductionless (**16** and **18**) or made as induction capacitors as shown by **21** and **23**. The free poles of the inductionless capacitors are indicated by **17** and **19**, and those of the induction capacitors by **22** and **24**. As may be seen from the drawings, all of these poles **17**, **22**, **19** and **24** may be interconnected in parallel through a second annular conductor without any fear that thereby the principle of the free pole connection will be lost. In addition to the advantages already mentioned, the parallel connection also allows an equalisation of the working voltage in the entire collector network. Suitably calculated and constructed induction coils **25** and **26** may also be inserted in the annular conductor of the free poles, by means of which, a circuit may be formed in the secondary coils **27** and **28** which allows current produced in this annular conductor by fluctuations of the charges, to be measured or otherwise utilised.

According to what has already been stated, separate collector balloons may be connected at equidistant stations distributed over the whole country, either connected directly with one another metallically or by means of intermediate suitably connected capacitor sets through high voltage conductors insulated from earth. The static electricity is converted through a spark gap, into high frequency dynamic electricity which may be utilised as a source of energy by means of a suitable connection method, various precautions being observed, and with special regulations. The wires leading from the collector balloons, have up to now been connected through an annular conductor without this endless connection, which can be regarded as an endless induction coil, being able to exert any action on the whole conductor system.

It has now been found that if the network conductor connecting the aerial collector balloons with one another, is not made as a simple annular conductor, but preferably short-circuited in the form of coils over a capacitor set or spark gap or through thermionic valves, then the total collecting network exhibits quite new properties. The collection of atmospheric electricity is thereby not only increased but an alternating field may easily be produced in the collector network. Further, the atmospheric electrical forces showing themselves in the higher regions, may also be obtained directly by induction. In **Fig.26** and **Fig.28**, a form of construction is shown, on the basis of which, the further foundations of the method will be explained in more detail.

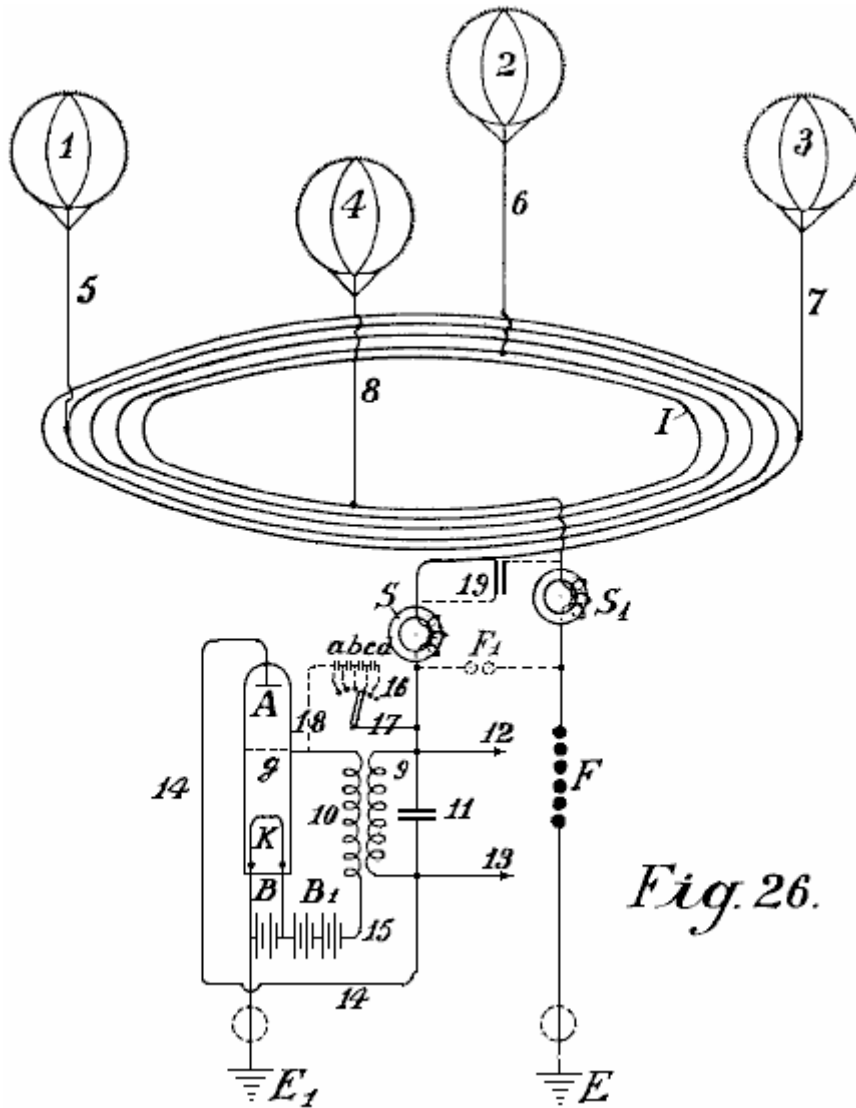

Fig. 26.

In **Fig.26**, 1,2,3 and 4 are metallic collector balloons, with 5, 6, 7 and 8 their metallic aerial conductors and I the actual collector network. This consists of five coils and is mounted on high voltage insulators in the air, on high voltage masts (or with a suitable construction of cable, embedded in the earth). One coil has a diameter of 1 to 100 km. or more. S and S¹ are two protective electromagnets, F is the second safety section against excess voltage, E its earth conductor and E¹ the earth conductor of the working section. When an absorption of static atmospheric electricity is effected through the four balloon collectors, in order to reach the earth connection E¹, the current must flow spirally through the collector network, over the electromagnet S, primary induction coil 9, conductor 14, anode A of the audion tube, incandescent cathode K, as the way over the electromagnet and safety spark gap F offers considerably greater resistance. Owing to the fact that the accumulated current flows in one direction, an electromagnetic alternating field is produced in the interior of the collector network coil, whereby all of the free electrons are directed more or less into the interior of the coil. An increased ionisation of the atmosphere is therefore produced. Consequently, the points mounted on the collector balloon, show a considerably reduced resistance and therefore increased static charges are produced between the points on the balloon and the surrounding atmosphere. This results in a considerably increased collector effect.

A second effect, which could not be achieved in any other way, is obtained by the alternating electromagnetic field running parallel to the earth's surface, which acts more or less with a diminishing or increasing effect on the earth's magnetic field, whereby in the case of fluctuations in the current, a return induction current of reversed sign is always produced in the collector coil by earth magnetism. Now if a constantly pulsating, continuous alternating field is produced as stated in the collector network I, an alternating current of the same frequency is also produced in the collecting network coil. As the same alternating field is further transmitted to the aerial balloon, the resistance of its points is thereby considerably reduced, while the collector action is considerably increased. A further advantage is that positive charges which collect on the metal surfaces during the conversion into dynamic current, produce a so-called voltage drop in the collector area. As an alternating field is present, when discharge of the collector surfaces takes place, the negative ions surrounding the collector surfaces produce, by the law of induction, an induction of reversed sign on the collector surface - that is, a positive charge. In addition to the advantages already stated, the construction of connecting conductors in coil form, when of

sufficiently large diameter, allows a utilisation of energy arising in higher regions, also in the most simple way. As is well known, electric discharges frequently take place at very great elevations which may be observed, such as 'St. Elmo's fires' or 'northern lights'. These energy quantities have not been able to have been utilised before now. By this invention, all of these kinds of energy, as they are of electromagnetic nature and since the axis of the collector coils is at right angles to the earth's surface, can be absorbed in the same way as a radio absorbs distant radio signals. With a large diameter of the spiral, it is possible to connect large surfaces and thereby take up large quantities of energy.

It is well known that in the summer months and in the tropics, large radio stations are very frequently unable to receive signals due to interruptions caused by atmospheric electricity, and this takes place with vertical coils of only 40 to 100 metres in diameter. If, on the contrary, horizontal coils of 1 to 100 kilometres in diameter are used, very strong currents may be obtained through discharges which are constantly taking place in the atmosphere. Particularly in the tropics, or still better in the polar regions where the northern lights are constantly present, large quantities of energy may probably be obtained in this way. A coil with several windings should perform the best. In a similar manner, any alteration of the earth's magnetic field should act inductively on such a coil.

It is not at all unlikely that earthquakes and sunspots will also produce an induction in collector coils of that size. In similar manner, this collector conductor will react to earth currents more particularly when they are near the surface of the earth or even embedded in the earth. By combining the previous kind of current collectors, so far as they are adapted for the improved system with the improved possibilities of obtaining current, the quantities of free natural energy which are to be obtained in the form of electricity are considerably increased.

In order to produce uniform undamped current oscillations in the improved collector coil, so-called audion high vacuum or thermionic valves are used instead of the previous described spark gaps (**Fig.26, 9-18**). The main aerial current flows through electromagnet **S** (which in the case of a high number of alternations is not connected here but in the earth conductor **E¹**) and may be conveyed over the primary coils in the induction winding through wire **14** to the anode **A** of the high vacuum grid valve. Parallel with the induction resistance **9**, a regulating capacity of suitable size, such as capacitor **11**, is inserted. In the lower part of the vacuum grid valve is the incandescent filament cathode **K** which is fed through a battery **B**. From the battery, two branches run, one to the earth conductor **E¹** and the other through battery **B¹** and secondary coil **10** to the grid anode **g** of the vacuum tube. By the method of connections shown in dotted lines, a desired voltage may also be produced at the grid electrode **g** through wire **17** which is branched off from the main current conductor through switches **16** and some small capacitors (**a, b, c, d**) connected in series, and conductor **18**, without the battery **B¹** being required. The action of the whole system is somewhat as follows:-

On the connecting conductor of the aerial collector network being short-circuited to earth, the capacitor pole **11** is charged, and slightly dampened oscillations are formed in the short-circuited oscillation circuit formed by capacitor **11** and self inductance **9**. Because of the coupling through coil **10**, voltage fluctuations of the same frequency take place in the grid circuit **15** and in turn, these fluctuations influence the strength of the electrode current passing through the high vacuum amplifying valve and thus produce current fluctuations of the same frequency in the anode circuit. A permanent supply of energy. Consequently, a permanent supply of energy is supplied to the oscillation circuits **9** and **10** takes place, until a balance is achieved where the oscillation energy consumed exactly matches the energy absorbed. This produces constant undamped oscillations in the oscillation circuits **9 - 11**.

For regular working of such oscillation producers, high vacuum strengthening tubes are necessary and it is also necessary that the grid and anode voltages shall have a phase difference of 180^0 so that if the grid is negatively charged, then the anode is positively charged and vice versa. This necessary difference of phase may be obtained by most varied connections, for example, by placing the oscillating circuit in the grid circuit or by separating the oscillation circuit and inductive coupling from the anodes and the grid circuit, and so forth.

A second important factor is that care must be taken that the grid and anode voltages have a certain relation to one another; the latter may be obtained by altering the coupling and a suitable selection of the self induction in the grid circuit, or as shown by the dotted lines **18, 17, 16** by means of a larger or smaller number of capacitors of suitable size connected in series; in this case, the battery **B¹** may be omitted. With a suitable selection of the grid potential, a glow discharge takes place between the grid **g** and the anode **A**, and accordingly at the grid there is a cathode drop and a dark space is formed. The size of this cathode drop is influenced by the ions which are emitted in the lower space in consequence of shock ionisation of the incandescent cathodes **K** and pass through the grid in the upper space. On the other hand, the number of the ions passing through the grid is dependent on the voltage between the grid and the cathode. Thus, if the grid voltage undergoes periodic fluctuations (as in the present case), the amount of the cathode drop at the grid fluctuates, and consequently, the internal resistance of the valve fluctuates correspondingly, so that when a back-coupling of the feed circuit with the grid circuit takes

place, the necessary means are in place for producing undamped oscillations and of taking current as required, from the collecting conductor.

With a suitably loose coupling, the frequency of the undamped oscillations produced is equal to the self-frequency of the oscillation circuits **9** and **10**. By selecting a suitable self-induction for coil **9** and capacitor **11**, it is possible to extend operation from frequencies which produce electromagnetic oscillations with a wavelength of only a few metres, down to the lowest practical alternating current frequency. For large installations, a suitable number of frequency producing tubes in the form of the well known high vacuum transmission tubes of 0.5 kW to 2 kW in size may be connected in parallel so that in this respect, no difficulty exists.

The use of such tubes for producing undamped oscillations, and the construction and method of inserting such transmission tubes in an accumulator or dynamo circuit is known, also, such oscillation producing tubes only work well at voltages of 1,000 volts up to 4,000 volts, so that on the contrary, their use at lower voltages is considerably more difficult. By the use of high voltage static electricity, this method of producing undamped oscillations as compared with that through spark gaps, must be regarded as an ideal solution, particularly for small installations with outputs from 1 kW to 100 kW.

By the application of safety spark gaps, with interpolation of electromagnets, not only is short-circuiting avoided but also the taking up of current is regulated. Oscillation producers inserted in the above way, form a constantly acting alternating electromagnetic field in the collector coil, whereby, as already stated, a considerable accumulating effect takes place. The withdrawal or 'working' wire is connected at **12** and **13**, but current may be taken by means of a secondary coil which is firmly or moveably mounted in any suitable way inside the large collector coil, i.e. in its alternating electromagnetic field, so long as the direction of its axis is parallel to that of the main current collecting coil.

In producing undamped oscillations of a high frequency (50 KHz and more) in the oscillation circuits **9** and **11**, electromagnets **S** and **S¹** must be inserted if the high frequency oscillations are not to penetrate the collector coil, between the oscillation producers and the collector coil. In all other cases they are connected shortly before the earthing (as in **Fig.27** and **Fig.28**).

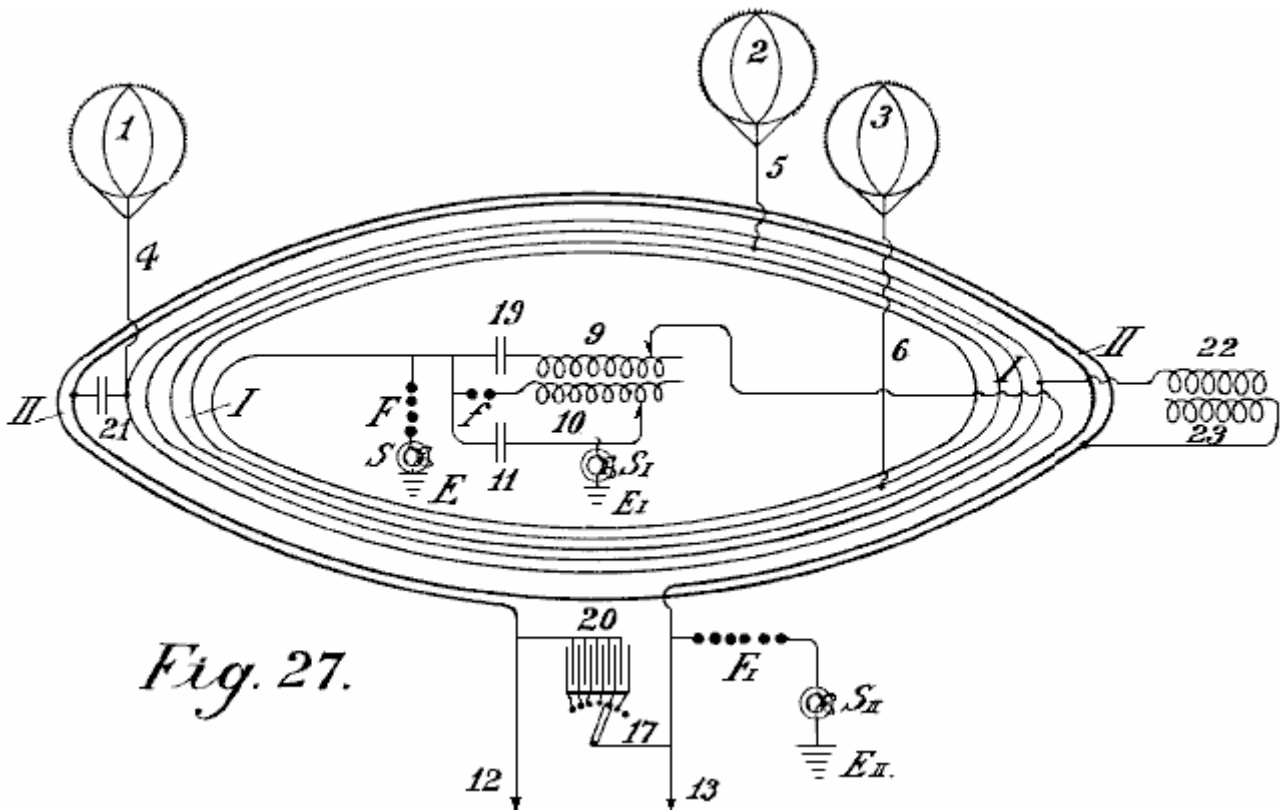

Fig. 27.

In **Fig.27** a second method of construction of the connecting conductor of the balloon aerials is illustrated in the form of a coil. The main difference is that in addition to the connecting conductor **I** another annular conductor **II** is inserted parallel to the former on the high voltage masts in the air (or embedded as a cable in the earth) but both in the form of a coil. The connecting wire of the balloon aerials is both a primary conductor and a current producing network while the coil is the consumption network and is not in unipolar connection with the current producing network.

In **Fig.27** the current producing network I is shown with three balloon collectors 1, 2, 3 and aerial conductors 4, 5, 6; it is short-circuited through capacitor 19 and inductor 9. The oscillation forming circuit consists of spark gap f, inductor 10 and capacitor 11. The earth wire E is connected to earth through electromagnet S^I. F_I is the safety spark gap which is also connected to earth through a second electromagnet S_{II} at E_{II}. On connecting up the capacitor circuit 11 it is charged over the spark gap f and an oscillatory discharge is formed. This discharging current acts through inductor 10 on the inductively coupled secondary 9, which causes a change in the producing network, by modifying the voltage on capacitor 19. This causes oscillations in the coil-shaped producer network. These oscillations induce a current in the secondary circuit II, which has a smaller number of windings and lower resistance, consequently, this produces a lower voltage and higher current in it.

In order to convert the current thus obtained, into current of an undamped character, and to tune its wavelengths, a sufficiently large regulatable capacitor 20 is inserted between the ends 12 and 13 of the secondary conductor II. Here also, current may be taken without an earth conductor, but it is advisable to insert a safety spark gap E¹ and to connect this with the earth via electromagnet S². The producer network may be connected with the working network II over an inductionless capacitor 21 or over an induction capacitor 22, 23. In this case, the secondary conductor is unipolarly connected with the energy conductor.

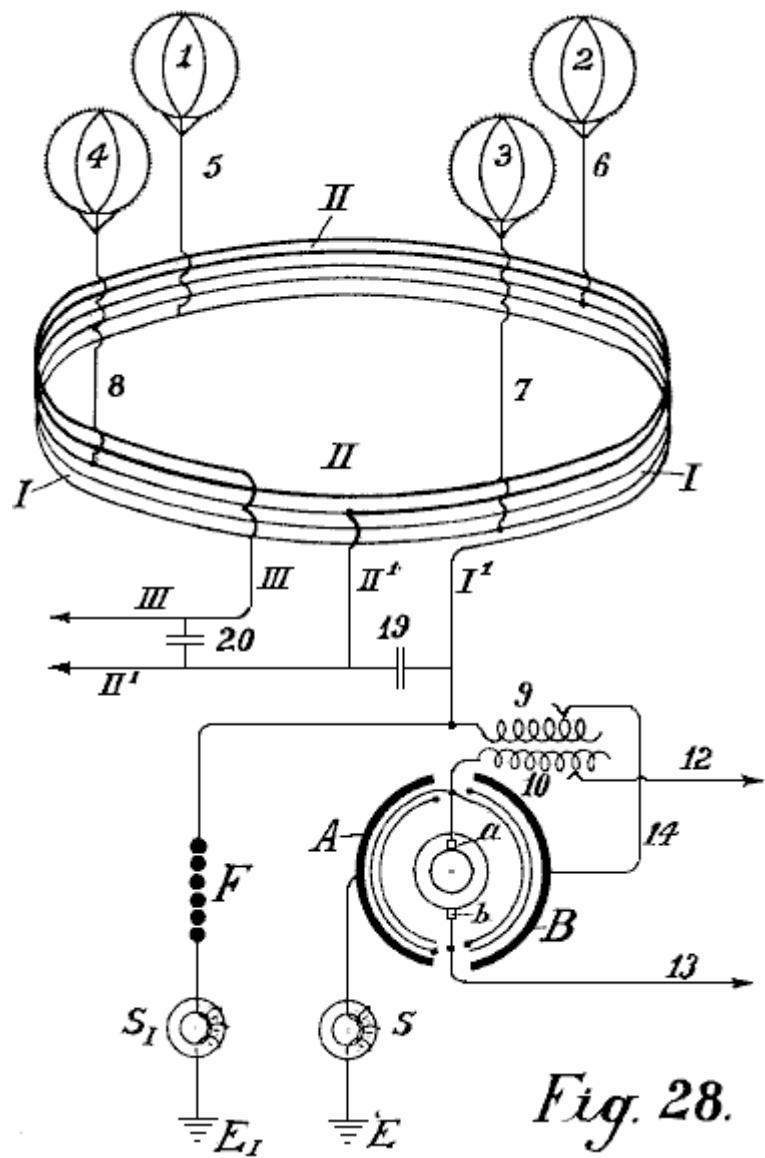

Fig. 28.

In **Fig.28**, the connecting conductor between the separate collecting balloons is carried out according to the autotransformer principle. The collecting coil connects four aerial balloons 1, 2, 3, 4, the windings of which are not made side-by-side but one above the other. In **Fig.28**, the collector coil I is shown with a thin line and the metallicly connected prolongation coils II with a thick line. Between the ends I¹ and II¹ of the energy network I, a regulating capacitor 19 is inserted. The wire I¹ is connected with the output wire and with the spark gap F.

As transformer of the atmospheric electricity, an arrangement is employed which consists of using rotary pairs of capacitors in which the stator surface **B** is connected with the main current, while the other **A** is connected to the earth pole. These pairs of short-circuited capacitors are caused to rotate and the converted current can be taken from them via two collector rings and brushes. This current is alternating current with a frequency dependent on the number of balloons and the rate of revolutions of the rotor. As the alternating current formed in the rotor can act through coils **10** on the inductor **9**, an increase or decrease of the feed current in **I** can be obtained according to the direction of the current by back-induction. Current oscillations of uniform rhythm are produced in the coil-shaped windings of the producer network.

As the ends of this conductor are short-circuited through the regulatable capacitor **19**, these rhythms produce short-circuited undamped oscillations in the energy conductor. The frequency of these oscillations can be altered at will by adjusting the capacitance of capacitor **19**. These currents may also be used as working current via the conductors **II**¹ and **III**. By inserting capacitor **20**, a connection between these conductors may also be made, whereby harmonic oscillations of desired wavelength are formed. By this means, quite new effects as regards current distribution are obtained. The withdrawal of current can even take place without direct wire connection if, at a suitable point in the interior of the producing network (quite immaterially whether this has a diameter of 1 or 100 km) a coil tuned to these wavelength and of the desired capacity, is firmly or moveably mounted in the aerial conductor in such a way that its axis is parallel with the axis of the collector coil. In this case, a current is induced in the producing network, the size of which is dependent on the total capacity and resistance and on the frequency selected. A future possibility is taking energy from the producer network by radio signals as in addition to atmospheric electricity, magnetic earth currents and energy from the upper atmosphere may be tapped.

Of course, vacuum tubes may be used to produce undamped oscillations anywhere spark gaps are shown in the circuits. The separate large-diameter coils of the producer network may be connected to one another through separate conductors all in parallel or all in series or in groups in series. By regulating the number of oscillations and the magnitude of the voltage, more or fewer large collector coils of this kind may be used. The coils may also be divided spirally over the entire section. The coils may be carried out in annular form or in triangular, quadrangular, hexagonal or octagonal form.

Of course, wires which form guides for the current waves, may be carried from a suitable place to the centre or also laterally. This is necessary when the currents have to be conducted over mountains and valleys and so forth. In all these cases, the current must be converted into a current of suitable frequency.

As already mentioned, separate collecting balloons may be directly metallicly interconnected at equidistant stations distributed over the entire country, or may be connected by interpolation of suitable capacitor sets by means of high voltage conductors. The static electricity is converted through a spark gap into dynamic energy of high frequency and could then in that form be used as an energy source after special regulation.

According to this invention, in order to increase the collecting effect of the balloon in the aerial collector conductor or in the earth wire, radiating collectors are used. These consist of either incandescent metal or oxide electrodes in the form of vacuum grid valves, or electric arcs (mercury or similar electrodes), Nernst lamps, or flames of various kinds maybe simply connected with the respective conductor.

It is well known that energy can be drawn off from a cathode consisting of an incandescent body opposite an anode charged with positive electricity (vacuum grid tube). Hitherto however, a cathode was always first directly placed opposite an anode, and secondly, the system always consisted of a closed circuit.

Now if we dispense with the ordinary ideas in forming light or flame arcs in which a cathode must always stand directly opposite an anode charged to a high voltage or another body freely floating in the air, or consider the incandescent cathode to be only a source of unipolar discharge, (which represents group and point discharges in electro-static machines similar to unipolar discharges), it may be ascertained that incandescent cathodes and less perfectly, all incandescent radiators, flames and the like, have relatively large current densities and allow large quantities of electric energy to radiate into open space in the form of electron streams as transmitters.

The object of this invention is as described below, if such incandescent oxide electrodes or other incandescent radiators or flames are not freely suspended in space but instead are connected metallicly with the earth so that they can be charged with negative terrestrial electricity, these radiators possess the property of absorbing the free positive electrical charges contained in the air space surrounding them (that is to say, of collecting them and conducting them to earth). They can therefore serve as collectors and have in comparison to the action of the spikes, a very large radius of action R ; the effective capacity of these collectors is much greater than the geometrical capacity (R_0) calculated in an electro-static sense.

As is well known, our earth is surrounded with an electro-static field and the difference of potential dV/dh of the earth field according to the latest investigations, is in summer about 60 to 100 volts, and in winter, 300 to 500 volts

per metre difference in height, a simple calculation gives the result that when such a radiation collector or flame collector is arranged, for example, on the ground, and a second one is mounted vertically over it at a distance of 2,000 metres and both are connected by a conducting cable, there is a voltage difference in summer of about 2,000,000 volts and in winter 6,000,000 volts or more.

According to Stefan Boltzmann's law of radiation, the quantity of energy which an incandescent surface (temperature T) of 1 sq. cm. radiates in a unit of time into the open air (temperature T_0) is expressed by the following formula:

$$S = R (T^4 - T_0^4) \text{ watts per square centimetre}$$

and the universal radiation constant R, according to the latest researches of Ferry, is equal to 6.30×10^{-12} watts per square centimetre.

Now, if an incandescent surface of 1 sq. cm., as compared to the surrounding space, shows a periodic fall of potential dV, it radiates (independent of the direction of the current) in accordance with the above formula, for example at a temperature of 3715° C. an energy of 1.6 kW per square centimetre. As for the radiation, the same value can be calculated for the collection of energy, but reversed. Now, as carbon electrodes at the temperature of the electric arc, support a current density up to 60 to 65 amps per sq. cm., no difficulties will result in this direction in employing radiating collectors as accumulators.

If the earth be regarded as a cosmically insulated capacitor in the sense of geometrical electro-statics x, according to Chwolson, there results from the geometric capacity of the earth:

$$\text{For negative charging } 1.3 \times 10^6 \text{ Coulomb} \quad \text{For negative potential } V = 10 \times 10^8 \text{ volts.}$$

It follows from this that EJT is approximately equal to 24.7×10^{24} watts/sec. Now if it is desired to make a theoretical short circuit through an earthed flame collector, this would represent an electrical total work of about $79,500 \times 10^{10}$ kilowatt years. As the earth must be regarded as a rotating mechanism which is thermodynamically, electromagnetically and kinematically coupled with the sun and star system by cosmic radiation and gravitation, a reduction in the electric energy of the earth field is not to be feared. The energies which the incandescent collectors could withdraw from the earth field can only cause a lowering of the earth temperature. This is however, not the case as the earth does not represent a cosmically entirely insulated system. On the contrary, there is conveyed from the sun to the earth an energy of $18,500 \times 10^{10}$ kilowatts. Accordingly, any lowering of the earth temperature without a simultaneous lowering of the sun's temperature would contradict Stefan Boltzmann's law of radiation.

From this it must be concluded that if the earth temperature sinks, the total radiation absorbed by the earth increases, and further, the rate of cooling of the earth is directly dependent on that of the sun and the other radiators cosmically coupled with the sun.

The incandescent radiation collectors may, according to this invention, be used for collecting atmospheric electricity if they (1) are charged with the negative earth electricity (that is to say, when they are directly connected to the earth by means of a metallic conductor) and (2) if large capacities (metal surfaces) charged with electricity are mounted opposite them as positive poles in the air. This is regarded as the main feature of the present invention as without these inventive ideas it would not be possible to collect with an incandescent collector, sufficiently large quantities of the electrical charges contained in the atmosphere as technology requires; the radius of action of the flame collectors would also be too small, especially if it be considered that the very small surface density does not allow of large quantities of charge being absorbed from the atmosphere.

It has already been proposed to employ flame collectors for collecting atmospheric electricity and it is known that their collecting effect is substantially greater opposite the points. It is however, not known that the quantities of current which hitherto be obtained are too small for technical purposes. According to my experiments, the reason for this is to be found in the inadequate capacities of the collector conductor poles. If such flame or radiating collectors have no or only small positive surfaces, their radius of action for large technical purposes is too small. If the incandescent collectors be constantly kept in movement in the air, they may collect more according to the speed of the movement, but this is again not capable of being carried out in practice.

By this invention, the collector effect is considerably increased by a body charged with a positive potential and of the best possible capacity, being also held floating (without direct earth connection) opposite such an incandescent collector which is held floating in the air at a desired height. If, for example, a collecting balloon of sheet metal or metallised fabric, be caused to mount to 300 to 3,000 metres in the air, and as a positive pole it is brought opposite such a radiating collector connected by a conductor to earth, quite different results are obtained.

The metallic balloon shell which has a large surface area is charged to a high potential by atmospheric electricity. This potential is greater the higher the collecting balloon is above the incandescent collector. The positive electricity acts concentratedly on the anode floating in the air as it is attracted through the radiation shock ionisation, proceeding from the incandescent cathode. The consequence of this is that the radius of action of the incandescent cathode collector is considerably increased and so is the collecting effect of the balloon surface. Further, the large capacity of the anode floating in the air, plays therefore an important part because it allows the collection of large charges resulting in a more uniform current even when there is substantial current withdrawal - this cannot be the case with small surfaces.

In the present case, the metallic collecting balloon is a positive anode floating in the air and the end of the earth conductor of this balloon serves as positive pole surface opposite the surface of the radiating incandescent cathode, which in turn is charged with negative earth electricity as it is connected to the earth by a conductor. The process may be carried out by two such contacts (negative incandescent cathode and anode end of a capacity floating in the air) a capacitor and an inductive resistance being switched on in parallel, whereby simultaneously undamped oscillations may be formed.

In very large installations it is advisable to connect two such radiating collectors in series. Thus an arc light incandescent cathode may be placed below on the open ground and an incandescent cathode which is heated by special electro-magnetic currents, be located high in the air. Of course for this, the special vacuum Liebig tubes with or without grids may also be used. An ordinary arc lamp with oxide electrodes may be introduced on the ground and the positive pole is not directly connected with the collecting balloon, but through the upper incandescent cathode or over a capacitor. The method of connecting the incandescent cathode floating in the air may be seen in **Figs.29-33**.

B is the air balloon, **K** a Cardan ring (connection with the hawser) **C** the balloon, **L** a good conducting cable, **P** a positive pole, **N** negative incandescent cathode and **E** the earth conductor.

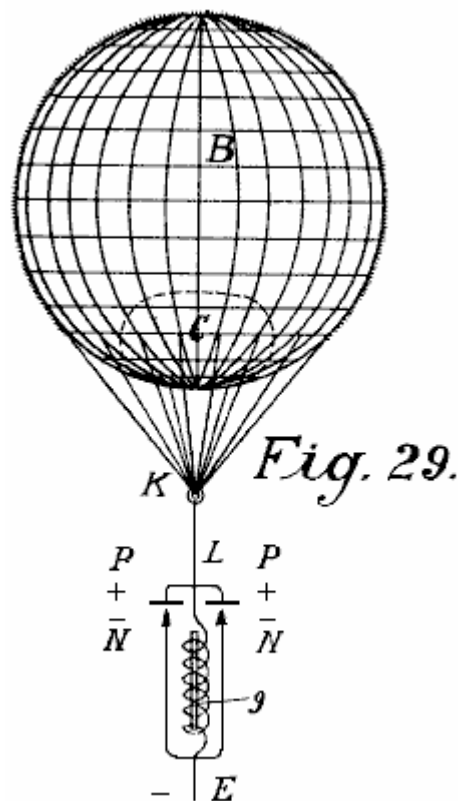

Fig.29 represents the simplest form of construction. If electric oscillations are produced below on the ground by means of a carbon arc lamp or in any other suitable way, a considerably greater electric resistance is opposed to that in the direct way by inserting an electrical inductive resistance **9**. Consequently, between **P** and **N**, a voltage is formed, and as, over **N** and **P** only an inductionless ohmic resistance is present, a spark will spring over so long as the separate induction coefficients and the like are correctly calculated. The consequence of this is that the oxide electrode (carbon or the like) is rendered incandescent and then shows as incandescent cathode, an increased collecting effect. The positive poles must be substantially larger than the negative in order that they may not also become incandescent. As they are further connected with the large balloon area which has a large capacity and is charged at high voltage, an incandescent body which is held floating in the air and a positive pole which can collect large capacities is thereby obtained in the simplest way. The incandescent cathode is first

caused to become incandescent by means of separate energy produced on the earth, and then maintained by the energy collected from the atmosphere.

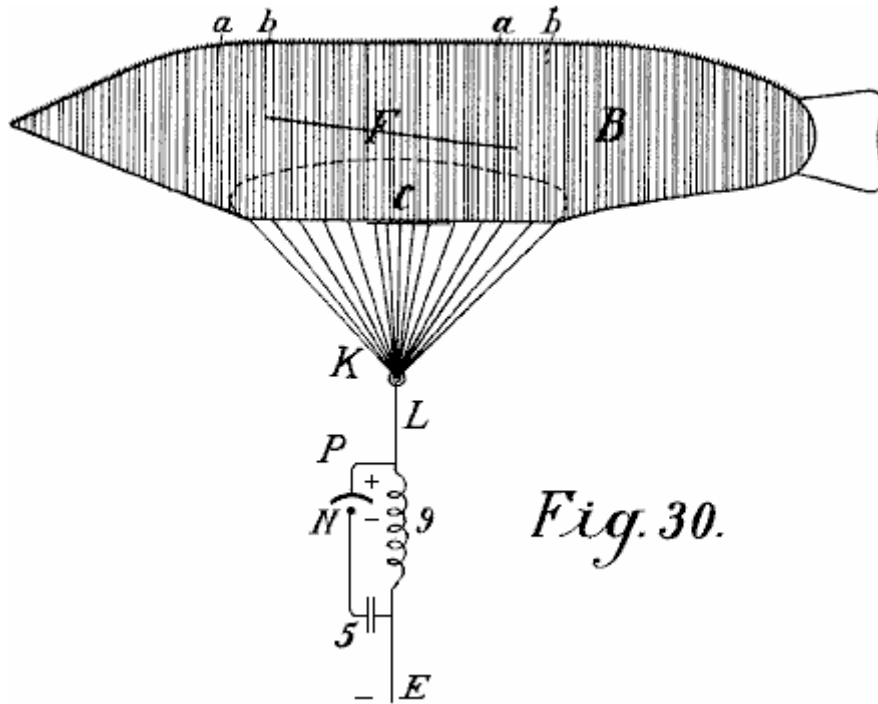
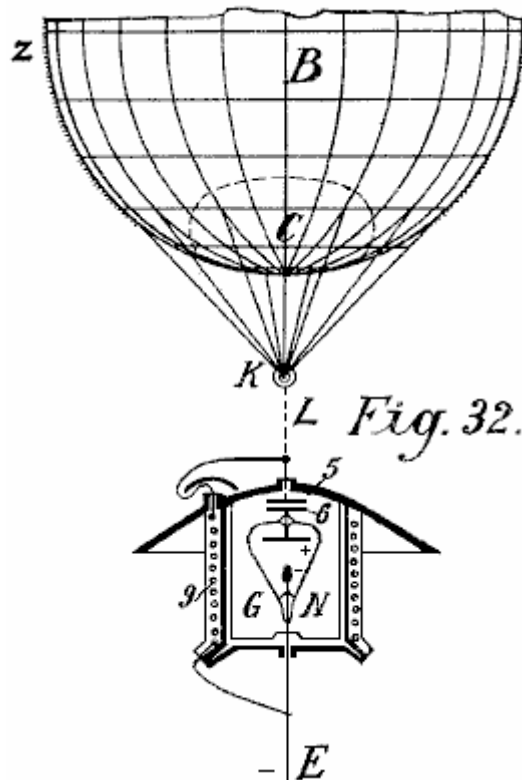

Fig.30 only shows the difference that instead of a round balloon, a cigar-shaped one may be used, also, a capacitor **5** is inserted between the incandescent cathode and the earth conductor so that a short-circuited oscillation circuit over **P N 5** and **9** is obtained. This has the advantage that quite small quantities of electricity cause the cathode to become incandescent and much larger cathode bodies may be made incandescent.



In this form of construction, both the incandescent cathode and the positive electrode may be enclosed in a vacuum chamber as shown in **Fig.32**. A cable **L** is carried well insulated through the cover of a vessel and ends in a capacitor disc **5**. The cover is arched in order to keep the rain off. The vessel is entirely or partially made of magnetic metal and well insulated inside and outside. Opposite disc **5** another disc **6** and on this again a metallic positive pole of the vacuum tube **g** with the incandescent cathode (oxide electrode) **N** is arranged. The negative electrode is on the one hand connected to the earth conductor **E**, and on the other hand with the inductive resistance **9** which is also connected with the cable **L** with the positive pole and wound around the vessel in coils.

The action is exactly the same as that in **Fig.29** only instead of an open incandescent cathode, one enclosed in vacuo is used. As in such collectors, only small bodies be brought to incandescence, in large installations a plurality of such vacuum tubes must be inserted in proximity to one another. According to the previous constructions **Fig.31** and **Fig.33** are quite self evident without further explanations.

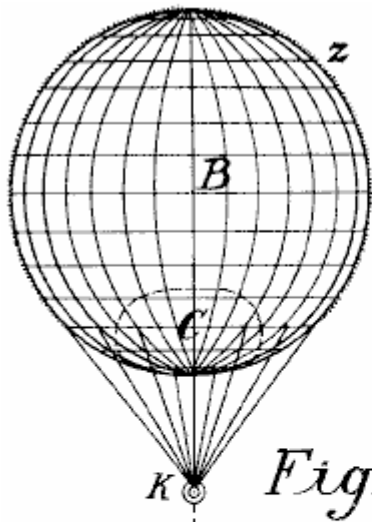

Fig.31.

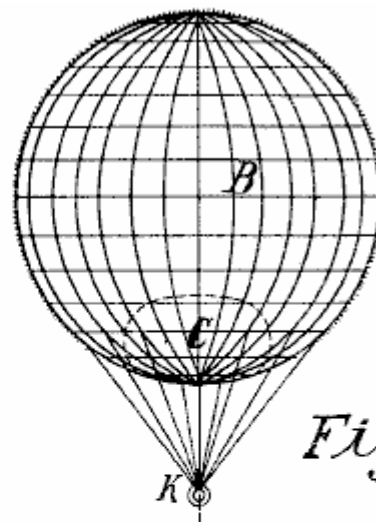
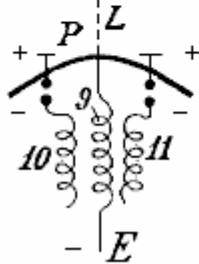

Fig.33.

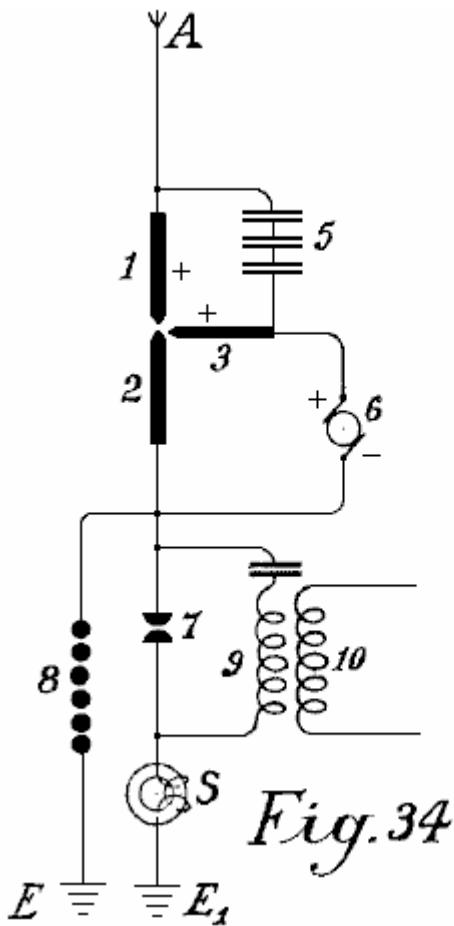
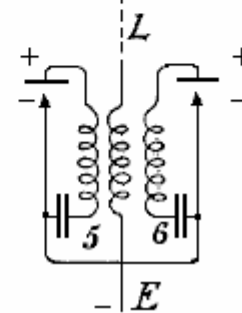

Fig.34

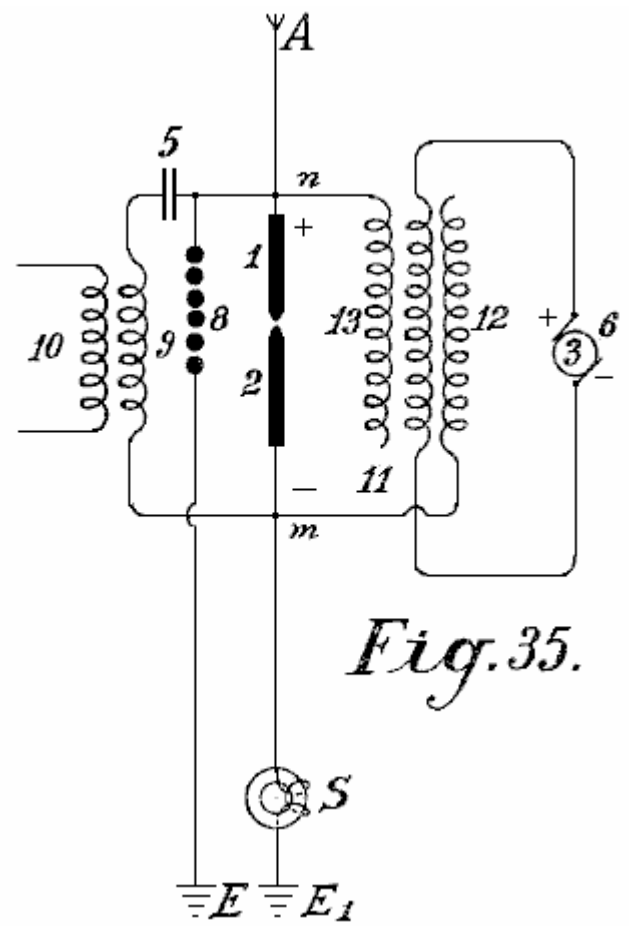
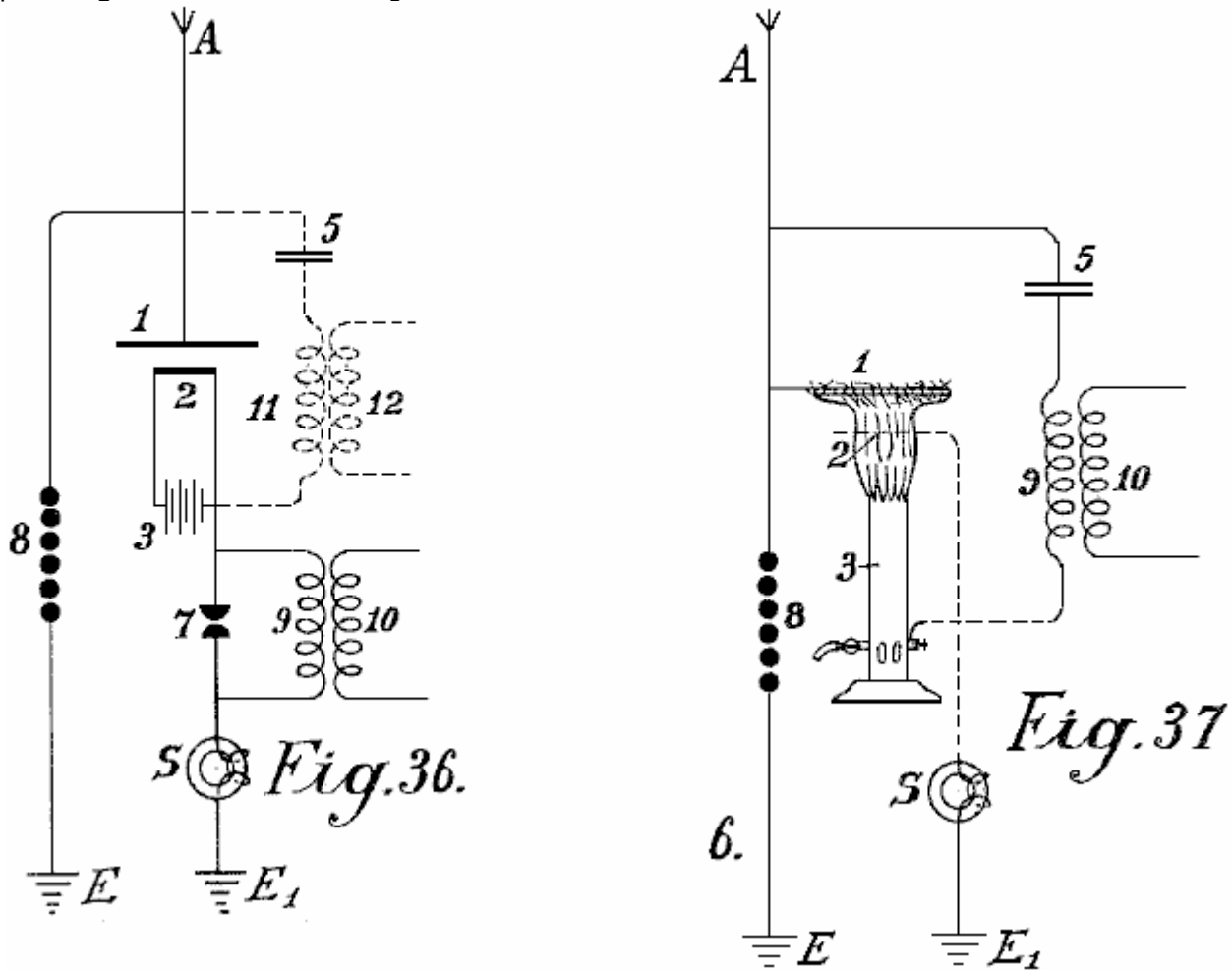

Fig.35.

Figs.34-37 represent further diagrams of connections over radiating and flame collectors, and in fact, how they are to be arranged on the ground. **Fig.34** shows an arc light collector with oxide electrodes for direct current and its connection. **Fig.35** shows a similar one for alternating current. **Fig.36** an incandescent collector with a Nernst lamp and **Fig.37** a similar one with a gas flame.



The positive pole 1 of the radiating collectors is always directly connected to the aerial collecting conductor A. In **Fig.34**, this is further connected over the capacitor set 5 with a second positive electrode 3. The direct current dynamo **b** produces current which flows over between the electrodes 3 and 2 as an arc light. On the formation of an arc, the negative incandescent electrode 2 absorbs electricity from the positive poles standing opposite it and highly charged with atmospheric electricity which it conveys to the working circuit. The spark gap 7, inductive resistance 9 and induction coil 10 are like the ones previously described. The protective electromagnet **S** protects the installation from earth circuiting and the safety spark gap 8 from excess voltage or overcharging.

In **Fig.35**, the connection is so far altered that the alternating current dynamo feeds the excitation coil 11 of the induction capacitor. 12 is its negative and 13 its positive pole. If the coil 3 on the magnet core of the dynamo is correctly calculated and the frequency of the alternating current sufficiently high, then an arc light can be formed between poles 1 and 2. As the cathode 2 is connected to the negatively charged earth, and therefore always acts as a negative pole, a form of rectification of the alternating current produced by the dynamo 3 is obtained, since the second half of the period is always suppressed. The working circuit may be carried out in the same way as in **Fig.34**; the working spark gap 7 may however be dispensed with, and instead of it, between the points **n** and **m**, a capacitor 5 and an induction resistance 9 may be inserted, from which, a current is taken inductively.

Fig.36 represents a form of construction similar to that shown in **Fig.34** except that here instead of an arc lamp, a Nernst incandescent body is used. The Nernst lamp is fed through the battery 3. The working section is connected with the negative pole, the safety spark gap with the positive poles. The working spark gap 7 may also be dispensed with and the current for it taken at 12 over the oscillation circuit 5, 11 (shown in dotted lines).

Flame collectors (**Fig.37**) may also be employed according to this invention. The wire network 1 is connected with the aerial collector conductor A and the burner with the earth. At the upper end of the burner, long points are provided which project into the flame. The positive electrode is connected with the negative over a capacitor 5 and the induction coil 9 with the earth.

The novelty in this invention is:

- (1) The use of incandescent cathodes opposite positive poles which are connected to large metallic capacities as automatic collecting surfaces.
- (2) The connection of the incandescent cathodes to the earth whereby, in addition to the electricity conveyed to them from the battery of machine which causes the incandescing, also the negative charge of the earth potential is conveyed, and
- (3) The connection of the positive and negative poles of the radiating collectors over a capacitor circuit alone or with the introduction of a suitable inductive resistance, whereby simultaneously an oscillatory oscillation circuit may be obtained. The collecting effect is by these methods quite considerably increased.

APPARATUS FOR PRODUCING ELECTRICITY

ABSTRACT

A rectifier for use with apparatus for producing electricity from the earth consists of mercury- vapour lamps constructed and arranged as shown in **Fig.4**. Each lamp comprises two wires **6<1>**, **7<1>** wound around a steel tube **15** surrounding a mercury tube **11** preferably of copper. The coil **6<1>** is connected between the electrode **14** and the terminal **18**, and the coil **7<1>** between the terminals **19**, **5**. The coils **6<1>**, **7<1>** are preferably composed of soft iron.

DESCRIPTION

This invention relates to improvements in apparatus for the production of electrical currents, and the primary object in view is the production of a commercially serviceable electrical current without the employment of mechanical or chemical action. To this end the invention comprises means for producing what I believe to be dynamic electricity from the earth and its ambient elements.

I am, of course aware that it has been proposed to obtain static charges from upper strata of the atmosphere, but such charges are recognised as of widely variant potential and have thus far proved of no practical commercial value, and the present invention is distinguished from all such apparatus as has heretofore been employed for attracting static charges by the fact that this improved apparatus is not designed or employed to produce or generate irregular, fluctuating or other electrical charges which lack constancy, but on the other hand I have by actual test been able to produce from a very small apparatus at comparatively low elevation, say about 50 or 60 feet above the earth's surface, a substantially constant current at a commercially usable voltage and amperage.

This current I ascertained by repeated tests is capable of being readily increased by additions of the unit elements in the apparatus described below, and I am convinced from the constancy of the current obtained and its comparatively low potential that the current is dynamic and not static, although, of course, it is not impossible that certain static discharges occur and, in fact, I have found occasion to provide against the damage which might result from such discharge by the provision of lightning arresters and cut-out apparatus which assist in rendering the obtained current stable by eliminating sudden fluctuations which sometimes occur during conditions of high humidity from what I consider static discharges.

The nature of my invention is obviously such that I have been unable to establish authoritatively all of the principles involved, and some of the theories herein expressed may possibly prove erroneous, but I do know and am able to demonstrate that the apparatus which I have discovered does produce, generate, or otherwise acquire a difference of potential representing a current amperage as stated above.

The invention comprises the means for producing electrical currents of serviceable potential substantially without the employment of mechanical or chemical action, and in this connection I have been able to observe no chemical action whatever on the parts utilised although deterioration may possibly occur in some of the parts, but so far as I am able to determine such deterioration does not add to the current supply but is merely incidental to the effect of climatic action.

The invention more specifically comprises the employment of a magnet or magnets and a co-operating element, such as zinc positioned adjacent to the magnet or magnets and connected in such manner and arranged relative to the earth so as to produce current, my observation being that current is produced only when such magnets have their poles facing substantially to the north and south and the zincs are disposed substantially along the magnets.

The invention also comprehends other details of construction, combinations and arrangements of parts as will be fully set forth.

DESCRIPTION OF THE DRAWINGS

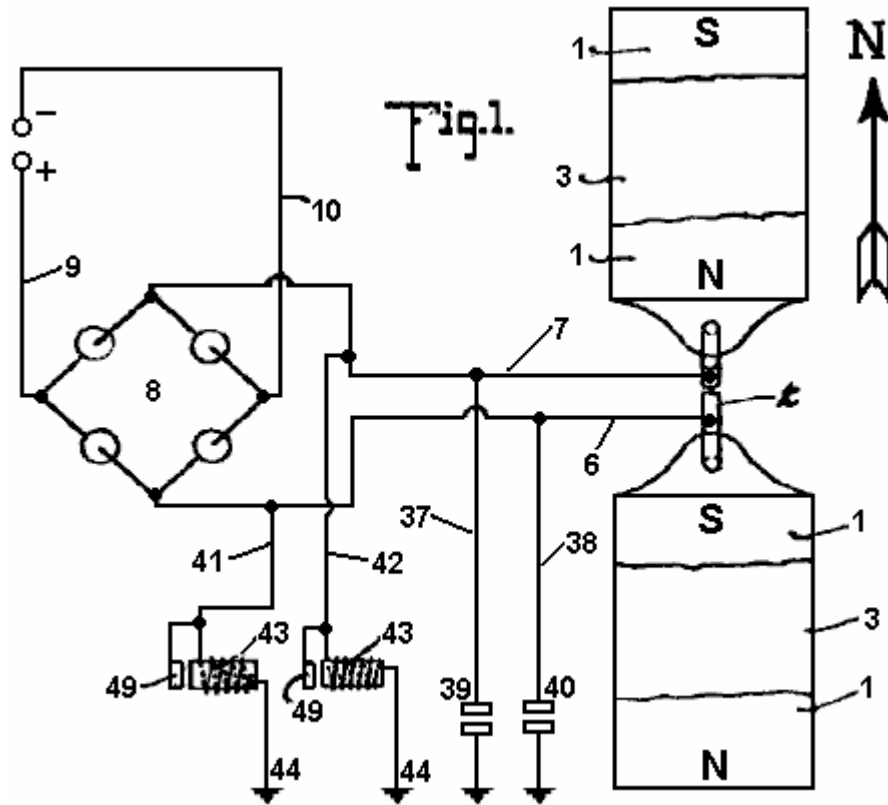

Fig.1 is a plan view of an apparatus embodying the features of the present invention, the arrow accompanying the figure indicating substantially the geographical north, parts of this figure are diagrammatic.

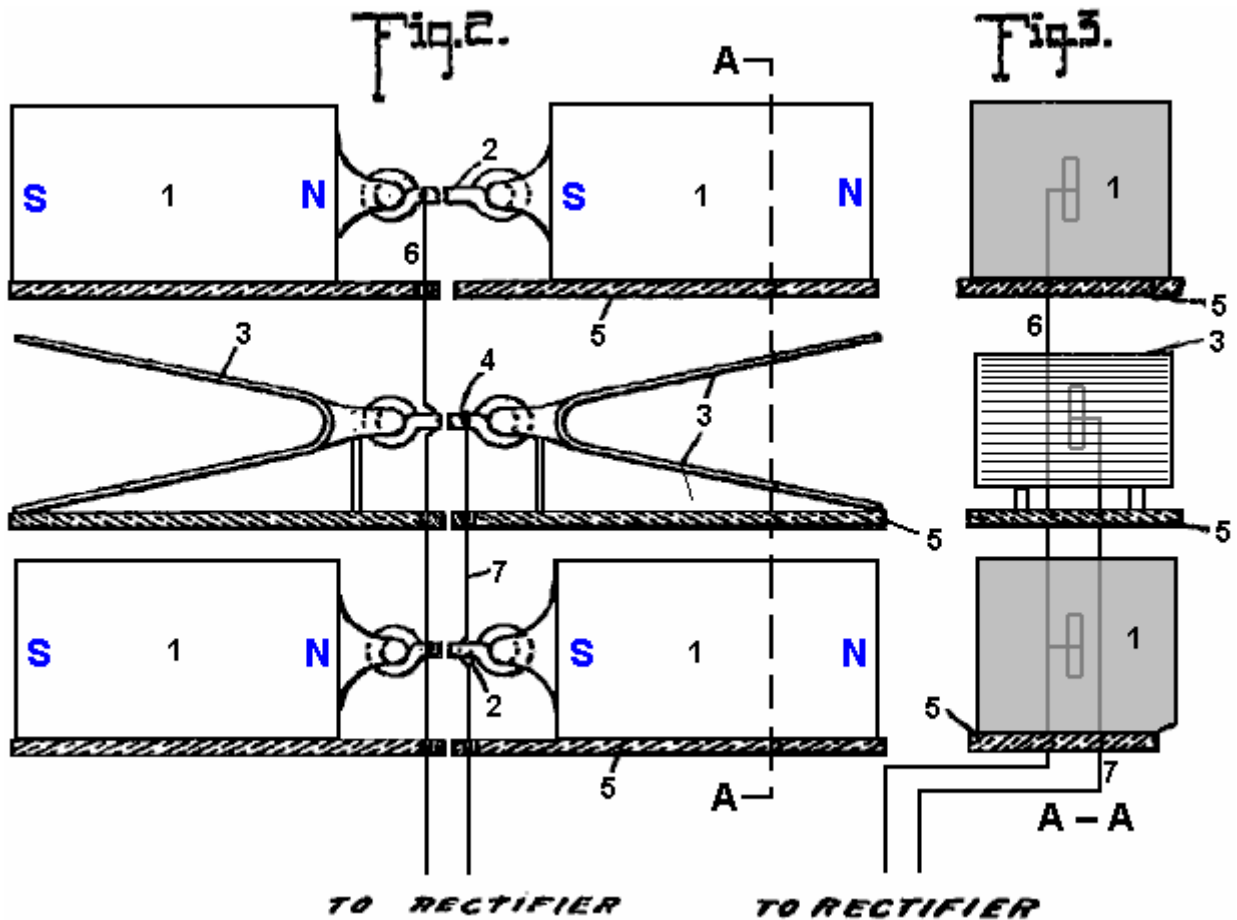

Fig.2 is a view in side elevation of the parts seen in plan in **Fig.1**
Fig.3 is a vertical section taken on the plane indicated by the line A-A of **Fig.2**.

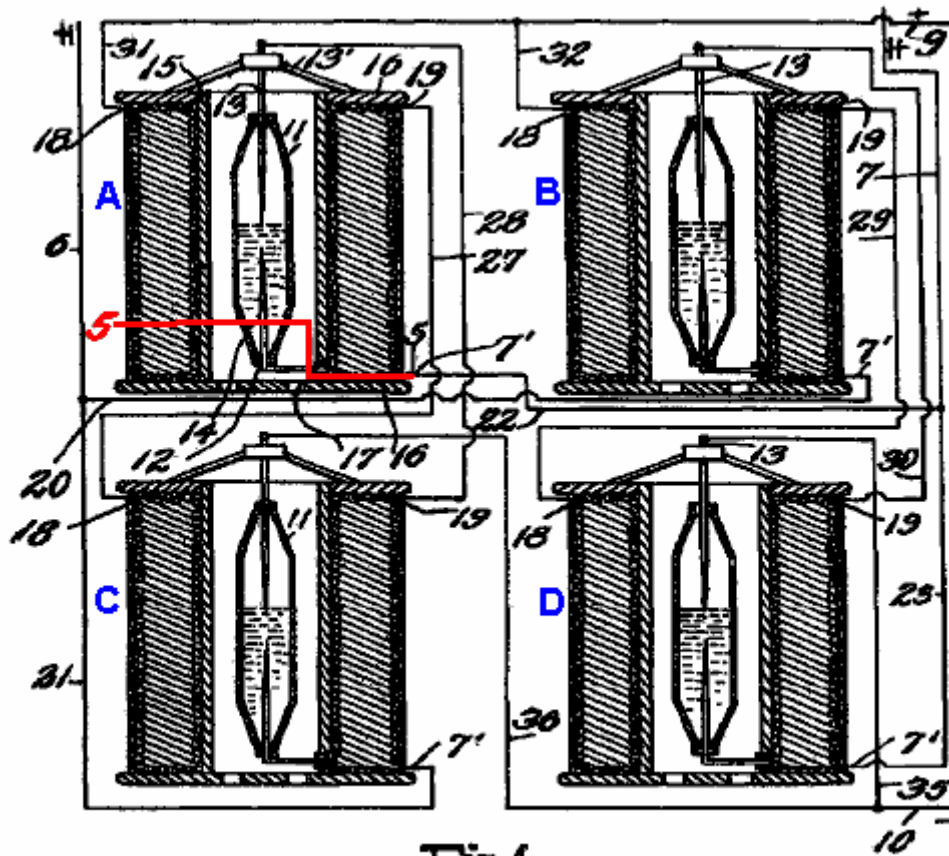

Fig. 4

Fig. 4 is a detail view, partly in elevation and partly in section, showing the connections of the converter and intensifier.

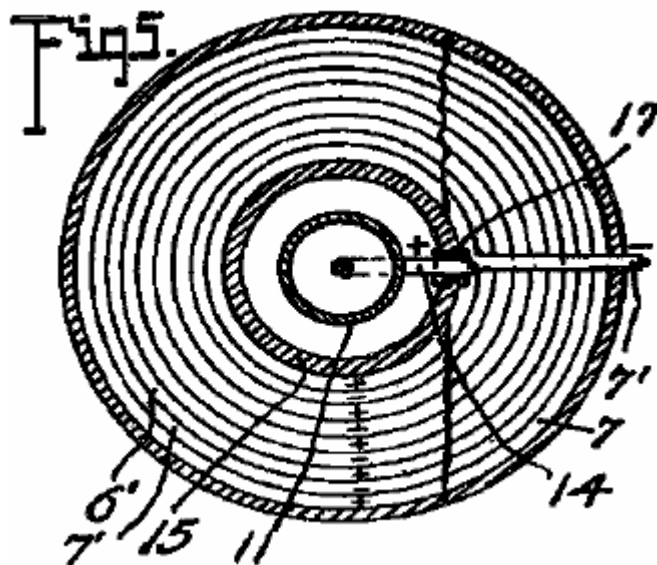

Fig. 5 is a transverse section taken on the planes indicated by line 5-5 of Fig. 4, looking downwards.

Fig.6

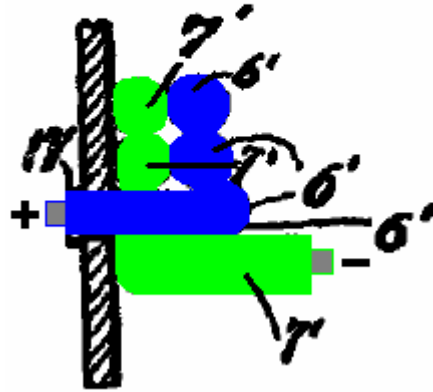

Fig.6 is an enlarged detail fragmentary section illustrating the parts at the junction of the conductors and one of the intensifiers.

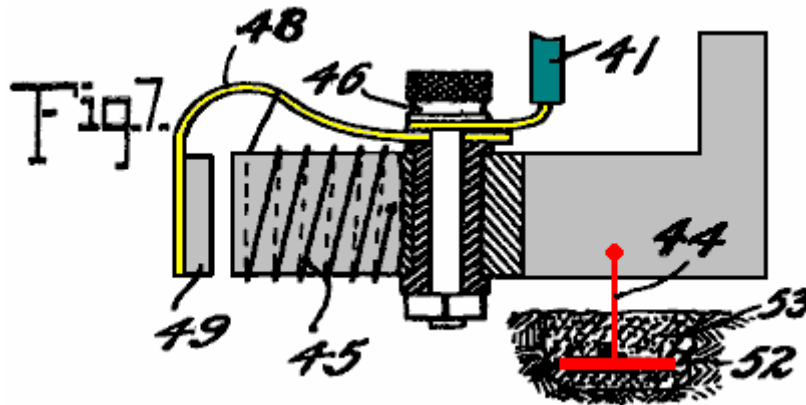

Fig.7 is an enlarged detail view partly in elevation and partly in section of one of the automatic cut-outs

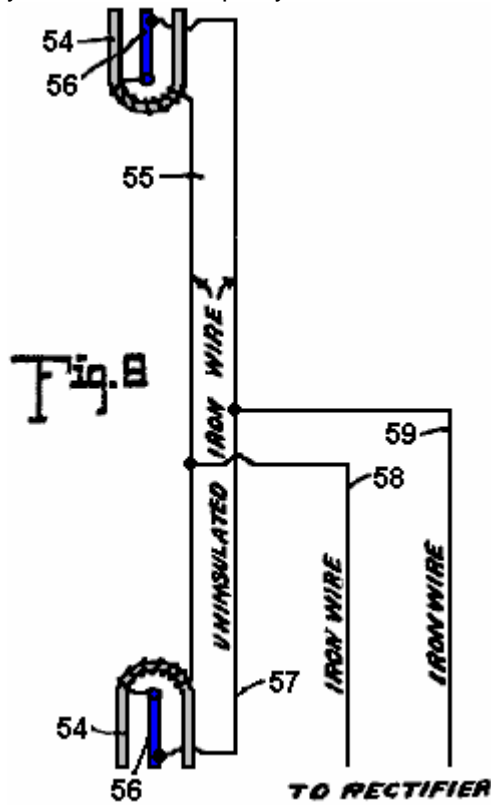
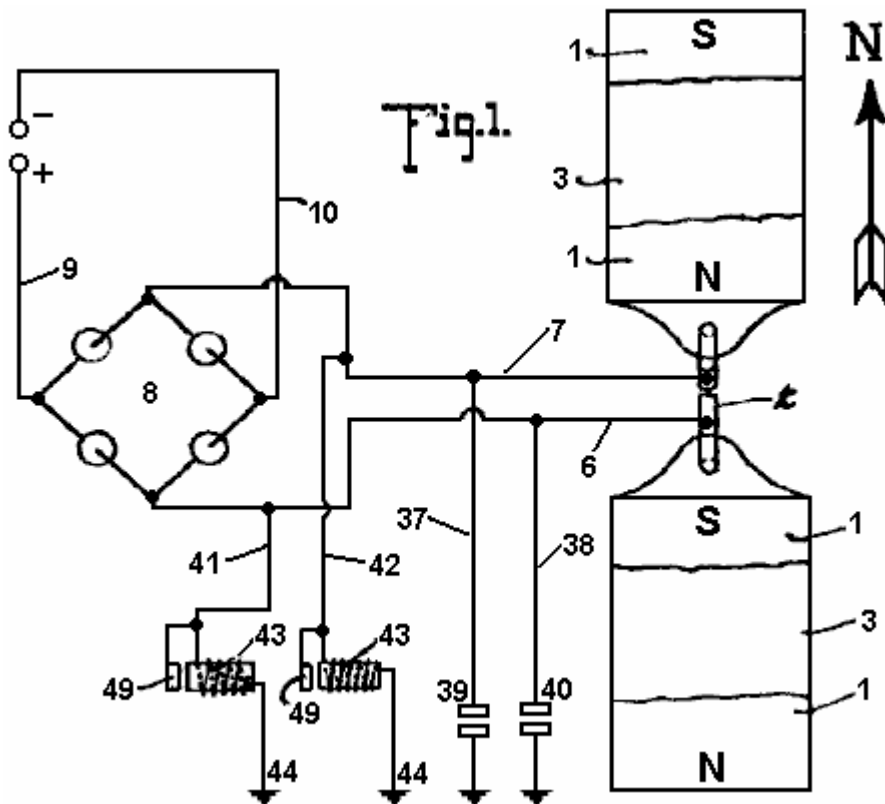

Fig.8 is a diagrammatic view of one of the simplest forms of embodiment of the invention.

Referring to the drawing by numerals, **1,1** indicates magnets connected by a magnetic substance **2**, preferably an iron wire. The magnets **1** are arranged in pairs, one pair being spaced beneath the other, and interposed between the magnets are zinc plates **3,3** connected by an iron wire conductor **4**. Suitable insulating supports **5** are arranged for sustaining the respective magnets **1** and plates **3,3**. Each plate **3** is preferably bent substantially into V form, as clearly seen in **Fig.1**, and the V of one of the plates opens or faces toward the North and the V of the other plate to the South. I have determined by experimentation that it is essential that the plates **3** be disposed substantially North and South with their flat faces approximately parallel to the adjacent faces of the co-operating magnets, although by experience I have not discovered any material difference in the current obtained when the plates are disposed slightly to one side of North and South, as for instance when the plates are disposed slightly to one side of North and South, as for instance when disposed in the line of the magnetic polarity of the earth. The same is true with respect to the magnets **1**, the said magnets being disposed substantially North and South for operative purposes, although I find that it is immaterial whether the North pole of one of the magnets is disposed to the North and the South pole to the South, or vice versa, and it is my conviction from experience that it is essential to have the magnets of each pair connected by magnetic material so that the magnets substantially become one with a pole exposed to the North and a pole exposed to the South.



In **Fig.1**, I have indicated in full lines by the letters **8** and **N** the respective polarities of the magnets **1**, and have indicated in dotted lines the other pole of those magnets when the connection **2** is severed. I have found that the magnets and zinc plates operate to produce, (whether by collection or generation I am not certain), electrical currents when disposed substantially North and South, but when disposed substantially East and West, no such currents are produced. I also find that the question of elevation is by no means vital, but it is true that more efficient results are obtained by placing the zincs and magnets on elevated supports. I furthermore find from tests, that it is possible to obtain currents from the apparatus with the zincs and magnets disposed in a building or otherwise enclosed, although more efficient results are obtained by having them located in the open.

While in **Figures 1, 2, and 3**, I have shown the magnets and the zinc plates as superimposed, it will be apparent, as described in detail below, that these elements may be repositioned in horizontal planes, and substantially the same results will be secured. Furthermore, the magnets **1** with the interposed zincs **3**, as shown in **Figures 1, 2 and 3** merely represent a unit which may be repeated either horizontally or vertically for increasing the current supply, and when the unit is repeated the zinc plates are arranged alternating with the magnets throughout the entire series as indicated below.

A conductor **6** is connected in multiple with the conductors **2** and a conductor **7** is connected with conductor **4**, the conductor **6** extending to one terminal of a rectifier which I have indicated by the general reference character **8**, and the conductor **7** extending to the other terminal of the rectifier. The rectifier as seen in the diagram **Fig.1** may

assume any of several well known embodiments of the electrical valve type and may consist of four asymmetric cells or Cooper-Hewitt mercury vapour lamps connected as indicated in **Fig.1** for permitting communication of the positive impulses from the conductor **6** only to the line conductor **9** and the negative impulses from conductor **6** on only to the line conductor **10**. The current from this rectifier may be delivered through the conductors **9** and **10** to any suitable source for consumption.

While the said rectifier **8** may consist of any of the known types, as above outlined, it preferably consists of a specially constructed rectifier which also has the capacity of intensifying the current and comprises specifically the elements shown in detail in **Figures 4, 5, and 6** wherein I have disclosed the detail wiring of the rectifier when composed of four of the rectifying and intensify in elements instead of asymmetric cells or simple mercury vapour valves. As each of these structures is an exact embodiment of all the others, one only will be described, and the description will apply to all. The rectifying element of each construction consists of a mercury tube **11** which is preferably formed of glass or other suitable material, and comprises a cylinder having its end portions tapered and each terminating in an insulating plug or stopper **12**. Through the upper stopper **12** is extended the electrode **13** which extends well into the tube and preferably about one-half its length, to a point adjacent the inner end of an opposing electrode **14** which latter electrode extends from there down through the insulation **12** at the lower end of the tube. The tube **11** is supplied with mercury and is adapted to operate on the principle of the mercury vapour lamp, serving to rectify current by checking back impulses of one sign and permitting passage of impulses of the other.

To avoid the necessity for utilising a starter, as is common with the lamp type of electrical valve, the supply of mercury within the tube may be sufficient to contact with the lower end of the electrode **13** when current is not being supplied, so that as soon as current is passed from one electrode to the other sufficiently for volatilising that portion of the mercury immediately adjacent the lower end of electrode **13**, the structure begins its operation as a rectifier. The tube **11** is surrounded by a tube **15** which is preferably spaced from tube **11** sufficiently for allowing atmospheric or other cooling circulation to pass the tube **11**. In some instances, it may be desirable to cool the tube **11** by a surrounding body of liquid, as mentioned below. The tube **15** may be of insulating material but I find efficient results attained by the employment of a steel tube, and fixed to the ends of the of the tube are insulating disks **16, 16** forming a spool on which are wound twin wires **6'** and **7'**, the wire **6'** being connected at the inner helix of the coil with the outer end of the electrode **14**, the lower portion of said electrode being extended to one side of the tube **11** and passed through an insulating sleeve **17** extending through the tube **15**, and at its outer end merging into the adjacent end of the wire **6'**. The wire **7'** extends directly from the outer portion of the spool through the several helices to a point adjacent to the junction of the electrode **14** with wire **6'** and thence continues parallel to the wire throughout the coil, the wire **6'** ending in a terminal **18** and the wire **7'** ending in a terminal **19**.

For the sake of convenience of description and of tracing the circuits, each of the apparatus just above described and herein known as an intensifier and rectifier will be mentioned as **A, B, C** and **D**, respectively. Conductor **6** is formed with branches **20** and **21** and conductor **7** is formed with similar branches **22** and **23**. Branch **20** from conductor **6** connects with conductor **7'** of intensifier **B** and branch **21** of conductor **6** connects with the conductor **7'** of intensifier **C**, while branch **22** of conductor **7** of intensifier **C**, while branch **22** of conductor **7** connects with conductor **7'** of intensifier **D**. A conductor **27** is connected to terminal **19** of intensifier **A** and extends to and is connected with the terminal **18** of intensifier **C**, and a conductor **7** connects with conductor **7'** of intensifier **D**. A conductor **27** is connected to terminal **19** of intensifier **A**, and extends to and is connected to terminal **18** of intensifier **C**, and a conductor **28** is connected to the terminal **19** of intensifier **C** and extends from the terminal **19** of intensifier **B** to the terminal **18** of intensifier **D** to electrode **13** of intensifier **B**. Each electrode **13** is supported on a spider **13'** resting on the upper disk **16** of the respective intensifier. Conductors **31** and **32** are connected to the terminals **18** of intensifiers **A** and **B** and are united to form the positive line wire **9** which co-operates with the negative line wire **10** and extends to any suitable point of consumption. The line wire **10** is provided with branches **35** and **36** extending to the electrodes **13** of intensifiers **C** and **D** to complete the negative side of the circuit.

Thus it will be seen that alternating currents produced in the wires **6** and **7** will be rectified and delivered in the form of a direct current through the line wires **9** and **10**, and I find by experiment that the wires **6** and **7** should be of iron, preferably soft, and may of course be insulated, the other wiring not specified as iron being of copper or other suitable material.

In carrying out the operation as stated, the circuits may be traced as follows: A positive impulse starting at the zincs **3** is directed along conductor **7** to branch **23** to conductor **7'** and the winding of the rectifier of intensifier **B** through the rectifier to the conductor **6'**, through its winding to the contact **18**, conductor **32** and to the line wire **9**. The next, or negative, impulse directed along conductor **7** cannot find its way along branch **23** and the circuit just above traced because it cannot pass across the rectifier of intensifier **B** but instead the negative impulse passes along conductor **22** to conductor **7** of intensifier **A** and its winding to the contact **19** and to conductor **27** to contact **18** of intensifier **C**, to the winding of the wire **6'** thereof to the electrode **14** through the rectifier to the of the

electrode **13** and conductor of intensifier **A**, electrode **14** thereof and conductor **6'** to contact **18** and wire **31** to line wire **9**.

Obviously the positive impulse cannot pass along the wire **20** because of its inverse approach to the rectifier of intensifier **B**. The next impulse or negative impulse delivered to conductor **6** cannot pass along conductor **21** because of its connection with electrode **13** of the rectifier of intensifier **A**, but instead passes along conductor **20** to the wire **7'** and its winding forming part of intensifier **B** to the contact **19** and conductor **29** to contact **18** and the winding of wire **6'** of intensifier **D** to the electrode **14** and through the rectifier to the electrode **13** and conductor **35** to line wire **10**. Thus the current is rectified and all positive impulses directed along one line and all negative impulses along the other lie s that the potential difference between the two lines will be maximum for the given current of the alternating circuit. It is, of course, apparent that a less number of intensifiers with their accompanying rectifier elements may be employed with a sacrifice of the impulses which are checked back from a lack of ability to pass the respective rectifier elements, and in fact I have secured efficient results by the use of a single intensifier with its rectifier elements, as shown below.

Grounding conductors **37** and **38** are connected respectively with the conductors **6** and **7** and are provided with the ordinary lightning arresters **39** and **40** respectively for protecting the circuit against high tension static charges.

Conductors **41** and **42** are connected respectively with the conductors **6** and **7** and each connects with an automatic cut-out **43** which is grounded as at **4**. Each of the automatic cut-outs is exactly like the other and one of the these is shown in detail in **Fig.7** and comprises the inductive resistance **45** provided with an insulated binding post **46** with which the respective conductor **6** or **7** is connected, the post also supporting a spring **48** which sustains an armature **49** adjacent to the core of the resistance **45**. The helix of resistance **45** is connected preferably through the spring to the binding post at one end and at the other end is grounded on the core of the resistance, the core being grounded by ground conductor **44** which extends to the metallic plate **52** embedded in moist carbon or other inductive material buried in the earth. Each of the conductors **41**, **42** and **44** is of iron, and in this connection I wish it understood that where I state the specific substance I am able to verify the accuracy of the statement by the results of tests which I have made, but of course I wish to include along with such substances all equivalents, as for instance, where iron is mentioned its by-products, such as steel, and its equivalents such as nickel and other magnetic substances are intended to be understood.

The cut-out apparatus seen in detail in **Fig.7** is employed particularly for insuring against high voltage currents, it being obvious from the structure shown that when potential rises beyond the limit established by the tension of the spring sustaining the armature **40**, the armature will be moved to a position contacting with the core of the cut-out device and thereby directly close the ground connection for line wire **41** with conductor **44**, eliminating the resistance of winding **45** and allowing the high voltage current to be discharged to the ground. Immediately upon such discharge the winding **45** losing its current will allow the core to become demagnetised and release the armature **49** whereby the ground connection is substantially broken leaving only the connection through the winding **45** the resistance of which is sufficient for insuring against loss of low voltage current.

In **Fig.8** I have illustrated an apparatus which though apparently primitive in construction and arrangement shows the first successful embodiment which I produced in the course of discovery of the present invention, and it will be observed that the essential features of the invention are shown there. The structure shown in the figure consists of horseshoe magnets **54**, **55**, one facing North and the other South, that is, each opening in the respective directions indicated and the two being connected by an iron wire **55** which is uninsulated and wrapped about the respective magnets each end portion of the wire **55** being extended from the respective magnets to and connected with, as by being soldered to, a zinc plate **56**, there being a plate **56** for each magnet and each plate being arranged longitudinally substantially parallel with the legs of the magnet and with the faces of the plate exposed toward the respective legs of the magnet, the plate being thus arranged endwise toward the North and South. An iron wire **57** connects the plates **56**, the ends of the wire being preferably connected adjacent the outer ends of the plates but from experiment I find that the wire may be connected at practically any point to the plate. Wires **58** and **59** are connected respectively with the wires **55** and **57** and supply an alternating current at a comparatively low voltage, and to control such current the wires **58** and **59** may be extended to a rectifier or combined rectifier and intensifier, as discussed above.

The tests which I have found successful with the apparatus seen in **Fig.8** were carried out by the employment first of horseshoe magnets approximately 4 inches in length, the bar comprising the horseshoe being about one inch square, the zincs being dimensioned proportionately and from this apparatus with the employment of a single intensifier and rectifier, as above stated, I was able to obtain a constant output of 8 volts.

It should be obvious that the magnets forming one of the electrodes of this apparatus may be permanent or may be electromagnets, or a combination of the two.

While the magnets mentioned throughout the above may be formed of any magnetic substance, I find the best results obtained by the employment of the nickel chrome steel.

While the successful operation of the various devices which I have constructed embodying the present invention have not enabled me to arrive definitely and positively at fixed conclusion relative to the principles and theories of operation and the source from which current is supplied, I wish it to be understood that I consider myself as the first inventor of the general type described above, capable of producing commercially serviceable electricity, for which reason my claims hereinafter appended contemplate that I may utilise a wide range of equivalents so far as concerns details of construction suggested as preferably employed.

The current which I am able to obtain is dynamic in the sense that it is not static and its production is accomplished without chemical or mechanical action either incident to the actual chemical or mechanical motion or incident to changing caloric conditions so that the elimination of necessity for the use of chemical or mechanical action is to be considered as including the elimination of the necessity for the use of heat or varying degrees thereof.

PAULO and ALEXANDRA CORREA

Pat. Application US 2006/0082,334 20th April 2006 Inventors: Paulo & Alexandra Correa

ENERGY CONVERSION SYSTEMS

This patent application shows the details of devices which can produce ordinary electricity from Tesla longitudinal waves. If these claims are correct (and there does not appear to be the slightest reason for believing that they are not), then implementations of this patent application are capable of producing free electrical power and the importance of this information is enormous.

ABSTRACT

This invention relates to apparatus for the conversion of mass-free energy into electrical or kinetic energy, which uses in its preferred form a transmitter and a receiver both incorporating Tesla coils, the distal ends of whose secondary windings are co-resonant and connected to plates of a chamber, preferably evacuated or filled with water, such that energy radiated by the transmitter may be picked up by the receiver, the receiver preferably further including a pulsed plasma reactor driven by the receiver coil and a split phase motor driven by the reactor. Preferably the reactor operates in pulsed abnormal gas discharge mode, and the motor is an inertially dampened drag motor. The invention also extends to apparatus in which an otherwise driven plasma reactor operating in pulsed abnormal gas discharge mode in turn used to drive an inertially dampened drag motor.

DESCRIPTION

This is a continuation of application Ser. No. 09/907,823, filed Jul. 19, 2001.

FIELD OF THE INVENTION

This invention relates to systems for the conversion of energy, inter alia in the form of what we will refer to for convenience as Tesla waves (see below), to conventional electrical energy.

BACKGROUND OF THE INVENTION

Energy converters that are fed by local or environmental energy are usually explained by taking recourse to the notion that they convert zero point electromagnetic radiation (ZPE) to electric energy. The ZPE theories have gained a life of their own, as T. Kuhn has pointed out (in his "Black Body Theory and the Quantum"), after emerging from Planck's second theory, specifically from the term $\frac{1}{2} h\nu$ in the new formula for oscillator energy. In 1913, Einstein and Stern suggested that motional frequencies contributing to specific heat fell into two categories--those that were independent of temperature and those that were not (e.g. rotational energy), leading them to conclude that zero-point energy on the order of $\frac{1}{2} h\nu$ was most likely. In the second part of their paper, however, they provided a derivation of Planck's Law without taking recourse to discontinuity, by assuming that the value of the ZPE was simply $h\nu$. It is worth noting that Einstein had already in 1905 ("Erzeugung und Verwandlung des Lichtes betreffenden heuristischen Gesichtspunkt", Ann. d. Phys, 17, 132) framed the problem of discontinuity, even if only heuristically, as one of placing limits upon the infinite energy of the vacuum state raised by the Rayleigh-Jeans dispersion law. According to Einstein, the Rayleigh-Jeans law would result in an impossibility, the existence of infinite energy in the radiation field, and this was precisely incompatible with Planck's discovery - which suggested instead, that at high frequencies the entropy of waves was replaced by the entropy of particles. Einstein, therefore, could only hope for a stochastic validation of Maxwell's equations at high frequencies "by supposing that electromagnetic theory yields correct time-average values of field quantities", and went on to assert that the vibration-energy of high frequency resonators is exclusively discontinuous (integral multiples of $h\nu$).

Since then, ZPE theories have gone on a course independent from Planck's second theory. The more recent root of modern ZPE theories stems from the work of H. Casimir who, in 1948, apparently showed the existence of a force acting between two uncharged parallel plates. Fundamentally the Casimir effect is predicated upon the existence of a background field of energy permeating even the "vacuum", which exerts a radiation pressure, homogeneously and from all directions in space, on every body bathed in it. Given two bodies or particles in proximity, they shield one another from this background radiation spectrum along the axis (i.e. the shortest distance) of their coupling, such that the radiation pressure on the facing surfaces of the two objects would be less than the radiation pressure experienced by all other surfaces and coming from all other directions in space. Under these conditions, the two objects are effectively pushed towards one another as if by an attractive force. As the distance separating the two objects diminishes, the force pushing them together increases until they collapse one on to the other. In this sense, the Casimir effect would be the macroscopic analogy of the microscopic van der Waals forces of attraction responsible for such dipole-dipole interactions as hydrogen bonding. However, it is worth noting that the van der Waals force is said to tend to establish its normal radius, or

the optimal distance between dipoles, as the distance where the greatest attractive force is exerted, beyond which the van der Waals forces of nuclear and electronic repulsion overtake the attraction force.

Subsequently, another Dutch physicist, M. Sparnaay, demonstrated that the Casimir force did not arise from thermal radiation and, in 1958, went on to attribute this force to the differential of radiation pressure between the ZPE radiation from the vacuum state surrounding the plates and the ZPE radiation present in the space between them. Sparnaay's proposal is that a classical, non-quantal, isotropic and ubiquitous electromagnetic zero-point energy exists in the vacuum, and even at a temperature of absolute zero. It is further assumed that since the ZPE radiation is invariant with respect to the Lorentz transformations, it obeys the rule that the intensity of its radiation is proportional to the cube of the frequency, resulting in an infinite energy density for its radiation spectrum.

What appeared to be the virtue of this reformulated theory was the notion that the vacuum no longer figured as pure space empty of energy, but rather as a space exposed to constantly fluctuating "fields of electromagnetic energy".

Puthoff has utilised the isomorphism between van der Waals and Casimir forces to put forth the zero-point (ZP) energy theory of gravity, based on the interpretation that the virtual electromagnetic ZP field spectrum predicted by quantum electrodynamics (QED) is functionally equivalent to an actual vacuum state defined as a background of classical or Maxwellian electromagnetic radiation of random phases, and thus can be treated by stochastic electrodynamics (SED). Whereas in QED, the quanta are taken as virtual entities and the infinite energy of the vacuum has no physical reality, for SED, the ZPE spectrum results from the distortion of a real physical field and does not require particle creation. Gravity then, could be seen as only the macroscopic manifestation of the Casimir force.

We do not dispute the fact that even in space-absent matter, there is radiant energy present which is not of a thermal nature. But we claim that this energy is not electromagnetic, nor is its energy spectrum-infinite. That this is so, stems not just from our opinion that it is high time that Einstein's heuristic hypothesis should be taken as literally factual - in the dual sense that all electromagnetic energy is photon energy and all photons are local productions, but above all from the fact that it is apparent, from the experiments of Wang and his colleagues (Wang, Li, Kuzmich, A & Dogariu, A. "Gain-assisted superluminal light propagation", Nature 406; #6793; 277), that the photon stimulus can propagate at supraluminal speeds and lies therefore well outside of any scope of electromagnetic theory, be this Maxwell's classical approach taken up by ZPE theories, or Einstein's special relativistic phenomenology of Maxwell's theory. The fact is, that if the light stimulus can propagate at speeds greater than those of light, then what propagates is not light at all, and thus not energy configured electromagnetically. Light is solely a local production of photons in response to the propagation of a stimulus that itself is not electromagnetic.

It is critical to understand that the implication from this, that - aside from local electromagnetic radiation and from thermal radiation associated with the motions of molecules (thermo-mechanical energy), there is at least one other form of energy radiation which is everywhere present, even in space-absent matter. Undoubtedly, it is that energy which prevents any attainment of absolute zero, for any possible local outpumping of heat is matched by an immediate local conversion of some of this energy into a minimum thermal radiation required by the manifolds of Space and Time. Undoubtedly also, this radiation is ubiquitous and not subject to relativistic transformations (i.e. it is Lorentz invariant). What it is not, is electromagnetic radiation consisting of randomistic phases of transverse waves.

To understand this properly, one must summarise the differences from existing ZPE theories - and all these differences come down to the fact that this energy, which is neither electromagnetic nor thermal per se, (and is certainly not merely thermo-mechanical), has nevertheless identifiable characteristics both distributed across sub-types or variants and also common to all of them.

Essentially, the first sub-type or variant consists of longitudinal mass-free waves which deploy electric energy. They could well be called Tesla waves, since Tesla-type transformers can indeed be shown experimentally to radiate mass-free electric energy, in the form of longitudinal magnetic and electric waves having properties not reducible to photon energy nor to "electromagnetic waves", and having speeds of displacement which can be much greater than the limit c for all strictly electromagnetic interactions.

One may well denote the second sub-type by the designation of mass-free thermal radiation, since it contributes to temperature changes - and, as obviously indicated by the impossibility of reaching an absolute zero of temperature, this contribution occurs independently of the presence of matter, or mass-energy, in Space. In other words, not all thermal radiation can be reduced to vibration, rotation and translation (drift motion) of molecules, i.e. to thermomechanical energy, because the properties of pressure and volume which determine temperature and affect matter, appear indeed to a great extent to be independent from matter, a fact which itself is responsible for the observed catastrophic and unexpected phase changes of matter and has required to this day the insufficient explanation offered semi-empirically by the Van der Waals Force Law.

Finally, the third sub-type may be designated latent mass-free energy radiation - since it deploys neither charge, nor thermal or baroscopic effects, and yet it is responsible for "true latent heat" or for the "intrinsic potential energy" of a molecule. It is also responsible for the kinto-regenerative phenomenon whereby an electroscope performs a variable charge-mediated work against the local gravitational field.

The common characteristic of all three sub-types of mass-free energy radiation is that they share the same non-classical fine structure, written as follows for any energy unit, where \mathbf{c} is any speed of light wave function, and the wavelength λ and wave function \mathbf{W} are interconnected as a function of the physical quality of the energy field under consideration: $E = \lambda \mathbf{c} \mathbf{W}$

In the instance of longitudinal electric radiation, this takes on the directly quantifiable form:

$$E = (\lambda_q \mathbf{c}) W_v = p_c W_v = (h/\lambda_x) W_v = \int = qV$$

where:

\mathbf{W}_v is the voltage-equivalent wave function corresponding to V ,

\mathbf{P}_e constitutes the linear momentum corresponding to the conventional q or e ,

h is the Planck constant,

λ_x is the Duane-Hunt constant expressed as a wavelength,

λ_q is a wavelength constant; and the sign

$= \int =$ signifies exact equality between an expression in the conventional dimensions of length, mass and time, and an expression in length and time dimensions alone.

In the instance of mass-free thermal radiation (contributing to temperature changes), the transformation obeys Boltzmann's rule (k is now Boltzmann's constant and T is Kelvin-scale temperature):

$$E = \lambda_{n1} \mathbf{c} W_{n1} = \lambda_{n1} (\pi_V \xi_P) (\lambda_{n1}) \sim kT$$

and in the third instance - of latent mass-free radiation, the transformation obeys the rule:

$$E = \lambda_{n1} \mathbf{c} W_{n1} = \lambda_{n1} (\lambda_{n1} \xi_{n1}) (\lambda_{n1} f_{n1}) = \lambda_{n1}^3 \xi_{n1} f_{n1}$$

where ξ and f are frequency functions, f being a specific gravitational frequency term, and f_{n1} being defined as equal to $(\lambda_{n1})^{-0.5} \text{meter}^{0.5} \text{sec}^{-1}$ and ξ_{n1} has the value of c/λ_{n1}

If the electric variant of mass-free radiation has a direct quantum equivalence, via the Duane-Hunt Law, none of the three primary aether energy variants possess either the classic form of electromagnetic energy which requires square superimposition of speed of light wave functions \mathbf{c} , as \mathbf{c}^2 , or the quantum form of energy, requiring $E = h\nu$. The critical first step in the right direction may well be attributed to Dr. W. Reich, as it regards the fact that mass-free energy couples two unequal wave functions, only one of which is electromagnetic and abides by the limit \mathbf{c} . We then unravelled the threefold structure described above, and further showed that, in the case of longitudinal electric waves, the postulated equivalence ($q = \lambda_q \mathbf{c}$) is merely phenomenological, as these waves are not restricted by the function \mathbf{c} in their conveying of electric charge across space. It can further be demonstrated that all black-body photons are bound by an upper frequency limit (64×10^{14} Hz), above which only ionising photons are produced, and that all black-body photons arise precisely from the interaction of mass-free electric radiation with molecules of matter (including light leptons), whereby the energy of that radiation is locally converted into photon or electromagnetic radiation. In other words, all non-ionising electromagnetic energy appears to be secondary energy which results locally from the interaction of matter with mass-free electric energy. It cannot therefore consist of the primary energy that is present in the vacuum, an energy that is neither virtual nor electromagnetic, but actual and concrete in its electric, thermal and antigravitic manifestations. Lastly, gravitational energy, being either the potential or the kinetic energy responsible for the force of attraction between units of matter, is a manifestation that also requires, much as electromagnetic radiation does, coupling of mass-free energy to matter or to mass-energy.

The Tesla coil is a generator of a mass-free electric energy flux which it transmits both by conduction through the atmosphere and by conduction through the ground. Tesla thought it did just that, but it has been since regarded instead (because of Maxwell, Hertz and Marconi) as a transmitter of electromagnetic energy. The transmitter operates by a consumption of mass-bound electric power in the primary, and by induction it generates in the

coupled secondary two electric fluxes, one mass-bound in the coil conductor, and the other mass-free in the body of the solenoid. Tesla also proposed and demonstrated a receiver for the mass-free energy flux in the form of a second Tesla coil resonant with the first. The receiver coil must be identical and tuned to the transmitter coil; the capacitance of the antenna plate must match that of the transmitter plate; both transmitter and receiver coils must be grounded; and the receiver coil input and output must be unipolar, as if the coil were wired in series.

The generators of mass-free energy with which we are concerned, provide current pulses associated with a dampened wave (DW) oscillation of much higher frequency than the pulse repetition frequency. A particular problem in recovering the mass-free energy content of such pulses is provided by the dampened wave oscillations. Although in our U.S. Pat. No. 5,416,391 we describe arrangements incorporating split phase motors to recover such energy, their efficiency is a great deal less than what should theoretically be attainable. Other workers such as Tesla and Reich, have encountered the same problem to an even greater degree.

In nineteenth century motor engineering terminology, dynamos capable of producing direct current by continuous homopolar induction were known as "unipolar" generators. The term "unipolar induction" appears to have originated with W. Weber, to designate homopolar machines where the conductor moves continuously to cut the magnetic lines of one kind of magnetic pole only, and thus require sliding contacts to collect the generated current. Faraday's rotating copper disc apparatus was, in this sense, a homopolar generator when the disc was driven manually, or a homopolar motor when the current was provided to it. Where the rotating conductor continuously cuts the magnetic field of alternately opposite magnetic poles, the operation of a machine, whether a generator or a motor, is said to be "heteropolar". Unipolar machines went on to have a life of their own in the form of low voltage and high current DC generators - from Faraday, through Plucker, Varley, Siemens, Ferraris, Hummel, to Lord Kelvin, Pancinoti, Tesla and others - almost exclusively in the form of disc dynamos, but some having wound rotors.

In Mordey's alternator, and in so-called "inductor alternators", however, homopolar generators were employed to obtain alternating currents, with the use of rotors wound back and forth across the field. Use of smooth, unwound rotors in AC induction motors (as opposed to AC synchronous motors, such as hysteresis motors) was a later development than homopolar dynamos. By 1888, Tesla and Ferraris amongst still others, had independently produced rotating magnetic fields in a motor, by employing two separate alternate currents with the same frequency but different phase. Single phase alternate current motors were developed later, and split-phase motors were developed last. Ferraris (Ferraris, G (1888) "Rotazioni elettrodinamiche", Turin Acad, March issue.) proposed the elementary theory of the 2-phase motor, where the current induced in the rotor is proportional to the slip (the difference between the angular velocity of the magnetic field and that of the rotating cylinder), and the power of the motor is proportional to both the slip and the velocity of the rotor.

If an iron rotor is placed within the rotating magnetic field of a 2-phase stator, it will be set in rotation, but not synchronously, given that it is always attracted to the moving magnetic poles with a lag. But if an aluminium or copper rotor is used instead, it gets "dragged" around by the rotating stator field because of the eddy currents induced in it. If the aluminium or copper rotor were to rotate synchronously with the stator magnetic field, there would be no induced eddy currents and thus no motor action would result. The motor action depends, in this instance, upon the presence of asynchronous slip, since the function of the latter is to sustain the induction of those currents in the rotor that are responsible for the motor action of the dragged rotor. This then is the origin of the term "AC drag motors". Once the drag rotor evolved from a cylinder to a hollow cup, they earned the epithet of "drag-cup motors". Later, already in the 20th century, the cups were fitted over a central stator member, and the sleeve rotor 2-phase servo motor was born.

Tesla knew that impulse currents as well as CW (constant wave) sinusoidal currents could be used to drive AC motors. Regarding his invention of a hysteresis motor (which he called a "magnetic lag motor"), he stated: ". . . pulsatory as well as an alternating current might be used to drive these motors . . ." (Martin, T C (1894) "The inventions, researches and writings of Nikola Tesla", Chapter XII, p. 68). In his search for efficient utilisation of the high frequency DW (dampened wave) impulse currents of his induction coils, Tesla began by employing an AC disc induction motor as shown in Fig.17 of his famous 1892 address (Tesla, N (1892) "Experiments with alternate currents of high potential and high frequency", in "Nikola Tesla Lectures", 1956, Beograd, pp. L-70-71). This consisted of a copper or aluminium disc mounted vertically along the longitudinal axis of an iron core on which was wound a single motor coil which was series wired to the distal terminal of an induction coil at one end, and to a large suspended and insulated metal plate at the other. What was new about this was the implementation of an AC disc induction motor drive, where the exciting current travelled directly through the winding with just a unipolar connection to the coil secondary (under certain conditions, even the series connection to the plate could be removed, or replaced with a direct connection to the experimenter's body): "What I wish to show you is that this motor rotates with one single connection between it and the generator" (Tesla, N. (1892), op. cit., L-70, Tesla's emphasis). Indeed, he had just made a critical discovery that, unlike in the case of mass-bound charge where current flow requires depolarisation of a bipolar tension, mass-free charge engages current flow unipolarly as a mere matter of proper phase synchronisation:

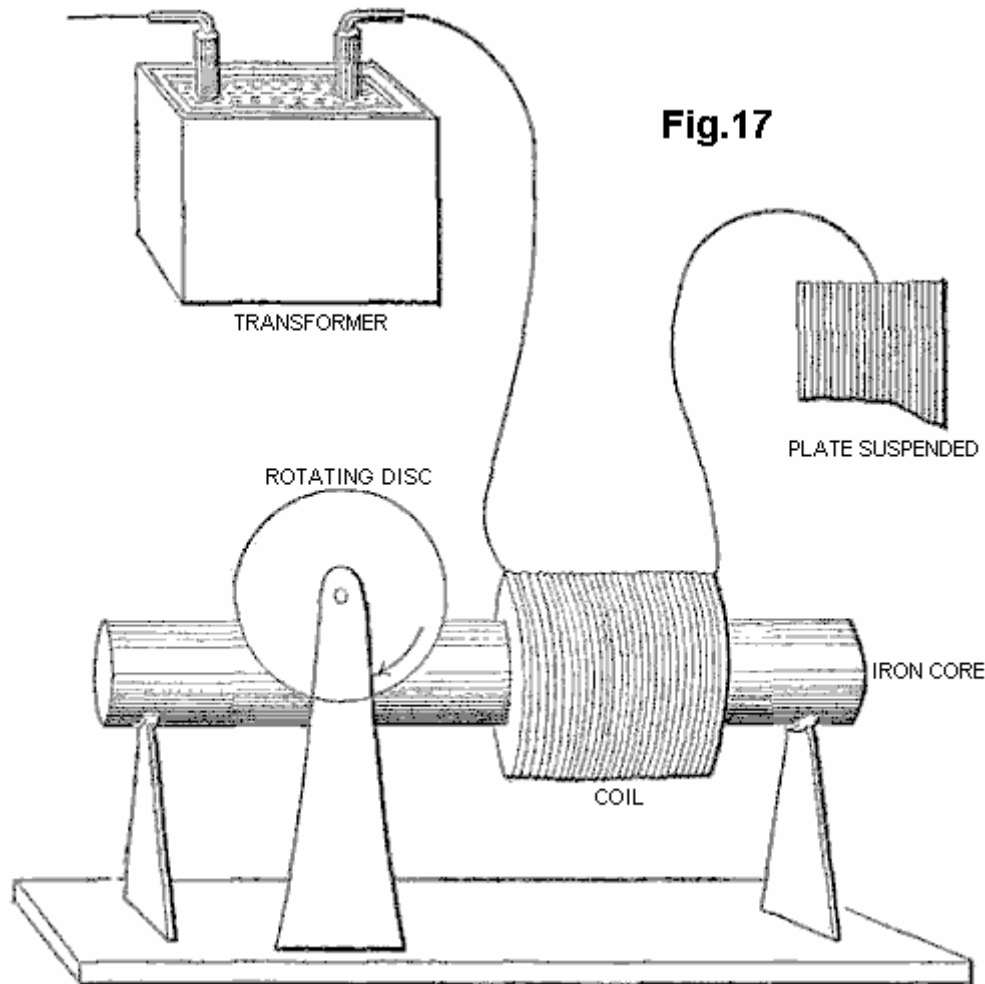

Fig.17

Tesla thought that his motor was particularly adequate to respond to windings which had "high-self-induction", such as a single coil wound on an iron core. The basis of this self-induction is the magnetic reaction of a circuit, or an element of a circuit - an inductor - whereby it chokes, dims or dampens the amplitude of electric waves and retards their phase.

For the motor to respond to still higher frequencies, one needed to wind over the primary motor winding, a partial overlap secondary, closed through a capacitor, since "it is not at all easy to obtain rotation with excessive frequencies, as the secondary cuts off almost completely the lines of the primary" (Idem, L-71.).

Tesla stated that "an additional feature of interest about this motor" was that one could run it with a single connection to the earth ground, although in fact one end of the motor primary coil had to remain connected to the large, suspended metal plate, placed so as to receive or be bathed by "an alternating electrostatic field", while the other end was taken to ground. Thus Tesla had an ordinary induction coil that transmitted this "alternating electrostatic field", an untuned Tesla antenna receiving this "field", and a receiver circuit comprising his iron-core wound motor primary, a closely coupled, capacitatively closed secondary, and the coupled non-ferromagnetic disc rotor. Eventually, in his power transmission system, he would replace this transmitter with a Tesla coil, and place an identical receiving coil at the receiving end, to tune both systems and bring them into resonance. But his motor remained undeveloped, and so did the entire receiver system.

Tesla returned to this subject a year later, saying "on a former occasion I have described a simple form of motor comprising a single exciting coil, an iron core and disc" (Tesla, N (1893) "On light and other high frequency phenomena", in "Nikola Tesla Lectures", 1956, Beograd, pp. L-130, and L-131 with respect to Fig.16-II). He describes how he developed a variety of ways to operate such AC motors unipolarly from an induction transformer, and as well other arrangements for "operating a certain class of alternating motors founded on the action of currents of differing phase". Here, the connection to the induction transformer is altered so that the motor primary is driven from the coarse secondary of a transformer, whose finer primary is coupled, at one end, directly and with a single wire to the Tesla secondary, and at the other left unconnected. On this occasion, Tesla mentions that such a motor has been called a "magnetic lag motor", but that this expression (which, incidentally, he had himself applied to his own invention of magnetic hysteresis motors) is objected to by "those who attribute the rotation of the disc to eddy currents when the core is finally subdivided" (Tesla, N (1893), op. cit., p. L-130).

In none of the other motor solutions, 2-phase or split-phase, that he suggests as unipolar couplings to the secondary of an induction coil, does the non-ferromagnetic disc rotor motor again figure. But he returns to it a page later, and indirectly so, by first addressing the disadvantages of ferromagnetic rotors: "Very high frequencies are of course not practicable with motors on account of the necessity of employing iron cores. But one may use sudden discharges of low frequency and thus obtain certain advantages of high-frequency currents-without rendering the iron core entirely incapable of following the changes and without entailing a very great expenditure of energy in the core. I have found it quite practicable to operate, with such low frequency disruptive discharges of condensers, alternating-current motors."

In other words--whereas his experiments with constant wave (CW) alternating currents, and as well with high-voltage dampened wave (DW) impulses from induction coils, indicated the existence of an upper frequency limit to iron core motor performance, one might employ instead high-current, DW impulses - of high DW frequencies but low impulse rates - to move these motors quite efficiently. Then he adds "A certain class of [AC] motors which I advanced a few years ago, that contain closed secondary circuits, will rotate quite vigorously when the discharges are directed through the exciting coils. One reason that such a motor operates so well with these discharges is that the difference of phase between the primary and secondary currents is 90 degrees, which is generally not the case with harmonically rising and falling currents of low frequency. It might not be without interest to show an experiment with a simple motor of this kind, inasmuch as it is commonly thought that disruptive discharges are unsuitable for such purposes."

What he proposes next, forms the basis of modern residential and industrial AC electric power meters, the AC copper disc motor whose rotor turns on the window of these meters, propelled forward by the supply frequency. But instead of employing any such Constant Wave input, Tesla uses the disruptive discharges of capacitors, incipiently operating as current rectifiers. With the proper conditions, e.g. correct voltage from the generator, adequate current from the capacitor, optimum capacitance for the firing rate, and tuned spark-gap, to mention a few, Tesla found that the non-ferromagnetic disc rotor turned but with considerable effort. But this hardly compared to the results obtained with a high-frequency CW alternator, which could drive the disc "with a much smaller effort". In summary then, Tesla went as far as being the first to devise a motor driven by Tesla waves, that employed a non-ferromagnetic rotor, and whose arrangement encompassed both transmitter and receiver circuits. For this purpose, he employed a single-phase method in which the signal is fed unipolarly to the winding, placed in series with a plate capacitance.

Tesla also later proposed driving a similar single-phase non-ferromagnetic disc motor from bipolar capacitive discharges through an atmospheric spark-gap now placed in parallel with the main motor winding, and again simulating a split-phase by a closely-wound secondary which was closed by a capacitance.

As Tesla admits, the results of all his AC eddy current motor solutions were meagre and limited by current and frequency problems. Likewise, the two-phase arrangements proposed by Reich for his OR motor, involving a superimposition of the Dampened Waves of a first phase on a fixed Continuous Wave second phase, require an external power source and a pulse amplifier circuit, and failed to meet Reich's own requirements.

We have previously proposed the use of squirrel cage motors with capacitive splitting of phase to convert the Dampened Wave output of plasma pulsers, but once a Squirrel Cage is introduced, the dampening effect which the non-ferromagnetic copper cage exerts in being dragged by the revolving stator field, is counteracted by the ferromagnetic cylinder of laminated iron, in which the copper cage is embedded, working to diminish the slip and bring the rotor to near synchronism. This is, in all likelihood, what limits Squirrel Cage motors responding to the DC component of the Dampened Wave impulse, and thus be limited to respond to fluxes of mass-bound charges. Historically, as we shall see, the obvious advantage of the Squirrel Cage servo motors lay in the fact that, in particular for 2-phase applications, they were far more efficient at performing work without evolution of heat. Indeed, if the eddy currents in the non-ferromagnetic rotor are permitted to circulate in non-ordered form, the rotor material and stator will heat up rapidly and consume much power in that heating. This is in fact considered to be a weakness of AC non-ferromagnetic-rotor induction motors.

SUMMARY OF THE INVENTION

The present invention is concerned with conversion to conventional electrical energy of the variants of mass-free energy radiation considered above, referred to for convenience as Tesla waves, mass-free thermal radiation and latent mass-free radiation. The first variant of such radiation was recognised, generated and at least partially disclosed by Tesla about a hundred years ago, although his work has been widely misinterpreted and also confused with his work on the transmission of radio or electromagnetic waves. The Tesla coil is a convenient generator of such radiation, and is used as such in many of the embodiments of our invention described below, but it should be clearly understood that our invention in its broadest sense is not restricted to the use of such a coil as a source of mass-free radiation and any natural or artificial source may be utilised. For example, the sun is

a natural source of such radiation, although interaction with the atmosphere means that it is largely unavailable at the earth's surface, limiting applications to locations outside of the earth's atmosphere.

According to the invention, a device for the conversion of mass-free radiation into electrical or mechanical energy comprises a transmitter of mass-free electrical radiation having a dampened wave component, a receiver of such radiation tuned to resonance with the dampened wave frequency of the transmitter, a co-resonant output circuit coupled into and extracting electrical or kinetic energy from the receiver, and at least one structure defining a transmission cavity between the transmitter and the receiver, a full-wave rectifier in the co-resonant output circuit, and an oscillatory pulsed plasma discharge device incorporated in the co-resonant output circuit. The output circuit preferably comprises a full-wave rectifier presenting a capacitance to the receiver, or an electric motor, preferably a split-phase motor, presenting inductance to the receiver. The transmitter and receiver each preferably comprise a Tesla coil and/or an autogenous pulsed abnormal glow discharge device. The transmission cavity is preferably at least partially evacuated, and comprises spaced plates connected respectively to the farthest out poles of the secondaries of Tesla coils incorporated in the transmitter and receiver respectively, the plates being parallel or concentric. The structure defining the cavity may be immersed in ion-containing water. The split-phase motor is preferably an inertially-dampened AC drag motor.

The invention, and experiments demonstrating its basis, are described further below with reference to the accompanying drawings.

SHORT DESCRIPTION OF THE DRAWINGS

Fig.1 is a schematic view of a Tesla coil connected to a full-wave rectifier to form an energy conversion device:

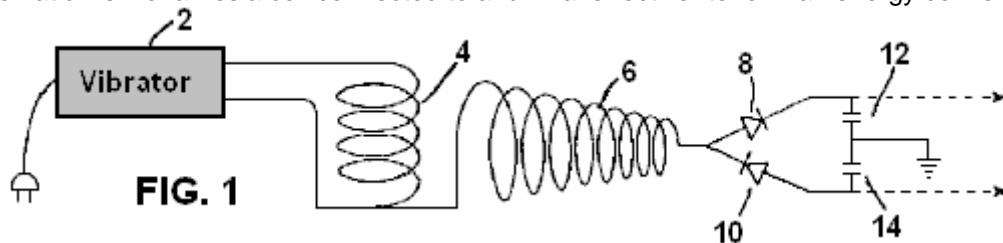

Fig.2 is a schematic view of a Tesla coil connected to a gold leaf electrometer:

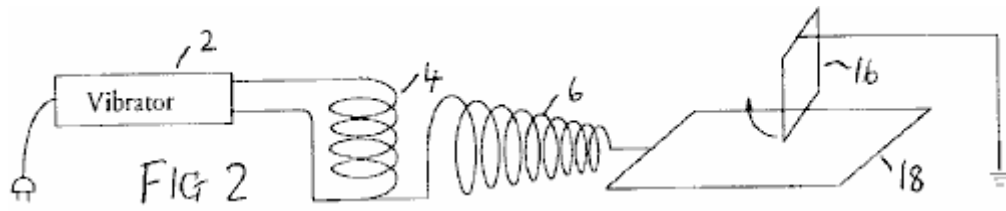
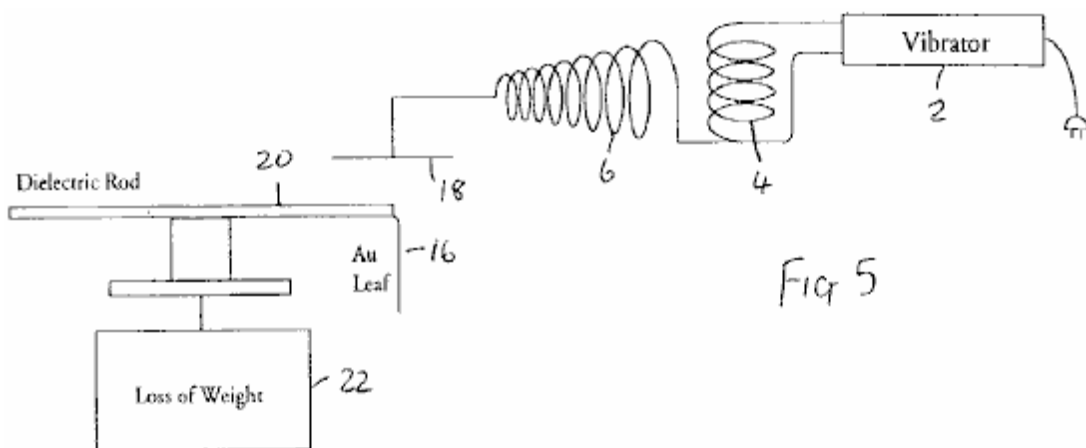
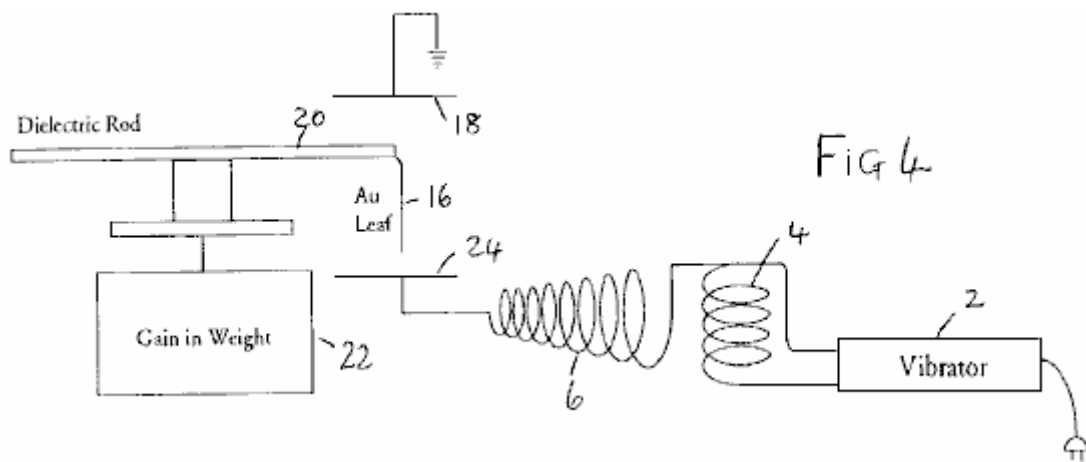
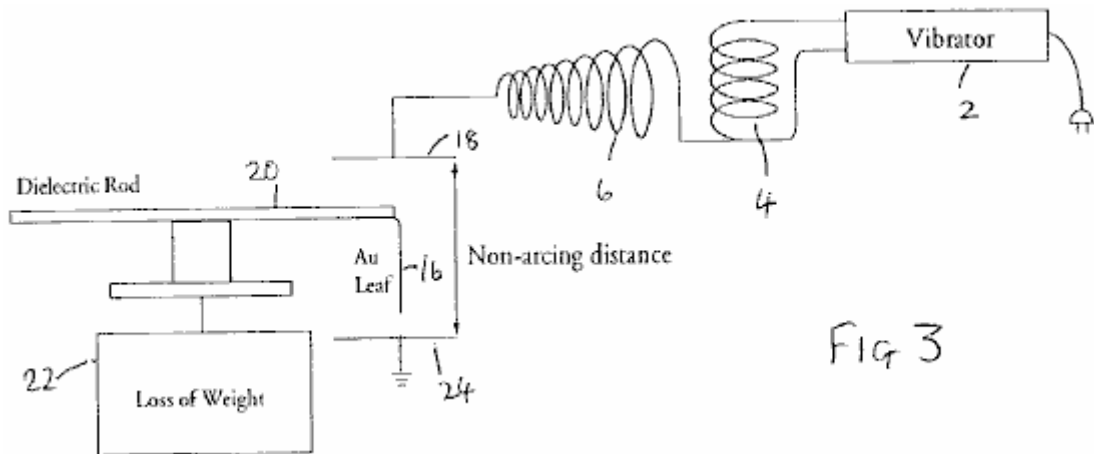

Fig.3 to Fig.6 show alternative electrometer configurations:



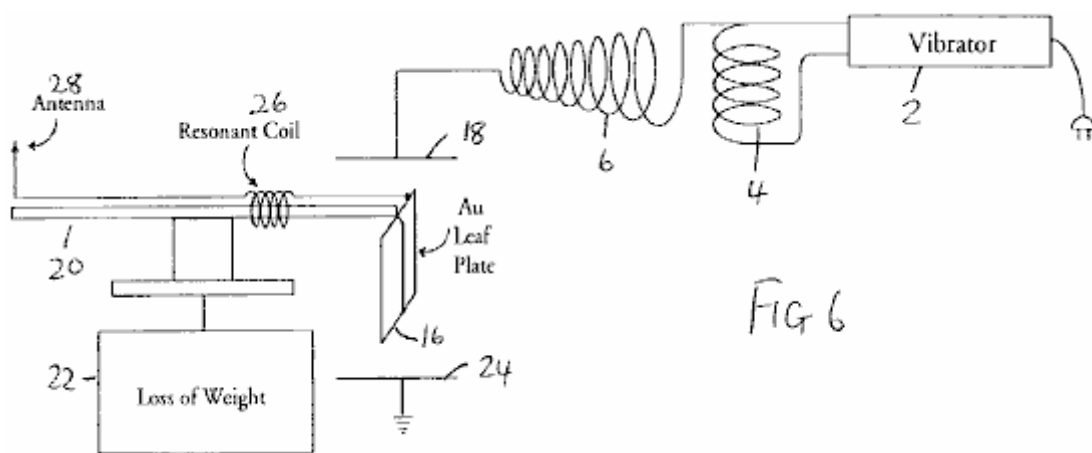
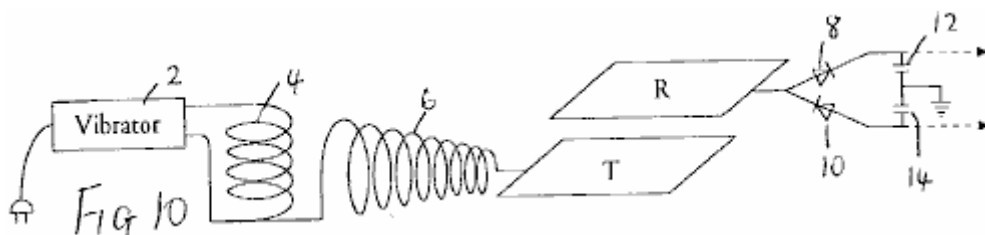
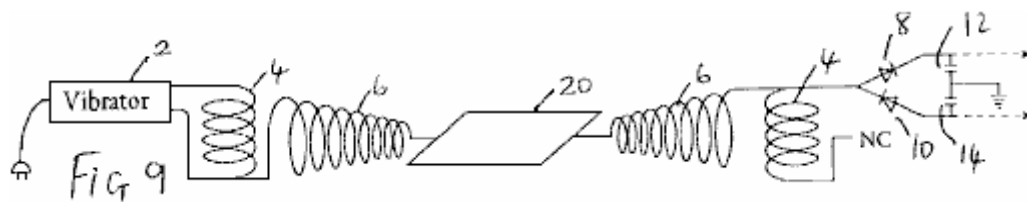
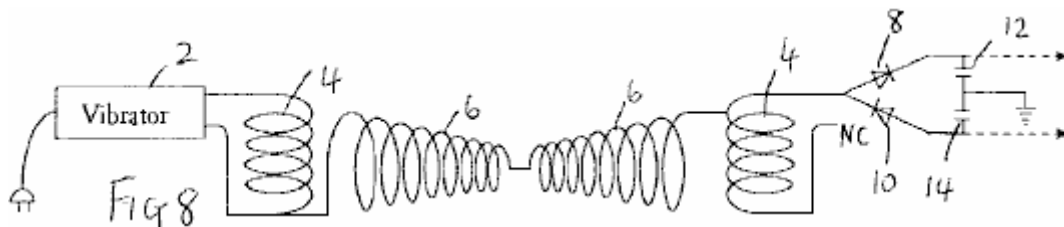
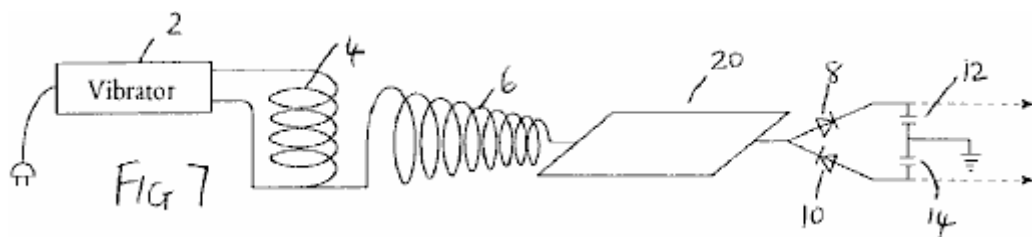

Fig.7 to Fig.11 show modifications of the circuit of Fig.1:



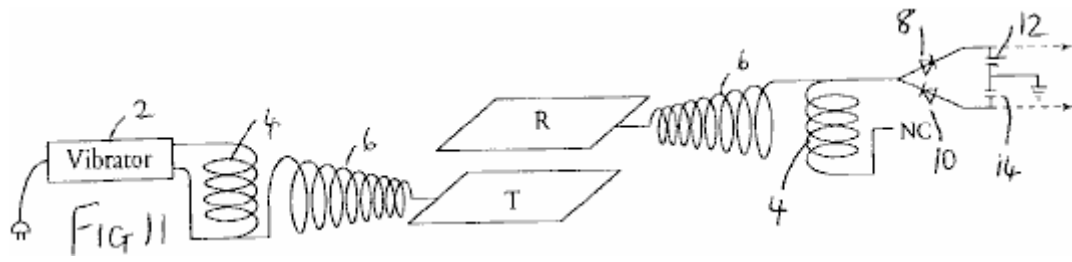

Fig.12 shows apparatus for investigating aspects of the experimental results obtained with the foregoing devices;

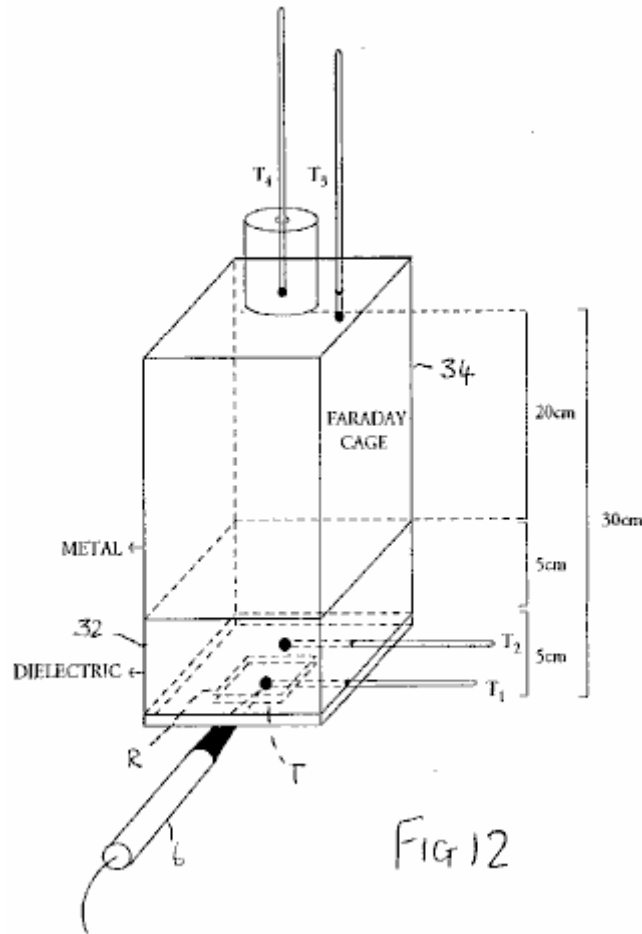

Fig 12

Fig.13 is a graph illustrating results obtained from the apparatus of Fig.12:

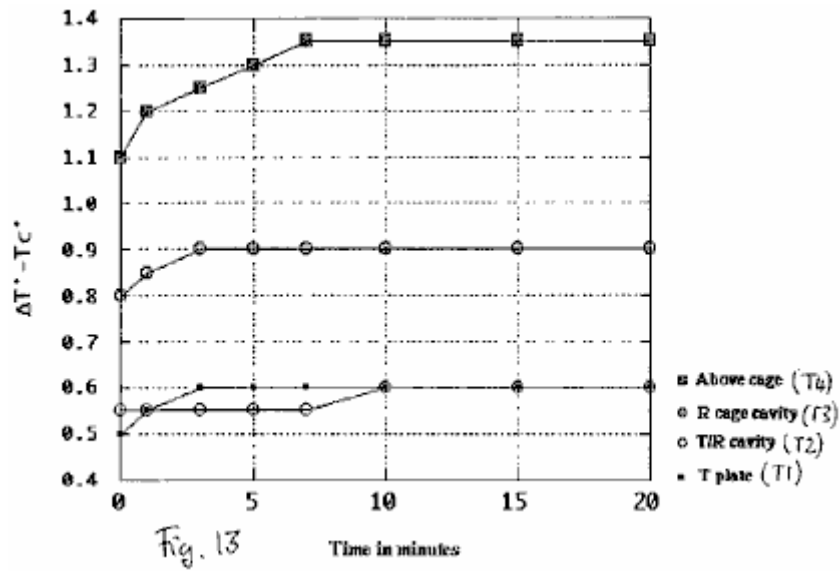
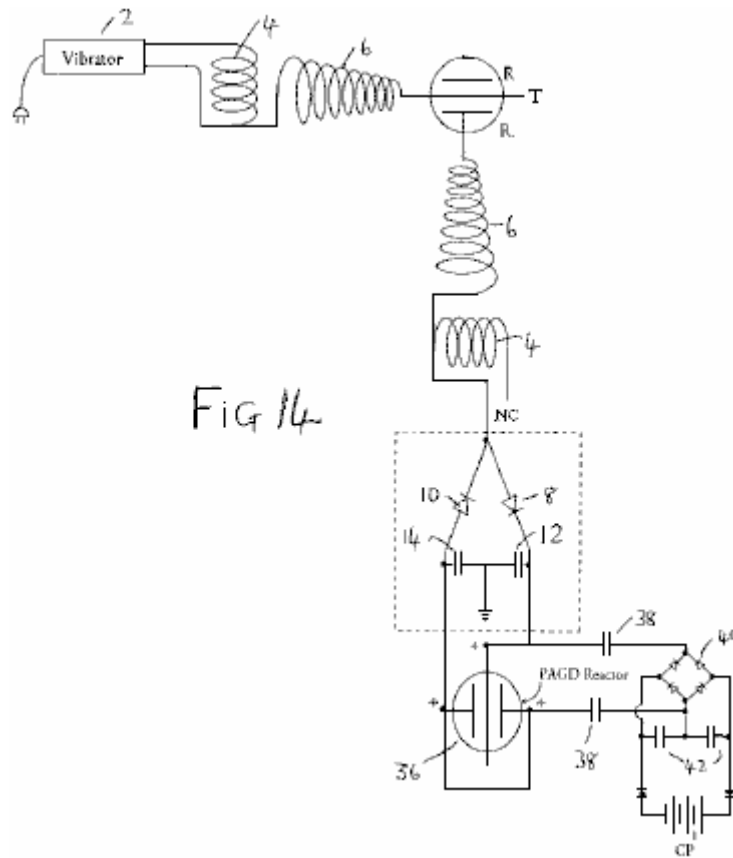

Fig.14 to Fig.17 show schematic diagrams of embodiments of energy conversion devices:



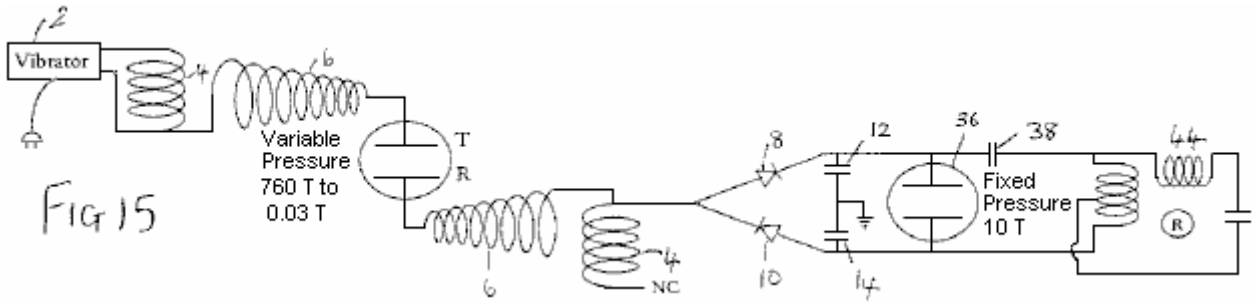

Fig 15

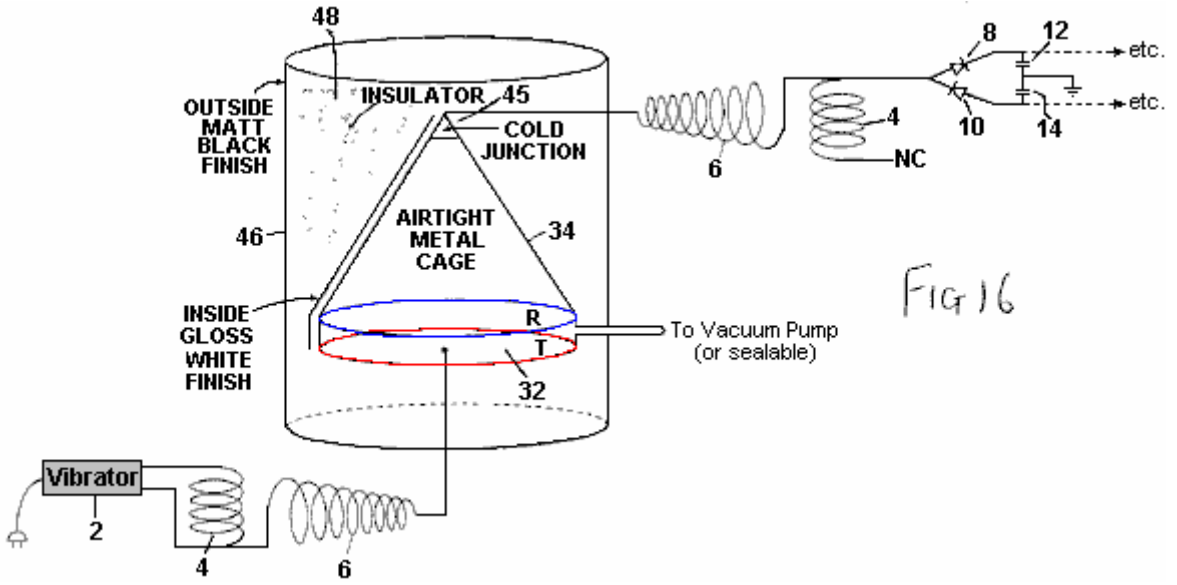

Fig 16

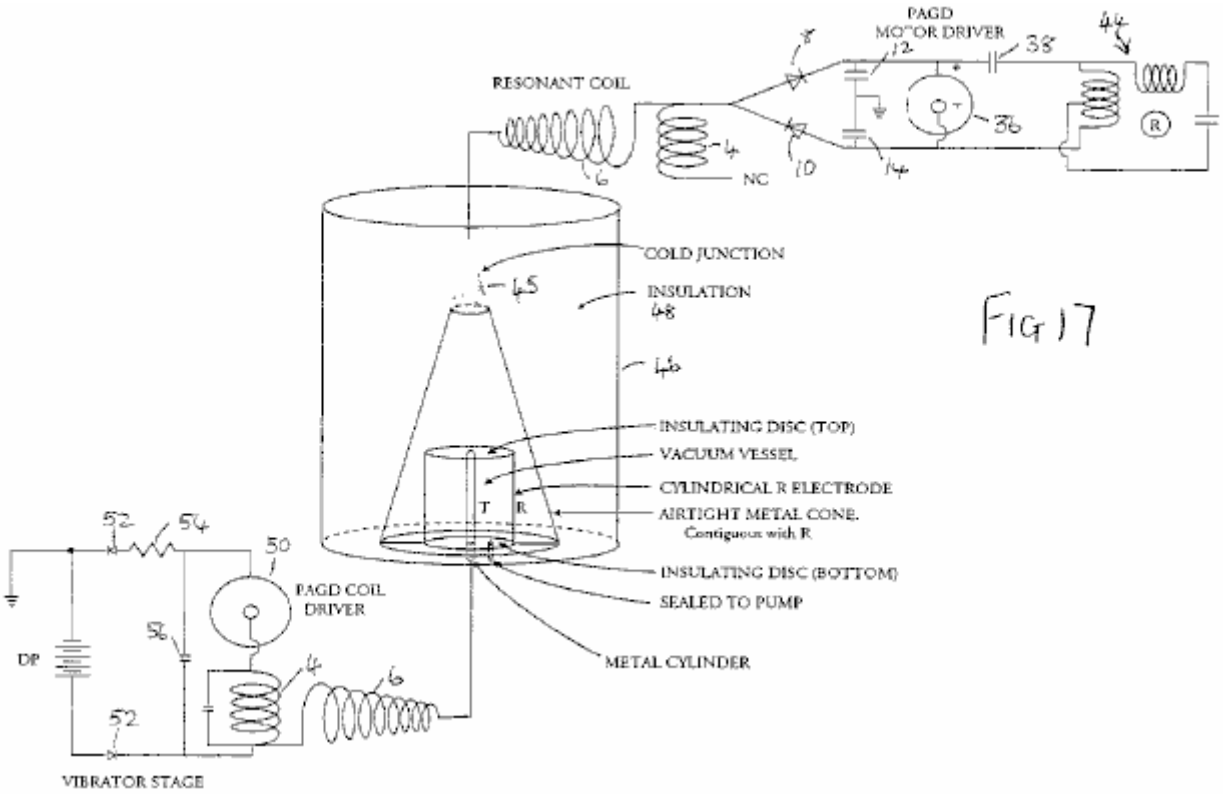

Fig 17

Fig.18 is a diagrammatic cross-section of an inertially dampened drag cup motor:

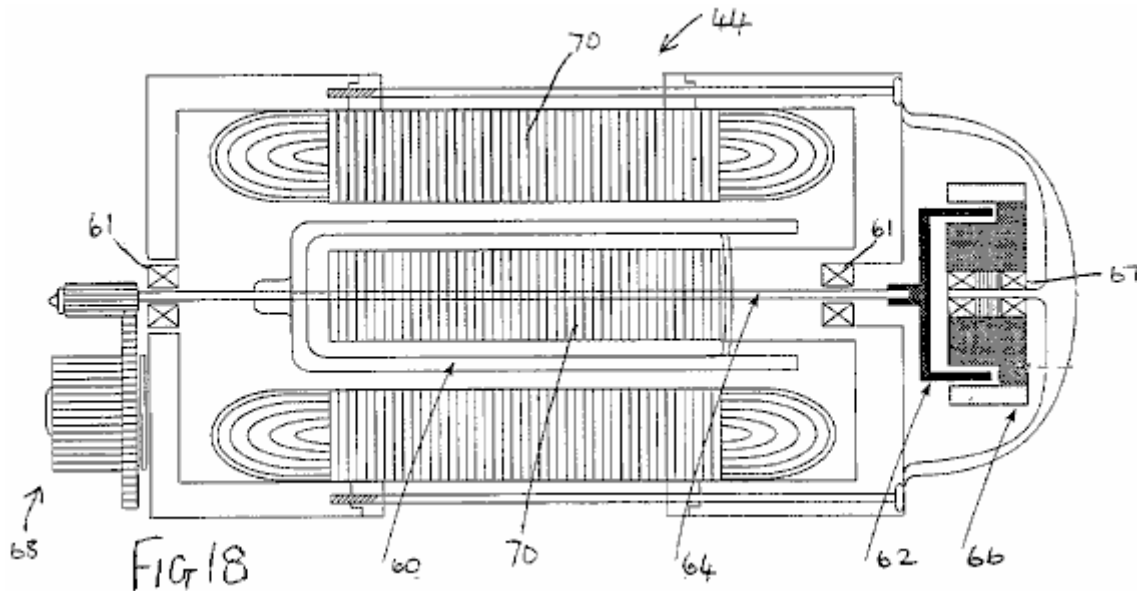
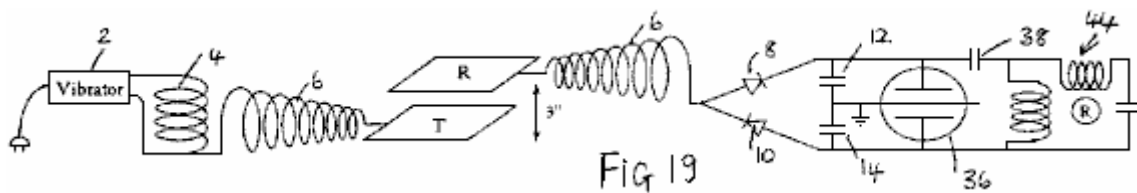

Fig.19 is a schematic diagram of a further embodiment of an energy conversion device incorporating such a motor:



DESCRIPTION OF THE PREFERRED EMBODIMENTS

Based upon observations of weight loss in metallic matter as induced by exposure to high frequency alternating electric fields, we developed an experimental method to optimise this-weight loss, and from this a device that treats the forces causing weight loss as manifestations of intrinsic potential energy ΔU (or true "latent heat") of the molecules of matter, and converts both "true latent heat" energy present in the neighbourhood of a receiver, and "sensible" heat induced within that receiver, into electric energy which can be used to drive a motor, flywheel or charge batteries.

It is commonly believed that the output of the Tesla coil is ionising electromagnetic radiation. We have demonstrated that it is not, i.e. that it is neither electromagnetic radiation, nor ionising electromagnetic radiation. The output of an air-cored, sequentially-wound secondary, consists exclusively of electric energy: upon contact with the coil, a mass-bound AC current can be extracted at the resonant frequency, whilst across a non-sparking gap, mass-free AC-like electric wave radiation having the characteristics of longitudinal waves, can be intercepted anywhere in adjacent space. Accordingly, the radiation output from such coils is different to electromagnetic radiation.

The basic demonstration that the output of a Tesla coil does not consist of ionising radiation, is that it does not accelerate the spontaneous discharge rate of electroscopes, whether positively or negatively charged. In fact, in its immediate periphery, the coil only accelerates the spontaneous discharge rate of the negatively charged electroscope (i.e. the charge leakage rate), whereas it arrests the discharge of the positively charged electroscope (i.e. the charge seepage rate falls to zero). But this dual effect is not due to any emission of positive ions from the secondary, even if it can positively charge a discharged electroscope brought to its proximity. This charging effect is in fact an artifact, in that metals but not dielectrics are ready to lose their conduction and outer valence band electrons when exposed to the mass-free electric radiation of the coil.

This is simply demonstrated by the apparatus of Fig.1, in which the outer terminal of the secondary winding 6 of a Tesla coil having a primary winding 4 driven by a vibrator 2 is connected to the input of a full-wave voltage wave divider formed by diodes 8 and 10 and reservoir capacitors 12 and 14 (the same reference numerals are used for similar parts in subsequent diagrams). If the rectifiers employed are non-doped, then the coil appears to only charge the divider at the positive capacitance 10, but if doped rectifiers are employed, the coil will be observed to charge both capacitances equally. Whereas positive ionises can charge either doped or un-doped dividers

positively, no positive ionise can charge a doped divider negatively, clearly demonstrating that the Tesla coil does not emit positive ions.

The basic demonstration that the output of a Tesla coil is not non-ionising electromagnetic radiation of high frequency, such as optical radiation, or of lower frequency, such as thermal photons, is also a simple one. Placement of a sensitive wide spectrum photoelectric cell (capable of detecting radiation to the limits of vacuum UV), wired in the traditional closed circuit manner from a battery supply, at any distance short of sparking from the outer terminal of the coil will show in the dark that the light output from the coil is negligible. This rules out optical radiation at high frequency. The demonstration that the sensible heat output from the Tesla coil is also negligible will be addressed below.

Our theory proposed the existence of physical processes whereby mass-free electric radiation can be converted into electromagnetic radiation. Such a process is at work whenever mass-free electric wave radiation interacts with electrons, such as those that remain in the valence bands of atoms. This mass-free electric energy interacts with charge carriers, such as electrons, to confer on them an electrokinetic energy which they shed in the form of light whenever that electrokinetic energy is dissociated from those carriers (e.g. by deceleration, collision or friction processes). Such a process is at work to a negligible extent in the coil itself and its usual terminal capacitance, hence the faint glow that can be seen to issue from it, but it can also be greatly amplified in the form of a corona discharge by connecting a large area plate to the output of the secondary, as Tesla himself did in his own experiments, and thus by increasing the capacitance of the coil system.

Now, what is interesting in this process is that, in the absence of virtually any I^2R losses at the plate, and if the plate thus introduced is bent at the edges so that it has no pointed edges, or if it is in the form of a bowl, or in any other manner that precludes sparking at edges and specially corners, and thus enhances the corona discharge, any electroscope, whether negatively or positively charged, now brought close to the plate will show a tendency to arrest its spontaneous discharge rate. One might say that this is simply the result obtained in a Faraday cage which disperses charge on its outside and electrically insulates its interior, and indeed if an electroscope is placed inside a Faraday cage no amount of Tesla radiation on the outside of that cage, save direct sparking, adversely affects the leakage or seepage rate of the electroscope. In fact, since the effect of such a cage can be shown to be that of, by itself, inducing arrest of either spontaneous electroscopic discharge, this effect simply remains or is magnified when the cage is bathed by Tesla radiation. However, a cage constitutes an electrically isolated environment, whereas a plate with or without curved or bent edges does not. Furthermore, the change observed in the properties of the output radiation from a Tesla coil when certain metal plates or surfaces are directly connected to the outer terminal of the secondary, takes place whilst the capacitance of the coil is increased by the connected plate, and thus the plate is an electrically active element of the circuit - and hence the opposite of an electrically isolated element.

For a long time, we believed that the anomalous cathode reaction forces observed in autoelectronic discharges (atmospheric sparks, autogenous PAGD (pulsed abnormal glow discharge) and vacuum arc discharges) were exclusive to an autoelectronic emission mechanism prompted by a direct potential between discharging electrodes. Sparking driven by AC potentials could sustain the same forces, but their mutual cancellation over time would not deploy a net force. In this sense, when a large gold leaf connected directly to the ground (via a water pipe or any other suitable connection) or to another large area plate suspended at some height above the ground, is vertically placed at a sparking distance above the surface of another plate connected to the secondary of a Tesla coil, one would not expect the AC spark to sustain any net force across the gap between the gold leaf and the plate. In terms of cathode reaction forces, one would expect their cancellation to be simply brought about by the high frequency of the current alternation in the coil, as both leaf and plate would alternate between being the emitting cathode or the receiving anode. However, this is not what is observed - instead, the gold leaf **16** lifts away from the plate **18** (Fig.2). If instead, the suspended gold leaf is connected to the coil terminal, and the bottom plate is connected to the ground in the same manner as described above, this also yields the same result.

Even more curious is the finding that this anomalous reaction force deployed by an alternate current of mass-bound charges in the arc, remains present when the sparking is prevented and instead the corona effect is enhanced (by employing a large plate connected to the outer pole of the secondary, and by employing a distance at which sparking ceases), as if the lift itself were the property of the corona underlying the spark channels and not the property per se of the autoelectronic emission mechanism.

By mounting the suspended leaf **16** (41 mg of hammered 99.9996% pure gold) directly at the end of a long dielectric rod **20** balanced at the centre and placed on a light stand over an electronic balance **22**, we sought to determine the observed lift of the leaf as weight lost. Surprisingly, and despite the most apparent lifting motion of the leaf, the balance registered a substantial weight gain, indicating the addition of 1 to 5 mg weight (with the same 14W input to the vibrator stage), independently of whether the leaf was connected to the terminal of the coil or instead to the earth ground via a water pipe. This suggested to us that, whether formed as a DC or AC spark channel, or whether in the form of a corona discharge, the electric gap develops an expansion force (exactly

opposite to a Casimir force) on both electrodes, independently of their polarity, which force is responsible for the observed repulsion. Yet, this expansion goes hand in hand with an increase in their weight such that some other process is at work in that electric gap.

To examine this problem further, we assembled a different experiment where the gold leaf **16** was suspended between two large metal plates **18** and **24** placed 20 cm apart, and the leaf was not electrically connected to them or to any other circuit, while attached to the dielectric rod employed to suspend it over the electronic balance. Given that the leaf is suitably and equally spaced from both plates, there is no arcing between it and either plate. The obvious expectation is that, since the electric field bathing the leaf alternates at high frequency (measured in hundreds of kilohertz), and the corona from both electrodes should equalise and balance any electric wind, no lift should be observed. In fact, no lift is apparent, but a most curious observation is made: depending upon which orientation is employed for the plates, the gold leaf either gains or loses 4-6% of its weight. This gain or loss is registered for as long as the coil is on. If the top plate is grounded and the bottom one connected to the different terminal of the secondary, a gain in weight is observed (**Fig.3**). If the connections are reversed, an equal weight loss is registered (**Fig.4**).

Furthermore, in this last instance, if the grounded plate **24** is entirely removed (**Fig.5**), and only the top plate remains connected to the outer terminal of the secondary, the observed loss of weight continues to occur such that in effect, this reaction can be obtained with unipolar electric fields of high frequency, and it provides a unidirectional force which, once exerted upon metallic objects bathed by its field, can be made to oppose or augment gravity.

Now, these effects can be greatly magnified, in the order of 10-fold, if the same gold leaf is made part of a simple series floating electric circuit where the leaf functions as a large area plate, and is wired in series with a coil **26** which, for best results, should be wound so as to be of a length resonant with the secondary of the Tesla-type coil employed; and this coil is connected in turn to a point antenna **28** upwardly oriented (**Fig.6**). The entire floating circuit is mounted on the rod **20** and this in turn, is mounted over the sensitive balance. If both plates are kept as in **Fig.3** and **Fig.4**, the observed weight loss and weight gain both vary between 30% and 95% of the total weight of the leaf. Again, the gain or loss of weight is registered for as long as the coil is on.

These anomalous findings suggested that, whatever is the nature of the energy responsible for the force observed in that high frequency alternating current gap, any metallic object placed in that gap will experience a force repelling it from the electric ground. This force will be maximised if the gap frequency is tuned to the elementary or molecular structure of the metallic object. If the electric ground is placed opposite the actual plane of the earth ground, that force will act in the direction of gravity. If, instead, the electric ground and the earth ground are made to coincide on the same plane, that force will act opposite the direction of gravity, i.e. will repel the metallic object from the ground.

No such weight alteration was observed with solid dielectrics, for instance with polyethylene and other thermoplastic sheets.

These facts rule out the possibility of a hidden electrostatic attraction force, acting between the plate connected to the different terminal of the secondary and the gold leaf. Firstly, such an attraction would be able to lift the gold leaf entirely, as is easily observed with the unipole of any electrostatic generator operating with a few milliwatts output with either negative or positive polarity; secondly, the same attraction, if it existed and were the product of an electric force, would surely be manifested independently from whether the experimental leaf was metallic or a dielectric (as again is observed with electrostatic generators).

The results suggest therefore, that whenever a large plate is connected to a Tesla-type coil, it induces in surrounding matter that is not part of its own circuit, a directional thrust which is oriented in a direction which is opposite to the electric ground and, if the electrical ground is on the same side as the surface of the Earth, then a thrust is produced which opposes gravity.

When this thrust is made to oppose gravity, we believe that its effect upon the gold leaf can be compared to the lifting power imparted to the water molecule when it transits from the liquid to the vapour state and which is associated with the increase in internal (or intrinsic) potential "thermal" energy ΔU (See Halliday D & Resnick R (1978) "Physics", Vol. 1, section 22-8, p. 489). The "specific latent heat" of water ($m \cdot L$) contains indeed both an expression for the sensible radiant thermal work involving volume and pressure relations:

$W = P(V_V - V_L)$ where P = a pressure of 1 atmosphere, and V_V and V_L are the molar volumes in the vapour and liquid phases respectively, and an expression for a quantity of "latent" energy (ΔU) which is associated with the molecule in the more rarefied state. Hence, the relation for the latter with respect to water vapour is: $\Delta U = mL - P(V_V - V_L)$

We propose that likewise, if a very small portion of the energy of the mass-free electric waves is indirectly transformed by mass-bound charge carriers on that plate into blackbody photons (once those charge carriers shed their electrokinetic energy), the greater portion of those waves are directly transformed in the space adjacent to that plate into the latent energy equivalent to ΔU for the atoms of the surrounding air, and so on, until this process itself is also occurring for the atoms of that gold leaf, thus inducing their non-electrical weight loss and suggesting the existence of a non-thermal "antigravitokinetic" energy term previously unknown to mankind other than as "latent heat" or "internal potential energy".

From this viewpoint, the energy released by any Tesla-type coil to its surroundings, would be tantamount to a radiative injection of "internal potential energy" which would confer on local gas molecules a weight cancellation (a cancellation of gravitational mass occurring in the absence of any cancellation of inertial mass - a process which the inventors theorise is explained by the neutralisation of elementary gravitons), and the same process would be equally at work for metallic solids but not dielectric solids.

Gold vapour also deploys a substantial intrinsic potential energy. With an enthalpy of vaporisation on the order of $H_V = 324 \text{ kJ mol}^{-1}$, the molar volumetric work performed by gold vapour at atmospheric pressure at the temperature of vaporisation T_V (2,856°C., i.e. 3,129 degrees Kelvin) is:

$W = P \Delta V_{V-L} = 23.58 \text{ kJ mol}^{-1}$ where $\Delta V_{V-L} = 0.2327 \text{ m}^3$. The intrinsic potential energy of gold vapour is then given by:

$\Delta U = H_V - W = 300.4 \text{ kJ mol}^{-1}$ i.e. 12.74 times greater than the volumetric work performed during the phase transition.

It is our contention that this intrinsic potential energy, associated with molecules as their "latent heat", has fine structure that in turn is altered if this energy is released from these molecules and fails to gain a "sensible" thermal form. What is suggested is that the fine structure of "latent heat" is not electromagnetic and obeys instead the molecular function:

$\Delta U / N_A = \lambda_{n2}^2 c f_{n2}$ where N_A is Avogadro's number, the wavelength denoted as λ_{n2} is the wavelength-equivalent of the mass of the molecule to which the "latent heat" is associated, obtained by a conversion method proposed in these inventors' theory, and the frequency term f is a non-electromagnetic frequency term, specifically in this case a gravitational frequency function.

Employing the conversion of Joules into $\text{m}^3 \text{ sec}^{-2}$ proposed by these inventors as being exactly:

$1 \text{ J} = 10 N_A \text{ m}^3 \text{ sec}^{-2}$, and putting the wavelength λ_{n2} down as the wavelength-equivalent of the mass of the gold atom, λ_{Au} , at 1.9698 m, that frequency term f_{n2} can be obtained as being equal to $2.6 \times 10^{-3} \text{ sec}^{-1}$.

According to the present inventors' theory, the wave function c constitutive of the fine structure of "latent heat" associated with molecules of matter, carries the same wavelength λ_{Au} and its frequency is given in the usual manner by $c/\lambda_{Au} = 1.52 \times 10^3 \text{ sec}^{-1}$. The resultant frequency for the non-Planckian unit quantum of "latent energy" associated with each gold atom at the vaporisation temperature is then obtained by the geometric mean of the two synchronous frequency terms: $[(c/\lambda_{Au}) f_{n2}]^{0.5} = 624 \text{ Hz}$. However, this is the signature of that intrinsic potential energy when associated with that gold atom at its vaporisation temperature. It is not the signature of the energy quantum itself if it is released from that molecule, nor prior to being absorbed (i.e. in transit), at that same temperature.

The fine structure of the same non-Planckian "latent" energy quantum varies to encompass different determinations of the constituent wavelength and frequency functions. The basic relation for the determination of the wavelength of a "latent thermal" energy quantum not associated with matter, but corresponding to one that is, is:

$$\lambda_{n1} = [(\Delta U / N_A) / c]^{0.666} \text{ meters}^{-0.333} \text{ seconds}^{0.666}$$

which gives 0.046478 m for the unbound equivalent of the "latent heat" unit quantum of vaporisation associated with the gold atom at a pressure of one atmosphere. The fine structure of the free quantum is still parallel, as given by:

$$\Delta U / N_A = \lambda_{n1}^2 c f_{n1}$$

but now notice how the frequency terms have changed value, with the f_{n1} function having the value 4.65 sec^{-1} and c/λ_{n1} yielding $6.48 \times 10^9 \text{ sec}^{-1}$. The geometric mean of the superimposition of the two frequencies is then:

$$[(c/\lambda_{n1}^2)f_{n1}]^{0.5} = 173.7 \text{ KHz}$$

We contend that it is at this frequency that the atoms of gold vapour absorb "latent heat".

However, this is just the overall scenario of what happens at the temperature of vaporisation of gold. But at room temperature (e.g. 293 degrees Kelvin), and with respect to processes where there is no sublimation of the atoms of that gold leaf under way (and indeed, once the coil is turned off, the leaf returns to its normal weight), one must infer to a different phase of matter what portion of "latent heat" energy, if any, do the atoms of gold hold in the solid phase lattice. Assuming the same proportionality between the "sensible" and "latent" thermal energy terms for atoms of gold at room temperature, where the unit thermal energy is $N_A kT = 2.436 \text{ kJ mol}^{-1}$, we speculate that the gold atom could absorb up to 12.74 times the value of this "sensible" thermal energy, and thus hold $N_A kT = 31.053 \text{ kJ}$ more energy in its own micro-atmosphere.

If this speculation is correct, and employing the above novel methodology, then the mean geometric frequency of the maximal "latent heat" energy quantum of a gold atom at room temperature would be 538 KHz (versus 174 KHz at the vaporisation temperature), and once absorbed its mean frequency mode would reduce to 201.5 Hz (versus 630 Hz once the atom has vaporised).

To test this hypothesis, we employed two different Tesla-type coils having output frequencies of 200 KHz and 394 KHz. The circuit tested was that shown in **Fig.6**, and both coils were operated at 50 KV outputs. Whereas the former coil, closer to the 174 KHz marker, could only systematically produce 10mg to 11 mg of weight cancellation in the gold leaf of the floating circuit, the second coil, closer to the speculated 538 KHz marker, could produce 15mg to 35 mg of weight cancellation in the same gold leaf. The empirical results appear therefore to suggest that our speculation may well be a valid one.

The above-mentioned full wave divider (see **Fig.1**) can be easily coupled to our autogenous Pulsed Abnormal Glow Discharge technology as described in our U.S. Pat. No. 5,416,391 to form an alternative source of direct current, ultimately powered by Tesla waves, and such a drive can equally be applied to any other vacuum device that can sustain endogenous oscillatory discharges, whether in the PAGD regime or any other pulsatory regime. For the purposes of experimental and visual determination of power outputs from the divider in question, we have utilised either 2 Torr vacuum tubes operating in the high-current PAGD regime, or 20-100 Torr spark tubes requiring high voltages (2 to 10 KV) for their spark breakdown. As taught in the above US Patent, the output from the full wave voltage divider can be assessed by the energy spent in driving the tube and the motor, whose rotary speed is proportional, within the limits chosen, to the power input.

Two separate sets of experiments presented in Table 1 below, showed that direct connection of the wave divider to the outer terminal of the coil (set constantly at 6 clicks on the vibrator stage in **Fig.1**) or to the same terminal but across a large (2 or 3 square feet) plate **30** that increased the capacitance of the secondary (**Fig.7**), presented the same power output in either case (the effect of the plate is to lower the voltage of the output proportional to the increase in current). A substantial increase in power output through the divider is observed only when an identically wound Tesla coil is connected in reverse (**Fig.8**) with the non-common end of its winding **4** not connected, in order to obtain a condition of resonance, and this observed increase is further augmented by now interposing either of the metal plates **18**, **24** between the two **chirally** connected and identical coils (**Fig.9**). The increase in plate area appears to have the effect of increasing the output for as long as the plate is isolated between the two chiral image coils. Throughout these experiments, the input power to the vibrator was fixed at 14W (60 Hz AC). [Note: 'Chirality', or 'handedness', is a property of objects which are not symmetrical. Chiral objects have a unique three-dimensional shape and as a result a chiral object and its mirror image are not completely identical - PJK].

TABLE 1

Status	Pulse rate (PPS)	Motor rotation (RPM), M \pm SEM
<u>Expt A</u>		
Tesla coil (TC) to divider	2.6	582.5 \pm 3.9 (n = 4)
TC to inverted TC, to divider	4.4	621 7.6 (n = 4)
TC to 2 ft ² plate, to inverted TC, to divider	5	775.25 \pm 23.6 (n = 4)
<u>Expt B</u>		
Tesla coil (TC) to divider	2.2	613 \pm 5.6 (n = 12)
TC to 3 ft ² plate, to divider	2.3	605 \pm 2.6 (n = 12)
TC to inverted TC, to divider	2.3	722 \pm 5.7 (n = 12)
TC to 3 ft ² plate, to inverted TC, to divider	4.2	877.6 \pm 6.5 (n = 12)

In our loss of weight experiments described above, we noted that the phenomenon of weight loss by a metallic body placed in proximity of the coil output continued to be observed when only the plate connected to the distal pole of the secondary was retained. The leaf, although not part of the circuit of the secondary, could however be seen as part of a circuit for the capture of ambient radiant energy, specifically that generated by the coil and, as well, that also possibly picked up, in the process, from other ambient sources. To determine whether the last consideration is a possibility at all, or whether the energy picked up by an analogue of our metallic body or gold leaf in the experiments described above, is entirely a by-product of the energy transmitted by the plate connected to the outer pole of the secondary, we next determined what would happen if the pick-up for the full-wave divider were placed, not at the output from the secondary coil, but from an, in all respects identical, plate (the Receiver plate **R**, as opposed to the Transmitter plate **T**) placed a distance away from, and above, the first one. In other words, the gold leaf is replaced by a receiver plate, and this carries an attached test circuit identical to the test circuit employed to directly assess the coil output.

TABLE 2

Status	T R distance	Pulse rate (PPS)	Motor rotation (RPM), M \pm SEM
<u>2 ft² plates</u>			
R plate to inverted TC, to divider	3"	6.7	882 \pm 17.5 (n = 4)
	4"	8	906 \pm 12.1 (n = 4)
	6"	10	936 \pm 46.1 (n = 9)
<u>3 ft² plates</u>			
TC to T plate, to divider	0	2.3	605 \pm 2.6 (n = 12)
R plate to divider	6"	3.3	890.1 \pm 3.8 (n = 12)
R plate to inverted TC, to divider	6"	5.1	1009.2 \pm 4 (n = 12)
R plate to divider	8"	4.0	783.1 \pm 11.3 (n = 12)
R plate to inverted TC, to divider	8"	5.1	1005.7 \pm 6 (n = 12)

As shown in Table 2 above, the results of the experiment show that there is no loss of energy picked up at the **R** plate (**Fig.10**) when compared to the most favourable situation involving the plate **30** (**Fig.9**) interposed between the chirally connected coils. This observation is however not always the case. For best results one should employ iron, gold or silver plates placed parallel to the horizon, with the **T** plate underneath the **R** plate. In fact, if one employs instead aluminium plates and suspends these vertically, one can consistently register a loss of output at the divider when changing the divider input from the **T** to the **R** plates.

If however the plate **R** is connected in turn to a second identical coil, also wired in reverse, and this second coil in turn serves as input to the full-wave divider (**Fig.11**), then a most curious occurrence takes place - the power output increases considerably (see Table 2), as if the divider circuit had undergone an energy injection not present at the source. Note that the circuits are in fact resonant, but the energy injection contributing nearly 60-66% (for both plate areas in the previous experiment) of the input that we refer to, is not caused by inductive resonance, since the effect of resonance can be ascribed to the set-up described in **Fig.9**. The distance between the plates, as well as their orientation with respect to the local horizon system of the observer also appear to matter, best results being achieved at optimal distances (e.g. for 2 square feet plates the best gap, at 43% RH and room temperature, was at least 6 inches).

We tested the possibility that environmental heat produced by operation of the coil might be the source of the injected energy, the plate of the second system acting possibly as collector for the heat present in the gap. As it turned out, experiments showed repeatedly that in the gap between the **T** and **R** plates there was no significant thermal radiation propagating between one and the other. The more illustrative experiments are those in which we identified where the sensible thermal energy appears, and which involved coupling two cavities: the Transmitter-Receiver gap between plates **T** and **R**, and a Faraday cage enclosure **34** (see **Fig.12**). The first cavity appears to be much like that of a capacitor: the two identical parallel plates are surrounded by a thick dielectric insulator **32**, and a thermometer **T2** is inserted half-way through it. A thermometer **T1** is also fixed to the **T** plate, to measure its temperature. The second cavity is a simple insulated metal cage with a thermometer **T3** inserted 2 cm into its top. Some 2-4 cm above the top of the cage there is placed a fourth thermometer **T4**, inside an insulated cylinder.

If the Tesla Coil is a source of thermal energy (e.g. IR radiation, microwaves, etc.) we would expect the **T** plate to be the hottest element from which, by radiation, thermal energy would reach the middle of the first cavity making the next thermometer **T2** second hottest, and that the third thermometer **T3** inside the second cavity, even if it might initially be slightly warmer than the other two, would, over time, become comparatively cooler than either one of the other two thermometers, despite the fact that the rising heat would still be seen to warm it up over time. One would expect a similar outcome for the fourth thermometer **T4**, above the cage. As shown by **Fig.13**, where only the temperature differences ($\Delta T^0 - T_C^0$) between the experimental thermometers and the control thermometer reading the air temperature T_C^0 of the laboratory are shown, the surface of the **T** plate warms up by 0.1°C . at 3 minutes after initiation of the run (closed squares), whereas in the space of the T/R gap a diminutive warming, by 0.05°C ., is registered after 10 minutes (open circles). Conversely, the temperature inside the cage, at the top (shaded circles) rises by 0.1°C . also by the third minute, and the temperature above the cage itself (shaded squares) rises by a much greater difference of 0.35°C ., which remains stable after the eighth minute.

These results show that it is not sensible heat that radiates from the **T** plate. Instead, some other form of radiation traverses these cavities to generate sensible heat at their metallic boundaries, such that more heat is generated above the **R** plate (inside the cage) and again above the third plate, i.e. above the top of the cage, than is generated in the T/R gap, i.e. near the **T** plate. This clearly shows that the Tesla coil is not a significant source of thermal radiation, and that sensible heat can be detected inside and on top of the Faraday cage only as a further transformation of the radiant energy transmitted across the T/R cavity.

The same experiment also illustrates that, whatever is the nature of the additional environmental energy being injected at the surface of **R** plate (as shown by Table 2 results above), it is most likely not thermal radiation, at least not energy in the form of sensible heat. And whatever is the nature of this ambient radiant energy being mobilised by the electric radiant energy transmitted from the **T** plate, it can produce significant heat inside an enclosure adjacent to plate **R**.

Since we also know experimentally, that this observation of an ambient energy injection at the **R** plate or **R** cage depends upon relative humidity, being most easily observable when the latter is low (<50% Relative Humidity), and being virtually impossible to observe when air is saturated with water vapour, we can infer that water vapour is a good absorber of the electric mass-free radiant energy emitted from the **T** plate. This strongly suggests that this absorption process is tantamount to increasing the potential intrinsic energy ΔU of the water vapour molecules adjacent to the **T** plate. In the absence of significant quantities of water vapour, when the atmosphere is dry, one may speculate that this absorption process is replaced by what one presumes is a parallel process involving the various gaseous molecules of air. However, either because the air molecules involve molecular species that readily give off this potential energy, as one might speculate is the case with molecular oxygen, hydrogen and nitrogen, or because the air molecules absorb far less "latent" energy (as appears to be the case with inert gases), and therefore there is more of it in the molecularly unbound state (as we explicitly propose as a possibility) and thus available for absorption by the appropriately tuned receiver, the increased ΔU of air molecules conferred by the absorption of the mass-free electric radiation in the T/R gap is transferred to the **R** conductor together with the latent energy which those molecules already possessed before entering that gap. Hence the

energy injection and its dependency upon the partial pressure of water vapour, which absconds instead with this "latent" energy and succeeds in withholding it from transmission to the **R** plate.

If the T/R gap can mobilise ambient energy which is neither electromagnetic nor thermal in nature, but which "latent" energy becomes injected into the divider circuit in electric form, the heat (i.e. sensible thermal energy) produced inside and on top of the cage, can also be mobilised electrically as input into the divider circuit. The obvious place to look for the positioning of the cool junction which could convert sensible heat into electrokinetic energy of mass-bound charges is at the top of the cage, where it is warmest (See top curve of **Fig.13** in shaded squares). This is clearly observed from the results shown in Table 3 below, where the initial temperature difference between the top of the box and the **T** plate surface was 0.5⁰C., and the top of the box temperature rose by 0.2⁰C. after 2.5 minutes when the divider was connected at the junction, versus 0.35⁰C. when it was not (and the transmitter coil was on).

TABLE 3

Status	TR distance inches	Pulse rate PPS	Motor rotation RPM, M ± SEM (n = 12)
<u>3 ft² plates</u>			
TC to T plate, to divider	NA	4.2	877.6 ± 6.5
R plate to inverted TC, to divider	6"	5.1	1009.2 ± 4
Top of naked R plate/ cage to divider	6"	5.4	1047.1 ± 5.7
Top of insulated R plate/cage exposed to sun, to divider	6"	6.1	1072.4 ± 8.7

For the run performed with the naked **R** cage, the temperature directly above the top of the cage was 24.3⁰C., at the outset, versus the control room temperature of 23.9⁰C. For the run performed with the insulated **R** cage exposed directly to the sun at midday, on a cool and clear August day, the temperature directly above the top of the cage was 33⁰C., versus the control air temperature of 18.4⁰C. The temperature of the cool junction at the top of the cage was 31.9⁰C. while the run was performed.

It is apparent from the data of Table 3, how a second injection of energy has occurred in the apparatus. If, within the T/R gap, the energy injected appears to be on the order of absorption of "latent heat", at the top of the cage cavity, at the cool junction, the injection is one of radiant "sensible" heat. Moreover, this secondary energy addition could be further enhanced by placing strong insulation around the whole apparatus or the cage itself, and further so, by exposing the whole apparatus to solar radiation.

We next turned our attention to the T/R gap cavity with the intention of determining whether atmospheric conditions or vacua yield the same or different results. We could not, of course, test the same large area plates as have been employed for the studies undertaken at atmospheric pressures. For the present purpose we employed instead large area electrodes (ca 0.2 ft²) made of high grade stainless steel or even aluminium. Preliminary results showed that these T/R gap tubes, when coupled to the divider circuit, yielded faster pulse rates in the secondary circuit when evacuated than at atmospheric pressure. The strength of the corona discharge also intensified, as it eventually became replaced by a normal glow discharge. For purposes of improved spatial capture of (1) the electric mass-free energy radiated from the **T** electrode and (2) the non-radiant latent thermal energy mobilised by it to be collected electrically at the **R** plate, an axial cylindrical **T** electrode was inserted inside a larger concentric cylinder or between two common plates of large surface area (e.g. >100 cm²) functioning as the **R** electrode(s), in a dielectric container suitable for evacuation (glass, polycarbonate), at a typical distance of at least 3 cm between electrodes, and the entire device was tested at different pressures.

The secondary circuit connected downstream from the full-wave divider was as shown in **Fig.14** (employing an autogenous pulsed abnormal glow discharge, or PAGD, converter circuit), with the PAGD reactor **36** set at 10 Torr (in light of the high-voltage input, which varied between 1,500V and 3,200V) and gave the results presented in Table 4 below. We should remark also that these pulses charged the charge pack **CP** through the coupling

capacitors **38**, bridge rectifier **40** and reservoir capacitors **42**, and blocking diodes **44**, as expected from the prior art represented by our patents related to PAGD devices.

TABLE 4

T/R tube Pressure (Torr)	Pulse rate (PPS)
760	0.376
0.025	0.513

The effect of the vacuum in the T/R gap tube seems to be dual. By transforming the corona discharge into a normal glow discharge, it increases the local production of photons (probably associated to the formation and discharge of metastable states in the plasma), and at the same time, increases the pulse rate in the output circuit and thus, in all probability, the energy injected in the T/R gap cavity. But this did not yet permit us to confirm whether or not it is "latent heat" energy of the plasma molecules which is being tapped at the receiver plate, even if it be plausible in principle that plasmas may effect more efficient transfer of "latent heat" to tuned receivers than atmospheric gases.

The vacuum dependency of the pulse rate of the PAGD reactor employed as example in the secondary circuit downstream from the divider is also rather well marked, with the fastest pulse rates being registered at 1 Torr for the sample run shown in Table 5 below.

TABLE 5

T/R tube Pressure (Torr)	Pulse rate (PPS)	PAGD Reactor Pressure (Torr)	Voltage (across divider)
0.025	0.115	90	4.5 kV
0.025	0.1553	75	3.5 kV
0.025	0.183	60	3.3 kV
0.025	0.291	30	
0.025	0.513	15	1.6 kV
0.025	0.602	10	1.4 kV
0.025	2.9	2	0.53 kV
0.025	4.1	1	0.45 kV

It is worth noting here that the illustrated polarity of the wiring of the PAGD reactor tube, as shown in **Fig.14**, is best for purposes of sustaining regular auto-electronic emission at high voltage. The reverse configuration, with the centre electrode negative and the plates positive favours instead heating of the cathode and a lapse into a normal glow discharge.

We tested a similar arrangement to that shown in **Fig.14** above, but with a PAGD motor circuit (see our U.S. Pat. No. 5,416,391). A split-phase motor **44** replaces the rectifier and charge pack, and the PAGD reactor is operated at the same pressure of 15 Torr, as shown in **Fig.15**. The T/R gap tube tested had a longer plate distance (2"), with one plate now functioning as Transmitter and the other as Receiver. Note also the different wiring of the PAGD reactor. The results, as shown below in Table 6, present pulse per second (PPS) and motor revolutions per minute (RPM) curve trends that appear to be analogous and parallel to the well known Paschen curves for breakdown voltage in vacuum - such that the T/R gap performs better either in the atmospheric corona discharge mode, or in the high vacuum normal glow discharge (NGD) mode, than in the low breakdown voltage range of the curve where the discharge forms a narrow channel and takes on the appearance of an "aurora" transitional region discharge (TRD).

TABLE 6

T/R tube Pressure (Torr)	Pulse rate (PPS)	Motor rotation (RPM), M \pm SEM (n = 17)	Discharge Type
760	2.8	751.2 \pm 7.1	Corona
100	2.1	611.5 \pm 5.1	TRD
20	2.4	701.9 \pm 4.6	TRD
0.006	2.8	748.4 \pm 9.3	NGD
0.003	3.0	819.4 \pm 6.3	NGD

These results suggest that plasmas with high lateral dispersion, i.e. formed over large electrode areas (e.g. corona and NGD plasmas) and thus devoid of pinch, are more likely to mobilise electrically, the intrinsic potential energy of the molecular charges than pinch plasmas appear to be able to do (e.g. TRD plasmas). Apparently also, the greater the vacuum drawn from the T/R gap cavity, the more efficient does the transfer of this intrinsic potential energy become, i.e. the mass-bound latent heat, to the electrokinetic energy of the charges circulating in the receiver circuit. At about 0.06 Torr, this transfer in vacuo is comparable to that observed under atmospheric conditions and thus for a much greater density of molecules.

We investigated whether it is possible to tap the latent heat energy of water molecules. It is possible that in the vapour phase they can effectively hold on to their latent energy - but could they give off some of it once closely packed in liquid phase? To test this hypothesis we immersed the T/R gap in a glass water tank. The motor employed for these tests was a high-speed 2-phase drag-cup motor (see **Fig.18** and associated description), wired in split-phase with two identical phase windings capacitatively balanced, and the galvanised iron plates each had an area of one square foot. The results are shown in Table 7 below, and clearly indicate that it is possible to tap - within the T/R cavity - the 'latent heat' of water in the liquid phase. As observed, immersion of the T/R cavity in water increased the motor output speed 22% (12,117 / 9,888) x 100). This corresponds to a 50% increase in power output, from 18W at 9,888 rpm to 27W at 12,117 rpm:

TABLE 7

	Pulse rate PPS	Motor rotation RPM M \pm SEM	T/R distance cm
Direct from TC	0.3	8076 \pm 89.3	NA
TC to T plate	0.5	9888 \pm 78.7	NA
R plate	2.75	12117 \pm 29.8	30
R plate	2.9	12203 \pm 55.9	60

Thus the use of ion-containing water or other ion-containing aqueous liquid in the cavity promotes long distance propagation and a greater injection of latent and thermal energies in the receiver circuit. Such a result is not achieved if the cavity is filled with deionised water.

The preceding results lead therefore to the design of a presently preferred apparatus, based on these findings, for the conversion of mass-free electric energy, "latent heat" energy and "sensible" heat energy into conventional electric energy, as shown in **Fig.16**, which integrates all of the separate findings and improvements. The winding **6** of the Tesla coil at the bottom is driven in the usual manner employing a vibrator stage **2** to pulse the primary coil **4**. The outer pole of the secondary **6** is then connected to a circular metal plate **T** which is one end of an evacuated cylindrical cavity, connected to a vacuum pump or sealed at a desired pressure, or which forms a still containing water or other aqueous solution or liquid. This cavity constitutes the transmitter/receiver gap, and is therefore bounded by a dielectric envelope and wall structure **32**, with the circular receiver plate **R** as its top surface. In turn this plate **R** serves as the base of a conical Faraday cage **34**, preferably air-tight and at atmospheric pressure, but which could also be subject to evacuation, which conical structure carries at its apex provisions for a cold junction **45** and any possible enhancement of the same junction by surface application of different metallic conductors that may optimise the Peltier-Seebeck effect. The output from the cold junction where sensible thermal energy is added to the electrokinetic energy of charge carriers, is also the input to the distal end of the winding **6** of the chiral coil arrangement that sustains resonant capture of all three energy flows ((1) mass-free electric waves of a longitudinal nature, (2) true "latent heat" or the intrinsic (thermal) potential energy, and (3) the thermokinetic energy of molecules, (i.e. "sensible" heat) and, placed in series with the input of

the full wave divider **8, 10**, feeds the circuit output from the series capacitors **12, 14** grounded at their common tap. In the T/R gap, the transmitted electric longitudinal wave energy is captured along with any intrinsic potential energy shed by molecules caught in the field. Within the **R** element, expanded into an enclosure that guides "sensible" radiant heat, the latter is generated and then recaptured at the cold junction.

The apparatus consisting of the cylindrical T/R gap cavity and the contiguous conical cage is then preferably finished in gloss white and cylindrically enveloped within a matt black container **46** by effective thermal insulation **48**, the latter terminating at the height of the bottom disc **T**. Apparatus (not shown) may be provided to move the plate **T** vertically to adjust the T/R gap.

Another alternative embodiment of the apparatus is shown in **Fig.17**. Here the circuit driving the apparatus is as we have set forth in our prior patents, which employs an autogenous pulsed abnormal glow discharge tube **50** in the configuration shown, supplied by a battery pack **DP** through blocking diodes **52** and an RC circuit formed by resistor **54** and capacitor **56** to drive the primary **2** of a first Tesla coil to obtain at the distal pole of the secondary **6** the energy to be injected to plate **T** in the form of a central electrode of a coaxial vacuum chamber (sealed or not), of which the cylindrical metallic envelope forms the receiver plate **R**, the latter being placed centrally inside the conical cage **34** and contiguous with its walls and base. The top and bottom of the coaxial chamber carries suitable insulating discs, preferably with O-ring type fittings. Again, the apparatus is enclosed in insulation within a cylindrical container **46**, and the input into the capture circuit driven from the full wave divider is taken from the cold junction **45** at the apex of the air-tight cage. The output circuit is similar to that of **Fig.15**.

We have found however that even when the component values in the motor driver and motor circuits are carefully selected so that these circuits are co-resonant with the dampened wave (DW) component of the motor driver pulses, the motor power output falls well short of that which should theoretically be attainable. In an endeavour to meet this problem, we replaced the squirrel-cage type induction motor **44** by a drag cup motor of type KS 8624 from Western Electric in the expectation that the low-inertia non-magnetic rotor would allow better response to the Dampened Wave component. This motor is similar to one of the types used by Reich in his experiments. Although results were much improved they still fell short of expectations. Replacement of this motor by an inertially dampened motor of type KS 9303, also from Western Electric, provided much better results as discussed below.

Fundamentally, the difficulties we encountered stemmed from the inability of motor couplings to respond efficiently and smoothly, and at the same time, to the pulse and wave components of Dampened Wave impulses: that is, simultaneously to the high-intensity peak current pulses (the front end event), the DC-like component, and to the dampened wave trains these cause, i.e. the pulse tails (or back end event)-or AC-like component. This difficulty is present even when we just seek to run induction motors from the DW impulses of a Tesla coil, the very difficulty that led Tesla to abandon his project of driving a non-ferromagnetic disc rotor mounted on an iron core bar stator with dampened waves.

We believe that the key to the capture of the mass-free energy flux output in electric form by Tesla transmitters, including any injected latent or thermal energy that have undergone conversion into electrical energy is to employ the tuned, unipolar, Y-fed, PAGD-plasma pulser driven split-phase motor drive we have invented (U.S. Pat. No. 5,416,391) in conjunction with an inertially dampened AC servomotor-generator (see **Fig.18**): this has a motor shaft **64** which couples a drag-cup motor rotor **60**, preferably of aluminium, silver, gold or molybdenum, directly to a drag-cup generator rotor **62** that drives a permanent magnet (PM) flywheel **66**, freely rotatable in bearings **67**, that provides inertial damping. The shaft **64**, journalled by bearings **61** in the casing of the motor **44**, provides a power output through optional gearing **68**. The phase windings of the motor **44** are wound on a stator core **70** having concentric elements between which the rotor or cup **60** rotates. This structure makes it ideal for the capture of the DW impulses, whether sourced in the transmitter, amplified in the T/R cavity or sourced in the plasma pulser, all in synchrony. Effectively the motor couples the damping action of the drag-cup sleeve motor rotor, which action, as we have already found for the KS-8624 motors, is quite effective at absorbing the front-end DC-like event, with the inertial damping of the PM flywheel upon the drag-cup sleeve generator rotor, that in turn is quite efficient at absorbing the back-end AC-like wavetrain event.

The KS-9154 motor used by Reich was not an inertial dampened AC drag-cup servomotor-generator. Had Reich succeeded in overcoming the limitations of his 2-phase OR Motor solution, as we have now shown it is possible to do (by applying the Function Y circuit to the PAGD split-phase motor drive which we invented), his motor would have suffered the same limitations which we encountered with the KS 8624 motor.

Any motor, by itself, has an internal or inherent damping whereby the acceleration only vanishes when the rotor is running at constant speed. For motors which operate on the basis of the drag principle, where the asynchronous slip is actually constitutive of the motor action, by inducing eddy currents in the rotor, the inherent damping is always more pronounced than for other induction motors. The damping or braking torque is produced when a

constant current flows through a rotating drag disc or cup.

Aside from this inherent braking, dampers can also be applied to servo motors to further stabilise their rotation. They absorb energy, and the power output and torque of the motor is thereby reduced. Optimal operation of servo motors requires both rapid response on the part of the rotor to changes in the variable or control phase, and a stable response that is free from oscillation, cogging and overshooting. The rapid response is assured by employing low inertia rotors, such as drag-cups or cast alloy squirrel-cages, and the overshooting and oscillation are reduced to a minimum by damping or a retarding torque that increases with increasing motor speed. Typically, in a viscous-dampened servomotor, the damper is a drag-cup generator mounted rigidly on the shaft of the motor rotor, and the generator drag-cup rotates against the stator field of a static permanent magnet field. The generator develops a retarding torque directly proportional to speed, and the energy absorbed by the damper is proportional to speed squared. The damping can be adjusted and, as it increases, the same amount of input power yields lower torque and motor speeds. Inertial-dampened servo motors differ from viscous dampened motors in that the permanent magnet stator of the drag-cup generator is now mounted in its own bearings, either in the motor shaft or on a separate aligned shaft, forming a high-inertia flywheel.

This means that, whereas the motor rotor always experiences a viscous damping in viscous-dampened servo motors, in inertial-dampened servo motors the drag cup motor rotor only experiences a viscous damping while accelerating the flywheel, with the damping torque always opposing any change in rotor speed. Once the flywheel rotates synchronously with the rotor, all damping ceases. Note that this viscous damping is carried out via the coupling of the drag-cup generator rotor, rigidly affixed to the motor rotor, to the PM flywheel, so that their relative motion generates the viscous torque proportional to the relative velocity. Use of drag-cup sleeve rotors in inertially dampened servo motors was largely supplanted by squirrel-cage rotors once the latter became produced as cast alloy rotors. Since inertially dampened motors can be used in open and closed-loop servo applications, and present better stability - even in the presence of non-linearities - and higher velocity characteristics than other induction motors do (Diamond, A (1965) "Inertially dampened servo motors, performance analysis", *Electro-Technology*, 7:28-32.), they have been employed in antenna tracking systems, stable inertial-guidance platforms, analogue to digital converters, tachometers and torque tables.

The typical operation of an inertially dampened servomotor is as follows: with the reference phase fully excited, the motor rotor -fixedly linked to the generator rotor, as well as the flywheel - remain immobile; once power is applied to the control phase, the motor rotor immediately responds but the flywheel remains at rest. However, as the drag-cup generator **62** is forced to move through the permanent magnetic field of the flywheel, it creates a drag torque that slows down the attached motor rotor proportionally to the acceleration that it imparts to the flywheel that it now sets into motion, thus creating the viscous damper. As the flywheel accelerates, the relative speed of the motor with respect to the flywheel, as well as the damping torque, decrease until both motor and flywheel rotate synchronously and no damping torque is exercised - at which point the drag on the motor cup exerted by the generator cup is negligible.

The KS-9303 motor is an inertial dampened servomotor but is differentiated with respect to other inertially dampened motors, in that (1) it employs a drag-cup sleeve motor rotor made of aluminium, very much like that of the KS-8624, but with slightly altered dimensions and with a shaft extension for the drag-cup copper generator rotor, and (2) the moving flywheel structure was journalled on a separate, fixed shaft, as already described with reference to **Fig.18**. Now, in principle, even application of minimal damping decreases motor efficiency, resulting in diminished torque and speed. Whether the inertial-dampened motor has a drag-cup rotor, a sleeve rotor or a squirrel-cage rotor, the damping increases the rotor slip. Laithwaite considers drag-cup motors as being "dynamically inferior to their cage counterparts" (Laithwaite, E R (1957) "Induction machines for special purposes", London, England, p. 323). If we now add a viscous damping and retarding torque, we should not be able to get much more than a 55% efficiency in the best of conditions. On the other hand, the inertial damping arrangement described will only abstract or supply energy when the motor rotor is accelerating or decelerating relative to the flywheel.

These drag-cup motors, whether inertially dampened or not, develop a constant torque at constant rpm for a given supply frequency and a suitable phase shift capacitance. For each frequency the motors respond to, there is an optimum resonant split-phase capacitance, but other values nearby are still suited for operation, and for each value of capacitance, there is an optimum frequency to which the motors respond. For example the KS-8624 motor responds best at 450 Hz when a 1 microfarad capacitance is employed, responds best at 250 Hz when a capacitance of 10 microfarads is employed, and responds best at 60 Hz, when a capacitance of 100 microfarads is employed. As the capacitance increases, the resonant CW frequency of the motor is displaced to lower values. If we fix the capacitance at a value (e.g. 10 microfarads) suitable for testing the frequency response at a fixed voltage of 12 VAC, the observed result for both the KS-8624 and KS-9303 motors show a response distribution of the motor rotary velocity that has an identical peak at 250 Hz for both motors, with the response decreasing to zero smoothly on both sides of the peak.

These results indicate that, when wired as a split-phase motor, the motor rotary velocity varies not as a function of voltage or current, but as a function of frequency when the phase-splitting capacitance is fixed within a suitable range, there being an optimum frequency mode for each value of suitable capacitance, with lower values of capacitance favouring higher frequency modes. For a given frequency and capacitance, the motor rotary velocity remains essentially constant and independent from voltage and current input, and thus at a plateau. Torque, in the same circuit arrangement, follows exactly the same pattern as rotary velocity, as a function of input frequency at a fixed potential. Torque is linearly proportional to rpm in these motors when they are split-phase wired, and rpm linearly proportional to CW frequency, which makes them ideal for experimentation and determination of power output computations. Moreover, since these are drag machines, the slip itself determines the rotor currents and these are susceptible to tuning such that their retardation and relative position in the field can find resonant modes for varying CW frequency and capacitance.

In the circuit of **Fig.17** when using the KS 9303 motor, the inertial damping of the flywheel coupling retards the motor rotor currents sufficiently to allow them to build up torque, with the entire motor assembly serving as the preferred sink for all of the energy, mass-free and mass-bound, captured by the receiving coil circuit with a drawing action established by the motor on the circuit, and providing satisfactory absorption by an inertial damper of the combined, synchronised, dampened wave impulses, those occurring at a low frequency as a result of the firing of the PAGD reactor, and those occurring at a higher superimposed frequency -sourced in the transmitter circuit and picked-up by the receiver plate and coil. The action of each DW impulse train itself generates two different events: the DC-like auto-electronic-like discontinuity which sets the motor in motion and initiates the rotor currents, and the AC-like dampened wavetrain which supports the consistency of those rotors. The concentration of current required to kick-start the motor is provided by the DW impulses of the PAGD reactor, whereas, once the motor is in motion, and particularly, once it is stabilised by the flywheel, the cumulative action of the higher frequency DW impulses makes itself felt by accelerating the rotor to an optimum rotary velocity.

For the next series of tests we employed the basic circuit diagram of the improved motor shown in **Fig.19**. The transmission station is the typical Tesla transmitter with a line-fed, 60 Hz vibrator stage. At the line input to the first stage, we place a calibrated AC wattmeter (Weston Model 432), and a Beckman 330B rms ammeter in series with the hot lead, we set the vibrator stage for 41 clicks, consuming between 28.5W and 35W, depending upon circumstances yet to be described. This consumption was confirmed by driving the coil from an inverter powered by a 12 volt battery. The inverter consumes 2.16 watts, and is 90% efficient. The total consumption from the battery was 42 watts (12V at 3.5A); once the 2.16 watts is deducted and the efficiency taken into account, we obtain the same 36W (vibrator stage at max., i.e. 47 clicks, in this experiment). The T/R gap is adjusted to 3", and 2 square foot plates are used. Transmitter and receiver coils are tuned, and so are the plate capacitances, to 250 kHz, also the capacitances of the Function Y circuit connected at the output of the receiving coil.

The rectified voltage and current generated by the transmitter secondary and by the transmitter plate was ascertained with a coil-tuned wave-divider (Function Y) circuit by loading it with different resistive values. The results constitute a measure of the mass-bound electrical power output directly from the transmitter apparatus. The same method was employed to ascertain the voltage, current and power of the mass-bound charges circulating in the receiving plate and coil circuit. The results are shown in Table 8 below:

TABLE 8

Massbound currents rectified by Function Y at the output of the Tesla transmitter, transmitter plate and receiver plate, as a function of the bleeding resistance employed in each of the function Y arms				
	VDC (kilovolts)	ADC (amp)	WDC (watts)	R/arm (Mohm)
Direct from 2°	42-50	$3 * 10^{-5}$	1.26-1.5	500
From 2° (T) plate	26	$2 * 10^{-5}$	0.52	500
From 2° (R) plate	15.1	$1.25 * 10^{-5}$	0.189	500
Direct from 2°	20.4	$3.4 * 10^{-4}$	6.936	50
From 2° (T) plate	15.2	$2.4 * 10^{-4}$	3.648	50
From 2° (R) plate	9	$1.2 * 10^{-4}$	1.08	50
Direct from 2°	3.3	$1.75 * 10^{-3}$	5.775	1
From 2° (T) plate	3.5	$2 * 10^{-3}$	7.0	1
From 2° (R) plate	2.95	$1.6 * 10^{-3}$	4.72	1

The results indicate that the highest mass-bound power assembled by the secondary transmitter circuit does not exceed 7 watts - and this is directly output from the secondary **26** when the load is 50 Megohm, or from the transmitter plate when the load is 1 Megohm. The mass-bound electric power emulated by the receiving circuit (plate, coil and Function Y without the plasma pulser circuitry) never exceeds the mass-bound electric power outputted directly by the transmitter, and peaks when the resistive load value (1 Megohm) approaches the pre-breakdown resistance range of the vacuum tube, at 4.72W. These findings then indicate that when the transmitter circuit is consuming a maximum of 35W, a typical output from the secondary of the transmitter is 7W, and at 3" of distance within the proximal field of the latter, the pick-up by a tuned receiver will be of the order of 5W of mass-bound current duplicated within the receiving coil. The loss in the first stage is therefore on the order of sevenfold.

Continuing with the description of the circuit of **Fig.19**, a 128 cm² plate area, 6 cm gap PAGD reactor is used, connected as described in our prior art to a high-vacuum rotary pump (Correa, P & Correa, A (1995) "Energy conversion system", U.S. Pat. No. 5,449,989). Pressure readings were obtained with a thermocouple gauge during the operational runs. The KS-9303 motors to be tested are then connected to the PAGD reactor in the usual capacitatively-coupled, inverter fashion described in our prior art (Correa, P & Correa, A (1995) "Electromechanical transduction of plasma pulses", U.S. Pat. No 5,416.391). Their rpm is detected by a stroboscopic tachometer and fed to a Mac Performa 6400 running a motor algorithm program calculating the power output. Motor measurements were made at five minutes into each run for the unloaded motors, and at ten minutes for the inertially dampened motors.

All experiments were carried out in the same work session. The experimental determination of the continuous rotary power output as a function of the reactor pulse rate confirmed that the improved circuit develops maximum rotary capture of the mass-free energy in the receiver circuit at the lowest rates of pulsation, just as we have previously found for the conversion system of U.S. Pat. No. 5,449,989. Furthermore, the data showed that even motors of type KS-8624 are able to output power mechanically in excess of the mass-bound power output by the transmitter (7W) or captured by the receiver (5 to a max. of 7W), once the PAGD rate decreases to 1.5 PPS. Such an anomaly can only be explained by the system having become able to begin capturing the mass-free energy flux in the receiver circuit that we know already is output by the transmitter circuit. But this excess mechanical power is still less than the power input into the transmitter, and clearly so. It represents a power gain with respect to the secondary, but a loss with respect to the primary. The full breadth of the capture of the mass-free electric energy flux circulating in the receiver circuit is not seen until the motors are resonantly loaded because they are inertially dampened.

The KS-9303 motors, once inertially dampened, and thus loaded, are able to recover enough power from the mass-free energy field to develop a mechanical power, not just greatly in excess of the mass-bound power of the secondary, but also greatly in excess of the mass-bound power input to the vibrator stage and the primary, at 28 to 35W. Once the pulse rate approaches the same 1.5 PPS marker, mechanical power in excess of the mass-bound electric power input to the primary becomes evident, peaking at nearly three times that input. In fact, the highest output recorded was also obtained with the lowest input to the transmitter circuit, the highest exact coefficient observed in this experiment being $100.8W / 28W = 3.6$. Furthermore, with respect to the secondary mass-bound output, the same mechanical rotary output represents a much greater overunity coefficient of performance, on the order of 14.4 times greater. This is at least partly the result of the receiver and motor capture of the mass-free electric energy output by the transmitter, and may be partly the result of mass-free energy engrafted by the PAGD regime in the PAGD reactor.

Reviewing the mechanical power output results as a function of increasing vacuum in the PAGD reactor and at different output power levels, any motor performance below the 5-7W limit of the traditional mass-bound output power of the secondary represents an output mechanical power loss with respect to both the mass-bound secondary output and the mass-bound primary input. All the results for pressures down to 0.03 Torr fall into this category, and thus represent a very inefficient coupling to the PAGD regime. Any motor performance between 7W and 28-35W represent a loss with respect to the electrical power input to the transmitter system, but a net gain of power with respect to the mass-bound secondary power output. None of the non-inertially dampened motors tested were able to perform outside of this area, under the test conditions. With more efficient primary to secondary couplings in the transmitter station, however, one could advantageously employ these motors alone to extract some of the mass-free power of the secondary or to operate them in enclosed vessels without conventional external electrical connections.

To reach satisfactory levels of recovery of mass-free energy, one must dampen the superimposed DW impulses. Hence, all results showing outputs in excess of 35W were obtained using the inertially dampened KS-9303 motors, and represent a net overunity power gain over both the power input to the primary and the mass-bound power output by the secondary, or the mass-bound power emulated by the receiver circuitry. This happens when the PAGD pulse rate falls to 2 PPS, with the rotary power output steeply increasing as the rate falls to 1 PPS.

One of the interesting features of the motor circuitry we have proposed is that it can operate with pulsed plasmas in both the TRD and the AGD regions, the least efficient response occurring in the NGD region near the Paschen minimum. One might think that the voltage depression would allow increased current intensity supplied to the motors, but in fact that is not observed, with the flashing of the NGD yielding erratic oscillations and low values of current. In keeping with the notion that the TRD plasma is mainly composed of lagging positive ions, whereas the PAGD plasma is mostly an electron plasma, the observed direction of rotation of the motors is opposite in the TRD region to that of the AGD region. The NGD region therefore marks the depression where the velocity vectors change direction. In the second or PAGD region, motor operation is very quiet, unlike what is observed in the TRD region.

Part and parcel of the tuning of the circuit components is the selection of the optimum capacitances employed to couple the PAGD reactor to the motor circuit and split the phase to feed the auxiliary winding of the motor. We have experimented with capacitances ranging from 0.5 to 100 microfarads, and found that best results (for the specific circuit in question - including the characteristics of the transmission), were such that the optimum value of the PAGD coupling capacitance lay near 4 microfarads, and the phase splitting capacitance, near 1 to 4 microfarads, depending upon weather conditions. In good weather days lower capacitance values can be used, while in bad weather days higher capacitances are needed. For ease of comparison in demonstrating the need to tune the circuit by employing optimum capacitances in those two couplings (reactor to motor, and motor phase coupling), we employed the same capacitances in both circuit locations.

A comparison of tests using 1 and 4 microfarad values shows the difference caused by changing those capacitances from their optimum value: across all discharge regions of the pressure range that was examined, the four motors tested, operated with greater motor speeds when the capacitances are set to 4 microfarads rather than to 1 microfarad. The less efficient performance obtained with 1 microfarad capacitance fits the inverse correlation of pulse power with increasing pulse frequency, such as we have found for the PAGD regime. This is made evident by a comparison of rpm versus pulse rate for the two capacitance values being considered. They demonstrate the higher pulse rates observed with the lower capacitance, that correlate with the lower motor speeds, and result in lower efficiency of the motor response. The results equally indicate that low capacitance values increase the pulse rate, but if this increase is out of tune with the rest of the circuit values, it results in power waste because it imposes a rate that is not optimum.

We have also determined experimentally that the efficiency of the system is affected by external weather conditions, higher efficiencies being noted on a fine bright day than under poor weather conditions even though the apparatus is not exposed to such conditions. This may reflect a diminution under poor weather conditions of latent mass-free energy that can be taken up by the system.

The observed high efficiency of circuits including inertially dampened motors indicates that the phenomenon does not reduce to a mere optimum capture of, DC-like pulses produced by the reactor in what is essentially an AC motor circuit. Effectively, the pulsed plasma discharge deploys a front-end, DC-like pulse, or discontinuity, but this is followed by an AC-like dampened wave of a characteristic frequency (having a half-cycle periodicity identical to that of the front-end pulse) to which the motor circuit also responds. Moreover, the mass-free electric radiation from the transmitter circuit itself induces, in the receiver antenna, coil and circuit, and in the reactor discharge itself, the train of finer dampened wave impulses responsible, after conversion through the wave-divider, for the mass-bound rectified current which is employed to charge the plasma reactor to begin with. Serving as trigger of the plasma discharges in the reactor are the DW impulses circulating in the receiver circuit, such that the two different lines of DW impulses, in the receiver circuit (for example 120 PPS for the pulses and 154 kHz for the waves) and from the reactor, are synchronised by interpolated coincidences, since their pulse and wave frequencies are different. Ideally, these two superimposed DW frequencies are harmonics or made identical. The receiver stage involves capture of the mass-free electric energy received from the transmitter, duplication of the mass-bound current in the receiver coil, and injection of latent and sensible thermal energy in the T/R gap cavity which augments the emulated mass-bound current.

The mass-bound current is employed to charge the wave-divider capacitance bridge and therefore the reactor. In turn, the plasma pulses from the reactor are superimposed with the DW impulses from the receiving coil, and together they are coupled to the split-phase motor drive. Hence the first receiver stage employs the totality of the energy captured in the T/R gap cavity - mass-free electric energy transmitted by the **T** plate, latent and sensible thermal energy injected at the surface of the **R** plate - and produces in the receiving coil a mass-bound current comparable to that assembled in the transmitter coil by the action of the primary. The mass-bound current is stored in the wave-divider bridge and used to drive the plasma reactor in the PAGD region. Subsequently, the autogenous disruptive discharge that employs a substantial electron plasma generates both a concentrated, intense flux of mass-bound charges in the output circuit, and a mass-free oscillation of its own. The dampened motor is therefore fed directly with (1) the intense mass-bound current output from the reactor; (2) the pulse and wave components of the mass-free electric energy captured by the receiver plate and coil (and matched by conduction through the earth), and which are gated through the wave-divider and the reactor for the duration of the PAGD channel; and (3) any mass-free latent energy taken up from the vacuum by the PAGD event. Once the

motor is set into motion, and is resonantly loaded with an inertial damper, we believe that it will also respond to the much weaker DW impulses captured by the receiver, since these impulses encompass both a DC-like front end - further enhanced by analytic separation through the wave-divider - and a dampened wave at 154 kHz.

Essentially, the DW impulses that are ultimately sourced in the transmitter - and received unipolarly through the T/R gap - have sufficient DC-like potential (plus all the other requisite physical characteristics, such as frequency) to contribute directly to the motor response, once the motor has gained substantial speed (for they lack the current to set it into motion, one of the contributions from the plasma pulser). This is the case, provided that the motor itself is suited for absorption of both DC-like pulses and AC-like dampened waves, which is precisely the case with motors of the type shown in **Fig.18** since the inertia of the flywheel is overcome through homopolar absorption of the dampened oscillations simultaneously in the motor drag-cup rotor and in the generator drag-cup rotor.

We also tested these inertially dampened motors in the traditional DC power supply-driven PAGD circuit we have taught in our previous patents, that is, circuits with an overt HV DC power source, and thus in the absence of any Function Y circuit or transmitter circuit. Here then, only the DW impulses generated by the PAGD reactor can account for the motor response. The tube employed (A31) had an area of 256 cm², and a gap distance of 4 cm. Coupling capacitances employed were 4 microfarads for the inverter coupling, and 1 microfarad for the split phase motor coupling. The DC power supply delivered up to 1 ampere of current between 150 and 1,000 VDC, and the ballast resistor was adjusted to 215 ohms. Having determined the basic physical characteristics of the reactor's behaviour in the circuit under consideration, we conducted our experiment in the PAGD region. We chose a pressure of 0.6 Torr, just off from the Paschen minimum, as we intended to benefit from the lower sustaining voltage which it affords.

The experiment basically consisted of increasing the sustaining voltage at this fixed pressure in the PAGD regime, and measuring the diverse physical parameters of the circuit and motor response in order to ultimately ascertain the difference between the input electric DC power and the output mechanical rotary power. We first looked at how the motor rpm response varied as a function of the sustaining voltage (V_s): the results illustrate the importance of starting close to the Paschen minimum in the pressure scale, since the KS-9303 motors reach plateau response (at 17,000 rpm) when the reactor output voltage nears 450V. Any further increase in potential is simply wasted. Likewise, the same happened when we measured motor speed as a function of increasing peak DC current, plateau response being reached at 0.1 ADC. Again, any further increase in current is wasted. Essentially then, the optimal power input to the reactor when the output of the latter is coupled to the motor, lies around 45 watts. This is a typical expenditure in driving a PAGD reactor. As for pulse rate we once again find a motor response that is frequency proportional in the low frequency range, between 10 and 40 PPS (all pulse rates now refer solely to PAGDs per sec), but once rates of >40 PPS are reached, the response of the motor also reaches a plateau.

The observed increment in speed from 40 to 60 PPS translates only into an increase of 1,000 RPM, from 16,000 to 17,000 RPM. So, we can place the optimal PAGD rate at ca 40 PPS. The DC electric power input to drive the PAGD reactor was next compared to the rotary mechanical power output by the inertially loaded motor, driven in turn by the reactor. This comparison was first carried out with respect to the PAGD rates. The motor response far exceeds the conventional input power, indicating that the whole system can be tuned to resonance such that optimal power capture inside the reactor takes place, the critical limit rate lying at around 60 PPS, when the motor response is firmly within the pulse response plateau. At this juncture, the break-even efficiency for the measured rates of energy flux over time reach 700% (overunity coefficient of 7), in keeping with the observations and the values we have made in the PAGD conversion system. In the proportional part of the curve, before the plateau is reached, even greater rates of break-even efficiency - up to >1,000% were registered.

These results constitute the first time we have been able to confirm the presence of output energy in excess of break-even over conventional mass-bound energy input in the PAGD inverter system, and the results are comparable to what we have observed and previously reported for the PAGD converter system. At pulse rates greater than 60 PPS a greater input power results in decreased efficiency, also translated into a noticeable heating of the reactor and motor. And this is all the more remarkable as experiments we have conducted with inductive tuning of PAGD reactors, or employing PAGD reactors as replacements for the primaries of Tesla coil assemblies, and still, more recently, with the PAGD inverter circuit driving motors, have all shown that it is possible to operate these reactors with minimal mirroring and heating, preserving essentially the cold-cathode conditions and yet focusing the plasma column so that deposition on the insulator is negligible. It appears that above a certain threshold of optimal efficiency, surplus input energy is just dissipated thermally by both the reactor and the motors.

It should be understood that the above described embodiments are merely exemplary of our invention, and are, with the exception of the embodiments of **Figs. 16 to 19** designed primarily to verify aspects of the basis of the invention. It should also be understood that in each of these embodiments, the transmitter portion may be omitted

if an external or natural source of Tesla waves is available, provided that the receiver is tuned to the mass-free radiation mode of the source. For example if solar radiation is available in which the mass-free component has not interacted with the earth's atmosphere (as in space applications), the receiver is tuned to the voltage wave of the mass-free radiation sourced in the sun, e.g. by using a Tesla coil in the receiver constructed to have an appropriate voltage wave close to the 51.1 kV characteristic of such radiation.

CLAIMS

1. A device for the conversion of mass-free radiation into electrical or electrokinetic energy comprising a transmitter of mass-free electrical radiation having a dampened wave component, a receiver of such radiation tuned to resonance with the dampened wave frequency of the transmitter, a co-resonant output circuit coupled into and extracting electrical or electrokinetic energy from the receiver, and at least one of a transmission cavity between the transmitter and the receiver, a full-wave rectifier in the co-resonant output circuit, and an oscillatory pulsed glow discharge device incorporated in the co-resonant output circuit.
2. A device according to claim 1, wherein the output circuit comprises a full wave rectifier presenting a capacitance to the receiver.
3. A device according to claim 2, wherein the output circuit comprises an electric motor presenting inductance to the receiver.
4. A device according to claim 3, wherein the motor is a split phase motor.
5. A device according to claim 4, wherein the motor is a drag motor having a non-magnetic conductive rotor.
6. A device according to claim 5, wherein the motor has inertial damping.
7. A device according to claim 6, wherein the motor has a shaft, a drag cup rotor on the shaft, and inertial damping is provided by a further drag cup on the shaft.
8. A device according to claim 6, wherein the transmitter and receiver each comprise at least one of a Tesla coil and an autogenous pulsed abnormal glow discharge device.
9. A device according to claim 8, wherein the transmitter and receiver both comprise Tesla coils, and further including a transmission cavity which comprises spaced plates connected respectively to the distal poles of the secondaries of Tesla coils incorporated in the transmitter and receiver respectively.
10. A device according to claim 9, wherein the plates are parallel.
11. A device according to claim 9, wherein the plates are concentric.
12. A device according to claim 9, wherein at least the receiver comprises a Tesla coil driving a plasma reactor operating in PAGD (pulsed abnormal glow discharge) mode.
13. A device according to claim 1, wherein the transmitter and receiver each comprise at least one of a Tesla coil and an autogenous pulsed abnormal glow discharge device.
14. A device according to claim 12, wherein the transmitter and receiver both comprise Tesla coils, and further including a transmission cavity which comprises spaced plates connected respectively to the distal poles of the secondaries of Tesla coils incorporated in the transmitter and receiver respectively.
- 15-17. (cancelled)
18. A device according to claim 1 wherein a transmitter/receiver cavity is present and filled with an aqueous liquid.
19. A device for the conversion of mass-free radiation into electrical or electrokinetic energy comprising a receiver of such radiation from a source of mass-free electrical radiation having a dampened wave component, the receiver being tuned to resonance with the dampened wave frequency of the source, a co-resonant output circuit coupled into and extracting electrical or electrokinetic energy from the receiver, and at least one of a transmission cavity between the source and the receiver, a full-wave rectifier in the co-resonant output circuit, and an oscillatory pulsed glow discharge device incorporated in the co-resonant output circuit.

PAULO and ALEXANDRA CORREA

US Patent 5,449,989

12th September 1995

Inventors: Correa, Paulo and Alexandra

ENERGY CONVERSION SYSTEM

This patent shows a method of extracting environmental energy for practical use. In the extensive test runs, an input of 58 watts produced an output of 400 watts (COP = 6.9). This document is a very slightly re-worded copy of the original.

ABSTRACT

An energy conversion device includes a discharge tube which is operated in a pulsed abnormal glow discharge regime in a double ported circuit. A direct current source connected to an input port provides electrical energy to initiate emission pulses, and a current sink in the form of an electrical energy storage or utilisation device connected to the output port captures at least a substantial proportion of energy released by collapse of the emission pulses.

US Patent References:

3205162	Sep, 1965	MacLean.
3471316	Oct, 1969	Manuel.
3705329	Dec, 1972	Vogeli.
3801202	Apr, 1974	Breaux.
3864640	Feb, 1975	Bennett.
3878429	Apr, 1975	Iwata.
4009416	Feb, 1977	Lowther.
4128788	Dec, 1978	Lowther.
4194239	Mar, 1980	Jayaram et al.
4443739	Apr, 1984	Woldring.
4489269	Dec, 1984	Edling et al.
4527044	Jul, 1985	Bruel et al.
4772816	Sep, 1988	Spence.
4896076	Jan, 1990	Hunter et al.
5126638	Jun, 1992	Dethlefsen.

Other References:

- Tanberg, R. "On the Cathode of an Arc Drawn in Vacuum", (1930), Phys. Rev., 35:1080.
- Kobel, E. "Pressure & High Vapour Jets at the Cathodes of a Mercury Vacuum Arc", (1930), Phys. Rev., 36:1636.
- Aspden, H. (1969) "The Law of Electrodynamics", J. Franklin Inst., 287:179.
- Aspden, H. (1983) "Planar Boundaries of the Space-Time Lattice" Lettere Al Nuovo Cimento, vol. 38, No. 7, pp. 243-246.
- Aspden, H. (1980) "Physics Unified", Sabberton Publications, pp. 14-17, 42-45, 88-89, 190-193.
- Pappas, P. T. (1983) "The Original Ampere Force and Bio-Savart & Lorentz Forces", Il Nuovo Cimento, 76B:189.
- Graham, G. M. & Lahoz, D. G. (1980) "Observation of Static Electromagnetic Angular Momentum in Vacuo", Nature, vol. 285, pp. 154 & 155.
- Sethlan, J. D. et al., "Anomalous Electron-Ion Energy Transfer in a Relativistic-Electron-Beam-Plasma" Phys. Rev. Letters, vol. 40, No. 7, pp. 451-454 (1978).

REFERENCE TO RELATED APPLICATIONS

This application is a continuation-in-part of U.S. application Ser. No. 07/922,863, filed Jul. 31, 1992 (abandoned), and is also a continuation-in-part of U.S. patent application Ser. No. 07/961,531, filed Oct. 15, 1992, now U.S. Pat. No. 5,416,391.

BACKGROUND OF THE INVENTION

1. Field of the Invention:

This invention relates to energy conversion circuits utilising discharge tubes operating in the pulsed abnormal glow discharge (PAGD) regime.

2. Review of the Art:

Such discharge tubes and circuits incorporating them are described in our co-pending U.S. patent application Ser. Nos. 07/922,863 and 07/961,531. The first of these applications discloses discharge tube constructions particularly suited for PAGD operation, and the second discloses certain practical applications of such tubes, particularly in electric motor control circuits. The review of the art contained in those applications is incorporated here by reference, as is their disclosure and drawings.

It is known that there are anomalous cathode reaction forces associated with the cathodic emissions responsible for vacuum arc discharges, the origin and explanation of which have been the subject of extensive discussion in scientific literature, being related as it is to on-going discussion of the relative merits of the laws of electrodynamics as variously formulated by Ampere, Biot-Savart and Lorentz. Examples of literature on the subject are referenced later in this application.

SUMMARY OF THE INVENTION

The particular conditions which prevail in a discharge tube operated in the PAGD regime, in which a plasma eruption from the cathode is self-limiting and collapses before completion of a plasma channel to the anode gives rise to transient conditions which favour the exploitation of anomalous cathode reaction forces.

We have found that apparatus utilising discharge tubes operated in a self-sustaining pulsed abnormal glow discharge regime, in a double ported circuit designed so that energy input to the tube utilised to initiate a glow discharge pulse is handled by an input circuit substantially separate from an output circuit receiving energy from the tube during collapse of a pulse, provides valuable energy conversion capabilities.

The invention extends to a method of energy conversion, comprising initiating plasma eruptions from the cathode of a discharge tube operating in a pulsed abnormal glow discharge regime utilising electrical energy from a source in a first circuit connected to said discharge tube, and capturing electrical energy generated by the collapse of such eruptions in a second circuit connected to the discharge tube.

BRIEF DESCRIPTION OF THE DRAWINGS

The invention is described further with reference to the accompanying drawings, in which:

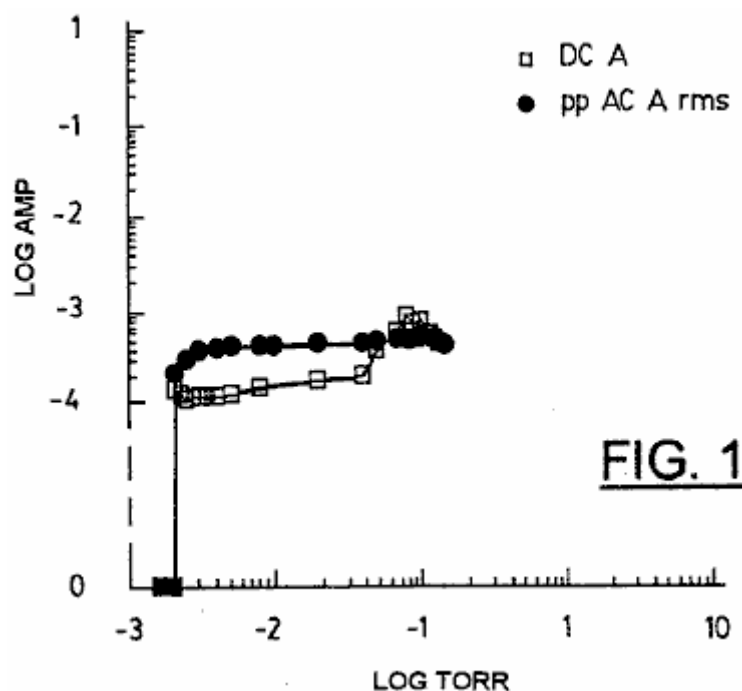

Fig.1 shows variation of applied DC current and pulse AC rms currents characteristic of a low current PAGD regime, as a function of decreasing pressure, for a 128 cm² H34 aluminium plate pulse generator having a 5.5 cm gap length and being operated in the single or plate diode configuration of FIG. 11A, at about 600 V DC.

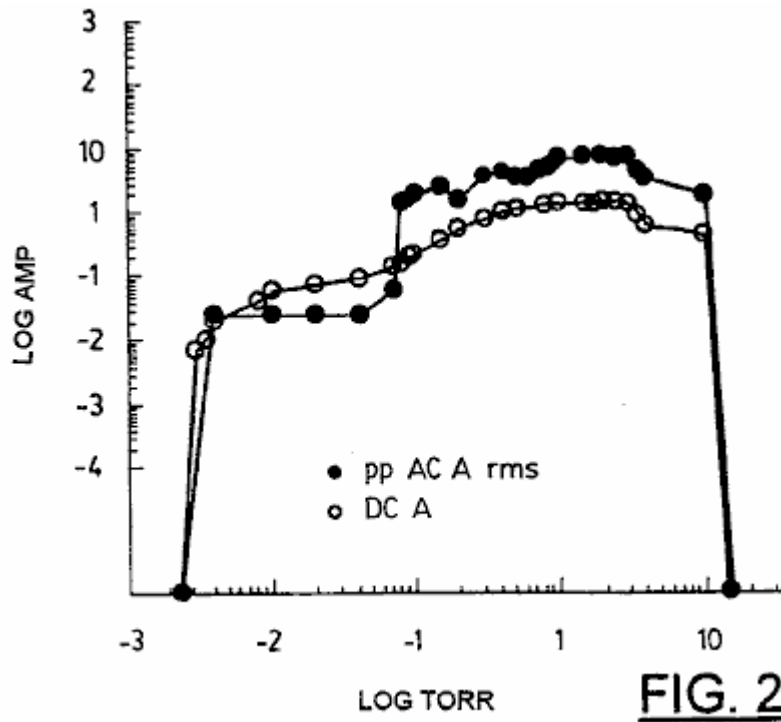

Fig.2 shows variation of applied DC current and AC rms currents of a high current PAGD regime, as a function of the decreasing pressure, for a device identical to that of Fig.1, and operated at the same potential.

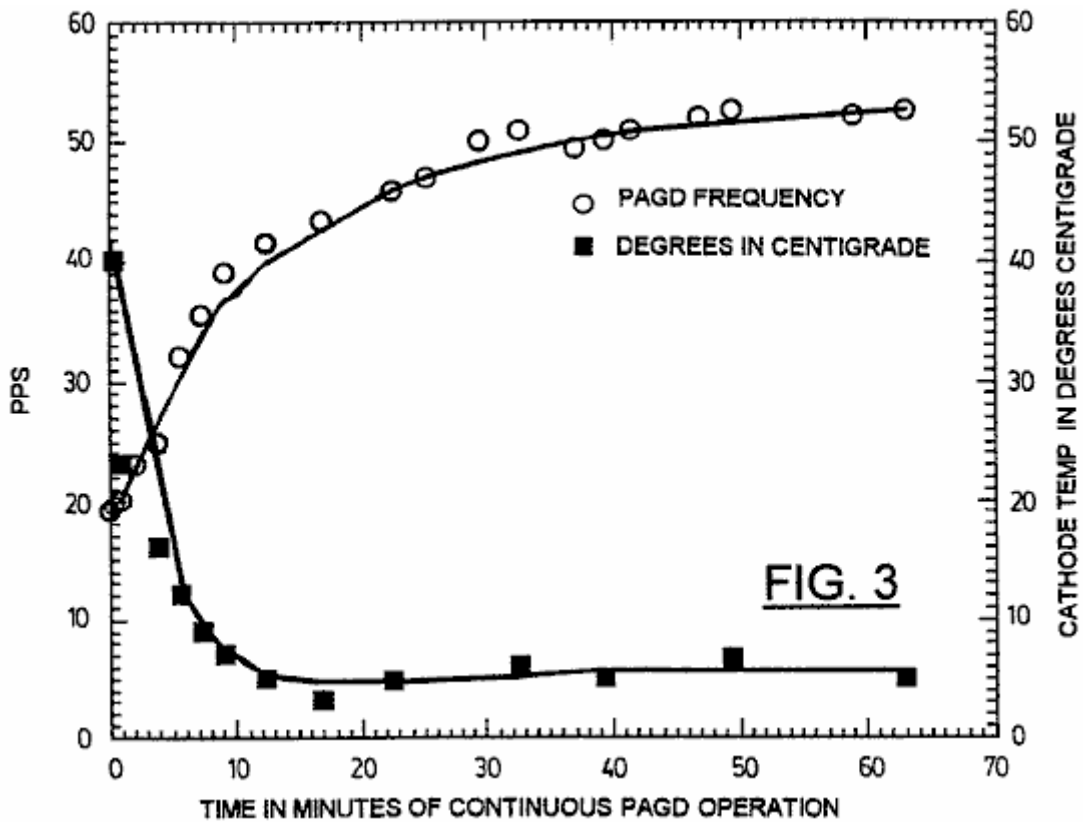

Fig.3 shows PAGD rate vs pulse generator cathode temperature as a function of the time of continuous PAGD operation, for a pulse generator with 64 cm² plates having a 4 cm gap distance, operated at a DC voltage of 555 (av) and R1 = 600 ohms (see Fig.9).

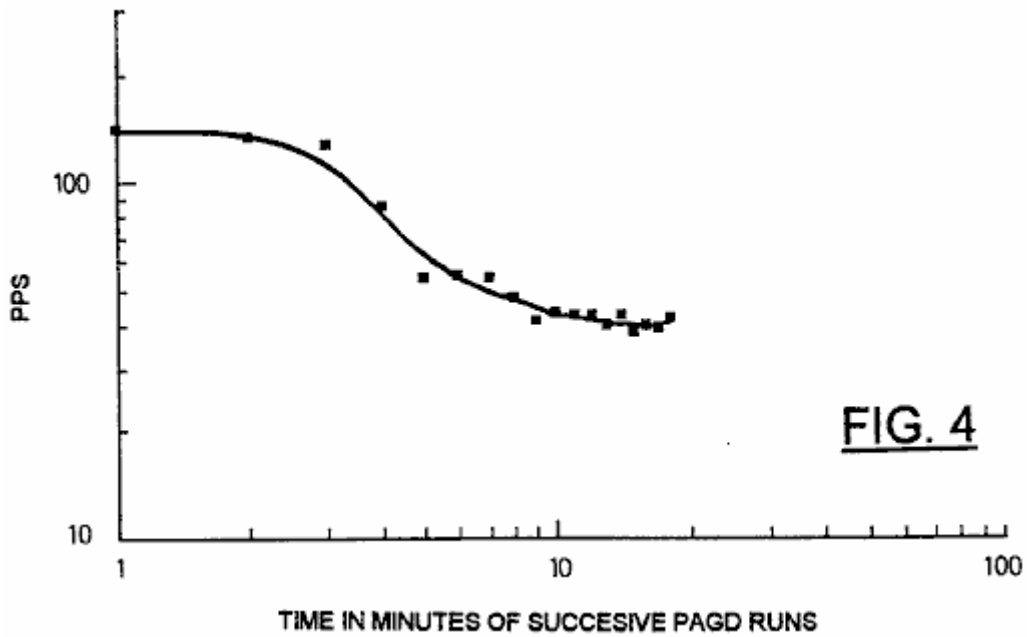

Fig.4 shows PAGD frequency variation with time, for 18 successive spaced one-minute PAGD runs for a pulse generator with 128 cm² plates, and a 5.5 cm gap distance, operated at V DC = 560 (av) and R1 = 300 ohms.

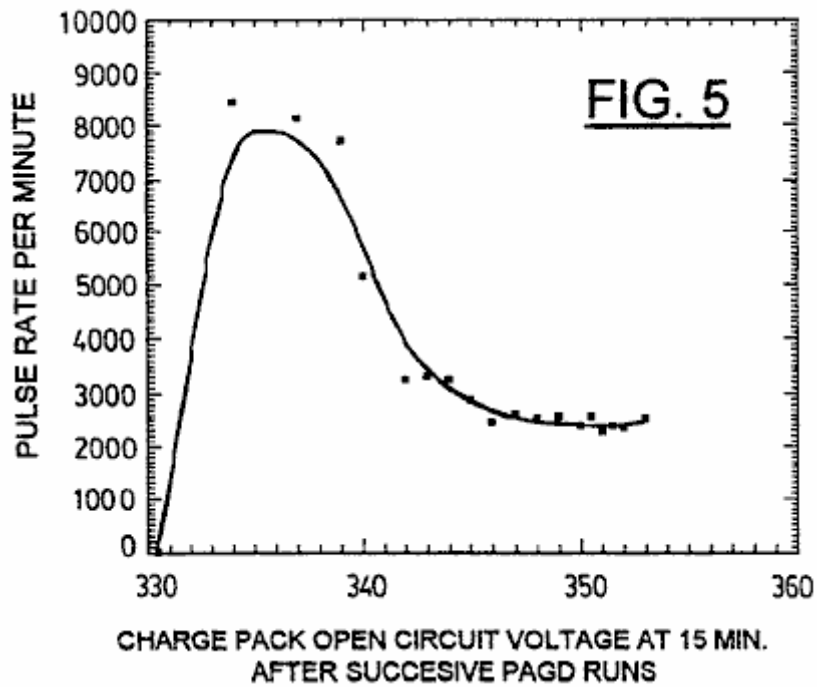

Fig.5 shows variation of the PAGD frequency in pulses per minute (PPM) with increasing charge of a PAGD recovery charge pack (see Fig.9), as measured in terms of the open circuit voltage following 15 minutes of relaxation after each one minute long PAGD run, repeated 18 times in tandem, under similar conditions to Fig.4.

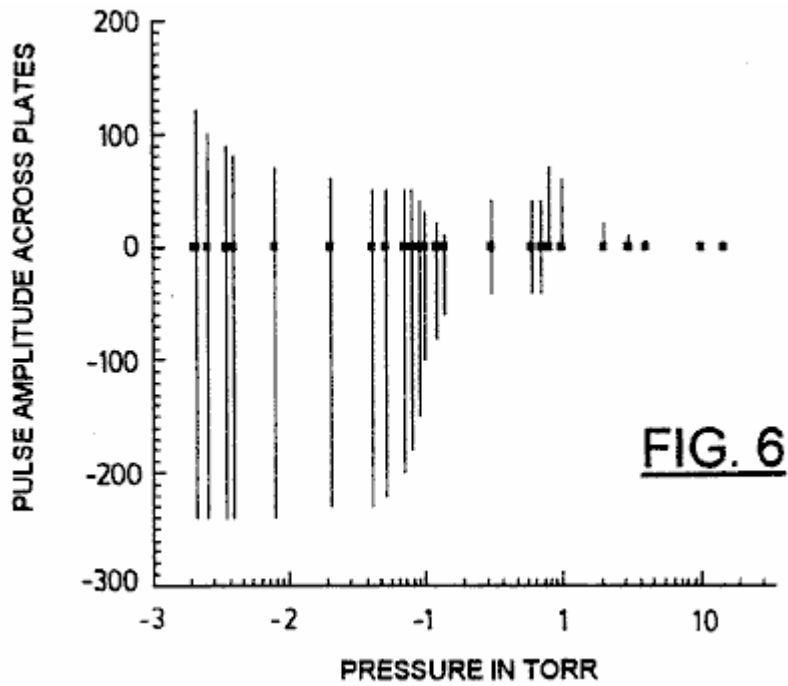

Fig.6 shows volt amplitude variation of continuous PAGD at low applied current, as a function of decreasing air pressure, for a 128 cm^2 plate area device, gap length = 5 cm; (DC V at breakdown = 860).

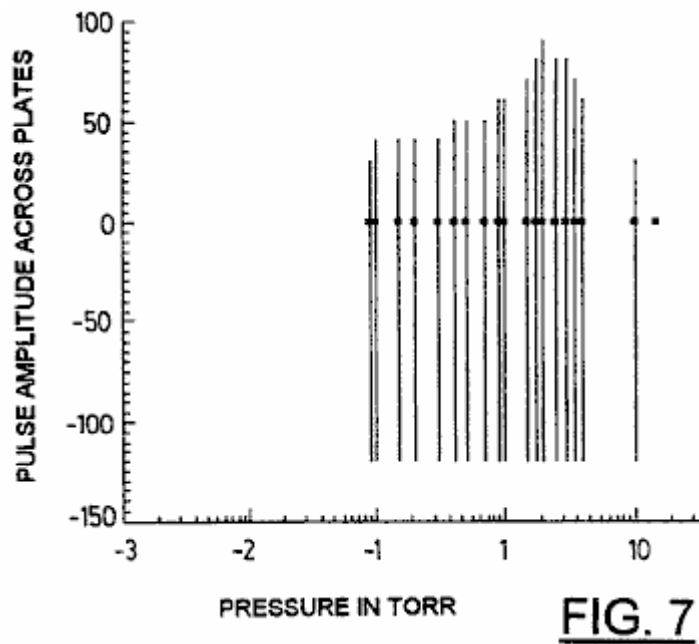

Fig.7 shows volt amplitude variation of continuous PAGD at high applied current as a function of the decreasing air pressure, for a 128 cm^2 plate area device, gap length = 5 cm; (DC V at breakdown = 860).

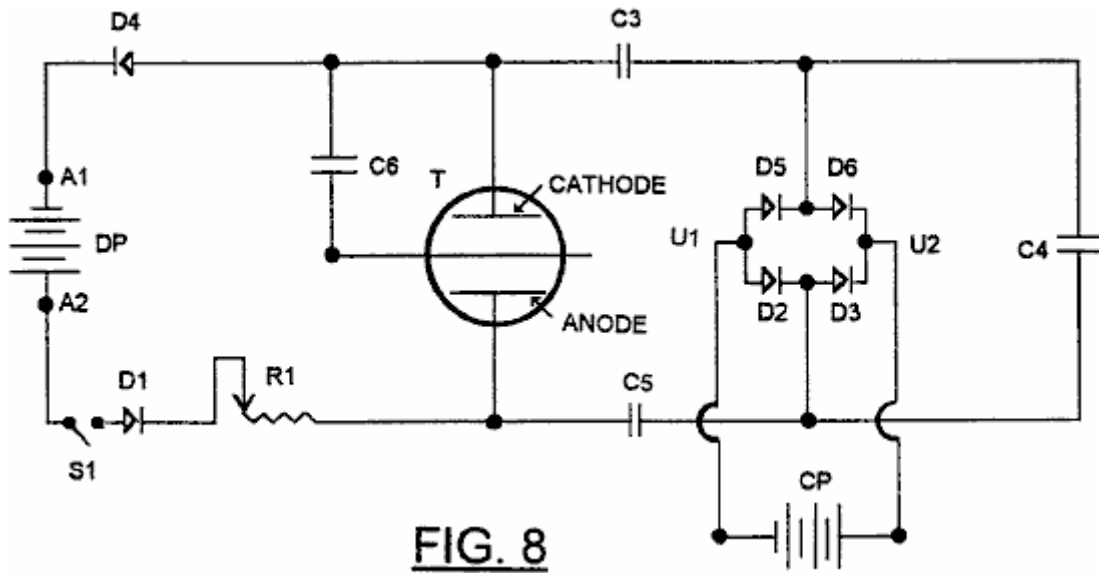

FIG. 8

Fig.8 is a schematic diagram of a first experimental diode (without C6) or triode PAGD circuit.

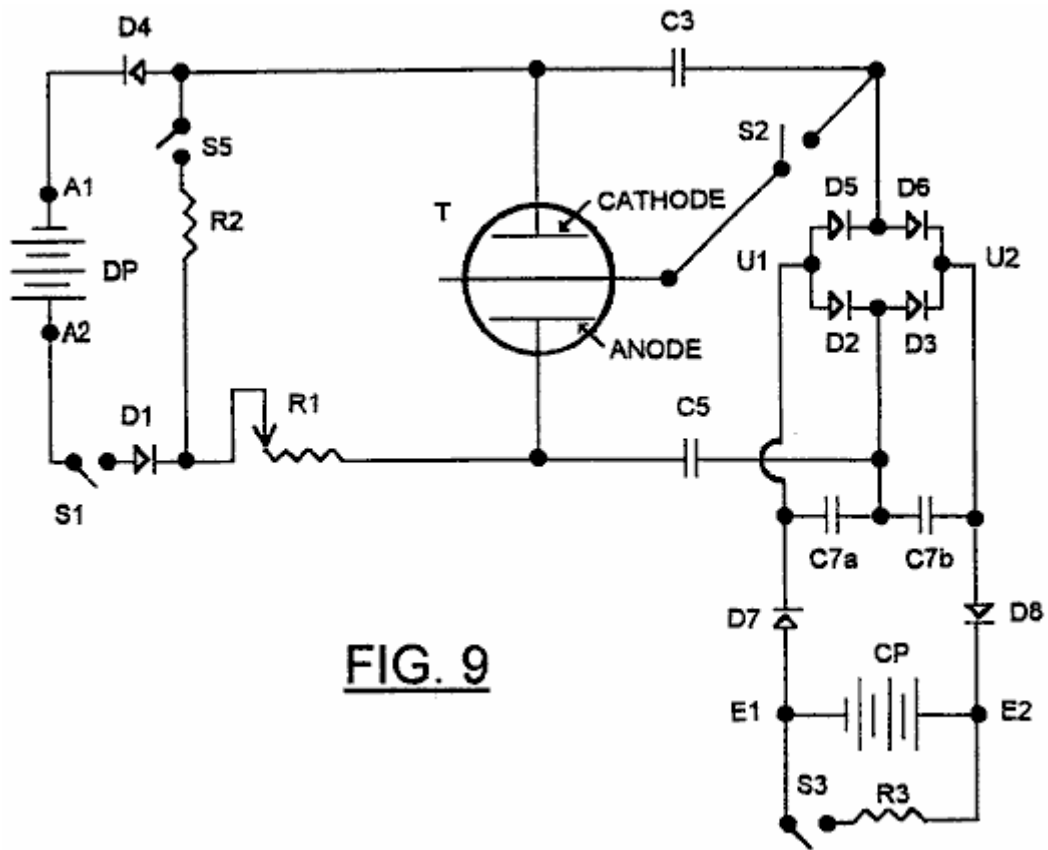

FIG. 9

Fig.9 is a schematic diagram of a preferred diode or triode PAGD circuit in accordance with the invention.

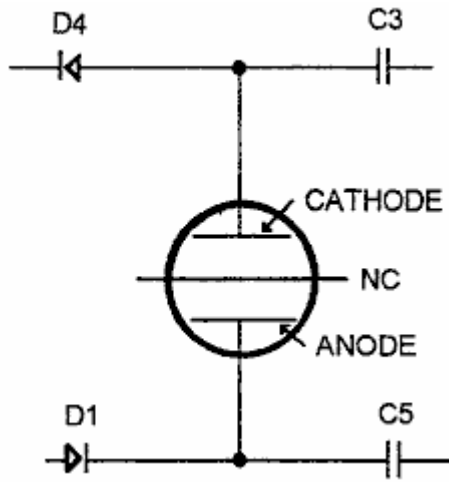

FIG. 10A

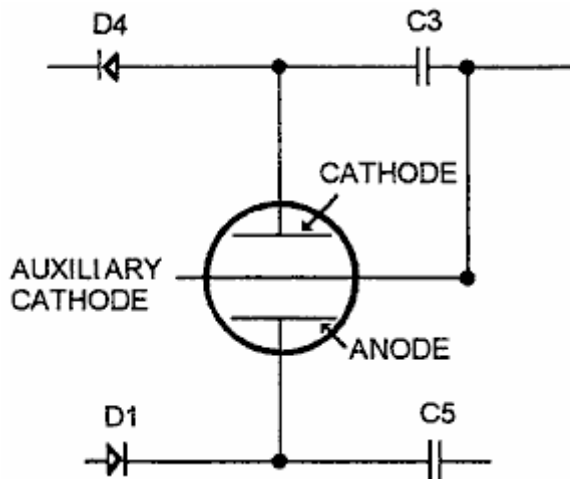

FIG. 10B

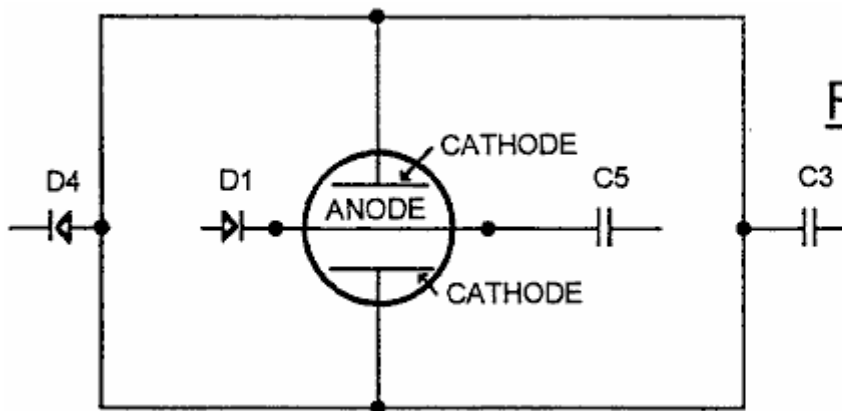

FIG. 10C

Fig.10A, Fig.10B and **Fig.10C** are fragmentary schematic diagrams showing variations in the configuration of the circuit of Fig.9.

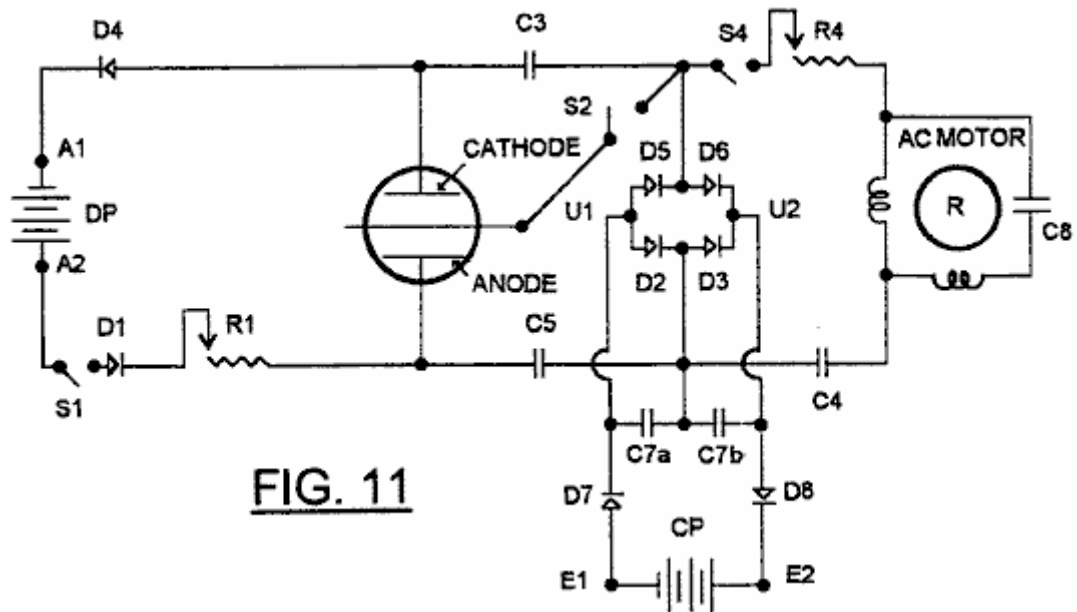

FIG. 11

Fig.11 is a modification of Fig.9, in which an electromagnetic machine, in the form of an electric motor, is connected into the circuit as an accessory electromechanical arm.

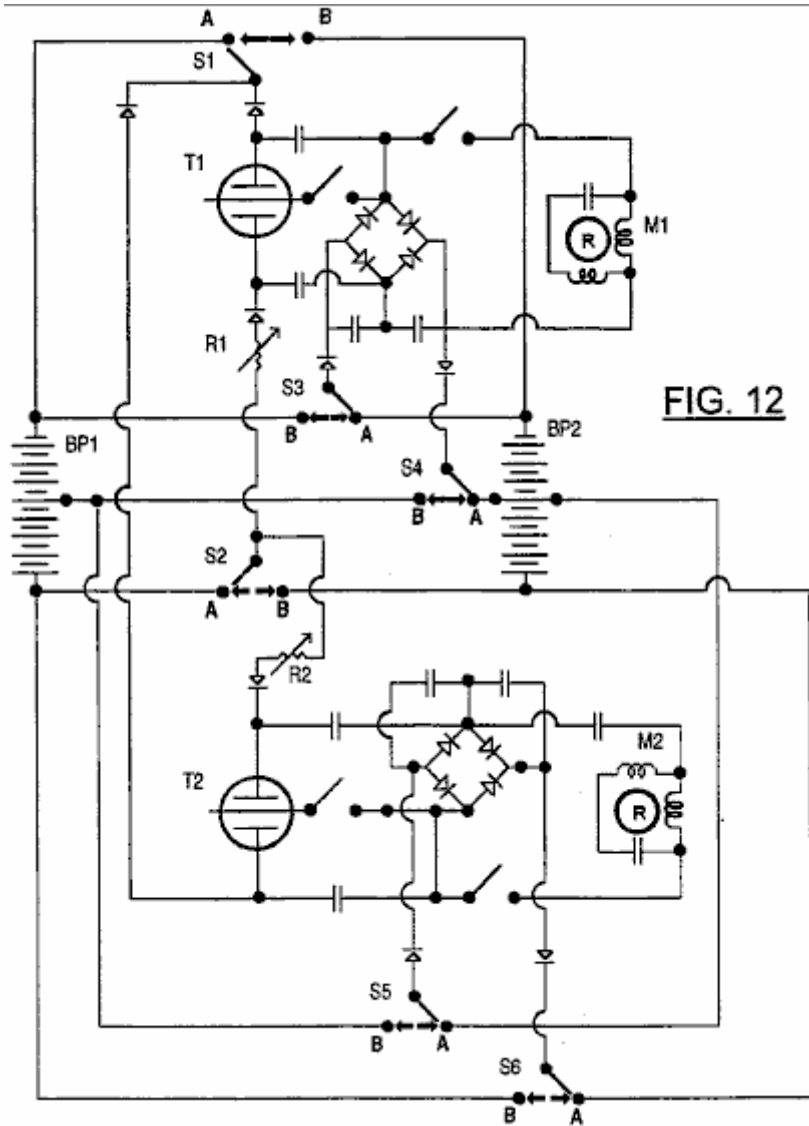

FIG. 12

Fig.12 shows a further development of the circuit of Fig.9, permitting interchange of driver pack and charge pack functions.

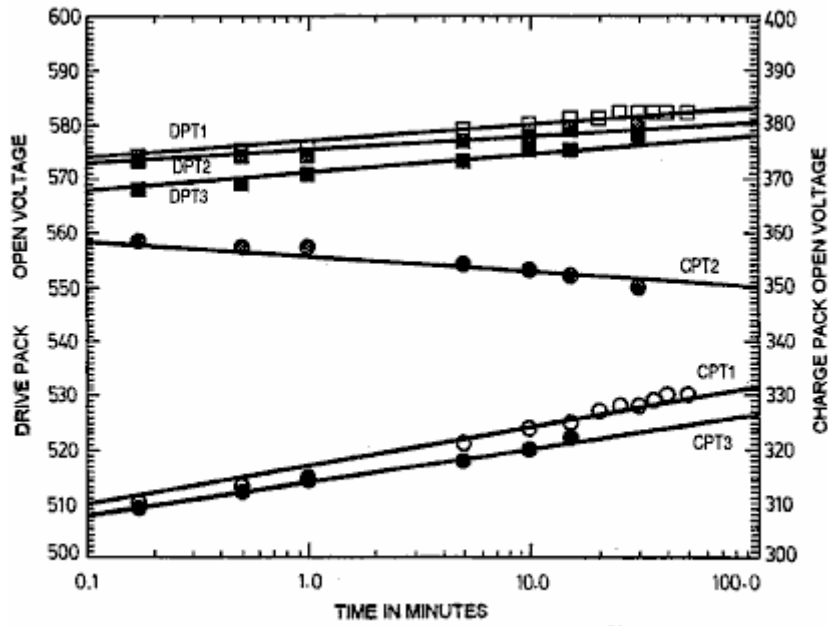

FIG. 13

Fig.13 shows open circuit voltage relaxation curves for battery packs employed in tests of the invention, respectively after pre-PAGD resistive discharge (DPT1 and CPT1), after a PAGD run (DPT2 and CPT2) and after post-PAGD resistive discharge (DPT3 and CPT3).

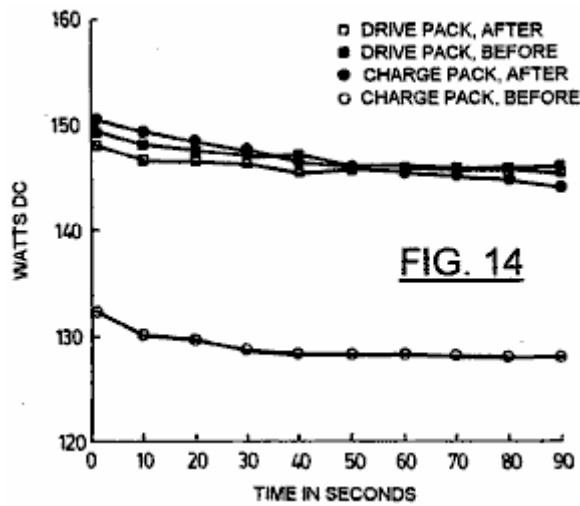

FIG. 14

Fig.14 shows an example of negligible actual power measurements taken immediately before or after a PAGD run, showing both the drive pack loss and the charge pack gain in DC Watts; DP resistance = 2083 ohms; CP resistance = 833 ohms.

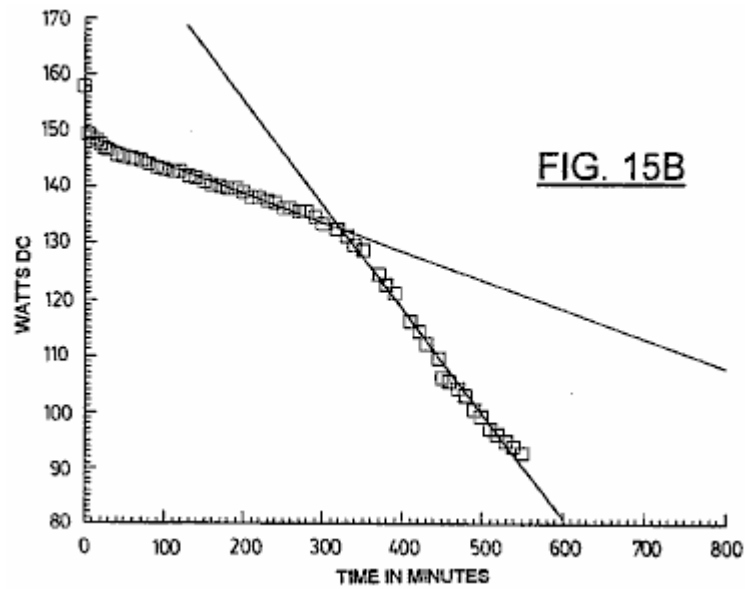
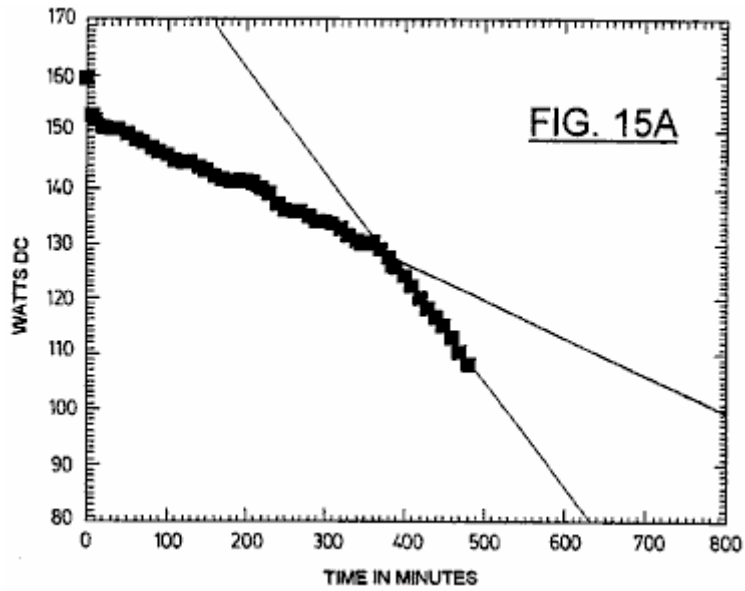

Fig.15A and **Fig.15B** show resistive voltage discharge curves for two separate lead-zero gel-cell packs utilised respectively as the drive and the charge packs; load resistances employed were 2083 ohms across the drive pack (Fig.15A) and 833 ohms across the charge pack (Fig.15B).

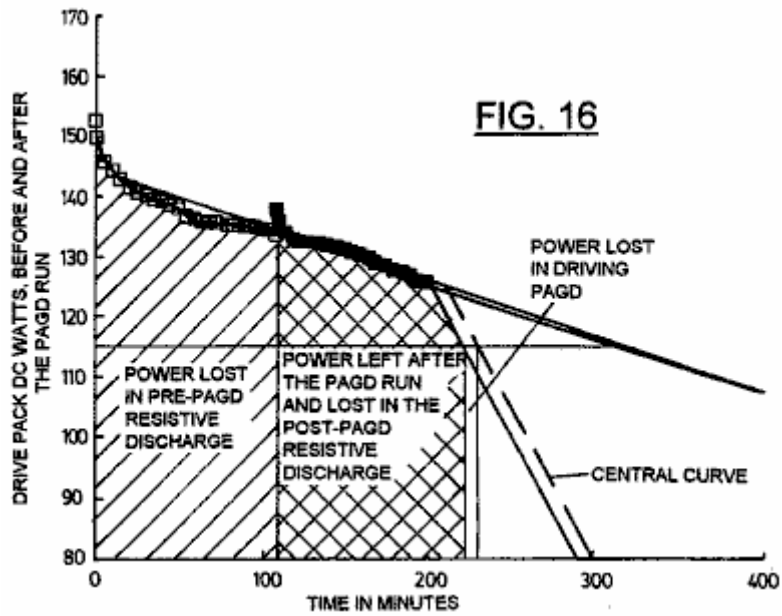

Fig.16 shows resistive discharge slopes for a drive pack before and after a very small expenditure of power in providing energy input to a PAGD run; $R = 2083$ ohms.

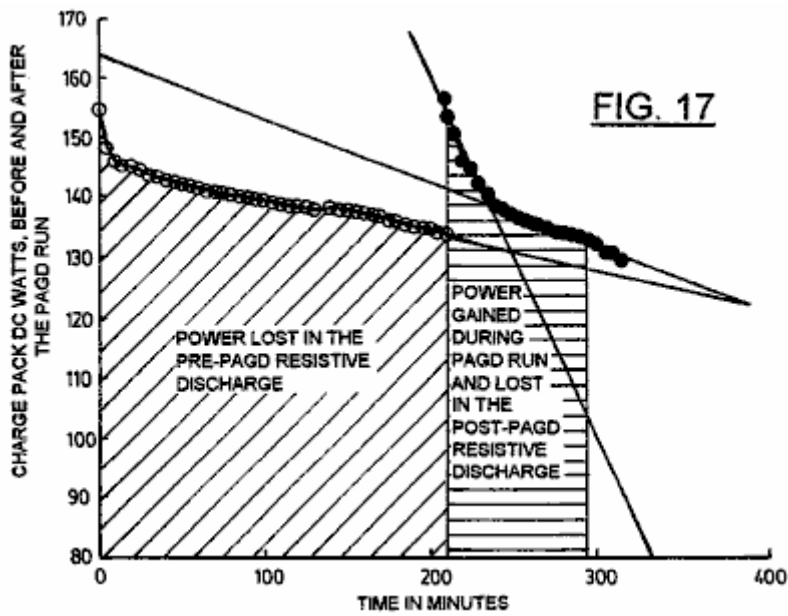

Fig.17 shows resistive discharge slopes for a charge pack before and after capturing energy from the collapse of PAGD pulses in the same test as Fig.15; $R = 833$ ohms.

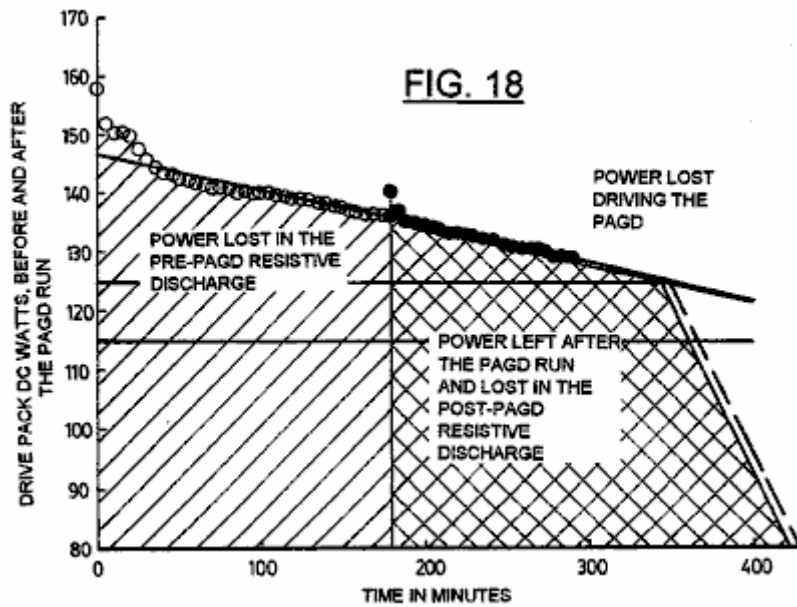

Fig.18 shows resistive discharge slopes for a drive pack before and after a very small expenditure of power in providing energy input to a PAGD run in a further experiment; $R = 2083$ ohms.

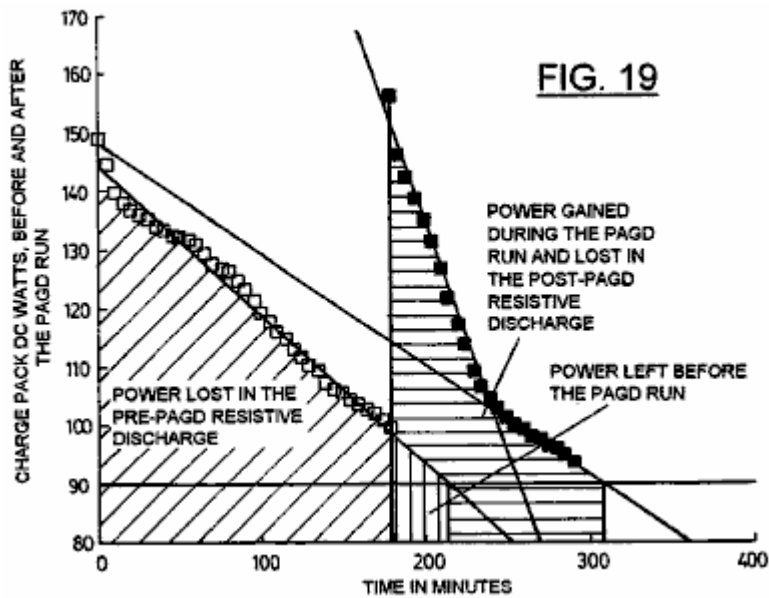

Fig.19 shows resistive discharge slopes for a charge pack before and after capturing energy from the PAGD run of Fig.18; $R = 833$ ohms.

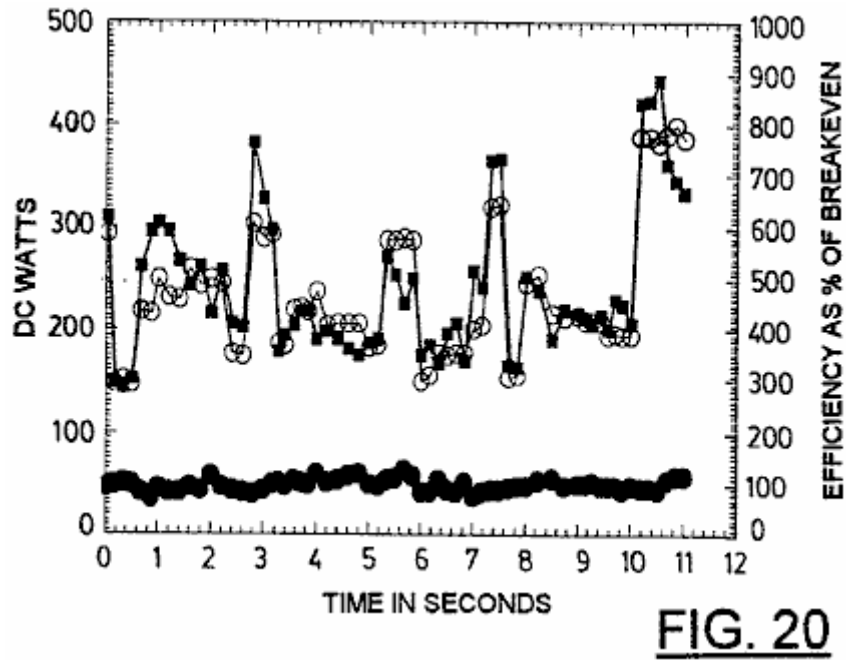

Fig.20 shows an example of operational measurements taken videographically during a 10 second period for both the power consumption of the drive pack (PAGD input) and the power production captured by the charge pack (PAGD output); the two values are also related by the expression of percent break-even efficiency.

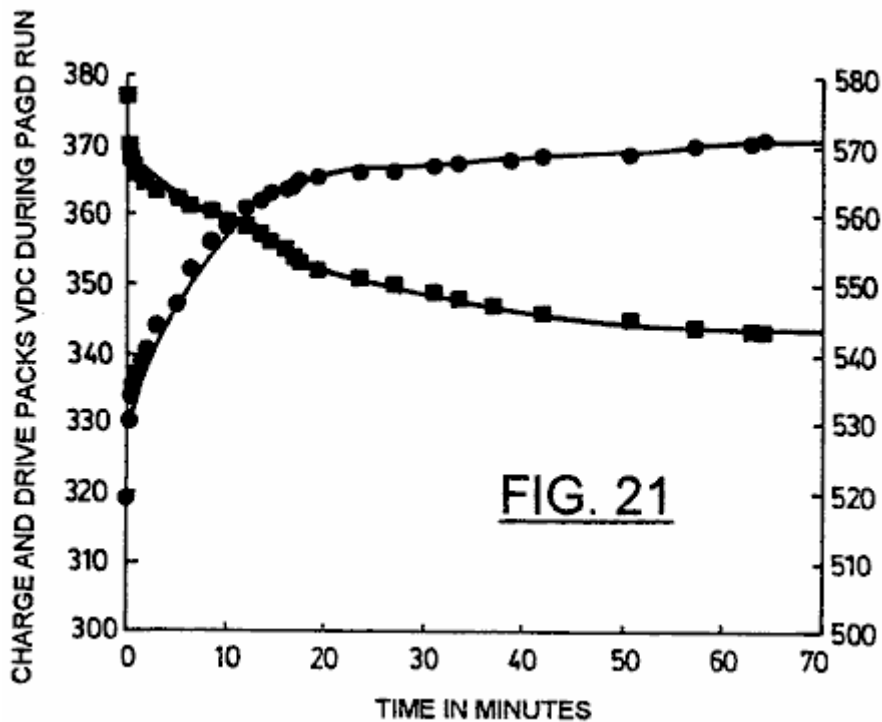

Fig.21 shows variation of PAGD loaded voltage of a drive pack (in squares) compared with the PAGD charging voltage of the charge pack (in circles), during more than 1 hour of continuous PAGD operation.

DESCRIPTION OF THE PREFERRED EMBODIMENTS

The basic PAGD function and the construction of discharge tubes specifically designed for PAGD operation are described in our corresponding co-pending applications Nos. 07/922,863 (the "863" application) and 07/961,531 (the "531" application). For purposes of the experiments described below four aluminium H34 plate devices (one with 64 and three with 128 cm² plate areas) and three aluminium (H200) plate devices (one with 64 and two with 128 cm² plate areas), with inter-electrode gap lengths of 3 cm to 5.5 cm, were utilised at the indicated vacua, under pump-down conditions and with either air or argon (ultra high purity, spectroscopic grade 99.9996% pure)

constituting the residual gas mixture. The pump-down conditions were as described in the "863" application. Some experiments were performed with the tubes under active evacuation, at steady-state conditions, while others utilised sealed devices enclosing the desired residual gas pressures.

The circuit designs utilised in the various experiments to be described are set out further below, and represent further developments and extensions of the circuits set forth in the "531" application.

Test equipment utilised was as follows:

An Edwards (trade mark) thermocouple gauge (TC-7) was employed for the determination of pressure down to 1 micron of mercury (0.001 Torr).

Banks of Beckman (trade mark) rms multimeters 225 and 330 (30 and 100 kHz bandwidths, respectively) were utilised for all current measurements.

Frequency meters capable of discriminating events up to 0.1 nanosecond apart, and having adjustable amplitude windows, were used. Direct analysis on a Tektronix (trade mark) dual-trace, storage scope (Model 549) was also carried out for both parameters.

Split-phase, single-phase and two-phase motors were employed, of the synchronous, induction and universal types, as previously described in the "531" application, in the accessory electromechanical arm that may be coupled to the power producing circuit described in the present application.

Large banks of 12 V, 6 Ah lead-acid gel cells (Sonnenschein (trade mark) A212/6S) were utilised either as power sources (designated as drive packs) or as accumulators of the energy (referred to as charge packs) captured by the test circuits. Charge packs made of rechargeable 9V NiCad or of nominally non-rechargeable C-Zn or alkaline batteries were also utilised.

PAGD emission areas were determined by metallographic examination of a series of craters produced by PAGDs in clean H34 cathodes, under a metallurgical Zeiss (trade mark) standard 18 microscope equipped with an epifluorescent condenser, very high power apochromatic objectives and a 100 W mercury lamp. For best results a focusable oblique source of light (12V halogen) was also added to the incident light.

Following our low and high applied current studies on PAGD production as set forth in the "863" application, we noticed that the AC rms value of the component associated with each abnormal glow discharge pulse varied non-linearly with the magnitude of the applied current. We originally noted the existence of a current induced shift of the entire PAGD region upward in the pressure scale: while the PAGD regime became more clearly defined as the applied constant DC was increased, the pressure required to observe the PAGD increased two to three orders of magnitude. In the course of these rarefaction studies we found that, at applied currents of 1mA or less, the rms value of the different AC waveforms associated with the consecutive regimes of the discharge (TRD --> NGDm --> AGD+PAGD) was, by more than half log, inferior to the value of the applied DC current, during the first two regimes (TRD and NGD) and reached a value equivalent to the applied current with the onset of spontaneous PAGD, at pressures < 0.1 Torr (see **Fig.1**); however, in the downward tail of the PAGD regime (down to 3×10^{-3} Torr), the AC rms current component of each PAGD again decreased to more than half log of the intensity of the applied DC value, in a manner proportional to the log of the decreasing pressure. In stark contrast, at high applied currents of about 500 mA, and aside from the high current-induced upward shift in pressure of the PAGD regime (to the point that the compression of the previous regimes on the pressure scale results in their suppressing, as was the case in the present example), the AC rms component associated with each pulse (see closed circles, **Fig.2**) is, from onset of the discharge at about 8 Torr, greater in magnitude than the value of the applied current (open circles, **Fig.2**). Under the conditions described, the distribution of the field current associated with each pulsed abnormal glow discharge approached (on a linear Y axis; not shown) an uni-modal gaussian distribution with the pressure peak at about 1 Torr, and a corresponding observed maximum of 7.5 times higher AC rms values than the applied DC values.

We have previously described in the "863" application how the PAGD frequency is affected by several factors, namely:

- the magnitude of the parallel discharge capacitance,
- the value of the negative pressure for the relevant vacuum PAGD range,
- the magnitude of the applied potential, the magnitude of the applied direct current,
- the inter-electrode gap distance and
- the area of the parallel plate electrodes.

In the "531" application we have also described how the wiring configuration (plate diode versus triode) affects the PAGD frequency by adding tungsten auto-electronic emissions from the axial electrode, to those emissions from

the plate. There are other factors which limit the PAGD regime of discharge and have also been discussed in the "863" application. The following data indicates their specific effect upon PAGD frequency.

In the data presented in Table 1, control of the frequency parameter for the circuit shown in **Fig.9** is by a ballast resistance **R1** within a specific range of interest (about 800-150 ohms, for Table 1 experimental conditions), and this in turn increases the applied current which, at "high current" values (i.e. >100 mA, as for Table 1 conditions), will drive the PAGD frequency up, as previously reported in the "863" application.

Table 2 shows the effect of the progressive displacement of a given frequency, chosen as 200 PPS, with the cumulative pulse count of the same device, in the plate diode configuration. This displacement of the same frequency (cf. group numbers 1-3 of Table 2) on to higher pressure regions is shown to be promoted by the alteration of the work function of the PAGD emitting cathode, such as this is caused by the cumulative pulse count and resultant crater formation on the electrode surface. After the first million pulses, the anode facing cathode surface is completely turned over by emission sites, and this corresponds well to the threshold crossed by group 2 of Table 2. Once the cathode surfaces are broken in, the rates shown in groups 3 and 4 of Table 2, tend to remain constant.

Originally we wondered whether this might be caused by the alteration of the electrostatic profile of the plasma sheaths at the periphery of the envelope, due to the mirroring deposits that result from the sputter of ions and trapped neutral atoms (from air gases or metallic vapour) associated with the auto-electronic emission mechanism (and from further emissions triggered in turn, by secondary ionic bombardment of the cathode with molecular species present in the plasma ball formed over the primary emission site). However, reversal of the plate polarity (firing the ex-anode as a crater-free cathode) for over a million counts, followed by re-reversal to the original polarity, the entire operation being performed in air as the residual gas substrate, led to the partial recovery of the original work function for as long as the test was run (1.5×10^4 pulses), as shown by a comparison of groups 2, 4 and 5, of Table 2. From a metallographic examination of the surfaces of plates used solely as anodes, we have also concluded that prolonged PAGD operation has the effect, not only of cleaning the anode surface from surface films and adsorbed gases, as ionic bombardment promoted by electromagnetic induction coils does, but it also does more: it polishes the target surface and smoothes it by a molecular erosive action. Observations of the surface of reversed cathodes, shows the same smoothing and polishing effects observed in exclusive anodes. Thus the recovery of the PAGD rates promoted by polarity reversal of the plates is not a function of the sputter-promoted mirroring deposits on the envelope wall, but a function of the actual work-function of the emitting cathode.

Another variable that interacts with the PAGD frequency is the molecular nature of the residual gas: Table 3 shows the differential frequency response of air with a halogen quencher, argon, for the same pulse generator employed in the tests of Table 2. It is apparent that argon obtains much higher rates of AGD pulsation for the same range of negative pressure, for the same "broken in" cathode, than does the air mixture. All these measurements were taken at cathode support-stem temperatures of 35⁰C.

Time of operation is also a variable affecting the frequency and operating characteristics of the cathode, as it becomes expressed by the passive heating of the cathode, an effect which is all the more pronounced at the higher pressures and at the higher frequencies examined. Utilising the triode circuit discussed in the next section, the pulse rate of a PAGD generator with 64 cm² plates can be seen (see **Fig.3**) to decrease, at a negative pressure of 0.8 Torr, from 41 PPS to the operating plateau of 6 PPS within 15 minutes of continuous operation, as the temperature of the cathode support increased from 19⁰C to about 44⁰C. As the temperature plateaus at about 51⁰C +/- 1⁰C., so does the pulse rate at 6 PPS, for the remaining 48 minutes of continuous operation.

However, in order to confirm this time-dependent heating effect and threshold, we also performed the same experiment, utilising the same circuit and the same negative air pressure, with twice as large a cathode area (128 cm², which should take nearly twice as long to heat), being operated for 18 one-minute long continuous periods equally spaced apart by 15 minutes of passive cooling, with the cathode stem always at 19.7⁰C to 21⁰C., room temperature at the start of each period. The results surprised us, inasmuch as they showed that for a larger area tube which takes longer to heat to the same temperatures at comparable rates of PAGD triggering, one could observe a much earlier frequency reduction (by half, within the first 5 minutes or periods of interrupted functioning) in the absence of any significant heating effect (< 1.5⁰C) of the cathode (see **Fig.4**). Repetition of these experiments has led us to conclude that, as shown in **Fig.5**, the variable responsible for this repeatedly observed reduction in the PAGD frequency, when the PAGD operation sequence is systematically interrupted, is the state of charge/discharge of the battery pack (the charge pack) at the output of the triode circuit in question: the PPM rates in **Fig.5** decrease rapidly with the steepest rate of charging of the charge pack and the fastest recovery rate of its open circuit voltage; above a given state of charge, when the open voltage of the charge pack climbs more slowly (> 340 V), in a log fashion, the PPM rate stabilises at its plateau values.

Confirmation of the importance of the charge pack in the PAGD function of the present circuitry here considered, comes from the fact that the size (the number of cells) and the intrinsic capacitance of the charge pack affect the PAGD frequency dramatically (see Table 4): increasing the charge pack size of 29 cells to 31, by 7% leads to a 10-fold reduction in frequency; further increases in the number of charge pack cells extinguishes the phenomenon. On the upper end of the scale, this effect appears to be tied in to restrictions that it places on the ability of the larger charge packs to accept the discharge power output once the charge pack voltage exceeds the PAGD amplitude potential. All of these measurements were conducted with the same 128 cm² plate PAGD generator, at a pressure of 0.8 Torr and in the triode configuration (see **Fig.9**).

Other factors can also affect the frequency: the motion of external permanent magnetic fields oriented longitudinally with the inter-electrode gap, external pulsed or alternating magnetic fields, external electrostatic or electromagnetic fields, specific connections of the earth ground, and the presence of a parallel capacitive, capacitive-inductive or self-inductive arm in the circuit, such as we have described for our electromechanical PAGD transduction method as described in the "531" application.

Analysis of the modulation of PAGD amplitude is simpler than that of its frequency, because fewer factors affect this parameter:

- (1) magnitude of the applied potential,
- (2) inter-electrode gap distance and
- (3) the negative pressure, as shown in the "863" application, for "low" applied currents.

As the magnitude of the applied potential itself is limited by the gap and the pressure, to the desired conditions of breakdown, the important control parameter for the PAGD amplitude is the pressure factor. This is shown in **Fig.6** and **Fig.7**, respectively for "low" (5 mA) and "high" (about 500 mA) applied currents and for the same plate diode configuration of a H34 Al 128 cm² plate PAGD generator (5 cm gap), in the simple circuit described in the "863" application; it is apparent that both positive and negative components of the amplitude of these pulses in the oscillograph, are a function of the pressure, but the maximum cut-off limit of our equipment, for the negative component (at 240 volts for the "low" current experiment and at 120 volts for the "high" current), precluded us from measuring the peak negative voltage of these pulses.

However, rms measurements of the pulse amplitude at the plates and DC measurements at the circuit output to the charge pack indicate that the negative component increases with decreasing pressure to a maximum, for a given arrangement of potential and gap distance; no pressure-dependent bell shape variation of the pulse amplitude, as that seen for the positive component at "high" applied currents (**Fig.7**) is observed with the negative amplitude component. For the typical range of 0.8 to 0.5 Torr, the rms value for pulse amplitude varies from 320 to 480 volts, for a 5.5 cm gap distance and applied DC voltages of 540 to 580 volts. PAGD amplitude is a critical factor for the design of the proper size of the charge pack to be utilised in the optimal circuit.

The development of the circuits to be described stemmed from fundamental alterations to the principles implicit in our previous methods of electromechanical transduction of AGD plasma pulses as described in the "531" application. Whereas this electromechanical coupling (capacitive and self-inductive), utilised directly, energises the AGD pulses inverted from the DC input by the vacuum generator, the purpose of the development that led to the presently described experiments was to capture efficiently, in the simplest of ways, most of the pulse energy in a closed circuit, so that power measurements for the energy transduction efficiency of the observed endogenous pulsation could be carried out. Ideally, comparative DC power measurements would be performed at both the input and output of the system, taking into account the losses generated across the components; this would overcome the measurement problems posed by the myriad of transformations implicit in the variable frequency, amplitude, crest factor and duty-cycle values of the PAGD regime, and necessitated some form of rectification of the inverted tube output.

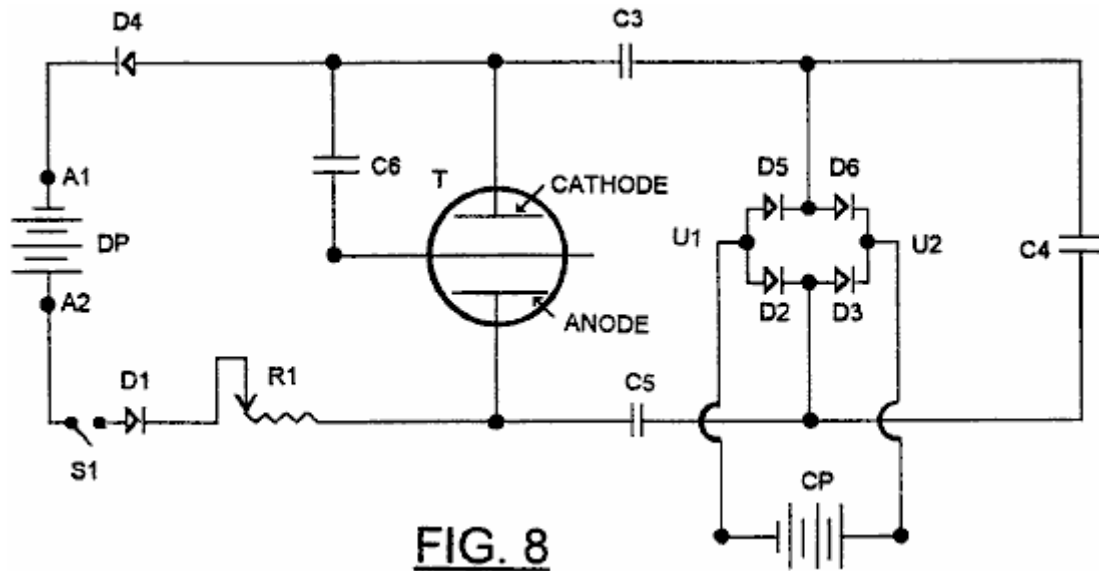

FIG. 8

From the start our objective was to do so as simply as possible. Early circuits utilising half-wave rectification methods coupled in series to a capacitive arm (for DC isolation of the two battery packs), with the charge pack also placed in series, showed marginal recoveries of the energy spent at the PAGD generator input. Attempts at inserting a polar full-wave rectification bridge led, as shown in **Fig.8**, to the splitting of the capacitor into capacitors **C3** and **C5**, at the rectification bridge input, and capacitor **C4** in series with both capacitors, all three being in a series string in parallel with the PAGD generator. Under these conditions a DC motor/generator could be run continuously in the same direction at the transversal output (**U1** and **U2**) of the bridge; but if this inductive load was replaced with a battery pack CP (charge recovery pack), either the parallel capacitor **C4** had to remain in the circuit, for the diode configuration or, less desirably, a further capacitor **C6** could replace **C4** and connect one electrode, preferably the cathode **C**, to the axial member of the discharge tube **T**, thus resulting in a first triode configuration as actually shown in **Fig.8**. Energy recovery efficiencies of the order of 15% to 60% were obtained utilising **C6** in this manner, but measurements of the potential and currents present at the output from the rectifier bridge were substantially lower than those obtained using optimal values of **C4**. Effectively, under these conditions, much of the power output from the tube was never captured by the output circuit formed by the second, right hand arm of the system and, being prevented from returning as counter-currents to the drive pack **DP** by diodes **D1** and **D4**, was dissipated and absorbed by the inter-electrode plasma, electrode heating and parasitic oscillations.

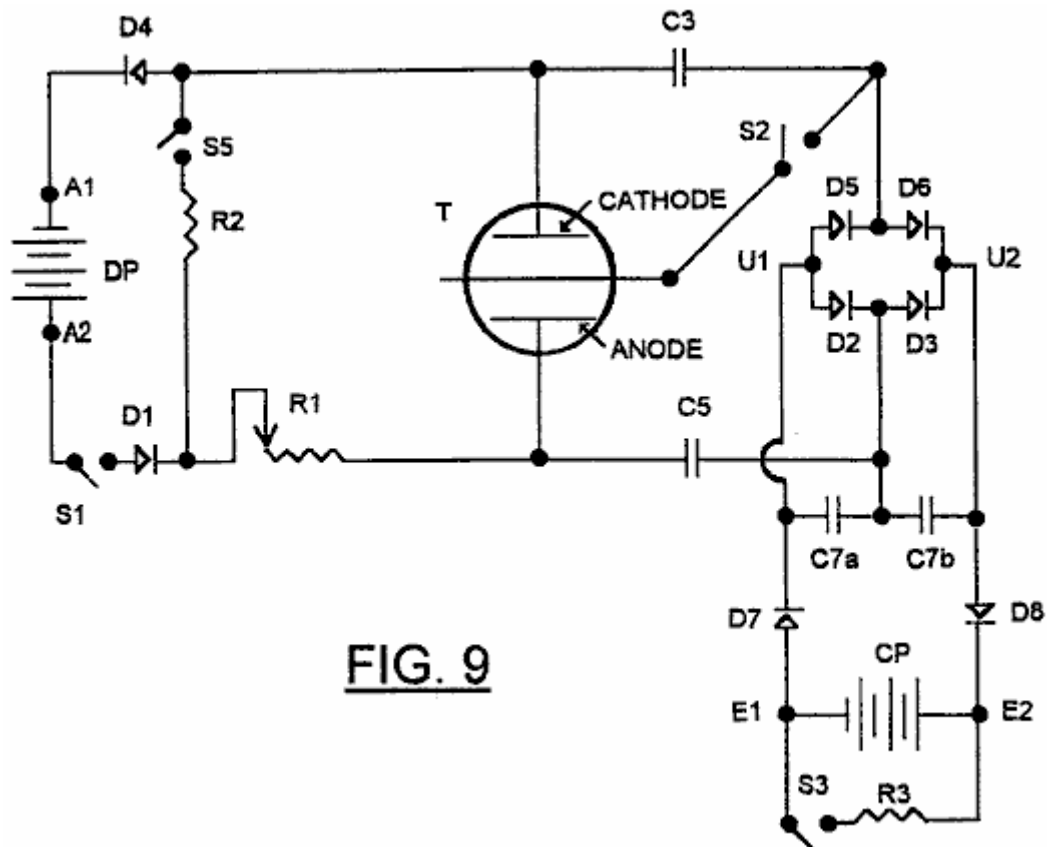

FIG. 9

Solutions to this problem were explored using the circuit shown in **Fig.9**, which still maintains the necessary communication link for the quasi-sinusoidal oscillation of the capacitively stored charges at the input and outputs of the rectification bridge, but integrated the functions of capacitor **C4** into the single rectification circuit, in the form of an asymmetric capacitive bridge **C7a** and **C7b** placed transversally to the capacitive bridge formed by **C3** and **C5** and in parallel with the charge pack **CP** at the output from the rectification bridge **D5, D6, D2, D3**.

This second capacitive bridge is so disposed as to have its centre point connected to the anode **A** through capacitor **C5**. If the axial member of the Tube **T** were to connect to the junction of **D2** and **D3** instead of at the junction **D5-D6**, the function of bridge **C7a** and **C7b** would be connected to the cathode **C** through capacitor **C3**. The capacitive bridge is insulated from the charge pack whose voltage it stabilises, by rectifiers **D7** and **D8**, which also prevent leakage of charge across **C7a** and **C7b**.

The anode and cathode oscillations generated by the electrostatic charge transduction through **C3** and **C5** into the poles of the charge pack are trapped by the transversal transduction of the **C7** bridge, at the outputs from the rectification bridge, of which the oscillation has to become split between the bridge inputs into half-waves, for electrostatic transduction and full wave rectification to occur. In fact, under these conditions, removal of the **C7** bridge will suppress the PAGD phenomenon, unless other circuit variables are also altered. The transversal bridge is thus an essential piece of this novel circuit. Variations in the circuit as shown in **Fig.10** were then studied, the first two being selectable utilising switch **S2** (**Fig.9**).

The presence of the capacitive bridge effectively reduces the dynamic impedance of the charge pack **CP** so that the output circuit approximates to a characteristic in which it presents a very high impedance to the tube **T** at potentials below a certain level, and a very low impedance at potentials above that level.

With this modified circuit, more effective recovery of the energy produced by collapse of the PAGD pulses is possible, with more effective isolation from the input circuit utilised to trigger the pulses. Under these conditions, the energy captured by this circuit at the output, is not directly related to that utilised in triggering the pulses from the input. The attainment of this condition critically depends on the large capacitance of the transversal bridge being able to transfer the output energy from the tube **T** into the charge pack **CP**. Under these conditions, we have found, as will be shown below, that the large peak pulse currents released by collapse of the PAGD pulses released more energy than is used to trigger them, and these findings appeared to tally with other observations (abnormal volt-ampere characteristics and anomalous pulse currents, etc.) associated with the anomalous cathode reaction forces that accompany the auto-electronic emission-triggered PAGD regime. Experiments so far indicate that the power output can be increased proportionately to the series value of **C3, C5** and the two identical **C7** capacitors.

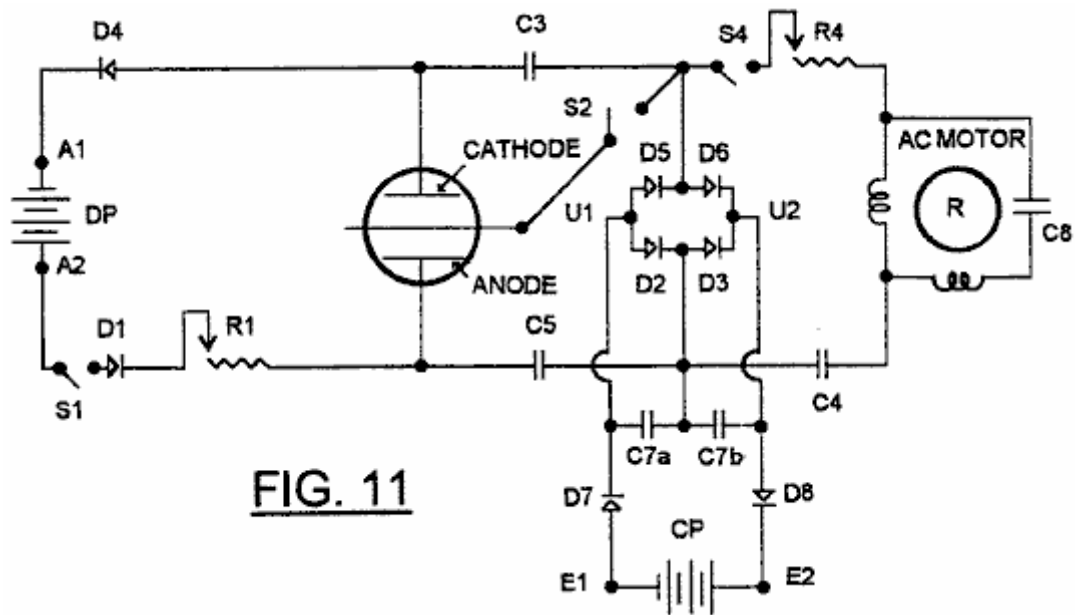

FIG. 11

The circuit of **Fig.10** can be integrated with a circuit such as that disclosed in the "863" application as shown in **Fig.11**, in which a part of the energy recovered can be shunted by the switch **S4** into an induction motor **M1** having rotor **R**, to a degree determined by the adjustment of potentiometer **R4** and the value selected for **C4**.

The circuit of **Fig.11** can be further developed as exemplified in **Fig.12** to include configurations which provide switching permitting interchange of the functions of charge packs and the drive packs, it being borne in mind that the nominal potential of the drive pack must be substantially higher than that of the charge pack, the former needing to exceed the breakdown potential of the tube at the beginning of a PAGD cycle, and the latter to be less than the extinction potential.

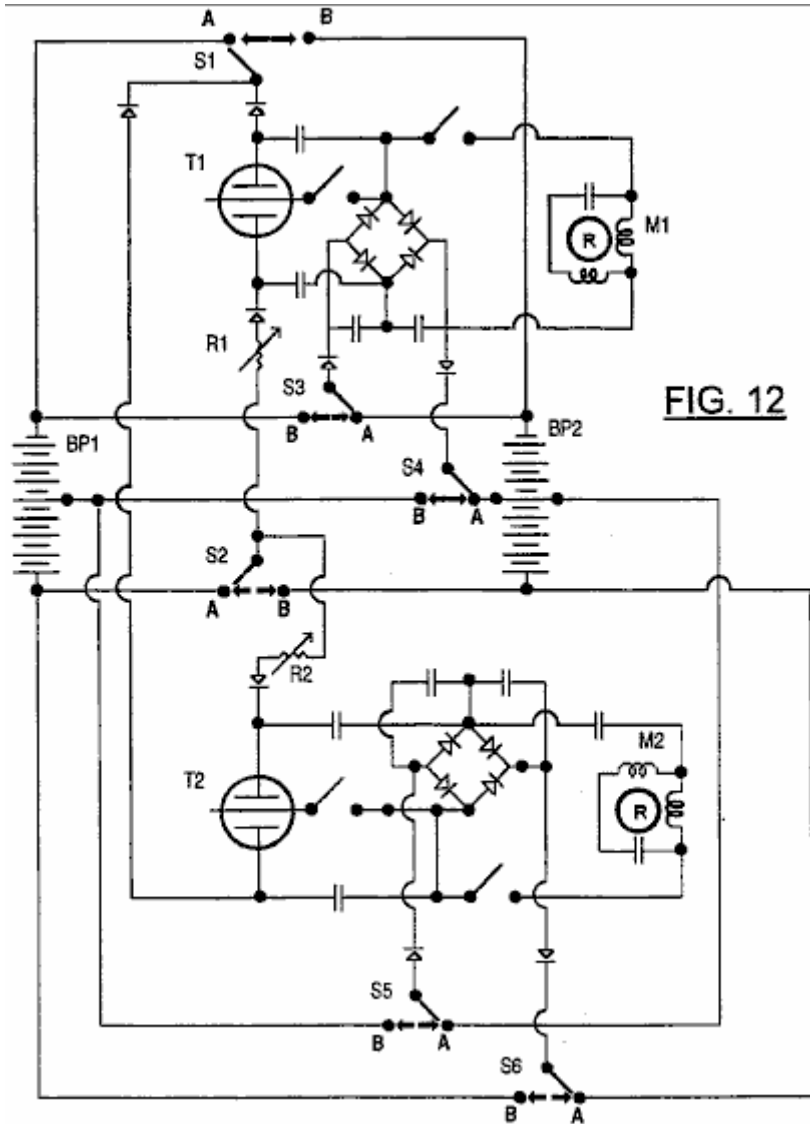

FIG. 12

Fig.12 essentially represents a duplication of the circuit of **Fig.11**, the two circuits however sharing two identical battery packs **BP1** and **BP2**, and being provided with a six pole two way switch, the contact sets of which are identified as **S1, S2, S3, S4, S5** and **S6**. When the contacts are in position **A** as shown, battery pack **BP1** acts as a drive pack for both circuits, with the upper half (as shown) of the battery pack **BP2** forming the charge pack for the upper circuit, and the lower half forming the charge pack for the lower circuit. When the pack **BP1** is at least partially discharged, the switch is thrown so that contacts move to position **B**, which reverses the function of the battery packs thus allowing extended operation of the motors in each circuit each time the switch is thrown.

Based on the manufacturer's data, and using current values within the range of our experimentation as discussed in the next sections, an optimal discharge cycle for a fully charged 6.0 AHr battery pack at 0.300 A draw is 20 hours, as claimed by the manufacturer, and this corresponds to a cycling between 100% (12.83 V/cell open circuit and load start voltage) and < 1% (10.3 V/cell load voltage) of the battery's absolute charge capacity. Even though the discharge mechanism is a time cumulative process with a log function, the discharge can, within 4 to 5 hour time segments (or periods with 20%-25% of the full range), be regarded as practically linear with time. This trait, or linearisation of the discharge slope, becomes more marked with advancing age and decreasing absolute storage capacity of the cells.

The proportionality between open circuit voltage and the percentage of residual relative capacity for these cells when new (uncycled and not yet aged) is uniform over 98% of the permissible charge capacity withdrawal. In practice this translates into a slope that becomes steeper with time, while the absolute storage capacity diminishes. In turn, this decreasing absolute capacity of the cells results in shorter load discharge times and their further linearisation.

A circuit in general accordance with **Fig.9**, employed in the studies reported in this and the following sections, utilises a drive pack of 46 12 V Lead acid gel-cells each with a 6.0 Ah rating, and a charge pack with 28 or 29 12 V identical cells. The charge pack was cycled anywhere from 11.2 V to 12.8 V/cell (open circuit voltages), within the proportional region of the relative capacity slope, to yield a capacity increment in the order of 50% (e.g. from

20% to 70%), anywhere within the range of 2% to 100% of its total charge capacity, assumed for now as invariant. The charging process, hereinafter referred to as a PAGD run, took about 20-30 minutes under optimal conditions. The drive pack typically consumed, in the same period of time, 4% to 11% of its initial total capacity, its open circuit voltage typically falling 0.1 V to 0.2 V per cell after a PAGD run, within the open circuit range of 12.8 V/cell (100% relative capacity) and 11.2 V/cell (about 2%). At the 100% capacity benchmark, the drive pack would theoretically have $20 \text{ h} \times 46 \text{ cells} \times 12.83 \text{ V/cell} \times 0.3 \text{ A} = 3.5 \text{ kWh}$, and the charge pack, for example, $20 \text{ h} \times 29 \times 12.83 \text{ V/cell} \times 0.3 \text{ A} = 2.2 \text{ kWh}$. Since the capacity per cell is linear with the open circuit voltage within the proportional range, as claimed by the manufacturer, we projected the open circuit voltage intercepts on the manufacturer's proportional curve in order to determine the residual percentage of the total relative capacity and the standard hours of operation left, from any experimental open circuit voltage measurements.

Three pulse generators (one 64 cm^2 and two 128 cm^2 plate areas) were employed in these studies; they were operated in PAGD runs at 1-120 pulse/second rates, within a negative pressure range of 0.2 to 0.8 Torr and with applied direct currents of 0.2 to 0.6 A.

Both drive and charge packs utilised cells which were bought new at the same time and had initial charge values of 12.4 to 12.55 V/cell (open circuit). These batteries are capable of energy densities of 33-35 WHr/Kg. However, the experiments shown in Table 5 are selected from a series that spanned nearly 12 months, beginning 6 months after purchase; hence, loss of absolute storage capacity by the batteries had occurred in the intervening time, as a function of both age and charge/discharge cycle life.

Measurements of the open voltage of either drive (D) or charge (C) (see column 2, Table 5) packs for 8 separate experiments, all utilising the triode configuration, were performed before (b) and after (a) a PAGD run (see columns 3 and 4), at either 15 or 30 minutes (see column 26) of the open circuit voltage relaxation after a PAGD run was terminated. Corresponding open circuit voltages per cell are shown in column 5, and the percentages of the predicted total relative charge capacity resulting from the intercepts on the manufacturer's proportional curve are shown in column 6, Table 5. Equivalent maxima for the theoretical hours of operation left are shown in column 7, the percentage change in relative capacity arising as a consequence of either charge pack charge capture (capacity gained) or of drive pack output (capacity lost) is shown in column 8. Translating the intercepts into power units yields the values shown in column 9, Table 5, for total kWh left in each pack before and after PAGD production, those shown in column 10 for the actual power gained and lost during the periods of operation (presented in column 12) and those shown in column 13 for the power predicted to be gained or lost per hour of PAGD production.

On the basis of the experimental open voltage values and their intercepts, the predicted net kWh values per hour of PAGD energy production (after deduction of measured losses) and the corresponding experimental break-even efficiencies (where breakeven = 100%) are presented, respectively, in columns 14 and 15. The PAGD frequency per second is shown in column 11; the number of 12 V cells, in column 16; the tube ID, in column 17; the cathode (and anode) area (s), in column 18; the plate material, in column 19; the input ballast utilised (R1, FIG. 9), in column 20; the size of each capacitor (C3 or C5) of the tube output bridge, in column 21; the size of each capacitor (C7a or C7b) of the transversal capacitive bridge, in column 22; the status of **S4** and thus, of the parallel and auxiliary electromechanical arm (see **Fig.11**), in column 23; the negative air pressure in column 24; the gap distance between the plates, in column 25; and columns 27,28 and 29, show the status of the elements of the switched on parallel electromechanical arm of the circuit--the parallel **C4** capacitor, the motor input resistor **R4** and the motor revolutions per minute (measured stroboscopically), respectively.

From these figures of Table 5, and utilising the data for the two first examples shown, we calculated the predicted performance of the system based on the open voltage measurements. In the first example, where the system was run continuously without interruption, the charge pack increased the percentage of its total capacity by 43% (a two-fold increase in capacity) and, during the same period, the driver pack decreased the percentage of its total capacity by 7% (an approximately 10% decrease in capacity relative to the percentage of residual total capacity at the start, i.e. 77%) (cp. columns 6 and 8, Table 5). Subtracting the predicted initial total energy (0.835 kWh) available to the charge pack before the experimental run (first line of column 9, Table 5) from the predicted total energy (1.823 kWh, second line of column 9) available to the charge pack after the PAGD charge run, gives us the total energy gained by the charge pack: 0.988 kWh (column 10) in 21.5 minutes (column 12) of continuous PAGD performance.

Conversely, subtracting the predicted final total energy (2.4 kWh) available to the driver after the experimental run (fourth line of column 9, Table 5) from the predicted total energy (2.66 kWh, third line) available to the driver before the PAGD charge run, gives us the total energy lost by the drive pack: 0.26 kWh in 21.5 minutes. If we divide the total available energy gained by the charge pack, by the total energy lost by the drive pack, we obtain a surplus factor of 3.9., or 388% of the break-even point (column 15). The same values result from dividing the charge pack % of total capacity gain by the drive pack % of total capacity lost, and then down-scaling this value by multiplying it by the typical scale factor for the two packs, $29 / 46 = 0.63$ times.

In an analogous fashion, we analysed the results for the second example shown in Table 5. Here, the charger increased the percentage of its total capacity by 45.5% (a 22.75 fold increase in estimated total relative capacity) and, during the same period, the driver decreased the percentage of its predicted total capacity by 7% (about a 17.5% decrease in capacity relative to the percentage of residual total capacity at the start, i.e. 40%). By dividing the predicted total available energy gained by the charge pack (0.962 kWh/18 minutes) by the expected total energy lost by the driver pack (0.246 kWh/18 minutes) we obtain a surplus factor of 3.9 times, or 391% of the break-even point. This corresponds to an interrupted, total sequential run of 18 minutes, each minute-long run being separated by a cooling and voltage relaxation period of 15 minutes before the next run is carried out, at an average PAGD frequency of 61 PPS.

Analysis of the remaining results illustrates how a number of PAGD controlling parameters interact to determine conditions for effective maintenance of a PAGD regime. The lower gain and higher loss per unit time registered for the third run of Table 5, which results in the lower break-even efficiency of 230% and a smaller net power production rate than before (power estimates of 1.396 kWh/h of PAGD operation vs 2.387 kWh/h, for the second run, Table 5) illustrate, for example, the combined effect of lowering the pressure (0.8 to 0.7 Torr) and running the PAGD continuously (the heating effect), both of which depress the PAGD frequency. The fourth run of Table 5 identifies the continuous performance of a "broken in" softer grade of aluminium (column 19), having a lower work-function (as determined from the higher PAGD frequency spectrum) than the harder H34 plates of the previous examples, and shows that, despite the series value of the total capacitance being higher (5,333 mF vs 4,030 mF for runs one through three), and despite the higher vacuum (0.2 Torr), the lower work-function results in a higher frequency; however, even though this run registers a predicted higher break-even efficiency (310%) than the previous experiments, these conditions result in a 4 / 5-fold lower estimate of net power produced, when compared to the previous three PAGD runs.

PAGD runs 5 and 6, Table 5, illustrate the effect of switching on the auxiliary electromechanical arm of the circuit shown in **Fig.11**. Increasing the amount of charge capacitatively shunted into the electromechanical arm by higher **C4** values (column 27), and increasing the current that feeds the squirrel cage induction motor utilised by lowering **R4** (column 28), results in a power capture by the charge pack that registers an energy loss (predicted to be 96% efficient, falling short 4% of break-even recovery), as most of the tube output power is spent in the electromechanical arm and its motor effect. Furthermore, under the conditions of maximum electromechanical action, the drain imposed on the drive pack becomes considerable (see loss in columns 10 and 13), even if the **C3** and **C5** values are reduced, column 21, Table 5). These runs also illustrate how the motor appears to function as an electrical induction generator having rpm values much higher than the synchronous values prescribed by the frequency of the PAGD (column 29, Table 5).

The extremely large break-even efficiency of PAGD run 5, Table 5, indicates that with selected values of **C4** and **R4**, it is possible to operate the motor in the auxiliary arm and still accumulate excess energy from the PAGD production in the charge pack.

Runs 7 and 8 illustrate results obtained for 64 cm² plates, and a shorter inter-electrode gap distance, for two pressures (0.8 and 0.5 Torr), the device being open to a rotary pump manifold in the first instance and sealed from the pump, in the second case. Despite the lower vacuum, the higher pulse frequency (32 vs 5 PPS) and break-even efficiency (906% vs 289%) registered by run 8 when compared to run 7, are a consequence of the method of run 8, which was interrupted systematically by 5 passive cooling periods, as in the case of run 2, whereas run 7 was continuous. This again resulted in higher average PAGD frequencies (at lower pressures), a predicted two-fold greater gain and a predicted two-fold smaller loss (columns 13 and 14) for run 8.

Fig.13 shows curves representing the slopes of the open circuit relaxation voltages, which are linear with the log of time elapsed from cessation of discharge, for both drive and charge packs, in the same run 8 set out in Table 5. The experiment in its entirety consisted of preliminary resistor-loaded measurement discharges and their corresponding open circuit voltages from the moment of cessation of the resistive discharge (illustrated, respectively, by the open squares of DPT1 for drive pack relaxation time 1, and by the open circles of CPT1 for charge pack relaxation time 1), followed by their relaxation rates in the wake of the PAGD production (the hatched squares of DPT2 for drive pack relaxation time 2, and the hatched circles of CPT2 for charge pack relaxation time 2), and finally, by the relaxation rates from the final resistor-loaded measurement discharges (the black squares of DPT3 for drive pack relaxation time 3, and the black circles of CPT3 for charge pack relaxation time 3). Discharge resistances were 833 ohms for the charge pack, and 2083 ohms for the drive pack in all cases, corresponding to resistors **R3** and **R2**, respectively, of **Fig.9**. This methodology will be examined in greater detail below. It is apparent that, after every load period, be this resistive (CPT1, DPT1, CPT3 and DPT3) or due to PAGD operation (DPT2), the relaxation slope is positive; as shown from slopes CPT1 and DPT1, the log time proportionality of the open circuit voltage relaxation, under these conditions, tends to plateau after about 30 minutes. The exception to this general behaviour lies in the voltage relaxation slope CPT2, which is negative and

reflects the charge accumulation occurring in the charge pack and obtained by capture of energy produced during PAGD operation, triggered by the energy drawn from the drive pack during load time 2.

As a first approximation of electrical power generated and consumed by the energy conversion system of the invention, the previous open circuit voltage method is of significance in showing the basic trends involved in interaction of the operating parameters. However, in all likelihood, it overestimates the actual values of electrical power consumed and generated, for a variety of reasons. First, it assumes that the relative capacity scale of the batteries in the drive and charge packs is an absolute charge capacity scale with an invariant maximal charge retention, which it is not; in fact, the absolute charge capacity is itself a variable subject to several factors, such as the cycle life, overcharging or undercharged conditions, cell age, residual memory and the rate of charge and discharge. Hence, the inference of a uniform time scale on the basis of the open circuit voltage/capacity intercepts may not be warranted. Finally, it does not integrate the open voltage decrease over time, and utilises the specification load current as the average current over time.

In order to obviate these problems, we resorted to a variety of other measurement methods. First, we proceeded to compare the closed circuit, preliminary, resistive-load discharge measurements for either charge or drive pack, under conditions of negligible loss of power, as these measurements were statistical means ($n = 9$) taken, at equal intervals, during the first 90 seconds of the load discharge, and obtained both just before the PAGD production runs (but separated from each PAGD run by an open circuit voltage relaxation of 30 minutes) and just after the runs (but equally separated by a relaxation of 30 minutes). As an example of the data generated by such an approach, **Fig.14** illustrates the shift of the slopes indicating marginal power loss for the drive pack (from the closed squares to the open squares) and those indicating gain of power for the charge pack (from the open circles to the closed circles), in actual total load power values.

Integration of these power measurements over the projected load discharge time, taken from the family of curves generated on the basis of the manufacturer's load voltage over discharge time specifications, led to a direct comparison of the new values, as shown in Table 6, with the values presented in Table 5, for the first three instances introduced. All values of Table 6 were obtained by resistive measurements of power that entailed a negligible power loss. Table 6 confirms the fundamental equivalence of runs 1 through 3, as already seen from their corresponding analysis using the open voltage method (see runs 1 to 3, Table 5). This new power estimation method also confirms the lower loss encountered in run 2 utilising interrupted PAGD operation. While the break-even efficiencies sensibly doubled using this method, the estimates of actual electrical power consumption recovery decreased by a 2 to 3-fold factor. Thus this direct load voltage/amperage measurement method of estimating actual power losses or gains, is a check upon the open voltage method previously utilised.

Direct, instantaneous measurements of the voltage and current characteristics of the PAGD production and capture phenomena being discussed, were also performed during PAGD runs for diverse sets of conditions, including all those described in the two previous sections. In Table 7 we show these results for two PAGD generators having an identical electrode area (128 cm^2) and connected to electrical energy capture circuits of three separate configurations as set forth in **Fig.10A**, **Fig.10B** and **Fig.10C** and column 2, Table 7. In the configuration of **Fig.10C**, or double diode configuration, both electrode plates act as cathodes and the axial member as the anode collector (experiments 1-4, for the H220 device and 13-14, Table 7, for the H34 device). In the configuration of **Fig.10B**, or triode configuration, one plate acts as the cathode, the axial member as an auxiliary cathode and the other plate as a collector (experiments 5-9, Table 7). In the configuration of **Fig.10A** or single (plate to plate) diode configuration, the axial member is disconnected, and the polarity of the plates remain as in the triode configuration (experiments 10-12). All measurements were taken after 1 minute of PAGD operation of the devices, which were, at the start of each run, at room temperature. All cathodes had been previously broken in with $> 2 \times 10^6$ AGD pulses. The open circuit voltage of the charge pack was, for all cases, at 359 to 365 volts, before each test. The direct measurements of the PAGD input and output DC voltages and currents were obtained as statistical means of 10 second long measurements, and at no time did the standard error of the plate voltage mean exceed 35 volts.

The air pressure within the tube during these tests is shown in column 3, Table 7, the drive pack DC voltage (X), in column 5, the DC voltage across the plates (Y), in column 6, the drive pack output current (PAGD input current), in column 7, and the drive pack total watts output is shown in column 8. Columns 9 and 10 show the PAGD voltage ($\text{PAGD } V = (X-Y) / I_{av}$) and the value of the PAGD extinction potential in V/cm. The recovery coordinates (i.e. the PAGD output energy) found at the **U1-U2** output (**Fig.9**), are shown in columns 11 to 13, as the charge pack's E1-E2 input DC voltage, amperage and power watts, respectively. The calculated resistance of the entire circuit is given in column 14, the registered PAGD frequencies in column 16, and running conditions in columns 17 to 18. The break-even efficiency obtained by direct comparison of the electrical power figures for the drive and charge packs, respectively, is given in column 15. This assumes, for purposes of a generalisation of power production rates over time, that the quasi-instantaneous, direct measurements here obtained can be translated to outputs obtained per unit time, and thus into direct Watt-hour measurements.

Data from runs 1 through 4 demonstrate that, at these PAGD frequencies, there is no difference between using fast switching (32 nanoseconds) MUR 860 diodes, or regular 40HFR-120 silicon diodes, in the rectification bridge of the electrical energy capture circuit, and that the PAGD frequency varies as a function of decreasing air pressure.

Runs 5 to 14 show that, in general, for the same tube, the single and double diode configurations are the most efficient, for the same pressure, the diode configuration typically yields some 1.5 to 2 times larger break-even efficiencies (cp runs 10-11 and 13-14, with runs 5-9, Table 7). The largest accumulations of power are also registered in the diode mode(s). This trend appears to be a function of the much lower cathodic work-function of the aluminium plates, than of the tungsten of the axial member utilised as an auxiliary cathode in the triode configuration. A feature of the data from these 14 different runs is the consistent excess power outputs (column 15, Table 7) and their narrower range (218 to 563%), when compared to those observed with the previous two methods of experimental analysis.

Run 12, Table 7, shows that the switching on of the electromechanical arm can be performed without entailing a power loss in the PAGD capture circuit, as previously found for run 5, Table 5, utilising the open circuit voltage method. In fact, with $C_4 = 8$ microfarads and $R_4 = 500$ ohms, the AC induction motor behaves as an electrical flywheel (e.g. 2800-3000 rpm for 10 PPS inputs), while the electrical energy capture circuit still registers a sizeable excess electrical power production (compare runs 11 and 12, Table 7). Runs 13 and 14 illustrate how the charge pack's state of charge and its inherent capacitance affects both the PAGD frequency and the power producing efficiency of the entire system: as the charge pack is reduced from 29 to 19 cells, the PAGD generator adjusts by reducing its frequency logarithmically and, while the charge pack input current is greater than before, the drive pack loss becomes still larger and the break-even efficiency much lower (by $>1/2$, from 563% to 228%). This is because the circuit must translate the naturally larger PAGD amplitude into a larger surplus of output current, and in this process becomes less efficient.

If the first measurement method employed (the open circuit method) had to make too many theoretical assumptions about the system's performance under load conditions and hence about its effective charge capacity, the second approach still had to suppose an invariant discharge time and thus an invariant absolute charge capacity on the part of the battery systems (charge packs) employed for capture which it approximated by an operation of integral calculus. With the third method described above, theoretical assumptions were avoided except that, in these measurements, the actual performance of a given battery in terms of time, time of delivery and time of capture, was also ignored; no account is taken of the time-dependent modulation of the PAGD frequency, as effected by certain of the parameters analysed, namely the charge pack state of charge, the method of sequencing the PAGD runs (continuous vs interrupted) and its concomitant heating effects, and the state of charge (load voltage and current capacity) of the drive pack. A simple, non-negligible, resistive measurement of power lost by the drive pack, and an identically non-negligible measurement of the power gained by the charge pack, for the same experiment and the same singular time of PAGD production, were performed repeatedly to corroborate the previous three approaches. For this purpose, all experiments were designed as a continuous series of sequential phases:

- 1) Before a PAGD run, a resistive discharge was measured across either pack over periods of 1 to 3 hours (utilising the DP and CP resistances previously reported in the open voltage section) and followed by a 15 to 30 minute open circuit voltage relaxation;
- 2) Then, the PAGD runs were performed, either continuously or as interrupted, composite sequences, and the corresponding open circuit relaxation voltage(s) were measured, after the cessation of the integral PAGD run;
- 3) Finally, resistive discharge measurements, obtained under identical conditions to those recorded before the PAGD run, were carried out for either pack, followed by concomitant battery voltage relaxation rate measurements.

Under these experimental conditions, exact power measurements could be taken from an analysis of the actual battery discharge curves before and after the PAGD run. Based on a comparison of the curve trends of the pre-run resistive discharge of the drive pack with those of the post-run resistive discharge, the effective power drawn (ΔE_c) from the withdrawable power capacity of the drive pack incurred during a PAGD run, was ascertained. This represents the power consumption during the run, and the experimental value thus recorded constitutes the actual power figure that must be matched for break-even to occur. Hence, the break-even value equals, by definition, the electrical energy input to the system. Similarly, a comparison of the charge pack pre-run and post-run resistive discharge curve trends identified the effective power (ΔE_{rth}) added to the withdrawable capacity of the charge pack. This quantity represents the electrical energy recovered during the run. The relation for the two quantities is expressed by the break-even efficiency equation:

$$\% = \Delta E_{rth} / \Delta E_c \times 100$$

If the break-even efficiency is less than 100%, then the apparatus registers a net loss in electrical energy in the CP with respect to the DP. Conversely, if the efficiency exceeds 100%, then there is a net gain in electrical energy in the CP, as compared to that lost in the DP. For purposes of this analysis, a limit to the minimum withdrawable capacity was placed, from experiment and in agreement with the load current curves of the manufacturer, at 115 W for the driver pack (average current of 0.250 A, minimum current of 0.230 A), and at 90 W for the charge pack (average current of 0.375 A, minimum current of 0.334 A), as a function of both their total cell size (respectively, 46:29) and the difference in the resistive loads employed for the discharge measurements. All cathodes had been broken in, as described before.

The results obtained with this fourth method, for six selected experiments with three diverse types of devices (using different electrode plate areas, gap lengths, and electrode work-functions), configured both in the triode or the (single) diode (e.g. **Fig.10B**) arrangements, at the indicated pressures, are presented in Table 8. In all cases, a net excess of combined battery pack charge, expressed as electrical watt hours, is registered (columns 8 and 10, Table 8) and the break-even efficiencies are all >100% (column 10). Experimental groups 1 and 2 again demonstrate that, for the same cathode, the interrupted PAGD sequence method of group 2 (1 minute of PAGD function, followed by a 15 minute relaxation, and so on) yields a higher break-even efficiency because of the lower losses registered with this minimal plate heating method (column 10, Table 8). Group 3 of Table 8, shows that the PAGD power production efficiency is also higher for a lower work-function cathode material (H220 vs H34), being subjected to PAGD auto-electronic conditions at a 4-fold lower pressure than the control groups 1 and 2; however, the lower pressure depresses the frequency and, together with the interrupted PAGD sequencing method, it also lowers the loss, causing an actually much larger break-even value than registered for the previous two groups. Groups 4 and 5 exemplify the dual effect of lowering both the plate area and the gap distance: the former affects the PAGD event frequency, whereas the latter affects the PAGD amplitude, and thus the capture efficiency of the charge pack. Despite a cathodic work-function practically and operationally identical to that of groups 1 and 2, these smaller plate area and shorter gap devices utilised in groups 4 and 5, yield 3- to 6-fold lower net power outputs, as well as lower break-even efficiencies, than the former groups, at the same pressure. Finally, group 6 exemplifies the results obtained for the plate diode configuration, where the frequency is lower (no triggering role for the axial member), and a higher loss leads to the lower break-even efficiency, comparable to that of the lower area and shorter gap groups 4 and 5.

In order to verify the discharge curve lengths employed in these analyses and experimentally establish the actual charge capacity of the battery packs, calibration resistive discharges, between the maximum charge state and the minimum limits chosen, were performed for each pack with their respective discharge resistances R2 and R3 (see **Fig.9**). These discharge calibration curves were plotted for half maximal charge values shown in **Fig.15A** and **Fig.15B**, and from the curve produced, we have determined the total half-charge capacities of each battery pack to be 1.033 kWh (100%=2.066 kWh) for the drive pack and 660 Whr (100%=1.320 kWh) for the charge pack. Based upon the corresponding maximal (100%) capacity values, we determined the actual percentages of the relative charge capacities shown in column 5, Table 8, which correspond to the experimental values obtained. We also noted that the curves plotted showed two quite distinct time linear slopes, the slope of the delivery of power per time unit steepening very markedly at the approach to the limits of the permissible withdrawable capacity, occurring at 115 W into **R2**, and 90 W into **R3**.

The pre-PAGD run and post-PAGD run, drive and charge pack discharge curves corresponding to groups 3 and 6, respectively for triode and plate diode configurations, in Table 8, are shown in **Fig.16** (drive pack) and 17 (charge pack), for group 3, and in **Fig.18** (drive pack) and **Fig.19** (charge pack), for group 6. In all cases, the open symbols represent the pre-PAGD run discharge curves, whereas the closed symbols represent the post-PAGD run discharge curves.

As a further check on these values, a videographic, millisecond analysis of the singular power simultaneities occurring at both ends of the system (drive and charge packs) was performed for various 10 second samples of diverse PAGD runs. A typical example is shown in **Fig.20**, which is a sample of the PAGD run designated as 6 in Table 8. While the drive pack DC wattage spent as input to PAGD production varied from 36.6 to 57.82 watts, by a factor of 1.6 times, the DC wattage entering the charge pack as captured PAGD output varied more pronouncedly by a factor of 2.7 times, from 146.4 to 399.6 watts (all meters were in the same selected ranges of voltage and current) with the semi-periodic, intermittent character of each singular emission, though within specific, ascertainable ranges for both amplitude and current outputs.

Assimilation of the singular behaviour of the PAGD in this sample, by a statistical treatment of its variation (with $n = 64$), indicates that the operational break-even efficiency observed during this sampled period lies at 485.2% +/- 18% with projected 48.3Wh drive pack loss and 221.7Wh charge pack gain. This matches rather closely the observed 483% break-even efficiency, and the 37.7Wh loss as well as the 182.2 kWh gain for the overall PAGD run reported in group 6 of Table 8, and indicates how close are the values obtained by the operational and extensive non-negligible resistive discharge power measurement methods employed.

Finally, an example of the correlation between the drive pack PAGD load voltage and the charge pack PAGD charging voltage, as a function of the duration of the intervening PAGD run between resistive discharge measurements, is shown in **Fig.21**, for the PAGD run corresponding to group 4 of Table 8.

Using the same pulse generator with H200 Al 128 cm² plates, in a double diode configuration, and the same circuit values (but with CP = 23 cells), three experiments were conducted at different PAGD frequencies, as a function of varying air pressure. Analysis of driver pack losses and charge pack gains by the extensive load discharge measurement method, as described before, led to the determination of the gross and net gains (respectively, without and with losses included) per pulse, in milliwatt-hour, for each frequency, as well as of the gross and net power gains per second of PAGD operation. The results are shown in Table 9. Even though the gross and net gains of power per pulse were observed to increase with decreasing frequency, the gross power gain per unit time increased with increasing frequency. However, this last trend does not necessarily translate into a higher net gain per unit time, because the losses in the driver pack (not shown) also increase significantly with PAGD frequency. These losses are in all probability related to more energy retention by the plasma at higher frequencies when plasma extinction becomes incomplete. We expect net gains to reach optimal thresholds for any given type of circuit configuration set of values and pulse generator dimensions.

Certain additional observations made during experiments with the double diode configuration of **Fig.10A** may assist in understanding of the invention.

1) Replacing residual air with argon gas leads to higher PAGD frequencies, as noted by us when utilising a 128 cm² H200 AC plate pulse generator in the double diode configuration ($V = 575$). At 1 Torr, the pulsation rate went from 20 PPS in air to 1300-1400 PPS in argon. With 29 12V cells in the charge pack, input currents ceased to flow into it. Under these conditions, the tube potential across the plates decreased and the drop across the input resistor increased. The value of $E (= V/d)$ became smaller (gap size = 3 cm from plate to axial anode collector), as the extinction voltage decreased.

2) With frequencies of 400 PPS, the currents flowing into the charge pack fell to zero. Replacing a fast-recovery type HFR 120 (1200v, 40A) diode bridge by a type MUR 860 (600v, 8A) diode bridge had no effect. When the amplitude of plate potential oscillations falls below the potential of the charge pack, there is also a tendency to produce arc discharges. For output currents from the vacuum pulse generator to enter the charge pack, the number of cells must be reduced so that the potential of the charge pack is low enough to admit the transduced currents. A reduction from 29 to 23 cells allowed currents of 250 mA to enter the CP, and further reduction to 19 cells doubled these currents (per polarity arm).

3) Our observations show that it suffices under these conditions (CP of 19 cells) to increase the vacuum, so that the frequency decreases, and the plate potential and the charge pack input currents increase. At 0.1 Torr, the currents reached 1A DC per plate, and at 0.05 Torr, 2A DC

The interconnection between these factors indicates that the extinction voltage is a function of the PAGD frequency: the higher the PAGD frequency, the lower the extinction voltage, until empirical (in distinction from predicted) VAD field values are reached. As a consequence, the start voltage of the charge pack must be adjusted, by varying the number of cells composing it, so that it lies below the lowest extinction voltage of the PAGD, for any given geometry and gap distance.

Secondly, as the ion plasma is made more rarefied, the frequency of the emissions decreases, but the peak values of the output voltage and current per pulse increase. The slower the PAGD and the more rarefied the atmosphere, the higher is the output energy produced by the system relative to the input energy.

Autographic analysis of PAGD-induced cathode craters in H34 plates was performed, and their average inner diameter and maximum depth were determined. Similar studies were performed for PAGD-induced craters in Alzak (trade mark) plates. The secondary craters characteristically found in Alzak plates, along fracture lines irradiating from the main crater, are absent in H34 plates; instead, in H34 plates, one observes a roughened surface surrounding the emission crater, quite distinct from the original rough aspect of the pulled finish of these hardened aluminium plates. Also, unlike the Alzak main craters, the H34 craters often have a convex centre occupied by a cooled molten metal droplet, whereas the Alzak craters had a concave, hollowed out aspect. Eventually, as the pitting resulting from PAGD cathodic emissions covers the entire cathode, the metallic surface gains a very different rough aspect from its original appearance. In this process, craters from earlier metal layers become progressively covered and eroded by subsequent emissions from the same cathode. Altogether different is the surface deposition process occurring at the anode; here, the surface appears to become more uniform, through the mirroring and possibly abrasive actions of cathode jets. Macroscopically, with increased periods of PAGD operation, the anode surface appears cleaner and more polished.

With the data obtained by the metallographic method of crater measurement, we estimated the volume of metal ejected from the cathode, by assuming that the crater represents a concavity analogous to a spherical segment having a single base ($\frac{1}{6}\pi \times H [3r^2 + H^2]$, where **H** is the height of the spherical segment and **r** the radius of the sphere), while disregarding the volume of the central droplet leftover from the emission. The following are mean +/- SEM crater diameters (D), crater depths (H) and maximum volumes (V) of extruded metallic material for two types of aluminium cathodes, Alzak and H34 hardened aluminium, subject to a high input current PAGD:

1. Alzak: D -0.028 cm +/- 0.003; H -0.002 cm +/- 0.0002; V - $6.2 \times 10^{-7} \text{ cm}^3$
2. H34: D -0.0115 cm +/- 0.0004; H -0.0006 +/- 0.0001; V - $3.1 \times 10^{-8} \text{ cm}^3$

Accordingly, utilising plates composed of either material with 3 mm of thickness, and thus with a volume of 38.4 cm^3 per plate and considering that only 2/3rds of the cathode shall be used (a 2 mm layer out of the 3 mm thickness), the total number of pulses per plate total (TLT) and partial (PLT) lifetimes is theoretically:

1. Alzak: TLT: 6.2×10^7 pulses; PLT: 4.1×10^7 pulses;
2. H34: TLT: 1.2×10^9 pulses; PLT: 8.1×10^8 pulses.

Typically, an H34 device can produce about 0.25 kWh per 10,000 pulses. The corresponding value for a PLT is thus a minimum of 1.0 MWh/Alzak cathode and of 20 MWh/H34 cathode. As the cathode for each combination is only 66.7% consumed, the vacuum pulse generator may continue to be used in a reverse configuration, by utilising the other plate in turn as the cathode; thus, the estimated minimal values become, respectively, 2.0 MWh/Alzak pulse generator and 40 MWh/H34 pulse generator. The same rationale applies for the double diode configuration of **Fig.10C**.

We have created a two-ported system for the production of the singular discharge events which we have previously identified in the "863" application as an endogenous pulsatory abnormal glow discharge regime where the plasma discharge is triggered by spontaneous electronic emissions from the cathode. We have examined the functioning of this two-ported system in order to determine what were the electrical power input and output characteristics of a sustained PAGD regime. Despite the wide (10-fold) variations in net power and break-even efficiencies measured by the four different methods employed (open voltage measurements, time integration of negligible power measurements, operational power measurements and real time non-negligible power measurements), all methods indicate the presence of an anomalous electrical transduction phenomenon within the vacuum pulse generator, such as can result in the production at the output port of electrical energy measured and directly captured which is greater than would be anticipated having regard to the electrical energy input at the input port. With the most accurate of the methods employed, we have found typical PAGD power production rates of 200 WHr/hour of PAGD operation, and these may reach >0.5 kWh/h values.

The discrepancies between the methods utilised have been extensively examined in the preceding section. Our systematic approach demonstrates that the most frequently employed method of measuring the charge capacity of batteries by the open voltage values is the least reliable approach for the determination of the actual net power lost or gained by the battery packs used in the system: when compared to all three other methods, it overestimates net power consumed and produced by up to 10 fold, as well as distorting the break-even efficiencies, particularly at the extremes of operation. All this results from the grossly diminished (50-60% of manufacturer's theoretical estimate) effective charge capacity of the lead acid gel cells employed, as determined experimentally from **Fig.18** and **Fig.19**, when compared to the theoretical maximal charge capacity values that serve as scale for the open voltage measurements. In other words, the effective energy density of the batteries during these experiments was in fact approximately half of the manufacturer's estimated 30 WHr/kg.

Under these actual conditions of battery performance, the third and fourth methods (respectively, operational and real-time non-negligible power measurements) of power consumption and production proved to be the best approach to measure both PAGD electrical power input and output, as the results of both methods matched each other closely, even though the former is a statistical treatment of simultaneous events and the latter is a real time integration of their cumulative effects. The second method is clearly less reliable than either the third or the fourth methods, and this stems from the fact that the power consumption slopes of negligible resistive discharges not only are very different from the quasi-steady state discharge slopes (beginning at >5 - 15 minutes) of extensive resistive discharges, but also their proportionality may not reflect the real time proportionality of equivalent prolonged resistive discharges.

The main advantage of the fourth method is that it effectively takes into account the actual time performance of the batteries comprised by the overall PAGD production and capture system we have described. As such, the method may have the main disadvantage of reflecting more the limitations of the batteries employed (their high

rate of degradation of the absolute value of total effective charge capacity, and limited efficiency in retaining charge derived from discontinuous input pulses) than indicating the actual power output. There are a number of possibilities for fine tuning of the system introduced by the present work, beginning with the utilisation of secondary batteries or other charge storage or absorption devices that have less variable or more easily predictable actual charge capacity.

In this respect, there are two major shortcomings to the batteries used to form the drive and charge packs; (1) their significant memory effect and (2) their design for constant, rather than discontinuous, DC charging.

Recently developed Nickel Hydride batteries are an example of an electrostatic charge-storage system that lacks a substantial charge memory effect, and their experimental batteries are being developed currently for higher efficiency intermittent charging methods. Electrostatic charge retention systems having better energy densities, better charge retentivities and insignificant memory effects will probably be more efficient at capturing and holding the energy output by the circuit. In practical embodiments of the invention, effectiveness in charge utilisation will be more important than measurability, and any device that will use the energy effectively whilst presenting an appropriate back EMF to the system may be utilised.

The effect of the performance characteristics of the drive and charge packs is only one amongst many parameters affecting operation of the invention. As shown by our extensive investigation of the diverse PAGD phenomenon the recovery of energy from it by electromechanical transduction as in the "531" application, or electrostatic capture as described above, the factors involved in modulating the frequency, amplitude and peak current characteristics of the PAGD regime are complex. Manipulation of these factors can improve electrical energy recovery, or reduce it or even suppress PAGD. We have so far noted numerous factors that affect PAGD frequency and some amongst those that also affect the PAGD amplitude. Aside from these factors, the circuit parameters of the output port portion of the circuit, in addition to the nature and chemical characteristics of the battery cells already discussed, the charge potential of the charge pack, the characteristics of the rectifiers in the recovery bridge in relation to the period of PAGD super-resonant frequencies, and the effective values of the parallel and transversal capacitance bridges can all influence the results achieved. Certain factors however have a radical effect on PAGD operation, such as the gap distance and the charge pack potential.

Too small a gap distance between the cold emitter (cathode) and the collector will result in an increasing reduction in energy recovery. The potential presented by the charge pack must be less than the voltage amplitude developed by the PAGD, as specified by a given gap distance at a given pressure. Too large a charge pack size with respect to PAGD amplitude and the gap length will preclude PAGD production or result in extremely low PAGD frequencies. In brief, the energy absorption rate and the counter potential presented by the charge pack or other energy utilisation device are important factors in the operation of the circuit as a whole, and should either be maintained reasonably constant, or changes should be compensated by changes in other operating parameters (as is typical of most power supply circuits).

Since our test results indicate that the electrical power output of the circuit can be greater than the electrical power input to the circuit, the circuit clearly draws on a further source of energy input. Whilst we do not wish to be confined to any particular theory of operation, the following discussion may be helpful in explaining our observations. These observations have been discussed in some detail so that the phenomenon observed can be reproduced, even if the principles involved are not fully understood.

In the "863" and "531" applications we have identified a novel, cold-cathode regime of vacuum electrical discharge, which we have termed the pulsed abnormal glow discharge (PAGD) regime. This regime, which occupies the abnormal glow discharge region of the volt-ampere curve of suitable discharge tubes, has the singular property of spontaneously pulsing the abnormal glow discharge in a fashion which is coming from the tube and its circuit environment that constitutes a vacuum pulse generator device, when it is operated under the conditions which we have identified. In fact, when stimulated with continuous direct current, in such conditions, such a circuit responds with spontaneous abnormal glow discharge pulses that enable effective segregation of input and output currents.

We have demonstrated electrically, metallographically, oscillographically and videographically, how the pulsed discontinuity results from a self-limiting, auto-electronic cathode emission that results in repeated plasma eruptions from the cathode under conditions of cathode saturated current input. The auto-electronic triggering of the PAGD regime is thus akin to that of the high-field emission mechanism thought to be responsible for vacuum arc discharges (VAD regime). However, under the PAGD conditions we have defined, this mechanism is found to operate in the pre-VAD region at very low field and low input average direct current values, with very large inter-electrode distances and in a self-limiting, repetitive fashion. In other words, the PAGD regime we have identified has mixed characteristics: its current versus potential (abnormal glow) discharge curve is not only distinct from that of a vacuum arc discharge, but the electrical cycle of the PAGD regime itself oscillates back and forth within the potential and current limits of the abnormal glow discharge region, as a function of the alternate

plasma generation and collapse introduced by the discontinuous sequencing of the auto-electronic emission process. Accordingly, the intermittent presence of the abnormal glow, as well as the observed segregation of the current flows, are due to the diachronic operation of these spontaneous cathode emission foci. The micro-crater and videographic analyses of the PAGD have demonstrated the presence of an emission jet at the origin of each pulse, a phenomenon which VAD theory and experiment has also identified. Metallic jets originating at the cathode spots of VADs have been known to present velocities up to, and greater than 1000 m/sec.

In light of the above, the energy graft phenomenon we have isolated would have to be operated, at the micro-event scale, by the interactions of the cathode emission jet with the vortex-formed impulse-transducing plasma in the inter-electrode space. Several aspects can be approached in terms of the complex series of events that constitute a complete cycle of operation, on a micro-scale. There are interactions within the cathode, interactions at the cathode surface, interactions between the emission jet and the plasma globule close to the cathode, and finally, interactions of the resulting electron and ion distributions in the inter-electrode plasma, within parallel boundaries.

In general, in the presence of an electrical field, the distribution of potential near the cathode forms a potential barrier to the flow of electronic charge, as this barrier is defined by the energy that the most energetic electrons within the metal (the Fermi energy electrons) must acquire before freeing themselves from the cathode surface potential, to originate an emission jet. Before any free electrons become available for conduction in the space adjoining the cathode, they must cross the boundary posed by the potential barrier. With a weak applied field, classical electron emission from a metal can only occur if an energy practically equal to the work-function of the metal is imparted in addition to the Fermi energy. Under thermionic conditions of emission, the heating of the cathode provides the needed energy input. However, the cold-cathode Fowler-Nordheim quantum-field emission theory predicted the existence of a finite probability for an electron to tunnel through the potential barrier, when the applied field is high. Cold-cathode electron emissions are thus possible, under these conditions, at practically Fermi energy levels, as the high field would catalyse the tunnelling through the potential barrier by narrowing the barrier width for the Fermi energy electrons. The exact localisation of the emission would then depend on the randomised fluctuations of high fields at the cathode, which were produced by positive space charges sweeping in proximity to it.

For most purposes, this theory has been the working hypothesis of the last 60 years of field emission studies, which have centred upon the VAD mechanism, despite the fact that observed field gradients are evidently inadequate to explain breakdown as a function of the theoretical high field mechanism. The Fowler-Nordheim theory has therefore suffered major revisions and additions, mostly to account for the fact that it postulates, as a condition for cold-cathode field emission in large area electrodes, the presence of enormous fields ($>10^9$ V/m) and extremely low work functions, neither of which are borne out by experimental VAD investigations. Some researchers have found that the breakdown responsible for the VAD field emission is promoted by Joule heating and vaporisation of microscopic emitter tips, and that this requires a critical current density (10^{12} A/cm²), while others emphasised that this explanation and these thresholds did not hold for large area emitters and that a space charge effect of concentrating the ion distribution near the cathode promoted breakdown under these circumstances, when the field reached a critical value; large field enhancement factors (more than a thousand-fold) have been postulated to explain the discrepancy between theoretical predictions and experimental findings regarding the critical breakdown field values, and others have demonstrated how this critical field value effectively varies with work-function and electrode conditioning.

The PAGD regime and its self-extinguishing auto-electronic emission mechanism stands as an exception to the high field emission theory as it currently stands with all its modifications, especially given that in this phenomenon we are confronted with a cathode emission that spontaneously occurs across the large gaps in large plate area pulse generators, at very low field values (down to $<1 \times 10^4$ V/m), as shown above and in the "863" application. Moreover, a Fowler-Nordheim plot (in the form $\text{Log}_{10}(I/V^2)$ versus $1/V$) of the PAGD volt-ampere characteristic exhibits a positive slope, rather than the Fowler-Nordheim negative slope characteristic of VAD field emission. However, current density values obtained from correlations of autographic analysis of the cathode with an analysis of event-oscillogram (peak pulse currents), indicate that the PAGD current density J may reach values of 10^5 to 10^7 A/m² during the emission process (the larger Alzak craters have an associated lower J value), values which, at the upper end, do not reach the 10^9 A/m² current density threshold required by the Fowler-Nordheim theory. Considering these two distinct observations with regards to field strength and current density, we have to admit the existence of a low field, large area cold-cathode auto-electronic emission endowed with high current densities, which is not predicted by current field emission theory.

Unlike the typical VAD regime, the PAGD is neither a high frequency oscillation, nor does it occur in a random fashion. It constitutes a semi-regular, quasi-coherent, periodic energy transduction which cycles between cathode drop limits that are higher by a factor of 2 to 15 than typical vacuum arc cathode drops. The intermittent cathode emission responsible for the low frequency, pulsed behaviour of the abnormal glow, is also self

extinguishing and self-starting, under the conditions we have defined. Furthermore, we have also identified a novel and unexpected dependency of the periodic pulse rate upon the cathode area. This indicates the presence of field emission control parameters heretofore unsuspected. It is likely that field fluctuations of the polarised pre-breakdown field is responsible for eliciting the particular localisations of the auto-electronic emission foci, as well as what imparts, in a lens-like fashion, the distorted field energy needed for electron surface release. In this sense, external, electrical or magnetic field fluctuations (e.g. motion of static charges or of constant magnetic fields) induced by us at pre-breakdown potentials, provoked PAGD emissions and breakdown at these levels.

In general, VAD studies have shown that, for large area electrodes, microgeometry, adsorbed gas layers and gas impurity contents of the cathode play a role in modulating field emission. In our PAGD studies, the interactions at the cathode surface and across the cathode potential drop are clearly modulated by:

- (1) the nature of residual gases, as shown by our air vs Argon studies;
- (2) their pressure,
- (3) electrode conditioning,
- (4) work-function and
- (5) cumulative pulse count, amongst others.

The plasma, in leak-controlled or low pressure PAGD devices, has both residual gas and metallic vapour substrates. In devices initially closed at high to very high vacua (diffusion pump pressures), the major residual substrate, whose presence increases with time of operation, is the metallic vapour released from the cathode and not impacted on to the envelope walls or the anode. It has been previously shown for externally (magnetically or electrostatically) pulsed plasma accelerators, that the amount of residual gas or vapour left in the inter-electrode space diminishes with increasing number of consecutive discharges and a growing amount of electrode-insulator absorption of gas. The effect of such removal of residual gas or vapour is to decrease the vacuum of a sealed envelope. With high vacuum sealed PAGD generators we have observed that prolonged operation and sputter-induced mirroring of the envelope causes a progressive disappearance of the discharge, as the voltage potential needed to trigger it also increases. At the thermocouple, low frequency pulsed abnormal glow discharges can also be seen to increase the vacuum significantly. These results suggest instead the presence of a pumping mechanism in the PAGD which is somewhat analogous to that of sputter ion pumps, where collision of ionised gas molecules with the cathode is responsible for the sputtering of cathode material that either combines with the gas substrate (‘gettering’ action) or ‘plasters over’ the inert gas molecules on to the anode (a process known as ‘ion burial’). These are the two basic pressure reducing actions of sputtered getter atoms, in ion pumps.

However, in ion sputter pumps, the initiation of the cycle is a function of the presence of high velocity electrons in the high field plasma of the glow discharge, which are necessary to ionise the gas substrate molecules; also, the getter material typically has a high work-function for field emission. Hence, the sputtering is due to the secondary impact of plasma positive ions at the cathode, after plasma ionisation has occurred in the inter-electrode space. Altogether different is the mechanism of spontaneous, primary electron emission from the cathode, which is characteristic of the low field PAGD: here, the sputtering is caused by the electronic emission itself and attendant metallic vaporisation processes. By artificially confining the firing foci to a part of the cathode, we have shown in the single diode configuration how the PAGD induced sputtering is associated with the cathode auto-electronic emission mechanism, rather than with the abnormal cathode glow per se, given the localisation of sputtering on to the emission region of the plate, despite its overall cathode glow saturation.

These observations would thus seem to corroborate the hypothesis of a progressive vacuum increase with the cumulative number of emitted pulses, were it not for the fact that experiments performed with leak controlled devices (reported here and in previous studies) show that, when the negative pressure is maintained by balanced leak admission of air or argon, pulse rates still decrease with cumulative pulse count, and do so neither as a function of an increase in vacuum, nor as a function of envelope mirroring (unless this is so extensive as to establish envelope conduction), but rather as a function of processes (generally referred to as conditioning) inherent to the electrodes, specifically, to the cathode. We have further shown that, for such altered emitter states, the pressure of the vessel must be increased, not because of an increasing vacuum (precluded by the controlled gas leak), but because of the effect that residual gases may have in modulating the low field PAGD emission.

PAGD electrode conditioning is a cathode-dominant process resulting from the cumulative emission of high numbers of pulses by a cathode, and has been shown to be a factor independent of the nature and pressure of the residual gas and partially reversible only by operation with reversed plate polarity, unlike reports of copper cathode-dominant conditioning. It is thought that electrode conditioning and the accompanying increase in VAD breakdown potential are due to the progressive adsorption of residual gases, though cathode-dominant conditioning processes, such as subjecting the vacuum gap to consecutive discharges, have been shown to correlate the decrease in plasma impulse strength with electrode outgassing of absorbed or adsorbed gases. Moreover, given the pitting action of crater formation at the cathode by the PAGD regime, and, as we shall see below, the metallic plating of the anode, the PAGD cathode-dominant process of conditioning we have observed with respect to decreased pulse frequency and increase in potential, suggests that the apparent increase in

cathode work function is not due to gas adsorption or absorption. These processes are more likely to occur on the plated anode. It is likely that, given the observed PAGD pressure reducing effect caused by the cathodic jet, a certain outgassing of the cathode is in fact occurring during PAGD function.

One might also expect that the anode, if plated by sputtering atoms, would increase its gas content in the formed surface film. However, controlled leak experiments suggest instead that some other type of alteration of the cathode work function is occurring, which is, as we shall examine below, independent of the adsorbed gas state of the electrodes, as well as independent of the PAGD ion pump-like effect. Nonetheless, even at the level of the anode, the PAGD sputtering action may have contradictory effects: it may impact inter-electrode gap molecules on to the collector, as well as release, by ionic bombardment and vaporisation, gases adsorbed to, or contaminating the anode. If we assume that gas adsorption by impact on the collector is the predominant mechanism, one could explain the increase in the number of breakdown sites per unit time, as observed by us for a re-reversed cathode, if the number of PAGD breakdown sites depended on the quantity of adsorbed gases, e.g. oxygen, on the cathode being tested. Recovery of the cathode work-function would depend on the electronic charge recovery of the positively charged, adsorbed or occluded gas layer at the cathode- either by reversal or as a function of time of inactivity.

The surface film theory of "electrical double layer formation at the cathode" in fact contended that, low field flash over is a photocathodic effect dependent upon the presence of a glowingly positively polarised gaseous film at the cathode; this film would lower the cathode emissivity by decreasing the field between the cathode surface and the leading edge of the cathode glow, across the cathode drop. However, even though the surface film theory of "electrical double layer formation at the cathode" predicts the lowering of the emission breakdown potential and the increase in flash over rate when the electrodes are reversed - as the anode would have acquired a surface charge capable of affecting the breakdown potential, it acknowledges nevertheless, that the anodic surface charge hardly explains the observed intensity of the polarisation effects.

Moreover, non-reversed, conditioned cathodes retained their lower PAGD frequencies in a time-independent manner, for as long as reversal was avoided (excluding a PAGD frequency recovery effect due to plate cooling, which may be as short as 15 minutes). PAGD conditioning was independent of idle time and increased with cumulative pulse count. Moreover, the AGD pulses are not UV photocathodic Townsend discharges, liberating secondary electrons via positive ion impact at the cathode. Nor could photocathodic emissions generate currents of the magnitude observed in the PAGD. Lastly, the PAGD discharge and breakdown thresholds appear to be unaffected by UV, though they may be somewhat depressed by visible light, and the emission mechanism in the PAGD is the primary process.

Removal or flattening of protuberances and tips from the emitting cathode by the action of the discharge, is a process also thought to play a role in hardening the cathode or increasing its field emission work-function. However, this explanation may not be adequate for the PAGD emission process, if we consider our metallographic findings of a smoothing action of the discharge at the collector. In fact, it would appear that the flattened, smoother, plated, mirrored and cleaner surfaces subjected to PAGD bombardment are the explanation for the observed increased emission ability of re-reversed cathodes: mirrored Alzak surfaces emit at higher frequencies than do dull H34 and H220 surfaces; new, polished surfaces emit at a higher frequency than do pitted, broken-in surfaces; anode surfaces, never before utilised as cathodes but subjected to prolonged PAGD action, emit at higher frequencies when employed as cathodes, than do new, identical cathode surfaces; and ex-cathodes, employed for prolonged periods as anodes, regain a higher emission frequency upon re-use as cathodes. The better PAGD emission performance of smoother cathodes, compared with the worse VAD emission performance of the same, when pitted cathodes (lacking protuberances) are used, requires explanation.

Rakhovsky has put forth a VAD model for cathode spots, that distinguishes between Type I spots (quickly moving spots, far from steady state and responsible for crater formation), and Type II spots (quasi-stationary and near steady-state, but leaving an itinerant track with no sign of crater formation). Whereas the former would obey the Fowler-Nordheim requirement for high fields ($>10^9$ V/m), the latter could hardly be expected to do so with typical arc voltage drops in the order of 10 V. Once again, autographic analysis of the PAGD emission aspect indicates mixed characteristics: the PAGD cathode spot is a hybrid. It behaves as an intermittent instability that leaves single (e.g. in H34) or clustered (e.g. in Alzak) craters, which are both qualities of Type I cathode spots; and it exists under low field conditions ($<10^5$ V/m), with cathode drops of 20 to 150 V, in a quasi-coherent mode, leaving an itinerant track of successive craters when operating at the higher frequencies, all of which are properties approaching those of a VAD Type II cathode spot.

Furthermore, the macroscopically visible metal sputtering (due to the explosive action of the PAGD emission phenomenon) occurring at the upper end of the permissible DC current input scale, and the presence of large solidified molten metal droplets in and around the craters, suggest models which have been proposed for explosive electronic emission. Explosion models propose that the creation of a residual plasma ball in front of a microprotuberance provokes the large potential drop at the prospective emission focus and sufficiently high

resistive and Nottingham heating to reach $>10^7$ A/cm² current densities during the explosive consumption of these microemitters. Whether the explosive action associated with cathode spots is an auxiliary effect that applies solely to the vaporisation of the emitting microprotrusion, or an integral emission and vaporisation explosive process, it does not appear that it can be restricted to high-field VAD Type II cathode spots, given that it can be equally made to occur with the low field PAGD hybrid cathode spot, and be macroscopically observed. Indeed, in the plate diode configuration, it is easy to visualise the metallic particle explosions that surround and accompany the plasma jets, near to upper current limit conditions. However, if we are to assume that any of these models apply to the emission mechanism, we would, in all likelihood, have to conclude that the PAGD initial emission sites must be sub-microscopic (100 to 10 nm), rather than microscopic.

Resolution limits to our own metallographic examination of the smoothing action of the PAGD discharge on the collector would thus have precluded us from detecting formation of such sub-microscopic protrusions, as well as their presence in a "soft" cathode and thus infer their disappearance from a pitted, hardened cathode; but if the disappearance of such sub-microprotuberances were responsible for the observed alteration of cathode work function, one would also thereby have to postulate the existence of a mechanism for microroughness regeneration (e.g.. tip growth) at the anode, in order to explain the observed increased emission upon cathode reversal. Furthermore, this regeneration would have to be actively promoted by operation with reversed polarity, and this is problematic. Focusing of the distorted or magnified field upon alumina inclusions on pure iron electrodes has been demonstrated to degrade breakdown voltage for field emission, but the effect was greater for larger microscopic particles. If we were to apply this concept to our work, it would require the existence of unmistakably abundant microscopic heterogeneities in the quasi-homogeneous electrode surfaces employed, which we did not observe; on the contrary, their absence suggests that either the microroughness responsible for the low field PAGD emission is sub-microscopic, or that the field distortion responsible for eliciting the PAGD is independent of the presence of these protuberances. This last possibility must be taken all the more seriously, in light of the fact that PAGD functioning is able to cover the entire surface of an emitter with craters.

Whereas the discharge potentials observed in the PAGD have been shown to be relatively independent of the kind of gas present, there is a gas effect in the PAGD phenomenon, particularly in what concerns its frequency, observed when the same "run down" cathode was capable of much higher emission rates when exposed to argon, than to air. Utilising the technique of bias sputtering, it has been demonstrated that the number of charge symmetric collisions (dependent upon sheath thickness d and the ion mean free path) in the plasma sheath, which are responsible for lower energy secondary peaks in ion energy distribution $N(E)$, at pressures of 0.2 Torr, is substantially greater in argon than in argon-nitrogen mixtures, and thus that, under these conditions, mostly Ar^+ and Ar^{++} ions impact the negatively biased electrode. In non-equilibrium RF discharges, greater ion densities have also been attained with argon, than with air. With respect to field emissions, one would expect a gas effect only with regards to changes on surface conditions, though such studies have shown contradictory effects of argon upon cathode work function.

In light of the foregoing, and given that the PAGD is an emission discharge and not a sputtering discharge per se, in the strict sense, we can conceive of the role of inert gas atoms in increasing, as compared to air or nitrogen, the ion energy density distribution at the PAGD cathode spot interface with the cathode surface emitter, and thus elicit increased emission rates from the cathode, by pulling electrons from the metal via the field effect. While this is consistent with the concept of focused distortions of space-charge field fluctuations inducing localisation of the emission foci, the argon effect can be observed in the PAGD regime over the entire range of the Paschen low vacuum curve, and into Cooke's mid to high vacuum curve, at low fields and without negative biasing. Thus, it is not simply a high pressure (nor a gas conditioning) effect, even if the gas effect in question applies to the description of a local pressure rise at the emission site/cathode spot interface, which may play a role in enhancing the local field.

Considered together, the PAGD emission-derived sputtering, the observed metallic plating of the anode and the explosive aspect of the discharge, suggest the presence of a jet of metallic vapour present in the discharge and running, contrary to the normal flow of positive ions, from the cathode to the anode. This jet appears to have properties similar to the high speed vapour ejected from the cathode in a VAD, as first detected by Tanberg with his field emission pendulum (Tanberg, R. (1930), "On the cathode of an arc drawn in vacuum", Phys. Rev., 35:1080) In fact, the VAD high field emission process is known to release, from the cathode spot, neutral atoms with energies much greater than the thermal energy of the emission discharge. This anomalous phenomenon brings into play the role of the reported cathode reaction forces detected in vacuum arc discharges (Tanberg, as above, also Kobel, E. (1930), "Pressure and high vapour jets at the cathodes of a mercury vacuum arc", Phys. Rev., 36:1636), which were thought to be due to the counterflow of neutral metallic atoms, from the cathode on to the anode (charged metallic ions are normally expected to target the cathode). In absolute units of current, this current quadrature phenomenon has been shown to reach, in the VAD regime, proportions of the order of $100 \times I^2$ (see also the Aspden papers referenced below).

Early interpretations attributed this to the cathode rebounding of <2% of gas substrate-derived plasma positive ions hitting the cathode and being charge-neutralised in the process, but having kept most of their thermal energy. Tanberg held instead that the counterflow of neutral particles responsible for the cathode reaction force was cathode derived, effectively, that it constituted a longitudinal interaction acting in the direction of the metallic arc jet. However, even though secondary high energy distributions of neutral atoms emanating from the cathode do not have thermal energies, their modal distribution does (Davis, W. D. and Miller, H. C. (1969) *J. Appl. Phys.*, 40:2212) furthermore, the major anomalous atomic counterflow that accompanies the high-energy electron flow toward the anode, was shown mass spectrographically to consist predominantly of multiply ionised, positively charged ions of cathode metal, rather than neutral atoms. If this made it easier to abandon the primacy of the rebounding model, it was now more difficult for field emission theorists to accept and explain the observed high energies (ion voltages in excess of the discharge voltage drops) and the high ionisation multiplicity associated with these counter-flowing positive ions.

This field of investigation has indeed been one of the mounting sources of evidence suggesting that there is something amiss in the present laws of electrodynamics. The anomalous acceleration of counter-flowing ions, and the energy transfer mechanisms between high speed or "relativistic" electrons and ions in a plasma (Sethion, J. D. et al, "Anomalous Electron-Ion Energy Transfer in a Relativistic-Electron-Beam-Heated Plasma" *Phys. Rev. Letters*, Vol. 40, No. 7, pages 451-454), in these and other experiments, has been brilliantly addressed by the theory of the British physicist and mathematician, H. Aspden, who first proposed a novel formulation of the general law of electrodynamics capable of accounting for the effect of the mass ratio factor (M/m) in the parallel (and reverse) motion of charges with different masses, (Aspden, H. (1969) "The law of electrodynamics", *J. Franklin Inst.*, 287:179; Aspden, H (1980) "Physics Unified", Sabberton Publications, Southampton, England). The anomalous forces acting on the counter-flowing metallic ions would stem from their out-of-balance interaction with the emitted high speed electrons, as predicated by the electrodynamic importance of their mass differential. This results in a fundamental asymmetry of the plasma flow between electrodes, localised on to the discontinuous interfaces of the plasma with the electrodes, namely, in the cathode dark space and in the anodic sheath: on the cathode side, electrons act upon ions, as the emitted electrons having less than zero initial velocities, drift against the incoming ion flux and in parallel with the ion and neutral counterflows; on the anode side of the discharge, positive ions flowing toward the cathode confront mainly the incoming counterflow of positive ions and neutral atoms, as the high speed electrons have abnormally transferred their energy to counter-flowing, high speed, cathodic metal ions. An out-of-balance reaction force thus results at the cathode, to which the leaving metallic atoms impart a force of equal momentum but opposite direction, a force which is added to the cathode momentum generated by impacting, normal flowing positive ions.

Moreover, Aspden confirmed theoretically the fundamental contention of Tanberg's experimental findings that an electrodynamic force will manifest itself along the direction of the discharge current flow, and thus, that the atomic counterflow is a metallic jet. Aspden further demonstrated that this asymmetry of plasma discharges does not imply any violation of the principles of conservation of energy and charge equivalence, given that there will be no out-of-balance force when such anomalous forces are considered in the context of the whole system of charge which must, perforce, include the local electromagnetic frame itself. Such discharges must be viewed as open-energy systems, in balance with their electromagnetic environment: their apparatuses may constitute materially closed or limited systems, but they are physically and energetically open systems. Current work on Aspden's formulation of Ampere's Law indicates that both classical electromagnetism and special relativity ignore precisely, in circuits or in plasma, the longitudinal interactions that coexist with transverse ones. Standing longitudinal pressure-waves, of a non-electromagnetic nature, have been previously shown in plasma electrons, which did not conform to the Bohm and Gross plasma oscillation mechanism (Pappas, P. T. (1983) "The original Ampere force and Bio-Savart and Lorentz forces", *11 Nuovo Cimento*, 76B:189; Looney, D. H. and Brown, S. C. (1954) "The excitation of plasma oscillations" *Phys. Rev.* 93:965)

The present theoretical approach to the novel regime of electrical discharge which we have isolated in specially designed devices, and to its mixed glow-arc characteristics, suggests that a similar, out-of balance current quadrature phenomenon occurs in the discharge plasma during the low field, auto-electronic emission-triggered PAGD, and is responsible for the observed surplus of energy in the experimental system described in this report. Clearly, all the evidence we have adduced indicates that there is a powerful longitudinal component to the emission-triggered PAGD, i.e. that the discharge pulses characteristic of this pre-VAD regime are longitudinally propelled jets of cathode-ejected high speed electrons and high speed ions. We have performed experiments, in the PAGD regime of operation, with very thin axial members that bend easily when placed in the path of the discharge, or with Crooke radiometer-type paddle-wheels, and both show the presence of a net longitudinal force in the plasma discharge acting in the direction of the anode, which confirms the magnitude of the atomic counterflow (ionised and neutral) present during the PAGD, very much like Tanberg's pendulum did for the VAD.

These observations also tally with the explosive action of the emission mechanism, such as we have examined it above. In this context, two aspects of the PAGD are remarkable: the fact that a phenomenon akin to field emission occurs at low field values, for large area electrodes across large gaps, and the conclusion that the PAGD must deploy an excessively large counterflow of, in all probability, both ionised and neutral cathodic

particles. The observation of ion current contributions to the cathode current on the order of 8 to 10%, in VADs, can hardly apply to the PAGD mechanism responsible for the anomalous currents and counterflows observed. Hence, we should further expect that the characteristically intermittent, or chopped current regime of the PAGD, is a major factor in the generation of disproportionately high energy longitudinal pulses and in allowing our system to capture most of the electrical energy output from the device. In all probability, field collapse at the end of discharge favours the nearly integral collection of the plasma charge, and ensures the transduction of most of the plasma energy of the pulse (blocked, as it is, from flowing back through the input port to the drive pack) to the output port, through the parallel, asymmetric capacitance bridge that interfaces with the charge recovery reservoir (the charge pack). Collapse of the field of the discharge may also be a contributing factor to the anomalous acceleration of ions, and to the observed anode plating effect.

It is equally possible that such abnormally large longitudinal pulses may never be observable, for a given arrangement and scale, above threshold frequencies of the oscillation; we have, in this sense, presented data that indicates that for a given geometry, above specific PAGD frequencies, the capture of surplus energy decreases steadily in efficiency until it ceases altogether, for a given arrangement. The point at which this surplus begins to decrease coincides with the setting in of frequency-dependent irregularities in the discharge sequence and, most importantly, it coincides with a reduction of the peak pulse current for each PAGD pulse. We have further remarked that increasing the PAGD frequency above the zero surplus point, for a given arrangement, by manipulating any of the frequency control parameters, provokes the slippage of the PAGD into a full fledged VAD regime, while input currents greatly increase and output peak currents greatly decrease (to comparable peak input levels of 10 to 15A).

The transition between the two modes of emission-triggered discharge, PAGD and VAD, thus appears to be tied in to adjustable thresholds in the frequency of the emission discontinuities; in this sense, it is rather likely that the plasma field collapse plays a major role in regularising and optimising the anomalous energies of field emissions, as in the PAGD regime. At low frequencies of low field emission, the emission regime is highly discontinuous, diachronic and regular, for it has time to fully extinguish the discharge; hence the PAGD singularity, in which the phases of each discharge pulse are well defined and sequential. Above a given high frequency, when ion and electron recombination will happen more often, before each can be collected at the electrodes, the stream of emitted discontinuities merges into a noisy, randomised continuum, where simultaneous emissions become possible and the plasma field no longer has time to collapse and fully resolve the longitudinal pulses. Any anomalous energy generated is then minimised and trapped in the plasma body and, in these conditions, the VAD regime eventually sets in. Such model would easily explain why the high field VAD experiments performed to date have never detected such extraordinarily large anomalous forces.

On the other hand, the quasi-coherent aspect of the discharge suggests that the vacuum gap, in functioning during the PAGD regime both as an insulator and as a conductor with capacitive and self-inductive properties, is periodically altered by large and intense polarisations which are resolved by the discrete emission of longitudinal pulses from the cathode. It is possible that these non-linear oscillations resulting from sudden depolarisation of the vacuum gap by high-speed explosive emissions elicited at the convection focus of the distorted field, might be in resonance or near resonance with the external circuitry, but the most apparent effect of increasing the capacitance in all bridge members is to increase the jet current and the transduced current flowing into the charge pack. The PAGD amplitude variation also presents, after the large negative discontinuity, a growing oscillation at very high resonant frequencies, which are typical of inductive chopping currents in a VAD, before extinction occurs. Unlike the VAD inductive case, in the absence of any coils other than the wire wound resistors, the PAGD relaxation oscillations which follow each pulse only extinguish the discharge when the voltage potential of the amplitude curve rises above the applied voltage, just as the plasma potential drops the most.

Given the entirely non-inductive nature of the external circuit utilised in many instances, the inductive properties in evidence are those of the vacuum device itself. It also suggests that, in the absence of any need of an applied external magnetic field for the PAGD discharge to occur coherently, it is possible that the magnitude of the currents generated produces by itself a significant self-magnetic field. Thus, we cannot rule out the possibility of a self-organisation of the plasma discharge, which may, in Prigogine's sense, constitute a dissipative structure (Prigogine, I. and George, C. (1977), "New quantisation rules for dissipative systems", *Int. J. Quantum Chem.*, 12 (Suppl.1):177). Such self-ordering of the PAGD plasma jet is suggested by the experimentally observed transition of these pulses from the current saturated limit of the normal glow discharge region, into the PAGD regime, as a function of increasing current: smaller foci of discharge can be seen to discontinuously agglutinate into larger emission cones, or into jets with a vortex-like appearance, when the input current reaches a given threshold.

It is possible that, under these conditions, the distribution of the charge carriers and their sudden fluctuations may render any steady-state plasma boundary conditions ineffective and provoke a singularity in the discharge mechanism; this non-linear behaviour, together with any self-magnetic effects, might provide radial coherence of the plasma flow along the longitudinal path of the discharge. This concept is akin to what has been proposed for periodically fading-away solution structures referred to as "instantons", that represent self-organising transitions

between the two states of a system. The PAGD may well be an instance of an instanton type structure bridging the open, or conductive, and the closed, or insulating, states of the vacuum gap. An analytical formulation of the problem of the plasma flow from the cathode spot to the anode, which would take into account the self-magnetic and self-organising properties of the PAGD plasma channel, would be extremely difficult, given the out of balance longitudinal force, its abnormal energy transfer and associated counterflow, as well as the competition between collisional and inertial exchanges.

The plating observed at the anode most likely results from the impact of counter-flowing ions (and possibly neutral atoms), whereas the pitting of the (locally molten) cathode results from the emission of vaporised metallic material and electrons, as well as, secondarily, from bombardment by incident positive ions. The first action smoothes the surface by mirroring it (deposition of cathode-derived atoms) and abrading it, whereas the latter smoothes it in places by rounding concavities and by forming molten droplets upon local cooling, while simultaneously roughening it on the crater peripheries. One might think that this cathode roughening should lower the work function and facilitate the discharge, but the facts indicate that just the opposite must be happening in view of changes in the PAGD according to the nature and state of the cathode surface. The observed alterations of electrode work function for PAGD low field emission must thus be related to the molecular and charge effects of these different actions at the two electrodes. It appears that for large parallel plate electrodes, the PAGD low field emission is modulated by the nature and, most likely, by the molecular structure of the metallic surface layer of the emitter.

We have thus devised a system for the capture, as electricity, of the energy of anomalously energetic longitudinal pulses sequentially triggered by spontaneous emissions of high-speed electrons and ions generated from low work function cathodes, during the low field and singularly mixed PAGD regime of electrical discharge in vacuo. To confirm the above interpretation of the anomalous flux in the observed PAGD phenomenon, the cathode jet composition, as well as time-dependent and usage-dependent changes occurring in the tubes, with diverse sealed negative pressures and after submission to prolonged PAGD operation, must be analysed by mass-spectroscopy. In any event, the excess energy present in the anomalous counter-flowing force appears to stem from a discharge mechanism that effectively pulls high speed electrons and constituent atoms out of a metal surface, at low fields and with high current densities, and is modulated by a complex multiplicity of parameters.

The system described appears to transduce efficiently the observed non-linear longitudinal pulse discontinuities of the plasma field, under conditions of current saturation of the cathode, because the self-extinguishing and self-limiting properties of the discharge allows the energy from the collapse of the discharge to be captured. The particular design of the circuitry, which couples a rectification bridge to the asymmetric bridge quadrature of large capacitances, placed at the output of the PAGD generator, permits effective capture. Our findings constitute striking evidence for Aspden's contention of a need to revise our present electrodynamic concepts. The dual ported PAGD discharge tube circuits which we have described are the first electrical systems we know of which permit effective exploitation of anomalous cathode reaction forces and allow for the recovery of electrical energy from systems exhibiting this effect. Any apparent imbalance in the electrical energy input to the system and withdrawn from the system by its operator must be considered in the context of the entire continuum in which the system operates, within which it is anticipated that accepted principles of energy balance will be maintained.

Moreover, the energy conversion system of the invention has substantial utility as an electrical inverter accepting direct current, and providing one or more of a direct current output at lower voltage and higher current, variable frequency input to alternating current motors, and, by suitable combinations of discharge tube systems, more flexible DC-to-DC conversion systems.

As an alternative to the batteries used in the experiments described, a DC power supply may be utilised or, more advantageously from the viewpoint of entailing less transformation losses, a DC generator to provide the electrical energy input to the system. As a DC motor can be run directly from the rectified output of the circuit of **Fig.9** at **EI-E2**, in place of a battery charge pack, DC motor/generator sets of suitable characteristics (in terms of back E.M.F. and circuit loading) can be used to charge the batteries of the drive pack, utilising the rectified PAGD output to drive the DC motor component of the set. This provides a simple, one battery pack solution, where the PAGD input and output circuits are electrically separated by the DC motor/generator interface: the drive pack is simultaneously being discharged to drive PAGD production, and charged by the DC generator output which, in turn, is being driven by the electromechanical transformation of the rectified PAGD output that would typically accrue to a charge pack in the experiments already described. The main limitations to such an arrangement lie in the efficiency of the motor and generator transformations utilised.

A pulsed DC source could be used to provide input to the circuit if suitably synchronised, but care is needed not to interfere unduly with the auto-electronic mechanism of the field induced cathode emissions.

TABLE 1

Results for the ballast resistance (and current) dependent PAGD frequency utilizing an H34 aluminum pulse generator with 128 cm² plates at 5.5 cm distance, in the triode configuration, at a pressure of 0.8 Torr. The circuit employed is that of the present invention, as described in the third Results Section.
DCV = 560.

R in Ω	Regime of Discharge	Pulse Rate > 100 V
5,000	NGD (Cold Cathode)	0
600	PAGD	10 PPS
300	PAGD	40 PPS
150	PAGD	180 PPS
100	VAD	0
50	VAD	0

TABLE 2

128 cm² H220 Al; 570 volts DC; 300 Ω = R1; Diode Configuration

	PPS	p(Torr)	Cumulative Pulse Count
1)	200	0.08	$\sim 2.4 \times 10^5$
2)	200	0.5	$\sim 1.5 \times 10^6$
3)	200	0.8-1	$\sim 2.5 \times 10^6$
4)	25	0.5	3×10^6 pulses
5)	200	0.5	1.5×10^6 (after first electrode reversal)

TABLE 3

RESIDUAL GAS EFFECT

pressure in Torr	PPS	
	in AIR	in ARGON
0.45	ND	10
0.5	1.8 ± 0.3	ND
0.55	4.8 ± 0.9	16.7 ± 1.8
1.0	11.4 ± 0.8	448 ± 27.4
1.25	214.5 ± 14.3	ND
2.0	36.2 ± 2.6	206 ± 19.6
2.5	1.36 ± 0.3	158.7 ± 24
		0

TABLE 4

Charge pack No. of cells	PPS	PAGD
36	0	-
31	1	+
29	10	+
19	1	+
9	0	-

TABLE 5

1	2	3	4	5	6	7	8		9	10		11
Expt.	Battery	Position	Open	V/cell	% total	Max.	% rel. cpty		Total	ΔkWh		PAGD
No.	Pack		Voltage		rel. cpty.	hr. left	gained	lost	kWh	gain	loss	per sec
1	Charge	start	348	12.0	40	8			0.835			8
	Charge	end	366	12.62	83	16.6	43		1.823	0.988		
	Driver	start	576	12.52	77	15.4			2.660			
	Driver	end	572	12.43	70	14		7	2.402		0.258	
2	C	b	331	11.41	2	0.4			0.040			61
	C	a	351	12.1	47.5	9.5	45.5		1.002	0.962		
	D	b	553	12.02	40	8			1.327			
3	D	a	546	11.9	33	6.6		7	1.081		0.246	3
	C	b	345	11.9	32.5	6.5			0.673			
	C	a	361	12.45	72.5	14.4	40		1.559	0.886		
4	D	b	559	12.15	51	10.2			1.710			32
	D	a	552	12.0	40	8		11	1.324		0.386	
	C	b	360	12.41	70	14			1.512			
	C	a	373	12.86	103	>20	33		2.238	0.726		
5	D	b	562	12.22	54.5	10.9			1.838			2
	D	a	557	12.11	48	9.6		6.5	1.604		0.234	
	C	b	340	11.7	20	4			0.408			
	C	a	365	12.59	83	16.6	63		1.818	1.440		
6	D	b	527	11.45	3.2	0.6			0.101			8
	D	a	517	11.24	1.8	0.4		0.2	0.056		0.045	
	C	b	340	11.72	21.5	4.3			0.438			
	C	a	367	12.66	87.5	17.5	66		1.927	1.489		
7	D	b	589	12.8	100	20			3.530			5
	D	a	564	12.26	58.5	11.7		41.5	1.979		1.551	
	C	b	318	10.97	1.2	0.24			0.023			
	C	a	359	12.38	67.5	13.5	66.3		1.454	1.431		
8	D	b	575	12.5	77	15.4			2.656			32
	D	a	567	12.32	63.5	12.7		13.5	2.160		0.496	
	C	b	328	11.71	20	4			0.393			
	C	a	350	12.5	76.5	15.3	56.5		1.606	1.213		
8	D	b	582	12.65	87.5	17.5			3.055			0.134
	D	a	579.5	12.60	84	16.8		3.5	2.921			

1	2	3	12	13		14	15	16	17	18	19
Expt.	Battery	Position	Exptl.	rel. kWh/h		net kWh/h	Breakeven	Cell #/	tube	Cathode	Plate
No.	Pack		time	gain	loss	production	efficiency	pack		Area	
1	Charge	start	21.5'			2.071	388%	29	A26	128 cm ²	H34
	Charge	end		2.791							

TABLE 5-continued

1	2	3	20	21	22	23	24	25	26	27	28	29
Expt. No.	Battery Pack	Position	R1 ohm	C3/C5 mfd	C7a/C7b mfd	Motor arm	Pressure	Gap cm	OV rlx. time	C4 mfd	R4 ohms	Motor rpm
	Driver start Driver end											
2	C	b	18'		0.720		2.387	391%				46
	C	a		3.207								29
	D	b										46
	D	a			0.820		1.396	230%				29
3	C	b	21.5'							A26	128 cm ²	H34
	C	a		2.473								46
	D	b										46
	D	a			1.077		0.465	310%				29
4	C	b	63.5'							A28	128 cm ²	H220
	C	a		0.686								46
	D	b										46
	D	a			0.221		1.064	6,750%				29
5	C	b	80'							A26	128 cm ²	H34
	C	a		1.080								46
	D	b										46
	D	a			0.016		-0.173	96%				29
6	C	b	21.5'							A26	128 cm ²	H34
	C	a		4.155								46
	D	b										46
	D	a			4.328		0.870	289%				29
7	C	b	64.5'							A45	64 cm ²	H34
	C	a		1.331								46
	D	b										46
	D	a			0.461		2.272	906%				28
8	C	b	28.5'							A45	64 cm ²	H34
	C	a		2.554								46
	D	b										46
	D	a			0.282							46

TABLE 5-continued

1	2	3	20	21	22	23	24	25	26	27	28	29
Expt. No.	Battery Pack	Position	R1 ohm	C3/C5 mfd	C7a/C7b mfd	Motor arm	Pressure	Gap cm	OV rlx. time	C4 mfd	R4 ohms	Motor rpm
1	Charge	start	300	20,700	3,300	off	0.8 Torr	5.5	30'	NA	NA	NA
	Charge	end										
	Driver start											
	Driver end											
2	C	b	300	20,700	3,300	off	0.8 Torr	5.5	30'	NA	NA	NA
	C	a										
	D	b										
	D	a										
3	C	b	300	20,700	3,300	off	0.7 Torr	5.5	15'	NA	NA	NA
	C	a										
	D	b										
	D	a										
4	C	b	300	34,700	5,500	off	0.2 Torr	5.5	30'	NA	NA	NA
	C	a										
	D	b										
	D	a										
5	C	b	150	34,700	3,300	on	0.8 Torr	5.5	15'	8	500	1,200
	C	a										
	D	b										
	D	a										
6	C	b	300	20,700	3,300	on	0.8 Torr	5.5	15'	16	0	2,000
	C	a										
	D	b										
	D	a										
7	C	b	600	34,700	3,300	off	0.8 Torr	4	30'	NA	NA	NA
	C	a										
	D	b										
	D	a										
8	C	b	600	34,700	5,500	off	0.8 Torr	4	30'	NA	NA	NA
	C	a										
	D	b										
	D	a										

TABLE 6

Expt. No.	Battery		Load Voltage	Watts/cell	Hr. left	Total kWh	Δ kWh		rel. kWh/h		net kWh/h	B. Eff.
	Pack	Position					gain	loss	gain	loss		
1	C	s	335.7	4.445	4	0.516					3.014	776%
	C	e	357.5	5.05	12	1.757	1.241		3.46			
	D	s	568.0	3.20	13	1.766						
	D	e	564.6	3.175	11	1.606		0.16	0.446			
2	C	s	315.5	3.93	1	0.114					1.012	504%
	C	e	327.8	4.25	4.5	0.502	0.387		1.225			
	D	s	540.7	2.91	4	0.535						
	D	e	535.3	2.87	3.5	0.462		0.073	0.243			
3	C	s	328	4.23	2	0.245					1.175	703%
	C	e	351.7	4.91	7	0.737	0.492		1.370			
	D	s	546	2.95	5	0.680						
	D	s	545.5	2.90	4.5	0.610		0.070	0.195			

TABLE 7

1 Expt. No.	2 Config.	3 Pressure Torr	4 Tube	5 DP DCV	6 Plates DCV	7 DP DCA	8 DP Watts	9 PAGD Volts	10 PAGD V/cm	11 CP DCV
1	dd	0.8	A29	562	350	0.65	137.8	212	77.1	375
2	dd	0.09	A29	562	402	0.60	96	160	58.2	378
3	dd	0.8	A29	560	371	0.59	111.5	189	68.7	374
4	dd	0.09	A29	563	409	0.49	75.9	154	56	379
5	t	1.5	A28	561	439	0.41	49.9	122	22.2	377
6	t	1.5	A28	560	425	0.51	68.9	135	24.5	375
7	t	1.0	A28	556	398	0.48	75	158	28.7	376.5
8	t	0.5	A28	559.5	398	0.68	109.8	161.5	29.4	377.5
9	t	0.5	A28	563	390	0.75	112.45	173	31.5	373
10	sd	0.5	A28	565	422	0.47	67.2	143	26	376
11	sd	0.5	A28	561.5	415	0.50	73	146.5	26.6	380
12	sd	0.5	A28	562	413.5	0.55	81.7	148.5	27	380
13	dd	0.25	A28	553	438	0.35	40	115	41.8	381.5
14	dd	0.25	A28	549	325	0.70	156.8	224	81.5	263

1 Expt. No.	2 Config.	12 CP DCA	13 CP Watts	14 Total Resistance	15 Breakeven Efficiency	16 PPS	17 Bridge diode	18 Input diode	19 Motor status	20 FIG. 3
1	dd	1.25	468.8	326	340%	450	M860	HFR	off	+
2	dd	0.70	264.6	% 270	276%	92	M860	HFR	off	
3	dd	0.65	243.1	243	218%	500	HFR	HFR	off	
4	dd	0.76	288	314	379%	77	HFR	HFR	off	
5	t	0.58	219	298	439%	52	HFR	HFR	off	
6	t	0.69	259	265	376%	100	M860	HFR	off	
7	t	0.57	213.1	329	284%	355	M860	HFR	off	
8	t	0.67	252.9	238	230%	92	HFR	HFR	off	
9	t	0.65	280	266	249%	118	M860	HFR	off	+
10	sd	1.03	387.3	286	530%	25	M860	HFR	off	
11	sd	0.73	277.4	293	379%	11	HFR	HFR	off	+
12	sd	0.71	269.8	270	330%	10	HFR	HFR	on	+
13	dd	0.59	225.1	329	563%	10	HFR	HFR	off	
14	dd	1.36	257.7	320	228%	1	HFR	HFR	off	

TABLE 8

1 Expt. No.	2 Battery Pack	3 Position	4 Total Wh	5 Rel. Cap.	6 Torr	7 Limit in W	8 ΔkWh		9 Exptl. time	10 abs. kWh/h			11 BE		
							gain	loss		gain	loss	net			
1	C	b	159	12%	0.8	90			21.5'			+664	846%		
	C	a	428	32%											
	D	b	1764	85%						269					753
2	D	a	1732	84%	0.8	90		32	18'		89	+616	2,667%		
	C	b	118	9%											
	C	a	303.5	23%						192					640
3	D	b	542.3	26%	0.2	90			70'			+186	3485%		
	D	a	535	25.9%							7.3				24
	C	b	950.4	72%						210.9					191.7
4	D	a	660	32%	0.8	90			64.5'		5.6	+53.7	406%		
	C	b	654	32%							6.5				
	C	a	15.8	1.2%						65					60
5	D	b	181	8.7%	0.8	90			28.5'		14.7	+169.1	436%		
	D	a	165	8%							16				
	C	b	34.5	2.6%											
6	C	a	138.8	10.5%	0.8	90			74'			+117	483%		
	D	b	1,114	54%						104.3					219.6
	D	a	1,089	53%							24				50.5
6	C	b	55.4	4.2%	0.8	90									
	C	a	237.6	18%						182.2					148
	D	b	669.3	32%											
	D	a	631.7	30.6%				37.7			30.6				

1 Expt. No.	2 Battery Pack	3 Position	12 Config.	13 Tube	14 Cathode area	15 gap cm	16 PPS	17 PAGD seq. method	18 R1 ohms	19 Plate material	21 C3/C5 mfd	22 C7a/C7b mfd
1	C	b	Triode	A26	128 cm ²	5.5	8	Continuous	300	H34	20,700	3,300
	C	a										
	D	b										
2	D	a	Triode	A26	128 cm ²	5.5	61	Interrupted	300	H34	20,700	3,300
	C	b										
	C	a										
3	D	b	Triode	A28	128 cm ²	5.5	32	Interrupted	300	H220	34,700	5,500
	C	a										
	D	b										
4	D	a	Triode	A46	64 cm ²	4.0	5	Continuous	600	H34	34,700	5,500
	C	b										
	C	a										
5	D	b	Triode	A46	64 cm ²	4.0	32	Interrupted	600	H34	34,700	5,500
	C	a										
	D	b										
6	D	a	Plate Diode	A29	128 cm ²	5.5	8	Interrupted	300	H220	34,700	5,500
	C	b										
	C	a										
	D	b										
	D	a										

TABLE 9

Utilizing: Al H200, 128 cm² plates
 DP = 46 cells
 CP = 23 cells

	PPS	CP Gain per pulse in mWh	Net Gain per pulse mWh	CP Gain per second mWh	Net Gain per second mWh	Pressure in Torr
#1	1.5	22.3	11.7	33.45	17.55	0.2
#2	8	5.6	4.4	44.8	35.2	0.8
#3	110	0.78	0.27	85.8	29.7	2.0

CLAIMS

1. Apparatus comprising a discharge tube and an electrical circuit containing said discharge tube and configured to operate the latter to provide endogenous pulsatory cold cathode auto-electronic emissions, the circuit being double ported with an input port connected to a source of direct current at a potential sufficient to initiate said emissions, and an output port connected to a current sink effective to absorb at least a substantial portion of electrical energy released by collapse of said emissions.
2. Apparatus according to claim 1 configured so that the emissions occur in a pulsed abnormal glow discharge regime.
3. Apparatus according to claim 2, wherein the input port includes components ensuring that the flow of current therein is unidirectional, and incorporating impedance sufficient to limit the flow of current therein.
4. Apparatus according to claim 2, including capacitors connected to the discharge tube, the input port and the output port, which provide charge storage in the input port and direct current isolation between the input and output ports.
5. Apparatus according to claim 4, wherein the output port comprises a rectifier having an input connected to said capacitors, reservoir capacitance connected to the output of said rectifier, and reverse current blocking devices connected between said reservoir capacitance and the current sink.
6. Apparatus according to claim 5, wherein the rectifier is a bridge rectifier, and the reservoir capacitance is provided by a capacitor bridge having ends connected to outputs of the bridge rectifier, and an intermediate point connected to one input of the bridge rectifier.
7. Apparatus according to claim 4, further including an alternating current motor and a capacitor in series, connected between the connections of said capacitors to the output port.
8. Apparatus according to claim 2, wherein the current sink comprises a secondary battery.
9. Apparatus according to claim 2, wherein the current sink comprises an electric motor.
10. Apparatus according to claim 2, wherein the direct current source comprises a secondary battery.
11. Apparatus according to claim 2, wherein the direct current source is a DC generator.
12. Apparatus according to claim 9, wherein the motor is a DC motor.
13. Apparatus according to claim 10, including a circuit for charging from the output port a battery to be used as the direct current source.
14. Apparatus according to claim 2, wherein the direct current source is a rectified AC source.
15. Apparatus according to claim 2, wherein the discharge tube is connected as a single diode.
16. Apparatus according to claim 2, wherein the discharge tube is connected as a multiple diode with plates connected as cathodes and an intermediate electrode connected as an anode.
17. Apparatus according to claim 2, wherein the discharge tube is connected as a triode, with an intermediate electrode functioning as an auxiliary cathode.
18. Apparatus according to claim 2, wherein a first potential is applied to the input port by the source of direct current to induce emission, a back EMF is applied to the output port by the current sink, and an extinction potential of the emissions is greater than the back EMF.
19. A method of energy conversion, comprising initiating plasma eruptions from the cathode of a discharge tube operating in a pulsed abnormal glow discharge regime utilising electrical energy from a source in a first circuit connected to said discharge tube, and capturing electrical energy generated by the collapse of such eruptions in a second circuit connected to said discharge tube.

20. A method according to claim 19, wherein current flowing into the discharge tube during said eruptions is at least 50 ma.
21. A method according to claim 19, wherein current flowing into the discharge tube during said eruptions is at least 500 ma.
22. A method according to claim 19, in which charge carriers within plasma outputs are accelerated through at least one of an electric and magnetic field.
23. A method of energy conversion, comprising inducing endogenous pulsatory low-field, large-area cold-cathode auto-electronic emissions from the cathode of a discharge tube capable of sustaining such emissions, utilising electrical energy from a source in a first circuit connected to said discharge tube, and capturing electrical energy generated by the collapse of such emissions in a second circuit connected to said discharge tube.

FRANKLIN MEAD AND JACK NACHAMKIN

Patent US 5,590,031 31st December 1996 Inventors: Franklin Mead & Jack Nachamkin

SYSTEM FOR CONVERTING ELECTROMAGNETIC RADIATION ENERGY TO ELECTRICAL ENERGY

This patent shows a system for converting Zero-Point Energy into conventional electrical power.

ABSTRACT

A system is disclosed for converting high-frequency zero-point electromagnetic radiation energy to electrical energy. The system includes a pair of dielectric structures which are positioned near each other and which receive incident zero-point electromagnetic radiation. The volumetric sizes of the structures are selected so that they resonate at a frequency of the incident radiation. The volumetric sizes of the structures are also slightly different so that the secondary radiation emitted from them at resonance, interferes with each other producing a beat frequency radiation which is at a much lower frequency than that of the incident radiation and which is amenable to conversion to electrical energy. An antenna receives the beat frequency radiation. The beat frequency radiation from the antenna is transmitted to a converter via a conductor or waveguide and converted to electrical energy having a desired voltage and waveform.

US Patent References:

3882503	May., 1975	Gamara	343/100.
4725847	Feb., 1988	Poirier	343/840.
5008677	Apr., 1991	Trigon et al.	342/17.

DESCRIPTION

BACKGROUND OF THE INVENTION

The invention relates generally to conversion of electromagnetic radiation energy to electrical energy, and, more particularly, to conversion of high frequency bandwidths of the spectrum of a type of radiation known as 'zero-point electromagnetic radiation' to electrical energy.

The existence of zero-point electromagnetic radiation was discovered in 1958 by the Dutch physicist M. J. Sparnaay. Mr. Sparnaay continued the experiments carried out by Hendrik B. G. Casimir in 1948 which showed the existence of a force between two uncharged parallel plates which arose from electromagnetic radiation surrounding the plates in a vacuum. Mr. Sparnaay discovered that the forces acting on the plates arose from not only thermal radiation but also from another type of radiation now known as classical electromagnetic zero-point radiation. Mr. Sparnaay determined that not only did the zero-point electromagnetic radiation exist in a vacuum but also that it persisted even at a temperature of absolute zero. Because it exists in a vacuum, zero-point radiation is homogeneous and isotropic as well as ubiquitous. In addition, since zero-point radiation is also invariant with respect to Lorentz transformation, the zero-point radiation spectrum has the characteristic that the intensity of the radiation at any frequency is proportional to the cube of that frequency. Consequently, the intensity of the radiation increases without limit as the frequency increases resulting in an infinite energy density for the radiation spectrum. With the introduction of the zero-point radiation into the classical electron theory, a vacuum at a temperature of absolute zero is no longer considered empty of all electromagnetic fields. Instead, the vacuum is now considered as filled with randomly fluctuating fields having the zero-point radiation spectrum. The special characteristics of the zero-point radiation which are that it has a virtually infinite energy density and that it is ubiquitous (even present in outer space) make it very desirable as an energy source. However, because high energy densities exist at very high radiation frequencies and because conventional methods are only able to convert or extract energy effectively or efficiently only at lower frequencies at which zero-point radiation has relatively low energy densities, effectively tapping this energy source has been believed to be unavailable using conventional techniques for converting electromagnetic energy to electrical or other forms of easily usable energy. Consequently, zero-point electromagnetic radiation energy which may potentially be used to power interplanetary craft as well as provide for society's other needs has remained unharnessed.

There are many types of prior art systems which use a plurality of antennas to receive electromagnetic radiation and provide an electrical output from them. An example of such a prior art system is disclosed in U.S. Pat. No.

3,882,503 to Gamara. The Gamara system has two antenna structures which work in tandem and which oscillate by means of a motor attached to them in order to modulate the radiation reflected from the antenna surfaces. The reflecting surfaces of the antennas are also separated by a distance equal to a quarter wavelength of the incident radiation. However, the Gamara system does not convert the incident radiation to electrical current for the purpose of converting the incident electromagnetic radiation to another form of readily usable energy. In addition, the relatively large size of the Gamara system components make it unable to resonate at and modulate very high frequency radiation.

What is therefore needed is a system which is capable of converting high frequency electromagnetic radiation energy into another form of energy which can be more readily used to provide power for transportation, heating, cooling as well as various other needs of society. What is also needed is such a system which may be used to provide energy from any location on earth or in space.

SUMMARY OF THE INVENTION

It is a principle object of the present invention to provide a system for converting electromagnetic radiation energy to electrical energy.

It is another object of the present invention to provide a system for converting electromagnetic radiation energy having a high frequency to electrical energy.

It is another object of the present invention to provide a system for converting zero-point electromagnetic radiation energy to electrical energy.

It is another object of the present invention to provide a system for converting electromagnetic radiation energy to electrical energy which may be used to provide such energy from any desired location on earth or in space.

It is another object of the present invention to provide a system for converting electromagnetic radiation energy to electrical energy having a desired waveform and voltage.

It is an object of the present invention to provide a miniaturised system for converting electromagnetic radiation energy to electrical energy in order to enhance effective utilisation of high energy densities of the electromagnetic radiation.

It is an object of the present invention to provide a system for converting electromagnetic radiation energy to electrical energy which is simple in construction for cost effectiveness and reliability of operation.

Essentially, the system of the present invention utilises a pair of structures for receiving incident electromagnetic radiation which may be propagating through a vacuum or any other medium in which the receiving structures may be suitably located. The system of the present invention is specifically designed to convert the energy of zero-point electromagnetic radiation; however, it may also be used to convert the energy of other types of electromagnetic radiation. The receiving structures are preferably composed of dielectric material in order to diffract and scatter the incident electromagnetic radiation. In addition, the receiving structures are of a volumetric size selected to enable the structures to resonate at a high frequency of the incident electromagnetic radiation based on the parameters of frequency of the incident radiation and propagation characteristics of the medium and of the receiving structures. Since zero-point radiation has the characteristic that its energy density increases as its frequency increases, greater amounts of electromagnetic energy are available at higher frequencies. Consequently, the size of the structures are preferably miniaturised in order to produce greater amounts of energy from a system located within a space or area of a given size. In this regard, the smaller the size of the receiving structures, the greater the amount of energy that can be produced by the system of the present invention.

At resonance, electromagnetically induced material deformations of the receiving structures produce secondary fields of electromagnetic energy therefrom which may have evanescent energy densities several times that of the incident radiation. The structures are of different sizes so that the secondary fields arising therefrom are of different frequencies. The difference in volumetric size is very small so that interference between the two emitted radiation fields, and the receiving structures at the two different frequencies produces a beat frequency radiation which has a much lower frequency than the incident radiation. The beat frequency radiation preferably is at a frequency which is sufficiently low that it may be relatively easily converted to usable electrical energy. In contrast, the incident zero-point radiation has its desirable high energy densities at frequencies which are so high that conventional systems for converting the radiation to electrical energy either cannot effectively or efficiently so convert the radiation energy or simply cannot be used to convert the radiation energy for other reasons.

The system of the present invention also includes an antenna which receives the beat frequency radiation. The antenna may be a conventional metallic antenna such as a loop or dipole type of antenna or a rf cavity structure

which partially encloses the receiving structures. The antenna feeds the radiation energy to an electrical conductor (in the case of a conventional dipole or comparable type of antenna) or to a waveguide (in the case of a rf cavity structure). The conductor or waveguide feeds the electrical current (in the case of the electrical conductor) or the electromagnetic radiation (in the case of the waveguide) to a converter which converts the received energy to useful electrical energy. The converter preferably includes a tuning circuit or comparable device so that it can effectively receive the beat frequency radiation. The converter may include a transformer to convert the energy to electrical current having a desired voltage. In addition, the converter may also include a rectifier to convert the energy to electrical current having a desired waveform.

BRIEF DESCRIPTION OF THE DRAWINGS

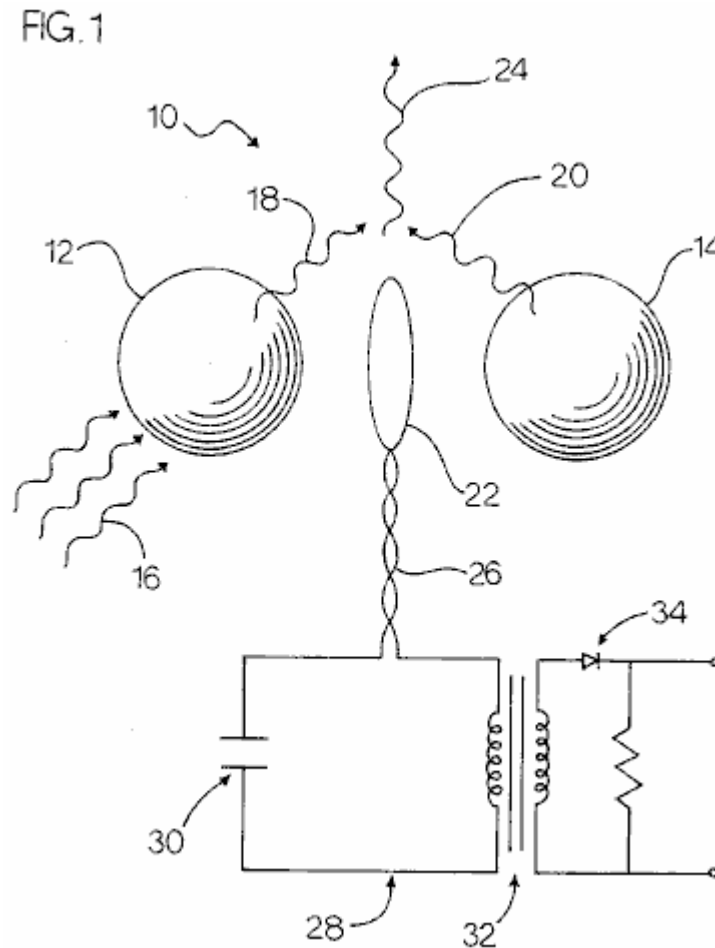

Fig.1 is a plan view of the receiving structures and antenna of a first embodiment of the system of the present invention with a schematic view of the conductor and converter thereof and also showing the incident primary and emitted secondary electromagnetic radiation.

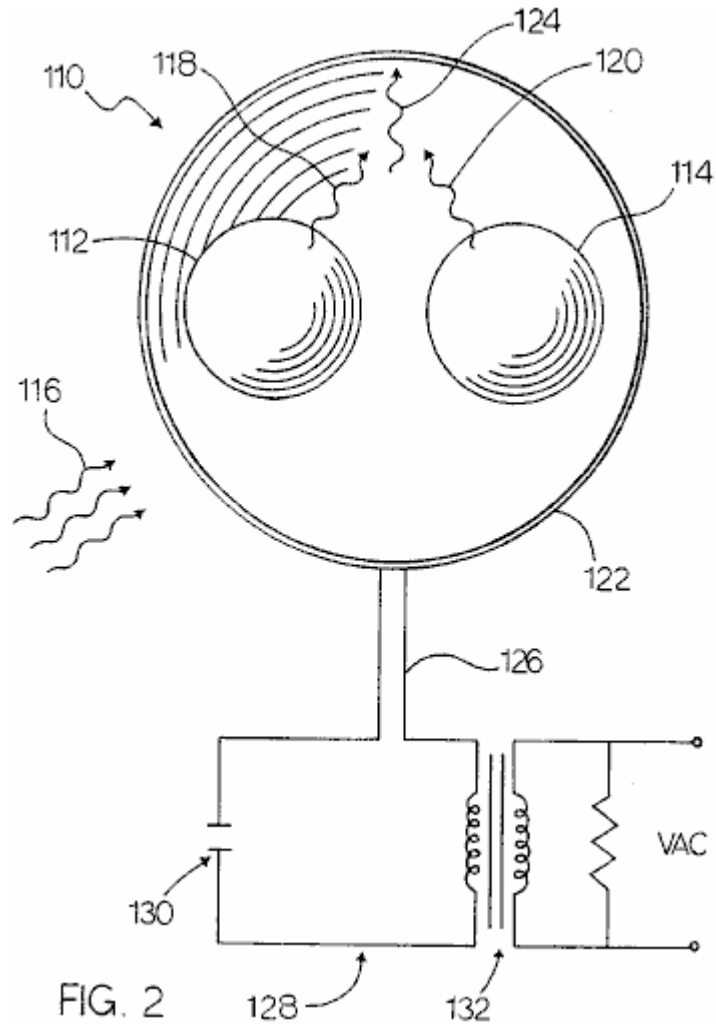

Fig.2 is a front view of the receiving structures, antenna and waveguide of a second embodiment of the system of the present invention with a schematic view of the converter thereof and also showing the incident primary and emitted secondary electromagnetic radiation.

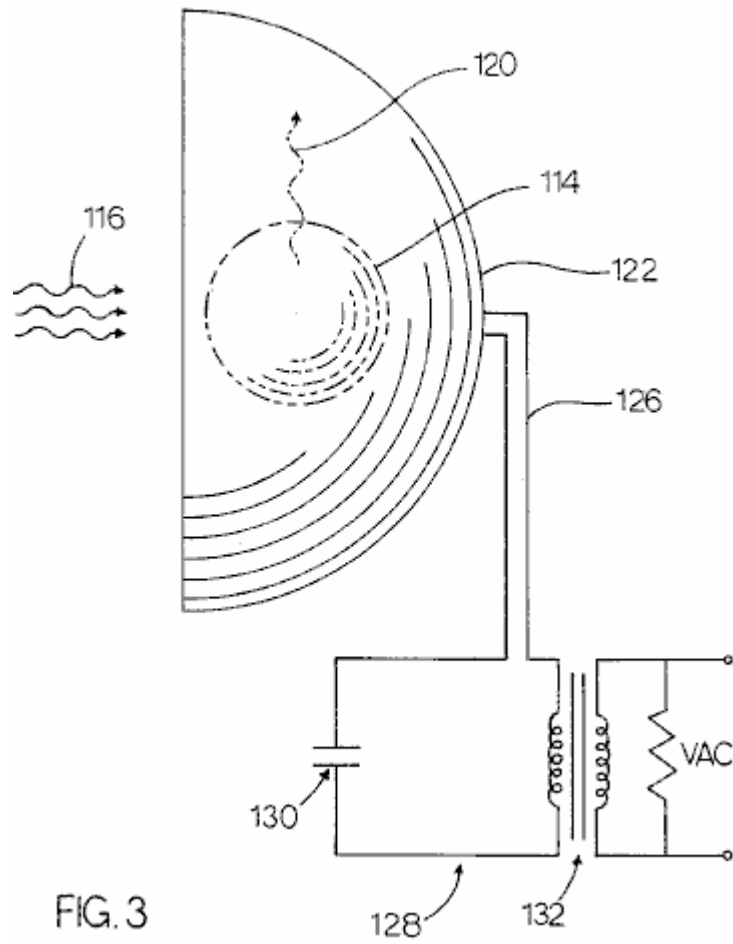

Fig.3 is a perspective view of the receiving structures, antenna and waveguide of the second embodiment shown in **Fig.2** with a schematic view of the converter thereof and also showing the incident primary and emitted secondary electromagnetic radiation.

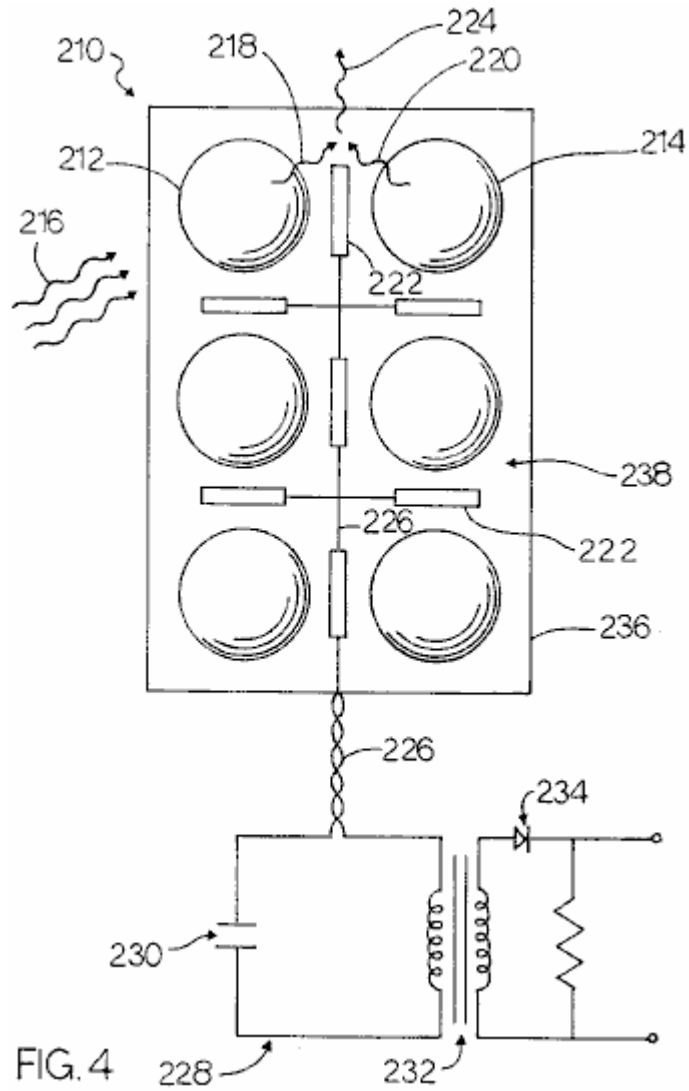

Fig.4 is a front view of the substrate and a plurality of pairs of the receiving structures and a plurality of antennas of a third embodiment of the system of the present invention with a schematic view of the conductor and converter thereof and also showing the incident primary and emitted secondary electromagnetic radiation.

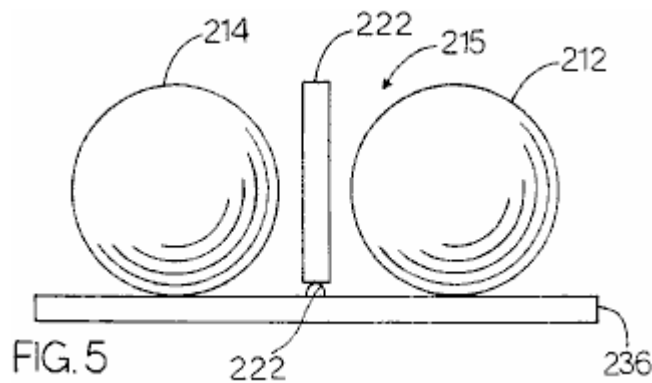

Fig.5 is a top view of some of the components of the third embodiment of the system of the present invention showing two of the plurality of pairs of receiving structures and two of the plurality of antennas mounted on the substrate.

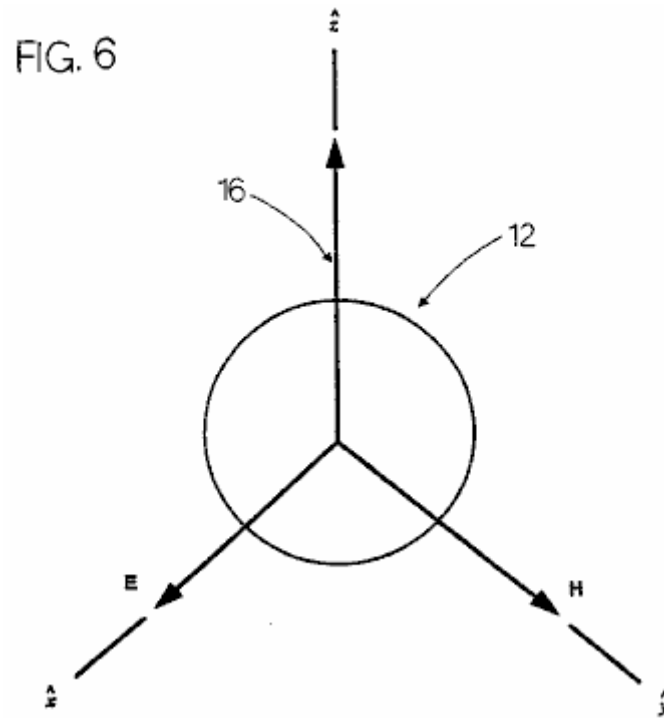

Fig.6 is a diagram of a receiving structure of the system of the present invention showing an incident electromagnetic plane wave impinging on the receiving structure and illustrating the directions of the electric and magnetic field vectors thereof.

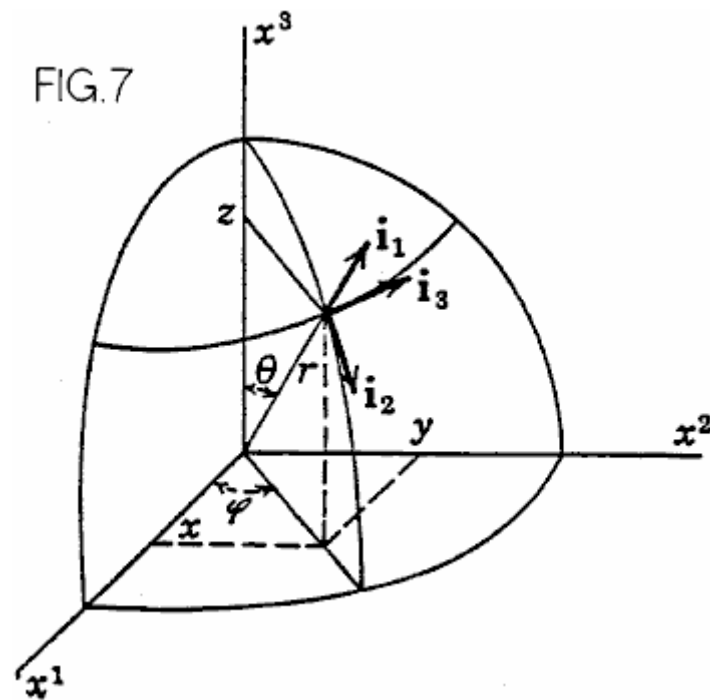

Fig.7 is a diagram of a spherical co-ordinate system as used in the formulas utilised in the system of the present invention.

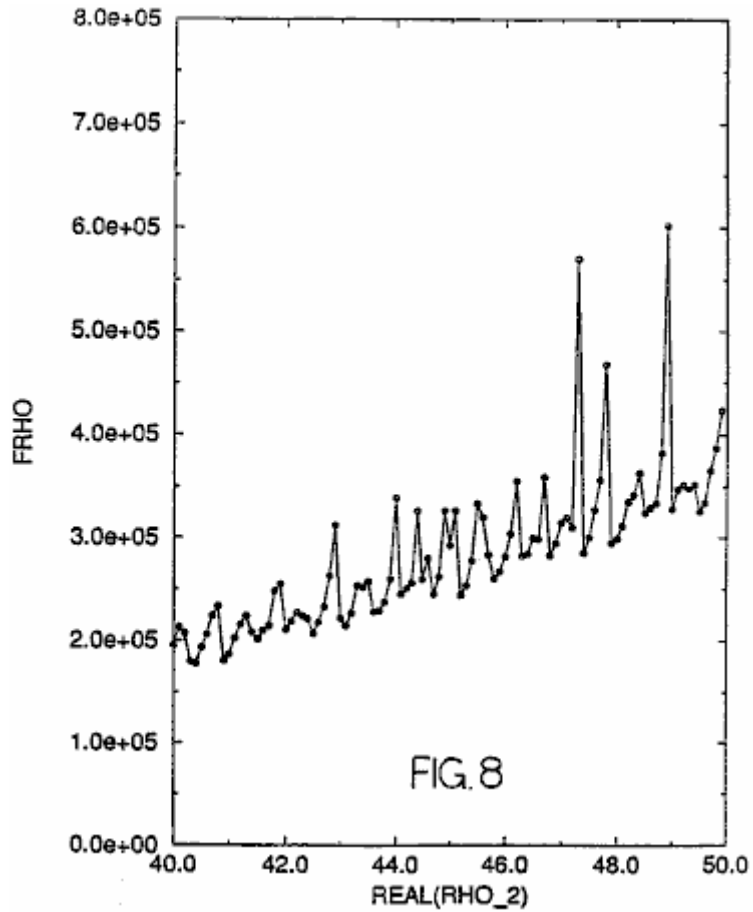

Fig.8 is a graph showing an imaginary rho parameter plotted against a real rho parameter illustrating the values thereof at resonance as well as values thereof at other than resonance.

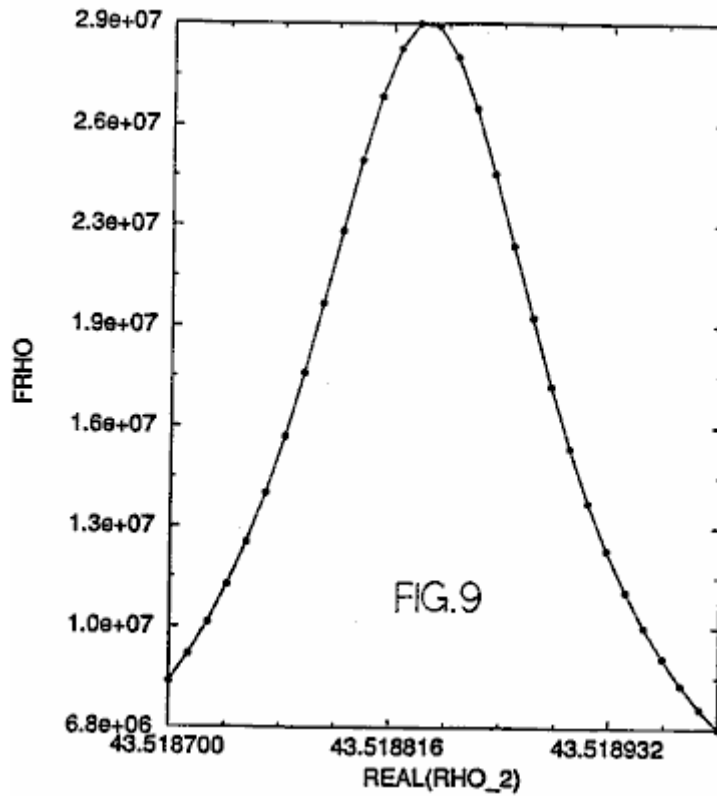

Fig.9 is a graph showing a portion of the graphical representation shown in **Fig.8** illustrating the real and imaginary rho values at or near a single resonance.

DETAILED DESCRIPTION OF THE PREFERRED EMBODIMENT

Referring to the drawings, a first embodiment of the present invention is generally designated by the numeral **10**. The system **10** includes a first and second means for receiving **12** and **14** incident electromagnetic radiation **16**. The means for receiving **12** and **14** are preferably a pair of spherical structures **12** and **14** which are preferably composed of a dielectric material. Alternatively, the spheres **12** and **14** may be cubical structures or any other suitable shape. The spheres **12** and **14** may be mounted on a suitable foundation by any suitable mounting means (not shown), or spheres **12** and **14** may be suspended from a suitable foundation by any suitable suspension means (not shown). The spheres **12** and **14** are preferably composed of a dielectric material. The dielectric spheres **12** and **14** scatter and concentrate electromagnetic waves. At very sharply defined frequencies, the spheres **12** and **14** will have resonances wherein the internal energy densities can be five orders of magnitude larger than the energy density of the incident electromagnetic field driving the spheres **12** and **14**. At resonance, the electromagnetic stresses, equivalent to pressures proportional to the energy density, can cause material deformation of the spheres **12** and **14** which produce a secondary electromagnetic field. The spheres **12** and **14** are preferably positioned proximal to each other, as shown in **Fig.1**. Although the proximity of the spheres to each other will adversely affect the resonances, the very high "Q"s of the isolated-sphere resonances results in such adverse affect being relatively small. However, the proximity of the spheres **12** and **14** allows the spheres to interact electromechanically which increases the magnitude of the secondary radiation emitted from them.

The electromagnetic radiation incident upon the spheres **12** and **14** which drives the spheres to resonance is preferably zero-point radiation **16**. However, other types of electromagnetic radiation may also be used to drive the spheres **12** and **14**, if desired.

The effect of a dielectric sphere such as **12** or **14** on an incident electromagnetic radiation such as a plane wave thereof is shown in **Fig.6**. The plane wave propagates in the z axis direction and is diffracted by the sphere **12** resulting in scattering thereof. This scattering is commonly known as Mie scattering. The incident radiation wave has an electric vector component which is linearly polarised in the x axis direction and a magnetic vector component which is linearly polarised in the y axis direction.

An electromagnetic wave incident upon a structure produces a forced oscillation of free and bound charges in synch with the primary electromagnetic field of the incident electromagnetic wave. The movements of the charges produce a secondary electromagnetic field both inside and outside the structure. The secondary electromagnetic radiation comprising this secondary electromagnetic field is shown in **Fig.1** and designated by the numerals **18** and **20**. An antenna which is shown simply as a loop antenna but may also be a dipole or any other suitable type of antenna, is also shown in **Fig.1** and designated by the numeral **22**. The non-linear mutual interactions of the spheres produces interference between the secondary electromagnetic radiation **18** and **20** produces a beat frequency radiation **24** which is preferably at a much lower frequency than the primary radiation **16**. It is this beat frequency radiation **24** which is desired for conversion into electrical energy because it preferably is within the frequency range of rf radiation which may be converted into electrical energy by generally conventional systems. Thus, the radiation **24** received by the antenna **22** is fed via an electrical conductor **26** to a means for converting the beat frequency radiation **24** to electrical energy. This means for converting is designated by the numeral **28** and preferably includes a tuning capacitor **30** and a transformer **32** and a rectifier (preferably a diode) **34**. Instead of including the capacitor **30**, transformer **32** and rectifier **34**, the converter **28** may alternatively include an rf receiver of any suitable type.

The resultant field at any point is the vector sum of the primary and secondary fields. For the equations that follow, the structure receiving the incident plane wave is a sphere of radius a having a propagation constant k_1 positioned in an infinite, homogeneous medium having a propagation constant k_2 . The incident plane wave propagates in the z axis direction and is as shown in **Fig.6**. The spherical co-ordinate system used for the vector spherical wave functions is shown in **Fig.7**.

Note: As this patent contains so many non-standard keyboard characters, the remainder of this document is produced using direct images of the original text.

Expansion of the incident field provides:

$$E_i = E_0 e^{-i\omega t} \sum_{n=1}^{\infty} i^n \frac{2n+1}{n(n+1)} (m_{01n}^{(1)} - i n_{21n}^{(1)})$$

$$H_i = -\frac{k_2}{\omega \mu_2} E_0 e^{-i\omega t} \sum_{n=1}^{\infty} i^n \frac{2n+1}{n(n+1)} (m_{21n}^{(1)} + i n_{01n}^{(1)})$$

where E is the electric field and H is the magnetic field; and

$$m_{01n}^{(1)} = \pm \frac{1}{\sin\theta} j_n(k_2 R) P_n^1(\cos\theta) \frac{\cos\phi_{i2} - j_n(k_2 R) \frac{\partial P_n^1}{\partial\theta} \frac{\sin\phi_{i3}}{\cos\phi_{i3}}}{\sin\phi_{i2} - j_n(k_2 R) \frac{\partial P_n^1}{\partial\theta} \frac{\sin\phi_{i3}}{\cos\phi_{i3}}}$$

$$n_{01n}^{(1)} = \frac{n(n+1)}{k_2 R} j_n(k_2 R) P_n^1(\cos\theta) \frac{\sin\phi_{i1}}{\cos\phi_{i1}} + \frac{1}{k_2 R} [k_2 R j_n(k_2 R)]' \times$$

$$\frac{\partial P_n^1}{\partial\theta} \frac{\sin\phi_{i2}}{\cos\phi_{i2}} \pm \frac{1}{k_2 R \sin\theta} [k_2 R j_n(k_2 R)]' P_n^1(\cos\theta) \frac{\cos\phi_{i3}}{\sin\phi_{i3}}.$$

The electric and magnetic fields of the incident wave transmitted into the sphere i.e., $R < a$, can be similarly expanded:

$$E_i = E_0 e^{-i\omega t} \sum_{n=1}^{\infty} i^n \frac{2n+1}{n(n+1)} \left(a_{01n}^{(1)} - i b_{e1n}^{(1)} \right)$$

$$H_i = \frac{k_2}{\phi \mu_1} E_0 e^{-i\omega t} \sum_{n=1}^{\infty} i^n \frac{2n+1}{n(n+1)} \left(b_{e1n}^{(1)} - i a_{01n}^{(1)} \right)$$

If $j_n(k_2 R)$ is replaced by $h_n^{(1)}(k_2 R)$ in the previous equations, the functions $m^{(1)}$ and $n^{(1)}$ become $m^{(3)}$ and $n^{(3)}$. The outgoing fields i.e., $R > a$, are represented by:

$$E_R = E_0 e^{-i\omega t} \sum_{n=1}^{\infty} i^n \frac{2n+1}{n(n+1)} \left(a_{01n}^{(3)} - i b_{e1n}^{(3)} \right)$$

$$H_r = \frac{k_2}{\phi \mu_1} E_0 e^{-i\omega t} \sum_{n=1}^{\infty} i^n \frac{2n+1}{n(n+1)} \left(b_{e1n}^{(3)} - i a_{01n}^{(3)} \right)$$

where H_r represents the resultant wave in the medium surrounding the sphere. At resonance, the values of ρ at resonance require that the a_n' and b_n' coefficients be infinite. In order to determine these values of a_n' and b_n' , the boundary conditions at the sphere radius are needed. Since there must be continuity of the E and H values at the surface, the following equations are used:

$$i_1 \times (E_i + E_r) = i_1 \times E_s \text{ and}$$

$$i_1 \times (H_i + H_r) = i_1 \times H_s$$

which lead to two pairs of inhomogeneous equations:

$$a_n' j_n(N\rho) - a_n' h_n^{(1)}(\rho) = j_n(\rho)$$

$$\mu_2 a_n' [N\rho j_n(N\rho)]' - \mu_1 a_n' [\rho h_n^{(1)}(\rho)]' = \mu_1 [\rho j_n(\rho)]' \text{ and}$$

$$\mu_2 N b_n' j_n(N\rho) - \mu_1 b_n' h_n^{(1)}(\rho) = \mu_1 j_n(\rho)$$

$$b_n' [N\rho j_n(N\rho)]' - N b_n' [\rho h_n^{(1)}(\rho)]' = N [\rho j_n(\rho)]'$$

where $k_1 = Nk_2$, $\rho = k_2 a$, $k_1 a = N\rho$. Spherical Bessel functions of the first kind are denoted by j_n , while those of the third kind are denoted by $h_n^{(1)}$. The resulting equations are:

$$a_n' = \frac{\mu_1 j_n(\rho) [\rho h_n^{(1)}(\rho)]' - \mu_1 h_n^{(1)}(\rho) [\rho j_n(\rho)]'}{\mu_1 j_n(N\rho) [\rho h_n^{(1)}(\rho)]' - \mu_2 h_n^{(1)}(\rho) [N\rho j_n(N\rho)]'}$$

and

$$b_n' = \frac{\mu_1 N j_n(\rho) [\rho h_n^{(1)}(\rho)]' - \mu_1 N h_n^{(1)}(\rho) [\rho j_n(\rho)]'}{\mu_2 N^2 j_n(N\rho) [\rho h_n^{(1)}(\rho)]' - \mu_1 h_n^{(1)}(\rho) [N\rho j_n(N\rho)]'}$$

At a resonance, the denominator of either a_n' or b_n' will be zero. Thus, ρ values are found using the above equations that correspond to a resonant combination of angular frequency (ω) and radius (a) for a given sphere material and given surrounding medium. In determining such values of ρ , the following equations are also specifically used:

$$\rho = ak_2 = a\omega \sqrt{\epsilon_2 \mu_2} \quad \text{and}$$

$$\rho_1 = (k_1/k_2)\rho$$

where ρ_1 corresponds to the sphere material. An iterative method is preferably used to find the desired values of ρ at resonance. In calculating ρ utilizing the above equations for purposes of example, it was assumed that $\mu_1 = \mu_2 = \mu_0 = 4\pi \times 10^{-7}$ and $\epsilon_2 = \epsilon_0 = 8.85419 \times 10^{-12}$.

One major root of ρ which was found has a value of:

$$\text{Real } (\rho) = +66.39752607619131$$

$$\text{Imaginary } (\rho) = -0.6347867071968998.$$

These particular values are not shown in FIG. 8. However, other values of ρ found using the equations set forth herein are shown in FIG. 8. The peaks in FIG. 8 are the resonances. One of these resonances shown in FIG. 8 is shown in detail in FIG. 9. These resonance values are shown for purposes of example. Other resonances also exist which have not been determined; thus, not all possible resonance values are shown in FIGS. 8 and 9.

Calculation of these values also allows the determination of a possible am combination which would have these root values. For ρ , ϵ (epsilon) = ϵ_0 and $\mu = \mu_0$, and

$$\rho = a\omega \sqrt{\epsilon_0 \mu_0} = a\omega/c.$$

Expressed in SI units, the speed of light $c = 2.99792458 \times 10^{14}$ m/s. If an a value of 10^{-6} m is assumed for the examples shown herein, then:

$$\omega = \rho c/a = 1.9919 \times 10^{16} - i1.9044 \times 10^{14} \text{ radians/s.}$$

This is an example of the angular frequency required within the impinging EM radiation in order to create a resonant situation. Examples of other resonances were indicated, and these are shown in FIG. 8. No complex-frequency plane waves exist. Therefore, the calculations were made by considering only the real portion of the above root and setting the imaginary portion equal to zero. However, upon

doing this, the iterative calculation procedure becomes insensitive to any root in the vicinity of the root's real portion. In the iterative calculation procedure, initially a range of ρ values is input into the equations. These ρ values are in the neighborhood of the prospective root. A range of ρ values is subsequently studied to find any imaginary ρ i.e., $f\rho$ (a function of ρ), peaks in that range. Next, once a peak has been chosen, the function order n giving the dominant $f\rho$ is determined. This also gives a clue as to whether the peak is due to a magnetic resonance (a_n approaches infinity) or an electrical resonance (b_n approaches infinity). A large number of Newton-Raphson iterations is preferably performed in order to converge upon a root ρ value.

FIGS. 2 and 3 show a second embodiment of the present invention generally designated by the numeral 110. Embodiment 110 is essentially the same as embodiment 10 except that the antenna is a rf cavity structure 122 which feeds the received beat frequency radiation 124 to a waveguide 126. Embodiment 110 also preferably includes two spheres 112 and 114 which receive the primary incident electromagnetic radiation 116 and emit the secondary electromagnetic radiation 118 and 120. As with the spheres 18 and 20 of embodiment 10, spheres 118 and 120 are preferably composed of a dielectric material. Embodiment 110 also includes converter 128, capacitor 130, transformer 132 and rectifier 134 which are essentially identical to the correspondingly numbered elements of embodiment 10. Therefore, a description of these components of embodiment 110 will not be repeated in order to promote brevity. In addition, the same equations and method of calculation set forth above with regard to embodiment 10 also apply to embodiment 110. Therefore, their description will not be repeated in order to promote brevity.

FIGS. 4 and 5 show a third embodiment of the present invention generally designated by numeral 210. Embodiment 210 is essentially identical to the first embodiment 10 except that the embodiment 210 includes a plurality of pairs 215 of receiving means (spheres) 212 and 214 mounted on a substrate 236. The spheres 212 and 214 are thus in the form of an array 238. The pairs 215 of the array 238 are preferably positioned proximal to each other in order to maximize the amount of energy extracted from a particular area or space of a given size. Since, as set forth hereinabove, the energy density of the zero point radiation increases as the frequency of the radiation increases, it is desirable that the spheres resonate at as high a bandwidth of frequencies as possible. Because the spheres 212 and 214 must be small in direct proportion to the wavelength of the high frequencies of the incident electromagnetic radiation 216 at which resonance is desirably obtained, the spheres 212 and 214 are preferably microscopic in size. Current lithographic techniques are capable of manufacturing such microscopically small spheres mounted on a suitable substrate thereby providing a suitably miniaturized system 210. A miniaturized system enhances the energy output capability of the system by

enabling it to resonate at higher frequencies at which there are correspondingly higher energy densities. Consequently, utilization of array 238 in the system 210 enhances the maximum amount of electrical energy provided by the system 210.

Lithographic techniques may be more amenable to manufacturing microscopically small receiving structures 212 and 214 which may be disc shaped, semispherical or have another shape other than as shown in FIGS. 4 and 5. Consequently, the receiving means 212 and 214 may accordingly have such alternative shapes rather than the spherical shape shown in FIGS. 4 and 5. In addition, a large number of small spheres may be manufactured by bulk chemical reactions. Packing a volume with such spheres in close proximity could enhance the output of energy.

Embodiment 210 also includes a plurality of antennas 222 positioned preferably between the spheres 212 and 214 which receive the beat frequency radiation 224 produced by the interference between the secondary radiation 218 and 220. The antennas 222 are shown as loop antennas 222 but may be any other suitable type of antennas as well.

Embodiment 210 has a plurality of electrical conductors 226 which preferably include traces mounted on the substrate 236 which occupies a finite volume. The electrical conductors 226 feed the electrical output from the antennas 222 to a suitable converter 228 which preferably includes tuning capacitor 230, transformer 232 and rectifier 234, as with embodiments 10 and 110. Except as set forth above, the components of embodiment 210 are identical to embodiment 10 so the detailed description of these components will not be repeated in order to promote brevity. In addition, the same equations and method of calculation set forth above for embodiment 10 also apply to embodiment 210. Therefore, the description of these equations and method of calculation will not be repeated in order to promote brevity.

Accordingly, there has been provided, in accordance with the invention, a system which converts high frequency zero point electromagnetic radiation into electrical energy effectively and efficiently and thus fully satisfies the objectives set forth above. It is to be understood that all terms used herein are descriptive rather than limiting. Although the invention has been specifically described with regard to the specific embodiments set forth herein, many alternative embodiments, modifications and variations will be apparent to those skilled in the art in light of the disclosure set forth herein. Accordingly, it is intended to include all such alternatives, embodiments, modifications and variations that fall within the spirit and scope of the invention as set forth in the claims hereinbelow.

What is claimed is:

1. A system for converting incident electromagnetic radiation energy to electrical energy, comprising:
 - a first means for receiving incident primary electromagnetic radiation, said means for receiving producing

emitted secondary electromagnetic radiation at a first frequency, said first means for receiving having a first volumetric size selected to resonate at a frequency within the frequency spectrum of the incident primary electromagnetic radiation in order to produce the secondary electromagnetic radiation at the first frequency at an enhanced energy density;

- a second means for receiving the incident primary electromagnetic radiation, said means for receiving producing emitted secondary electromagnetic radiation at a second frequency, the secondary radiation at the first frequency and the secondary radiation at the second frequency interfering to produce secondary radiation at a lower frequency than that of the incident primary radiation, said second means for receiving having a second volumetric size selected to resonate at a frequency within the frequency spectrum of the incident primary electromagnetic radiation in order to produce the emitted secondary electromagnetic radiation at the second frequency at an enhanced energy density;
- an antenna for receiving the emitted secondary electromagnetic radiation at the lower frequency, said antenna providing an electrical output responsive to the secondary electromagnetic radiation received;
- a converter electrically connected to said antenna for receiving electrical current output from said antenna and converting the electrical current output to electrical current having a desired voltage and waveform.

2. The system of claim 1 wherein:

said first means for receiving is composed of a dielectric material; and

said second means for receiving is composed of a dielectric material.

3. The system of claim 1 wherein:

said first means for receiving is spherical; and

said second means for receiving is spherical.

4. A system for for converting incident zero point electromagnetic radiation energy to electrical energy, comprising:

a first means for receiving incident primary zero point electromagnetic radiation, said means for receiving producing emitted secondary electromagnetic radiation at a first frequency;

a second means for receiving the incident primary zero point electromagnetic radiation, said means for receiving producing emitted secondary electromagnetic radiation at a second frequency, the secondary radiation at the first frequency and the secondary radiation at the second frequency interfering to produce secondary radiation at a beat frequency which is lower than that of the incident primary radiation;

an antenna for receiving the emitted secondary electromagnetic radiation at the lower frequency, said antenna providing an electrical output responsive to the secondary electromagnetic radiation received;

means for transmitting the emitted secondary electromagnetic radiation at the beat frequency from said antenna, said means for transmitting connected to said antenna;

a converter connected to said means for transmitting for receiving the emitted secondary electromagnetic radiation at the beat frequency from said antenna and converting the same to electrical current having a desired voltage and waveform.

5. The system of claim 4 wherein:

said first means for receiving has a first volumetric spherical size selected to resonate in response to the incident primary electromagnetic radiation in order to produce the secondary electromagnetic radiation at the first frequency at an enhanced energy density; and

said second means for receiving has a second volumetric spherical size selected to resonate in response to the incident primary electromagnetic radiation in order to produce the emitted secondary electromagnetic radiation at the second frequency at an enhanced energy density, said first and second volumetric sizes selected based on parameters of propagation constant of said first and second means for receiving, propagation constant of medium in which said first and second means for receiving are located and frequency of the incident primary electromagnetic radiation.

6. The system of claim 5 wherein the first and second volumetric sizes are selected by utilizing the formulas:

$$a_n^f = \frac{\mu_1 j_n(\rho) [\rho h_n^{(1)}(\rho)]' - \mu_1 h_n^{(1)}(\rho) [\rho j_n(\rho)]'}{\mu_1 j_n(N\rho) [\rho h_n^{(1)}(\rho)]' - \mu_2 h_n^{(1)}(\rho) [N\rho j_n(N\rho)]'}$$

$$b_n^f = \frac{\mu_1 N j_n(\rho) [\rho h_n^{(1)}(\rho)]' - \mu_1 N h_n^{(1)}(\rho) [\rho j_n(\rho)]'}{\mu_2 N^2 j_n(N\rho) [\rho h_n^{(1)}(\rho)]' - \mu_1 h_n^{(1)}(\rho) [N\rho j_n(N\rho)]'}$$

$$\rho = a\omega \sqrt{\epsilon_2 \mu_2}$$

wherein at a resonance, the denominator of either equation for a_n^f or b_n^f will be approximately zero and wherein k_1 =propagation constant of the means for receiving, k_2 =propagation constant of medium through which the incident electromagnetic radiation propagates, a is the radius of either means for receiving, $N=k_1/k_2$, $\rho=k_2 a$, $k_1 a=N\rho$, a_n^f =magnitude of oscillations of the electric field of the nth order, b_n^f =magnitude of oscillations of the magnetic field of the nth order, ω =angular frequency of the incident electromagnetic radiation, ϵ is the permittivity of the material or medium and μ is the permeability of the material or medium.

7. The system of claim 6 wherein the radius of the first means for receiving is different from the radius of the second means for receiving, difference between the radius of said first means for receiving and the radius of said second means for receiving selected so that the beat frequency resulting from the difference is a frequency which facilitates conversion of the beat frequency electromagnetic radiation to electrical energy.

8. The system of claim 4 wherein:

said first means for receiving is composed of a dielectric material; and

said second means for receiving is composed of a dielectric material.

9. The system of claim 4 wherein:

said first means for receiving is spherical; and

said second means for receiving is spherical.

10. The system of claim 4 wherein said antenna is positioned generally between said first and second means for receiving.

11. The system of claim 4 wherein said antenna is a loop antenna.

12. The system of claim 4 wherein said antenna is a generally concave shell partially enclosing said first and second means for receiving.

13. The system of claim 4 wherein said means for transmitting is a waveguide.

14. A system for for converting incident zero point electromagnetic radiation energy to electrical energy, comprising:

a substrate;

a plurality of pairs of first means for receiving incident primary zero point electromagnetic radiation and second means for receiving incident primary zero point electromagnetic radiation, said plurality of pairs of means for receiving mounted on said substrate, said first means for receiving producing emitted secondary electromagnetic radiation at a first frequency, said second means for receiving the incident primary zero point electromagnetic radiation producing emitted secondary electromagnetic radiation at a second frequency, the secondary radiation at the first frequency and the secondary radiation at the second frequency interfering to produce secondary radiation at a beat frequency which is lower than that of the incident primary radiation, said first means for receiving having a first volumetric size selected to resonate in response to the incident primary electromagnetic radiation in

order to produce the secondary electromagnetic radiation at the first frequency at an enhanced energy density, and said second means for receiving having a second volumetric size selected to resonate in response to the incident primary electromagnetic radiation in order to produce the emitted secondary electromagnetic radiation at the second frequency at an enhanced energy density, said first and second volumetric sizes selected based on parameters of propagation constant of said first and second means for receiving, propagation constant of medium in which said first and second means for receiving are located and frequency of the incident primary electromagnetic radiation, said first and second volumetric sizes being different from each other;

a plurality of antennas for receiving the emitted secondary electromagnetic radiation at the lower frequency, said antenna providing an output responsive to the secondary electromagnetic radiation received, said plurality of antennas mounted on said substrate, each of said plurality of antennas receiving the emitted secondary electromagnetic radiation of one of said pairs of first and second means for receiving;

means for transmitting the emitted secondary electromagnetic radiation at the beat frequency from said antenna, said means for transmitting connected to said plurality of antennas;

a converter connected to said means for transmitting for receiving the emitted secondary electromagnetic radiation at the beat frequency from said antenna and converting the same to electrical current having a desired voltage and waveform.

METHOD FOR THE PRODUCTION OF A FUEL GAS

Please note that this is a re-worded excerpt from this patent. It describes one of the methods which Stan used to split water into hydrogen and oxygen using very low levels of input power.

OBJECTS OF THE INVENTION

It is an object of the invention to provide a fuel cell and a process in which molecules of water are broken down into hydrogen and oxygen gases, and other formerly dissolved within the water is produced. As used herein the term "fuel cell" refers to a single unit of the invention comprising a water capacitor cell, as hereinafter explained, that produces the fuel gas in accordance with the method of the invention.

BRIEF DESCRIPTION OF THE DRAWINGS:

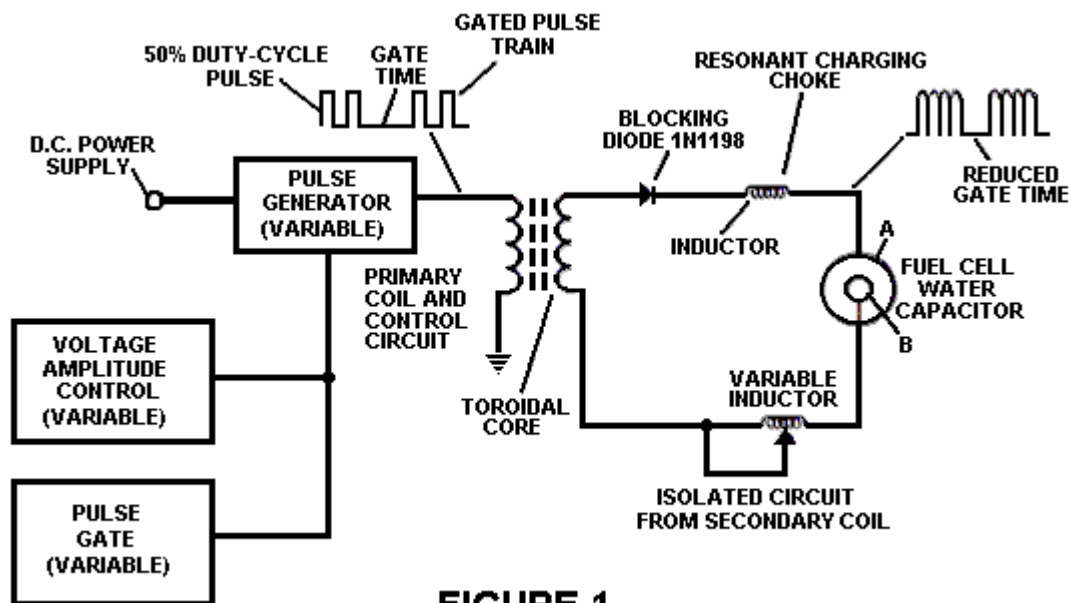

FIGURE 1

Fig.1 Illustrates a circuit useful in the process.

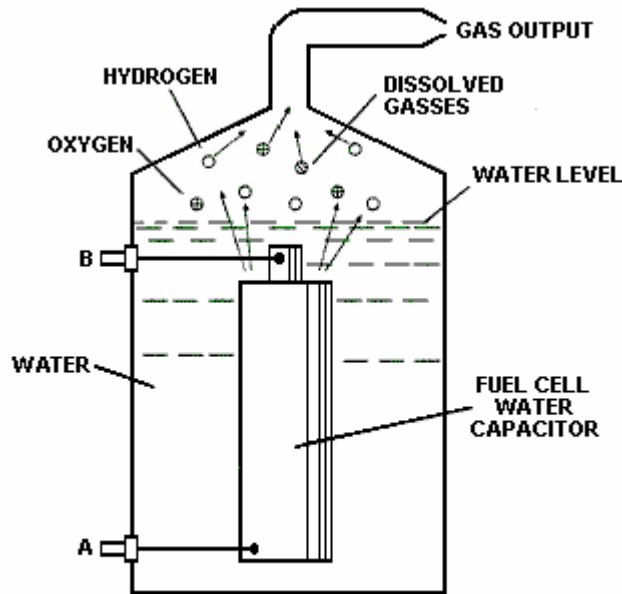

FIG 2

Fig.2 Shows a perspective of a "water capacitor" element used in the fuel cell circuit.

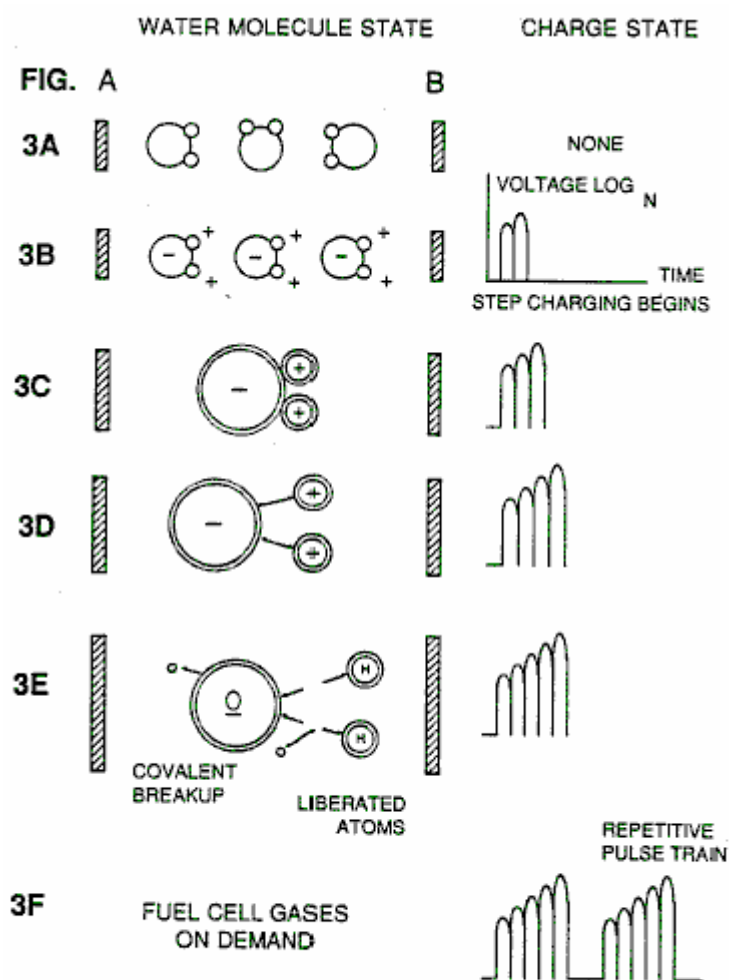

FIG. 3 (Parts A to F)

Figs. 3A through 3F are illustrations depicting the theoretical bases for the phenomena encountered during operation of the invention herein.

DESCRIPTION OF THE PREFERRED EMBODIEMENT

In brief, the invention is a method of obtaining the release of a gas mixture including hydrogen on oxygen and other dissolved gases formerly entrapped in water, from water consisting of:

- (a)** Providing a capacitor, in which the water is included as a dielectric liquid between capacitor plates, in a resonant charging choke circuit that includes an inductance in series with the capacitor;
- (b)** Subjecting the capacitor to a pulsating, unipolar electric voltage field in which the polarity does not pass beyond an arbitrary ground, whereby the water molecules within the capacitor are subjected to a charge of the same polarity and the water molecules are distended by their subjection to electrical polar forces;
- (c)** Further subjecting in said capacitor to said pulsating electric field to achieve a pulse frequency such that the pulsating electric field induces a resonance within the water molecule;
- (d)** Continuing the application of the pulsating frequency to the capacitor cell after resonance occurs so that the energy level within the molecule is increased in cascading incremental steps in proportion to the number of pulses;
- (e)** Maintaining the charge of said capacitor during the application of the pulsing field, whereby the co-valent electrical bonding of the hydrogen and oxygen atoms within said molecules is destabilised such that the force of the electrical field applied, as the force is effective within the molecule, exceeds the bonding force of the molecule, and hydrogen and oxygen atoms are liberated from the molecule as elemental gases; and
- (f)** Collecting said hydrogen and oxygen gases, and any other gases that were formerly dissolved within the water, and discharging the collected gases as a fuel gas mixture.

The process follows the sequence of steps shown in the following **Table 1** in which water molecules are subjected to increasing electrical forces. In an ambient state, randomly oriented water molecules are aligned with respect to a molecule polar orientation.

They are next, themselves polarised and "elongated" by the application of an electrical potential to the extent that covalent bonding of the water molecule is so weakened that the atoms dissociate and the molecule breaks down into hydrogen and oxygen elemental components.

Engineering design parameters based on known theoretical principles of electrical circuits determine the incremental levels of electrical and wave energy input required to produce resonance in the system whereby the fuel gas comprised of a mixture of hydrogen, oxygen, and other gases such as air were formerly dissolved within the water, is produced.

TABLE 1

Process Steps:

The sequence of the relative state of the water molecule and/or hydrogen/oxygen/other atoms:

- A.** (ambient state) random
 - B.** Alignment of polar fields
 - C.** Polarisation of molecule
 - D.** Molecular elongation
 - E.** Atom liberation by breakdown of covalent bond
 - F.** Release of gases
-

In the process, the point of optimum gas release is reached at a circuit resonance. Water in the fuel cell is subjected to a pulsating, polar electric field produced by the electrical circuit whereby the water molecules are distended by reason of their subjection to electrical polar forces of the capacitor plates. The polar pulsating frequency applied is such that the pulsating electric field induces a resonance in the molecule. A cascade effect occurs and the overall energy level of specific water molecules is increased in cascading, incremental steps. The hydrogen and oxygen atomic gases, and other gas components formerly entrapped as dissolved gases in water, are released when the resonant energy exceeds the covalent bonding force of the water molecule. A preferred construction material for the capacitor plates is T304-grade stainless steel which is non-chemical reactive with water, hydrogen, or oxygen. An electrically conductive material which is inert in the fluid environment is a desirable material of construction for the electrical field plates of the "water capacitor" employed in the circuit.

Once triggered, the gas output is controllable by the attenuation of operational parameters. Thus, once the frequency of resonance is identified, by varying the applied pulse voltage to the water fuel cell assembly, gas output is varied. By varying the pulse shape and/or amplitude or pulse train sequence of the initial pulsing wave source, final gas output is varied. Attenuation of the voltage field frequency in the form of OFF and ON pulses likewise affects output.

The overall apparatus thus includes an electrical circuit in which a water capacitor having a known dielectric property is an element. The fuel gases are obtained from the water by the disassociation of the water molecule. The water molecules are split into component atomic elements (hydrogen and oxygen gases) by a voltage stimulation process called the electrical polarisation process which also releases dissolved gases entrapped in the water.

From the outline of physical phenomena associated with the process described in **Table 1**, the theoretical basis of the invention considers the respective states of molecules and gases and ions derived from liquid water. Before voltage stimulation, water molecules are randomly dispersed throughout water in a container. When a unipolar voltage pulse train such as shown in **Figs.3B** through **3F** is applied to positive and negative capacitor plates, an increasing voltage potential is induced in the molecules in a linear, step like charging effect. The electrical field of the particles within a volume of water including the electrical field plates increases from a low energy state to a high energy state successively in a step manner following each pulse-train as illustrated figuratively in the depictions of **Figs.3A** through **3F**. The increasing voltage potential is always positive in direct relationship to negative ground potential during each pulse. The voltage polarity on the plates which create the voltage fields remains constant although the voltage charge increases. Positive and negative voltage "zones" are thus formed simultaneously in the electrical field of the capacitor plates.

In the first stage of the process described in **Table 1**, because the water molecule naturally exhibits opposite electrical fields in a relatively polar configuration (the two hydrogen atoms are positively electrically charged relative to the negative electrically charged oxygen atom), the voltage pulse causes initially randomly oriented water molecules in the liquid state to spin and orient themselves with reference to positive and negative poles of the voltage fields applied. The positive electrically charged hydrogen atoms of said water molecule are attracted to a negative voltage field; while, at the same time, the negative electrically charged oxygen atoms of the same water molecule are attracted to a positive voltage field. Even a slight potential difference applied to inert, conductive plates of a containment chamber which forms a capacitor will initiate polar atomic orientation within the water molecule based on polarity differences.

When the potential difference applied causes the orientated water molecules to align themselves between the conductive plates, pulsing causes the voltage field intensity to be increased in accordance with **Fig.3B**. As further molecule alignment occurs, molecular movement is hindered. Because the positively charged hydrogen atoms of said aligned molecules are attracted in a direction opposite to the negatively charged oxygen atoms, a polar charge alignment or distribution occurs within the molecules between said voltage zones, as shown in **Fig.3B**. And as the energy level of the atoms subjected to resonant pulsing increases, the stationary water molecules become elongated as shown in **Fig.3C** and **Fig.3D**. Electrically charged nuclei and electrons are attracted toward opposite electrically charged equilibrium of the water molecule.

As the water molecule is further exposed to an increasing potential difference resulting from the step charging of the capacitor, the electrical force of attraction of the atoms within the molecule to the capacitor plates of the chamber also increase in strength. As a result, the covalent bonding between which form the molecule is weakened --- and ultimately terminated. The negatively charged electron is attracted toward the positively charged hydrogen atoms, while at the same time, the negatively charged oxygen atoms repel electrons.

In a more specific explanation of the "sub-atomic" action that occurs in the water fuel cell, it is known that natural water is a liquid which has a dielectric constant of 78.54 at 20 degrees C. and 1 atmosphere pressure. [Handbook of Chemistry & Physics, 68th ed., CRC Press(Boca Raton, Florida (1987-88)), Section E-50. H₂O(water)].

When a volume of water is isolated and electrically conductive plates, that are chemically inert in water and are separated by a distance, are immersed in water, a capacitor is formed, having a capacitance determined by the surface area of the plates, the distance of their separation and the dielectric constant of water.

When water molecules are exposed to voltage at a restricted current, water takes on an electrical charge. By the laws of electrical attraction, molecules align according to positive and negative polarity fields of the molecule and the alignment field. The plates of the capacitor constitute such as alignment field when a voltage is applied.

When a charge is applied to a capacitor, the electrical charge of the capacitor equals the applied voltage charge; in a water capacitor, the dielectric property of water resists the flow of amps in the circuit, and the water molecule itself, because it has polarity fields formed by the relationship of hydrogen and oxygen in the covalent bond, and intrinsic dielectric property, becomes part of the electrical circuit, analogous to a "microcapacitor" within the capacitor defined by the plates.

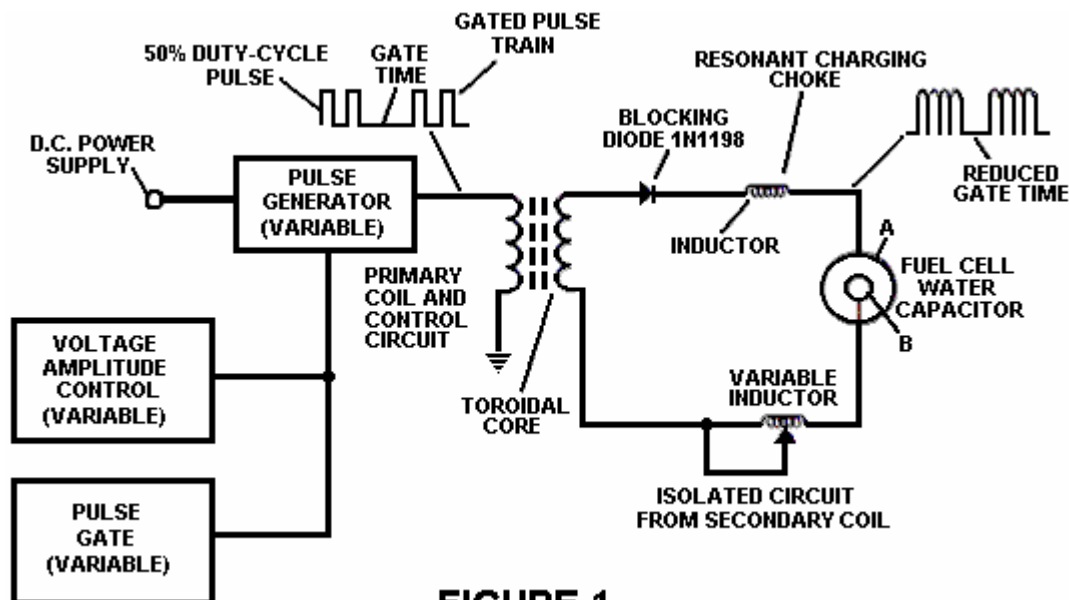

FIGURE 1

In the Example of a fuel cell circuit of **Fig.1**, a water capacitor is included. The step-up coil is formed on a conventional toroidal core formed of a compressed ferromagnetic powdered material that will not itself become permanently magnetised, such as the trademarked "Ferramic 06# "Permag" powder as described in Siemens Ferrites Catalogue, CG-2000-002-121, (Cleveland, Ohio) No. F626-1205". The core is 1.50 inch in diameter and 0.25 inch in thickness. A primary coil of 200 turns of 24 gauge copper wire is provided and coil of 600 turns of 36 gauge wire comprises the secondary winding.

In the circuit of **Fig.1**, the diode is a 1N1198 diode which acts as a blocking diode and an electric switch that allows voltage flow in one direction only. Thus, the capacitor is never subjected to a pulse of reverse polarity.

The primary coil of the toroid is subject to a 50% duty cycle pulse. The toroidal pulsing coil provides a voltage step-up from the pulse generator in excess of five times, although the relative amount of step-up is determined by preselected criteria for a particular application. As the stepped-up pulse enters first inductor (formed from 100 turns of 24 gauge wire 1 inch in diameter), an electromagnetic field is formed around the inductor, voltage is switched off when the pulse ends, and the field collapses and produces another pulse of the same polarity i.e., another positive pulse is formed where the 50% duty cycle was terminated. Thus, a double pulse frequency is produced; however, in pulse train of unipolar pulses, there is a brief time when pulses are not present.

By being so subjected to electrical pulses in the circuit of **Fig.1**, water confined in the volume that includes the capacitor plates takes on an electrical charge that is increased by a step charging phenomenon occurring in the water capacitor. Voltage continually increases (to about 1000 volts and more) and the water molecules starts to elongate.

The pulse train is then switched off; the voltage across the water capacitor drops to the amount of the charge that the water molecules have taken on, i.e., voltage is maintained across the charged capacitor. The pulse train is then reapplied.

Because a voltage potential applied to a capacitor can perform work, the higher the voltage the higher the voltage potential, the more work is performed by a given capacitor. In an optimum capacitor that is wholly non-conductive, zero (0) current flow will occur across the capacitor. Thus, in view of an idealised capacitor circuit, the object of the water capacitor circuit is to prevent electron flow through the circuit, i.e. such as occurs by electron flow or leakage through a resistive element that produces heat. Electrical leakage in the water will occur, however, because of some residual conductivity and impurities or ions that may be otherwise present in the water. Thus, the water capacitor is preferably chemically inert. An electrolyte is not added to the water.

In the isolated water bath, the water molecule takes on charge, and the charge increases. The object of the process is to switch off the covalent bonding of the water molecule and interrupt the subatomic force, i.e. the electrical force or electromagnetic force, that binds the hydrogen and oxygen atoms to form a molecule so that the hydrogen and oxygen separate.

Because an electron will only occupy a certain electron shell (shells are well known) the voltage applied to the capacitor affects the electrical forces inherent in the covalent bond. As a result of the charge applied by the plates, the applied force becomes greater than the force of the covalent bonds between the atom of the water molecule;

and the water molecule becomes elongated. When this happens, the time share ratio of the electron shells is modified.

In the process, electrons are extracted from the water bath; electrons are not consumed nor are electrons introduced into the water bath by the circuit as electrons are conventionally introduced in as electrolysis process. There may nevertheless occur a leakage current through the water. Those hydrogen atoms missing electrons become neutralised; atoms are liberated from the water. The charged atoms and electrons are attracted to the opposite polarity voltage zones created between the capacitor plates. The electrons formerly shared by atoms in the water covalent bond are reallocated such that neutral elemental gases are liberated.

In the process, the electrical resonance may be reached at all levels of voltage potential. The overall circuit is characterised as a "resonant charging choke" circuit which is an inductor in series with a capacitor that produces a resonant circuit. [SAMS Modern Dictionary of Electronics, Rudolf Garff, copyright 1984, Howard W. Sams & Co. (Indianapolis, Ind.), page 859.] Such a resonant charging choke is on each side of the capacitor. In the circuit, the diode acts as a switch that allows the magnetic field produced in the inductor to collapse, thereby doubling the pulse frequency and preventing the capacitor from discharging. In this manner a continuous voltage is produced across the capacitor plates in the water bath; and the capacitor does not discharge. The water molecules are thus subjected to a continuously charged field until the breakdown of the covalent bond occurs.

As noted initially, the capacitance depends on the dielectric properties of the water and the size and separation of the conductive elements forming the water capacitor.

EXAMPLE 1

In an example of the circuit of **Fig.1** (in which other circuit element specifications are provided above), two concentric cylinders 4 inches long formed the water capacitor of the fuel cell in the volume of water. The outside cylinder was 0.75 inch in outside diameter; the inner cylinder was 0.5 inch in outside diameter. Spacing from the outside of the inner cylinder to the inner surface of the outside cylinder was 0.0625 inch. Resonance in the circuit was achieved at a 26 volt applied pulse to the primary coil of the toroid at 0 KHz (*suspected mis-typing for 10KHz*), and the water molecules disassociated into elemental hydrogen and oxygen and the gas released from the fuel cell comprised a mixture of hydrogen, oxygen from the water molecule, and gases formerly dissolved in the water such as the atmospheric gases or oxygen, nitrogen, and argon.

In achieving resonance in any circuit, as the pulse frequency is adjusted, the flow of amps is minimised and the voltage is maximised to a peak. Calculation of the resonance frequency of an overall circuit is determined by known means; different cavities have a different frequency of resonance dependant on parameters of the water dielectric, plate size, configuration and distance, circuit inductors, and the like. Control of the production of fuel gas is determined by variation of the period of time between a train of pulses, pulse amplitude and capacitor plate size and configuration, with corresponding value adjustments to other circuit components.

The wiper arm on the second conductor tunes the circuit and accommodates to contaminants in water so that the charge is always applied to the capacitor. The voltage applied determines the rate of breakdown of the molecule into its atomic components. As water in the cell is consumed, it is replaced by any appropriate means or control system.

Variations of the process and apparatus may be evident to those skilled in the art.

CLAIMS:

1. A method of obtaining the release of a gas mixture including hydrogen and oxygen and other dissolved gases formerly entrapped in water, from water, consisting of:
 - (a) Providing a capacitor in which water is included as a dielectric between capacitor plates, in a resonant charging choke circuit that includes an inductance in series with the capacitor;
 - (b) Subjecting the capacitor to a pulsating, unipolar electric charging voltage in which the polarity does not pass beyond an arbitrary ground, whereby the water molecules within the capacitor plates;
 - (c) Further subjecting the water in said capacitor to a pulsating electric field resulting from the subjection of the capacitor to the charging voltage such that the pulsating electric field induces a resonance within the water molecules;
 - (d) Continuing the application of the pulsating charging voltage to the capacitor after the resonance occurs so that the energy level within the molecules is increased in cascading incremental steps in proportion to the number of pulses;
 - (e) Maintaining the charge of said capacitor during the application of the pulsating charge voltage, whereby the covalent electrical bonding of the hydrogen and oxygen atoms within said molecules is destabilised, such

that the force of the electrical field applied to the molecules exceeds the bonding force within the molecules, and the hydrogen and oxygen atoms are liberated from the molecules as elemental gases.

2. The method of claim 1 including the further steps of collecting said liberated gases and any other gases that were formerly dissolved within the water and discharging said collected gases as a fuel gas mixture.

STANLEY MEYER

US Patent 4,389,981

28th June 1983

Inventor: Stanley A. Meyer

HYDROGEN GAS INJECTOR SYSTEM FOR INTERNAL COMBUSTION ENGINES

Please note that this is a re-worded excerpt from this patent. It describes one method for using hydrogen and oxygen gases to fuel a standard vehicle engine.

ABSTRACT

System and apparatus for the controlled intermixing of a volatile hydrogen gas with oxygen and other non-combustible gasses in a combustion system. In a preferred arrangement the source of volatile gas is a hydrogen source, and the non-combustible gasses are the exhaust gasses of the combustion system in a closed loop arrangement. Specific structure for the controlled mixing of the gasses, the fuel flow control, and safety are disclosed.

CROSS REFERENCES AND BACKGROUND

There is disclosed in my co-pending U.S. patent application Serial No. 802,807 filed Sept. 16, 1981 for a Hydrogen-Generator, a generating system converting water into hydrogen and oxygen gasses. In that system and method the hydrogen atoms are dissociated from a water molecule by the application of a non-regulated, non-filtered, low-power, direct current voltage electrical potential applied to two non-oxidising similar metal plates having water passing between them. The sub-atomic action is enhanced by pulsing this DC voltage. The apparatus comprises structural configurations in alternative embodiments for segregating the generated hydrogen gas from the oxygen gas.

In my co-pending patent application filed May 5, 1981, U.S. Serial No. 262,744 now abandoned for Hydrogen-Airdation Processor, non-volatile and non-combustible gasses are controlled in a mixing stage with a volatile gas. The hydrogen airdation processor system utilises a rotational mechanical gas displacement system to transfer, meter, mix, and pressurise the various gasses. In the gas transformation process, ambient air is passed through an open flame gas-burner system to eliminate gasses and other substances present. After that, the non-combustible gas-mixture is cooled, filtered to remove impurities, and mechanically mixed with a pre-determined amount of hydrogen gas. This results in a new synthetic gas.

This synthetic gas-formation stage also measures the volume and determines the proper gas-mixing ratio for establishing the desired burn-rate of hydrogen gas. The rotational mechanical gas displacement system in that process determines the volume of synthetic gas to be produced.

The above-noted hydrogen airdation processor, of my co-pending application, is a multi-stage system suited to special applications. Whereas the hydrogen generator system of my other mentioned co-pending application does disclose a very simple and unique hydrogen generator.

In my co-pending patent application Serial No. 315,945, filed Oct. 18, 1981 there is disclosed a combustion system incorporating a mechanical drive system. In one instance, this is designed to drive a piston in an automotive device. There is shown a hydrogen generator for developing hydrogen gas, and perhaps other non-volatile gasses such as oxygen and nitrogen. The hydrogen gas with the attendant non-volatile gasses is fed via a line to a controlled air intake system. The combined hydrogen, non-volatile gasses, and the air, after inter-mixing, are fed to a combustion chamber where they are ignited. The exhaust gasses of the combustion chamber are returned in a closed loop arrangement to the mixing chamber to be used again as the non-combustible gas component. Particular applications and structural embodiments of the system are disclosed.

SUMMARY OF THE INVENTION

The system of the present invention in its most preferred embodiment is for a combustion system utilising hydrogen gas; particularly to drive the pistons in an car engine. The system utilises a hydrogen generator for developing hydrogen gas. The hydrogen gas and other non-volatile gasses are then fed, along with oxygen, to a mixing chamber. The mixture is controlled in such a way as to lower the temperature of the combustion to bring it in line with that of the currently existing commercial fuels. The hydrogen gas feed line to the combustion chamber includes a fine linear control gas flow valve. An air intake is the source of oxygen and it also includes a variable

valve. The exhaust gasses from the combustion chamber are utilised in a controlled manner as the non-combustible gasses.

The hydrogen generator is improved by the inclusion of a holding tank which provides a source of start-up fuel. Also, the hydrogen gas generator includes a pressure-controlled safety switch on the combustion chamber which disconnects the input power if the gas pressure rises above the required level. The simplified structure includes a series of one-way valves, safety valves, and quenching apparatus. The result is an apparatus which comprises the complete assembly for converting a standard car engine from petrol (or other fuels) to use a hydrogen/gas mixture.

OBJECTS

It is accordingly a principal object of the present invention to provide a combustion system of gasses combined from a source of hydrogen and non-combustible gasses.

Another object of the invention is to provide such a combustion system that intermixes the hydrogen and non-combustible gasses in a controlled manner and thereby control the combustion temperature.

A further object of the invention is to provide such a combustion system that controls the fuel flow to the combustion chamber in a system and apparatus particularly adapted to hydrogen gas.

Still other objects and features of the present invention will become apparent from the following detailed description when taken in conjunction with the drawings in which:

BRIEF DESCRIPTION OF THE DRAWINGS

Fig.1 is a mechanical schematic illustration partly in block form of the present invention in its most preferred embodiment.

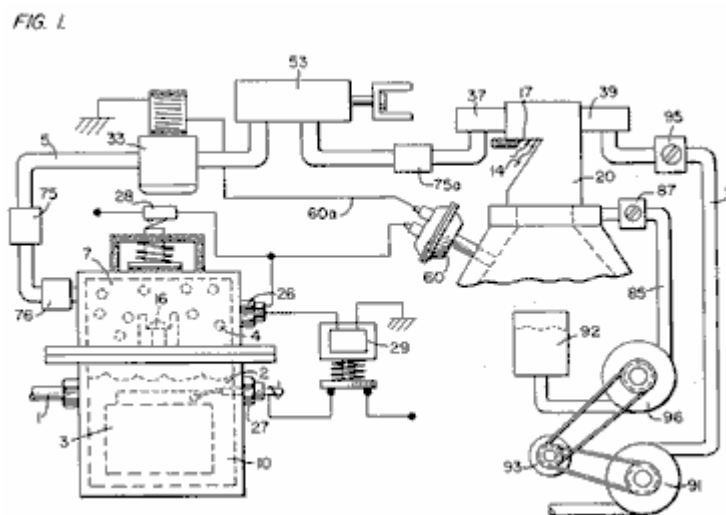

Fig.2 is a block schematic illustration of the preferred embodiment of the hydrogen injector system shown in Fig.1.

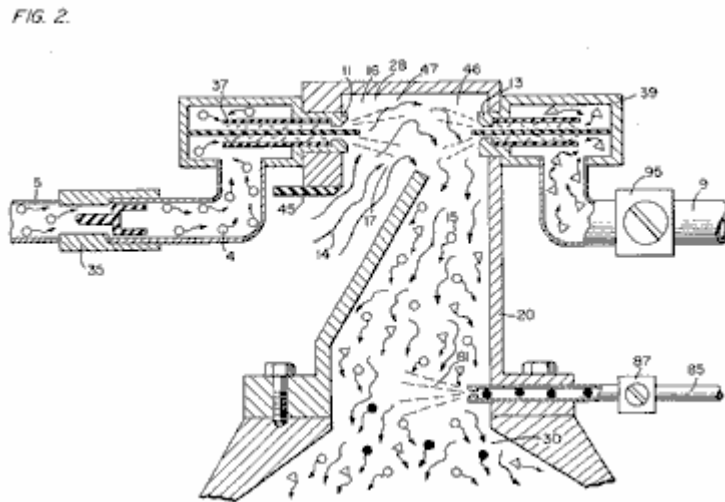

Fig.3 is the fine linear fuel flow control shown in Fig.1.

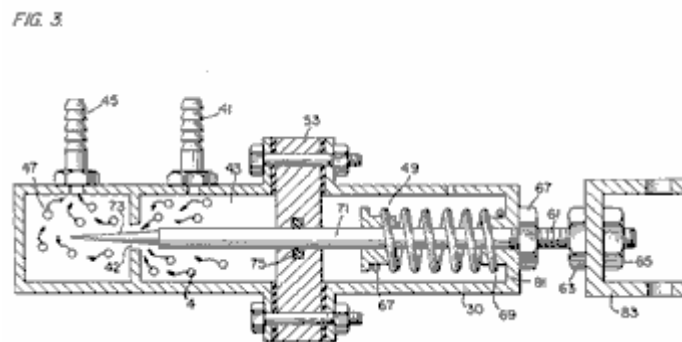

Fig.4 is cross-sectional illustration of the complete fuel injector system in an car utilising the concepts of the present invention.

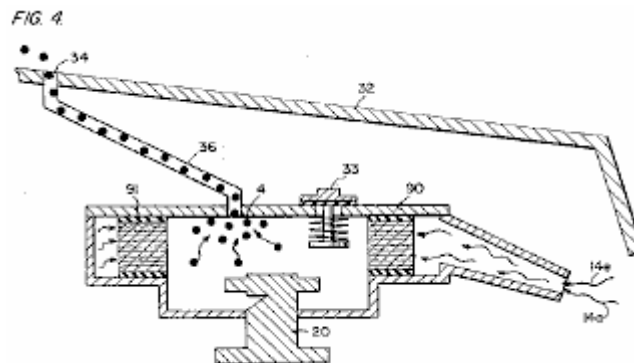

FIG. 8.

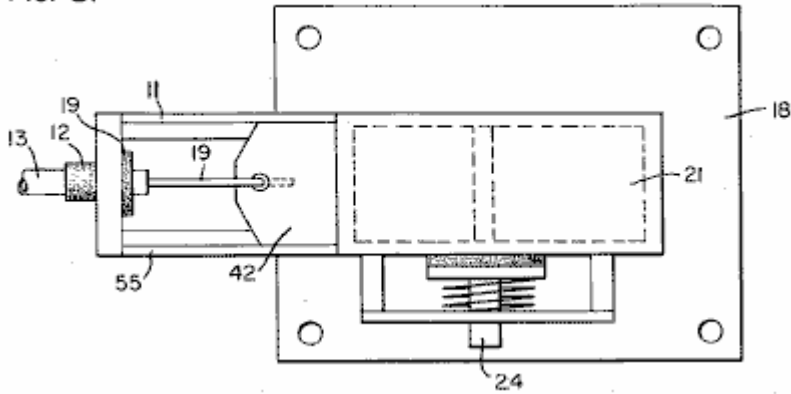
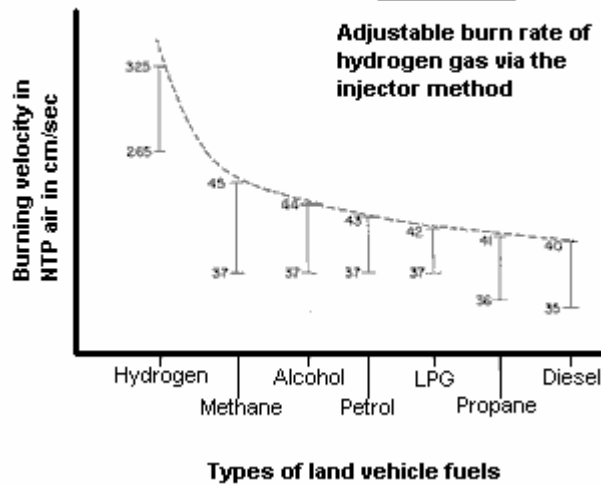

Fig.9 is a comparison of the burning velocity of hydrogen with respect to other fuels.

FIG 9

Appendix A

Adjustable burn rate of hydrogen gas via the injector method



DETAILED DESCRIPTION OF INVENTION TAKEN WITH DRAWINGS:

FIG. 1

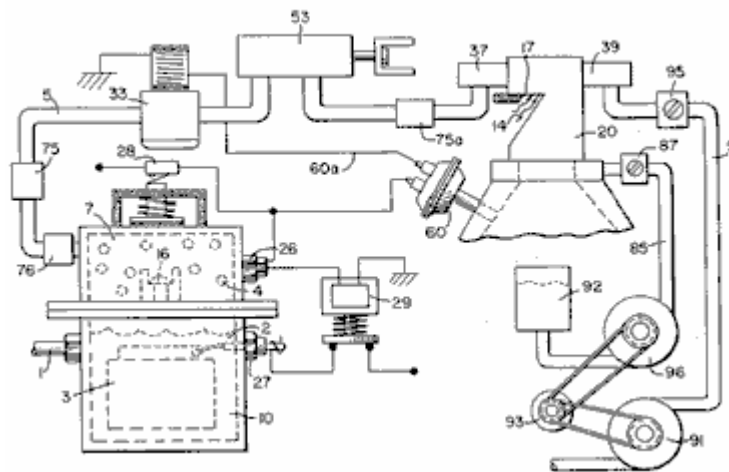

Referring to **Fig.1** the complete overall gas mixing and fuel flow system is illustrated together for utilisation in a combustion engine, particularly an engine in a car. With specific reference to **Fig.1**, the hydrogen source **10** is the hydrogen generator disclosed and described in my co-pending application, supra. The container **10** is an enclosure for a water bath **2**. Immersed in the water **2** is an array of plates **3** as further described in my co-pending application, supra. Applied to plates **3** is a source of direct current potential via electrical inlet **27**. The upper portion **7** of the container **10** is a hydrogen storage area maintaining a predetermined amount of pressure. In this way, there will be an immediate flow of hydrogen gas at start-up.

To replenish the expended water, the generator provides a continuous water source 1. Thereafter, the generator is operable as described in the aforesaid patent application. The safety valve 28 is designed to rupture should there be an excessive build-up of gas. Switch 26 is a gas-pressure switch included to maintain a predetermined gas pressure level about a regulated low-volume.

The generated hydrogen gas 4 is fed from the one-way check valve 16 via pipe 5 to a gas-mixing chamber 20, where the hydrogen gas is mixed with non-combustible gasses via pipe 9 from a source described later.

If the one-way valve 75 failed, there could be a return spark which could ignite the hydrogen gas 4 in the storage area 7 of the hydrogen generator 10. To prevent this, the quenching assembly 76 has been included to prevent just such an ignition.

FIG. 2.

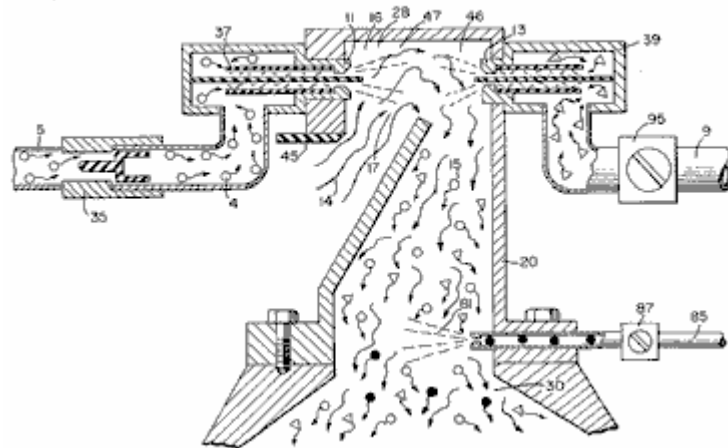

With particular reference to **Fig.2**, the hydrogen gas (via pipe 5) and non-combustible gasses (via pipe 9), are fed to a carburettor (air-mixture) system 20 also having an air intake 14 for ambient air.

The hydrogen gas 4 is fed via line 5 through nozzle 11 in a spray 16 in to the trap area 46 of the mixing chamber 20. Nozzle 11 has an opening smaller than the plate openings in the quenching assembly 37, thereby preventing flash-back in the event of sparking. The non-volatile gasses are injected into mixing chamber 20 trap area 47 in a jet spray 17 via nozzle 13. Quenching assembly 39 is operable much in the same manner as quenching assembly 37.

In the preferred arrangement, the ambient air is the source of oxygen necessary for the combustion of the hydrogen gas. Further, as disclosed in the aforesaid co-pending application, the non-volatile gasses are in fact, the exhaust gasses passed back via a closed loop system. It is to be understood that the oxygen and/or the non-combustible gasses might also be provided from an independent source.

With continued reference to **Fig.2** the gas trap area 47 is a predetermined size. As hydrogen is lighter than air, the hydrogen will rise and become trapped in area 47. Area 47 is large enough to contain enough hydrogen gas to allow instant ignition upon the subsequent start-up of the combustion engine.

It will be noted that the hydrogen gas is injected in the uppermost region of the trap area 47. Hydrogen rises at a much greater rate than oxygen or the non-combustible gasses; perhaps three times or greater. Therefore, if the hydrogen gas entered the trap area 47 (mixing area) at its lowermost region the hydrogen gas would rise so rapidly that the air could not mix with the oxygen. With the trap area 47 shown in **Fig.2**, the hydrogen is forced downwards into the air intake 15. That is, the hydrogen gas is forced downwards into the upwardly forced air and this causes adequate mixing of the gasses.

The ratio of the ambient air (oxygen) 14 and the non-combustible gas via line 9 is a controlled ratio which is tailored to the particular engine. Once the proper combustion rate has been determined by the adjustment of valve 95 (for varying the amount of the non-combustible gas) and the adjustment of valve 45 (for varying the amount of the ambient air), the ratio is maintained thereafter.

In a system where the non-combustible gasses are the exhaust gasses of the engine itself, passed back through a closed loop-arrangement, and where the air intake is controlled by the engine, the flow velocity and hence the air/non-combustible mixture, is maintained by the acceleration of the engine.

The mixture of air with non-combustible gasses becomes the carrier for the hydrogen gas. That is, the hydrogen gas is mixed with the air/non-combustible gas mixture. By varying the amount of hydrogen gas added to the air/non-combustible mixture, the engine speed is controlled.

FIG. 3.

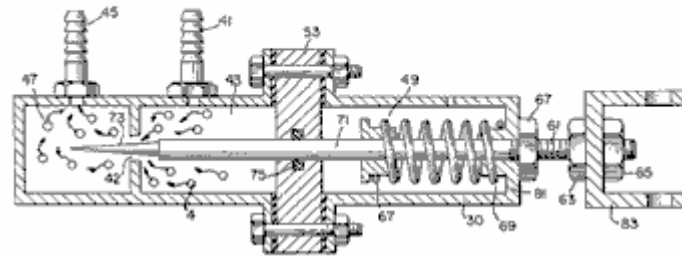

Reference is made to **Fig.3** which shows in a side view cross-section, the fine linear fuel flow control **53**. The hydrogen gas **4** enters chamber **43** via gas inlet **41**. The hydrogen gas passes from chamber **43** to chamber **47** via port or opening **42**. The amount of gas passing from chamber **43** to chamber **47** is dictated by the setting of the port opening **42**.

The port opening is controlled by inserting the linearly tapered pin **73** into it. The blunt end of pin **73** is fixed to rod **71**. Rod **71** is passed, (via supporting O-ring **75**), through opening **81** in housing **30**, to the manual adjustment mechanism **83**.

Spring **49** retains the rod **71** in a fixed position relative to pin **73** and opening **42**. When mechanism **83** is operated, pin **73** moves back from the opening **42**. As pin **73** is tapered, this backward movement increases the free area of opening **42**, thereby increasing the amount of gas passing from chamber **43** to chamber **47**.

The stops **67** and **69** maintain spring **49** in its stable position. The nuts **63** and **67** on threaded rod **61** are used to set the minimum open area of opening **42** by the correct positioning of pin **73**. This minimum opening setting, controls the idle speed of the engine, so pin **73** is locked in its correct position by nuts **63** and **67**. This adjustment controls the minimum rate of gas flow from chamber **43** to chamber **47** which will allow continuous operation of the combustion engine.

Referring now to **Fig.8** which illustrates the air adjustment control for manipulating the amount of air passing into the mixing chamber **20**. The closure **21** mounted on plate **18** has an opening **17** on end **11**. A plate-control **42** is mounted so as to slide over opening **17**. The position of this plate, relative to opening **17**, is controlled by the position of the control rod **19** which passes through grommet **12** to control line **13**. Release valve **24** is designed to rupture should any malfunction occur which causes the combustion of the gasses in mixing chamber **20**.

FIG. 4.

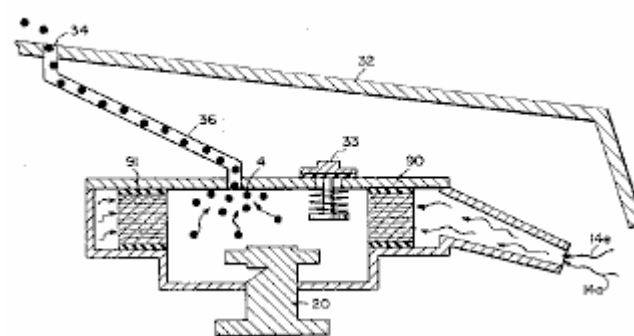

With reference now to **Fig.4**, if hydrogen gas **4** were to accumulate in mixing chamber **20** and reach an excessive pressure, the escape tube **36** which is connected to port **34** (located on the car bonnet **32**), permits the excess hydrogen gas to escape safely to the atmosphere. In the event of a malfunction which causes the combustion of the gasses in mixing chamber **20**, the pressure relief valve **33** will rupture, expelling the hydrogen gas without combustion.

In the constructed arrangement of **Fig.1**, there is illustrated a gas control system which may be fitted to an existing car's internal combustion engine without changing or modifying the car's design parameters or characteristics. The flow of the volatile hydrogen gas is, of course, critical; therefore, there is incorporated in line **5** a gas-flow valve **53**, and this is used to adjust the hydrogen flow. This gas-flow valve is shown in detail in **Fig.3**.

FIG. 8.

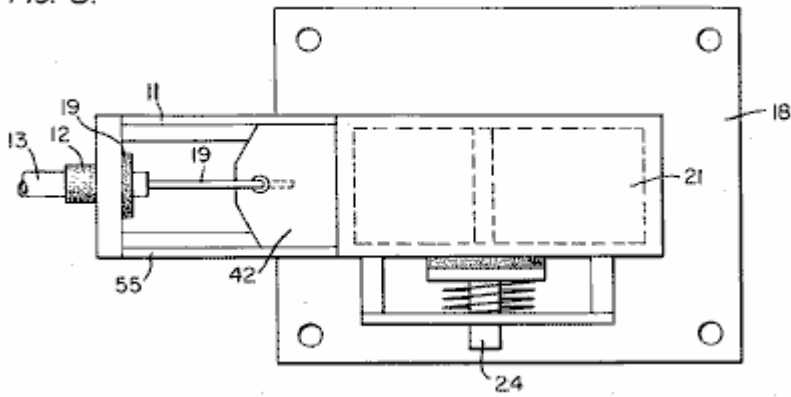

The intake air **14** may be in a carburettor arrangement with an intake adjustment **55** which adjusts the plate **42** opening. This is shown more fully in **Fig.8**. To maintain constant pressure in hydrogen gas storage **7** in the on-off operation of the engine, the gas flow control valve is responsive to the electrical shut-off control **33**. The constant pressure permits an abundant supply of gas on start-up and during certain periods of running time in re-supply.

The switch **33** is in turn responsive to the vacuum control switch **60**. During running of the engine vacuum will be built up which in turn leaves switch **33** open by contact with vacuum switch **60** through lead **60a**. When the engine is not running the vacuum will decrease to zero and through switch **60** will cause electrical switch **33** to shut off cutting off the flow of hydrogen gas to the control valve **53**.

As low-voltage direct current is applied to safety valve **28**, solenoid **29** is activated. The solenoid applies a control voltage to the hydrogen generator exciter **3** via terminal **27** through pressure switch **26**. As the electrical power activates solenoid **29**, hydrogen gas is caused to pass through flow adjustment valve **16** and then outlet pipe **5** for utilisation. The pressure differential hydrogen gas output to gas mixing chamber **20** is for example 30 lbs. to 15 lbs. Once hydrogen generator **10** reaches an optimum gas pressure level, pressure switch **26** shuts off the electrical power to the hydrogen exciters. If the chamber pressure exceeds a predetermined level, the safety release valve **28** is activated disconnecting the electrical current and thereby shutting down the entire system for safety inspection.

FIG. 6.

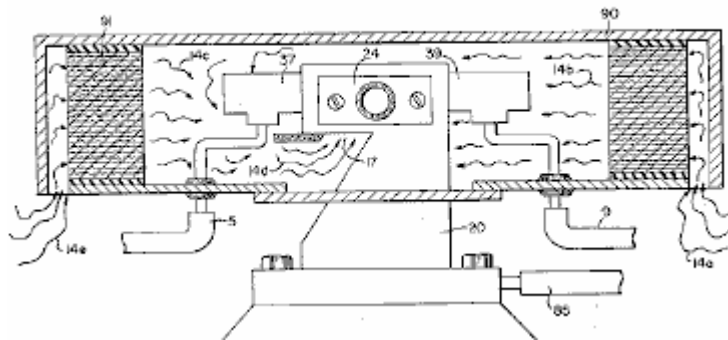

With particular reference now to **Fig.6** which illustrates the fuel injector system in a side cross-sectional view and to **Fig.5** the top view. The structural apparatus incorporated in the preferred embodiment comprises housing **90** which has air intakes **14a** and **14e**. The air passes through filter **91** around the components **14b** and **14c** and then to intake **14d** of the mixing chamber **20**. The hydrogen enters via line **5** via quenching plates **37** and into the mixing chamber **20**. The non-volatile gasses pass via line **9** to the quenching plates **39** and into the mixing chamber **20**.

FIG. 7

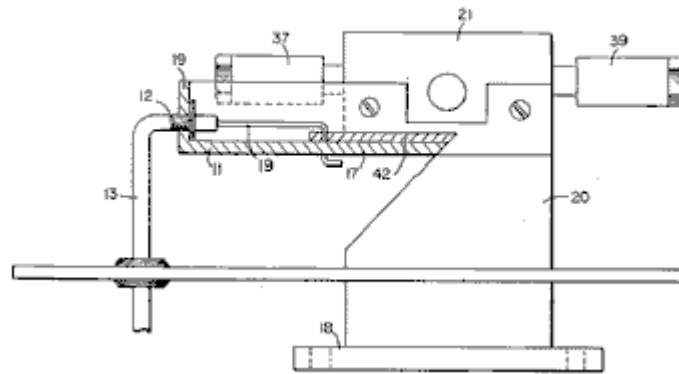
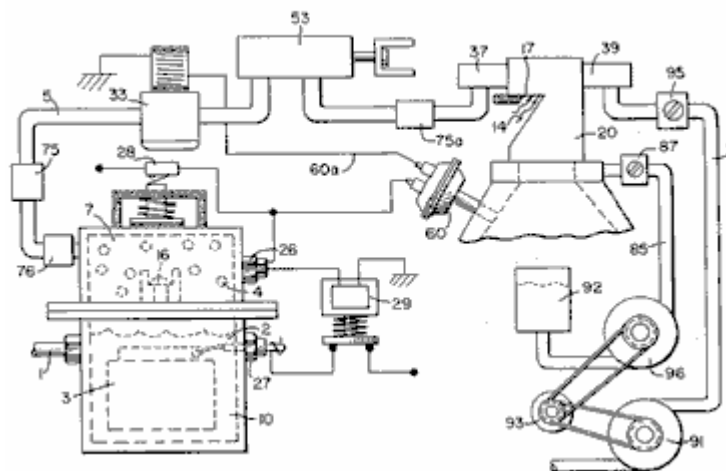

Fig.7 illustrates the mechanical arrangement of the components which make up the overall structure of mixing chamber 20 (shown independently in the other figures).

FIG. 1



Returning to Fig.1 there is illustrated the non-volatile gas line 9 passing through mixture pump 91 by engine pulley 93. Valve 95 controls the rate of flow. Also driven by pulley 93 is pump 96 having line 85 connected to an oil reservoir 92 and valve 87 and finally to mixing chamber 20. As a practical matter, such as in a non-oil lubricated engine, lubricating fluid such as oil 81 is sprayed in the chamber 20, via oil supply line 85 for lubrication.

There have been several publications in the past year or so, delving into the properties of Hydrogen gas, its potential use, generating systems, and safety. One such publication is "Selected Properties of Hydrogen" (Engineering Design Data) issued February 1981 by the National Bureau of Standards.

These publications are primarily concerned with the elaborate and costly processes for generating hydrogen. Equally so, they are concerned with the very limited use of hydrogen gas because of its extremely high burning velocities. This in turn reflects the danger in the practical use of hydrogen.

With reference to the graph of the Appendix A, it is seen that the burning velocities of alcohol, propane, methane, petrol, Liquid Petroleum Gas, and diesel oil are in the range of minimum 35 to maximum 45. Further, the graph illustrates that the burning velocity of hydrogen gas is in the range of 265 minimum to 325 maximum. In simple terms, the burning velocity of hydrogen is of the order of 7.5 times the burning velocity of ordinary commercial fuels.

Because of the unusually high burning velocity of hydrogen gas, it has been ruled out as a substitute fuel, by these prior investigators. Further, even if an engine could be designed to accommodate such high burning velocities, the danger of explosion would eliminate any thoughts of commercial use.

The present invention, as above described, has resolved the above-noted criteria for the use of hydrogen gas in a standard commercial engine. Primarily, the cost in the generation of hydrogen gas, as noted in the aforementioned co-pending patent applications, is minimal. Water with no chemicals or metals is used. Also, as noted in the aforementioned co-pending patent applications, the reduction in the hydrogen gas burn velocity has

been achieved. These co-pending applications not only teach the reduction in velocity, but teach the control of the velocity of the hydrogen gas.

In the preferred embodiment, practical apparatus adapting the hydrogen generator to a combustion engine is described. The apparatus linearly controls the hydrogen gas flow to a mixing chamber mixing with a controlled amount of non-combustible gas oxygen, hence, the reduction in the hydrogen gas velocity. The reduction in the hydrogen gas velocity makes the use of hydrogen as safe as other fuels.

In more practical terms the ordinary internal combustion engine of any size or type of fuel, is retrofitted to be operable with only water as a fuel source. Hydrogen gas is generated from the water without the use of chemicals or metals and at a very low voltage. The burning velocity of the hydrogen gas has been reduced to that of conventional fuels. Finally, every component or step in the process has one or more safety valves or features thereby making the hydrogen gas system safer than that of conventional cars.

In the above description the terms 'non-volatile' and 'non-combustible' were used. It is to be understood they are intended to be the same; that is, simply, gas which will not burn.

Again, the term 'storage' has been used, primarily with respect to the hydrogen storage area 7. It is not intended that the term 'storage' be taken literally - in fact, it is not storage, but a temporary holding area. With respect to area 7, this area retains a sufficient amount of hydrogen for immediate start-up.

Other terms, features, apparatus, and the such have been described with reference to a preferred embodiment. It is to be understood modifications and alternatives can be had without departing from the spirit and scope of the invention.

HYDROGEN GAS BURNER

Please note that this is a re-worded excerpt from this patent. It describes how to burn the hydrogen and oxygen gas mix produced by electrolysis of water. Normally, the flame produced is too hot for practical use other than cutting metal or welding. This patent shows a method of reducing the flame temperature to levels suitable for general use in boilers, stoves, heaters, etc.

ABSTRACT

A hydrogen gas burner for the mixture of hydrogen gas with ambient air and non-combustible gasses. The mixture of gasses when ignited provides a flame of extremely high, but controlled intensity and temperature.

The structure comprises a housing and a hydrogen gas inlet directed to a combustion chamber positioned within the housing. Air intake ports are provided for adding ambient air to the combustion chamber for ignition of the hydrogen gas by an ignitor therein. At the other end of the housing there is positioned adjacent to the outlet of the burner (flame) a barrier/heating element. The heating element uniformly disperses the flame and in turn absorbs the heat. The opposite side to the flame, the heating element uniformly disperses the extremely hot air. A non-combustible gas trap adjacent to the heating element captures a small portion of the non-combustible gas (burned air). A return line from the trap returns the captured non-combustible gas in a controlled ratio to the burning chamber for mixture with the hydrogen gas and the ambient air.

CROSS REFERENCE

The hydrogen/oxygen generator utilised in the present invention is that disclosed and claimed in my co-pending patent application, Serial. No.: 302,807, filed: Sept. 16, 1981, for: HYDROGEN GENERATOR SYSTEM. In that process for separating hydrogen and oxygen atoms from water having impurities, the water is passed between two plates of similar non-oxidising metal. No electrolyte is added to the water. The one plate has placed thereon a positive potential and the other a negative potential from a very low amperage direct-current power source. The sub-atomic action of the direct current voltage on the non-electrolytic water causes the hydrogen and oxygen atoms to be separated--and similarly other gasses entrapped in the water such as nitrogen. The contaminants in the water that are not released are forced to disassociate themselves and may be collected or utilised and disposed of in a known manner.

The direct current acts as a static force on the water molecules; whereas the non-regulated rippling direct current acts as a dynamic force. Pulsating the direct current further enhances the release of the hydrogen and oxygen atoms from the water molecules.

In my co-pending patent application, Serial. No. 262,744, filed: May 11, 1981, for: HYDROGEN AERATION PROCESSOR, there is disclosed and claimed the utilisation of the hydrogen/oxygen gas generator. In that system, the burn rate of the hydrogen gas is controlled by the controlled addition of non-combustible gasses to the mixture of hydrogen and oxygen gasses.

SUMMARY OF INVENTION

The present invention is for a hydrogen gas burner and comprises a combustion chamber for the mixture of hydrogen gas, ambient air, and non-combustible gasses. The mixture of gasses is ignited and burns at a retarded velocity rate and temperature from that of hydrogen gas, but at a higher temperature rate than other gasses.

The extremely narrow hydrogen gas mixture flame of very high temperature is restricted from the utilisation means by a heat absorbing barrier. The flame strikes the barrier which in turn disperses the flame and absorbs the heat therefrom and thereafter radiates the heat as extremely hot air into the utilisation means.

Positioned on the opposite side of the heat radiator/barrier is a hot air trap. A small portion of the radiated heat is captured and returned to the combustion chamber as non-combustible gasses. Valve means in the return line regulates the return of the non-combustible gas in a controlled amount to control the mixture.

The present invention is principally intended for use with the hydrogen generator of my co-pending patent application, supra; but it is not to be so limited and may be utilised with any other source of hydrogen gas.

OBJECTS

It is accordingly a principal object of the present application to provide a hydrogen gas burner that has a temperature controlled flame and a heat radiator/barrier.

Another object of the present invention is to provide a hydrogen gas burner that is capable of utilising the heat from a confined high temperature flame.

Another object of the present invention is to provide a hydrogen gas burner that is retarded from that of hydrogen gas, but above that of other gasses.

Another object of the present invention is to provide a hydrogen gas burner that utilises the exhaust air as non-combustible gas for mixture with the hydrogen gas.

Another object of the present invention is to provide a hydrogen gas burner that is simple but rugged and most importantly safe for all intended purposes.

Other objects and features of the present invention will become apparent from the following detailed description when taken in conjunction with the drawings in which:

BRIEF DESCRIPTION OF THE DRAWINGS

Fig.1 is an overall cross-sectional view of the present invention in its most preferred embodiment.

Fig. 1

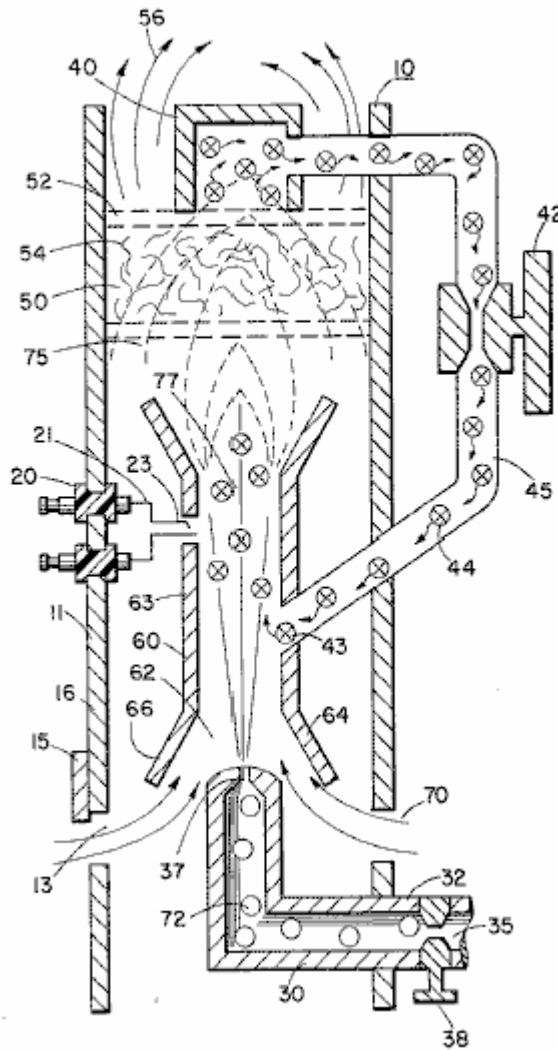
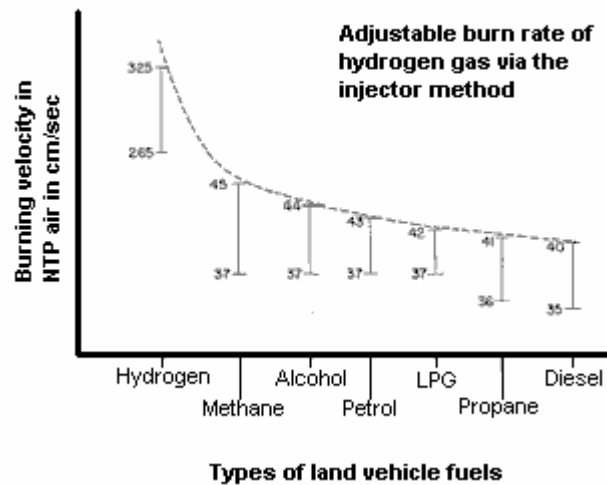

Fig.2 is a graphical illustration of the burning of various standard fuels with that of hydrogen velocities.

Fig. 2



DETAILED DESCRIPTION OF INVENTION

Fig. 1

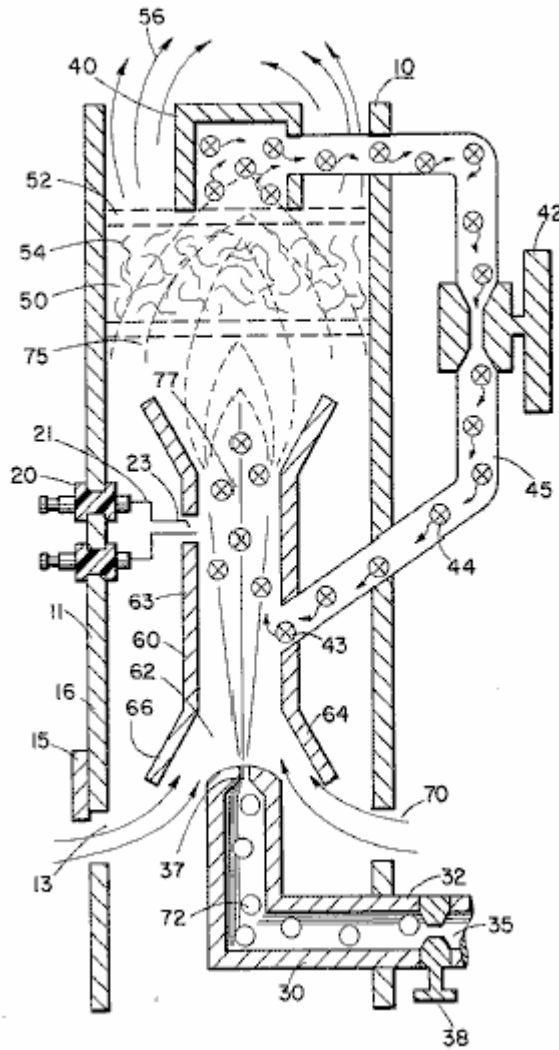

With particular reference **Fig.1** there is illustrated in a schematic cross-section the principals of the present invention. The structure of the preferred embodiment comprises a housing **10**, having an igniter **20** extending through the wall **11** thereof. A combustion chamber **60** positioned within the housing **10** has a first open end **62**. A hydrogen gas **72** inlet **30** directs hydrogen gas via port **37** from a source **35** to the inlet **62** of the combustion chamber **68**. Also directed to the same inlet **62**, and assisted by flanges **64** and **66**, is ambient air **70** entering through ports **13** in the housing **10**.

Adjacent the opposite end of the combustion chamber **60** the gas mixture **75** is ignited by the igniter **20** to produce flame **77**. The velocity of the flame **77** causes it to strike and penetrate the barrier/radiator **50**. The barrier **50** is of a material, such as metallic mesh or ceramic material, to disperse therein the flame and in turn become saturated with heat. The flame **77** is of a size sufficient to be dispersed throughout the barrier **50**, but yet, not penetrate through the barrier **50**.

Radiated from the surface **52** of the barrier **50** is superheated air **56** (gasses) to be passed on to a utilisation device. Adjacent to surface **52** of barrier/radiator **50** is a hot air trap **40** with closed loop line **45** returning non-combustible gas **44** to the combustion chamber **60**. Control valve **42** is intermediate the line **45**.

In operation of the preferred embodiment hydrogen gas, **72**, emitted from the nozzle **37** is directed to the combustion chamber **60**. The flanges **64** and **66** on the open end of housing **63** of the combustion chamber **60** enlarges the open end of **62**. In the enlargement ambient air from the opening **13** in the housing **10** is also directed to the combustion chamber **60**.

The ambient air and hydrogen traverses the opening **43** and further mixes with the non-combustible gas **44** from the closed loop line **45** with the hot air trap **40**. The mixture of hydrogen gas **72**, ambient air **70**, and non-combustible gas **44**, is ignited by the igniter **20** having electrical electrodes **21** and **23**. Upon ignition flame **77** ensues. The mixture is controlled with each of three gasses. That is, the line **32** from the hydrogen source **35** has a valve **38** therein for controlling the amount of hydrogen **72** emitted from the nozzle **37**. The opening **13** has a

plate adjustment **15** for controlling the amount of ambient air **60** directed to the combustion chamber **60**, and the closed-loop line has valve **42**, as aforesaid, for controlling the amount of non-combustible gasses in the mixture.

It can be appreciated that the temperature of the flame **77** and the velocity of the flame **77** is a function of the percentage of the various gasses in the mixture. In a practical embodiment, the flame **70** temperature and velocity was substantially retarded from that of a hydrogen flame per se; but yet, much greater than the temperature and velocity of the flame from the gasses utilised in a conventional heating system.

To maintain a sufficient pressure for combustion of the hydrogen gas mixture with a minimum of pressure (for safety) and to limit blow-out, the nozzle **37** opening **39** is extremely small. As a consequence, if the hydrogen gas were burned directly from the nozzle **37**, the flame would be finite in diameter. Further, its velocity would be so great it is questionable whether a flame could be sustained. The mixing of ambient air and non-combustible gas does enlarge the flame size and reduce its velocity. However, to maintain a flame higher in temperature and velocity than the conventional gasses, the size and temperature of the flame is controlled by the mixture mentioned earlier.

Therefore, to utilise the flame **77** in a present day utilisation means, the flame is barred by the barrier **50**. The barrier **50** is of a material that can absorb safely the intense flame **77** and thereafter radiate heat from its entire surface **52**. The material **54** can be a ceramic, metallic mesh or other heat absorbing material known in the art. The radiated heat **56** is directed to the utilisation means.

As stated earlier, the mixture of gasses which are burned include non-combustible gasses. As indicated in the above-noted co-pending patent applications, an excellent source of non-combustible gasses is exhaust gasses. In this embodiment, the trap **50** entraps the hot air **74** and returns the same, through valve **42**, to the combustion chamber **60** as non-combustible gas.

With reference to **Fig.2** there is illustrated the burning velocity of various standard fuels. It can be seen the common type of fuel burns at a velocity substantially less than hydrogen gas. The ratio of hydrogen with non-combustible oxygen gasses is varied to obtain optimum burning velocity and temperature for the particular utilisation. Once this is attained, the ratio, under normal conditions, will not be altered. Other uses having different fuel burn temperature and velocity will be adjusted in ratio of hydrogen/oxygen to non-combustible gasses in the same manner as exemplified above.

Further, perhaps due to the hydrogen gas velocity, there will occur unburned gas at the flame **77** output. The barrier **50**, because of its material makeup will retard the movement and trap the unburned hydrogen gas. As the superheated air **77** is dispersed within the material **54**, the unburned hydrogen gas is ignited and burns therein. In this way the barrier **50** performs somewhat in the nature of an after-burner.

STANLEY MEYER

US Patent 5,149,407

22nd September 1992

Inventor: Stanley Meyer

PROCESS AND APPARATUS FOR THE PRODUCTION OF FUEL GAS AND THE ENHANCED RELEASE OF THERMAL ENERGY FROM SUCH GAS

Please note that this is a re-worded excerpt from this patent. It describes in considerable detail, one of Stan's methods for splitting water into hydrogen and oxygen gasses and the subsequent methods for using those gasses.

ABSTRACT

Water molecules are broken down into hydrogen and oxygen gas atoms in a capacitive cell by a polarisation and resonance process dependent on the dielectric properties of water and water molecules. The gas atoms are then ionised or otherwise energised and thermally combusted to release a degree of energy greater than that of combustion of the gas in air.

OBJECTS OF THE INVENTION

A first object of the invention is to provide a fuel cell and a process in which molecules of water are broken down into hydrogen and oxygen gasses, and a fuel gas mixture comprised of hydrogen, oxygen and other gasses formerly dissolved in the water, is produced. A further object of the invention is to realise significant energy-yield from a fuel gas derived from water molecules. Molecules of water are broken down into hydrogen and oxygen gasses. Electrically charged hydrogen and oxygen ions of opposite electrical polarity are activated by electromagnetic wave energy and exposed to a high temperature thermal zone. Significant amounts of thermal energy with explosive force beyond the gas burning stage are released.

An explosive thermal energy under a controlled state is produced. The process and apparatus provide a heat energy source useful for power generation, aircraft rocket engines or space stations.

BRIEF DESCRIPTION OF THE DRAWINGS

Figs.1A through **1F** are illustrations depicting the theoretical bases for phenomena encountered during operation of the fuel gas production stage of the invention.

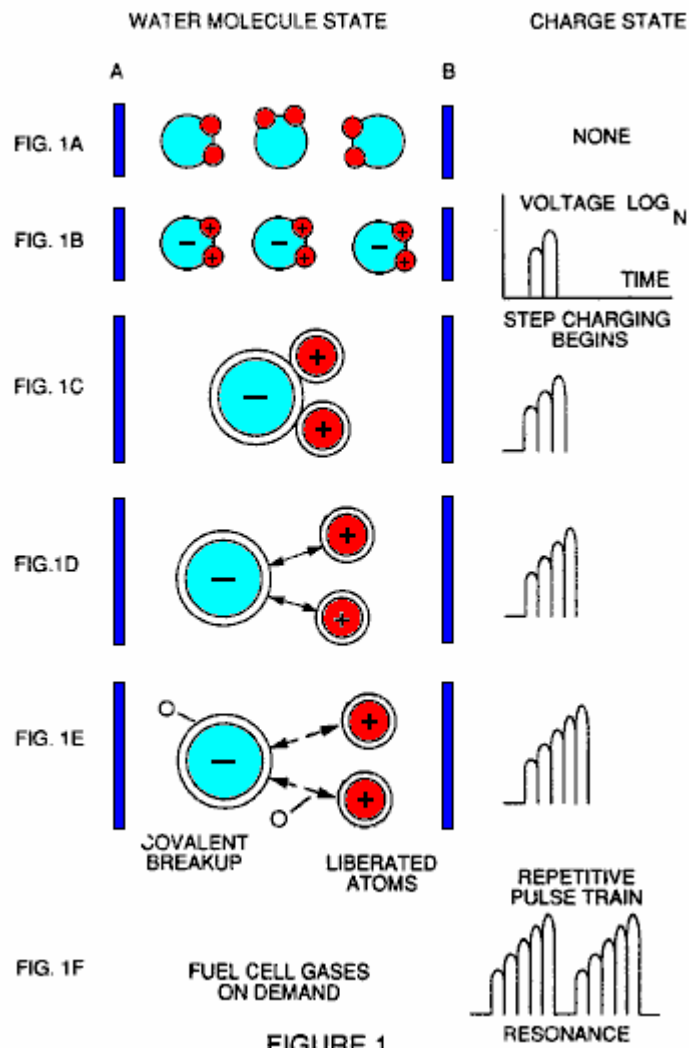

FIGURE 1

Fig.2 illustrates a circuit which is useful in the fuel gas generation process.

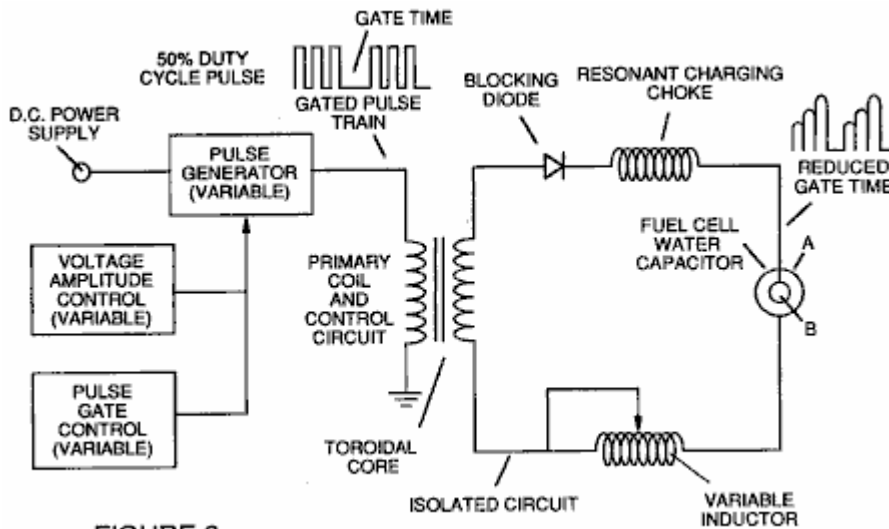

FIGURE 2

Fig.3 shows a perspective of a “water capacitor” element used in the fuel cell circuit.

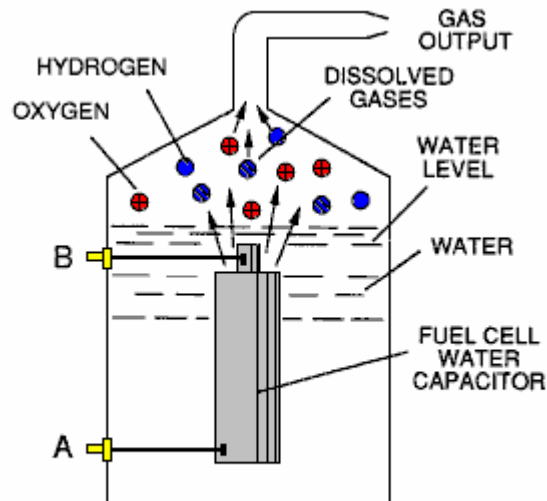

FIGURE 3

Fig.4 illustrates a staged arrangement of apparatus useful in the process, beginning with a water inlet and culminating in the production of thermal explosive energy.

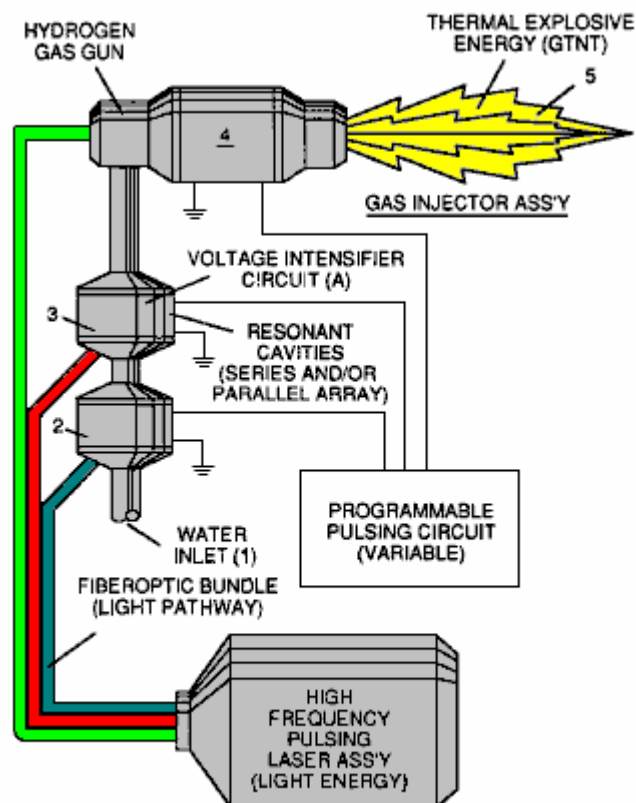

FIGURE 4

Fig.5A shows a cross-section of a circular gas resonant cavity used in the final stage assembly of Fig.4

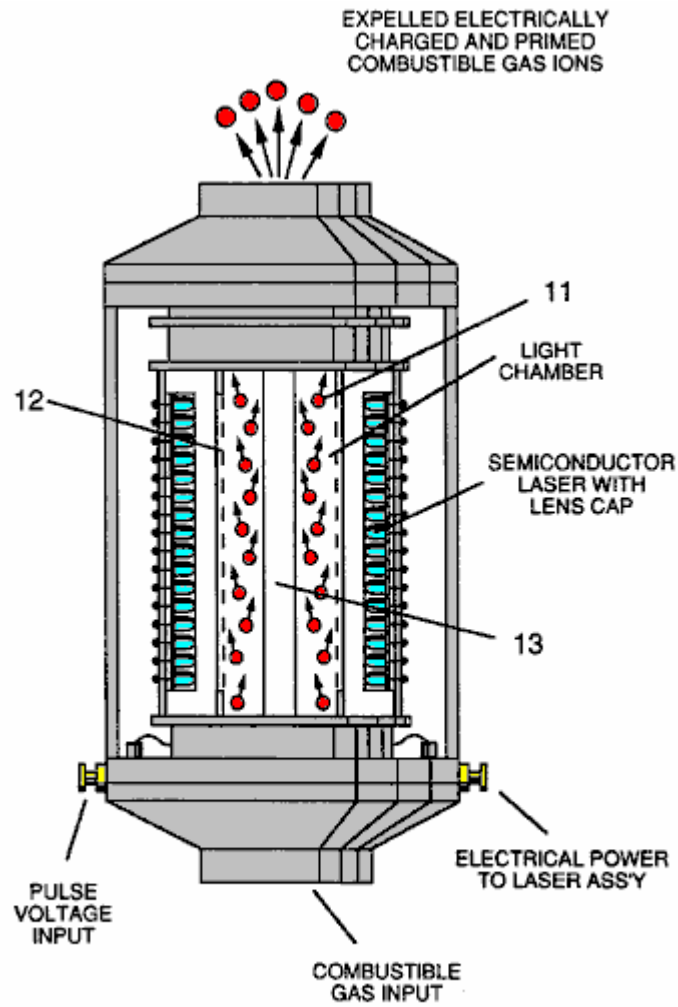

FIGURE 5A

Fig.5B shows an alternative final stage injection system useful in the apparatus of Fig.4

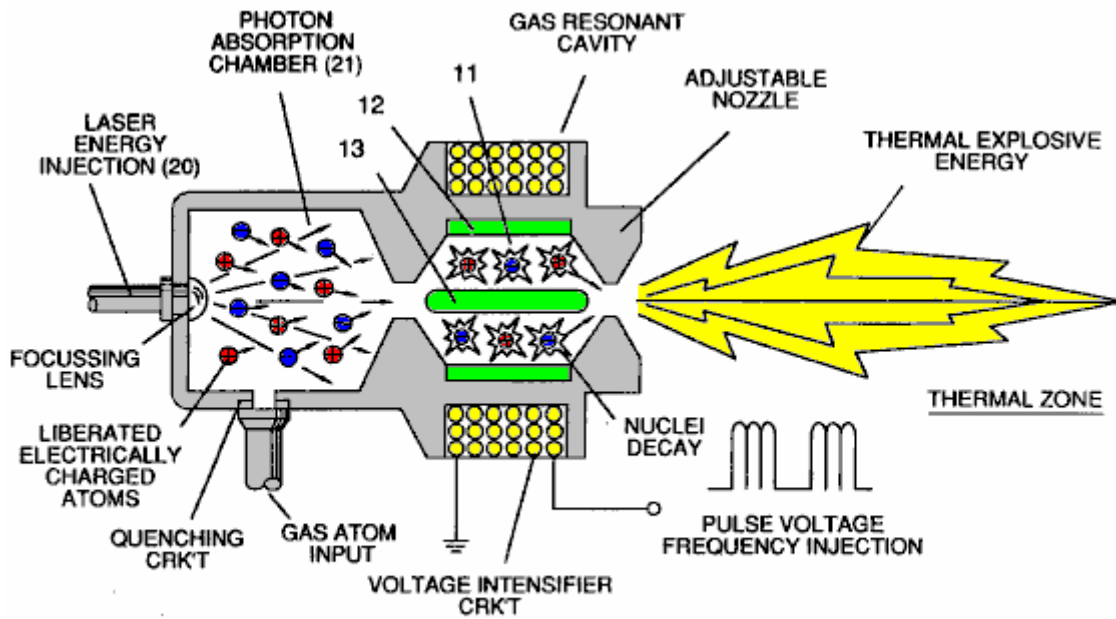

FIGURE 5B

Fig.5C shows an optical thermal lens assembly for use with either final stage of Fig.5A or Fig.5B.

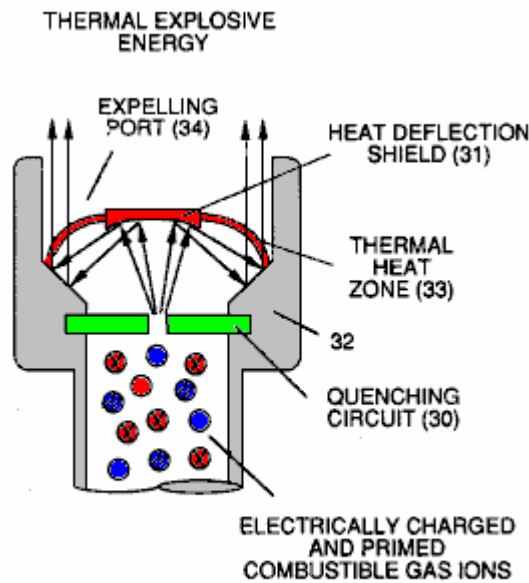

FIGURE 5C

Figs.6A, 6B, 6C and 6D are illustrations depicting various theoretical bases for atomic phenomena expected to occur during operation of this invention.

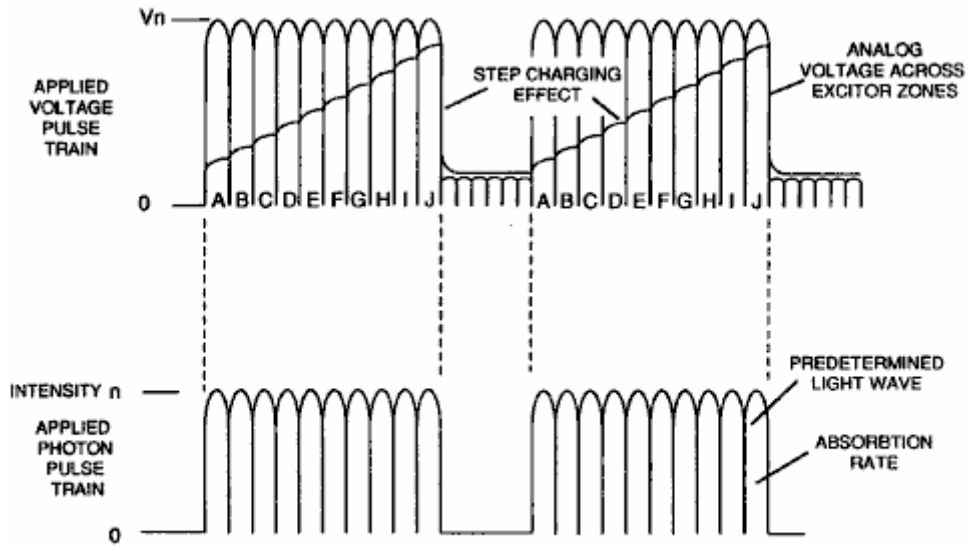

FIGURE 6A

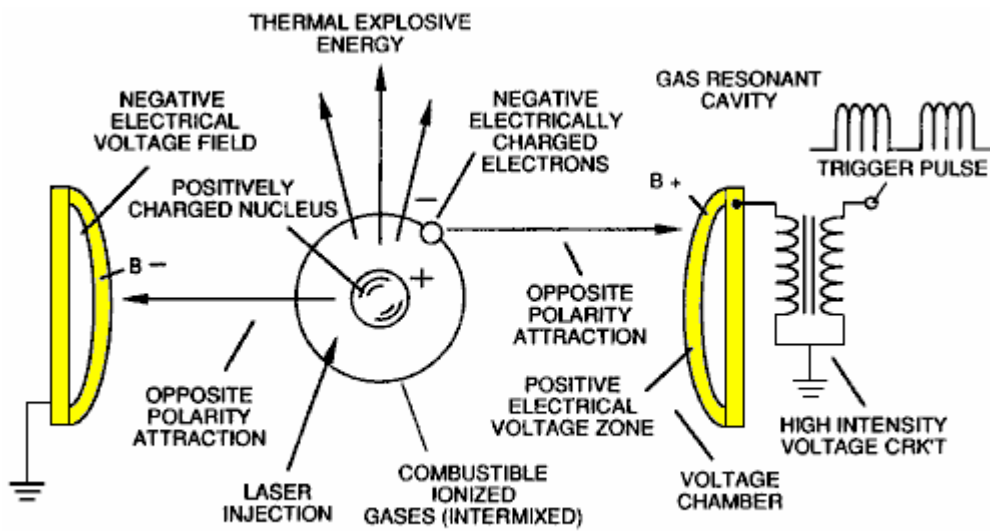

FIGURE 6B

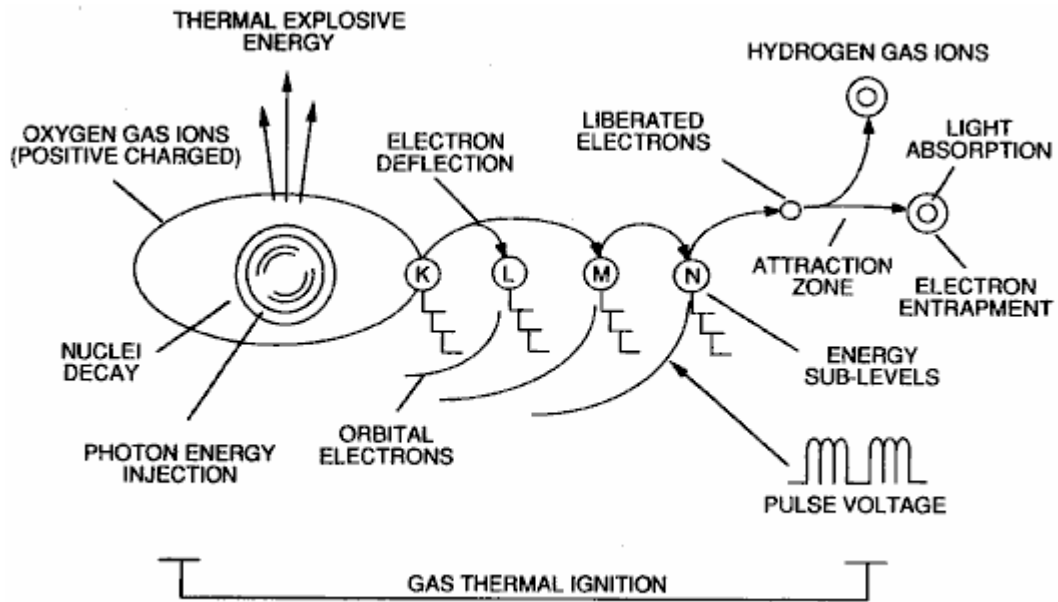

FIGURE 6C

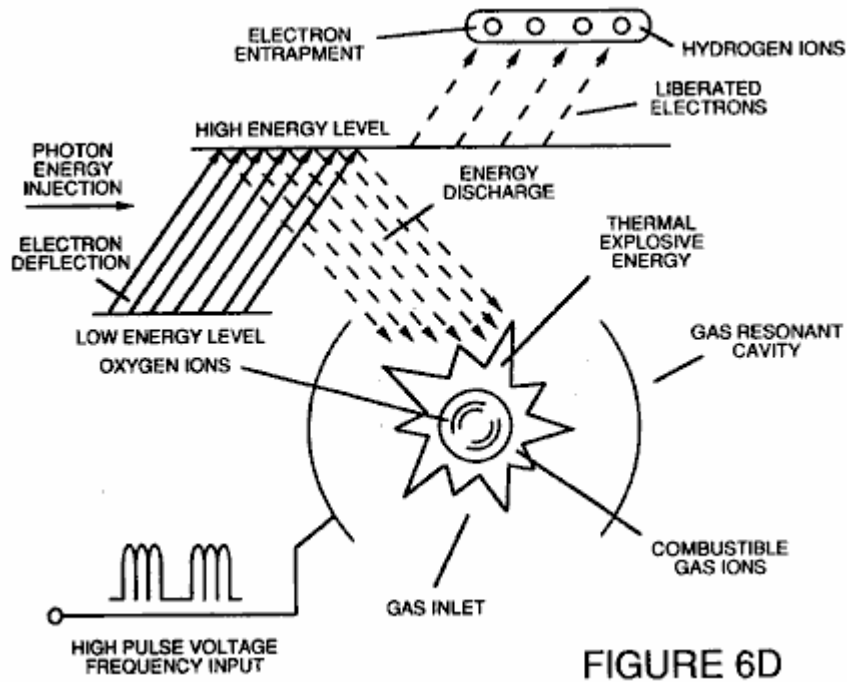

FIGURE 6D

Fig.7 is an electrical schematic of the voltage source for the gas resonant cavity.

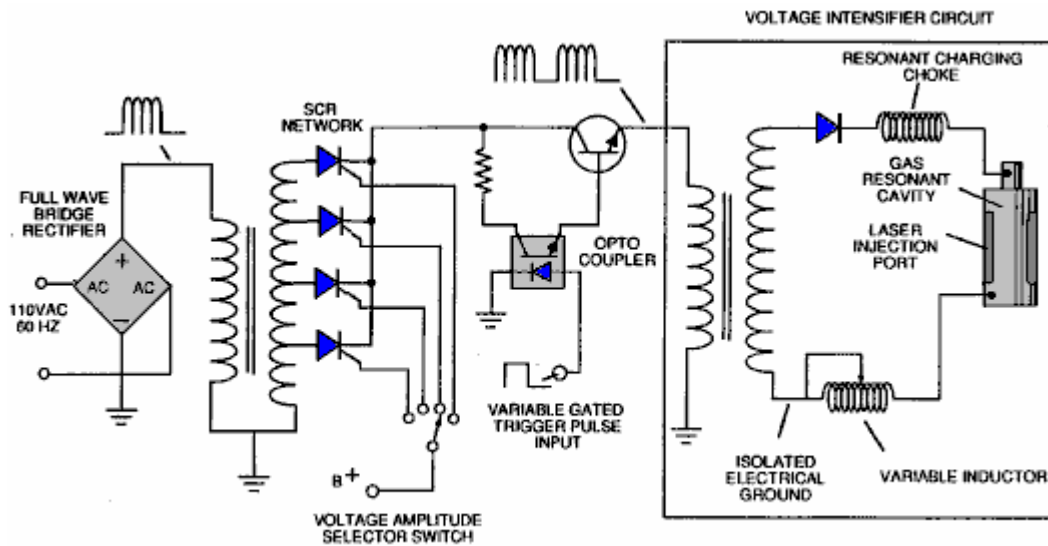

FIGURE 7

Figs.8A and 8B respectively, show (A) an electron extractor grid used in the injector assemblies of Fig.5A and Fig.5B, and (B) the electronic control circuit for the extractor grid.

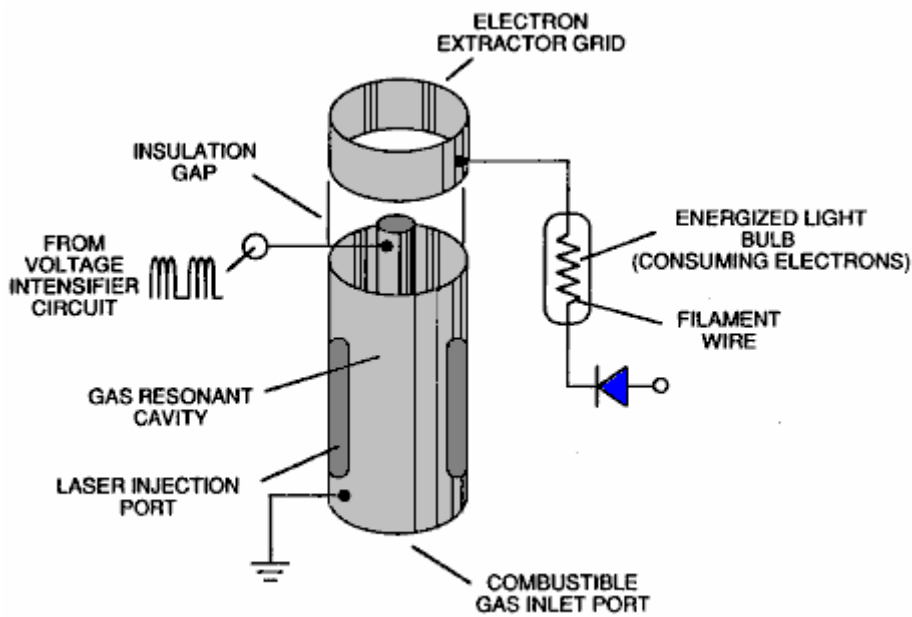

FIGURE 8A

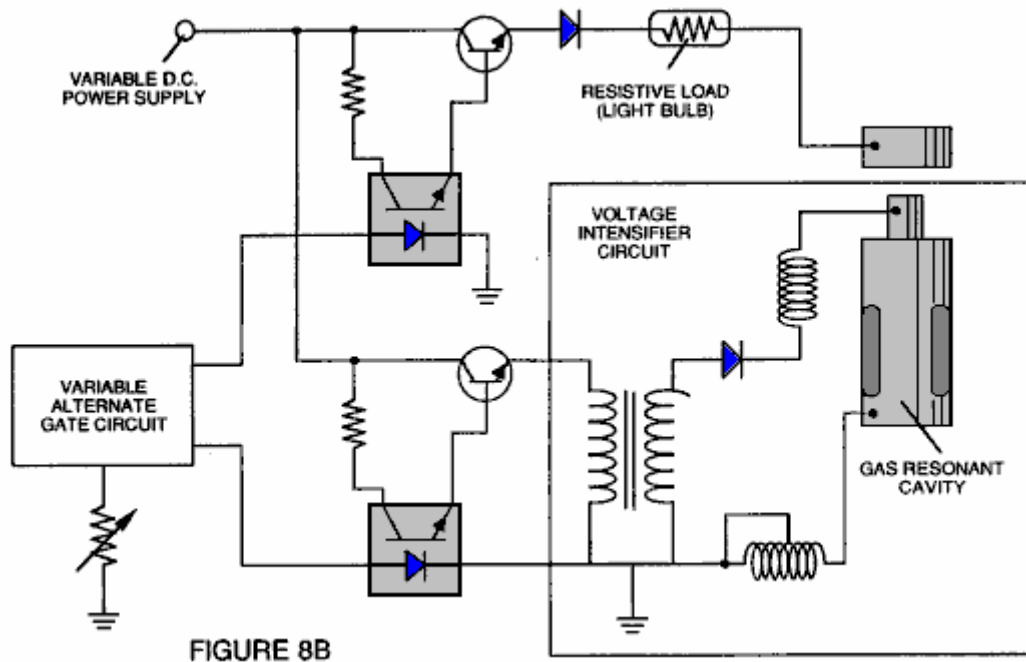

FIGURE 8B

Fig.9 shows an alternative electrical circuit useful in providing a pulsating waveform to the apparatus.

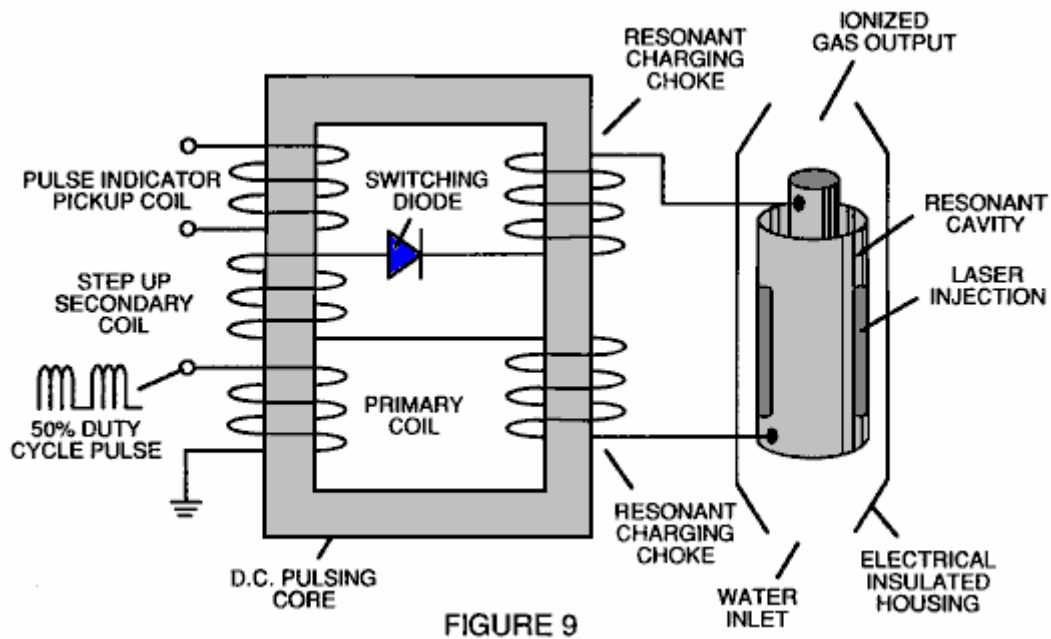

FIGURE 9

TABLE 1: PROCESS STEPS LEADING TO IGNITION

Relative State of Water Molecule and/or Hydrogen/Oxygen/Other Atoms	Stage
Random (ambient state) alignment of polar fields, polarisation of molecules. Molecular elongation. Atom liberation by breakdown of covalent bond	1st Stage: Water to Gas
Release of gasses, Liquid to gas ionisation, Electrical charging effect, Particle Impact	2nd Stage: Gas Ionisation
Electromagnetic Wave, Laser or photon injection, Electron extraction, Atomic destabilisation	3rd Stage: Priming
Thermal Ignition	Final Stage: Ignition

DESCRIPTION OF THE PREFERRED EMBODIMENT

A fuel gas is produced by a hydrogen fracturing process which follows the sequence of steps shown in Table 1. Beginning with water molecules, the molecule is subjected to successively increasing electrical wave energy and thermal forces. In the succession of forces, randomly orientated water molecules are aligned with respect to molecular polar orientation and themselves polarised and “elongated” by the application of an electric potential, to the extent that the co-valent bonding of the water molecules is so weakened that the atoms disassociate and the molecule breaks down into hydrogen and oxygen elemental components. Next, the released atomic gasses are ionised and electrically charged in a vessel while being subjected to a further energy source which promotes inter-particle impact in the gas at an increased overall energy level. Finally, the atomic particles in the excited gas, having achieved successively higher energy levels, are subjected to a laser or electromagnetic wave energy source which produces atomic destabilisation and the final release of thermal explosive energy.

Engineering design parameters based on known theoretical principles of atomic physics, determine the incremental levels of electrical and wave energy input required to produce resonance in each stage of the system. Instead of a dampening effect, a resonant energisation of the molecule, atom or ion provides a compounding energy interaction resulting in the final energy release.

In brief, in the first stage, a gas mixture including hydrogen, oxygen and other gasses formerly dissolved in the water, is obtained from water. In general, the method used in the first stage consists of:

- (A) Providing a capacitor, in which the water is included as a dielectric liquid between capacitor plates, in a resonant charging choke circuit, which includes an inductor in series with the capacitor.
- (B) Subjecting the capacitor to a pulsating, unipolar electric voltage field in which the polarity does not pass beyond an arbitrary ground, whereby the water molecules within the capacitor are subjected to a charge of the same polarity, and the water molecules are distended by the electrical polar forces.
- (C) Further subjecting the water in the capacitor to the pulsating electric field to achieve a pulse frequency which induces a resonance within the water molecule.
- (D) Continuing the application of the pulsing frequency to the capacitor cell after resonance occurs so that the energy level within the molecule is increased in cascading incremental steps in proportion to the number of pulses.
- (E) Maintaining the charge of the capacitor during the application of the pulsating field, whereby the co-valent electrical bonding of the hydrogen and oxygen atoms within the water molecules is destabilised to such a degree that the force of the electrical field within the molecule exceeds the bonding force of the molecule, causing the molecule to break apart into the elemental gasses of hydrogen and oxygen.
- (F) Collecting the hydrogen and oxygen gasses, along with any other gasses formerly dissolved in the water, and discharging the collected gasses as a fuel gas mixture.

The water molecules are subjected to increasing electrical forces. In an ambient state, randomly orientated water molecules are aligned with respect to a molecular polar orientation. Next, they themselves are polarised and “elongated” by the application of an electrical potential to the extent that co-valent bonding of the water molecules is so weakened that the atoms disassociate and the molecule breaks down into hydrogen and oxygen elemental components. In this process, the point of optimum gas release is reached when the circuit is at resonant frequency. Water in the cell is subjected to a pulsating, polar electric field produced by the electrical circuit, whereby the water molecules are distended by the electrical force on the plates of the capacitor. The polar pulsating frequency applied is such that the pulsating electric field induces a resonance in the molecules. A cascade effect occurs, and the overall energy of specific water molecules is increased in cascading incremental steps. The hydrogen and oxygen are released when the resonant energy exceeds the co-valent bonding force of the water molecules.

A preferred construction material for the capacitor plates is stainless steel T-304 which does not react chemically with water, hydrogen or oxygen. An electrically conductive material which is inert in the fluid environment, is a desirable material of construction for the electric field plates of the “water capacitor” employed in the circuit.

Once triggered, the gas output is controllable by the attenuation of operational parameters. Thus, once the frequency of resonance is identified, by varying the applied pulse voltage to the water fuel cell assembly, gas output is varied. By varying the pulse shape, pulse amplitude or pulse train sequence, the gas output can be varied. Attenuation of the voltage field’s mark/space ratio of OFF/ON periods also affects the rate of gas production.

The overall apparatus thus includes an electrical circuit in which a water capacitor is an element. The water capacitor has a known dielectric property. The fuel gasses are obtained from the water by the disassociation of the water molecules. The water molecules are split into component atomic elements by a voltage stimulation process called the ‘electrical Polarisation process’ which also releases dissolved gasses trapped in the water.

From the outline of physical phenomena associated with the first stage of the process described in Table 1, the theoretical basis of the invention considers the respective states of molecules, gasses and ions derived from liquid water. Before voltage stimulation, water molecules are randomly dispersed throughout water in a container.

When a unipolar voltage pulse train such as that shown in **Figs.1B** through **1F** is applied to positive and negative capacitor plates, and increasing voltage potential is induced in the molecules in a linear, step-like charging effect. The electrical field of the particles within a volume of water including the electrical field plates, increases from a low energy state to a high energy state in a step manner following each pulse train as illustrated figuratively in **Figs.1A** through **1F**. The increasing voltage potential is always positive in direct relationship to negative ground potential during each pulse. The voltage polarity on the plates which create the voltage fields remains constant although the voltage charge increases. Positive and negative voltage “zones” are thus formed simultaneously in the electrical field of the capacitor plates.

In the first stage of the process described in Table 1, because the water molecule naturally exhibits opposite electrical fields in a relatively polar configuration (the two hydrogen atoms have a positive charge while the oxygen atom has a negative charge), the voltage pulse causes the water molecules which were initially orientated in random directions, to spin and align themselves with the electrical field applied to the cell. The positively charged hydrogen atoms are attracted to the negative field while the negatively charged oxygen atoms, of the same water molecule, are attracted to the positive voltage field. Even a slight potential difference between the plates of a containment chamber capacitor will initiate the alignment of each water molecule within the cell.

When the voltage applied to the plates causes the water molecules to align themselves, then the pulsing causes the voltage field intensity to be increased in accordance with **Fig.1B**. As further molecular alignment occurs, molecular movement is hindered. Because the positively charged hydrogen atoms of the aligned molecules are attracted in a direction opposite to the negatively charged oxygen atoms, a polar charge alignment or distribution occurs within the molecules between the voltage zones as shown in **Fig.1B**, and as the energy level of the atoms, subjected to resonant pulsing, increases, the stationary water molecules become elongated as shown in **Figs.1C** and **1D**. Electrically charged nuclei and electrons are attracted towards opposite electrically charged voltage zones - disrupting the mass and charge equilibrium of the water molecule.

As the water molecule is further exposed to an increasing potential difference resulting from the step charging of the capacitor, the electrical force of attraction of the atoms within the molecule to the capacitor plates of the chamber also increases in strength. As a result, the co-valent bonding between the atoms of the molecule is weakened and ultimately, terminated. The negatively charged electron is attracted toward the positively charged hydrogen atoms, while at the same time, the negatively charged oxygen atoms repel electrons.

In a more specific explanation of the “sub-atomic action which occurs in the water cell, it is known that natural water is a liquid which has a dielectric constant of 78.54 at 20 degrees Centigrade and 1 atmosphere of pressure [Handbook of Chemistry and Physics, Section E-50].

When a volume of water is isolated and electrically conductive plates that are chemically inert in water and which are separated by a distance, are immersed in the water, a capacitor is formed, having a capacitance determined by the surface area of the plates, the distance of their separation and the dielectric constant of the water.

When water molecules are exposed to voltage at a restricted current, water takes on an electrical charge. By the laws of electrical attraction, molecules align according to positive and negative polarity fields of the molecule and the alignment field. The plates of a capacitor constitute such an alignment field when a voltage is applied across them.

When a charge is applied to a capacitor, the electrical charge of the capacitor equals the applied voltage charge. In a water capacitor, the dielectric property of water resists the flow of current in the circuit, and the water molecule itself, because it has polarity fields formed by the relationship of hydrogen and oxygen in the co-valent bond, and an intrinsic dielectric property, becomes part of the electrical circuit, analogous to a “microcapacitor” within the capacitor defined by the plates.

In the Example of a fuel cell circuit of **Fig.2**, a water capacitor is included. The step-up coil is formed on a conventional toroidal core formed of a compressed ferromagnetic powered material that will not itself become permanently magnetised, such as the trademarked “Ferramic 06# ‘Permag’” powder as described in *Siemens Ferrites Catalogue*, CG-2000-002-121, (Cleveland, Ohio) No. F626-1205. The core is 1.50 inch in diameter and 0.25 inch in thickness. A primary coil of 200 turns of 24 AWG gauge copper wire is provided and a coil of 600 turns of 36 AWG gauge wire comprises the secondary winding. Other primary/secondary coil winding ratios may be conveniently determined.

An alternate coil arrangement using a conventional M27 iron transformer core is shown in **Fig.9**. The coil wrap is always in one direction only.

In the circuit of **Fig.2**, the diode is a 1N1198 diode which acts as a blocking diode and an electric switch which allows current flow in one direction only. Thus, the capacitor is never subjected to a pulse of reverse polarity.

The primary coil of the torroid is subject to a 50% duty-cycle pulse. The torroidal pulsing coil provides a voltage step-up from the pulse generator in excess of five times, although the relative amount of step-up is determined by pre-selected criteria for a particular application. As the stepped-up pulse enters the first inductor (formed of 100 turns of 24 gauge wire, 1 inch in diameter), an electromagnetic field is formed around the inductor. Voltage is switched off when the pulse ends, and the field collapses and produces another pulse of the same polarity; i.e. another positive pulse is formed where the 50% duty-cycle was terminated. Thus, a double pulse frequency is produced; however, in a pulse train of unipolar pulses, there is a brief time when pulses are not present.

By being so subjected to electrical pulses in the circuit of **Fig.2**, the water between the capacitor plates takes on an electrical charge which is increased by a step-charging phenomenon occurring in the water capacitor.. Voltage continually increases (to about 1000 volts and more) and the water molecules start to elongate.

The pulse train is then switched off; the voltage across the water capacitor drops to the amount of charge that the water molecules have taken on, i.e. voltage is maintained across the charged capacitor. The pulse train is then applied again.

Because a voltage potential applied to a capacitor can perform work, the higher the voltage potential, the more work is performed by a given capacitor. In an optimum capacitor which is wholly non-conductive, zero current flow will occur across the capacitor. Thus, in view of an idealised capacitor circuit, the object of the water capacitor circuit is to prevent electron flow through the circuit, i.e. such as occurs by electron flow or leakage through a resistive element that produces heat. Electrical leakage in water will occur, however, because of some residual conductivity and impurities, or ions that may otherwise be present in the water. thus, the water capacitor is preferably chemically inert. An electrolyte is not added to the water.

In the isolated water bath, the water molecule takes on charge, and the charge increases. The object of the process is to switch off the co-valent bonding of the water molecule and interrupt the sub-atomic force that binds the hydrogen and oxygen atoms together to form a molecule, thus causing the hydrogen and oxygen to separate.

Because an electron will only occupy a certain electron shell, the voltage applied to the capacitor affects the electrical forces inherent in the co-valent bond. As a result of the charge applied by the plates, the applied force becomes greater than the force of the co-valent bonds between the atoms of the water molecule, and the water molecule becomes elongated. When this happens, the time share ratio of the electrons between the atoms and the electron shells, is modified.

In the process, electrons are extracted from the water bath; electrons are not consumed nor are electrons introduced into the water bath by the circuit, as electrons would be during conventional electrolysis. Nevertheless, a leakage current through the water may occur. Those hydrogen atoms missing electrons become neutralised and atoms are liberated from the water. The charged atoms and electrons are attracted to opposite polarity voltage zones created between the capacitor plates. The electrons formerly shared by atoms in the water co-valent bond are re-allocated so that neutral elemental gasses are liberated.

In the process, the electrical resonance may be reached at all levels of voltage potential. The overall circuit is characterised as a "resonant charging choke" circuit which is an inductor in series with a capacitor [*SAMS Modern Dictionary of Electronics*, 1984 p.859]. Such a resonant charging choke is on each side of the capacitor. In the circuit, the diode acts as a switch which allows the magnetic field produced in the inductor to collapse, thereby doubling the pulse frequency and preventing the capacitor from discharging. In this manner, a continuous voltage is produced across the capacitor plates in the water bath and the capacitor does not discharge. The water molecules are thus subjected to a continuously charged field until the breakdown of the co-valent bond occurs.

As noted initially, the capacitance depends on the dielectric properties of the water and the size and separation of the conductive elements forming the water capacitor.

Example 1

In an example of the circuit of **Fig.2** (in which other circuit element specifications are provided above), two concentric cylinders 4 inches long, formed the water capacitor of the fuel cell in the volume of water. The outside cylinder was 0.75 in outside diameter; the inner cylinder was 0.5 inch in outside diameter. Spacing between the inside cylinder and the outside cylinder was 0.0625 inch (1.59 mm). Resonance in the circuit was achieved at a 26 volt pulse applied to the primary coil of the torroid at 10khz and a gas mixture of hydrogen, oxygen and dissolved gasses was given off. The additional gasses included nitrogen and argon from air dissolved in the water.

In achieving resonance in any circuit, as the pulse frequency is adjusted, the current flow is minimised and the voltage on the capacitor plates is maximised. Calculation of the resonant frequency of an overall circuit is determined by known means; different cavities have a different resonant frequency. The gas production rate is varied by the period of time between trains of pulses, pulse amplitude, capacitor plate size and plate separation.

The wiper arm on the second inductor tunes the circuit and allows for contaminants in the water so that the charge is always applied to the capacitor. The voltage applied, determines the rate of breakdown of the molecule into its atomic components. As water in the cell is consumed, it is replaced by any appropriate means or control system.

Thus, in the first stage, which is of itself independently useful, a fuel gas mixture is produced having, in general, the components of elemental hydrogen and oxygen and some additional atmospheric gasses. The fuel gas is itself combustible in a conventional manner.

After the first stage, the gas atoms become elongated during electron removal as the atoms are ionised. Laser or light wave energy of a predetermined frequency is injected into a containment vessel in a gas ionisation process. The light energy absorbed by voltage-stimulated gas nuclei, causes destabilisation of gas ions still further. The absorbed laser energy causes the gas nuclei to increase in energy state, which in turn, causes electron deflection to a higher orbital shell.

The electrically charged and laser-primed combustible gas ions from a gas resonant cavity, may be directed into an optical thermal lens assembly for triggering. Before entry into the optimal thermal lens, electrons are stripped from the ions and the atom is destabilised. The destabilised gas ions which are electrically and mass unbalanced atoms having highly energised nuclei, are pressurised during spark ignition. The unbalanced, destabilised atomic components interact thermally; the energised and unstable hydrogen gas nuclei collide with highly energised and unstable oxygen gas nuclei, causing and producing thermal explosive energy beyond the gas burning stage. The ambient air gas components in the initial mixture aid the thermal explosive process under a controlled state.

In the process, the point of optimum energy yield is reached when the electron-deficient oxygen atoms (having less than a normal number of electrons) lock on to and capture a hydrogen atom electron, prior to, or during, thermal combustion of the hydrogen/oxygen mixture. Atomic decay results in the release of energy.

After the first stage, the gas mixture is subjected to a pulsating, polar electric field which causes the orbits of the electrons of the gas atoms to become distended. The pulsating electrical field is applied at a frequency which resonates with the electrons of the gas atoms. This results in the energy levels of the electrons increasing in cascading incremental steps.

Next, the gas atoms are ionised and subjected to electromagnetic wave energy of the correct frequency to induce further electron resonance in the ion, whereby the energy level of the electron is successively increased. Electrons are extracted from the resonating ions while they are in this increased energy state, and this destabilises the nuclear electron configuration of the ions. This gas mixture of destabilised ions is thermally ignited.

In the apparatus shown in **Fig.4**, water is introduced at inlet **1** into a first stage water fracturing module **2**, such as the water fuel cell described above, in which water molecules are broken down into hydrogen, oxygen and released gasses which were trapped in the water. These gasses may be introduced to a successive stage **3** or other number of like resonant cavities, which are arranged in either a series or parallel combined array. The successive energisation of the gas atoms, provides a cascading effect, successively increasing the voltage stimulation level of the released gasses as they pass sequentially through cavities **2**, **3**, etc. In a final stage, and injector system **4**, of a configuration of the type shown in **Fig.5A** or **Fig.5B**, receives energised atomic and gas particles where the particles are subjected to further energy input, electrical excitation and thermal stimulation, which produces thermal explosive energy **5**, which may be directed through a lens assembly of the type shown in **Fig.5C** to provide a controlled thermal energy output.

A single cell, or battery of cells such as shown in **Fig.3**, provides a fuel gas source for the stages following the first stage. The fuel gas is activated by electromagnetic waves, and electrically charged gas ions of hydrogen and oxygen (of opposite polarity) are expelled from the cascaded cells **2**, **3**, etc. shown in **Fig.4**. The circuit of **Fig.9** may be utilised as a source of ionising energy for the gasses. The effect of cascading, successively increases the voltage stimulation level of the released gasses, which are then directed to the final injector assembly **4**. In the injector assembly, gas ions are stimulated to an even greater energy level. The gasses are continually exposed to a pulsating laser or other electromagnetic wave energy source together with a high-intensity oscillating voltage field which occurs within the cell between electrodes or conductive plates of opposite electrical polarity. A preferred construction material for the plates is a stainless steel T-304 which is non-chemically reactive with water, hydrogen or oxygen. An electrically conductive material inserted in the fluid environment, is a desirable

material of construction for the electrical field producing plates, through which field, the stream of activated gas particles passes.

Gas ions of opposite electrical charges reach and maintain a critical energy level state. The gas ions have opposite electrical charges and are subjected to oscillating voltage fields of opposite polarity. They are also subjected to a pulsating electromagnetic wave energy source. Immediately after reaching critical energy, the excited gas ions are exposed to a high temperature thermal zone in the injection cell **4**, which causes the excited gas ions to undergo gas combustion. The gas ignition triggers atomic decay and releases thermal energy **5**, with explosive force.

Once triggered, the explosive thermal energy output is controllable by the attenuation of operational parameters. With reference to **Fig.6A**, for example, once the frequency of resonance is identified, by varying applied pulse voltage to the initial water fuel cell assemblies **2, 3**, the ultimate explosive energy output is likewise varied. By varying the pulse shape and/or amplitude, or pulse train sequence of the electromagnetic wave energy source, final output is varied. Attenuation of the voltage field frequency in the form of OFF and ON pulses, likewise affects the output of the staged apparatus. Each control mechanism can be used separately, grouped in sections, or systematically arranged in a sequential manner.

A complete system in accordance with the present application thus includes:

1. A water fuel cell for providing a first fuel gas mixture consisting of at least a portion of hydrogen and oxygen gas.
2. An electrical circuit of the type shown in **Fig.7** providing a pulsating, polar electric field to the gas mixture as illustrated in **Fig.6A**, whereby electron orbits of the gas atoms are distended by being subjected to electrical polar forces, changing from the state shown conceptually in **Fig.6B** to that of **Fig.6C**, at a frequency such that the pulsating electric field induces a resonance with respect to electrons of the gas atoms. The energy level of the resonant electrons is thereby increased in cascading incremental steps.
3. A further electric field to ionise the gas atoms and
4. An electromagnetic wave energy source for subjecting the ionised gas atoms to wave energy of a predetermined frequency to induce further electron resonance in the ions, whereby the energy level of the electron is successively increased, as shown in **Fig.6D**.
5. An electron sink, which may be in the form of the grid element shown in **Fig.8A**, extracts further electrons from the resonating ions while such ions are in an increased energy state and destabilises the nuclear electron configuration of the ions. The "extraction" of electrons by the sink is co-ordinated with the pulsating electrical field of the resonant cavity produced by the circuit of **Fig.7**, by means of
6. An interconnected synchronisation circuit, such as shown in **Fig.8B**.
7. A nozzle, **10** in **Fig.5B**, or thermal lens assembly, **Fig.5C**, provides the means to direct the destabilised ions, and in which they are finally thermally ignited.

As previously noted, to reach and trigger the ultimate atomic decay of the fuel cell gasses at the final stage, sequential steps are taken. First, water molecules are slit into hydrogen and oxygen gasses by a voltage stimulation process. In the injector assembly, a laser produced coherent light wave is absorbed by the gasses. At this point, as shown in **Fig.6B**, the individual atoms are subjected to an electric field to begin an ionisation process. The laser energy is absorbed and causes gas atoms to lose electrons and form positively charged gas ions. The energised, positively charged hydrogen atoms now accept electrons liberated from the heavier gasses and attract other negatively charged gas ions as conceptually illustrated in **Fig.6C**. Positively and negatively charged gas ions are re-exposed to further pulsating energy sources to maintain random distribution of ionised gas particles.

The gas ions within the wave energy chamber are subjected to an oscillating high-intensity voltage field in a chamber **11** in **Fig.5A** and **Fig.5B** formed within electrodes **12** and **13** in **Fig.5A** and **Fig.5B** of opposite electrical polarity, to produce a resonant cavity. The gas ions reach a critical energy state at the point of resonance.

At this point, within the chamber, additional electrons are attracted to the positive electrode; while positively charged ions or atomic nuclei are attracted to the negative electrode. The positive and negative attraction forces are co-ordinated and act on the gas ions simultaneously; the attraction forces are non-reversible. The gas ions experience atomic component deflection approaching the point of electron separation. At this point electrons are extracted from the chamber by a grid system such as shown in **Fig.5A**. The extracted electrons are consumed and prevented from re-entering the chamber by a circuit such as shown in **Fig.8B**. The elongated gas ions are subjected to a thermal heat zone to cause gas ignition, releasing thermal energy with explosive force. During ionic gas combustion, highly energised and stimulated atoms and atom nuclei collide and explode during thermal excitation. The hydrogen fracturing process occurring, sustains and maintains a thermal zone, at a temperature in excess of normal oxygen/hydrogen combustion temperature, that is, in excess of 2,500 degrees Fahrenheit. To cause and maintain the atomic elongation depicted in **Fig.6C** before gas ignition, a voltage intensifier circuit such

as shown in **Fig.7** is utilised as a current-restricting voltage source to provide the excitation voltage applied to the resonant cavity. At the same time, the interconnected electron extractor circuit shown in **Fig.8B**, prevents the reintroduction of electrons back into the system. depending on calculated design parameters, a predetermined voltage and frequency range may be designed for any particular application or physical configuration of the apparatus.

In the operation of the assembly, the pulse train source for the gas resonant cavity shown at **2** and **3** in **Fig.4** may be derived from a circuit such as shown in Figs. **2**, **7** or **9**, and such cavity circuits may be in sequence to provide a cascading energy input. It is necessary in the final electron extraction, that the frequency with which electrons are removed from the system be sequenced and synchronised with the pulsing of the gas resonant cavity. In the circuit of **Fig.8B**, the co-ordination of synchronisation of the circuit with the circuit of **Fig.7** may be achieved by interconnecting point "A" of the gate circuit of **Fig.8B** to point "A" of the pulsing circuit of **Fig.7**.

The circuit shown in **Fig.9** enhances the voltage potential across the resonant charging choke coils during pulsing operations and restricts current flow by allowing an external electromagnetic pulsing field **F**, derived from the primary coil **A** being energised to traverse the coil windings **D** and **E** being energised by the incoming pulse train **Ha xxx Hn**, through switching diode **G**. The external pulse field **F**, and the incoming pulse train **Ha xxx Hn**, are sequentially the same, allowing resonant action to occur, restricting current flow while allowing voltage intensity to increase to stimulated the electrical polarisation process, the gas ionisation process and the electron extraction process. The voltage intensifier circuit of **Fig.9** prevents electrons from entering into those processes.

Together, the hydrogen injector assembly **4**, and the resonant cavity **2** and **3**, form a gas injector fuel cell which is compact, low in weight and whose design can be varied. For example, the hydrogen injector system is suited for cars and jet engines. Industrial applications require larger systems. For rocket engine applications, the hydrogen gas injector system is positioned at the top of each resonant cavity arranged in a parallel cluster array. If resonant cavities are sequentially combined in a parallel/series array, the hydrogen injection assembly is positioned after the exits of the resonant cavities have been combined.

From the outline of the physical phenomena associated with the process described in **Table 1**, the theoretical basis of the invention considers the respective states of molecules, gasses and ions derived from liquid water. Before voltage stimulation, water molecules are randomly dispersed throughout water within a container. When a unipolar voltage pulse train such as shown in **Fig.6A (53a xxx 53n)** is applied, an increasing voltage potential is induced in the molecules, gasses and/or ions in a linear, step-like charging effect. The electrical field of the particles within a chamber including the electrical field plates increases from a low-energy state (**A**) to a high-energy state (**J**) in a step manner, following each pulse train as illustrated in **Fig.6A**. The increasing voltage potential is always positive in direct relationship to negative ground potential during each pulse. The voltage polarity on the plates which create the voltage fields, remains constant. Positive and negative voltage "zones" are thus formed simultaneously.

In the first stage of the process described in **Table 1**, because the water molecule naturally exhibits opposite electric fields in a relatively polar configuration (the two hydrogen atoms are positively electrically charged relative to the negatively electrically charged oxygen atom), the voltage pulse causes initially randomly orientated water molecules in the liquid state to spin and orientate themselves with reference to the voltage fields applied.

When the potential difference applied causes the oriented water molecules to align themselves between the conductive plates, pulsing causes the voltage field intensity to be increased in accordance with **Fig.6A**. As further molecular alignment occurs, molecular movement is hindered. Because the positively charged hydrogen atoms are attracted in the opposite direction to the negatively charged oxygen atoms, a polar charge alignment or distribution occurs as shown in **Fig.6B**. As the energy level of the atoms subjected to resonant pulsing increases, the stationary water molecules become elongated as shown in **Fig.6C**. Electrically charged nuclei and electrons are attracted towards opposite voltage zones, disrupting the mass equilibrium of the water molecule.

In the first stage, as the water molecule is further exposed to a potential difference, the electrical force of attraction of the atoms to the chamber electrodes also increases in intensity. As a result, the co-valent bonding between the atoms is weakened and ultimately, terminated. The negatively charged electron is attracted towards the positively charged hydrogen atoms, while at the same time, the negatively charged oxygen atoms repel electrons.

Once the applied resonant energy caused by pulsation of the electrical field in the cavities reaches a threshold level, the disassociated water molecules, now in the form of liberated hydrogen, oxygen and ambient air gasses, begin to ionise and lose or gain electrons during the final stage in the injector assembly. Atom destabilisation occurs and the electrical and mass equilibrium of the atoms is disrupted. Again, the positive field produced within the chamber or cavity that encompasses the gas stream, attracts negatively charged ions while the positively charged ions are attracted to the negative field. Atom stabilisation does not occur because the pulsing voltage

applied is repetitive without polarity change. A potential of approximately several thousand volts, triggers the ionisation state.

As the ionised particles accumulate within the chamber, the electrical charging effect is again an incremental stepping effect that produces an accumulative increased potential, while, at the same time, resonance occurs. The components of the atom begin to "vibrate" at a resonant frequency such that an atomic instability is created. As shown in **Fig.6D**, a high energy level is achieved, which then collapses, resulting in the release of thermal explosive energy. Particle impact occurs when liberated ions in a gas are subjected to further voltage. A longitudinal cross-section of a gas resonant cavity is shown in **Fig.5A**. To promote gas ionisation, electromagnetic wave energy such as a laser or photon energy source of a predetermined wavelength and pulse intensity is directed to, and absorbed by, the ions of the gas. In the device of **Fig.5A**, semiconductor optical lasers **20a - 20p**, **20xxx** surround the gas flow path. In the device of **Fig.5B**, photo energy **20** is injected into a separate absorption chamber **21**. The incremental stimulation of nuclei to a more highly energised state by electromagnetic wave energy causes electron deflection to a higher orbital state. The pulse rate as well as intensity of the electromagnetic wave source is varied to match the absorption rate of ionised particles to produce the stepped incremental increase in energy. A single laser coupled by means of fibre optic light guides is an alternative to the plurality of lasers shown in **Fig.5B**. Continued exposure of the gas ions to different forms of wave energy during voltage stimulation, maintain individual atoms in a destabilised state and prevents atomic stabilisation.

The highly energised gas ions are thermally ignited when they pass from injector **4** and enter into and pass through a nozzle **10** in **Fig.5B**, or an optical thermal lens assembly as shown in **Fig.5C**. In **Fig.5C**, the combustible gas ions are expelled through and beyond a quenching circuit **30**, and reflected by lenses **31** and **32**, back and forth through a thermal heat zone **33**, prior to atomic breakdown and then exiting through a final port **34**. A quenching circuit is a restricted orifice through which the particle stream passes, such that flashback does not occur. The deflection shield or lens **31**, superheats beyond 3000 degrees Fahrenheit and the combustible gas ions passing through the exiting ports are regulated to allow a gas pressure to form inside the thermal zone. The energy yield is controlled by varying the applied voltage or pulse-train since the thermal-lens assembly is self-adjusting to the flow rate of the ionised and primed gasses. The combustible ionic gas mixture is composed of hydrogen, oxygen and ambient air gasses. The hydrogen gas provides the thermal explosive force, the oxygen atoms aid the gas thermal ignition, and the ambient air gasses retard the gas thermal ignition process to a controllable state.

As the combustible gas mixture is exposed to a voltage pulse train, the stepped increasing voltage potential causes the moving gas atoms to become ionised (losing or gaining electrons) and changes the electrical and mass equilibrium of the atoms. Gasses which do not undergo the gas ionisation process may accept the liberated electrons (electron entrapment) when exposed to light or photon stimulation. The electron extractor grid circuit shown in **Fig.8A** and **Fig.8B**, is applied to the assembly of **Fig.5A** or **Fig.5B**, and restricts electron replacement. The extractor grid **56**, is applied adjacent to electric field producing components **44** and **45**, within the resonant cavity. The gas ions incrementally reach a critical state which occurs after a high energy resonant state. At this point, the atoms no longer tolerate the missing electrons, the unbalanced electrical field and the energy stored in the nucleus. Immediate collapse of the system occurs and energy is released as the atoms decay into thermal explosive energy.

The repetitive application of a voltage pulse train (**A** through **J** of **Fig.6A**) incrementally achieves the critical state of the gas ions. As the gas atoms or ions (**1a xxx 1n**) shown in **Fig.6C**, become elongated during electron removal, electromagnetic wave energy of a predetermined frequency and intensity is injected. The wave energy absorbed by the stimulated gas nuclei and electrons, causes further destabilisation of the ionic gas. The absorbed energy from all sources, causes the gas nuclei to increase in energy state and induces the ejection of electrons from the nuclei.

To further stimulate the electron entrapment process beyond the atomic level (capturing the liberated electrons during the hydrogen fracturing process), the electron extractor grid (as shown in **Fig.8A**) is placed in spaced relationship to the gas resonant cavity structure shown in **Fig.5A**. The electron extractor grid is attached to an electrical circuit (such as that shown in **Fig.8B**) which allows electrons to flow to an electrical load **55**, when a positive electrical potential is placed on the opposite side of the electrical load. The electrical load may be a typical power-consuming device such as a light bulb or resistive heat-producing device. As the positive electrical potential is switched on, or pulse-applied, the negatively charged electrons liberated in the gas resonant cavity, are drawn away and enter into the resistive load where they are released as heat or light energy. The consuming electrical circuit may be connected directly to the gas resonant cavity positive electrical voltage zone. The incoming positive wave form applied to the resonant cavity voltage zone through a blocking diode, is synchronised with the pulse train applied to the gas resonant cavity by the circuit of **Fig.7** via an alternate gate circuit. As one pulse train is gated "ON", the other pulse train is switched "OFF". A blocking diode directs the electron flow to the electrical load, while resistive wire prevents voltage leakage during the pulse train "ON" time.

The electron extraction process is maintained during gas-flow change by varying the trigger pulse rate in relationship to the applied voltage. The electron extraction process also prevents spark-ignition of the combustible gasses travelling through the gas resonant cavity because electron build-up and potential sparking is prevented.

In an optical thermal lens assembly or thrust-nozzle, such as shown in **Fig.5C**, destabilised gas ions (electrically and mass unbalanced gas atoms having highly energised nuclei) can be pressurised during spark ignition. During thermal interaction, the highly energised and unstable hydrogen gas nuclei collide with the highly energised and unstable oxygen gas nuclei and produce thermal explosive energy beyond the gas-burning stage. Other ambient air gasses and ions not otherwise consumed, limit the thermal explosive process.

WATER FUEL INJECTION SYSTEM

ABSTRACT

An injector system comprising an improved method and apparatus useful in the production of a hydrogen containing fuel gas from water in a process in which the dielectric property of water and/or a mixture of water and other components determines a resonant condition that produces a breakdown of the atomic bonding of atoms in the water molecule. The injector delivers a mixture of water mist, ionised gases and non-combustible gas to a zone within which the breakdown process leading to the release of elemental hydrogen from the water molecules occurs.

DESCRIPTION

This invention relates to a method and apparatus useful in producing thermal combustive energy from the hydrogen component of water.

In my patent no. 4,936,961 "Method for the Production of a Fuel Gas", I describe a water fuel cell which produces a gas energy source by a method which utilises water as a dielectric component of a resonant electrical circuit.

In my patent no. 4,826,581 "Controlled Process for the Production of Thermal Energy From Gasses and Apparatus Useful Therefore", I describe a method and apparatus for obtaining the enhanced release of thermal energy from a gas mixture including hydrogen and oxygen in which the gas is subjected to various electrical, ionising and electromagnetic fields.

In my co-pending application serial no. 07/460,859 "Process and Apparatus for the Production of Fuel Gas and the Enhanced Release of Thermal Energy from Fuel Gas", I describe various means and methods for obtaining the release of thermal/combustive energy from the hydrogen (H) component of a fuel gas obtained from the disassociation of a water (H₂O) molecule by a process which utilises the dielectric properties of water in a resonant circuit; and in that application I more thoroughly describe the physical dynamics and chemical aspects of the water-to-fuel conversion process.

The invention of this present application represents generational improvement in methods and apparatus useful in the utilisation of water as a fuel source. In brief, the present invention is a microminiaturised water fuel cell which permits the direct injection of water, and its simultaneous transformation into a hydrogen-containing fuel, in a combustion zone, such as a cylinder in an internal combustion engine, a jet engine or a furnace. Alternatively, the injection system of the present invention may be utilised in any non-engine application in which a concentrated flame or heat source is desired, for example: welding.

The present injection system eliminates the need for an enclosed gas pressure vessel in a hydrogen fuel system and thereby reduces a potential physical hazard heretofore associated with the use of hydrogen-based fuels. The system produces fuel-on-demand in real-time operation and sets up an integrated environment of optimum parameters so that a water-to-fuel conversion process works at high efficiency.

The preferred embodiment of the invention is more fully explained below with reference to the drawings in which:

Fig.1 figuratively illustrates the sections and operating zones included in a single injector of the invention.

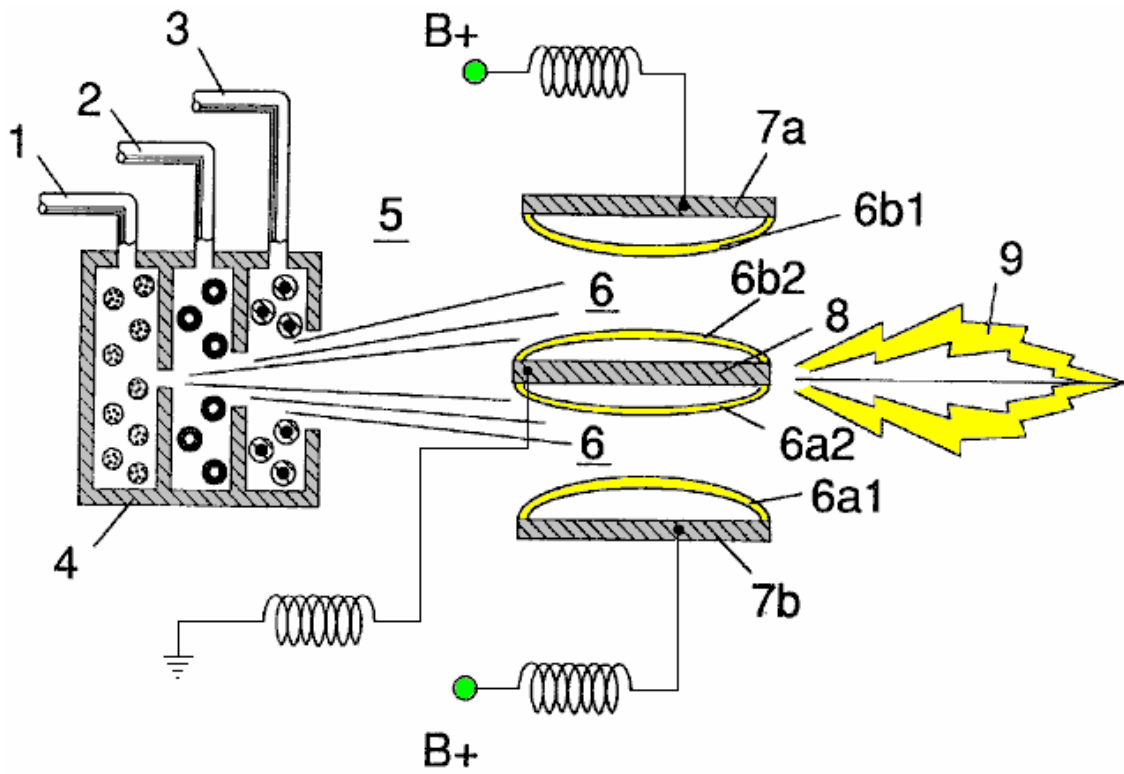

Fig.2A is a side cross-sectional view.

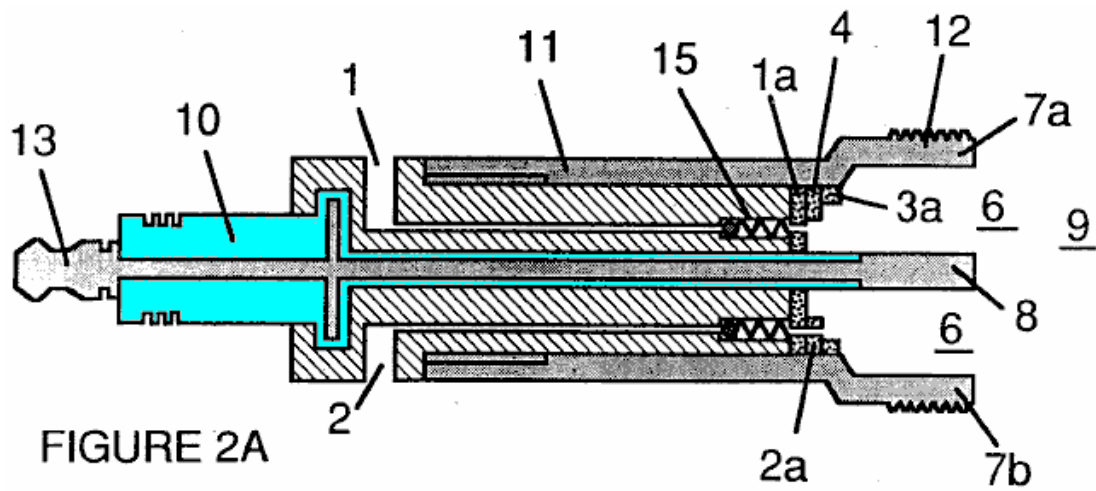

Fig.2B is a frontal view from the operative end.

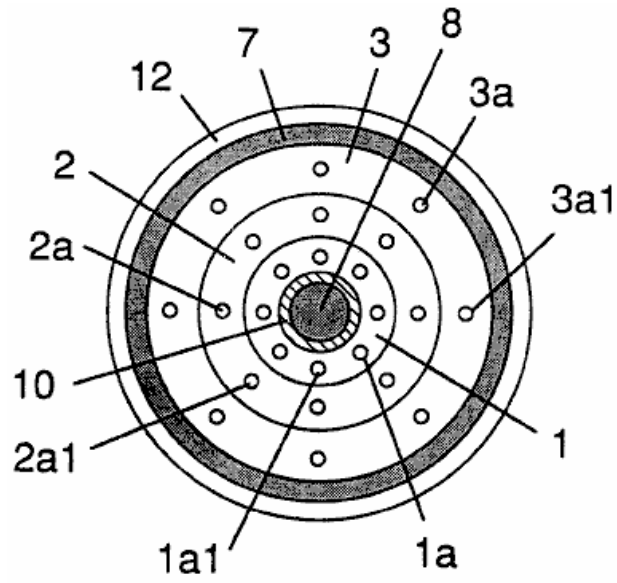

FIGURE 2B

Fig.2C is an exploded view of an individual injector.

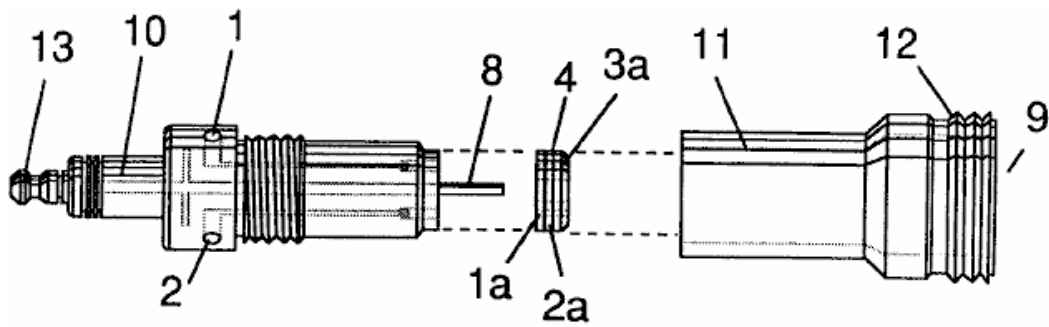

FIGURE 2C

Fig.3 and Fig.3A show the side and frontal cross-sectional views of an alternatively configured injector.

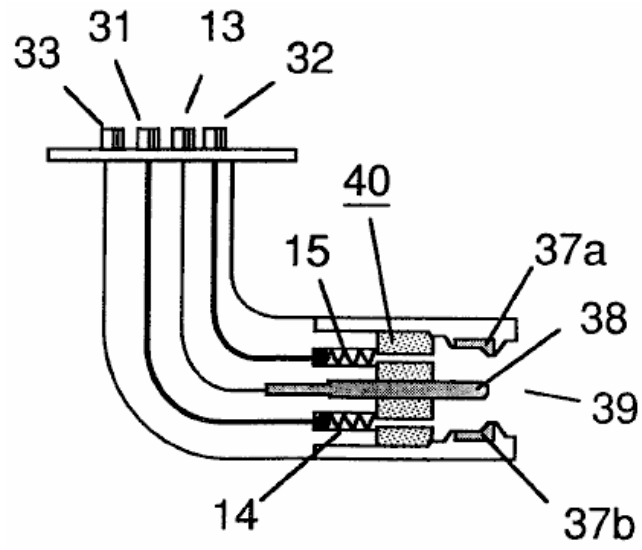

FIGURE 3

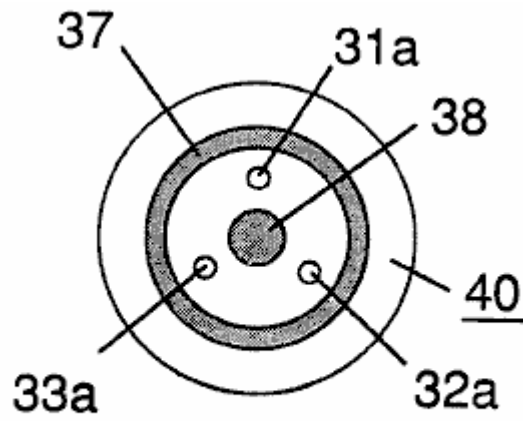

FIGURE 3A

Fig.4 shows a disk array of injectors.

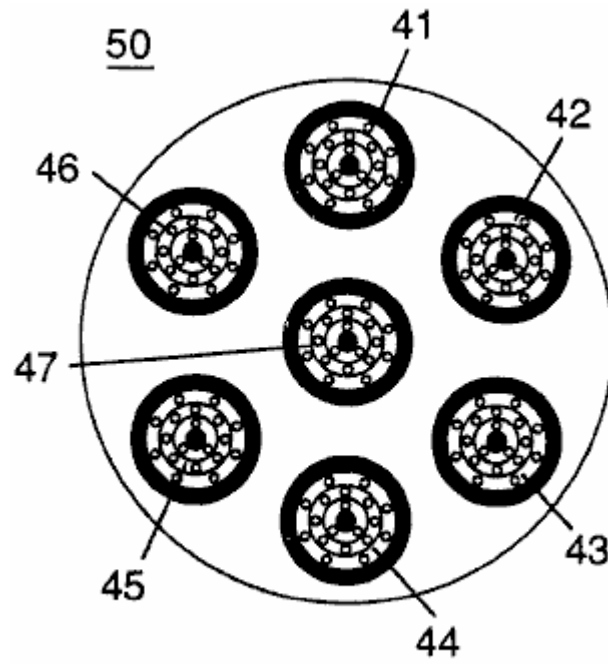

FIGURE 4

Fig.5 shows the resonance electrical circuit including the injector.

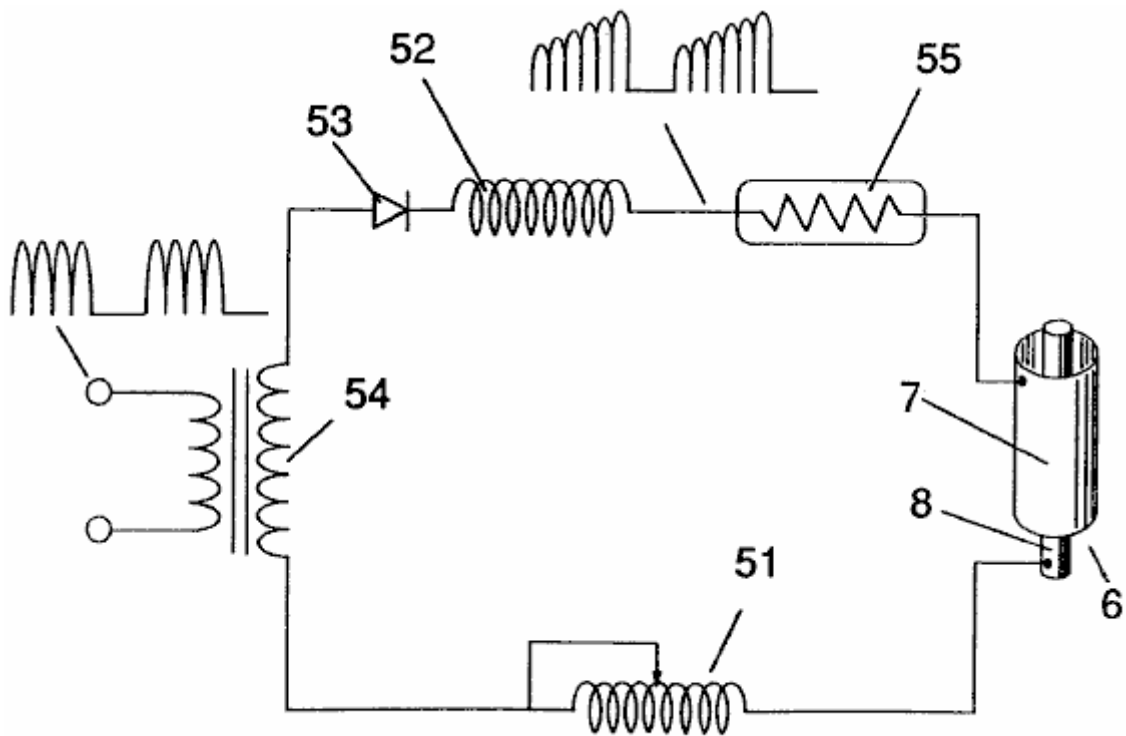

FIGURE 5

Fig.6 depicts the inter-relationship of the electrical and fuel distribution components of an injector system.

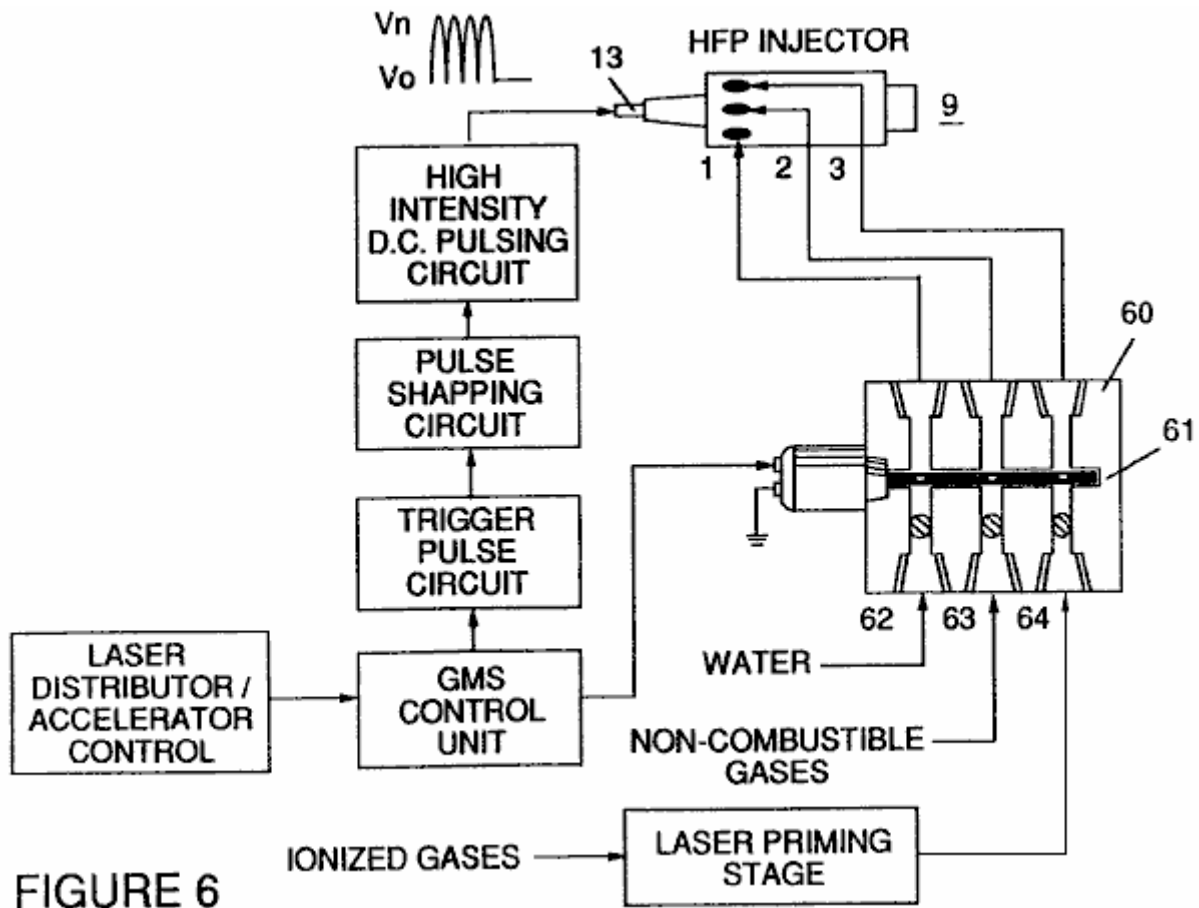

FIGURE 6

Although I refer to an “injector” in this document, the invention relates not only to the physical configuration of an injector apparatus, but also to the overall process and system parameters determined in the apparatus to achieve the release of thermal energy. In a basic outline, an injector regulates the introduction of process constituents into a combustion zone and sets up a fuel mixture condition permitting combustion. That combustion condition is triggered simultaneously with injector operation in real-time correspondence with control parameters for the process constituents.

In the fuel mixture condition which is created by the injector, water (H_2O) is atomised into a fine spray and mixed with 1 ionised ambient air gasses and 2 other non-combustible gasses such as nitrogen, argon and other rare gasses, and water vapour. (Exhaust gas produced by the combustion of hydrogen with oxygen is a non-combustible water vapour. This water vapour and other inert gasses resulting from combustion may be recycled from an exhaust outlet in the injector system, back into the input mixture of non-combustible gasses.) The fuel mix is introduced at a consistent flow rate maintained under a predetermined pressure. In the triggering of the condition created by the injector, the conversion process described in my patent no. 4,936,961 and co-pending application serial no. 07/460,859 is set off spontaneously on a “micro” level in a predetermined reaction zone. The injector creates a mixture, under pressure in a defined zone of water, ionised gasses and non-combustible gasses. Pressure is an important factor in the maintenance of the reaction condition and causes the water/gas mixture to become intimately mixed, compressed and destabilised to produce combustion when activated under resonance conditions of ignition. In accordance with the earlier mentioned conversion process of my patent and application, when water is subjected to a resonance condition water molecules expand and distend; electrons are ejected from the water molecule and absorbed by ionised gasses and the water molecule, thus destabilised, breaks down into its elemental components of hydrogen (H_2) and oxygen (O) in the combustion zone. The hydrogen atoms released from the molecule provide the fuel source in the mixture for combustion with oxygen. The present invention is an application of that process and is outlined in Table 1:

Table 1

<u>Injector Mixture</u>	+	<u>Process conditions</u>	=	<u>Thermal Energy</u>
(1) Water Mist		(1) Release Under pressure into Combustion Zone		(1) Heat
and		and		or
(2) Ionised Gas		(2) Resonance utilising the dielectric property of water as a capacitor		(2) Internal Combustion Engine (Explosive force)
and		and		or
(3) Non-combustible Gas		(3) Unipolar pulsing at high voltage		(3) Jet Engine
				or
				(4) Other application

The process occurs as water mist and gasses under pressure are injected into, and intimately mixed in the combustion zone and an electrically polarised zone. In the electrically polarised zone, the water mixture is subjected to a unipolar pulsed direct current voltage which is tuned to achieve resonance in accordance with the electrical, mass and other characteristics of the mixture as a dielectric in the environment of the combustion zone. The resonant frequency will vary according to the injector configuration and depends upon the physical characteristics, such as the mass and volume of the water and gasses in the zone. As my prior patents and application point out, the resonant condition in the capacitive circuit is determined by the dielectric properties of water: (1) as the dielectric in a capacitor formed by adjacent conductive surfaces, and (2) as the water molecule itself is a polar dielectric material. At resonance, current flow in the resonant electrical circuit will be minimised and voltage will peak.

The injector system provides a pressurised fuel mixture for subjection to the resonant environment of the voltage combustion zone as the mixture is injected into the zone. In a preferred embodiment, the injector includes concentrically nested serial orifices, one for each of the three constituent elements of the fuel mixture. (It may be feasible to combine and process non-combustible and ionised gasses in advance of the injector. In this event, only two orifices are required, one for the water and the other for the combined gasses.) The orifices disperse the water mist and gasses under pressure into a conically shaped activation and combustion zone.

Fig1A shows a transverse cross-section of an injector, in which, supply lines for water **1**, ionised gas **2**, and non-combustible gas **3**, feed into a distribution disk assembly **4** which has concentrically nested orifices. The fuel mixture passes through a mixing zone **5**, and a voltage zone **6**, created by electrodes **7a** and **7b** (positive) and **8** (negative or ground). Electrical field lines are shown as **6a1** and **6a2** and **6b1** and **6b2**. Combustion (i.e. the oxidation of hydrogen) occurs in the zone **9**. Ignition of the hydrogen can be primed by a spark or may occur spontaneously as a result of the exceptionally high volatility of hydrogen and its presence in a high-voltage field.

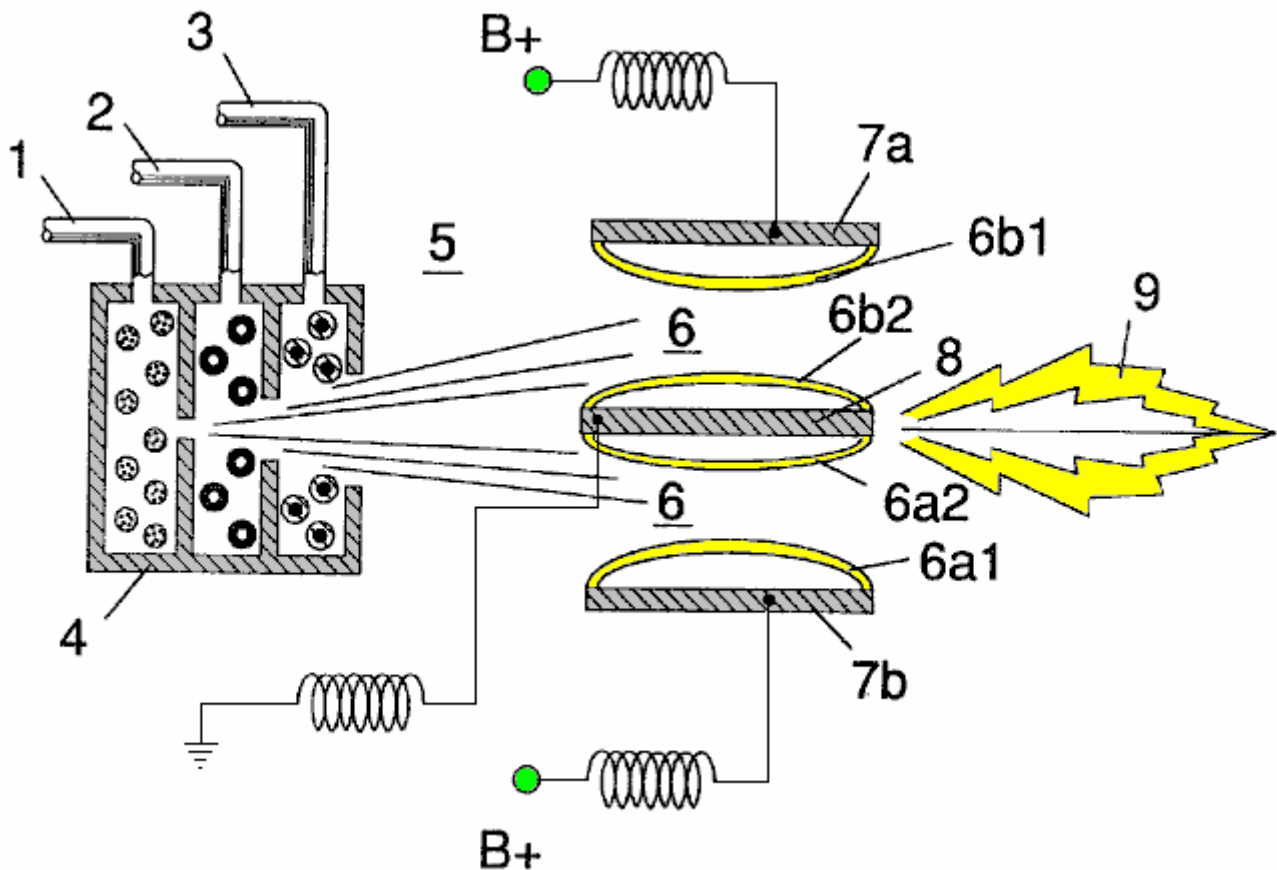

Although the mixing zone, the voltage zone and the combustion zone are mentioned separately in this explanation, they are not in fact physically separated, as can be seen from **Fig.1**. In the zone(s), there is produced an “excited” mixture of vaporised water mist, ionised gasses and other non-combustible gasses, all of which have been instantaneously released from under high pressure. Simultaneously, the released mixture in the zone, is exposed to a pulsed voltage at a frequency corresponding to electrical resonance. Under these conditions, outer-shell electrons of atoms in the water molecule are de-stabilised and molecular time-share is interrupted. Thus, the gas mixture in the injector zone is subjected to physical, electrical and chemical interactive forces which cause a breakdown of the atomic bonding forces of the water molecule.

Process parameters are determined, based on the size of a particular injector. In an injector sized appropriately for use to provide a fuel mixture to a conventional cylinder in a passenger vehicle car engine, the injector may resemble a conventional spark plug. In such an injector, the water orifice is 0.1 to 0.15 inch in diameter; the ionised gas orifice is 0.15 to 0.2 inch in diameter, and the non-combustible gas orifice is 0.2 to 0.25 inch in diameter. In such a configuration, the serial orifices increase in size from the innermost orifice, as appropriate in a concentric configuration. As noted above, it is desirable to maintain the introduction of the fuel components at a constant rate. Maintaining a back-pressure of about 125 pounds per square inch for each of the three fuel gas constituents appears to be satisfactory for a “spark-plug” injector. In the pressurised environment of the injector, spring-loaded one-way check valves in each supply line, such as **14** and **15**, maintain pressure during pulse off times.

Voltage zone **6** surrounds the pressurised fuel mixture and provides an electrically charged environment of pulsed direct current in the range from about 500 to 20,000 volts and more, at a frequency tuned into the resonant characteristic of the mixture. this frequency will typically lie within the range from about 20 KHz to about 50 KHz, dependent, as noted above, on the mass flow of the mixture from the injector and the dielectric property of the mixture. In a spark-plug sized injector, the voltage zone will typically extend longitudinally about 0.25 to 1.0 inch to permit sufficient dwell time of the water mist and gas mixture between the conductive surfaces **7** and **8** which form a capacitor so that resonance occurs at a high-voltage pulsed frequency, and combustion is triggered. In the zone, an energy wave which is related to the resonant pulse frequency, is formed. The wave continues to pulse through the flame in the combustion zone. The thermal energy produced is released as heat energy. In a confined zone such as a piston/cylinder engine, gas detonation under resonant conditions, produces explosive physical power.

In the voltage zone, the time-share ratio of the hydrogen and oxygen atoms comprising the individual water molecules in the water mist, is upset in accordance with the process explained in my patent no. 4,936,961 and application serial no. 07/460,859. Namely, the water molecule, which is itself a polar structure, is distended or

distorted in shape by being subjected to the polar electric field in the voltage zone. The resonant condition induced in the molecule by the unipolar pulses, upsets the molecular bonding of shell electrons such that the water molecule, at resonance, breaks apart into its constituent atoms. In the voltage zone, the water molecules are excited into an ionised state, and the pre-ionised gas component of the fuel mixture, captures the electrons released from the water molecule. In this manner, at the resonant condition, the water molecule is destabilised and the constituent atomic elements of the molecule 2H and O, are released and the released hydrogen atoms are available for combustion. the non-combustible gasses in the fuel mixture, reduce the burn rate of hydrogen to that of a hydrocarbon fuel such as gasoline (petrol) or kerosene (paraffin), from its normal burn rate which is about 2.5 times that of gasoline. Hence the presence of non-combustible gasses in the fuel mixture, moderates the energy release and the rate at which the free hydrogen and oxygen molecules combine in the combustion process.

The combustion process does not occur spontaneously so the conditions in the zone must be fine-tuned carefully to achieve an optimum input flow rate for water and the gasses corresponding to the maintenance of a resonant condition. The input water mist and gasses may likewise be injected into the zone in a physically pulsed (on/off) manner corresponding to the resonance achieved. In an internal combustion engine, the resonance of the electrical circuit and the physical pulsing of the input mixture may be required to be related to the combustion cycle of the reciprocating engine. In this regard, one or two conventional spark plugs may require a spark cycle tuned in correspondence to the conversion cycle resonance, so that combustion of the mixture will occur. Thus, the input flow, conversion rate and combustion rate are interrelated and optimally, each should be tuned in accordance with the circuit resonance at which conversion occurs.

The injection system of the present invention is suited to retrofit applications in conventionally fuelled gasoline and diesel internal combustion engines and conventionally fuelled jet aircraft engines.

Example 1

Figs 2A, 2B and 2C illustrate a type of injector useful, among other things, as a fuel source for a conventional internal combustion engine. In the cross-section of **Fig.2A**, reference numerals corresponding to the identifying numerals used in **Fig.1** show a supply line for water **1**, leading to first distribution disc **1a** and supply line for ionised gas **2**, leading to second distribution disc **2a**. In the cross-section, the supply line for non-combustible gas **3** leading to distribution disc **3a**, is not illustrated, however, its location as a third line should be self evident. The three discs comprise distribution disc assembly **4**. The supply lines are formed in an electrically insulating body **10**, surrounded by electrically conductive sheath/housing **11** having a threaded end segment **12**.

A central electrode **8**, extends the length of the injector. Conductive elements **7a** and **7b** (**7a** and **7b** depict opposite sides of the diameter in the cross-section of a circular body), adjacent threaded section **12** and electrode **8**, form the electrical polarisation zone **6** adjacent to combustion zone **9**. An electrical connector **13** may be provided at the other end of the injector. (In this document, the term "electrode" refers to the conductive surface of an element forming one side of a capacitor.) In the frontal view of **Fig.2B**, it is seen that each disc making up the distribution disc assembly **9**, includes a plurality of micro-nozzles **1a1**, **2a1**, **3a1**, etc. for the injection of the water and gasses into the polarisation/voltage and combustion zones. The exploded view of **Fig.2C** shows another view of the injector and additionally depicts two supply line inlets **1** and **2**, the third not being shown because of the inability of representing the uniform 120° separation of three lines in a two-dimensional drawing.

In the injector, water mist (forming droplets in the range, for example, of from 10 to 250 microns and above, with size being related to voltage intensity) is injected into the fuel-mixing and polarising zone by way of water spray nozzles **1a1**. The tendency of water to form a "bead" or droplet is a parameter related to droplet mist size and voltage intensity. ionised air gasses and non-combustible gasses, introduced through nozzles **2a1** and **3a1**, are intermixed with the expelling water mist to form a fuel-mixture which enters into voltage zone **6** where the mixture is exposed to a pulsating, unipolar, high-intensity voltage field (typically 20,000 volts at 50 Hz or above, at the resonant condition in which current flow in the circuit (amps) is reduced to a minimum) created between electrodes **7** and **8**.

Laser energy prevents discharge of the ionised gasses and provides additional energy input into the molecular destabilisation process which occurs at resonance. It is preferable that the ionised gasses be subjected to laser (photonic energy) activation prior to their introduction into the zone(s); although, for example, a fibre optic conduit may be useful to channel photonic energy directly into the zone. However, heat generated in the zone may affect the operability of such an alternate configuration. The electrical polarisation of the water molecule and a resonant condition occurs to destabilise the molecular bonding of the hydrogen and oxygen atoms. Combustion energy is then released by spark ignition.

To ensure proper flame projection and subsequent flame stability, pumps for the ambient air, non-combustible gas and water, introduce these components to the injector under static pressure up to and beyond 125 pounds per square inch.

Flame temperature is regulated by controlling the volume flow-rate of each fluid-media in direct relationship to applied voltage intensity. To elevate flame temperature, fluid displacement is increased while the volume flow rate of non-combustible gasses is maintained or reduced and the applied voltage amplitude is increased. To lower flame temperature, the fluid flow rate of non-combustible gasses is increased and pulse voltage amplitude is lowered. To establish a predetermined flame temperature, the fluid media and applied voltage are adjusted independently. The flame-pattern is further maintained as the ignited, compressed, and moving gasses are projected under pressure from the nozzle ports in distribution disc assembly **4** and the gas expands in the zone and is ignited.

In the voltage zone, several functions occur simultaneously to initiate and trigger thermal energy yield. Water mist droplets are exposed to high intensity pulsating voltage fields in accordance with an electrical polarisation process which separates the atoms of the water molecule and causes the atoms to experience electron ejection. The polar nature of the water molecule which facilitates the formation of minute droplets in the mist, appears to cause a relationship between the droplet size and the voltage required to effect the process, i.e. the greater the droplet size, the higher the voltage required. The liberated atoms of the water molecule interact with laser-primed ionised ambient air gasses to cause a highly energised and destabilised mass of combustible gas atoms to ignite thermally. Incoming ambient air gasses are laser primed and ionised when passing through a gas processor, and an electron extraction circuit (**Fig.5**) captures and consumes in sink **55**, ejected electrons, and prevents electron flow into the resonant circuit.

In terms of performance, reliability and safety, ionised air gasses and water fuel liquid do not become volatile until the fuel mixture reaches the voltage and combustion zones. Injected non-combustible gasses retard and control the combustion rate of hydrogen during gas ignition.

In alternate applications, laser-primed ionised liquid oxygen and laser-primed liquid hydrogen stored in separate fuel tanks, can be used in place of the fuel mixture, or liquefied ambient air gasses alone with water can be substituted as a fuel source.

The injector assembly is design variable and is retro-fittable to fossil fuel injector ports conventionally used in jet/rocket engines, grain dryers, blast furnaces, heating systems, internal combustion engines and the like.

Example 2

A flange-mounted injector is shown in cross-section in **Fig.3** which shows the fuel mixture inlets and illustrates an alternative three-nozzle configuration leading to the polarisation (voltage) and combustion zones in which one nozzle **31a**, **32a** and **33a** is provided for each of the three gas mixtures, and connected to supply lines **31** and **32** (**33** is not shown). Electrical polarisation zone **36** is formed between electrode **38** and surrounding conductive shell **37**. The capacitive element of the resonant circuit is formed when the fuel mixture, acting as a dielectric, is introduced between the conductive surfaces of **37** and **38**. **Fig.3A** is a frontal view of the operative end of the injector.

Example 3

Multiple injectors may be arranged in a gang as shown in **Fig.4** in which injectors **40**, **41**, **42**, **43**, **44**, **45**, **46**, **47**, **48** and **49** are arranged concentrically in an assembly **50**. Such a ganged array is useful in applications having intensive energy requirements such as jet aircraft engines and blast furnaces.

Example 4

The basic electrical system utilised in the invention is depicted in **Fig.5** showing the electrical polarisation zone **6** which receives and processes the water and gas mixture as a capacitive circuit element in a resonant charging circuit formed by inductors **51** and **52** connected in series with diode **53**, pulsed voltage source **54**, electron sink **55** and zone **6** formed from conductive elements **7** and **8**. In this manner, electrodes **7** and **8** in the injector, form a capacitor which has electrical characteristics dependent on the dielectric media (e.g. the water mist, ionised gasses and non-combustible gasses) introduced between the conductive elements. Within the macro-dielectric media, however, the water molecules themselves, because of their polar nature, can be considered micro-capacitors.

Example 5

Fuel distribution and management systems useful with the injector of this application are described in my co-pending applications for patent; PCT/US90/6513 and PCT/US90/6407.

A distribution block for the assembly is shown in **Fig.6**. In **Fig.6** the distribution block pulses and synchronises the input of the fuel components in sequence with the electrical pulsing circuit. The fuel components are injected into the injector ports in synchronisation with the resonant frequency, to enhance the energy wave pulse extending from the voltage zone through the flame. In the configuration of **Fig.6**, the electrical system is interrelated to distribution block **60**, gate valve **61** and separate passageways **62**, **63** and **64** for fuel components. The distributor produces a trigger pulse which activates a pulse-shaping circuit that forms a pulse having a width and amplitude determined by resonance of the mixture and establishes a dwell time for the mixture in the zone to produce combustion..

As in my referenced application regarding control and management and distribution systems for a hydrogen-containing fuel gas produced from water, the production of hydrogen gas is related to pulse frequency on/off time. In the system shown in **Fig.6**, the distributor block pulses the fluid media introduced to the injector in relationship to the resonant pulse frequency of the circuit and to the operational on/off gate pulse frequency. In this manner, the rate of water conversion (i.e. the rate of fuel produced by the injector) can be regulated and the pattern of resonance in the flame controlled.

CONTROL AND DRIVER CIRCUITS FOR A HYDROGEN GAS FUEL PRODUCING CELL

The major difficulty in using Stan's low-current Water Fuel Cell (recently reproduced by Dave Lawton and shown in Chapter 10) is the issue of keeping the cell continuously at the resonant frequency point. This patent application shows the Stan's circuitry for doing exactly that, and consequently, it is of major importance.

ABSTRACT

A control circuit for a capacitive resonant cavity water capacitor cell (7) for the production of a hydrogen containing fuel has a resonant scanning circuit co-operating with a resonance detector and PLL circuit to produce pulses. The pulses are fed into the primary transformer (TX1). The secondary transformer (TX2) is connected to the resonant cavity water capacitor cell (7) via a diode and resonant charging chokes (TX4, TX5).

This invention relates to electrical circuit systems useful in the operation of a Water Fuel Cell including a water capacitor/resonant cavity for the production of a hydrogen containing fuel gas, such as that described in my United States Letter Patent No. 4,936,961 "Method for the Production of a Fuel Gas" issued on 26th June 1990.

In my Letters Patent for a "Method for the Production of a Fuel Gas", voltage pulses applied to the plates of a water capacitor tune into the dielectric properties of the water and attenuate the electrical forces between the hydrogen and oxygen atoms of the molecule. The attenuation of the electrical forces results in a change in the molecular electrical field and the covalent atomic bonding forces of the hydrogen and oxygen atoms. When resonance is achieved, the atomic bond of the molecule is broken, and the atoms of the molecule disassociate. At resonance, the current (amp) draw from a power source to the water capacitor is minimised and voltage across the water capacitor increases. Electron flow is not permitted (except at the minimum, corresponding to leakage resulting from the residual conductive properties of water). For the process to continue, however, a resonant condition must be maintained.

Because of the electrical polarity of the water molecule, the fields produced in the water capacitor respectively attract and repel the opposite and like charges in the molecule, and the forces eventually achieved at resonance are such that the strength of the covalent bonding force in the water molecule (which are normally in an electron-sharing mode) disassociate. Upon disassociation, the formerly shared bonding electrons migrate to the hydrogen nuclei, and both the hydrogen and oxygen revert to net zero electrical charge. The atoms are released from the water as a gas mixture.

In the invention herein, a control circuit for a resonant cavity water capacitor cell utilised for the production of a hydrogen-containing fuel gas is provided.

The circuit includes an isolation means such as a transformer having a ferromagnetic, ceramic or other electromagnetic material core and having one side of a secondary coil connected in series with a high speed switching diode to one plate of the water capacitor of the resonant cavity and the other side of the secondary coil connected to the other plate of the water capacitor to form a closed loop electronic circuit utilising the dielectric properties of water as part of the electronic resonant circuit. The primary coil of the isolation transformer is connected to a pulse generation means. The secondary coil of the transformer may include segments which form resonant charging choke circuits in series with the water capacitor plates.

In the pulse generation means, an adjustable resonant frequency generator and a gated pulse frequency generator are provided. A gate pulse controls the number of the pulses produced by the resonant frequency generator sent to the primary coil during a period determined by the gate frequency of the second pulse generator.

The invention also includes a means for sensing the occurrence of a resonant condition in the water capacitor / resonant cavity, which when a ferromagnetic or electromagnetic core is used, may be a pickup coil on the transformer core. The sensing means is interconnected to a scanning circuit and a phase lock loop circuit, whereby the pulsing frequency to the primary coil of the transformer is maintained at a sensed frequency corresponding to a resonant condition in the water capacitor.

Control means are provided in the circuit for adjusting the amplitude of a pulsing cycle sent to the primary coil and for maintaining the frequency of the pulsing cycle at a constant frequency regardless of pulse amplitude. In

addition, the gated pulse frequency generator may be connected to a sensor which monitors the rate of gas production in the cell and controls the number of pulses from the resonant frequency generator sent to the cell in a gated frequency in correspondence with the rate of gas production. The sensor may be a gas pressure sensor in an enclosed water capacitor resonant cavity which also includes a gas outlet. The gas pressure sensor is connected to the circuit to determine the rate of gas production with respect to ambient gas pressure in the water capacitor enclosure.

Thus, a comprehensive control circuit and it's individual components for maintaining and controlling the resonance and other aspects of the release of gas from a resonant cavity water cell is described here and illustrated in the drawings which depict the following:

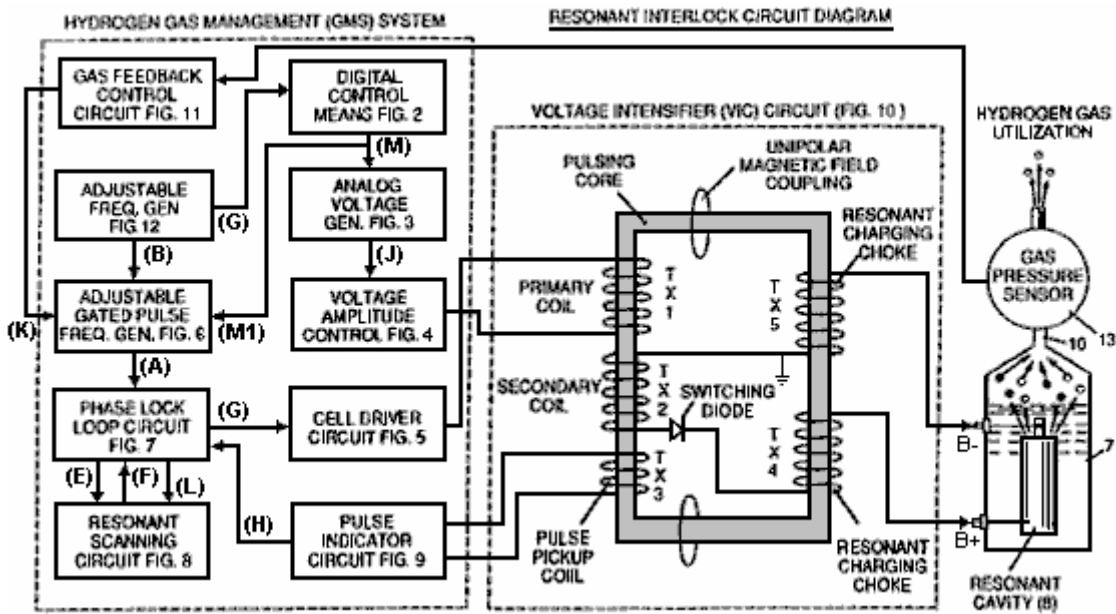

Fig.1 is a block diagram of an overall control circuit showing the interrelationship of sub-circuits, the pulsing core / resonant circuit and the water capacitor resonant cavity.

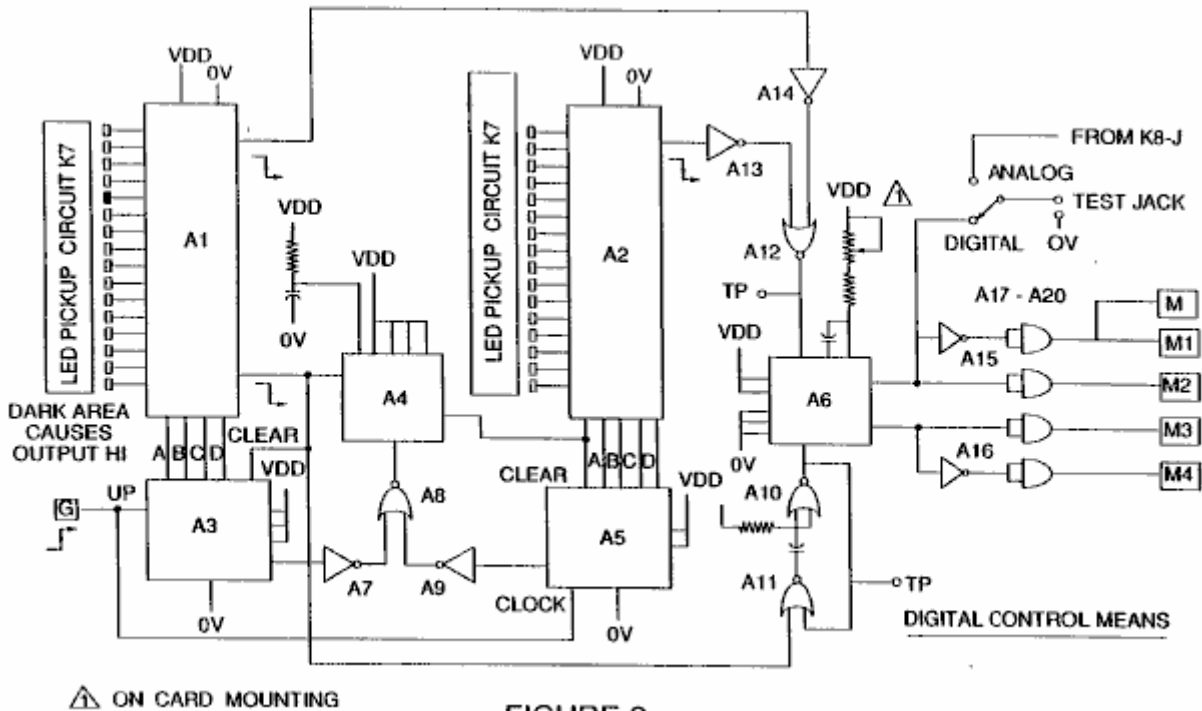

FIGURE 2

Fig.2 shows a type of digital control circuit for regulating the ultimate rate of gas production as determined by an external input. (Such a control circuit would correspond, for example, to the accelerator in a car, or the thermostat control in a building).

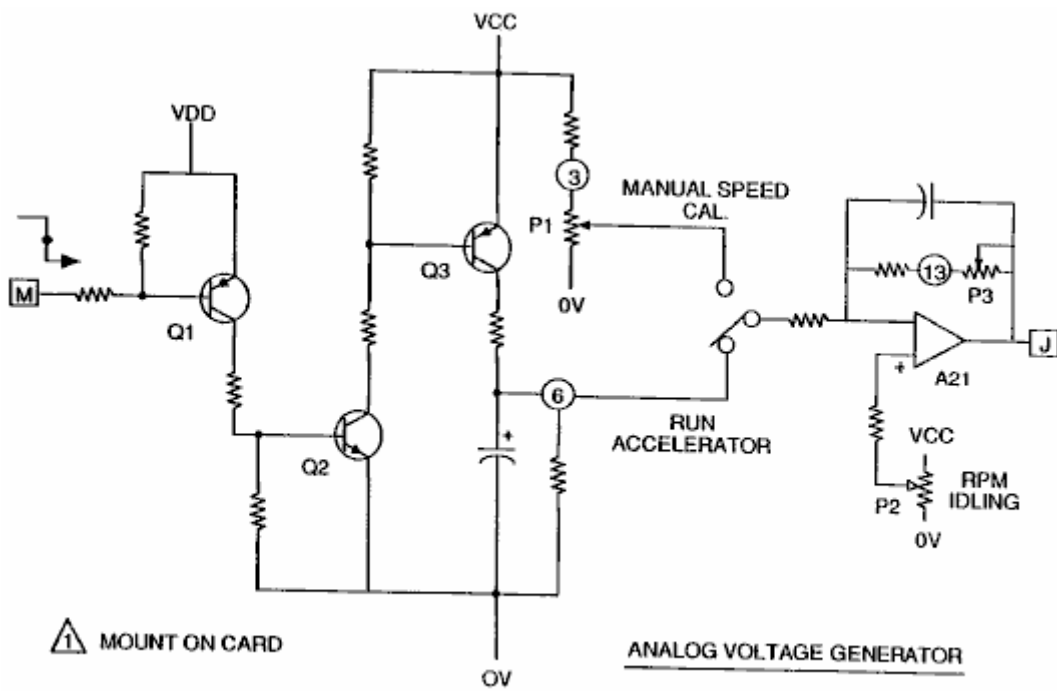

FIGURE 3

Fig.3 shows an analog voltage generator.

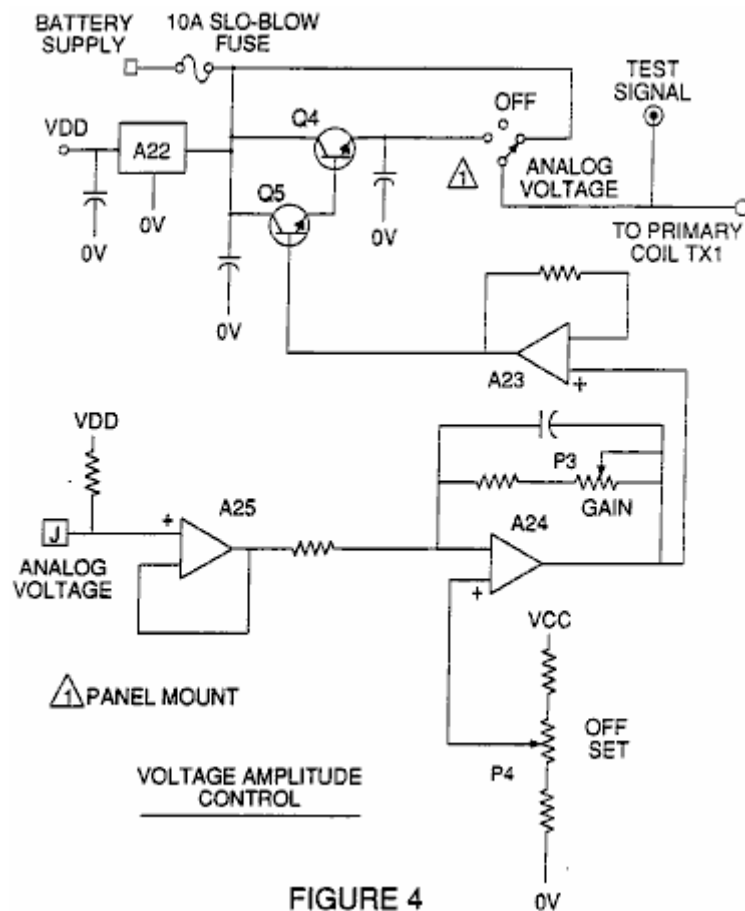

FIGURE 4

Fig.4 is a voltage amplitude control circuit interconnected with the voltage generator and one side of the primary coil of the pulsing core.

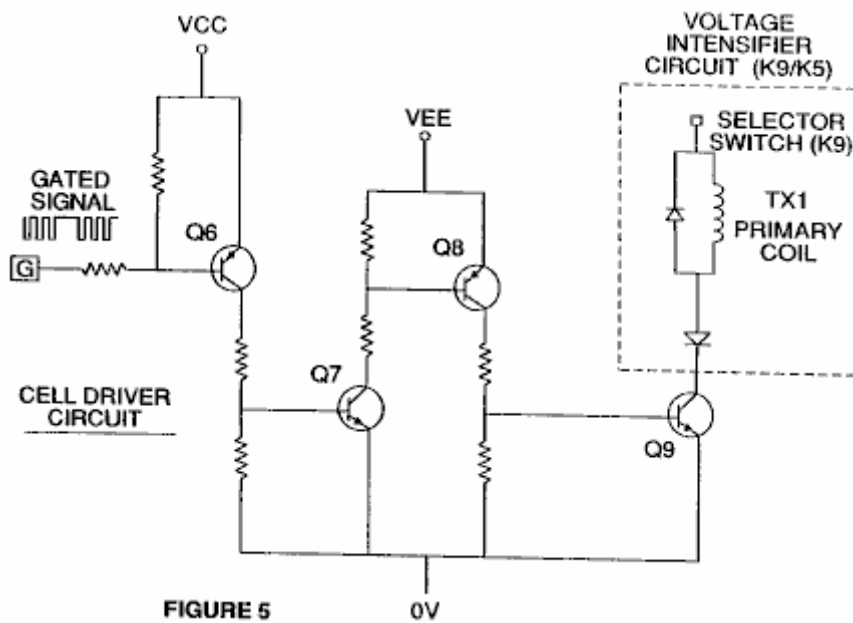

FIGURE 5

Fig.5 is the cell driver circuit that is connected with the opposite side of the primary coil of the pulsing core. **Figures 6 to 9** form the pulsing control circuitry:

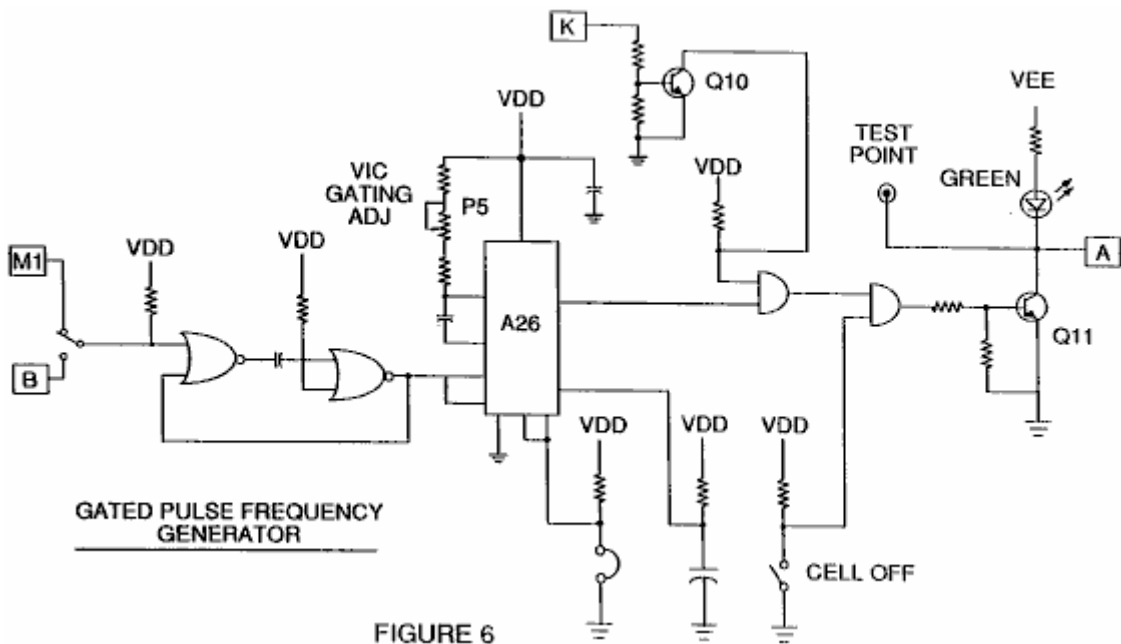

FIGURE 6

Fig.6 is a gated pulse frequency generator.

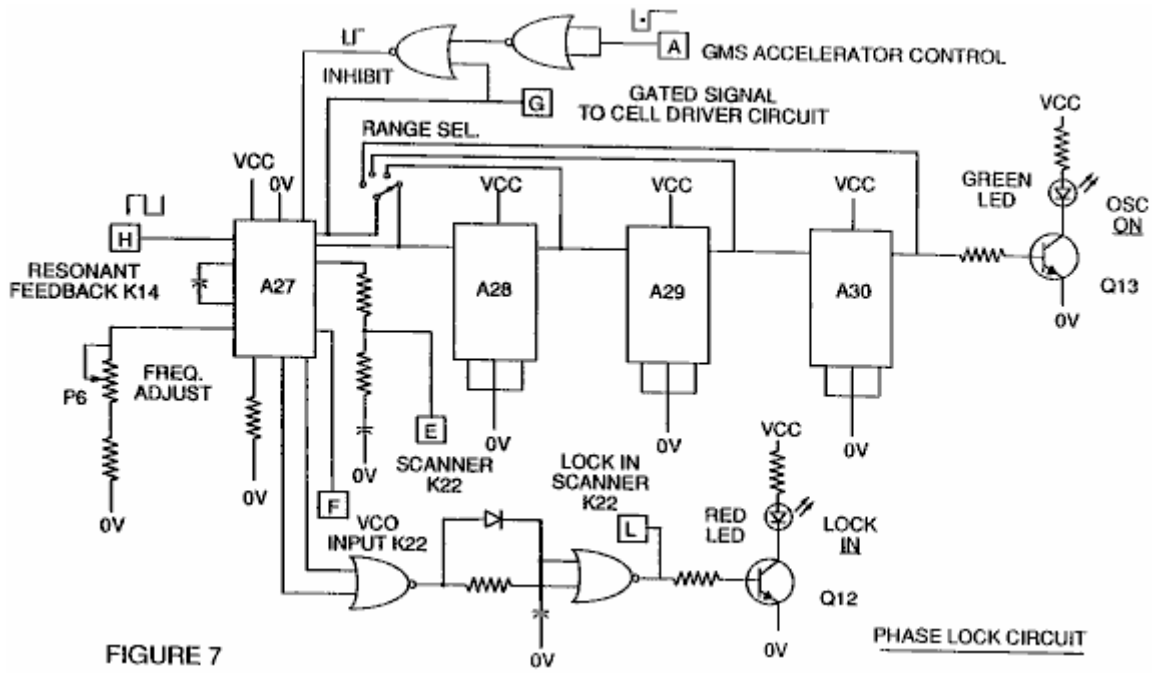

Fig.7 is a phase lock circuit.

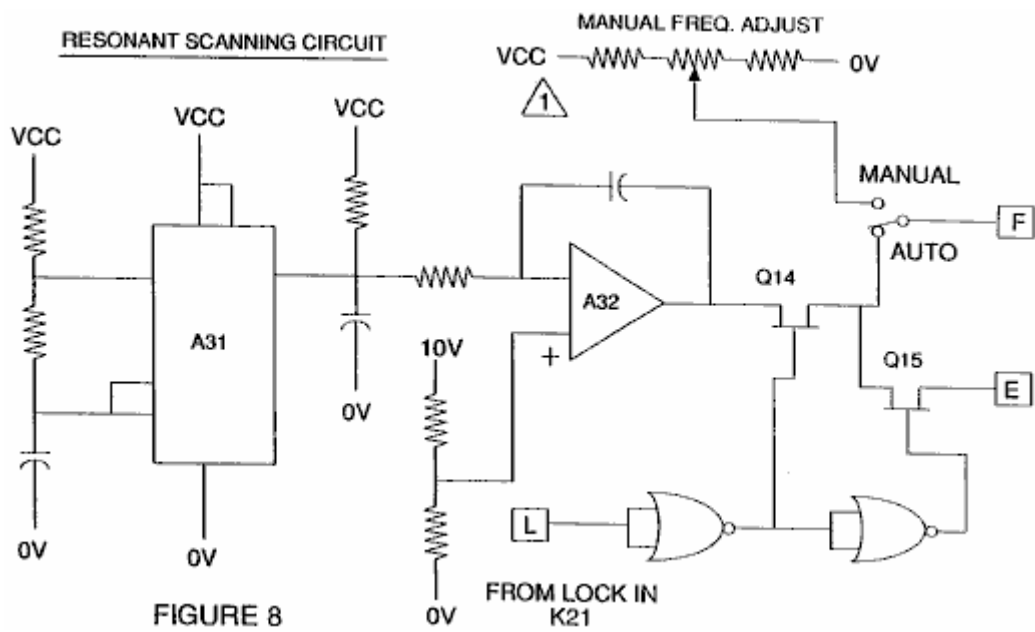

Fig.8 is a resonant scanning circuit

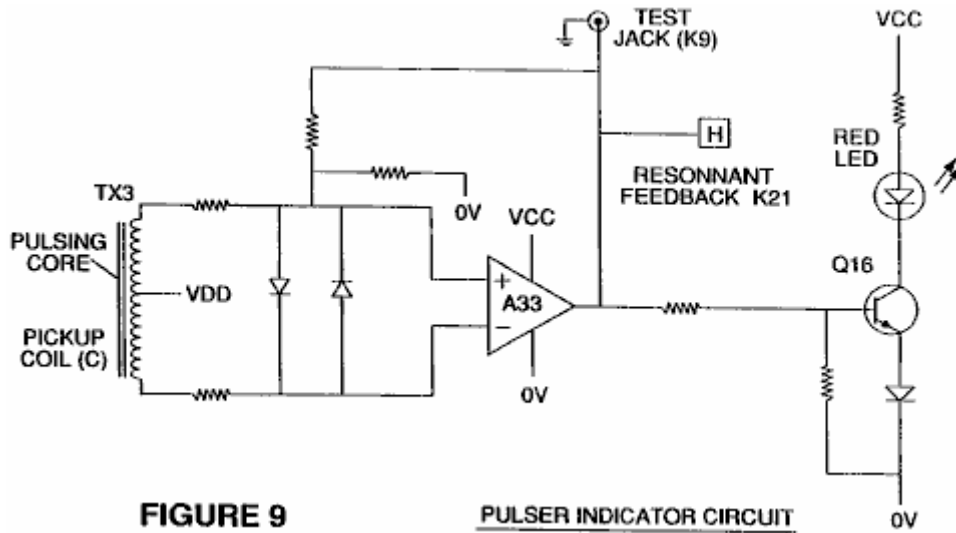

FIGURE 9

PULSER INDICATOR CIRCUIT

Fig.9 is the pulse indicator circuit.

These four circuits control the pulses transmitted to the resonant-cavity / Water Fuel Cell capacitor.

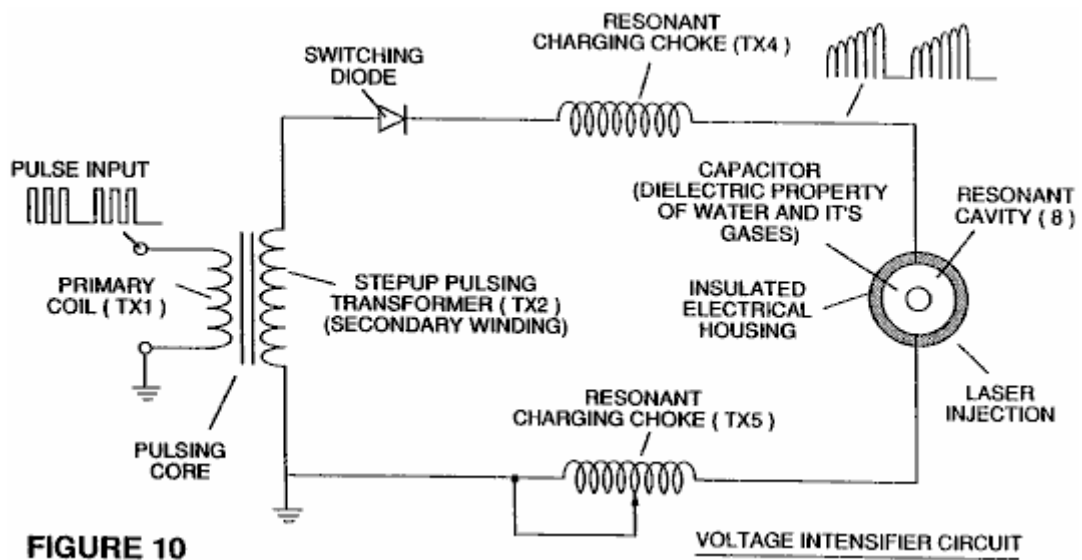

FIGURE 10

VOLTAGE INTENSIFIER CIRCUIT

Fig.10 shows the pulsing core and the voltage intensifier circuit which forms the interface between the control circuit and the resonant cavity.

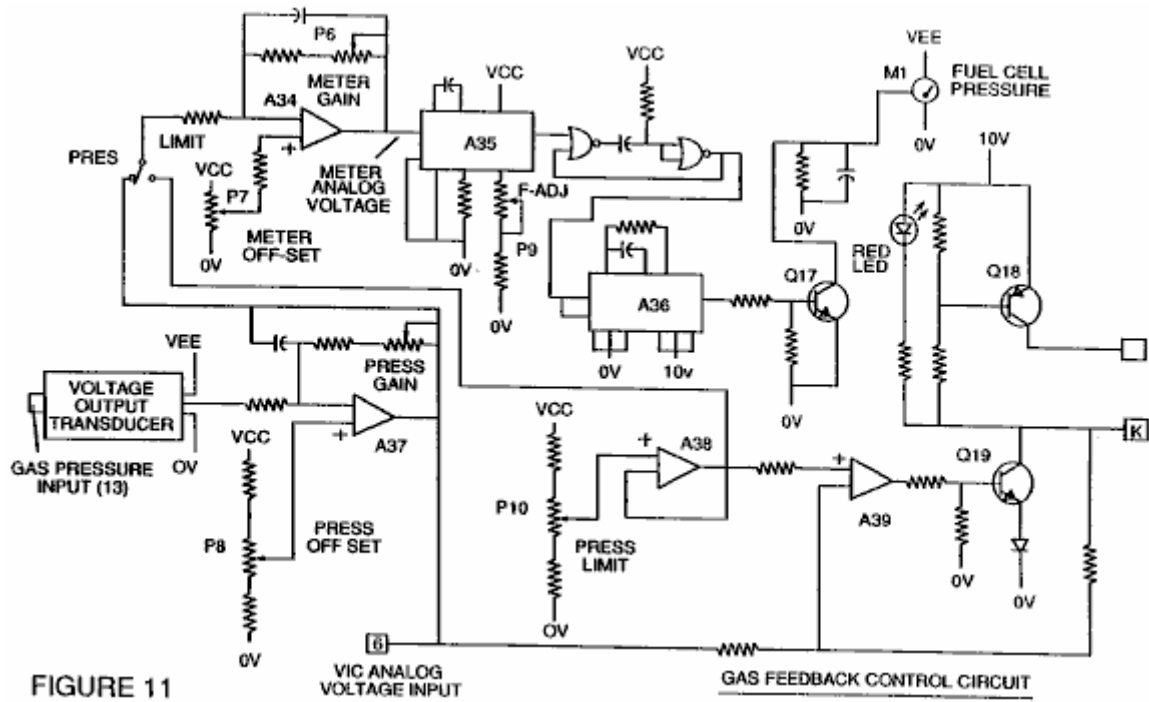

FIGURE 11

Fig.11 is a gas feedback control circuit

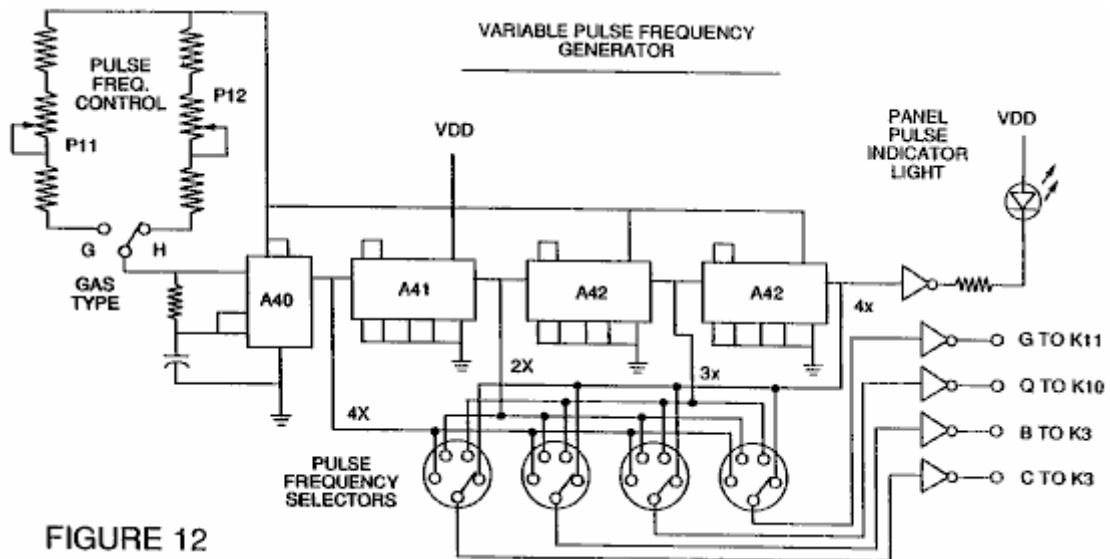
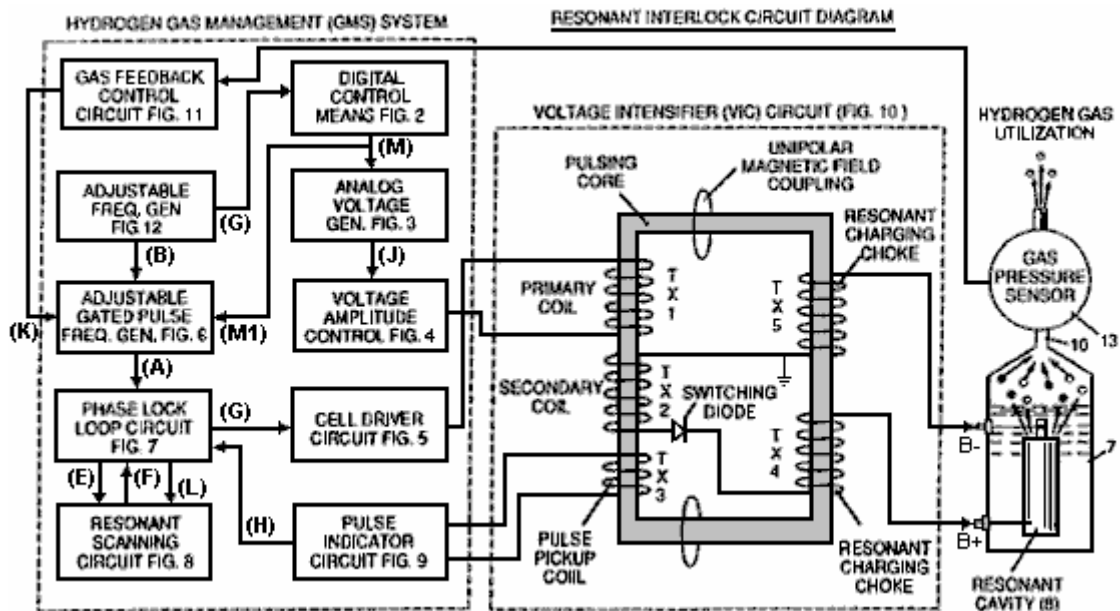

FIGURE 12

Fig.12 is an adjustable frequency generator circuit.



The circuits are interconnected as shown in **Fig.1** and to the pulsing core voltage intensifier circuit of **Fig.10**, which, among other things, isolates the water capacitor electrically so that it becomes an electrically isolated cavity for the processing of water in accordance with its dielectric resonance properties. By reason of this isolation, power consumption in the control and driving circuits is minimised when resonance occurs, and current demand is minimised as voltage is maximised in the gas production mode of the water capacitor / Fuel Cell.

The reference letters “A” through “M” and “M1” show, with respect to each separate circuit shown, the point at which a connection in that circuit is made to another of the circuits shown.

In the invention, the water capacitor is subjected to a duty pulse which builds up in the resonant charging choke coil and then collapses. This occurrence allows a unipolar pulse to be applied to the Fuel Cell capacitor. When a resonant condition of the circuit is locked-in by the circuit, current leakage is held to a minimum as the voltage which creates the dielectric field tends to infinity. Thus, when high voltage is detected upon resonance, the phase-lock-loop circuit, which controls the cell driver circuit, maintains the resonance at the detected (or sensed) frequency.

The resonance of the water capacitor cell is affected by the volume of water in the cell. The resonance of any given volume of water contained in the water capacitor cell is also affected by “contaminants” in the water which act as a damper. For example, with a potential difference of 2,000 to 5,000 volts applied to the cell, a current spike or surge may be caused by inconsistencies in the water characteristics which cause an out-of-resonance condition which is remedied instantaneously by the control circuits.

In the invention, the adjustable frequency generator, shown in **Fig.12**, tunes in to the resonant condition of the circuit which includes the water cell and the water inside it. The generator has a frequency capability of 0 to 10 KHz and tunes into resonance typically at a frequency of 5 KHz in a typical 3-inch long water capacitor formed from a 0.5 inch rod inside a 0.75 inch inside-diameter cylinder. At start up, in this example, current draw through the water cell will measure about 25 milliamps; however, when the circuit finds a tuned resonant condition, the current drops down to a 1 to 2 milliamp leakage condition.

The voltage to the capacitor water cell increases according to the turns of the winding and the size of the coils, as in a typical transformer circuit. For example, if 12 volts is sent to the primary coil of the pulsing core and the secondary coil resonant charging choke ratio is 30 to 1, then 360 volts is sent to the capacitor water cell. The number of turns is a design variable which controls the voltage of the unipolar pulses sent to the capacitor.

The high-speed switching diode, shown in **Fig.10**, prevents charge leaking from the charged water in the water capacitor cavity, and the water capacitor as an overall capacitor circuit element, i.e. the pulse and charge status of the water/capacitor never pass through an arbitrary ground. the pulse to the water capacitor is always unipolar. The water capacitor is electrically isolated from the control, input and driver circuits by the electromagnetic coupling through the core. The switching diode in the Voltage Intensifier Circuit (**Fig.10**) performs several functions in the pulsing. The diode is an electronic switch which determines the generation and collapse of an electromagnetic field to permit the resonant charging choke(s) to double the applied frequency and it also allows the pulse to be sent to the resonant cavity without discharging the “capacitor” therein. The diode is, of course,

selected in accordance with the maximum voltage encountered in the pulsing circuit. A 600 PIV ("Peak Inverse Volts") fast switching diode, such as an NVR 1550, has been found to be useful in this circuit.

The Voltage Intensifier Circuit of **Fig.10** also includes a ferromagnetic or ceramic ferromagnetic pulsing core capable of producing electromagnetic flux lines in response to an electrical pulse input. The flux lines affect both the secondary coil and the resonant charging choke windings equally. Preferably, the core is of a closed loop construction. The effect of the core is to isolate the water capacitor and to prevent the pulsing signal from going below an arbitrary ground and to maintain the charge of the already charged water and water capacitor.

In the pulsing core, the coils are preferably wound in the same direction to maximise the additive effect of the electromagnetic field in them. The magnetic field of the pulsing core is synchronised with the pulse input to the primary coil. The potential from the secondary coil is introduced to the resonant charging choke(s) series circuit elements which are subjected to the same synchronous applied electromagnetic field, simultaneously with the primary pulse.

When resonance occurs, control of the gas output is achieved by varying the time of duty gate cycle. The transformer core is a pulse frequency doubler. In a figurative explanation of the workings of the fuel gas generator water capacitor cell, when a water molecule is "hit" by a pulse, electron time-share is effected and the molecule is charged. When the time of the duty cycle is changed, the number of pulses that "hit" the molecules in the fuel cell is modified correspondingly. More "hits" result in a greater rate of molecular disassociation.

With reference to the overall circuit of **Fig.1**, **Fig.3** receives a digital input signal, and **Fig.4** shows the control circuit which applies 0 to 12 volts across the primary coil of the pulsing core. Depending on design parameters of primary coil voltage and other factors relevant to core design, the secondary coil of the pulsing core can be set up for a predetermined maximum, such as 2,000 volts.

The cell driver circuit shown in **Fig.5**, allows a gated pulse to be varied in direct relation to voltage amplitude. As noted above, the circuit of **Fig.6** produces a gate pulse frequency. The gate pulse is superimposed on the resonant frequency pulse, to create a duty cycle that determines the number of discrete pulses sent to the primary coil. For example, assuming a resonant pulse of 5 KHz, a 0.5 KHz gating pulse with a 50% duty cycle, will allow 2,500 discrete pulses to be sent to the primary coil, followed by an equal time interval in which no pulses are passed through. The relationship of resonant pulse to the gate pulse is determined by conventional signal addition/subtraction techniques.

The phase lock loop circuit shown in **Fig.7** allows the pulse frequency to be maintained at a predetermined resonant condition sensed by the circuit. Together, the circuits of **Fig.7** and **Fig.8**, determine an output signal to the pulsing core until the peak voltage signal sensed at resonance is achieved.

A resonant condition occurs when the pulse frequency and the voltage input attenuates the covalent bonding forces of the hydrogen and oxygen atoms of the water molecule. When this occurs, current leakage through the water capacitor is minimised. The tendency of voltage to maximise at resonance, increases the force of the electric potential applied to the water molecules, which ultimately disassociate into atoms.

Because resonances of different waters, water volumes and capacitor cells vary, the resonant scanning circuit of **Fig.8** scans frequency from high to low and back to high, until a signal lock is achieved. The ferromagnetic core of the voltage intensifier circuit transformer, suppresses electron surge in an out-of-resonance condition of the fuel cell. In an example, the circuit scans at frequencies from 0 Hz to 10 KHz and back to 0 Hz. In water having contaminants in the range of 1 part per million to 20 parts per million, a 20% variation in resonant frequency is encountered. depending on water flow rate into the fuel cell, the normal variation range is about 8% to 10%. For example, iron in well water affects the status of molecular disassociation. Also, at a resonant condition, harmonic effects occur. In a typical operation of the cell with a representative water capacitor described below, at a frequency of about 5 KHz, with unipolar pulses from 0 to 650 volts, at a sensed resonant condition in the resonant cavity, on average, the conversion into gas occurs at a rate of about 5 US gallons (19 litres) of water per hour. To increase the rate, multiple resonant cavities can be used and/or the surfaces of the water capacitor can be increased, however, the water capacitor cell is preferably small in size. A typical water capacitor may be formed from a 0.5 inch diameter stainless steel rod and a 0.75 inch inside-diameter cylinder which extends over the rod for a length of 3 inches.

The shape and size of the resonant cavity may vary. Larger resonant cavities and higher rates of consumption of water in the conversion process require higher frequencies up to 50 KHz and above. The pulsing rate, to sustain such high rates of conversion, must be increased correspondingly.

From the above description of the preferred embodiment, other variations and modifications of the system disclosed will be evident to those skilled in the art.

CLAIMS

1. A control circuit for a resonant cavity water capacitor cell utilised for the production of a hydrogen- containing fuel gas, including an isolation transformer with a ferromagnetic core, and having one side of a secondary coil connected in series with a high-speed switching diode to one plate of the water capacitor of the resonant cavity, and the other side of the secondary coil connected to the other plate of the water capacitor, to form a closed-loop electronic circuit utilising the dielectric properties of water as part of the electronic circuit, and a primary coil connected to a pulse generator.
2. The circuit of Claim 1. in which the secondary coil includes segments which form a resonant charging choke circuit in series with the water capacitor.
3. The circuit of Claim 1. in which the pulse generator includes an adjustable first frequency generator and a second gated pulse frequency generator which controls the number of pulses produced by the first frequency generator, sent to the primary coil during a period determined by the gate frequency of the second pulse generator.
4. The circuit of Claim 1. further including a means for sensing the occurrence of a resonant condition in the water capacitor of the resonant cavity.
5. The circuit of Claim 4. in which the means for sensing is a pickup coil on the ferromagnetic core of the transformer.
6. The circuit of Claim 4. or Claim 5. in which the sensing means is interconnected to a scanning circuit and a phase-lock-loop circuit, by which the pulsing frequency sent to the primary coil of the transformer is maintained at a sensed frequency corresponding to a resonant condition in the water capacitor.
7. The circuit of Claim 1. including means for adjusting the amplitude of a pulsing cycle sent to the primary coil.
8. The circuit of Claim 6. including further means for maintaining the frequency of the pulsing cycle at a constant frequency regardless of pulse amplitude.
9. the circuit of Claim 3. in which the gated pulse frequency generator is connected to a sensor which monitors the rate of gas production from the cell and controls the number of pulses sent to the cell in a gated frequency, corresponding to the rate of gas production.
10. The circuit of Claim 7. or Claim 8. or Claim 9. further including a gas-pressure sensor in an enclosed water capacitor resonant cavity which also includes a gas outlet, where the gas-pressure sensor is connected to the circuit to determine the rate of gas production with respect to ambient gas pressure in the water capacitor enclosure.
11. The methods and apparatus as substantially described herein.

STEPHEN MEYER

Patent application US 2005/0246059 3rd November 2005 Inventor: Stephen F. Meyer

MLS-HYDROXYL FILLING STATION

This is a patent application from Stephen Meyer, brother of the late Stan Meyer. While this application mentions filling stations, it is clear that the design is aimed at use in vehicles with internal combustion engines. I believe that the impedance-matching interface between the alternator and the cell electrodes is particularly important. The water-splitter cell uses sets of three pipes in a concentric array which results in small gaps between the innermost, middle and outer pipe. Stephen refers to these three electrode pipes as a "wave-guide", so please bear that in mind when reading this patent application. Stephen uses the word "hydroxyl" to refer to the mixture of hydrogen and oxygen gases produced by electrolysis of water. Other people use the word "hydroxy" to describe this mixture, so they should be considered interchangeable.

The operation of this system as described here, calls for the generating power to be removed when the gas pressure in the generating chambers reaches 5 psi. The gas is then pumped into a pressure chamber where the pressure ranges from 40 psi to 80 psi, at which point the compressor is powered down and the excess gas vented to some external storage or using device. It is not until this is completed that the power is applied again to the generating chambers. May I remark that, in my opinion, there is no need to remove the power from at generating chambers at any time when this system is in operation, since all that that does is to lower the generating capacity, unless of course, the production rate is so high that it exceeds the level of demand.

ABSTRACT

The usefulness of this system, it's configuration, design and operation, are the keystone of a new type of automation: the production of hydroxyl gases from renewable sources.

BACKGROUND OF THE INVENTION

Fuel Cell and auto industries have been looking for methods and apparatus that can supply a source of hydrogen and oxygen for its new hybrid industry. This invention is such a device.

SUMMARY OF THE INVENTION

The invention is a computerised, automatic, on-site/mobile hydroxyl gas producing filling station which allows the products being produced to be used, either by the hydrogen fuel cells installed in automobiles, trucks, buses, boats and land-based generating applications, or in any internal combustion engine.

BRIEF DESCRIPTION OF THE DRAWINGS

Fig.1 shows the configuration of the components which go to make up the MLS-hydroxyl Filling Station.

Fig.2 shows the software display which the operator uses to monitor and control the production of hydroxy gases and heat.

Fig.3 shows the methods, configuration, and apparatus used in the hydroxyl producing cell system **120**.

Fig.4 shows the electronic impedance-matching circuits **102**, connected between the dual three-phase synchronised generators (**110A** and **110B** in **Fig.3**) and each of the electrodes or "waveguide" arrays **132** in cell **120** of **Fig.3**. Note that only generator **A** is depicted in **Fig.4** as being connected to arrays **A**, **B** and **C** using PC cards **1 to 3**. generator **B** is connected to arrays **D**, **E** and **F** using cards **4 to 6**.

Fig.5 Shows the signals emitted by each of the impedance-matching circuits (**102** in **Fig.4** mounted on cards **1 to 6**) which are applied to each of the cylinder arrays (**132** in **Fig.3**) installed in hydroxyl cell **120**. These sets of signals with their offset phase relationship, frequencies and amplitudes, are the driving forces producing the hydroxy gases in cell **120** of **Fig.3**.

Fig.6 shows the high-frequency ringing signal which is produced between points **T1** and **T2** in the impedance-matching circuit **102** in **Fig.4**. It is this ringing which enhances the production of the hydroxyl gas in cell **120** of **Fig.3**.

DETAILED DESCRIPTION OF THE DRAWINGS

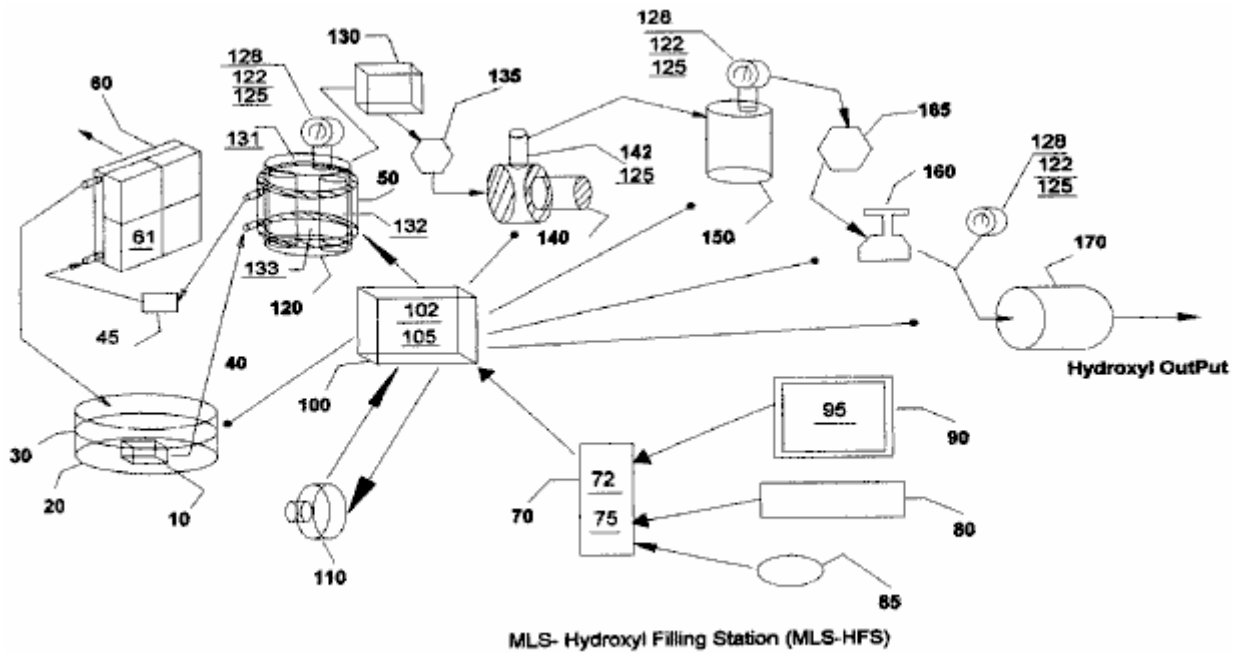

Fig 1

The heat-removing section in **Fig.1** consists of a liquid bath **30** and its container **20**, a liquid circulating pump **10**, conveying-conduits **40**, cooling chamber **50** attached to hydroxyl generating cell **120**, filter **45**, radiator **60** and cooling fans **61** attached to it.

The automatic-control section in **Fig.1** consists of a computer **70**, software program **75**, video monitor **90** and it's graphic operator display **95** (**Fig.2**), pointer **85**, keyboard **80**, interface card **72**, and Input/Output controller **100** with it's driver electronics cards **102** and **105**.

Dual three-phase power sources **110** and impedance-matching circuits **102**, provide the power needed to drive the hydroxyl cell **120**.

The remaining apparatus is used to convey the gases from cells **120**, through liquid trap **130**, through gas flow restriction valve **135**, elevate its gas pressures through compressor **140**, transfer them to storage tank **150**, then deliver the gases through safety cut off **165**, regulators **160** and through flash-back arrestor **170** for external delivery.

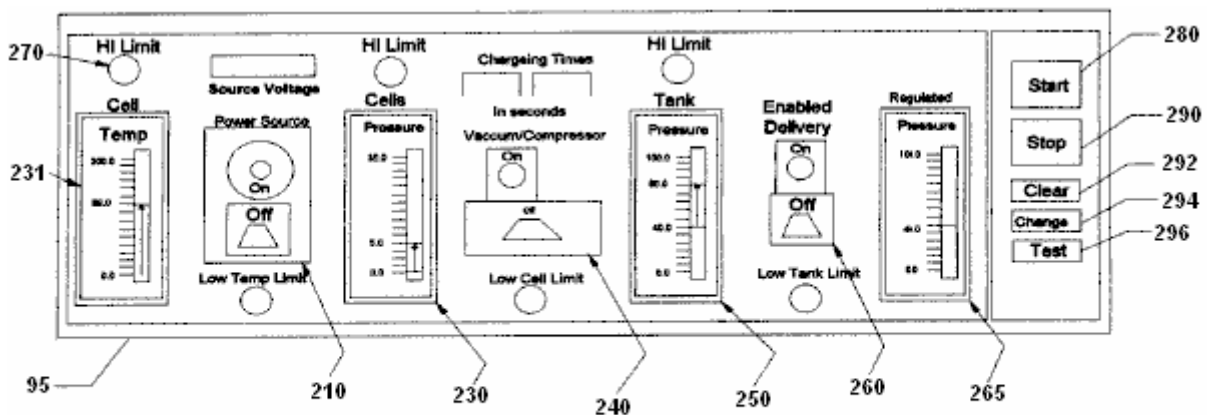

MLS-Hydroxyl Filling Station (MLS-HFS) Graph Display and Operator Control

Fig-2

Fig.2 shows the layout and functions of the operator control display **95** of program **75** in **Fig.1**. It consists of cell temperature indicator **230**, vacuum controller **240**, high-pressure tank indicator **250**, delivery controller **260**, delivery regulated-pressure indicator **265** and related alarm/status indicators **270**. Also, software control buttons

are provided to start 280, stop 290, clear data 292, change setting 294 and the testing of equipment and their sequences 296.

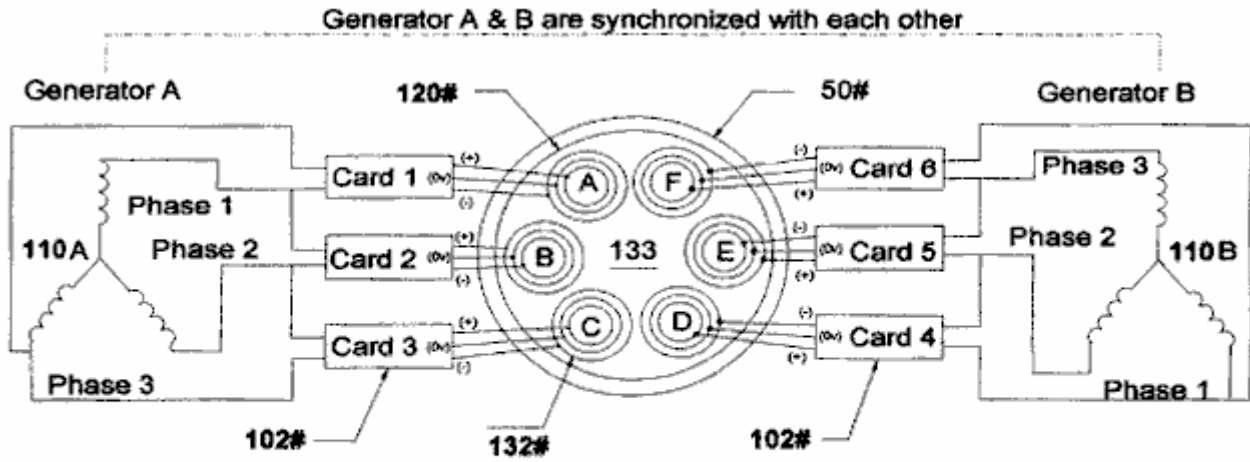

Configuration of Hydroxyl gas producing appartuses
Fig-3

Fig.3 shows the configuration of our proprietary hydroxyl-producing apparatus **120** consisting of dual three-phase power source **110**, impedance matching electronic circuits **102** and gas converter devices **132** submerged in a bath of water **133** in cell **120**. The drawing also shows the water jacket **50** surrounding the cell **120** that helps lower its temperature and allows more production of the hydroxyl gases at higher voltage signals as shown in **Fig.5**.

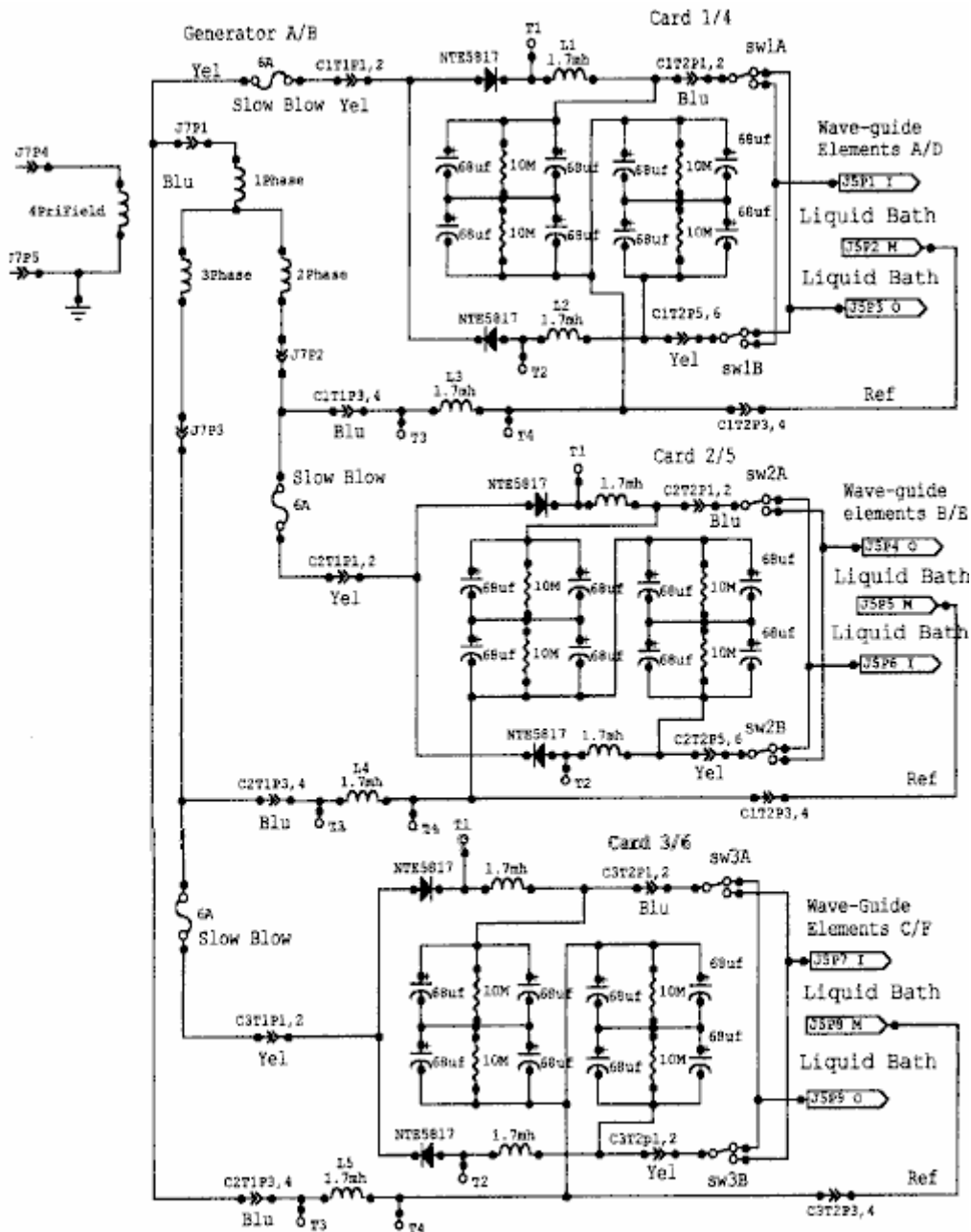

Impedance matching circuits 102
Fig-4

Fig.4 shows the electrical circuits **102**, used to drive the gas converting arrays (**132** in **Fig.3**) submerged in a bath of water **133** in cell **120**. **Fig.4** shows three identical circuits connected to each of the three-phase signals from one half of the dual three-phase generator **110A** in **Fig.3**. The circuits **102**, convert the AC signal from each phase of **110** into a modulated signal as depicted by **Fig.5**. These signals are then coupled to the triple array elements **132**, (Inside, Middle and Outside) by alternating the connection between the Inside and Outside elements of the arrays (**132** in **Fig.3**).

Signals Traveling Wave Guide

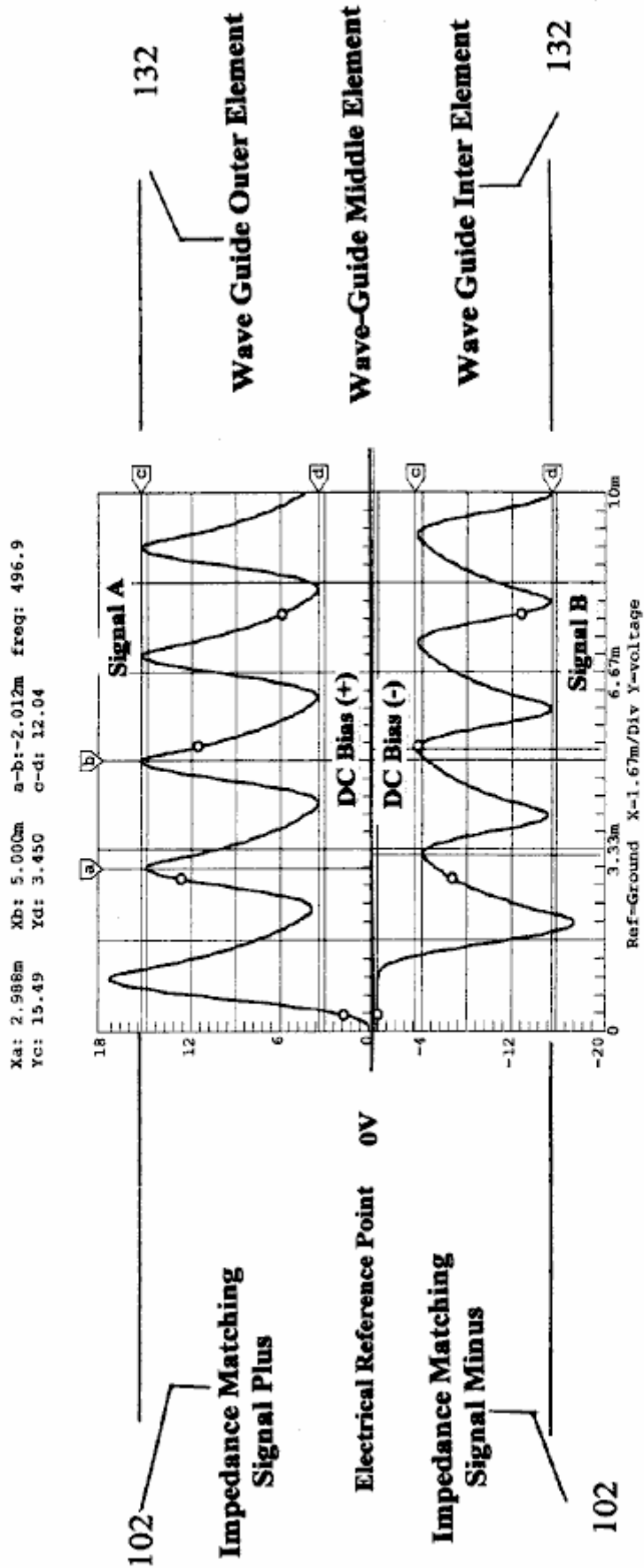

FIG-5

Fig.5 shows the composite signals applied to each of the arrays (132 in Fig.3) submerged in the water bath 133 in cell 120, and indicates the differential voltages used in the hydroxyl producing process. Note that the Middle wave-guide element is used as the electrical reference point for both the Outside and Inside elements of array 132. It is this composite signal applied to the surface of the stainless steel elements in array 132 submerged in water bath 133, heat allows the ions from the elements in array 132 to cross its water surface barriers 133 and contribute to the hy-droxyl production. Note the DC bias voltage +,- on either side of the centre electrical

reference point 0V. It is this bias voltage being modulated by multi-polarity differential signals from 102, that contributes to the wave-guide action of arrays 132. Also, the frequency of the waveform shown in Fig.5 is adjusted to match the electrical wavelength of the arrays 132 of Fig.3 and the impedance of water bath 133.

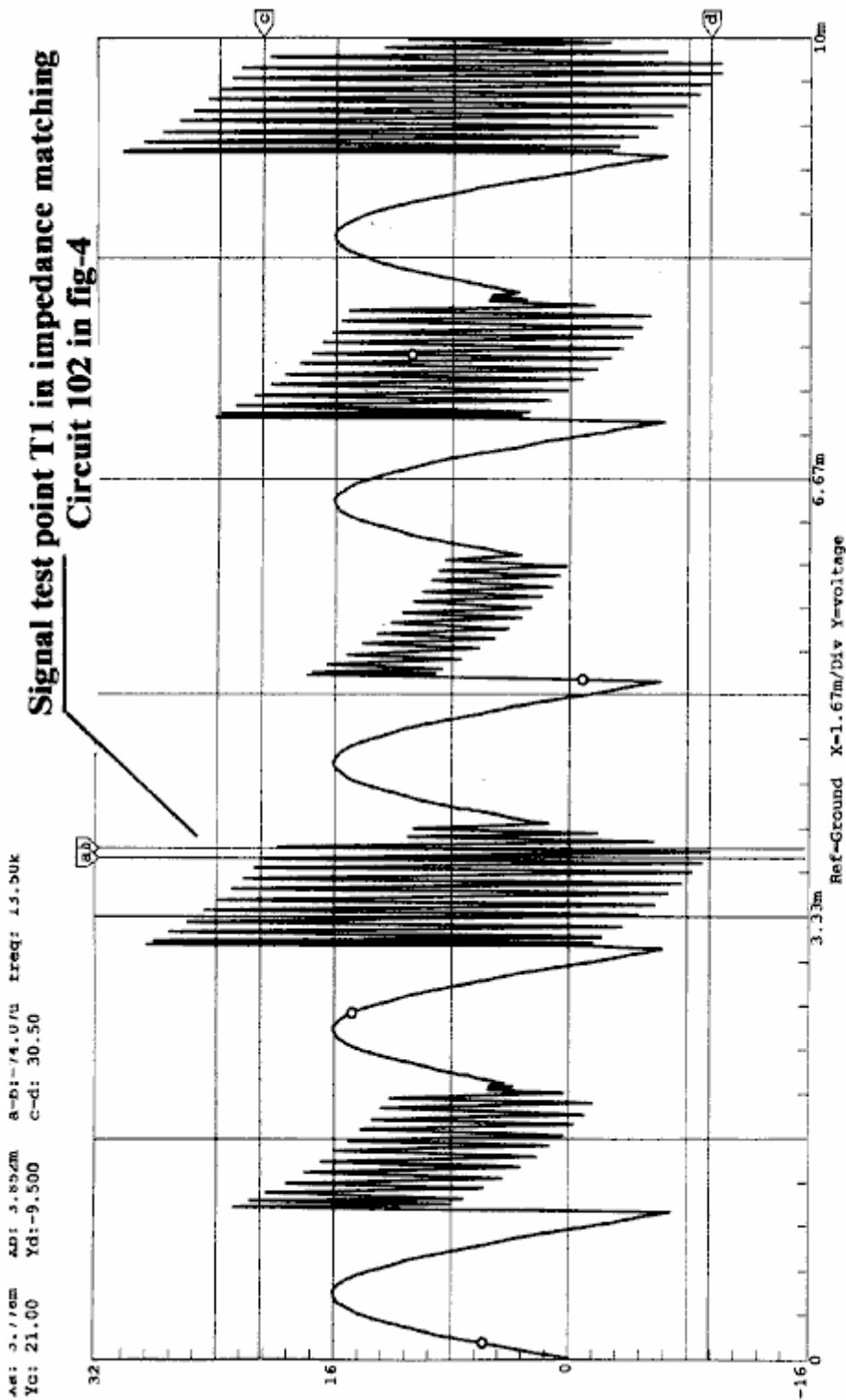

FIG-6

Fig.6 shows the high-frequency ringing signals which contribute to the operation of the hydroxyl production. just as a tuning fork rings when struck by a hammer, so do the wave-guide elements in array 132 immersed in the hydroxyl-generating liquid 133 when struck by the electrical signals shown in Fig.5 and Fig.6, coming from the impedance-matching circuits 102 shown in Fig.4.

Brief Description of Sequences

This invention is a computerised Hydroxyl Gas producing filling station "MLS-HFS" designed to provide automatic control of its on-site gas production and delivery.

The MLS-HFS shown in **Fig.1**, is a hydroxyl gas and heat generating system which uses a renewable source of liquid supply **30** such as water. It uses a computer control program **75** with display interface **95**, for the monitoring, adjusting and controlling of the electronic and hardware apparatus and process logic. The electronic circuits **102** mounted in driver **100**, control the production of the gases and heating while circuit **105** controls the process and routing of the hydroxyl gas.

The system consists of a low-pressure hydrolyser cell **120** in **Fig.1**, a liquid trap **130**, an adjustable flow-restriction valve **135**, high-pressure vacuum pump **140**, and check valve **142** installed in **140**. It also contains a high-pressure storage tank **150**, an alarm/low-pressure cut-off valve **165**, gas regulator **160**, flashback arrestor **170**, over-pressure safety release valves **125**, pressure gauges **128**, analogue pressure-sending units **122** installed on cell **120**, and tank **150** at the regulating side of regulator **160**. Also, **125** is installed on Compressor **140** high-pressure output. The computer controller **70**, monitor **90**, keyboard **80**, interface I/O card **72** and software position pointer **85**, are used to control the production process, using electronic driver **100** through it's PC boards **105** and their attached control devices. The power to the cell-driving circuits **102**, installed in driver **100**, is supplied from a dual three-phase isolated power source **110**. The amplitude, signal phases and frequency from this power source is controlled by signal adjustments coming from the computer **70**.

Detailed Description

Sequence of Operation

The system shown in **Fig.1** is monitored and controlled by the software program **75**, computer **70**, monitor **90**, keyboard **80**, pointer **85**, and display interface **95** in **Fig.2**.

The software program has five main functions, namely: to purge the system of ambient air, check and test for any equipment malfunctions, prepare the system for production, monitor and control the current activities of the production process, and the safety shutdown of the system if alarms are detected.

During the initial installation, and again after any repairs, the total system is purged using the vacuum pump **140**, using manual procedures to ensure that all ambient air has been removed from the system. Before the system is put into service, the operator can test the operation of the system by using the graphic display. The main functions of the testing is to ensure that the temperature electronics **131** attached to the hydroxyl cells **120**, transferring compressor **140** and analogue pressure sensors **122** mounted on cells **120**, high-pressure tank **150** and the discharge side of regulator **160** used for control and monitoring, are working properly. the operator can then activate the Run Sequence of the program **75** via the start software button **280** in **Fig.2** on graphic display **95**.

During the initial startup phase of the system, the computer program will configure the system for the purge sequence. this sequence allows the vacuum pump **140** to draw down the hydroxyl cells **120** liquid trap **130** coupled to flow-restriction valve **135**, to remove all ambient air from them. Once the program has done this and detected no leaks in the system, it then prepares the system for gas production by switching the gas flow from cells **120** to high-pressure tank **150** and on to the output flashback protector **170**.

The program starts it's production sequence by turning on the cooling system pump **10** which is submerged in the liquid bath **30**, contained in vessel **20**. The cooling liquid is pumped through the cooling jacket **50** which is attached to the outside of cells **120**, through filter **45** and then through an air-cooled radiator **60**. Fans attached to the radiator are turned on for cooling.

Next, the computer turns on the dual three-phase power source **110**, which supplies operating power to the frequency, phase-shifting, signal amplitude and impedance-matching circuits coupled to the hydroxyl generating cells.

The result of this is just like the operation of a radio transmitter matching it's signal to the air via the antenna impedance. **Fig.3** shows the relationship of this configuration to arrays **132**, water bath **133** and Signals (**Fig.5** and **Fig.6**).

While the power source **110** is operating, the computer **70** is monitoring the pressure **122** and temperature **131** of hydroxyl cells **120**. When the cell pressure reaches a typical level of **5** pounds per square inch, the power source is turned off and compressor **140** is turned on the pump the gas into pressure tank **150**. When the pressure in the hydroxyl cells **120** is drawn down to near zero, the compressor is turned off and the power to the gas generating cells is turned back on again, to repeat the cycle.

The production cycle is repeated until tank **150** reaches a pressure of, typically, 80 psi, at which time the computer enables the output pressure regulator **160** which is typically set to operate at 40 psi, for the delivery of the hydroxyl gas to some external storage system or device. During this operation, the computer program handles all switching and displays the current status and any alerts or warning messages for the operator on the graphical display **95**.

Impedance-Matching Circuit 102:

The impedance-matching circuits **102** in **Fig.4**, convert the sinewave signals coming from the three-phase power source (**110** in **Fig.3**) into multi-polarity differential signals (**Fig.5**) which are applied to the triple wave-guide cluster arrays **132 A, 132B, 132C, 132D, 132E** and **132F** installed in cell **120**.

It is this converted signal, along with the phase relationship of the power source **110** and the triple wave-guide elements in cluster **132** submerged in water bath **133**, which produce the hydroxyl gases. It is important to note that not only is the gas produced between the elements in the array, but also between each array installed in the cell - see the phase relationship of array **A-B-C** shown in **Fig.3**. Also note that the array elements themselves are supplying many of the ions needed for the production of the gases.

Sequence of Hydroxyl Gas Generation:

Once the hydroxyl-generating cell **120** has been purged of ambient air and the production routing completed (**Fig.1**), the dual three-phase power source **110** is activated, supplying frequency, amplitude and phase signals to the impedance-matching circuitry **102**. The converted signals from **102** are then applied to cell array **132** for processing. It is the combination of the impedance-matching circuits signal transformations (as shown in **Fig.5** and **Fig.6**), the cell configuration and materials used in arrays **132**, and the rotational phase relationship between arrays **AD, BE** and **CF** and the submersion of these arrays in a bath of water **133**, that allows this system to produce large amounts of hydroxyl gases. The computer program **75** and its graphic display **95**, is used by the operator to adjust the rate of gas production and set the upper limit to which the low-pressure cell **120** will charge.

After the cell **120** has reached its upper pressure cut-off limit (typically 5 psi), the power source **110** is turned off, enabling the compressor **140** to start its draw-down and transfer of the gases to the high-pressure tank **150**. When the pressure in the cell **120** reaches a low-level limit (near zero psi), **140** stops its charging cycle of **150**. Check valve **142** which is installed in **140**, prevents any back flow of gases to **120** from high-pressure tank **150**. The power source **110** is then turned back on to repeat the cycle. These charging cycles continue until the high-pressure tank **150** reaches its upper pressure limit (typically 80 psi), at which point the hydroxyl production is stopped. As the gases in the high-pressure tank are being used or transferred to some external storage system, the pressure in **150** is monitored at the output of pressure-regulator **160**, until the low-pressure limit for this tank is reached (typically 40 psi). When this pressure level is reached, the hydroxyl gas production is started again.

During the operation of cell **120**, its temperature is monitored to ensure that it does not exceed the "out of limits" conditions set by control **231** and monitored via the graphics display **95**. If the temperature exceed the limit set, then the gas production is stopped and the computer program alerts the operator, indicating the problem. The cooling system **30** which uses water jacket **50** surrounding cell **120**, helps to reduce the temperature and allows higher rates of gas production.

After extended running times, the water in cell **120** is replenished from bath **30** and filtered by **45**, to help control the operating impedance of the cell.

CLAIMS

1. The MLS-HFS information in this specification is the embodiment of the claims.
2. The system according to Claim 1 further enhances the production of hydroxyls based on the configuration of the hydroxyl gas-producing apparatuses of **Fig.3**.
3. The system according to Claim 1 further enhances the production of hydroxyls based on the configuration of the impedance-matching circuits of **Fig.4**.
4. The system according to Claim 1 further enhances the production of hydroxyls based on the application of the electrical signals shown in **Fig.5** applied to signal travelling wave-guides **132** submerged in a bath of water **133** installed in cell **120** and configured as depicted in **Fig.3**.

5. The system according to Claim 1 further enhances the production of hydroxyls based on the resonating action of the electrical signals depicted in **Fig.6**.
6. The system according to Claim 1 further enhances the production of hydroxyls based on the software program's ability to control the production of hydroxyl gases; controlling it's process limits, controlling it's storage and controlling it's delivery via operator controller **Fig.2**.
7. The software program **75** according to Claim 6, further enhances the safety of the production of hydroxyls based on the monitoring of high and low limits and either alerting the operator of the conditions and/or stopping the production on device failures via operator controller **Fig.2**.
8. The software according to Claim 6 further enhances the safety of the hydroxyls based on its ability to purge the system of ambient air before starting the production of hydroxyl gases.

Dr HENRY PUHARICH



Dr Andrija Puharich (who later changed his name to Henry Puharich) reportedly drove his motor home for hundreds of thousands of miles around North America in the 1970s using only water as fuel. At a mountain pass in Mexico, he collected snow for water. Here is an article which he wrote:

Cutting The Gordian Knot of the Great Energy Bind by Andrija Puharich

Introduction

It is hardly necessary to weigh the value of the World Energy bank account for any sophisticated person, these days. It is grim. The oil reserves will dwindle away in a score of years or so, and the coal reserves will be gone in some twelve score years. This is not to say that the outlook is hopeless. There is an abundance of alternative energy sources, but the economics of development and exploitation present an enormous short-term strain on the world political and banking resources.

Visionary scientists tell us that the ideal fuel in the future will be as cheap as water, that it will be non-toxic both in its short-term, and in its long-term, effects, that it will be renewable in that it can be used over and over again, that it will be safe to handle, and present minimal storage and transportation problems and costs. And finally that it will be universally available anywhere on earth. What is this magical fuel, and why is it not being used? The fuel is water. It can be used in its fresh water form. It can be used in its salt water form. It can be used in its brackish form. It can be used in its snow and ice form. When such water is decomposed by electrolytic fission into hydrogen and oxygen gases, it becomes a high energy fuel with three times the energy output which is available from an equivalent weight of high grade gasoline.

Then why is water not being used as a fuel? The answer is simple - it costs too much with existing technology to convert water into hydrogen and oxygen gases. The basic cycle of using water for fuel is described in the following two equations, familiar to every high school student of Chemistry:

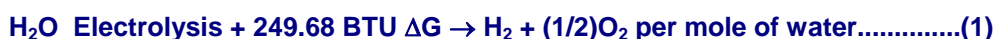

(1 mole = 18 gm). This means that it requires 249.688 BTU of energy (from electricity) to break water by electrolysis into the gases hydrogen and oxygen.



This means that 302.375 BTU of energy (heat or electricity) will be released when the gases, hydrogen and oxygen, combine. The end product (the exhaust) from this reaction is water. Note that more energy (under ideal conditions) is released from combining the gases than is used to free them from water. It is known that under ideal conditions it is possible to get some 20% more energy out of reaction (2) above, than it takes to produce the gases of reaction (1) above. Therefore, if reaction (1) could be carried out at 100% efficiency, the release of energy from reaction (2) in an optimally efficient engine (such as a low temperature fuel cell), there would be a net energy profit which would make the use of water as a fuel an economically feasible source of energy .

The cost of producing hydrogen is directly related to the cost of producing electricity. Hydrogen as produced today is generally a by-product of off-peak-hour electrical production in either nuclear or hydroelectric plants. The electricity thus produced is the cheapest way of making hydrogen. We can compare the cost of production of electricity and the cost of producing hydrogen. The following table is adapted from Penner whose data source is based on Federal Power Commission, and American Gas Association Figures of 1970 and on a 1973 price evaluation (just before the OPEC oil price escalation.)

Table 1: Relative Prices in Dollars per 106 BTU

Cost Component	Electricity	Electrolytically-Produced H
Production	2.67 (b)	2.95 to 3.23 (b)
Transmission	0.61	0.52 (c)
Distribution	1.61	0.34
Total Cost	\$4.89	\$3.81 to \$4.09

If we compare only the unit cost of production of electricity vs Hydrogen from the above table:

106 BTU H₂ / 106 BTU EI = \$3.23 / \$2.67, or 20.9% higher cost, H₂

It must also be noted that the price of natural gas is much cheaper than either electricity or hydrogen, but because of the price fluctuations due to recent deregulation of gas it is not possible to present a realistic figure. In the opinion of Penner, if the hydrogen production cost component of its total cost could be reduced three fold, it would become a viable alternate energy source. In order to achieve such a three-fold reduction in production costs, several major breakthroughs would have to occur.

1. **Endergonic Reaction** A technological breakthrough which permits 100% conversion efficiency of water by electrolysis fission into the two gases, Hydrogen as fuel and Oxygen as oxidant.
2. **Hydrogen Production in Situ** A technological breakthrough which eliminates the need and cost of hydrogen liquefaction and storage, transmission, and distribution, by producing the fuel in situ, when and where needed.
3. **Exergonic Reaction** A technological breakthrough which yields a 100% efficient energy release from the combination of hydrogen and oxygen into water in an engine that can utilize the heat, steam, or electricity thus produced.
4. **Engine Efficiency** By a combination of the breakthroughs outlined above, 1, 2, and 3 utilized in a highly efficient engine to do work, it is theoretically possible to achieve a 15% to 20% surplus of energy return over energy input.

It is of interest to record that a new invention is now being developed to realise the above outlined goal of cheap, clean renewable and high grade energy. A Thermodynamic Device has been invented which produces hydrogen as fuel, and oxygen as oxidant, from ordinary water or from sea water, eliminating the cost and hazard of liquefaction, storage, transmission, and distribution. The saving of this aspect of the invention alone reduces the total cost of hydrogen by about 25%.

This Thermodynamic Device is based on a new discovery - the efficient electrolytic fission of water into hydrogen gas and oxygen gas by the use of low frequency alternating currents as opposed to the conventional use of direct current, or ultra-high frequency current today. Such gas production from water by electrolytic fission approaches 100% efficiency under laboratory conditions and measurements. No laws of physics are violated in this process.

This Thermodynamic Device has already been tested at ambient pressures and temperatures from sea level to an altitude of 10,000 feet above sea level without any loss of its peak efficiency. The device produces two types of gas bubbles; one type of bubble contains hydrogen gas; the other type contains oxygen gas. The two gases are thereafter easily separable by passive membrane filters to yield pure hydrogen gas, and pure oxygen gas.

The separate gases are now ready to be combined in a chemical fusion with a small activation energy such as that from a catalyst or an electrical spark, and yield energy in the form of heat, or steam, or electricity as needed. When the energy is released by the chemical fusion of hydrogen and oxygen, the exhaust product is clean water. The water exhaust can be released into nature and then renewed in its energy content by natural processes of evaporation, solar irradiation in cloud form, an subsequent precipitation as rain on land or sea, and then collected again as a fuel source. Or, the exhaust water can have its energy content pumped up by artificial processes such as through solar energy acting through photocells. Hence, the exhaust product is both clean and renewable. The fuel hydrogen, and the oxidant oxygen, can be used in any form of heat engine as an energy source if economy is not an important factor. But the practical considerations of maximum efficiency, dictate that a low temperature fuel cell with its direct chemical fusion conversion from gases to electricity offers the greatest economy and efficiency from small power plants of less than 5 kilowatts.

For large power plants, steam and gas turbines are the ideal heat engines for economy and efficiency. With the proper engineering effort, automobiles could be converted rather easily to use water as the main fuel source.

The Thermodynamic Device ("TD") is made up of three principal components:
 Component 1: An electrical function generator which energizes a water cell.
 Component 2: The Thermodynamic Device
 Component 3: A weak electrolyte.

Component 1: The Electrical Function Generator:

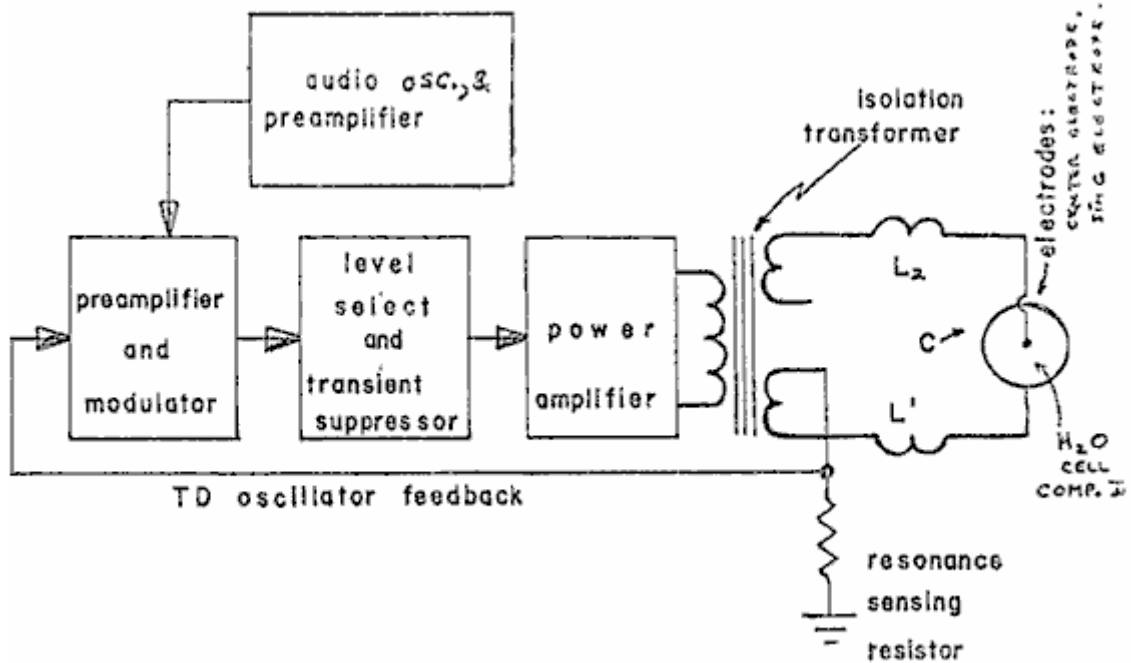

Figure 1: Signal Generator Component Block

This electronic device has a complex alternating current output consisting of an audio frequency (range 20 to 200 Hz) amplitude modulation of a carrier wave (range: 200 to 100,000 Hz). The output is connected by two wires to Component II at the center electrode, and at the ring electrode. See Fig.1. The impedance of this output signal is continuously being matched to the load which is the water solution in Component II.

Component 2: The Thermodynamic Device:

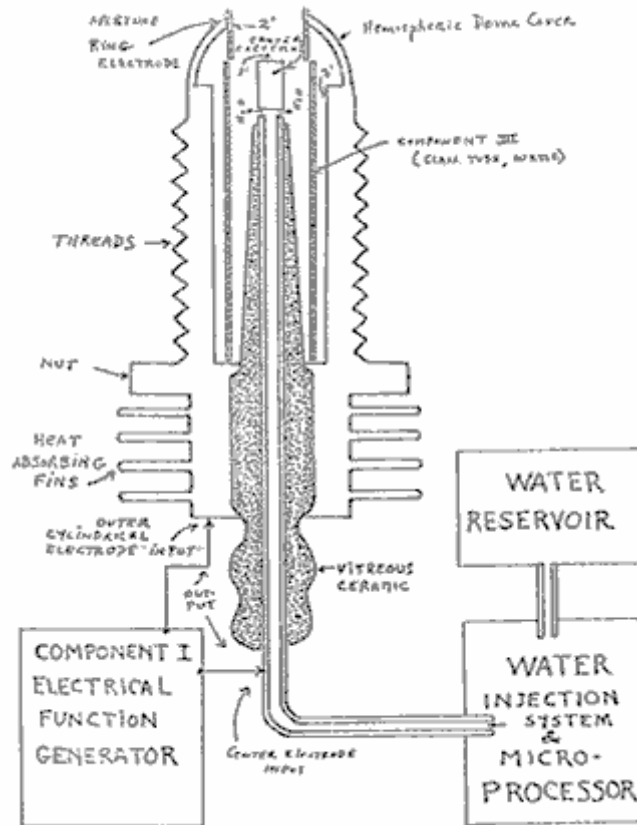

Figure 2: Thermodynamic Device

The TD is fabricated of metals and ceramic in the geometric form of a coaxial cylinder made up of a centered hollow tubular electrode which is surrounded by a larger tubular steel cylinder. These two electrodes comprise the coaxial electrode system energised by Component I. The space between the two electrodes is, properly speaking, Component III which contains the water solution to be electrolysed. The center hollow tubular electrode carries water into the cell, and is further separated from the outer cylindrical electrode by a porous ceramic vitreous material. The space between the two electrodes contains two lengths of tubular Pyrex glass, shown in Figures 2 and 3. The metal electrode surface in contact with the water solution are coated with a nickel alloy.

Component 3: The weak electrolyte water solution:

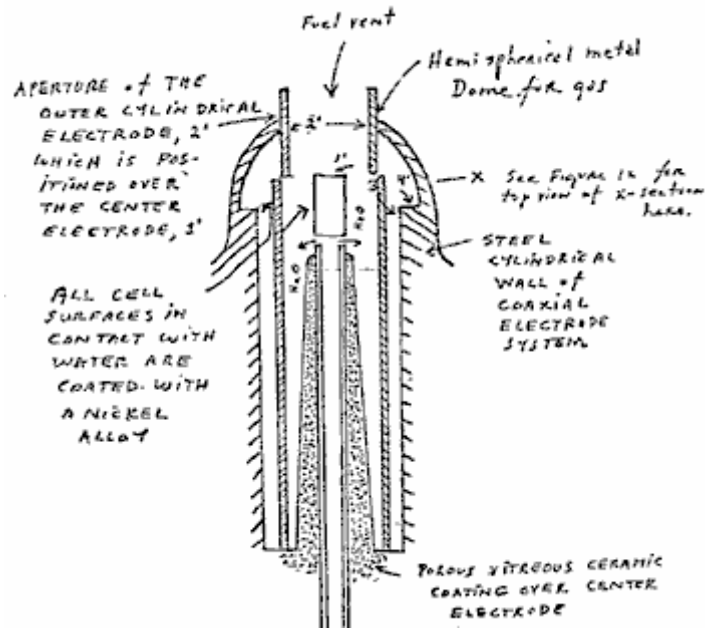

Figure 3: The Water Cell Section of Component 2

This consists of the water solution, the two glass tubes, and the geometry of the containing wall of Component 2. It is the true load for Component 1, and its electrode of Component 2.

The Component 3 water solution is more properly speaking, ideally a 0.1540 M Sodium Chloride solution, and as such, it is a weak electrolyte. In Figure 4 we show the hypothetical tetrahedral structure of water molecule, probably in the form in which the complex electromagnetic waves of Component 1 to see it. The center of mass of this tetrahedral form is the oxygen atom. The geometric arrangement of the p electrons of oxygen probably determine the vectors $i(L1)$ and $i(L2)$ and $i(H1)$ and $i(H2)$ which in turn probably determine the tetrahedral architecture of the water molecule. The p electron configuration of oxygen is shown in Figure 5. Reference to Figure 4, shows that the diagonal of the right side of the cube has at its corner terminations, the positive charge hydrogen (H^+) atoms; and that the left side of the cube diagonal has at its corners, the lone pair electrons, (e^-). It is to be further noted that this diagonal pair has an orthonormal relationship.

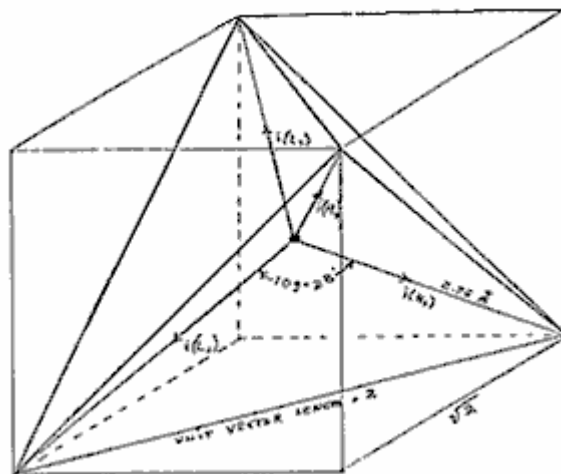

Figure 4: The Water Molecule in Tetrahedral Form:

Hydrogen bonding occurs only along the four vectors pointing to the four vertices of a regular tetrahedron, and in the above drawing we show the four unit vectors along these directions originating from the oxygen atoms at the center. $i(H1)$ and $i(H2)$ are the vectors of the hydrogen bonds formed by the molecule i as a donor molecule. These are assigned to the lone pair electrons. Molecules i are the neighboring oxygen atoms at each vertex of the tetrahedron.

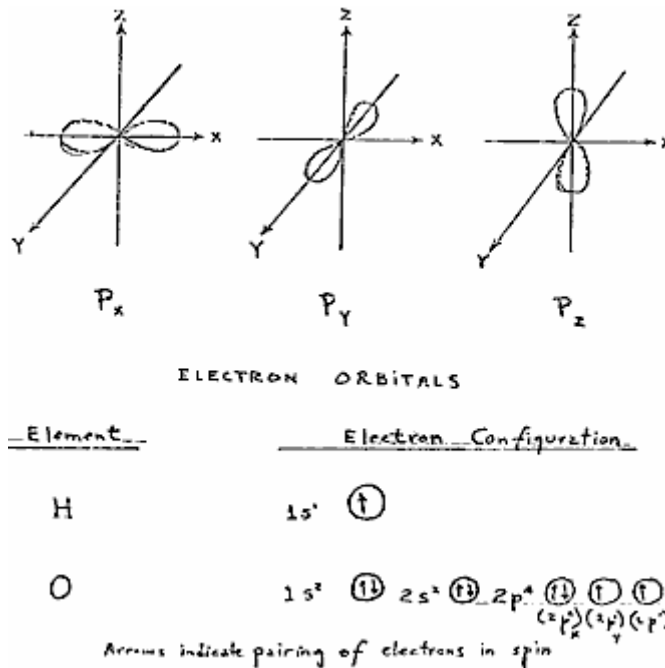

Figure 5: Electron Orbitals

3. Electrothermodynamics

We will now portray the complex electromagnetic wave as the tetrahedral water molecule sees it. The first effect felt by the water molecule is in the protons of the vectors, i (H1) and i (H2). These protons feel the 3-second cycling of the amplitude of the carrier frequency and its associated side bands as generated by Component 1. This sets up a rotation moment of the proton magnetic moment which one can clearly see on the XY plot of an oscilloscope, as an hysteresis loop figure. However, it is noted that this hysteresis loop does not appear in the liquid water sample until all the parameters of the three components have been adjusted to the configuration which is the novel basis of this device. The hysteresis loop gives us a vivid portrayal of the nuclear magnetic relaxation cycle of the proton in water.

The next effect felt by the water molecule is the Component 1 carrier resonant frequency, Fo. At the peak efficiency for electrolysis the value of Fo is 600 Hz +/- 5 Hz.

This resonance however is achieved through control of two other factors. The first is the molal concentration of salt in the water. This is controlled by measuring the conductivity of the water through the built-in current meter of Component 1. There is maintained an idea ratio of current to voltage where I/E = 0.01870 which is an index to the optimum salt concentration of 0.1540 Molal.

The second factor which helps to hold the resonant which helps to hold the resonant frequency at 600 Hz is the gap distance of Y, between the centre electrode, and the ring electrode of Component 2.

This gap distance will vary depending on the size scale of Component 2, but again, the current flow I, is used to set it to the optimal distance when the voltage reads between 2.30 (rms) volts, at resonance Fo, and at molal concentration, 0.1540. The molal concentration of the water is thus seen to represent the electric term of the water molecule and hence its conductivity.

The amplitude modulation of the carrier gives rise to side bands in the power spectrum of the carrier frequency distribution. It is these side bands which give rise to an acoustic vibration of the liquid water, and it is believed, also to the tetrahedral water molecule. The importance of the phonon effect - the acoustic vibration of water in electrolysis - was discovered in a roundabout way. Research work with Component 1 had earlier established that it could be used for the electro-stimulation of hearing in humans. When the output of Component 1 is comprised of flat circular metal plates applied to the head of normal hearing humans, it was found that they could hear pure tones and speech. Simultaneously, acoustic vibration could also be heard by an outside observer with a stethoscope placed near one of the electrodes on the skin. It was observed that the absolute threshold of hearing could be obtained at 0.16 mW (rms), and by calculation that there was an amplitude of displacement of the eardrum of the order of 10⁻¹¹ meter and a corresponding amplitude of the cochlear basilar membrane of 10⁻¹³

meter. Corollary to this finding, I was able to achieve the absolute reversible threshold of electrolysis at a power level of 0.16 mW (rms). By carrying out new calculations, I was able to show that the water was being vibrated with a displacement of the order of 1 Angstrom unit ($= 10^{-10}$ meters). This displacement is of the order of the diameter of the hydrogen atom. Thus it is possible that the acoustic phonons generated by audio side bands of the carrier are able to vibrate particle structures within the unit water tetrahedron.

We now turn to the measurement problem with respect to efficiency of electrolysis. There are four means which can be used to measure the reactant product of water electrolysis. For simple volume measurements, one can use a precision nitrometer such as the Pregl type. For both volume and quantitative analysis one can use the gas chromatography with thermal conductivity detector. For a continuous flow analysis of both volume and gas species the mass spectrometer is very useful. For pure thermodynamic measurements the calorimeter is useful. In our measurements, all four methods were examined, and it was found that the mass spectrometer gave the most flexibility and the greatest precision. In the next section we will describe our measurement using the mass spectrometer.

Protocol

4. Methodology for the Evaluation of the Efficiency of Water Decomposition by Means of Alternating Current Electrolysis

Introduction

All systems used today for the electrolysis of water into hydrogen as fuel, and oxygen as oxidant apply direct current to a strong electrolyte solution. These systems range in efficiency from 50% to 71%. The calculation of energy efficiency in electrolysis is defined as follows:

"The energy efficiency is the ratio of the energy released from the electrolysis products formed (when they are subsequently used) to the energy required to effect electrolysis."

The energy released by the exergonic process under standard conditions is

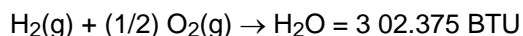

which is 68.315 Kcal/mol. or, 286,021 Joules/mol, and is numerically equal to the enthalpy change (ΔH) for the indicated process. On the other hand, the minimum energy (or useful work input) required at constant temperature and pressure for electrolysis equals the Gibbs free energy change (ΔG).

Penner shows that there is a basic relation derivable from the first and second laws of thermodynamics for isothermal changes which shows that

$$\Delta G = \Delta H - T \Delta S \dots\dots\dots (2)$$

where ΔS represents the entropy change for the chemical reaction and T is the absolute temperature.

The Gibbs free energy change (ΔG) is also related to the voltage (e) required to implement electrolysis by Faraday's equation:

$$e = (\Delta G / 23.06 n) \text{ volts} \dots\dots\dots (3)$$

where ΔG is in Kcal/mol, and n is the number of electrons (or equivalents) per mole of water electrolysed and has the numerical value 2 in the equation (endergonic process),

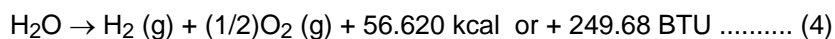

Therefore, according to equation (2) at atmospheric pressure, and 300°K:

$$\Delta H = 68.315 \text{ kcal/mol of H}_2\text{O, and}$$

$$\Delta G = 56.620 \text{ kcal / mol of H}_2\text{O} = 236,954 \text{ J/mol H}_2\text{O for the electrolysis of liquid water.}$$

In view of these thermodynamic parameters for the electrolysis of water into gases, hydrogen and oxygen, we can establish by Eq.(2) numeric values where,

$$\Delta G = 236.954 \text{ J/mol H}_2\text{O under standard conditions. Thus}$$

$$n = \Delta G \text{ (J/mol)} / \Delta Ge \text{ (J/mol)} = <1 \text{ (5)}$$

where ΔGe is the electrical energy input to H_2O (1) in Joules, and ΔG is the Gibbs free energy of H_2O . The conversion between the two quantities is one Watt second (Ws) = one Joule.

Or, in terms of gas volume, as hydrogen, produced and measured,

$$n = \text{Measured } H_2 \text{ (cc)} / \text{Ideal } H_2 \text{ (cc)} = <1 \text{ (6)}$$

In accordance with these general principles we present the methodology followed in evaluating the electrolytic of alternating current on H_2O in producing the gases, hydrogen and oxygen. No attempt has been made to utilize these gases according to the process of Eq.(1). It is to be noted that the process

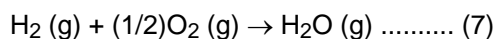

yields only 57.796 kcal /mol. Eq.(7) shows that per mole of gases water formed at $300^\circ K$, the heat released is reduced from the 68.315 kcal/mol at Eq. (1) by the molar heat of evaporation of water at $300^\circ K$ (10.5 kcal) and the overall heat release is 57.796 kcal/mol if H_2O (g) is formed at $300^\circ K$.

In the following sections we describe the new method of electrolysis by means of alternating current, and the exact method and means used to measure the endergonic process of Eq.(4) and the governing Eq.(2) and Eq.(5).

5. Thermodynamic Measurement

In order to properly couple Component 2 to a mass spectrometer, one requires a special housing around Component 2 which will capture the gases produced, and permit these to be drawn under low vacuum into the mass spectrometer. Therefore a stainless steel and glass chamber was built to contain Component 2, and provision made to couple it directly through a CO_2 water-trap to the mass spectrometer with the appropriate stainless steel tubing. This chamber is designated as Component 4. Both the mass spectrometer and Component 4 were purged with helium and evacuated for a two hour period before any gas samples were drawn. In this way, contamination was minimized. The definitive measurement were done at Gollob Analytical Services in Berkeley Heights, New Jersey.

We now describe the use of Component 1 and how its energy output to Component 2 is measured. The energy output of Component 1 is an amplitude-modulated alternating current looking into a highly non-linear load, i.e., the water solution. Component 1 is so designed that at peak load it is in resonance across the system (Components 1, 2, and 3) and the vector diagrams show that the capacitive reactance, and the inductance reactance are almost exactly 180° out of phase with each other, and so the net power output is reactive (the dissipative power is very small). This design ensures minimum power losses across the entire output system. In the experiments to be described, the entire emphasis is placed on achieving the maximum gas yield (credit) in exchange for the minimum applied electrical energy.

The most precise way to measure the applied energy from Component 1 to Component 2 and Component 3, is to measure the power, P, in watts, W. Ideally this should be done with a precision wattmeter, but since we were interested in following the voltage and current separately, it was decided not to use the watt meter. Separate meters were used to continuously monitor the current and the volts.

This is done by precision measurement of the volts across Component 3 as root mean square (rms) volts; and the current flowing in the system as rms amperes. Precisely calibrated instruments were used to take these two measurements. A typical set of experiments using water in the form of 0.9% saline solution 0.1540 molar to obtain high efficiency hydrolysis gave the following results:

$$\text{rms Current} = I = 25\text{mA to } 38 \text{ mA (0.025 A to } 0.038 \text{ A.)}$$

$$\text{rms Volts} = E = 4.0 \text{ Volts to } 2.6 \text{ Volts}$$

The resultant ration between current and voltage is dependent on many factors such as the gap distance between the center and ring electrodes, dielectric properties of the water, conductivity properties of the water, equilibrium states, isothermal conditions, materials used, and even the pressure of clathrates. The above current and voltage values reflect the net effect of various combinations of such parameters. When one takes the product of rms current, and rms volts, one has a measure of the power, P in watts.

$$P = I \times E = 25 \text{ mA} \times 4.0 \text{ volts} = 100 \text{ mW (0.1 W)}$$

and $P = I \times E = 38 \text{ mA} \times 2.6 \text{ volts} = 98.8 \text{ mW} (0.0988 \text{ W})$

At these power levels (with load), the resonant frequency of the system is 600 Hz (plus or minus 5 Hz) as measured on a precision frequency counter. The waveform was monitored for harmonic content on an oscilloscope, and the nuclear magnetic relaxation cycle was monitored on an XY plotting oscilloscope in order to maintain the proper hysteresis loop figure. All experiments were run so that the power in watts, applied through Components 1, 2, and 3 ranged between 98.8 mW to 100 mW.

Since by the International System of Units 1971 (SI), one Watt-second (Ws) is exactly equal to one Joule (J), our measurements of efficiency used these two yardsticks ($1 \text{ Ws} = 1 \text{ J}$) from the debit side of the measurement.

The energy output of the system is, of course, the two gases, Hydrogen (H_2) and Oxygen, $(1/2)\text{O}_2$, and this credit side was measured in two laboratories, on two kinds of calibrated instruments, namely gas chromatography machine, and mass spectrometer machine.

The volume of gases H_2 and $(1/2)\text{O}_2$ was measured as produced under standard conditions of temperature and pressure in unit time, i.e., in cubic centimeters per minute (cc/min), as well as the possibility contaminating gases, such as air oxygen, nitrogen and argon, carbon monoxide, carbon dioxide, water vapor, etc.

The electrical and gas measurements were reduced to the common denominator of Joules of energy so that the efficiency accounting could all be handled in one currency. We now present the averaged results from many experiments. The standard error between different samples, machines, and locations is at +/- 10%, and we only use the mean for all the following calculations.

2. Thermodynamic Efficiency for the Endergonic Decomposition of Liquid Water (Salinized) to Gases Under Standard Atmosphere (754 to 750 mm. Hg) and Standard Isothermal Conditions @ $25^\circ\text{C} = 77^\circ\text{F} = 298.16^\circ\text{K}$, According to the Following Reaction:



As already described, ΔG is the Gibbs function. We convert Kcal to our common currency of Joules by the formula, One Calorie = 4.1868 Joules

$$\Delta G = 56.620 \text{ Kcal} \times 4.1868 \text{ J} = 236,954/\text{J/mol of H}_2\text{O where 1 mole} = 18 \text{ gr.} \dots\dots\dots (11)$$

ΔG_e = the electrical energy required to yield an equivalent amount of energy from H_2O in the form of gases H_2 and $(1/2)\text{O}_2$.

To simplify our calculation we wish to find out how much energy is required to produce the 1.0 cc of H_2O as the gases H_2 and $(1/2)\text{O}_2$. There are (under standard conditions) 22,400 cc = V of gas in one mole of H_2O . Therefore

$$\Delta G / V = 236,954 \text{ J} / 22,400 \text{ cc} = 10.5783 \text{ J/cc.} \dots\dots\dots (12)$$

We now calculate how much electrical energy is required to liberate 1.0 cc of the H_2O gases (where $\text{H}_2 = 0.666$ parts, and $(1/2)\text{O}_2 = 0.333$ parts by volume) from liquid water. Since $P = 1 \text{ Ws} = 1 \text{ Joule}$, and $V = 1.0 \text{ cc}$ of gas = 10.5783 Joules, then

$$PV = 1 \text{ Js} \times 10.5783 \text{ J} = 10.5783 \text{ Js, or,} = 10.5783 \text{ Ws} \dots\dots\dots (13)$$

Since our experiments were run at 100 mW (0.1 W) applied to the water sample in Component II, III, for 30 minutes, we wish to calculate the ideal (100% efficient) gas production at this total applied power level. This is,

$$0.1 \text{ Ws} \times 60 \text{ sec} \times 30 \text{ min} = 180,00 \text{ Joules (for 30 min.)}. \text{ The total gas production at ideal 100\% efficiency is } 180 \text{ J}/10.5783 \text{ J/cc} = 17.01 \text{ cc H}_2\text{O} (g)$$

We further wish to calculate how much hydrogen is present in the 17.01 cc H_2O (g).

$$17.01 \text{ cc H}_2\text{O} (g) \times 0.666 \text{ H}_2 (g) = 11.329 \text{ cc H}_2 (g) \dots\dots\dots (14)$$

$$17.01 \text{ cc H}_2\text{O} (g) \times 0.333 (1/2)\text{O}_2 (g) = 5.681 \text{ cc } (1/2)\text{O}_2 (g)$$

Against this ideal standard of efficiency of expected gas production, we must measure the actual amount of gas produced under: (1) Standard conditions as defined above, and (2) 0.1 Ws power applied over 30 minutes. In our experiments, the mean amount of H₂ and (1/2)O₂ produced, as measured on precision calibrated GC, and MS machines in two different laboratories, where SE is +/- 10%, is,

Measured Mean = 10.80 cc H₂ (g)

Measured Mean = 5.40 cc (1/2) cc (1/2)O₂ (g)

Total Mean = 16.20 cc H₂O (g)

The ratio, n, between the ideal yield, and measured yield,

Measured H₂ (g) / Ideal H₂ (g) = 10.80 cc / 11.33 cc = 91.30%

6. Alternative Method for Calculating Efficiency Based on the Faraday Law of Electrochemistry

This method is based on the number of electrons that must be removed, or added to decompose, or form one mole of, a substance of valence one. In water (H₂O), one mole has the following weight:

H = 1.008 gr /mol

H = 1.008 gr /mol

O = 15.999 gr/mol

Thus, 1 mol H₂O = 18.015 gr/mol

For a univalent substance, one gram/mole contains 6.022×10^{23} electrons = N = Avogadro's Number. If the substance is divalent, trivalent, etc., N is multiplied by the number of the valence. Water is generally considered to be of valence two.

At standard temperature and pressure ("STP") one mole of a substance contains 22.414 cc, where Standard temperature is $273.15^{\circ}\text{K} = 0^{\circ}\text{C} = \text{T}$. Standard Pressure (one atmosphere) = 760 mm Hg = P.

One Faraday ("F") is 96,485 Coulombs per mole (univalent).

One Coulomb ("C") is defined as:

$1 \text{ N} / 1 \text{ F} = 6.122 \times 10^{23} \text{ Electrons} / 96,485 \text{ C} = \text{one C}$

The flow of one C/second = one Ampere.

One C x one volt = one Joule second (Js).

One Ampere per second @ one volt = one Watt = one Joule.

In alternating current, when amps (I) and Volts (E) are expressed in root mean squares (rms), their product is Power in watts.

$P = IE \text{ watts (Watts = Amps x Volts)}$.

With these basic definitions we can now calculate efficiency of electrolysis of water by the method of Faraday's electrochemistry.

The two-electron model of water requires 2 moles of electrons for electrolysis ($2 \times 6.022 \times 10^{23}$), or two Faraday quantities ($2 \times 96,485 = 192,970 \text{ Coulombs}$).

The amount of gas produced will be:

H₂ = 22,414 cc /mol at STP

(1/2)O₂ = 11,207 cc / mol at STP

Gases = 33.621 cc / mol H₂O (g)

The number of coulombs required to produce one cc of gases by electrolysis of water:

$193,970 \text{ C} / 33621 \text{ C} = 5.739567 \text{ C per cc gases}$.

Then, $5,739 \text{ C /cc /sec} = 5.739 \text{ amp/sec/cc}$. How many cc of total gases will be produced by 1 A/sec?

0.1742291709 cc.

How many cc of total gases will be produced by 1 A/min ?

10.45375 cc/min

What does this represent as the gases H_2 and O_2 ?

$(1/2)\text{O}_2 = 3.136438721 \text{ cc/Amp/min}$.

$\text{H}_2 = 6.2728 \text{ cc/Amp /min}$.

We can now develop a Table for values of current used in some of our experiments, and disregarding the voltage as is done conventionally.

1. Calculations for 100 mA per minute:

Total Gases = 1.04537 cc/min

$\text{H}_2 = 0.6968 \text{ cc/min}$

$(1/2)\text{O}_2 = 0.3484 \text{ cc/min}$

30 min. $\text{H}_2 = 20.9054 \text{ cc/ 30 minutes}$

2. Calculations for 38 mA per minute:

Total Gases = 0.3972 cc/ 30 minutes

$\text{H}_2 = 0.2645 \text{ cc/min}$

$(1/2)\text{O}_2 = 0.1323 \text{ cc/min}$

30 min. $\text{H}_2 = 7.9369 \text{ cc/min}$

3. Calculations for 25mA per minute:

30 min. $\text{H}_2 = 5.2263 \text{ cc/ minute}$

7. Conclusion

Fig.6 and Fig.7 [not available] show two of the many energy production systems that may be configured to include renewable sources and the present electrolysis technique. Figure 6 shows a proposed photovoltaic powered system using a fuel cell as the primary battery. Assuming optimum operating conditions using 0.25 watt seconds of energy from the photovoltaic array would enable 0.15 watt-seconds to be load.

Figure 7 depicts several renewable sources operating in conjunction with the electrolysis device to provide motive power for an automobile.

US Patent 4,394,230

DATE 19th July 1983

INVENTOR: HENRY K. PUHARICH

METHOD AND APPARATUS FOR SPLITTING WATER MOLECULES

This is a re-worded extract from the United States Patent number 4,394,230. It describes how Henry Puharich was able to split water into hydrogen and oxygen gasses by a process which used very little input power.

ABSTRACT

Disclosed herein is a new and improved thermodynamic device to produce hydrogen gas and oxygen gas from ordinary water molecules or from seawater at normal temperatures and pressure. Also disclosed is a new and improved method for electrically treating water molecules to decompose them into hydrogen gas and oxygen gas at efficiency levels ranging between approximately 80-100%. The evolved hydrogen gas may be used as a fuel; and the evolved oxygen gas may be used as an oxidant.

Inventors: Puharich; Henry K. (Rte. 1, Box 97, Delaplane, VA 22025)

BACKGROUND OF THE INVENTION

The scientific community has long realised that water is an enormous natural energy resource, indeed an inexhaustible source, since there are over 300 million cubic miles of water on the earth's surface, all of it a potential source of hydrogen for use as fuel. In fact, more than 100 years ago Jules Verne prophesied that water eventually would be employed as a fuel and that the hydrogen and oxygen which constitute it would furnish an inexhaustible source of heat and light.

Water has been split into its constituent elements of hydrogen and oxygen by electrolytic methods, which have been extremely inefficient, by thermochemical extraction processes called thermochemical water-splitting, which have likewise been inefficient and have also been inordinately expensive, and by other processes including some employing solar energy. In addition, artificial chloroplasts imitating the natural process of photosynthesis have been used to separate hydrogen from water utilising complicated membranes and sophisticated artificial catalysts. However, these artificial chloroplasts have yet to produce hydrogen at an efficient and economical rate.

These and other proposed water splitting techniques are all part of a massive effort by the scientific community to find a plentiful, clean, and inexpensive source of fuel. While none of the methods have yet proved to be commercially feasible, they all share in common the known acceptability of hydrogen gas as a clean fuel, one that can be transmitted easily and economically over long distances and one which when burned forms water.

SUMMARY OF THE PRESENT INVENTION

In classical quantum physical chemistry, the water molecule has two basic bond angles, one angle being 104° , and the other angle being $109^\circ 28'$. The present invention involves a method by which a water molecule can be energised by electrical means so as to shift the bond angle from the 104° degree configuration to the $109^\circ 28'$ tetrahedral geometrical configuration.

An electrical function generator (Component 1) is used to produce complex electrical wave form frequencies which are applied to, and match the complex resonant frequencies of the tetrahedral geometrical form of water. It is this complex electrical wave form applied to water which is contained in a special thermodynamic device (Component II) which shatters the water molecule by resonance into its component molecules --- hydrogen and oxygen.

The hydrogen, in gas form, may then be used as fuel; and oxygen, in gas form is used as oxidant. For example, the thermodynamic device of the present invention may be used as a hydrogen fuel source for any existing heat engine --- such as, internal combustion engines of all types, turbines, fuel cell, space heaters, water heaters, heat exchange systems, and other such devices. It can also be used for the desalination of sea water, and other water purification purposes. It can also be applied to the development of new closed cycle heat engines where water goes in as fuel, and water comes out as a clean exhaust.

For a more complete understanding of the present invention and for a greater appreciation of its attendant advantages, reference should be made to the following detailed description taken in conjunction with the accompanying drawings.

DESCRIPTION OF THE DRAWINGS:

Fig.1 is a schematic block diagram illustrating the electrical function generator, Component I, employed in the practice of the present invention:

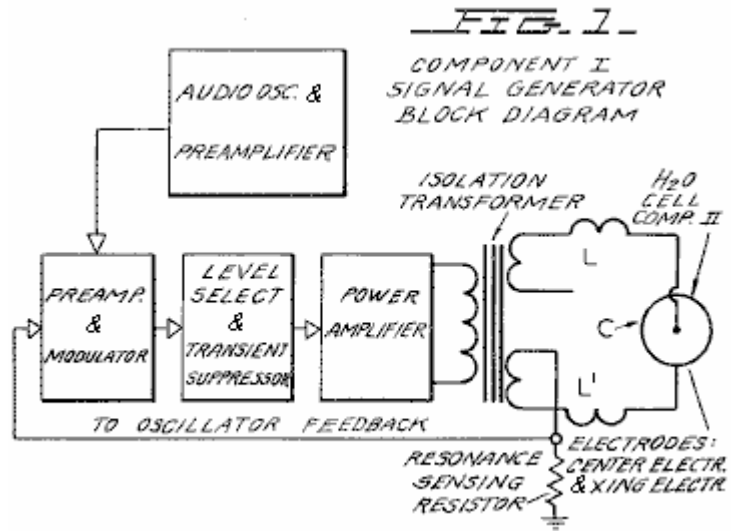

Fig.2 is a schematic illustration of the apparatus of the present invention, including a cross sectional representation of the thermodynamic device, Component II:

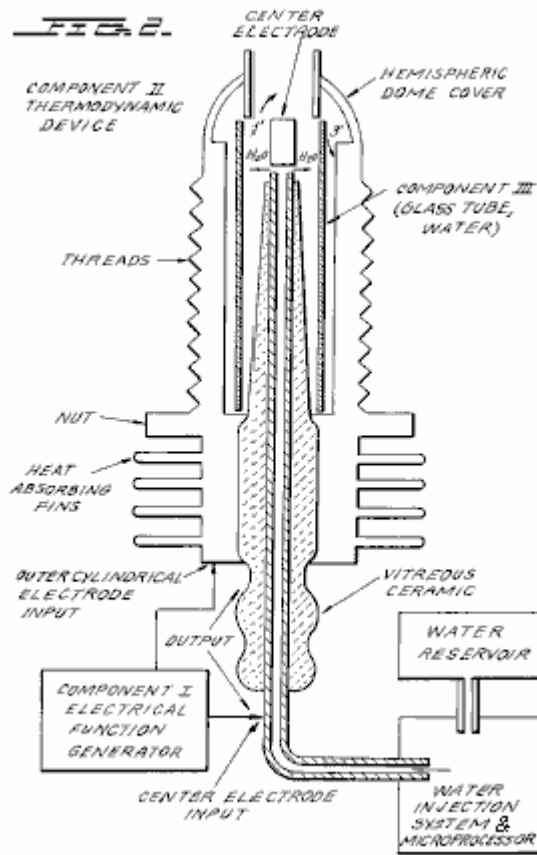

Fig.3 is a cross-sectional view of Component III of the present invention, the water cell section of Component II:

FIG. 3.

COMPONENT III.
THE WATER CELL SECTION
OF COMPONENT II

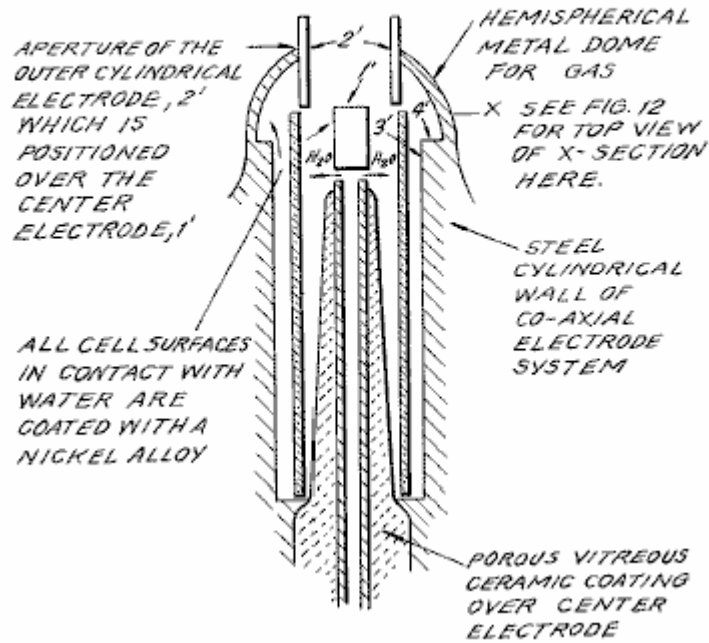

Fig.4 is an illustration of the hydrogen covalent bond:

FIG. 4.



Fig.4A is an illustration of the hydrogen bond angle:

FIG. 4A.

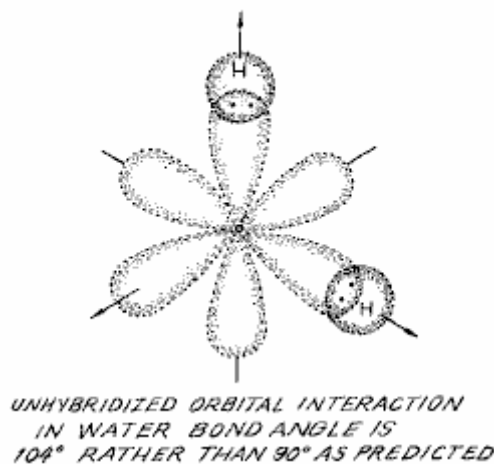
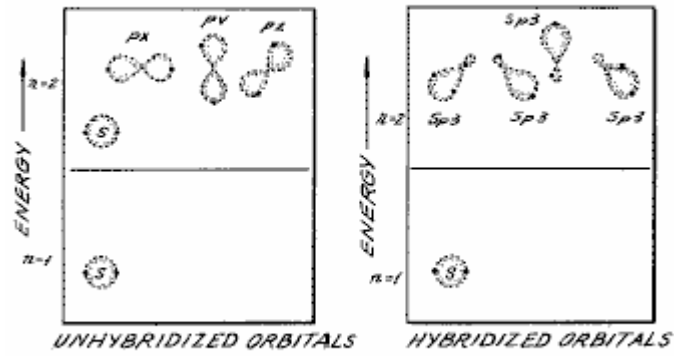

Fig.4B is an illustration of hybridised and un-hybridised orbitals:

FIG. 4B.



FORMATION OF sp^3 HYBRID ORBITALS

Fig.4C is an illustration of the geometry of methane ammonia and water molecules:

FIG. 4C.

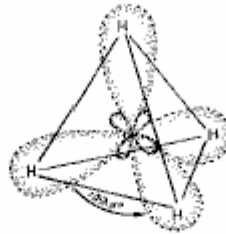

HYBRIDIZED METHANE MOLECULE CH_4



HYBRIDIZED AMMONIA MOLECULE NH_3

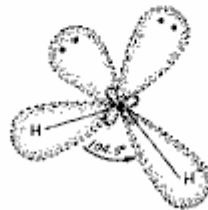

HYBRIDIZED WATER MOLECULE H_2O

GEOMETRY OF METHANE,
AMMONIA, AND WATER MOLECULES

Fig.5 is an illustration of an amplitude modulated carrier wave:

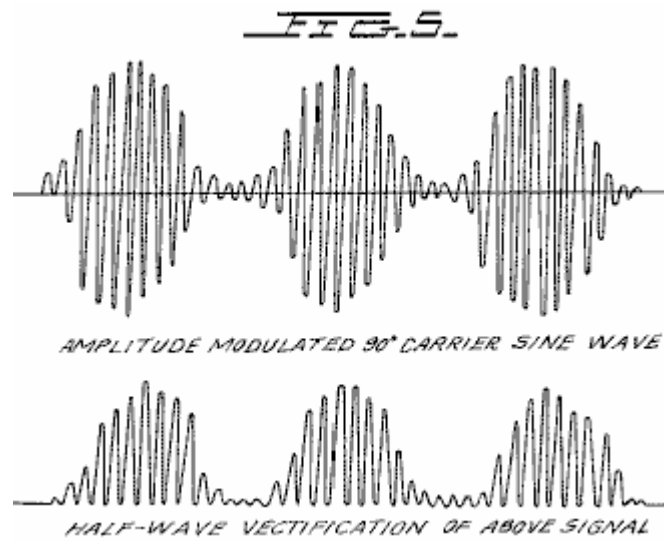

Fig.6 is an illustration of a ripple square wave:

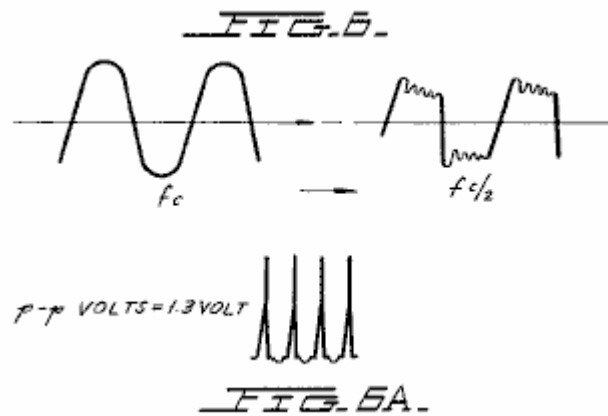

Fig.6A is an illustration of unipolar pulses.

Fig.7 is a diagram showing ion distribution at the negative electrode:

FIG. 7.

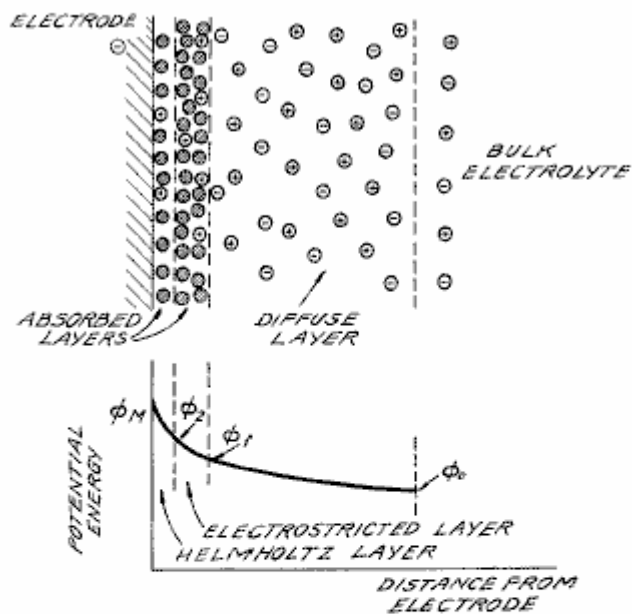

DIAGRAM OF THE DOUBLE LAYER CLOSE TO A NEGATIVE ELECTRODE. THE POTENTIAL ENERGY OF POSITIVE IONS IN THIS REGION WHEN NO CURRENT IS FLOWING IS SHOWN IN THE LOWER DIAGRAM. $\phi_M - \phi_2$ IS THE ELECTRON TRANSFER POTENTIAL; $\phi_2 - \phi_1$ IS RELATED TO THE ACTIVATION OVERPOTENTIAL; AND $\phi_1 - \phi_0$ IS RELATED TO THE DIFFUSION OVERPOTENTIAL.

KEY

- ⊙ SOLVENT MOLECULE = H_2O
- ⊕ POSITIVE ION = H^+
- ⊖ NEGATIVE ION = O^-

Fig.8 is an illustration of tetrahedral bonding orbitals:

FIG. 8.

EQUIVALENT TETRAHEDRAL BONDING ORBITALS OF WATER

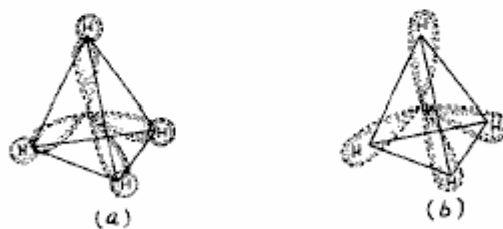
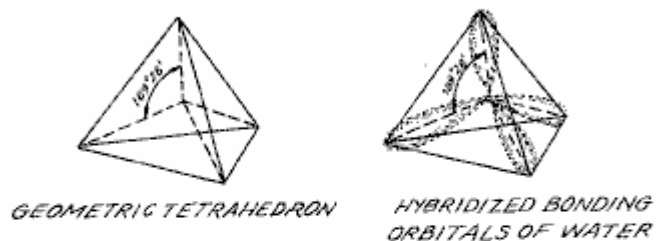

METHANE OVERLAP OF SPHERICAL 1s ORBITAL OF HYDROGEN WITH sp³ BONDING ORBITALS OF CARBON (a) RESULTS IN EQUIVALENT SIGMA BONDS, THE MOLECULAR ORBITALS OF (b).

Fig.9 is an illustration of water molecules:

FIG. 9.

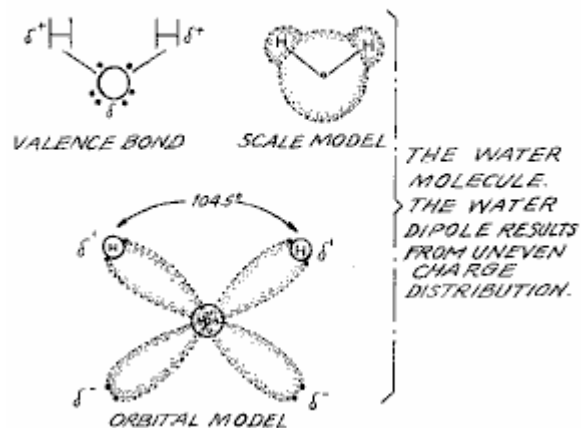

Fig.10 is an illustration of productive and non-productive collisions of hydrogen with iodine:

FIG. 10.

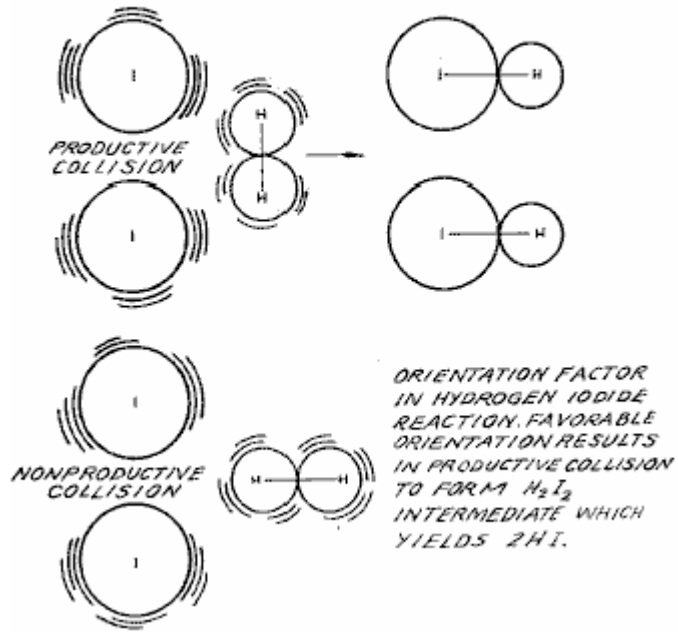

Fig.11 is a wave form found to be the prime characteristic for optimum efficiency:

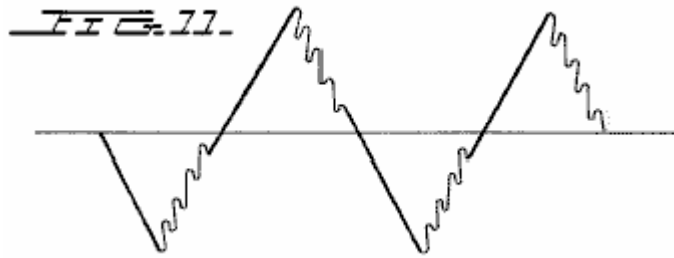

Fig.12 is an illustration of pearl chain formation:

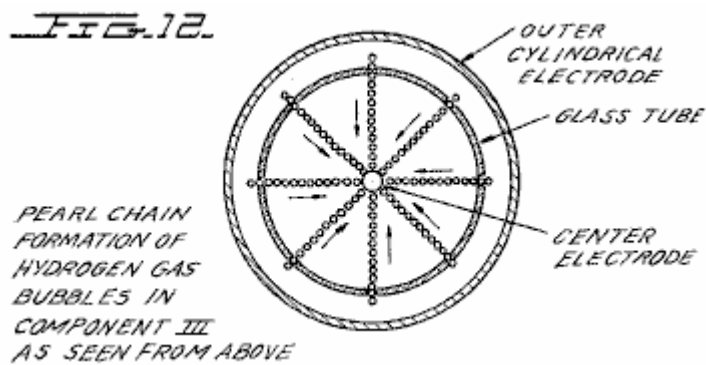
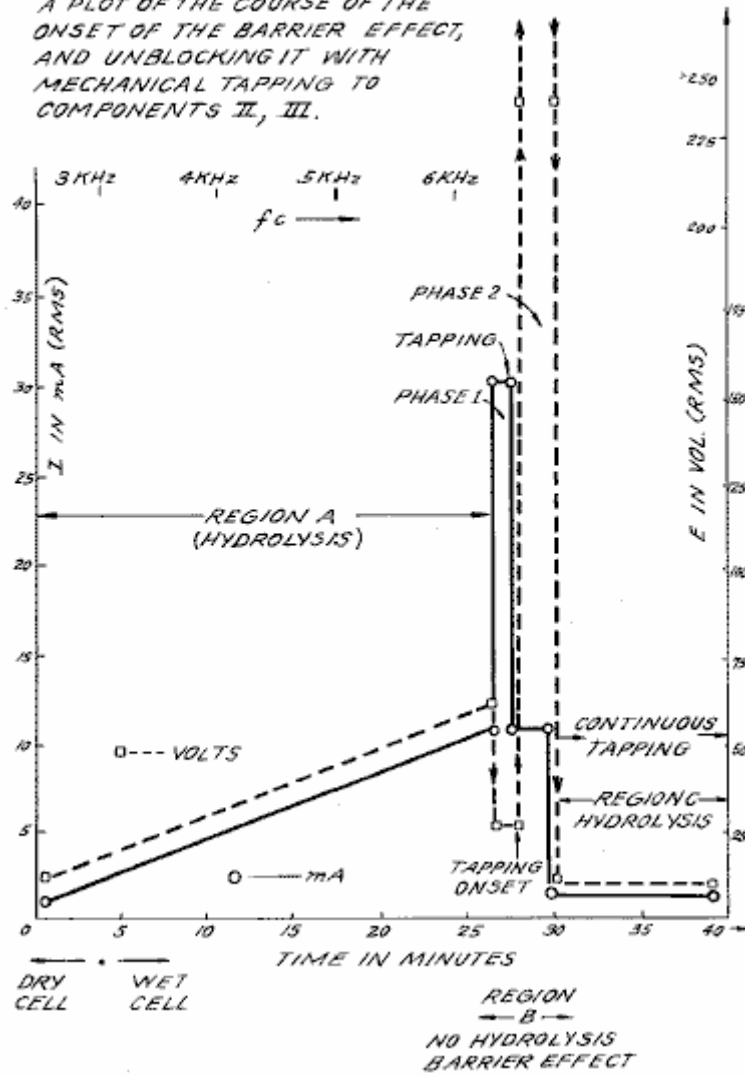

Fig.13 is a plot of the course of the onset of the barrier effect and the unblocking of the barrier effect:

FIG. 13

A PLOT OF THE COURSE OF THE ONSET OF THE BARRIER EFFECT, AND UNBLOCKING IT WITH MECHANICAL TAPPING TO COMPONENTS II, III.



Figs.14A, B, and C are energy diagrams for exergonic reactions:

FIG. 14A.
 (a) AN EXERGONIC REACTION. PRODUCTS HAVE A LOWER POTENTIAL ENERGY THAN REACTANTS, THEREFORE, ENERGY IS RELEASED.

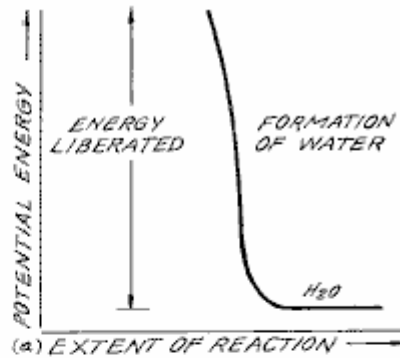

FIG. 14B.
 (b) AN ENDERGONIC REACTION. PRODUCTS HAVE A HIGHER POTENTIAL ENERGY THAN REACTANTS, CAUSING ENERGY TO BE CONSUMED.

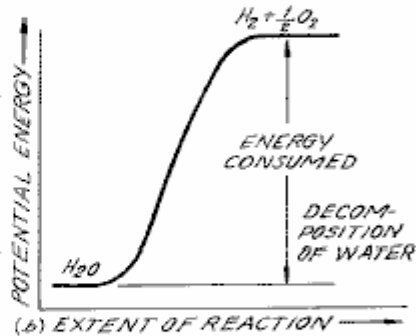
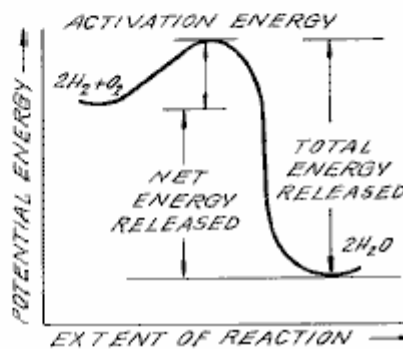

FIG. 14C.
 ENERGY DIAGRAM FOR EXERGONIC REACTION. ACTIVATION ENERGY IS BARRIER TO BE OVERCOME FOR REACTION TO PROCEED, & IS SUPPLIED AS A "SPARK" TO THE GASES TO GET IGNITION.



DETAILED DESCRIPTION OF INVENTION:

Section 1:

Apparatus of Invention;

The apparatus of the invention consists of three components, the Electrical Function Generator, the Thermodynamic Device, and the Water Cell.

Component I: The Electrical Function Generator;

This device has an output consisting of an audio frequency (range 20 to 200 Hz) amplitude modulation of a carrier wave (range 200 Hz to 100,000 Hz). The impedance of this output signal is continuously being matched to the load which is the second component, the thermodynamic device. The electrical function generator represents a novel application of circuitry disclosed in my earlier U.S. Pat. Nos. 3,629,521; 3,563,246; and 3,726,762, which are incorporated by reference herein. See **Fig.1** for the block diagram of Component I.

Component II: The Thermodynamic Device;

The thermodynamic device is fabricated of metals and ceramic in the geometric form of coaxial cylinder made up of a central hollow tubular electrode which is surrounded by a larger tubular steel cylinder, said two electrodes comprising the coaxial electrode system which forms the load of the output of the electrical function generator, Component I. Said central hollow tubular electrode carries water, and is separated from the outer cylindrical electrode by a porous ceramic vitreous material. Between the outer surface of the insulating ceramic vitreous material, and the inner surface of the outer cylindrical electrode exists a space to contain the water to be electrolysed. This water cell space comprises the third component (Component III) of the invention. It contains two lengths of tubular Pyrex glass, shown in **Fig.2** and **Fig.3**. The metal electrode surfaces of the two electrodes which are in contact with the water are coated with a nickel alloy.

The coaxial electrode system is specifically designed in materials and geometry to energise the water molecule to the end that it might be electrolysed. The central electrode is a hollow tube and also serves as a conductor of water to the Component III cell. The central tubular electrode is coated with a nickel alloy, and surrounded with a porous vitreous ceramic and a glass tube with the exception of the tip that faces the second electrode. The outer cylindrical electrode is made of a heat conducting steel alloy with fins on the outside, and coated on the inside with a nickel alloy. The central electrode, and the cylindrical electrode are electrically connected by an arching dome extension of the outer electrode which brings the two electrodes at one point to a critical gap distance which is determined by the known quenching distance for hydrogen. See **Fig.2** for an illustration of Component II.

Component III: The Water Cell;

The water cell is a part of the upper end of Component II, and has been described. An enlarged schematic illustration of the cell is presented in FIG. 3. The Component III consists of the water and glass tubes contained in the geometrical form of the walls of cell in Component II, the thermodynamic device. The elements of a practical device for the practice of the invention will include:

(A) Water reservoir; and salt reservoir; and/or salt

(B) Water injection system with microprocessor or other controls which sense and regulate (in accordance with the parameters set forth here:

- a. Carrier frequency
- b. Current
- c. Voltage
- d. RC relaxation time constant of water in the cell
- e. Nuclear magnetic relaxation constant of water
- f. Temperature of hydrogen combustion
- g. Carrier wave form
- h. RPM of an internal combustion engine (if used)
- i. Ignition control system
- j. Temperature of region to be heated;

(C) An electrical ignition system to ignite the evolved hydrogen gas fuel.

The important aspects of Component III are the tubular vitreous material, the geometry of the containing walls of the cell, and the geometrical forms of the water molecules that are contained in the cell. A further important aspect of the invention is the manipulation of the tetrahedral geometry of the water molecule by the novel methods and means which will be more fully described in the succeeding sections of this specification.

The different parts of a molecule are bound together by electrons. One of the electron configurations which can exist is the covalent bond which is achieved by the sharing of electrons. A molecule of hydrogen gas, H₂ is the smallest representative unit of covalent bonding, as can be seen in **Fig.4**. The molecule of hydrogen gas is formed by the overlap and pairing of 1s orbital electrons. A new molecular orbit is formed in which the shared electron pair orbits both nuclei as shown in **Fig.4**. The attraction of the nuclei for the shared electrons holds the atoms together in a covalent bond.

Covalent bonds have direction. The electronic orbitals of an uncombined atom can change shape and direction when that atom becomes part of a molecule. In a molecule in which two or more covalent bonds are present the molecular geometry is dictated by the bond angles about the central atom. The outermost lone pair (non-bonding) electrons profoundly affect the molecular geometry.

The geometry of water illustrates this concept. In the ground state, oxygen has the outer shell configuration:

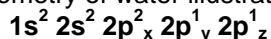

In water the 1s electrons from two hydrogen atoms bond with the 2p_y and 2p_z electrons of oxygen. Since p orbitals lie at right angles to each other (see **Fig.4A**), a bond angle of 90° might be expected. However, the bond angle is found experimentally to be approximately 104°. Theoretically this is explained by the effect of lone pair electrons on hybridised orbitals.

Combined or hybrid orbitals are formed when the excitement of 2s electrons results in their promotion from the ground state to a state energetically equivalent to the 2p orbitals. The new hybrids are termed sp³ from the combination of one s and three p orbitals (See **Fig.4B**). Hybrid sp³ orbitals are directed in space from the centre of a regular tetrahedron toward the four corners. If the orbitals are equivalent the bond angle will be 109°28' (See **Fig.15**) consistent with the geometry of a tetrahedron. In the case of water two of the orbitals are occupied by non-bonding electrons (See **Fig.4C**). There is greater repulsion of these lone pair electrons which orbit only one nucleus, compared to the repulsion of electrons in bonding orbitals which orbit two nuclei. This tends to increase the angle between non-bonding orbitals so that it is greater than 109°, which pushes the bonding orbitals together, reducing the bond angle to 104°. In the case of ammonia, NH₃ where there is only one lone pair, the repulsion is

not so great and the bond angle is 107° . Carbon forms typical tetrahedral forms and components the simplest being the gas methane, CH_4 (See **Fig.4C** and **Fig.8**). The repulsion of lone pair electrons affects charge distribution and contributes to the polarity of a covalent bond. (See **Fig.16**)

As demonstrated in succeeding sections of this patent specification, a significant and novel aspect of this invention is the manipulation, by electronic methods and means, of the energy level of the water molecule, and the transformation of the water molecule into, and out of, the geometrical form of the tetrahedron. This is made possible only by certain subtle dynamic interactions among the Components I, II, and III of the present invention.

Section 2:

Electrodynamics (Pure Water);

The electrodynamics of Components I, II, and III, will be described individually and in interaction during the progress of pure water reaction rate in time. The reactions of saline water will be described in Section 3. It is to be noted that the output of Component I automatically follows the seven stages (hereinafter Stages A-F) of the reaction rate by varying its parameters of resonant carrier frequency, wave form, current voltage and impedance. All the seven states of the reaction herein described are not necessary for the practical operation of the system, but are included in order to explicate the dynamics and novel aspects of the invention. The seven stages are applicable only to the electrolysis of pure water.

Stage A:

Dry Charging of Component II by Component I;

To make the new system operational, the Component I output electrodes are connected to component II, but no water is placed in the cell of Component III. When Component I output is across the load of Component II we observe the following electrical parameters are observed:

Range of current (I) output with (dry) load: 0 to 25 mA (milliamps) rms.

Range of voltage (E) output with (dry) load: 0 to 250 Volts (AC) rms.

There is no distortion of the amplitude modulated (AM), or of the sine wave carrier whose central frequency, f_c , ranges between 59,748 Hz to 66, 221 Hz, with f_c average = 62, 985 Hz

The carrier frequency varies with the power output in that f_c goes down with an increase in amperes (current). The AM wave form is shown in **Fig.5**. It is to be noted here that the electrical function generator, Component I, has an automatic amplitude modulation volume control which cycles the degree of Amplitude Modulation from 0% to 100%, and then from 100% to 0% every 3.0 seconds. This cycle rate of 3.0 seconds corresponds to the nuclear spin relaxation time, τ /sec, of the water in Component III. The meaning of this effect will be discussed in greater detail in a later section.

In summary, the principal effects to be noted during Stage A -dry charging of Component II are as follows:

- a. Tests the integrity of Component I circuitry.
- b. Tests the integrity of the coaxial electrodes, and the vitreous ceramic materials of Component II and Component III.
- c. Electrostatic cleaning of electrode and ceramic surfaces.

Stage B:

Initial operation of Component I, Component II, and with Component III containing pure water. There is no significant electrolysis of water during Stage B. However, in Stage B the sine wave output of Component I is shaped to a rippled square wave by the changing RC constant of the water as it is treated;

There is an `Open Circuit` reversible threshold effect that occurs in Component III due to water polarisation effects that lead to half wave rectification and the appearance of positive unipolar pulses; and

There are electrode polarisation effects in Component II which are a prelude to true electrolysis of water as evidenced by oxygen and hydrogen gas bubble formation.

Appearance of Rippled Square Waves:

Phase 1: At the end of the Stage A dry charging, the output of Component I is lowered to typical values of: $I = 1$ ma. $E = 24V$ AC. f_c .congruent.66,234 Hz.

Phase 2: Then water is added to the Component III water cell drop by drop until the top of the centre electrode, 1', in **Fig.3** is covered, and when this water just makes contact with the inner surface of the top outer electrode at 2'. As this coupling of the two electrodes by water happens, the following series of events occur:

Phase 3: The f_c drops from 66,234 Hz, to a range from 1272 Hz to 1848 Hz. The current and voltage both drop, and begin to pulse in entrainment with the water nuclear spin relaxation constant, $\tau = 3.0$ sec. The presence of

the nuclear spin relaxation oscillation is proven by a characteristic hysteresis loop on the X-Y axes of an oscilloscope.

I = 0 to 0.2 mA surging at .tau. cycle

E = 4.3 to 4.8V AC surging at .tau. cycle

The sine wave carrier converts to a rippled square wave pulse which reflects the RC time constant of water, and it is observed that the square wave contains higher order harmonics. See **Fig.6**:

With the appearance of the rippled square wave, the threshold of hydrolysis may be detected (just barely) as a vapour precipitation on a cover glass slip placed over the Component III cell and viewed under a low power microscope.

The 'Open Circuit' Reversible Threshold Effect:

Phase 4 A secondary effect of the change in the RC constant of water on the wave form shows up as a full half wave rectification of the carrier wave indicating a high level of polarisation of the water molecule in tetrahedral form at the outer electrode.

With the already noted appearance of the rippled square wave, and the signs of faint vapour precipitation which indicate the earliest stage of electrolysis, it is possible to test for the presence of a reversible hydrolysis threshold. This test is carried out by creating an open circuit between Components I and II, i.e., no current flows. This is done by lowering the water level between the two electrodes in the region --- 1' and 2' shown in **Fig.3**; or by interrupting the circuit between Component I and II, while the Component I signal generator is on and oscillating.

Immediately, with the creation of an 'open circuit' condition, the following effects occur:

(a) The carrier frequency, f_c , shifts from Phase 4 valve 1272 Hz to 1848 Hz to 6128 Hz.

(b) The current and voltage drop to zero on the meters which record I and E, but the oscilloscope continues to show the presence of the peak-to-peak (p-p) voltage, and the waveform shows a remarkable effect. The rippled square wave has disappeared, and in its place there appear unipolar (positive) pulses as follows in **Fig.6A**.

The unipolar pulse frequency stabilises to ca. 5000 Hz. The unipolar pulses undergo a 0 to 1.3 volt pulsing amplitude modulation with .tau. at 3.0 seconds. Thus, there exists a pure open circuit reversible threshold for water electrolysis in which the water molecules are capacitor charging and discharging at their characteristic low frequency RC time constant of 0.0002 seconds. It is to be noted that pure water has a very high dielectric constant which makes such an effect possible.

The pulsing amplitude modulation of the voltage is determined by the Hydrogen Nuclear Spin Relaxation constant of 3.0 seconds. It is to be noted that the positive pulse spikes are followed by a negative after-potential. These pulse wave forms are identical to the classic nerve action potential spikes found in the nervous system of all of the living species which have a nervous system. The fact that these unipolar pulses were observed arising in water under the conditions of reversible threshold hydrolysis has a profound significance. These findings illuminate and confirm the Warren McCulloch Theory of water "crystal" dynamics as being the foundation of neural dynamics; and the converse theory of Linus Pauling which holds that water clathrate formation is the mechanism of neural anesthesia.

Phase 5: The effects associated with reversible threshold electrolysis are noted only in passing, since they reflect events which are occurring on the electrode surfaces of Component II, the Thermodynamic Device.

A principal effect which occurs in Stage B, Phase 3, in Component II, (the thermodynamic device), is that the two electrodes undergo stages of polarisation. It has been observed in extensive experiments with different kinds of fluids in the cell of Component II, i.e., distilled water, sea water, tap water, Ringers solution, dilute suspensions of animal and human blood cells, etc. that the inner surface of the outer ring electrode at 3' in **Fig.3** (the electrode that is in contact with the fluid) becomes negatively charged. Referring to **Fig.7**, this corresponds to the left hand columnar area marked, "Electrode .crlbar.".

Electrode Polarisation Effects at the Interface Between Components II and III:

Concurrently with the driver pulsing of Component I at the .tau. constant cycle which leads to electrode polarisation effects in Component II, there is an action on Component III which energises and entrains the water molecule to a higher energy level which shifts the bond angle from 104° to the tetrahedral form with angle $109^\circ 28'$ as shown in **Fig.8** and **Fig.15**.

This electronic pumping action is most important, and represents a significant part of the novel method of this invention for several reasons. First, the shift to the tetrahedral form of water increases the structural stability of the water molecule, thereby making it more susceptible to breakage at the correct resonant frequency, or frequencies. Second, increasing the polarisation of the water molecule makes the lone pair electrons, S- connected with the oxygen molecule more electronegative; and the weakly positive hydrogen atoms, S+ more positive. See **Fig.9** and **Fig.22**.

As the outer electrode becomes more electrically negative, the central electrode becomes more electrically positive as will be shown. As the polarity of the water molecule tetrahedron increases, a repulsive force occurs between the two S+ apices of the water tetrahedron and the negatively charged electrode surface within the region of the Helmholtz layer, as shown in **Fig.7**. This effect "orients" the water molecule in the field, and is the well-known "orientation factor" of electrochemistry which serves to catalyse the rate of oxygen dissociation from the water molecule, and thereby causes the reaction rate to proceed at the lowest energy levels. See **Fig.10** for an example of how the orientation factor works. Near the end of Stage B, the conditions are established for the beginning of the next stage, the stage of high efficiency electrolysis of water.

Stage C:

Generation of the complex wave form frequencies from Component I to match the complex wave form resonant frequencies of the energised and highly polarised water molecule in tetrahedral form with angles, $109^{\circ}28'$ are carried out in Stage C. In the operation of the invention active bubble electrolysis of water is initiated following Stage B, phase 3 by setting (automatically) the output of Component I to:

$I = 1 \text{ mA.}$, $E = 22\text{V AC-rms}$, causing the rippled square wave pulses to disappear with the appearance of a rippled sawtooth wave. The basic frequency of the carrier now becomes, $f_c = 3980 \text{ Hz}$.

The wave form now automatically shifts to a form found to be the prime characteristic necessary for optimum efficiency in the electrolysis of water and illustrated in **Fig.11**. In the wave form of **Fig.11**, the fundamental carrier frequency, $f_c = 3980 \text{ Hz.}$, and a harmonic modulation of the carrier is as follows:

- 1st Order Harmonic Modulation (OHM) = 7960 Hz.
- 2nd Order Harmonic Modulation (II OHM) = 15,920 Hz.
- 3rd Order Harmonic Modulation (III OHM) = 31,840 Hz.
- 4th Order Harmonic Modulation (IV OHM) = 63,690 Hz.

What is believed to be happening in this IV OHM effect is that each of the four apices of the tetrahedron water molecule is resonant to one of the four harmonics observed. It is believed that the combination of negative repulsive forces at the outer electrode with the resonant frequencies just described work together to shatter the water molecule into its component hydrogen and oxygen atoms (as gases). This deduction is based on the following observations of the process through a low power microscope. The hydrogen bubbles were seen to originate at the electrode rim, 4', of **Fig.3**. The bubbles then moved in a very orderly `pearl chain` formation centripetally (like the spokes of a wheel) toward the central electrode, 1' of **Fig.3**, (**Fig.12** shows a top view of this effect).

Thereafter, upon lowering the output of Component I, the threshold for electrolysis of water as evidenced by vapour deposition of water droplets on a glass cover plate over the cell of Component III, is:

$$I = 1 \text{ mA, } E = 10\text{V so, Power} = 10 \text{ mW}$$

with all other conditions and waveforms as described under Stage C, supra. Occasionally, this threshold can be lowered to:

$$I = 1 \text{ ma, } E = 2.6\text{V so, Power} = 2.6 \text{ mW}$$

This Stage C vapour hydrolysis threshold effect cannot be directly observed as taking place in the fluid because no bubbles are formed --- only invisible gas molecules which become visible when they strike a glass plate and combine into water molecules and form droplets which appear as vapour.

Stage D:

Production of hydrogen and oxygen gas at an efficient rate of water electrolysis is slowed in Stage D when a barrier potential is formed, which blocks electrolysis, irrespective of the amount of power applied to Components II and III.

A typical experiment will illustrate the problems of barrier potential formation. Components I, II, and III are set to operate with the following parameters:

$$I = 1 \text{ ma, } E = 11.2\text{V so, Power} = 11.2 \text{ mW (at the start, rising to } 100 \text{ mW later)}$$

This input to Component III yields, by electrolysis of water, approximately 0.1 cm^3 of hydrogen gas per minute at one atmosphere and 289°K . It is observed that as a function of time the f_c crept up from 2978 Hz to 6474 Hz over 27 minutes. The current and the voltage also rose with time. At the 27th minute a barrier effect blocked the electrolysis of water, and one can best appreciate the cycle of events by reference to **Fig.13**.

Stage E:

The Anatomy of the Barrier Effect:

Region A: Shows active and efficient hydrolysis

Region B: The barrier region effect can be initiated with taps of the finger, or it can spontaneously occur as a function of time.

Phase a: The current rose from 1 mA to 30 mA. The voltage fell from 22 volts to 2.5 V.

Phase b: If component II is tapped mechanically during Phase a supra --- it can be reversed as follows: The current dropped from 30 mA to 10 mA. The voltage shot up from 5 volts to over 250 volts (off scale).

Throughout 'Phase a' and 'Phase b', all hydrolysis has ceased. It was observed under the microscope that the inner surface of the outer electrode was thickly covered with hydrogen gas bubbles. It was reasoned that the hydrogen gas bubbles had become trapped in the electrostricted layer, because the water molecule tetrahedrons had flipped so that the S+ hydrogen apices had entered the Helmholtz layer and were absorbed to the electronegative charge of the electrode. This left the S- lone pair apices facing the electrostricted layer. This process bound the newly forming H⁺ ions which blocked the reaction

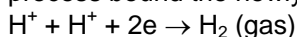

Stage F:

Region C: It was found that the barrier effect could be unblocked by some relatively simple procedures:

(a) Reversing the output electrodes from Component I to Component II, and/or:

(b) Mechanically tapping the Component III cell at a frequency T/2 = 1.5 seconds per tap.

These effects are shown in FIG. 12 and induce the drop in barrier potential from:

$$I = 10 \text{ mA to } 1 \text{ ma, } E = 250V \text{ to } 4V \text{ so, Power fell from } 2.5W \text{ to } 4 \text{ mW}$$

Upon unblocking of the barrier effect, electrolysis of water resumed with renewed bubble formation of hydrogen gas.

The barrier potential problem has been solved for practical application by lowering the high dielectric constant of pure water, by adding salts (NaCl, KOH, etc.) to the pure water thereby increasing its conductivity characteristics. For optimum efficiency the salt concentration need not exceed that of sea water (0.9% salinity) in Section 3, "Thermodynamics of the Invention", it is to be understood that all water solutions described are not "pure" water as in Section B, but refer only to saline water.

Section 3:

The Thermodynamics of the Invention (Saline Water);

Introduction: (water, hereinafter refers to saline water);

The thermodynamic considerations in the normal operations of Components I, II, and III in producing hydrogen as fuel, and oxygen as oxidant during the electrolysis of water, and the combustion of the hydrogen fuel to do work in various heat engines is discussed in this section.

In chemical reactions the participating atoms form new bonds resulting in compounds with different electronic configurations. Chemical reactions which release energy are said to be exergonic and result in products whose chemical bonds have a lower energy content than the reactants. The energy released most frequently appears as heat. Energy, like matter, can neither be created nor destroyed according to the Law of Conservation of Energy. The energy released in a chemical reaction, plus the lower energy state of the products, is equal to the original energy content of the reactants. The burning of hydrogen occurs rather violently to produce water as follows:

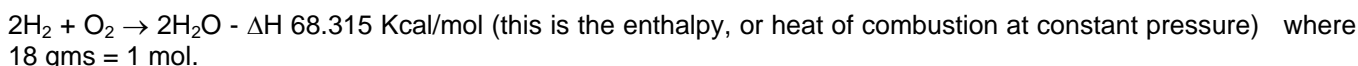

The chemical bonds of the water molecules have a lower energy content than the hydrogen and oxygen gases which serve as the reactants. Low energy molecules are characterised by their stability. High energy molecules are inherently unstable. These relations are summarised in the two graphs of **Fig.14**. It is to be noted that **Fig.14B** shows the endergonic reaction aspect of the invention when water is decomposed by electrolysis into hydrogen and oxygen.

Fig.14A shows the reaction when the hydrogen and oxygen gases combine, liberate energy, and re-form into water. Note that there is a difference in the potential energy of the two reactions. **Fig.14C** shows that there are two components to this potential energy. The net energy released, or the energy that yields net work is labelled in the diagram as "Net Energy Released", and is more properly called the free energy change denoted by the Gibbs function, $-\Delta G$.

The energy which must be supplied for a reaction to achieve (burning) spontaneity is called the "Activation Energy". The sum of the two is the total energy released. A first thermodynamic subtlety of the thermodynamic device of the invention is noted in Angus McDougall's Fuel Cells, Energy Alternative Series, The MacMillan Press Ltd., London, 1976, where on page 15 it is stated:

"The Gibbs function is defined in terms of the enthalpy H, and the entropy S of the system:

$G = H - TS$ (where T is the thermodynamic temperature). A particularly important result is that for an electrochemical cell working reversibly at constant temperature and pressure, the electrical work done is the net work and hence,

$$\Delta G = -w_e$$

For this to be a reversible process, it is necessary for the cell to be on 'open circuit', that is, no current flows and the potential difference across the electrodes is the EMF, E. Thus,

$$\Delta G = -zFE$$

(where F is the Faraday constant --- the product of the Avogadro Constant + $N_A = 6.022045 \times 10^{23}$ mole⁻¹, and the charge on the electron, $e = 1.602189 \times 10^{-19}$ C --- both in SI units; and z is the number of electrons transported.) when the cell reaction proceeds from left to right."

It is to be noted that the Activation Energy is directly related to the controlling reaction rate process, and thus is related to the Gibbs free energy changes. The other thermodynamic subtlety is described by S. S. Penner in his work: Penner, S. S. and L. Icerman, Energy, Vol, II, Non-Nuclear Energy Technologies. Addison-Wesley Publishing Company, Inc. Revised Edition, 1977. Reading, Mass. where on page 140 it is stated that:

"It should be possible to improve the efficiency achieved in practical electrolysis to about 100% because, under optimal operating conditions, the theoretically-attainable energy conversion by electrolysis is about 120% of the electrical energy input. The physical basis for this last statement will now be considered:

"A useful definition for energy efficiency in electrolysis is the following: the energy efficiency is the ratio of the energy released from the electrolysis products formed (when they are subsequently used) to the energy required to effect electrolysis. The energy released by the process

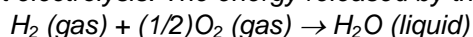

under standard conditions (standard conditions in this example are: (1) atmospheric pressure = 760 mm Hg and (2) temperature = 298.16°K. = 25°C. = 77°F.) is 68.315 Kcal and is numerically equal to the enthalph change (ΔH) for the indicated process. On the other hand, the minimum energy (or useful work input) required at constant temperature and pressure for electrolysis equals the Gibbs free energy change (ΔG). There is a basic relation derivable from the first and second laws of thermodynamics for isothermal changes, which shows that:

$$\Delta G = \Delta H - T \Delta S$$

where ΔS represents the entropy change for the chemical reaction. The Gibbs free energy change (ΔG) is also related to the voltage (E) required to implement electrolysis by Faraday's equation, viz.

$$E = (\Delta G / 23.06n) \text{ volts}$$

where ΔG is in Kcal/mol and n is the number of electrons (or equivalents) per mol of water electrolysed and has the numerical value 2.

At atmospheric pressure and 300°K., $\Delta H = 68.315$ Kcal/mol of H_2O (l) and $\Delta G = 56.62$ Kcal/mole of H_2O (l) for the electrolysis of liquid water. Hence, the energy efficiency of electrolysis at 300°K. is about 120%.

(When) H_2 (gas) and O_2 (gas) are generated by electrolysis, the electrolysis cell must absorb heat from the surroundings, in order to remain at constant temperature. It is this ability to produce gaseous electrolysis products with heat absorption from the surroundings that is ultimately responsible for energy-conversion efficiencies during electrolysis greater than unity."

Using the criteria of these two authorities, it is possible to make a rough calculation of the efficiency of the present invention.

Section 4:

Thermodynamic Efficiency of the Invention;

Efficiency is deduced on the grounds of scientific accounting principles which are based on accurate measurements of total energy input to a system (debit), and accurate measurements of total energy (or work) obtained out of the system (credit). In principle, this is followed by drawing up a balance sheet of energy debits and credits, and expressing them as an efficiency ration, ϵ .

$$\eta = \frac{\text{Credit}}{\text{Debit}} = \frac{\text{Energy Out}}{\text{Energy In}} < 1$$

The energy output of Component I is an alternating current passing into a highly non-linear load, i.e., the water solution. This alternating current generator (Component I) is so designed that at peak load it is in resonance (Components I, II, III), and the vector diagrams show that the capacitive reactance, and the inductive reactance are almost exactly 180° out of phase, so that the net power output is reactive, and the dissipative power is very small. This design insures minimum power losses across the entire output system. In the experiments which are now to be described the entire emphasis was placed on achieving the maximum gas yield (credit) in exchange for the minimum applied energy (debit).

The most precise way to measure the applied energy to Components II and III is to measure the Power, P, in Watts, W. This was done by precision measurements of the volts across Component II as root mean square (rms) volts; and the current flowing in the system as rms amperes. Precisely calibrated instruments were used to take these two measurements. A typical set of experiments (using water in the form of 0.9% saline solution = 0.1540 molar concentration) to obtain high efficiency hydrolysis gave the following results:

rms Current = 25 mA to 38 mA (0.025 A to 0.038 A)

rms Volts = 4 Volts to 2.6 Volts

The resultant ratio between current and voltage is dependent on many factors, such as the gap distance between the central and ring electrodes, dielectric properties of the water, conductivity properties of the water, equilibrium states, isothermal conditions, materials used, and even the presence of clathrates. The above current and voltage values reflect the net effect of various combinations of such parameters. The product of rms current, and rms volts is a measure of the power, P in watts:

$$P = I \times E = 25 \text{ mA} \times 4.0 \text{ volts} = 100 \text{ mW (0.1 W)}$$

$$P = I \times E = 38 \text{ mA} \times 2.6 \text{ volts} = 98.8 \text{ mW (0.0988 W)}$$

At these power levels (with load), the resonant frequency of the system is 600 Hz (plus or minus 5 Hz) as measured on a precision frequency counter. The wave form was monitored for harmonic content on an oscilloscope, and the nuclear magnetic relaxation cycle was monitored on an X-Y plotting oscilloscope in order to maintain the proper hysteresis loop figure. All experiments were run so that the power in Watts, applied through Components I, II, and III ranged between 98.8 mW to 100 mW. Since, by the International System of Units --- 1971 (SI), One-Watt-second (Ws) is exactly equal to One Joule (J), the measurements of efficiency used these two yardsticks (1 Ws = 1 J) for the debit side of the measurement.

The energy output of the system is, of course, the two gases, hydrogen (H₂) and oxygen (1/2O₂), and this credit side was measured in two laboratories, on two kinds of calibrated instruments, namely, a Gas Chromatography Machine, and, a Mass Spectrometer Machine.

The volume of gases, H₂ and (1/2)O₂, was measured as produced under standard conditions of temperature and pressure in unit time, i.e., in ccs per minute (cc/min), as well as the possibly contaminating gases, such as air oxygen, nitrogen and argon; carbon monoxide, carbon dioxide, water vapour, etc.

The electrical, and gas, measurements were reduced to the common denominator of Joules of energy so that the efficiency accounting could all be handled in common units. The averaged results from many experiments follow. The Standard Error between different samples, machines, and locations is plus or minus 10%, and only the mean was used for all the following calculations.

Section 5:

Endergonic Decomposition of Liquid Water;

Thermodynamic efficiency for the endergonic decomposition of saline liquid water into gases under standard atmosphere (754 to 750 m.m. Hg), and standard isothermal conditions @ 25°C. = 77°F. = 298.16°K., according to the following reaction:

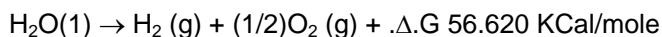

As already described, Δ.G is the Gibbs function (**Fig.14B**). A conversion of Kcal to the common units, Joules, by the formula, One Calorie = 4.1868 Joules was made.

$$\Delta.G = 56.620 \text{ Kcal} \times 4.1868 \text{ J} = 236,954 \text{ J/mol of H}_2\text{O (1) where, 1 mole is 18 gms.}$$

Δ.G = the free energy required to yield an equivalent amount of energy from H₂O in the form of the gases, H₂ and (1/2)O₂.

To simplify the calculations, the energy required to produce 1.0 cc of H₂O as the gases, H₂ and (1/2)O₂ was determined. There are (under standard conditions) 22,400 cc = V, of gas in one mole of H₂O. Therefore:

$$\frac{\Delta G}{V} = \frac{236,954 \text{ J}}{22,400 \text{ cc}} = 10.5783 \text{ J/cc}$$

The electrical energy required to liberate 1.0 cc of the H₂O gases (where H₂ = 0.666 parts, and (1/2)O₂ = 0.333 parts, by volume) from liquid water is then determined. Since P = 1 Ws = 1 Joule, and V=1.0 cc of gas = 10.5783 Joules, then:

$$PV = 1 \times 10.5783 \text{ J} = 10.5783 \text{ Ws}$$

Since the experiments were run at 100 mW (0.1 W) applied to the water sample in Component II, III, for 30 minutes, the ideal (100% efficient) gas production at this total applied power level was calculated.

$$0.1 \text{ Ws} \times 60 \text{ sec} \times 30 \text{ min} = 180.00 \text{ Joules (for 30 min)}$$

The total gas production at Ideal 100% efficiency is,

$$180.00 \text{ J} / 10.5783 \text{ J/cc} = 17.01 \text{ cc H}_2\text{O (g)}$$

The amount of hydrogen present in the 17.01 cc H₂O (g) was then calculated.

$$17.01 \text{ cc H}_2\text{O (gas)} \times 0.666 \text{ H}_2 \text{ (g)} = 11.329 \text{ cc H}_2 \text{ (g)}$$

$$17.01 \text{ cc H}_2\text{O (g)} \times 0.333 \text{ (1/2)O}_2 \text{ (g)} = 5.681 \text{ cc (1/2)O}_2 \text{ (g)}$$

Against this ideal standard of efficiency of expected gas production, the actual amount of gas produced was measured under: (1) standard conditions as defined above (2) 0.1 Ws power applied over 30 minutes. In the experiments, the mean amount of H₂ and (1/2)O₂ produced, as measured on precision calibrated GC, and MS machines in two different laboratories, where the S.E. is +/-10%, was,

$$\text{Measured Mean} = 10.80 \text{ cc H}_2 \text{ (g)}$$

$$\text{Measured Mean} = 5.40 \text{ cc (1/2)O}_2 \text{ (g)}$$

$$\text{Total Mean} = 16.20 \text{ cc H}_2\text{O(g)}$$

The ratio, ϵ , between the ideal yield, and measured yield is:

$$\eta = \frac{\text{Measured H}_2\text{(g)}}{\text{Ideal H}_2\text{(g)}} = \frac{10.80 \text{ cc}}{11.33 \text{ cc}} = 91.30\%$$

Section 6:

Energy Release;

The total energy release (as heat, or electricity) from an exergonic reaction of the gases, H₂ and O₂, is given by:

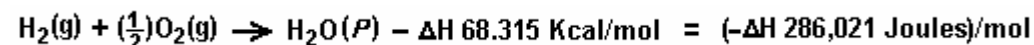

It is possible (Penner, Op. Cit., p.128) to get a total heat release, or total conversion to electricity in a fuel cell, in the above reaction when the reactants are initially near room temperature (298.16°K.), and the reactant product (H₂O) is finally returned to room temperature. With this authoritative opinion in mind, it is desirable to determine the amount of energy released (ideal) from the exergonic experiment. The total energy of 1.0 cc of H₂O (1), as above is:

$$1.0 \text{ cc } \Delta H = \frac{286,021 \text{ J/mol}}{22,400 \text{ cc/mol}} = 12.7687 \text{ J/cc H}_2\text{O}$$

for H₂ = 12.7687 x 0.666 = 8.509 J/0.66 cc H₂ for O₂ = 12.7687 x 0.333 = 4.259 J/0.33 cc (1/2)O₂ The energy produced from the gases produced in the experiments in an exergonic reaction was:

$$16.20 \text{ cc H}_2\text{O (g)} \times 12.7687 \text{ J/cc H}_2\text{O} = 206,8544 \text{ J.}$$

The overall energy transaction can be written as:

$$\frac{\text{EXERGONIC}}{\text{ENDERGONIC}} - \eta = \frac{-\Delta H}{+\Delta G} = \frac{206,854.4 \text{ J}}{180,000 \text{ J}} = 114.92\%$$

In practical bookkeeping terms the balance of debits and credits, n = (-.Δ.H) - (+.Δ.G), so:

$$n = 206.8544 \text{ J} - 180.0 = + 26.8544 \text{ J (surplus).}$$

Since, in the invention, the gas is produced where and when needed, there is no additional cost accounting for liquefaction, storage, or transportation of the hydrogen fuel, and the oxygen oxidant. Therefore, the practical efficiency, is:

$$\eta_P = \frac{26.8544 \text{ J}}{180.0000 \text{ J}} = 14.919\% \text{ (as net return on the original energy investment)}$$

In practical applications, the energy output (exergonic) of the Component II System can be parsed between the electrical energy required to power the Component I System, as an isothermal closed loop; while the surplus of approximately 15% can be shunted to an engine (heat, electrical, battery, etc.) that has a work load. Although this energy cost accounting represents an ideal model, it is believed that there is enough return (approximately 15%) on the capital energy investment to yield a net energy profit that can be used to do useful work.

CONCLUSION:

From the foregoing disclosure it will be appreciated that the achievement of efficient water splitting through the application of complex electrical waveforms to energised water molecules, i.e. tetrahedral molecules having bonding angles of $109^{\circ}28'$, in the special apparatus described and illustrated, will provide ample and economical production of hydrogen gas and oxygen gas from readily available sources of water. It is to be understood, that the specific forms of the invention disclosed and discussed herein are intended to be representative and by way of illustrative example only, since various changes may be made therein without departing from the clear and specific teachings of the disclosure. Accordingly, reference should be made to the following appended claims in determining the full scope of the method and apparatus of the present invention.

APPARATUS FOR DECOMPOSITION OF AQUEOUS LIQUID

Please note that this is a re-worded excerpt from this patent. This patent describes an electrolysis system which it is claimed has demonstrated ten times the efficiency that Faraday considered to be the maximum possible.

ABSTRACT

An apparatus for decomposition of liquid, in which spiral negative and positive electrodes are arranged close together but not touching. These two electrodes are supplied with power through external terminals and the electrolyte is caused to flow between the negative and positive electrodes for the electrolysis between two electrodes under the function of the potential magnetic field formed by the coil current which is generated by the electrodes with active movement of an electrolytic ion so that the electrolysis of water takes place smoothly under the spin functions of the atom and electron.

BACKGROUND AND SUMMARY OF THE INVENTION

This invention relates to an apparatus for decomposition of liquid where a flowing electrolyte is subjected to electrolysis for the production of gases.

As is well known, water is composed of hydrogen atoms and oxygen atoms. When water is sufficiently magnetised, each constitutive atom is also weakly magnetised to rotate the elementary particle in a regular direction. This rotation of the elementary particle is generally called "spin". That is, the spin function is caused by an electron, atomic nucleus, atom and even by the molecule. When a negative electrode is immersed in the electrolyte - Sodium Hydroxide ("lye") solution - with a view to applying a voltage to it in order to cause the elementary particle to react with the electric field, the coupling state of the hydrogen with the oxygen is varied and the electrolysis is facilitated by the spin.

In the present invention, spiral negative and positive electrodes are arranged close together but not touching and these two electrodes are supplied with power through external terminals and the electrolyte is caused to flow between the negative and positive electrodes. Thus, the electrolyte is subjected to the electrolysis between two electrodes while within a magnetic field formed by the coil current which is generated by the electrodes with active movement of an electrolytic ion (Na^+ , OH^-) so that the electrolysis of water takes place smoothly under the spin functions of the atom and electron.

It has been confirmed that the rate of the electrolysis of water using this invention is approximately 10 or more times (approximately 20 times when calculated) than that produced by conventional electrolysis.

The design of the electrolytic cell of this invention is such that the electrolyte flowing through the supply ports provided at the lower portion of the electrolytic cell is subjected to the magnetic field produced by a permanent magnet and the electrodes cause it to be further subjected to magnetic and electric fields which cause it to obtain a sufficient spin effect.

It is, therefore, a general object of the invention to provide a novel apparatus for decomposition of liquid in which an electrolyte (NaOH) solution is subjected to magnetic fields to cause electrolysis assisted by the spin of the water molecules which produces a great amount of gas with less consumption of electrical energy.

A principal object of the invention is to provide an apparatus for decomposition of liquid which has a liquid circulating system for the separation of gas and liquid in which positive and negative spiral electrodes are arranged across the flow path of the liquid and the opposite ends of the electrodes being provided with magnetic materials to augment the effect caused by the applied voltage across a liquid passing through a magnetic field caused by the positive and negative spiral electrodes, thereby to promote generation and separation of cat-ions and an-ions with a high efficiency in production of a large quantity of gases.

Other objects and advantages of the present invention will become apparent through the detailed description which follows.

BRIEF DESCRIPTION OF THE DRAWINGS

The invention will be described more in detail in the following with reference to the accompanying drawings, wherein:

Fig.1 is a partially cross-sectional schematic elevation of an apparatus in accordance with the invention;

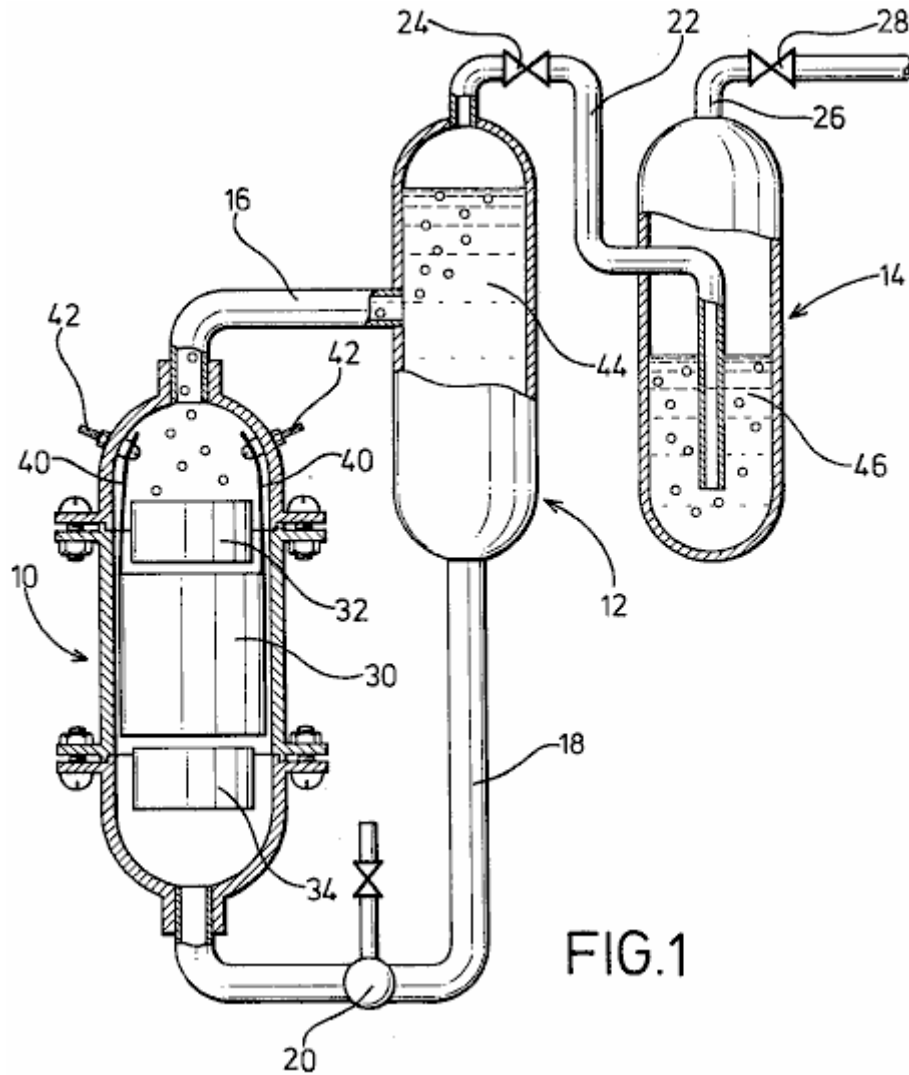

Fig.2 is a perspective view of electrodes arranged in accordance with the invention;

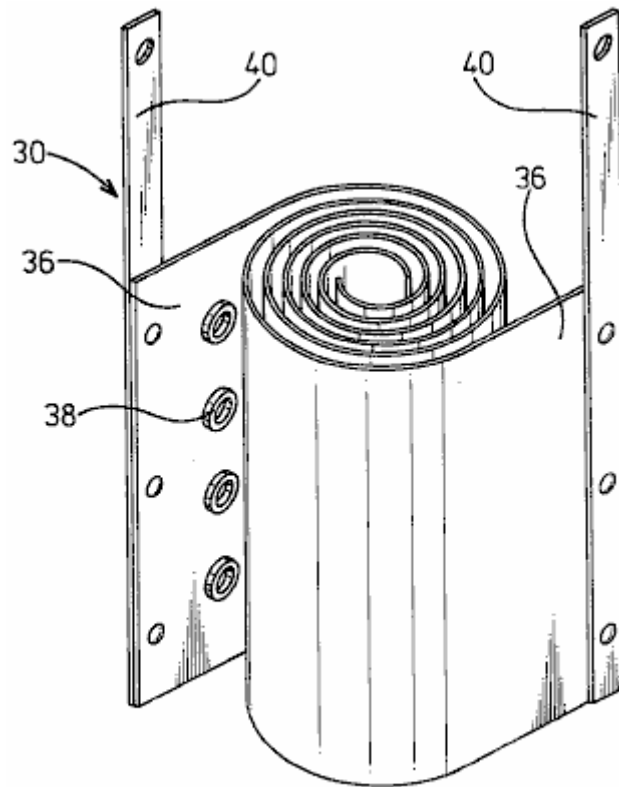

FIG.2

Fig.3 is a plan view of electrodes with magnetic materials.

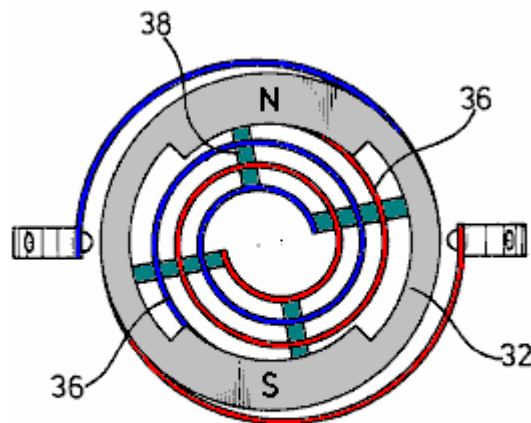

FIG.3

DESCRIPTION OF THE PREFERRED EMBODIMENT

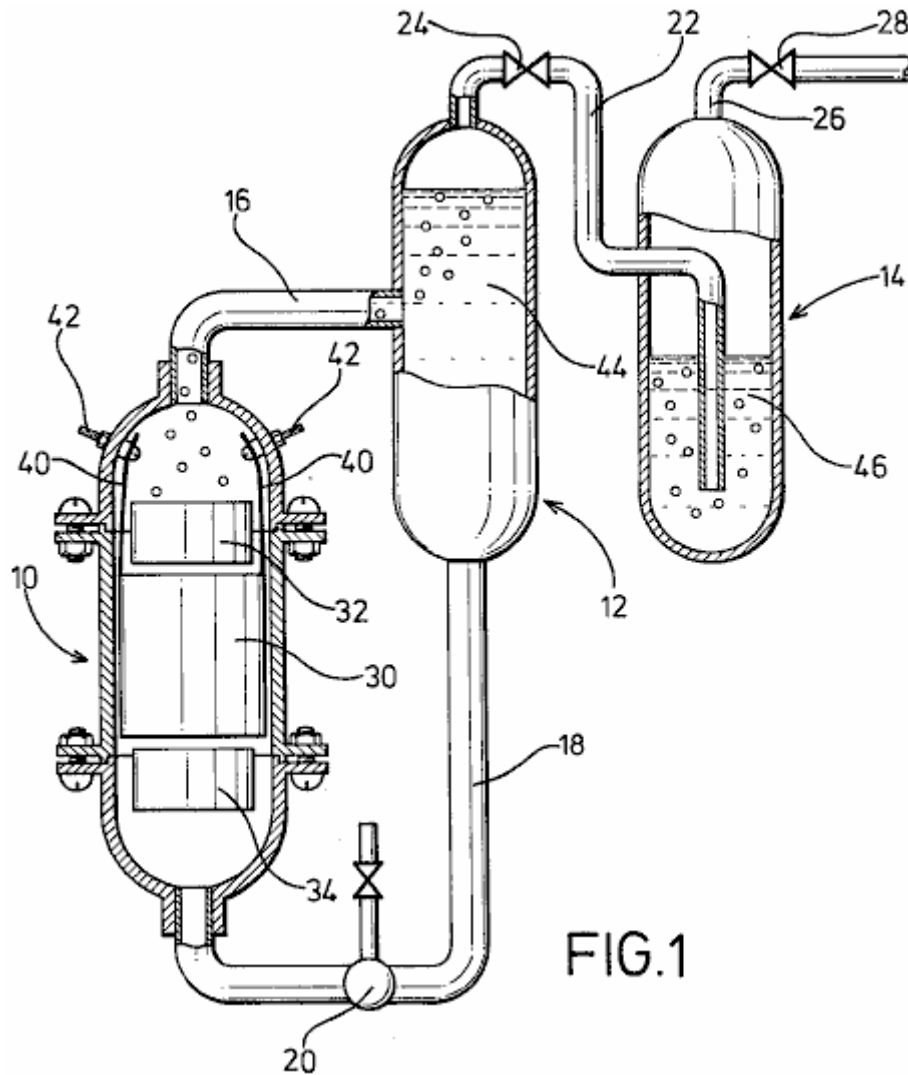

FIG.1

In **Fig.1**, an electrolysis cell **10**, a gas-liquid separation tank **12** and a gas-washing tank **14** are vertically arranged as shown with the electrolytic cell **10** being positioned a little lower than the tanks.

Cell **10** and tanks **12** and **14** are connected together by a delivery pipe **16** which connects the top of the electrolytic cell **10** with the middle of the gas-liquid separation tank **12**. A feed-back pipe **18** containing a pump **20**, is provided to connect the bottom of the gas-liquid separation tank **12**, with the bottom of the electrolytic cell **10**. Also provided is pipe **22**, which runs from the top of the gas-liquid separation tank **12** through a valve **24** to the bottom of the gas-washing tank **14**. A drain pipe **26**, provided with a valve **28**, is taken from the top of the gas-washing tank **14**.

In the electrolytic cell **10**, positive and negative spiral electrodes **30** of diameters suited to the internal diameter of the electrolytic cell **10** are arranged coaxially. At the upper and lower parts of the spiral electrodes **30** are arranged magnet rings **32** and **34** made from ferrite or similar material, positioned so that North and South poles are opposite one another to create a magnetic field which is at right angles to the axis of the electrolytic cell.

Electrodes **30** are composed of two metal strips **36** which are wound into spiral shapes with cylindrical insulating spacers **38** made of rubber or a similar material, placed between them and attached to the surface of the metal strips **36**. From the metal strips **36**, wires **40**, are taken to the positive and negative power supply terminals, via connectors provided in the inner wall of the electrolytic cell.

The electrolytic cell **10** and the gas-liquid separation tank **12** are filled with a electrolyte **44** which is circulated by the pump **20**, while the gas-washing tank **14** is filled with a washing liquid **46** to such a level that gases gushing out of the conduit **22** are thoroughly washed.

The apparatus of the present invention may be well be used for the electrolysis of flowing water for the production of hydrogen gas and oxygen gas at a high efficiency. That is to say, the electrolytic cell **10** and the gas-liquid separation tank **12** are filled with the electrolyte **44** which is caused by pump **20** to flow through a magnetic field in an vortex path in which positive and negative magnetic poles N, S of the magnets **32** and **34** face each other to

produce a transverse field, and through the metal plates **36** of the vortical electrodes **30** to generate an orientation for the electrical migration of cat-ions and an-ions, causing an increased gas separation rate and enhancement of the electrolysis.

In particular, the flowing oxygen gas serves to facilitate an aeration of the electrolyte since it has varying magnetic effects as it passes through the magnetic field. The spiral electrodes **30** of this invention, create a remarkable increase in the rate of electrolysis. This is caused by the continuously decreasing space between the electrodes **30** which causes the flow velocity to increase as the flow progresses along its path. This causes turbulence which instantly removes bubbles of gas from the surface of the electrodes, allowing fresh ions full contact with the metal surfaces, thus raising the efficiency of the cell.

The spiral coiling of the electrodes also enables a very desirable reduction in the size of the cell, while increasing the electrode area and improving its contact with the electrolyte **44**. There is also a relatively short migration distance of ions which also promotes rapid gas production. On the other hand, insulating spacers **38** interposed between the metal strips **36** serves to create the desired turbulence of the electrolyte passing through the cell.

The liquid circulating system for separation of gas and liquid requires no other driving unit except the circulation pump **20** to achieve separation of gas and liquid by utilising differences in water heads between cell **10** and tanks **12** and **14**. In other words, a flow of gas-liquid mixture supplied from electrolytic cell **10** is fed into the gas-liquid separation tank **12** where, due to the difference in buoyancy of gases and liquid, the gas rises and is fed into the gas-washing tank **14** while the liquid moves down and is returned to the electrolytic cell **10**. The washing tank **14** is filled with any convenient washing liquid **46** so that the gases gushing out of conduit **22** are thoroughly washed and fed into the drain pipe **26**. Thus, the apparatus may be constructed at reduced cost and without any complexity.

As described earlier, the magnets **32** and **34** provide positive and negative magnetic poles N, S which are confronted in the annular wall for facilitating an alignment between the cross section of the flow-path of the liquid and the annular portion of the magnets **32** and **34** and a generation of a magnetic field in a direction perpendicular to that of the liquid flow, so that the liquid is forced to flow through the magnetic field.

Experimental data	Value
Room temperature	20 ⁰ Centigrade
Atmospheric pressure	1003 millibars
Electrolyte temperature	25 ⁰ Centigrade
Humidity	43%
Voltage	2.8 Volts
Current	30 Amps
Hydroxy gas production rate	116 cc/sec.
Hydrogen production per Coulomb (1A x 1 sec.)	2.6 cc.
Oxygen production per Coulomb	1.3 cc.

The rate of generation shown by these figures is over 20 times that which could be obtained by standard Faraday electrolysis.

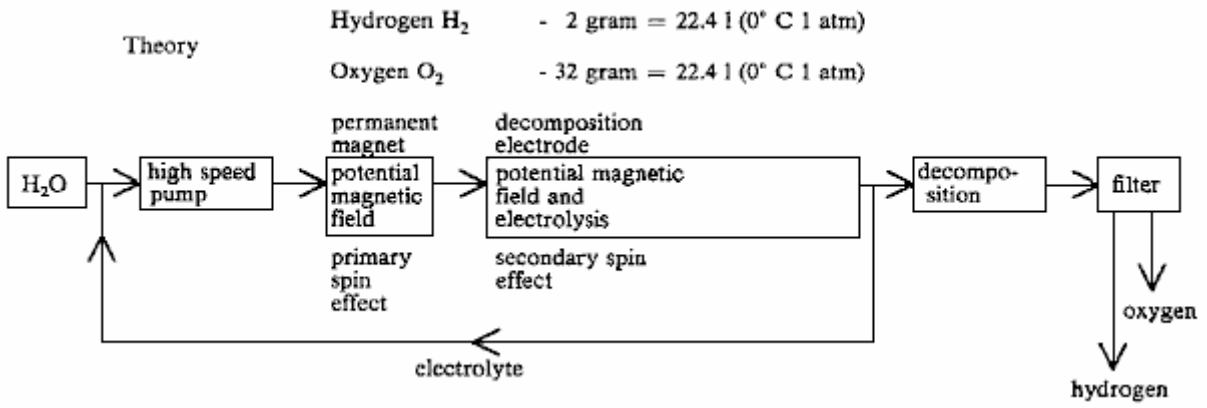

While a preferred embodiment of the invention has been illustrated by way of example in the drawings and particularly described, it will be understood that various modifications may be made in the construction and that the invention is no way limited to the embodiments shown.

AN APPARATUS FOR PRODUCING ORTHOHYDROGEN AND/OR PARAHYDROGEN

This patent describes an electrolyser system capable of running a small internal combustion engine directly from water alone.

ABSTRACT

An apparatus for producing orthohydrogen and/or parahydrogen. The apparatus includes a container holding water and at least one pair of closely-spaced electrodes arranged within the container and submerged in the water. A first power supply provides a particular first pulsed signal to the electrodes. A coil may also be arranged within the container and submerged in the water if the production of parahydrogen is also required. A second power supply provides a second pulsed signal to the coil through a switch to apply energy to the water. When the second power supply is disconnected from the coil by the switch and only the electrodes receive a pulsed signal, then orthohydrogen can be produced. When the second power supply is connected to the coil and both the electrodes and coil receive pulsed signals, then the first and second pulsed signals can be controlled to produce parahydrogen. The container is self-pressurised and the water within the container requires no chemical catalyst and yet can produce the orthohydrogen and/or parahydrogen efficiently. Heat is not generated, and bubbles do not form on the electrodes.

BACKGROUND OF THE INVENTION

Conventional electrolysis cells are capable of producing hydrogen and oxygen from water. These conventional cells generally include two electrodes arranged within the cell which apply energy to the water to thereby produce hydrogen and oxygen. The two electrodes are conventionally made of two different materials.

However, the hydrogen and oxygen generated in the conventional cells are generally produced in an inefficient manner. That is, a large amount of electrical power has to be applied to the electrodes in order to produce the hydrogen and oxygen. Moreover, a chemical catalyst such as sodium hydroxide or potassium hydroxide must be added to the water to separate hydrogen or oxygen bubbles from the electrodes. Also, the produced gas must often be transported to a pressurised container for storage, because conventional cells produce the gases slowly. Also, conventional cells tend to heat up, creating a variety of problems, including boiling of the water. In addition, conventional cells tend to form gas bubbles on the electrodes which act as electrical insulators and reduce the efficiency of the cell.

Accordingly, it is extremely desirable to produce a large amount of hydrogen and oxygen with only a modest amount of input power. Furthermore, it is desirable to produce the hydrogen and oxygen with "regular" tap water and without any additional chemical catalyst, and to operate the cell without the need for an additional pump to pressurise it. It is also desirable to construct both of the electrodes from the same material. It is also desirable to produce the gases quickly, and without heat, and without bubbles forming on the electrodes.

Orthohydrogen and parahydrogen are two different isomers of hydrogen. Orthohydrogen is that state of hydrogen molecules in which the spins of the two nuclei are parallel. Parahydrogen is that state of hydrogen molecules in which the spins of the two nuclei are antiparallel. The different characteristics of orthohydrogen and parahydrogen lead to different physical properties. For example, orthohydrogen is highly combustible whereas parahydrogen is a slower burning form of hydrogen. Thus, orthohydrogen and parahydrogen can be used for different applications. Conventional electrolytic cells make only orthohydrogen and parahydrogen. Parahydrogen is difficult and expensive to make by conventional means.

Accordingly, it is desirable to produce orthohydrogen and/or parahydrogen cheaply within a cell and to be able to control the amount of either produced by that cell. It is also desirable to direct the produced orthohydrogen or parahydrogen to a coupled machine in order to provide a source of energy for it.

SUMMARY OF THE INVENTION

It is therefore an object of the present invention to provide a cell having electrodes and containing water which produces a large amount of hydrogen and oxygen in a relatively small amount of time, and with a modest amount of input power, and without generating heat.

It is another object of the present invention for the cell to produce bubbles of hydrogen and oxygen which do not bunch around or on the electrodes.

It is also an object of the present invention for the cell to operate properly without a chemical catalyst. Thus, the cell can be run using ordinary tap water. This has the advantage of avoiding the additional costs required for producing the chemical catalyst.

It is another object of the present invention for the cell to be self-pressurising. Thus avoiding the need for an additional pump.

It is another object of the present invention to provide a cell having electrodes made of the same material. This material can, for example, be stainless steel. Thus, the construction of the cell can be simplified and construction costs reduced.

It is another object of the present invention to provide a cell which is capable of producing orthohydrogen, parahydrogen or a mixture thereof and can be set so as to produce any relative amount of orthohydrogen and parahydrogen desired by the user.

It is another object of the invention to couple the gaseous output of the cell to a device, such as an internal combustion engine, so that the device may be powered from the gas supplied to it.

These and other objects, features, and characteristics of the present invention will be more apparent upon consideration of the following detailed description and appended claims with reference to the accompanying drawings, wherein the same reference numbers have been used to indicate corresponding parts in the various figures.

Accordingly, the present invention includes a container for holding water. At least one pair of closely-spaced electrodes are positioned within the container and submerged under the water. A first power supply provides a particular pulsed signal to the electrodes. A coil is also arranged in the container and submerged under the water. A second power supply provides a particular pulsed signal through a switch to the electrodes.

When only the electrodes receive a pulsed signal, then orthohydrogen can be produced. When both the electrodes and coil receive pulsed signals, then parahydrogen or a mixture of parahydrogen and orthohydrogen can be produced. The container is self pressurised and the water within the container requires no chemical catalyst to produce the orthohydrogen and/or parahydrogen efficiently.

BRIEF DESCRIPTION OF THE DRAWINGS

Fig.1 is a side view of a cell for producing orthohydrogen including a pair of electrodes according to a first embodiment of the present invention;

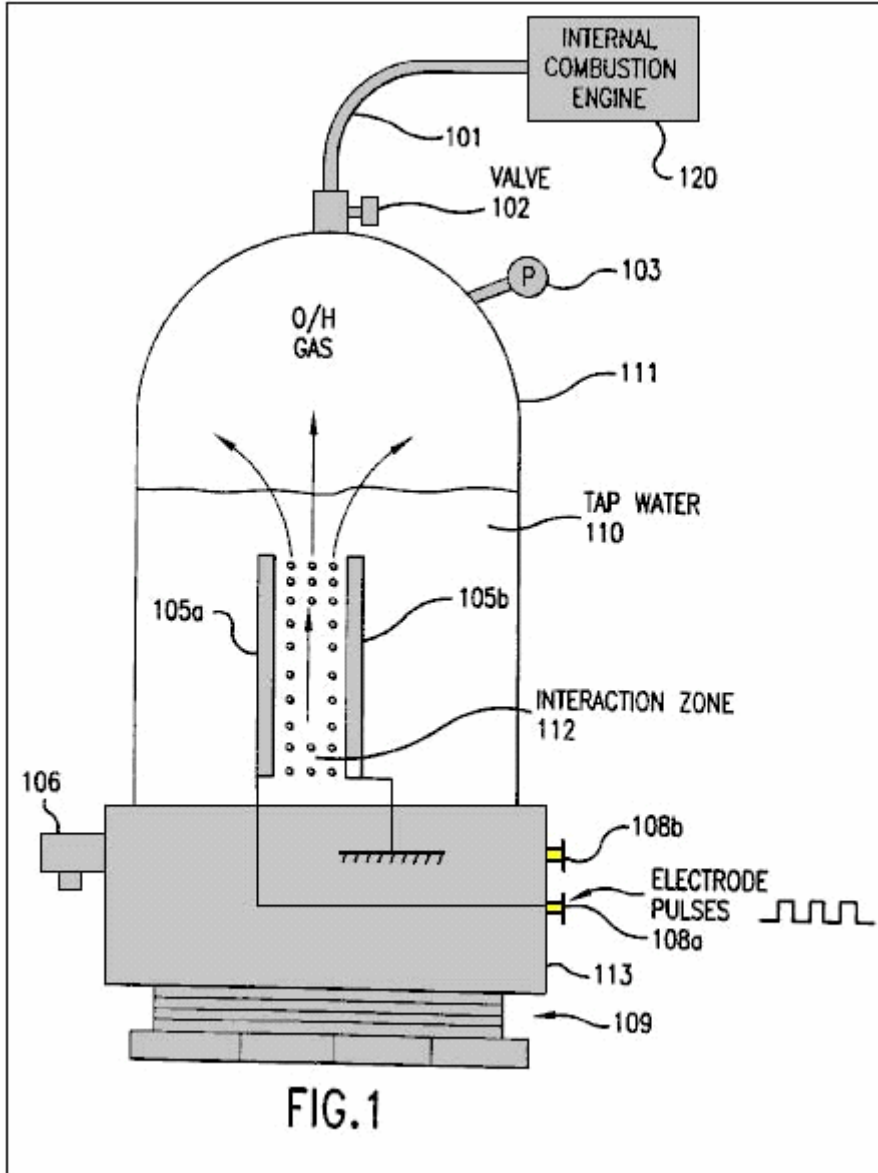

Fig.2 is a side view of a cell for producing orthohydrogen including two pairs of electrodes according to a second embodiment of the present invention;

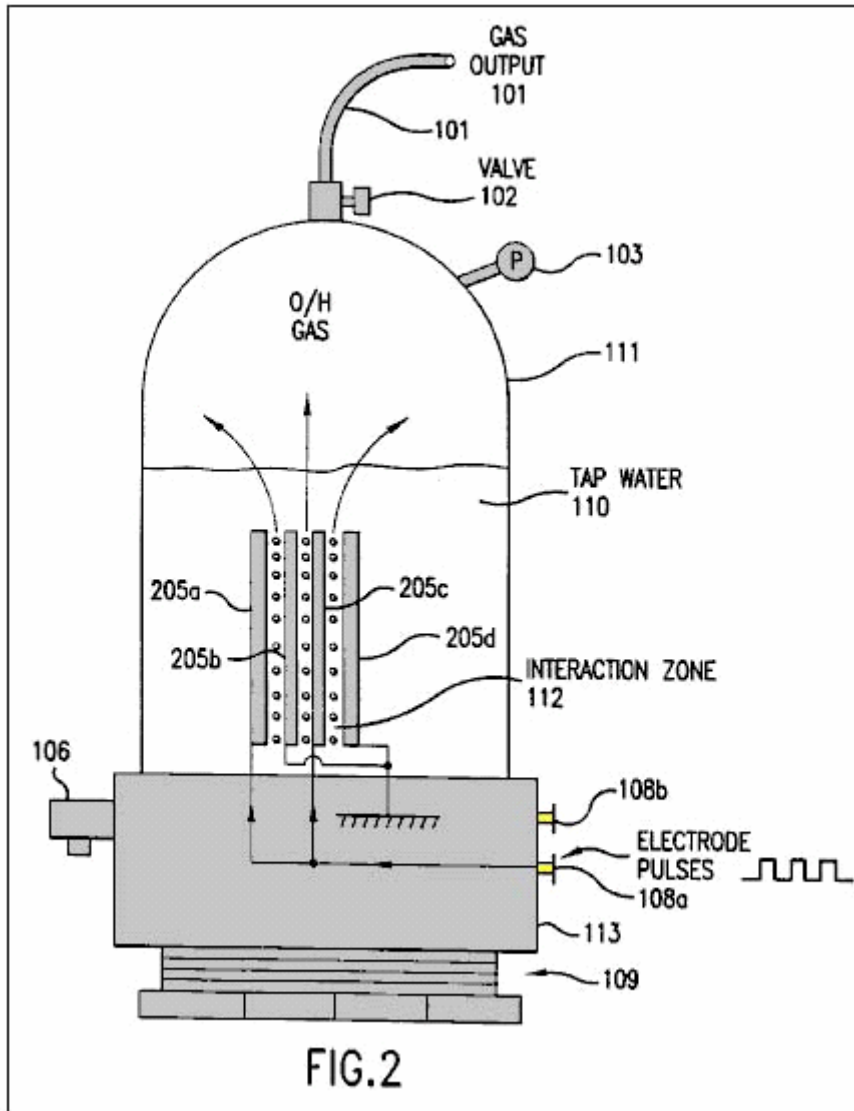

Fig.3 is a side view of a cell for producing orthohydrogen including a pair of cylindrical-shaped electrodes according to a third embodiment of the present invention;

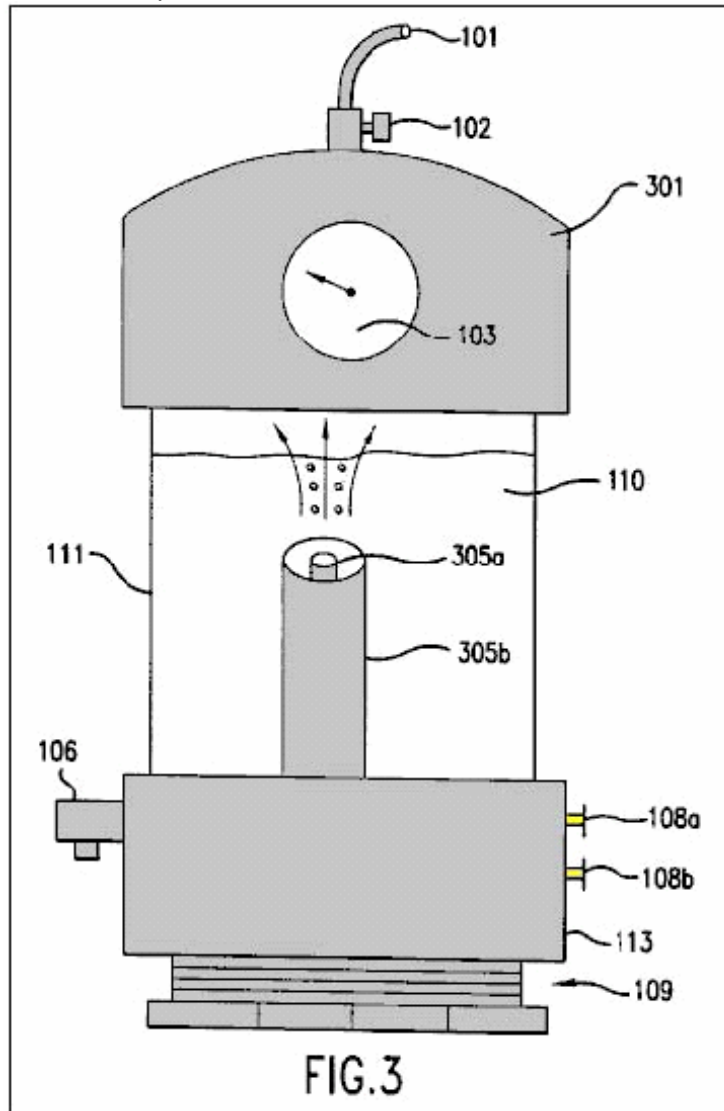

Fig.4a is a diagram illustrating a square wave pulsed signal which can be produced by the circuit of **Fig.5** and applied to the electrodes of **Fig.1** through **Fig.3**;

Fig.4b is a diagram illustrating a saw tooth wave pulsed signal which can be produced by the circuit of **Fig.5** and applied to the electrodes of **Fig.1** through **Fig.3**;

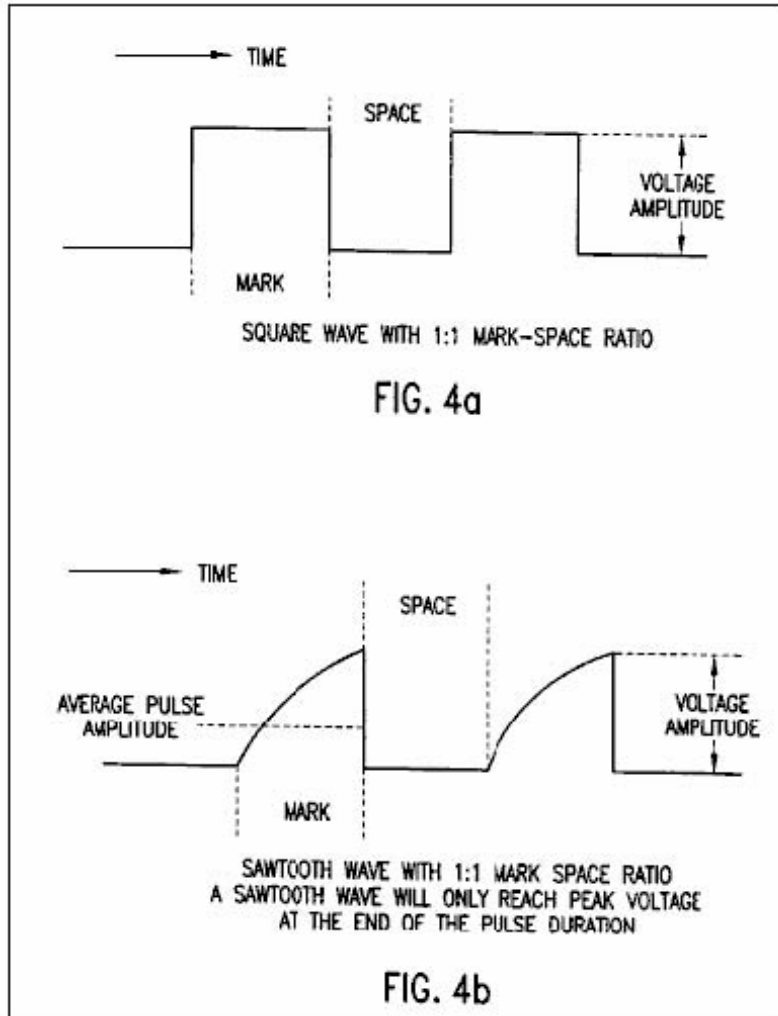

Fig.4c is a diagram illustrating a triangular wave pulsed signal which can be produced by the circuit of **Fig.5** and applied to the electrodes of **Fig.1** through **Fig.3**;

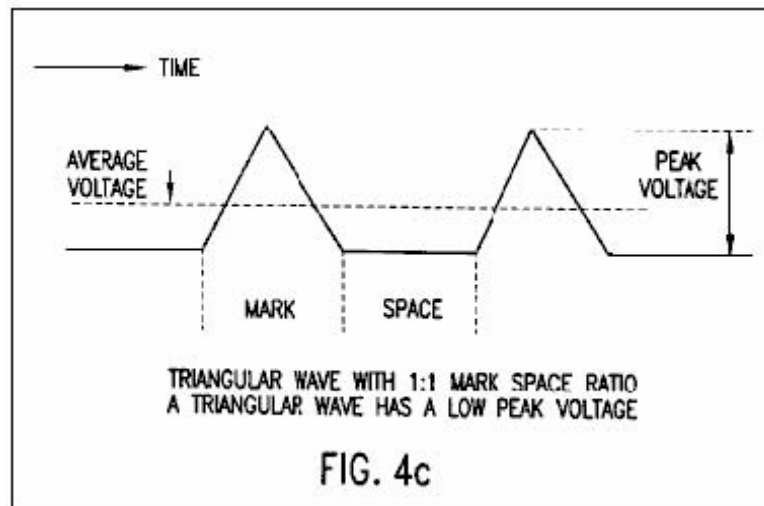

Fig.5 is an electronic circuit diagram illustrating a power supply which is connected to the electrodes of **Fig.1** through **Fig.3**;

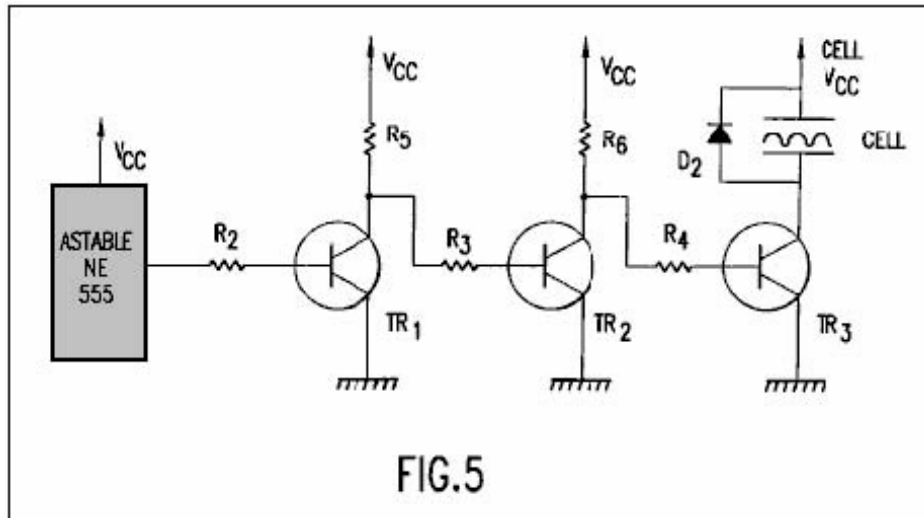

Fig.6 is a side view of a cell for producing at least parahydrogen including a coil and a pair of electrodes according to a fourth embodiment of the present invention;

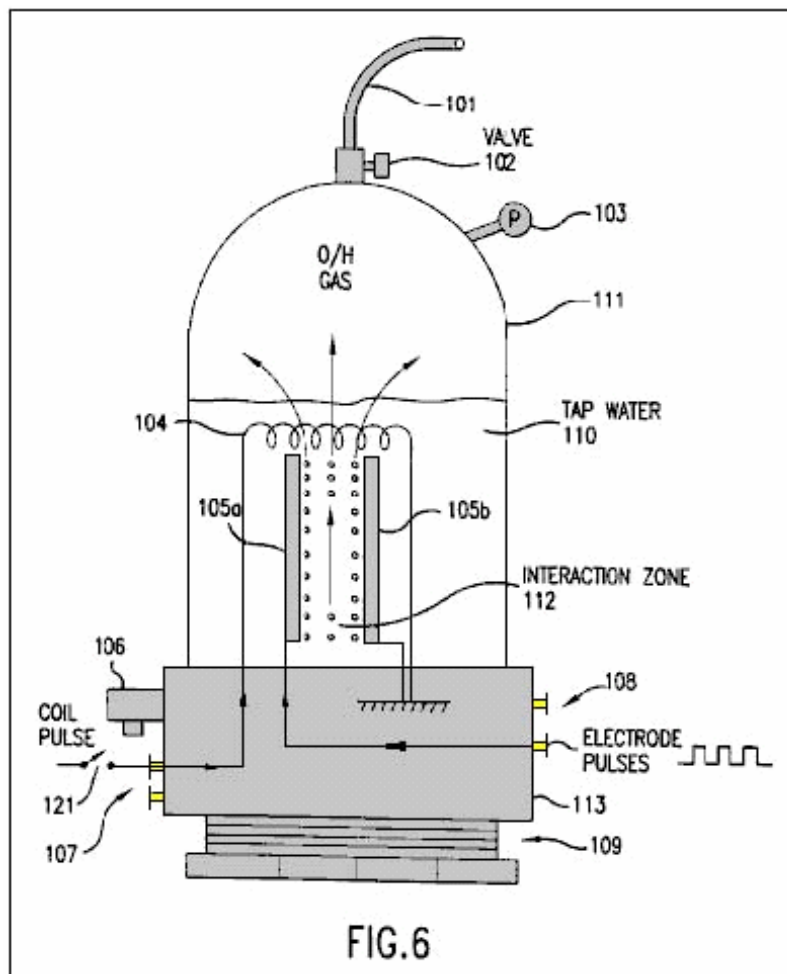

Fig.7 is a side view of a cell for producing at least parahydrogen including a coil and two pairs of electrodes according to a fifth embodiment of the present invention;

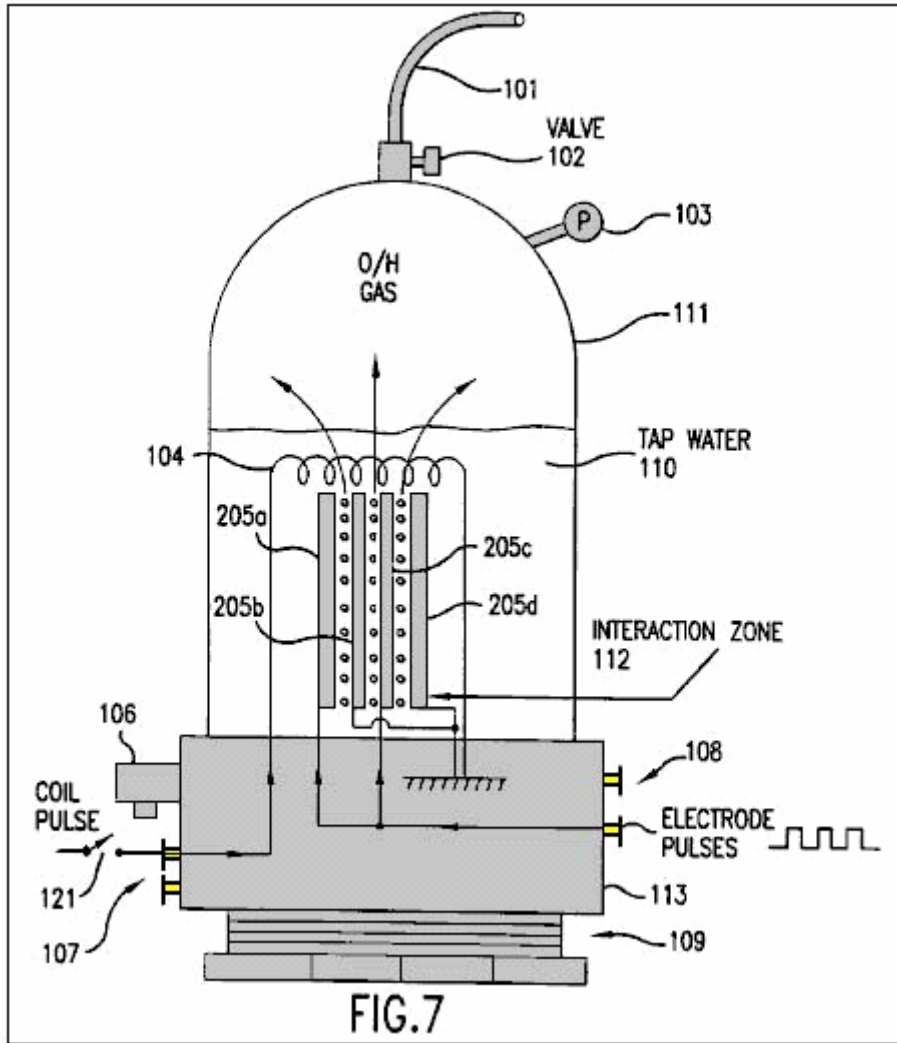

Fig.8 is a side view of a cell for producing at least parahydrogen including a coil and a pair of cylindrical-shaped electrodes according to a sixth embodiment of the present invention; and

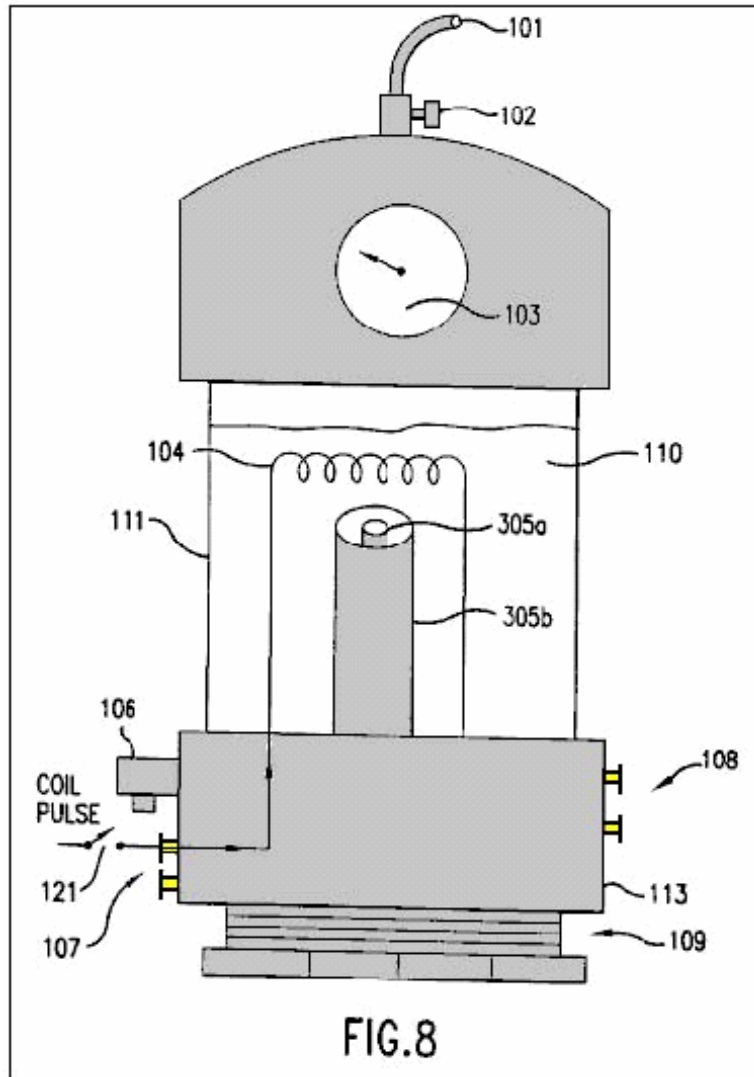
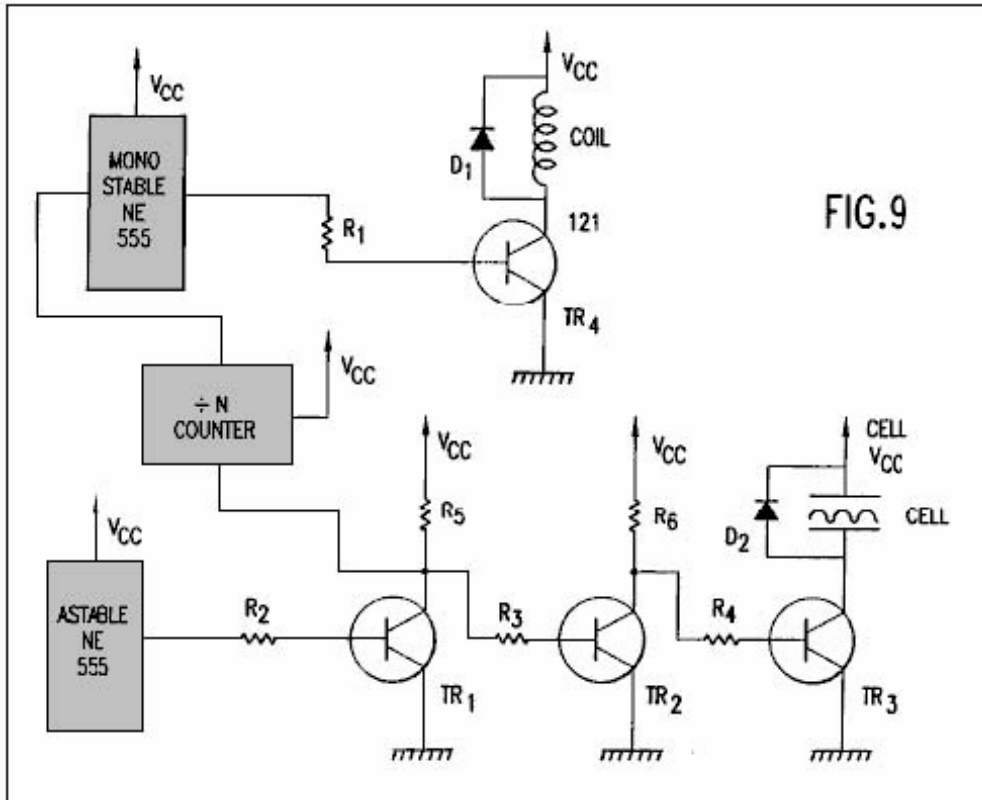

Fig.9 is an electronic circuit diagram illustrating a power supply which is connected to the coil and electrodes of **Fig.6** through **Fig.8**.



DETAILED DESCRIPTION OF THE PREFERRED EMBODIMENT

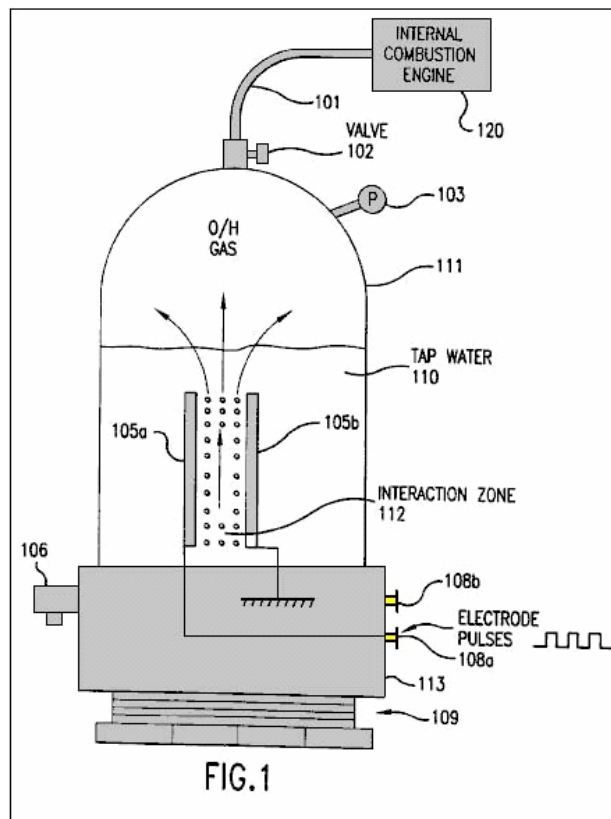

Fig.1 shows a first embodiment of the present invention including a cell for producing hydrogen and oxygen. As will be discussed below in conjunction with **Figs.6-8**, the production of parahydrogen requires an additional coil not shown in **Fig.1**. Thus, the hydrogen produced by the first embodiment of **Fig.1** is orthohydrogen.

The cell includes a closed container 111 which is closed at its bottom portion by threaded plastic base 113 and screw thread base 109. The container 111 can be made of, for example, Plexiglas and might have a height of 430 mm and a width of 90 mm. The container 111 holds tap water 110.

The cell also includes a pressure gauge 103 to measure the pressure within the container 111. An outlet valve 102 is connected to the top of the container 111 to permit any gas within the container to escape into an output tube 101.

The cell also includes an over-pressure valve 106 connected to a base 113. The valve 106 provides a safety function by automatically releasing the pressure within the container 111 if the pressure exceeds a predetermined threshold. For example, the valve 106 may be set so that it will open if the pressure in the container exceeds 75 p.s.i. Since the container 111 is built to withstand a pressure of about 200 p.s.i., the cell is provided with a large safety margin.

A pair of electrodes 105a and 105b are arranged within the container 111. These electrodes are submerged under the top level of the water 110 and define an interaction zone 112 between them. The electrodes are preferably made from the same material, such as stainless steel.

In order to produce an optimum amount of hydrogen and oxygen, an equal spacing between the electrodes 105a and 105b must be maintained. Moreover, it is preferable to minimise the spacing between the electrodes. However, the electrodes cannot be positioned excessively close together, because arcing between the electrodes would occur. It has been determined that a spacing of 1 mm is the optimum spacing for producing hydrogen and oxygen. Spacing up to 5 mm can work effectively, but spacing above 5 mm has not worked well, except with excessive power.

Hydrogen and oxygen gas may be output through tube 101 to a device 120 which can use those gases, for example an internal combustion engine, such as shown in Fig.1. Instead of an internal combustion engine, device 120 may be any device using hydrogen and oxygen, including a reciprocating piston engine, a gas turbine engine, a stove, a heater, a furnace, a distillation unit, a water purification unit, a hydrogen/oxygen jet, or other device using the gases. With an adequately productive example of the present invention, any such device 120 using the output gases can be run continuously without the need for storing dangerous hydrogen and oxygen gases.

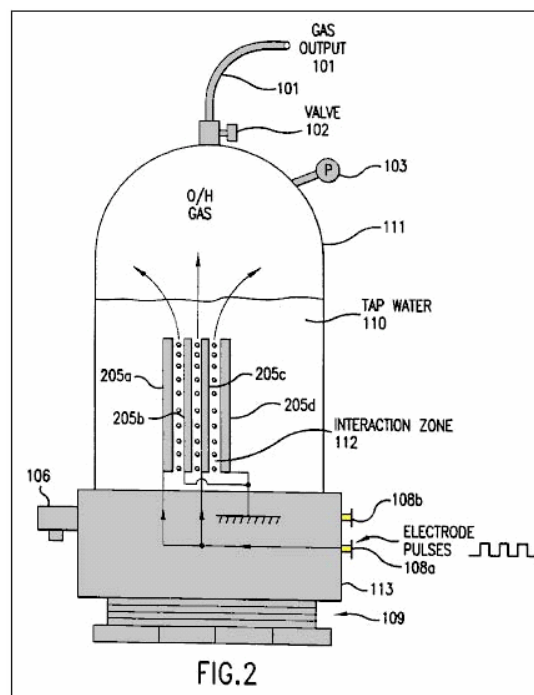

Fig.2 shows a second embodiment of the present invention which includes more than one pair of electrodes 205a-d. The spacing between the electrodes is less than 5 mm as in the embodiment of Fig.1. While Fig.2 shows only one additional pair of electrodes, it is possible to include many more pairs (e.g., as many as 40 pairs of electrodes) within the cell. The rest of the cell illustrated in Fig.2 remains the same as that illustrated in Fig.1. The multiple electrodes are preferably flat plates closely spaced, parallel to each other.

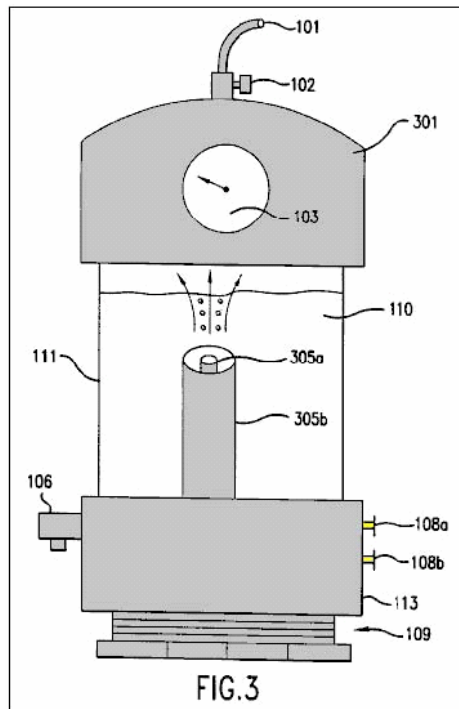

Fig.3 illustrates a cell having a cylindrically shaped electrodes **305a** and **305b**. The outer electrode **305b** surrounds the coaxially aligned inner electrode **305a**. The equal spacing of the electrodes **305a** and **305b** is less than 5 mm and the interactive zone is coaxially arranged between the two electrodes. While **Fig.3** illustrates the top portion of the container **111** being formed by a plastic cap **301**, it will be appreciated by those skilled in the art, that the cap **301** may be used in the embodiments of **Fig.1** and **Fig.2** and the embodiment of **Fig.3** can utilise the same container **111** illustrated in **Figs.1-2**. As suggested by **Fig.3**, the electrodes can be almost any shape such as flat plates, rods, tubes or coaxial cylinders.

The electrodes **105a** and **105b** of **Fig.1** (or electrodes **205a-d** of **Fig.2** or electrodes **305a** and **305b** of **Fig.3**) are respectively connected to power supply terminals **108a** and **108b** so that they can receive a pulsed electrical signal from a power supply. The pulsed signal can be almost any waveform and have a variable current level, voltage level, frequency and mark-space ratio (i.e., a ratio of the duration of a single pulse to the interval between two successive pulses). For example, the power supply providing power to the electrodes can be a mains 110 volts to a 12 volt supply or a car battery.

Fig.4a, **Fig.4b** and **Fig.4c** illustrate a square wave, a saw tooth wave and a triangular wave, respectively which can be applied to the electrodes **105a** and **105b** (or **205a-d** or **305a**, **305b**) in accordance with the present invention. Each of the waveforms illustrated in **Figs.4a-4c** has a 1:1 mark-space ratio. As shown in **Fig.4b**, the saw tooth wave will only reach a peak voltage at the end of the pulse duration. As shown in **Fig.4c**, the triangular wave has a low peak voltage. It has been found that optimal results for producing hydrogen and oxygen in the present invention are obtained using a square wave.

After initiation of the pulsed signal from the power supply, the electrodes **105a** and **105b** continuously and almost instantaneously generate hydrogen and oxygen bubbles from the water **110** in the interaction zone **112**. Moreover, the bubbles can be generated with only minimal heating of the water or any other part of the cell. These bubbles rise through the water and collect in the upper portion of the container **111**.

The generated bubbles are not bunched around or on the electrodes **105a** and **105b** and thus readily float to the surface of the water. Therefore, there is no need to add a chemical catalyst to assist the conduction of the solution or reduce the bubble bunching around or on the electrodes. Thus, only tap water is needed for generation of the hydrogen and oxygen in the present invention.

The gases produced within the container are self-pressurising (i.e., pressure builds in the container by the production of gas, without an air pump). Thus, no additional pump is needed to be coupled to the container **111** and the produced gases do no need to be transported into a pressurised container.

The power supply in the present invention is required to provide a pulsed signal having only 12 volts at 300 mA (3.6 watts). It has been found that an optimal amount of hydrogen and oxygen has been produced when the pulsed signal has mark-space ratio of 10:1 and a frequency of 10-250 KHz. Using these parameters, the prototype cell of the present invention is capable of producing gas at the rate of 1 p.s.i. per minute. Accordingly,

the cell of the present invention is capable of producing hydrogen and oxygen in a highly efficient manner, quickly and with low power requirements.

As noted above, the hydrogen produced by the embodiments of **Figs.1-3** is orthohydrogen. As is well understood by those skilled in the art, orthohydrogen is highly combustible. Therefore, any orthohydrogen produced can be transported from the container **111** through valve **102** and outlet tube **101** to be used by a device such as an internal combustion engine.

The present invention, with sufficient electrodes, can generate hydrogen and oxygen fast enough to feed the gases directly into an internal combustion engine or turbine engine, and run the engine continuously without accumulation and storage of the gases. Hence, this provides for the first time a hydrogen/oxygen driven engine that is safe because it requires no storage of hydrogen or oxygen gas.

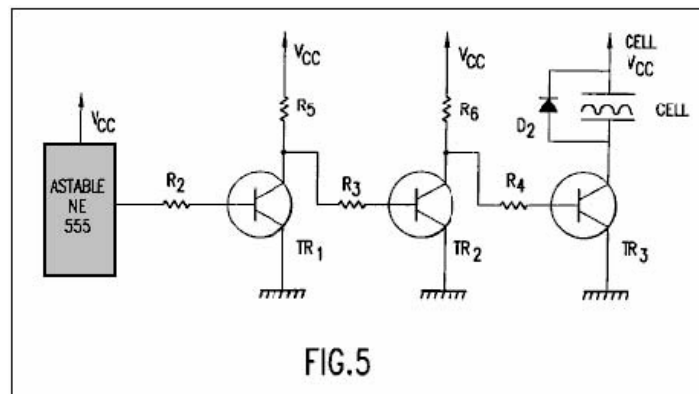

Fig.5 illustrates an exemplary power supply for providing D.C. pulsed signals such as those illustrated in **Figs.4a-4c** to the electrodes illustrated in **Figs.1-3**. As will be readily understood by those skilled in the art, any other power supply which is capable of providing the pulsed signals discussed above can be substituted. The power supply illustrated in **Fig.5** includes the following parts, components and values:

The astable circuit is connected to the base of transistor **TR1** through resistor **R2**. The collector of transistor **TR1** is connected to voltage supply **Vcc** through resistor **R5** and the base of transistor **TR2** through resistor **R3**. The collector of transistor **TR2** is connected to voltage supply **Vcc** through resistor **R6** and the base of transistor **TR3** through resistor **R4**. The collector of transistor **TR3** is connected to one of the electrodes of the cell and diode **D2**. The emitters of transistors **TR1**, **TR2** and **TR3** are connected to ground. Resistors **R5** and **R6** serve as collector loads for transistors **TR1** and **TR2**, respectively. The cell serves as the collector load for transistor **TR3**. Resistors **R2**, **R3** and **R4** ensure that transistors **TR1**, **TR2** and **TR3** are saturated. Diode **D2** protects the rest of the circuit from any induced back emf within the cell.

The astable circuit is used to generate a pulse train at a specific time and with a specific mark-space ratio. This pulse train is provided to the base of transistor **TR1** through resistor **R2**. Transistor **TR1** operates as an invert switch. Thus, when the astable circuit produces an output pulse, the base voltage of the transistor **TR1** goes high (i.e. close to **Vcc** or logic 1). Hence, the voltage level of the collector of transistor **TR1** goes low (i.e., close to ground or logic 0).

Transistor **TR2** also operates as an inverter. When the collector voltage of transistor **TR1** goes low, the base voltage of transistor **TR2** also goes low and transistor **TR2** turns off. Hence, the collector voltage of transistor **TR2** and the base voltage of Transistor **TR3** go high. Therefore, transistor **TR3** turns on with the same mark-space ratio as the astable circuit. When the transistor **TR3** is on, one electrode of the cell is connected to **Vcc** and the other is connected to ground through transistor **TR3**. Thus, the transistor **TR3** can be turned on (and off) and therefore the transistor **TR3** effectively serves as a power switch for the electrodes of the cell.

Figs.6-8 illustrate additional embodiments of the cell which are similar to the embodiments of **Figs.1-3**, respectively. However, each of the embodiments of **Figs.6-8** further includes a coil **104** arranged above the electrodes and power supply terminals **107** connected to the coil **104**. The dimensions of coil **104** can be, for example, 5 x 7 cm and have, for example, 1500 turns. The coil **104** is submerged under the surface of the water **110**.

The embodiments of **Figs.6-8** further include an optional switch **121** which can be switched on or off by the user. When the switch **121** is not closed, then the cell forms basically the same structure as **Figs.1-3** and thus can be operated in the same manner described in **Figs.1-3** to produce orthohydrogen and oxygen. When the switch **121** is closed, the additional coil **104** makes the cell capable of producing oxygen and either (1) parahydrogen or (2) a

mixture of parahydrogen and orthohydrogen.

When the switch **121** is closed (or not included), the coil **104** is connected through terminals **106** and the switch **121** (or directly connected only through terminals **106**) to a power supply so that the coil **104** can receive a pulsed signal. As will be discussed below, this power supply can be formed by the circuit illustrated in **Fig.9**.

When the coil **104** and the electrodes **105a** and **105b** receive pulses, it is possible to produce bubbles of parahydrogen or a mixture of parahydrogen and orthohydrogen. The bubbles are formed and float to the surface of the water **110** as discussed in **Figs.1-3**. When the coil is pulsed with a higher current, a greater amount of parahydrogen is produced. Moreover, by varying the voltage of the coil **104**, a greater/lesser percentage of orthohydrogen/parahydrogen can be produced. Thus, by controlling the voltage level, current level and frequency (discussed below) provided to the coil **104** (and the parameters such as voltage level, current level, frequency, mark-space ratio and waveform provided to the electrodes **105a** and **105b** as discussed above) the composition of the gas produced by the cell can be controlled. For example, it is possible to produce only oxygen and orthohydrogen by simply disconnecting the coil **104**. It is also possible to produce only oxygen and parahydrogen by providing the appropriate pulsed signals to the coil **104** and the electrodes **105a** and **105b**. All of the benefits and results discussed in connection with the embodiments of **Figs.1-3** are equally derived from the embodiments of **Figs.6-8**. For example, the cells of **Figs.6-8** are self-pressurising, require no-chemical catalyst, do not greatly heat the water **110** or cell, and produce a large amount of hydrogen and oxygen gases from a modest amount of input power, without bubbles on the electrodes.

A considerable amount of time must pass before the next pulse provides current to the coil **104**. Hence, the frequency of the pulsed signal is much lower than that provided to the electrodes **105a** and **105b**. Accordingly, with the type of coil **104** having the dimensions described above, the frequency of pulsed signals can be as high as 30 Hz, but is preferably 17-22 Hz to obtain optimum results.

Parahydrogen is not as highly combustible as orthohydrogen and hence is a slower burning form of hydrogen. Thus, if parahydrogen is produced by the cell, the parahydrogen can be coupled to a suitable device such as a cooker or a furnace to provide a source of power or heat with a slower flame.

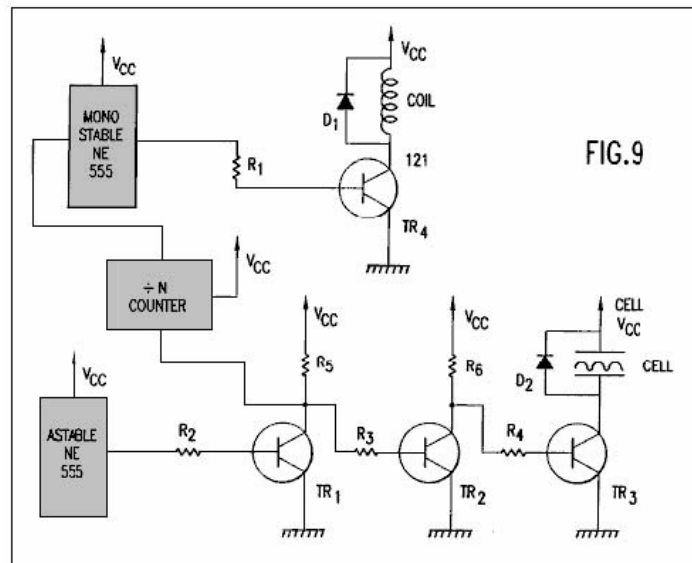

Fig.9 illustrates an exemplary power supply for providing D.C. pulsed signals such as those illustrated in **Figs.4a-4c** to the electrodes illustrated in **Figs.6-8**. Additionally, the power supply can provide another pulsed signal to the coil. As will be readily understood by those skilled in the art, any other power supply which is capable of providing the pulsed signals discussed above to the electrodes of the cell and the coil can be substituted. Alternatively, the pulsed signals provided to the electrodes and the coil can be provided by two separate power supplies.

The portion of the power supply (astable circuit, **R2-R6**, **TR1-TR3**, **D2**) providing a pulsed signal to the electrodes of the cell is identical to that illustrated in **Fig.5**. The power supply illustrated in **Fig.9** further includes the following parts and their respective exemplary values:

The input of the 'divide-by-N' counter (hereinafter "the divider") is connected to the collector of transistor **TR1**. The output of the divider is connected to the monostable circuit and the output of the monostable circuit is connected to the base of transistor **TR4** through resistor **R1**. The collector of transistor **TR4** is connected to one end of the coil and a diode **D1**. The other end of the coil and the diode **D1** are connected to the voltage supply

Vcc. Resistor **R1** ensures that **TR4** is fully saturated. Diode **D2** prevents any induced back emf generated within the coil from damaging the rest of the circuit. As illustrated in **Figs.6-8**, a switch **121** can also be incorporated into the circuit to allow the user to switch between (1) a cell which produces orthohydrogen and oxygen, and (2) a cell which produces at least parahydrogen and oxygen.

The high/low switching of the collector voltage of transistor **TR1** provides a pulsed signal to the divider. The divider divides this pulsed signal by N (where N is a positive integer) to produce a pulsed output signal. This output signal is used to trigger the monostable circuit. The monostable circuit restores the pulse length so that it has a suitable timing. The output signal from the monostable circuit is connected to the base of transistor **TR4** through resistor **R1** to switch transistor **TR4** on/off. When transistor **TR4** is switched on, the coil is placed between **Vcc** and ground. When the transistor **TR4** is switched off, the coil is disconnected from the rest of the circuit. As discussed in conjunction with **Figs.6-8**, the frequency of pulse signal provided to the coil is switched at a rate preferably between 17-22 Hz; i.e., much lower than the frequency of the pulsed signal provided to the electrodes.

As indicated above, it is not required that the circuit (divider, monostable circuit, **R1**, **TR4** and **D1**) providing the pulsed signal to the coil be connected to the circuit (astable circuit, **R2-R6**, **TR1-TR3**, **D2**) providing the pulsed signal to the electrodes. However, connecting the circuits in this manner provides an easy way to initiate the pulsed signal to the coil.

A working prototype of the present invention has been successfully built and operated with the exemplary and optimal parameters indicated above to generate orthohydrogen, parahydrogen and oxygen from water. The output gas from the prototype has been connected by a tube to the manifold inlet of a small one cylinder gasoline engine, with the carburettor removed, and has thus successfully run such engine without any gasoline:

CHARLES GARRETT

US Patent 2,006,676

2nd July 1935

Inventor: Charles H. Garrett

ELECTROLYTIC CARBURETTOR

Please note that this is a re-worded excerpt from this patent. It describes an electrolyser which Charles claimed was able to generate enough gas from hydrolysis of water, to be able to run a car engine without the use of any other fuel. It should be remembered that in Garrett's day, car electrics were all 6-volt systems.

DESCRIPTION

This invention relates to carburettors and it has particular reference to an electrolytic carburettor by means of which water may be broken up into its hydrogen and oxygen constituents and the gases so formed suitably mixed with each other and with air.

Another object of the invention is to provide a means whereby the electrolyte level in the carburettor may be maintained at a more or less constant level regardless of fluctuations in water pressure at the water inlet of the carburettor.

Another object of the invention is to provide a means whereby the relative amount of air mixed with the hydrogen and oxygen may be regulated as desired.

Still another object of the invention is the provision of a means to prevent the loss of hydrogen and oxygen gases during periods in which these gases are not being drawn from the carburettor.

Still another object of the invention is the provision of a means whereby the hydrogen and oxygen resulting from electrolysis may be formed in separate compartments, and a further object of the invention is the provision of a means to periodically reverse the direction of current flow and thereby alternate the evolution of the gases in the separate compartments, to be intermingled at a later time.

With reference to the accompanying drawings: -

Figure 1 is a view in vertical section of one form of carburettor.

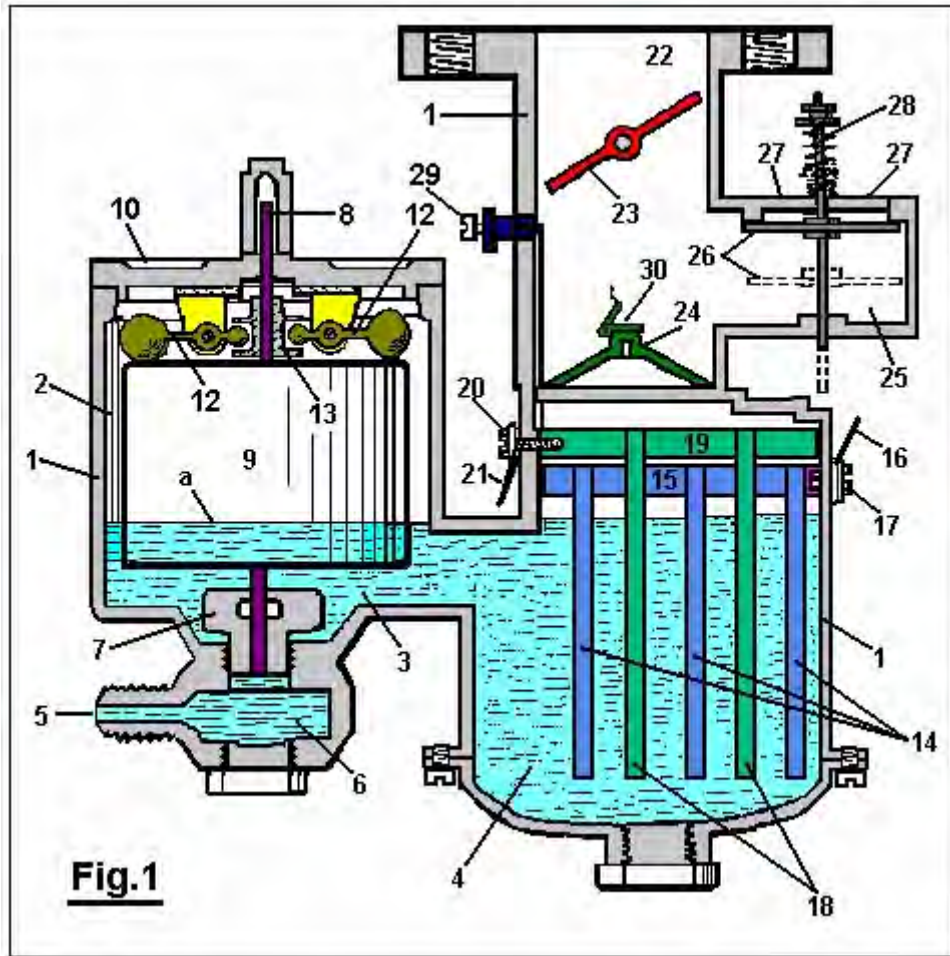

Figure 2 is a modified form.

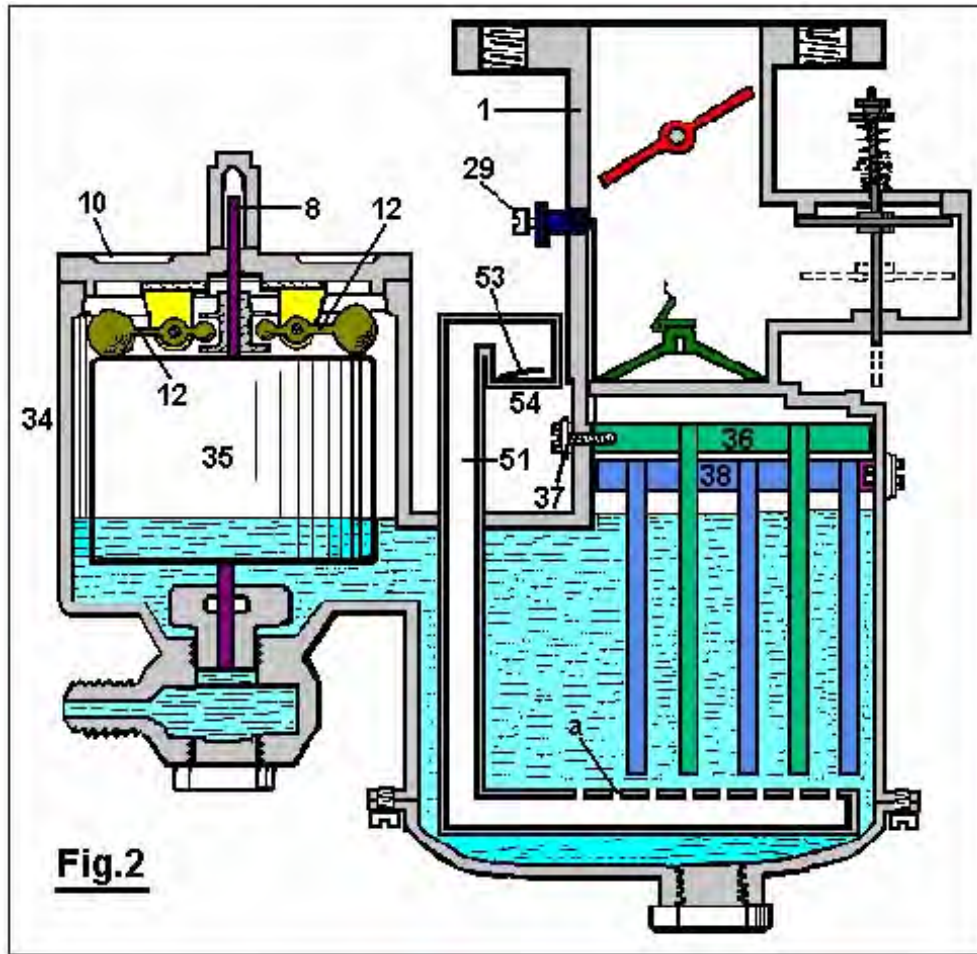

Figure 3 is a diagrammatic view of a pole changer, showing its actuating mechanism, and

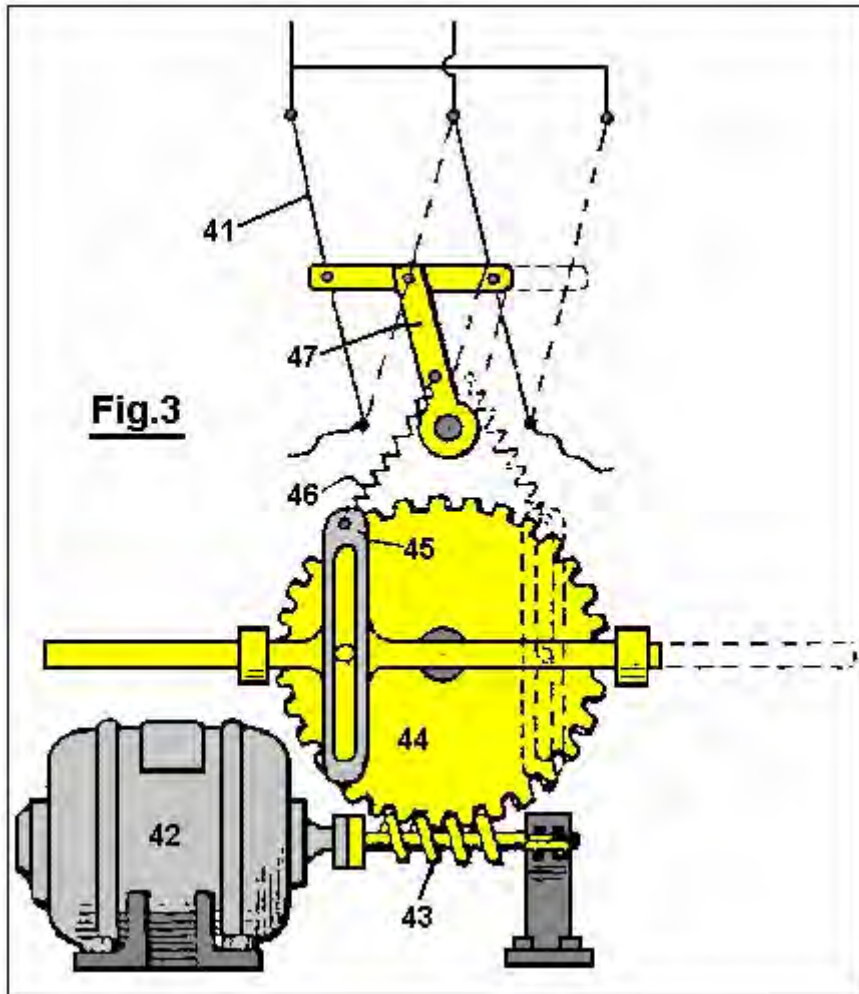
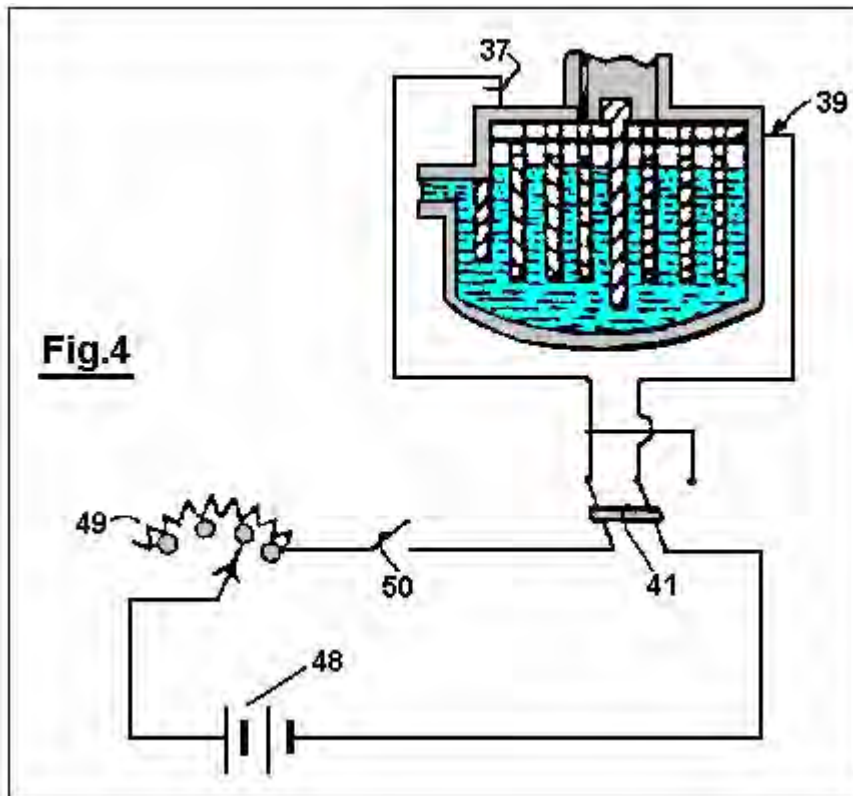
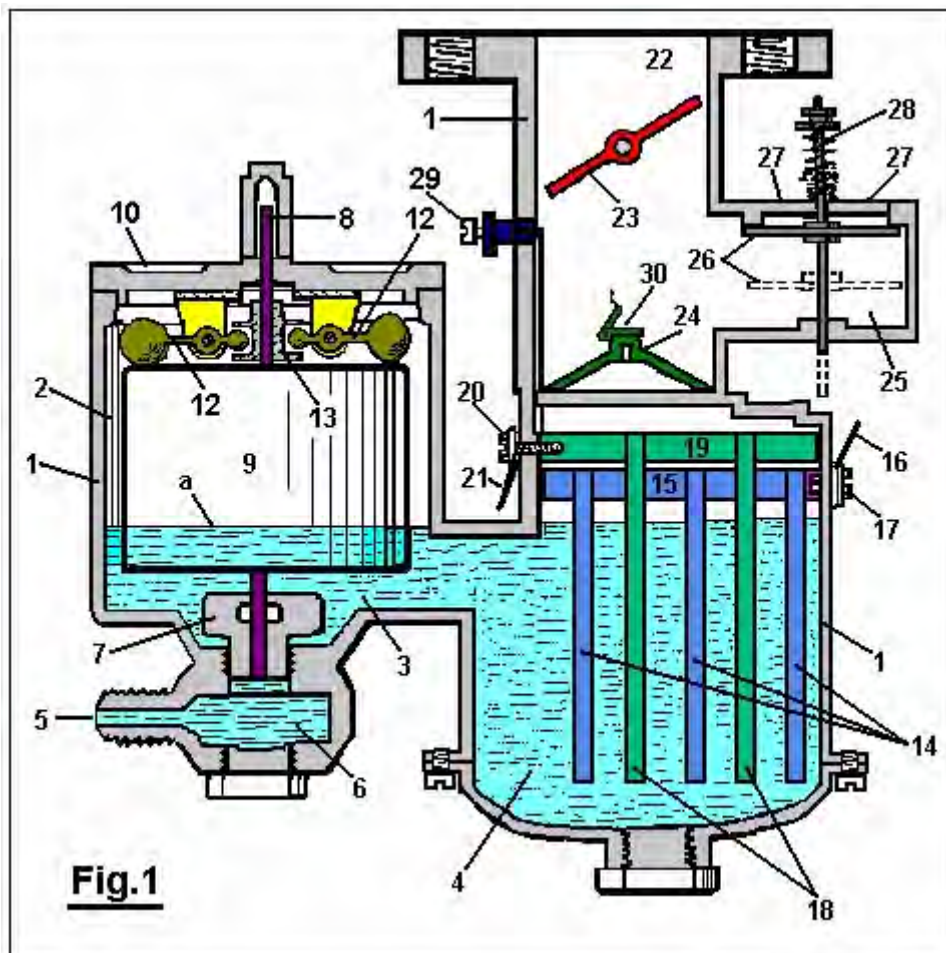

Figure 4 is a wiring diagram for the modified form of carburettor shown in Figure 2.



With reference to **Fig.1**: The reference numeral 1 designates the carburettor housing, which is preferably constructed of bakelite or other suitable insulating material. This housing is designed so as to divide the carburettor into a float chamber 2 and gas generating chamber 4, connected by a fluid passage 3.



Water under pressure is forced into the carburettor through an opening **5** which communicates with the float chamber **2** through the medium of the sediment chamber **6** and the needle valve orifice **7**, which is closed by a needle valve **8** when the device is not in operation. A float **9** surrounds the needle valve **8** and is free to move vertically relative thereto. Descending from the cover **10** to the float chamber **2** are two ears **11**, located at spaced intervals on opposite sides of the needle valve **8**. The members **12** are pivoted to the ears **11**, as shown. The weighted outer ends of the members **12** rest on top of the float **9**, and their inner ends are received in an annular groove in the collar **13** which is rigidly attached to the needle valve **8**.

Within the gas generating chamber **4**, a series of spaced, descending plates **14** are suspended from a horizontal member **15** to which a wire **16** has electrical contact through the medium of the bolt **17**, which extends inwards through housing **1** and is threaded into the horizontal member **15**.

A second series of plates **18** is located between the plates **14** and attached to the horizontal member **19**, and has electrical contact with the wire **20** through the bolt **21**.

A gas passageway **22**, in which a butterfly valve **23** is located, communicates with the gas generating chamber **4** through an orifice **24**. An air inlet chamber **25** has communication with the gas passageway **22** above the orifice **24**. A check valve **26** which opens downwards, controls the openings **27**, and is held closed and inoperative by means of light spring **28**.

An adjustable auxiliary air valve **29** is provided in the wall of the gas passageway **22**, which air valve is closed by the butterfly valve **23** when the butterfly valve is closed, but communicates with the outside air when the butterfly valve is open.

The operation of the device is as follows :

The chambers **2** and **4** are first filled to the level 'a' with a solution of weak sulphuric acid (or other electrolyte not changed by the passage of current through it), and the opening **5** is connected to a tank of water (not shown).

The wire **16** is next connected to the positive pole of a storage battery or other source of direct current and the wire **20** to the negative pole. Since the solution within the carburettor is a conductor of electricity, current will flow through it and hydrogen will be given off from the negative or cathode plates **18** and oxygen from the positive or anode plates **14**.

The butterfly valve **23** is opened and the gas passageway **22** brought into communication with a partial vacuum. Atmospheric pressure acting on the top of the check valve **26** causes it to be forced downwards as shown in dotted lines. The hydrogen and oxygen liberated from the water at the plates **18** and **14** are drawn upwards through the orifice **24** covered by the check valve **30** where they are mixed with air entering through the openings **27** and through the auxiliary air valve **29**.

When it is desired to reduce the flow of hydrogen and oxygen from the plates **18** and **14**, the current flowing through the device is reduced, and when the current is interrupted the flow ceases. When the butterfly valve **23** is moved to its 'closed' position, the check-valve **26** is automatically closed by the spring **28**. Any excess given off during these operations is stored in the space above the fluid where it is ready for subsequent use.

Water is converted into its gaseous constituents by the device herein described, but the dilute sulphuric acid or other suitable electrolyte in the carburettor remains unchanged, since it is not destroyed by electrolysis, and the parts in contact therewith are made of bakelite and lead or other material not attacked by the electrolyte.

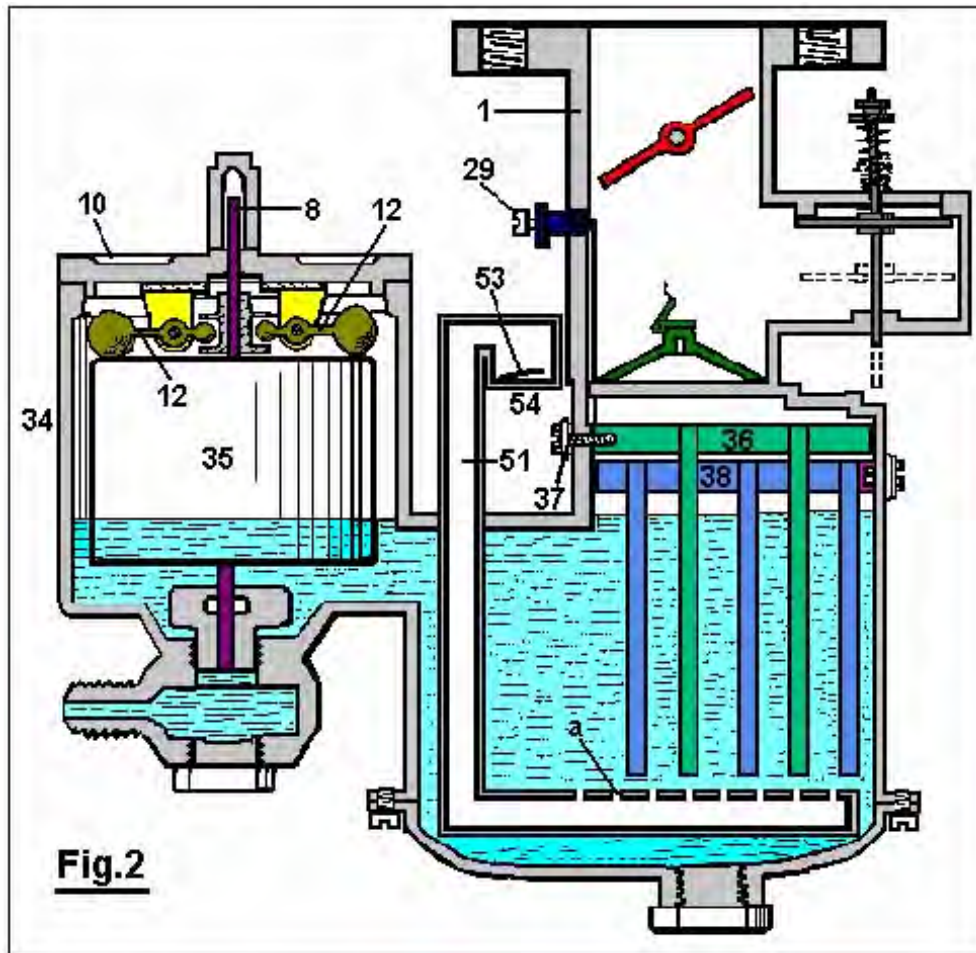

Fig.2

The structure shown in **Fig.2** is substantially the same as that shown in **Fig.1** with the exception that the modified structure embraces a larger gas generating chamber which is divided by means of an insulating plate **31** and is further provided with a depending baffle plate **32** which separates the gas generating chamber **33** from the float chamber **34** in which the float **35** operates in the same manner as in **Fig.1**. Moreover, the structure shown in **Fig.2** provides a series of spaced depending plates **36** which are electrically connected to the wire **37**, and a second series of similar plates **38** which are electrically connected to the wire **39** and are kept apart from the plates **36** by the insulating plate **31**.

Gases generated on the surfaces of the plates **36** and **38** pass upward through the orifice **39a** into the gas passageway **40** where they are mixed with air as explained in the description of **Fig.1**.

A pipe **51**, bent as shown in **Fig.2**, passes downwards through the housing of the carburettor and has a series of spaced apertures 'a' in its horizontal portion beneath the plates **36** and **38**. Check valve **53**, with opens upwards, controls air inlet **54**. When a partial vacuum exists in the chamber **33**, air is drawn in through the opening **54** and then passes upwards through the apertures 'a'. This air tends to remove any bubbles of gas collecting on the plates **36** and **38** and also tends to cool the electrolyte. The check valve **53** automatically closes when a gas pressure exists within the carburettor and thereby prevents the electrolyte from being forced out of the opening **54**.

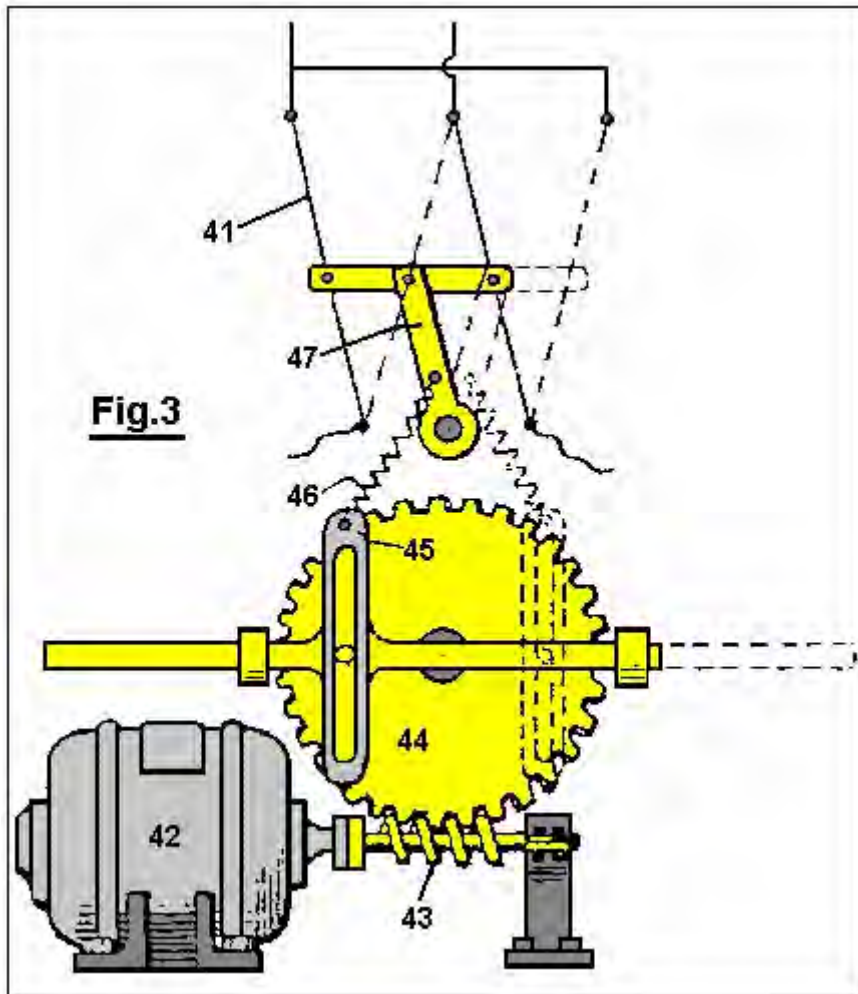

Fig.3

In order to provide for alternate evolution of the gases from the plates **36** and **38**, a pole changer **41**, shown in **Fig.3**, is actuated periodically by the motor **42** which drives the worm **43** and the gear **44** and causes oscillations of the member **45** which is connected by a spring **46** to the arm **47**, thereby causing the pole changer to snap from one position to the other.

In operation, the carburettor shown in **Fig.2** is connected as shown in the wiring diagram of **Fig.4**. A storage battery **48** or other suitable source of direct current is connected to a variable rheostat **49**, switch **50**, pole changer **41** and to the carburettor as shown. Thus the rate of evolution of the gases can be controlled by the setting of the rheostat **49** and the desired alternate evolution of the gases in the compartments of the carburettor is accomplished by means of the periodically operated pole changer **41**.

Manifestly, the construction shown is capable of considerable modification and such modification as is considered within the scope and meaning of the appended claims is also considered within the spirit and intent of the invention.

ARCHIE BLUE

US Patent 4,124,463

7th November 1978

Inventor: Archie H. Blue

ELECTROLYTIC CELL

Please note that this is a re-worded excerpt from this patent. It describes an electrolyser system where air is drawn through the electrolyte to dislodge bubbles from the electrodes.

ABSTRACT

In the electrolytic production of hydrogen and oxygen, air is pumped through the cell while the electrolysis is in progress so as to obtain a mixture of air, hydrogen and oxygen.

BACKGROUND AND BRIEF DESCRIPTION OF THE INVENTION

This invention relates to the production of gases which can be utilised primarily, but not necessarily, as a fuel.

To decompose water electrically, it is necessary to pass direct current between a pair of electrodes which are immersed in a suitable electrolyte. During such electrolysis, it is normal to place some form of gas barrier between the two electrodes, in order to prevent the gases produced forming an explosive mixture. However provided suitable precautions are taken, it has been found that the gases can be allowed to mix and can be fed into a storage tank for subsequent use. Because the gases when mixed form an explosive mixture, it is possible for the mixture to be utilised, for instance, as a fuel for an internal combustion engine. In such circumstances it is desirable that the gases should also be mixed with a certain proportion of air in order to control the explosive force which results when the gases are ignited.

One of the difficulties encountered with electrolysis is that bubbles of gas are liable to remain on the electrodes during the electrolysis thus effectively limiting the area of electrode which is in contact with the electrolyte and preventing optimum current flow between the electrodes. Because it is desirable that the gases evolved during the electrolysis be mixed with air, it is possible for air to be passed through the cell while electrolysis is in progress. The passage of air through the cell can be directed past the electrodes so as to pick up any gas bubbles on the electrodes.

Accordingly, the invention comprises an electrolytic cell with a gas tight casing, several electrodes supported on a central post within the cell, spaced apart and electrically insulated from each other, each alternative electrode being connected to a positive direct current source or a negative direct current source respectively and wherein the central post is in the form of a tube, one end of which is extended out of the cell and connected to a source of air under pressure, with the other end of the central post terminating in an air outlet below the electrodes. The cell also includes a gas outlet to carry the air forced into the cell through the central post and to exhaust the gases produced by electrolysis.

DETAILED DESCRIPTION OF THE INVENTION

Various forms of the invention will now be described with the aid of the accompanying drawings wherein:

Fig.1 is a diagrammatic elevational view partly in section of one form of the invention,

FIG. 1

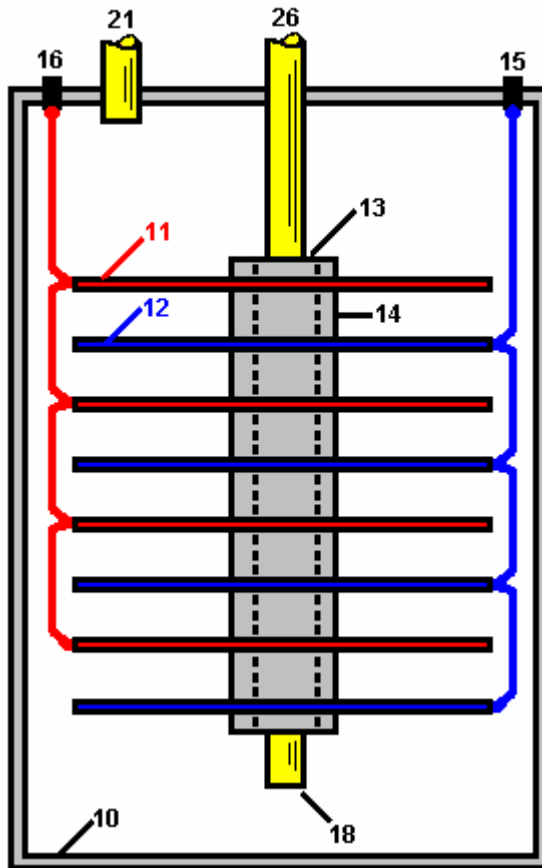

Fig.2 is a diagrammatic elevational view partly in section of a modified form of the invention,

FIG. 2

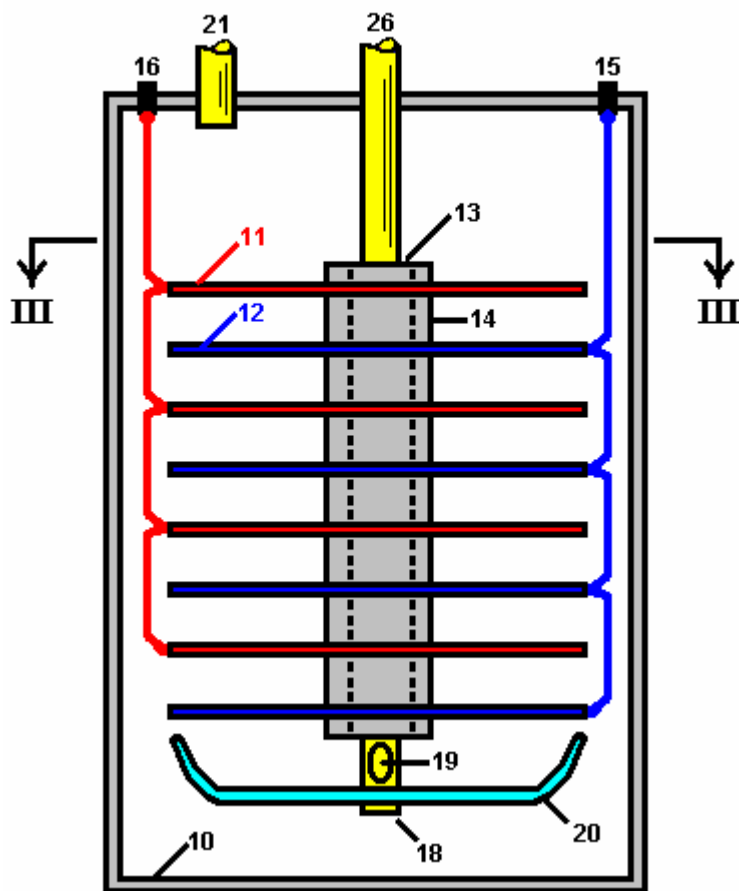
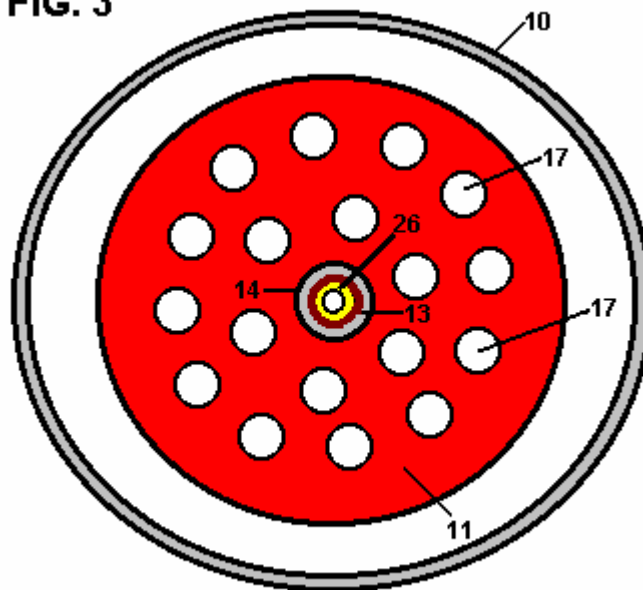

Fig.3 is a section along the line III-III of Fig.2.

FIG. 3



Section III - III

FIG. 1

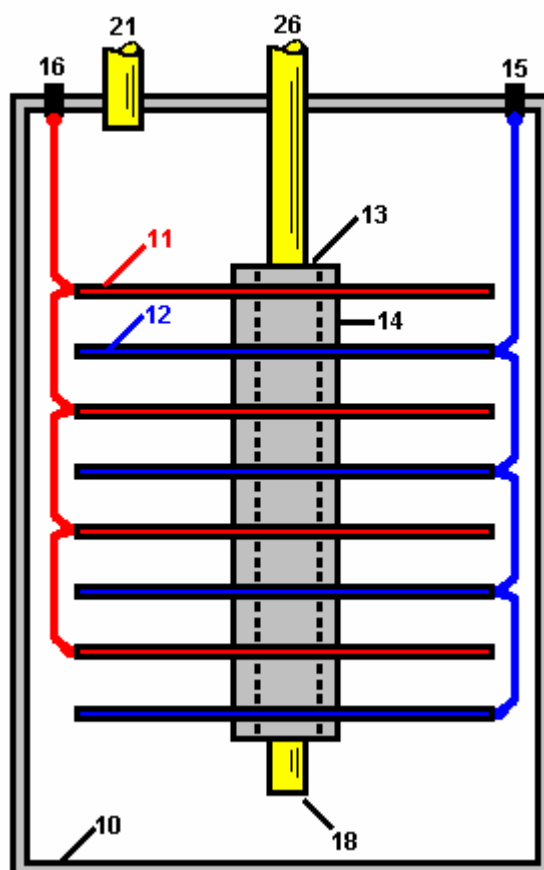

The cell as shown in **Fig.1** comprises a gas-tight casing **10** which is formed from a material incapable of corrosion, such as plastic. Several cathode plates **11** and several anode plates **12** are supported within the cell on an electrically insulating central post **13**, with the cathode plates and anode plates being spaced apart by means of insulating spacers **14**. The anode plates **12** are all connected in parallel to a positive terminal post **15** while the cathode plates are all connected in parallel to the negative terminal post **16**, these connections being indicated in dotted lines in the drawings. The cathode and anode plates are preferably in the form of discs made from a metal suited to the electrolyte, thus ensuring a satisfactory cell life. These plates may be shaped to conform with the shape of the walls of the cell which may be circular in cross section as indicated or any other desired shape.

The central post **26** is preferably in the form of a tube which extends out of the cell. The lower end of the tube **18** is open so that air can be pumped into the cell through the central post **26** and enter the cell via the lower end **18** where it will pass up through the electrolyte. This keeps the electrolyte in constant motion which assists in the rapid removal of any gas bubbles which may be adhering to the electrode plates.

FIG. 2

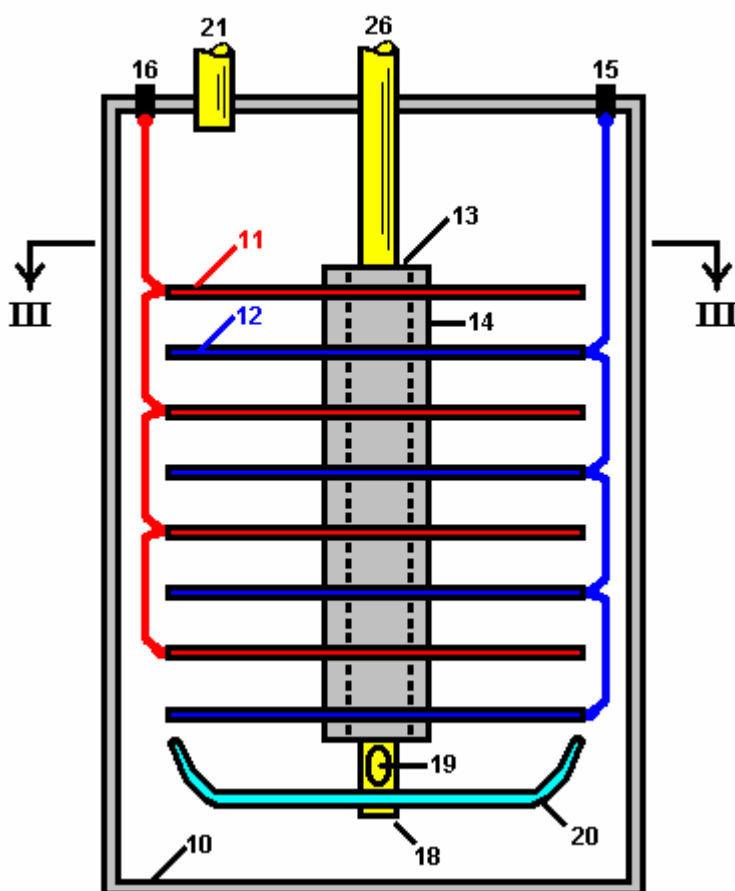

In the modification shown in **Fig.2** and **Fig.3**, each electrode plate is provided with holes **17**. The central post **26** is also provided with at least one air hole **19** adjacent to its the lower end. A deflector plate **20** is also supported by the central post **26**, this plate being dish shaped so as to deflect air issuing out of the air hole **19** up through the holes **17** in the electrodes. This further assists in dislodging any bubbles of gas clinging to the electrode plates.

The cell also includes a gas outlet **21** so that the air which enters the cell, together with the gases produced by electrolysis, can be taken out of the cell into a suitable storage tank (not shown in the drawings). If desired, such storage tank can be arranged to accept the gases under pressure and for this purpose the air pumped into the cell will be pumped in under the required pressure. A gas drier (not shown in the drawings) can also be interposed between the gas outlet **21** and the storage tank.

Although the electrolysis will naturally produce considerable heat, nevertheless it can be found advantageous to install a heater in the cell, preferably in the bottom of the cell, to assist and facilitate the warming up of the electrolyte so that the cell reaches its most efficient operating conditions as quickly as possible.

Preferably also, a current-control device should be employed so that the intensity of the electrolytic action can be controlled.

A mechanism may also be provided for the automatic replenishment of water within the cell as the level of the electrolytic drops during use.

While it is recognised that the mixing of hydrogen and oxygen will create a dangerous explosive mixture, nevertheless by carrying out the invention as described above, the risk of explosion is minimised. The gases produced can be utilised, for instance, as a fuel to power an internal combustion engine and for this purpose it is desirable, as already mentioned, to mix a proportion of air with the gases produced during electrolysis, so that when the mixture is ignited within the cylinder or cylinders of the engine, the explosive force so created can be of the desired amount.

While in the foregoing description reference is made to the utilisation of the mixed gases as a fuel, it will of course be understood that the gases can be separated for individual use.

CLAIMS

1. A process for producing, Through the electrolysis of an aqueous liquid, a combustible mixture of hydrogen, oxygen and air. This is achieved in an electrolytic cell having a gas-tight casing, a substantially central tubular post mounted in the casing and having an air inlet at its upper end, and a several electrodes supported on the post and axially spaced along it, alternate electrodes being connected to a first electrical terminal and to a second electrical terminal respectively connected to a respective poles of a current source and being mutually insulated, the post having an air outlet below the electrodes out of which flows air from the air inlet into the cell and over the electrodes; and a source of air under pressure connected to the said air inlet forcing a flow of air through the aqueous liquid contained in the cell; the cell having in its upper region a common outlet exhausting the combustible mixture comprising air forced through the cell, along with hydrogen and oxygen produced by electrolysis in the cell.
2. The process according to claim 1 wherein the electrodes are discs each having a several holes through them.
3. The process according to claim 1 further including a dish-shaped air deflector plate supported on the post below the air outlet.
4. Apparatus for producing by electrolysis of an aqueous liquid, a combustible mixture of hydrogen and oxygen, comprising: an electrolytic cell having a gas-tight casing, a substantially central tubular post mounted in the casing and having an air inlet at its upper end, and a plurality of electrodes supported on the post and axially spaced along it, alternate electrodes being connected to a first electrical terminal and to a second electrical terminal respectively for connection to respective poles of a current source and being mutually insulated, the post having an air outlet below the electrodes for flow of air from the air inlet into the cell and over the electrodes; a dish-shaped air deflector supported on said post below said air outlet; and a source of air under pressure connected to the said air inlet for forcing a flow of air through the aqueous liquid contained in the cell in operation thereof; the cell having in its upper region a common outlet for exhausting the combustible mixture comprising air forced through the cell and hydrogen and oxygen produced by electrolysis of the liquid in the cell.
5. The apparatus according to claim 4 wherein the electrodes are discs each having a several holes through them.

Durable and Efficient Equipment for the Production of a Combustible and Non-Pollutant Gas from Underwater Arcs and Method therefor

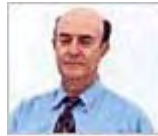

Please note that this is a re-worded excerpt from this patent. It shows how electrolysis of water can be carried out on a large scale as a continuous process.

ABSTRACT

A system for producing a clean burning combustible gas comprising an electrically conductive first electrode and an electrically conductive second electrode. A motor coupled to the first electrode is adapted to move the first electrode with respect to the second electrode to continuously move the arc away from the plasma created by the arc. A water-tight container for the electrodes is provided with a quantity of water within the tank sufficient to submerge the electrodes.

BACKGROUND OF THE INVENTION

1. Field of the Invention

The present invention relates to durable and efficient equipment for the production of a combustible and non-polluting gas from underwater arcs and the method for doing this and more particularly, the invention pertains to producing a combustible gas from the underwater arcing of electrodes which move with respect to each other.

2. Description of the Prior Art

The combustible nature of the gas bubbling to the surface from an underwater welding arc between carbon electrodes was discovered and patented in the last century. Various improved equipment for the production of said combustible gas have been patented during this century. Nevertheless, the technology has not yet reached sufficient maturity for regular industrial and consumer production and sales because of numerous insufficiencies, including excessively short duration of the carbon electrodes which requires prohibitive replacement and service, as well as low efficiency and high content of carbon dioxide responsible for the greenhouse effect. As a result of numerous experiments, this invention deals with new equipment for the production of a combustible gas from underwater arcs between carbon electrodes which resolves the previous problems, and achieves the first known practical equipment for industrial production and sales.

The technology of underwater electric welding via the use of an arc between carbon electrodes to repair ships, was established in the last century. It was then discovered that the gas bubbling to the surface from underwater arcs is combustible. In fact, one of the first U.S. patents on the production of a combustible gas via an underwater electric arc between carbon electrodes dates back to 1898 (U.S. Pat. No. 603,058 by H. Eldridge).

Subsequently, various other patents were obtained in this century on improved equipment for the production of this combustible gas, among which are:

US Pat. No. 5,159,900 (W.A. Dammann and D. Wallman, 1992);
5,435,274 (W. H. Richardson, Jr., 1995);
5,417,817 (W. A. Dammann and D. Wallman, 1995);
H. Richardson, Jr., 1997);
Richardson, Jr., 1998); and
Jr., 1998).

U.S.Pat. No.
U.S. Pat. No.
U.S. Pat. No. 5,692,459 (W.
U.S. Pat. No. 5,792,325 (W. H.
U.S. Pat. No. 5,826,548 (W. H. Richardson,

The main process in these inventions is essentially the following. The arc is generally produced by a DC power unit, such as a welder, operating at low voltage (25-35 V) and high current (300 A to 3,000 A) depending on the available Kwh input power. The high value of the current brings the tip of the carbon electrode in the cathode to incandescence, with the consequential disintegration of the carbon crystal, and release of highly ionised carbon atoms to the arc. Jointly, the arc separates the water into highly ionised atoms of Hydrogen and Oxygen. This causes a high temperature plasma in the immediate surrounding of the arc, of about 7,000°F, which is composed of highly ionised H, O and C atoms.

A number of chemical reactions then occur within or near the plasma, such as: the formation of the H₂O₂ molecule; the burning of H and O into H₂O; the burning of C and O into CO; the burning of CO and O into CO₂, and other reactions. Since all these reactions are highly exothermic, they result in the typical, very intense glow of the arc within water, which is bigger than that of the same arc in air. The resulting gases cool down in the water surrounding the discharge, and bubble to the surface, where they are collected with various means. According to numerous measurements conducted at various independent laboratories, the combustible gas produced with the above process essentially consists of 45%-48% H₂, 36%-38% CO, 8%-10% CO₂, and 1%-2% O₂, the remaining gas consisting of parts per million of more complex molecules composed by H, O and C.

This process produces an excellent combustible gas because the combustion exhausts meet all current EPA requirement without any catalytic converter at all, and without the highly harmful carcinogenic pollutants which are contained in the combustion exhausts of gasoline, diesel, natural gas and other fuels of current use.

Despite the indicated excellent combustion characteristics, and despite research and development conducted by inventors for decades, the technology of the combustible gas produced by an underwater arc between carbon electrodes has not reached industrial maturity until now, and no equipment producing said combustible gas for actual practical usages is currently sold to the public in the U.S.A. or abroad, the only equipment currently available for sale being limited to research and testing. The sole equipment currently sold for public use produce different gases, such as Brown's gas which is not suitable for use in internal combustion engines because it implodes, rather than explodes, during combustion.

The main reason for lack of industrial and consumer maturity is the excessively short duration of the carbon electrodes, which requires prohibitive replacement and services. According to extensive, independently supervised, and certified measurements, the electrodes are typically composed of solid carbon rods of about 3/8 inch (9 mm) in diameter and about 1 foot length. Under 14 Kwh power input, said electrodes consume at the rate of about one and one quarter inch (32 mm) length per minute, requiring the halting of the operation, and replacement of the electrodes every ten minutes.

The same tests have shown that, for 100 Kwh power input, said electrodes are generally constituted by solid carbon rod of about 1 inch diameter and of the approximate length of one foot, and are consumed under a continuous underwater arc at the rate of about 3 inch length per minute, thus requiring servicing after 3 to 4 minutes of operation. In either case, current equipment requires servicing after only a few minutes of usage, which is unacceptable on industrial and consumer grounds for evident reasons, including increased risks of accidents for very frequent manual operations in a piece of high current equipment.

An additional insufficiency of existing equipment is the low efficiency in the production of said combustible gas, which efficiency will from now on be referred to as the ratio between the volume of combustible gas produced in cubic feet per hour (cfh) and the real input power per hour (Kwh). For instance extensive measurements have established that pre-existing equipment has an efficiency of 2-3 cfh/Kwh. Yet another insufficiency of existing equipment is the high carbon dioxide content in the gas produced. Carbon dioxide is the gas responsible for the greenhouse effect. In fact, prior to combustion the gas has a CO₂ content of 8%-10% with a corresponding content after combustion of about 15% CO₂, thus causing evident environmental problems.

SUMMARY OF THE INVENTION

In view of the foregoing disadvantages inherent in the known types of traditional equipment for the production of combustible and non-polluting gases now present in the prior art, the present invention provides improved durable and efficient equipment for the production of a combustible and non-polluting gas from underwater arcs and the method of production.

As such, the general purpose of the present invention, which will be described later in greater detail, is to provide new, improved, durable and efficient equipment for the production of a combustible and non-polluting gas from underwater arcs and the method for achieving this, a method which has all the advantages of the prior art and none of the disadvantages.

To attain this, the present invention essentially comprises of a new and improved system for producing a clean burning combustible gas from an electric arc generating plasma under water. First provided is an electrically conductive anode fabricated of tungsten. The anode is solid in a generally cylindrical configuration with a diameter of about one inch and a length of about three inches. Next provided is a generally Z-shaped crank of a electrically conductive material. The crank has a linear output end supporting the anode. The crank also has a linear input end essentially parallel with the output end. A transverse connecting portion is located between the input and output ends.

An electrically conductive cathode is next provided. The cathode is fabricated of carbon. The carbon is in a hollow tubular configuration with an axis. The cathode has a supported end and a free end. The cathode has a length of about 12 inches and an internal diameter of about 11.5 inches and an external diameter of about 12.5 inches. A motor is next provided. The motor has a rotatable drive shaft. The drive shaft has a fixed axis of rotation. The motor is coupled to the input end of the crank and is adapted to rotate the crank to move the output end and anode in a circular path of travel. The circular path of travel has a diameter of about twelve inches with the anode located adjacent to the free end of the cathode. In this manner the anode and the arc are continuously moved around the cathode and away from the plasma created by the arc.

Next provided is an axially shifted support. The support is in a circular configuration to receive the supported end of the cathode and to move the cathode axially toward the anode as the carbon of the cathode is consumed during operation and use. Next provided is a water tight container for the anode, cathode, crank and support. A quantity of water is provided within the tank, sufficient to submerge the anode and the cathode. Next provided is an entrance port in the container. The entrance port functions to feed water and a carbon enriched fluid into the container to supplement the carbon and water lost from the container during operation and use. Next provided is a source of potential. The source of potential couples the anode and the cathode. In this manner an electrical arc is created between the anode and the cathode with a surrounding plasma for the production of gas within the water. The gas will then bubble upwards and collect above the water. Last provided is an exit port for removing the gas which results from the application of current from the source of potential to the anode and the cathode while the anode is rotating and the cathode is shifting axially.

This broad outline indicates the more important features of the invention in order that the detailed description which follows may be better understood and in order that the present contribution to the art may be better appreciated. There are, of course, additional features of the invention that will be described and which will form the subject matter of the claims made.

In this respect, before explaining at least one embodiment of the invention in detail, it is to be understood that the invention is not limited in its application to the details of construction and to the arrangements of the components set forth in the following description or illustrated in the drawings. The invention is capable of other embodiments and of being practised and carried out in various ways. Also, it is to be understood that the phraseology and terminology employed here are for the purpose of descriptions and should not be regarded as limiting the scope of this invention.

It is another object of the present invention to provide new and improved durable and efficient equipment for the production of a combustible and non-polluting gas from underwater arcs and method therefor which may be easily and efficiently manufactured and marketed on a commercial basis.

Lastly, it is an object of the present invention to provide a new and improved system for producing a clean burning combustible gas comprising an electrically conductive first electrode, an electrically conductive second electrode, a motor coupled to the first electrode and adapted to move the first electrode with respect to the second electrode to continuously move the arc away from the plasma created by the arc, and a water-tight container for the electrodes with a quantity of water within the tank sufficient to submerge the electrodes.

These together with other objects of the invention, along with the various novel features which characterise the invention, are pointed out particularly in the claims section of this disclosure. For a better understanding of the invention, its operating advantages and the specific objects attained by its uses, reference should be made to the accompanying drawings and descriptive matter in which there is illustrated preferred embodiments of the invention.

BRIEF DESCRIPTION OF THE DRAWINGS

The invention will be better understood and objects other than those set forth above will become apparent when consideration is given to the following detailed description thereof. Such description makes reference to the annexed drawings wherein:

Fig.1 and **Fig.2** are illustrations of prior art equipment for the fabrication of a pollutant-free combustible gas produced by an electric arc under water constructed with prior art techniques.

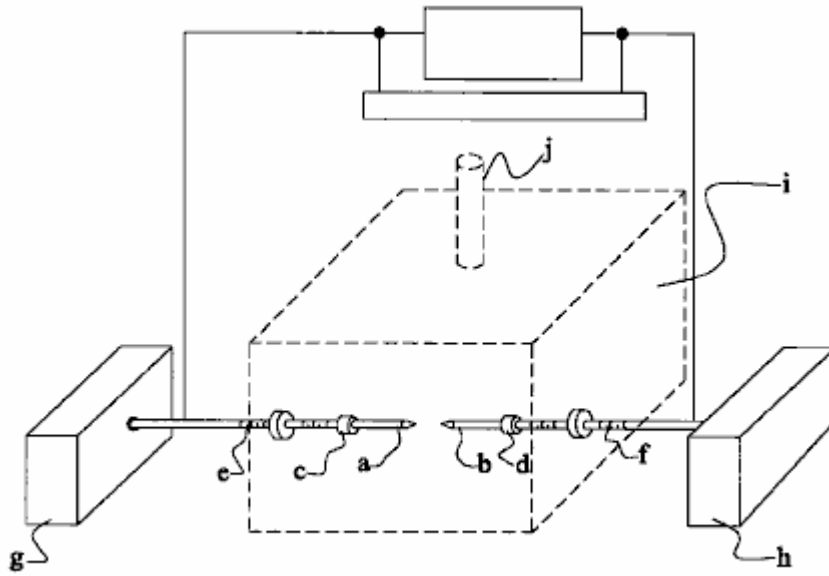

FIG. 1

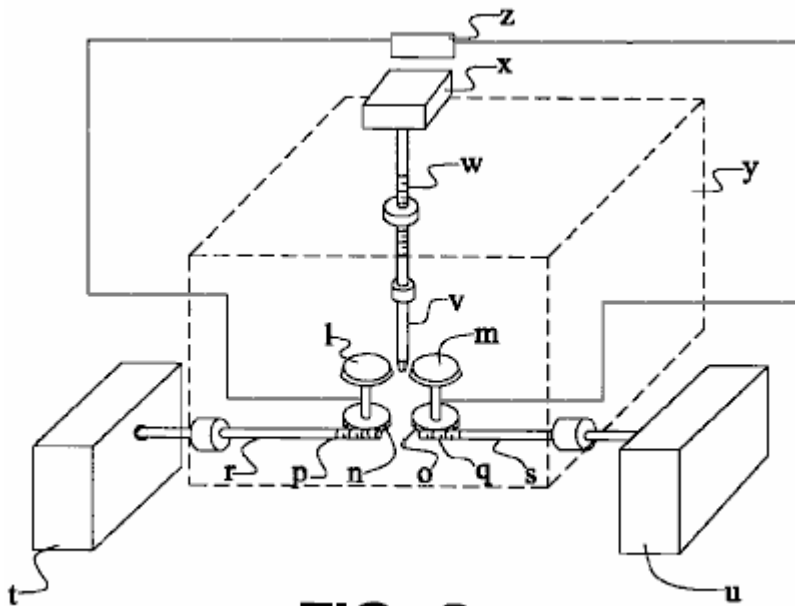

FIG. 2

Fig.3 is a schematic diagram depicting the principles of the present invention.

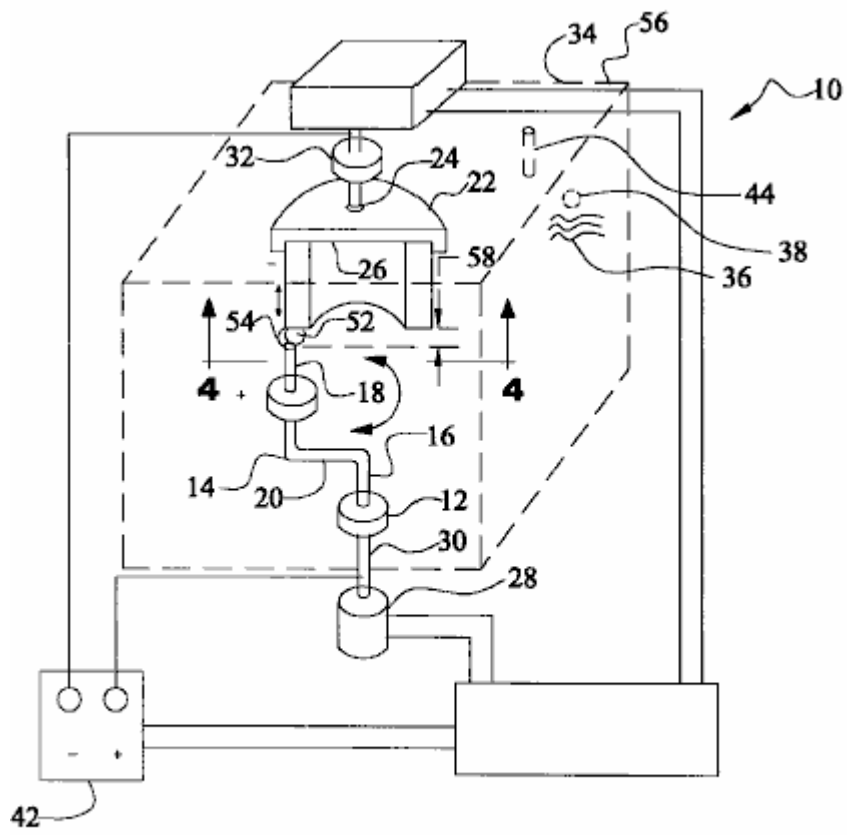

FIG. 3

Fig.4 is a schematic diagram of a partial sectional view taken along line 4--4 of Fig.3, depicting an additional embodiment of the present invention.

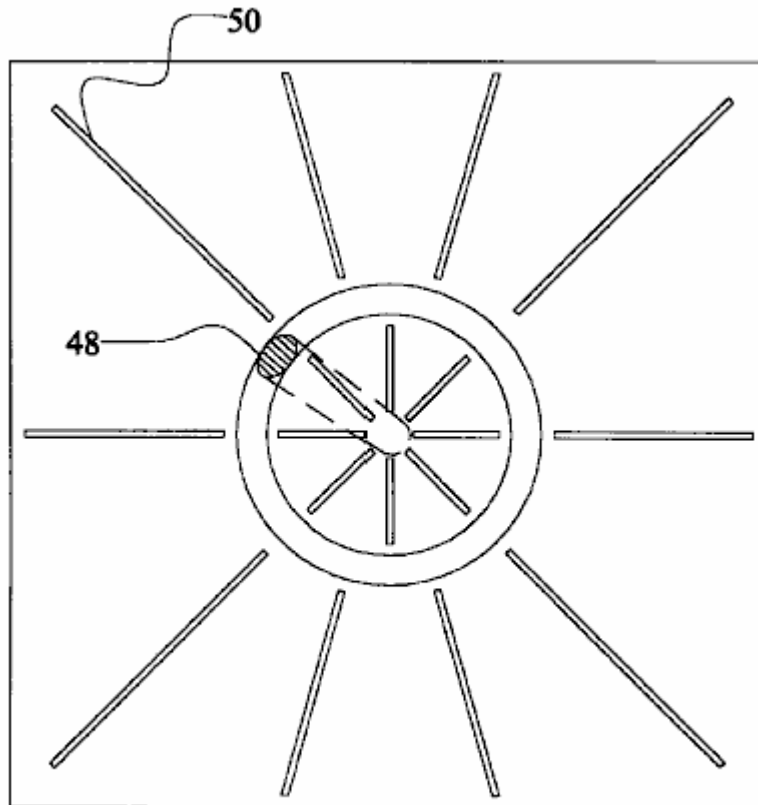

FIG. 4

The same reference numerals refer to the same parts throughout the various Figures.

DESCRIPTION OF THE PREFERRED EMBODIMENT

With reference to **Fig.1**, a typical embodiment of the electrodes of current use for the production of a combustible gas from underwater arcs is that in which one or more pairs of solid carbon rods are immersed within the selected liquid head-on along their cylindrical symmetry axis. The activation of the arc first requires the physical contact of the tips of the two rods, with consequential large surge of electricity due to shorting, followed by a retraction of the electrodes up to the arc gap, which is typically of the order of 1/16 inch (1.5 mm) depending on the input power. The components of such embodiment include:

- a, b: carbon electrodes
- c, d: holder of a & b
- e, f: screws for advancement of a & b
- g, h: mechanism for the advancement of a & b
- i: reaction chamber
- j: exit of combustible gas from chamber

Numerous alternatives to the above typical embodiment have been invented. For instance, in the U.S. Pat. No. 603,058 (H. Eldridge, 1898) one can see a variety of configurations of the electrodes, including rod shaped anodes and disk-shaped cathodes. As a further example also with reference to Fig.1, the embodiment of U.S. Pat. No. 5,159,900 (W. A. Dammann and D. Wallman, 1992) and U.S. Pat. No. 5,417,817 (W. A. Dammann and D. Wallman, 1995), essentially consists of the preceding geometric configuration of the electrodes, complemented by a mechanism for the inversion of polarity between the electrodes, because the cathode experiences the highest consumption under a DC arc, while the anode experiences a much reduced consumption. Even though innovative, this second embodiment also remains manifestly insufficient to achieve the duration of the electrodes needed for industrial maturity, while adding other insufficiencies, such as the interruption of the arc at each time the polarities are inverted, with consequential loss of time and efficiency due to the indicated electrical surges each time the arc is initiated.

As an additional example, and with reference to **Fig.2**, the mechanism of the U.S. Pat. No. 5,792,325 (W. H. Richardson, Jr., 1998), has a different preferred embodiment consisting of one or more pairs of electrodes in

the shape of carbon disks rotating at a distance along their peripheral edges, in between which an electrically neutral carbon rod is inserted. This rod causes the shorting necessary to activate the arc, and then the maintenance of the arc itself. This latter mechanism also does not resolve the main problem considered here. In fact, the neutral carbon rod is consumed at essentially the same rate as that of the preceding embodiments. In addition, the mechanism has the disadvantage of breaking down the single arc between two cylindrical electrodes into two separate arcs, one per each the two couplings of the conducting disk and the neutral rod, with consequential reduction of efficiency due to the drop of voltage and other factors. Numerous means can be envisaged to improve the life of carbon electrodes, such as mechanisms based on barrel-type rapid replacements of the carbon rods. These mechanisms are not preferred here because the arc has to be reactivated every time a rod is replaced, thus requiring the re-establishing of the arc with physical contact, and consequential shortcomings indicated earlier. The components of such embodiment include:

- l, m: carbon disk electrodes
- n, O: gear rotating l & m
- p, q: side gear for rotating n & o
- r, s: shaft of gears p & q
- t, u: mechanism for rotating shafts r & s
- v: electrodes neutral vertical rod
- w: advancement of v
- x: mechanism for advancement of v
- y: reactor chamber
- z: electrical power mechanism

This inventor believes that the primary origin of the insufficiency considered here, rests with the carbon rods themselves, which are indeed effective for underwater welding, but are not adequate for the different scope of producing a combustible gas from underwater arcs.

With reference to **Fig.3**, this invention specifically deals with equipment which solves the insufficiency considered here, by achieving the duration of operation desired by the manufacturer, while sustaining a continuous arc without interruptions for the entire desired duration. For the case of large industrial production of this combustible gas with electrical energy input of the order of 100 Kwh, a representative equipment of this invention essentially consists of:

- 1) One or more arcs produced by a DC current as typically available in commercially sold power units;
- 2) One or more anodes made of solid rods of about 1 inch in diameter and about 2 inches in length and composed of a high temperature conductor, such as Tungsten or ceramic. Extensive and diversified experiments have established that the consumption of an anode composed of ordinary Tungsten is minimal, and definitely of the order of several weeks of operation.
- 3) One or more carbon-based cathodes in the configuration of a large hollow rod geometrically defined as a cylinder with the same thickness of the anode, but with a radius and length selected to provide the desired duration. This cathode performs the vital function of becoming incandescent in the immediate vicinity of the arc, thus releasing carbon to the plasma.

More specifically, and with reference to **Fig.3** and **Fig.4**, the present invention essentially comprises a new and improved system **10** for producing a clean burning combustible gas from an electric arc generating plasma under water. First provided is an electrically conductive anode **12** fabricated of tungsten. The anode is solid in a generally cylindrical configuration with a diameter of about one inch and a length of about three inches.

Next provided is a generally Z-shaped crank **14** of a electrically conductive material. The crank has a linear output end **16** supporting the anode. The crank also has a linear input end **18** essentially parallel with the output end. A transverse connecting portion **20** is located between the input and output ends.

An electrically conductive cathode **22** is next provided. The cathode is fabricated of carbon. The carbon is in a hollow tubular configuration with an axis. The cathode has a supported end **24** and a free end **26**. The cathode has a length of about 12 inches and an internal diameter of about 11.5 inches and an external diameter of about 12.5 inches.

A motor **28** is next provided. The motor has a rotatable drive shaft **30**. The drive shaft has a fixed axis of rotation. The motor is coupled to the input end of the crank and is positioned so as to rotate the crank and move the output end and anode in a circular path of travel. The circular path of travel has a diameter of about twelve inches with the anode located adjacent to the free end of the cathode. In this manner the anode and the arc are continuously moved around the cathode and away from the plasma created by the arc.

Next provided is an axially shifted support **32**. The support is in a circular configuration to receive the supported end of the cathode and to move the cathode axially toward the anode as the carbon of the cathode is consumed during operation and use.

A water-tight container **34** for the anode, cathode, crank and support is next provided. A quantity of water **36** is provided within the tank sufficient to submerge the anode and the cathode.

An entrance port **38** is provided in the container. The entrance port functions to feed water and a carbon enriched fluid into the container to supplement the carbon and water lost from the container during operation and use.

Next provided is a source of potential **42**. The source of potential couples the anode and the cathode. In this manner an electrical arc is created between the anode and the cathode with a surrounding plasma for the production of gas within the water. The gas will then bubble upwardly to above the water.

Lastly provided is an exit port **44** for the gas resulting from the application of current from the source of potential to the anode and the cathode while the anode is rotating and the cathode is shifting axially.

Fig.4 is a cross-sectional view taken along line 4--4 of Fig.3, but is directed to an alternate embodiment. In such an embodiment, the anode **48** is wing shaped to cause less turbulence in the water when moving. In addition, various supports **50** are provided for abating turbulence and for providing rigidity.

Again with reference to **Fig.3**, the anode rod is placed head-on on the edge of the cylindrical cathode and is permitted to rotate around the entire periphery of the cylindrical edge via an electric motor or other means. (The inverse case of the rotation of the cathode cylinder on a fixed anode rod or the simultaneous rotation of both, are equally acceptable, although more expensive for engineering production). Extensive tests have established, that under a sufficient rotational speed of the anode rod on the cylindrical cathode of the order of 100 r.p.m. or thereabouts, the consumption of the edge of the cathode tube is uniform, thus permitting the desired continuous underwater arc without the interruptions necessary for the frequent cathode rod replacements in the pre-existing configurations.

For the case of smaller electrical power input the above equipment remains essentially the same, except for the reduction of the diameter of the non-carbon based anode and of the corresponding thickness of the carbon-based cylindrical cathode. For instance, for 14 Kwh power input, the anode diameter and related thickness of the cylindrical cathode can be reduced to about 3/8 inch.

The above new equipment does indeed permit the achievement of the desired duration of the electrodes prior to servicing. As a first illustration for industrial usage, suppose that the manufacturer desires an equipment for the high volume industrial production of said combustible gas from about 100 Kwh energy input with the duration of four hours, thus requiring the servicing twice a day, once for lunch break and the other at the end of the working day, as compared to the servicing only after a few minutes of use for the pre-existing equipment.

This invention readily permits the achievement of this duration with this power input. Recall that carbon rods of about 1 inch in diameter are consumed by the underwater arc from 100 Kwh at the speed of about 3 inches in length per minute. Numerous experiments have established that a cylindrical carbon cathode of 1 inch thickness, approximately one foot radius and approximately two feet in length, permits the achievement of the desired duration of 4 hours of continuous use prior to service. In fact, such a geometry implies that each 1 inch section of the cylindrical cathode is consumed in 6 minutes. Since 4 hours correspond to 240 minutes, the duration of four hours of continuous use requires forty 1 inch sections of the cylindrical cathode. Then, the desired 4 hours duration of said cathode requires the radius $R = 40/3.14$ or 12.7 inches, as indicated. It is evident that a cylindrical carbon cathode of about two feet in radius and about one foot in length has essentially the same duration as the preceding configuration of one foot radius and two feet in length. As a second example for consumer units with smaller power input than the above, the same duration of 4 hours prior to servicing can be reached with proportionately smaller dimensions of said electrodes which can be easily computed via the above calculations.

It is important to show that the same equipment described above also permits the increase of the efficiency as defined earlier. In-depth studies conducted by this inventor at the particle, atomic and molecular levels, here omitted for brevity, have established that the arc is very efficient in decomposing water molecules into hydrogen and oxygen gases. The low efficiency in the production of a combustible gas under the additional presence of carbon as in pre-existing patents is due to the fact that, when said H and O gases are formed in the plasma surrounding the discharge, most of these gases burn, by returning to form water molecules again. In turn, the loss due to re-creation of water molecules is the evident main reason for the low efficiency of pre-

existing equipment. The very reason for this poor efficiency is the stationary nature of the arc itself within the plasma, because under these conditions the arc triggers the combustion of hydrogen and oxygen originally created from the separation of the water.

The above described new equipment of this invention also improves the efficiency. In fact, the efficiency can be improved by removing the arc from the plasma immediately after its formation. In turn, an effective way for achieving such an objective without extinguishing the arc itself is to keep the liquid and plasma in stationary conditions, and instead, rapidly move the arc away from the plasma. This function is precisely fulfilled by the new equipment of this invention because the arc rotates continuously, therefore exiting the plasma immediately after its formation. Extensive experiments which were conducted, have established that the new equipment of this invention can increase the efficiency from the 2-3 cu. ft. per kWh of current embodiments to 4-6 cu. ft. per kWh.

It is easy to see that the same equipment of this invention also decreases the content of carbon dioxide. In fact, CO_2 is formed by burning CO and O, thus originating from a secondary chemical reaction in the arc plasma following the creation of CO. But the latter reaction is triggered precisely by the stationary arc within the plasma. Therefore, the removal of the arc from the plasma after its formation via the fast rotation of the anode on the cylindrical edge of the cathode while the liquid is stationary implies a decrease of CO_2 content because of the decrease of the ignition of CO and O.

Extensive experimentation has established that a rotation of 100 r.p.m of the anode over the edge of the cylindrical cathode of radius one foot decreases the content of carbon dioxide in the combustible gas at least by half, thus permitting a significant environmental advantage. The decrease of the CO_2 content also implies an increase of the efficiency, alternatively defined as energy content of the gas produced per hour (BTU/hr) divided by the real electric energy absorbed per hour (kWh). In fact, CO_2 is a non-combustible gas, thus having no meaningful BTU content. It is then evident that, since the total carbon content in the gas remains the same, the decrease of the non-combustible CO_2 is replaced in the gas by a corresponding increase of the combustible CO with the same carbon content, thus increasing the energy content of the gas for the same production volume of pre-existing inventions and for the same real power absorbed.

With reference to **Fig.3**, among various possible alternatives, a preferred embodiment of this invention for the high volume industrial production of a combustible gas from underwater arcs with about 100 Kwh real electrical energy essentially comprises:

- A) An enclosed reactor chamber **56** of the approximate dimensions 4 feet high, 3 feet wide and 3 feet long fabricated out of steel sheets or other metal of about 1/4 inch thickness, comprising in its interior the electrodes for the creation of the arc and having some means for the exiting of the gas produced in its interior as well as some means for the rapid access or servicing of the internal electrodes;
- B) The filling up of said chamber with a liquid generally consisting of water and/or water saturated with carbon rich water soluble substances;
- C) One or more anodes consisting of rods of about 1 inch in diameter and about 2 inches in length made of Tungsten or other temperature resistant conductor;
- D) One or more cylindrical shaped carbon cathodes with essentially the same thickness as that of the anodes and with radius and length selected for the desired duration;
- E) Electromechanical means for the rotation of the anode rod head-wise on the edge of the cylindrical cathode, or the rotation of the edge of the cylindrical cathode on a stationary anode rod, or the simultaneous rotation of both;
- F) Automation for the initiation of the arc and its maintenance via the automatic advancement of the carbon cathode, and/or the anode rod and/or both, in such a way to maintain constant the arc gap **58**.
- G) Fastenings of the cylindrical carbon cathode so as to permit its rapid replacement; various gauges for the remote monitoring of the power unit, combustible gas, liquid and electrodes; tank for the storage of the gas produced and miscellaneous other items.

An improved version of the above embodiment is conceived to minimise the rotation of the liquid because of drag due to the submerged rotation of the anode, with consequential return to the stationary character of the plasma **54** and the arc, consequential loss of efficiency and increase of CO_2 content for the reasons indicated above.

With reference to **Fig.4**, and among a variety of embodiments, this objective can be achieved by shaping the rotating anode in the form of a wing with minimal possible drag resistance while rotating within said liquid, and by inserting in the interior of the enclosed reactor chamber panels fabricated out of metal or other strong material with the approximate thickness of 1/8 inch, said panels being placed not in contact with yet close to the cathode and the anode in a radially distributed with respect to the cylindrical symmetry axis of the equipment and placed both inside as well as outside said cylindrical cathode. The latter panels perform the

evident function of minimising the rotational motion of said liquid due to drag created by the submerged rotation of the anode.

The remote operation of the equipment is essentially as follows:

- 1) The equipment is switched on with electric current automatically set at minimum, the anode rod automatically initiating its rotation on the edge of the cylindrical cathode, and the arc being open;
- 2) The automation decreases the distance between anode and cathode until the arc is initiated, while the amps are released automatically to the desired value per each given Kwh, and the gap distance is automatically kept to the optimal value of the selected liquid and Kwh via mechanical and/or optical and/or electrical sensors;
- 3) The above equipment produces the combustible gas under pressure inside the metal vessel, which is then transferred to the storage tank via pressure difference or a pump; production of said combustible gas then continues automatically until the complete consumption of said cylindrical carbon cathode.

As to the manner of usage and operation of the present invention, the same should be apparent from the above description. Accordingly, no further discussion relating to the manner of usage and operation will be provided.

With respect to the above description then, it is to be realised that the optimum dimensional relationships for the parts of the invention, to include variations in size, materials, shape, form, function and manner of operation, assembly and use, are deemed readily apparent and obvious to one skilled in the art, and all equivalent relationships to those illustrated in the drawings and described in the specification are intended to be encompassed by the present invention.

Therefore, the foregoing is considered as illustrative only of the principles of the invention. Further, since numerous modifications and changes will readily occur to those skilled in the art, it is not desired to limit the invention to the exact construction and operation shown and described, and accordingly, all suitable modifications and equivalents may be resorted to, falling within the scope of the invention

A METHOD AND APPARATUS FOR GENERATING PLASMA IN A FLUID

This patent application is for a most unusual system which produces a plasma discharge at room temperature and ambient pressure, using voltages as low as 350 volts and currents as low as 50 milliamps and among other things, it is capable of promoting the production of pharmaceuticals, production of nano-particles, the extraction of metals from liquids, low temperature sterilisation of liquid food, use in paper industries to decontaminate the effluent discharge, fragmentation or de-lignifications of cellulose; the removal of odour from discharging liquid in the food industries, and the treatment of fluid effluent. It is also a method of producing hydrogen gas at low cost.

ABSTRACT

A method and apparatus for generating plasma in a fluid. The fluid **3** is placed in a bath **2** having a pair of spaced electrodes **4, 6** forming a cathode and an anode. A stream of bubbles is introduced or generated within the fluid adjacent to the cathode. A potential difference is applied across the cathode and anode such that a glow discharge is formed in the bubble region and a plasma of ionised gas molecules is formed within the bubbles. The plasma may then be used in electrolysis, gas production, effluent treatment or sterilisation, mineral extraction, production of nanoparticles or material enhancement. The method can be carried out at atmospheric pressure and room temperature. The electrodes may carry means to trap the bubbles in close proximity. Partitions may be present between the electrodes.

DESCRIPTION

The invention relates to the provision and utilisation of a plasma formed in a fluid, and in particular to the provision and utility of a plasma formed within bubbles contained in an aqueous medium.

BACKGROUND

Plasma is an electrically conductive gas containing highly reactive particles such as radicals, atoms, plasma electrons, ions and the like. For example plasma may be formed when atoms of a gas are excited to high energy levels whereby the gas atoms lose hold of some of their electrons and become ionised to produce plasma.

Thermal plasma, including plasma arc is known. However plasma arc is associated with high power consumption, the rapid erosion of electrodes when used in electrolysis, the need for catalysts and high-energy loss due to the associated high temperatures.

Clearly therefore, it would be advantageous if a non-thermal plasma could be devised. This would enable the plasma to be used for a number of applications for which plasma is useful without the disadvantages associated with using a high temperature plasma arc.

SUMMARY OF THE INVENTION

According to a first aspect of the present invention, there is provided a method for generating plasma in a fluid, comprising the steps of providing a fluid, introducing and/or generating one or more gas chambers or bubbles within the fluid, whereby the chambers or bubbles are contained by the fluid, and treating the fluid such that a plasma is generated within the chambers or bubbles.

The fluid may be a liquid that is contained within liquid containment means.

The applicant has discovered that a plasma can be generated relatively easily within bubbles within an aqueous medium. This plasma causes dissociation of molecules and/or atoms which can then be treated and/or reacted to obtain beneficial reaction products and/or molecules and/or atoms.

The liquid container may be open to the atmosphere and the process may therefore be carried out at substantially atmospheric pressure. Alternatively the container may be placed inside a sealed reaction chamber, e.g. under

partial vacuum. This reduction in pressure can reduce the energy required to achieve a glow discharge within the bubbles passing over a cathode.

Importantly the process is not required to be carried out in a vacuum.

The plasma may be formed, for example, by applying a potential difference across electrodes which are immersed in the liquid.

Upon passing electricity of sufficient potential between two electrodes, the dielectric barrier associated with the bubble/chamber surface breaks down, with the accompanying formation of a glow discharge and plasma inside the gas bubbles or chambers. This enables plasma formation to be effected at very low voltages, current, temperature and pressure, as compared with known methods of plasma formation.

For example, typical voltages and currents associated with plasma arc are in the region of 5 KV and 200 A respectively, whilst in the present invention, a plasma may be provided with a voltage as low as 350 V and a current as low as 50 mA.

The formation of a glow discharge region adjacent said one electrode is caused by a dielectric breakdown in the bubbles surrounding the electrode. The bubbles have a low electrical conductivity and as a result there is a large voltage drop between the electrodes across this bubble region. This voltage drop accounts for a large portion of the overall voltage drop across the electrodes. The plasma is generated within the bubbles contained within the electrolyte. The liquid electrolyte acts as containment for the plasma within the bubbles.

When plasma discharge occurs, any water vapour inside the bubbles will experience plasma dissociation whereby H^+ , OH^- , O^- , H , H_3 , and other oxidative, reductive and radicals species are formed. The formation of charged plasma species will of course also depend on the chemical composition of the electrolyte.

In the present invention, the voltage needed for plasma generation is much lower than plasma glow discharge generated under gas only conditions. For example experiments have demonstrated that plasma begins to occur at voltages as low as 350 V and the maximum voltage required should not exceed 3,000 V. This requirement is based on a current density of 1 to 3 Amp/cm² which can be achieved at the point of discharge whereby the current input ranges from 50 mA to about 900 mA.

Plasma can be created, according to the present invention, in a steady manner with a low voltage and current supply, which leads to an economy in power consumption.

The bubbles may contain precursor materials originating in the fluid, which is preferably a liquid, more preferably being an aqueous electrolyte. This material may have been transferred from the liquid to the bubbles by diffusion or evaporation.

Alternatively the precursor may be introduced directly into the bubbles from outside the system.

The step of generating bubbles within the aqueous medium may be accomplished by one or more of the following: electrolysis, ebullition, ultrasonic cavitations, entrainment, scattering, chemical reaction, dissociation by electrons and ion collisions or local heating or ebullition, hydraulic impingement, ultrasonic waves, laser heating, or electrochemical reaction, electrode heating, releasing of trapped gases in the liquid, and externally introduced gases or a combination of them.

Electrolysis bubbles may be generated by the electrode as a result of the potential differences applied across them, e.g. hydrogen bubbles liberated by the cathode or oxygen bubbles liberated by the anode. Ebullition bubbles may be generated by electrical heating in the region of the electrodes. The bubbles may be generated by direct electrical heating or by heating in proximity to the electrode by a moving wire or grid. Microwave heating and heating using lasers may also be used to generate ebullition bubbles.

Cavitation bubbles may be generated by using an ultrasonic bubble generator or a jet of fluid or a jet of a mixture of gas and liquid injected into the electrolyte in proximity to the electrode. Cavitation bubbles may also be generated by hydrodynamic flow of the electrolyte in proximity to the electrode. Scattering of gas in proximity to the electrode may also be used to generate bubbles.

Bubbles may also be generated by a chemical reaction which evolves gas as a reaction product. Typically such reactions involve thermal decomposition of compounds in the electrolyte or acid based reactions in the electrolyte. Bubbles may also be formed in the electrolyte by adding a frother to it.

Typically the generation of bubbles forms a bubble sheath around one electrode. The bubble sheath may have a thickness of anything from a few nanometres to say, 50 millimetres. Typically the bubble sheath may have a thickness of 1 mm to 5 mm. Further, it should be understood that the bubbles may not be homogeneous throughout the sheath.

Gas or vapour formed external to the container may be pumped or blown into the aqueous medium near the cathode.

Thus the composition of the plasma that is generated within the bubbles may be tailored to suit the application to which the plasma is being put and the bubbles may either be generated within the liquid from components within the liquid or introduced into the liquid from outside the containment means.

The bubbles can assume various sizes and shapes including a sheet form air gap or air pocket covering shrouding the electrodes or spread across the liquid medium in micro bubbles.

Liquid foam may also be considered to be bubbles or gas chambers for the purposes of the present invention. This is a highly concentrated dispersion of gas within a continuous interconnecting thin film of liquid. The gas volume can reach up to 80% of a contained area. Gas generated within or introduced to the reactor externally can also be encapsulated within a foaming agent to enable it to undergo plasma discharge treatment.

Gases trapped inside a thick liquid mist in a confined space are also considered to be gas containing bubbles, which contain the gases, and liquid vapours that provide the condition for generation of non-thermal plasma. The liquid may contribute one or more source materials for dissociation during the plasma discharge.

In practise, gas bubbles evolving near and shrouding an electrode in an electrolysis process create a dielectric barrier which prevents and slows down the flow of current. At the same time the dissolved gas or micro bubbles spread and diffuse in the liquid volume thereby creating a high percentage of void fractions (micro gas bubbles) which in turn increase the electric resistance whereby the voltage across the liquid medium is raised. When the voltage has increased sufficiently, gas trapped inside the bubbles undergoes non-equilibrium plasma transformation. At this point, dielectric breakdown occurs enabling resumption of current flow through the bubbles sheath or air pocket layer.

Any water molecules and atoms lining the gas and liquid interface of a bubble shell will also be subjected to the influence of the plasma to produce H^+ and OH^- and other radical species. Some of these neutralised atoms and molecules will transpire into the gas bubbles as additional gas that increases the size of the bubble. As such the bubbles pick up more liquid vapours before a next succession of plasma discharge. Such a cycle of such repetitive discharge can take place in a fraction of a second to several seconds depending on the make up of the electrode and reactor.

The step of generating bubbles within the aqueous medium may include adding a foaming agent to the aqueous medium such that bubbles are formed within foam. The foam bubbles are confined by an aqueous medium that is electrically conductive. The foam bubbles can vary widely in size down to a fraction of a millimetre.

The step of generating bubbles may include forming an aerosol mist. The gas within the aerosol mist broadly defines bubbles in the sense that there are volumes of gas between liquid droplets. These bubbles in the form of spaces between liquid drops function in a similar way to conventional bubbles within a liquid and a plasma is formed in this gas in the same way as described above.

An advantage of foam and aerosol mist is that it provides for good mixing of gaseous components within the mist and foam. The plasma is generated in the bubbles of the foam and aerosol mist in the same way that they are formed in an aqueous liquid, e.g. by passing electrical current between spaced electrodes within the foam or mist.

The step of forming a glow discharge in the bubble region may be achieved by increasing the potential difference across the electrodes above a certain threshold point.

The formation of a glow discharge and generation of plasma within the bubbles may be assisted by a pulsed or steady power supply, a magnetron field, ultrasonic radiation, a hot filament capable of electron emission, laser radiation, radio radiation or microwave radiation. The energy requirements may also be assisted by a combination of any two or more of the above features. These factors may have the effect of lowering the energy input required to reach the threshold potential difference at which glow discharge is formed.

In conventional electrochemical processes bubbles are regarded as undesirable. As a result concerted efforts are made to avoid the generation of bubbles during the operation of electrochemical cells. By contrast the process of the current invention deliberately fosters the formation of bubbles and utilises bubbles in proximity to the electrode

as an essential feature of the invention. The bubble sheath surrounding the electrode is essential to establishing a plasma region which then gives rise to the plasma deposition on the article.

Thus the plasma is formed within bubbles and the molecules and/or atoms that are ionised are surrounded by liquid which effectively provides a containment structure within which the plasma is contained. The liquid in turn generally opens to the atmosphere.

Plasma glow discharge can be fairly easily accomplished within the cell because the sheath of bubbles has the effect of causing a substantial proportion of the voltage drop to occur across the bubble sheath. It is concentrated in this area rather than a linear drop across the electrode space. This provides the driving force to generate plasma glow discharge and from there deposition of the ionic species.

The electrical charge is preferably applied in pulses, since this enables plasma production at lower voltages.

The fluid is preferably a liquid electrolyte, for example an aqueous medium, whereby in one preferred embodiment, the medium is water.

The electrolyte may comprise a carrier liquid and /or a source or precursor of the material to be ionised by the plasma.

When the liquid is water, charged plasma particles include species such as OH radicals, O^- and H^+ , -OH, O_2 and O_3 , which will react with the surrounding liquid.

Distilled water is known to be dielectric and non-conductive. It is however when water contains impurities such as dissolved minerals, salts and colloids of particles, whereby water becomes conductive, that ionisation and electrolysis can occur.

The method may further include adding an additive, such as an acidic or alkaline conductivity enhancing agent, to the aqueous medium to enhance this electrical conductivity such as organic salts or inorganic salts, e.g. KCl, $MgCl_2$, NaOH, Na_2CO_3 , K_2CO_3 , H_2SO_4 , HCl.

The method may include adding a surfactant to the aqueous medium for lowering the surface tension of the medium and enhancing the formation of bubbles, e.g. to stabilise bubble formation.

The electrolyte may further include additives in the form of catalysts for increasing the reaction of molecules and/or atoms produced in the plasma, additives for assisting the formation of bubbles, and additives for buffering the pH.

The method may further include cooling the electrolyte to remove excess heat generated by the plasma reaction and regulating the concentration of one or more components within the electrolyte.

The cooling may comprise drawing electrolyte from the bath pumping it through a heat exchanger, and then returning it to the bath.

Plasma creation, according to the present invention can be effected in the absence of extreme conditions, for example plasma according to the present invention may be provide under atmospheric pressure and at room temperature.

During plasma production according to the present invention, a shroud of bubbles preferably builds up and smothers around at least one of the electrodes, whereby electrical charge builds up in the bubble shroud thereby creating a dielectric barrier which impedes current flow, whereby electrical resistance in the fluid medium builds up so that voltage through the medium is raised to a degree such that gas within the bubbles is excited to an energy level at which a plasma is produced.

The method according to the present invention preferably comprises the further step of exposing the plasma to a material, which on contact with the plasma undergoes a chemical and/or physical change.

For example the plasma can be used to cause dissociation of toxic compounds and then break down the compounds and/or cause them to undergo reactions leading to innocuous reaction products.

The plasma produced according to the present invention, which will be referred to as 'under-liquid' plasma has the same physical and chemical properties as plasma produced according to known methods and accordingly also has the utility of such plasma.

The under-liquid plasma according to the present invention can create an active catalytic condition which facilitates gas and liquid interaction. As such, the plasma according to the present invention, may promote any reaction which takes place in a liquid medium, for example chemical reactions, the production of pharmaceuticals, production of nano-particles, the extraction of metals from liquid, low temperature sterilisation of liquid food, use in paper industries to decontaminate the effluent discharge, fragmentation or de-lignifications of cellulose; the removal of odour from discharging liquid in the food industries, and the treatment of fluid effluent. Material may be chemically modified by means comprising one or more of the following: ionisation, reduction, oxidation, association, dissociation, free radical addition/removal, whereby, optionally, following chemical modification, the material is removed.

The invention may be used to tackle existing problems. For example, water that has been used in industrial processes or used in some other way has to be treated to remove harmful components before it is returned to ground water. This is typically achieved by reacting the harmful components with other chemical components introduced to the water to form relatively harmless products. Many undesirable components are treated fairly effectively in this way.

However some harmful components within water are not capable of being treated in this fashion. This poses a problem as these harmful components, e.g. contaminants, need to be removed from the water before it is returned to ground water. One known way of treating some of these components is to use an electric arc process to break down these toxic chemicals. However an electric arc process requires a substantial amount of energy to arc between electrodes within the liquid and is therefore costly. In addition the number of chemicals that are able to be treated in this way is limited. A further limitation of these processes is that they often cause rapid consumption and degradation of electrode material. Applicant believes that this water could be better treated by the method of this invention.

Moreover, the electric arc method of providing plasma, applies a high voltage across closely spaced electrodes causing the break down and ionisation of molecules, and then a surge of electrical current between the electrodes.

Further, many metals or mineral occur naturally in the ground in the form of ores as mineral oxides. The minerals need to be reduced to useful minerals. Typically the reduction is carried out using pyrometallurgical techniques, e.g. such as are used in electric arc furnaces. These treatments are very aggressive and utilise enormous amounts of electrical energy. Clearly it would be advantageous if a simpler more streamlined and more energy efficient method of reducing a mineral oxide to a mineral could be devised. Applicant believes that this could be done by the method of this invention.

Yet further, the generation of electrical energy with fuel cells is seen as an exciting new area of technology. Such fuel cells utilise hydrogen as a fuel. Accordingly a relatively inexpensive source of this hydrogen as a fuel is required. Currently hydrogen is produced by solar cells. However the present invention could be used to provide such a source of hydrogen.

In one form of the current invention, the undesirable compounds may be deposited on an electrode, e.g. the cathode, as a layer or coating. The compound can then be removed from the liquid by simply removing it from the aqueous medium.

In another form, the undesirable component can be reacted with a chemical compound, e.g. within the plasma, to form a solid compound, e.g. a salt in the form of a precipitate, that settles out of the aqueous medium and can then be removed from the aqueous medium.

Typically the undesirable component will be toxic to animals or harmful to the environment. However components that are undesirable in other ways are also included within the scope of the invention.

Applicant envisages that this will be particularly useful for the removal of harmful heavy metals from waste water. It will probably also be useful for the treatment of contaminated gases. Such gases will be introduced to the aqueous medium in such a way that they form part of the bubbles passing over the cathode and then be treated as described above.

Another example is the extraction of a mineral, e.g. a metal, from its metal oxide, the method including: dissolving the mineral oxide in an aqueous medium and then subjecting it to the method described above according to the first aspect of the invention whereby a plasma is generated within bubbles passing over the cathode, and the plasma reduces the mineral oxide to the mineral per se.

The ozone which is formed in the plasma can then be reacted with hydrogen to form an innocuous compound such as water. The reduced mineral which is formed in the plasma, e.g. a metal, may be deposited on the cathode or else may be precipitated out as a solid in the container.

In the case of water, hydrogen and oxygen produced, travel to the anode and cathode and are preferably then removed. As such, the process according to the present invention is an economical, simple and effective way of producing hydrogen.

The hydrogen produced in this fashion may be used as fuel, e.g. in fuel cells for the generation of electricity. Applicant believes that hydrogen can be produced relatively inexpensively in this fashion. Fuel cell technology is currently receiving an increased level of acceptance looking for a cheap source of the supply of hydrogen.

According to another aspect of the present invention, there is provided the use of this 'under-liquid' plasma in one or more of the following: chemical and/or physical treatments of matter, electrolysis, gas production, in particular hydrogen gas production; water, fluid and/or effluent treatment; mineral extraction; sterilisation of drinking water and/or liquid food, production of nano-particles, the enhancement of material chemical and physical properties.

According to a further related aspect of the present invention there is provided an apparatus for providing a plasma comprising; a container in which a plasma is provideable, bubble trapping means, arranged within the container, for trapping gas bubbles at a predetermined location in the container and, plasma creation means, in association with the container, for creating a plasma from the gas within the bubbles.

The plasma creation means preferably comprise electrical discharge means which most preferably comprise a cathode and/or an anode.

The apparatus, in one preferred embodiment being an electrolysis cell, further preferably comprises bubble introduction and/or generating means, for introducing and/or generating bubbles in the container.

Furthermore, the apparatus preferably comprises one or more of the following: enhancing means for enhancing plasma formation and one or more non-conductive partitions arranged between the electrodes, whereby the enhancing means preferably comprise bubble trapping means most preferably associated with the electrodes and wherein the enhancing means may also comprise current concentrating means for concentrating the electrical current at a predetermined position in the container which can take the form of one or more channels arranged through one or more of the electrodes.

The electrodes may take any suitable form, for example the electrodes may be so profiled as to entrap/attract bubbles, in order to help gas bubbles being created or introduced to the discharging electrode to form a dielectric barrier by which the voltage can be raised whereby a suitable current density is provided directly by high input of current or passively created by a current concentrating arrangement, for example, by conducting the current through small holes on the electrodes or by reducing the discharge surface area of the electrodes whereby in the latter case, the electrodes may take the form of pins, wires, rods and the like.

For example, the cathode may be formed by a hollow tube with perforated holes therein, e.g. small perforated holes. The holes allow bubbles introduced into the tube to pass out of the tube into the aqueous medium. Alternatively a cathode may be made of wire mesh or have a roughened surface, e.g. to encourage the attachment of bubbles thereto to slow down the movement of the bubbles.

In one embodiment there are a plurality of cathodes spaced apart from each other and in parallel with each other, and a single rod-like anode, e.g. centrally positioned relative to the cathode.

The other electrode (non discharging) preferably has a larger surface area such than the discharging electrode.

The discharging electrode can either be cathode or anode depending on the application necessity.

In an experimental reactor the separating membrane, non-conductive partition, was nylon cleaning cloth having a tight matrix 0.5 mm thick. This semi-permeable membrane is capable of resisting the passage of oxygen and hydrogen ions through it in the aqueous medium, intermediate the anodes and cathodes thereby to maintain separation of oxygen and hydrogen produced in the plasma.

Most preferably, the apparatus according to the present invention is an electrolytic cell.

A known problem with carrying out electrolysis is that any gas/bubble build up in the electrolytic cell creates a barrier to the flow of current through the electrolyte, thereby impeding electrolysis, which increase in resistance in turn forces the required voltage up. As such, electrolytic cells require a great deal of energy and are often very large in order to effect dispersion of such gas/bubbles. However the present invention actively promotes such bubble build up, in order to effect plasma creation which the inventors have shown is effective in carrying out electrolysis.

DETAILED DESCRIPTION OF PREFERRED EMBODIMENTS OF THE INVENTION

A plasma formed in a fluid in accordance with this invention may manifest itself in a variety of forms. It will be convenient to provide a detailed description of embodiments of the invention with reference to the accompanying drawings. The purpose of providing this detailed description is to instruct persons having an interest in the subject matter of the invention how to put the invention into practice. It is to be clearly understood however that the specific nature of this detailed description does not supersede the generality of the preceding statements. In the drawings:

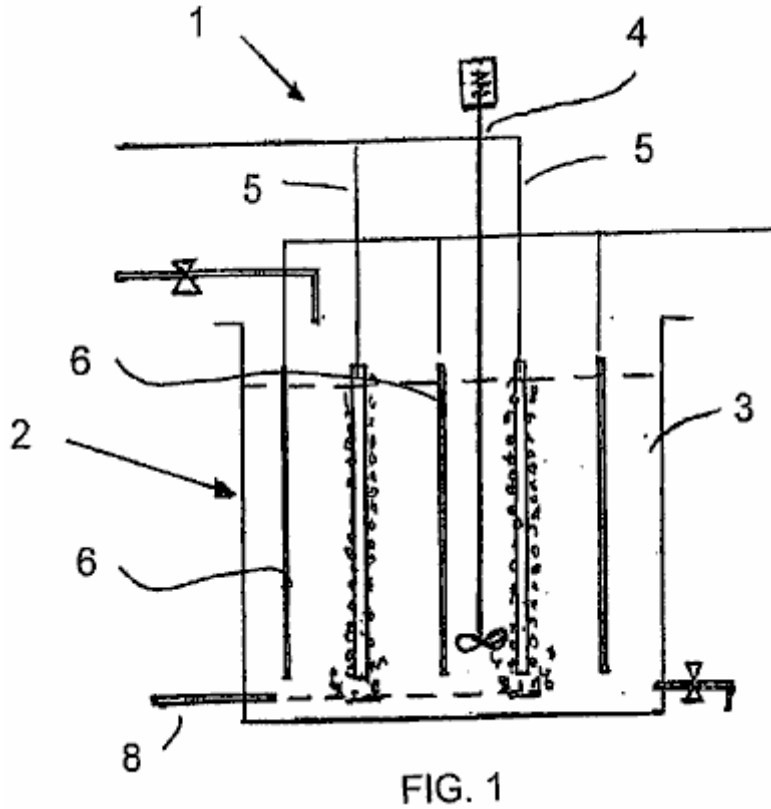

Fig.1 is a schematic sectional front view of apparatus for carrying out a method in accordance with the invention.

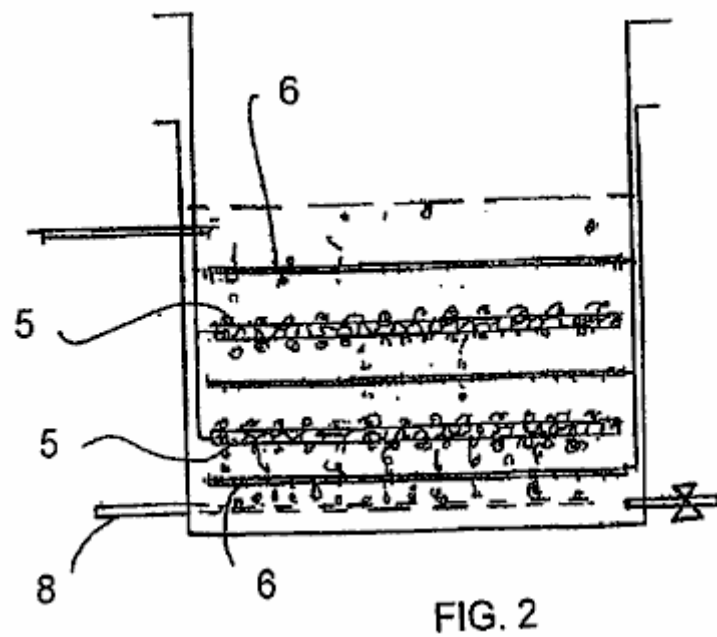

Fig.2 is a schematic sectional front view of a variation on the apparatus of Fig.1.

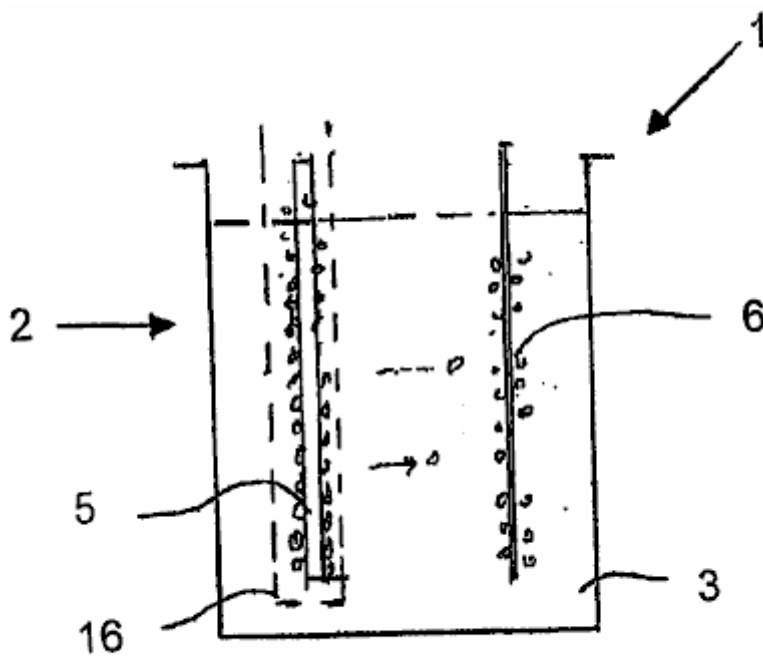

FIG. 3

Fig.3 is a schematic sectional front view of an apparatus in accordance with the invention suitable for producing hydrogen gas.

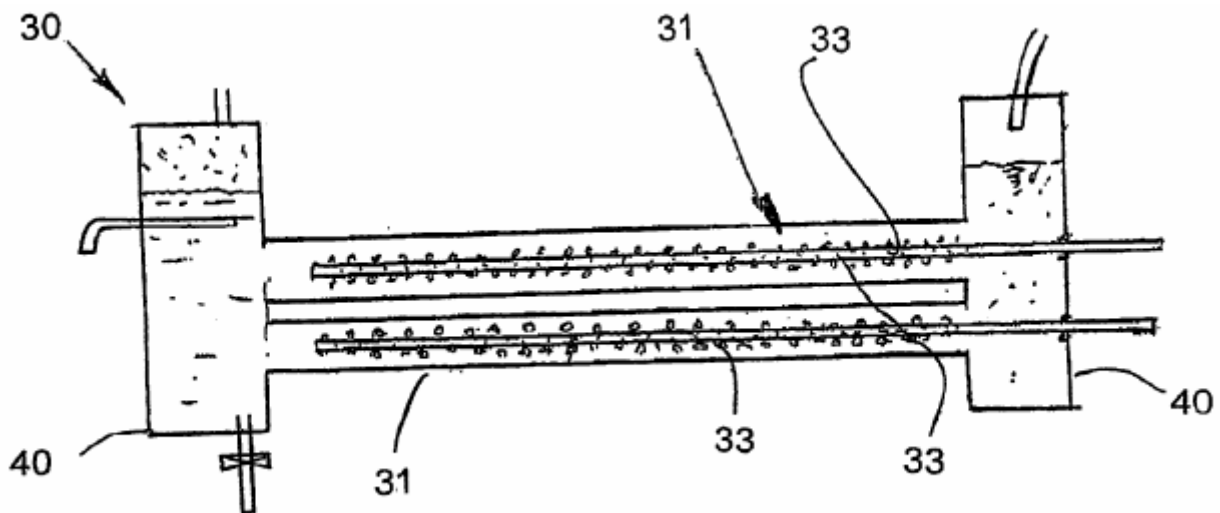

FIG. 4

Fig.4 is a schematic sectional front view of a tubular reactor carrying out a method in accordance with another embodiment of the invention.

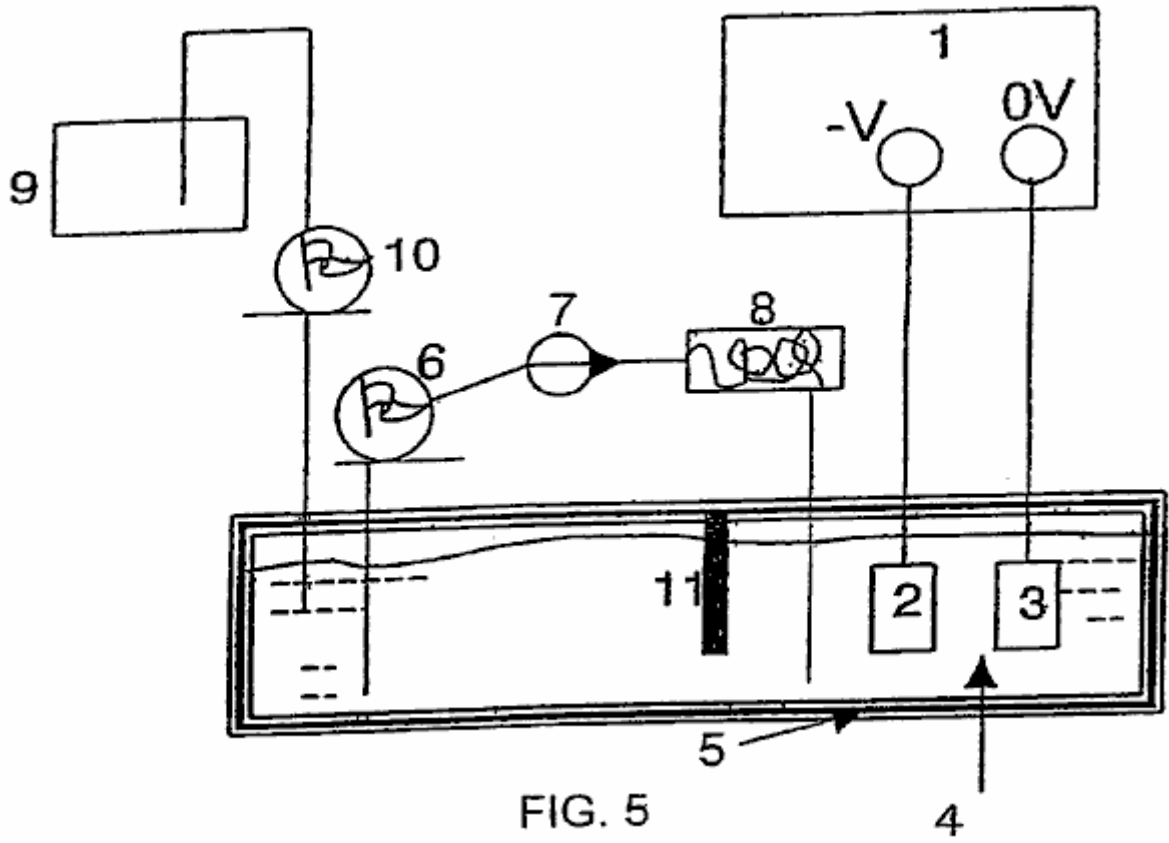

FIG. 5

Fig.5 is a schematic flow sheet of apparatus in the form of a cell for carrying out the invention.

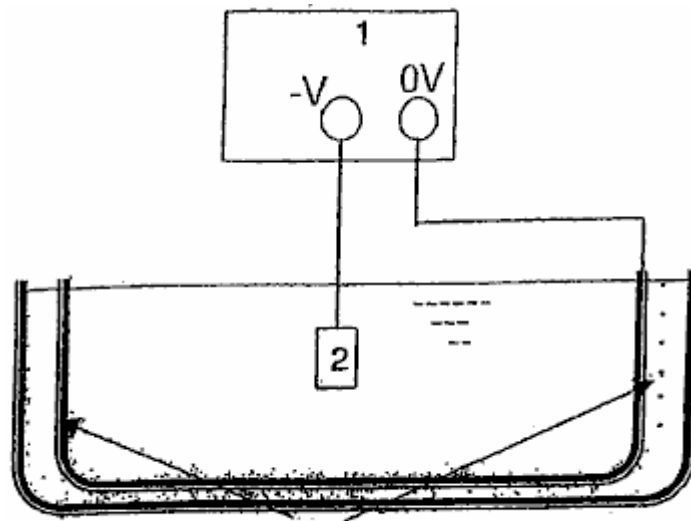

FIG. 6

Fig.6 is a schematic view of a bath for the cell of Fig.5 having an ultrasonic generator for generating bubbles.

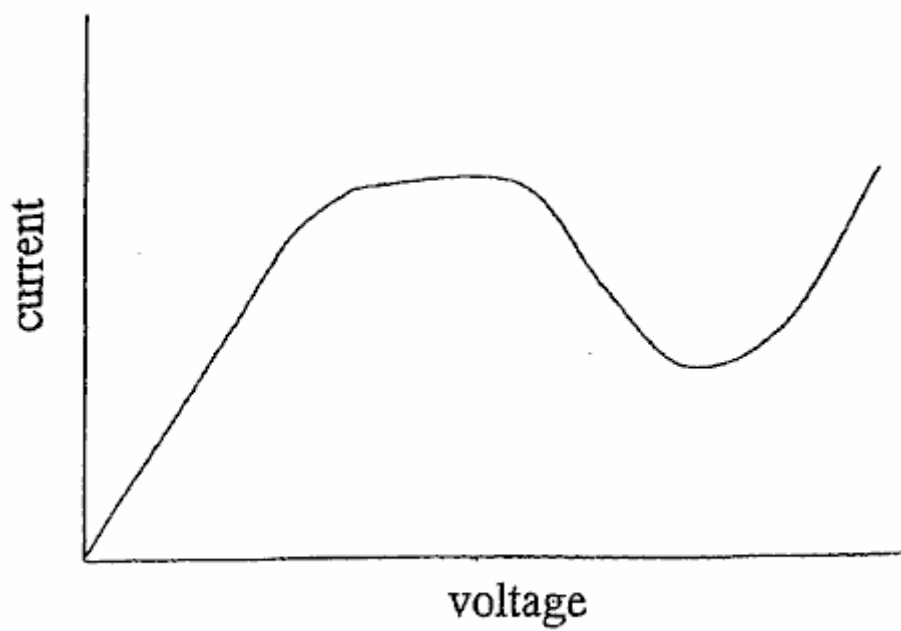

FIG. 7

Fig.7 is a schematic graph of current against voltage in an electrolytic cell.

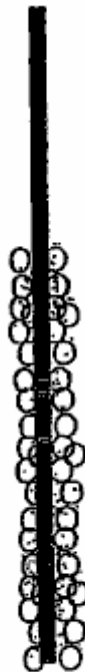

FIG. 8

Fig.8 shows the initial formation of a bubble sheath around the cathode due to the application of voltage across the electrodes.

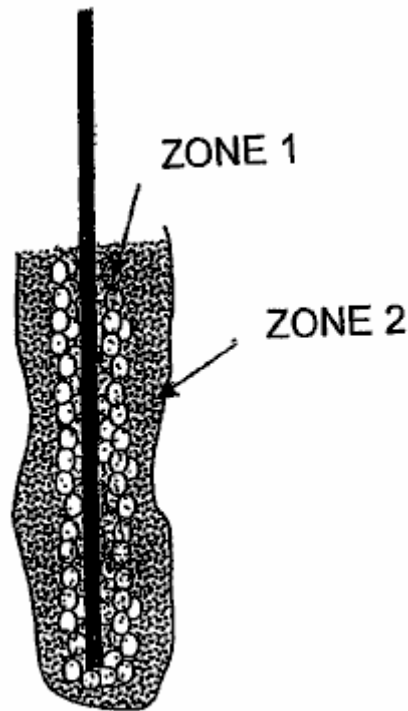

FIG. 9

Fig.9 shows the bubble sheath around the cathode during stable glow discharge within the cell, and

Figs.10-53 refer to further embodiments and experimental results in respect of the present invention.

The present invention relates to the production of non-thermal plasma contained in a liquid by generating corona discharge and or glow plasma discharge inside the bubbles or air pockets present in the liquid.

Upon passing electricity of sufficient potential through the liquid, electric breakdown of the dielectric bubble barrier results in the formation of plasma discharge inside the gas bubbles or pockets present in the liquid. In most cases glow discharge occurs near the electrodes but occasionally glow discharge is also observed away from the electrode.

The bubbles can be produced either by electrolysis, electrochemical reaction, heating of electrodes, releasing of trapped gases in the liquid, ultrasonic cavitations, laser heating, and externally introduced gases.

Bubbles produced by electrolysis of water contain hydrogen gas at the cathode and oxygen gas at the anode. Such bubbles can also contain other chemical vapours originating from the electrolyte or additives.

The liquid serves as an electrolyte which provides conductivity of electricity, the source material from which gases and vapour are produced for plasma dissociation to form, for example, reduction and oxidation, radicals and neutral species. The liquid also provides an active catalytic chemical environment for forming new compounds. It also serves as containment of gases in the form of bubbles or air pockets in which the non-thermal plasma discharge takes place.

In practise, gas bubbles evolving and shrouding the electrodes during electrolysis create a dielectric barrier which inhibits the flow of current.

At the same time the dissolved gas or micro bubbles spread and diffuse in the liquid volume create a high percentage of void fractions (micro gas bubbles) which also increase the electric resistance and so raise the voltage across the liquid medium.

When the voltage between two electrodes reaches a critical level, the gas trapped inside the bubbles undergoes non-equilibrium plasma transformation. This is also known as electric breakdown which enables the resumption of current flow through the bubble sheath or air pocket layer. In the case of water electrolysis, the production of hydrogen will then resume.

During plasma discharge, light emission may be observed in the bubbles in a sporadic or steady manner in short and continuous flashes near the surface of the electrodes and in the liquid medium.

Continuous light spots may also be observed in areas distanced from the electrodes where suspected small air bubbles are trapped and yet remain under the influence of strong electrical field.

The temperature in the electrolyte near the electrodes has been measured to be in the region of 50°C to about 90°C with an experiment running in water for 30 minutes, which indicates that the plasma is non-thermal plasma.

The temperature variation may be influenced by electrode geometry, electrolyte concentration, level of inception voltage and current density for the glow discharge. The temperature measured directly over the discharging electrode can reach over 200°C during reformation of methanol for example.

Configurations of electrodes, size, spacing, dielectric barrier coating, electrolyte temperature, current density, voltage and reactor geometry are factors influencing plasma formation.

A special structure and arrangement to retain gas or gas bubbles close to the electrodes provide favourable circumstances for the ready formation of a steady and cyclical plasma glow discharge with lower voltage and current input.

Electrode configurations can be in following forms: plate to plate, plate to pinned plate, dielectric coated plate to plate or pinned plate or both, wire mesh to plate, wire mesh to wire mesh or to perforated plate, wire or groups of wires in perforated cylinder tube, and tube in tube.

The electrode material may be sponge porous metal electrode, electrode covered with honeycomb non-conductive materials and porous ceramic filter to entrench gas or using non-conductive plate with drilled holes and gas traps that retain gas bubbles and concentrate the current density next to the electrode surface.

In general keeping the bubbles close to the surface of the electrodes can also be achieved by attaching a porous non-conductive nylon foam mattress and/or a honeycomb or porous ceramics slab of suitable thickness, so that the mobility of the bubbles is slowed down and at the same time the conduit for current flow is narrowed by a shading effect of the dielectric materials which in turn raises the current density locally.

For the same reason glass beads, plastic beads and beads of catalytic material i.e. TiO₂, graphite of suitable size can be placed between the electrodes in order to slow down the flow of bubbles.

A non-conductive, heat and corrosion electrode covering material, structured to retain and trap gas bubbles which also concentrates current density through small openings arranged through it whilst providing an adequate exposed electrode surface for electro-chemical and electrolysis reactions, improves the generation of steady and short cyclical reactions under-liquid plasma discharge.

Multiple layers of very fine stainless mesh, sandwiched between two plastic cover plates with small perforated holes, have produced a steady glow plasma. The void space created by the layered wire mesh provides a trap for air bubbles as well as enlarging the contact surface for electrochemical and electrolysis reaction.

In an experiment both vertical or horizontal electrodes were covered and bonded with non-conductive materials (plastic) with patterned perforations to trap gas bubbles while at the same time allowing for electrical contact of the electrodes through the perforations.

The electrode contact surface was enlarged underneath the shielding to increase gas production during electrolysis or heating. Current flow was concentrated through small holes of 1 to 3 mm leading to the trapped gas and bubbles, which underwent plasma transformation. Cyclical and steady plasma was observed with an input DC voltage ranging from 350V to 1900V and current ranging from 50 mA to 800 mA.

A non-conductive diaphragm, which does not restrict the free flow of ions and electrolyte, is placed between two opposite electrodes to prevent crossing of bubbles between two half electrolytic cells avoids re-mixing of the gases which have been separated by electrolysis.

A reactor may be so structured that the electrolyte is able to enter into the reactor through the separating membrane or opening form in the reactor to replenish the loss of electrolyte within the enclosed reactor.

There are other techniques which can be incorporated into the proposed invention for the enhancement of plasma generation such as pulsed power supply, RF power, microwaves, ultrasonic waves, magnetron field, and laser. Some of the above techniques may also be applied in pulsed form.

Ultrasonic cavitations in liquid (sonic-technology) will enhance the plasma formation and the catalytic reactions that benefit a number of under-liquid plasma applications.

The under-liquid plasma requires an input of DC or AC voltage in the range from 350V up to 3000V and current density ranging from 1 Amp to 3 Amp per cm^2 in dealing with a large range of liquid media. The specific voltage and current requirement for a given application depends very much on the chemical and physical properties of electrolytic liquid as well as those factors mentioned above.

The under-liquid plasma method according to the current invention, can operate at atmospheric pressure and ambient temperature. However, an external pressure less than one atmosphere or over one atmosphere with higher temperatures does not deter the generation of plasma in the bubbles. A higher temperature in the liquid also means more active gas molecules within the bubbles, which can benefit plasma formation.

Non-thermal plasma generated in a liquid according to the present invention, has advantages over known types of plasma discharge, for example in gas, under water plasma arc and pulse power electric discharge, these being:

It requires only simple electrolytic cells to be the reactor to perform such discharge. There is little erosion to the electrodes and wider range of electrode materials can be chosen such as stainless steel, graphite, aluminium and good conductive materials which are resistance to chemical erosion. The polarity of the electrode can be reverted if necessary to compensate the lost of electrode materials if so desired.

It works under one atmospheric pressure and ambient temperature. The liquid electrolyte will be primary source of materials for the chemical and physical reaction take part in the process. There are number of ways that bubbles can be produced within the electrolytic cell. Gas can also be introduced to the reactor where plasma catalytic and dissociation is taking place.

It is a low-temperature system as the plasma discharge is non-thermal. Any excessive or undesirable high temperature can be lowered by increasing the circulation rate of the liquid which can lose its temperature through heat exchange. Heat generated can be recovered as secondary energy.

The electrolyte (liquid) will serve as extension of the conducting electrodes in contact with the gases or vapour trapped inside the bubbles. The air gap between two electrodes is reduced to the thickness of the gas bubbles or air pocket which thus enables plasma discharge at a much lower voltage and current compared with other plasma discharge systems. Plasma glow discharge, according to the present invention, can be initiated under conditions of a voltage as low as 350V and the current ranging from 50 mA to 800 mA. Extra energy is not required in splitting the water molecules to transient bubbles as in the other underwater electrical discharge system which requires voltage not less than 5 to 6 KV, and very high current over 200 A in pulsed supply. Plasma discharge will also take place in gas pockets or bubbles away from the electrode as long as the electric field strength is sufficient to cause such discharge.

The electrolyte also serves as a confinement of gas generated within the system, or purposely introduced gas of known properties, instead of ordinary air which may lead to production of unwanted NOx for example. Noble gas such as argon is not necessary to enhance the initiation of glow discharge sometime required in the air discharge system.

The electrolyte also serves as a conductor and passage for the transportation of ionised species and transmission of electrons. The ionised atoms and molecules deriving from the electrolyte will be collected in their respective electrodes in the form of gas or material deposit. These ionised species are either serving as a reduction or oxidation agent in their respective half-cell. Since the gas ions produced during the discharge migrate to their respective poles to be collected individually, hydrogen gas and oxygen gas can be collected separately.

The gas and vapour molecules and atoms inside the bubble which undergo plasma glow discharge are ionised, excited or dissociated to produce the very active species for reduction, oxidation, and the forming of neutral or radical species which in turn react with the chemical elements present in the gas and liquid interface aligning bubbles wall. The large number of bubbles generated near the electrodes and in the nearby liquid, come into contact with a much larger volume of liquid and so provides effective treatment, breakdown, transformation of chemicals, organic matter or elements which have been targeted.

Liquid is a good medium for transmitting ultrasonic waves. Sonic-excitation is beneficial for the dissociation of materials and extermination of microbes and it aids the breakdown and local melting of colloidal solids during impact which also enhances the plasma oxide reduction process. The generated ultrasonic cavitations may be fully utilised to work in conjunction with the under-liquid plasma discharge. An ultrasonic cavity is micro in size and uniformly distributed in the entire liquid volume. The cavities are a high vacuum which contain liquid vapour and gas, and these favour plasma discharge. The high temperature and pressure reaching $10,000^\circ\text{K}$ and a

thousand times atmospheric pressure, produced on the collapsing phase of these cavities work is complementary to that of the electro discharge plasma. This enables under-liquid plasma discharge to spread further from the electrodes and be well distributed in the liquid volume which increases its overall effectiveness.

The electrolyte may also be in the form of a mixture, an emulsified liquid, a colloid, or foams encapsulating gas emissions either coming from the liquid or introduced externally. The emulsified liquid of an oil/water mixture and encapsulating gas of hydrocarbon fuel with the ultrasonic irradiation, will facilitate their reformation for hydrogen production.

Fine granular insoluble particles of mineral oxide such as aluminium, titanium, iron, silica etc. can be suspended in the form of colloid with the liquid which is then subjected to reduction with active ionic hydrogen atoms in a highly reactive plasma catalytic environment to become deoxidised and refined. This will be more so, with the assistance of sonic impedance. The Plasma glow discharge has also demonstrated the ability to dissociate soluble ionic metal compounds, whereby subsequently the positively charged metal ions will be segregated near the cathode electrode in the form of precipitation and plasma electroplating deposition.

The electrolyte may be a source of materials for thin-film deposition with the assistance of plasma glow discharge. In addition, nano size particles of certain compounds and elements i.e. metal hydride, oxide, pure metals, semi metals, organic, ceramic etc. can also be produced with the assistance of the under-liquid plasma discharge in conjunction with the ultrasonic cavitations mechanism, to cause breakdown and reformation of certain compounds. The highly catalytic, reactive and dissociation capacity of the glow discharge plasma, reforms and reconstitutes chemical elements and compounds from basic atoms or molecules to form nano particles. These include organic, inorganic, metallic and non-metallic materials such as silica, titanium carbon etc. This is also a very effective way to extract or remove heavy metals from a liquid by oxidising such as Hg to HgO; Cu, Zn, Cr etc. to form hydroxide precipitation and ionic metal solute to be deposited by the plasma electroplating process.

The under-liquid plasma creates a highly catalytic and reactive environment for chemical reactions which would not take place under normal circumstances. The reductive species i.e. H⁺ and oxidative radicals i.e. O⁻, O₃, H₂O₂, OH⁻ and other radical species produced in the electrolysis and plasma dissociation derived from the liquid itself. The sonic excitation action which enhances the effectiveness of plasma discharge can only be conducted spontaneously under and within liquid.

The under-liquid plasma technique, coupled with the sonic-excitation and electro-chemical action, creates an environment of localised high temperature up to 10,000^oK and pressure up to thousands of atmospheres which favour the generation of cold-fusion phenomena.

It is a low-energy system. Generally high voltage from 0.35 KV up to 3 KV with low current density rarely required more than 3 Amp/cm² will be needed to deal with a vast number of different types of the under-liquid plasma process. If other enhancement method is applied, the high voltage and current requirement will be further reduced.

It is a method for producing hydrogen, oxygen with water or other gases and material deposition with liquid containing chemical solute, other than the conventional exchange of ions. The molecules and atoms are being ionised, excited and subjected to dissociation to form ionised, radicals and neutral species by the influence of plasma discharge. The dissociated species can be produced near either anode or cathode electrodes. The ionised species are then attracted to their respective polarity to be neutralised to produce gas or deposition of materials. The dissociation of atoms or molecules are the result of electron collisions and a wide variety of dissociated species is produced which creates the reactive elements for reduction, oxidation, and highly catalytic environments that facilitate chemical reaction of those relatively stable compounds and elements.

No chemicals are needed as an additive in a decontamination process, of which chemicals, i.e. chlorine and ozone, could become a secondary source of pollution.

EXPERIMENTAL OBSERVATIONS

When sufficient micro bubbles originating from the electrode surface block the current flow, the voltage rises steadily until a point of voltage inception is reached whereby some micro bubbles begin experiencing glow discharge. This precedes an avalanche effect which spreads through other micro bubbles close by.

A massive light is then emitted in a flash with a sound of bursting bubbles. The light is yellow to orange in colour indicating plasma discharge in hydrogen gas at the cathode electrode. Soon after switching on the reactor, temperature in the electrode rises which contributes to the formation of vapour bubbles which in turn creates a large bubble environment full of water vapour whereby the next succession of plasma discharge takes place within a fraction of a second.

The features which enable the trapping of gas, the concentration of current density within a small region, and the continued replenishment of gas, are steady and a self-regulating voltage and current power supply, electrode spacing, electrode configuration and electrolyte concentration, all of which have a bearing on generating desirable steady, and short cycle plasma glow discharges.

The invention has a number of applications including:

Plasma assisted electrolysis for hydrogen generation.

Non-thermal plasma reformation of hydrocarbon and hydrogen rich compounds for the production of hydrogen.

Treatment of polluted and contaminated liquid waste containing chemical and heavy metal pollutants.

Treatment of polluted gas emission and removal of odours.

Sterilisation of drinking water and liquid foods.

Extraction and refinement of mineral from its oxide or oxide ores.

Production of nano particles.

Enhancement of a material's chemical and physical properties by plasma discharge irradiation in under-liquid conditions. This also favours the need of any plasma reaction and treatment under-liquid.

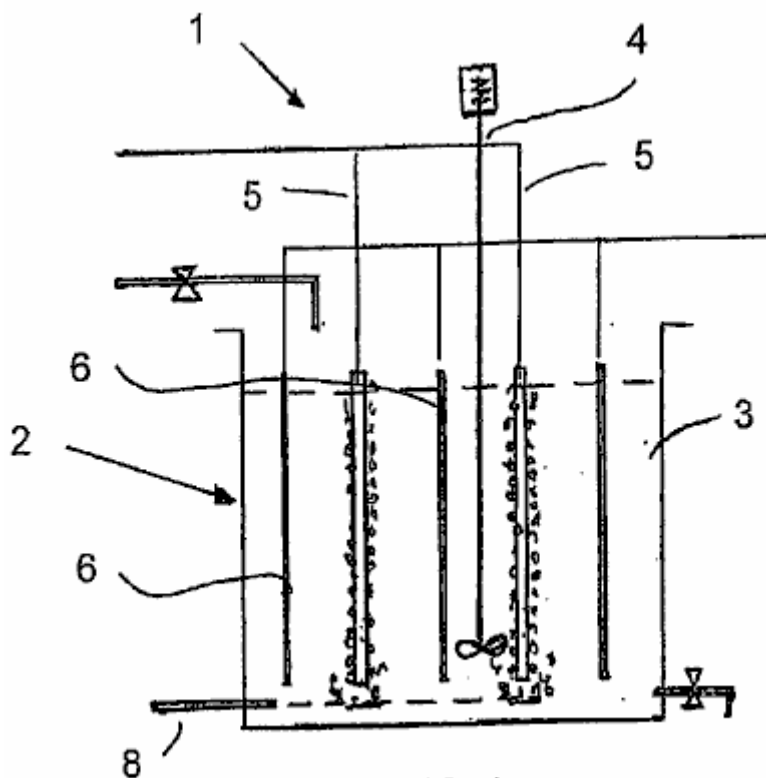

FIG. 1

Fig.1 illustrates a basic apparatus 1 for carrying out the method of the invention, namely, generating a plasma within bubbles formed adjacent to a cathode within an aqueous medium. The apparatus 1 comprises a liquid containment means in the form of an open rectangular tank 2 opening to the atmosphere and containing an aqueous liquid 3. A stirrer 4 for agitating the aqueous liquids in the tank 2.

Two spaced cathodes 5 are positioned in the tank 2 alternating with three anodes 6 projecting into the tank 2 and extending generally parallel to the cathodes 5. A bubble pipe 8 is positioned at the bottom of the tank 2 for introducing bubbles into the aqueous medium in proximity to each of the cathodes 5.

The application of a suitable potential difference across the anodes and cathodes leads to a glow discharge being formed and a plasma within the bubbles adjacent the cathode. This ionises the atoms and/or molecules within the bubbles and can be used to achieve a number of industrially and commercially useful objectives. For example, it can be used to generate hydrogen gas, one of its uses includes placement in a fuel cell to generate electricity. It can also be used to neutralise harmful compounds within the aqueous medium, e.g. originating in a liquid source or a contaminated gas and treating these harmful compounds. Finally, it can also be used to coat the surface of an article with a particular material.

Each of the cathodes is in the form of a perforated tube. At least one end of the tube is open and typically gas is introduced through such an open end. The side wall of the tube is perforated such that gas issues from the tube into the aqueous medium around the cathode. Alternatively, each of the anodes may be rod-like.

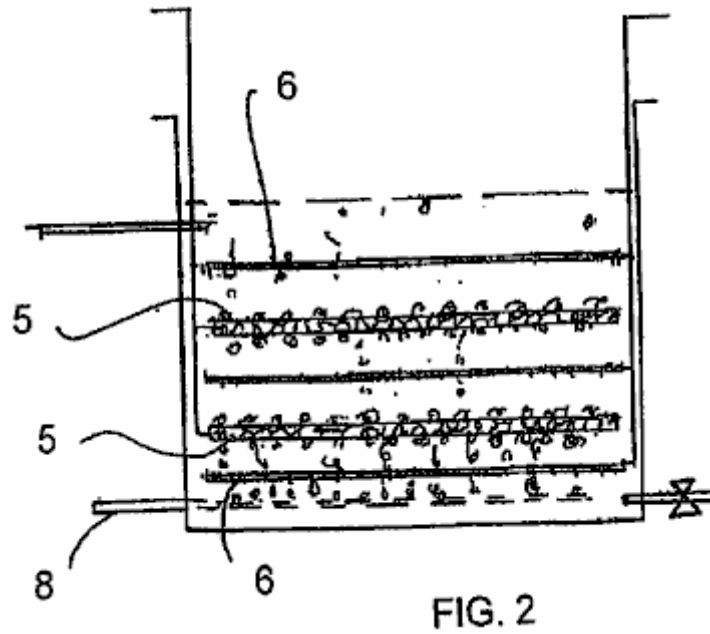

FIG. 2

Fig.2 illustrates a variation on the apparatus of **Fig.1**. This description will be confined to the difference between the **Fig.1** and **Fig.2** apparatuses. In **Fig.2** the electrodes extend horizontally with each cathode positioned between two vertically spaced anodes.

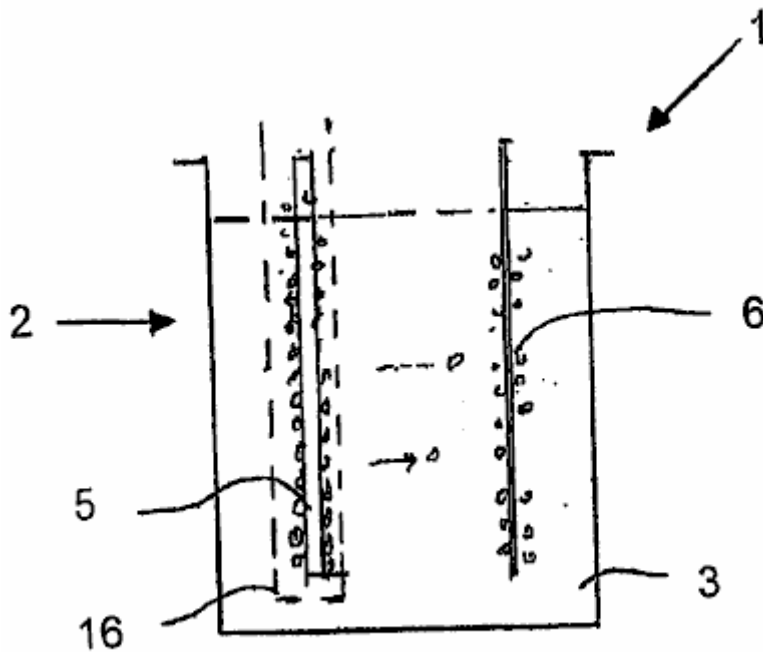

FIG. 3

Fig.3 illustrates an apparatus suitable for the generation of hydrogen. The tank contains an anode and a cathode spaced apart from each other. The electrodes are generally the same as those described above with reference to **Fig.1**. The cathode is surrounded by a semi-permeable membrane. Specifically the membrane is designed to resist the passage of hydrogen and oxygen bubbles through it. Hydrogen gas is formed from the combining the two neutralised hydrogen ions adjacent to the cathode and then is drawn off from the aqueous medium above the cathode and collected for use.

Similarly, oxygen gas is formed adjacent to the anode and this is also drawn off separately and collected for use. An advantage of this method for the formation of hydrogen fuel is that it consumes essentially less energy than other known methods, and as a result, will be a very attractive source of hydrogen for use in fuel cells.

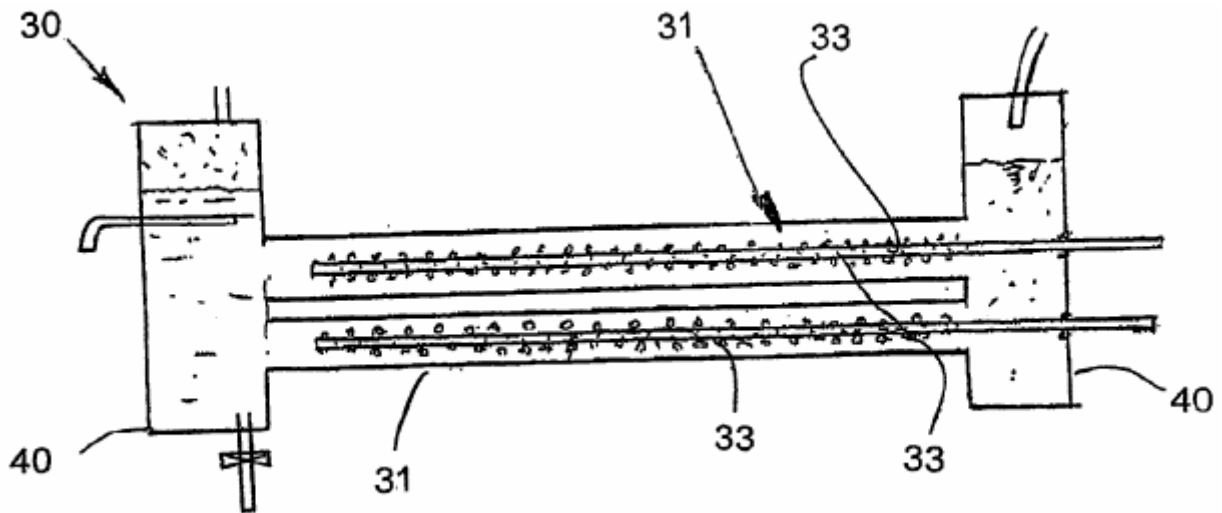

FIG. 4

Fig.4 illustrates a tubular reactor which is quite different to the tank 2 shown in the previous embodiment. The reactor 30 comprises a circular cylindrical body 31 with its longitudinal axis extending horizontally. A pair of electrodes 32, 33 extend longitudinally through the body, spaced in from the wall of the body 31. Each cathode 33 is formed by a perforated tube. By contrast, the anode is formed by the body 31. Thus the single anode 31 extends concentrically around the cathodes 33, positioned radially inwards from them. A gas, which ultimately forms the bubbles, is pumped into the cathodes, e.g. through their open ends, and then issues through the openings along the length of the cathodes 33.

Settling tanks are located at each end of the body 31. The settling tanks 40 permit gas to be separated from the liquid. The gas rises to the top of the tanks 40 from where it can be drawn off. The aqueous liquid can be drawn off through a drain point positioned below this level of aqueous medium in the tank 40. An aqueous medium can also be introduced into the apparatus, by passing it through an inlet into one of the tanks 40. Otherwise, the method of generating plasma in bubbles adjacent to the cathodes is very similar to that described above with reference to **Fig.1** to **Fig.3**.

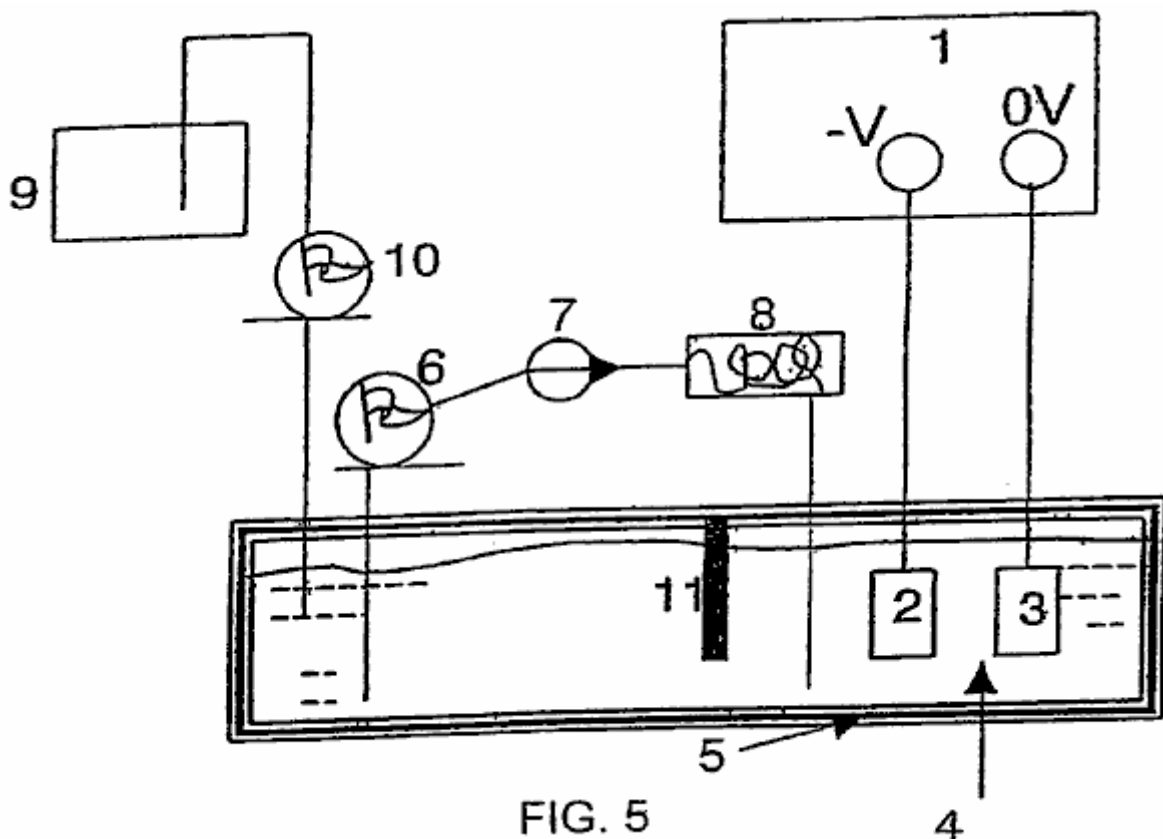

FIG. 5

In **Fig.5**, reference number 1 refers generally to apparatus in the form of a cell and associated components for carrying out a plasma electroplating process (PEP) in accordance with the invention. The cell 1 comprises

broadly, a liquid container in the form of a bath which is filled with an electrolyte which also forms part of the apparatus or cell. A pair of spaced electrodes are positioned in the bath, one being a cathode and the other being an anode. An electrical circuit is formed by electrically connecting up the anode and cathode to a power supply, e.g. a mains power supply. When the bath is being used, a potential difference is applied across the electrodes. A partition divides the bath into an electrode compartment and a circulating compartment. Electrolyte is drawn off the circulating compartment and pumped through a heat exchanger to cool it and then return it to the bath. This helps to keep the temperature of the electrolyte within a suitable range during operation. In addition a make-up tank is positioned adjacent the circulating compartment to replenish the level of electrolyte within the bath as and when required.

The apparatus also includes the means for producing a bubble sheath around the cathode. The bubbles can be generated by gas evolved at the cathode as a result of a cathodic electrochemical reaction. This is one of the ways in which the bubbles were generated in the experiments conducted by the applicant. There are however, alternative ways of generating the bubbles for the bubble sheath. One alternative way, is by boiling the solution (ebullition bubbles). Other ways of producing the bubbles are by cavitation generated by ultrasonic waves or by hydrodynamic flow. Entrainment bubbles can also be produced by a mixture of gas and liquids.

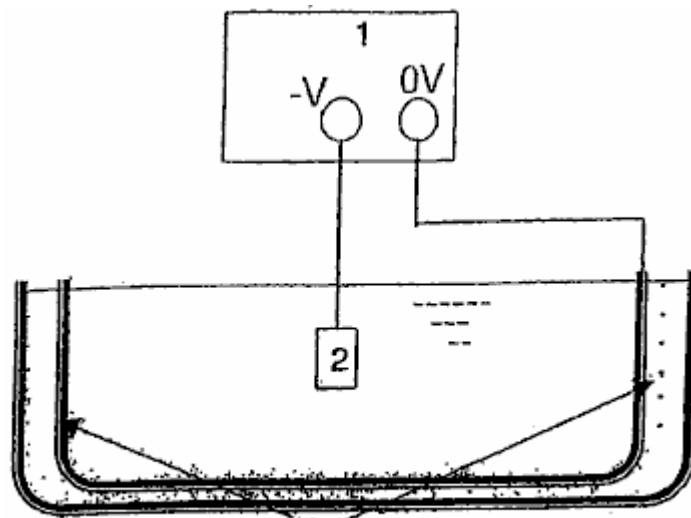

FIG. 6

Fig.6 illustrates an ultrasonic generator surrounding a bath similar to that in **Fig.5**. The generator generates ultrasonic waves which are transmitted into the electrolyte liquid and act to generate bubbles in the electrolyte which then surround the cathode. The cathode, which typically provides the surface for deposition, can be formed of a conductive material, a semi-conductive material or a non-conductive material, coated with a conductive coating. Cathodic materials that have been successfully used in this method are nickel, mild steel, stainless steel, tungsten and aluminium. The cathode can be in the form of either a plate, a mesh, a rod or wire. There may be any number of cathodes and the cathodes can be any shape or size. Any conductive material can be used for the anodes. Graphite, aluminium and stainless steel have all been successfully used to practise this method by the applicant. Generally, aluminium is preferred for the anodes. There may be any number of anodes and the anodes can be any shape.

In use, the bath is filled with an appropriate electrolyte. Broadly speaking, the electrolyte contains a solvent or carrier which provides a liquid environment, within which, electrolysis can occur and which also provides a support for plasma generation in the sense that it provides containment for the plasma generation. The electrolyte also contains a source of the material to be deposited in the form of a precursor. The electrolyte may also include additives for example for enhancing the electrical conductivity of the electrolyte and for assisting in bubble formation and a buffer to maintain a suitable pH in the cell.

In use, the article to be coated is placed in the bath where it typically forms the cathode. In some instances however, it may also form the anode. A voltage or potential difference is then applied across the electrodes and this voltage is set at a level that is higher than the firing point at which the system or cell achieves a stable glow discharge in which glow clusters envelope the cathode surface.

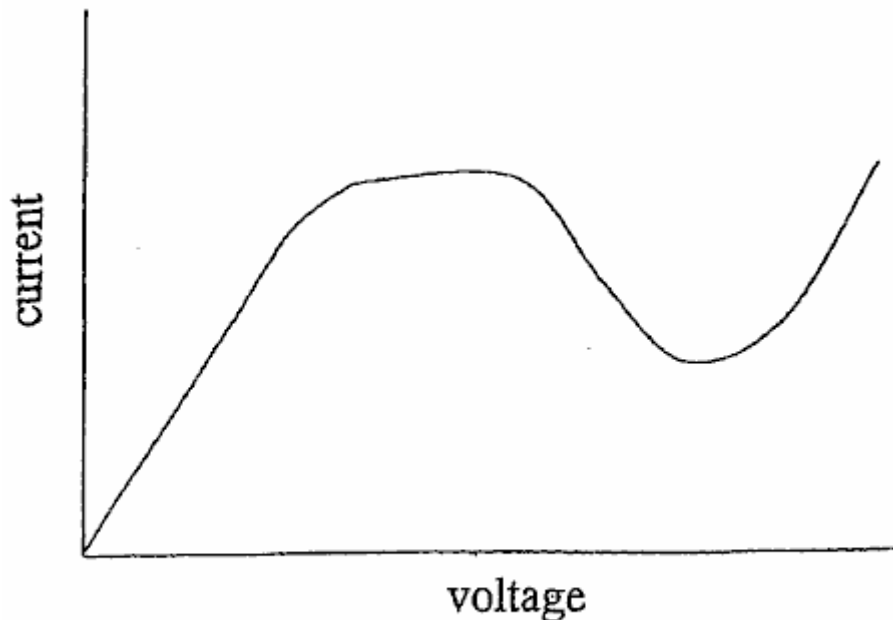
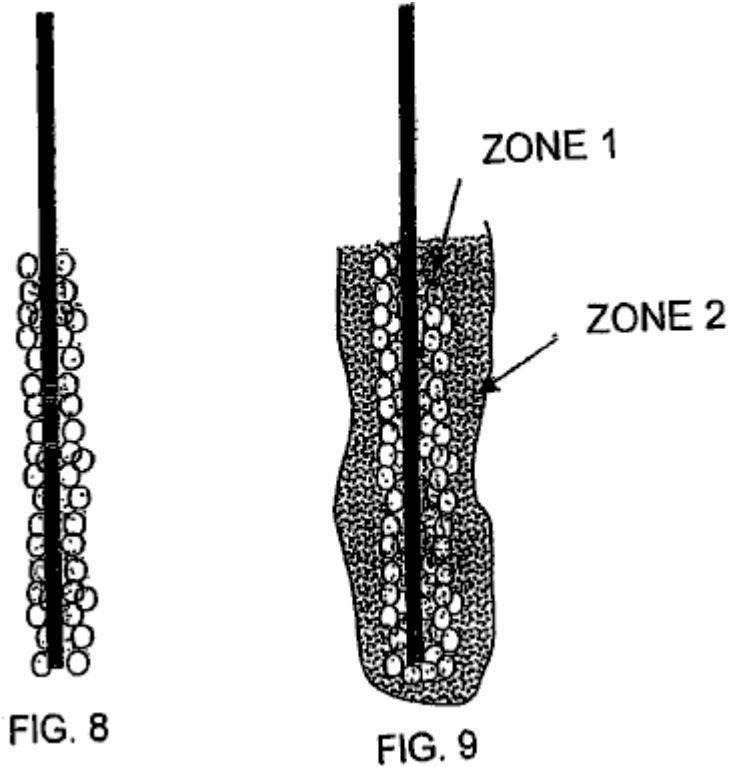

FIG. 7

Fig.7 illustrates a typical current against voltage profile for such a cell as the voltage is progressively increased. Initially there is an ohmic zone where the current increases proportionally with the voltage. After that the curve enters an oscillation zone where the current starts to oscillate. Applicant believes that this condition may be due to the fact that bubbles are evolving out of the solution and partly obscuring the electrodes. The bubbles form plasma, grow and then burst forming a shield shrouding the electrode. These bubbles block the conducting part of the cathode and this might lead to a decrease in apparent current density.

At the cathode, the evolved bubbles include hydrogen generated by the electrolysis of water in the electrolyte and by evaporation of liquid within the electrolyte. The bubbles may also be generated by other means as described above, for example ultrasonic generation. After some time, the number and density of bubbles increases until the entire cathode surface is sheathed in bubbles. At a critical voltage that is constant for a given system, known as the fire point, a glow discharge is formed. Experimental observation shows that this occurs when there is a near continuous bubble sheath around the cathode.

With a wire cathode, a tiny fireball or cluster of fireballs usually appears at the tip of the wire at the fire point. With further increases in voltage a glow discharge is established across the entire cathode. The glow discharge is dynamic and usually shows evidence of glow clusters and/or flashing through the bubble region. The glow discharge is caused by a dielectric breakdown in the bubbles. This is caused mainly by a high electrical field strength. Due to the presence of the bubbles the majority of the voltage drop from the anode to the cathode occurs in the near cathode region occupied by the bubbles. The electric field strength in this region may be of the order of 10,000 to 100,000 V/m. The voltage is set at a setting of 50 to 100 volts higher than the ignition point. This may typically mean a setting of 250 to 1500 volts. A preferred voltage setting would be at the low point of the graph in **Fig.4** within the glow discharge region.



The glow discharge causes the generation of a plasma in the bubble. **Fig.8** shows the formation of a bubble sheath around the cathode. **Fig.9** shows the cathode during stable glow discharge. As shown in the drawings, applicant has observed the formation of two distinct zones during stable glow discharge. In zone 1 where the glow discharge clusters are present, there is a plasma envelope that directly shrouds the cathode surface. This envelope is where plasma deposition takes place. The plasma interacts with the cathode surface in a process similar to ion plating and deposition occurs. A film is progressively formed through nucleation and growth on the cathode surface. Zone 2 is a plasma-chemical reaction zone, which forms the interface between the electrolyte and zone 1. This zone envelops the plasma deposition zone and is often clearly visible as a separate region with a milky appearance.

Dissociation, and possibly also ionisation of the electrolyte components, including the precursor, occur in the outer zone, zone 2. This gives rise to the species that are deposited on the cathode. The species is transferred from the outer zone 2 to the inner zone 1 by the electric field strength, diffusion, and convection. Deposition on the cathode then occurs for as long as these conditions are maintained and the precursor material is available in the electrolyte. After the glow discharge commences the temperature of the electrodes increases in a short space of time. The temperature of the electrolyte must be maintained within acceptable limits for certain type of application. To do this, electrolyte is drawn off from the bath and pumped through a cooling system as shown in **Fig.5**. The cooled electrolyte is then re-introduced into the bath. This cooling is required for both stability and safety reasons. Some of the electrolyte components are flammable. In addition electrolyte is consumed during the deposition reaction. Accordingly, it is necessary to top up the bath with additional electrolyte from time to time. A replenishment tank containing electrolytes is provided to perform this purpose.

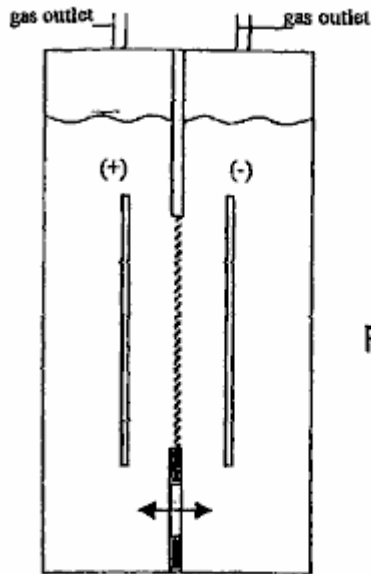

FIG. 10

**BASIC TWO ELECTRODE REACTOR
WITH GAS SEPARATOR DIAPHRAGM**

As shown in **Fig.10**, the reactor may include a pair of metal electrodes spaced apart and separated by an ion-conducting diaphragm. The electrodes can also be positioned horizontally or vertically.

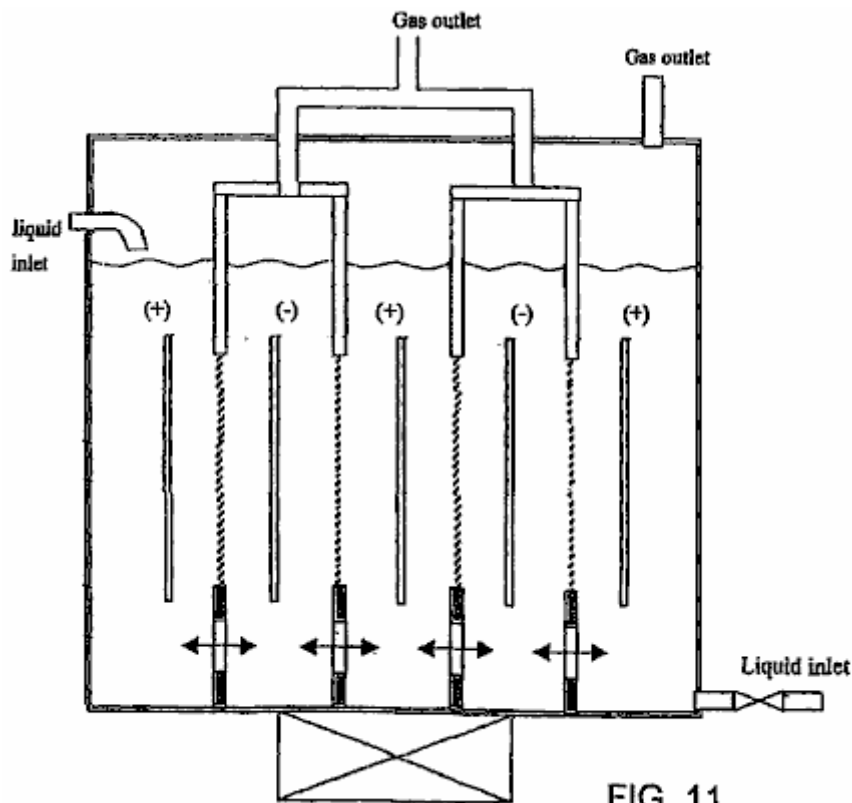

FIG. 11

Multiple Cell Reactors with common bath

As shown in **Fig.11**, the reactor may also include multiple pairs of alternating anodes and cathodes with a diaphragm. The diaphragm can be removed for decontamination and partial oxidation reformation process (**Fig.12**). In the case of reduction process, the hydrogen atoms produced on the side of cathode electrode are kept well separated from mixing back with oxygen by a diaphragm (**Fig.13**). It is possible to increase the throughput capacity of the reactor in treating contaminants with transverse flow through multitudes of alternating electrodes of anode and cathode (**Fig.14**). Wires or rods in tube reactors are suitable to adopt for hydrogen production and reduction process with the metal oxide confined within the narrow space within the cathode half cell and subjecting it to ultrasonic irradiation (**Fig.15** and **Fig.16**).

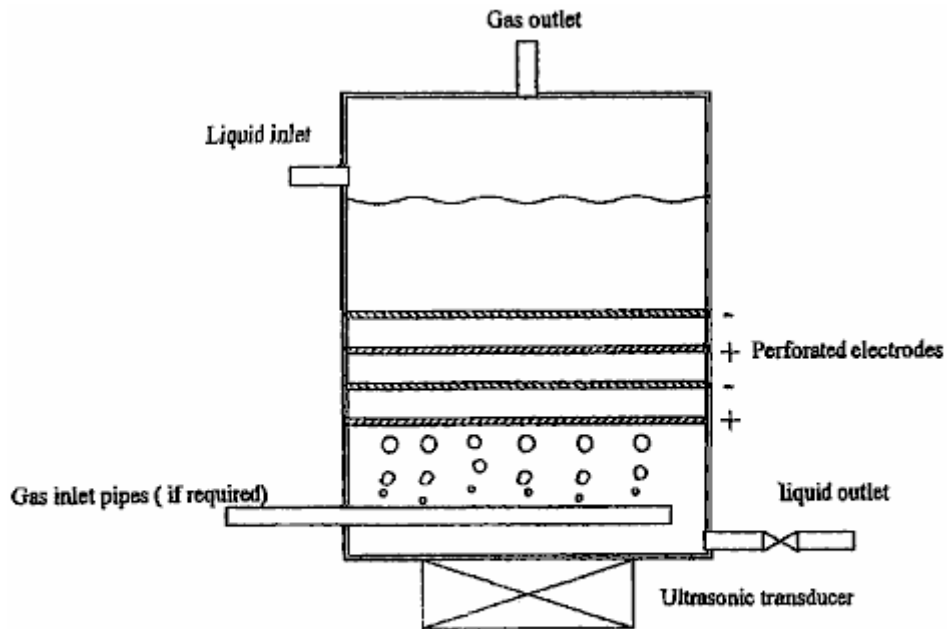

FIG. 12

Tower Reactor with Perforated Electrodes

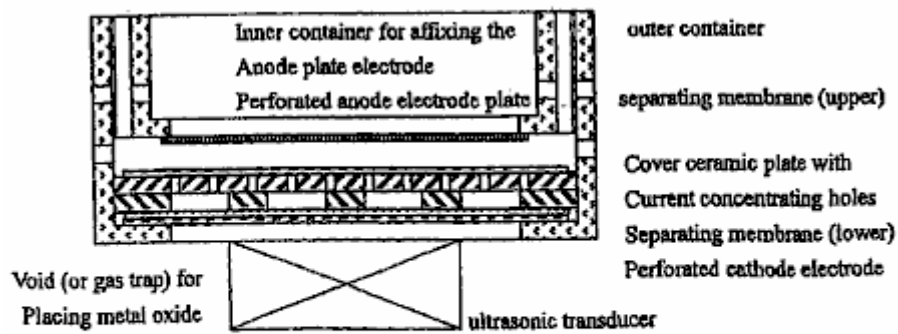
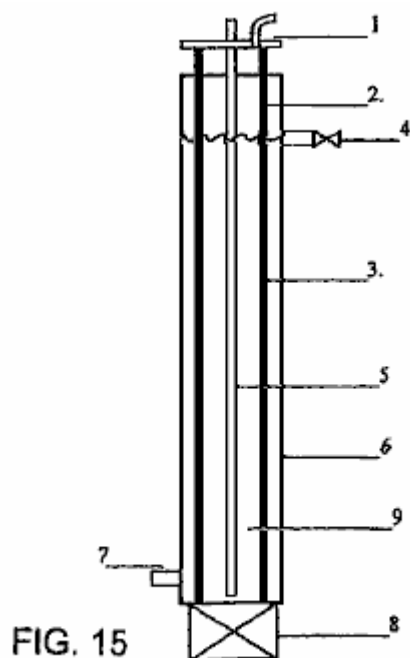
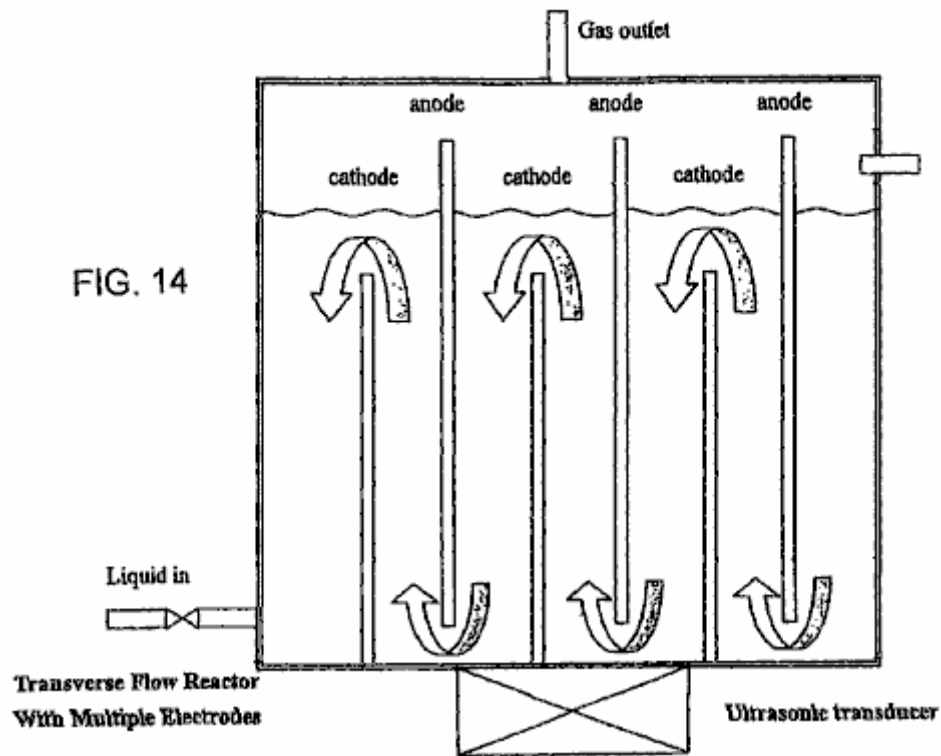

FIG. 13

Reactor for Metal Oxide Reducing Process
(which is to be placed inside an electrolytic bath)



WIRES OR RODS IN TUBE REACTOR
THE OUTER ELECTRODE SERVING AS BATH

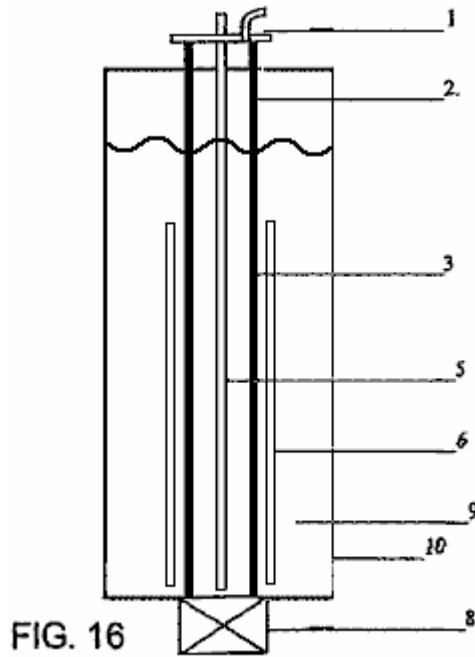

FIG. 16
WIRES OR RODE IN TUBE REACTOR

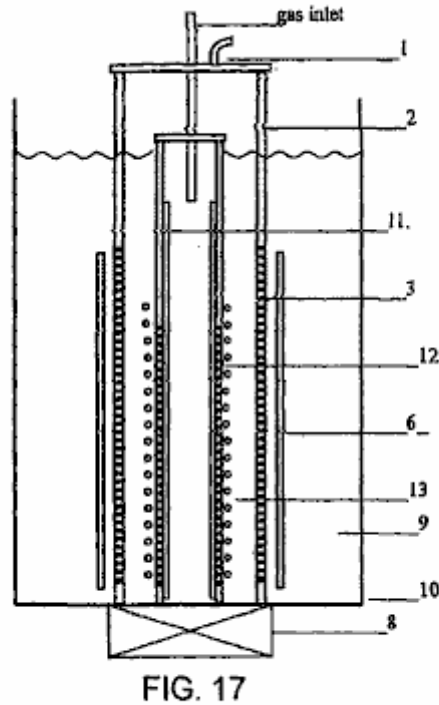
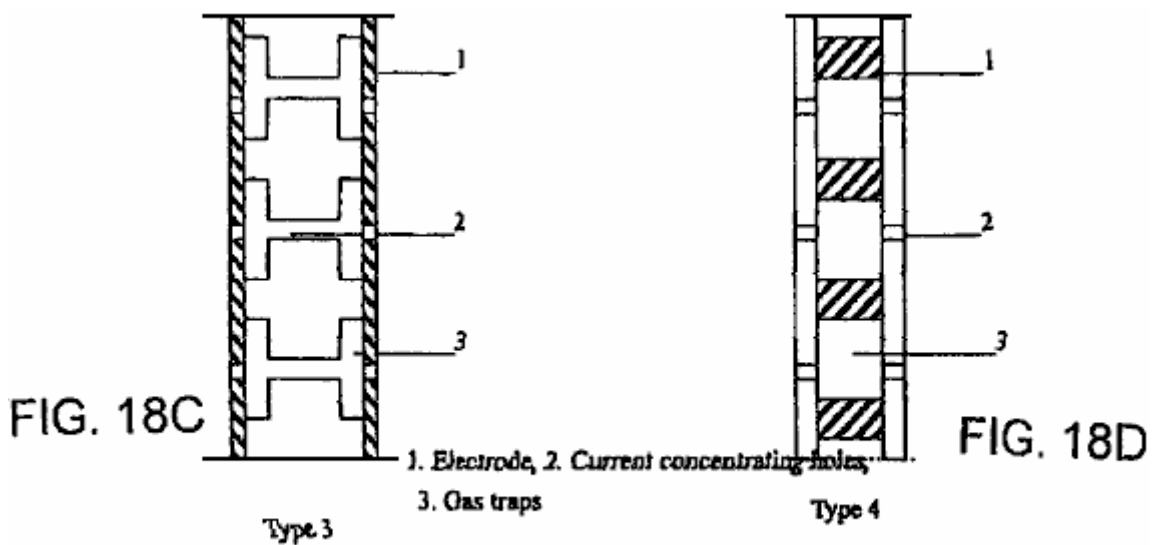
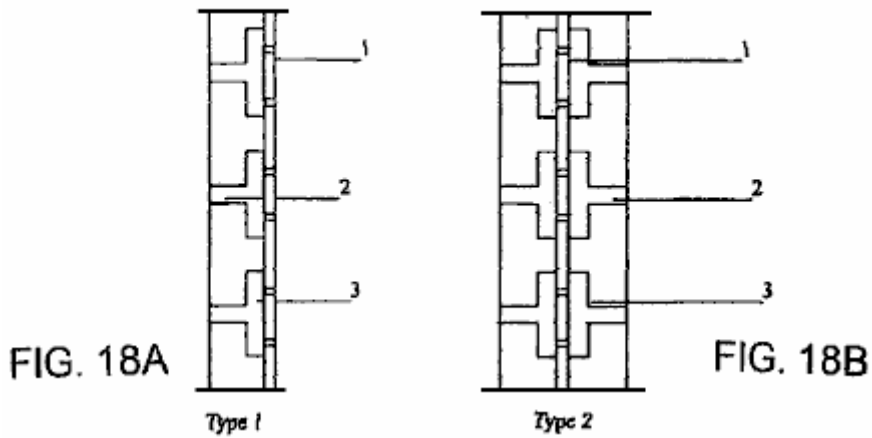

FIG. 17
TUBE IN TUBE REACTOR WITH PERFORATED INNER
TUBE COVERED WITH GAS-TRAPPING COVER LAYER

Tube in tube reactor (**Fig.17**) has a tube electrode within the outer tube electrode instead of wire or rod. The inner tube is covered with non-conductive materials of suitable thickness with small diameter holes and gas trap forming in between the inner metal tube which also have small holes formed correspondingly. The gap between the outer electrode and inner electrode is kept close but giving a minimum 3 mm to 5 mm space between the separation diaphragm and the dielectric cover of the inner electrode, to allow free flow of electrolyte and gas. Bubbles of gas will be discharged into the plasma discharging zone with hydrocarbon rich gas i.e. methane, natural gas, H_2S to undergo reformation for the production of hydrogen gas. It can also be adopted for decontamination of polluted gas laden with NO_x , SO_x and particulates; and reduction process where the metal oxide will flow through the space between the electrodes with the ultrasonic irradiation keeping the fine powder in colloidal and at the same time hydrogen gas or methane gas may also bubble in to provide the extra H_2 , H^+ and CO to enhance the reduction process.

Configuration of Electrode with Gas Trapping and Current Concentrating Cover Arrangements



Cross Section of Electrodes showing the Gas Trap and Current Concentrating holes

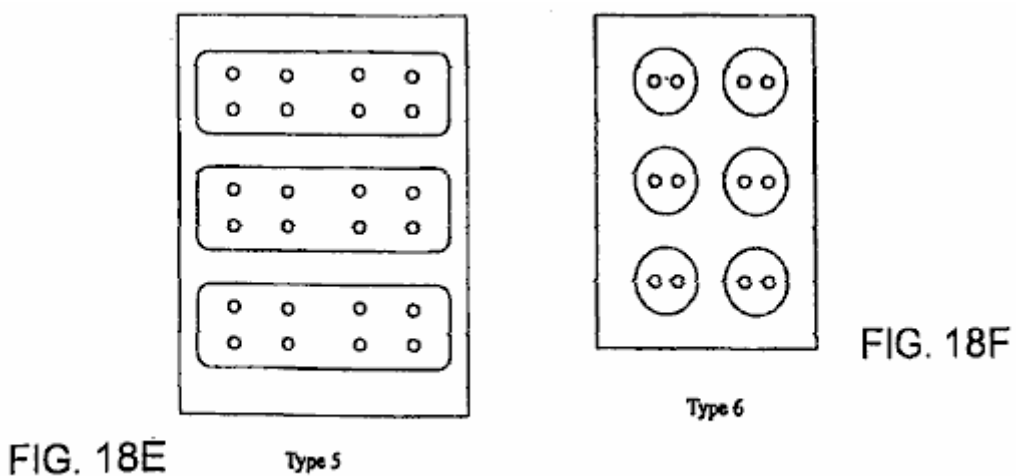

Plan or Elevation of Gas Trap Cover Plate (with perforated current concentrating holes)

A number of gas trap and bubble retaining arrangements are shown in Fig.18A to Fig.18F.

The under-liquid plasma discharge, in order to produce various reductive, oxidative, radicals and neutrals species through excitation, ionisation and dissociation of the liquid molecules and atoms, requires high voltage input DC or AC, normally within 3 KV and current density under 3 Amp/cm². The electrodes cathode and anode have to be kept as close as possible but not close enough to cause arcing. The electrode surface is preferably flat, even and smooth with no pronounced irregularities. Because of the need of placing diaphragm and complementary gas trapping and retaining construction on the discharging electrode, a minimum distance of 6 mm to 15 mm has been experimented with and shown to produce steady glow plasma under-liquid. With better material choice and engineering capability, there is no reason why the electrode space distant cannot be further reduced. The size, shape and arrangement of the electrodes is not restricted, but the electrodes will usually be somewhat smaller than those required for conventional electrolysis, for the same gas production volume. Both the electrodes, anode and cathode, can be at work at the same time as the plasma discharging electrodes especially if a gas-trapping dielectric cover construction is provided.

Experiments have been conducted to establish the basic criteria to generate steady and rapid cyclical non-thermal plasma glow discharge under-liquid with basic DC high voltage and low current input at atmospheric pressure and ambient temperature leading to the proposal of a phenomenal model of reactor structure and electrode configuration which demonstrate the usefulness of bubbles or gas pocket that creates the under-liquid environment for plasma discharge and it also provides the back ground of further improvement and construction of reactor unite which verify the inventive idea of under-liquid plasma and it subsequent practical applications.

A reactor according to the present invention can basically follow that of a simple water electrolysis cell with one anode electrode separated from the cathode electrode with an ion conducting membrane and yet has the capability to prevent re-mixing of the produced gas on each half-cell. The electrolyte allows moving across the membrane or replenish through the opening in the reactor. In order to increase the proficiency of the reactor the cathode electrode is placed inbetween two anode electrodes and separated from them by a membrane. The hydrogen gas produced is isolated and collected independently. The polarity of the electrode can be reversed with the anode electrode in the middle when oxidative species are needed for the decontamination process. Most importantly, the simple electrode and reactor unit will form the basic module, placed inside a common bath and linked together to form a lage production unit, and these modules can be replaced individually.

Despite the apparent success of the simple perforated plate-to-plate electrode arrangement, it does not preclude other electrode configurations and arrangements such as tube in tube, wire in tube and other flat surface electrodes having different surface structure e.g. wire mesh, expanded metals, pinned plate, sponge porous metal, corrugated plate etc. as long as it is a good electric conductor, corrosion resistant, heat-tolerant material, i.e. stainless steel, aluminium, graphite, platinum etc. The shape and size of the electrode piece is not restricted and sometime it may form the object article which is to undergo plasma surface enhancement treatment.

In practice, a reactor with vertical electrodes, suits plasma-assisted water electrolysis, reformation of hydrocarbon liquid fuel, production of nano materials and decontamination process, while the reactor with horizontal electrodes suits reformation of hydrocarbon gas such as natural gas, methane, hydrogen sulphurs and the like.

This ability to generate steady plasma discharge, can well be adopted for other useful purposes such as thin and thick-film deposition and additional method in the creating of cold fusion.

There have been a series of experiments conducted to generate non-thermal plasma under-liquid by utilising the gas bubbles self generated during electrolysis, electrochemical reaction, heating and releasing of dissolved air or gases in the liquid. Bubbles can also be produce with the influence such as transient bubbles created by shock waves resulted from pulsed power input, ultrasonic cavitations, laser heating and hydraulic impingement. External introduced gas (e.g. air & fuel gas) is found to work well in providing bubbles environment for ready plasma discharge in a steady manner. A number of experiments have also been conducted to test the applicability of under-liquid plasma in the field of hydrogen generation, hydrocarbon fuel reformation, sterilisation and decontamination and reduction of metal oxide. Because of the restriction of the power converter that some result is less than ideal but it all indicate the potential of the under-liquid plasma which is in the first place having the same physical/chemical capability as its counter part operating in gases environment in exciting, ionisation and dissociation, but with some distinctive advantage which has well been described in the foregoing text.

Generation of steady plasma discharge under-liquid has been one of the primary objectives in the research. In general the generation of steady plasma glow discharge are influenced by a number of factors, such as physical and chemical properties of the liquid, its conductivity, temperature, electrode type, electrode spacing, gas retaining or trapping arrangement, current density, voltage input, reactor construction, liquid circulation, influence of ultrasonic irradiation, pulsed power input etc.

There are of course a number of electrode shapes, size and configuration one could choose. In order to find out the how important is the supply of bubbles or gas pocket affects the generation of plasma, a gas retaining or

trapping covering with current concentrating conducting holes over perforated plate electrode is formulated, which has proved effective producing steady glow plasma discharge within the range of 350 V to 2 KV (2,000 V) and current up to 850 mA, but most the time around 100 to 300 mA range. This is considered low in compare with other under-liquid plasma system (i.e. Plasma arc, pulsed high voltage and current electric discharge). Throughout the experiments, a horizontal reactor was used. However an alternative reactor is a vertical reactor.

INTRODUCTION TO THE EXPERIMENTS

Several groups of experiments have been conducted:

1. Preliminary trial experiments
2. Plasma assisted water electrolysis
3. Reformation of methanol
4. Reformation of emulsified diesel
5. Reformation of LPG as hydrocarbon gas (methane is not available in the market)
6. Decontamination or sterilisation of food drink
7. Reduction experiment of TiO₂.

In the preliminary trial experiments a number of electrode types have been adopted and have eventually select the wire to plate configuration and perforated plate to perforated plate or wire mesh as the most suitable under the limiting power supply condition where max. voltage available is 2,000 V and the maximum current is 1,200 mA. In reality, the current input is voluntarily restricted to work below 900 mA for durations not exceeding 30 minutes, to avoid damage to the converter which has happen in a number of occasion which caused stoppage of the experiments for weeks.

To overcome the power supply limitation, and to achieve steady plasma glow discharge, a gas-retaining or trapping cover or layer with current concentration holes has been devised to cover the discharging electrode surface (perforated electrode plate) which is the basic features adopted in the construction of reactor.

In the trial experiments, it has been demonstrated that infrequent visual plasma discharge begins with a voltage of 350 V and steady plasma can be achieved in around 550 V. The initial current input reaches 850 mA and begins to fluctuating in the range of 150 to 650 mA. On many occasions the current fluctuated at 100 mA to 350 mA.

Through these experiments, the mechanism of generating bubbles or gas pocket dielectric barrier which impedes the current flow, leading to an increase of voltage until a threshold voltage is reached which causes the electric breakdown and the formation of plasma inside the bubble, at which point the current immediately returns to its normal level and then another cycle of discharge is established. When the discharge is infrequent it resembles a corona streamer discharge but as the voltage increases, the glow discharge becomes a continuous glow over an extend electrode surface resembling a glow plasma discharge. The colour of the discharge appears as an orange-yellow or red colour in the electrolysis of water and the temperature of the discharging electrode ranges from 50°C to about 90°C and the temperature of the bath liquid ranges from 40°C to 70°C. No sign of any damage to the electrode or its covering plastic gas trapping plate was observed even after prolong experimentation. When the voltage is allowed to increase beyond the glow plasma region, a plasma arc begin to occurs and becomes an intensive bright blue discharge when voltage is further increased and this causes damage to the metal electrode and plastic covering plate which is easily seen.

On two occasions, hydrogen production was recorded which produced a gas volume with an equivalent energy conversion efficiency up to 56%. Due to damage to the reactor by the plasma arc, that particular experiment cannot be repeated as new model of reactor is designed to achieve low current input and early high voltage response. However with the apparent success of the trial experiment, it shows that a more suitable reactor can be designed specifically for the purpose of hydrogen production by plasma assisted water electrolysis and a higher energy efficiency figure can be achieved with a small reactor.

PLASMA ASSISTED WATER ELECTROLYSIS

Experiments to check the behaviour of plasma discharge at different voltage input levels were carried out. Despite the apparently large volume of bubbles boiling inside the reactor, the total volume of gas produced was unexpectedly low. This may have been caused by the horizontal reactor design adopted throughout the experiments. This may have allowed the hydrogen gas recombine with the hydroxyl ions and convert back into water again. A vertical reactor would be more suited for the plasma assisted water electrolysis where the produced hydrogen gas will rise quickly to the top of the reactor and can be channeled away from the area filled with OH ions.

In this experiments plasma discharge begin to occur at 1,350 V with current fluctuating around 100 mA to 200 mA. At about 1,550 V the reactor produced highest volume of gas. Plasma arc discharge occurs at 1,900 V and is

becoming vigorous when the voltage is increased further. KOH of 0.02% concentration has been used as electrolyte additive throughout the experiment.

The production of gas appears to have a linear relation with time but varies substantially with different voltage input. The rate of energy consumption is increasing slowly with time in a constant rate which varies with the voltage input and its corresponding energy consumption per unit gas volume produced is having a peak at the first 10 minutes of the experiments and level off with time. The temperature in the electrode rises sharply from 50°C to 90°C and is maintained more or less at that level throughout the test. The temperature in the bath liquid within the reactor rises slowly from its ambient temperature to around 50°C to 55°C.

EXPERIMENTS WITH METHANOL

Several sets of tests have been conducted with the aim of finding out how different hydrocarbon fuels will be affected by the non-thermal plasma under-liquid system. A methanol / water mixture with methanol concentrations of 5%, 10%, 15%, 20%, 25%, 30% and 40% were tested using the same method and equipment set-up already used for the plasma-assisted water electrolysis. There are three independent tests for each methanol concentration. It has been observed that the gas production is peaked at 25% methanol concentration and the energy consumption per unit gas volume produced is also lower than the others and is nearly at constant rate around 0.0225 Kw.h/L. The voltage input for each test is kept at 1,850 V and the current fluctuating in the range of 100 mA to 200 mA. The temperature measured at the cathode electrode started at 80°C and rose quickly to reach over 200°C at the end of a 30 minute experiment. The temperature recorded in other tests stayed within the range of 60°C to 80°C. The temperature of bath liquid at 25% concentration stayed in the range of 50°C to 60°C, which is typical for each of these tests.

The greatest surprise coming out of the experiments is that the produced gas is composed of two gases. One is hydrogen gas and the other is oxygen gas and no trace of carbon dioxide is found. Repeated examination of the gases produced shows the same result and the hydrogen is having an average value of 51.3% and oxygen 48.7%. This is later found out that the presence of oxygen in the gas is the result of the removal of the separating diaphragm. An acidic electrolyte is preferable in order to increase the hydrogen gas percentage in the output gas mix. This is shown in the latest experiments using sulphuric acid of 0.02% concentration.

A set of experiments with the use of 40 KHz ultrasonic bath having methanol concentration of 10%, 15%, 20% and 25% with the same reactor and equipment arrangement have been conducted to find out the influence of ultrasonic radiation. It has been observed that gas production at 25% is substantially higher than the others and yet the energy consumption per unit gas volume produced is around 0.015 Kw.h/L throughout the 30 minute experiment, which is lower than that without ultrasonic radiation.

The chromatographic analysis of the output gas having an average value of 97.56% hydrogen and 2.4039% of carbon monoxide. Chromatographic analysis of gas produced by reformation of methanol with ultrasonic radiation. Methanol concentration at 25%, and conductive reagent 0.02% sulphuric acid.

TABLE 1

Test	Resident time minutes	Composition V/V %	Gas type
First Test	0.364	98.9937	H ₂
	1.047	1.0063	CO
Second Test	0.364	96.7418	H ₂
	1.047	3.2582	CO
Third Test	0.354	96.9719	H ₂
	1.048	3.0281	CO
Average		97.5691	H ₂
		2.4309	CO

EXPERIMENTS WITH LPG

Decomposition of LPG by under-liquid plasma has been conducted (methane or natural gas is preferred but none is available in the market). The LPG is allowed to pass through the horizontal reactor through the perforated anode plate and enter the reactor and trapped at the cathode plate where plasma is taking place at voltage 1980V and current at 100 to 130 mA input. C₃H₈ and C₄H₁₀ are the two main components of LPG, it is expected that the volume output having been subjected to plasma dissociation should be larger than the original input volume. This is found to be so that the output gas volume increases by about 50%. The experiment is conducted together with ultrasonic radiation. It is regrettable that the chromatogram is incapable of undertaking analysis of the output gas composition. The next set of experiments should be conducted with methane or natural gas so that more definitive result could be obtained. Rudimentary analysis of the produced gas has shown the presence of H₂, CO₂ and C₃H₆ etc.

REFORMATION OF EMULSIFIED DIESEL AND WATER WITH ULTRASONIC IRRADIATION

Decomposition of emulsified diesel with distilled water has also been carried out. Diesel oil in 25% and 50% by volume has been emulsified by adding 1.25% emulsified agent inside the ultrasonic bath. Since the diesel oil is dielectric, a KOH additive is needed. The emulsified liquid is subjected to plasma discharge at a voltage of 1,850 V and a current fluctuating from 100 mA to 200 mA for a period of 30 minutes. The temperature of the cathode electrode increased from 70°C to about 94°C during the experiment. The gas volume produced was 160 ml with 25% diesel and 1,740 ml with 50% diesel, which is substantially higher and its energy consumption is 0.1213 KWh/L. It is clearly indicated, that gas production is proportional to the diesel content in the emulsion. Because of the limited power supply capability, the voltage of 1,850 V is merely adequate to produce some plasma discharge but it is far from establishing extensive vigorous plasma with higher current and voltage input, which would produce more gas.

STERILISATION (DECONTAMINATION) OF MULBERRY FRUIT DRINK

The ability of non-thermal plasma to decontaminate noxious chemicals and gases has already established. This experiment is conducted to find out how well the under-liquid plasma may apply in the field of beverage sterilisation with low levels of plasma radiation and keeping the treated liquid within an acceptable temperature.

Two liters of 15% concentrated fruit drink is placed in the bath where a horizontal reactor is submerged. The bacteria count and mold colony count is obtained before the forty minute test. A sample of the fruit drink is extracted at 20 minutes and 40 minutes. The mulberry drink has good natural conductivity so no additive is required. The applied voltage is kept at 1,200 V and the current fluctuates around 200 mA. The temperature at the electrode is maintained at around 62°C and the bath liquid (fruit drink) is kept at around 50°C.

TABLE 2 - The micro-organism count

Time (minutes)	Bacteria count/ml	Mold colony count/ml
0	3,400	37,000
20	1,300	17,000
40	90	10

The favour and colour of the fruit drink had not changed after the test. The bacteria sterilisation is 97.5% and that of mold colony has been sterilised more than 99%. This has given proof that the under-liquid plasma has the same capability as those operated in a gaseous environment.

The time for the treatment could be reduced by providing forced circulation of the liquid and increasing the electrode size. Sterilisation of drinking water imposes no limit on the temperature. Higher voltage input for better plasma glow discharge spreading over larger and multiple electrodes should be able to remove all harmful chemical substance, bacteria, biological matter and microbial matter, thus meeting the municipal requirement for drinking water.

REDUCTION OF METAL OXIDE

One trial experiment to reduce TiO_2 back to Titanium metal has been attempted with little success. It was found that in the X-ray diffraction test, minor traces of titanium nitride and titanium monoxide (TiO) were found. In the experiment, only a minor electrolyte of 0.05% KOH with 25% methanol added to the distilled water was used to increase the production of hydrogen. The applied voltage was fixed at 1,850 V and the current fluctuated in the range of 200 mA to 500 mA. Ultrasonic radiation up to 40 KHz was also provided through an ultrasonic bath. The temperature recorded in the bath liquid rose from 46°C to 75°C at the end of the 60 minute test. The fine TiO_2 with was suspended with ultrasonic radiation, in the bath liquid in colloidal form, showing as a milky white colour, which gradually became a milky yellow colour towards the end of the experiment. The bath liquid also became viscous.

The X-ray refractive "d" value of TiO_2 were:

Before the experiment: 3.512, 1.892, 2.376 but after the experiment there were two new groups of "d" measurements not seen before the experiment:

a: 2.089, 1.480, 2.400

b: 2.400, 2.329, 2.213

This indicates a new material, positioned between TiO and $n\text{-Ti}_3\text{N}_2\text{-x}$.

This experiment indicates that a change did happen to the TiO_2 , possibly because of the limited voltage and current available as input, which could not provide the intensity of plasma discharge needed to effect the reduction process properly. Higher concentration of either HCl or H_2SO_4 should be use as reagent demonstrated in the following chemical reaction and in the same time serving as electrolyte. The horizontal reactor is not a suitable piece of equipment to undertake such experiment; it is adopted merely for convenience. A wire-in-tube and tube-in-tube reactor would be a suitable candidate, which would keep the metal oxide exposed to plasma discharge throughout the whole of the duration of the experiment. Further, more hydrogen or CO gases produced during the process may be passed back to the reactor to enhance the reaction. (Methane is a suitable gas for this type of reduction process, as both hydrogen and CO gas will be produced to enhance the reaction). The following are the chemical formula, which suggested by transforming TiO_2 to either TiCl_4 or TiOSO_4 as a soluble ionic compound, will facilitate its reduction with prolong exposure to active atomic hydrogen under the influence of a plasma catalytic environment.

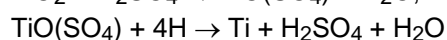
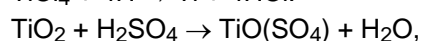
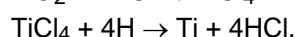
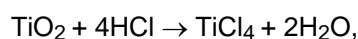

Where TiCl_4 is readily produced by an established process from ilmenite.

Similarly, aluminium oxide Al_2O_3 can first be transformed to AlCl_3 , which is soluble ionic compound, ready to be extracted by electro-deposition enhanced with plasma-reduction and plasma-electroplating process:

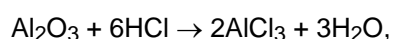

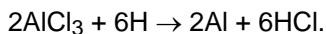

In the case of electrode positive oxide such as Fe_2O_3 , it can be reduced in the presence of ionised atomic hydrogen and the presence of carbon monoxide with catalytic reactive plasma irradiation.

Fine metal oxide powder irradiated with ultrasonic waves will maintain in colloidal form allowing it to be exposed to the reduction agent atomic hydrogen and/or carbon monoxide. The process of ultrasonic cavitations and collapse is also known to create extreme localised high temperature up to $10,000^\circ\text{K}$ and thousands of atmospheres of pressure together with the high temperature at the impact point of the fine powder particles which is beneficial to the entire reduction process.

DETAILS OF THE EXPERIMENTS CARRIED OUT

Establishing Generation of Under-Liquid Plasma:

Distilled water is used in the experiments with 0.05% KOH as a conducting reagent. The voltage is controlled at 1,250 V & 1,850 V. The current is raised in steps of 100 mA until it reaches 850 mA. In the beginning the voltage remains low and gradually builds up as more gas bubbles are generated. Once it reaches a certain high level the current drops immediately. The self-regulating current and voltage input of the power unit automatically switches from current input control to voltage input control. At 45 seconds after switching the experiment on, the voltage rose to 470 V and the current dropped below 500 mA. From 3 min. 10 sec to 5 min 20 sec, the voltage rose to a relatively high level while the current kept on fluctuating. After a period of unstable voltage and current movement they become stabilised at 20 min with the characteristic high voltage and low current. At this instant prominent glow is observed at the perforated cover plate (current concentrating holes). The temperature of the cathode electrode has risen and stays steady at around 70°C .

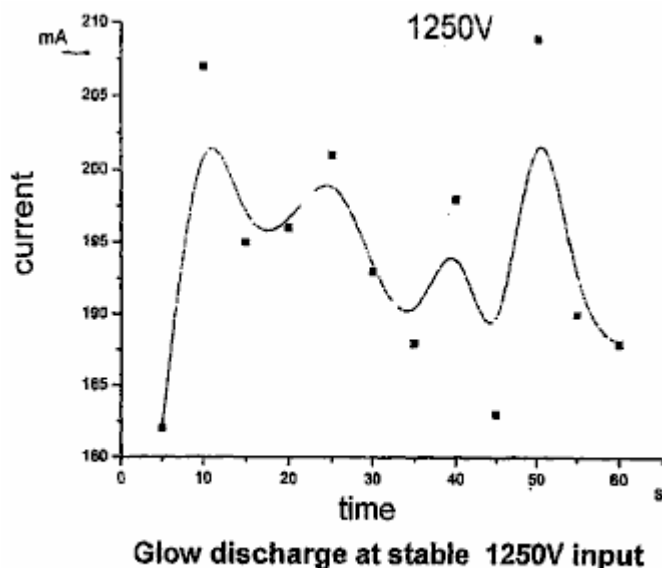

FIG. 25

Fig.25 shows the current fluctuating with stable 1,250 V voltage input and a steady plasma glow discharge. The temperature of the cathode increases rapidly in the early stages and then becomes steady at the 5 min mark, and then rising slowly to it's highest temperature of about 96°C .

OBSERVATION

Generating Under-Liquid Plasma:

In accordance with the experimental results, it is possible to generate non-thermal plasma under-liquid providing that certain conditions are met: a suitable power supply, electrolytic liquid, reactor and other supplementary equipment.

The design of the reactor, with relatively low voltage and limited power rating (restricted current input) requires special construction to trap or retain gas and at the same time to raise the current density at the discharge area.

The gas trap or chamber should be of a suitable size. If the gas trap or chamber is too big, then the trapped gas is too thick which requires a much higher voltage for discharge breakdown and prolongs the time of each cycle of discharge. It becomes difficult to maintain rapid cyclical steady glow discharge. The perforated covering plate, is also an important part of the electrode structure, concentrating the current density. The thickness of the perforated plate and the size of the gas trapping chamber should be carefully controlled so that the electrode spacing gap is not unduly wide as that also influences the voltage requirement. The size and disposition of perforated holes can be determined by trial and error. Wide electrode spacing increase the voltage input requirement and unsuitably close electrode spacing will cause early occurrence of plasma arcing with high current surge and generation of temperatures which will damage the electrodes and their attachments.

The power unit should be of adequate power rating. The electric breakdown is highly dependent on the high voltage supply. If the rating of the power supply unit is inadequate, it could easily be damaged during sudden the high current surge caused at cyclical electric breakdown. There will be no plasma discharge if the power input is inadequate.

The electrolytic liquid should have suitable conductivity, not too low nor too high. Voltage cannot be easily raised between two electrodes the liquid has high conductivity and no plasma discharge will be generated unless there is a high voltage input. The discharging electrode may be fully encapsulated inside a bubble barrier, but high conductivity liquid allows the current to pass through the bubble-liquid interface which in turn, also prevents the voltage rising high enough. If the conductivity of the liquid is too low, then the bubble barrier forms a complete dielectric barrier which requires a much higher inception voltage to cause electric breakdown or discharge and at the same time, the passage of current becomes too low which results in a low current density which also influences the occurrence of discharge. A much higher breakdown voltage (discharging voltage) creates electric arcing in gaseous condition which is no longer considered non-thermal under-liquid plasma discharge.

CONCLUSIONS

1. Gas layer or bubbles form the dielectric barrier that provide the environment for building up the discharge voltage and gaseous space for plasma discharge to take place. High voltage and relatively low current input is characteristic of under-liquid plasma.

2. With the characteristic high voltage and low current requirement, the under-liquid plasma can be generated over a wide range of liquids. The electrolyte liquid can be acidic, alkaline or a solution of salts. Liquids containing conducting impurities or a mixture of organic compounds may also serve as electrolyte such as the case of tape water and fruit drinks.

3. There are a number of factors which would affect the generating of under-liquid plasma such as voltage, current density, configuration of electrodes, area of electrode surface, electrode gap spacing, electrolytic physical and chemical properties, gas retaining and trapping arrangement, provision of plasma enhancement, ultrasonic cavitations, pulsed power supply, ambient temperature and reactor construction. This appears complicated, but the experiments undertaken have demonstrated that all the mentioned factors can be manipulated to achieve generation of stable non-thermal plasma at one atmosphere of pressure.

4. Plasma is the fourth state of matter. It has been widely employed in the field of chemical, electronic, materials and energy industries. Plasma generated under-liquid plasma has its own intrinsic characteristics and advantages, which have already proved to be a useful tool for plasma electroplating or deposition of both metallic and non-metallic materials. It will find its application in the plasma-assisted water electrolysis for hydrogen production; reformation of hydrogen rich compounds or hydrocarbon fuel (gas and liquid); decontamination of both liquid and gas pollution discharges containing persistent harmful chemicals, dissolved heavy metals and organic and biological contaminants; sterilisation of fruit drinks, potable water supply; and reduction of material oxide such as oxide ores, metal oxide as an alternative method metal refinement. It is probable that the proposed under-liquid plasma generation, and this established basic scientific information, would form the basis for further refinements leading to the practical new applications put forward in this patent application.

PLASMA ASSISTED ELECTROLYTES FOR HYDROGEN PRODUCTION

Water electrolysis is still used for the production of pure hydrogen. This hydrogen production is restricted because of its relatively low energy conversion efficiency. In order to achieve higher energy efficiency, the electric voltage must be kept low to avoid energy loss through heat conversion. There are also claims that the energy efficiency can be improved by better electrode configuration, an increase in the reactive surface area, reduction of the electrode gap and increasing the operating pressure. The PEM solid electrode system is in its early development and its efficiency remains similar to that of water electrolysis system. In any case the basic principle of water electrolysis has not changed since it was first put to use. Electrolysis as a whole, is considered to be non-competitive with the competing production process of reforming hydrocarbon fuel, but electrolysis has the advantage of being a clean process producing high gas purity and CO₂ is not produced.

The hydrogen bubbles evolving from the electrode surface slow down with time when tiny bubbles gradually built up and smother the electrode surface. These are not easily dislodged and the rate of hydrogen production is reduced further as those tiny bubbles become a barrier to current flow between the two electrodes.

The proposed invention is closely related to the water electrolysis process but the mechanism of separating hydrogen from water molecules is different. Generating non-equilibrium plasma within the bubbles that smother the electrodes will break down the dielectric barrier bubble layer and cause the normal flow of current to be resumed. At the same time, water molecules contained in the bubbles coming into contact with the plasma discharge, will be dissociated to produce extra hydrogen. In addition, the vigorous plasma discharge near the electrode surface will also create a hydrodynamic condition, which will wash away the fine bubbles which block the current flow. The mechanism of producing hydrogen by plasma discharge is different from the conventional electrolysis which splits the ionic water molecules by electro-polarity attraction, while in the plasma discharge the water molecule is broken down as the result of electron collisions. The water molecules under the plasma discharge irradiation would lose one electron due to electron collision to yield $\text{H}_2\text{O} + e \rightarrow \text{OH} + \text{H}^+ + e$

The hydrogen produced is of high purity. Ordinary potable water or rainwater with a very low concentration of electrolyte can be used as the main source of material, instead of distilled water, as they contain sufficient impurity to be slightly electro-conductive.

The experiment has demonstrated that hydrogen gas can be produced with plasma glow discharge as a supplementary process to the conventional method. The energy required to produce 1 cubic meter of hydrogen with plasma glow discharge with a very rudimentary reactor has achieved an efficiency of 56% which can be further improved with better engineering, by closing the electrode gap distance, selecting the right concentration of electrolyte, reactor construction and better means of trapping and retaining gas near the discharge electrode.

High temperatures of up to 90°C is recorded in the electrolyte, which increases within very short time of the reaction. This may in part due exothermic reaction of recombining H and OH to water. The excessive heat can well be utilised as secondary source of energy. The gas or vapour bubbles by heating assuming greater importance as source materials for plasma dissociation leading to the production of Hydrogen. The high purity oxygen co-produce is also a valuable by-product with many applications.

Since high voltage with moderate current is needed in the plasma process, the production rate per unit area of electrode surface is high, and so only a small reactor is needed for the production of hydrogen, especially when other plasma enhancement methods are employed, such as ultrasonic cavitations, pulsed powers and RF input.

The electrodes could be of any conductive materials such as aluminium, stainless steel, graphite, tungsten, platinum, palladium etc. The size of the electrode for the plasma discharge is much smaller than that required by the conventional electrolysis to produce the same quantity of gas. As a result of this, a smaller reactor is possible.

Sponge porous electrodes will increase the reactive surface area available to produce electrolysis gases. In the experiment, several layers of fine wire mesh were packed tightly together to mimic a sponge porous electrode plate.

Some of the basic electrode configuration is: plate to plate; perforated plate to perforated plate; plate or perforated plate to wire mesh; wire mesh to wire mesh; plate to pinned plate; dielectric coating on one or both electrodes plate or mesh or pinned plate, tube in tube and wire in tube arrangement. It is noted that electrode configuration including any lining or covering materials that help to concentrate the current density and having the ability in retaining gas around the electrode would be adopted which will help to lower the voltage and current requirement to generate steady plasma discharge.

In order to create an environment for steady and short cyclical plasma glow discharge as already mention in the previous text, the electrode configuration should be so structured to retain the bubbles and concentrate the current density and yet keeping the true electrode gap distance to a minimum. This creates a suitable voided

space either in the metal electrode or in the covering materials, capable of retaining gas while at the same time having the mechanism to concentrate the current density to a localised discharge point. This leads to a wide variety of designs and choice of materials to satisfy plasma discharge requirement.

In order to avoid recombination of H^+ and H_2 with OH ions and reverting back to water, the hydrogen atoms after regaining their lost electrons through contacting the cathode should be allowed to escape quickly from the area which abounds with other oxidation species and radicals. This has greatly influenced the productivity of hydrogen gas. If H^+ and OH is allowed to recombined, despite of the apparent bubble boiling in the reactor very little gas can be collected and the temperature in the reactor rises quickly which could well be the exothermic effect of recombination of H^+ and OH.

The hydrogen produced is collected separately from the oxygen. Since the produced hydrogen gas contains a fair amount of water vapour, the hydrogen gas is collected by passing it through a water chiller or other known method, so that the measured gas volume is at room temperature with minimum water vapour content.

The basic plasma assisted electrolysis cell or reactor can be produced in modular form which can be mounted side by side and placed inside a single electrolytic tank with their respective power and output gas collected to form a major production unit. Several reactor types can be employed for the production of hydrogen. Rod or wire in tube reactor, tube in tube reactor, single or multiple cell reactors are also suitable for the plasma assisted water electrolysis. The gas retaining and current concentrating cover will be affixed on the cathode electrode facing the anode electrode. A horizontal reactor whose cathode has a gas-retaining cover can be placed on top of an anode which is separated by a diaphragm and the hydrogen gas will then collect in isolation.

The introduction of ultrasonic cavitations into the electrolytic liquid is easy since the electrolysis bath is also the ultrasonic bath and ultrasonic transducers can be attached to the bath externally. A mixture of sonic frequency should be used to avoid any occurrence of a dead sonic zone. The introduction of sonic excitation through cavitations enhances the production performance of plasma-assisted electrolysis.

Pulsed high-voltage DC supply with single polarity square wave from 5 KHz up to 100 KHz has been found to be beneficial for generating plasma at a much reduced voltage.

The distinct advantage of the under-liquid plasma enables ionised species migrate to the respective half cell and electrodes which will avoid and minimise re-mixing of the produced hydrogen and oxygen causing a reversion to water again and creating a hazardous, explosive condition. The oxygen is considered as a by-product which can be collected for use or it can be channelled to the combustion chamber if hydrogen is used as direct fuel for a combustion engine.

Water is the primary source material for hydrogen production, being economically available and of unlimited supply. It is a completely clean source material that produces no unwanted by-products.

The anode may be gradually losing its materials due to electro transportation, but if so, it will be a very slow process. In practice the polarity of electrodes can be reversed which reverses the materials transportation and deposition. Conductor materials which are inert to electro-chemical corrosion are a good choice to serve as electrodes.

A chemically conductive reagent may be added to water to increase its conductivity and a foaming agent added to enhance generation of bubbles. The electrolyte can be of acidic or alkaline base. The concentration of the electrolyte should be maintained at a steady level for best results. High electrolyte concentration increases liquid conductivity as well as productivity of gas bubbles but it might prevent the rising voltage required for discharge as the current flow between electrode will not be inhibited by the presence of bubbles. However, a very low concentration of electrolyte will favour dielectric breakdown of bubbles, as a lesser current will be carried by the liquid medium inbetween the bubbles. It has been found that either acidic or alkaline electrolyte with 0.02% concentration work extremely well in maintaining steady glow discharge with DC voltage ranging from 350 V to 1,800 V and a current from 100 mA to 800 mA.

Tap water has been used without adding any conducting reagent and it often works unexpected well, most likely due to present of impurity and high pH, in the plasma-assisted electrolysis where steady glow discharge occurs at around 450 V to 900 V and current around 200 mA to 350 mA. The power input requirement varies in accordance to electrode spacing, electrode and reactor configuration, electrolyte concentration and the structure of gas retaining arrangement. Again other plasma assisted method such as pulsed power input and ultrasonic cavitations etc. also help to lower the power input requirement.

The process is in general, conducted at one atmosphere pressure. An increase of pressure will slow down upward movement of the bubbles and raise the temperature of the electrolyte. Some increase in temperature in

the electrolyte is not detrimental to the generation of plasma. Water vapour bubbles provide the source materials and active environment for plasma discharge. In general, electrolyte temperature is well below boiling point as non-thermal plasma produces little heat. The temperature sometime rises quickly in the electrolyte due to occurrence of infrequent plasma arc and exothermic in the recombination of H⁺ and OH⁻ in quantity.

During the steady glow discharge, vigorous bubbles with yellow/orange/red colour light spots appear all over the plastic perforation. The light spots also appear widely on the electrode surface when the voltage is increased. On examination of the electrode and plastic cover sheet, no burn marks were observed. This proves that the plasma glow is non-thermal after an hour of glow discharge. The temperature in the electrode plate recorded with a thermal couple was around 50°C to about 90°C. The gas produced is composed mainly of hydrogen with some water vapour, which condenses quickly on cooling. The rate of hydrogen production is variable and energy conversion rate also fluctuated throughout the test. This is suspected to cause by the recombination of H and OH, which is affected by the electrode and reactor structure and configuration.

Hydrogen can now be produced with high voltage and low current, which is contrary to the conventional electrolysis system where a small reactor with a high rate of production is becoming possible. This has clearly demonstrated that the mechanism of producing hydrogen with plasma discharge is different from conventional water electrolysis in a number of ways. Steam and gas vapour produced due to heating of the electrodes (cathode) in short space of time are becoming an importance source of materials for plasma dissociation that also influence the productivity of hydrogen.

1.3 Experimental Procedure

1.3.1 A flow diagram for carrying out experiments in relation to this invention is shown in **Fig.28**.

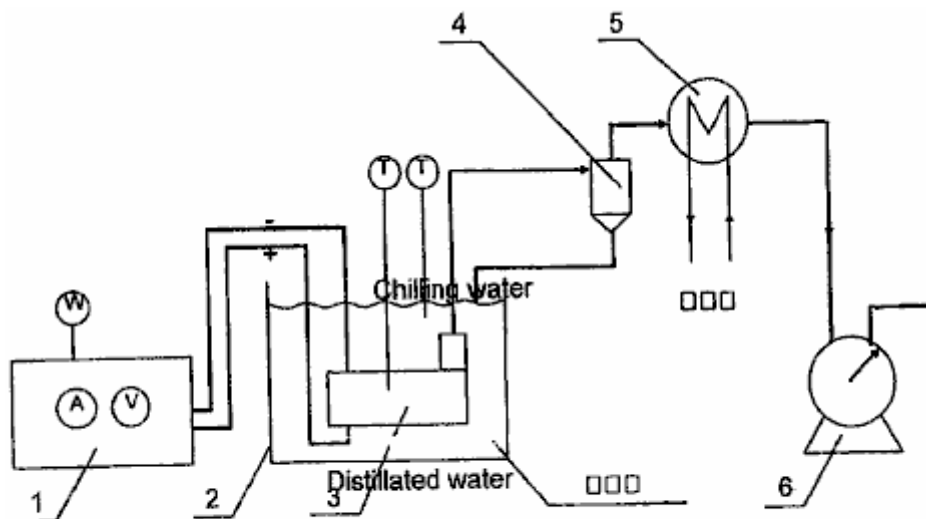

FIG. 28

The apparatus comprises broadly, a DC power source 1, liquid bath 2, reactor 3, gas and liquid separator 4, water chiller 5, and gas-volume measuring meter 6. Gas was produced by electrolysis which was catalysed by the plasma. Hydrogen gas was produced at the cathode and oxygen gas at the anode.

1.3.2 Equipment Function:

DC power source: provides high voltage DC.

Horizontal reactor: generation of non-thermal under-liquid plasma.

Gas and liquid separator: to separate liquid from gas and return as chilled liquid.

Chiller: to condense any liquid vapour admixed in the gas and return to reactor.

Gas-volume measuring meter: to measure the volume of gas flow.

1.4 Method and Operation of the Experiments

(1) The experiment is conducted in according to the occurrence of plasma discharge. Six different levels of voltage are selected to produce under-liquid plasma with same reactor for the generation of hydrogen. They are: 1350 V, 1450 V, 1550 V, 1650 V, 1750 V, and 1850 V. Each experiment lasts 30 minutes and the experiment is repeated three times under the same set of conditions. The data obtained are than averaged out.

1.5 Experimental Observations

Plasma discharge at 1,350 V is observed to have few and limited lighting illumination on the electrode in comparing with those vigorous, steady discharging over a much larger electrode surface at voltage 1,850 V. The corresponding current input is also very much reduced. It has been recorded that the temperature at the cathode electrode rises with time until it reaches about 90°C and gradually becomes steady. The colour of the plasma discharge appears to be orange and red and it's colour is greatly different from that of electric arc (plasma arc discharge) which appears to be sharp bright blue in colour.

Applicant also conducted experiments with the same equipment utilising the under-liquid plasma to transform methanol for use in hydrogen production. Applicant found that the plasma was efficacious in producing hydrogen gas from the methanol. CO and CO₂ gases were completely absent from the gas produced. This was unexpected. Without being bound thereby, Applicant believes that CO and CO₂ may have been absorbed by KOH which was added as a conductive agent to the electrolyte. Some oxygen gases were recorded before methanol was added to the electrolyte.

Applicant also conducted experiments with the same equipment utilising the under-liquid plasma to reform hydrocarbons for hydrogen production. Applicant found that the plasma was efficacious in reforming the hydrocarbons and producing amongst other things hydrogen gas.

Applicant also conducted experiments with the same equipment utilising the under-liquid plasma to treat diesel oil. The diesel oil was emulsified in water to disperse it through the body of liquid. After being subjected to plasma conditions near the cathode, a gas was produced that was smoky and resembled an exhaust gas emission that did not easily burn. Applicant established by means of these experiments that diesel oil could be reformed and also dissociated by the in liquid plasma with this equipment.

Reformation of hydrocarbon liquid and gas fuel, and hydrogen rich compounds for hydrogen production:

Water is one of the primary source materials, which serves as carrier, conductor and confinement to the bubbles space where plasma corona and glow discharge would take place when adequate electro-potentials apply across single, or multiple electrodes pairs. The hydrocarbon fuel methane (gas), methanol, diesel, gasoline, kerosene (paraffin), ethane, natural gas, LPG gas, bio-diesel etc. and hydrogen sulphur (H₂S) are also good source material for hydrogen production.

The majority world-wide of hydrogen production conventionally is by high-pressure steam reformation of methane. This requires high pressure and high temperature. The production plant is large and costly to set up. Storage and delivery in association with the production are an added cost for the supply of hydrogen gas. The importance of hydrogen as an alternative environmentally clean fuel is well understood. The upcoming fuel cell technology demands an economic and ready supply of pure hydrogen gas. To produce hydrogen with a small processor to enrich fuels for combustion engines and gas turbines will not only be reducing fuel consumption but it also reduces polluting emissions.

The proposed plasma reformation process can deal with both gaseous fuel and liquid fuel. The gas fuel will be bubbled into the reactor along with an inhibitor to slow down the upward flow of the fuel gas. Since the dissociation of the hydrocarbon fuel will be mainly achieved by plasma dissociation which is similar to the plasma-assisted electrolysis process, but with electrolytic liquid containing hydrogen rich compounds. In the case of liquid fuel, it can either form a mixture with water or be emulsified with water. The percentage of fuel in the mix depends on the type of fuel, its conductivity, boiling point, flammability and electrochemical reaction. The reformation is mainly due to partial oxidation either with the active OH⁻, O⁻, O₂, O₃ created by the plasma dissociation. At the same time, the hydrogen-rich compound such as CH₄ or CH₃OH will be dissociated directly with electron

collisions. Since carbon dioxide is a major by-product together with some other minor gases coming out from the impurity of the fuel, they will be separated by the conventional absorption method or the membrane separation method.

Transformation of hydrocarbon fuel by corona and glow plasma has been attempted by passing the hydrocarbon gas such as methane, natural gas, LPG and vaporised liquid fuel sometime mixed with water vapours through the plasma reactor. They have all been successful in producing hydrogen-rich gas through corona discharge at atmospheric pressure by subjecting methane, vaporised methanol, diesel fuel mixed with water vapour, by passing it through a plasma glow reactor, wire in tube reactor and reactor proposed by MIT plasmatron or other gas phase corona streamer reactor.

The proposed under-liquid plasma reactor has many advantage over the gas-phase plasma reactor as it is able to generate a steady plasma-glow discharge at a very much lower voltage, i.e. from 350 V to (rarely) 1,800 V with current in the range of 100 mA to 800 mA in water. The liquid medium will also permit the application of ultrasonic waves producing an effect which will enhance the generation of glow plasma and thereby increase the overall transformation process. Again, no external air or gas is need be introduced for the reaction. However, the hydrocarbon gas such as methane, natural, LPG or hydrogen sulphurs gas can be introduced to work in conjunction, and complementing the liquid fuel in the reformation process. The fuel gases will enhance plasma-discharge reformation and allow it to take place without having to rely on gas produced by electrolysis.

Those hydrocarbon fuel molecules which come in contact with the plasma-discharge, will be subjected to dissociation and partial oxidation depicted in the following:

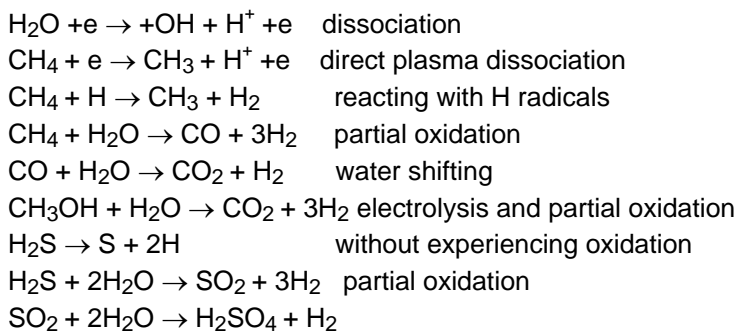

Endothermic catalytic conversion of light hydro-carbon (methane to gasoline):

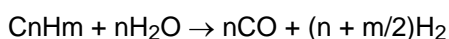

With heavy hydro-carbon:

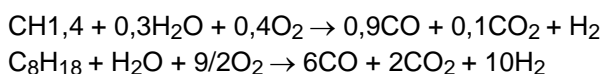

The hydrogen gas and carbon dioxide are collected. The CO₂ is separated by establish absorption or the membrane separation method.

The OH radical produced by the plasma dissociation will play an important role in oxidising the CH₄ to produce CO which would further be oxidised to become CO₂. The same applied to methanol CH₃OH and H₂S. The S is being oxidised to form SO₂ and further oxidising to become SO₃ and subsequently reacting with H₂O to produce H₂SO₄. This type of chemical reaction will be possible only with the encouragement of the highly chemical reactive and plasma catalytic environment. Not every CO will become CO₂ and sulphur particles may be observed in the precipitation.

REACTOR

There are number of reactors which can be used for the reformation of hydrogen-rich compounds. Reactors such as the wire in tube, tube in tube; single cell and multiple cell reactors; and the multi-electrodes without diaphragm separation. The tube in tube reactor and tower reactor with horizontal electrodes are suitable for treating both liquid and gas hydrocarbons and both at the same time. The anode and cathode are closely spaced with a gap distance ranging from 6 mm to 12 mm and are covered with dielectric gas-retaining and current-concentrating

construction on one side or both sides of the electrode. One important aspect of the reactor is having the construction, which will accommodate the ultrasonic transducer, which would induce proper sonic cavitations uniformly distributed throughout the reacting volume. The size, shape and arrangement of the electrodes can vary but its size would be restricted by the electric power available. A small reactor electrode plate is quite adequate for good uniform discharge and high productivity. The size of reactor plate use in most of the experiments is in the range of 16 cm^2 to 30 cm^2 . It is preferable that the non-discharging electrode has an electrode area larger than the discharging electrode with the dielectric gas-retaining construction. With sufficient power available, both the anode and the cathode electrode can be functioning as plasma discharging electrodes at the same time. This is particularly useful in the partial oxidation process.

In the case of an emulsified oil/water mixture, it is best maintained with ultrasonic excitation which at the same time generates transient micro bubbles which enhance the whole reactive process. Hydrocarbon gas may also introduce to the reactor to form air bubbles or trapped gas pockets for the ready formation of the plasma glow discharge. Since the oily hydrocarbon fuel is highly dielectric this would require a higher concentration of conducting reagent than that required for the plasma-assisted water electrolysis, in order to maintain a suitable level of current density for the discharge to occur.

Reformation of methane gas by the under-liquid non-thermal plasma is by bubbling the gas through the perforated horizontal electrodes of tower a reactor or a tube-in-tube reactor. Since the methane gas is to be oxidised by the plasma dissociated water molecule ($\text{OH}^- + \text{H}^+$) to form carbon monoxide and hydrogen gas ($\text{CH}_4 + \text{H}_2\text{O} \rightarrow \text{CO} + 3\text{H}_2$). The CO will be further oxidised to form CO_2 with oxygen derived from the plasma dissociated water molecule, releasing two more hydrogen atoms (H_2). The resultant gas is either H_2 or CO_2 with perhaps small amount of CO. The hydrogen gas will be collected with reasonable purity after the CO_2 or CO is removed by absorption or membrane separation. Since the methane gas may not thoroughly reform with one pass through the reactor, it is important to regulate the gas flow rate to ensure suitable resident time for the reformation or to have the methane gas recovered by the next round of reformation or to have the gas going through a series of reactors to made sure that the methane gas is fully utilised. The later case may not be energy efficient.

Reformation of methanol for hydrogen production can be achieved in the first place, by ordinary electrolysis or by partial oxidation. When CH_3OH is subjected to plasma discharge irradiation, it will react with the oxidising species and radicals dissociated from the water molecules. Conventional electrolysis will also contribute to the overall production of hydrogen gas. Reformation of methanol/water mixture will achieve better efficiency when plasma discharges is used in conjunction with ultrasonic excitation and cavitation. Several types of reactor can be adopted for the methanol reformation such as a tower reactor with horizontal electrodes, a tube-in-tube reactor, a transverse flow reactor, etc. These types of reactor offer very active oxidising species and hydroxyl radicals needed in the reformation.

Reformation of heavy oil such as diesel by under-liquid plasma discharge will be with emulsified liquid. The best way to maintain a thorough emulsification of diesel fuel and water is by ultrasonic excitation. Micro droplets of diesel will be encapsulated in the water. It is again observed that the conductivity of the emulsified liquid is very low as diesel oil is dielectric and current can only be conducted through the water film inbetween. This has rendered the need of more electrolytes added, especially as the diesel content increases. Bubbles are not easily produced by electrolysis due to its low current flow. It is therefore an advantage to either introduce gas to the reactor from outside or to produce ultrasonic cavitations in the liquid at the same time as the emulsification of the water/oil mixture. The tower reactor, tube-in-tube reactor and the transverse-flow reactor are all suitable for heavy hydrocarbon fuel reformation provided that an adequate ultrasonic transducer is properly located to ensure effective excitation and cavitations distributed throughout the liquid volume. A pulsed power supply will enhance the plasma generation and electrode heating will assist the generation of bubbles at the discharging electrode.

REDUCTION OF METAL AND MINERAL OXIDE PROCESS

Mineral refinement is an expensive and polluting process. To remove oxygen from the oxide, is either by reacting with higher electro-positive elements, which is uneconomic, or by exposing the metal oxide to C, CO, and hydrogen inside a high-temperature furnace such as the case in iron production. The electrolysis of a molten melt of Al_2O_3 or TiO_2 to extract pure metals Al or Ti respectively, consumes a large quantity of electricity, and requires the use of expensive refractory and electrode materials along with polluting emissions, render these two useful metals very expensive and inhibit their common application.

An under-liquid plasma reductive process to reduce oxide of ore or metals is proposed. The plasma discharge irradiation of the metal oxides in a highly catalytic environment, will cause interaction with the active hydrogen atoms produced by the plasma dissociation of water or methane or a methanol/water mix and introduced hydrogen gas together with the assistance of ultrasonic excitation would be sufficient in many instances to dislodge the most stubborn oxide.

It is reported that research is underway to extract Al from Al₂O₃ by electrolysis. Aluminium is electrode wired to cathode from porous Alumina anode electrode. The reduction of TiO₂ and Al₂O₃ by hydrogen plasma discharge is also being actively researched elsewhere with the aim of economically refining these two useful metals. A tube-in-tube reactor, or a wire-in-tube reactor can be used for this reduction process. These two reactors can be easily modified for continuous processing of either the granular form of the mineral or the metal oxide. The metal oxide will be exposed to the influence of highly active hydrogen atoms and subsequently the oxygen in the metal will be removed. This would not be a problem for those electro-positive elements but would present some difficulty for oxides such as Al and Ti.

The oxygen is strongly bonded with the parent metals such as Al₂O₃ and TiO₂ which cannot be reduced easily. This rudimentary horizontal reactor serves to demonstrate that metal oxide can be refined by exposing it in granular form to plasma discharge irradiation, ultrasonic excitation and in a highly reactive environment containing active hydrogen atoms. Additional hydrogen can be derived from the plasma dissociation of methane gas introduced to the reaction chamber where CO and atomic H are produced. Similarly by plasma dissociation of the methane water mixture that active hydrogen and CO₂ are also produced to supplement the reductive atomic hydrogen. Hydrogen gas can also bubble into the reactor and any excess will be collected and passed back to the reactor.

Reduction of Al₂O₃, TiO₂, TiF₃, TiO, AlCl₃ will be taking place in the following manner, where:

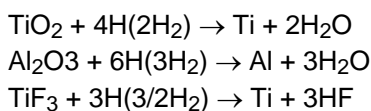

The alternative is to have:

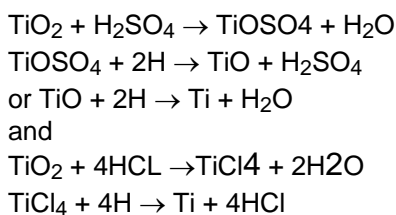

where TiCl₄ is ionic and is soluble in water

The above reaction is under the influence of a non-thermal plasma so that the oxide of ores or metal is subjected to a highly catalytic environment and comes into contact with the reactive atomic hydrogen whereby the oxygen will be taken out. To enhance the matter further, the whole reaction process is also subjected to sonic excitation. The fine particles in the colloidal suspension of the granular oxide will collide with each other and at the point of impact, the temperature will rise over 1,500°C to 3,000°C and local melting is reported. The high temperature and pressure of a collapsing sonic bubble will work in conjunction with the plasma glow discharge irradiating the oxide particles with atomic hydrogen with localised high temperature due to collision and cavitations implosion which in the end remove the oxygen. The refined metals will be in powder form down to nano size.

The other method of extracting and refining metals from their oxides is to subject the ionic solution of the metal such as AlCl₃ to an electrolysis process which is reported to have achieved efficiency of 3 KWh/Kg of Al. The whole process can be further improved with the plasma electroplating technique with the proposed under-liquid glow plasma discharge. The Al will be deposited on the cathode electrode. Part of the chlorine gas will come out from the anode side and will react with the active hydrogen to form Hcl.

The fine granular metal oxide is placed inside a horizontal reactor on top of cathode electrode. A close matrix separator membrane, used to prevent the metal oxide from crossing over, placed above and below the anode electrode is used to separate it from the cathode. The whole reactor is submerged inside an ultrasonic bath. Ultrasonic waves will penetrate the membrane separator to cause the granular metal oxide in colloidal suspension. The oxide will be subjected to the under-liquid plasma glow discharge irradiation and atomic hydrogen reduction. The percentage of metal oxide being reduced after a period of time is evaluated. Metal oxide of TiO₂ will be put to test. A methane/water mixture will be employed as the liquid medium which will produce larger amount of active atomic hydrogen serving as reduction agents.

DECONTAMINATION OF LIQUID

The problem of pollution is a major issue affecting every living being on this planet. A lot of effort has been expended by Governments, universities and private enterprises, seeking a comprehensive process to deal with a vast variety of pollution issues. Polluting gas emissions from industries and motor vehicles produce large quantities of CO₂ causing global warming; NO_x, VOC, and particulates causes cancer and smog; SO₂ causes acid rain. Decontamination of the gases discharged from industries is costly to achieve and what is urgently needed is a comprehensive and economical treatment process to reduce the overall treatment cost. Water contamination is another major issue. Contaminated water unfit for human consumption, enters the sea and kills marine life near the shore. Governments worldwide are passing stringent laws setting a pollution standard, which demands the development of efficient and economic ways to control pollutants. The present proposed invention is put forward as a versatile process, which can treat a variety of contaminants either separately or together.

Corona discharge and glow plasma discharge as non-equilibrium plasma has been developed for applications in the decontamination of a wide range of noxious chemical compounds and recalcitrant chlorinated organic compounds such as dichloro-ethane, pentachlorophenol, perchloroethylene, chlorom, carbon tetrachloride, organochlorine pesticides, endocrine disrupter, dioxin etc. It is also capable of sterilising tough microbial, bacteria and biological contaminants present in ground water such as *Cryptosporidia parvum*. Noxious gas emissions such as NO_x and SO_x can also be neutralised by passing them through the wet reactor, which includes the removal of particulates as well as the pollution emissions. This is mainly due to the ability of plasma to create a very reactive catalytic environment for those normally very stable and inactive compounds to be reduced, oxidised or neutralised by reacting with the OH* radicals, atomic hydrogen H⁺ and other oxidative species such as O⁻, O₂, O₃, H₂O₂ etc. present and is reported to have high efficiency especially in dealing with diluted contaminants.

Microbial bacteria is removed by both oxidations when they come in contact with the oxidative species such as O₃, O₂⁻, O⁻, H₂O₂, and OH*. At the same time, they are subjected to the electromechanical stretching of the cell wall, which weakens its oxidative resistance, especially when ultrasonic cavitations, implosions and shock waves created by pulse power, are incorporated into the reactive process. Again reports of over 99% sterilisation are not uncommon.

At the present, most of the treatment work is conducted in a gaseous environment, by spraying or vaporising the contaminated liquid over the plasma discharging electrodes, or by producing plasma discharge irradiating over the surface of a liquid which contains the undesirable contaminants, or by passing the polluted gas through a dry reactor sometimes mixed with water vapour or using plasma torch irradiation of the polluted object.

A surface water contact plasma glow discharge system has also been developed as a decontamination process under the name "Plasmate". Under water plasma by pulsed high voltage electric discharge with high current input to dissociate the water to produce H and OH* radicals to treat bacterial and microbial decontamination has also been reported as being successful.

The proposed under-liquid plasma is a low energy consumption system, which produces steady plasma by utilising the presence of bubbles. The voltage required for dealing with a wide range of liquids having variable electrolytic properties, ranges from 350 V to 3,000 V and current intensity ranging from 1 to 2 Amp/cm². It produces a highly reactive environment with a supply of oxidative radicals and reductive atomic hydrogen spread over a large volume of liquid, making it highly effective as a decontamination process, and one which is also both economic and easy to operate.

The under-liquid plasma has the advantage of being able to decontaminate several pollutants at the same time and it also has a very active gas and liquid interaction which makes it highly effective as a treatment process. Liquid waste, containing harmful chemical, bacteria, microbial, heavy metals, noxious gas, polluted air and odour can be treated in the same reactor simultaneously.

Recalcitrant organic chlorinated materials in water, which include dichloromethane, pentachlorophenol, chloroform and carbon tetrachloride, will either be oxidised or degraded to CO₂ and chlorine. While the pathogens in drinking water such as *Cryptosporidia* with thick phospholipids wall protecting the trophs is in the first place being stretched and weakened and subsequently broken down by the oxidising species. Some of the oxidative species such as OH radicals, O⁻, O₂⁻, and O₃ are present in quantity and are more active than chlorine and other mild oxidants. It has the advantage that no chemical is needed as an oxidation agent, which can sometimes result in secondary pollution.

Heavy metals in dilute solution, can be extracted or removed through a simple electrolysis process by turning the metal to hydroxide which could then be removed by filter. Soluble metal ions can also be extracted by deposition on to the cathode electrode, which can be further facilitated by the plasma electroplating process owned by the inventor, and which uses the same under-liquid bubble plasma process.

The treatment of NO, SO₂ and particulates is to pass the polluted gas through the reactor where the particulate will be removed and the NO is either oxidised to become NO₂ or NO₃ by O⁻, or O₃. It can also be reduced to N by the active hydrogen. NO₃ will react with water to become nitric acid. NO₂ is not considered to be a noxious gas. SO₂ reacting with O₃ or oxygen radical to form SO₃ can be easily oxidised and then react with water to become H₂SO₄ (sulphuric acid). When the said gas is introduced to the reactor it can be utilised as a gas bubble for plasma discharge especially when this gas bubble is collected or retained near the electrodes.

The effectiveness of non-thermal plasma discharge in treating carcinogenic organic compounds and pollutant gases is well established. Removal or reduction of the amount of heavy metals, arsenic and mercury to an acceptable safe low concentration level from or in water, have been successfully carried out by a simple electrolysis process. The extraction efficiency is further improved by the presence of an under-liquid plasma discharge where some of them will readily react with the OH radicals to become metal hydroxide or to be deposited by the very active plasma electroplating (deposition) method which has been adequately proven as a useful technique.

Further experiments in this area are unnecessary. Adequate information can be drawn upon from much research work which already been carried out. Concentrated effort has already been used to search for a better way of generating steady plasma glow discharge under-liquid by utilising the bubbles which will enable the manufacturing of a simple and economic reactor which requires only low power input and which will work well in treating a wide scope of contaminants.

Sterilisation of drinking water at municipal scale can be simplified by adopting the under-liquid plasma discharge which will effectively neutralise and degrade carcinogenic organic compounds in the water by creating the dissociation and active catalytic environment which encourages the breakdown of the inert chemicals and at the same time subject it to the active reductive and oxidative radicals. The heavy metals dissolved in the water will also be removed or reduced in the same time through the plasma electrolysis and electroplating as described previously. The biological contaminants will be sterilised by the highly oxidative environment existing during the glow discharge. The effectiveness of the combined treatment to produce potable water fit for human consumption is further enhanced by the adoption of ultrasonic cavitation and shock waves with a pulsed power supply.

The entire sterilisation process does not require any added chemicals such as ozone, chlorine or any electrolytic additive. The impurity in the pre-treated liquid will be adequate to serve as conductor for the under-water plasma discharge to take place. Any excessive ozone, which has not been used up in the oxidation process during the plasma discharge, will be easily neutralised by the presence of active hydrogen atoms. Hydroxyl radicals (OH) are one of the most aggressive oxidising agents, which being produced in quantity will do most of the useful work. There will be no chlorine remnant left in the water, as it is unnecessary.

The under-liquid plasma technique will be useful in food industries for low temperature sterilisation and removal of odour. The same method may also find its use in the paper-making industry in fragmentation and de-lignification of the fluidised pulps, treating the highly polluted discharge, and treating fabrics and dyes in the textiles industry.

There are several types of reactors which can be employed in the decontamination process. The separation membrane diaphragm in the wire-in-tube and tube-in-tube reactor is no longer required. Other reactors such as the transverse-flow reactor and the tower reactor can also be adopted.

The reactor can be arranged in such way that the plasma discharge occurs either at the cathode or at the anode provided that a good gas-trapping cover is provided on the electrode. Since much of the decontamination action relies on the presence of strong oxidation agents such as hydroxyl radicals, atomic oxygen, ozone, singlet oxygen and hydroperoxyl radicals, plasma discharge on the side of anode electrode enhanced with the gas retaining cover will cause the formation of said species represented by the following equations:

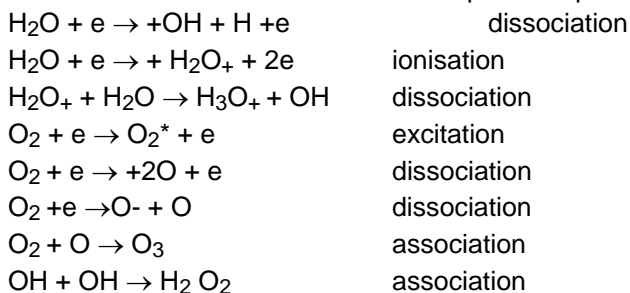

Some chemical contaminants can only be broken down by reduction with active atomic hydrogen, which would require plasma discharge at the cathode electrode. In the tower reactor (**Fig.7**) and transverse-flow reactor (**Fig.6**) it is possible to have the gas-retaining cover on one side of electrode facing the side of the opposite electrode with the gas-retaining covers, so that an alternating zone of oxidation and reduction is created in the reactors to deal with a variety of contaminants.

Production of hydrogen by plasma dissociation of water molecules is the result of electron collisions, which is different from the conventional electrolysis, which separates the dipole water molecules by electro-induction. They also have different sets of requirements to dissociate water molecules for the production of hydrogen:

Conventional electrolysis	Plasma glow discharge under water, according to the present invention
1. Low voltage and high current density	High voltage and relatively low current density
2. High concentration of electrolyte (up to 25% KOH)	Low concentration electrolyte (0.01% KOH) low electrolytic requirement
3. Avoid bubble attachment to the electrodes	Bubbles smothering the electrodes is welcome to create a dielectric barrier.
4. Electrode space distance is not restricted.	Electrode space distance has to keep close as far as possible.
5. Water molecules is split by induction	Water molecules are dissociated by electron collision.
6. Large production unit is required for efficiency and productivity	Small production unit favours the decentralisation of production.

The reactors and gas-trapping and retaining structures enclosing the electrode is made of perspex plastic. No sign of burning is observed in the plastic covering plate directly over the discharging electrode and the light emission is an orange/red colour (burning of hydrogen) which is distinctively different from the plasma arc which is bright blue colour when the voltage is brought beyond the glow discharge voltage level. A burn mark will be observed after plasma arc discharge. This proves that the plasma glow discharge with it's orange yellow colour, is non-thermal in nature.

Applicant also conducted experiments with the same equipment utilising the under-liquid plasma to sterilise mulberry juice. Applicant found that the plasma was effective in reducing the bacterial count and the mold colony count in the juice. After 40 minutes the counts of both bacteria and mold had been reduced substantially to less than 100 per ml. This demonstrates that the invention could be used to sterilise potable water, waste water, food, and liquid food and others.

CONCLUSION

A further advantage of the method described above is that plasma can be generated with relative ease within bubbles in the aqueous medium. It does not require excessive amounts of energy and can be done at atmospheric pressure. It certainly does not require a vacuum chamber.

A further advantage of the invention is that it provides a method of treating aqueous waste which contains components that cannot be neutralised or otherwise rendered harmless by the addition of chemicals to the liquid.

It will of course be realised that the above has been given only by way of illustrative example of the invention and that all such modifications and variations thereto as would be apparent to persons skilled in the art are deemed to fall within the broad scope and ambit of the invention as herein set forth.

Figures which are included in the patent application but which are not directly referenced in it:

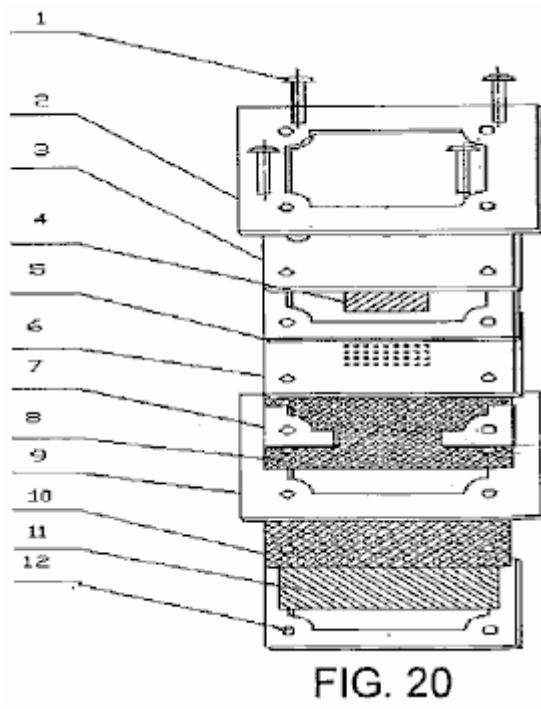
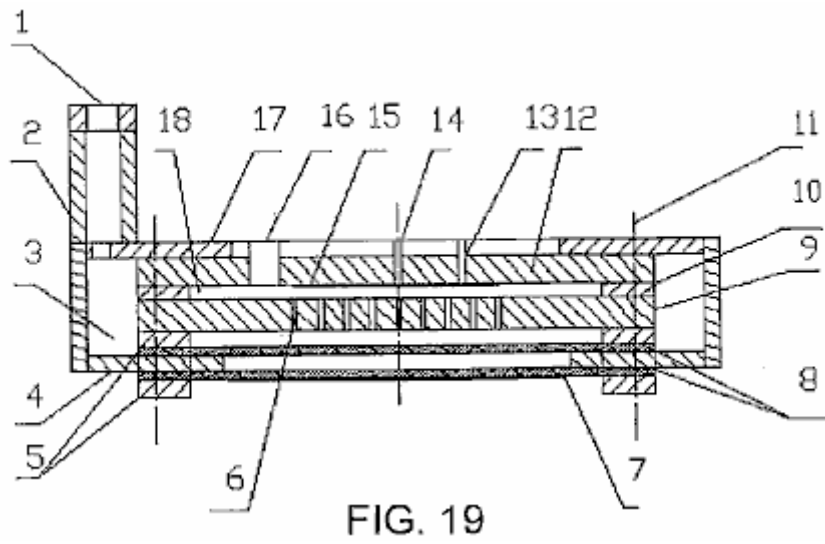

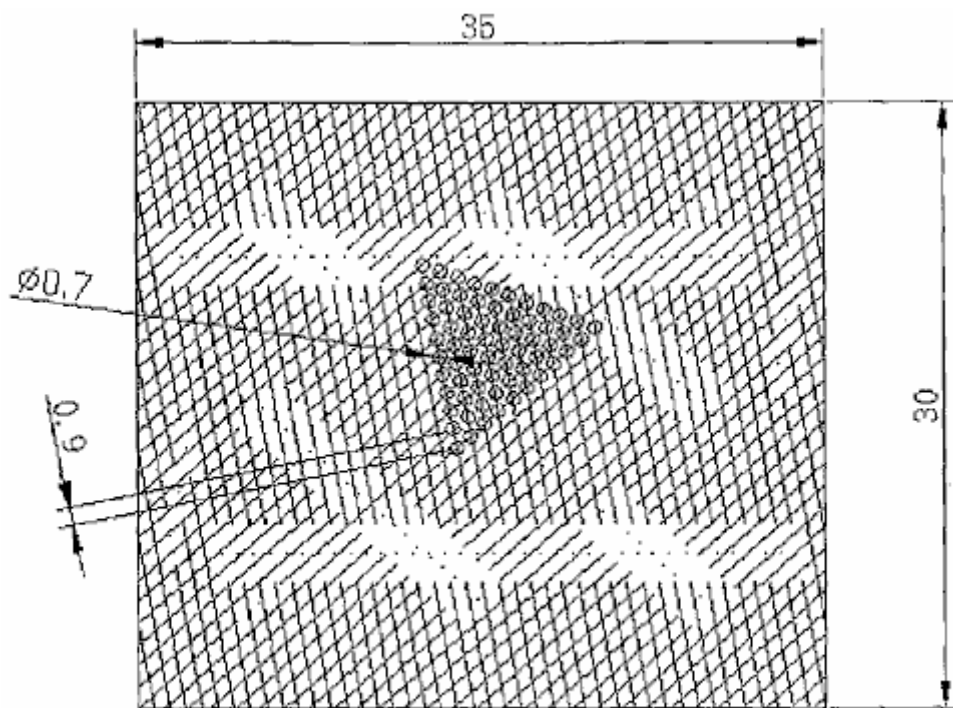

FIG. 21

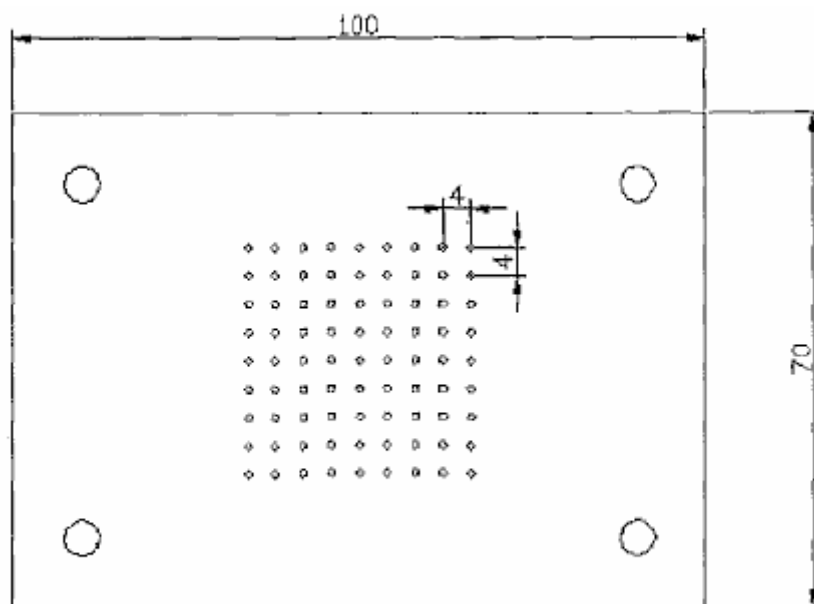

FIG. 22

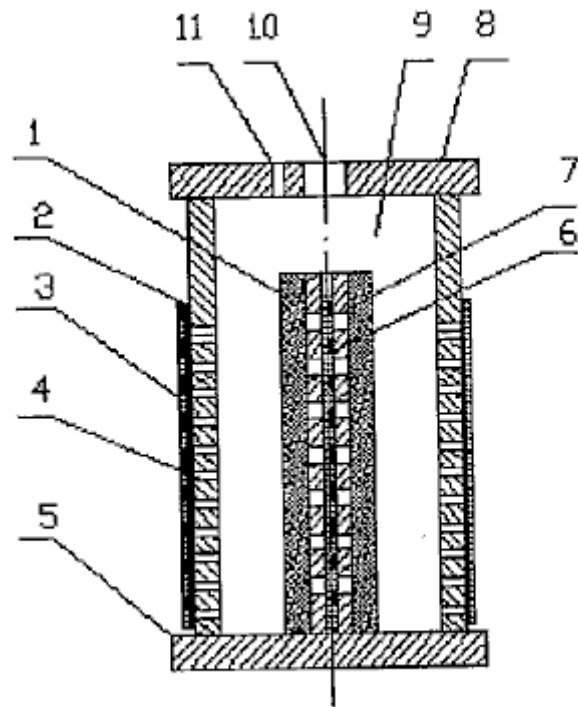

FIG. 23

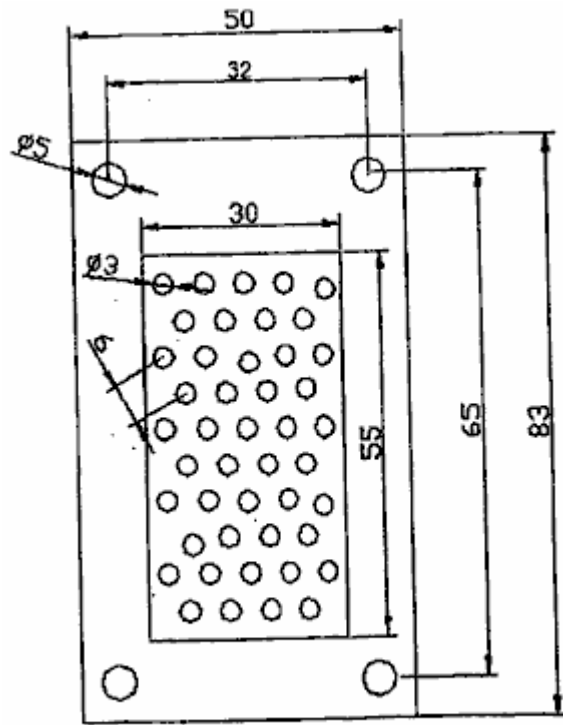
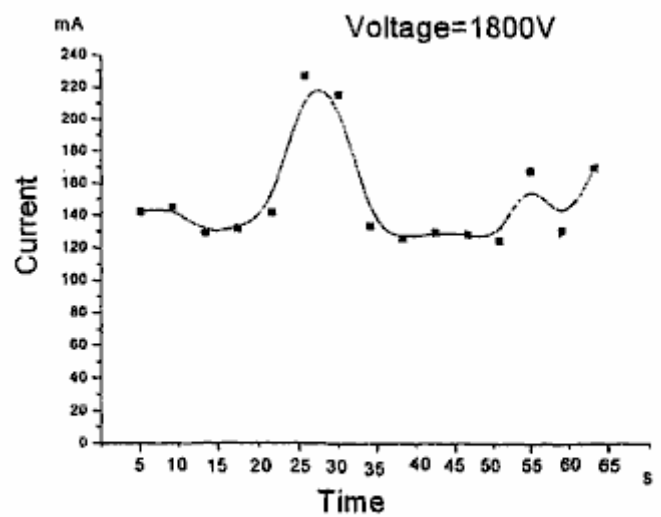
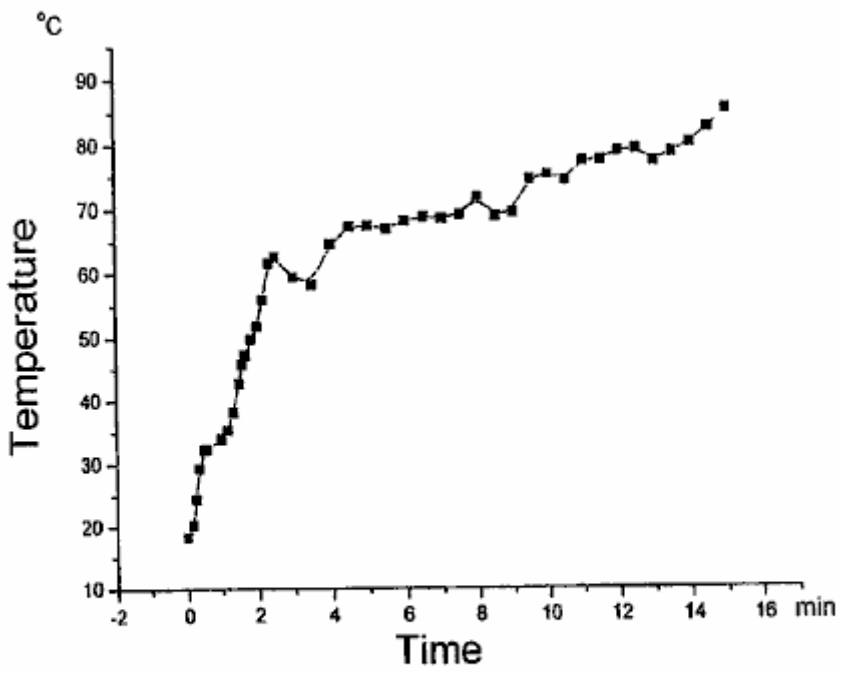

FIG. 24



Glow discharge at stable 1800V voltage input

FIG. 26



Temperature measured in the cathode electrodes

FIG. 27

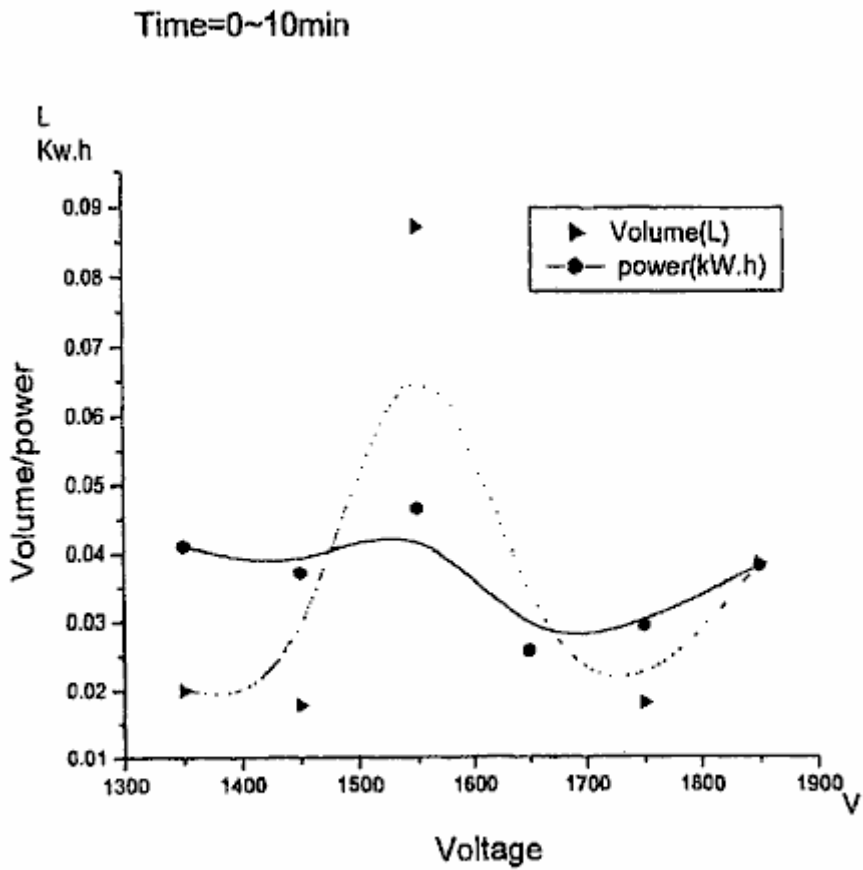

FIG. 29

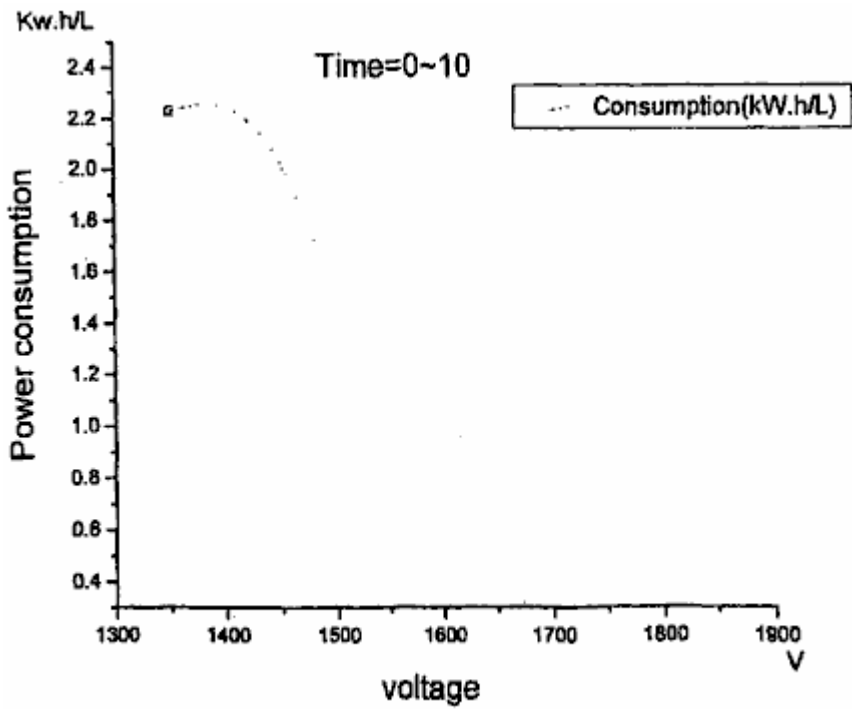

FIG. 30

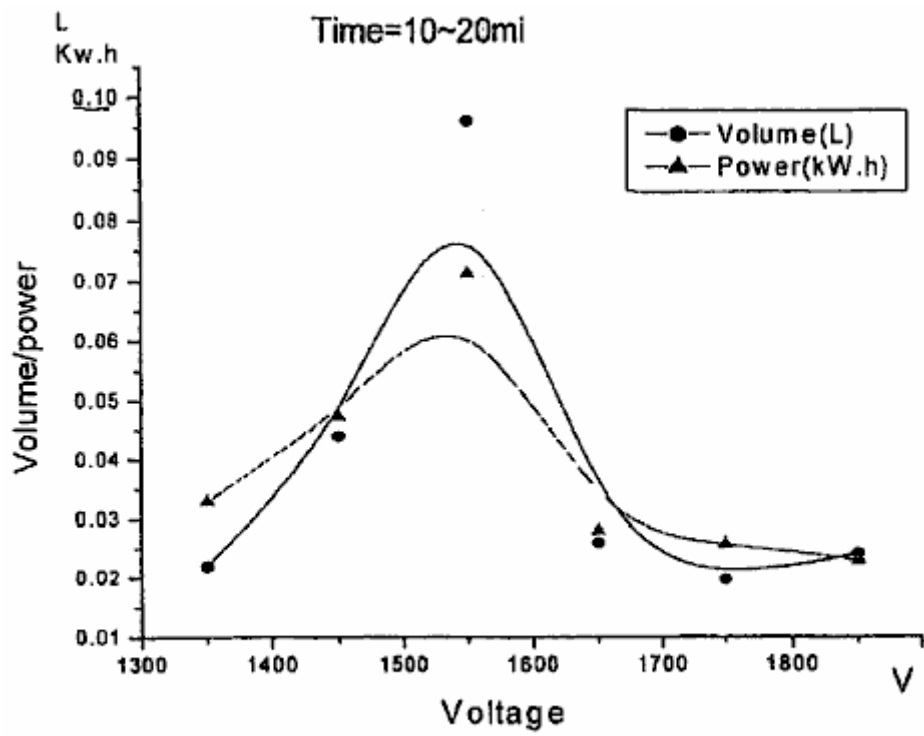

FIG. 31

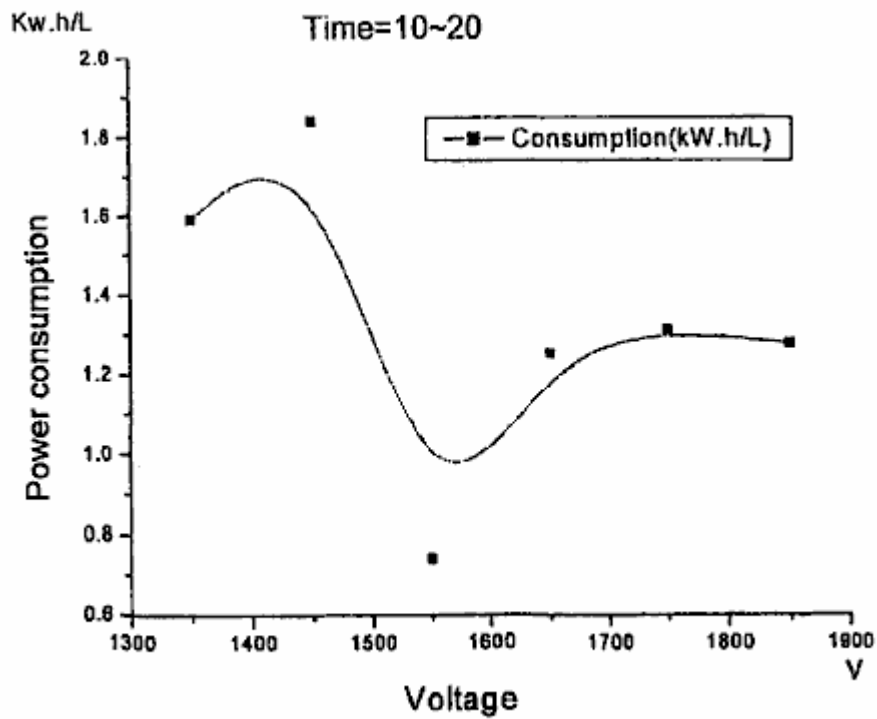

FIG. 32

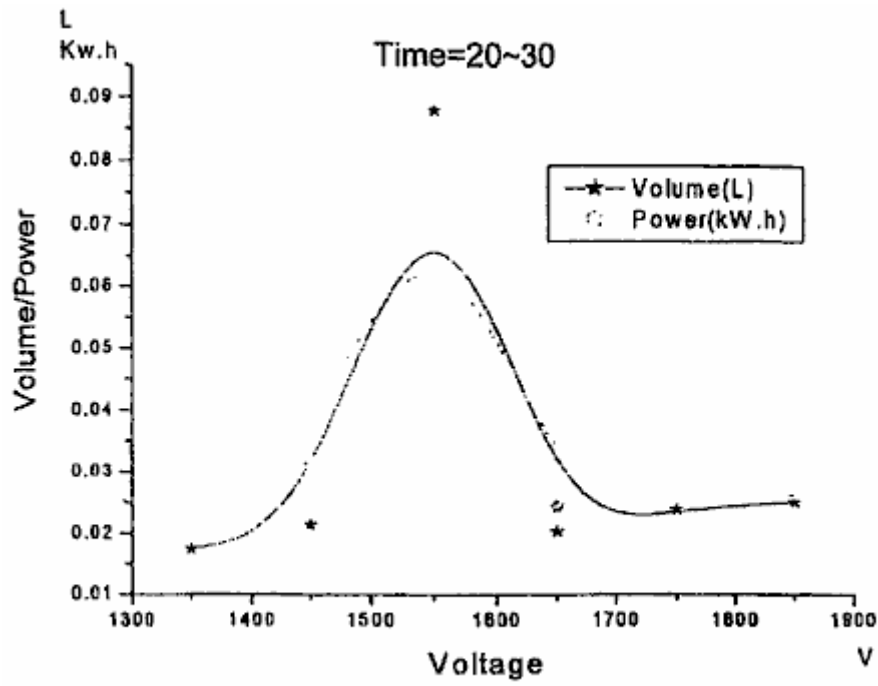

FIG. 33

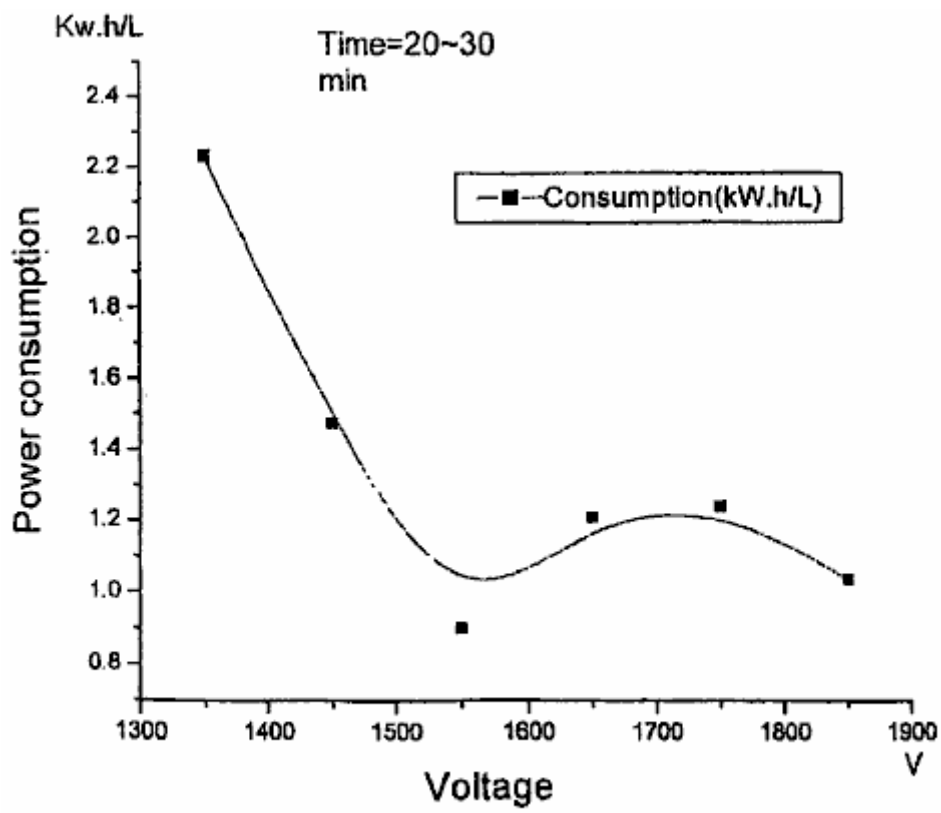

FIG. 34

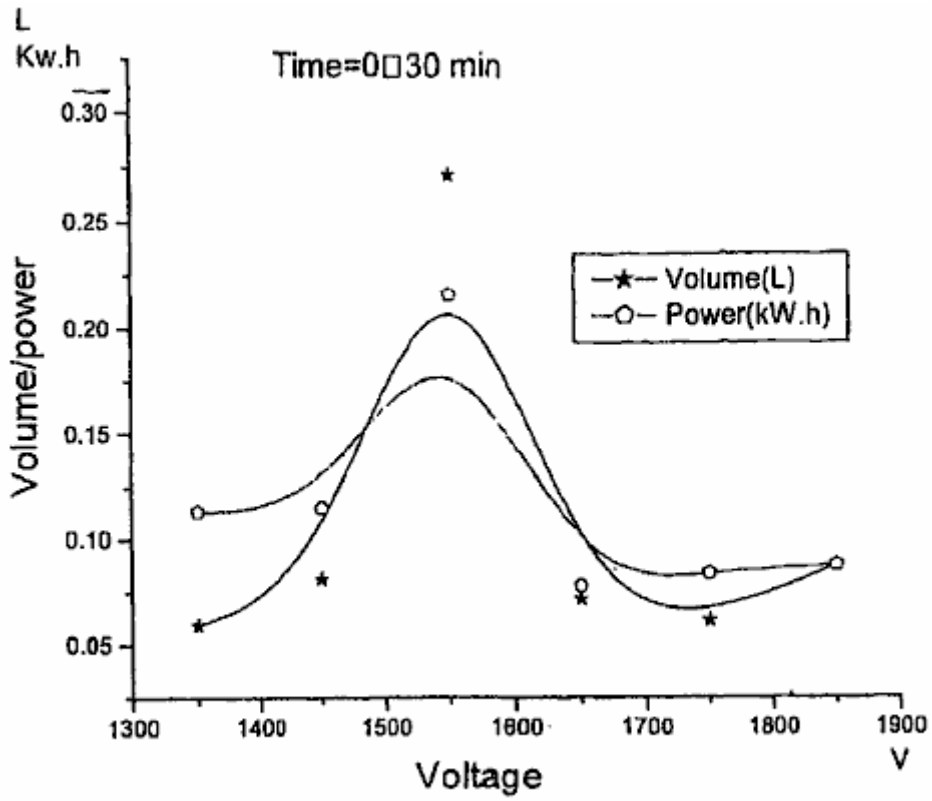

FIG. 35

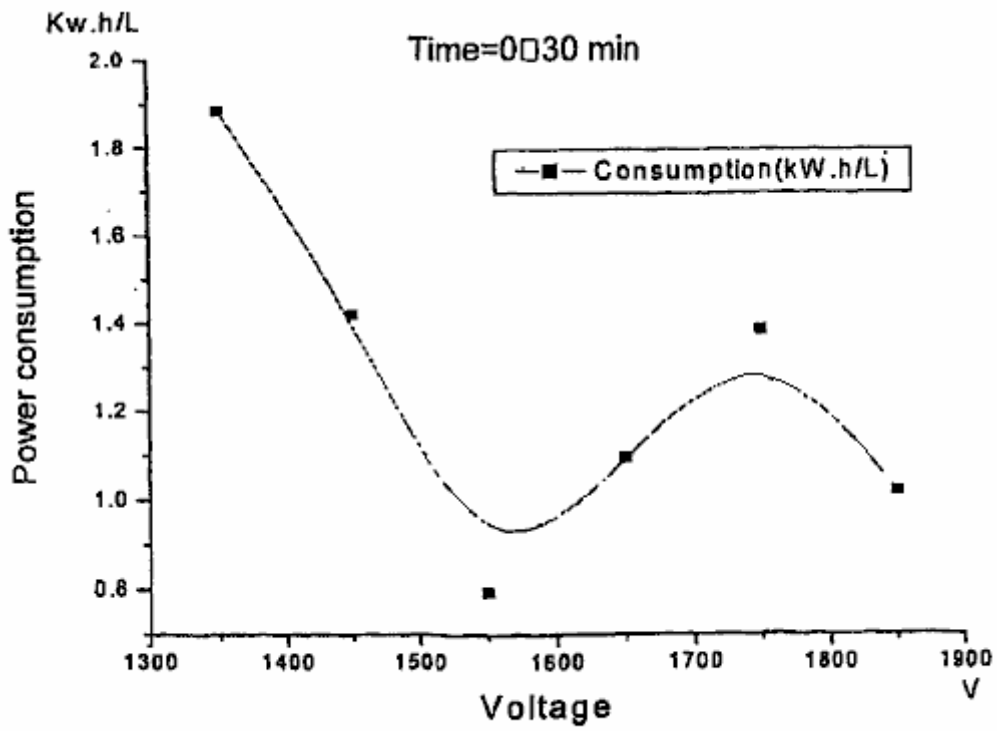

FIG. 36

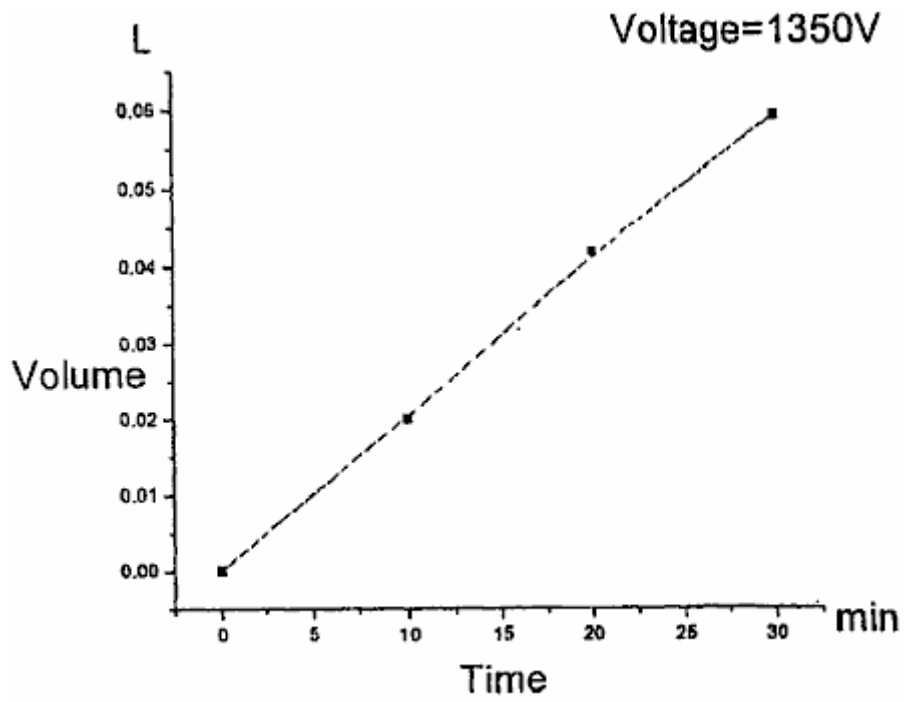

FIG. 37

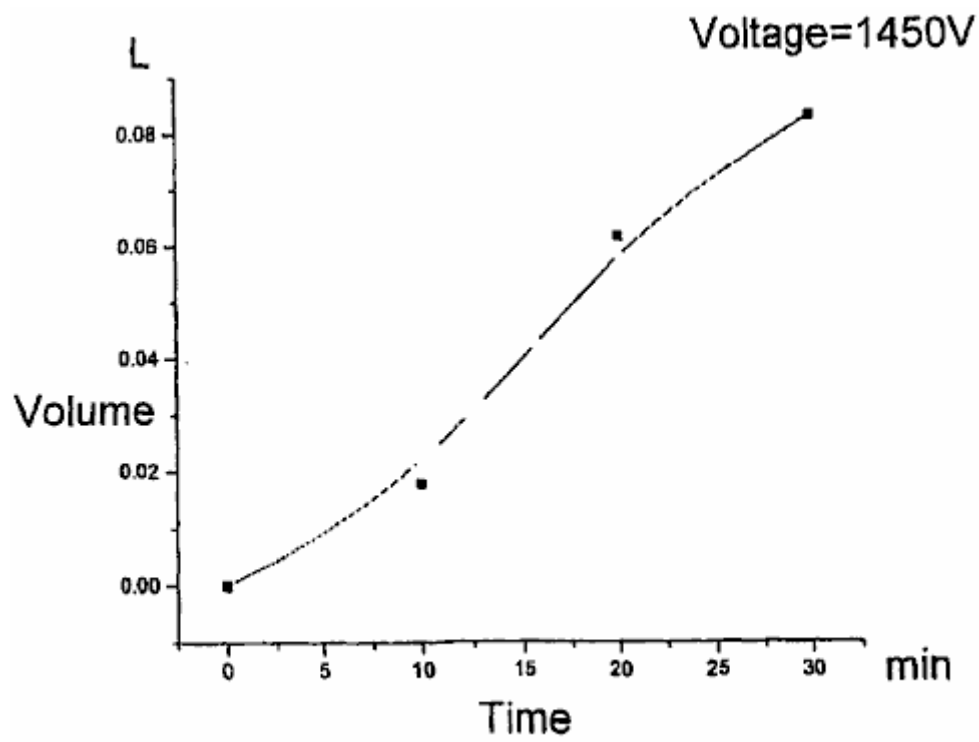

FIG. 38

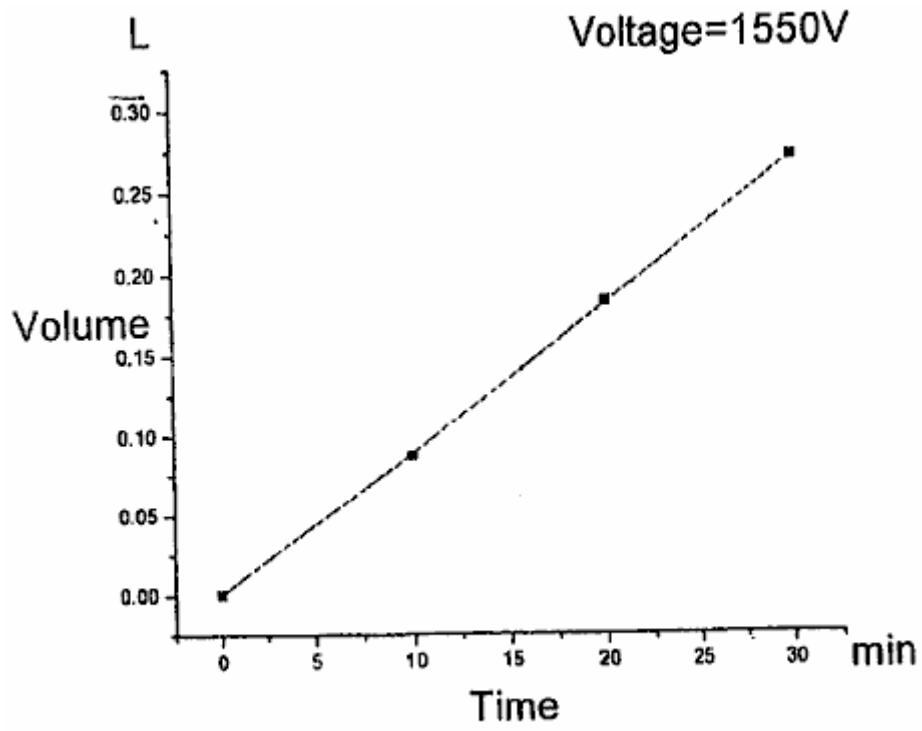

FIG. 39

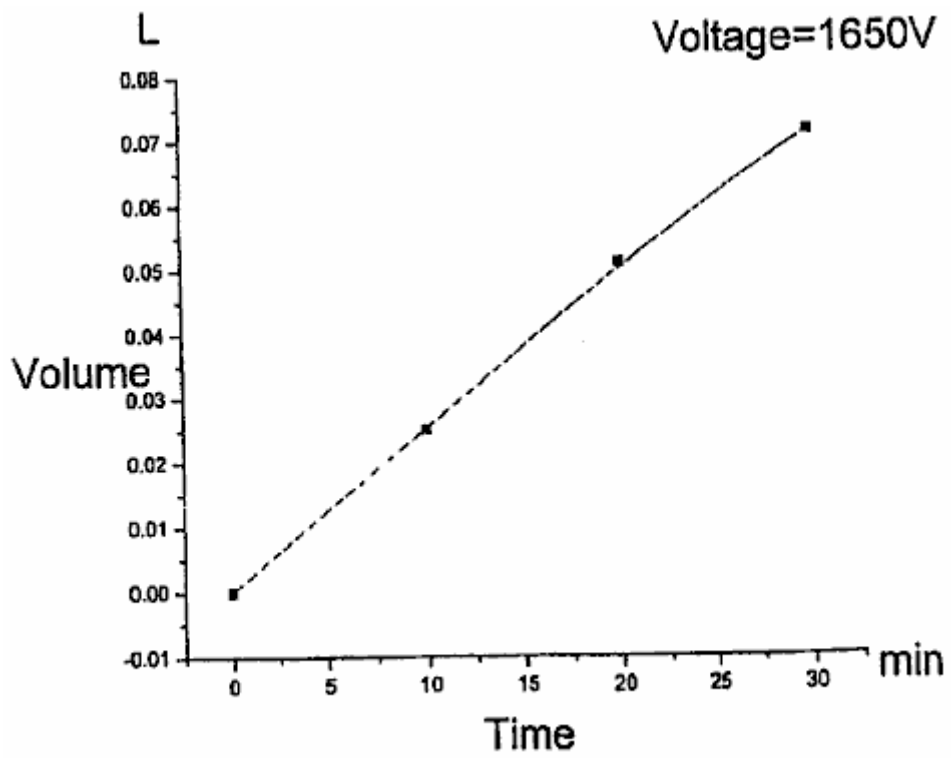

FIG. 40

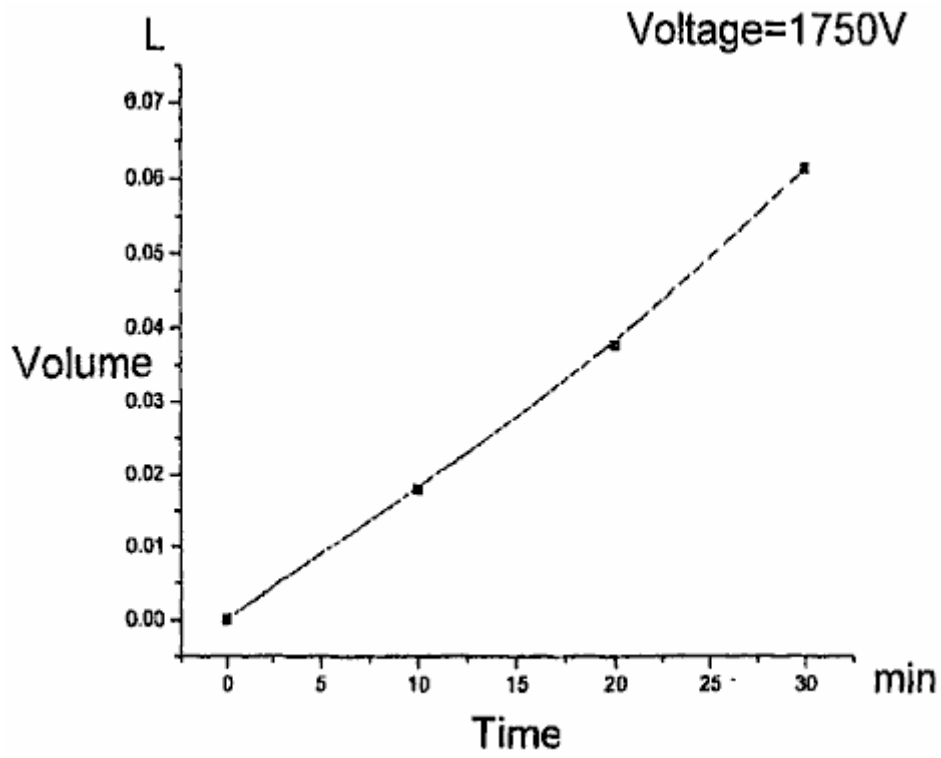

FIG. 41

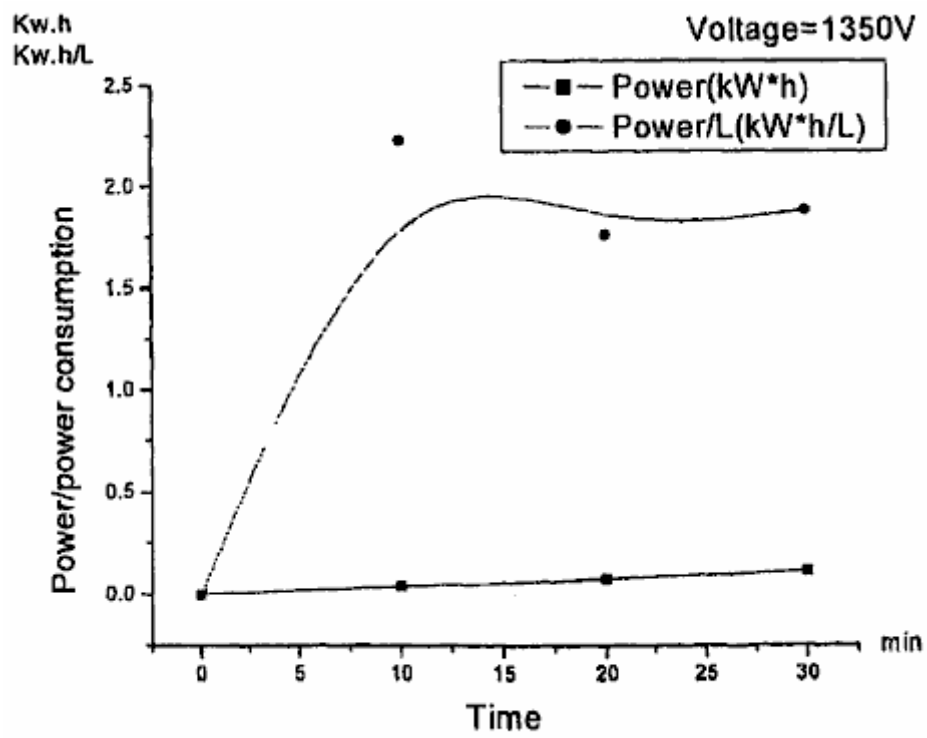

FIG. 42

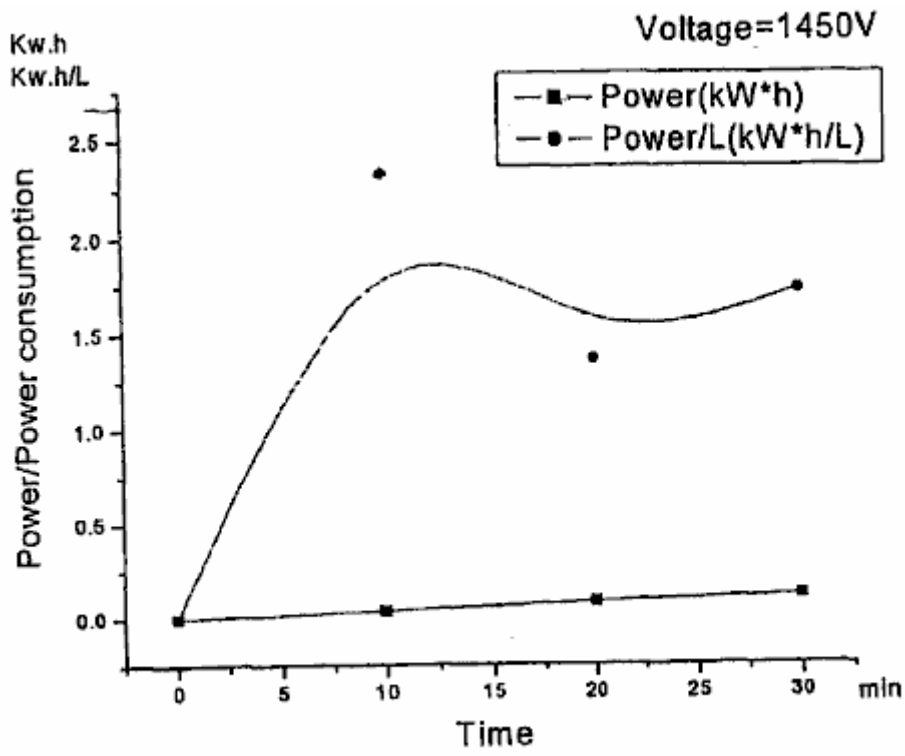

FIG. 43

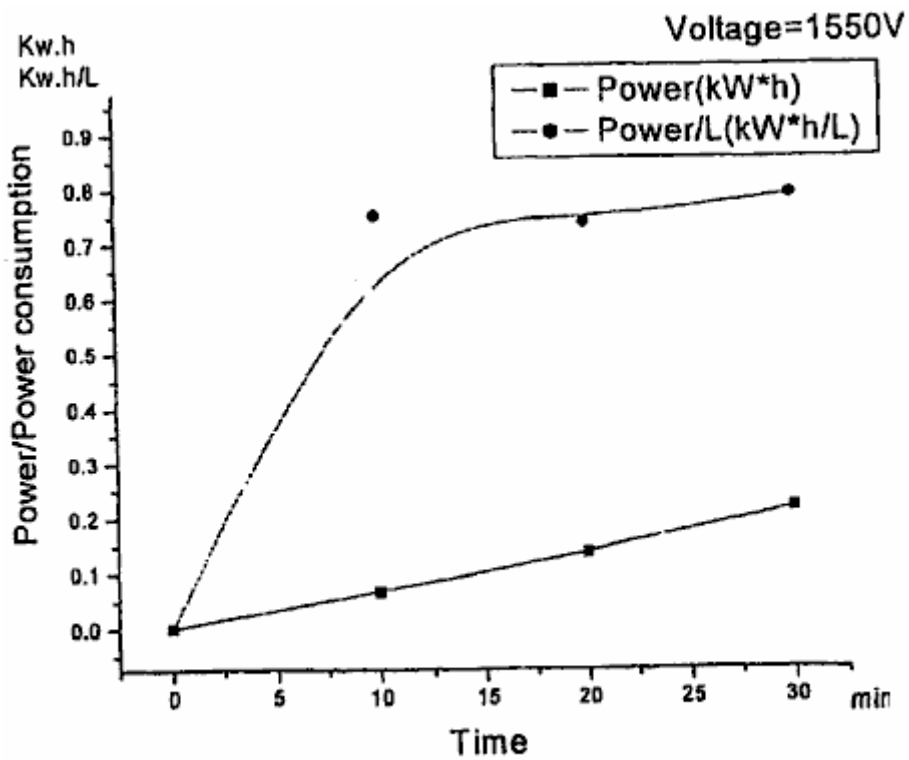

FIG. 44

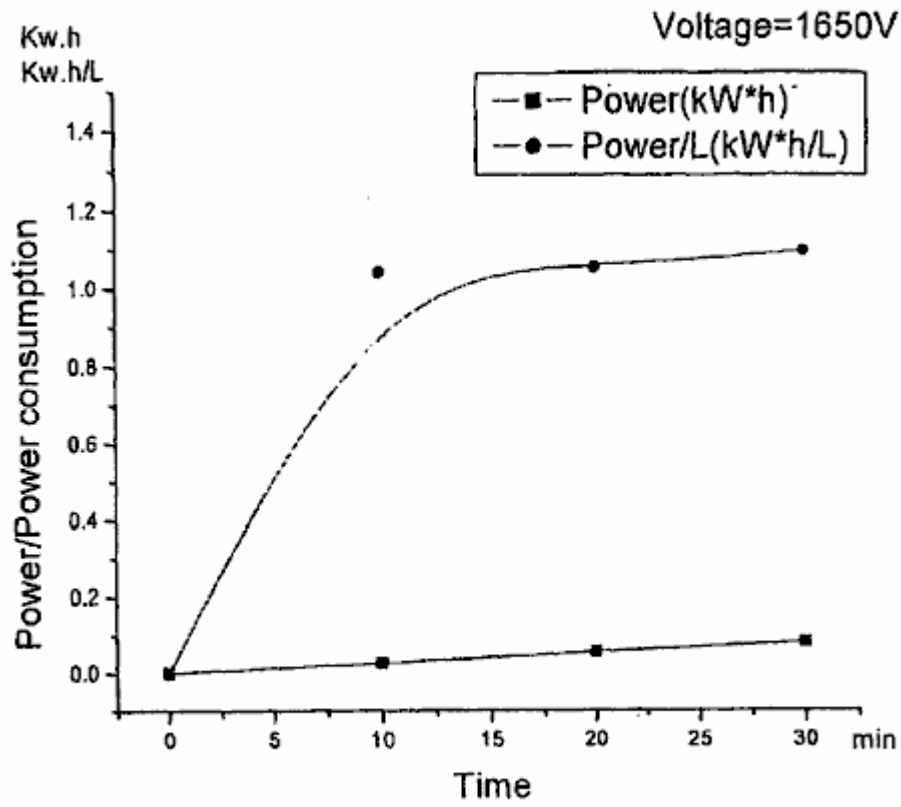

FIG. 45

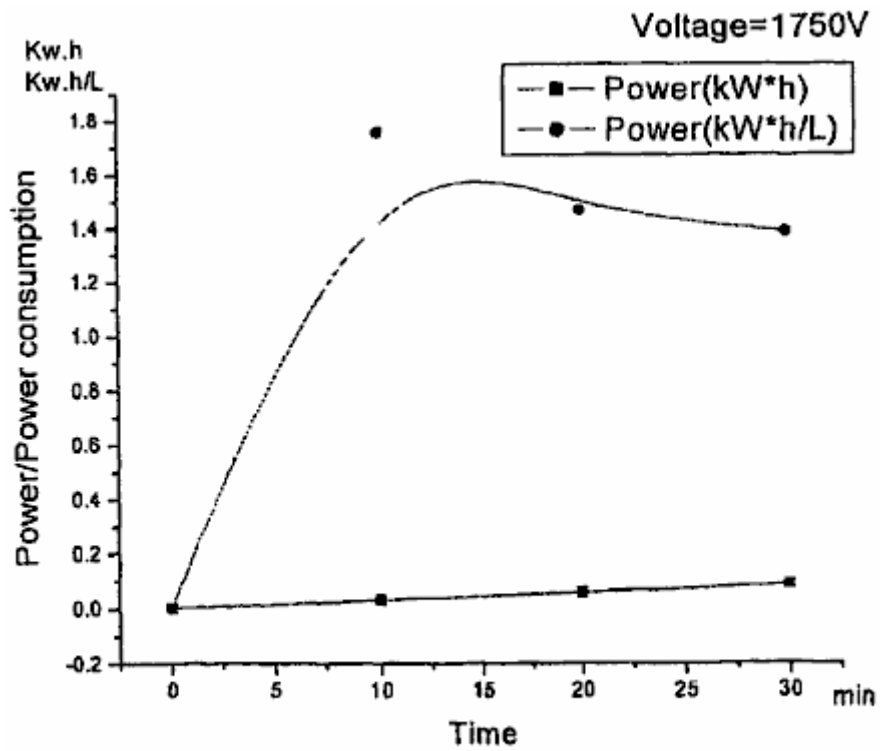

FIG. 46

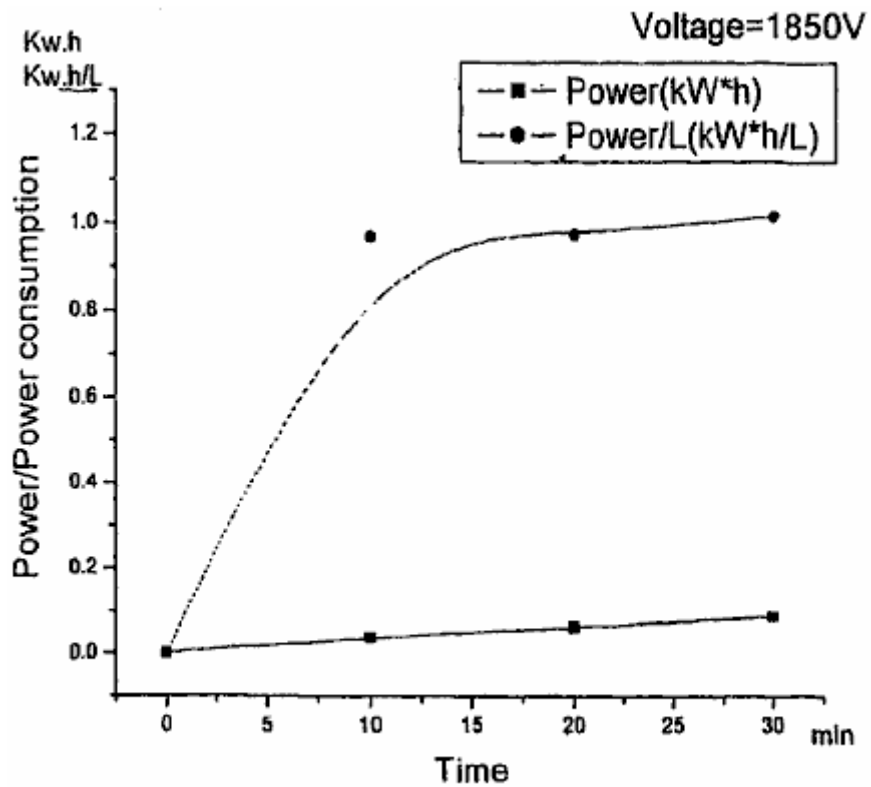

FIG. 47

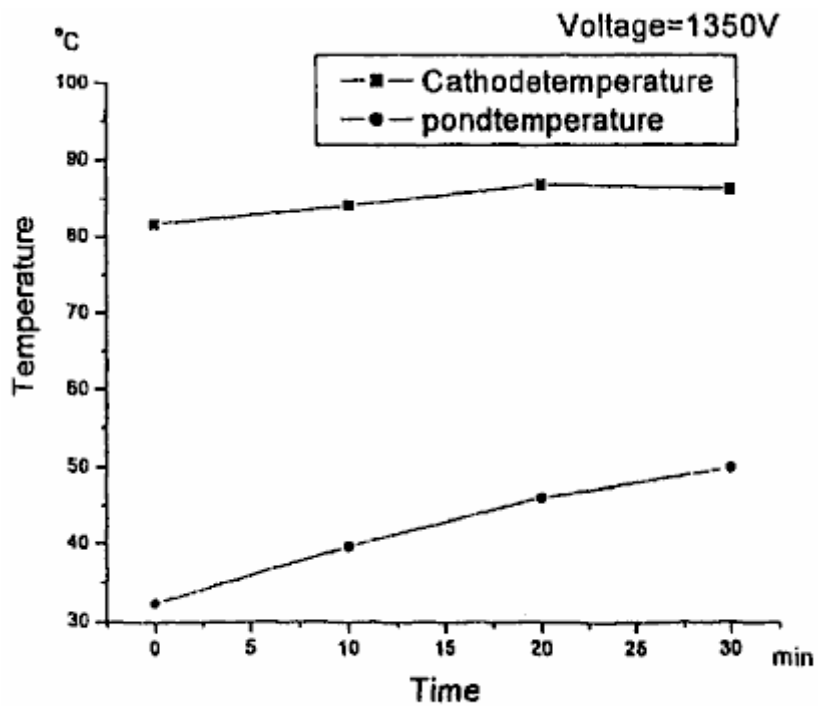

FIG. 48

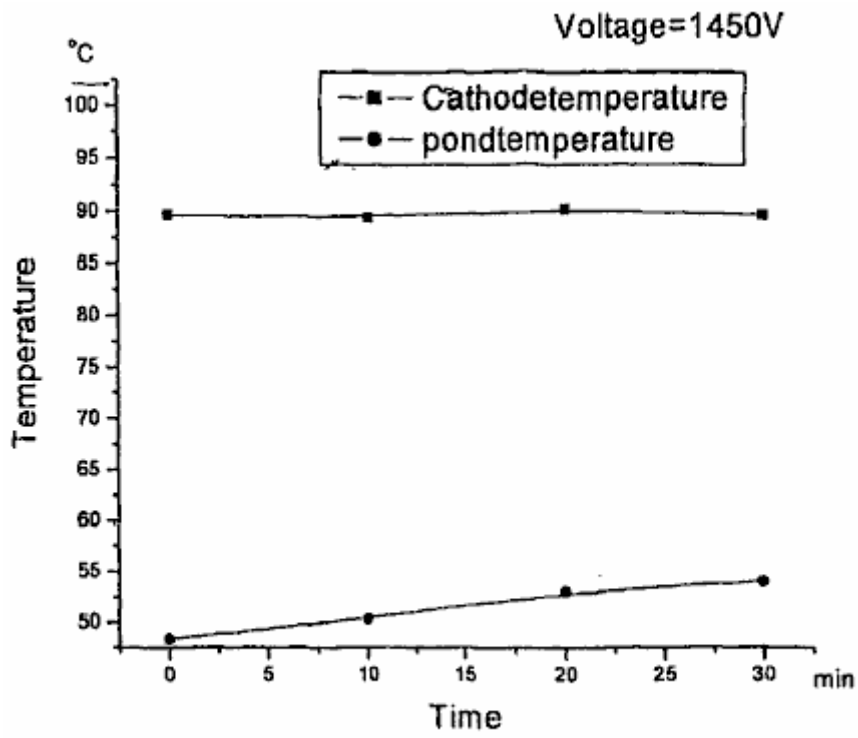

FIG. 49

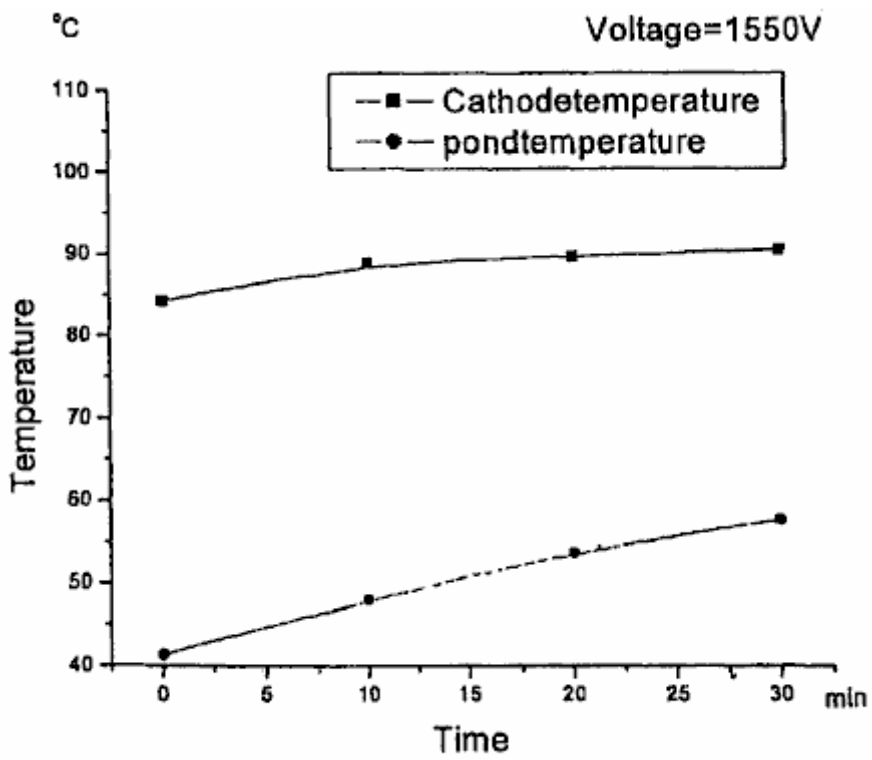

FIG. 50

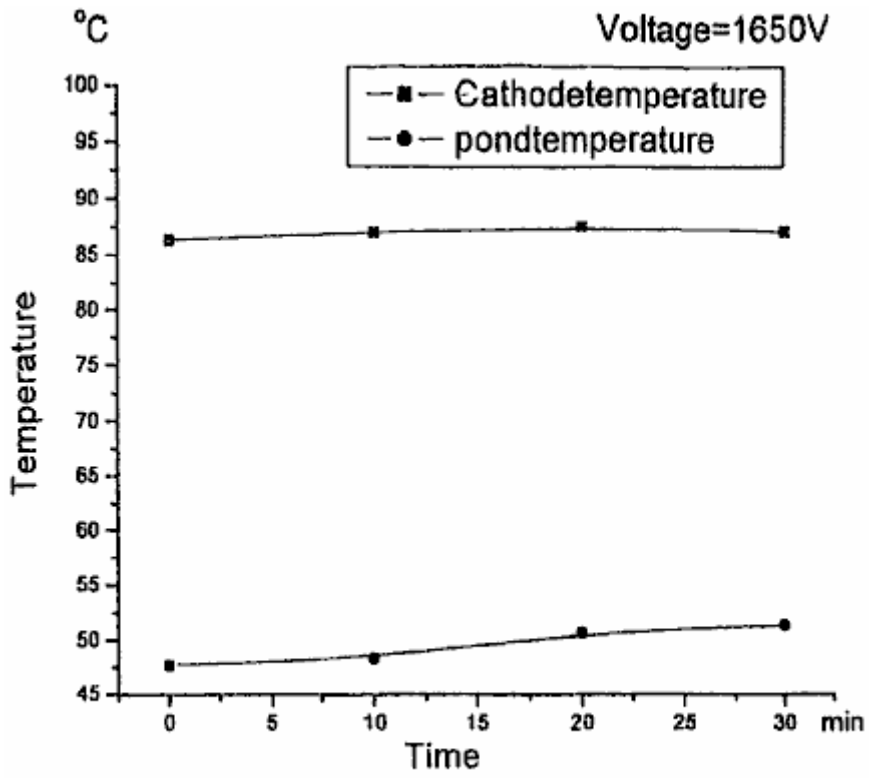

FIG. 51

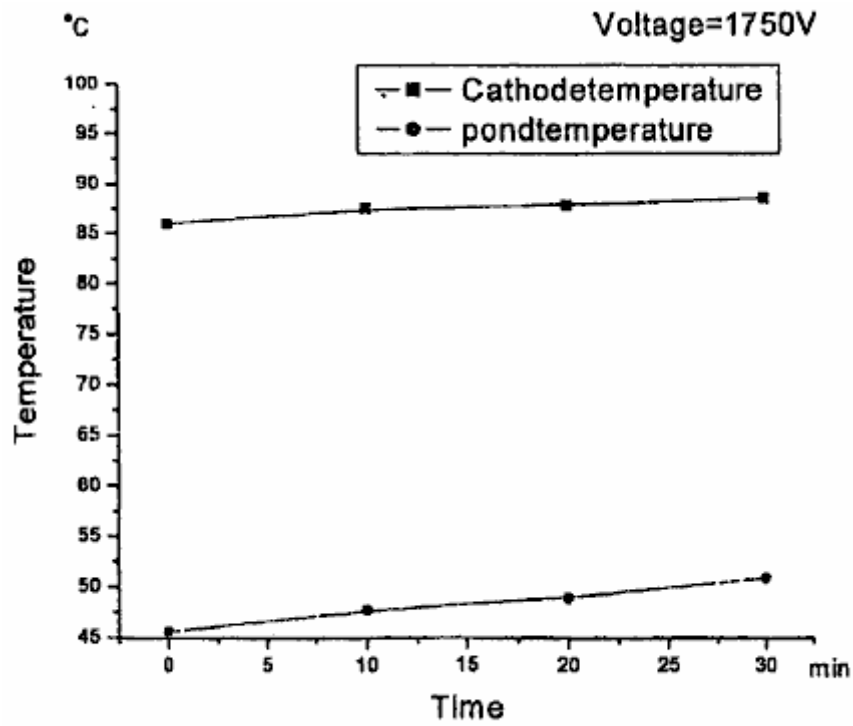

FIG. 52

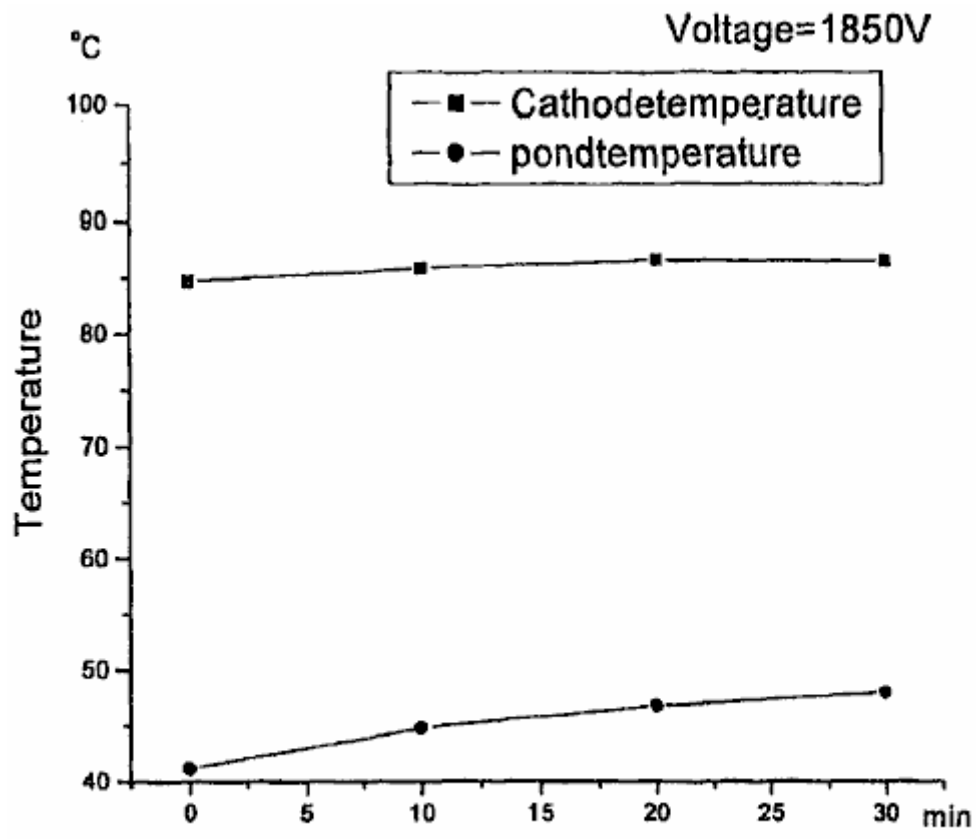

FIG. 53

Juan Aguero's Water-Fuel Engine

Patent Application EP0405919 1st February 1991 Inventor: Juan C. Aguero

WATER-PROPELLED INTERNAL-COMBUSTION ENGINE SYSTEM

Please note that this is a re-worded excerpt from this patent application. It describes a method which it is claimed is capable of operating an internal combustion engine from a mixture of steam and hydrogen gas.

ABSTRACT

This is an energy-transforming system for driving, for instance, an internal combustion engine which uses hydrogen gas as its fuel. The gas is obtained by electrolysing water on board and is then injected into the combustion chambers. The electrolysis is carried out in an electrolytic tank **15**, energised with electric current generated by the engine. The hydrogen passes from a reservoir **23**, via collector cylinder **29**, to carburettor device **39**. The hydrogen is then fed into the engine together with dry saturated steam and at least part of the hydrogen may be heated **51** prior to admission. A cooler and more controlled combustion is achieved with the steam and furthermore relatively lesser amounts of hydrogen are required. This is probably caused by the steam acting as a temperature moderator during admission and combustion of the hydrogen and additionally expanding during the expansion stroke.

FIELD OF THE INVENTION

The present invention refers to energy-converter systems, in particular related to an internal combustion engine fuelled by hydrogen gas, i.e. wherein the main propellant admitted to the combustion chambers is hydrogen. More particularly still, the present invention refers to method and means for obtaining hydrogen gas in an efficient and reasonably economical manner, and for supplying the gas to the combustion chambers under conditions for controlled ignition and optimum energy conversion. The present invention also refers to means and method for running an internal-combustion engine system from an available, cheap and non-contaminant hydrogen containing matter such as water as a fuel supply.

In general, the invention may find application in any system employing internal combustion principles, ranging from large installations such as electricity works to relatively smaller automobile systems like locomotives, lorries, motor-cars, ships and motor-boats. In the ensuing description, the invention is generally disclosed for application in the automotive field, however its adaptation and application in other fields may also be considered to be within the purview of the present invention.

BACKGROUND

Dwindling natural resources, dangerous contamination levels, increasing prices and unreliable dependence on other countries are making it increasingly necessary to search an alternative to fossil fuels like oil (hydrocarbons) and oil derivatives as the primary energy source in automobiles. To date, none of the attempted alternatives appears to have proved its worth as a substitute for petrol, either because of inherent drawbacks as to contamination, safety, cost, etc. or because man has not yet been able to find a practical way of applying the alternative energy forms to domestic motor cars.

For instance, electricity is a good alternative in the ecological sense, both chemically and acoustically, however it appears to be the least efficient form of energy known, which together with the high cost of manufacture of electric motors and the severe storage limitations insofar capacity and size have stopped it from coming into the market at least for the time being. The same is generally true even when solar energy is concerned.

Nuclear power is efficient, available and relatively cheap, but extremely perilous. Synthetic fuels may certainly be the answer in the future, however it appears that none practical enough have been developed. Use of gases such as methane or propane, or of alcohol distilled from sugar cane, has also been tried, but for one reason or another its marketing has been limited to small regions. Methanol for instance is a promising synthetic fuel, but it is extremely difficult to ignite in cold weather and has a low energy content (about half that of petrol).

The use of hydrogen gas as a substitute for petrol has been experimented lately. The chemistry investigator Derek P. Gregory is cited as believing that hydrogen is the ideal fuel in not just one sense. Hydrogen combustion produces steam as its only residue, a decisive advantage over contaminating conventional fuels such as petrol and coal. Unfortunately, hydrogen hardly exists on earth in its natural free form but only combined in chemical

compounds, from which it must be extracted using complicated, expensive and often hazardous industrial processes. In addition, if this obstacle were overcome, it would still be necessary to transport and store the hydrogen in service stations and moreover find a safe and practical way of loading and storing it in motor vehicles. Mercedes-Benz for one is experimenting with a vehicle equipped with a special tank for storing hydrogen gas and means for supplying the gas to the injection system, instead of the conventional petrol tank and circuit, without however yet achieving a satisfactory degree of safety and cost-efficiency. The use of dry hydrogen gas as a propellant has heretofore been found to produce a generally uncontrolled ignition, a large temperature excursion upwards which proved too destructive for the chamber walls. The engine life was limited to less than 10,000 km (about 6,000 miles).

DISCLOSURE OF THE INVENTION

The invention is based on the discovery of an energy-converter system to run an internal combustion engine and particularly is based on the discovery of a method and means for reliably, economically, safely and cleanly fuel an internal combustion engine with hydrogen, and obtaining the hydrogen in a usable form to this end from a cheap and plentifully available substance such as water. The hydrogen may be generated in optimum conditions to be fed into the engine.

According to the invention, hydrogen is obtained on board from a readily available hydrogenous source such as ionised water which is subjected to electrolysis, from whence the hydrogen is injected in each cylinder of the engine on the admission stroke. The hydrogen gas is mixed with water vapour (steam at atmospheric temperature) and surrounding air, and when this mixture is ignited within the combustion chamber, the steam (vapour) seems to act as a temperature moderator first and then assist in the expansion stroke. Preferably, the steam is dry saturated steam which, as a moderator, limits the maximum temperature of the combustion, thus helping to preserve the cylinder, valve and piston elements; and in assisting the expansion, the steam expands fast to contribute extra pressure on the piston head, increasing the mechanical output power of the engine. In other words, the inclusion of steam in the hydrogen propellant as suggested by the present invention moderates the negative effects of hydrogen and enhances the positive effects thereof in the combustion cycle.

As a result of this discovery, the amount of hydrogen required to drive the engine is lower than was heretofore expected, hence the electrolysis need not produce more than 10 cc/sec (for example, for a 1,400 cc engine). Thus the amount of electricity required for the electrolysis, a stumbling block in earlier attempts, is lower, so much so, that on-board hydrogen production is now feasible.

The invention includes an apparatus comprising a first system for generating hydrogen and a second system for conditioning and supplying the hydrogen to the admission valves on the cylinder caps. The hydrogen-generating system basically consists of an electrolysis device which receives electrolytically adapted (i.e. at least partially ionised) water or some other suitable hydrogenous substance. An electric power supply is connected to the electrodes of the electrolysis device for generating the hydrogen, and the electricity requirements and the device dimensions are designed for a maximum hydrogen output rate of about 10 cc/sec for a typical automotive application.

The second system comprises means such as a vacuum pump or the like to draw out the hydrogen from the first system, means for supplying the hydrogen gas to the admission valves, means for conditioning the moisture content of the hydrogen, carburettor means or the like for mixing the hydrogen with atmospheric air or some other combustion enabling substance, and means to control and maintain a specified gas pressure valve or range for the hydrogen supplied to the mixing means.

The apparatus was tested and worked surprisingly well. It was discovered that this seemed to be the result of the steam content in the electrolytic hydrogen gas overcoming the pitfalls encountered in the prior art systems which injected relatively dry gas into the cylinder chambers, or at the most with a relatively small proportion of humidity coming from the air itself.

In the preferred embodiment, the electrolysis system is driven with a pulsed DC power signal of up to 80 Amps at between 75 and 100 Volts. The electrolyte is distilled water salted with sodium chloride with a concentration of about 30 grams of salt per litre of water, to 150 grams of salt in 10 litres of water. Other concentrations are possible depending on the kind of engine, fuel and electricity consumption etc. The maximum rate of hydrogen production required for a typical domestic car engine has been estimated at 10 cc/sec. This hydrogen is drawn out by a pump generating a pressure head of around 2 Kg/cm² to feed the generated steam-containing hydrogen to a receptacle provided with means for removing the undesired excess of moisture from the gas. The gas is thus mixed with the desired content of steam when it enters the carburettor or mixing device.

In the event that the generated hydrogen does not have enough steam content, dry saturated steam may be added to the hydrogen as it proceeds to the engine. This may be done conveniently, before it enters the carburettor

and is mixed with the intake air. Part of the gas may be shunted via a heat-exchanger serpentine connected to the exhaust manifold. This heats some of the gas before it is injected into the base of the carburettor. This heated gas injection operates like a supercharger. The main unheated hydrogen stream is piped directly into the venturi system of the carburettor, where it mixes with air drawn in by the admission stroke vacuum.

BRIEF DESCRIPTION OF THE DRAWINGS

Fig.1 is a schematic layout of the first and second systems and shows the electrolysis device for obtaining hydrogen, and the circuit means for injecting the steam-laden hydrogen into the combustion chambers of a car engine, according to one embodiment of this invention.

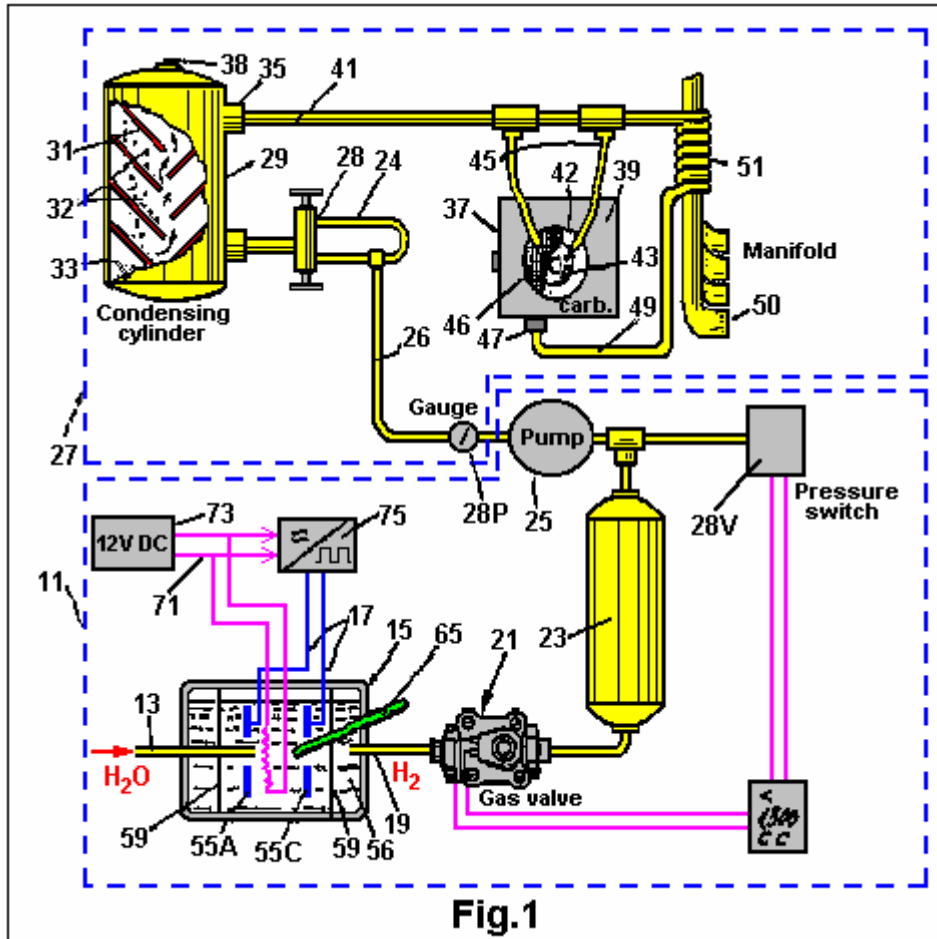
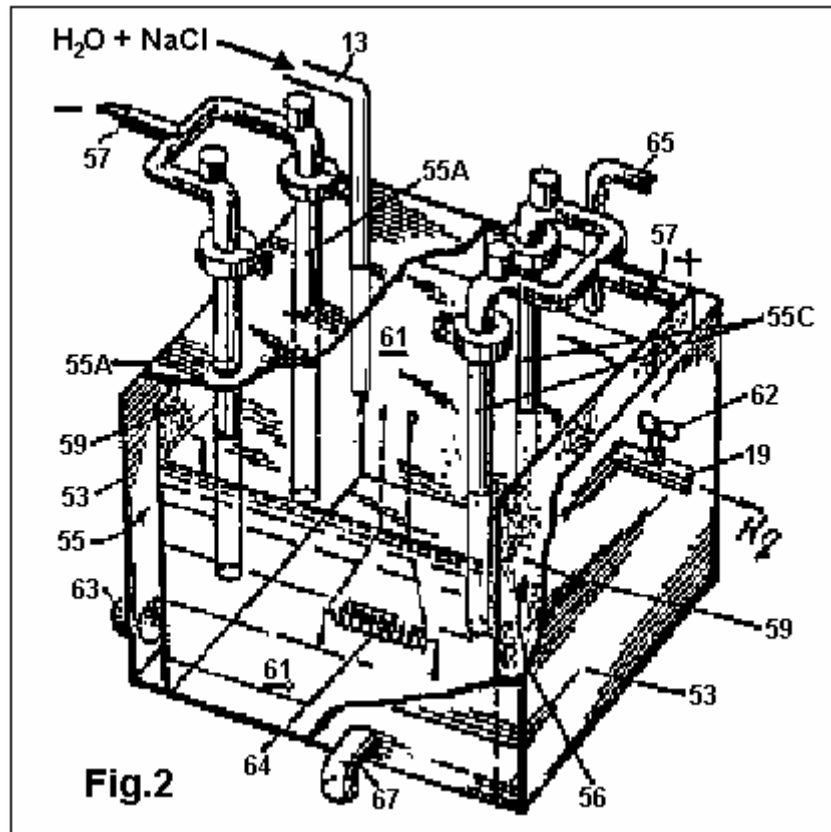

Figure 2 is an elevational view of the electrolysis device of figure 1.



DETAILED ACCOUNT OF AN EMBODIMENT

Fig.1 shows a system **11** for obtaining hydrogen from water piped from a reservoir or tank (not illustrated) to an inlet **13** of an electrolysis cell **15**. The water is salted by adding sodium chloride to ionise it and enable electrolysis when electric power is applied to a pair of terminals **17**. As disclosed in more detail later, the power applied to the terminals **17** is in the form of a DC pulse signal of 65 Amps at 87 Volts, generated via a suitable converter from, in the event that the present system is applied to an automobile, the standard automotive 12 Volt DC level. The device **15** has various outlets, one of which is the hydrogen gas outlet **19** which is connected through a solenoid valve **21** to an accumulator or reservoir cylinder **23**. Other outlets of the electrolysis device **15** are for removing electrolysis effluents such as sodium hydroxide and chlorine gas, to which further reference is made below.

A vacuum pump **25** or similar, extracts gas from the reservoir **23** and channels it through a hydrogen circuit system **27**. Thus the reservoir **23** acts as a pressure buffer of a systems interface between the electrolysis device **15** and the pump **25**. The reservoir **23** may be a 2,000 cc capacity, stainless-steel cylinder with the valve **21** metering the passage of gas through it, so that the reservoir is initially filled with about 1,500 cc of hydrogen at normal pressure and temperature (NPT) conditions. To this end, the cylinder **23** may be provided with a gauge **28V** which controls the state of valve **21** electronically. Valve **21** may be a Jefferson Model SPS solenoid valve, available from OTASI, Santa Rosa 556, Córdoba, Argentina. Vacuum pump **25** is a diaphragm pump with a pulley drive and it is coupled by means of a transmission belt to the engine's crankshaft output. Such a device **25** may be a Bosch model available in Germany. The pulley drive is decoupled by an electromagnetic clutch when the pressure read by a gauge **28P** screwed into the outlet side of pump **25** exceeds 2Kg/sq. cm.

Pump **25** sends hydrogen through tubing **26**, which also includes a by-pass **24** provided for inspection and safety purposes together with a two-way valve **28**, and into a second cylinder **29** which contains means **31** which cause a turbulence or a labyrinthine movement in the gas, in order to condense the heavy mixture, schematically shown as droplets **32**, present in the gas stream. The condensed mixture collects in the form of distilled water **33** at the bottom of cylinder **29**. Near the top of the cylinder, there is an outlet **35** through which hydrogen gas, laden with a good amount of steam, is transported to mixer **37**. Also at the top of collector cylinder **29**, there is a temperature sensor **38** which is connected to an electronic digital thermometer circuit (not shown).

Mixer **37** comprises a carburettor device **39** for mixing hydrogen with air prior to feeding the mixture to the

combustion chambers. The hydrogen is piped through a 3/8" diameter tube **41** from dryer cylinder **29** and then into the venturi section **43** of the carburettor **39** through a pair of 5/16" diameter tubes or hydrogen injecting nozzles **45**. The venturi section **43** is a section of the intake air passage which narrows to increase the air speed at the point where hydrogen is drawn out for mixing. The venturi intake **42** may be covered by a mesh **46**. However, it appears that no air filter is needed for the mixer to operate well. The carburettor device **39** may be a simplified form of a conventional carburettor, since the propellant, i.e. hydrogen gas, is fed directly to the venturi **43**. A butterfly valve, or the like, connected to an accelerator pedal (not illustrated) of the motor-car, controls the air intake rate and therefore the speed of the engine. This mixer device **39** is mounted as is a conventional carburettor, such that its outlet at the bottom communicates with the admission valves in the cylinder caps.

At the bottom part of the carburettor there is a supplementary hydrogen intake **47** connected to another 3/8" diameter pipe **49** which shunts part of the hydrogen through a heater **51**. This heater comprises a serpentine tube **51** of a chromium/cobalt alloy, mounted in close heat-exchange relationship with the body of the exhaust manifold **50** (schematically illustrated) in order to add a portion of heated gas to the fuel mixture before it is drawn into the combustion chambers through the corresponding admission valves on the cylinder caps. This pre-admission heating step, takes the hydrogen mixture to a near critical temperature for detonation. It has been found that this improves performance (e.g. the engine smoothness) at some speed ranges, and it works like a supercharger.

In practice, the engine of the present invention has shown a high efficiency when using three-electrode sparking plugs and an electronic ignition system (not illustrated).

Fig.2 shows the electrolysis cell **15** outlined in **Fig.1** in more detail. It is comprised of a rectangular prism reservoir **53** with a pair of spaced-apart vertical electrodes **55**. The reservoir may measure, for instance, 24 cm long by 20 cm wide and 28 cm high. Both the anode and cathode **55** may each comprise double electrodes of carbon having a spacing between the electrodes **55** of the same polarity of about 10 cm. Alternatively, the anode **55A** may be a ring made of carbon while the cathode **55C** is an iron-mesh cylindrical electrode. Each electrode **55** has a terminal **57** at the top for inputting electric power as mentioned earlier. At each outer side of the electrodes **55** there is a porous membrane **59** made from a sheet of amianto (asbestos) for holding the water solution **61** in whilst at the same time letting the electrolysis products, i.e. hydrogen and oxygen, pass through. Thus, the hydrogen gas passes through the membrane **59** into a gas collector chamber **56** and exits out through pipe **19** to fuel the combustion engine. The hydrogen pipe **19** may have a proportioning valve **62** for regulating the flow of hydrogen. The oxygen on the other hand may be vented out into the atmosphere through an outlet **63**.

There is a heater element **64**, immersed in the salted water **61** fed through a resistor connected to a 12 Volt DC supply. This heats the water to about 85 degrees C (185 degrees F) to enhance the galvanic action of the electrolysis current on the aqueous solution **61**. A thermostat with a solid state silicon thermal sensor may be used to control the water temperature via a threshold comparator driving a relay which controls the current in the heater element **64**.

The electrolysis of the heated salted water solution **61** further produces, as effluents, chlorine gas (Cl_2) and sodium hydroxide (NaOH). The chlorine gas may be vented through an opening **65** at the top of the reservoir **53** or else stored in an appropriate disposal tank (not shown). The sodium hydroxide precipitates and may be removed periodically through tap **67** at the bottom of the electrolysis cell.

It is important to note that the practice of the present invention requires practically no modifications in the engine itself. That is, existing petrol engines may be used with hardly any adjustments. Ignition is initiated at the dead top of the compression stroke or with a 1.5 degree lag at the most, and it has been found convenient to widen the gaps of the admission and exhaust valve pushers and use tri-electrode spark plugs. However it is advisable to use some rust-resistant compound such as plastics for the exhaust pipe and silencer, bearing in mind that the combustion residue is hot steam.

Fig.1 also shows schematically, the electric power supply **71** connected to the terminals **17** of the cube **15**. Electrical current is obtained at 12 volt DC from the car battery/alternator system **73** and processed by an inverter device **75** for generating DC pulses of 65 Amps at 87 Volts. Pulse energisation of the electrolysis appears to maximise the ratio of hydrogen output rate to electric power input.

CLAIMS

1. A method of providing propellant to an internal combustion engine wherein combustion is fuelled on the basis of hydrogen gas admitted into at least one combustion chamber of the engine during the intake stroke, characterised in that the hydrogen is injected into the combustion chamber together with vapour.
2. The method of claim 1, characterised in that the surrounding air enters the combustion chamber, together with the hydrogen and vapour.

3. The method of claim 2, characterised in that the hydrogen gas is obtained from water which is continuously subjected to electrolysis energised by the engine.
4. The method of claim 2 or 3, characterised in that the hydrogen is generated at a rate of not more than 10 cc/sec.
5. The method of any of the preceding claims, characterised in that the engine drives a motor-car.
6. The method of any of preceding claims, characterised in that the vapour is added to the hydrogen prior to entering the combustion chamber.
7. The method of any of claims 1 to 5, characterised in that the vapour is contained in the hydrogen when generated.
8. The method of any of the preceding claims, characterised in that the vapour is dry saturated steam.
9. A method of driving a internal combustion engine with water as its primary source of energy, characterised by the steps of subjecting the water to hydrolysis thereby producing gaseous hydrogen, and controllably supplying the hydrogen produced by the hydrolysis to the engine combustion chambers during the admission stroke of each cylinder together with a proportion of steam.
10. The method of claim 9, characterised in that the steam is dry saturated steam.
11. The method of any of claims 9 or 10, characterised in that the hydrolysis driven by electric power to produce not more than 10 cc/sec of the hydrogen gas.
12. The method of any of claims 9 to 11, characterised in that the engine drives a motor-car including a water tank as its main propellant supply.
13. The method of any of claims 9 to 12, characterised in that at least part of the hydrogen is heated before injecting it into the chamber.
14. The method of any claims of 9 to 13, characterised in that steam is obtained together with the hydrogen gas from the electrolysis and then subjected to a drying cycle up to a predetermined point of saturation before being passed into the chambers.
15. The method of claim 11, characterised in that the hydrolysis means is supplied with about 5 kW pulsed electrical power.
16. A method of injecting propellant into an hydrogen-driven internal combustion engine cylinder during the admission stroke thereof, characterised in that dry steam is passed into said cylinder during the intake stroke to moderate temperature generation of the hydrogen ignition and enhance expansion after ignition has begun to increase the power of the pistons.
17. A method of obtaining hydrogen capable of being used to fuel an internal combustion engine, characterised by dissociating hydrogen gas from a hydrogenous compound, and admitting the hydrogen gas into each cylinder of said engine together with an amount of dry steam.
18. The method of claim 17, characterised in that the hydrogen gas is admitted to the engine cylinders at a rate of not more than 10 cc/sec.
19. The method of claim 17 or 18, characterised in that the compound is slightly salted water and the steam is saturated steam.
20. A system for obtaining and providing hydrogen propellant to an internal combustion engine including at least one cylinder containing a piston which is subjected to successive combustion cycles and injection means for admitting fuel into the cylinder on the intake or admission stroke of the cycle, characterised by comprising: fuel source means for containing a hydrogenous compound, electrolysis means (15) having at least one pair of electrodes (55) for receiving electric power and intake means (13) connected to the source for supplying the compound to the electrolysis means, a means (27, 37) for extracting hydrogen gas from one of the electrodes and supplying it to the cylinder injection means, and control means (25, 28, 29) for controlling the supply of hydrogen gas to the cylinder injection means whereby the rate of gas consumption in the engine is not more than 10 cc/sec.

21. The system of claim 20, characterised in that the means supplying hydrogen gas to the cylinder injection means further include means **(37)** for mixing said hydrogen gas with steam.
22. The system of claim 20 or 21, characterised in that the compound is water and the source means includes a water tank, the water including salt to facilitate electrolysis.
23. The system of claim 20, 21 or 22, characterised in that the control means include means **(29)** for removing the excessive moisture from the hydrogen gas extracted from the hydrolysis means.
24. The system of any of claims 20 to 23, characterised in that the electrolysis means is energised by the engine.
25. An internal combustion engine operating on hydrogen and having a water tank as its primary source of combustion fuel, a cylinder block containing at least one cylinder chamber, each chamber, having an associated piston, fuel intake means, ignition means, and exhaust means, and crankshaft means coupled to be driven by the pistons for providing mechanical output power from the engine, and characterised by further comprising: electrolysis means **(15)** connected to the water tank for electrolysing water to obtain hydrogen, electrical means **(17)** connected to supply electric power to at least one pair of electrodes **(55)** of the electrolysis means for carrying out the electrolysis of the water, and hydrogen circuit means **(27)** for extracting the hydrogen gas from the electrolysis means and passing it onto said intake means in a manner enabling controlled ignition and expansion of the fuel in the chamber.
26. The engine of claim 25, characterised in that said hydrogen circuit means passes hydrogen gas to the intake means at a rate of not more than 10 cc/sec.
27. The engine of claim 25 or 26, characterised by further comprising means for adding steam into each chamber before ignition of the hydrogen.
28. The engine of claim 27, characterised in that the steam adder means comprises means **(25)** for extracting steam from the electrolysis means, and means **(29)** for subjecting said steam to a drying process up to a pre-determined point.
29. The engine of any of claims 25 to 28, characterised by further comprising means **(49, 51)** for heating at least part of the hydrogen gas before it is passed into the chambers.
30. The engine of claim 29, characterised in that said heating means is a serpentine **(51)** inserted in a shunt **(49)** of the hydrogen circuit means and mounted in heat-exchange relationship on a manifold exhaust of the engine.
31. The engine of any of claims 25 to 30, characterised in that said electrical means include pulse generator means for supplying electrical pulses to said at least one pair of electrodes.
32. The engine of claim 31, characterised in that said pulse generator means supplies electrical DC pulses of between 50 and 75 Amps at between 60 and 100 Volts.
33. The engine of any of claims 25 to 32, characterised in that said hydrogen circuit means includes drying means **(33)** for removing excess moisture from the hydrogen extracted from the electrolysis means.
34. The engine of any of claims 25 to 33, characterised in that said crankshaft means drives a water-fuelled automobile.
35. The engine of any of claims 25 to 34, characterised in that the electrolysis means is driven by electricity derived from the engine.

The HHO Fuel System of Stephen Horvath

US Patent 3,980,053

14th September 1976

Inventor: Stephen Horvath

FUEL SUPPLY APPARATUS FOR INTERNAL COMBUSTION ENGINES

Please note that this is a re-worded excerpt from this patent. It describes the water-splitting procedure of Stephen Horvath.

ABSTRACT

A fuel supply apparatus generates hydrogen and oxygen by electrolysis of water. There is provided an electrolytic cell which has a circular anode surrounded by a cathode with a porous membrane between them. The anode is fluted and the cathode is slotted to provide anode and cathode areas of substantially equal surface area. A pulsed electrical current is provided between the anode and cathode for the efficient generation of hydrogen and oxygen.

The electrolytic cell is equipped with a float, which detects the level of electrolyte within the cell, and water is added to the cell as needed to replace the water lost through the electrolysis process. The hydrogen and oxygen are collected in chambers which are an integral part of the electrolytic cell, and these two gases are supplied to a mixing chamber where they are mixed in the ratio of two parts hydrogen to one part oxygen. This mixture of hydrogen and oxygen flows to another mixing chamber wherein it is mixed with air from the atmosphere.

The system is disclosed as being installed in an car, and a dual control system, which is actuated by the car throttle, first meters the hydrogen and oxygen mixture into the chamber wherein it is combined with air and then meters the combined mixture into the car engine. The heat of combustion of a pure hydrogen and oxygen mixture is greater than that of a gasoline and air mixture of comparable volume, and air is therefore mixed with the hydrogen and oxygen to produce a composite mixture which has a heat of combustion approximating that of a normal gas-air mixture. This composite mixture of air, hydrogen and oxygen then can be supplied directly to a conventional internal combustion engine without overheating and without creation of a vacuum in the system.

BACKGROUND OF THE INVENTION

This invention relates to internal combustion engines. More particularly it is concerned with a fuel supply apparatus by means of which an internal combustion engine can be run on a fuel comprised of hydrogen and oxygen gases generated on demand by electrolysis of water.

In electrolysis a potential difference is applied between an anode and a cathode in contact with an electrolytic conductor to produce an electric current through the electrolytic conductor. Many molten salts and hydroxides are electrolytic conductors but usually the conductor is a solution of a substance which dissociates in the solution to form ions. The term "electrolyte" will be used herein to refer to a substance which dissociates into ions, at least to some extent, when dissolved in a suitable solvent. The resulting solution will be referred to as an "electrolyte solution".

Faraday's Laws of Electrolysis provide that in any electrolysis process the mass of substance liberated at an anode or cathode is in accordance with the formula

$$m = z q$$

where m is the mass of substance liberated in grams, z is the electrochemical equivalent of the substance, and q is the quantity of electricity passed, in coulombs. An important consequence of Faraday's Laws is that the rate of decomposition of an electrolyte is dependent on current and is independent of voltage. For example, in a conventional electrolysis process in which a constant current I amps flows for t seconds, $q = It$ and the mass of material deposited or dissolved will depend on I regardless of voltage, provided that the voltage exceeds the minimum necessary for the electrolysis to proceed. For most electrolytes, the minimum voltage is very low.

There have been previous proposals to run internal combustion engines on a fuel comprised of hydrogen gas. Examples of such proposals are disclosed in U.S. Pat. Nos. 1,275,481, 2,183,674 and 3,471,274 and British specifications Nos., 353,570 and 364,179. It has further been proposed to derive the hydrogen from electrolysis of water, as exemplified by U.S. Pat. No. 1,380,183. However, none of the prior art constructions is capable of producing hydrogen at a rate such that it can be fed directly to internal combustion engines without intermediate

storage. The present invention enables a fuel comprised of hydrogen and oxygen gases to be generated by electrolysis of water at such a rate that it can sustain operation of an internal combustion engine. It achieves this result by use of an improved electrolysis process of the type generally proposed in the parent application hereof.

As disclosed in my aforesaid parent application the prior art also shows electrolytic reactions employing DC or rectified AC which necessarily will have a ripple component; an example of the former being shown for instance in Kilgus U.S. Pat. No. 2,016,442 and an example of the latter being shown in Emich al. U.S. Pat. No. 3,485,742. It will be noted that the Kilgus Patent also discloses the application of a magnetic field to his electrolyte, which field is said to increase the production of gas at the two electrodes.

SUMMARY OF THE INVENTION

The apparatus of the invention applies a pulsating current to an electrolytic solution of an electrolyte in water. Specifically, it enables high pulses of quite high current value and appropriately low voltage to be generated in the electrolyte solution by a direct input supply to produce a yield of electrolysis products such that these products may be fed directly to the internal combustion engine. The pulsating current generated by the apparatus of the present invention is to be distinguished from normal variations which occur in rectification of AC current and as hereinafter employed the term pulsed current will be taken to mean current having a duty cycle of less than 0.5.

It is a specific object of this invention to provide a fuel supply apparatus for an internal combustion engine by which hydrogen and oxygen gases generated by electrolysis of water are mixed together and fed directly to the internal combustion engine.

A still further object of the invention is to provide, for use with an internal combustion engine having inlet means to receive a combustible fuel, fuel supply apparatus comprising:

a vessel to hold an electrolyte solution of electrolyte dissolved in water;

an anode and a cathode to contact the electrolyte solution within the vessel;

electrical supply means to apply between said diode and said cathode pulses of electrical energy to induce a pulsating current in the electrolyte solution thereby to generate by electrolysis hydrogen gas at the cathode and oxygen gas at the anode;

gas collection and delivery means to collect the hydrogen and oxygen gases and to direct them to the engine inlet means; and

water admission means for admission of water to said vessel to make up loss due to electrolysis.

In order that the invention may be more fully explained one particular example of an car internal combustion engine fitted with fuel supply apparatus in accordance with the invention will now be described in detail with reference to the accompanying drawings.

BRIEF DESCRIPTION OF THE DRAWINGS

Fig.1 is a plan view of part of the car with its engine bay exposed to show the layout of the fuel supply apparatus and the manner in which it is connected to the car engine;

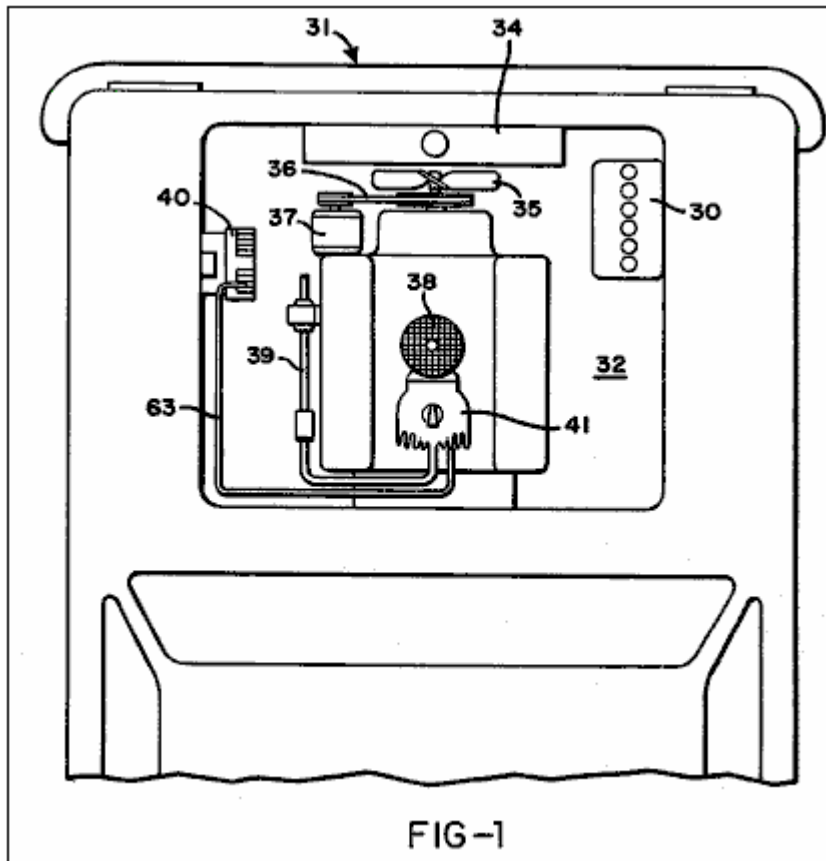

Fig.2 is a circuit diagram of the fuel supply apparatus;

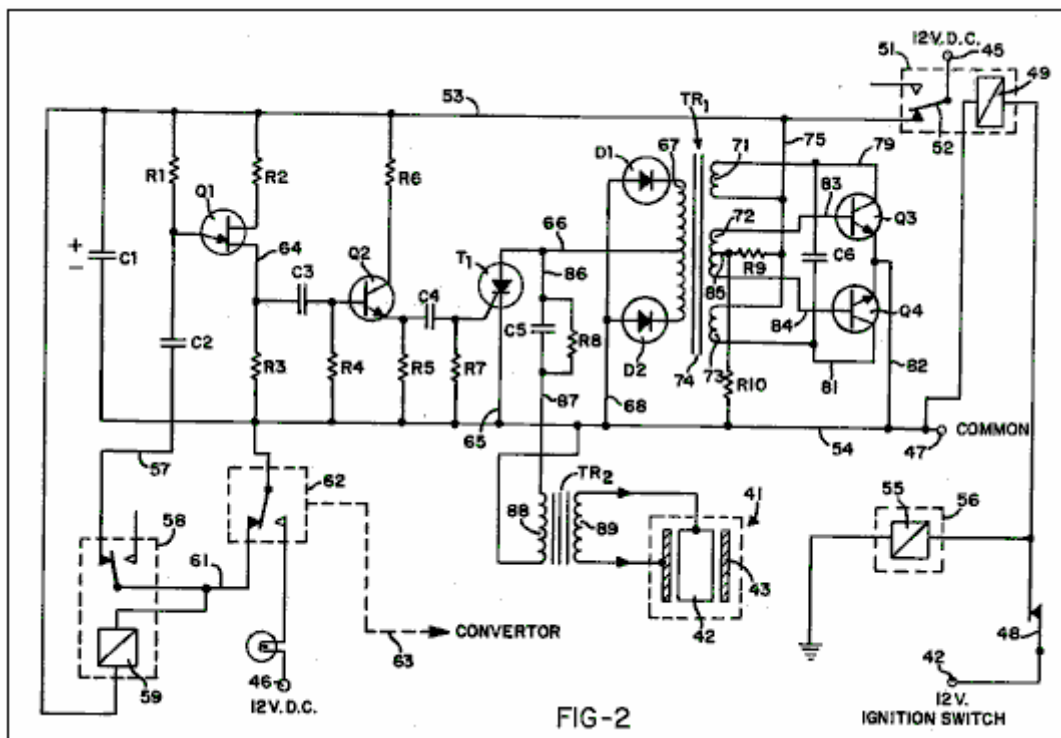

Fig.3 is a plan view of a housing which carries electrical components of the fuel supply apparatus;

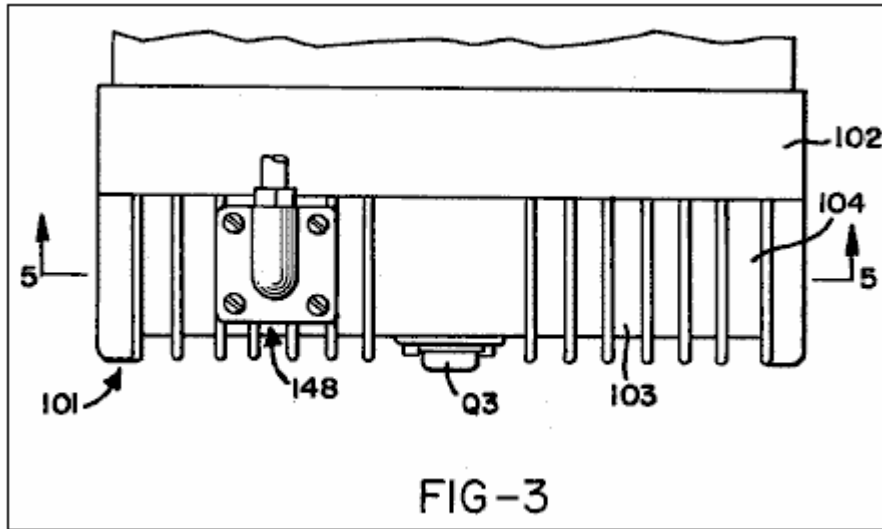

Fig.4 is an elevation view of the housing shown in Fig.3;

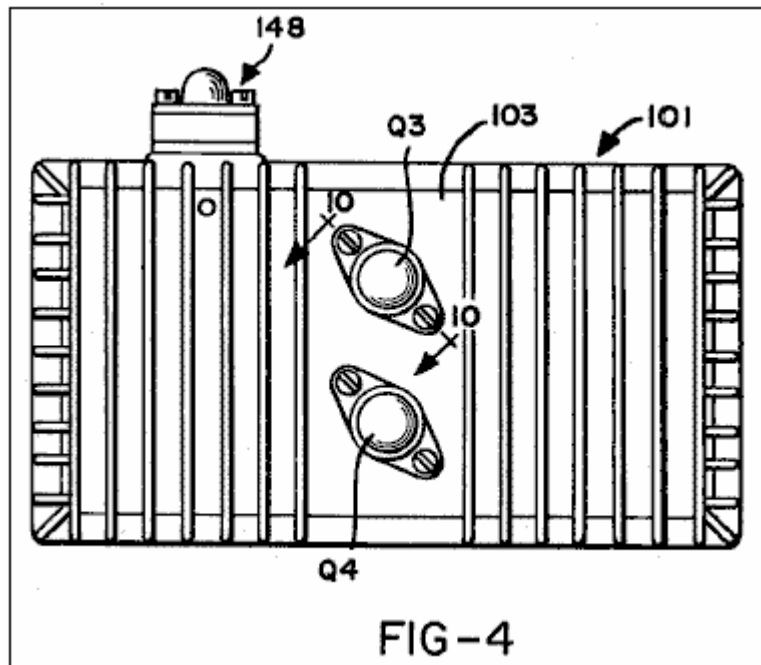

Fig.5 is a cross-section on the line 5--5 in Fig.3;

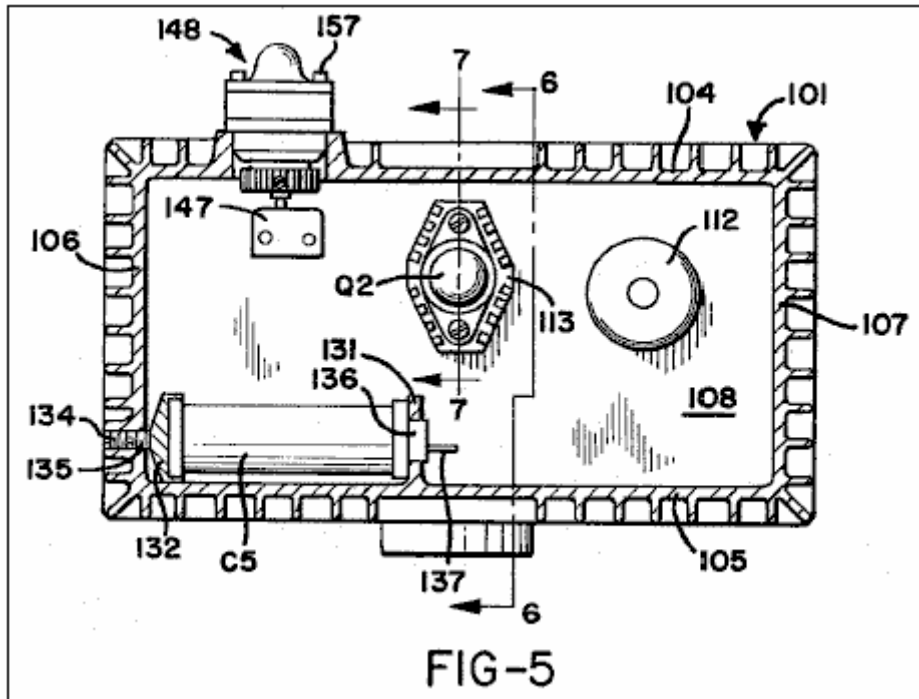

Fig.6 is a cross-section on the line 6--6 in Fig.3;

Fig.7 is a cross-section on the line 7--7 in Fig.5;

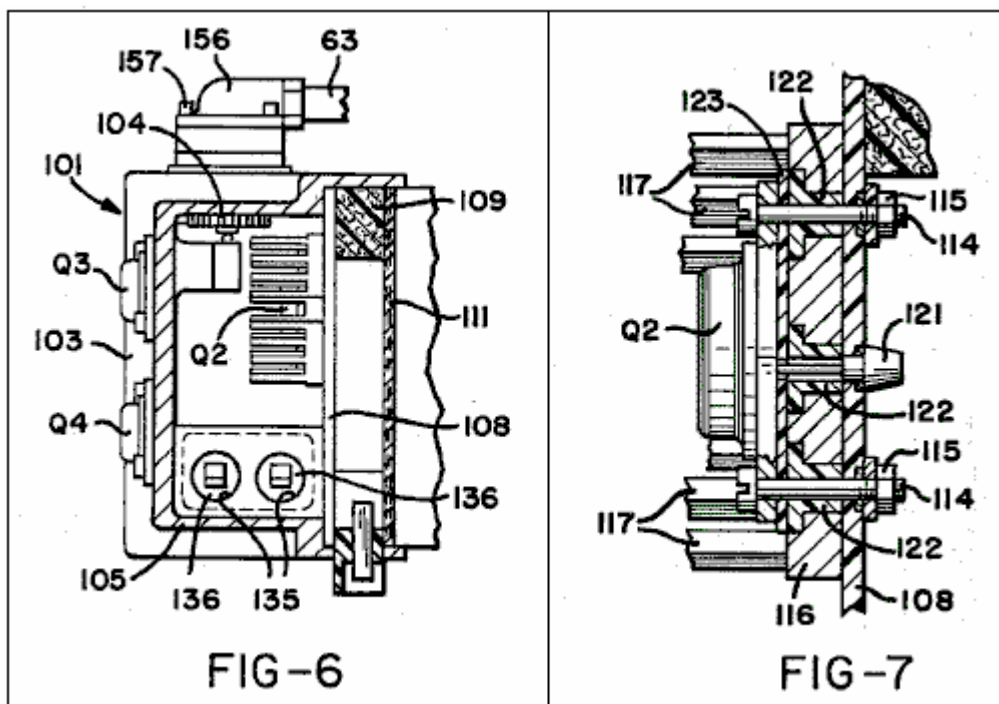

Fig.8 is a perspective view of a diode heat sink included in the components illustrated in Fig.5 and Fig.7;

Fig.9 illustrates a transformer coil assembly included in the electrical components mounted within the housing;

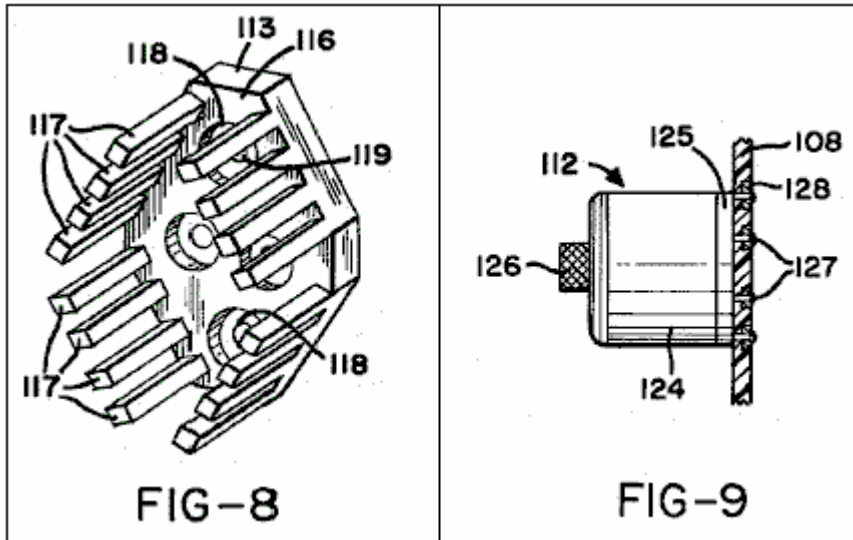

Fig.10 is a cross-section on the line 10--10 in Fig.4;

Fig.11 is a cross-section on the line 11--11 in Fig.5;

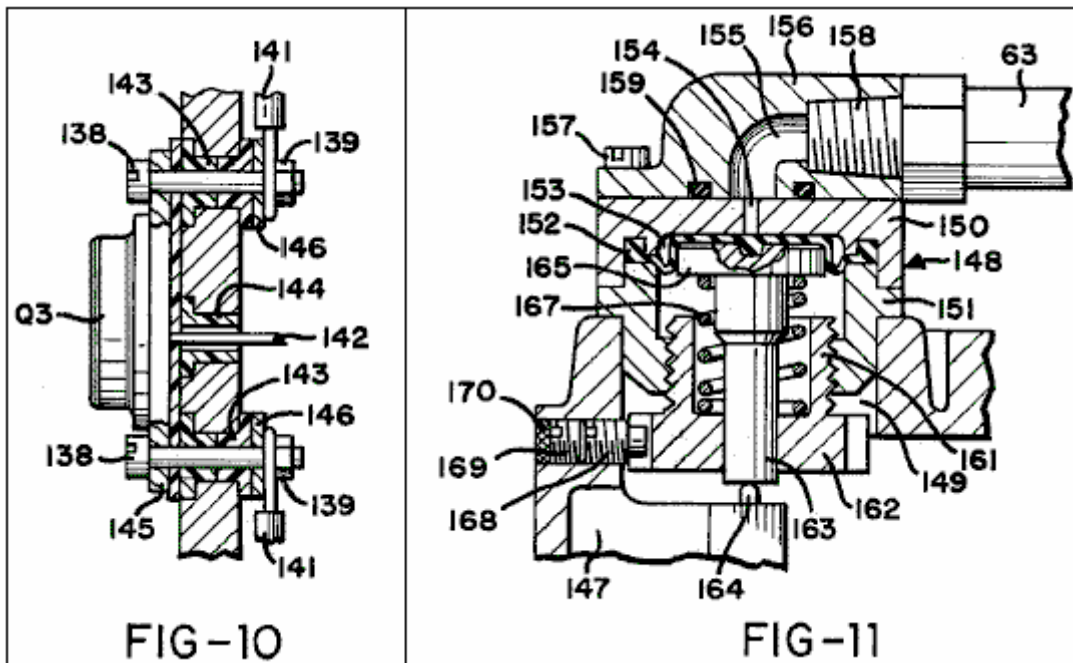

Fig.12 is a cross-section through a terminal block mounted in the floor of the housing;

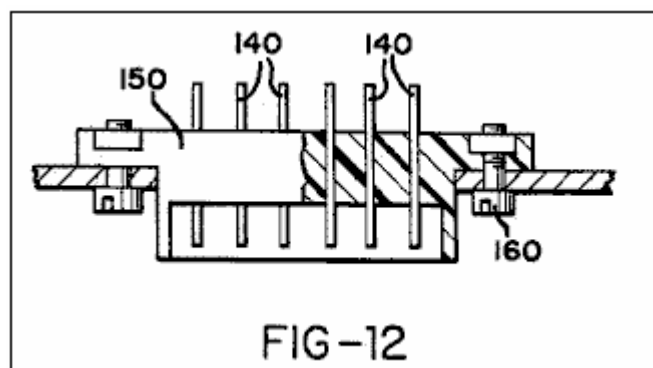

Fig.13 is a plan view of an electrolytic cell incorporated in the fuel supply apparatus;

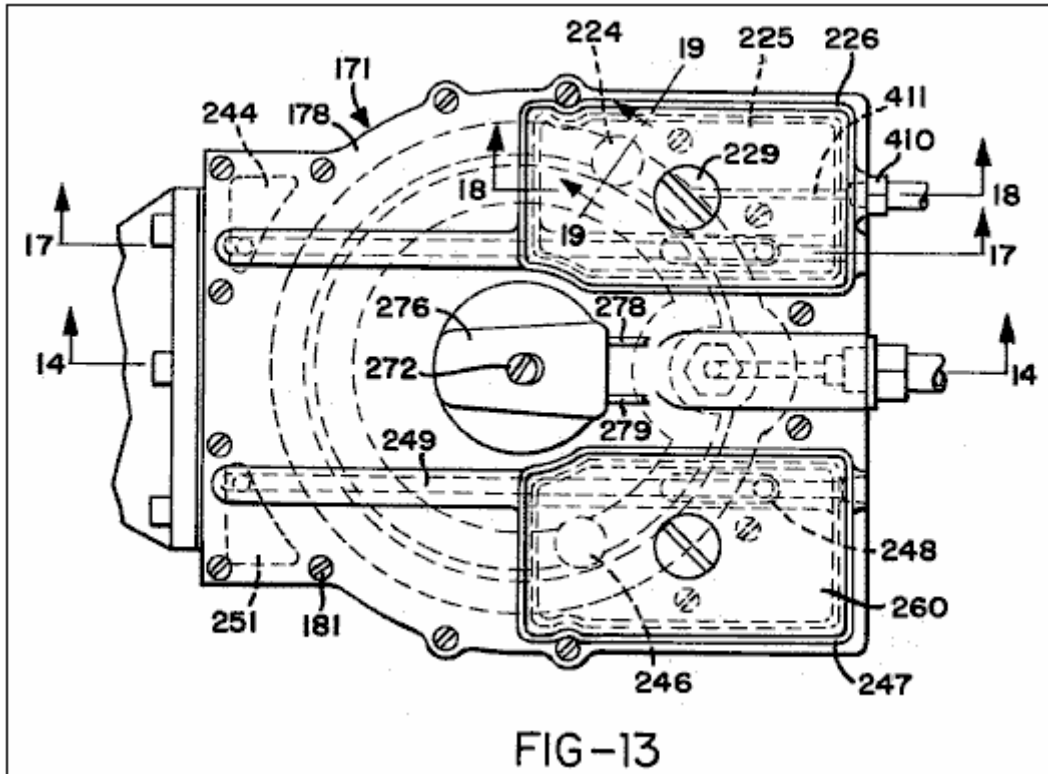

Fig.14 is a cross-section on the line 14--14 in Fig.13;

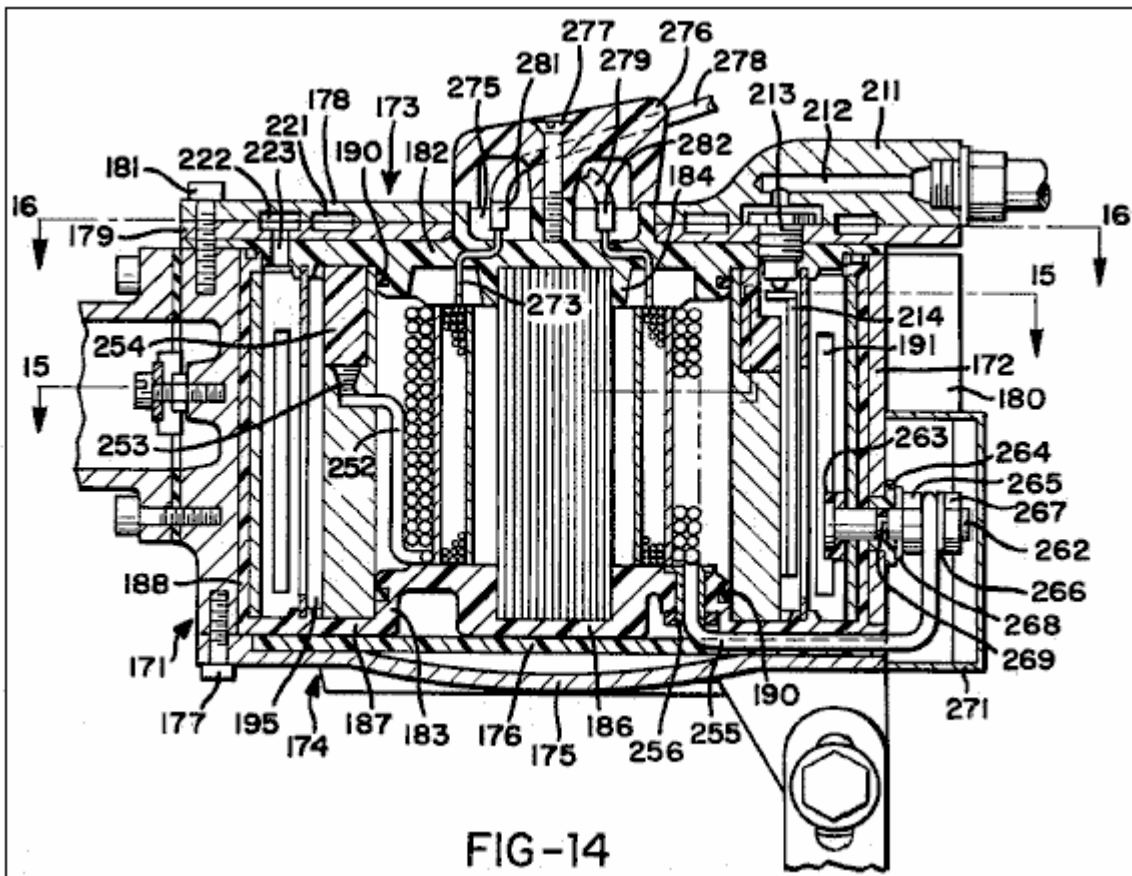

Fig.15 is a cross-section generally on the line 15--15 in Fig.14;

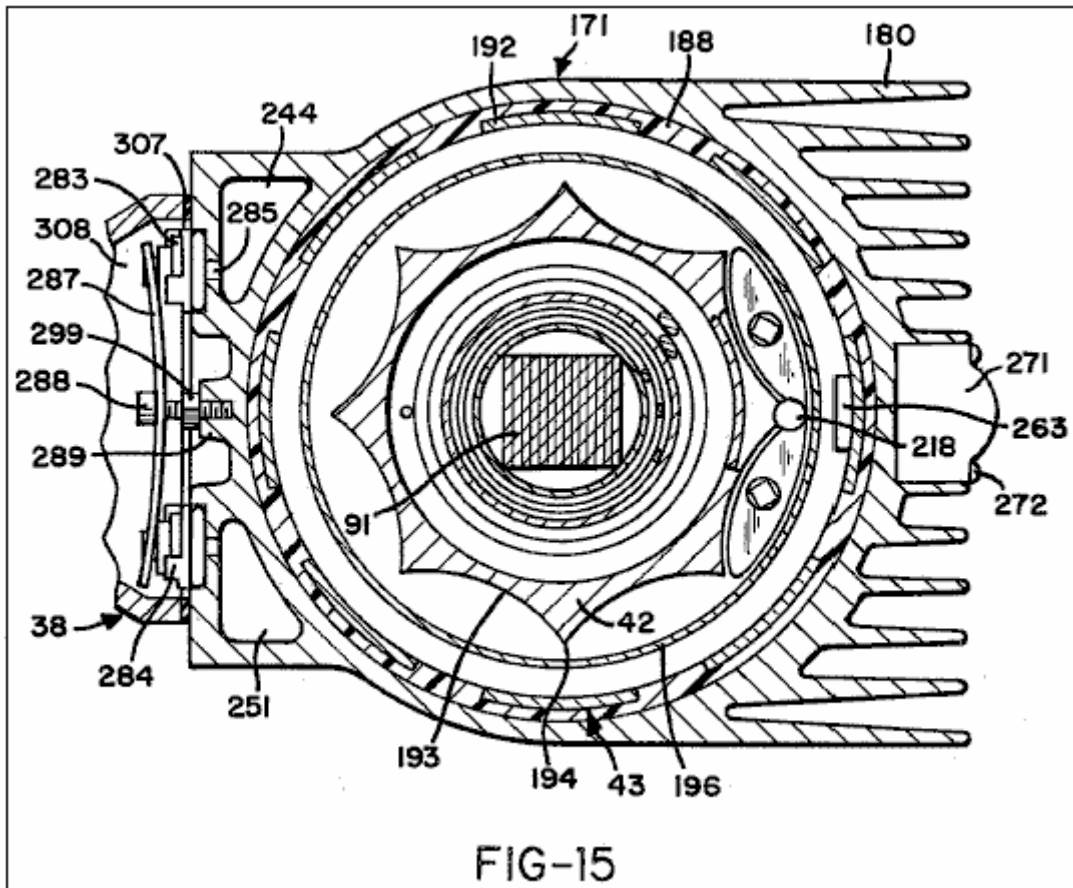

Fig.16 is a cross-section on the line 16--16 in Fig.14;

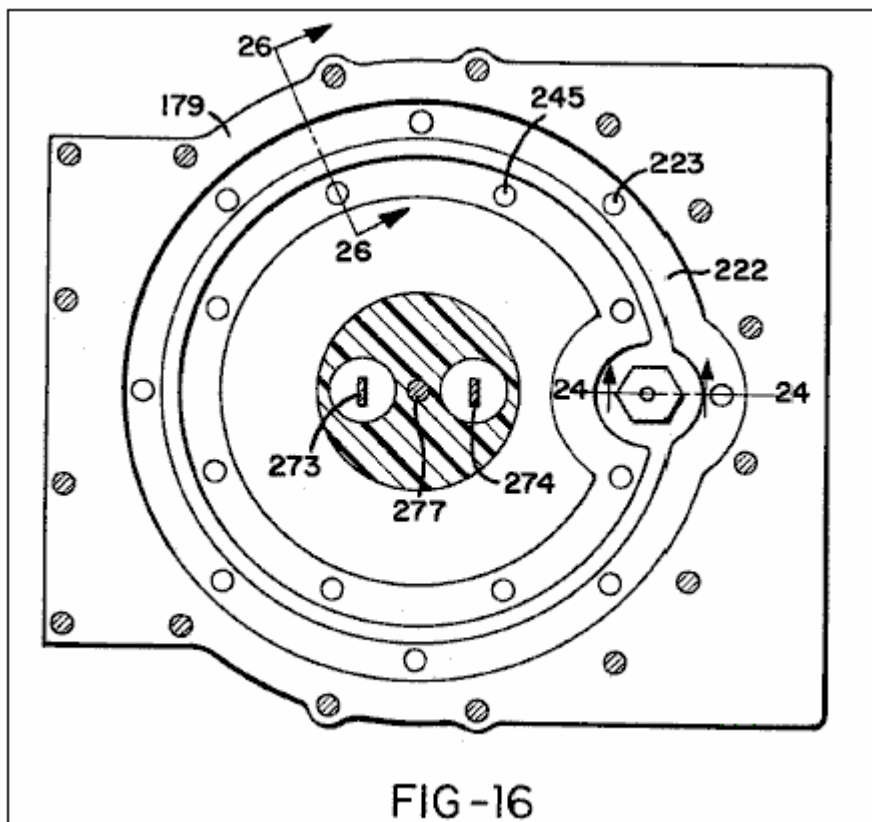

Fig.17 is a cross-section on the line 17--17 in Fig.13;

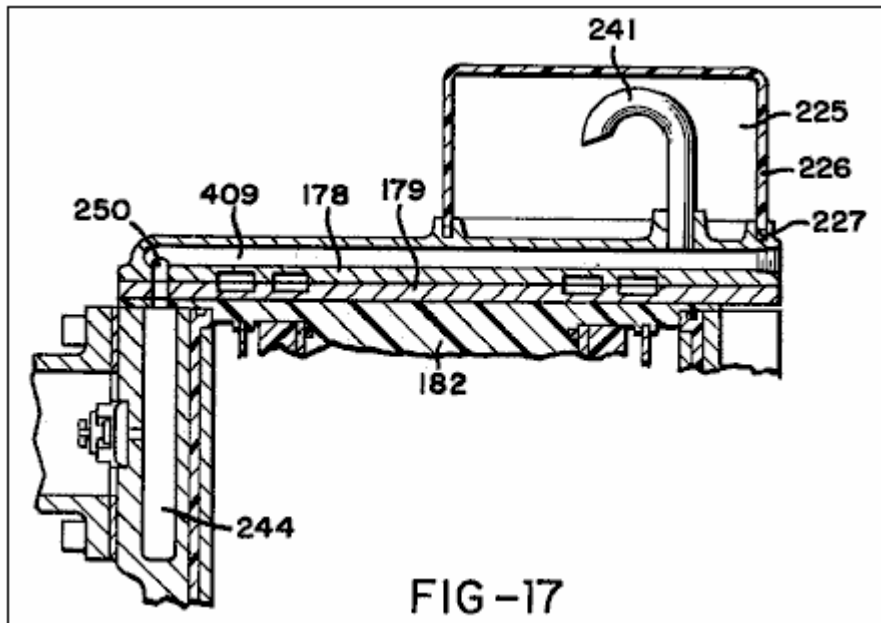

Fig.18 is a cross-section on the line 18--18 of Fig.13;

Fig.19 is a vertical cross-section through a gas valve taken generally on line 19--19 in Fig.13;

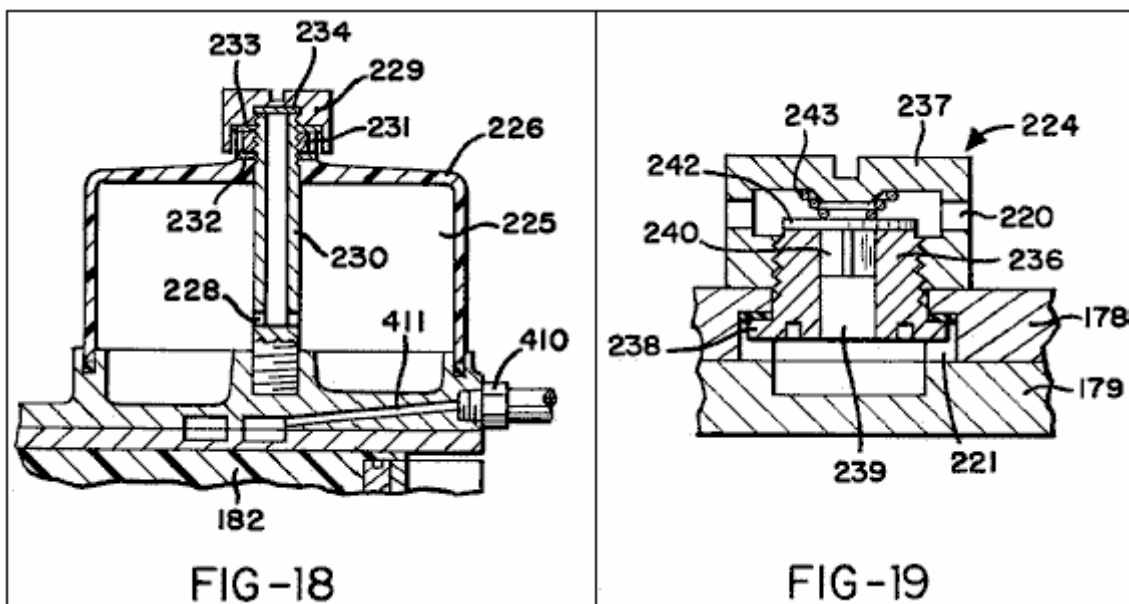

Fig.20 is a perspective view of a membrane assembly disposed in the electrolytic cell;

Fig.21 is a cross-section through part of the membrane assembly;

Fig.22 is a perspective view of a float disposed in the electrolytic cell;

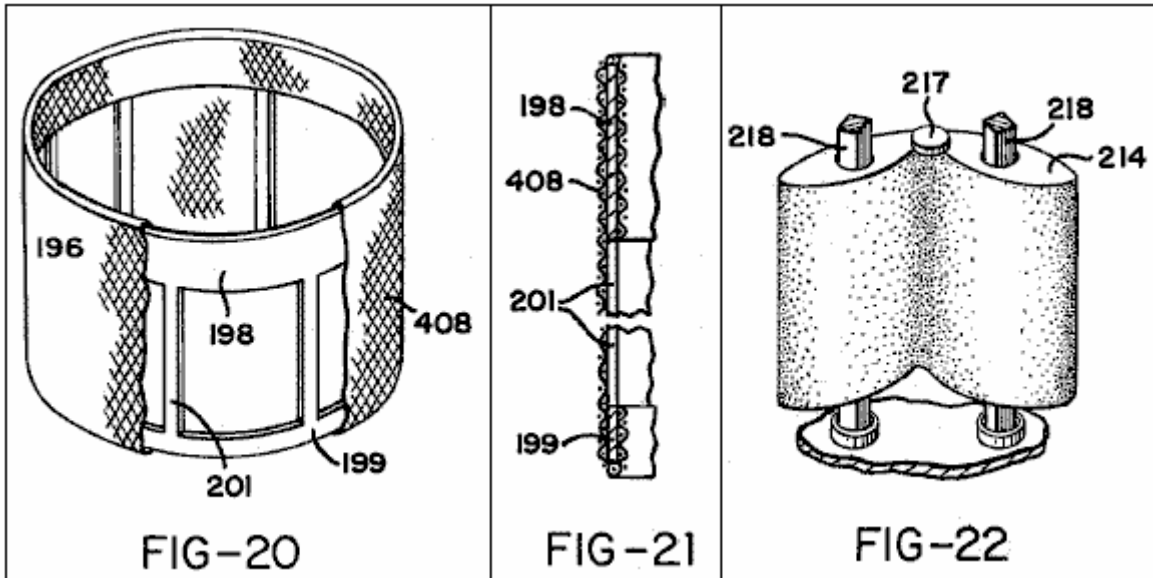

Fig.23 is an enlargement of part of Fig.14;

Fig.24 is an enlarged cross-section on the line 24--24 in Fig.16;

Fig.25 is a perspective view of a water inlet valve member included in the components shown in Fig.24;

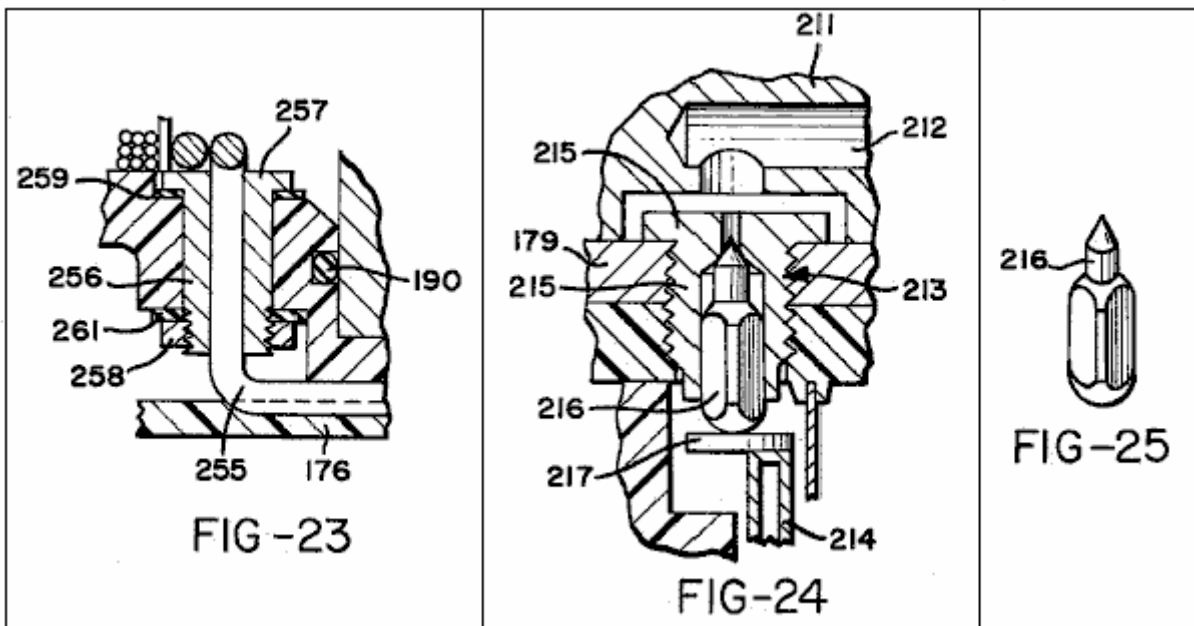

Fig.26 is a cross-section on line 26--26 in Fig.16;

Fig.27 is an exploded and partly broken view of a cathode and cathode collar fitted to the upper end of the cathode;

Fig.28 is an enlarged cross-section showing some of the components of Fig.15;

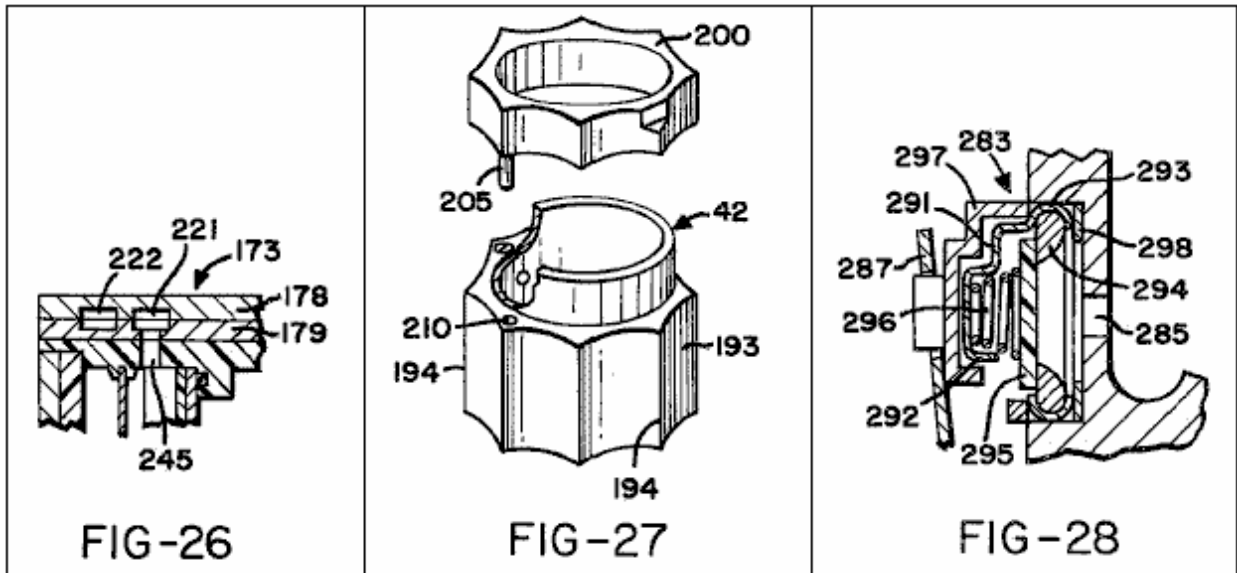

Fig.29 is a perspective view of a valve cover member;

Fig.30 shows a gas mixing and delivery unit of the apparatus generally in side elevation but with an air filter assembly included in the unit shown in section;

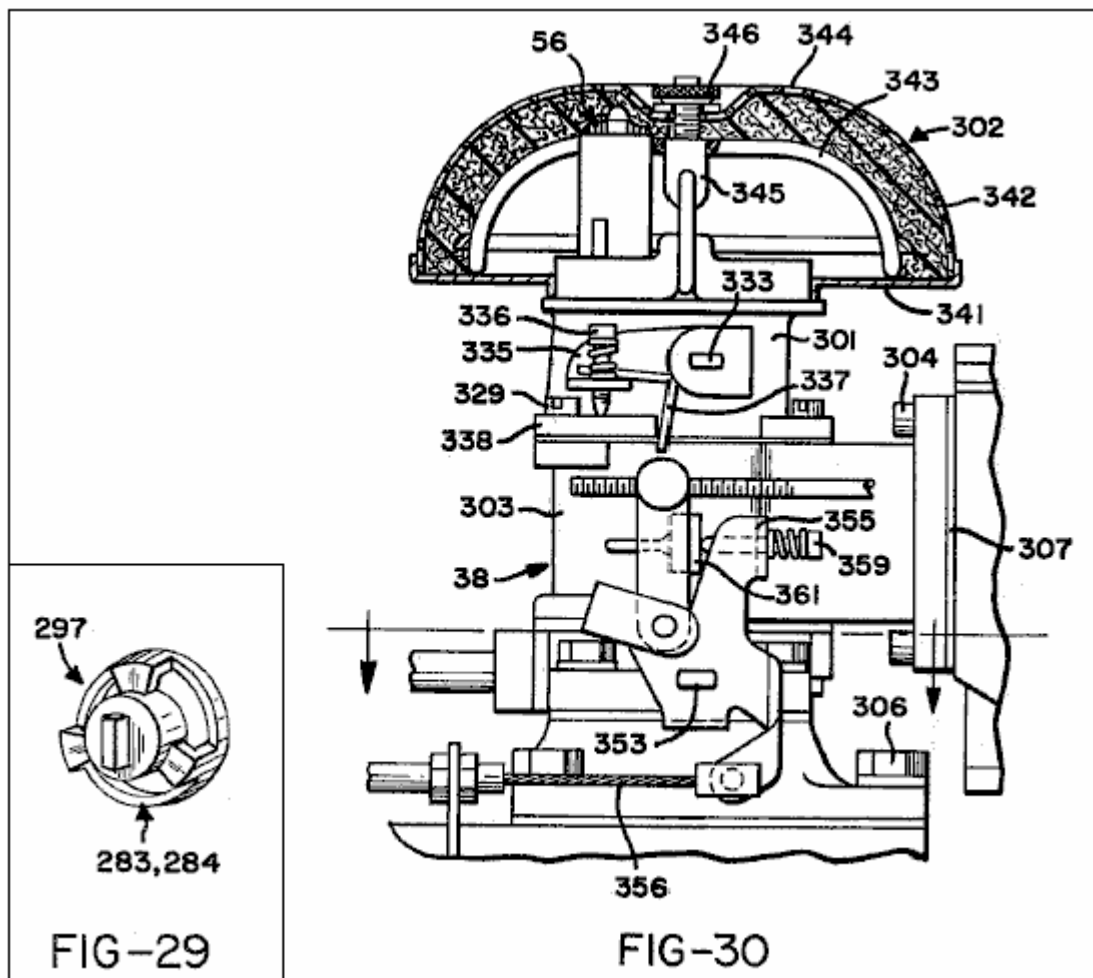

Fig.31 is a vertical cross-section through the gas mixing and delivery unit with the air filter assembly removed;

Fig.32 is a cross-section on the line 32--32 in Fig.31;

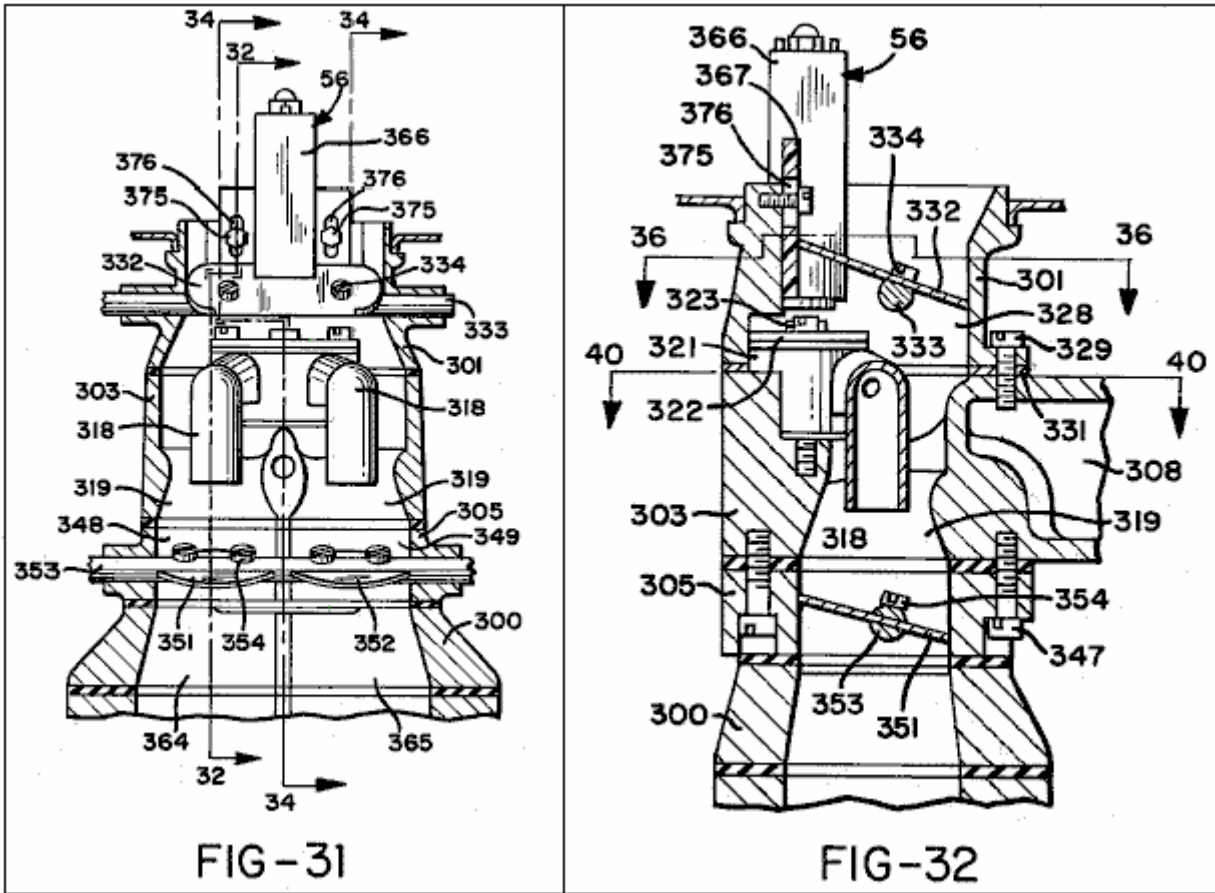

Fig.33 is a perspective view of a valve and jet nozzle assembly incorporated in the gas mixing and delivery unit;

Fig.34 is a cross-section generally on the line 34--34 in Fig.31;

Fig.35 is a cross-section through a solenoid assembly;

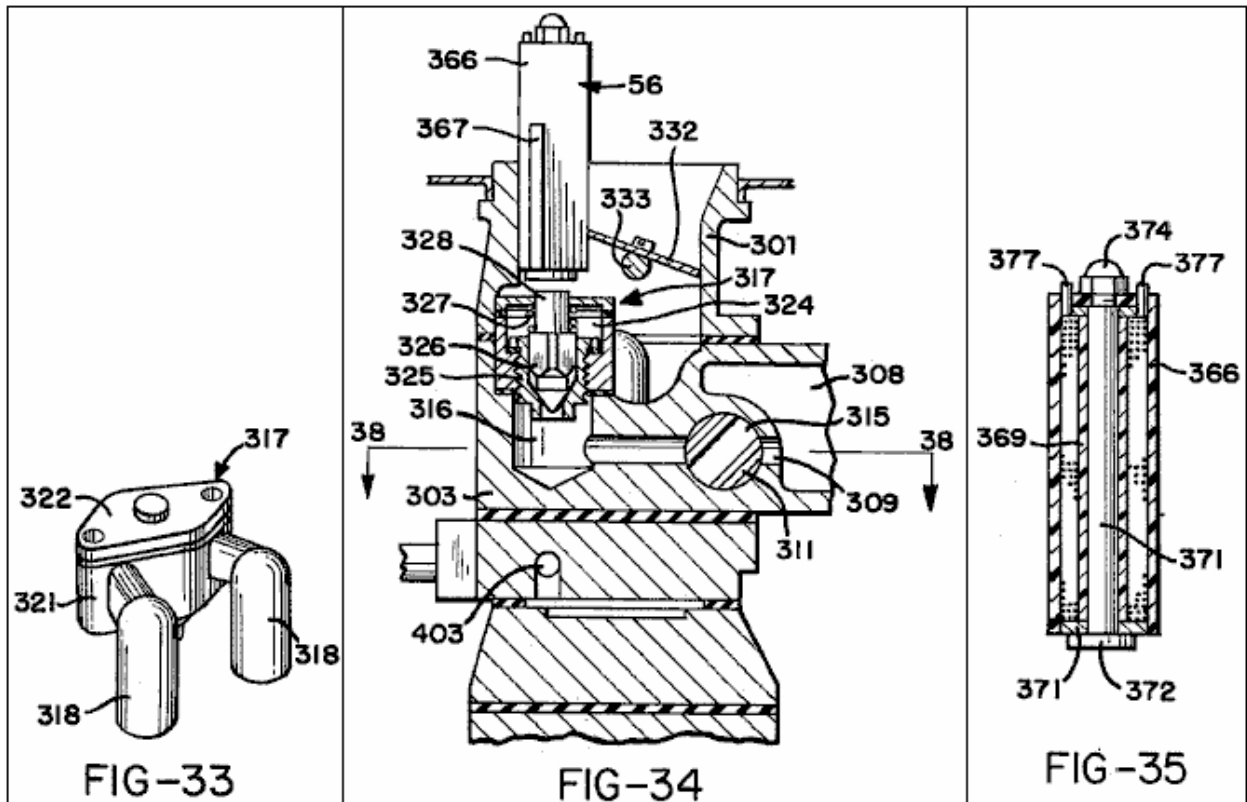

Fig.36 is a cross-section on the line 36--36 in Fig.32;

Fig.37 is a rear elevation of part of the gas mixing and delivery unit;

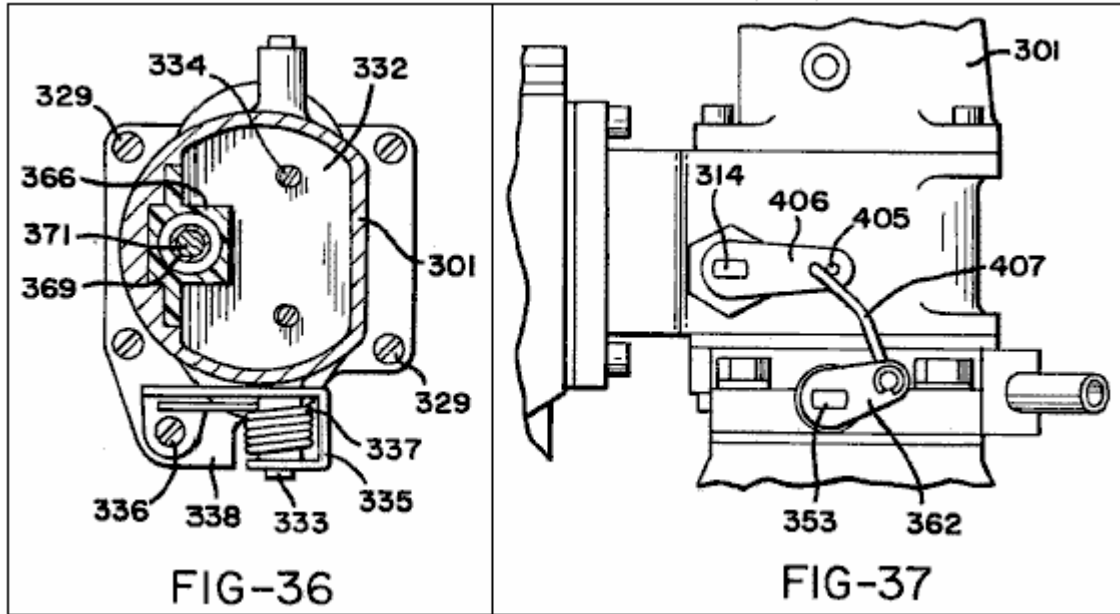

Fig.38 is a cross-section on the line 38--38 in Fig.34;

Fig.39 is a plan view of the lower section of the gas mixing and delivery unit, which is broken away from the upper section along the interface 39--39 of Fig.30;

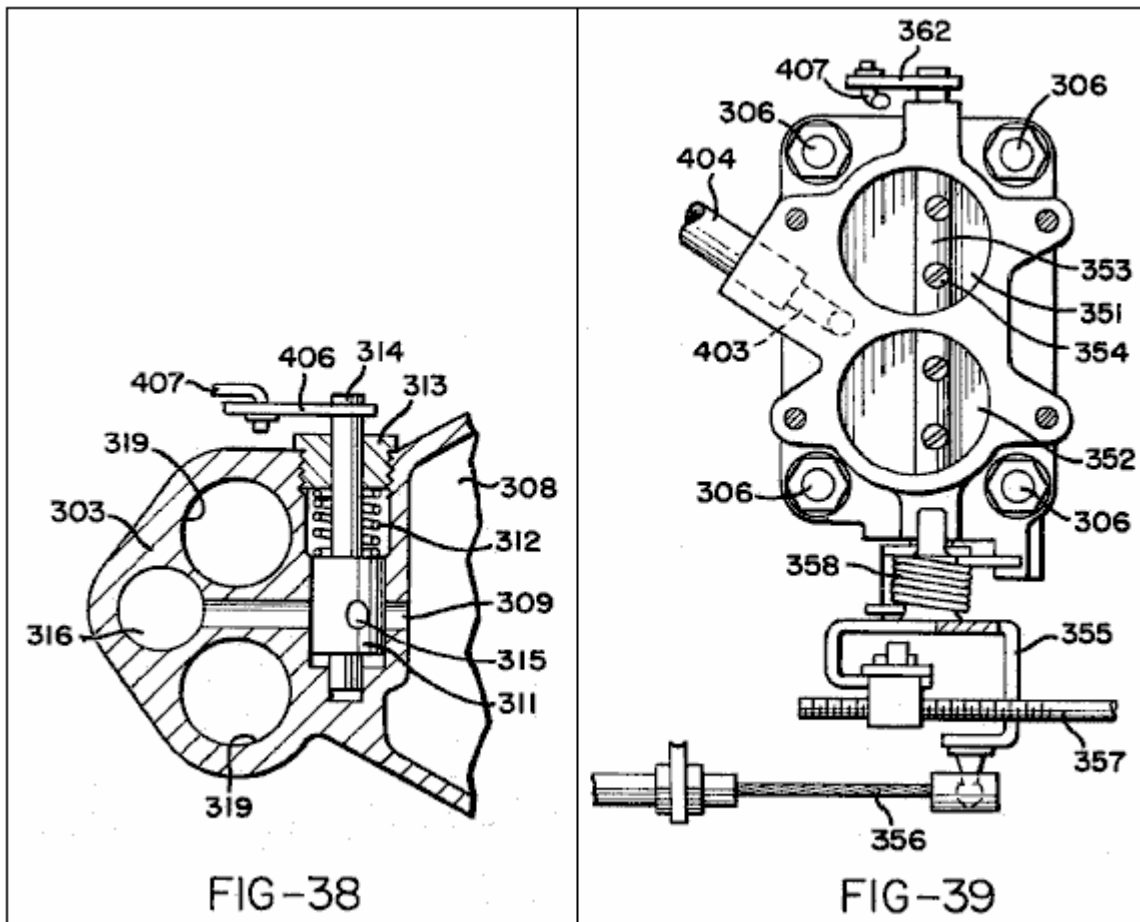
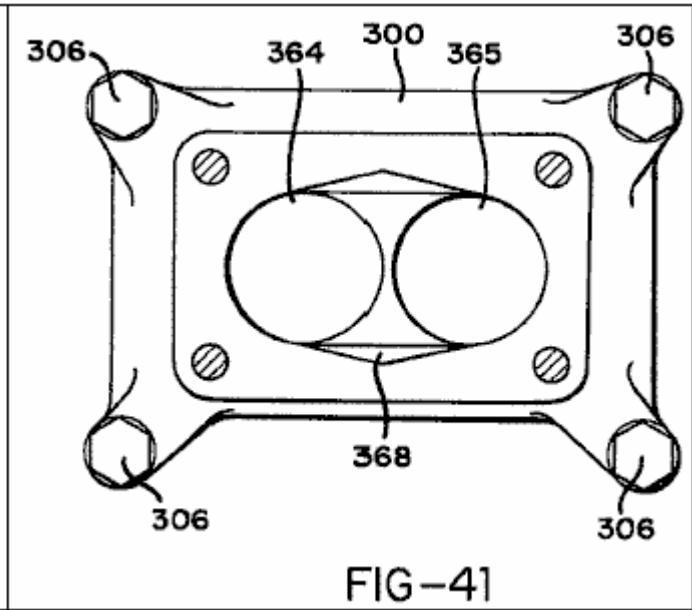
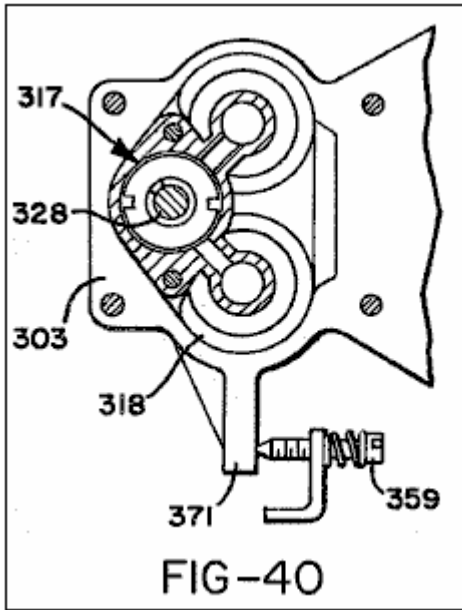

Fig.40 is a cross-section on the line 40--40 in Fig.32; and

Fig.41 is a plan of a lower body part of the gas mixing and delivery unit.



DESCRIPTION OF THE PREFERRED EMBODIMENT

Fig.1 shows an assembly denoted generally as **31** having an engine bay **32** in which an internal combustion engine **33** is mounted behind a radiator **34**. Engine **33** is a conventional engine and, as illustrated, it may have two banks of cylinders in "V" formation. Specifically, it may be a V8 engine. It is generally of conventional construction and **Fig.1** shows the usual cooling fan **34**, fan belt **36** and generator or alternator **37**.

In accordance with the invention the engine does not run on the usual petroleum fuel but is equipped with fuel supply apparatus which supplies it with a mixture of hydrogen and oxygen gases generated as products of a water electrolysis process carried out in the fuel supply apparatus. The major components of the fuel supply apparatus are an electrolytic cell denoted generally as **41** and a gas mixing and delivery unit **38** to mix the hydrogen and oxygen gases generated within the cell **41** and to deliver them to engine **33**. The electrolytic cell **41** receives water through a water delivery line **39** to make up the electrolyte solution within it. It has an anode and a cathode which contact the electrolyte solution, and in operation of the apparatus pulses of electrical energy are applied between the anode and cathode to produce pulses of high current flow through the electrolyte solution. Some of the electrical components necessary to produce the pulses of electrical energy applied between the anode and cathode are carried in a housing **40** mounted on one side of engine bay **32**. The car battery **30** is mounted at the other side of the engine bay.

Before the physical construction of the fuel delivery apparatus is described in detail the general principles of its operation will firstly be described with reference to the electrical circuit diagram of **Fig.2**.

In the illustrated circuit terminals **44**, **45**, **46** are all connected to the positive terminal of the car battery **30** and terminal **47** is connected to the negative terminal of that battery. Switch **48** is the usual ignition switch of the car and closure of this switch provides current to the coil **49** of a relay **51**. The moving contact **52** of relay **51** receives current at 12 volts from terminal **45**, and when the relay is operated by closure of ignition switch **48** current is supplied through this contact to line **53** so that line **53** may be considered as receiving a positive input and line **54** from terminal **47** may be considered as a common negative for the circuit. Closure of ignition switch **48** also supplies current to one side of the coil **55** of a solenoid **56**. The other side of solenoid coil **55** is earthed by a connection to the car body within the engine bay. As will be explained below solenoid **56** must be energised to open a valve which controls supply of hydrogen and oxygen gases to the engine and the valve closes to cut off that supply as soon as ignition switch **48** is opened.

The function of relay **51** is to connect circuit line **53** directly to the positive terminal of the car battery so that it receives a positive signal directly rather than through the ignition switch and wiring.

The circuit comprises pulse generator circuitry which includes unijunction transistor **Q1** with associated resistors **R1**, **R2** and **R3** and capacitors **C2** and **C3**. This circuitry produces pulses which are used to trigger an NPN silicon power transistor **Q2** which in turn provides via a capacitor **C4** triggering pulses for a thyristor **T1**.

Resistor **R1** and capacitor **C2** are connected in series in a line **57** extending to one of the fixed contacts of a relay **58**. The coil **59** of relay **58** is connected between line **53** and a line **61** which extends from the moving contact of the relay to the common negative line **54** via a normally closed pressure operated switch **62**. The pressure control line **63** of switch **62** is connected in a manner to be described below to a gas collection chamber of electrolytic cell **41** in order to provide a control connection whereby switch **62** is opened when the gas in the collection chamber reaches a certain pressure. However, provided that switch **62** remains closed, relay **58** will operate when ignition switch **48** is closed to provide a connection between lines **57** and **61** thereby to connect capacitor **C2** to the common negative line **54**. The main purpose of relay **58** is to provide a slight delay in this connection between the capacitor **C2** and the common negative line **54** when the circuit is first energised. This will delay the generation of triggering pulses to thyristor **T1** until a required electrical condition has been achieved in the transformer circuitry to be described below. Relay **58** is hermetically sealed and has a balanced armature so that it can operate in any position and can withstand substantial shock or vibration when the car is in use.

When the connection between capacitor **C2** and line **54** is made via relay **58**, unijunction transistor **Q1** will act as an oscillator to provide positive output pulses in line **64** at a pulse rate which is controlled by the ratio of **R1:C1** and at a pulse strength determined by the ratio of **R2:R3**. These pulses will charge the capacitor **C3**. Electrolytic capacitor **C1** is connected directly between the common positive line **53** and the common negative line **54** to filter the circuitry from all static noise.

Resistor **R1** and capacitor **C2** are chosen such that at the input to transistor **Q1** the pulses will be of saw tooth form. This will control the form of the pulses generated in the subsequent circuitry and the saw tooth pulse form is chosen since it is believed that it produces the most satisfactory operation of the pulsing circuitry. It should be stressed, however, that other pulse forms, such as square wave pulses, could be used. Capacitor **C3** discharges

through a resistor **R4** to provide triggering signals for transistor **Q2**. Resistor **R4** is connected to the common negative line **54** to serve as a gate current limiting device for transistor **Q2**.

The triggering signals produced by transistor **Q2** via the network of capacitor **C3** and a resistor **R4** will be in the form of positive pulses of sharply spiked form. The collector of transistor **Q2** is connected to the positive supply line **53** through resistor **R6** while the emitter of that transistor is connected to the common negative line **54** through resistor **R5**. These resistors **R5** and **R6** control the strength of current pulses applied to a capacitor **C4**, which discharges through a resistor **R7** to the common negative line **54**, thereby to apply triggering signals to the gate of thyristor **T1**. The gate of thyristor **T1** receives a negative bias from the common negative line via resistor **R7** which thus serves to prevent triggering of the thyristor by inrush currents.

The triggering pulses applied to the gate of thyristor **T1** will be very sharp spikes occurring at the same frequency as the saw tooth wave form pulses established by unijunction transistor **Q1**. It is preferred that this frequency be of the order of 10,000 pulses per minute and details of specific circuit components which will achieve this result are listed below. Transistor **Q2** serves as an interface between unijunction transistor **Q1** and thyristor **T1**, preventing back flow of emf from the gate of the thyristor which might otherwise interfere with the operation of transistor **Q1**. Because of the high voltages being handled by the thyristor and the high back emf applied to transistor **Q2**, the latter transistor must be mounted on a heat sink.

The cathode of thyristor **T1** is connected via a line **65** to the common negative line **54** and the anode is connected via a line **66** to the centre of the secondary coil **67** of a first stage transformer **TR1**. The two ends of transformer coil **67** are connected via diodes **D1** and **D2** and a line **68** to the common negative line **54** to provide full wave rectification of the transformer output.

First stage transformer **T1** has three primary coils **71**, **72**, **73** wound together with secondary coil **67** about a core **74**. This transformer may be of conventional half cup construction with a ferrite core. The secondary coil may be wound on to a coil former disposed about the core and primary coils **71** and **73** may be wound in bifilar fashion over the secondary coil. The other primary coil **72** may then be wound over the coils **71**, **73**. Primary coils **71** and **73** are connected at one side by a line **75** to the uniform positive potential of circuit line **53** and at their other sides by lines **79**, **81** to the collectors of transistors **Q3**, **Q4**. The emitters of transistors **Q3**, **Q4** are connected permanently via a line **82** to the common negative line **54**. A capacitor **C6** is connected between lines **79**, **81** to act as a filter preventing any potential difference between the collectors of transistors **Q3**, **Q4**.

The two ends of primary coil **72** are connected by lines **83**, **84** to the bases of transistors **Q3**, **Q4**. This coil is centre tapped by a line **85** connected via resistor **R9** to the positive line **53** and via resistor **R10** to the common negative line **54**.

When power is first applied to the circuit transistors **Q3** and **Q4** will be in their non-conducting states and there will be no current in primary coils **71**, **73**. However, the positive current in line **53** will provide via resistor **R9** a triggering signal applied to the centre tap of coil **72** and this signal operates to trigger alternate high frequency oscillation of transistors **Q3**, **Q4** which will result in rapid alternating pulses in primary coils **71**, **73**. The triggering signal applied to the centre tap of coil **72** is controlled by the resistor network provided by resistors **R9** and **R10** such that its magnitude is not sufficient to enable it to trigger **Q3** and **Q4** simultaneously but is sufficient to trigger one of those transistors. Therefore only one of the transistors is fired by the initial triggering signal to cause a current to flow through the respective primary coil **71** or **73**. The signal required to hold the transistor in the conducting state is much less than that required to trigger it initially, so that when the transistor becomes conductive some of the signal applied to the centre tap of coil **72** will be diverted to the non-conducting transistor to trigger it. When the second transistor is thus fired to become conductive, current will flow through the other of the primary coils **71**, **73**, and since the emitters of the two transistors are directly connected together, the positive output of the second transistor will cause the first-fired transistor to be shut off. When the current drawn by the collector of the second-fired resistor drops, part of the signal on the centre tap of coil **72** is diverted back to the collector of the first transistor which is re-fired. It will be seen that the cycle will then repeat indefinitely so that transistors **Q3**, **Q4** are alternately fired and shut off in very rapid sequence. Thus current pulses flow in alternate sequence through primary coils **71**, **73** at a very high frequency, this frequency being constant and independent of changes in input voltage to the circuit. The rapidly alternating pulses in primary coils **71** and **73**, which will continue for so long as ignition switch **48** remains closed, will generate higher voltage signals at the same frequency in the transformer secondary coil **67**.

A dump capacitor **C5** bridged by a resistor **R8** is connected by a line **86** to the line **66** from the secondary coil of transformer **TR1** and provides the output from that transformer which is fed via line **87** to a second stage transformer **TR2**.

When thyristor **T1** is triggered to become conductive the full charge of dump capacitor **C5** is released to second stage transformer **TR2**. At the same time the first stage of transformer **TR1** ceases to function because of this

momentary short circuit placed across it and consequently thyristor **T1** releases, i.e. becomes non-conductive. This permits charge to be built up again in dump capacitor **C5** for release when the thyristor is next triggered by a signal from transistor **Q2**. Thus during each of the intervals when the thyristor is in its non-conducting state the rapidly alternating pulses in primary coils **71, 73** of transformer **TR1** produced by the continuously oscillating transistors **Q3, Q4** produce, via the transformer coupling, relatively high voltage output pulses which build up a high charge in capacitor **C5**, and this charge is released suddenly when the thyristor is triggered. In a typical apparatus using a 12 volt DC supply battery pulses of the order of 22 amps at 300 volts may be produced in line **87**.

As previously mentioned relay **58** is provided in the circuit to provide a delay in the connection of capacitor **C2** to the common negative line **54**. This delay, although very short, is sufficient to enable transistors **Q3, Q4** to start oscillating to cause transformer **TR1** to build up a charge in dumping capacitor **C5** before the first triggering signal is applied to thyristor **T1** to cause discharge of the capacitor.

Transformer **TR2** is a step-down transformer which produces pulses of very high current flow at low voltage. It is built into the anode of electrolytic cell **41** and comprises a primary coil **88** and a secondary coil **89** wound about a core **91**. Secondary coil **89** is formed of heavy wire in order to handle the large current induced in it and its ends are connected directly to the anode **42** and cathode **43** of the electrolytic cell **41** in a manner to be described below.

In a typical apparatus, the output from the first stage transformer **TR1** would be 300 volt pulses of the order of 22 amps at 10,000 pulses per minute and a duty cycle of slightly less than 0.006. This can be achieved from a uniform 12 volt and 40 amps DC supply using the following circuit components:

Components:

R1 2.7 k ohms 1/2 watt 2% resistor

R2 220 ohms 1/2 watt 2% resistor

R3 100 ohms 1/2 watt 2% resistor

R4 22 k ohms 1/2 watt 2% resistor

R5 100 ohms 1/2 watt 2% resistor

R6 220 ohms 1/2 watt 2% resistor

R7 1 k ohms 1/2 watt 2% resistor

R8 10 m ohms 1 watt 5% resistor

R9 100 ohms 5 watt 10% resistor

R10 5.6 ohms 1 watt 5% resistor

C1 2200 mF 16v electrolytic capacitor

C2 2.2 mF 100v 10% capacitor

C3 2.2 mF 100v 10% capacitor

C4 1 mF 100v 10% capacitor

C5 1 mF 1000v ducon paper capacitor 5S10A

C6 0.002 mF 160v capacitor

Q1 2n 2647 PN unijunction transistor

Q2 2N 3055 NPN silicon power transistor

Q3 2n 3055 NPN silicon power transistor

Q4 2n 3055 NPN silicon power transistor

T1 btw 30-800 rm fast turn-off thyristor

D1 a 14 p diode

D2 a 14 p diode

L1 indicator lamp

Sv1 continuously rated solenoid

R11 pw5ls hermetically sealed relay

Ps1 p658a-10051 pressure operated micro switch

Tr1 half cup transformer cores 36/22-341

Coil former 4322-021-30390 wound to provide a turns ratio between secondary and primary of 18:1

Secondary coil 67 = 380 turns

Primary coil 71 = 9 turns

Primary coil 73 = 9 turns

Primary coil 72 = 4 turns

The installation of the above circuit components is illustrated in **Fig.3** to **Fig.13**. They are mounted within and on a housing which is denoted generally as **101** and which is fastened to a side wall of the car engine bay **32** via a mounting bracket **102**. Housing **101**, which may be formed as an aluminium casting, has a front wall **103**, top and bottom walls **104**, **105** and side walls **106**, **107**. All of these walls have external cooling fins. The back of housing **101** is closed by a printed circuit board **108** which is held clamped in position by a peripheral frame **109** formed of an insulated plastics material clamped between the circuit board and mounting bracket **102**. An insulating sheet **111** of cork is held between the frame **109** and mounting bracket **102**.

Printed circuit board **108** carries all of the above-listed circuit components except for capacitor **C5** and transistors **Q3** and **Q4**. **Fig.5** illustrates the position in which transistor **Q2** and the coil assembly **112** of transformer **TR1** are mounted on the printed circuit board. Transistor **Q2** must withstand considerable heat generation and it is therefore mounted on a specially designed heat sink **113** clamped to circuit board **108** by clamping screws **114** and nuts **115**. As most clearly illustrated in **Fig.7** and **Fig.8**, heat sink **113** has a flat base plate portion **116** which is generally diamond shaped and a series of rod like cooling fins **117** project to one side of the base plate around its periphery. It has a pair of countersunk holes **118** of the clamping screws and a similar pair of holes **119** to receive the connector pins **121** which connect transistor **Q2** to the printed circuit board. Holes **118**, **119** are lined with nylon bushes **122** and a Formica sheet **123** is fitted between the transistor and the heat sink so that the sink is electrically insulated from the transistor.

The coil assembly **112** of transformer **TR1** (See Fig.9) is comprised of a casing **124** which contains transformer coils and the associated core and former and is closed by a plastic closing plate **125**. Plate **125** is held in position by a clamping stud **126** and is fitted with electrical connector pins **127** which are simply pushed through holes in circuit board **108** and are soldered to appropriate copper conductor strips **128** on the outer face of the board.

For clarity the other circuit components mounted on printed circuit board **108** are not illustrated in the drawings. These are standard small size components and the manner in which they may be fitted to the circuit board is entirely conventional.

Capacitor **C5** is mounted within casing **101**. More specifically it is clamped in position between a flange **131** which stands up from the floor **105** of the casing and a clamping pad **132** engaged by a clamping screw **133**, which is mounted in a threaded hole in casing side wall **106** and is set in position by a lock screw **134**. Flange **131** has two holes **135** (See Fig.6) in which the terminal bosses **136** of capacitor **C5** are located. The terminal pins **137** projecting from bosses **136** are connected to the terminal board **108** by wires (not shown) and appropriate connector pins which are extended through holes in the circuit board and soldered to the appropriate conductor strips on the other face of that board.

Transistors **Q3** and **Q4** are mounted on the front wall **103** of casing **101** so that the finned casing serves as an extended heat sink for these two transistors. They are mounted on the casing wall and electrically connected to the printed circuit board in identical fashion and this is illustrated by **Fig.10** which shows the mounting of transistor **Q3**. As shown in that figure the transistor is clamped in position by clamping screws **138** and nuts **139** which also serve to provide electrical connections to the appropriate conductors of the printed circuit board via conductor wires **141**. The third connection from the emitter of the transistor to the common negative conductor of the printed circuit is made by conductor **142**. Screws **130** and conductor **142** extend through three holes in the casing front wall **103** and these holes are lined with electrically insulating nylon bushes **143**, **144**. A Formica sheet **145** is sandwiched between casing plate **103** and the transistor which is therefore electrically insulated from the casing. Two washers **146** are placed beneath the ends of conductor wires **141**.

Pressure operated microswitch **52** is mounted on a bracket **147** projecting inwardly from front wall **103** of casing **101** adjacent the top wall **104** of the casing and the pressure sensing unit **148** for this switch is installed in an opening **149** through top wall **104**. As most clearly seen in **Fig.11**, pressure sensing unit **148** is comprised of two generally cylindrical body members **150**, **151** between which a flexible diaphragm **152** is clamped to provide a diaphragm chamber **153**. The gas pressure of sensing tube **63** is applied to chamber **153** via a small diameter passage **154** in body member **150** and a larger passage **155** in a cap member **156**. The cap member and body members are fastened together and clamped to the casing top plate **104** by means of clamping screws **157**. Sensing tube **63** is connected to the passage **155** in cap member **156** by a tapered thread connector **158** and the interface between cap member **156** and body member **150** is sealed by an O-ring **159**.

The lower end of body member **151** of pressure sensing unit **148** has an internally screw threaded opening which receives a screw **161** which at its lower end is formed as an externally toothed adjusting wheel **162**. A switch actuating plunger **163** extends through a central bore in adjusting wheel **162** so that it engages at one end flexible diaphragm **152** and at the other end the actuator member **164** of microswitch **62**. The end of plunger **163** which engages the diaphragm has a flange **165** to serve as a pressure pad and a helical compression spring **167** encircles plunger **163** to act between flange **165** and the adjusting wheel **162** to bias the plunger upwardly against the action of the gas pressure acting on diaphragm **152** in chamber **153**. The pressure at which diaphragm **152**

will force plunger **163** down against the action of spring **167** to cause actuation of switch **62** may be varied by rotating screw **161** and the setting of this screw may be held by a setting screw **168** mounted in a threaded hole in the upper part of casing front wall **103** and projecting inwardly to fit between successive teeth of adjusting wheel **162**. After correct setting of screw **161** is achieved set screw **168** will be locked in position by locking screw **169** which is then sealed by a permanent seal **170** to prevent tampering. Microswitch **62** is also electrically connected to the appropriate conductors of the printed circuit board via wires within the housing and connector pins.

Electrical connections are made between the conductors of printed circuit board **108** and the internal wiring of the circuit via a terminal block **150** (Fig.12) set in an opening of housing floor **105** by screws **160** and fitted with terminal plates **140**.

The physical construction of electrolytic cell **41** and the second stage transformer **TR2** is illustrated in Fig.13 to Fig.29. The cell comprises an outer casing **171** having a tubular peripheral wall **172** and top and bottom closures **173, 174**. Bottom closure **174** is comprised of a domed cover **175** and an electrically insulated disc **176** which are held to the bottom of peripheral wall **172** by circumferentially spaced clamping studs **177**. Top closure **173** is comprised of a pair of top plates **178, 179** disposed face to face and held by circumferentially spaced clamping studs **181** screwed into tapped holes in the upper end of peripheral wall **172**. The peripheral wall of the casing is provided with cooling fins **180**.

The anode **42** of the cell is of generally tubular formation. It is disposed vertically within the outer casing and is clamped between upper and lower insulators **182, 183**. Upper insulator **182** has a central boss portion **184** and an annular peripheral flange **185** portion the outer rim of which is clamped between upper closure plate **179** and the upper end of peripheral wall **172**. Lower insulator **183** has a central boss portion **186**, an annular flange portion **187** surrounding the boss portion and an outer tubular portion **188** standing up from the outer margin of flange portion **187**. Insulators **182, 183** are moulded from an electrically insulating material which is also alkali resistant. Polytetrafluoroethylene is one suitable material.

When held together by the upper and lower closures, insulators **182, 183** form an enclosure within which anode **42** and the second stage transformer **TR2** are disposed. Anode **42** is of generally tubular formation and it is simply clamped between insulators **182, 183** with its cylindrical inner periphery located on the boss portions **184, 186** of those insulators. It forms a transformer chamber which is closed by the boss portions of the two insulators and which is filled with a suitable transformer oil. O-ring seals **190** are fitted between the central bosses of the insulator plates and the anode to prevent loss of oil from the transformer chamber.

The transformer core **91** is formed as a laminated mild steel bar of square section. It extends vertically between the insulator boss portions **184, 186** and its ends are located within recesses in those boss portions. The primary transformer winding **88** is wound on a first tubular former **401** fitted directly onto core **91** whereas the secondary winding **89** is wound on a second tubular former **402** so as to be spaced outwardly from the primary winding within the oil filled transformer chamber.

The cathode **43** in the form of a longitudinally slotted tube which is embedded in the peripheral wall portion **183**, this being achieved by moulding the insulator around the cathode. The cathode has eight equally spaced longitudinal slots **191** so that it is essentially comprised of eight cathode strips **192** disposed between the slots and connected together at top and bottom only, the slots being filled with the insulating material of insulator **183**.

Both the anode and cathode are made of nickel plated mild steel. The outer periphery of the anode is machined to form eight circumferentially spaced flutes **193** which have arcuate roots meeting at sharp crests or ridges **194** defined between the flutes. The eight anode crests **194** are radially aligned centrally of the cathode strips **192** and the perimeter of the anode measured along its external surface is equal to the combined widths of the cathode strips measured at the internal surfaces of these strips, so that over the major part of their lengths the anode and cathode have equal effective areas. This equalisation of areas generally have not been available in prior art cylindrical anode/cathode arrangements.

As most clearly seen in Fig.27 the upper end of anode **42** is relieved and fitted with an annular collar **200** the outer periphery of which is shaped to form an extension of the outer peripheral surface of the fluted anode. This collar is formed of an electrically insulated plastics material such as polyvinyl chloride or teflon. A locating pin **205** extends through collar **200** to project upwardly into an opening in upper insulating plate **182** and to extend down into a hole **210** in the cathode. The collar is thus located in correct annular alignment relative to the anode and the anode is correctly aligned relative to the cathode.

The annular space **195** between the anode and cathode serves as the electrolyte solution chamber. Initially this chamber is filled approximately 75% full with an electrolyte solution of 25% potassium hydroxide in distilled water. As the electrolysis reaction progresses hydrogen and oxygen gases collect in the upper part of this chamber and water is admitted to maintain the level of electrolyte solution in the chamber. Insulating collar **200** shields the

cathode in the upper region of the chamber where hydrogen and oxygen gases collect to prevent any possibility of arcing through these gases between the anode and cathode.

Electrolyte chamber **195** is divided by a tubular membrane **196** formed by nylon woven mesh material **408** stretched over a tubular former **197** formed of very thin sheet steel. As most clearly illustrated in **Fig.20** and **Fig.21** former **197** has upper and lower rim portions **198**, **199** connected by circumferentially spaced strip portions **201**. The nylon mesh material **408** may be simply folded around the upper and lower insulators **182**, **183** so that the former is electrically isolated from all other components of the cell. Material **408** has a mesh size which is so small that the mesh openings will not pass bubbles of greater than 0.004 inch diameter and the material can therefore serve as a barrier against mixing of hydrogen and oxygen generated at the cathode and anode respectively while permitting the electrolytic flow of current between the electrodes. The upper rim portion **198** of the membrane former **197** is deep enough to constitute a solid barrier through the depth of the gas collection chamber above the electrolyte solution level so that there will be no mixing of hydrogen and oxygen within the upper part of the chamber.

Fresh water is admitted into the outer section of chamber **195** via an inlet nozzle **211** formed in upper closure plate **178**. The electrolyte solution passes from the outer to the inner sections of chamber **195** through the mesh membrane **408**.

Nozzle **211** has a flow passage **212** extending to an electrolyte inlet valve **213** controlled by a float **214** in chamber **195**. Valve **213** comprises a bushing **215** mounted within an opening extending down through upper closure plate **179** and the peripheral flange **185** of upper insulator **182** and providing a valve seat which cooperates with valve needle **216**. Needle **216** rests on a pad **217** on the upper end of float **214** so that when the electrolyte solution is at the required level the float lifts the needle hard against the valve seat. The float slides vertically on a pair of square section slide rods **218** extending between the upper and lower insulators **182** and **183**. These rods, which may be formed of polytetrafluoroethylene extend through appropriate holes **107** through the float.

The depth of float **214** is chosen such that the electrolyte solution fills only approximately 75% of the chamber **195**, leaving the upper part of the chamber as a gas space which can accommodate expansion of the generated gas due to heating within the cell.

As electrolysis of the electrolyte solution within chamber **195** proceeds, hydrogen gas is produced at the cathode and oxygen gas is produced at the anode. These gases bubble upwardly into the upper part of chamber **195** where they remain separated in the inner and outer compartments defined by membrane and it should be noted that the electrolyte solution enters that part of the chamber which is filled with oxygen rather than hydrogen so there is no chance of leakage of hydrogen back through the electrolyte inlet nozzle.

The abutting faces of upper closure plates **178**, **179** have matching annular grooves forming within the upper closure inner and outer gas collection passages **221**, **222**. Outer passage **222** is circular and it communicates with the hydrogen compartment of chamber **195** via eight ports **223** extending down through top closure plate **179** and the peripheral flange of upper insulator **182** adjacent the cathode strips **192**. Hydrogen gas flows upwardly through ports **223** into passage **222** and thence upwardly through a one-way valve **224** (**Fig.19**) into a reservoir **225** provided by a plastic housing **226** bolted to top closure plate **178** via a centre stud **229** and sealed by a gasket **227**. The lower part of housing **114** is charged with water. Stud **229** is hollow and its lower end has a transverse port **228** so that, on removal of a sealing cap **229** from its upper end it can be used as a filter down which to pour water into the reservoir **225**. Cap **229** fits over a nut **231** which provides the clamping action on plastic housing **226** and resilient gaskets **232**, **233** and **234** are fitted between the nut and cover, between the cap and the nut and between the cap and the upper end of stud **229**.

One-way valve **224** comprises a bushing **236** which projects down into the annular hydrogen passage **221** and has a valve head member **237** screw fitted to its upper end to provide clamping action on top closure plate **178** between the head member and a flange **238** at the bottom end bushing **236**. Bushing **236** has a central bore **239**, the upper end of which receives the diamond cross-section stem of a valve member **240**, which also comprises a valve plate portion **242** biased against the upper end of the bushing by compression spring **243**. Valve member **240** is lifted against the action of spring **243** by the pressure of hydrogen gas within passage **221** to allow the gas to pass into the interior of valve head **237** and then out through ports **220** in that member into reservoir **225**.

Hydrogen is withdrawn from reservoir **225** via a stainless steel crooked tube **241** which connects with a passage **409**. Passage **409** extends to a port **250** which extends down through the top and bottom closure plates **178**, **179** and top insulator **182** into a hydrogen duct **244** extending vertically within the casting of casing **171**. Duct **244** is of triangular cross-section. As will be explained below, the hydrogen passes from this duct into a mixing chamber defined in the gas mixing and delivery unit **38** which is bolted to casing **171**.

Oxygen is withdrawn from chamber **195** via the inner annular passage **221** in the top closure. Passage **221** is not circular but has a scalloped configuration to extend around the water inlet. Oxygen enters it through eight ports **245** extended through top closure plate **179** and the annular flange portion of upper insulator **182**. The oxygen flows upwardly from passage **222** through a one-way valve **246** and into a reservoir **260** provided by a plastic housing **247**. The arrangement is similar to that for withdrawal of hydrogen and will not be described in great detail. Suffice to say that the bottom of the chamber is charged with water and the oxygen is withdrawn through a crooked tube **248**, an outlet passage **249** in top closure plate **178**, and a port which extends down through closure plates **178**, **179** and top insulator **182** into a triangular cross-section oxygen duct **251** extending vertically within casing **171** disposed opposite hydrogen duct **244**. The oxygen is also delivered to the gas mixing chamber of the mixing and delivery unit **38**.

The pressure sensing tube **63** for switch **62** is connected via a tapered thread connector **410** and a passage **411** in the top closure plate **178** directly to the annular hydrogen passage **222**. If the pressure within the passage rises above a predetermined level, switch **62** is operated to disconnect capacitor **C2** from the common negative line **54**. This removes the negative signal from capacitor **C2** which is necessary to maintain continuous operation of the pulse generating circuitry for generating the triggering pulses on thyristor **T1** and these triggering pulses therefore cease. The transformer **TR1** continues to remain in operation to charge dumping capacitor **C5** but because thyristor **T1** cannot be triggered dumping capacitor **C5** will simply remain charged until the hydrogen pressure in passage **222**, and therefore in chamber **195** falls below the predetermined level and triggering pulses are applied once more to thyristor **T1**. Pressure actuated switch **62** thus controls the rate of gas production according to the rate at which it is withdrawn. The stiffness of the control springs for gas escape valves **224**, **246** must of course be chosen to allow escape of the hydrogen and oxygen in the proportions in which they are produced by electrolysis, i.e. in the ratios 2:1 by volume.

Reservoirs **225**, **260** are provided as a safety precaution. If a sudden back-pressure were developed in the delivery pipes this could only shatter the plastic housings **226**, **247** and could not be transmitted back into the electrolytic cell. Switch **62** would then operate to stop further generation of gases within the cell.

The electrical connections of secondary transformer coil **89** to the anode and the cathode are shown in **Fig.14**. One end of coil **89** is extended as a wire **252** which extends into a blind hole in the inner face of the anode where it is gripped by a grub screw **253** screwed into a threaded hole extended vertically into the anode underneath collar **200**. A tapered nylon plug **254** is fitted above screw **253** to seal against loss of oil from the interior of the anode. The other end of coil **89** is extended as a wire **255** to pass down through a brass bush **256** in the bottom insulator **183** and then horizontally to leave casing **171** between bottom insulating disc **176** and insulator **183**.

As most clearly shown in **Fig.23**, brass bush **256** has a head flange **257** and is fitted at its lower end with a nut **258** whereby it is firmly clamped in position. Gaskets **259**, **261** are disposed beneath head flange **257** and above nut **258** respectively.

At the location where wire **255** is extended horizontally to leave the casing the upper face of disc **176** and the lower face of insulator **183** are grooved to receive and clamp onto the wire. Disc **176** and insulator **183** are also extended radially outwardly at this location to form tabs which extend out beneath casing **171** and ensure proper insulation of the wire through to the outer periphery of the casing.

Outside the casing, wire **255** is connected to a cathode terminal bolt **262**. Terminal bolt **262** has a head which is received in a socket in separate head piece **263** shaped to suit the cylindrically curved inner periphery of the cathode and nickel plated to resist chemical attack by the electrolyte solution. The stem of the terminal bolt extends through openings in the cathode and peripheral wall portion **188** of insulator **183** and air insulating bush fitted in an aligned opening in the casing wall **172**. The head piece **263** of the terminal bolt is drawn against the inner periphery of the cathode by tightening of a clamping nut **265** and the end of wire **255** has an eye which is clamped between nut **265** and a washer **266** by tightening a terminal end nut **267**. A washer **268** is provided between nut **265** and brush **264** and a sealing O-ring **269** is fitted in an annular groove in the bolt stem to engage the inner periphery of the bush in order to prevent escape of electrolyte solution. The terminal connection is covered by a cover plate **271** held in place by fixing screws **272**.

The two ends of the primary transformer coil **88** are connected to strip conductors **273**, **274** which extend upwardly through the central portion of upper insulator **183**. The upper ends of conductors **273**, **274** project upwardly as pins within a socket **275** formed in the top of upper insulator **183**. The top of socket **275** is closed by a cover **276** which is held by a centre stud **277** and through which wires **278**, **279** from the external circuit are extended and connected to conductors **273**, **274** by push-on connectors **281**, **282**.

The transformer connections shown in **Fig.14** are in accordance with the circuit of **Fig.2**, i.e. the ends of secondary coil **89** are connected directly between the anode and the cathode. Transformer **TR2** is a step-down

transformer and, assuming an input of pulses of 22 amps at 300 volts and a coil ratio between the primary and secondary of 10:1 the output applied between the anode and the cathode will be pulses of 200 amps at a low voltage of the order of 3 volts. The voltage is well in excess of that required for electrolysis to proceed and the very high current achieved produces a high rate of yield of hydrogen and oxygen. The rapid discharge of energy which produces the large current flow will be accompanied by a release of heat. This energy is not entirely lost in that the consequent heating of the electrolyte solution increases the mobility of the ions which tends to increase the rate of electrolysis.

The configuration of the anode and cathode arrangement of electrolytic cell **41** is of significant importance. The fluted external periphery of the anode causes a concentration of current flow which produces a better gas yield over a given electrode area. This particular configuration also causes the surface area of the anode to be extended and permits an arrangement in which the anode and cathode have equal surface areas which is most desirable in order to minimise electrical losses. It is also desirable that the anode and cathode surfaces at which gas is produced be roughened, for example by sand-blasting. This promotes separation of the gas bubbles from the electrode surfaces and avoids the possibility of overvoltages.

The arrangement of the secondary transformer in which the central anode is surrounded by the cathode is also of great importance. The anode, being constructed of a magnetic material, is acted on by the magnetic field of transformer **TR2** to become, during the period of energisation of that transformer, a strong conductor of magnetic flux. This in turn creates a strong magnetic field in the inter-electrode space between the anode and the cathode. It is believed that this magnetic field increases the mobility of the ions in solution thereby improving the efficiency of the cell.

The heat generated by transformer **TR2** is conducted via the anode to the electrolyte solution and increases the mobility of the ions within the electrolyte solution as above mentioned. The cooling fins **180** are provided on casing **171** to assist in dissipation of excess generated heat. The location of the transformer within the anode also enables the connections of the secondary coil **89** to the anode and cathode to be made of short, well protected conductors.

As mentioned above the hydrogen and oxygen gas generated in electrolytic cell **41** and collected in ducts **244**, **251** is delivered to a gas mixing chamber of the mixing and delivery unit **38**. More specifically, these gases are delivered from ducts **244**, **251** via escape valves **283**, **284** (**Fig.15**) which are held in position over discharge ports **285**, **286** from the ducts by means of a leaf spring **287**. The outer ends of spring **287** engage the valves **283**, **284** and the centre part of the spring is bowed inwardly by a clamping stud **288** screwed into a tapped hole in a boss **289** formed in the cell casing **171**.

Valve **283** is detailed in **Fig.28** and **Fig.29** and valve **284** is of identical construction. Valve **283** includes an inner valve body **291** having a cap portion **292** and an annular end ring portion **293** which holds an annular valve seat **294**. A valve disc **295** is biased against the valve seat by a valve spring **296** reacting against the cap portion **292**. An outer valve cover **297** fits around the inner member **291** and is engaged by spring **287** to force the inner member firmly into a socket in the wall of the cell casing so to cover the hydrogen discharge port **285**. The end ring portion **293** of the inner body member beds on a gasket **298** within the socket.

During normal operation of the apparatus valves **283**, **284** act as simple one-way valves by movements of their spring loaded valve plates. However, if an excessive gas pressure should arise within the electrolytic cell these valves will be forced back against the action of holding spring **287** to provide pressure relief. The escaping excess gas then flows to atmosphere via the mixing and delivery unit **38** as described below. The pressure at which valves **283**, **284** will lift away to provide pressure relief may be adjusted by appropriate setting of stud **288**, which setting is held by a nut **299**.

The construction of the gas mixing and delivery unit **38** is shown in **Fig.30** and **Fig.40**. It comprises an upper body portion **301** which carries an air filter assembly **302**, an intermediate body portion **303**, which is bolted to the casing of electrolytic cell **41** by six studs **304**, and successive lower body portions **305**, **300**, the latter of which is bolted to the inlet manifold of the engine by four studs **306**.

The bolted connection between intermediate body portion **303** and the casing of the electrolytic cell is sealed by a gasket **307**. This connection surrounds valves **283**, **284** which deliver hydrogen and oxygen gases directly into a mixing chamber **308** (**Fig.34**) defined by body portion **303**. The gases are allowed to mix together within this chamber and the resulting hydrogen and oxygen mixture passes along small diameter horizontal passageway **309** within body portion **303** which passageway is traversed by a rotary valve member **311**. Valve member **311** is conically tapered and is held within a correspondingly tapered valve housing by a spring **312** (**Fig.38**) reacting against a bush **313** which is screwed into body portion **303** and serves as a mounting for the rotary valve stem **314**. Valve member **311** has a diametral valve port **315** and can be rotated to vary the extent to which this port is

aligned with passageway **309** thereby to vary the effective cross-section for flow through that passageway. As will be explained below, the rotational positions of the valve member is controlled in relation to the engine speed.

Passage **309** extends to the lower end of a larger diameter vertical passageway **316** which extends upwardly to a solenoid freed valve **310** incorporated in a valve and jet assembly denoted generally as **317**.

Assembly **317** comprises a main body **321** (**Fig.32**) closed at the top by a cap **322** when the assembly is clamped to body portion **303** by two clamping studs **323** to form a gas chamber **324** from which gas is to be drawn through jet nozzles **318** into two vertical bores or throats **319** (**Fig.31**) in body portion **303**. The underside of body **321** has a tapped opening into which is fitted an externally screw threaded valve seat **325** of valve **310**. A valve member **326** is biased down against seat **325** by a spring **327** which reacts against cap **322**. Spring **327** encircles a cylindrical stem **328** of valve member **326** which stem projects upwardly through an opening in cap **322** so that it may be acted on by solenoid **56** which is mounted immediately above the valve in upper body portion **301**.

Solenoid **56** is comprised of an outer insulating casing **366** which has two mounting flanges **367**. This casing houses the copper windings constituting coil **55**. These are wound on a plastic bobbin **369** disposed about a central mild steel core **371**. The core has a bottom flange **372** and the bobbin and coils are held clamped in the casing through insulating closure **373** acted on by flange **372** on tightening of a clamping nut **374** which is fitted to the other end of the core.

Upper body portion **301** of unit **38** is tubular but at one side it has an internal face shaped to suit the exterior profile of solenoid casing **366** and mounting flanges **367**. Two mounting screws **375** screw into holes in this face and engage slots **376** in the mounting flanges **367** so that the height of the solenoid above valve **310** can be adjusted. The two terminals **377** are connected into the electrical circuit by wires (not shown) which may be extended into unit **38** via the air filter assembly.

When solenoid **56** is energised its magnetised core attracts valve stem **328** and valve member **326** is lifted until stem **328** abuts the lower flange **372** of the solenoid core. Thus valve **310** is opened when the ignition switch is closed and will close under the influence of spring **327** when the ignition switch is opened. Vertical adjustment of the solenoid position controls the lift of valve member **326** and therefore the maximum fuel flow rate through unit **38**.

Electrolyte cell **41** produces hydrogen in the ratio 2:1 to provide a mixture which is by itself completely combustible. However, as used in connection with existing internal combustion engines the volume of hydrogen and oxygen required for normal operation is less than that of a normal fuel air mixture. Thus a direct application to such an engine of only hydrogen and oxygen in the amount required to meet power demands will result in a vacuum condition within the system. In order to overcome this vacuum condition provision is made to draw make-up air into throats **319** via the air filter assembly **302** and upper body portion **301**.

Upper body portion **301** has a single interior passage **328** through which make-up air is delivered to the dual throats **319**. It is fastened to body portion **303** by clamping studs **329** and a gasket **331** is sandwiched between the two body portions. The amount of make-up air admitted is controlled by an air valve flap **332** disposed across passage **328** and rotatably mounted on a shaft **333** to which it is attached by screws **334**. The valve flap is notched to fit around solenoid casing **366**. Shaft **333** extends through the wall of body portion **301** and outside that wall it is fitted with a bracket **335** which carries an adjustable setting screw **336** and a biasing spring **337**. Spring **337** provides a rotational bias on shaft **333** and during normal running of the engine it simply holds flap **332** in a position determined by engagement of setting screw **336** with a flange **338** of body portion **301**. This position is one in which the flap almost completely closes passage **328** to allow only a small amount of make-up air to enter, this small amount being adjustable by appropriate setting of screw **336**. Screw **336** is fitted with a spring **339** so that it will hold its setting.

Although flaps **332** normally serve only to adjust the amount of make-up air admitted to unit **38**, it also serves as a pressure relief valve if excessive pressures are built up, either due to excessive generation of hydrogen and oxygen gases or due to burning of gases in the inlet manifold of the engine. In either event the gas pressure applied to flaps **332** will cause it to rotate so as to open passage **328** and allow gases to escape back through the air filter. It will be seen in **Fig.32** that flap mounting shaft **333** is offset from the centre of passage **328** such that internal pressure will tend to open the flap and thus exactly the reverse of the air valve in a conventional gasoline carburettor.

Air filter assembly **302** comprises an annular bottom pan **341** which fits snugly onto the top of upper body portion **301** and domed filter element **342** held between an inner frame **343** and an outer steel mesh covering **344**. The assembly is held in position by a wire and eyebolt fitting **345** and clamping nut **346**.

Body portion **305** of unit **38** (**Fig.31**), which is fastened to body portion **303** by clamping studs **347**, carries throttle

valve apparatus to control engine speed. It has two vertical bores **348, 349** serving as continuations of the dual throats which started in body portion **303** and these are fitted with throttle valve flaps **351, 352** fixed to a common throttle valve shaft **353** by fixing screws **354**. Both ends of shaft **353** are extended through the wall of body portion **305** to project outwardly therefrom. One end of this shaft is fitted with a bracket **355** via which it is connected as in a conventional carburettor to a throttle cable **356** and also to an automatic transmission kick-down control linkage **357**. A biasing spring **358** acts on shaft **353** to bias throttle flaps toward closed positions as determined by engagement of a setting screw **359** carried by bracket **355** with a plate **361** projecting from body portion **303**.

The other end of throttle valve shaft **353** carries a lever **362** the outer end of which is connected to a wire link **407** by means of which a control connection is made to the valve stem **314** of valve member **311** via a further lever **406** connected to the outer end of the valve stem. This control connection is such that valve member **311** is at all times positioned to pass a quantity of gas mixture appropriate to the engine speed as determined by the throttle setting. The initial setting of valve member **311** can be adjusted by selection between two connection holes **405** in lever **406** and by bending of link **407**.

Body portion **303** is fastened to the bottom body portion **300** of unit **38** by four clamping studs **306**. The bottom body portion has two holes **364, 365** which form continuations of the dual throats and which diverge in the downward direction so as to direct the hydrogen, oxygen and air mixture delivered through these throats outwardly toward the two banks of cylinder inlets. Since this fuel is dry, a small quantity of oil vapour is added to it via a passage **403** in body portion **305** to provide some upper cylinder lubrication. Passage **403** receives oil vapour through a tube **404** connected to a tapping on the engine tapped cover. It discharges the oil vapour down on to a relieved top face part **368** of body portion **300** between holes **364, 365**. The vapour impinges on the relieved face part and is deflected into the two holes to be drawn with the gases into the engine.

In the illustrated gas mixing and delivery unit **38**, it will be seen that passageway **309**, vertical passageway **316**, chamber **324** and nozzles **318** constitute transfer passage means via which the hydrogen mixture pass to the gas flow duct means comprised of the dual throats via which it passes to the engine. The transfer passage means has a gas metering valve comprised of the valve member **311** and the solenoid operated valve is disposed in the transfer passage means between the metering valve and the gas flow duct means. The gas metering valve is set to give maximum flow rate through the transfer passage means at full throttle setting of throttle flaps **351, 352**. The solenoid operated valve acts as an on/off valve so that when the ignition switch is opened the supply of gas to the engine is positively cut-off thereby preventing any possibility of spontaneous combustion in the cylinders causing the engine to "run on". It also acts to trap gas in the electrolytic cell and within the mixing chamber of the mixing and delivery unit so that gas will be available immediately on restarting the engine.

Dumping capacitor **C5** will determine a ratio of charging time to discharge time which will be largely independent of the pulse rate and the pulse rate determined by the oscillation transistor **Q1** must be chosen so that the discharge time is not so long as to produce overheating of the transformer coils and more particularly the secondary coil 89 of transformer **TR2**. Experiments indicate that overheating problems are encountered at pulse rates below about 5,000 and that the system will behave much like a DC system, with consequently reduced performance at pulse rates greater than about 40,000. A pulse rate of about 10,000 pulses per minute will be nearly optimum. With the saw tooth wave input and sharply spiked output pulses of the preferred oscillator circuit the duty cycle of the pulses produced at a frequency of 10,000 pulses per minute was about 0.006. This pulse form helps to minimise overheating problems in the components of the oscillator circuit at the high pulse rates involved. A duty cycle of up to 0.1, as may result from a square wave input, would be feasible but at a pulse rate of 10,000 pulses per minute some of the components of the oscillator circuit would then be required to withstand unusually high heat inputs. A duty cycle of about 0.005 would be a minimum which could be obtained with the illustrated type of oscillator circuitry.

From the foregoing description it can be seen that the electrolytic cell **41** converts water to hydrogen and oxygen whenever ignition switch **44** is closed to activate solenoid **51**, and this hydrogen and oxygen are mixed in chamber **308**. Closure of the ignition switch also activates solenoid **56** to permit entry of the hydrogen and oxygen mixture into chamber **319**, when it mixes with air admitted into the chamber by air valve flap **332**. As described above, air valve flap **332** may be set to admit air in an amount as required to avoid a vacuum condition in the engine.

In operation the throttle cable **356** causes bracket **355** to pivot about throttle valve shaft **353**, which rotates flap **351** to control the amount of hydrogen-oxygen-air mixture entering the engine. At the same time shaft **353** acts via the linkage shown in **Fig.37** to control the position of shaft **314**, and shaft **314** adjusts the amount of hydrogen-oxygen mixture provided for mixing with the air. As shown in **Fig.30**, bracket **355** may also be linked to a shaft **357**, which is connected to the car transmission. Shaft **357** is a common type of shaft used for down shifting into a passing gear when the throttle has been advanced beyond a predetermined point. Thus there is provided a

compact fuel generation system which is compatible with existing internal combustion engines and which has been designed to fit into a standard passenger car.

While the form of apparatus herein described constitutes a preferred embodiment of the invention, it is to be understood that the invention is not limited to this precise form of apparatus, and that changes may be made therein without departing from the scope of the invention.

CLAIMS

1. For an internal combustion engine having inlet means to receive a combustible fuel, fuel supply apparatus comprising:

a vessel to hold an aqueous electrolyte solution;

an anode and a cathode to contact the electrolyte solution within the vessel;

electrical supply means to apply between said anode and said cathode pulses of electrical energy to induce a pulsating current in the electrolyte solution thereby to generate by electrolysis hydrogen and oxygen gases;

gas collection and delivery means to collect the hydrogen and oxygen gases and to direct them to the engine inlet means; and

water admission means to admit water to said vessel;

said electrical supply means comprising a source of direct current electrical energy of substantially uniform voltage and current and electrical converter means to convert that energy to said pulses, said converter means comprising a transformer means having primary coil means energised by direct current energy from said source and secondary coil means inductively coupled to the primary coil means; a dump capacitor connected to the secondary coil means of the transformer means so as to be charged by electrical output of that coil means; oscillator means to derive electrical pulses from direct current energy of said source; a switching device switchable from a non-conducting state to a conducting state in response to each of the electrical pulses derived by the oscillator means and connected to the secondary coil means of the transformer means and the dump capacitor such that each switching from its non-conducting state to its conducting state causes the dump capacitor to discharge and also short circuits the transformer means to cause the switching means to revert to its non-conducting state; and electrical conversion means to receive the pulse discharges from the dump capacitor and to convert them to said pulses of electrical energy which are applied between the anode and cathode.

2. Fuel supply as claimed in claim 1, wherein the electrical supply means applies said pulses of electrical energy at a frequency of ranging between about 5,000 and 40,000 pulses per minute.

3. Fuel supply apparatus as claimed in claim 2, wherein the electrical supply means applies said pulses of electrical energy at a frequency of about 10,000 pulses per minute.

4. Fuel supply apparatus as claimed in claim 2, wherein the electrical supply means comprises a source of direct current electrical energy of substantially uniform voltage and current and electrical converter means to convert that energy to said pulses.

5. Fuel supply apparatus as claimed in claim 1, wherein the electrical conversion means is a voltage step-down transformer comprising a primary coil to receive the pulse discharge from said dump capacitor and a secondary coil electrically connected between the anode and cathode and inductively coupled to the primary coil.

6. Fuel supply apparatus as claimed in claim 5, wherein said cathode encompasses the anode.

7. Fuel supply apparatus as claimed in claim 1, wherein the cathode encompasses the anode which is hollow and the primary and secondary coils of the second transformer means are disposed within the anode.

8. Fuel supply apparatus as claimed in claim 1, wherein the anode is tubular and its ends are closed to form a chamber which contains the primary and secondary coils of the second transformer means and which is charged with oil.

9. In combination with an internal combustion engine having an inlet for combustible fuel, fuel supply apparatus comprising:

a. an electrolytic cell to hold an electrolytic conductor;

b. a first hollow cylindrical electrode disposed within said cell and provided about its outer surface with a series of circumferentially spaced and longitudinally extending flutes;

c. a second hollow cylindrical electrode surrounding said anode and segmented into a series of electrically connected longitudinally extending strip; said strips being equal in number to the number of said flutes, said strips having a total active surface area approximately equal to the total active surface area of said flutes, and said strips being in radial alignment with the crests of said flutes;

d. current generating means for generating a flow of electrolysing current between said first and second electrodes;

e. gas collection and delivery means to collect hydrogen and oxygen gases from the cell and to direct them to said fuel inlet of the engine; and

f. water admission means to admit water to the cell.

10. The combination claimed in claim 9, wherein said current generating means comprises a transformer situated inside said first electrode.

11. The combination claimed in claim 10, wherein the secondary winding of said transformer is connected whereby said first electrode operates as an anode and said second electrode operates as a cathode.

12. The combination claimed in claim 11, wherein said current generating means further comprising means to generate a pulsed current in the primary winding of said transformer.

13. The combination claimed in claim 9, wherein the roots of said flutes are cylindrically curved.

14. The combination claimed in claim 10, wherein said current generating means comprises a source of direct current; a transformer means having primary coil means energised by direct current energy from said source and secondary coil means inductively coupled to the primary coil means; a dump capacitor connected to the secondary coil means of the transformer means so as to be charged by electrical output of that coil means; oscillator means to derive electrical pulses from direct current energy of said source, a switching device switchable from a non-conducting state to a conducting state in response to each of the electrical pulses derived by the oscillator means and connected to the secondary coil means of the transformer means and the dump capacitor such that each switching from its non-conducting state to its conducting state causes the dump capacitor to discharge and also short circuits the transformer means to cause the switching means to revert to its non-conducting state; and electrical conversion means to receive the pulse discharges from the dump capacitor and to convert them to said pulses of electrical electrical which are applied between said first and second electrodes.

15. The combination claimed in claim 10, wherein the electrical conversion means comprises a voltage step-down transformer having a primary coil to receive the pulse discharge from said dump capacitor and a secondary coil electrically connected between said first and second electrodes.

16. The combination of an internal combustion engine having an inlet to receive a combustible fuel and fuel supply apparatus comprising:

a vessel to hold an aqueous electrolyte solution;

a first hollow cylindrical electrode disposed within said vessel and provided about its outer surface with a series of circumferentially spaced and longitudinally extending flutes;

a second hollow cylindrical electrode surrounding the first electrode and segmented into a series of electrically connected longitudinally extending strips; said strips being equal in number to the number of said flutes and being in radial alignment with the crests of said flutes;

current generating means for generating a pulsating current between said first and second electrodes to produce hydrogen and oxygen gases within the vessel;

gas collection and delivery means to collect the hydrogen and oxygen gases and to direct them to the engine inlet means; and

water admission means to admit water to the vessel.

17. The combination claimed in claim 26, wherein said current generating means comprises a source of direct current; a first transformer means having primary coil means energised by direct current energy from said source and secondary coil means inductively coupled to the primary coil means; a dump capacitor connected to the secondary coil means of the first transformer means so as to be charged by electrical output of that coil means; oscillator means to derive electrical pulses from direct current energy of said source; a switching device switchable from non-conducting state to a conducting state in response to each of the electrical pulses derived by the oscillator means and connected to the secondary coil means of the first transformer means and the dump capacitor such that each switching from its non-conducting state to its conducting state causes the dump capacitor to discharge and also short circuits the first transformer means to cause a second transformer to receive the pulse discharges from the dump capacitor and to transform them to pulses of electrical energy which are applied between said first and second electrodes.

18. The combination claimed in claim 26, wherein the second transformer means has primary coil means energised by the pulse discharges from the dump capacitor and secondary coil means which is inductively coupled to the primary coil means and is connected to the first and second electrodes such that the first electrode operates as an anode and the second electrode operates as a cathode.

The Water Fracture Cell of Christopher Eccles

UK Patent App. 2,324,307 21st October 1998 Inventor: Christopher R. Eccles

FRACTURE CELL APPARATUS

Please note that this is a re-worded extract from the patent and the diagrams have been adapted slightly. It describes a device for splitting water into hydrogen and oxygen gasses via electrolysis using electrodes which are placed on the **outside** of the cell.

ABSTRACT

Fracture cell apparatus including a capacitive fracture cell **20** comprising a container **21** having walls **21a**, and **21b** made of non-electrically conducting material for containing a liquid dielectric **26**, and spaced apart electrodes **22** and **23** positioned outside container **21** with the liquid dielectric **26** between the electrodes, and a mechanism (**8a** and **8b** in **Fig.1** and **Fig.2**) for applying positive and negative voltage pulses to each of the electrodes **22** and **23**. In use, whenever one of a positive voltage pulse and a negative voltage pulse is applied to one of the two electrodes, the other of a positive voltage pulse and a negative voltage pulse is applied to the other of the two electrodes, thereby creating an alternating electric field across the liquid dielectric to cause fracture of the liquid dielectric **26**. The apparatus may be used for generating hydrogen gas.

FRACTURE CELL APPARATUS

This invention relates to a fracture cell apparatus and to a method of generating fuel gas from such fracture cell apparatus. In particular, but not exclusively, the invention relates to an apparatus and method for providing fuel gas from water.

Conventionally, the principal methods of splitting a molecular species into its component atomic constituents have been either purely chemical or purely electrolytic:

Purely chemical reactions always involve "third-party" reagents and do not involve the interaction of (1) an applied external electrical influence, and (2) a simple substance. Conventional electrolysis involves the passage of an electric current through a medium (the electrolyte), such current being the product of ion-transits between the electrodes of the cell. When ions are attracted towards either the cathode or the anode of a conventional electrolytic cell, they either receive or donate electrons on contact with the respective electrode. Such electron exchanges constitute the current during electrolysis. It is not possible to effect conventional electrolysis to any useful degree without the passage of this current; it is a feature of the process.

A number of devices have recently been described which purport to effect "fracture" of, particularly, water by means of resonant electrostatic phenomena. In particular one known device and process for producing oxygen and hydrogen from water is disclosed in US-A-4936961. In this known device a so-called fuel cell water "capacitor" is provided in which two concentrically arranged spaced apart "capacitor" plates are positioned in a container of water, the water contacting, and serving as the dielectric between, the "capacitor" plates. The "capacitor" is in effect a charge-dependent resistor which begins to conduct after a small displacement current begins to flow. The "capacitor" forms part of a resonant charging circuit that includes an inductance in series with the "capacitor". The "capacitor" is subjected to a pulsating, unipolar electric charging voltage which subjects the water molecules within the "capacitor" to a pulsating electric field between the capacitor plates. The "capacitor" remains charged during the application of the pulsating charging voltage causing the covalent electrical bonding of the hydrogen and oxygen atoms within the water molecules to become destabilised, resulting in hydrogen and oxygen atoms being liberated from the molecules as elemental gases.

Such known fracture devices have, hitherto, always featured, as part of their characteristics, the physical contact of a set of electrodes with the water, or other medium to be fractured. The primary method for limiting current flow through the cell is the provision of a high impedance power supply network, and the heavy reliance on the time-domain performance of the ions within the water (or other medium), the applied voltage being effectively "switched off" in each cycle before ion-transit can occur to any significant degree.

In use of such a known system, there is obviously an upper limit to the number of ion-migrations, electron captures, and consequent molecule-to-atom disruptions which can occur during any given momentary application

of an external voltage. In order to perform effectively, such devices require sophisticated current-limiting and very precise switching mechanisms.

A common characteristic of all such known fracture devices described above, which causes them to behave as though they were conventional electrolysis cells at some point in time after the application of the external voltage, is that they have electrodes in actual contact with the water or other medium.

The present invention seeks to provide an alternative method of producing fracture of certain simple molecular species, for example water.

According to one aspect of the present invention there is provided a fracture cell apparatus including a capacitive fracture cell comprising a container having walls made of non-electrically conducting material for containing a liquid dielectric, and spaced apart electrodes positioned outside the container with the liquid dielectric between the electrodes, and a mechanism for applying positive and negative voltage pulses to each of the electrodes so that, whenever one of a positive voltage pulse and a negative voltage pulse is applied to one of the two electrodes, the other voltage pulse is applied to the other electrode, thereby creating an alternating electric field across the liquid dielectric to cause fracture of the liquid dielectric.

In the apparatus of this invention, the electrodes do not contact the liquid dielectric which is to be fractured or disrupted. The liquid to be fractured is the simple dielectric of a capacitor. No purely ohmic element of conductance exists within the fracture cell and, in use, no current flows due to an ion-carrier mechanism within the cell. The required fracture or disruption of the liquid dielectric is effected by the applied electric field whilst only a simple displacement current occurs within the cell.

Preferably the liquid dielectric comprises water, e.g. distilled water, tap water or deuterated water.

Conveniently each electrode comprises a bipolar electrode.

The mechanism for alternately applying positive and negative pulses, provides step voltages alternately to the two electrodes with a short period of time during each charge voltage cycle in which no step voltage is applied to either electrode. Typically, step voltages in excess of 15 kV, typically about 25 kV, on either side of a reference potential, e.g. earth, are applied to the electrodes. In effect, trains of pulses having alternating positive and negative values are applied to the electrodes, the pulses applied to the different electrodes being "phase shifted". In the case where each electrode comprises a bipolar electrode, each bipolar electrode comprising first and second electrode "plates" electrically insulated from each other, a train of positive pulses is arranged to be applied to one electrode plate of each bipolar electrode and a train of negative pulses is arranged to be applied to the other electrode plate of each bipolar electrode. One electrode plate of one bipolar electrode forms a first set with one electrode plate of the other bipolar electrode and the other electrode plate of the one bipolar electrode forms a second set with the other electrode plate of the other bipolar electrode. For each set, a positive pulse is applied to one electrode plate and a negative pulse is applied simultaneously to the other electrode plate. By alternately switching the application of positive and negative pulses from one to the other set of electrode plates, an "alternating" electric field is generated across the dielectric material contained in the container. The pulse trains are synchronised so that there is a short time interval between the removal of pulses from one electrode plate set and the application of pulses to the other electrode plate set.

According to another aspect of the present invention, there is provided a method of generating gas comprising, applying positive and negative voltage pulses alternately to the electrodes (positioned either side of, but not in contact with, a liquid dielectric), the voltage pulses being applied so that, whenever one of a positive voltage pulse and a negative voltage pulse is applied to one of the two electrodes, the other of a positive voltage pulse and a negative voltage pulse is applied to the other of the two electrodes, the applied voltage pulses generating an alternating electric field across the liquid dielectric causing fracture of the liquid dielectric into gaseous media. Preferably, voltages of at least 15 kV, e.g. 25 kV, either side of a reference value, e.g. earth, are applied across the liquid dielectric to generate the alternating electric field.

An embodiment of the invention will now be described by way of example only, with particular reference to the accompanying drawings, in which:

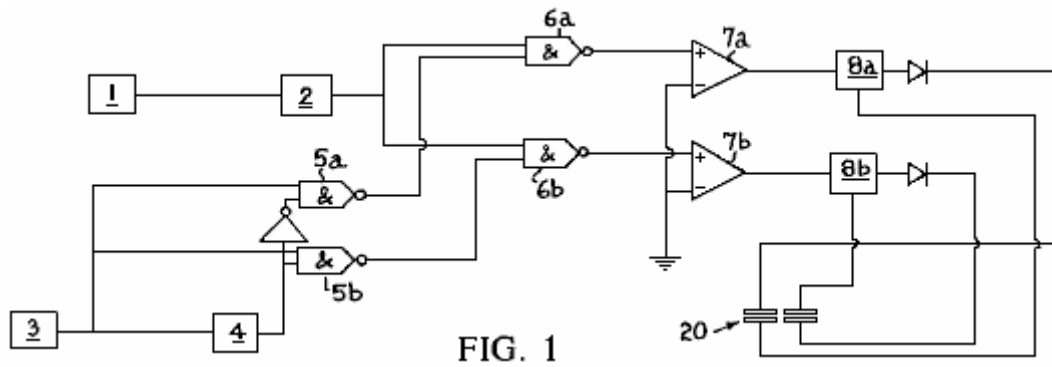

FIG. 1

Fig.1 is a circuit diagram of fracture cell apparatus according to the invention;

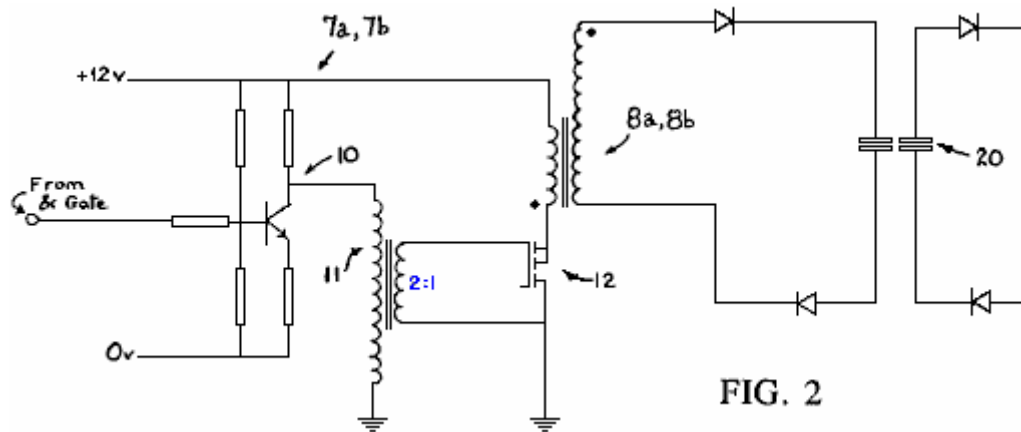

FIG. 2

Fig.2 shows in more detail a part of the circuit diagram of Figure 1;

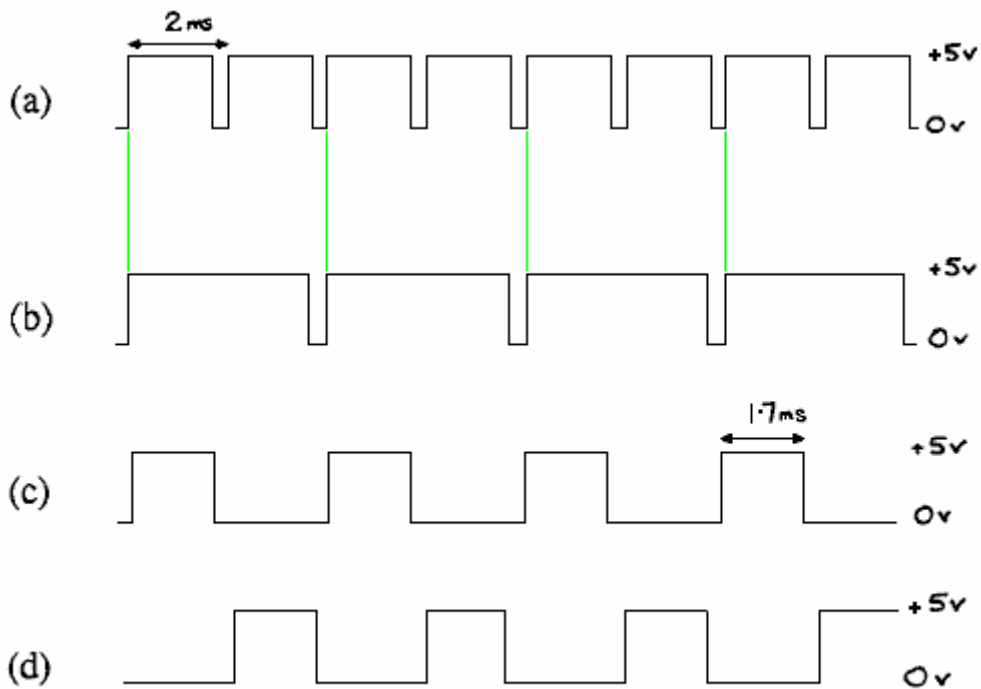

FIG. 3

Fig.3 shows the different waveforms at various parts of the circuit diagram of Fig.1;

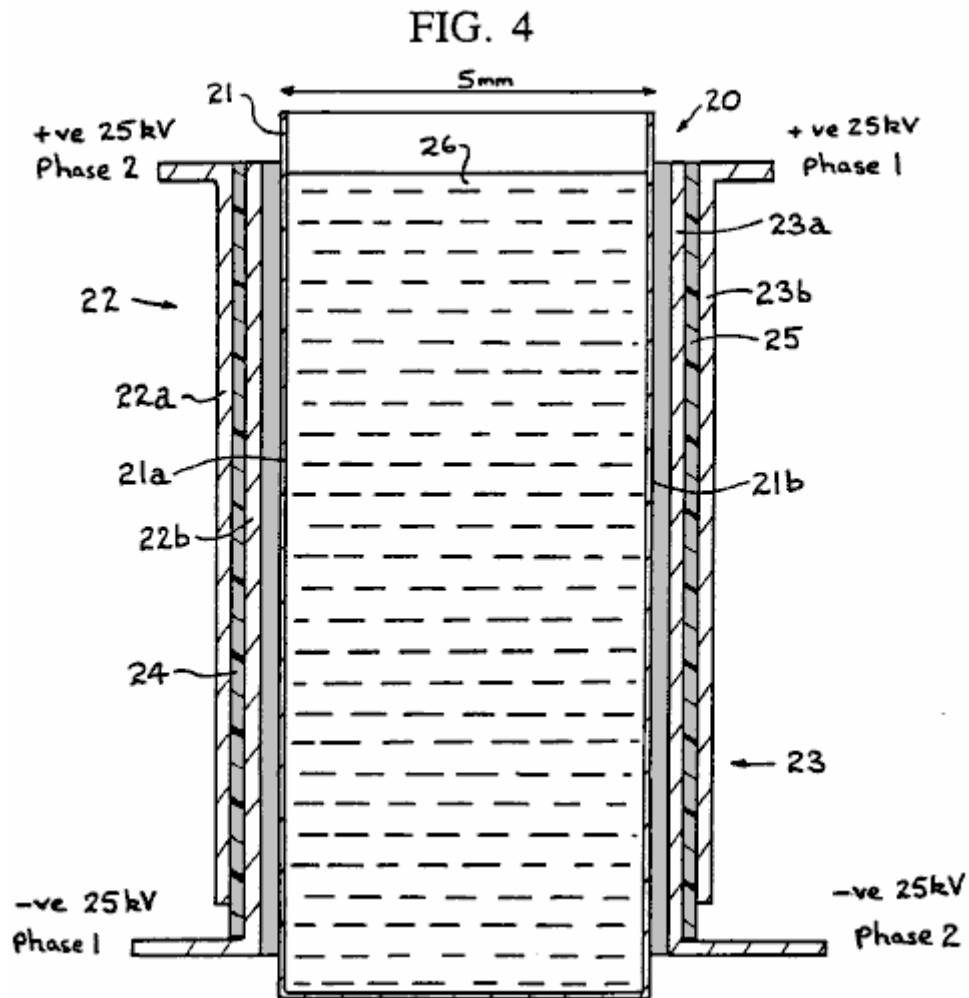

Fig.4 is a schematic diagram of a fracture cell for use in fracture cell apparatus according to the invention,

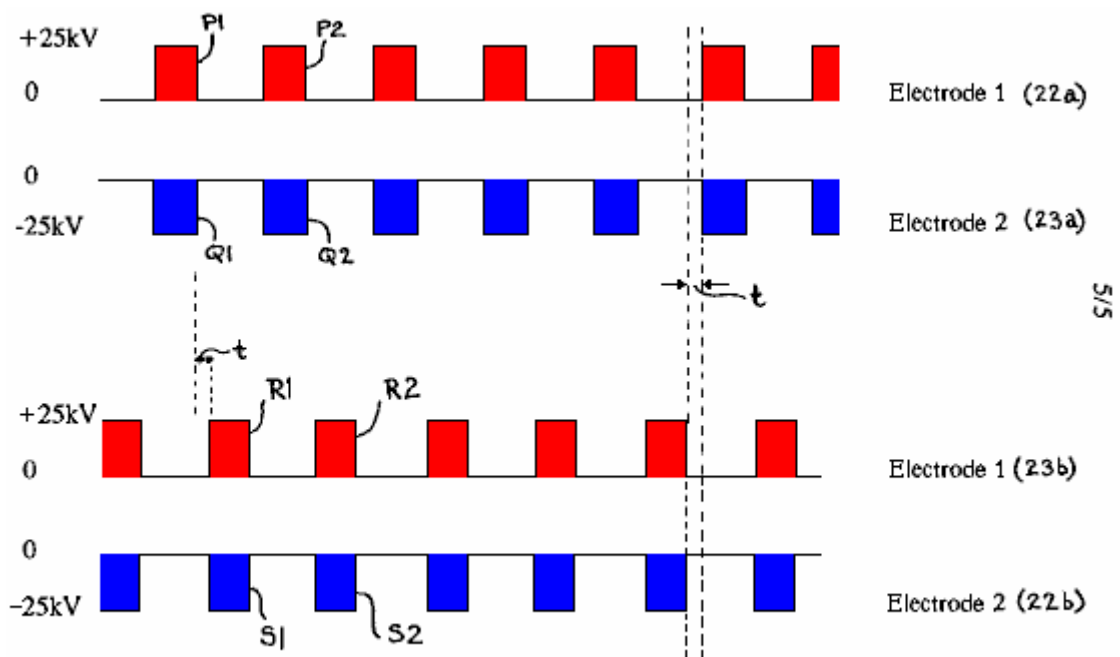

FIG. 5

Fig.5 shows trains of pulses applied to electrodes of the fracture cell apparatus according to the invention.

If a large electric field is applied across a pair of electrode plates positioned either side of a cell containing water, disruption of the water molecules will occur. Such disruption yields hydrogen nuclei and HO⁻ ions. Such a molecular disruption is of little interest in terms of obtaining a usable result from the cell. A proton-rich zone exists for as long as the field exists and quickly re-establishes equilibrium ion-product when the field is removed.

One noticeable side-effect, however, is that the hydroxyl ions (which will migrate to the +ve charged plate) are stripped of electrons as they approach the cell boundary. Any negatively-charged ion will exhibit this behaviour in a strong enough potential well, but the OH ions have a strong tendency to such dissociation. This results, momentarily, in a region of negative-charge close to the positive cell boundary. Thus, on opposite sides of the active cell, there are hydrogen nuclei (free proton zone) and displaced electrons (-ve charge zone), both tending to increase in density closer to the charged plates.

If, at this point, the charge is removed from the plates, there is a tendency for the charge-zones to move, albeit very slowly, towards the centre of the active cell. The ion-transit rates of free electrons and of hydrogen nuclei are, however, some two orders of magnitude greater than either H³⁰⁺ ions or OH ions.

If the charges are now replaced on the plates, but with opposite polarity, the interesting and potentially useful aspect of the process is revealed. Hydrogen nucleus migration is accelerated in the direction of the new -ve plate and free electron migration takes place towards the new +ve plate. Where there is a sufficient concentration of both species, including the accumulations due to previous polarity changes, monatomic hydrogen is formed with the liberation of some heat energy. Normal molecular association occurs and H₂ gas bubbles off from the cell.

Also existing OH radicals are further stripped of hydrogen nuclei and contribute to the process. Active, nascent O⁻ ions rapidly lose their electronic space charge to the +ve field and monatomic oxygen forms, forming the diatomic molecule and similarly bubbling off from the cell.

Thus, the continuous application of a strong electric field, changing in polarity every cycle, is sufficient to disrupt water into its constituent gaseous elements, utilising a small fraction of the energy required in conventional electrolysis or chemical energetics, and yielding heat energy of the enthalpy of formation of the diatomic bonds in the hydrogen and oxygen.

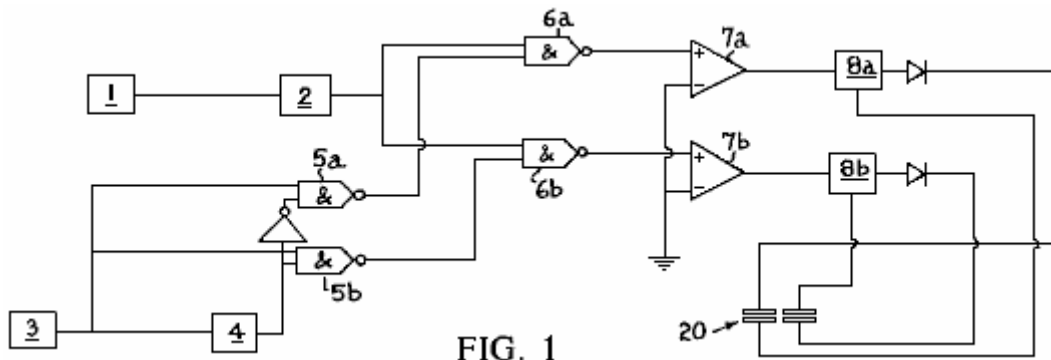

FIG. 1

Apparatus for performing the above process is described below. In particular, electronic circuitry to effect the invention is shown in the simplified block diagram of **Fig.1**. In **Fig.1** a pulse-repetition frequency (PRF) generator **1** comprises an astable multivibrator clock running at a frequency which is preset for any application, but able to be varied across a range of approximately 5-30 kHz. The generator **1** drives, by triggering with the trailing edge of its waveform, a pulse-width (PW) timer **2**.

The output of the timer **2** is a train of regular pulses whose width is determined by the setting of timer **2** and whose repetition frequency is set by the PRF generator **1**.

A gate clock **3** comprises a simple 555-type circuit which produce a waveform (see **Fig.3a**) having a period of 1 to 5 ms, e.g. 2 ms as shown in **Fig.3a**. The duty cycle of this waveform is variable from 50% to around 95%. The waveform is applied to one input of each of a pair of AND gates **5a** and **5b** and also to a binary divide-by-two counter **4**. The output of the counter **4** is shown in **Fig.3b**.

The signal from the divide-by-two counter **4** is applied directly to the AND gate **5b** serving phase-2 driver circuitry **7a** but is inverted before application to the AND gate **5a** serving phase-1 driver circuitry **7a**. The output of the AND gate **5a** is therefore ((CLOCK and (NOT (CLOCK)/2)) and the output of the AND gate **5b** is ((CLOCK and (CLOCK/2)), the waveforms, which are applied to pulse-train gates **6a** and **6b**, being shown in **Fig.3c** and **Fig.3d**.

Trains of 5-30 kHz pulses are applied to drive amplifiers **7a** and **7b** alternately, with a small "off"-period during which no pulses are applied to either amplifier. The duration of each "off" period is dependent upon the original duty cycle of the clock timer **3**. The reason for the small "off" period in the driver waveforms is to prevent local corona arc as the phases change over each cycle.

The drive amplifiers **7a** and **7b** each use a BC182L transistor **10** (see **Fig.2**), small toroidal 2:1 pulse transformer **11** and a BUZ11 power-MOSFET **12** and apply pulse packets across the primary windings of their respective 25 kV line-output transformers **8a** and **8b** to produce an EHT ac voltage of high frequency at their secondary windings. The secondary windings are 'lifted' from system ground and provide, after simple half-wave rectification, the applied field for application to cell **20** (see **Fig.4**).

Cell **20** comprises a container **21** having walls **21a**, **21b** of electrically insulating material, e.g. a thermoplastics material, such as polymethyl methacrylate, typically spaced about 5 mm apart, and bipolar cell electrodes generally designated **22** and **23** and typically constructed from aluminium foil, positioned outside the walls **21a** and **21b**. Each bipolar cell electrode comprises a pair of electrode plates **22a** and **22b** (or **23a** and **23b**) for each side of the cell **20** separated from each other by an electrically insulating layer **24** (or **25**), e.g. of polycarbonate plastics material about 0.3 mm thick.

The electrode plates **22a** and **23a** form one set (set A) of electrode plates positioned on opposite sides of container **21** and the electrode plates **22b** and **23b** form another set of electrode plates positioned on opposite sides of the container **21**. An insulating layer **25**, e.g. of polycarbonate material, similar to the insulating layers **24a** or **24b** may be positioned between each bipolar cell electrode **22** (or **23**) and its adjacent container wall **21a**(or **21b**). A liquid electrolyte, preferably water, is placed in the container **21**.

In use, a train of positive pulses is applied to the electrode plates **22a** and **23b** and a train of negative pulses is applied to the electrode plates **23a** and **22b**. The timing of the pulses is shown schematically in **Fig.5**, which illustrates that, for set A (or for set B), whenever a positive pulse is applied to electrode plate **22a** (or **23b**), a negative pulse is also applied to electrode plate **23a** (or **22b**). However the pulses applied to the electrode plate set A are "out of phase" with the pulses applied to the electrode plate set B. In each train of pulses, the duration of each pulse is less than the gap between successive pulses.

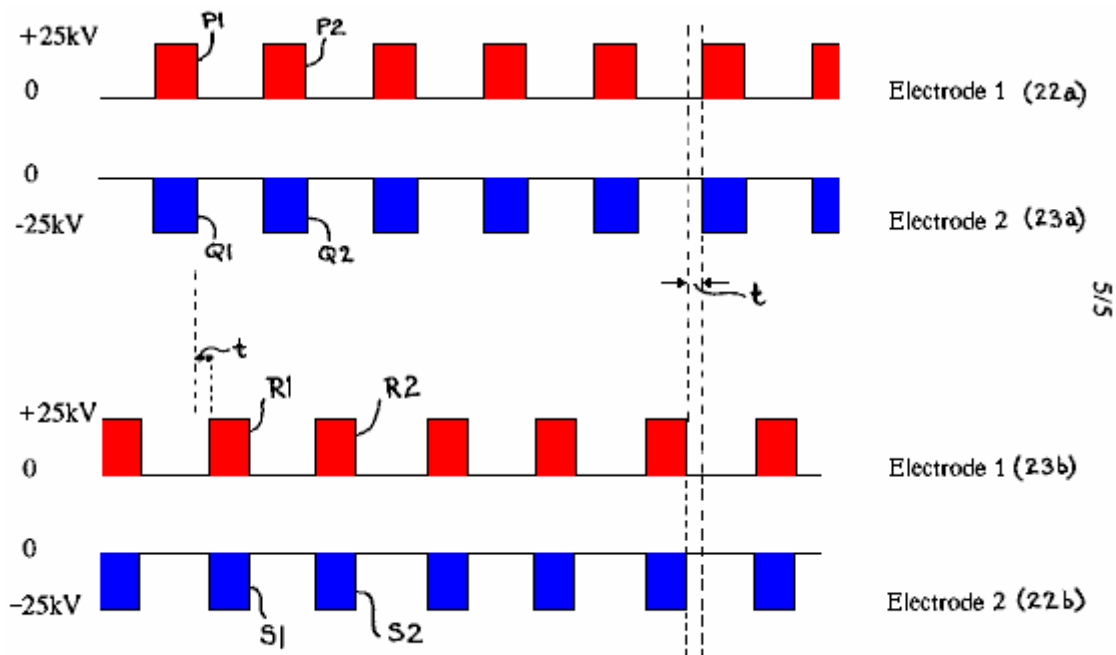

FIG. 5

By arranging for the pulses of electrode plate set B to be applied in the periods when no pulses are applied to the electrode plate set A, the situation arises where pairs of pulses are applied successively to the electrode plates of different sets of electrode plates, there being a short interval of time when no pulses are applied between each successive application of pulses to pairs of electrode plates. In other words, looking at **Fig.5**, pulses **P1** and **Q1** are applied at the same time to the electrode plates **22a** and **23a**. The pulses **P1** and **Q1** are of the same pulse length and, at the end of their duration, there is a short time period **t** before pulses **R1** and **S1** are applied to the electrode plates **23b** and **22b**.

The pulses **R1** and **S1** are of the same pulse length as the pulses **P1** and **Q1** and, at the end of their duration, there is a further time **t** before the next pulses **P2** and **Q2** are applied to the electrode plates **22a** and **23a**. It will be appreciated that whenever a pulse of one sign is applied to one of the electrode plates of a set, a pulse of the opposite sign is applied to the other electrode plate of that set.

Furthermore, by switching from one to the other electrode plate set the polarities applied across the container are repeatedly switched resulting in an "alternating" electric field being created across the "liquid dielectric" water in the container.

The Electrolyser of Spiro Spiros

Patent WO 9528510

26th October 1995

Inventor: Spiro Ross Spiros

IMPROVEMENTS IN ELECTROLYSIS SYSTEMS & THE AVAILABILITY OF OVER-UNITY ENERGY

This patent application shows the details of an electrolyser system which it is claimed, produces greater output than the input power needed to operate it.

ABSTRACT

A looped energy system for the generation of excess energy available to do work is disclosed. The system comprises an electrolysis cell unit **150** receiving a supply of water to liberate separated hydrogen gas **154** and oxygen **156** by electrolysis driven by a DC voltage **152** applied across respective anodes and cathodes of the cell unit **150**. A hydrogen gas receiver **158** receives and stores hydrogen gas liberated by the cell unit **150**, and an oxygen gas receiver **160** receives and stores oxygen gas liberated by the cell unit **150**. A gas expansion device **162** expands the stored gases to recover expansion work, and a gas combustion device **168** mixes and combusts the expanded hydrogen gas and oxygen gas to recover combusted work. A proportion of the sum of the expansion work and the combustion work sustains electrolysis of the cell unit to retain operational gas pressure in the gas receivers **158**, **160** such that the energy system is self-sustaining, and there is excess energy available from the sum of energies.

TECHNICAL FIELD OF THE INVENTION

The present invention relates to the generation of hydrogen gas and oxygen gas from water, either as an admixture or as separated gases, by the process of electrolysis, and relates further to applications for the use of the liberated gas. Embodiments of the invention relate particularly to apparatus for the efficient generation of these gases, and to use of the gases in an internal combustion engine and an implosion pump. The invention also discloses a closed-loop energy generation system where latent molecular energy is liberated as a form of 'free energy' so the system can be self-sustaining.

Reference is made to commonly-owned International patent application No. PCT/AU94/000532, having the International filing date of 6 September 1994.

Background Art

The technique of electrolysing water in the presence of an electrolyte such as sodium hydroxide (NaOH) or potassium hydroxide (KOH) to liberate hydrogen and oxygen gas (H₂, O₂) is well known. The process involves applying a DC potential difference between two or more anode/cathode electrode pairs and delivering the minimum energy required to break the H-O bonds (i.e. 68.3 kcal per mole @ STP).

The gases are produced in the stoichiometric proportions for O₂:H₂ of 1:2 liberated respectively from the anode (+) and cathode (-).

Reference can be made to the following texts:

"Modern Electrochemistry, Volume 2, John O'M. Bockris and Amulya K.N. Reddy, Plenum Publishing Corporation",

"Electro-Chemical Science, J. O'M. Bockris and D.M. Drazic, Taylor and Francis Limited" and

"Fuel Cells, Their Electrochemistry, J. O'M. Bockris and S. Srinivasan, McGraw-Hill Book Company".

A discussion of experimental work in relation to electrolysis processes can be obtained from "Hydrogen Energy, Part A, Hydrogen Economy Miami Energy Conference, Miami Beach, Florida, 1974, edited by T. Nejat Veziroglu, Plenum Press". The papers presented by J. O'M. Bockris on pages 371 to 379, by F.C. Jensen and F.H. Schubert on pages 425 to 439 and by John B. Pangborn and John C. Sharer on pages 499 to 508 are of particular relevance.

On a macro-scale, the amount of gas produced depends upon a number of variables, including the type and concentration of the electrolytic solution used, the anode/cathode electrode pair surface area, the electrolytic resistance (equating to ionic conductivity, which is a function of temperature and pressure), achievable current density and anode/cathode potential difference. The total energy delivered must be sufficient to disassociate the

water ions to generate hydrogen and oxygen gases, yet avoid plating (oxidation/reduction) of the metallic or conductive non-metallic materials from which the electrodes are constructed.

DISCLOSURE OF THE INVENTION

The invention discloses a looped-energy system for the generation of excess energy available to do work, the said system comprising of:

An electrolysis cell unit receiving a supply of water for liberating separated hydrogen gas and oxygen gas by electrolysis due to a DC voltage applied across respective anodes and cathodes of the cell;

A hydrogen gas receiver to receive and store the hydrogen gas liberated by the electrolysis cell;

An oxygen gas receiver to receive and store the oxygen gas liberated by the electrolysis cell;

A gas-expansion chamber to allow the expansion of the stored gases to recover expansion work; and

A gas-combustion mechanism for mixing and combusting the expanded hydrogen and oxygen gases to recover combustion work; and wherein a proportion of the sum of the expansion work and the combustion work sustains the electrolysis of the electrolysis cell in order to retain the operational gas pressure in the hydrogen and oxygen gas receivers so that the energy system is self-sustaining and there is excess energy available.

The invention further discloses a method for the generation of excess energy available to do work by the process of electrolysis, said method comprising the steps of: electrolysing water by a DC voltage to liberate separated hydrogen gas and oxygen gas; separately receiving and storing the hydrogen and oxygen gases in a manner to be self-pressuring; separately expanding the stored gas to recover expansion energy; burning the expanded gases to recover combustion energy; and applying a portion of the sum of the expansion work and the combustion work as the DC voltage to retain operational gas pressures and sustain the electrolysis, there being excess energy available to do this.

The invention also discloses an internal combustion engine powered by hydrogen and oxygen comprising of:

At least one cylinder and

At least one reciprocating piston within the cylinder;

A hydrogen gas input port in communication with the cylinder for receiving a supply of pressurised hydrogen;

An oxygen gas input port in communication with the cylinder for receiving a supply of pressurised oxygen; and

An exhaust port in communication with the cylinder and wherein the engine can be operated in a two-stroke manner whereby, at the top of the stroke, hydrogen gas is supplied through the respective inlet port to the cylinder driving the piston downwards, oxygen gas then is supplied through the respective inlet port to the cylinder to drive the cylinder further downwards, after which time self-detonation occurs and the piston moves to the bottom of the stroke and upwards again with the exhaust port opened to force out the water vapour resulting from the detonation.

The invention also discloses an implosion pump comprising of;

A combustion chamber interposed, and in communication with,

An upper reservoir and a lower reservoir separated by a vertical distance across which water is to be pumped, this chamber receiving admixed hydrogen and oxygen at a pressure sufficient to lift a volume of water the distance from there to the top reservoir, the gas in the chamber then being ignited to create a vacuum in the chamber to draw water from the lower reservoir to fill the chamber, whereupon a pumping cycle is established and can be repeated.

The invention also discloses a parallel stacked arrangement of cell plates for a water electrolysis unit, the cell plates alternately forming an anode and cathode of the electrolysis unit, and the arrangement including separate

hydrogen gas and oxygen gas outlet ports respectively linked to the anode cell plates and the cathode cell plates and extending longitudinally along the plate stack. These outlet ports are arranged so as to be insulated from the anode and cathode plates.

DESCRIPTION OF THE DRAWINGS

Figs.1 1a-16 of noted International application no. PCT/AU94/000532 are reproduced to aid description of the present invention, but herein denoted as Figs.1a-6:

Fig.1A and **Fig.1B** show an embodiment of a cell plate:

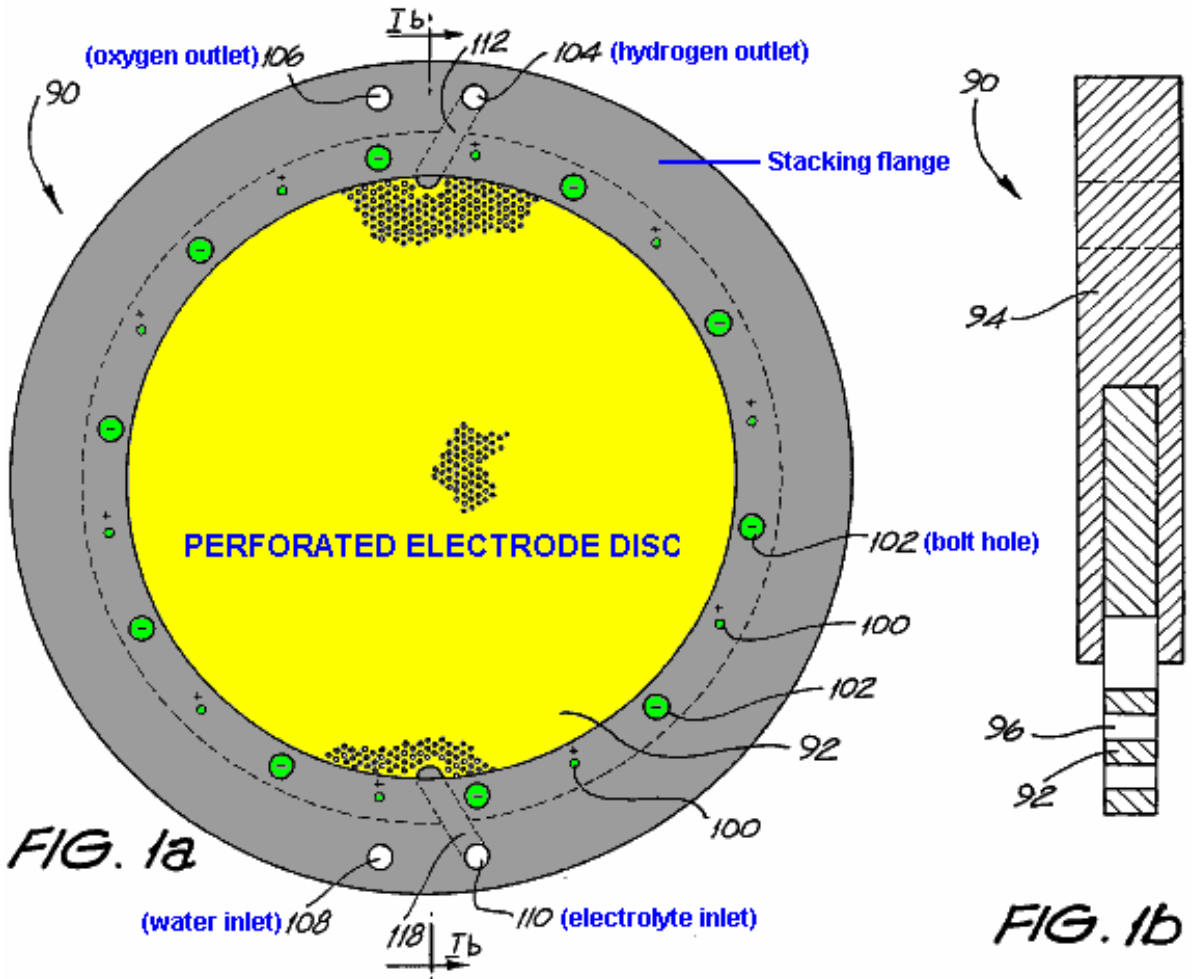

Fig.2A and **Fig.2B** show a complementary cell plate to that of Fig.1A and Fig.1B:

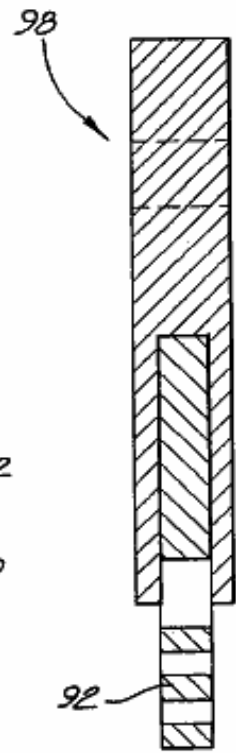
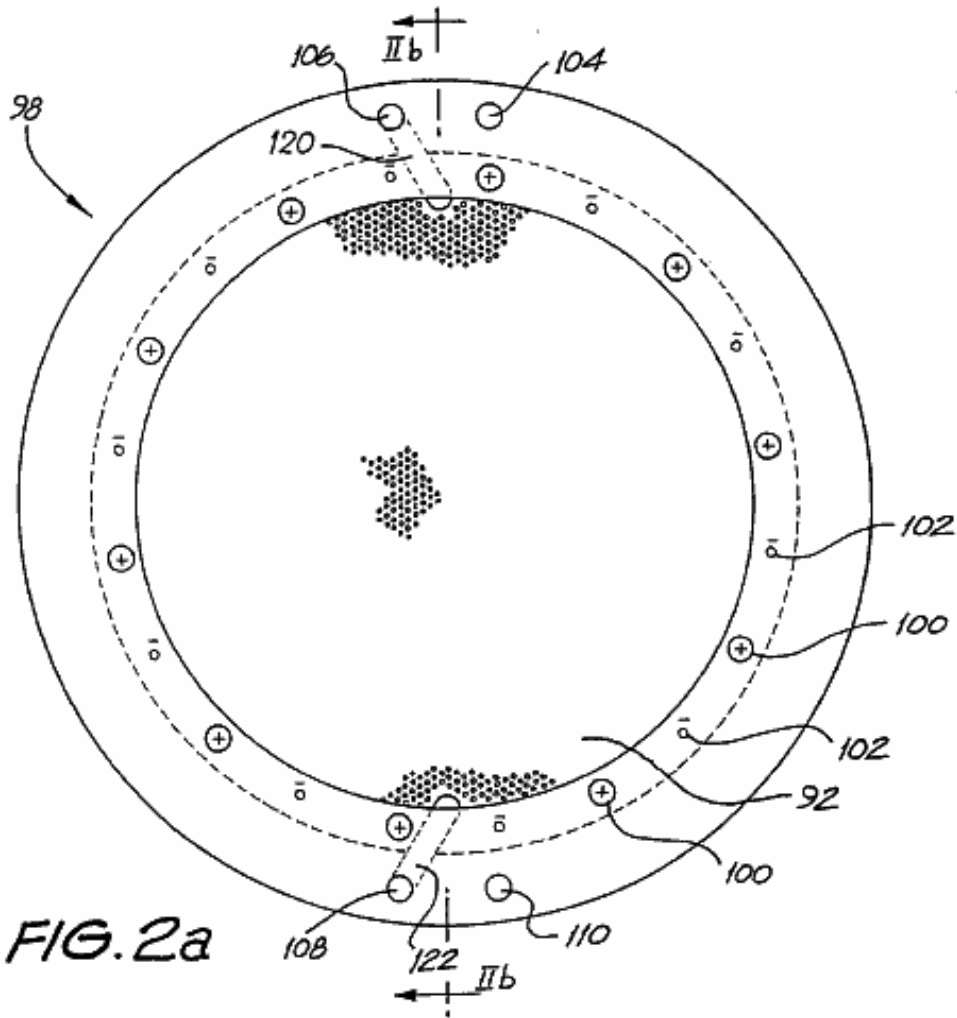

Fig.3 shows detail of the perforations and porting of the cell plates of Figs. 1A,1B, 2A and 2B:

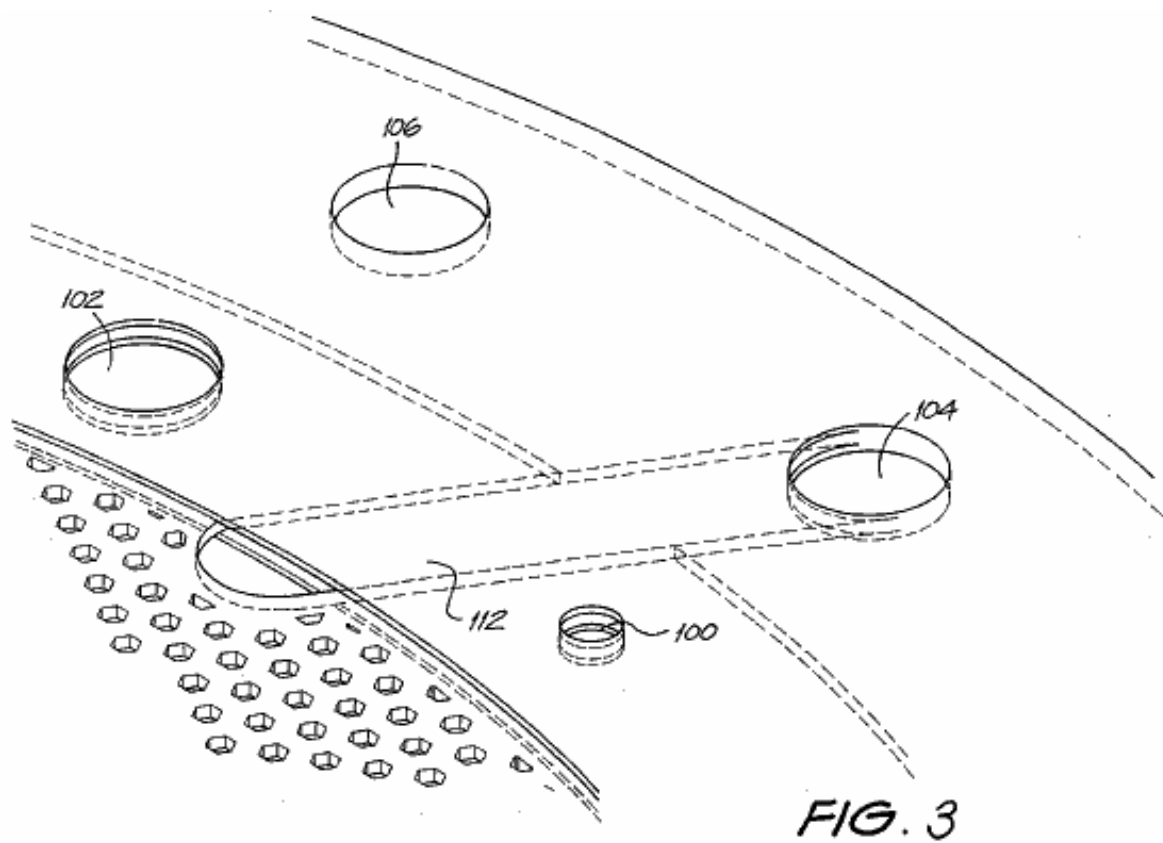

Fig.4 shows an exploded stacked arrangement of the cell plates of Figs. 1A,1B, 2A and 2B:

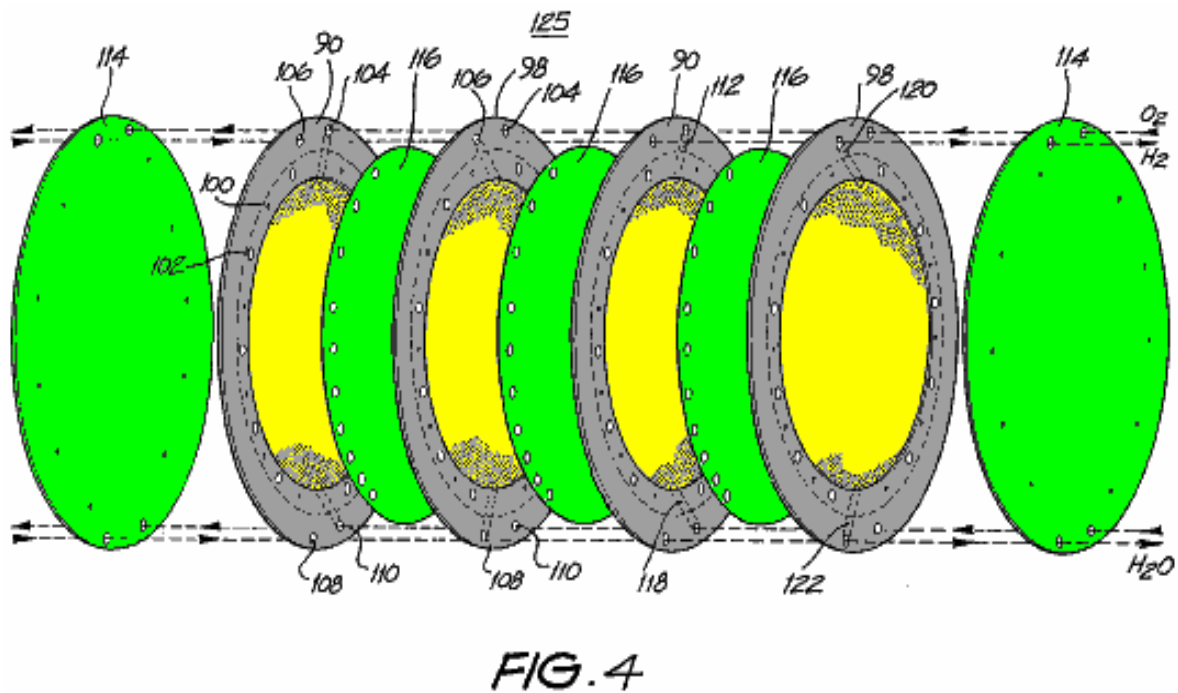

Fig.5A shows a schematic view of the gas separation system of Fig.4:

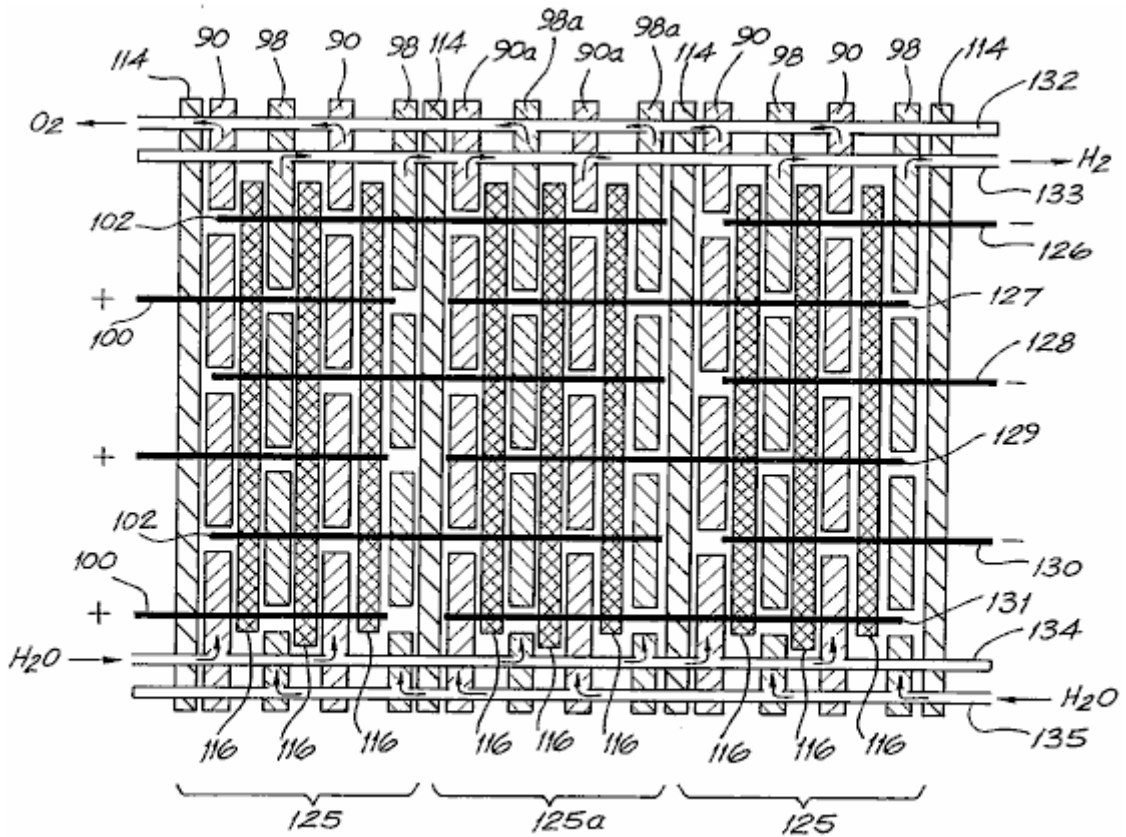

FIG. 5a

Fig.5B shows a stylised representation of Fig.5a:

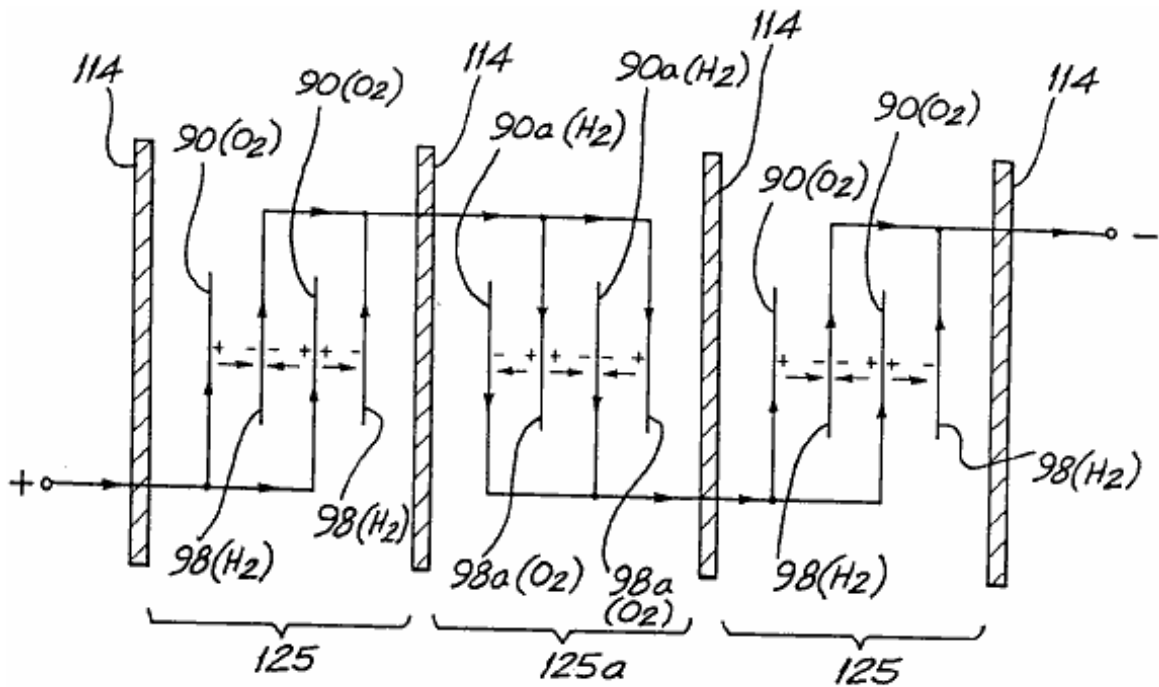

FIG. 5b

Fig.5C shows an electrical equivalent circuit of Fig.5A and

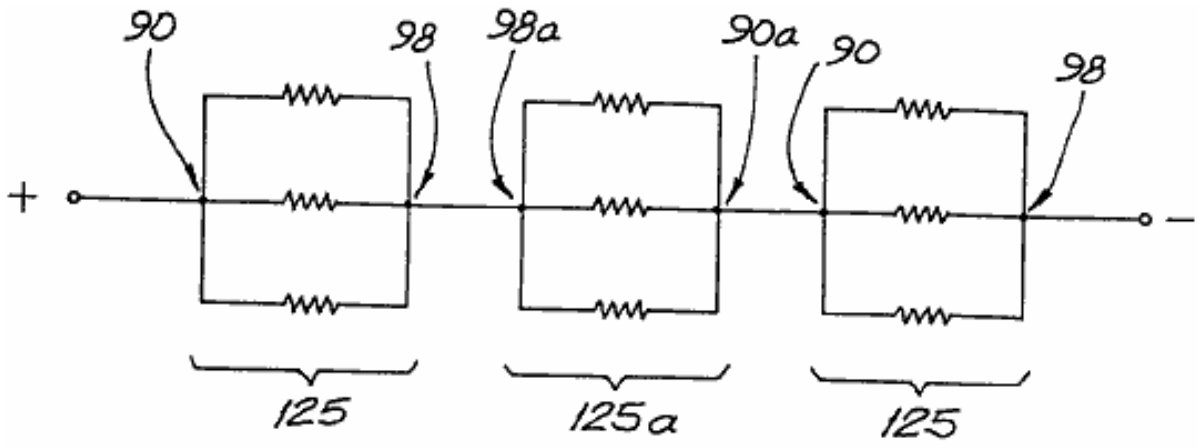

FIG. 5c

Fig.6 shows a gas collection system for use with the cell bank separation system of Figs. 4 and 5a.

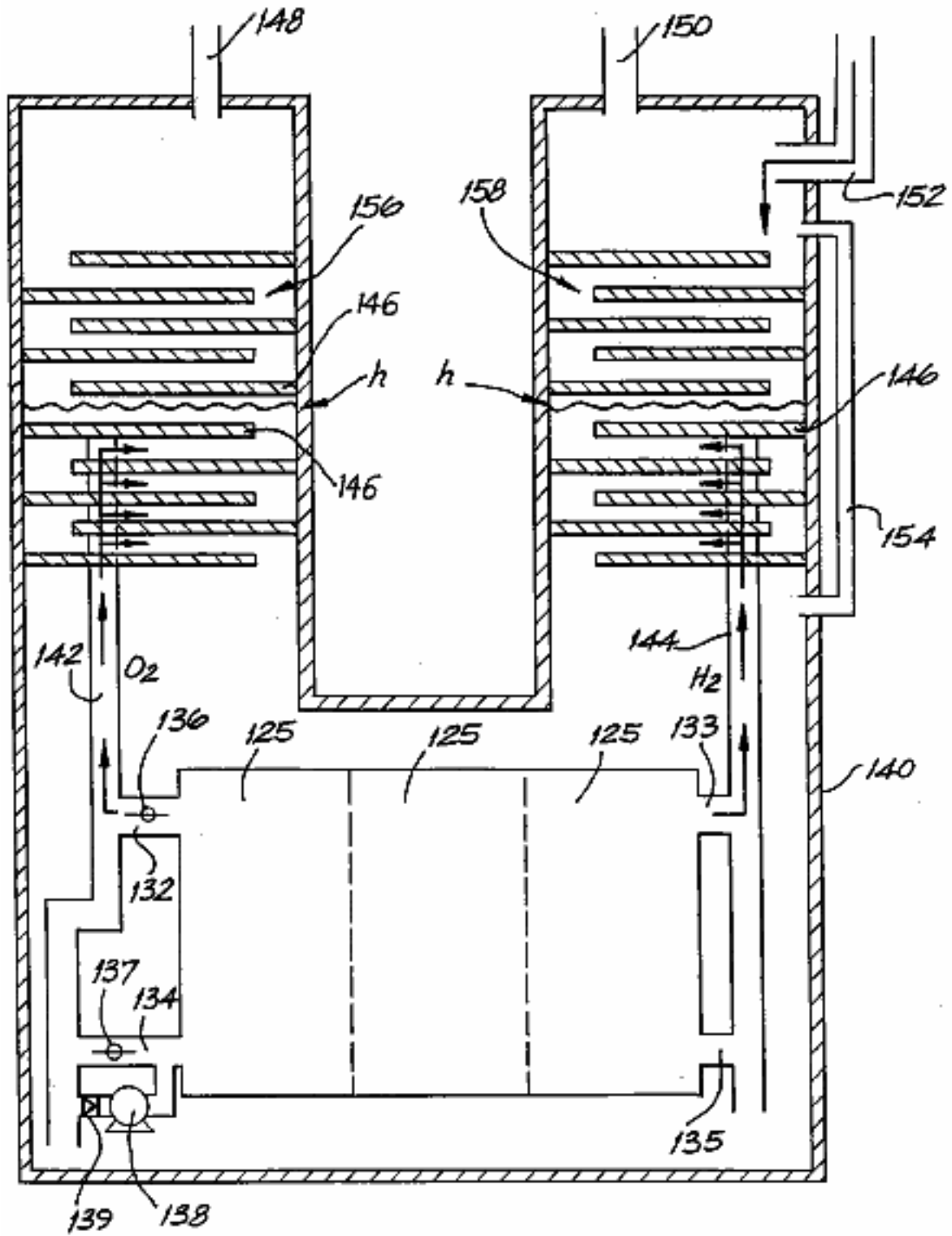

FIG. 6

The remaining drawings are:
Fig.7A and Fig.7B are views of a first cell plate:

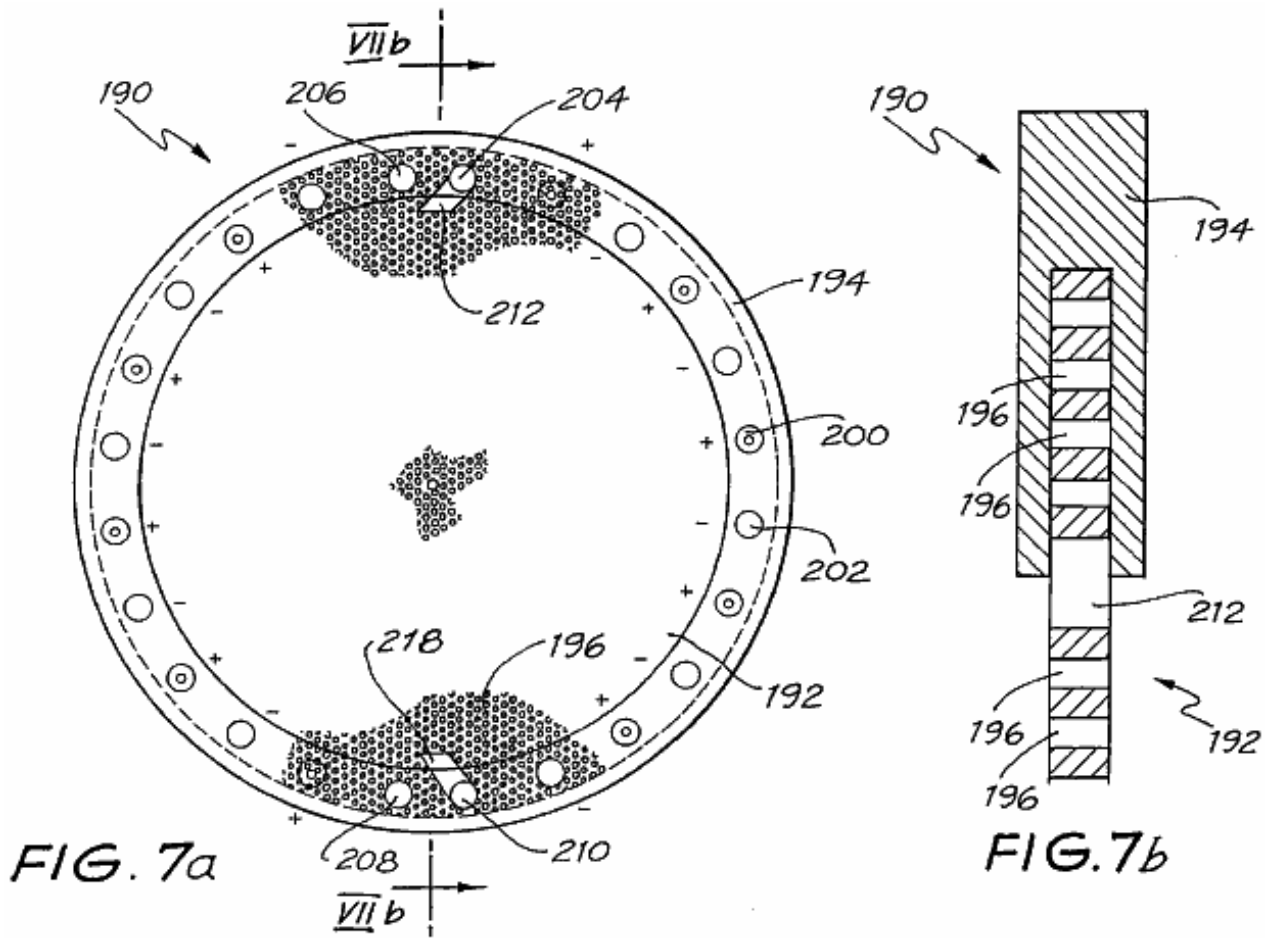

Fig.8A and Fig.8B are views of a second cell plate:

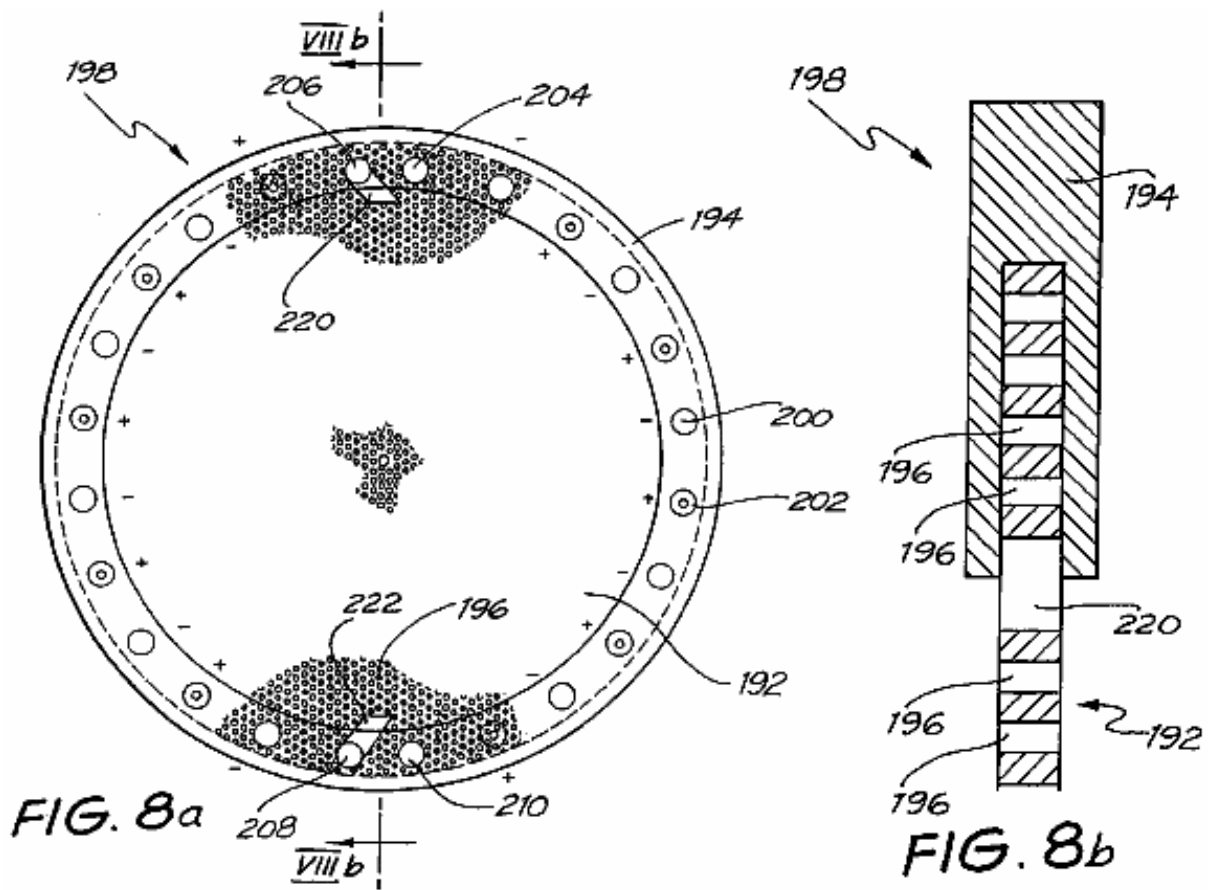

Fig.9 shows detail of the edge margin of the first cell plate:

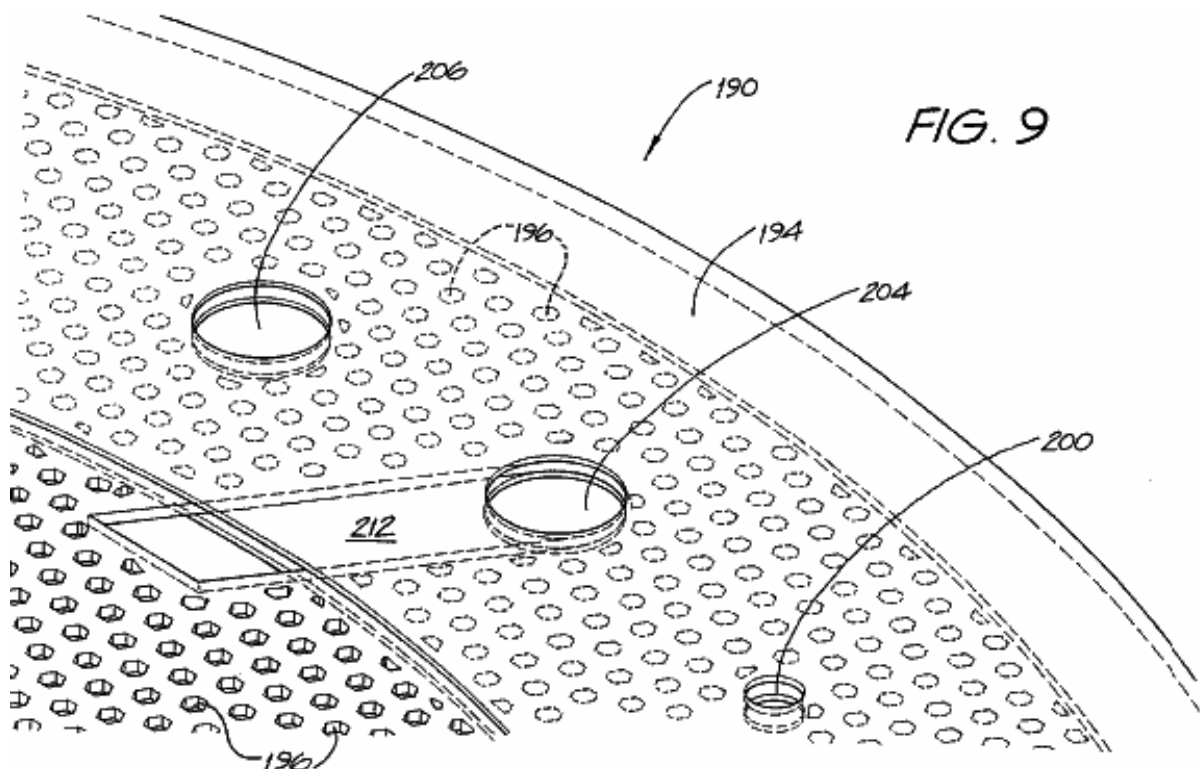

Fig.10 shows an exploded stacked arrangement of the cell plates shown in Fig.7A and Fig.8A:

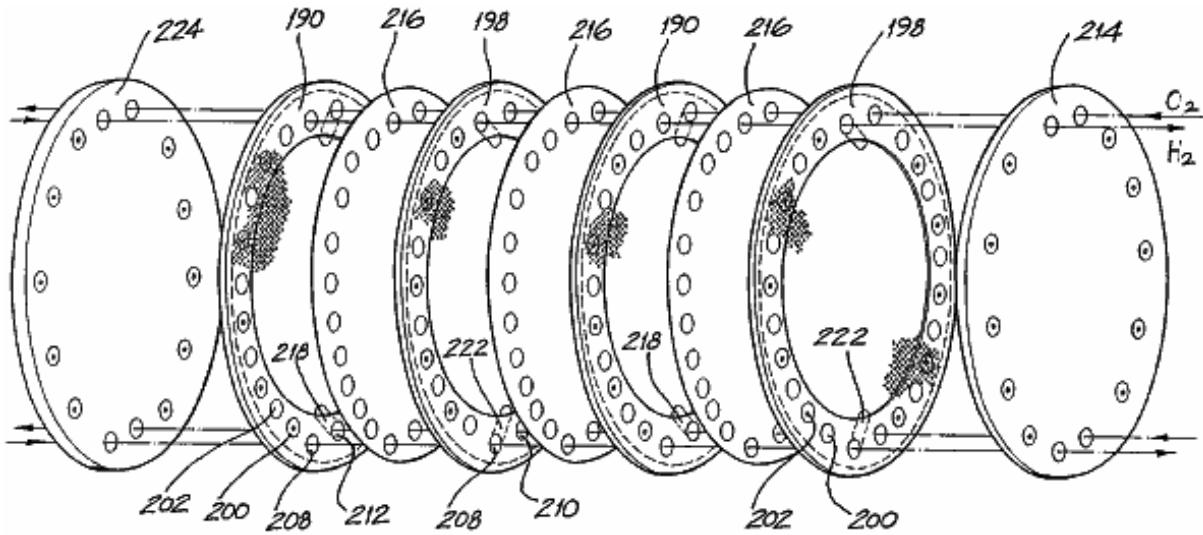

FIG. 10

Fig.11 is a cross-sectional view of three of the stacked cell plates shown in Fig.10 in the vicinity of a gas port:

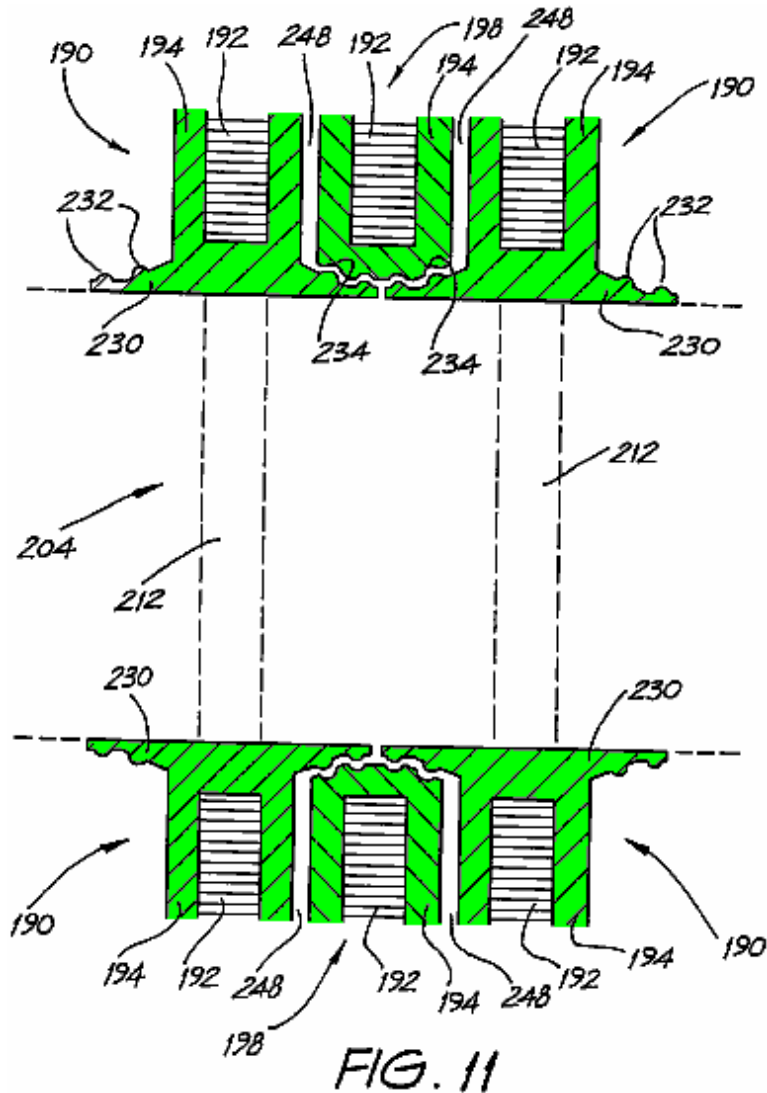

FIG. 11

Fig.12A and Fig.12B respectively show detail of the first and second cell plates in the vicinity of a gas port:

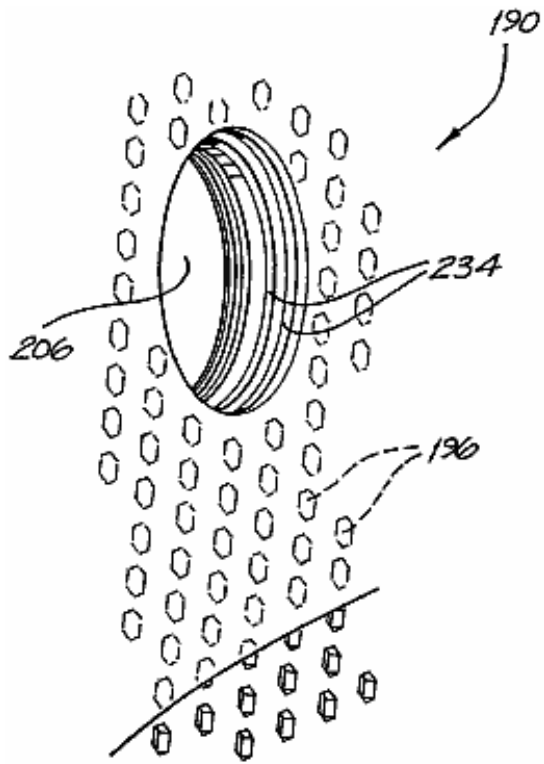

FIG. 12a

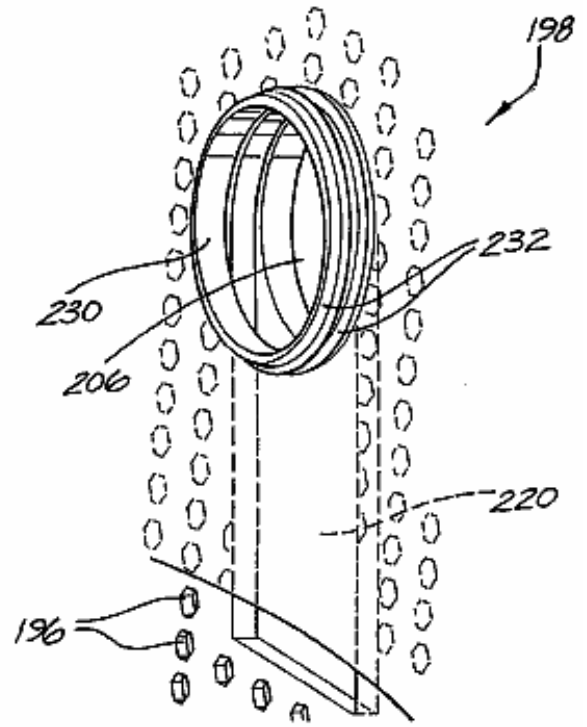

FIG. 12b

Fig.13 is a cross-sectional view of a cell unit of four stacked cell plates in the vicinity of an interconnecting shaft:

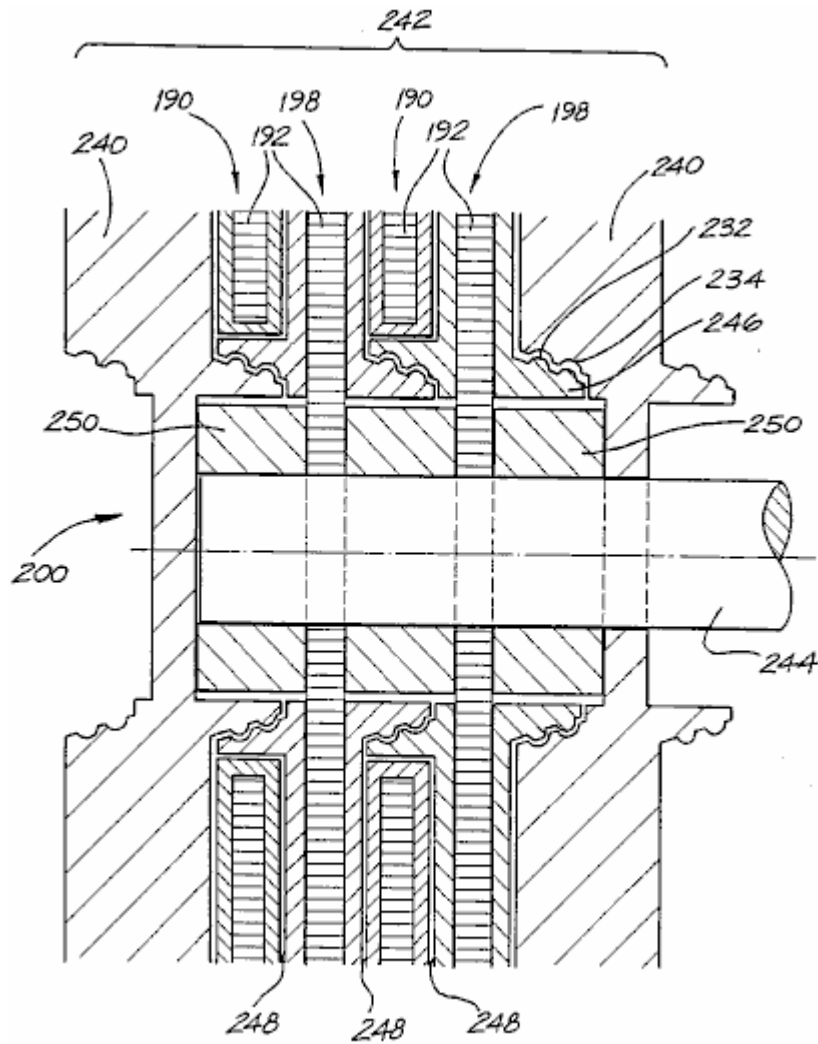

FIG. 13

Fig.14 shows a perspective view of a locking nut used in the arrangement of Fig.13:

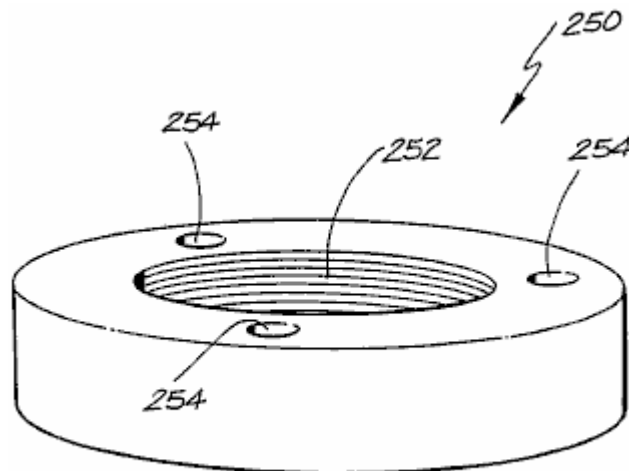
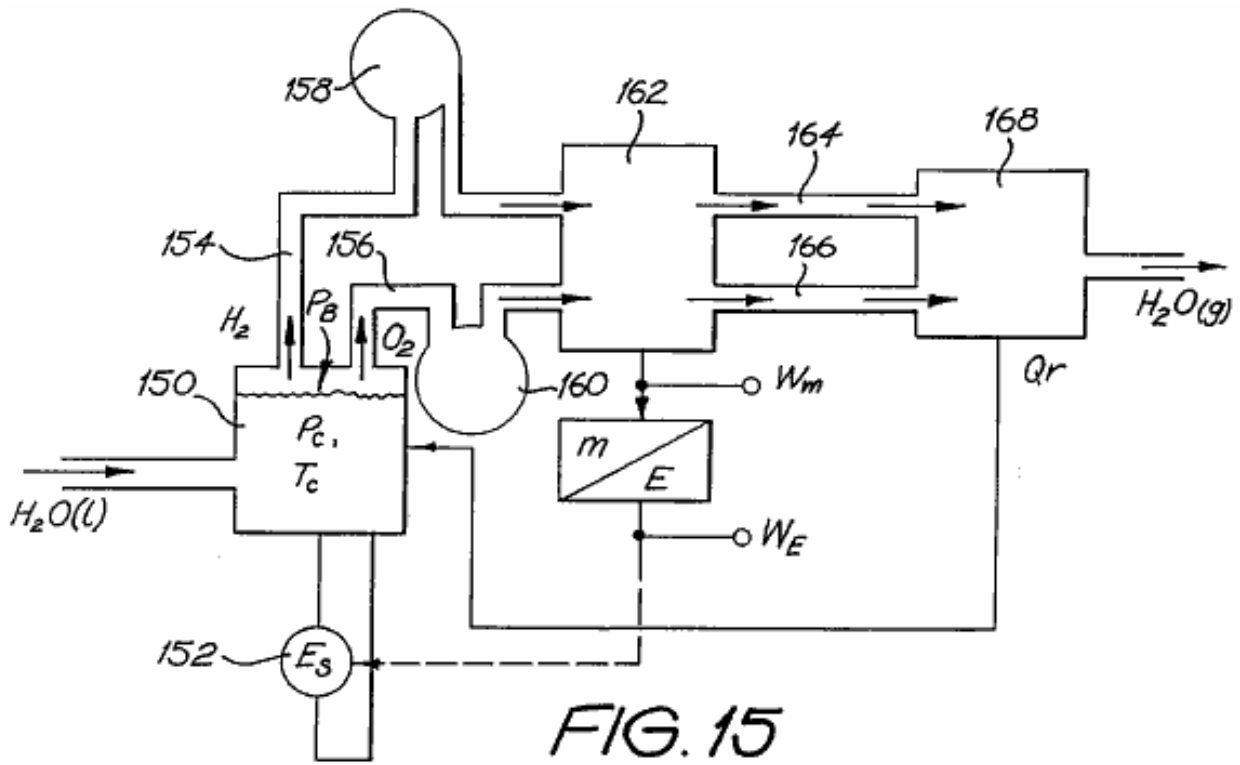

FIG. 14

Fig.15 shows an idealised electrolysis system:



Figs.16-30 are graphs supporting the system of Fig.15 and the availability of over-unity energy:

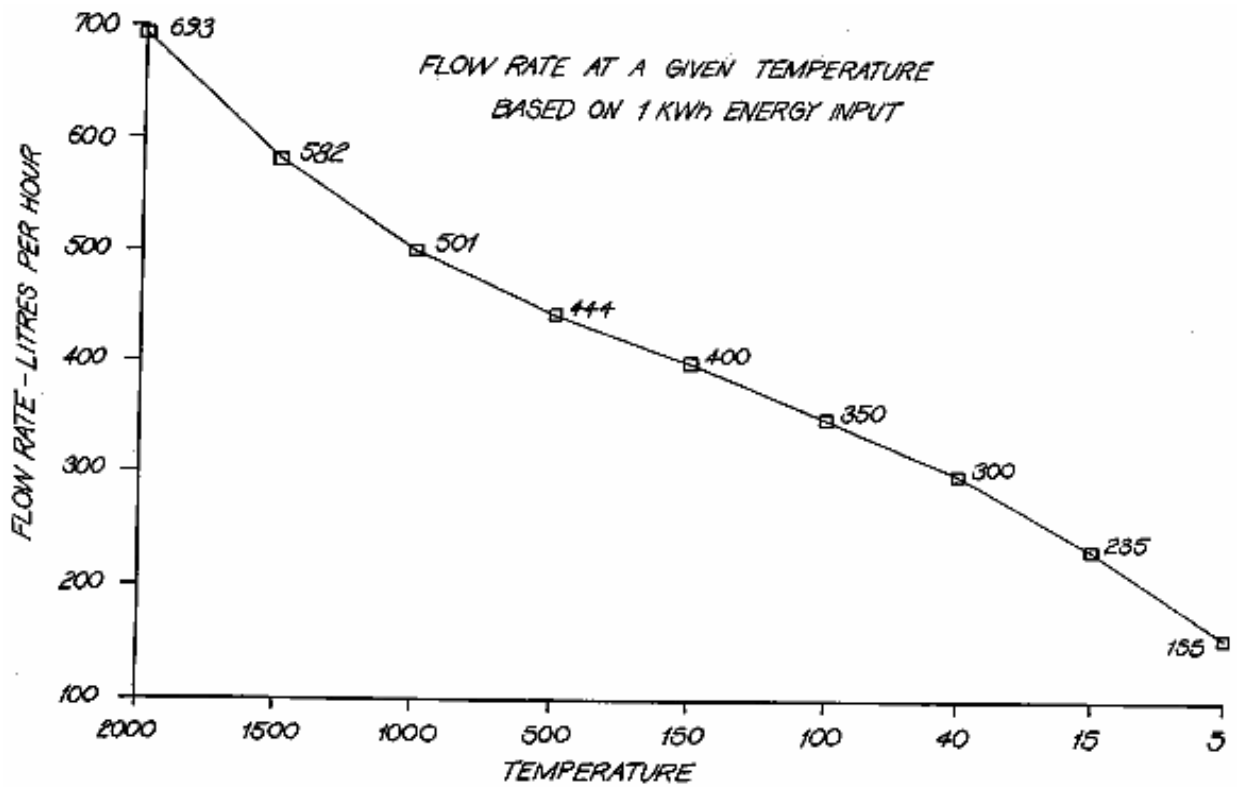

FIG. 16

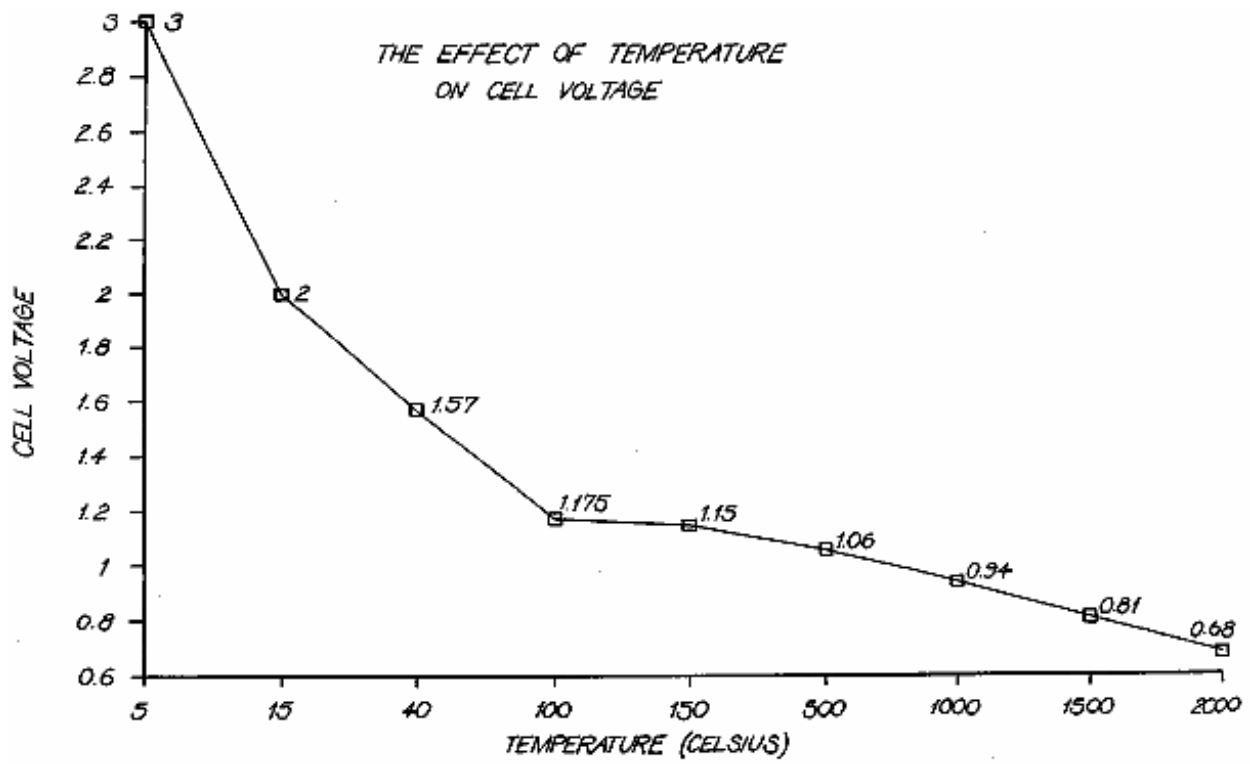

FIG. 17

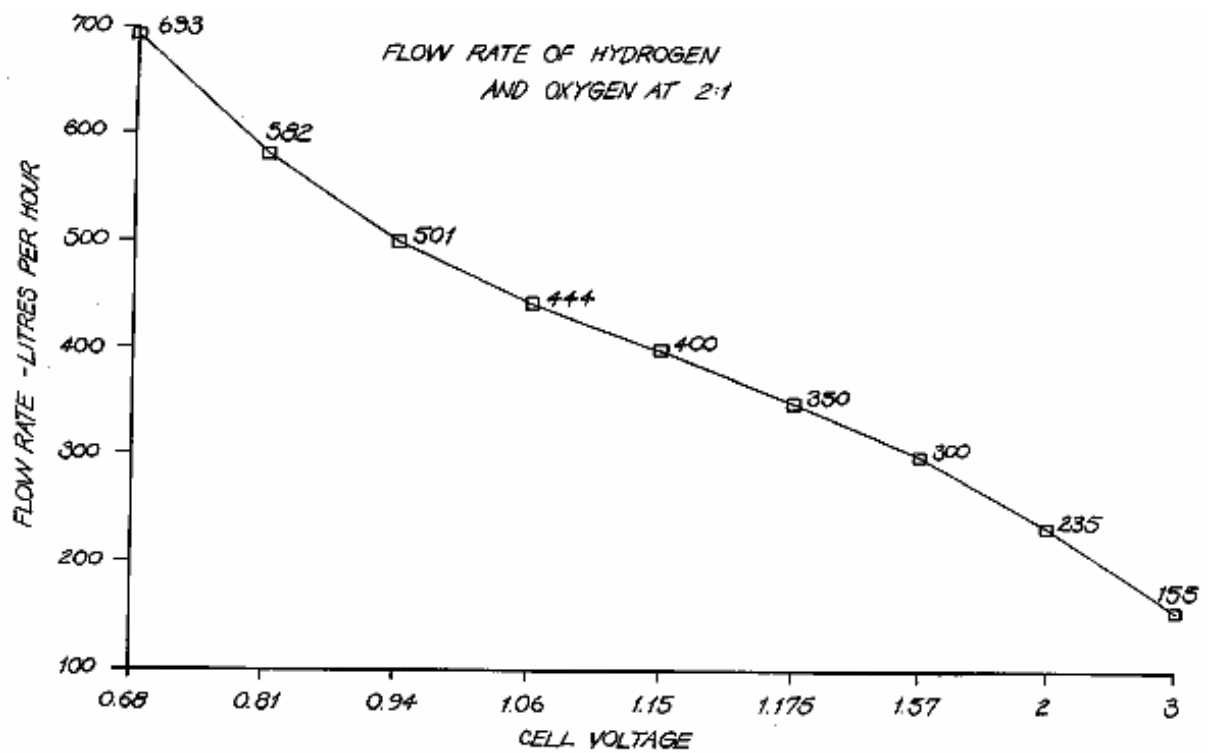

FIG. 18

TEST RUN	AMPS	VOLTS	TEMP C° (INITIAL)	TEMP C° (FINAL)	TIME (SECS.)	WATTS (A·V)	PRESSURE (psi)	FLOW RATE (lph)
1	47.2	38.5	40	-	-	1817.2	1 ATMOSPHER.	-
2	54.3	34.4	-	70	222.13	1867.9	1 ATMOSPHER.	89
3	65.2	34.4	40	70	26.37	2242.9	100-170	95
4	65.6	29.1	40	70	20.47	1909.0	300-410	97
5	62.9	29.4	40	70	22.93	1849.3	500-610	97
6	64.7	29.4	40	70	24.19	1902.2	700-850	98
7	63.9	29.2	40	70	24.13	1865.9	900-1050	98
8	64.0	29.3	40	70	22.37	1875.2	1100-1250	98
9	64.4	29.3	40	70	21.83	1886.9	1300-1450	98
10	63.7	29.1	40	70	23.34	1853.7	1500-1660	99
11	62.7	29.7	40	70	12.76	1862.2	1700-1890	100
12	61.9	29.9	40	70	11.17	1850.8	1900-1990	-
13	61.7	30.0	40	70	11.19	1851.0	2090-2170	-
14	60.7	30.6	40	70	15.71	1857.4	2290-2400	-
15	66.6	29.9	40	70	-	1991.3	2280-2420	-
16	61.7	30.0	45	70	-	1851.0	2270-2390	-
17	62.5	30.0	57	70	-	1875.0	2350-2380	-
18	62.0	30.1	59	70	-	1866.2	2350-2390	-
19	62.9	29.9	-	-	-	1880.7	2400-2420	-
20	63.0	29.4	-	-	-	1852.2	2430-2450	-

FIG. 19

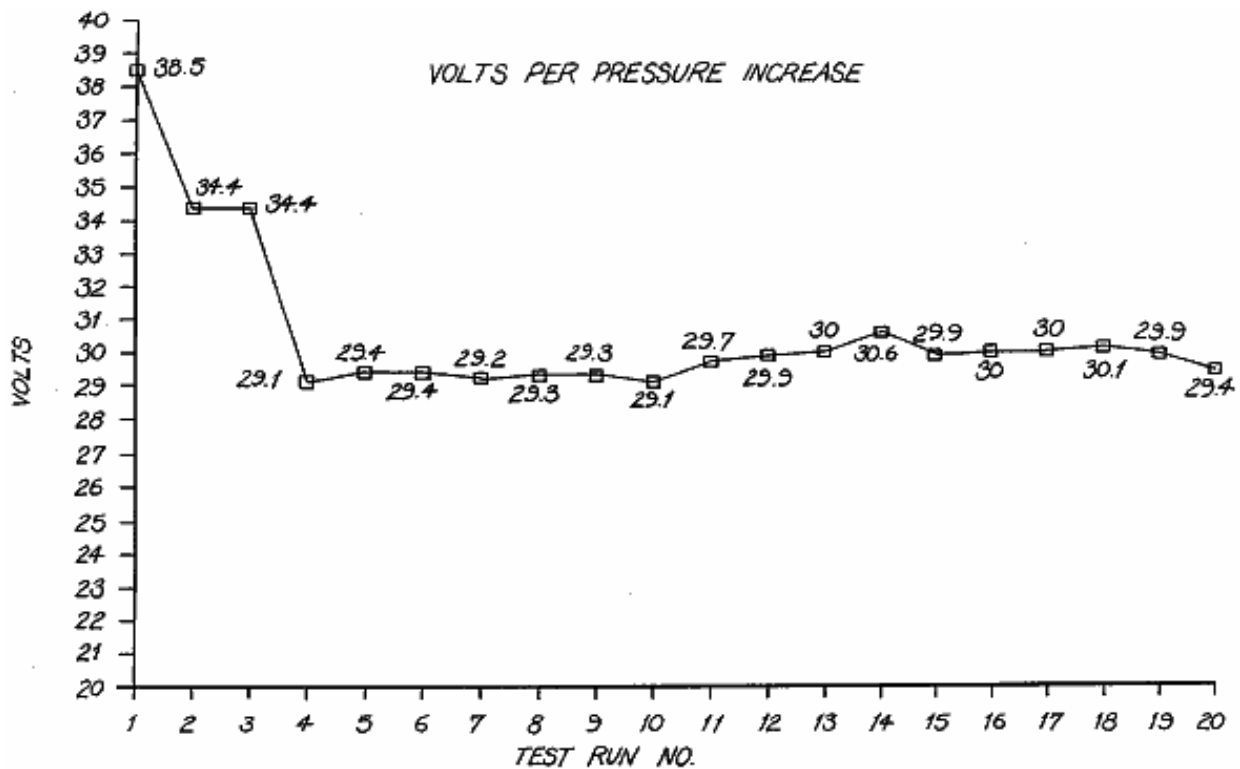

FIG. 20

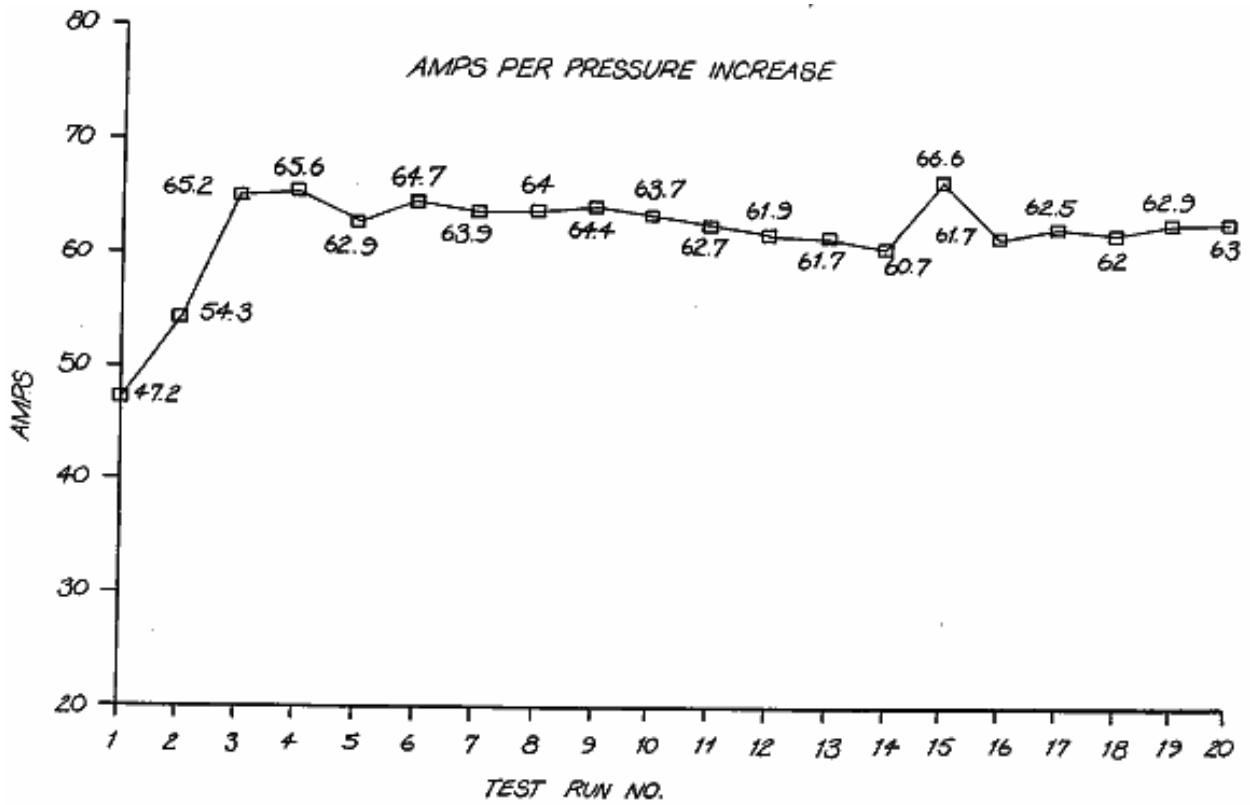

FIG.21

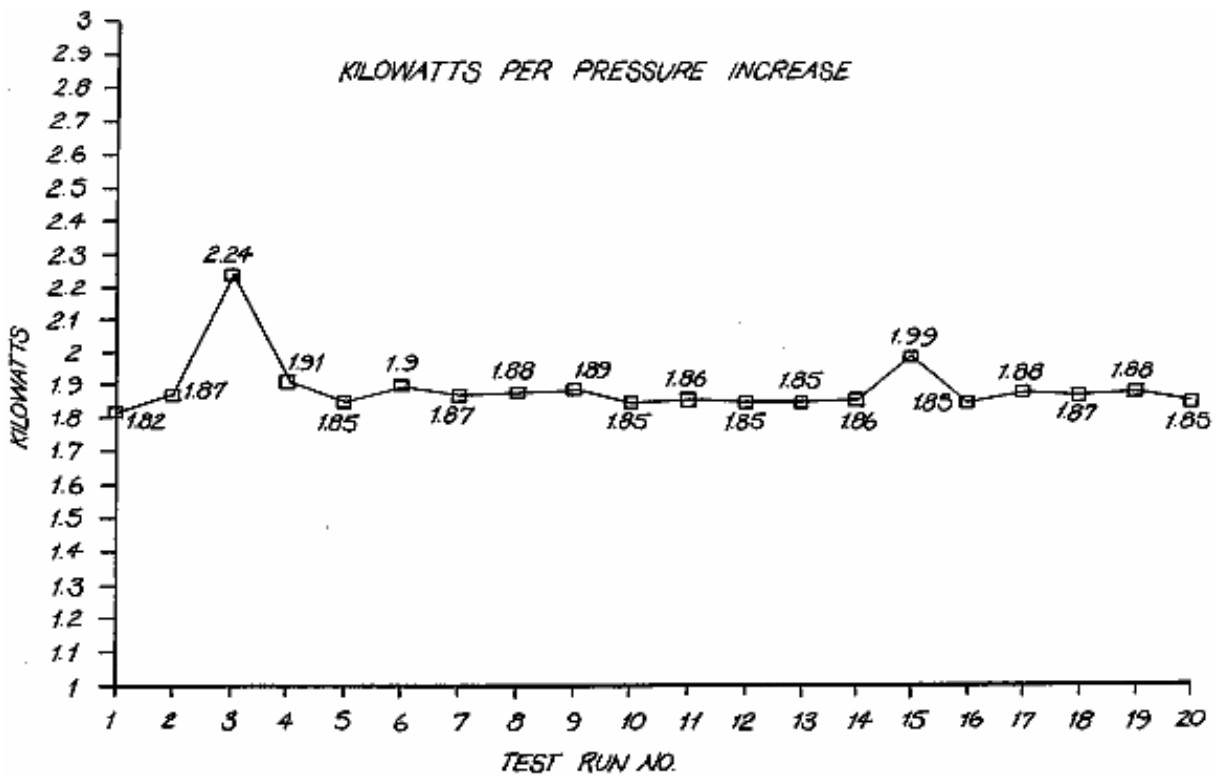

FIG.22

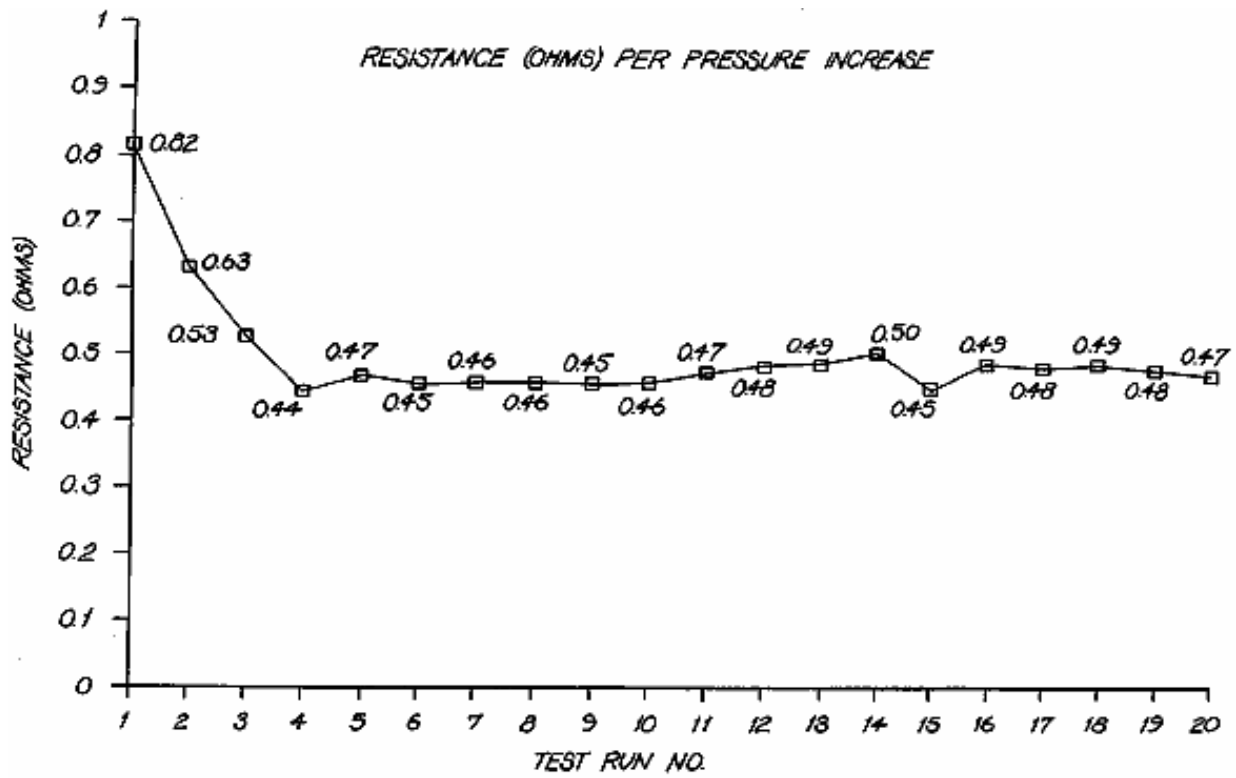

FIG.23

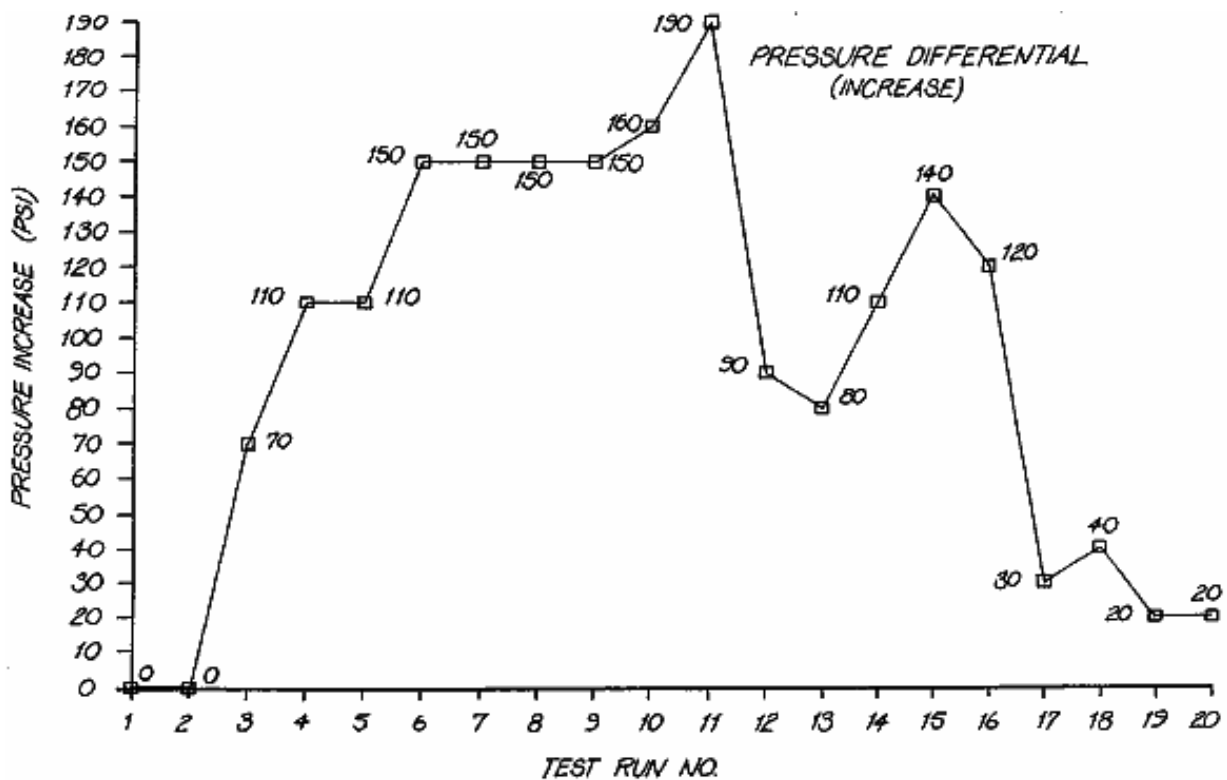

FIG.24

FLOW RATE ANALYSIS PER PRESSURE INCREASE

RUN	VOLTS	AMPS	TEMP C°	TIME-SECS	VOLUME (LITRES)	LPH	PRESSURE PSI
1	27.5	49.7	70	114.0	2.8	88	14.7
2	34.4	54.3	70	222.13	5.49	89	14.7
3	20.5	51.9	87	190.0	4.7	89	50
4	20	55	80	33.0	1.0	109	170
5	34.4	65.2	70	26.37	0.69	95	200
6	29.1	65.6	70	20.47	0.55	97	410
7	29.4	62.9	70	22.93	0.62	97	610
8	29.4	64.7	70	24.19	0.66	98	850
9	29.2	63.9	70	24.13	0.66	98	1050
10	29.3	64.0	70	22.37	0.61	98	1250
11	29.3	64.4	70	21.83	0.59	98	1450
12	29.1	63.7	70	23.34	0.64	99	1660
13	29.7	62.7	70	12.76	0.35	100	1890

FIG. 25

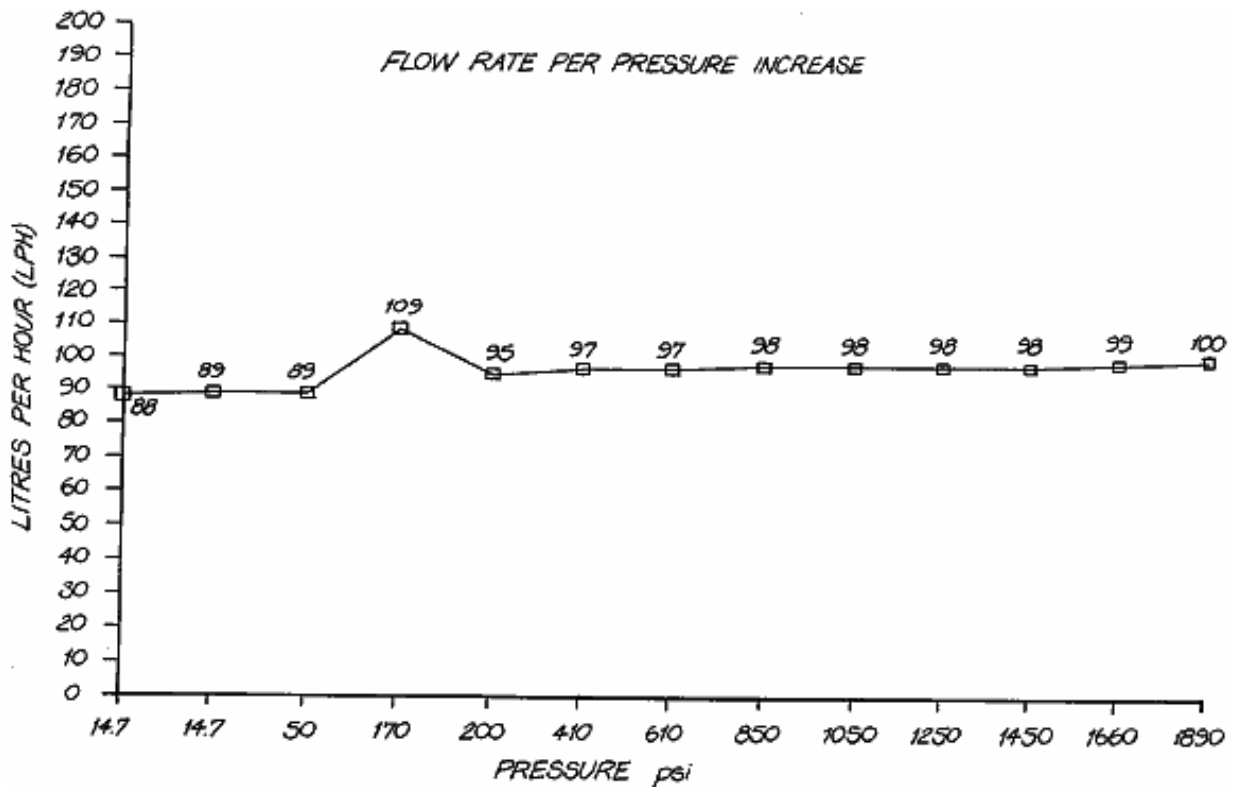

FIG. 26

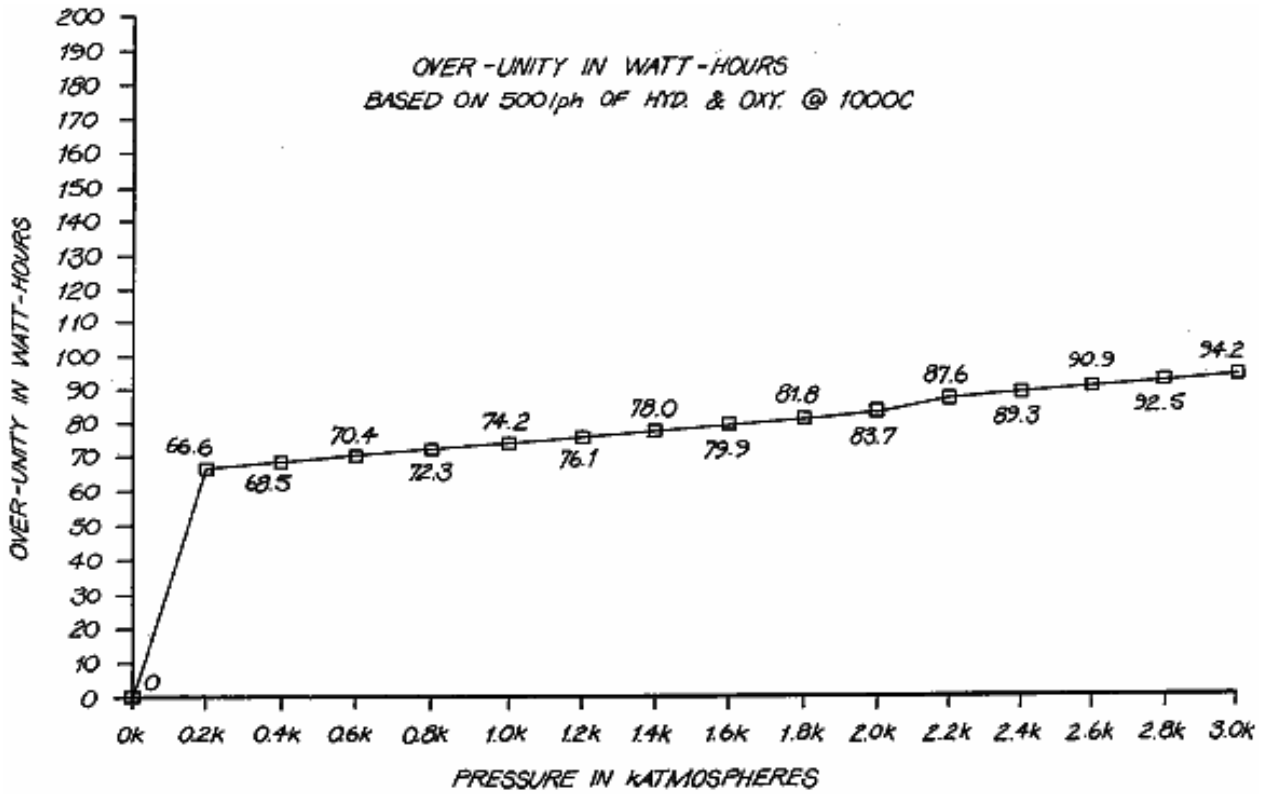

FIG. 27

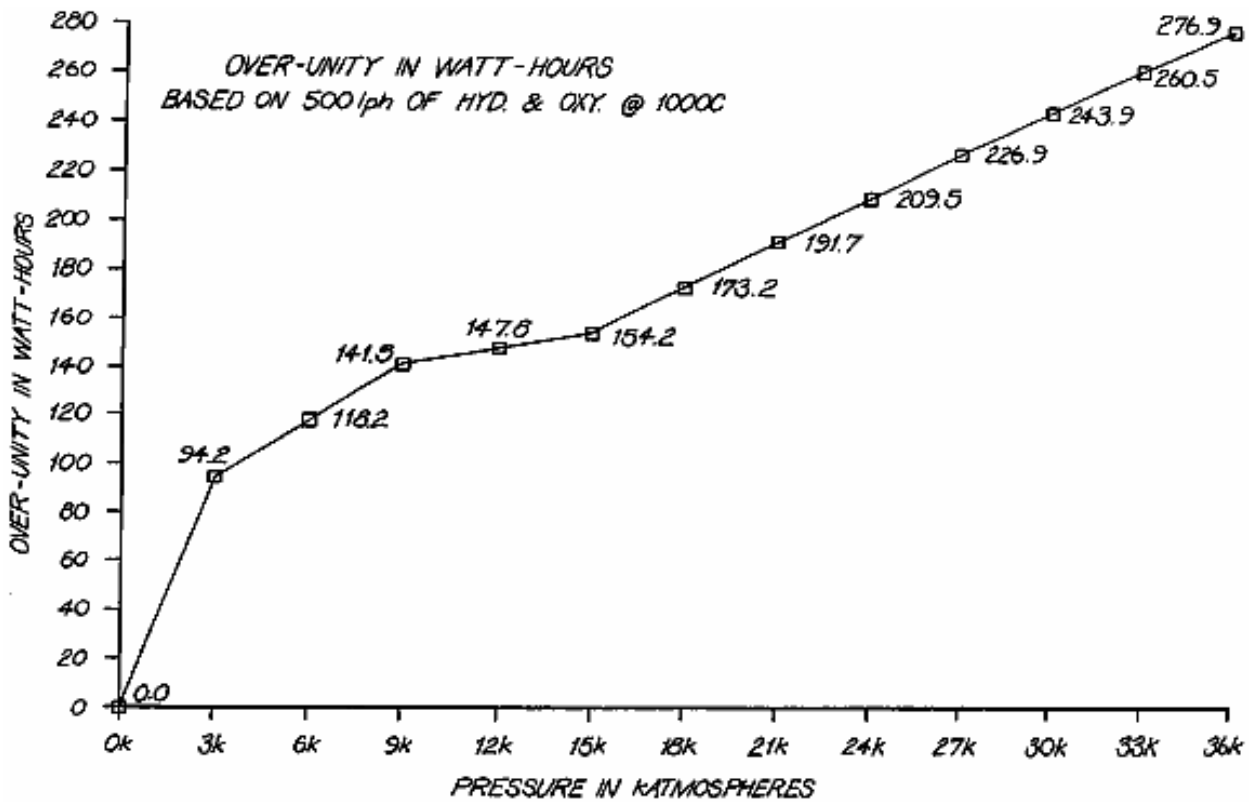

FIG. 28

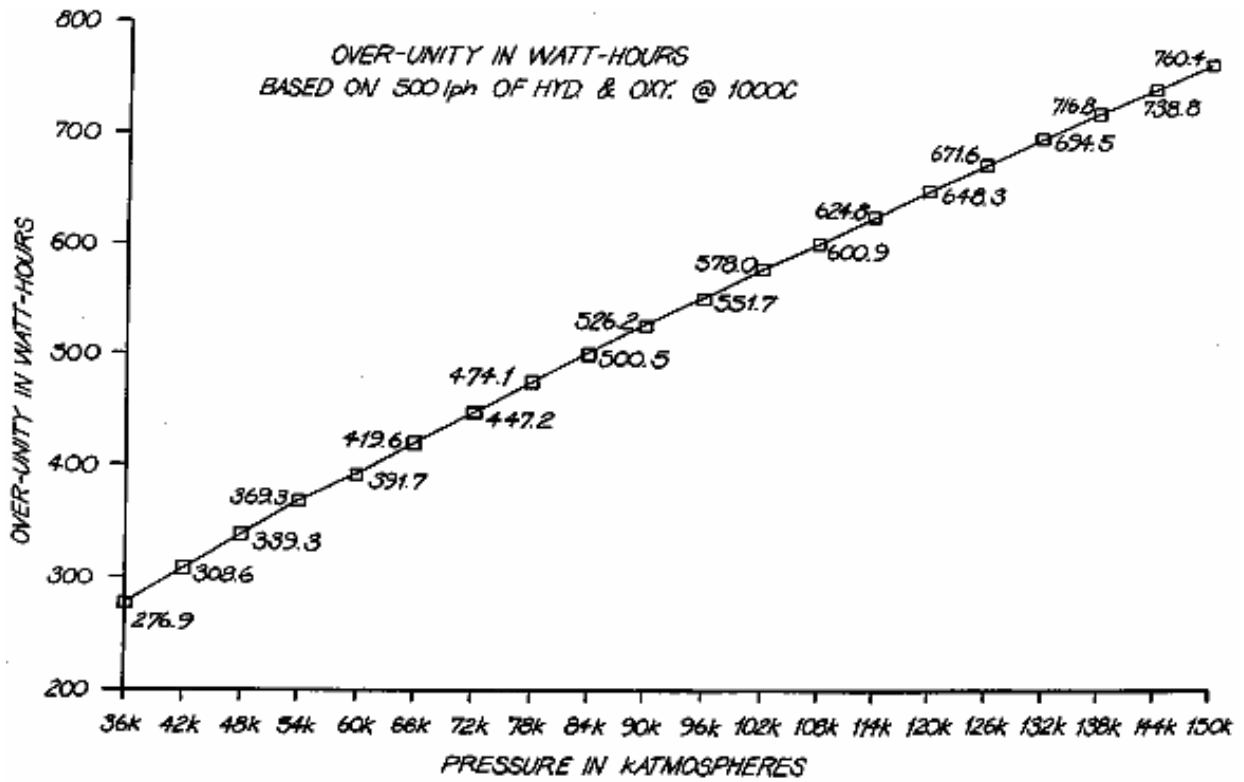

FIG. 29

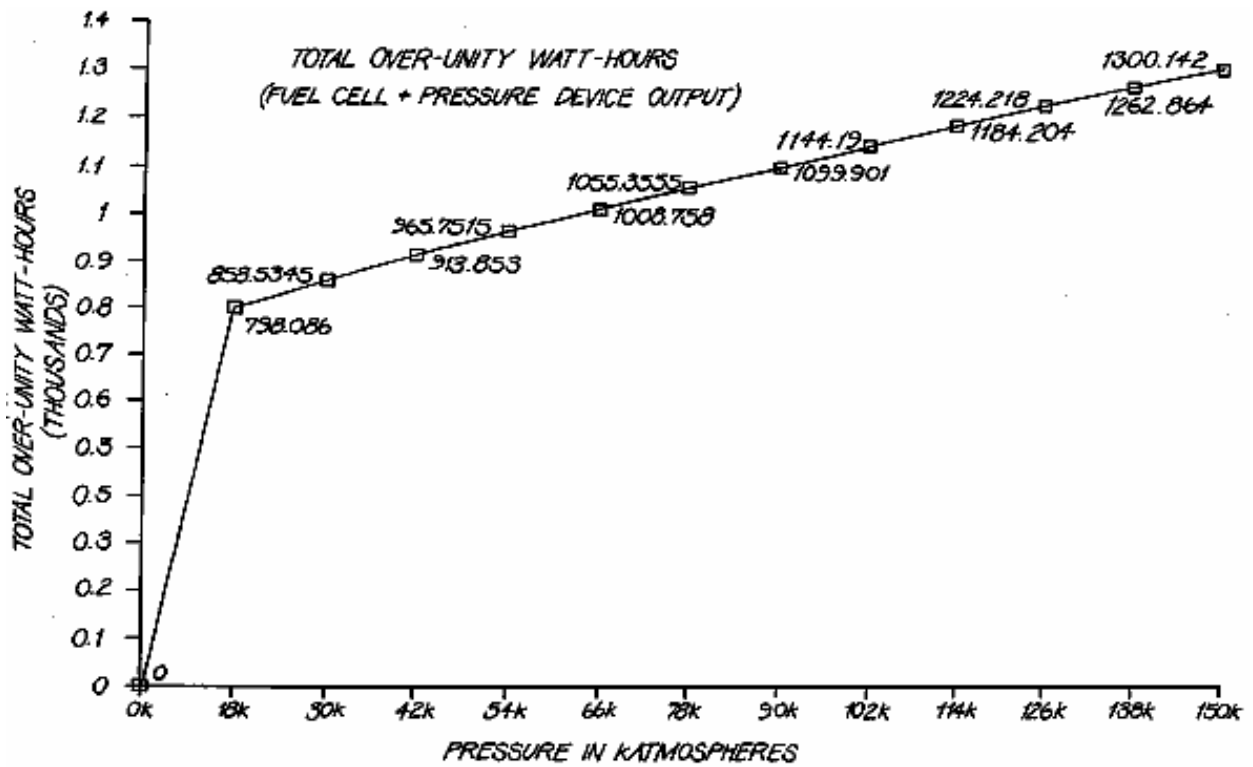

FIG. 30

Figs. 31a to 31e show a hydrogen/oxygen gas-driven internal combustion engine:

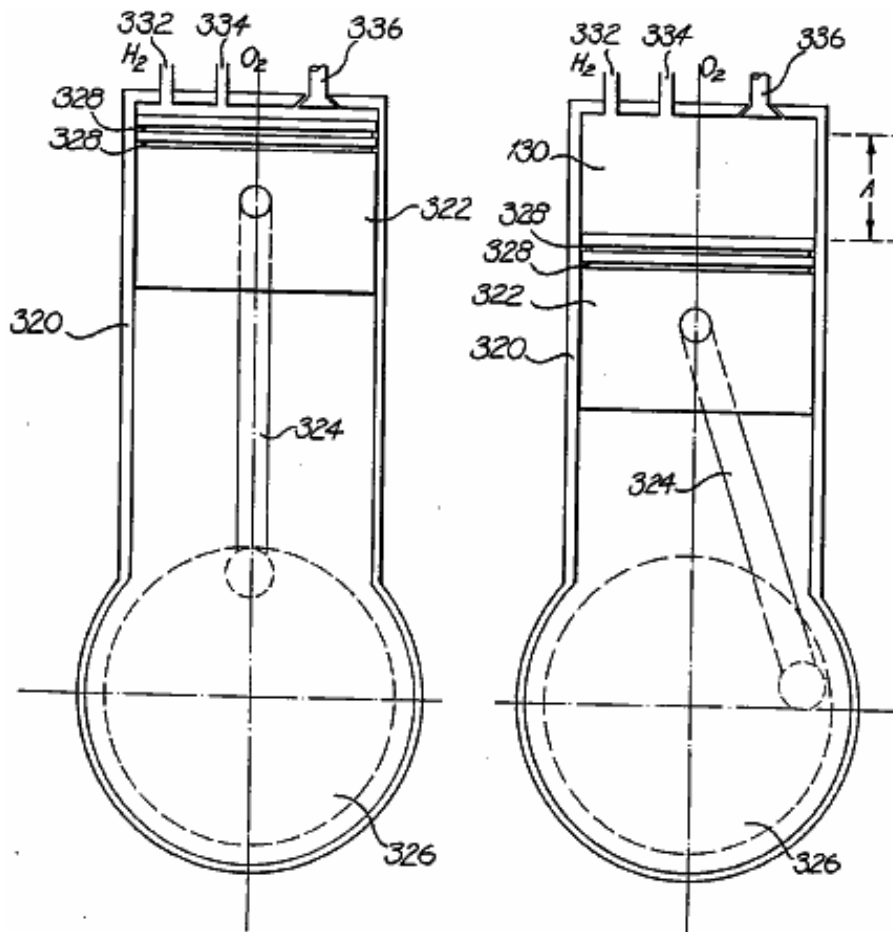

FIG. 31a

FIG. 31b

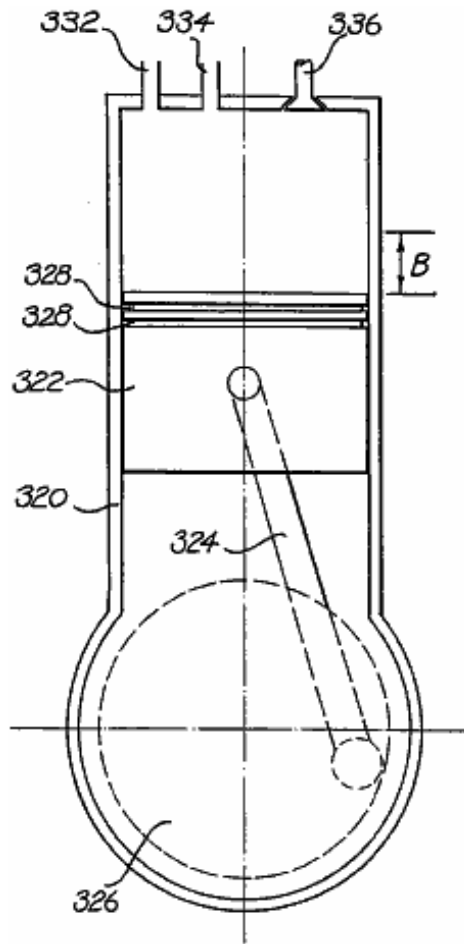

FIG. 31c

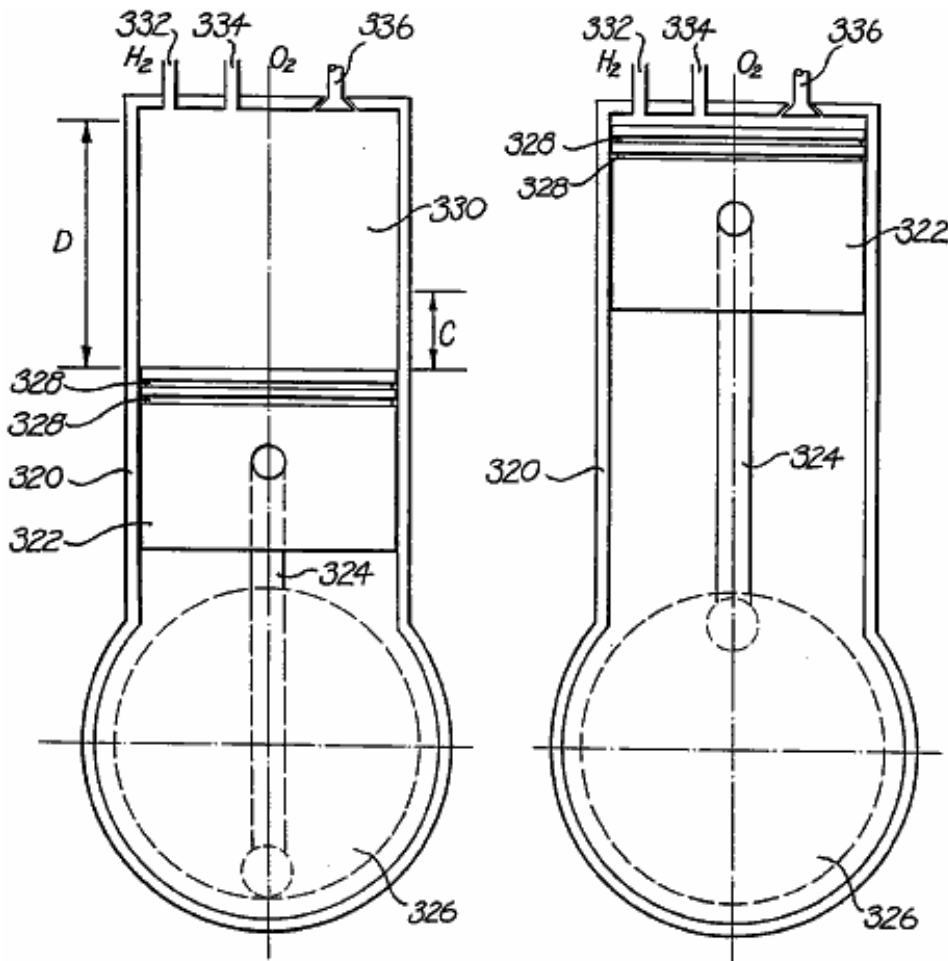
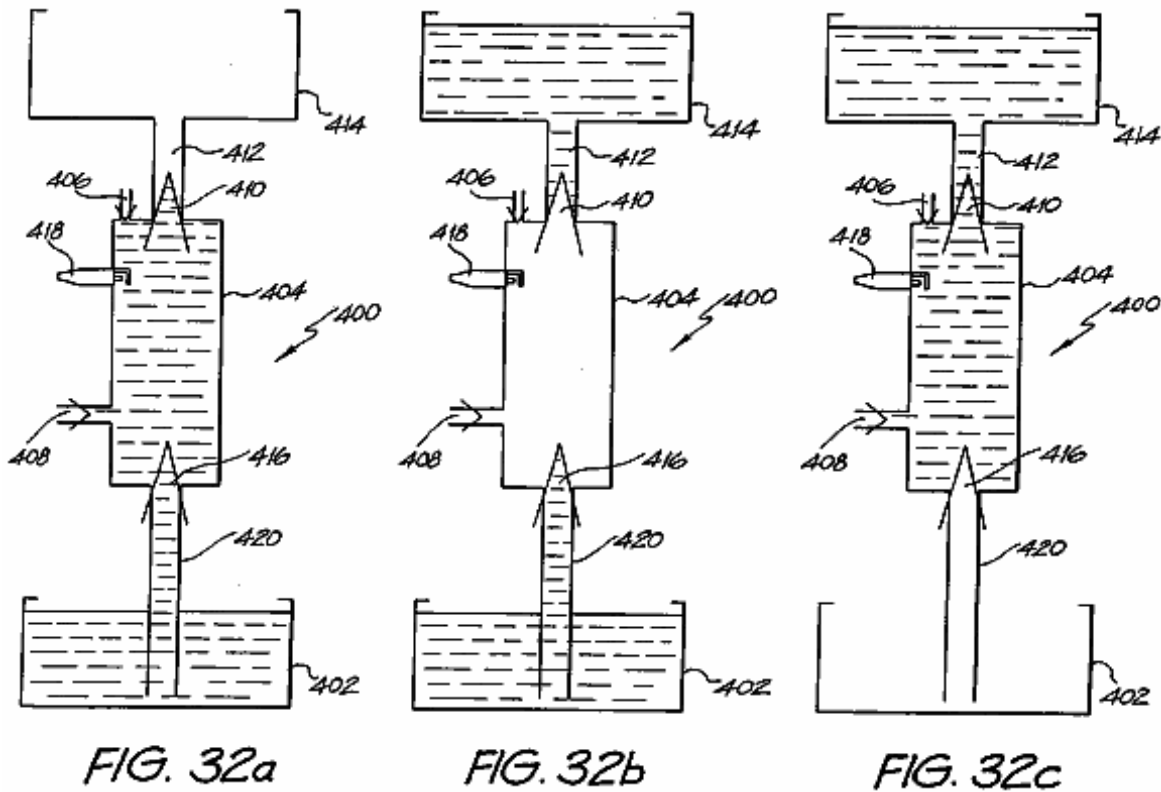

FIG. 31d

FIG. 31e

Figs. 32a-32c show a gas-driven implosion pump:



DETAILED DESCRIPTION AND BEST MODE OF PERFORMANCE

Fig.1A and Fig.2A show embodiments of a first and second type of cell plate 90, 98 as an end view. Fig.1B and Fig.2B are partial cross-sectional views along the respective mid-lines as shown. Common reference numerals have been used where appropriate. The plates 90, 98 can have the function of either an anode (+) or a cathode (-), as will become apparent. Each comprises an electrode disc 92 which is perforated with hexagonally shaped holes 96. The disc 92 is made from steel or resin-bonded carbon or conductive polymer material. The disc 92 is housed in a circular rim or sleeve 94. The function of the perforations 96 is to maximise the surface area of the electrode disc 92 and minimise the weight over solid constructions by 45%.

By way of example, for a disc of diameter 280 mm, the thickness of the disc must be 1 mm in order to allow the current density (which ranges from 90 A / 2,650 cm² - 100 A / 2,940 cm² of the anode or cathode) to be optimal. If the diameter of the plate is increased, which consequently increases the surface area, it is necessary to increase the thickness of the plate in order to maintain uniformity of conductance for the desired current density.

The hexagonal perforations in a 1 mm disc have a distance of 2 mm between the flats, twice the thickness of the plate in order to maintain the same total surface area prior to perforation, and be 1 mm away from the next adjacent perforation to allow the current density to be optimal. A (flat-to-flat) distance of 1 mm between the hexagonal perforations is required, because a smaller distance will result in thermal losses and a larger distance will add to the overall weight of the plate.

The sleeve 94 is constructed of PVC material and incorporates a number of equally spaced shaft holes 100,102. The holes are for the passage of interconnecting shafts provided in a stacked arrangement of the plates 90, 98 forming the common conductor for the respective anode and cathode plates. The further two upper holes 104,106 each support a conduit respectively for the out-flow of oxygen and hydrogen gases. The further holes 108,110 at the bottom of the sleeve 94 are provided for the inlet of water and electrolyte to the respective cell plates 90, 98.

Fig.3 shows an enlarged view of a portion of the cell plate 90 shown in Fig.1A. The port hole 104 is connected to the hexagonal perforations 96 within the sleeve 94 by an internal channel 112. A similar arrangement is in place for the other port hole 106, and for the water/electrolyte supply holes 108, 110.

If it is the case that the hydrogen and oxygen gases liberated are to be kept separate (i.e. not to be formed as an admixture), then it is necessary to separate those gases as they are produced. In the prior art this is achieved by use of diaphragms which block the passage of gases and effectively isolate the water/electrolyte on each side of the diaphragm. Ionic transfer thus is facilitated by the conductive nature of the diaphragm material (i.e. a water - diaphragm - water path). This results in an increase in the ionic resistance and hence a reduction in efficiency.

Fig.4 shows an exploded stacked arrangement of four cell plates, being an alternative stacking of two (anode) cell plates **90** and two (cathode) cell plates **98**. The two ends of the stacked arrangement of cell plates delineates a single cell unit **125**.

Interposed between each adjacent cell plate **90, 98** is a PTFE separation **116**. Although not shown in **Fig.4**, the cell unit includes separate hydrogen and oxygen gas conduits that respectively pass through the stacked arrangement of cell plates via the port holes **106, 104** respectively. In a similar way, conduits are provided for the supply of water/electrolyte, respectively passing through the holes **108, 110** at the bottom of the respective plates **90, 98**. Only two pairs of anode/cathode cell plates are shown. The number of such plates can be greatly increased per cell unit **125**.

Also not shown are the interconnecting conductive shafts that electrically interconnect alternative common cell plates. The reason for having a large diameter hole in one cell plate adjacent to a smaller diameter hole in the next cell plate, is so that an interconnecting shaft will pass through the larger diameter hole, and not make an electrical connection (i.e. insulated with PVC tubing) rather only forming an electrical connection between alternate (common) cell plates.

Fig.4 is an exploded view of one cell unit **125** arrangement. When fully constructed, all the elements are stacked in intimate contact. Mechanical fastening is achieved by use of one of two adhesives such as (a) "PUR-FECT LOK" (TM) 34-9002, which is a Urethane Reactive Hot Melt adhesive with a main ingredient of Methylene Bisphenyl/Diisocyanate (MDI), and (b) "MY-T-BOND" (TM) which is a PVC solvent based adhesive. Both adhesives are Sodium Hydroxide resistant, which is necessary because the electrolyte contains 20% Sodium Hydroxide. In that case the water/electrolyte only resides within the area contained within the cell plate sleeve **94**. Thus the only path for the inlet of water/electrolyte is by bottom channels **118, 122** and the only outlet for the gases is by the top channels **112, 120**. In a system constructed and tested by the inventor, the thickness of the cell plates **90, 98** is 1 mm (2 mm on the rim because of the PVC sleeve **94**), with a diameter of 336 mm. The cell unit **125** is segmented from the next cell by an insulating PVC segmentation disc **114**. A segmentation disc **114** is also placed at the beginning and end of the entire cell bank. If there is to be no separation of the liberated gases, then the PTFE membranes **116** are omitted and sleeve **94** is not required.

The PTFE membrane **116** is fibrous and has 0.2 to 1.0 micron interstices. A suitable type is type Catalogue Code J, supplied by Tokyo Roshi International Inc (Advantec). The water/electrolyte fills the interstices and ionic current flows only via the water - there is no contribution of ionic flow through the PTFE material itself. This leads to a reduction in the resistance to ionic flow. The PTFE material also has a 'bubble point' that is a function of pressure, hence by controlling the relative pressures at either side of the PTFE separation sheets, the gases can be 'forced' through the interstices to form an admixture, or otherwise kept separate. Other advantages of this arrangement include a lesser cost of construction, improved operational efficiency and greater resistance to faults.

Fig.5A is a stylised, and exploded, schematic view of a linear array of three series-connected cell units **125**. For clarity, only six interconnecting shafts **126-131** are shown. The shafts **126-131** pass through the respective shaft holes **102,100** in the various cell plates **90,98** in the stacked arrangement. The polarity attached to each of the exposed end shafts, to which the DC supply is connected also is indicated. The shafts **126-131** do not run the full length of the three cell banks **125**. The representation is similar to the arrangement shown in **Fig.7A** and **Fig.8**. One third the full DC source voltage appears across each anode/cathode cell plate pair **90,98**.

Further, the gas conduits **132,133**, respectively for hydrogen and oxygen, that pass through the port holes **104,106** in the cell plates **90,98** also are shown. In a similar way, water/electrolyte conduits **134,135**, passing through the water port holes **108,110** in the cell plates also are shown.

Fig.5B particularly shows how the relative potential difference in the middle cell bank **125** changes. That is, the plate electrode **90a** now functions as a cathode (i.e. relatively more negative) to generate hydrogen, and the plate electrode **98a** now functions as an anode (i.e. relatively more positive) to generate oxygen. This is the case for every alternate cell unit. The arrowheads shown in **Fig.5B** indicate the electron and ionic current circuit. **Fig.5C** is an electrical equivalent circuit representation of **Fig.5B**, where the resistive elements represent the ionic resistance between adjacent anode/cathode plates. Thus it can be seen that the cell units are connected in series.

Because of the change of function of the cell plates **90a** and **98a**, the complementary gases are liberated at each, hence the respective channels **112** are connected to the opposite gas conduit **132,133**. Practically, this can be achieved by the simple reversal of the cell plates **90,98**.

Fig.6 shows the three cell units **125** of **Fig.5A** connected to a gas collection arrangement. The cell units **125** are located within a tank **140** which is filled with water/electrolyte to the indicated level **h**. The water is consumed as the electrolysis process proceeds, and replenishing supply is provided via the inlet **152**. The water/electrolyte level **h** can be viewed via the sight glass **154**. In normal operation, the different streams of hydrogen and oxygen are produced and passed from the cell units **125** to respective rising columns **142,144**. That is, the pressure of electrolyte on opposed sides of the PTFE membranes **116** is equalised, thus the gases cannot admix.

The columns **142,144** also are filled with the water/electrolyte, and as it is consumed at the electrode plates, replenishing supply of electrolyte is provided by way of circulation through the water/electrolyte conduits **134,135**. The circulation is caused by entrainment by the liberated gases, and by the circulatory inducing nature of the conduits and columns.

The upper extent of the tank **140** forms two scrubbing towers **156,158**, respectively for the collection of oxygen and hydrogen gases. The gases pass up a respective column **142,144**, and out from the columns via openings therein at a point within the interleaved baffles **146**. The point where the gases exit the columns **142,144** is beneath the water level **h**, which serves to settle any turbulent flow and entrained electrolyte. The baffles **146** located above the level **h** scrub the gas of any entrained electrolyte, and the scrubbed gas then exits by respective gas outlet columns **148,150** and so to a gas receiver. The level **h** within the tank **140** can be regulated by any convenient means, including a float switch, again with the replenishing water being supplied by the inlet pipe **152**.

The liberated gases will always separate from the water/electrolyte solution by virtue of the difference in densities. Because of the relative height of the respective set of baffles, and due to the density differential between the gases and the water/electrolyte, it is not possible for the liberated hydrogen and oxygen gases to mix. The presence of the full volume of water within the tank **140** maintains the cell plates in an immersed state, and further serves to absorb the shock of any internal detonations should they occur.

In the event that a gas admixture is required, then firstly the two flow valves **136,137** respectively located in the oxygen gas outlet conduit **132** and water/electrolyte inlet port **134** are closed. This blocks the outlet path for the oxygen gas and forces the inlet water/electrolyte to pass to the inlet conduit **134** via a one-way check valve **139** and pump **138**. The water/electrolyte within the tank **140** is under pressure by virtue of its depth (volume), and the pump **138** operates to increase the pressure of water/electrolyte occurring about the anode cell plates **90,98a** to be at an increased pressure with respect to the water/electrolyte on the other side of the membrane **116**.

This pressure differential is sufficient to cause the oxygen gas to migrate through the membrane, thus admixed oxygen and hydrogen are liberated via the gas output conduit **133** and column **144**. Since there is no return path for the water/electrolyte supplied by the pump **138**, the pressure about the cell plates **90,98a** will increase further, and to a point where the difference is sufficient such that the water/electrolyte also can pass through the membrane **116**. Typically, pressure differential in the range of 1.5 - 10 psi is required to allow passage of gas, and a pressure differential in the range of 10 - 40 psi for water/electrolyte.

While only three cell units **125** are shown, clearly any number, connected in series, can be implemented.

Embodiments of the present invention now will be described. Where applicable, like reference numerals have been used.

Fig.7A and **Fig.7B** show a first type of cell plate **190** respectively as an end view and as an enlarged cross-sectional view along line **VIIb-VIIb**. The cell plate **190** differs from the previous cell plate **90** shown in **Fig.1A** and **Fig.1B** in a number of important aspects. The region of the electrode disc **192** received within the sleeve **194** now is perforated. The function of these perforations is to further reduce the weight of the cell plate **190**. The shaft holes **200,202** again pass through the electrode disc **192**, but so too do the upper holes **204,206** through which the conduits for the out-flow of liberated hydrogen and oxygen gases pass. The bottom holes **208,210**, provided for the inlet of water and electrolyte, now also are located in the region of the sleeve **194** coincident with the perforated edge margin of the electrode disc **192**. The channels **212,218** respectively communicating with the port hole **204** and the supply hole **210** also are shown.

Fig.8A and **Fig.8B** show a second type of cell plate **198** as a companion to the first cell plate **190**, and as the same respective views. The second cell plate **198** is somewhat similar to the cell plate **98** previously shown in **Fig.2A** and **Fig.2B**. The differences between them are the same as the respective differences between the cell

plate shown in **Fig.1A** and **Fig.1B** and the one shown in **Fig.7A** and **Fig.7B**. The arrangement of the respective channels **220,222** with respect to the port **206** and the water supply hole **208** also are shown.

In the fabrication of the cell plates **190,198**, the sleeve **94** is injection moulded from PVC plastics material formed about the edge margin of the electrode disc **192**.

The injection moulding process results in the advantageous forming of interconnecting sprues forming within the perforations **196** in the region of the disc **192** held within the sleeve **194**, thus firmly anchoring the sleeve **194** to the disc **192**.

Fig.9 is a view similar to **Fig.3**, but for the modified porting arrangement and perforations (shown in phantom where covered by the sleeve) of the region of the disc **192** within and immediately outside of the sleeve **194**.

Fig.10 shows a cell unit **225** in the form of an exploded alternating stacking of first and second cell plates **190,198**, much in the same manner as **Fig.4**. Only two pairs of anode/cathode cell plates are shown, however the number of such plates can be greatly increased per cell unit **225**. The membrane **216** preferably is type QR-HE silica fibre with the alternative being PTFE. Both are available from Tokyo Roshi International Inc. (Advantec) of Japan. Type QR-HE is a hydrophobic material having 0.2 to 1.0 micron interstices, and is capable of operation at temperatures up to 1,000⁰C. The cell unit **225** can be combined with other such cell units **225** to form an interconnected cell bank in the same manner as shown in **Fig.5A**, **Fig.5B** and **Fig.5C**.

Furthermore, the cell units can be put to use in a gas collection arrangement such as that shown in **Fig.6**. Operation of the gas separation system utilising the new cell plates **190,198** is in the same manner as previously described.

Fig.11 is an enlarged cross-sectional view of three cell plates in the vicinity of the oxygen port **204**. The cell plates comprise two of the first type of plate **190** shown in **Fig.7A** constituting a positive plate, and a single one of the second type of plate **198** shown in **Fig.8A** representing a negative plate. The location of the respective channels **212** for each of the positive cell plates **190** is shown as a dashed representation. The respective sleeves **194** of the three cell plates are formed from moulded PVC plastics as previously described, and in the region that forms the perimeter of the port **204** have a configuration particular to whether a cell plate is positive or negative. In the present case, the positive cell plates **190** have a flanged foot **230** that, in the assembled construction, form the contiguous boundary of the gas port **204**. Each foot **230** has two circumferential ribs **232** which engage corresponding circumferential grooves **234** in the sleeve **194** of the negative plate **198**.

The result of this arrangement is that the exposed metal area of the negative cell plates **198** always are insulated from the flow of oxygen gas liberated from the positive cell plates **190**, thus avoiding the possibility of spontaneous explosion by the mixing of the separated hydrogen and oxygen gases. This arrangement also overcomes the unwanted production of either oxygen gas or hydrogen gas in the gas port.

For the case of the gas port **206** carrying the hydrogen gas, the relative arrangement of the cell plates is reversed such that a flanged footing now is formed on the sleeve **194** of the other type of cell plate **198**. This represents the converse arrangement to that shown in **Fig.11**.

Fig.12A and **Fig.12B** show perspective side views of adjacent cell plates, with **Fig.12A** representing a positive cell plate **190** and **Fig.12B** representing a negative cell plate **198**. The gas port **206** thus formed is to carry hydrogen gas. The mating relationship between the flanged foot **230** and the end margin of the sleeve **194** of the positive cell plate **192** can be seen, particularly the interaction between the ribs **232** and the grooves **234**.

Fig.13 is a cross-sectional view of four cell plates formed into a stacked arrangement delimited by two segmentation plates **240**, together forming a cell unit **242**. Thus there are two positive cell plates **190** and two negative cell plates **198** in alternating arrangement. The cross-section is taken in the vicinity of a shaft hole **202** through which a negative conductive shaft **244** passes. The shaft **244** therefore is in intimate contact with the electrode discs **192** of the negative cell plates **198**. The electrode discs **192** of the positive cell plates **190** do not extend to contact the shaft **244**. The sleeve **194** of the alternating negative cell plates **198** again have a form of flanged foot **246**, although in this case the complementarily shaped ribs and grooves are formed only on the sleeve of the negative cell plates **198**, and not on the sleeve **194** of the positive cell plates **190**. The segmentation plates **240** serve to delimit the stacked plates forming a single cell unit **242**, with ones of the cell units **242** being stacked in a linear array to form a cell bank such as has been shown in **Fig.5A**.

A threaded shaft nut **250** acts as a spacer between adjacent electrodes connecting with the shaft **244**. **Fig.14** is a perspective view of the shaft nut **250** showing the thread **252** and three recesses **254** for fastening nuts, screws or the like.

In all of **Figs.11 to 13**, the separation membrane material **216** is not shown, but is located in the spaces **248** between adjacent cell plates **190,198**, extending to the margins of the electrode disks **192** in the vicinity of the gas ports **204,206** or the shaft holes **200,202**.

An electrolysis hydrogen and oxygen gas system incorporating a gas separation system, such as has been described above, can therefore be operated to establish respective high pressure stores of gas. That is, the separated hydrogen and oxygen gases liberated by the electrolysis process are stored in separate gas receivers or pressure vessels. The pressure in each will increase with the continuing inflow of gas.

Fig.15 shows an idealised electrolysis system, comprising an electrolysis cell **150** that receives a supply of water to be consumed. The electrolysis process is driven by a DC potential (**Es**) **152**. The potential difference applied to the cell **150** therefore must be sufficient to electrolyse the water into hydrogen and oxygen gas dependent upon, inter alia, the water pressure **PC** and the back pressure of gas **PB** acting on the surface of the water, together with the water temperature **Tc**. The separate liberated hydrogen and oxygen gases, by a priming function, are pressurised to a high value by storage in respective pressure vessels **158,160**, being carried by gas lines **154,156**.

The pressurised store of gases then are passed to an energy conversion device that converts the flow of gas under pressure to mechanical energy (e.g. a pressure drop device **162**). This mechanical energy recovered **WM** is available to be utilised to provide useful work. The mechanical energy **WM** also can be converted into electrical form, again to be available for use.

The resultant exhausted gases are passed via lines **164,166** to a combustion chamber **168**. Here, the gases are combusted to generate heat **QR**, with the waste product being water vapour. The recovered heat **QR** can be recycled to the electrolysis cell to assist in maintaining the advantageous operating temperature of the cell.

The previously described combustion chamber **168** can alternatively be a fuel cell. The type of fuel cell can vary from phosphoric acid fuel cells through to molten carbonate fuel cells and solid oxide cells. A fuel cell generates both heat (**QR**) and electrical energy (**WE**), and thus can supply both heat to the cell **150** or to supplement or replace the DC supply (**Es**) **152**.

Typically, these fuel cells can be of the type LaserCell™ as developed by Dr Roger Billings, the PEM Cell as available from Ballard Power Systems Inc. Canada or the Ceramic Fuel Cell (solid oxide) as developed by Ceramic Fuel Cells Ltd., Melbourne, Australia.

It is, of course, necessary to replenish the pressurised store of gases, thus requiring the continuing consumption of electrical energy. The recovered electrical energy **WE** is in excess of the energy required to drive electrolysis at the elevated temperature and is used to replace the external electrical energy source **152**, thereby completing the energy loop after the system is initially primed and started.

The present inventor has determined that there are some combinations of pressure and temperature where the efficiency of the electrolysis process becomes advantageous in terms of the total energy recovered, either as mechanical energy by virtue of a flow of gas at high pressure or as thermal energy by virtue of combustion (or by means of a fuel cell), with respect to the electrical energy consumed, to the extent of the recovered energy exceeding the energy required to sustain electrolysis at the operational pressure and temperature. This has been substantiated by experimentation. This notion has been termed "over-unity".

"Over-unity" systems can be categorised as broadly falling into three types of physical phenomena:

- (i) An electrical device which produces 100 Watts of electrical energy as output after 10 Watts of electrical energy is input thereby providing 90 Watts of overunity (electrical) energy.
- (ii) An electro-chemical device such as an electrolysis device where 10 Watts of electrical energy is input and 8 Watts is output being the thermal value of the hydrogen and oxygen gas output. During this process, 2 Watts of electrical energy converted to thermal energy is lost due to specific inefficiencies of the electrolysis system. Pressure - as the over-unity energy - is irrefutably produced during the process of hydrogen and oxygen gas generation during electrolysis. Pressure is a product of the containment of the two separated gases. The Law of Conservation of Energy (as referenced in "Chemistry Experimental Foundations", edited by Parry, R.W.; Steiner, L.E.; Tellefsen, R.L.; Dietz, P.M. Chap. 9, pp. 199-200, Prentice-Hall, New Jersey" and "An Experimental Science", edited by Pimentel, G.C., Chap. 7, pp. 115-117, W.H. & Freeman Co. San Francisco)

is in equilibrium where the 10 watts of input equals the 8 watts thermal energy output plus the 2 watts of losses. However, this Law ends at this point. The present invention utilises the apparent additional energy being the pressure which is a by-product of the electrolysis process to achieve over-unity.

(iii) An electro-chemical device which produces an excess of thermal energy after an input of electrical energy in such devices utilised in "cold fusion" e.g. 10 watts of electrical energy as input and 50 watts of thermal energy as output.

The present invention represents the discovery of means by which the previously mentioned second phenomenon can be embodied to result in "over-unity" and the realisation of 'free' energy. As previously noted, this is the process of liberating latent molecular energy. The following sequence of events describes the basis of the availability of over-unity energy.

In a simple two plate (anode/cathode) electrolysis cell, an applied voltage differential of 1.57 DC Volts draws 0.034 Amps per cm^2 and results in the liberation of hydrogen and oxygen gas from the relevant electrode plate. The electrolyte is kept at a constant temperature of 40°C , and is open to atmospheric pressure.

The inefficiency of an electrolytic cell is due to its ionic resistance (approximately 20%), and produces a by-product of thermal energy. The resistance reduces, as does the minimum DC voltage required to drive electrolysis, as the temperature increases. The overall energy required to dissociate the bonding electrons from the water molecule also decreases as the temperature increases. In effect, thermal energy acts as a catalyst to reduce the energy requirements in the production of hydrogen and oxygen gases from the water molecule. Improvements in efficiency are obtainable by way of a combination of thermal energy itself and the NaOH electrolyte both acting to reduce the resistance of the ionic flow of current.

Thermal 'cracking' of the water molecule is known to occur at $1,500^{\circ}\text{C}$, whereby the bonding electrons are dissociated and subsequently 'separate' the water molecule into its constituent elements in gaseous form. This thermal cracking then allows the thermal energy to become a consumable. Insulation can be introduced to conserve thermal energy, however there will always be some thermal energy losses.

Accordingly, thermal energy is both a catalyst and a consumable (in the sense that the thermal energy excites bonding electrons to a higher energetic state) in the electrolysis process. A net result from the foregoing process is that hydrogen is being produced from thermal energy because thermal energy reduces the overall energy requirements of the electrolysis system.

Referring to the graph titled "Flow Rate At A Given Temperature" shown in **Fig.16**, it has been calculated that at a temperature of $2,000^{\circ}\text{C}$, 693 litres of hydrogen/oxygen admixed gas (2:1) will be produced. The hydrogen content of this volume is 462 litres. At an energy content of 11 BTUs per litre of hydrogen, this then gives an energy amount of 5,082 BTUs (11×462). Using the BTU:kilowatt conversion factor of 3413:1, 5,082 BTUs of the hydrogen gas equate to 1.49 kW. Compare this with 1 kW to produce the 693 litres of hydrogen/oxygen (including 463 litres of hydrogen). The usage of this apparatus therefore identifies that thermal energy, through the process of electrolysis, is being converted into hydrogen. These inefficiencies, i.e. increased temperature and NaOH electrolyte, reduce with temperature to a point at approximately 1000°C where the ionic resistance reduces to zero, and the volumetric amount of gases produced per kWh increases.

The lowering of DC voltage necessary to drive electrolysis by way of higher temperatures is demonstrated in the graph in **Fig.17** titled "The Effect of temperature on Cell Voltage".

The data in **Fig.16** and **Fig.17** have two sources. Cell voltages obtained from 0°C up to and including 100°C were those obtained by an electrolysis system as described above. Cell voltages obtained from 150°C up to $2,000^{\circ}\text{C}$ are theoretical calculations presented by an acknowledged authority in this field, Prof. J. O'M. Bockris. Specifically, these findings were presented in "Hydrogen Energy, Part A, Hydrogen Economy", Miami Energy Conference, Miami Beach, Florida, 1974, edited by T. Nejat Veziroglu, Plenum Press, pp. 371-379. These calculations appear on page 374.

By inspection of **Fig.17** and **Fig.18** (titled "Flow Rate of Hydrogen and Oxygen at 2:1"), it can be seen that as temperature increases in the cell, the voltage necessary to dissociate the water molecule is reduced, as is the overall energy requirement. This then results in a higher gas flow per kWh.

As constrained by the limitation of the materials within the system, the operationally acceptable temperature of the system is 1000°C . This temperature level should not, however, be considered as a restriction. This temperature is based on the limitations of the currently commercially available materials. Specifically, this system can utilise material such as compressed Silica Fibre for the sleeve around the electrolysis plate and hydrophobic Silica Fibre

(part no. QR-100HE supplied by Tokyo Roshi International Inc., also known as "Advantec") for the diaphragm (as previously discussed) which separates the electrolysis disc plates. In the process of assembling the cells, the diaphragm material and sleeved electrolysis plates **190,198** are adhered to one another by using high-temperature-resistant silica adhesive (e.g. the "Aremco" product "Ceramabond 618" which has an operational tolerance specification of 1,000⁰C).

For the electrolysis cell described above, with the electrolyte at 1,000⁰C and utilising electrical energy at the rate of 1 kWh, 167 litres of oxygen and 334 litres of hydrogen per hour will be produced.

The silica fibre diaphragm **116** previously discussed separates the oxygen and hydrogen gas streams by the mechanism of density separation, and produce a separate store of oxygen and hydrogen at pressure. Pressure from the produced gases can range from 0 to 150,000 Atmospheres. At higher pressures, density separation may not occur. In this instance, the gas molecules can be magnetically separated from the electrolyte if required.

In reference to the experiments conducted by Messrs Hamann and Linton (S.D. Hamann and M. Linton, Trans. Faraday Soc. 62,2234-2241, specifically, page 2,240), this research has proven that higher pressures can produce the same effect as higher temperatures in that the conductivity increases as temperature and/or pressure increases. At very high pressures, the water molecule dissociates at low temperatures. The reason for this is that the bonding electron is more readily removed when under high pressure. The same phenomenon occurs when the bonding electrons are at a high temperature (e.g. 1,500⁰C) but at low pressures.

As shown in **Fig.15**, hydrogen and oxygen gases are separated into independent gas streams flowing into separate pressure vessels **158,160** capable of withstanding pressures up to 150,000 Atmospheres. Separation of the two gases thereby eliminates the possibility of detonation. It should also be noted that high pressures can facilitate the use of high temperatures within the electrolyte because the higher pressure elevates the boiling point of water.

Experimentation shows that 1 litre of water can yield 1,850 litres of hydrogen/oxygen (in a ratio of 2: 1) gas mix after decomposition, this significant differential(1:1,850) is the source of the pressure. Stripping the bonding electrons from the water molecule, which subsequently converts liquid into a gaseous state, releases energy which can be utilised as pressure when this occurs in a confined space.

A discussion of experimental work in relation to the effects of pressure in electrolysis processes can be obtained from "Hydrogen Energy, Part A, Hydrogen Economy Miami Energy Conference, Miami Beach, Florida, 1974, edited by T. Nejat Veziroglu, Plenum Press". The papers presented by F.C. Jensen and F.H. Schubert on pages 425 to 439 and by John B. Pangborn and John C. Sharer on pages 499 to 508 are of particular relevance.

Attention must be drawn to the above published material; specifically on page 434, third paragraph, where reference is made to "Fig.7 shows the effect of pressure on cell voltage...". Fig. 7 on page 436 ("Effect of Pressure on SFWES Single Cell") indicates that if pressure is increased, then so too does the minimum DC voltage.

These quotes were provided for familiarisation purposes only and not as demonstrable and empirical fact. Experimentation by the inventor factually indicates that increased pressure (up to 2,450 psi) in fact lowers the minimum DC voltage.

This now demonstrable fact, whereby increased pressure actually lowers minimum DC voltage, is further exemplified by the findings of Messrs. Nayar, Ragunathan and Mitra in 1979 which can be referenced in their paper: "Development and operation of a high current density high pressure advanced electrolysis cell".

Nayar, M.G.; Ragunathan, P. and Mitra, S.K. International Journal of Hydrogen Energy (Pergamon Press Ltd.), 1980, Vol. 5, pp. 65-74. Their Table 2 on page 72 expressly highlights this as follows: "At a Current density (ASM) of 7,000 and at a temperature of 80⁰C, the table shows identical Cell voltages at both pressures of 7.6 kg/cm² and 11.0 kg/cm². But at Current densities of 5,000, 6,000, 8,000, 9,000 and 10,000 (at a temperature of 80⁰C), the Cell voltages were lower at a pressure of 11.0 kg/cm² than at a pressure of 7.6 kg/cm². " The present invention thus significantly improves on the apparatus employed by Mr. M.G. Nayar, et al, at least in the areas of cell plate materials, current density and cell configuration.

In the preferred form the electrode discs **192** are perforated mild steel, conductive polymer or perforated resin bonded carbon cell plates. The diameter of the perforated holes **196** is chosen to be twice the thickness of the plate in order to maintain the same total surface area prior to perforation. Nickel was utilised in the noted prior art system. That material has a higher electrical resistance than mild steel or carbon, providing the present invention with a lower voltage capability per cell.

The previously mentioned prior art system quotes a minimum current density (after conversion from ASM to Amps per square cm.) at 0.5 Amps per cm². The present invention operates at the ideal current density, established by experimentation, to minimise cell voltage which is 0.034 Amps per cm².

When compared with the aforementioned system, an embodiment of the present invention operates more efficiently due to a current density improvement by a factor of 14.7, the utilisation of better conducting cell plate material which additionally lowers cell voltage, a lower cell voltage of 1.49 at 80⁰C as opposed to 1.8 volts at 80⁰C, and a compact and efficient cell configuration.

In order to further investigate the findings of Messrs. M.G. Nayer, et al, the inventor conducted experiments utilising much higher pressures. For Nayer, et al, the pressures were 7.6 kg/cm² to 11.0 kg/cm², whereas inventor's pressures were 0 psi to 2,450 psi in an hydrogen/oxygen admixture electrolysis system.

This electrolysis system was run from the secondary coil of a transformer set approximately at maximum 50 Amps and with an open circuit voltage of 60 Volts. In addition, this electrolysis system is designed with reduced surface area in order that it can be housed in an hydraulic container for testing purposes. The reduced surface area subsequently caused the gas production efficiency to drop when compared with previous (i.e. more efficient) prototypes. The gas flow rate was observed to be approximately 90 litres per hour at 70⁰C in this system as opposed to 310 litres per hour at 70⁰C obtained from previous prototypes. All of the following data and graphs have been taken from the table shown in **Fig.19**.

Referring to **Fig.20** (titled "Volts Per Pressure Increase"), it can be seen that at a pressure of 14.7 psi (i.e. 1 Atmosphere), the voltage measured as 38.5V and at a pressure of 2,450 psi, the voltage measured as 29.4V. This confirms the findings of Nayar et al that increased pressure lowers the system's voltage. Furthermore, these experiments contradict the conclusion drawn by F.C. Jensen and F.H. Schubert ("Hydrogen Energy, Part A, Hydrogen Economy Miami Energy Conference, Miami Beach, Florida, 1974, edited by T. Nejat Veziroglu, Plenum Press", pp 425 to 439, specifically Fig. 7 on page 434) being that "... as the pressure of the water being electrolysed increases, then so too does the minimum DC Voltage". As the inventor's experiments are current and demonstrable, the inventor now presents his findings as the current state of the art and not the previously accepted findings of Schubert and Jensen.

Referring to **Fig.21** (titled "Amps Per Pressure Increase"), it can be seen that at a pressure of 14.7 psi (i.e. 1 Atmosphere being Test Run No. 1), the current was measured as 47.2A and at a pressure of 2,450 psi (Test Run No. 20), the current was measured as 63A.

Referring to **Fig.22** (titled "Kilowatts Per Pressure Increase"), examination of the power from Test Run No. 1 (1.82 kW) through to Test Run No. 20 (1.85 kW) indicates that there was no major increase in energy input required at higher pressures in order to maintain adequate gas flow.

Referring to **Fig.23** (titled "Resistance (Ohms) Per Pressure Increase"), the resistance was calculated from Test Run No. 1 (0.82 ohms) to Test Run No. 20 (0.47 ohms). These data indicate that the losses due to resistance in the electrolysis system at high pressures are negligible.

Currently accepted convention has it that dissolved hydrogen, due to high pressures within the electrolyte, would cause an increase in resistance because hydrogen and oxygen are bad conductors of ionic flow. The net result of which would be that this would decrease the production of gases.

These tests indicate that the ions find their way around the H₂ and O₂ molecules within the solution and that at higher pressures, density separation will always cause the gases to separate from the water and facilitate the movement of the gases from the electrolysis plates. A very descriptive analogy of this phenomenon is where the ion is about the size of a football and the gas molecules are each about the size of a football field thereby allowing the ion a large manoeuvring area in which to skirt the molecule.

Referring to **Fig.24** (titled "Pressure Differential (Increase)"), it can be seen that the hydrogen/oxygen admixture caused a significant pressure increase on each successive test run from Test Run No. 1 to Test Run No. 11. Test Runs thereafter indicated that the hydrogen/oxygen admixture within the electrolyte solution imploded at the point of conception (being on the surface of the plate).

Referring again to the table of **Fig.19**, it can be noted the time taken from the initial temperature to the final temperature in Test Run No. 12 was approximately half the time taken in Test Run No. 10. The halved elapsed time (from 40⁰C to 70⁰C) was due to the higher pressure causing the hydrogen/oxygen admixture to detonate which subsequently imploded within the system thereby releasing thermal energy.

Referring to the table shown in **Fig.25** (titled "Flow Rate Analysis Per Pressure Increase"), these findings were brought about from flow rate tests up to 200 psi and data from **Fig.24**. These findings result in the data of **Fig.25** concerning gas flow rate per pressure increase. Referring to **Fig.25**, it can be seen that at a pressure of 14.7 psi (1 Atmosphere) a gas production rate of 88 litres per kWh is being achieved. At 1,890 psi, the system produces 100 litres per kWh. These findings point to the conclusion that higher pressures do not affect the gas production rate of the system, the gas production rate remains constant between pressures of 14.7 psi (1 Atmosphere) and 1,890 psi.

Inferring from all of the foregoing data, increased pressure will not adversely affect cell performance (gas production rate) in separation systems where hydrogen and oxygen gases are produced separately, nor as a combined admixture. Therefore, in an enclosed electrolysis system embodying the invention, the pressure can be allowed to build up to a predetermined level and remain at this level through continuous (on-demand) replenishment. This pressure is the over-unity energy because it has been obtained during the normal course of electrolysis operation without additional energy input. This over-unity energy (i.e. the produced pressure) can be utilised to maintain the requisite electrical energy supply to the electrolysis system as well as provide useful work.

The following formulae and subsequent data do not take into account the apparent efficiencies gained by pressure increase in this electrolysis system such as the gained efficiency factors highlighted by the previously quoted Hamann and Linton research. Accordingly, the over-unity energy should therefore be considered as conservative claims and that such claimed over-unity energy would in fact occur at much lower pressures.

This over-unity energy can be formalised by way of utilising a pressure formula as follows: $E = (P - P_0) V$ which is the energy (E) in Joules per second that can be extracted from a volume (V) which is cubic meters of gas per second at a pressure (P) measured in Pascals and where P_0 is the ambient pressure (i.e. 1 Atmosphere).

In order to formulate total available over-unity energy, we will first use the above formula but will not take into account efficiency losses. The formula is based on a flow rate of 500 litres per kWh at 1,000°C. When the gases are produced in the electrolysis system, they are allowed to self-compress up to 150,000 Atmospheres which will then produce a volume (V) of $5.07 \times 10^{-8} \text{ m}^3/\text{sec}$.

$$\text{Work [Joules/sec]} = ((150-1) \times 10^8) 5.07 \times 10^{-8} \text{ m}^3/\text{sec} = 760.4 \text{ Watts}$$

The graphs in **Figs.27-29** (Over-Unity in watt-hours) indicate over-unity energy available excluding efficiency losses. However, in a normal work environment, inefficiencies are encountered as energy is converted from one form to another.

The results of these calculations will indicate the amount of surplus- over-unity energy after the electrolysis system has been supplied with its required 1 kWh to maintain its operation of producing the 500 lph of hydrogen and oxygen (separately in a ratio of 2:1).

The following calculations utilise the formula stated above, including the efficiency factor. The losses which we will incorporate will be 10% loss due to the energy conversion device (converting pressure to mechanical energy, which is represented by device **162** in **Fig.15**) and 5% loss due to the DC generator W_e providing a total of 650 watt-hours which results from the pressurised gases.

Returning to the 1 kWh, which is required for electrolysis operation, this 1 kWh is converted (during electrolysis) to hydrogen and oxygen. The 1 kWh of hydrogen and oxygen is fed into a fuel cell. After conversion to electrical energy in the fuel cell, we are left with 585 watt-hours due to a 65 % efficiency factor in the fuel cell (35 % thermal losses are fed back into electrolysis unit **150** via Q_r in **Fig.15**).

Fig.30 graphically indicates the total over-unity energy available combining a fuel cell with the pressure in this electrolysis system in a range from 0 kAtmospheres to 150 kAtmospheres. The data in **Fig.30** have been compiled utilising the previously quoted formulae where the watt-hours findings are based on incorporating the 1 kWh required to drive the electrolysis system, taking into account all inefficiencies in the idealised electrolysis system (complete the loop) and then adding the output energy from the pressurised electrolysis system with the output of the fuel cell. This graph thereby indicates the energy break-even point (at approximately 66 kAtmospheres) where the idealised electrolysis system becomes self-sustaining.

In order to scale up this system for practical applications, such as power stations that will produce 50 MW of available electrical energy (as an example), the required input energy to the electrolysis system will be 170 MW (which is continually looped).

The stores of high pressure gases can be used with a hydrogen/oxygen internal combustion engine, as shown in **Figs. 31A to 31E**. The stores of high pressure gases can be used with either forms of combustion engines having an expansion stroke, including turbines, rotary, Wankel and orbital engines. One cylinder of an internal combustion engine is represented, however it is usually, but not necessarily always the case, that there will be other cylinders in the engine offset from each other in the timing of their stroke. The cylinder **320** houses a piston head **322** and crank **324**, with the lower end of the crank **324** being connected with a shaft **326**. The piston head **322** has conventional rings **328** sealing the periphery of the piston head **322** to the bore of the cylinder **320**.

A chamber **330**, located above the top of the piston head **322**, receives a supply of regulated separated hydrogen gas and oxygen gas via respective inlet ports **332,334**. There is also an exhaust port **336** venting gas from the chamber **330**.

The engine's operational cycle commences as shown in **Fig.31A**, with the injection of pressurised hydrogen gas, typically at a pressure of 5,000 psi to 30,000 psi, sourced from a reservoir of that gas (not shown). The oxygen gas port **334** is closed at this stage, as is the exhaust port **336**. Therefore, as shown in **Fig.31B**, the pressure of gas forces the piston head **322** downwards, thus driving the shaft **326**. The stroke is shown as distance "A".

At this point, the oxygen inlet **334** is opened to a flow of pressurised oxygen, again typically at a pressure of 5,000 psi to 30,000 psi, the volumetric flow rate being one half of the hydrogen already injected, so that the hydrogen and oxygen gas within the chamber **330** are the proportion 2:1.

Conventional expectations when injecting a gas into a confined space (e.g. such as a closed cylinder) are that gases will have a cooling effect on itself and subsequently its immediate environment (e.g. cooling systems/refrigeration). This is not the case with hydrogen. The inverse applies where hydrogen, as it is being injected, heats itself up and subsequently heats up its immediate surroundings. This effect, being the inverse of other gases, adds to the efficiency of the overall energy equation when producing over-unity energy.

As shown in **Fig.31C**, the piston head **322** has moved a further stroke, shown as distance "B", at which time there is self-detonation of the hydrogen and oxygen mixture. The hydrogen and oxygen inlets **332,334** are closed at this point, as is the exhaust **336**.

As shown in **Fig.31D**, the piston head is driven further downwards by an additional stroke, shown as distance "C", to an overall stroke represented by distance "D". The added piston displacement occurs by virtue of the detonation.

As shown in **Fig.31E**, the exhaust port **336** is now opened, and by virtue of the kinetic energy of the shaft **326** (or due to the action of others of the pistons connected with the shaft), the piston head **322** is driven upwards, thus exhausting the waste steam by the exhaust port **336** until such time as the situation of **Fig.31E** is achieved so that the cycle can repeat.

A particular advantage of an internal combustion motor constructed in accordance with the arrangement shown in **Figs.31A to 31E** is that no compression stroke is required, and neither is an ignition system required to ignite the working gases, rather the pressurised gases spontaneously combust when provided in the correction proportion and under conditions of high pressure.

Useful mechanical energy can be extracted from the internal combustion engine, and be utilised to do work. Clearly the supply of pressurised gas must be replenished by the electrolysis process in order to allow the mechanical work to continue to be done. Nevertheless, the inventor believes that it should be possible to power a vehicle with an internal combustion engine of the type described in **Figs.31A to 31E**, with that vehicle having a store of the gases generated by the electrolysis process, and still be possible to undertake regular length journeys with the vehicle carrying a supply of the gases in pressure vessels (somewhat in a similar way to, and the size of, petrol tanks in conventional internal combustion engines).

When applying over-unity energy in the form of pressurised hydrogen and oxygen gases to this internal combustion engine for the purpose of providing acceptable ranging (i.e. distance travelled), pressurised stored gases as mentioned above may be necessary to overcome the problem of mass inertia (e.g. stop-start driving). Inclusion of the stored pressurised gases also facilitates the ranging (i.e. distance travelled) of the vehicle.

Over-unity energy (as claimed in this submission) for an average sized passenger vehicle will be supplied at a continual rate of between 20 kW and 40 kW. In the case of an over-unity energy supplied vehicle, a supply of water (e.g. similar to a petrol tank in function) must be carried in the vehicle.

Clearly electrical energy is consumed in generating the gases. However it is also claimed by the inventor that an over-unity energy system can provide the requisite energy thereby overcoming the problem of the consumption of

fossil fuels either in conventional internal combustion engines or in the generation of the electricity to drive the electrolysis process by coal, oil or natural gas generators.

Experimentation by the inventor shows that if 1,850 litres of hydrogen/oxygen gas mix (in a ratio of 2:1) is detonated, the resultant product is 1 litre of water and 1,850 litres of vacuum if the thermal value of the hydrogen and oxygen gas mix is dissipated. At atmospheric pressure, 1 litre of admixed hydrogen/oxygen (2:1) contains 11 BTUs of thermal energy. Upon detonation, this amount of heat is readily dissipated at a rate measured in microseconds which subsequently causes an implosion (inverse differential of 1,850:1). Tests conducted by the inventor at 3 atmospheres (hydrogen/oxygen gas at a pressure of 50 psi) have proven that complete implosion does not occur. However, even if the implosion container is heated (or becomes heated) to 400C, total implosion will still occur.

This now available function of idiosyncratic implosion can be utilised by a pump taking advantage of this action. Such a pump necessarily requires an electrolysis gas system such as that described above, and particularly shown in **Fig.6**.

Figs. 32A-32C show the use of implosion and its cycles in a pumping device **400**. The pump **400** is initially primed from a water inlet **406**. The water inlet **406** then is closed-off and the hydrogen/oxygen gas inlet **408** is opened.

As shown in **Fig.32B**, the admixed hydrogen/oxygen gas forces the water upward through the one-way check valve **410** and outlet tube **412** into the top reservoir **414**. The one-way check valves **410,416** will not allow the water to drop back into the cylinder **404** or the first reservoir **402**. This force equates to lifting the water over a distance. The gas inlet valve **408** then is closed, and the spark plug **418** detonates the gas mixture which causes an implosion (vacuum). Atmospheric pressure forces the water in reservoir **402** up through tube **420**.

Fig.32C shows the water having been transferred into the pump cylinder **404** by the previous action. The implosion therefore is able to 'lift' the water from the bottom reservoir **402** over a distance which is approximately the length of tube **420**.

The lifting capacity of the implosion pump is therefore approximately the total of the two distances mentioned. This completes the pumping cycle, which can then be repeated after the reservoir **402** has been refilled.

Significant advantages of this pump are that it does not have any diaphragms, impellers nor pistons thereby essentially not having any moving parts (other than solenoids and one-way check valves). As such, the pump is significantly maintenance free when compared to current pump technology.

It is envisaged that this pump with the obvious foregoing positive attributes and advantages in pumping fluids, semi-fluids and gases can replace all currently known general pumps and vacuum pumps with significant benefits to the end-user of this pump.

CLAIMS

- 1.** A looped energy system for the generation of excess energy available to do work, said system comprising:
An electrolysis cell unit receiving a supply of water and for liberating separated hydrogen gas and oxygen gas by electrolysis due to a DC voltage applied across respective anodes and cathodes of said cell unit;
Hydrogen gas receiver means for receiving and storing hydrogen gas liberated by said cell unit;
Oxygen gas receiver means for receiving and storing oxygen gas liberated by said cell unit;
Gas expansion means for expanding said stored gases to recover expansion work; and
Gas combustion means for mixing and combusting said expanded hydrogen gas and oxygen gas to recover combustion work; and in which a proportion of the sum of the expansion work and the combustion work sustains electrolysis of said cell unit to retain operational gas pressure in said hydrogen and oxygen gas receiver means such that the energy system is self-sustaining and there is excess energy available from said sum of energies.
- 2.** A looped energy system for the generation of excess energy available to do work, said system comprising:
An electrolysis cell unit receiving a supply of water and for liberating separated hydrogen gas and oxygen gas by electrolysis due to a DC voltage applied across respective anodes and cathodes of said cell unit;
Hydrogen gas receiver means for receiving and storing hydrogen gas liberated by said cell unit;
Oxygen gas receiver means for receiving and storing oxygen gas liberated by said cell unit;
Gas expansion means for expanding said stored gases to recover expansion work; and
Fuel cell means for recovering electrical work from said expanded hydrogen gas and oxygen gas; and wherein a proportion of the sum of the expansion work and the recovered electrical work sustains electrolysis of said cell

unit to retain operational gas pressure in said hydrogen and oxygen gas receiver means such that the energy system is self-sustaining and there is excess energy available from said sum of energies.

3. An energy system as claimed in Claim 1 or Claim 2 further comprising mechanical-to-electrical energy conversion means coupled to said gas expansion means to convert the expansion work to electrical expansion work to be supplied as said DC voltage to said cell unit.
4. An energy system as claimed in any one of the preceding claims wherein said water in said cell unit is maintained above a predetermined pressure by the effect of back pressure from said gas receiver means and above a predetermined temperature resulting from input heat arising from said combustion work and/or said expansion work.
5. A method for the generation of excess energy available to do work by the process of electrolysis, said method comprising the steps of:
Electrolysing water by a DC voltage to liberate separated hydrogen gas and oxygen gas;
Separately receiving and storing said hydrogen gas and oxygen gas in a manner to be self-pressuring;
Separately expanding said stores of gas to recover expansion work;
Combusting said expanded gases together to recover combustion work; and
Applying a portion of the sum of the expansion work and the combustion work as said DC voltage to retain operational gas pressures and sustain said electrolysing step, there thus being excess energy of said sum available.
6. A method for the generation of excess energy available to do work by the process of electrolysis, said method comprising the steps of:
Electrolysing water by a DC voltage to liberate separated hydrogen gas and oxygen gas;
Separately receiving and storing said hydrogen gas and oxygen gas in a manner to be self-pressuring;
Separately expanding said stores of gas to recover expansion work;
Passing said expanded gases together through a fuel cell to recover electrical work; and
Applying a portion of the sum of the expansion work and the recovered electrical work as said DC voltage to retain operational gas pressures and sustain said electrolysing step, there thus being excess energy of said sum available.
7. An internal combustion engine powered by hydrogen and oxygen comprising:
At least one cylinder and at least one reciprocating piston within the cylinder;
A hydrogen gas input port in communication with the cylinder for receiving a supply of pressurised hydrogen;
An oxygen gas input port in communication with the cylinder for receiving a supply of pressurised oxygen; and
An exhaust port in communication with the cylinder and wherein the engine is operable in a two-stroke manner whereby, at the top of the stroke, hydrogen gas is supplied by the respective inlet port to the cylinder driving the piston downwards, oxygen gas then is supplied by the respective inlet port to the cylinder to drive the cylinder further downwards, after which time self-detonation occurs and the piston moves to the bottom of the stroke and upwardly again with said exhaust port opened to exhaust water vapour resulting from the detonation.
8. An engine as claimed in Claim 7, wherein there are a plurality of said cylinder and an equal plurality of said pistons, said pistons being commonly connected to a shaft and relatively offset in stroke timing to co-operate in driving the shaft.
9. An implosion pump comprising a combustion chamber interposed, and in communication with, an upper reservoir and a lower reservoir separated by a vertical distance across which water is to be pumped, said chamber receiving admixed hydrogen and oxygen at a pressure sufficient to lift a volume of water the distance therefrom to the top reservoir, said gas in the chamber then being combusted to create a vacuum in said chamber to draw water from said lower reservoir to fill said chamber, whereupon a pumping cycle is established and can be repeated.
10. An implosion pump as claimed in Claim 9, further comprising conduit means connecting a respective reservoir with said chamber and one-way flow valve means located in each conduit means to disallow reverse flow of water from said upper reservoir to said chamber and from said chamber to said lower reservoir.
11. A parallel stacked arrangement of cell plates for a water electrolysis unit, the cell plates alternately forming an anode and cathode of said electrolysis unit, and said arrangement including separate hydrogen gas and oxygen gas outlet port means respectively in communication with said anode cell plates and said cathode cell plates and extending longitudinally of said stacked plates, said stacked cell plates being configured in the region of said conduits to mate in a complementary manner to form said conduits such that a respective anode cell plate or cathode cell plate is insulated from the hydrogen gas conduit or the oxygen gas conduit.

12. An arrangement of cell plates as claimed in Claim 11, wherein said configuration is in the form of a flanged foot that extends to a flanged foot of the next adjacent like-type of anode or cathode cell plate respectively.

Henry Paine's HHO Fuel Conversion System

This is a very interesting patent which describes a simple system for overcoming the difficult problem of storing the hydrogen/oxygen gas mix produced by electrolysis of water. Normally this "hydroxy" gas mix is too dangerous to be compressed and stored like propane and butane are, but this patent states that hydroxy gas can be converted to a more benign form merely by bubbling it through a hydrocarbon liquid. Henry automatically speaks of turpentine in the patent, which strongly suggests that he used it himself, and consequently, it would probably be a good choice for any tests of the process.

This patent is more than 120 years old and has only recently been brought to the attention of the various "watercar" internet Groups. Consequently, it should be tested carefully before being used. Any tests should be done with extreme caution, taking every precaution against injury or damage should the mixture explode. It should be stressed that hydroxy gas is highly explosive, with a flame front speed far too fast to be contained by conventional commercial flashback arrestors. It is always essential to use a bubbler to contain any accidental ignition of the gas coming out of the electrolyser cell, as shown here:

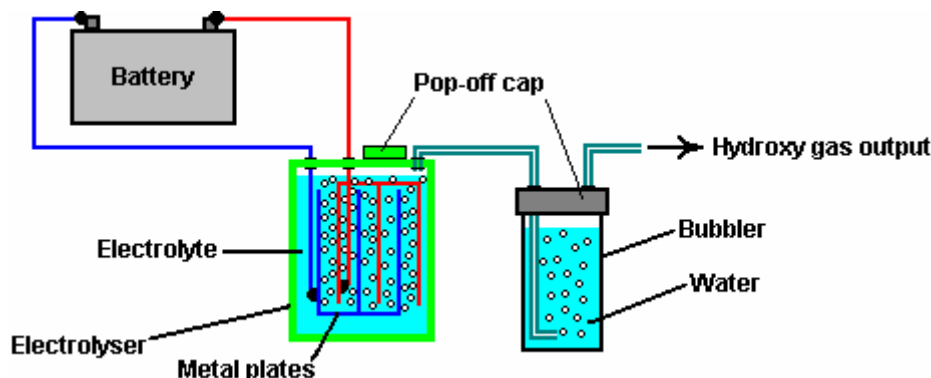

For the purposes of a test of the claims of this patent, it should be sufficient to fill the bubbler with turpentine rather than water, though if possible, it would be good to have an additional bubbler container for the turpentine, in which case, the bubbler with the water should come between the turpentine and the source of the flame. Any tests should be done in an open space, ignited remotely and the person running the test should be well protected behind a robust object. A disadvantage of hydroxy gas is that it requires a very small orifice in the nozzle used for maintaining a continuous flame and the flame temperature is very high indeed. If this patent is correct, then the modified gas produced by the process should be capable of being used in any conventional gas burner.

US Letters Patent 308,276

18th November 1884

Inventor: Henry M. Paine

PROCESS OF MANUFACTURING ILLUMINATING GAS

To all whom it may concern:

Be it known that I, Henry M. Paine, a citizen of the United States, residing at Newark, in the county of Essex and State of New Jersey, have invented certain new and useful Improvements in the Process of Manufacturing Illuminating-Gas; and I do hereby declare the following to be a full, clear, and exact description of the invention, such as will enable others skilled in the art to which it appertains, to make and use the same, reference being had to the accompanying drawing, and to letters or figures of reference marked thereon, which form a part of this specification.

The present invention relates to the processes for manufacturing illuminating-gas, as explained and set forth here. Up to now, it has always been found necessary to keep the constituent gases of water separated from each other from the point of production to the point of ignition, as hydrogen and oxygen being present in the proper proportions for a complete reunion, form a highly-explosive mixture. Consequently, the two gases have either been preserved in separate holders and only brought together at the point of ignition, or else the hydrogen alone has been saved and the oxygen to support combustion has been drawn from the open air, and the hydrogen gas thus obtained has been carburetted by itself by passing through a liquid hydrocarbon, which imparts luminosity to the flame.

I have discovered that the mixed gases obtained by the decomposition of water through electrolysis can be used with absolute safety if passed through a volatile hydrocarbon; and my invention consists of the new gas thus obtained, and the process described here for treating the gas mixture whereby it is rendered safe for use and storage under the same conditions as prevail in the use of ordinary coal-gas, and is transformed into a highly-luminiferous gas.

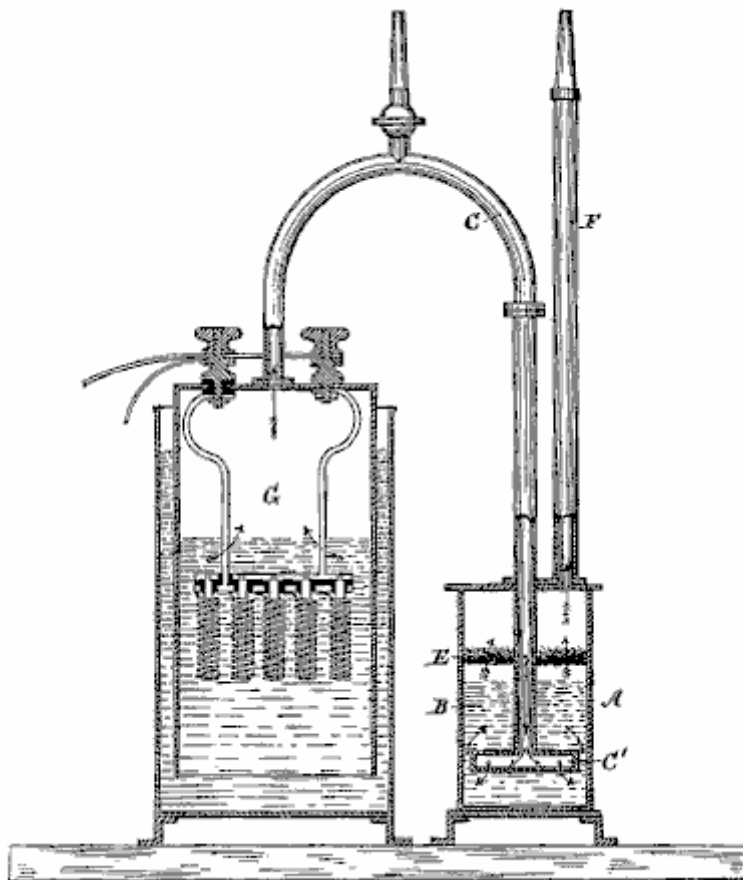

In the accompanying drawing, which shows in sectional elevation, an apparatus adapted to carry out my invention, **G** is a producer for generating the mixed gases, preferably by the decomposition of water by an electric current. **A** is a tank partly filled with turpentine, camphene or other hydrocarbon fluid as indicated by **B**. The two vessels are connected by the pipe **C**, the end of which terminates below the surface of the turpentine, and has a broad mouthpiece **C'**, with numerous small perforations, so that the gas rises through the turpentine in fine streams or bubbles in order that it may be brought intimately in contact with the hydrocarbon.

Above the surface of the turpentine there may be a diaphragm **E**, of wire netting or perforated sheet metal, and above this, a layer of wool or other fibre packed sufficiently tightly to catch all particles of the hydrocarbon fluid which may be mechanically held in suspension, but loose enough to allow free passage of the gases. The pipe **F**, conducts the mixed gases off directly to the burners or to a holder.

I am aware that the hydrocarbons have been used in the manufacture of water-gas from steam, and, as stated above, hydrogen gas alone has been carburetted; but I am not aware of any attempt being made to treat the explosive mixed gases in this manner.

Experiments have demonstrated that the amount of turpentine or other volatile hydrocarbon taken up by the gases in this process is very small and that the consumption of the hydrocarbon does not appear to bear any fixed ratio to the volume of the mixed gases passed through it. I do not, however, attempt to explain the action of the hydrocarbon on the gases.

What I claim as my invention and desire to secure by Letters Patent, is -

The process described here of manufacturing gas, which consists in decomposing water by electrolysis and conjointly passing the mixed constituent gases of water thus obtained, through a volatile hydrocarbon, substantially as and for the purpose set forth.

In testimony whereof I affix my signature in presence of two witnesses.

HENRY M. PAINE

Witnesses:
Bennet Osborne, Jr.,
W. E. Redding

Henry Paine's apparatus would therefor be:

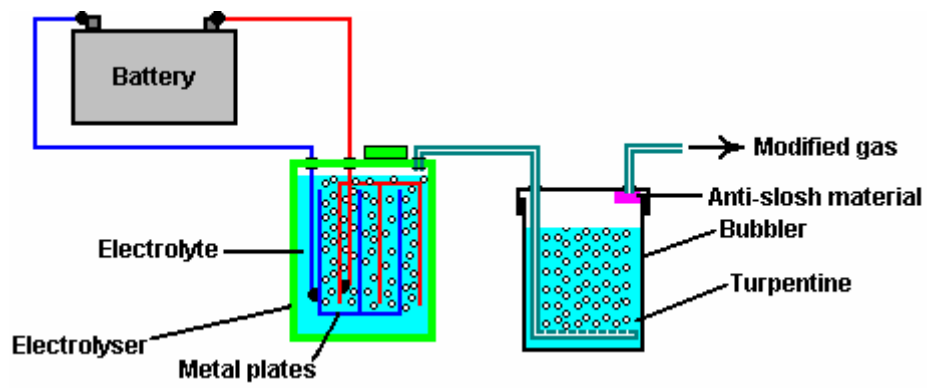

Boris Volfson's Space Drive

US Patent 6,960,975

Nov.1, 2005

Inventor: Boris Volfson

SPACE VEHICLE PROPELLED BY THE PRESSURE OF INFLATIONARY VACUUM STATE

ABSTRACT

A space vehicle propelled by the pressure of inflationary vacuum state is provided comprising a hollow superconductive shield, an inner shield, a power source, a support structure, upper and lower means for generating an electromagnetic field, and a flux modulation controller. A cooled hollow superconductive shield is energised by an electromagnetic field resulting in the quantised vortices of lattice ions projecting a gravitomagnetic field that forms a space-time curvature anomaly outside the space vehicle. The space-time curvature imbalance, the space-time curvature being the same as gravity, provides for the space vehicle's propulsion. The space vehicle, surrounded by the space-time anomaly, may move at a speed approaching the light-speed characteristic for the modified locale.

US Patent References:

3626605	Dec., 1971	Wallace.
3626606	Dec., 1971	Wallace.
3823570	Jul., 1974	Wallace.
5197279	Mar., 1993	Taylor.
6353311	Mar., 2002	Brainard et al.

Other References:

M.T. French, "To the Stars by Electromagnetic Propulsion", <http://www.mtjf.demon.co.uk/antigravp2.htm#cforce>.

Evgeny Podkletnov, "Weak Gravitational Shielding Properties of Composite Bulk $YBa_2Cu_3O_{(7-x)}$ Superconductor Below 70K Under E.M. Field", LANL database number cond-mat/9701074, v. 3, 10 pages, Sep. 16, 1997.

N. LI & D.G. Torr, "Effects of a Gravitomagnetic Field on Pure Superconductors", Physical Review, vol. 43, p. 457, 3 pages, Jan. 15, 1991.

Evgeny Podkletnov, Giovanni Modanese "Impulse Gravity Generator Based on Charged $YBa_2Cu_3O_{7-y}$ Superconductor with Composite Crystal Structure", arXiv.org/physics database, #0108005 vol. 2, 32 pages, 8 figures, Aug. 30, 2001.

S. Kopeikin & E. Fomalont, "General Relativistic Model for Experimental Measurement of the Speed of Propagation of Gravity by VLBI", Proceedings of the 6th European VLBI Network Symposium Jun. 25-28, 2002, Bonn, Germany, 4 pages.

Sean M. Carroll, "The Cosmological Constant", <http://pancake.uchicago.edu/~carroll/encycl/>, 6 pages.

Chris Y. Taylor and Giovanni Modanese, "Evaluation of an Impulse Gravity Generator Based Beamed Propulsion Concept", American Institute of Aeronautics and Astronautics, Inc., 2002.

Peter L. Skeggs, "Engineering Analysis of the Podkletnov Gravity Shielding Experiment", Quantum Forum, Nov. 7, 1997, <http://www.inetarena.com/~noetic/pls/podlev.html>).

BACKGROUND OF THE INVENTION

The existence of a magnetic-like gravitational field has been well established by physicists for general relativity, gravitational theories, and cosmology. The consequences of the effect of electromagnetically-affected gravity could be substantial and have many practical applications, particularly in aviation and space exploration.

There are methods known for converting electromagnetism into a propulsive force that potentially generates a large propulsive thrust. According to these methods, the machine thrust is produced by rotating, reciprocating masses in the following ways: centrifugal thrust, momentum thrust, and impulse thrust. ("To the Stars by Electromagnetic Propulsion", M. T. French, <http://www.mtjf.demon.co.uk/antigravp2.htm#cforce>).

However, the electromagnetic propulsion in an ambient space, or space that is not artificially modified, is not practical for interstellar travel because of the great distances involved. No interstellar travel is feasible without some form of distortion of space. In turn, no alteration of space is possible without the corresponding deformation of time. Gravitomagnetic alteration of space, resulting in the space-time curvature anomaly that could propel the space vehicle, could be a feasible approach to future space travel.

In the late 1940s, H. B. G. Casimir proved that the vacuum is neither particle nor field-free. It is a source of zero-point-fluctuation (ZPF) of fields such as the vacuum gravitomagnetic field. ZPF fields lead to real, measurable physical consequences such as the Casimir force. The quantised hand-made electromagnetic processes, such as those occurring in superconductors, affect the similarly quantised ZPFs. The most likely reason is the electron-positron creation and annihilation, in part corresponding to the "polarisation effect" cited by Evgeny Podkletnov in explaining the gravitomagnetic effect reportedly observed by him in 1992. ("Weak Gravitational Shielding Properties of Composite Bulk $\text{YBa}_2\text{Cu}_3\text{O}_{(7-x)}$ Superconductor Below 70 K Under E.M. Field", Evgeny Podkletnov, LANL database number cond-mat/9701074, v. 3, 10 pages, 16 Sep. 1997).

The investigation of gravitomagnetism, however, started well before Podkletnov. In the U.S. Pat. No. 3,626,605, Henry Wm. Wallace describes an experimental apparatus for generating and detecting a secondary gravitational field. He also shows how a time-varying gravitomagnetic field can be used to shield the primary background of a gravitoelectric field.

In the U.S. Pat. No. 3,626,606, Henry Wm. Wallace provides a variation of his earlier experiment. A type III-V semiconductor material, of which both components have unpaired nuclear spin, is used as an electronic detector for the gravitomagnetic field. The experiment demonstrates that the material in his gravitomagnetic field circuit has hysteresis and remanence effects analogous to magnetic materials.

In the U.S. Pat. No. 3,823,570, Henry Wm. Wallace provides an additional variation of his experiment. Wallace demonstrates that, by aligning the nuclear spin of materials having an odd number of nucleons, a change in specific heat occurs.

In the U.S. Pat. No. 5,197,279, James R. Taylor discloses Electromagnetic Propulsion Engine where solenoid windings generate an electromagnetic field that, without the conversion into a gravitomagnetic field, generates the thrust necessary for the propulsion.

In the U.S. Pat. No. 6,353,311 B1, John P. Brainard et al. offer a controversial theory of Universal Particle Flux Field, and in order to prove it empirically, provide a shaded motor-type device. This device is also intended for extracting energy from this hypothetical Field.

In the early 1980s, Sidney Coleman and F. de Luca noted that the Einsteinian postulate of a homogeneous Universe, while correct in general, ignores quantised local fluctuation of the pressure of inflationary vacuum state, this fluctuation causing local cosmic calamities. While the mass-less particles propagate through large portions of Universe at light speed, these anomaly bubbles, depending on their low or high relative vacuum density, cause a local increase or decrease of the propagation values for these particles. Scientists disagree about the possibility, and possible ways, to artificially create models of such anomalies.

In the early 1990s, Ning Li and D. G Torr described a method and means for converting an electromagnetic field into a gravitomagnetic field. Li and Torr suggested that, under the proper conditions, the minuscule force fields of superconducting atoms can "couple", compounding in strength to the point where they can produce a repulsion force ("Effects of a Gravitomagnetic Field on Pure Superconductors", N. Li and D. G. Torr, Physical Review, Volume 43, Page 457, 3 pages, 15 Jan. 1991).

A series of experiments, performed in the early 1990s by Podkletnov and R. Nieminen, reportedly resulted in a reduction of the weights of objects placed above a levitating, rotating superconductive disk subjected to high frequency magnetic fields. These results substantially support the expansion of Einsteinian physics offered by Li & Torr. Podkletnov and Giovanni Modanese have provided a number of interesting theories as to why the weight reduction effect could have occurred, citing quantum gravitational effects, specifically, a local change in the cosmological constant. The cosmological constant, under ordinary circumstances, is the same everywhere. But, according to Podkletnov and Modanese, above a levitating, rotating superconductive disk exposed to high frequency magnetic fields, it is modified. ("Impulse Gravity Generator Based on Charged $\text{YBa}_2\text{Cu}_3\text{O}_{7-y}$ Superconductor with Composite Crystal Structure", Evgeny Podkletnov, Giovanni Modanese, arXiv.org/physics database, #0108005 volume 2, 32 pages, 8 figures, Aug. 30, 2001).

In the July 2004 paper, Ning Wu hypothesised that exponential decay of the gravitation gauge field, characteristic for the unstable vacuum such as that created by Podkletnov and Nieminen, is at the root of the gravitational shielding effects (Gravitational Shielding Effects in Gauge Theory of Gravity, Ning Wu, arXiv:hep-th/0307225 v 1 23 Jul. 2003, 38 pages incl. 3 figures, July 2004).

In 2002, Edward Fomalont and Sergei Kopeikin measured the speed of propagation of gravity. They confirmed that the speed of propagation of gravity matches the speed of light. ("General Relativistic Model for Experimental Measurement of the Speed of Propagation of Gravity by VLBI", S. Kopeikin and E. Fomalont, Proceedings of the 6th European VLBI Network Symposium Jun. 25-28 2002, Bonn, Germany, 4 pages).

String theory unifies gravity with all other known forces. According to String theory, all interactions are carried by fundamental particles, and all particles are just tiny loops of space itself forming the space-time curvature. Gravity and bent space are the same thing, propagating with the speed of light characteristic of the particular curvature. In light of the Fomalont and Kopeikin discovery, one can conclude that if there is a change in the speed of propagation of gravity within the space-time curvature, then the speed of light within the locality would also be affected.

In general relativity, any form of energy affects the gravitational field, so the vacuum energy density becomes a potentially crucial ingredient. Traditionally, the vacuum is assumed to be the same everywhere in the Universe, so the vacuum energy density is a universal number. The cosmological constant Lambda is proportional to the vacuum pressure:

$$\rho_{\Lambda}: \Lambda = (8\pi G/3c^2)\rho_{\Lambda}$$

Where:

G is Newton's constant of gravitation and

c is the speed of light

("The Cosmological Constant", Sean M. Carroll, <http://pancake.uchicago.edu/~carroll/encyc/>, 6 pages). Newer theories, however, permit local vacuum fluctuations where even the "universal" constants are affected:

$$\Lambda_1 = (8\pi G_1/3c_1^2)\rho_{\Lambda_1}$$

Analysing physics laws defining the cosmological constant, a conclusion can be drawn that, if a levitating, rotating superconductive disk subjected to high frequency magnetic fields affects the cosmological constant within a locality, it would also affect the vacuum energy density. According to the general relativity theory, the gravitational attraction is explained as the result of the curvature of space-time being proportional to the cosmological constant. Thus, the change in the gravitational attraction of the vacuum's subatomic particles would cause a local anomaly in the curvature of the Einsteinean space-time.

Time is the fourth dimension. Lorentz and Einstein showed that space and time are intrinsically related. Later in his life, Einstein hypothesised that time fluctuates both locally and universally. Ruggero Santilli, recognised for expanding relativity theory, has developed the isocosmology theory, which allows for variable rates of time. Time is also a force field only detected at speeds above light speed. The energy of this force field grows as its propagation speed declines when approaching light-speed. Not just any light-speed: the light-speed of a locale. If the conditions of the locale were modified, this change would affect the local time rate relative to the rate outside the affected locale, or ambient rate. The electromagnetically-generated gravitomagnetic field could be one such locale modifier.

Analysing the expansion of Einsteinean physics offered by Li & Torr, one could conclude that gravity, time, and light speed could be altered by the application of electromagnetic force to a superconductor.

By creating a space-time curvature anomaly associated with lowered pressure of inflationary vacuum state around a space vehicle, with the lowest vacuum pressure density located directly in front of the vehicle, a condition could be created where gravity associated with lowered vacuum pressure density pulls the vehicle forward in modified space-time.

By creating a space-time curvature anomaly associated with elevated pressure of inflationary vacuum state around the space vehicle, with the point of highest vacuum pressure density located directly behind the vehicle, a condition could be created where a repulsion force associated with elevated vacuum pressure density pushes the space vehicle forward in modified space-time. From the above-mentioned cosmological constant equation, re-written as:

$$\rho_{\Lambda} = \frac{3c^2}{8\pi G} \Lambda$$

it is clear that the increase in the vacuum pressure density could lead to a substantial increase in the light-speed. If the space vehicle is moving in the anomaly where the local light-speed is higher than the light-speed of the ambient vacuum, and if this vehicle approaches this local light-speed, the space vehicle would then possibly exceed the light-speed characteristic for the ambient area.

The levitating and rotating superconductor disk, which Podkletnov used to protect the object of experiment from the attraction produced by the energy of the vacuum, was externally energised by the externally-powered solenoid

coils. Thus, Podkletnov's system is stationary by definition and not suitable for travel in air or space. Even if the superconductive disk is made part of the craft, and if it is energised by the energy available on the craft, the resulting anomaly is one-sided, not enveloping, and not providing the variable speed of light (VSL) environment for the craft.

In a recent (2002) article, Chris Y. Taylor and Modanese propose to employ an impulse gravity generator directing, from an outside location, an anomalous beam toward a spacecraft, this beam acting as a repulsion force field producing propulsion for the spacecraft. ("Evaluation of an Impulse Gravity Generator Based Beamed Propulsion Concept", Chris Y. Taylor and Giovanni Modanese, American Institute of Aeronautics and Astronautics, Inc., 2002, 21 pages, 10 figures). The authors of the article, however, didn't take into account the powerful quantised processes of field dispersion, which would greatly limit the distance of propagation of the repulsive force. At best, the implementation of this concept could assist in acceleration and deceleration at short distances from the impulse gravity generator, and only along a straight line of travel. If the travel goal is a space exploration mission rather than the shuttle-like commute, the proposed system is of little use.

Only a self-sufficient craft, equipped with the internal gravity generator and the internal energy source powering this generator, would have the flexibility needed to explore new frontiers of space. The modification of the space-time curvature all around the spacecraft would allow the spacecraft to approach the light-speed characteristic for the modified locale, this light-speed, when observed from a location in the ambient space, being potentially many times higher than the ambient light-speed. Then, under sufficient local energies, that is, energies available on the spacecraft, very large intergalactic distances could be reduced to conventional planetary distances.

In "The First Men in the Moon" (1903), H. G. Wells anticipates gravitational propulsion methods when he describes gravity repelling "cavorite." Discovered by Professor Cavor, the material acts as a "gravity shield" allowing Cavor's vehicle to reach the Moon. Prof. Cavor built a large spherical gondola surrounded on all sides by cavorite shutters that could be closed or opened. When Prof. Cavor closed all the shutters facing the ground and opened the shutters facing the moon, the gondola took off for the Moon.

Until today, no cavorite has been discovered. However, recent research in the area of superconductivity, nano materials and quantum state of vacuum, including that of Li, Torr, Podkletnov, and Modanese, has resulted in important new information about the interaction between a gravitational field and special states of matter at a quantum level. This new research opens the possibility of using new electromagnetically-energised superconductive materials allowing stable states of energy, the materials useful not only in controlling the local gravitational fields, but also in creating new gravitomagnetic fields.

BACKGROUND OF INVENTION: OBJECTS AND ADVANTAGES

There are four objects of this invention:

The first object is to provide a method for generating a pressure anomaly of inflationary vacuum state that leads to electromagnetic propulsion.

The second object is to provide a space vehicle capable of electromagnetically-generated propulsion. The implementation of these two objects leads to the development of the space vehicle propelled by gravitational imbalance with gravity pulling, and/or antigravity pushing, the space vehicle forward.

The third object is to provide a method for generating a pressure anomaly of inflationary vacuum state, specifically, the local increase in the level of vacuum pressure density associated with the greater curvature of space-time. The speed of light in such an anomaly would be higher than the speed of light in the ambient space.

The fourth object is to provide the space vehicle capable of generating an unequally-distributed external anomaly all around this vehicle, specifically the anomaly with the elevated level of vacuum pressure density. The anomaly is formed in such a way that gravity pulls the space vehicle forward in the modified space-time at a speed possibly approaching the light-speed specific for this modified locale. If the vacuum pressure density of the locale is modified to be substantially higher than that of the ambient vacuum, the speed of the vehicle could conceivably be higher than the ambient light-speed.

SUMMARY OF THE INVENTION

This invention concerns devices self-propelled by the artificially changed properties of the pressure of inflationary vacuum state to speeds possibly approaching the light-speed specific for this modified locale. Furthermore, this invention concerns devices capable of generating the space-time anomaly characterised by the elevated vacuum

pressure density. The devices combining these capabilities may be able to move at speeds substantially higher than the light-speed in the ambient space.

The device of this invention is a space vehicle. The outside shell of the space vehicle is formed by a hollow disk, sphere, or the like hollowed 3-dimensional shape made of a superconductor material, hereinafter a hollow superconductive shield. An inner shield is disposed inside the hollow superconductive shield. The inner shield is provided to protect crew and life-support equipment inside.

A support structure, upper means for generating an electromagnetic field and lower means for generating an electromagnetic field are disposed between the hollow superconductive shield and the inner shield. A flux modulation controller is disposed inside the inner shield to be accessible to the crew.

Electrical energy is generated in a power source disposed inside the hollow superconductive shield. The electrical energy is converted into an electromagnetic field in the upper means for generating an electromagnetic field and the lower means for generating an electromagnetic field.

Electrical motors, also disposed inside the hollow superconductive shield, convert the electrical energy into mechanical energy.

The mechanical energy and the electromagnetic field rotate the hollow superconductive shield, and the upper and the lower means for generating an electromagnetic field, against each other.

The electromagnetic field is converted into a gravitomagnetic field in the hollow superconductive shield.

The gravitomagnetic field, propagated outward, orthogonally to the walls of the hollow superconductive shield, forms a pressure anomaly of inflationary vacuum state in the area of propagation. The pressure anomaly of inflationary vacuum state is comprised of an area of relatively lower vacuum pressure density in front of the space vehicle and an area of relatively higher vacuum pressure density behind the vehicle.

The difference in the vacuum pressure density propels the space vehicle of this invention forward.

BRIEF DESCRIPTION OF THE DRAWINGS

Fig.1 is a cross-sectional view through the front plane taken along the central axis of a space vehicle provided by the method and device of this invention.

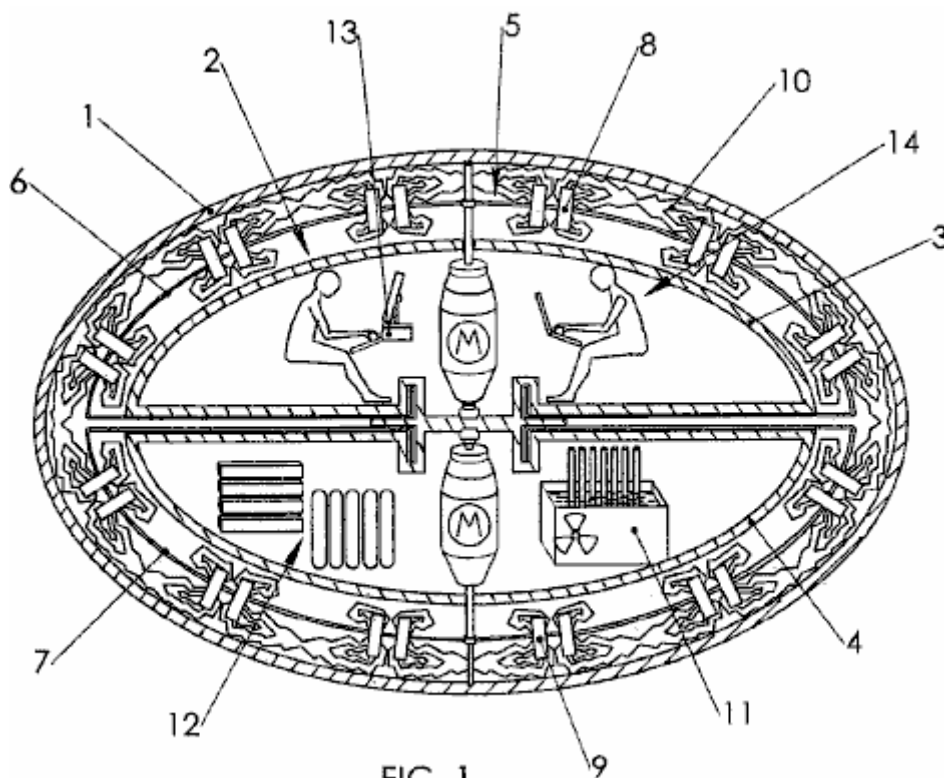

Fig.2A and **Fig.2B** are diagrams, presented as perspective views, showing some of the physical processes resulting from a dynamic application of an electromagnetic field to a hollow superconductive shield. Only one line of quantised vortices, shown out of scale, is presented for illustration purposes.

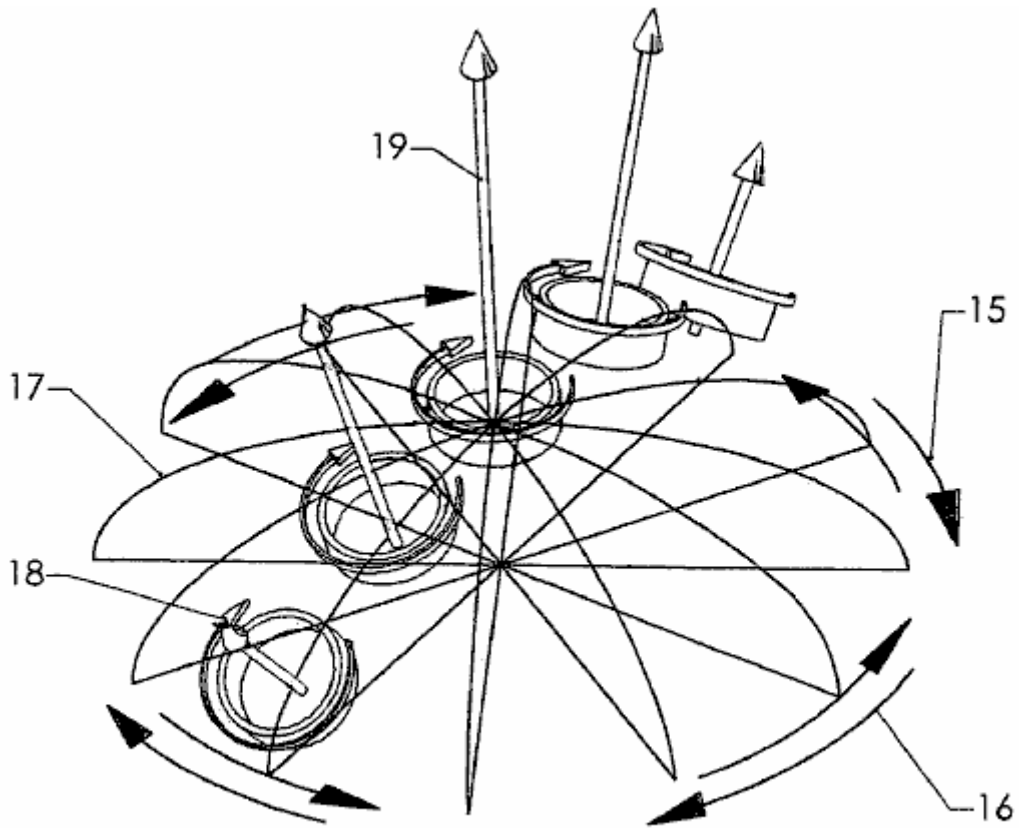

FIG. 2A

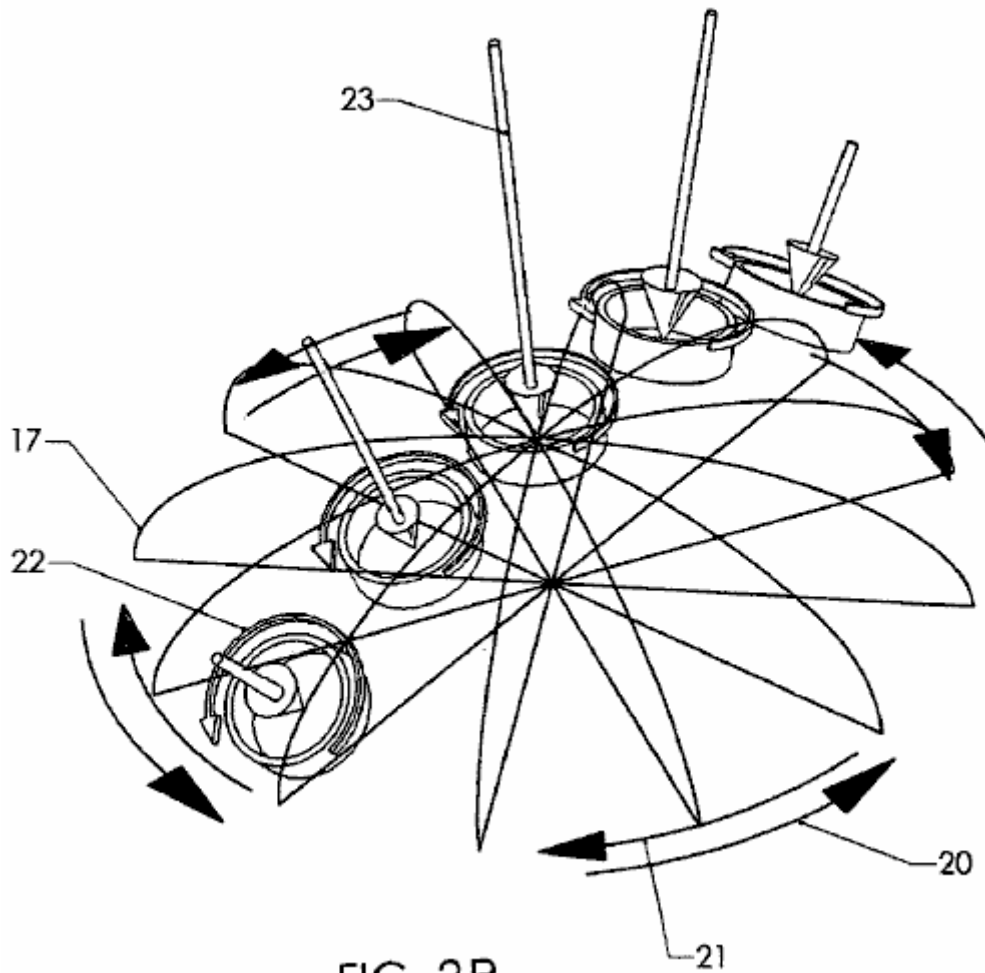

FIG. 2B

Fig.3A and **Fig.3B** are diagrams, presented as perspective views, showing a vacuum pressure density anomaly associated with lowered pressure of inflationary vacuum state and a vacuum pressure density anomaly associated with elevated pressure of inflationary vacuum state, respectively. Both anomalies are shown on the background of Universal curvature of inflationary vacuum state.

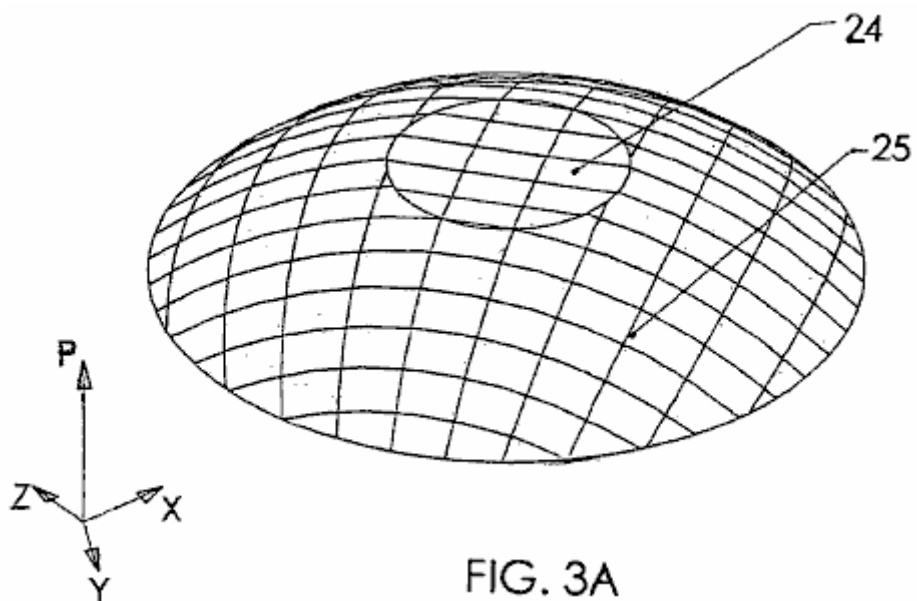

FIG. 3A

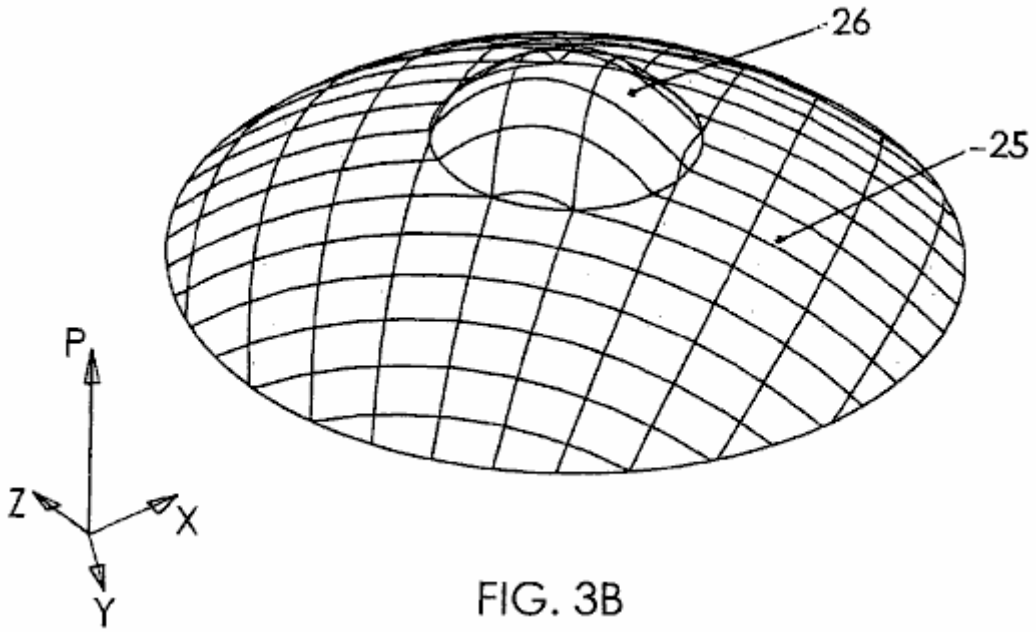
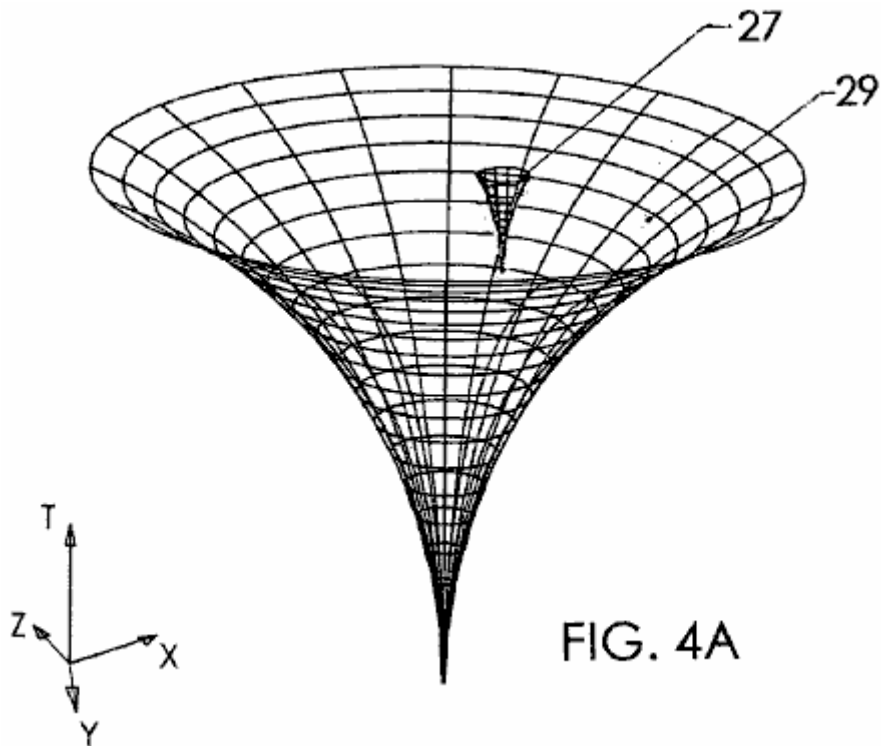

Fig.4A and **Fig.4B** are diagrams, presented as perspective views, showing a space-time anomaly associated with lowered pressure of inflationary vacuum state and a space-time anomaly associated with elevated pressure of inflationary vacuum state, respectively. Both anomalies are shown on the background of Universal space-time.



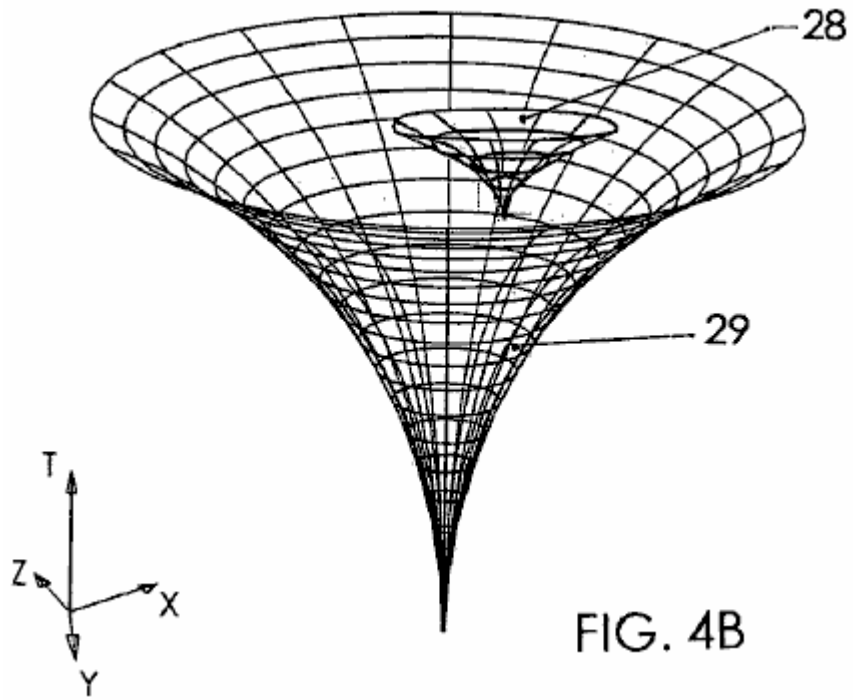

FIG. 4B

Figs.5A, 5B, 6, 7A, & 7B are diagrams of space-time curvature anomalies generated by the space vehicle of the current invention, these anomalies providing for the propulsion of the space vehicle.

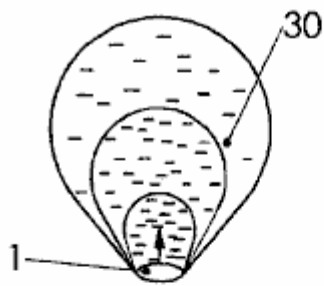

FIG.5A

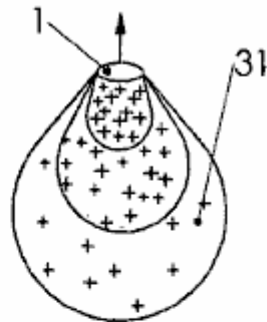

FIG.5B

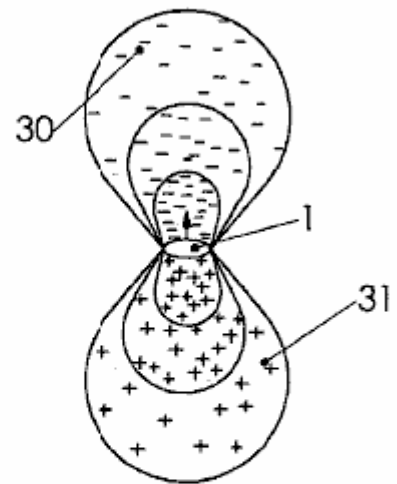

FIG.6

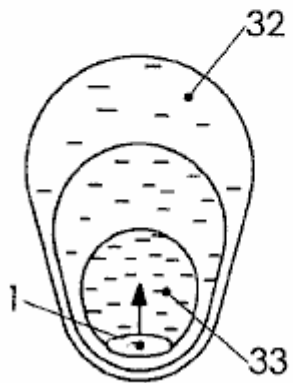

FIG.7A

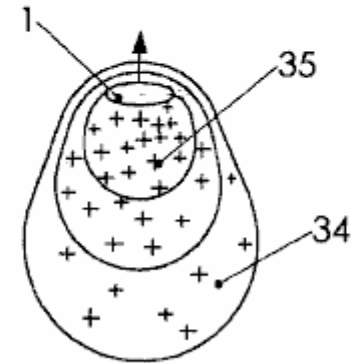

FIG.7B

DRAWINGS—REFERENCE NUMERALS

- #1 hollow superconductive shield
- #2 inner shield
- #3 upper shell
- #4 lower shell
- #5 support structure
- #6 upper rotating element
- #7 lower rotating element
- #8 upper means for generating an electromagnetic field
- #9 lower means for generating an electromagnetic field
- #10 flux lines
- #11 power source
- #12 life-support equipment
- #13 flux modulation controller
- #14 crew
- #15 clockwise shield motion vector
- #16 counter-clockwise EMF motion vector
- #17 wire grid
- #18 clockwise quantised vortices of lattice ions
- #19 outward gravitomagnetic field vector
- #20 counter-clockwise shield motion vector
- #21 clockwise EMF motion vector
- #22 counter-clockwise quantised vortices of lattice ions
- #23 inward gravitomagnetic field vector
- #24 vacuum pressure density anomaly associated with lowered pressure of inflationary vacuum state
- #25 Universal curvature of inflationary vacuum state
- #26 vacuum pressure density anomaly associated with elevated pressure of inflationary vacuum state
- #27 space-time anomaly associated with lowered pressure of inflationary vacuum state
- #28 space-time anomaly associated with elevated pressure of inflationary vacuum state
- #29 Universal space-time
- #30 substantially droplet-shaped space-time curvature anomaly associated with lowered pressure of inflationary vacuum state
- #31 substantially droplet-shaped space-time anomaly associated with elevated pressure of inflationary vacuum state
- #32 substantially egg-shaped space-time anomaly associated with lowered pressure of inflationary vacuum state
- #33 area of the lowest vacuum pressure density
- #34 substantially egg-shaped space-time anomaly associated with elevated pressure of inflationary vacuum state
- #35 area of the highest vacuum pressure density

DESCRIPTION OF THE PRESENTLY PREFERRED EMBODIMENT

Fig.1 is a cross-sectional view through the front plane taken along the central axis of a space vehicle provided by the method and device of this invention. A hollow superconductive shield 1 forms a protective outer shell of the space vehicle. The hollow superconductive shield 1 may be shaped as a hollow disk, sphere, or the like 3-dimensional geometrical figure formed by the 2-dimensional rotation of a curve around the central axis.

In the preferred embodiment, the hollow superconductive shield 1 is made of a superconductor such as $\text{YBa}_2\text{Cu}_3\text{O}_{7-y}$, or a like high-temperature superconductor with a composite crystal structure cooled to the temperature of about 40^0K . Those skilled in the art may envision the use of many other low and high temperature superconductors, all within the scope of this invention.

An inner shield 2 is disposed inside the hollow superconductive shield 1. The inner shield 2 is comprised of an upper shell 3 and a lower shell 4, the shells 3 and 4 adjoined with each other. Executed from insulation materials such as foamed ceramics, the inner shield 2 protects the environment within the shield from the electromagnetic field and severe temperatures.

A support structure 5 is disposed between the hollow superconductive shield 1 and the inner shield 2, concentric to the hollow superconductive shield. The support structure 5 is comprised of an upper rotating element 6 and a lower rotating element 7.

The upper rotating element 6 is pivotably disposed inside the hollow superconductive shield 1 and may envelope the upper shell 3. The lower rotating element 7 is pivotably disposed inside the hollow superconductive shield 1

and may envelope the lower shell **4**. Even though the preferred embodiment has two rotating elements, those skilled in the art may envision only one rotating element, or three or more rotation elements, all within the scope of this invention.

Upper means for generating an electromagnetic field **8** are disposed between the hollow superconductive shield **1** and the upper shell **3**. The upper means for generating an electromagnetic field **8** are fixed to the upper rotating element **6** at an electromagnetic field-penetrable distance to the hollow superconductive shield **1**.

Lower means for generating an electromagnetic field **9** are disposed between the hollow superconductive shield **1** and the lower shell **4**. The lower means for generating an electromagnetic field **9** are fixed to the lower rotating element **7** at an electromagnetic field-penetrable distance to the hollow superconductive shield **1**.

The upper means for generating an electromagnetic field **8** and the lower means for generating an electromagnetic field **9** could be solenoid coils or electromagnets. In the process of operation of the space vehicle, the electromagnetic field identified by flux lines **10**, is controllably and variably applied to the hollow superconductive shield **1**.

Electric motors are disposed inside the hollow superconductive shield along its central axis.

A power source **11** is disposed inside the hollow superconductive shield **1** and may be disposed inside the lower shell **4**. The power source **11** is electrically connected with the upper means for generating an electromagnetic field **8**, the lower means for generating an electromagnetic field **9**, and the electric motors. The upper means for generating an electromagnetic field **8**, the lower means for generating an electromagnetic field **9**, and the electric motors provide for the rotation of the upper rotating element **6** and the lower rotating element **7**. The power source **11** may be a nuclear power generator.

Life-support equipment **12** is disposed inside the inner shield **2**, and may be disposed inside the lower shell **4**. The life-support equipment **12** may include oxygen, water, and food.

A flux modulation controller **13** is disposed inside the inner shield **2**, and may be disposed inside the upper shell **3**. The flux modulation controller **13** is in communication with the upper means for generating an electromagnetic field **8**, the lower means for generating an electromagnetic field **9**, the power source **11**, and the electric motors.

The flux modulation controller **8** may be executed as a computer or a microprocessor. The flux modulation controller **8** is provided with a capability of modulating the performance parameters of the upper means for generating an electromagnetic field **8**, the lower means for generating an electromagnetic field **9**, the power source **11**, and the electric motors.

A crew **14** may be located inside the upper shell **3** of the inner shield **2** and may consist of one or more astronauts. The crew has a free access to the life-support equipment **12** and the flux modulation controller **8**. A person skilled in the art, may envision a fully-automated, pilotless craft, which is also within the scope of this invention.

A person skilled in the art, may also envision the embodiment (not shown), also within the scope of this invention, where the hollow superconductive shield is pivotable, and the support structure with the means for generating an electromagnetic field is affixed on the outside of the inner shield.

Fig.2A and **Fig.2B** are diagrams showing the results of the quantised electromagnetic turbulence within the superconductive shell of the hollow superconductive shield provided by the relative rotational motion of the hollow superconductive shield against the upper means for generating an electromagnetic field.

Fig.2A shows the clockwise relative rotational motion of the hollow superconductive shield, this motion identified by a clockwise shield motion vector **15**, and the counter-clockwise relative rotational motion of upper means for generating an electromagnetic field, this motion identified by a counter-clockwise EMF motion vector **16**.

The electromagnetic field, controllably and variably applied by the upper means for generating an electromagnetic field, whose various positions are identified by a wire grid **17**, to the hollow superconductive shield (not shown), causes quantised electromagnetic turbulence within the hollow superconductive shield. This turbulence is represented by a plurality of clockwise quantised vortices of lattice ions **18**. Only one line of the clockwise quantised vortices of lattice ions **18**, (not to scale), is shown for illustration purposes only. Each of the clockwise quantised vortices of lattice ions **18** generates a gravitomagnetic field identified by an outward gravitomagnetic field vector **19** directed orthogonally away from the hollow superconductive shield.

Fig.2B shows the counter-clockwise relative rotational motion of the hollow superconductive shield, this motion identified by a counter-clockwise shield motion vector **20**, and the clockwise relative rotational motion of upper means for generating an electromagnetic field, this motion identified by a clockwise EMF motion vector **21**.

The electromagnetic field, controllably and variably applied by the upper means for generating an electromagnetic field identified by the wire grid **17**, to the hollow superconductive shield (not shown), causes quantised electromagnetic turbulence within the hollow superconductive shield, this turbulence represented by a plurality of counter-clockwise quantised vortices of lattice ions **22**. Only one line of the counter-clockwise quantised vortices of lattice ions **22**, (not to scale), is shown for illustration purposes only. Each of the counter-clockwise quantised vortices of lattice ions **22** generates a gravitomagnetic field identified by an inward gravitomagnetic field vector **23** directed orthogonally toward the hollow superconductive shield.

The electrical requirements for providing the Li-Torr effect are as follows:

Podkletnov has reported using the high frequency current of 105 Hz. He also used 6 solenoid coils @ 850 Gauss each. The reported system's efficiency reached 100% and the total field in the Podkletnov's disk was about 0.5 Tesla. The maximum weight loss reported by Podkletnov was 2.1%.

The preferred embodiment of the device of current invention is capable of housing 2-3 astronauts and therefore is envisioned to be about 5 meters in diameter at the widest point. The preferred space vehicle's acceleration is set at 9.8 m/s/s providing that gravity on board is similar to that on the surface of Earth.

The means for generating an electromagnetic field may be comprised of 124 solenoid coils. At the same 100% efficiency reported by Podkletnov, the total field required providing the acceleration of 9.8 m/s/s is 5,000 Tesla, or about 40 Tesla per coil. Skeggs suggests that on the Podkletnov device, out of 850 Gauss developed on the coil surface, the field affecting the superconductor and causing the gravitomagnetism is only 400 Gauss ("Engineering Analysis of the Podkletnov Gravity Shielding Experiment, Peter L. Skeggs, Quantum Forum, Nov. 7, 1997, <http://www.inetarena.com/~noetic/pls/podlev.html>, 7 pages). This translates into 47% device efficiency.

In this 47%-efficient space vehicle, the total field required achieving the 9.8 m/s/s acceleration is about 10,600 Tesla, or 85.5 Tesla per each of 124 solenoid coils. It must be noted that at this acceleration rate, it would take nearly a year for the space vehicle to reach the speed of light.

It also must be noted that Skeggs has detected a discrepancy between the Li-Torr estimates and Podkletnov's practical results. If Podkletnov's experimental results are erroneous while the Li-Torr estimates are indeed applicable to the space vehicle of this invention, then the energy requirements for achieving the sought speed would be substantially higher than the above estimate of 10,600 Tesla.

Podkletnov has concluded that, in order for the vacuum pressure density anomaly to take place, the Earth-bound device must be in the condition of Meissner levitation. As are all space bodies, the space vehicle is a subject to the pressure inflationary vacuum state and the gravitational force, which, within the migrating locality of the expanding Universe, in any single linear direction, are substantially in equilibrium. Thus, for the space vehicle, the requirement of Meissner levitation is waved.

The propagation of the gravitomagnetic field identified by the outward gravitomagnetic field vector **19** and the inward gravitomagnetic field vector **23** would cause exotic quantised processes in the vacuum's subatomic particles that include particle polarisation, ZPF field defects, and the matter-energy transformation per $E=mc^2$. The combination of these processes would result in the gravitational anomaly. According to the general relativity theory, gravitational attraction is explained as the result of the curvature of space-time being proportional to the gravitational constant. Thus, the change in the gravitational attraction of the vacuum's subatomic particles would cause a local anomaly in the curvature of the Einsteinean space-time.

Gravity is the same thing as bent space, propagating with the speed of light characteristic for the particular space-time curvature. When bent space is affected, there is a change in the speed of propagation of gravity within the space-time curvature anomaly. The local speed of light, according to Fomalont and Kopeikin always equal to the local speed of propagation of gravity, is also affected within the locality of space-time curvature anomaly.

Creation of space-time curvature anomalies adjacent to, or around, the space vehicle, these anomalies characterised by the local gravity and light-speed change, has been the main object of this invention.

Fig.3A shows a diagram of a vacuum pressure density anomaly associated with lowered pressure of inflationary vacuum state **24** on the background of Universal curvature of inflationary vacuum state **25**. The vacuum pressure density anomaly associated with lowered pressure of inflationary vacuum state **24** is formed by a multitude of the inward gravitomagnetic field vectors. According to the cosmological constant equation,

$$\rho_{\Lambda}: \Lambda = (8\pi G/3c^2)\rho_{\Lambda}$$

where:

The cosmological constant Lambda, is proportional to the vacuum energy pressure rho-lambda, G is Newton's constant of gravitation, and c is the speed of light, so the curvature of space-time is proportional to the gravitational constant. According to the general relativity theory, the change in the vacuum pressure density is proportional to the change in the space-time curvature anomaly. By replacing rho-lambda with the vacuum pressure density, P times the vacuum energy coefficient kappa, and replacing c with: delta-distance/delta-time, we derive to the equation:

$$\Lambda = [8\pi G/3(\Delta\text{distance}/\Delta\text{time})^2]P_{\kappa}$$

and can now construct a vacuum pressure density curvature diagram.

The vacuum pressure density curvature anomaly associated with lowered pressure of inflationary vacuum state **24** is shown here as a flattened surface representing the lowered pressure of the inflationary vacuum state. This anomaly is the result of the exotic quantised processes in the subatomic particles caused by the quantised turbulence occurring in the hollow superconductive shield. The XYZ axes represent three dimensions of space and the P axis represents the vacuum pressure density.

Fig.3B shows a diagram of a vacuum pressure density anomaly associated with elevated pressure of inflationary vacuum state **26** on the background of the Universal curvature of inflationary vacuum state **25**. The vacuum pressure density anomaly associated with elevated pressure of inflationary vacuum state **26** is formed by a multitude of the outward gravitomagnetic field vectors. The anomaly is shown here as a convex surface representing the elevated pressure of inflationary vacuum state. The diagrams of **Fig.3A** and **Fig.3B** are not to scale with the anomaly sizes being exaggerated for clarity.

Fig.4A and **Fig.4B** show diagrams of a space-time anomaly associated with lowered pressure of inflationary vacuum state **27**, and a space-time anomaly associated with elevated pressure of inflationary vacuum state **28**, respectively, each on the background a diagram of Universal space-time **29**.

The quaterised Julia set $Q_{n+1} = Q_n^2 + C_0$ is assumed to be an accurate mathematical representation of the Universal space-time. The generic quaternion Q_0 belongs to the Julia set associated with the quaternion C, and n tends to infinity. If we assume that the quaternion value C_0 is associated with the Universal space-time **29**, C_1 is the value of quaternion C for the space-time anomaly associated with lowered pressure of inflationary vacuum state **27**, and C_2 is the value of quaternion C for the space-time anomaly associated with elevated pressure of inflationary vacuum state **28**, then we can construct two diagrams.

The diagram of **Fig.4A** shows the space-time anomaly associated with lowered pressure of inflationary vacuum state **27** as a quaterised Julia set contained in a 4-dimensional space: $Q_{n+1} = Q_n^2 + C_1$ on the background of the Universal space-time **29** represented by $Q_{n+1} = Q_n^2 + C_0$.

The diagram of **Fig.4B** shows the space-time anomaly associated with elevated pressure of inflationary vacuum state **28** as a quaterised Julia set $Q_{n+1} = Q_n^2 + C_2$, also on the background of the Universal space-time **29** represented by $Q_{n+1} = Q_n^2 + C_0$. On both diagrams, the XYZ axes represent three dimensions of space, and the T axis represents time. The diagrams are not to scale: the anomaly sizes are exaggerated for clarity, and the halves of quaterised Julia sets, conventionally associated with the hypothetical Anti-Universe, are omitted.

Figs. 5A, 5B, 6, 7A, & 7B show simplified diagrams of space-time curvature anomalies generated by the space vehicle of the current invention, these anomalies providing for the propulsion of the space vehicle. In each case, the pressure anomaly of inflationary vacuum state is comprised of an area of relatively lower vacuum pressure density in front of the space vehicle and an area of relatively higher vacuum pressure density behind the space vehicle. Because the lower pressure of inflationary vacuum state is associated with greater gravity and the higher pressure is associated with the higher repulsive force, the space vehicle is urged to move from the area of relatively higher vacuum pressure density toward the area of relatively lower vacuum pressure density.

Fig.5A illustrates the first example of space-time curvature modification. This example shows a substantially droplet-shaped space-time curvature anomaly associated with lowered pressure of inflationary vacuum state **30** adjacent to the hollow superconductive shield **1** of the space vehicle. The anomaly **30** is provided by the propagation of a gravitomagnetic field radiating orthogonally away from the front of the hollow superconductive shield **1**. This gravitomagnetic field may be provided by the relative clockwise motion of the upper means for generating an electromagnetic field, and relative counterclockwise motion of the hollow superconductive field, as observed from above the space vehicle.

In this example, the difference between the space-time curvature within the substantially droplet-shaped space-time anomaly associated with lowered pressure of inflationary vacuum state, and the ambient space-time curvature, the space-time curvature being the same as gravity, results in the gravitational imbalance, with gravity pulling the space vehicle forward.

Fig.5B illustrates the second example of space-time curvature modification. This example shows a substantially droplet-shaped space-time anomaly associated with elevated pressure of inflationary vacuum state **31** adjacent to the hollow superconductive shield **1** of the space vehicle. The anomaly **31** is provided by the propagation of a gravitomagnetic field radiating orthogonally away from the back of the hollow superconductive shield. This gravitomagnetic field may be provided by the relative counter-clockwise motion of the lower means for generating an electromagnetic field, and relative clockwise motion of the hollow superconductive field, as observed from below the space vehicle.

In this example, the difference between the space-time curvature within the substantially droplet-shaped space-time anomaly associated with elevated pressure of inflationary vacuum state, and the ambient space-time curvature, the space-time curvature being the same as gravity, results in the gravitational imbalance, with the repulsion force pushing the space vehicle forward.

Fig.6 illustrates the third example of space-time curvature modification. This example shows the formation of the substantially droplet-shaped space-time anomaly associated with lowered pressure of inflationary vacuum state **30** combined with the substantially droplet-shaped space-time anomaly associated with elevated pressure of inflationary vacuum state **31**. This combination of anomalies may be provided by the relative clockwise motion of the upper means for generating an electromagnetic field and relative clockwise motion of the hollow superconductive field, combined with the relative clockwise motion of the lower means for generating an electromagnetic field, as observed from above the space vehicle.

In this example, the difference between the space-time curvature within the substantially droplet-shaped space-time anomaly associated with lowered pressure of inflationary vacuum state, and the space-time curvature of the substantially droplet-shaped space-time anomaly associated with elevated pressure of inflationary vacuum state, the space-time curvature being the same as gravity, results in the gravitational imbalance, with gravity pulling, and the repulsion force pushing, the space vehicle forward.

Fig.7A illustrates the fourth example of space-time curvature modification. This example shows the formation of a substantially egg-shaped space-time anomaly associated with lowered pressure of inflationary vacuum state **32** around the hollow superconductive shield **1** of the space vehicle. The anomaly **32** is provided by the propagation of gravitomagnetic field of unequally-distributed density, this gravitomagnetic field radiating in all directions orthogonally away from the hollow superconductive shield. The propagation of the unequally-distributed gravitomagnetic field leads to the similarly unequally-distributed space-time curvature anomaly. This unequally-distributed gravitomagnetic field may be provided by the relatively faster clockwise motion of the upper means for generating an electromagnetic field relative to the hollow superconductive field, combined with the relatively slower counter-clockwise motion of the lower means for generating an electromagnetic field, as observed from above the space vehicle.

An area of the lowest vacuum pressure density **33** of the substantially egg-shaped space-time anomaly associated with lowered pressure of inflationary vacuum state **32** is located directly in front of the space vehicle.

In this example, the variation in the space-time curvature within the substantially egg-shaped space-time anomaly associated with lowered pressure of inflationary vacuum state, the space-time curvature being the same as gravity, results in a gravitational imbalance, with gravity pulling the space vehicle forward in modified space-time.

Fig.7B illustrates the fifth example of space-time curvature modification, also with the purpose of providing for a propulsion in modified space-time. This example shows the formation of a substantially egg-shaped space-time anomaly associated with elevated pressure of inflationary vacuum state **34** around the hollow superconductive shield **1** of the space vehicle. The anomaly **34** is provided by the propagation of gravitomagnetic field of unequally-distributed density, this gravitomagnetic field radiating in all directions orthogonally away from the hollow superconductive shield. The propagation of the unequally-distributed gravitomagnetic field leads to the similarly unequally-distributed space-time curvature anomaly. This unequally-distributed gravitomagnetic field may be provided by the relatively slower counter-clockwise motion of the upper means for generating an electromagnetic field relative to the hollow superconductive field, combined with the relatively faster clockwise motion of the lower means for generating an electromagnetic field, as observed from above the space vehicle.

An area of the highest vacuum pressure density **35** of the substantially egg-shaped space-time anomaly associated with elevated pressure of inflationary vacuum state **34** is located directly behind the space vehicle.

In this example, the variation in the space-time curvature within the substantially egg-shaped space-time anomaly associated with elevated pressure of inflationary vacuum state, the space-time curvature being same as gravity, results in a gravitational imbalance, with the repulsion force pushing the space vehicle forward in modified space-time at speeds approaching the light-speed characteristic for this modified area. This light-speed might be much higher than the light-speed in the ambient space.

By creating alternative anomalies and modulating their parameters, the space vehicle's crew would dilate and contract time and space on demand. The space vehicle, emitting a vacuum pressure modifying, controllably-modulated gravitomagnetic field in all directions, would rapidly move in the uneven space-time anomaly it created, pulled forward by gravity or pushed by the repulsion force. The time rate zone of the anomaly is expected to have multiple quantised boundaries rather than a single sudden boundary affecting space and time in the immediate proximity of the vehicle. Speed, rate of time, and direction in space could be shifted on demand and in a rapid manner. The modulated light-speed could make the space vehicle suitable for interstellar travel. Because of the time rate control in the newly created isospace, the accelerations would be gradual and the angles of deviation would be relatively smooth. The gravity shielding would further protect pilots from the ill-effects of gravity during rapid accelerations, directional changes, and sudden stops.

If you find the thought of generating a gravitational field, difficult to come to terms with, then consider the work of Henry Wallace who was an engineer at General Electric about 25 years ago, and who developed some incredible inventions relating to the underlying physics of the gravitational field. Few people have heard of him or his work. Wallace discovered that a force field, similar or related to the gravitational field, results from the interaction of relatively moving masses. He built machines which demonstrated that this field could be generated by spinning masses of elemental material having an odd number of nucleons -- i.e. a nucleus having a multiple half-integral value of \hbar , the quantum of angular momentum. Wallace used bismuth or copper material for his rotating bodies and "kinnemassic" field concentrators.

Aside from the immense benefits to humanity which could result from a better understanding of the physical nature of gravity, and other fundamental forces, Wallace's inventions could have enormous practical value in countering gravity or converting gravitational force fields into energy for doing useful work. So, why has no one heard of him? One might think that the discoverer of important knowledge such as this would be heralded as a great scientist and nominated for dynamite prizes. Could it be that his invention does not work? Anyone can get the patents. Study them -- Wallace -- General Electric -- detailed descriptions of operations -- measurements of effects -- drawings and models -- it is authentic. If you are handy with tools, then you can even build it yourself. It does work.

Henry was granted two patents in this field:

US Patent #3626605 -- "Method and Apparatus for Generating a Secondary Gravitational Force Field", Dec 14, 1971 and

US Patent #3626606 -- "Method and Apparatus for Generating a Dynamic Force Field", Dec 14, 1971. He was also granted US Patent #3823570 -- "Heat Pump" (based on technology similar to the above two inventions), July 16, 1973.

These patents can be accessed via <http://www.freepatentsonline.com>

The First High MPG Carburettor of Charles Pogue

US Patent 642,434

12th November 1932

Inventor: Charles N. Pogue

CARBURETTOR

This patent describes a carburettor design which was able to produce very high mpg figures using the gasoline available in the USA in the 1930s but which is no longer available as the oil industry does not want functional high mpg carburettors to be available to the public.

DESCRIPTION

This invention relates to a device for obtaining an intimate contact between a liquid in a vaporous state and a gas, and particularly to such a device which may serve as a carburettor for internal combustion engines.

Carburettors commonly used for supplying a combustible mixture of air and liquid fuel to internal combustion engines, comprise a bowl in which a supply of the fuel is maintained in the liquid phase and a fuel jet which extends from the liquid fuel into a passage through which air is drawn by the suction of the engine cylinders. On the suction, or intake stroke of the cylinders, air is drawn over and around the fuel jet and a charge of liquid fuel is drawn in, broken up and partially vaporised during its passage to the engine cylinders. However, I have found that in such carburettors, a relatively large amount of the atomised liquid fuel is not vaporised and enters the engine cylinder in the form of microscopic droplets. When such a charge is ignited in the engine cylinder, only that portion of the liquid fuel which has been converted into the vaporous (molecular) state, combines with the air to give an explosive mixture. The remaining portion of the liquid fuel which is drawn into the engine cylinders and remains in the form of small droplets, does not explode and impart power to the engine, but burns with a flame and raises the temperature of the engine above that at which the engine operates most efficiently, i.e. 160° to 180° F.

According to this invention, a carburettor for internal combustion engines is provided in which substantially all of the liquid fuel entering the engine cylinder will be in the vapour phase and consequently, capable of combining with the air to form a mixture which will explode and impart a maximum amount of power to the engine, and which will not burn and unduly raise the temperature of the engine.

A mixture of air and liquid fuel in truly vapour phase in the engine cylinder is obtained by vaporising all, or a large portion of the liquid fuel before it is introduced into the intake manifold of the engine. This is preferably done in a vaporising chamber, and the "dry" vaporous fuel is drawn from the top of this chamber into the intake manifold on the intake or suction stroke of the engine. The term "dry" used here refers to the fuel in the vaporous phase which is at least substantially free from droplets of the fuel in the liquid phase, which on ignition would burn rather than explode.

More particularly, the invention comprises a carburettor embodying a vaporising chamber in the bottom of which, a constant body of liquid fuel is maintained, and in the top of which there is always maintained a supply of "dry" vaporised fuel, ready for admission into the intake manifold of the engine. The supply of vaporised liquid fuel is maintained by drawing air through the supply of liquid fuel in the bottom of the vaporising chamber, and by constantly atomising a portion of the liquid fuel so that it may more readily pass into the vapour phase. This is preferably accomplished by a double-acting suction pump operated from the intake manifold, which forces a mixture of the liquid fuel and air against a plate located within the chamber. To obtain a more complete vaporisation of the liquid fuel, the vaporising chamber and the incoming air are preferably heated by the exhaust gasses from the engine. The carburettor also includes means for initially supplying a mixture of air and vaporised fuel so that starting the engine will not be dependent on the existence of a supply of fuel vapours in the vaporising chamber.

The invention will be further described in connection with the accompanying drawings, but this further disclosure and description is to be taken as an exemplification of the invention and the same is not limited thereby except as is pointed out in the claims.

Fig.1 is an elevational view of a carburettor embodying my invention.

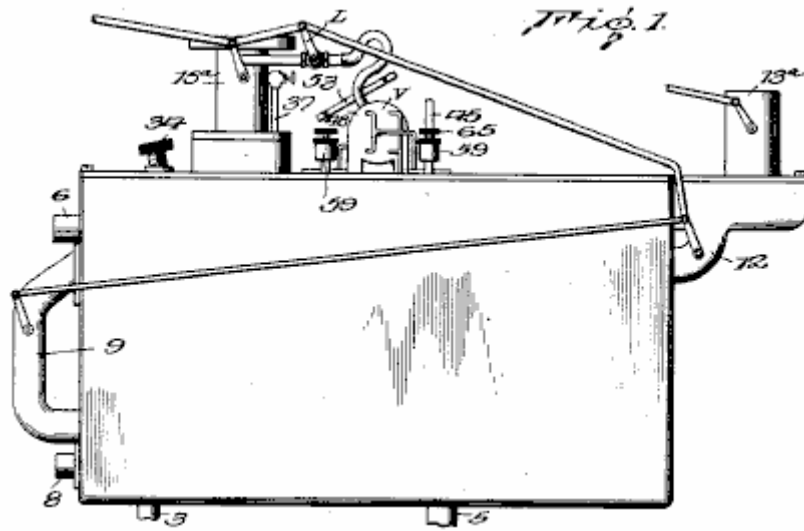

Fig.2 is a vertical cross-sectional view through the centre of Fig.1

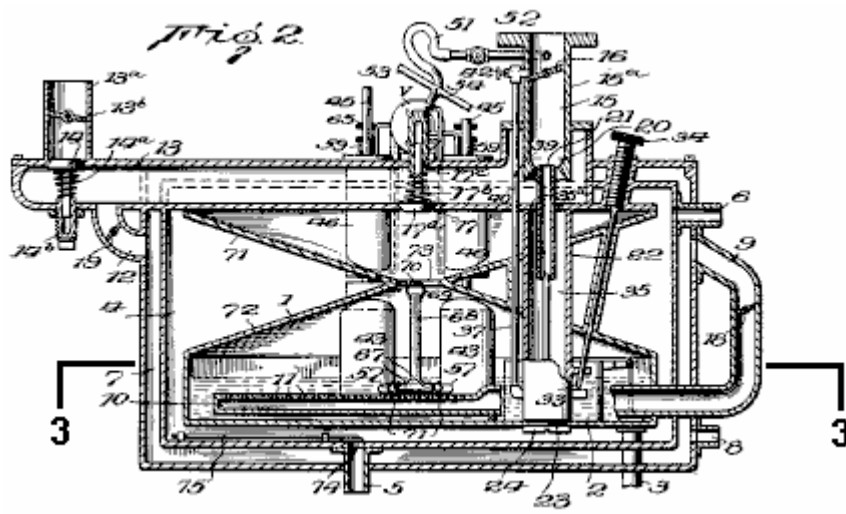

Fig.3 is a horizontal sectional view on line 3--3 of Fig.2.

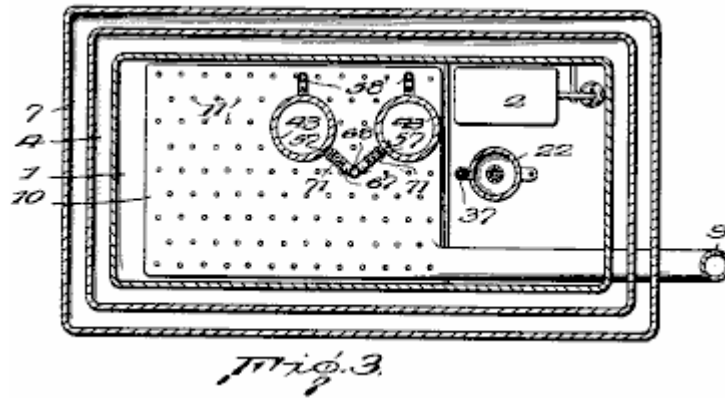

Fig.4 is an enlarged vertical sectional view through one of the pump cylinders and adjacent parts of the carburettor.

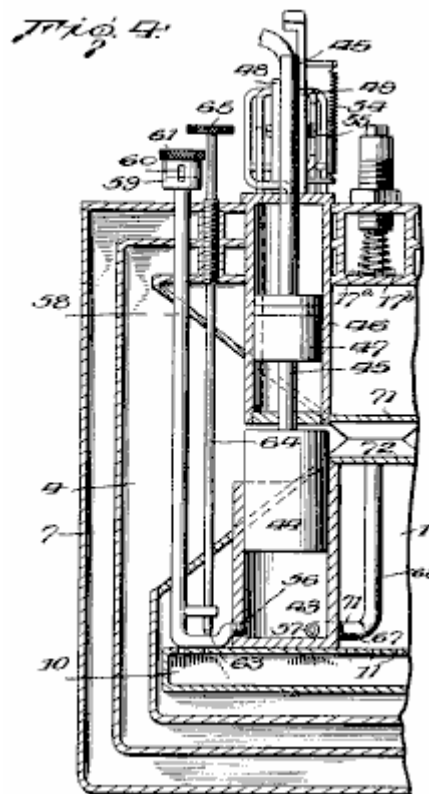

Fig.5 is an enlarged view through the complete double-acting pump and showing the associated distributing valve.

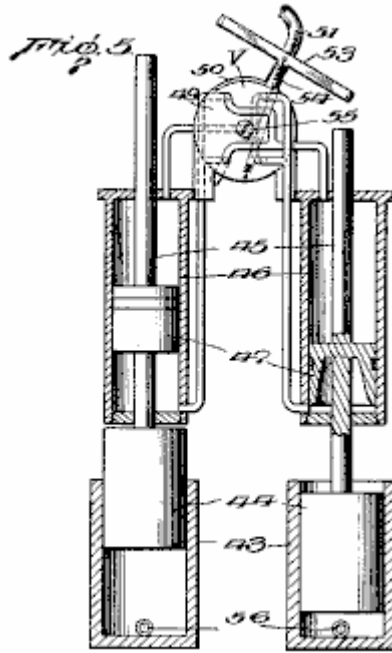

Fig.6 is an enlarged vertical sectional view through the atomising nozzle for supplying a starting charge for the engine.

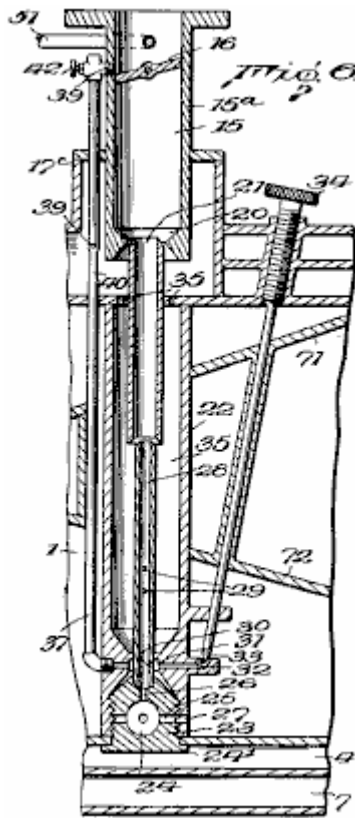

Fig.7 and Fig.8 are detail sectional views of parts 16 and 22 of Fig.6

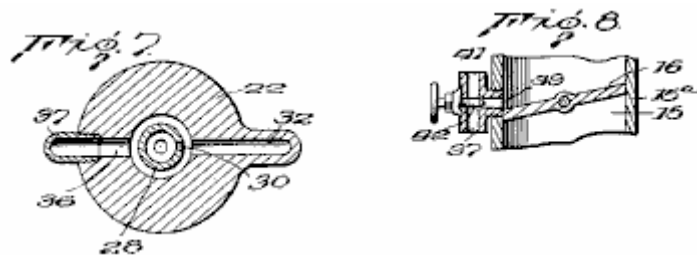
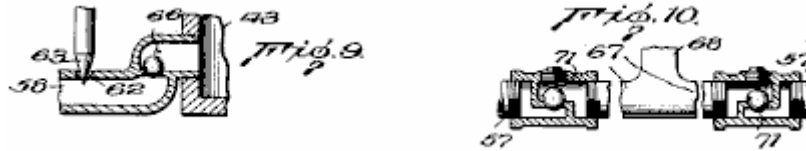

Fig.9 and Fig.10 are detail sectional views showing the inlet and outlet to the cylinders of the atomising pump.



Referring to the drawings, the numeral 1 indicates a combined vaporising chamber and fuel bowl in which liquid fuel is maintained at the level indicated in Fig.1 by a float-valve 2 controlling the flow of liquid fuel through pipe 3 which leads from the vacuum tank or other liquid fuel reservoir.

The vaporising chamber 1 is surrounded by a chamber 4 through which hot exhaust gasses from the engine, enter through pipe 5 located at the bottom of the chamber. These gasses pass around the vaporising chamber 1 and heat the chamber, which accelerates the vaporisation of the liquid fuel. The gasses then pass out through the upper outlet pipe 6.

Chamber 4 for the hot exhaust gasses, is in turn surrounded by chamber 7 into which air for vaporising part of the liquid fuel in chamber 1 enters through a lower intake pipe 8. This air passes upwards through chamber 4 through which the hot exhaust gasses pass, and so the air becomes heated. A portion of the heated air then passes through pipe 9 into an aerator 10, located in the bottom of the vaporising chamber 1 and submerged in the liquid fuel in it. The aerator 10 is comprised of a relatively flat chamber which extends over a substantial portion of the bottom of the chamber and has a large number of small orifices 11 in its upper wall. The heated air entering the aerator passes through the orifices 11 as small bubbles which then pass upwards through the liquid fuel. These bubbles, together with the heat imparted to the vaporising chamber by the hot exhaust gasses, cause a vaporisation of a portion of the liquid fuel.

Another portion of the air from chamber 7 passes through a connection 12 into passage 13, through which air is drawn directly from the atmosphere into the intake manifold. Passage 13 is provided with a valve 14 which is normally held closed by spring 14a, the tension of which may be adjusted by means of the threaded plug 14b. Passage 13 has an upward extension 13a, in which is located a choke valve 13b for assisting in starting the engine. Passage 13 passes through the vaporising chamber 1 and has its inner end communicating with passage 15 via connector 15a which is secured to the intake manifold of the engine. Passage 15 is provided with the usual butterfly valve 16 which controls the amount of fuel admitted to the engine cylinders, and consequently, regulates the speed of the engine.

The portion of passage 13 which passes through the vaporising chamber has an opening 17 normally closed by valve 17a which is held against its seat by spring 17b, the tension of which may be adjusted by a threaded plug 17c. As air is drawn past valve 14 and through passage 13 on the intake or suction stroke of the engine, valve 17a will be lifted from its seat and a portion of the dry fuel vapour from the upper portion of the vaporising chamber will be sucked into passage 13 through opening 17 and mingle with the air in it before entering passage 15.

In order to regulate the amount of air passing from chamber 7 to aerator 10 and into passage 13, pipe 9 and connection 12 are provided with suitable valves 18 and 19 respectively. Valve 18 in pipe 9 is synchronised with butterfly valve 16 in passage 15. Valve 19 is adjustable and preferably synchronised with butterfly valve 16 as shown, but this is not essential.

The bottom of passage 15 is made in the form of a venturi 20 and a nozzle 21 for atomised liquid fuel and air is located at or adjacent to the point of greatest restriction. Nozzle 21 is preferably supplied with fuel from the supply of liquid fuel in the bottom of the vaporising chamber, and to that end, a member 22 is secured within the vaporising chamber by a removable threaded plug 23 having a flanged lower end 24. Plug 22 extends through an opening in the bottom of chamber 1, and is threaded into the bottom of member 22. This causes the bottom wall of chamber 1 to be securely clamped between the lower end of member 22 and flange 24, thus securely retaining member 22 in place.

Plug 23 is provided with a sediment bowl 24 and extending from bowl 24 are several small passages 25 extending laterally, and a central vertical passage 26. The lateral passages 25 register with corresponding passages 27 located in the lower end of member 22 at a level lower than that at which fuel stands in chamber 1, whereby liquid fuel is free to pass into bowl 24.

Vertical passage 26 communicates with a vertical nozzle 28 which terminates within the flaring lower end of nozzle 21. The external diameter of nozzle 26 is less than the interior diameter of the nozzle 21 so that a space is provided between them for the passage of air or and vapour mixtures. Nozzle 26 is also provided with a series of

inlets **29**, for air or air and vapour mixtures, and a fuel inlet **30**. Fuel inlet **30** communicates with a chamber **31** located in the member **22** and surrounding the nozzle **28**. Chamber **30** is supplied with liquid fuel by means of a passage **32** which is controlled by a needle valve **33**, the stem of which, extends to the outside of the carburettor and is provided with a knurled nut **34** for adjusting purposes.

The upper end of member **22** is made hollow to provide a space **35** surrounding the nozzles **21** and **28**. The lower wall of the passage **13** is provided with a series of openings **35a**, to allow vapours to enter space **35** through them. The vapours may then pass through inlets **29** into the nozzle **28**, and around the upper end of the nozzle **28** into the lower end of nozzle **21**.

Extending from chamber **31** at the side opposite passage **32**, is a passage **36** which communicates with a conduit **37** which extends upwards through passage **13**, and connects through a lateral extension **39**, with passage **15** just above the butterfly valve **16**. The portion of conduit **37** which extends through passage **13** is provided with an orifice **39** through which air or air and fuel vapour may be drawn into the conduit **37** mingle with and atomise the liquid fuel being drawn through the conduit. To further assist in this atomisation of the liquid fuel passing through conduit **37**, the conduit is restricted at **40** just below orifice **39**.

The upper end of conduit **37** is in communication with the atmosphere through opening **41** through which air may be drawn directly into the upper portion of the conduit. The proportion of air to combustible vapours coming through conduit **37** is controlled by needle valve **42**.

As nozzle **21** enters directly into the lower end of passage **15**, suction in the inlet manifold will, in turn, create a suction on nozzle **21** which will cause a mixture of atomised fuel and air to be drawn directly into the intake manifold. This is found to be desirable when starting the engine, particularly in cold weather, when there might not be an adequate supply of vapour in the vaporising chamber, or the mixture of air and vapour passing through passage **13** might be to "lean" to cause a prompt starting of the engine. At such times, closing the choke valve **13b** will cause the maximum suction to be exerted on nozzle **21** and the maximum amount of air and atomised fuel to be drawn directly into the intake manifold. After the engine has been started, only a small portion of the combustible air and vapour mixture necessary for proper operation of the engine is drawn through nozzle **21** as the choke valve will then be open to a greater extent and substantially all of the air and vapour mixture necessary for operation of the engine will be drawn through the lower end **20** of passage **15**, around nozzle **21**.

Conduit **37** extending from fuel chamber **31** to a point above butterfly valve **16** provides an adequate supply of fuel when the engine is idling with valve **16** closed or nearly closed.

The casings forming chambers **1**, **4** and **7**, will be provided with the necessary openings, to subsequently be closed, so that the various parts may be assembled, and subsequently adjusted or repaired.

The intake stroke of the engine creates a suction in the intake manifold, which in turn causes air to be drawn past spring valve **14** into passage **13** and simultaneously a portion of the dry fuel vapour from the top of vaporising chamber **1** is drawn through opening **17** past valve **17a** to mix with the air moving through the passage. This mixture then passes through passage **15** to the intake manifold and engine cylinders.

The drawing of the dry fuel vapour into passage **13** creates a partial vacuum in chamber **1** which causes air to be drawn into chamber **7** around heated chamber **4** from where it passes through connection **12** and valve **19**, into passage **13** and through pipe **9** and valve **18** into aerator **10**, from which it bubbles up through the liquid fuel in the bottom of chamber **1** to vaporise more liquid fuel.

To assist in maintaining a supply of dry fuel vapour in the upper portion of vaporising chamber **1**, the carburettor is provided with means for atomising a portion of the liquid fuel in vaporising chamber **1**. This atomising means preferably is comprised of a double-acting pump which is operated by the suction existing in the intake manifold of the engine.

The double-acting pump is comprised of a pair of cylinders **43** which have their lower ends located in the vaporising chamber **1**, and each of which has a reciprocating pump piston **44** mounted in it. Pistons **44** have rods **45** extending from their upper ends, passing through cylinders **46** and have pistons **47** mounted on them within the cylinders **46**.

Cylinders **46** are connected at each end to a distributing valve **V** which connects the cylinders alternately to the intake manifold so that the suction in the manifold will cause the two pistons **44** to operate as a double-acting suction pump.

The distributing valve **V** is comprised of a pair of discs **48** and **49** between which is located a hollow oscillatable chamber **50** which is constantly subjected to the suction existing in the intake manifold through connection **51**

having a valve **52** in it. Chamber **50** has a pair of upper openings and a pair of lower openings. These openings are so arranged with respect to the conduits leading to the opposite ends of cylinders **46** that the suction of the engine simultaneously forces one piston **47** upwards while forcing the other one downwards.

The oscillatable chamber **50** has a T-shaped extension **53**. The arms of this extension are engaged alternately by the upper ends of the piston rods **45**, so as to cause valve **V** to connect cylinders **46** in sequence to the intake manifold.

Spring **54** causes a quick opening and closing of the ports leading to the cylinders **46** so that at no time will the suction of the engine be exerted on both of the pistons **47**. The tension between discs **48** and **49** and the oscillatable chamber **50** may be regulated by screw **55**.

The particular form of the distributing valve **V** is not claimed here so a further description of operation is not necessary. As far as the present invention is concerned, any form of means for imparting movement to pistons **47** may be substituted for the valve **V** and its associated parts.

The cylinders **43** are each provided with inlets and outlets **56** and **57**, each located below the fuel level in chamber **1**. The inlets **56** are connected to horizontally and upwardly extending conduits **58** which pass through the carburettor to the outside. The upper ends of these conduits are enlarged at **59** and are provided with a vertically extending slot **60**. The enlarged ends **59** are threaded on the inside to accept plugs **61**. The position of these plugs with respect to slots **60** determines the amount of air which may pass through the slots **60** and into cylinder **43** on the suction stroke of the pistons **44**.

The upper walls of the horizontal portions of conduits **58** have an opening **62** for the passage of liquid fuel from chamber **1**. The extent to which liquid fuel may pass through these openings is controlled by needle valves **63**, whose stems **64** pass up through and out of the carburettor and terminate in knurled adjusting nuts **65**.

The horizontal portion of each conduit **58** is also provided with a check valve **66** (shown in **Fig.10**) which allows air to be drawn into the cylinders through conduits **58** but prevents liquid fuel from being forced upwards through the conduits on the down stroke of pistons **44**.

Outlets **57** connect with horizontal pipes **67** which merge into a single open-ended pipe **68** which extends upwards. The upper open end of this pipe terminates about half way up the height of the vaporising chamber **1** and is provided with a bail **69** which carries a deflecting plate **70** positioned directly over the open end of pipe **68**.

The horizontal pipes **67** are provided with check valves **71** which permit the mingled air and fuel to be forced from cylinders **43** by the pistons **44**, but which prevent fuel vapour from being drawn from chamber **1** into cylinders **43**.

When operating, pistons **44** on the 'up' strokes, draw a charge of air and liquid fuel into cylinders **43**, and on the 'down' stroke, discharge the charge in an atomised condition through pipes **67** and **68**, against deflecting plate **70** which further atomises the particles of liquid fuel so that they will readily vaporise. Any portions of the liquid fuel which do not vaporise, drop down into the supply of liquid fuel in the bottom of the vaporising chamber where they are subjected to the vaporising influence of the bubbles of heated air coming from the aerator **10**, and may again pass into the cylinders **43**.

As previously stated, the vaporised fuel for introduction into the intake manifold of the engine, is taken from the upper portion of the vaporising chamber **1**. To ensure that the vapour in this portion of the chamber shall contain no, or substantially no, entrained droplets of liquid fuel, chamber **1** is divided into upper and lower portions by the walls **71** and **72** which converge from all directions to form a central opening **73**. With the vaporising chamber thus divided into upper and lower portions which are connected only by the relatively small opening **73**, any droplets entrained by the bubbles rising from the aerator **10**, will come into contact with the sloping wall **72** and be deflected back into the main body of liquid fuel in the bottom of the chamber. Likewise, the droplets of atomised fuel being forced from the upper end of pipe **68** will, on striking plate **70**, be deflected back into the body of liquid fuel and not pass into the upper portion of the chamber.

In order that the speed of operation of the atomising pump may be governed by the speed at which the engine is running, and further, that the amount of air admitted from chamber **7** to the aerator **10**, and to passage **13** through connection **12**, may be increased as the speed of the engine increases, the valves **18**, **19** and **52** and butterfly valve **16** are all connected by a suitable linkage **L** so that as butterfly valve **16** is opened to increase the speed of the engine, valves **18**, **19** and **52** will also be opened.

As shown in **Fig.2**, the passage of the exhaust gasses from the engine to the heating chamber **4**, located between the vaporising chamber and the air chamber **7**, is controlled by valve **74**. The opening and closing of valve **74** is controlled by a thermostat in accordance with the temperature inside chamber **4**, by means of an adjustable metal

rod 75 having a high coefficient of expansion, whereby the optimum temperature may be maintained in the vaporising chamber, irrespective of the surrounding temperature.

From the foregoing description, it will be understood that the present invention provides a carburettor for supplying to internal combustion engines, a comingled mixture of air and liquid fuel vapour free from microscopic droplets of liquid fuel which would burn rather than explode in the cylinders and that a supply of such dry vaporised fuel is constantly maintained in the carburettor.

The Second High MPG Carburettor of Charles Pogue

US Patent 1,997,497

9th April 1935

Inventor: Charles N. Pogue

CARBURETTOR

This patent describes a carburettor design which was able to produce very high mpg figures using the gasoline available in the USA in the 1930s but which is no longer available as the oil industry does not want functional high mpg carburettors to be available to the public.

DESCRIPTION

This invention relates to a device for obtaining an intimate contact between a liquid in a truly vaporous state and a gas, and particularly to such a device which may serve as a carburettor for internal combustion engines and is an improvement on the form of device shown in my Patent No. 1,938,497, granted on 5th December 1933.

In carburettors commonly used for supplying a combustible mixture of air and liquid fuel to internal combustion engines, a relatively large amount of the atomised liquid fuel is not vaporised and enters the engine cylinder more or less in the form of microscopic droplets. When such a charge is ignited in the engine cylinder, only that portion of the liquid fuel which has been converted into the vaporous, and consequently molecular state, combines with the air to give an explosive mixture. The remaining portion of the liquid fuel which is drawn into the engine cylinders remains in the form of small droplets and does not explode imparting power to the engine, but instead burns with a flame and raises the engine temperature above that at which the engine operates most efficiently, i.e. from 160° F. to 180° F.

In my earlier patent, there is shown and described a form of carburettor in which the liquid fuel is substantially completely vaporised prior to its introduction into the engine cylinders, and in which, means are provided for maintaining a reserve supply of "dry" vapour available for introduction into the engine cylinder. Such a carburettor has been found superior to the standard type of carburettor referred to above, and to give a better engine performance with far less consumption of fuel.

It is an object of the present invention to provide a carburettor in which the liquid fuel is broken up and prepared in advance of and independent of the suction of the engine and in which a reserve supply of dry vapour will be maintained under pressure, ready for introduction into the engine cylinder at all times. It is also an object of the invention to provide a carburettor in which the dry vapour is heated to a sufficient extent prior to being mixed with the main supply of air which carries it into the engine cylinder, to cause it to expand so that it will be relatively lighter and will become more intimately mixed with the air, prior to explosion in the engine cylinders.

I have found that when the reserve supply of dry vapour is heated and expanded prior to being mixed with the air, a greater proportion of the potential energy of the fuel is obtained and the mixture of air and fuel vapour will explode in the engine cylinders without any apparent burning of the fuel which would result in unduly raising the operating temperature of the engine.

More particularly, the present invention comprises a carburettor in which liquid fuel vapour is passed from a main vaporising chamber under at least a slight pressure, into and through a heated chamber where it is caused to expand and in which droplets of liquid fuel are either vaporised or separated from the vapour, so that the fuel finally introduced into the engine cylinders is in the true vapour phase. The chamber in which the liquid fuel vapour is heated and caused to expand, is preferably comprised of a series of passages through which the vapour and exhaust gases from the engine pass in tortuous paths in such a manner that the exhaust gasses are brought into heat interchange relation with the vapour and give up a part of their heat to the vapour, thus causing heating and expansion of the vapour.

The invention will be further described in connection with the accompanying drawings, but this further disclosure and description is to be taken merely as an exemplification of the invention and the invention is not limited to the embodiment so described.

DESCRIPTION OF THE DRAWINGS

Fig.1 is a vertical cross-sectional view through a carburettor embodying my invention.

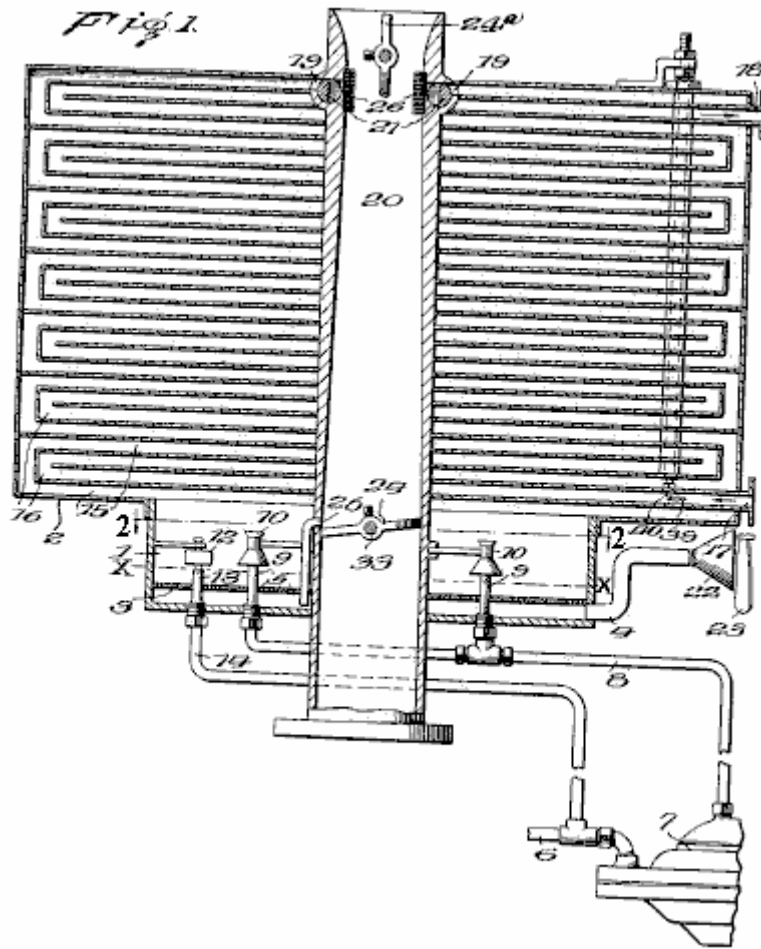

Fig. 2 is a horizontal sectional view through the main vaporising or atomising chamber, taken on line 2--2 of Fig. 1

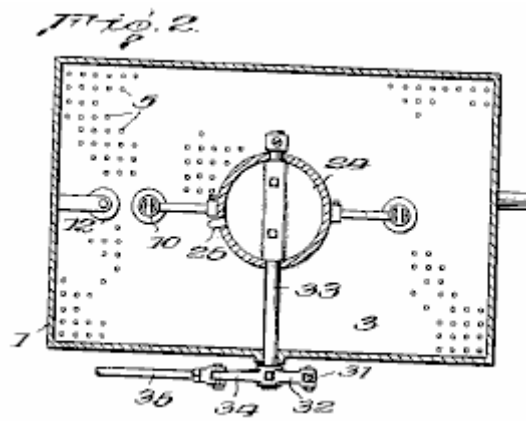

Fig. 3 is a side elevation of the carburettor.

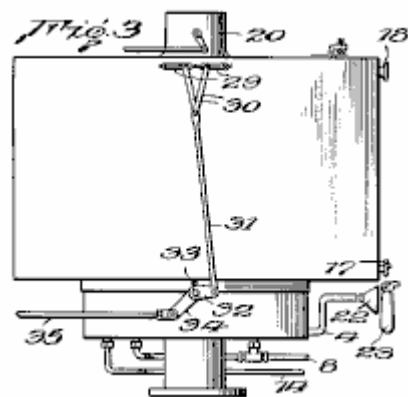

Fig.4 is a detail sectional view of one of the atomising nozzles and its associated parts

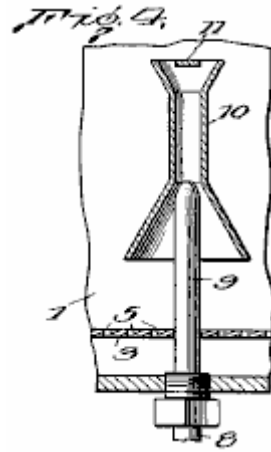

Fig.5 is a detail cross-sectional view showing the means for controlling the passage of gasses from the vapour expanding chamber into the intake manifold of the engine.

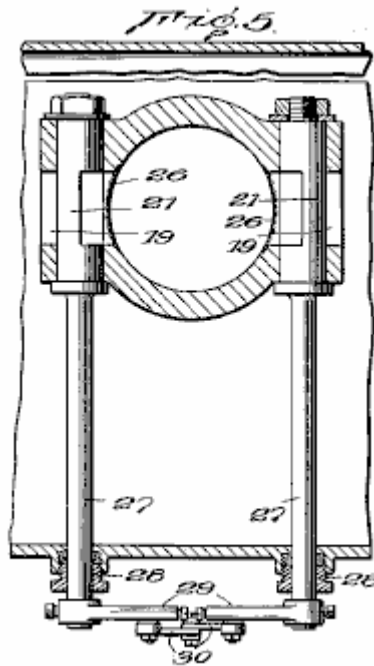

Fig.6 is a perspective view of one of the valves shown in Fig.5

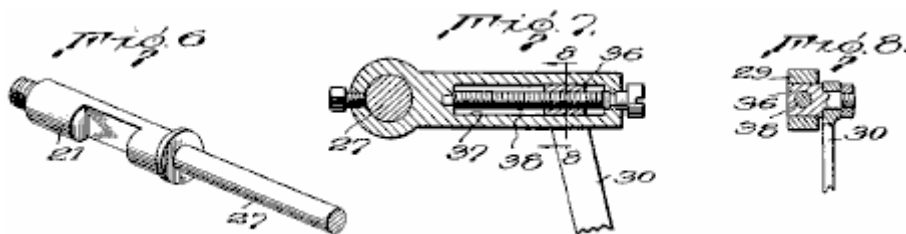

Fig.7 is a cross-sectional view showing means for adjusting the valves shown in Fig.5

Fig.8 is a cross-sectional view on line 8--8 of Fig.7

Referring now to the drawings, the numeral 1 indicates a main vaporising and atomising chamber for the liquid fuel located at the bottom of, and communicating with, a vapour heating and expanding chamber 2.

The vaporising chamber is provided with a perforated false bottom **3** and is normally filled with liquid fuel to the level **x**. Air enters the space below the false bottom **3** via conduit **4** and passes upwards through perforations **5** in the false bottom and then bubbles up through the liquid fuel, vaporising a portion of it.

To maintain the fuel level **x** in chamber **1**, liquid fuel passes from the usual fuel tank (not shown) through pipe **8** into and through a pair of nozzles **9** which have their outlets located in chamber **1**, just above the level of the liquid fuel in it. The pump **7** may be of any approved form but is preferably of the diaphragm type, as such fuel pumps are now standard equipment on most cars.

The nozzles **9** are externally threaded at their lower ends to facilitate their assembly in chamber **1** and to permit them to be removed readily, should cleaning be necessary.

The upper ends of nozzles **9** are surrounded by venturi tubes **10**, having a baffle **11**, located at their upper ends opposite the outlets of the nozzles. The liquid fuel being forced from the ends of nozzles **9** into the restricted portions of the Venturi tubes, causes a rapid circulation of the air and vapour in the chamber through the tubes **10** and brings the air and vapour into intimate contact with the liquid fuel, with the result that a portion of the liquid fuel is vaporised. The part of the liquid fuel which is not vaporised, strikes the baffles **11** and is further broken up and deflected downwards into the upward-flowing current of air and vapour.

Pump **7** is regulated to supply a greater amount of liquid fuel to the nozzles **9** than will be vaporised. The excess drops into chamber **1** and causes the liquid to be maintained at the indicated level. When the liquid fuel rises above that level, a float valve **12** is lifted, allowing the excess fuel to flow out through overflow pipe **13** into pipe **14** which leads back to pipe **6** on the intake side of pump **7**. Such an arrangement allows a large amount of liquid fuel to be circulated by pump **7** without more fuel being withdrawn from the fuel tank than is actually vaporised and consumed in the engine. As the float valve **12** will set upon the end of the outlet pipe **13** as soon as the liquid level drops below the indicated level, there is no danger of vapour passing into pipe **14** and from there into pump **7** and interfere with its normal operation.

The upper end of the vaporising and atomising chamber **1** is open and vapour formed by air bubbling through the liquid fuel in the bottom of the chamber and that formed as the result of atomisation at nozzles **9**, pass into the heating and expanding chamber **2**. As is clearly shown in **Fig.1**, chamber **2** comprises a series of tortuous passages **15** and **16** leading from the bottom to the top. The fuel vapour passes through passages **15** and the exhaust gasses of the engine pass through passages **16**, a suitable entrance **17** and exit **18** being provided for that purpose.

The vapour passing upwards in a zigzag path through passages **15**, will be brought into heat interchange relation with the hot walls of the passages **16** traversed by the hot exhaust gasses. The total length of the passages **15** and **16** is such that a relatively large reserve supply of the liquid fuel is always maintained in chamber **2**, and by maintaining the vapour in heat interchange relation with the hot exhaust gasses for a substantial period, the vapour will absorb sufficient heat to cause it to expand, with the result that when it is withdrawn from the top of chamber **2**, it will be in the true vapour phase, and due to expansion, relatively light.

Any minute droplets of liquid fuel entrained by the vapour in chamber **1** will precipitate out in the lower passages **15** and flow back into chamber **1**, or else be vaporised by the heat absorbed from the exhaust gasses during its passage through chamber **2**.

The upper end of vapour passage **15** communicates with openings **19** adjacent to the upper end of a down-draft air tube **20** leading to the intake manifold of the engine. Valves **21** are interposed in openings **19**, so that the passage of the vapour through them into the air tube may be controlled. Valves **21** are preferably of the rotary plug type and are controlled as described below.

Suitable means are provided for causing the vapour to be maintained in chamber **2**, under a pressure greater than atmospheric, so that when the valves **21** are opened, the vapour will be forced into air tube **20** independent of the engine suction. Such means may comprise an air pump (not shown) for forcing air through pipe **4** into chamber **1** beneath the false bottom **3**, but I prefer merely to provide pipe **4** with a funnel-shaped inlet end **22** and placement just behind the usual engine fan **23**. This causes air to pass through pipe **4** with sufficient force to maintain the desired pressure in chamber **2**, and the air being drawn through the radiator by the fan will be preheated prior to its introduction into chamber **1** and hence will vaporise greater amounts of the liquid fuel. If desired, pipe **4** may be surrounded by an electric or other heater, or exhaust gasses from the engine may be passed around it to further preheat the air passing through it prior to its introduction into the liquid fuel in the bottom of chamber **1**.

Air tube **20** is provided with a butterfly throttle valve **24** and a choke valve **24a**, as is customary with carburetors used for internal combustion engines. The upper end of air tube **20** extends above chamber **2** a distance sufficient to receive an air filter and/or silencer, if desired.

A low-speed or idling jet **25** has its upper end communicating with the passage through air tube **20** adjacent to the throttling valve **24** and its lower end extending into the liquid fuel in the bottom of chamber **1**, for supplying fuel to the engine when the valves are in a position such as to close the passages **19**. However, the passage through idling jet **25** is so small that under normal operations, the suction on it is not sufficient to lift fuel from the bottom of chamber **1**.

To prevent the engine from backfiring into vapour chamber **2**, the ends of the passages **19** are covered with a fine mesh screen **26** which, operating on the principle of the miner's lamp, will prevent the vapour in chamber **2** from exploding in case of a backfire, but which will not interfere substantially with the passage of the vapour from chamber **2** into air tube **20** when valves **21** are open. Air tube **20** is preferably in the form of a venturi with the greatest restriction being at that point where the openings **19** are located, so that when valves **21** are opened, there will be a pulling force on the vapour caused by the increased velocity of the air at the restricted portion of air tube **20** opposite the openings **19**, as well as an expelling force on them due to the pressure in chamber **2**.

As shown in **Fig.3**, the operating mechanism of valves **21** is connected to the operating mechanism for throttle valve **24**, so that they are opened and closed simultaneously with the opening and closing of the throttle valve, ensuring that the amount of vapour supplied to the engine will, at all times, be in proportion to the demands placed upon the engine. To that end, each valve **21** has an extension, or operating stem **27**, protruding through one of the side walls of the vapour-heating and expanding chamber **2**. Packing glands **28** of ordinary construction, surround stems **27** where they pass through the chamber wall, to prevent leakage of vapour at those points.

Operating arms **29** are rigidly secured to the outer ends of stems **27** and extend towards each other. The arms are pivotally and adjustably connected to a pair of links **30** which, at their lower ends are pivotally connected to an operating link **31**, which in turn, is pivotally connected to arm **32** which is rigidly secured on an outer extension **33** of the stem of the throttle valve **24**. Extension **33** also has rigidly connected to it, arm **34** to which is connected operating link **35** leading from the means for accelerating the engine.

The means for adjusting the connection from the upper ends of links **30** to valve stems **27** of valves **21**, so that the amount of vapour delivered from chamber **2** may be regulated to cause the most efficient operation of the particular engine to which the carburettor is attached, comprises angular slides **36**, to which the upper ends of links **30** are fastened, and which cannot rotate but can slide in guideways **37** located in arms **29**. Slides **36** have threaded holes through which screws **38** pass. Screws **38** are rotatably mounted in arms **29**, but are held against longitudinal movement so that when they are rotated, slides **36** will be caused to move along the guideways **37** and change the relative position of links **30** to the valve stems **27**, so that a greater or less movement, and consequently, a greater or less opening of the ports **19** will take place when throttle valve **24** is operated.

For safety, and for most efficient operation of the engine, the vapour in chamber **2** should not be heated or expanded beyond a predetermined amount, and in order to control the extent to which the vapour is heated, and consequently, the extent to which it expands, a valve **39** is located in the exhaust passage **16** adjacent to inlet **17**. Valve **39** is preferably thermostatically controlled, as for example, by an expanding rod thermostat **40**, which extends through chamber **2**. However, any other means may be provided for reducing the amount of hot exhaust gasses entering passage **16** when the temperature of the vapour in the chamber reaches or exceeds the optimum.

The carburettor has been described in detail in connection with a down-draft type of carburettor, but it is to be understood that its usefulness is not to be restricted to that particular type of carburettor, and that the manner in which the mixture of air and vapour is introduced into the engine cylinders is immaterial as far as the advantages of the carburettor are concerned.

The term "dry vapour" is used to define the physical condition of the liquid fuel vapour after removal of liquid droplets or the mist which is frequently entrained in what is ordinarily termed a vapour.

From the foregoing description it will be seen that the present invention provides a carburettor in which the breaking up of the liquid fuel for subsequent use is independent of the suction created by the engine, and that after the liquid fuel is broken up, it is maintained under pressure in a heated space for a length of time sufficient to permit all entrained liquid particles to be separated or vaporised and to permit the dry vapour to expand prior to its introduction into and admixture with the main volume of air passing into the engine cylinders.

The Third High MPG Carburettor of Charles Pogue

US Patent 2,026,798

7th January 1936

Inventor: Charles N. Pogue

CARBURETTOR

This patent describes a carburettor design which was able to produce very high mpg figures using the gasoline available in the USA in the 1930s but which is no longer available as the oil industry does not want functional high mpg carburettors to be available to the public.

DESCRIPTION

This invention relates to carburettors suitable for use with internal combustion engines and is an improvement on the carburettors shown in my Patents Nos. 1,938,497, granted on 5th December 1933 and 1,997,497 granted on 9th April 1935.

In my earlier patents, an intimate contact between such as the fuel used for internal combustion engines, and a gas such as air, is obtained by causing the gas to bubble up through a body of the liquid. The vaporised liquid passes into a vapour chamber which preferably is heated, and any liquid droplets are returned to the body of the liquid, with the result that the fuel introduced into the combustion chambers is free of liquid particles, and in the molecular state so that an intimate mixture with the air is obtained to give an explosive mixture from which nearer the maximum energy contained in the liquid fuel is obtained. Moreover, as there are no liquid particles introduced into the combustion chambers, there will be no burning of the fuel and consequently, the temperature of the engine will not be increased above that at which it operates most efficiently.

In my Patent No. 1,997,497, the air which is to bubble up through the body of the liquid fuel is forced into and through the fuel under pressure and the fuel vapour and air pass into a chamber where they are heated and caused to expand. The introduction of the air under pressure and the expansion of the vaporous mixture ensures a sufficient pressure being maintained in the vapour heating and expanding chamber, to cause at least a portion of it to be expelled from it into the intake manifold as soon as the valve controlling the passage to it is opened.

In accordance with the present invention, improved means are provided for maintaining the vaporous mixture in the vapour-heating chamber under a predetermined pressure, and for regulating such pressure so that it will be at the optimum for the particular conditions under which the engine is to operate. Such means preferably comprises a reciprocating pump operated by a vacuum-actuated motor for forcing the vapour into and through the chamber. The pump is provided with a suitable pressure-regulating valve so that when the pressure in the vapour-heating chamber exceeds the predetermined amount, a portion of the vapour mixture will be by-passed from the outlet side to the inlet side of the pump, and so be recirculated.

The invention will be described further in connection with the accompanying drawings, but such further disclosure and description is to be taken merely as an exemplification of the invention, and the invention is not limited to that embodiment of the invention.

DESCRIPTION OF THE DRAWINGS

Fig.1 is a side elevation of a carburettor embodying the invention.

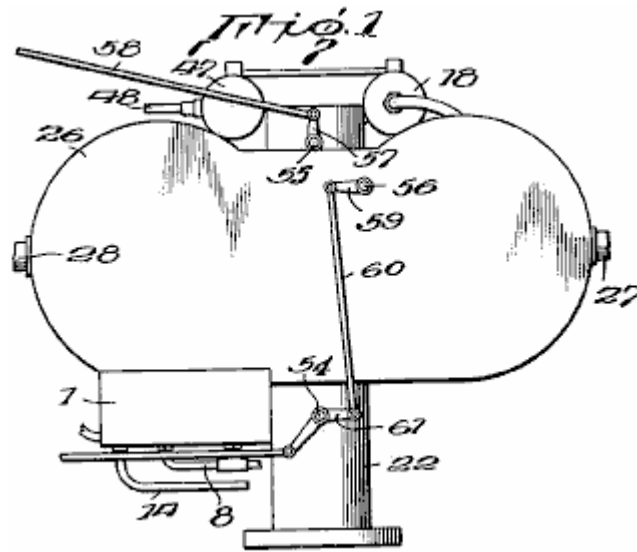

Fig.2 is a plan view of the carburettor

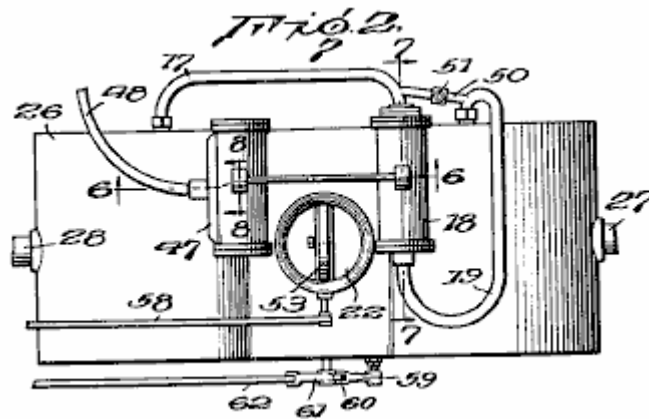

Fig.3 is an enlarged vertical section view.

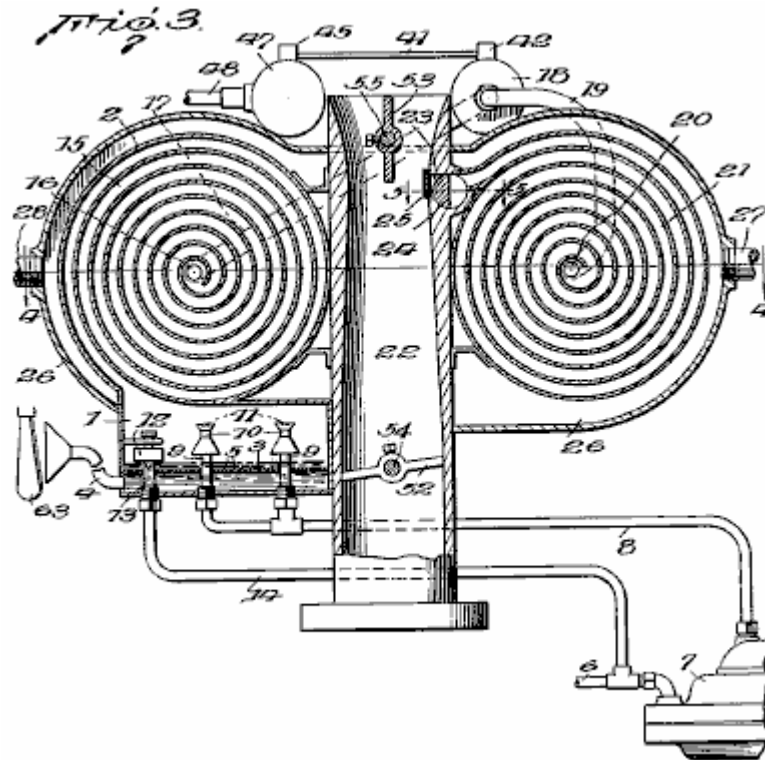

Fig.4 is a transverse sectional view on line 4--4 of Fig.3

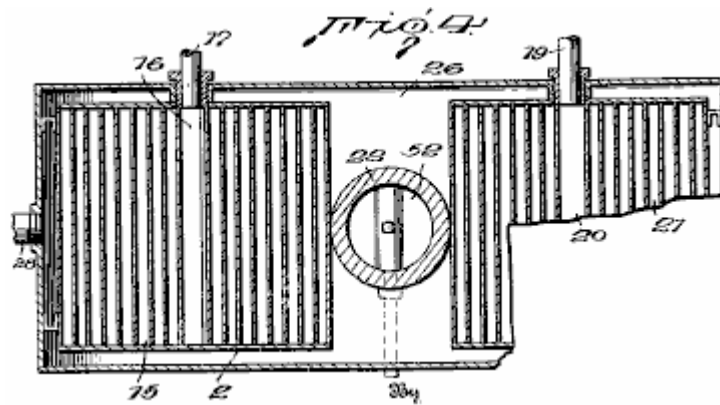

Fig.5 is a detail sectional view on line 5--5 of Fig.3

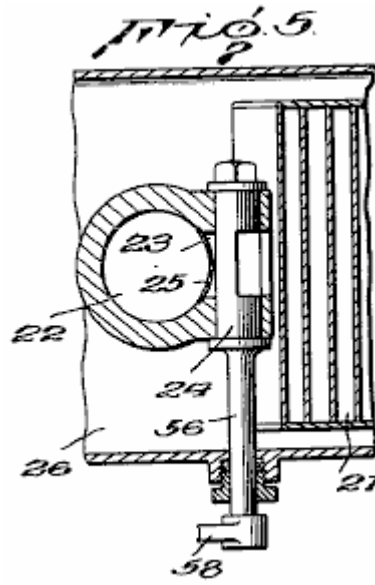

Fig.6 is a transverse sectional view through the pump and actuating motor, taken on line 6--6 of Fig.2

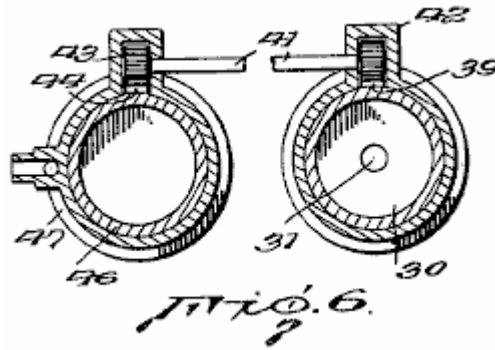

Fig.7 is a longitudinal sectional view through the pump taken on line 7--7 of Fig.2

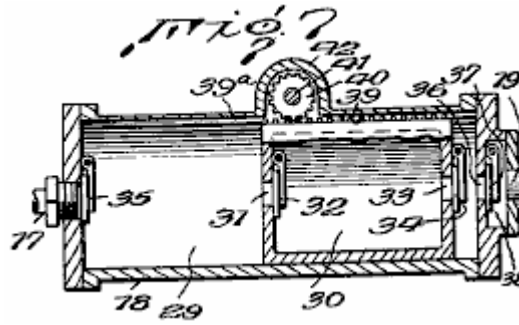
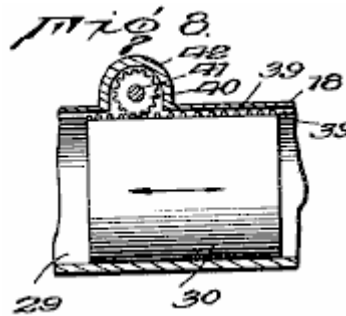

Fig.8 is a longitudinal sectional view through a part of the pump cylinder, showing the piston in elevation.



In the drawings, a vaporising and atomising chamber **1** is located at the bottom of the carburettor and has an outlet at its top for the passage of fuel vapour and air into a primary vapour-heating chamber **2**.

The vaporising chamber **1** is provided with a perforated false bottom **3** and is normally filled with liquid fuel to the level indicated in **Fig.1**. Air is introduced via conduit **4** into the space below the false bottom **3**, and then through the perforations **5** in the false bottom which breaks it into a myriad of fine bubbles, which pass upwards through the liquid fuel above the false bottom.

Liquid fuel for maintaining the level indicated in chamber **1** passes from the usual fuel tank (not shown) through pipe **6**, and is forced by pump **7** through pipe **8** through a pair of nozzles **9** having their outlets located in chamber **1**, just above the level of the liquid fuel in it. Pump **7** may be of any approved form but is preferably of the diaphragm type, as such fuel pumps are now standard equipment on most cars.

The nozzles **9** are externally threaded at their lower ends to facilitate their assembly in chamber **1** and to permit them to be readily removed should cleaning become necessary.

The upper ends of nozzles **9** are surrounded by venturi tubes **10** having baffles **11** located at their upper ends opposite the outlets of the nozzles, as is shown and described in detail in my Patent No. 1,997,497. The liquid fuel being forced from the ends of nozzles **9** into the restricted portions of the venturi tubes, causes a rapid circulation of the air and vapour in the chamber through tubes **10** and brings the air and vapour into intimate contact with the liquid fuel, with the result that a portion of the liquid fuel is vaporised. Unvaporised portions of the liquid fuel strike the baffles **11** and are thereby further broken up and deflected downwards into the upward-flowing current of air and vapour.

Pump **7** is regulated to supply a greater amount of liquid fuel to nozzles **9** than will be vaporised. The excess liquid fuel drops into chamber **1** which causes the liquid there to be maintained at the indicated level. When the liquid fuel rises above that level, float valve **12** opens and the excess fuel flows through overflow pipe **13** into pipe **14** which leads back to pipe **6** on the intake side of pump **7**. Such an arrangement permits a large amount of liquid fuel to be circulated by pump **7** without more fuel being withdrawn from the fuel tank than is actually vaporised and consumed by the engine. As float valve **12** will set upon the end of the outlet pipe **13** as soon as the liquid level drops below the indicated level, there is no danger of vapour passing into pipe **14** and thence into pump **7** to interfere with its normal operation.

The amount of liquid fuel vaporised by nozzles **9** and by the passage of air through the body of liquid, is sufficient to provide a suitably enriched vaporous mixture for introducing into the passage leading to the intake manifold of the engine, through which the main volume of air passes.

Vapour formed by air bubbling through the liquid fuel in the bottom of chamber **1** and that formed by the atomisation at the nozzles **9**, pass from the top of that chamber into the primary heating chamber **2**. As is clearly shown in **Fig.1**, chamber **2** comprises a relatively long spiral passage **15** through which the vaporous mixture gradually passes inwards to a central outlet **16** to which is connected a conduit **17** leading to a reciprocating pump **18** which forces the vaporous mixture under pressure into conduit **19** leading to a central inlet **20** of a secondary heating chamber **21**, which like the primary heating chamber, comprises a relatively long spiral. The vaporous mixture gradually passes outwards through the spiral chamber **21** and enters a downdraft air tube **22**, leading to the intake manifold of the engine, through an outlet **23** controlled by a rotary plug valve **24**.

To prevent the engine from backfiring into vapour chamber **2**, the ends of passage **19** are covered with a fine mesh screen **25**, which, operating on the principle of a miner's lamp, will prevent the vapour in chamber **2** from exploding in case of a backfire, but will not interfere substantially with the passage of the vapour from chamber **21** into air tube **22** when valve **24** is open.

The air tube **22** is preferably in the form of a venturi with the greatest constriction being at that point where outlet **23** is located, so that when valve **24** is opened, there will be a pulling force on the vaporous mixture due to the increased velocity of the air at the restricted portion of the air tube opposite outlet **23**, as well as an expelling force on it due to the pressure maintained in chamber **21** by pump **18**.

Both the primary and secondary spiral heating chambers **15** and **21**, and the central portion of air tube **22** are enclosed by a casing **26** having an inlet **27** and an outlet **28** for a suitable heating medium such as the gasses coming from the exhaust manifold.

Pump **18**, used to force the vaporous mixture from primary heating chamber **2** into and through the secondary chamber **21**, includes a working chamber **29** for hollow piston **30**, provided with an inlet **31** controlled by valve **32**, and an outlet **33** controlled by a valve **34**. The end of the working chamber **29** to which is connected conduit **17**, which conducts the vaporous mixture from primary heating chamber **2**, has an inlet valve **35**, and the opposite end of the working chamber has an outlet **36** controlled by valve **37** positioned in an auxiliary chamber **38**, to which is connected outlet pipe **19** which conducts the vaporous mixture under pressure to the secondary heating chamber **21**. Each of the valves **32**, **34**, **35** and **37** is of the one-way type. They are shown as being gravity-actuated flap valves, but it will be understood that spring-loaded or other types of one-way valves may be used if desired.

One side of piston **30** is formed with a gear rack **39** which is received in a groove **39a** of the wall forming the cylinder of the pump. The gear rack **39** engages with an actuating spur gear **40** carried on one end of shaft **41** and operating in a housing **42** formed on the pump cylinder. The other end of shaft **41** carries a spur gear **43**, which engages and is operated by a gear rack **44** carried on a piston **46** of a double-acting motor **47**. The particular construction of the double-acting motor **47** is not material, and it may be of a vacuum type commonly used for operating windscreen wipers on cars, in which case a flexible hose **48** would be connected with the intake manifold of the engine to provide the necessary vacuum for operating the piston **45**.

Under the influence of the double-acting motor **47**, the piston **30** of the pump has a reciprocatory movement in the working chamber **29**. Movement of the piston towards the left in **Fig.7** tends to compress the vaporous mixture in the working chamber between the end of the piston and the inlet from pipe **17**, and causes valve **35** to be forced tightly against the inlet opening. In a like manner, valves **32** and **34** are forced open and the vaporous mixture in that portion of the working chamber is forced through the inlet **31** in the end of the piston **30**, into the interior of the piston, where it displaces the vaporous mixture there and forces it into the space between the right-hand end of the piston and the right-hand end of the working chamber. The passage of the vaporous mixture into the right-hand end of the working chamber is supplemented by the partial vacuum created there when the piston moves to the left. During such movement of the piston, valve **37** is maintained closed and prevents any sucking back of the vaporous mixture from the secondary heating chamber **21**.

When motor **47** reverses, piston **30** moves to the right and the vaporous mixture in the right-hand end of the working chamber is forced past valve **37** through pipe **19** into the secondary heating chamber **21**. At the same time, a vacuum is created behind piston **30** which results in the left-hand end of the working chamber being filled again with the vaporous mixture from the primary heating chamber **2**.

As the operation of pump **47** varies in accordance with the suction created in the intake manifold, it should be regulated so that the vaporous mixture is pumped into the secondary heating chamber at a rate sufficient to maintain a greater pressure there than is needed. In order that the pressure in the working chamber may at all times be maintained at the optimum, a pipe **50** having an adjustable pressure-regulating valve **51** is connected between the inlet and outlet pipes **17** and **19**. Valve **51** will permit a portion of the vaporous mixture discharged

from the pump to be bypassed to inlet **17** so that a pressure predetermined by the seating of valve **51** will at all times be maintained in the second heating chamber **21**.

Air tube **22** is provided with a butterfly throttle valve **52** and a choke valve **53**, as is usual with carburettors adapted for use with internal combustion engines. Operating stems **54**, **55** and **56** for valves **52**, **53** and **24** respectively, extend through casing **26**. An operating arm **57** is rigidly secured to the outer end of stem **55** and is connected to a rod **58** which extends to the dashboard of the car, or some other place convenient to the driver. The outer end of stem **56** of valve **24** which controls outlet **23** from the secondary heating chamber **21** has one end of an operating arm **59** fixed securely to it. The other end is pivotally connected to link **60** which extends downwards and pivotally connects to one end of a bell crank lever **61**, rigidly attached to the end of stem **54** of throttle valve **52**. The other end of the bell crank lever is connected to an operating rod **62** which, like rod **58**, extends to a place convenient to the driver. Valves **24** and **52** are connected for simultaneous operation so that when the throttle valve **52** is opened to increase the speed of the engine, valve **24** will also be opened to admit a larger amount of the heated vaporous mixture from the secondary heating chamber **21**.

While the suction created by pump **18** ordinarily will create a sufficient vacuum in the primary heating chamber **2** to cause air to be drawn into and upwards through the body of liquid fuel in the bottom of vaporising chamber **1**, in some instances it may be desirable to provide supplemental means for forcing the air into and up through the liquid, and in such cases an auxiliary pump may be provided for that purpose, or the air conduit **4** may be provided with a funnel-shaped intake which is positioned behind the engine fan **63** which is customarily placed behind the engine radiator.

The foregoing description has been given in connection with a downdraft type of carburettor, but it is to be understood that the invention is not limited to use with such type of carburettors and that the manner in which the mixture of air and vapour is introduced into the engine cylinders is immaterial as far as the advantages of the carburettor are concerned.

Before the carburettor is put into use, the pressure-regulating valve **51** in the bypass pipe **50** will be adjusted so that the pressure best suited to the conditions under which the engine is to be operated, will be maintained in the secondary heating chamber **21**. When valve **51** has thus been set and the engine started, pump **18** will create a partial vacuum in the primary heating chamber **2** and cause air to be drawn through conduit **4** to bubble upwards through the liquid fuel in the bottom of the vaporising and atomising chamber **1** with the resulting vaporisation of a part of the liquid fuel. At the same time, pump **7** will be set into operation and liquid fuel will be pumped from the fuel tank through the nozzles **9** which results in an additional amount of the fuel being vaporised. The vapour resulting from such atomisation of the liquid fuel and the passage of air through the body of the liquid, will pass into and through spiral chamber **1** where they will be heated by the products of combustion in the surrounding chamber formed by casing **26**. The fuel vapour and air will gradually pass inwards through outlet **16** and through conduit **17** to pump **18** which will force them into the secondary heating chamber **21** in which they will be maintained at the predetermined pressure by the pressure-regulating valve **51**. The vaporous mixture is further heated in chamber **21** and passes spirally outward to the valve-controlled outlet **23** which opens into air tube **22** which conducts the main volume of air to the intake manifold of the engine.

The heating of the vaporous mixture in the heating chambers **2** and **21**, tends to cause them to expand, but expansion in chamber **21** is prevented due to the pressure regulating valve **51**. However, as soon as the heated vaporous mixture passes valve **24** and is introduced into the air flowing through intake tube **22**, it is free to expand and thereby become relatively light so that a more intimate mixture with the air is obtained prior to the mixture being exploded in the engine cylinders. Thus it will be seen that the present invention not only provides means wherein the vaporous mixture from heating chamber **21** is forced into the air passing through air tube **22** by a positive force, but it is also heated to such an extent that after it leaves chamber **21** it will expand to such an extent as to have a density less than it would if introduced directly from the vaporising and atomising chamber **1** into the air tube **22**.

The majority of the liquid particles entrained by the vaporous mixture leaving chamber **1** will be separated in the first half of the outermost spiral of the primary heating chamber **2** and drained back into the body of liquid fuel in tank **1**. Any liquid particles which are not thus separated, will be carried on with the vaporous mixture and due to the circulation of that mixture and the application of heat, will be vaporised before the vaporous mixture is introduced into the air tube **22** from the secondary heating chamber **21**. Thus only "dry" vapour is introduced into the engine cylinders and any burning in the engine cylinders of liquid particles of the fuel, which would tend to raise the engine temperature above its most efficient level, is avoided.

While the fullest benefits of the invention are obtained by using both a primary and secondary heating chamber, the primary heating chamber may, if desired, be eliminated and the vaporous mixture pumped directly from the vaporising and atomising chamber **1** into the spiral heating chamber **21**.

From the foregoing description it will be seen that the present invention provides an improvement over the carburettor disclosed in my Patent No. 1,997,497, in that it is possible to maintain the vaporous mixture in the heating chamber **21** under a predetermined pressure, and that as soon as the vaporous mixture is introduced into the main supply of air passing to the intake manifold of the engine, it will expand and reach a density at which it will form a more intimate mixture with the air. Furthermore, the introduction of the vaporous mixture into the air stream in the tube **22**, causes a certain amount of turbulence which also tends to give a more intimate mixture of vapour molecules with the air.

The High MPG Carburettor of Ivor Newberry

US Patent 2,218,922

22nd October 1940

Inventor: Ivor B. Newberry

VAPORIZER FOR COMBUSTION ENGINES

This patent describes a carburettor design which was able to produce very high mpg figures using the gasoline available in the USA in the 1930s but which is no longer available as the oil industry does not want functional high mpg carburettors to be available to the public.

DESCRIPTION

This invention relates to fuel vaporising devices for combustion engines and more particularly, is concerned with improvements in devices of the kind where provision is made for using the exhaust gasses of the engines as a heating medium to aid in the vaporisation of the fuel.

One object of the invention is to provide a device which will condition the fuel in such a manner that its potential energy may be fully utilised, thereby ensuring better engine performance and a saving in fuel consumption, and preventing the formation of carbon deposits in the cylinders of the engine and the production of carbon monoxide and other objectionable gasses.

A further object is to provide a device which is so designed that the fuel is delivered to the cylinders of the engine in a highly vaporised, dry and expanded state, this object contemplating a device which is available as an exhaust box in which the vaporisation and expansion of the liquid components is effected at sub-atmospheric pressures and prior to their being mixed with the air component.

A still further object is to provide a device which will condition the components of the fuel in such a manner that they be uniformly and intimately mixed without the use of a carburettor.

A still further object is to provide a device which will enable the use of various inferior and inexpensive grades of fuel.

DESCRIPTION OF THE DRAWINGS

Fig.1 is an elevational view of the device as applied to the engine of a motor vehicle.

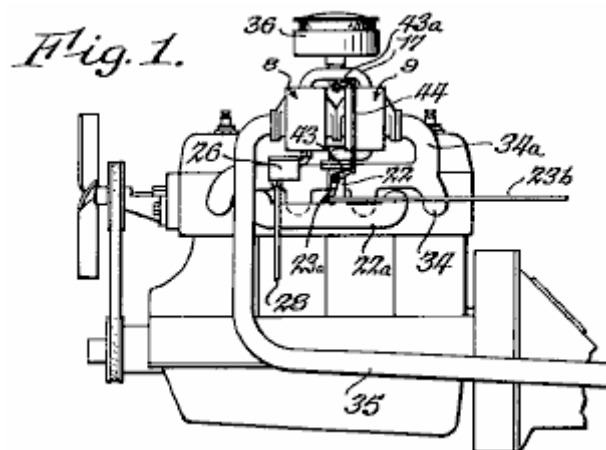

Fig.2 is an enlarged view of the device, partially in elevation and partially in section.

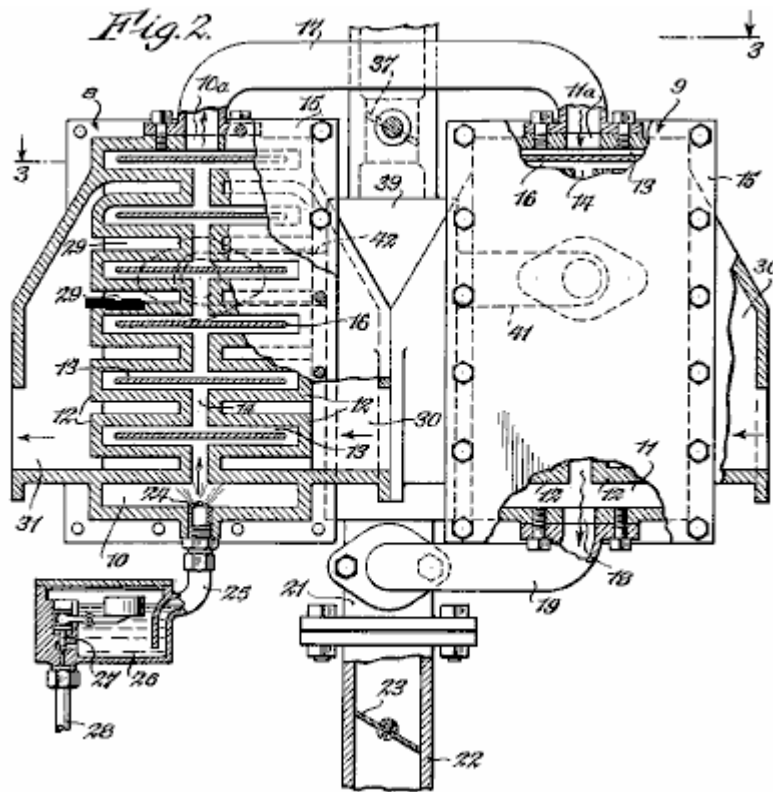

Fig.3 is a section taken along line 3--3 of Fig.2

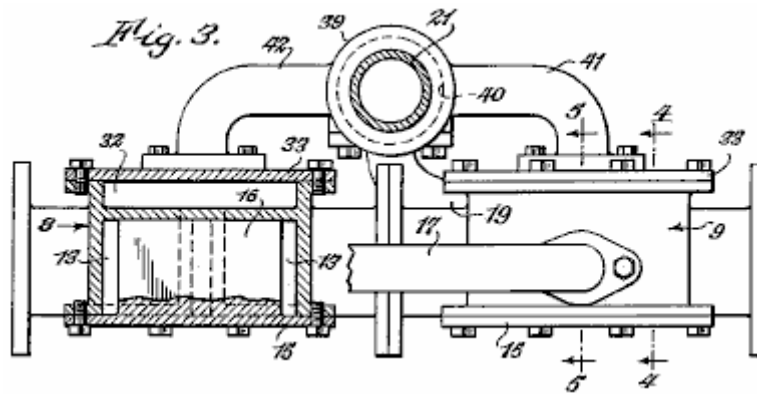

Fig.4 is a section taken along line 4--4 of Fig.3

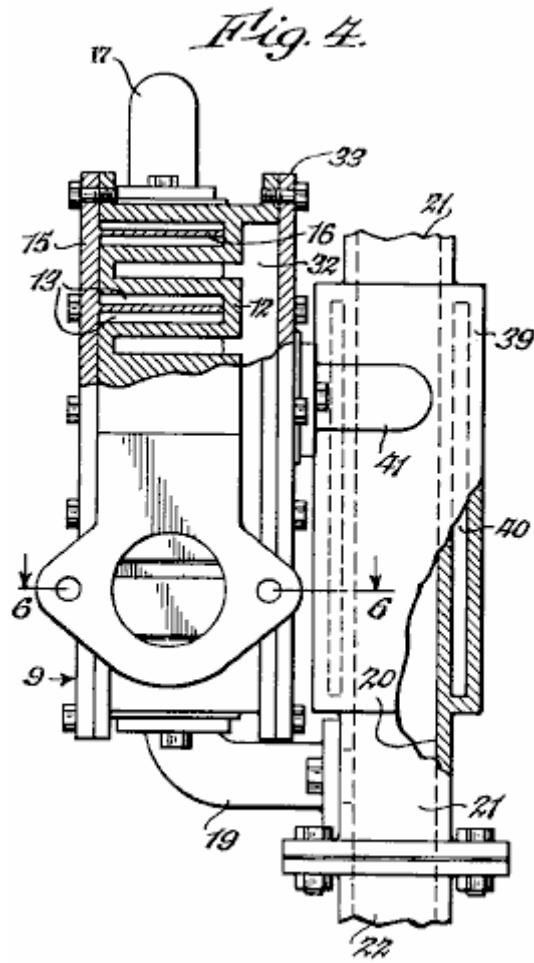

Fig.5 is a fragmentary section taken along line 5--5 of Fig.3

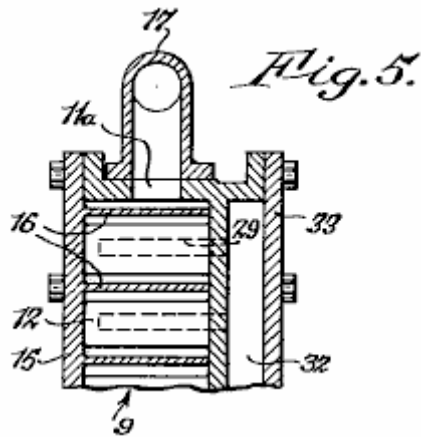
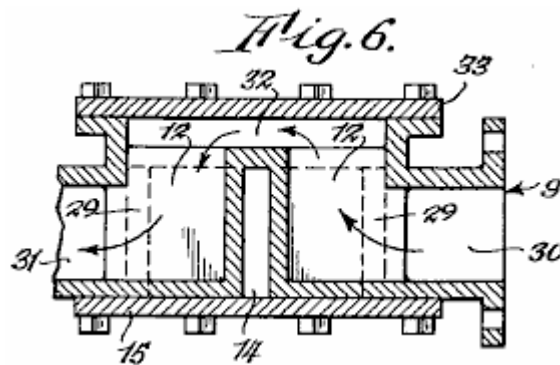

Fig.6 is a section taken along line 6--6 of Fig.4



DESCRIPTION

The device as illustrated, includes similar casings 8 and 9 which are secured together as a unit and which are formed to provide vaporising chambers 10 and 11, respectively, it being understood that the number of casings may be varied. Two series of ribs 12 are formed in each of the vaporising chambers, the ribs of each series being spaced from one another so as to provide branch passages 13 and being spaced from the ribs of the adjacent series to provide main passages 14 with which the branch passages communicate.

The vaporising chambers are closed by cover plates 15. The cover plates carry baffles 16 which are supported in the spaces between the ribs 12. The baffles extend across the main passages 14 and into, but short of the ends of the branch passages 13 to provide tortuous paths. Outlet 10a of chamber 10 is connected by conduit 17 to inlet 11a of chamber 11. Outlet 18 of chamber 11, is connected by conduit 19 with mixing chamber 20 which is located at the lower end of pipe 21 which in turn is connected to an extension 22 of the intake manifold 22a of the engine. Extension 22 contains a valve 23 which is connected by a lever 23a (Fig.1) and rod 23b to a conventional throttle (not shown).

The liquid fuel is introduced into the vaporising chamber 10 through nozzle 24 which is connected by pipe 25 to a reservoir 26 in which the fuel level is maintained by float-controlled valve 27, the fuel being supplied to the reservoir through pipe 28.

In accordance with the invention, ribs 12 are hollow, each being formed to provide a cell 29. The cells in one series of ribs open at one side into an inlet chamber 30, while the cells of the companion series open at one side into an outlet chamber 31. The cells of both series of ribs open at their backs into a connecting chamber 32 which is located behind the ribs and which is closed by a cover plate 33. Casings 8 and 9 are arranged end-to-end so that the outlet chamber of 9 communicates with the inlet chamber of 8, the gasses from the exhaust manifold 34 being introduced into the inlet chamber of casing 9 through extension 34a. The exhaust gasses enter the series of cells at the right hand side of the casing, pass through the cells into the connecting chamber at the rear and then enter the inlet chamber of casing 8. They pass successively through the two series of cells and enter exhaust pipe 35. The exhaust gasses leave the outlet chamber 31, and the path along which they travel is clearly shown by the arrows in Fig.6. As the gasses pass through casings 8 and 9, their speed is reduced to such a degree that an exhaust box (muffler) or other silencing device is rendered unnecessary.

It will be apparent that when the engine is operating a normal temperature, the liquid fuel introduced into chamber 10 will be vaporised immediately by contact with the hot walls of ribs 12. The vapour thus produced is divided into two streams, one of which is caused to enter each of the branch passages at one side of the casing and the other is caused to enter each of the branch passages at the opposite side of the casing. The two streams of vapour merge as they pass around the final baffle and enter conduit 17, but are again divided and heated in a similar manner as they flow through casing 9. Each of the vapour streams is constantly in contact with the highly heated walls of ribs 12. This passage of the vapour through the casings causes the vapour to be heated to such a degree that a dry highly-vaporised gas is produced. In this connection, it will be noted that the vaporising chambers are maintained under a vacuum and that vaporisation is effected in the absence of air. Conversion of the liquid into highly expanded vapour is thus ensured. The flow of the exhaust gasses through casings 8 and 9 is in the opposite direction to the flow of the vapour. The vapour is heated in stages and is introduced into chamber 20 at its highest temperature.

The air which is mixed with the fuel vapour, enters pipe 21 after passing through a conventional filter 36, the amount of air being regulated by valve 37. The invention also contemplates the heating of the air prior to its entry into mixing chamber 20. To this end, a jacket 39 is formed around pipe 21. The jacket has a chamber 40 which communicates with chamber 32 of casing 9 through inlet pipe 41 and with the corresponding chamber of casing 8

through outlet pipe **42**. A portion of the exhaust gasses is thus caused to pass through chamber **40** to heat the air as it passes through conduit **21** on its way to the mixing chamber. Valve **37** is connected to valve **23** by arms **43** and **43a** and link **44** so that the volume of air admitted to the mixing chamber is increased proportionately as the volume of vapour is increased. As the fuel vapour and air are both heated to a high temperature and are in a highly expanded state when they enter the mixing chamber, they readily unite to provide a uniform mixture, the use of a carburettor or similar device for this purpose being unnecessary.

From the foregoing it will be apparent that the components of the fuel mixture are separately heated prior to their entry into mixing chamber **20**. As the vapour which is produced is dry (containing no droplets of liquid fuel) and highly expanded, complete combustion is ensured. The potential energy represented by the vapour may thus be fully utilised, thereby ensuring better engine performance and a saving in fuel consumption. At the same time, the formation of carbon deposits in the combustion chambers and the production of carbon monoxide and other objectionable exhaust gasses is prevented. The device has the further advantage that, owing to the high temperature to which the fuel is heated prior to its admission into the combustion chambers, various inferior and inexpensive grades of fuel may be used with satisfactory results.

The High MPG Carburettor of Robert Shelton

US Patent 2,982,528

2nd May 1940

Inventor: Robert S. Shelton

VAPOUR FUEL SYSTEM

This patent describes a carburettor design which was able to produce very high mpg figures using the gasoline available in the USA in the 1930s but which is no longer available as the oil industry does not want functional high mpg carburettors to be available to the public.

DESCRIPTION

This invention relates to improvements in vapour fuel systems which are to be used for internal combustion engines.

An object of this invention is to provide a vapour fuel system which will provide a great saving in fuel since approximately eight times the mileage that is obtained by the conventional combustion engine, is provided by the use of this system.

Another object of the invention is to provide a vapour fuel system which is provided with a reservoir to contain liquid fuel which is heated to provide vapour from which the internal combustion engine will operate.

With the above and other objects and advantages in view, the invention consists of the novel details of construction, arrangement and combination of parts more fully described below, claimed and illustrated in the accompanying drawings.

DESCRIPTION OF THE DRAWINGS

Fig.1 is an elevational view of a vapour fuel system embodying the invention.

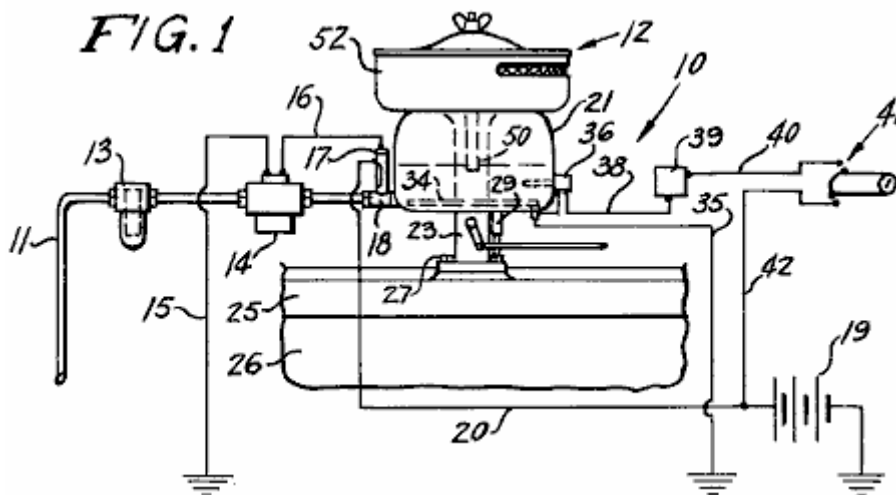

Fig.2 is an enlarged view, partly in section, showing the carburettor forming part of the system shown in Fig.1.

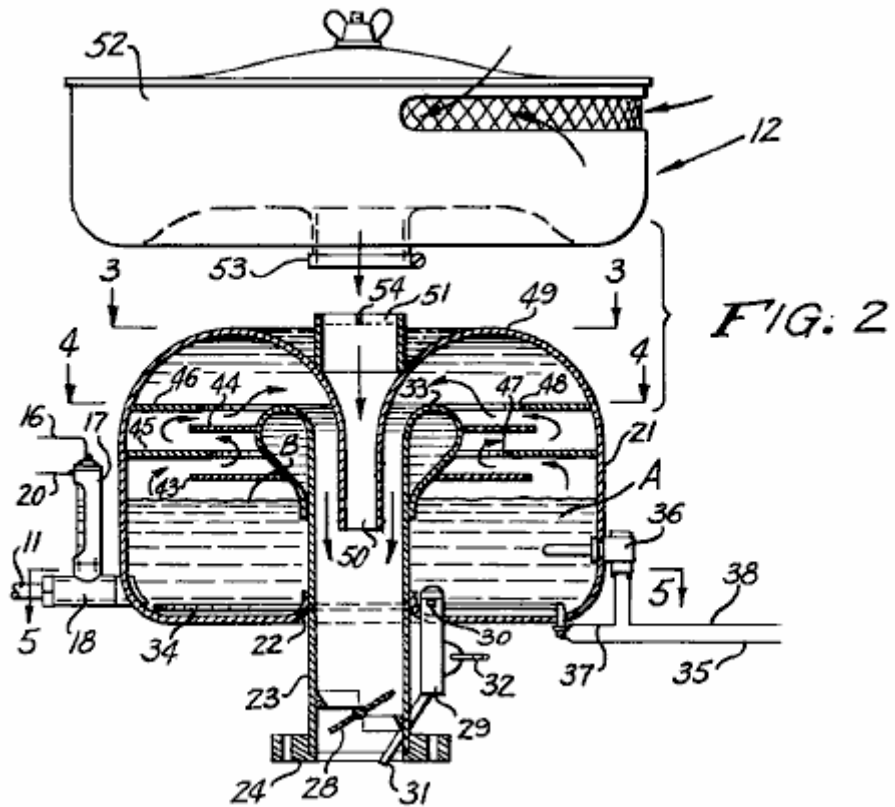

Fig.3 is a transverse sectional view on line 3--3 of Fig.2

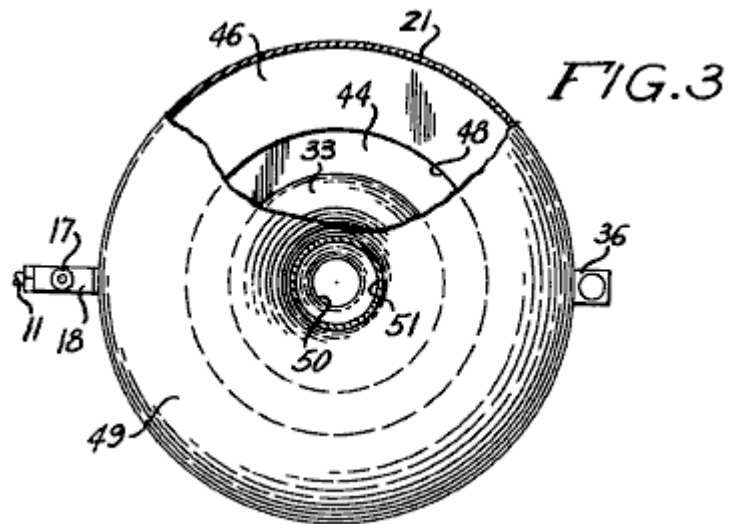

Fig.4 is a transverse sectional view on line 4--4 of Fig.2

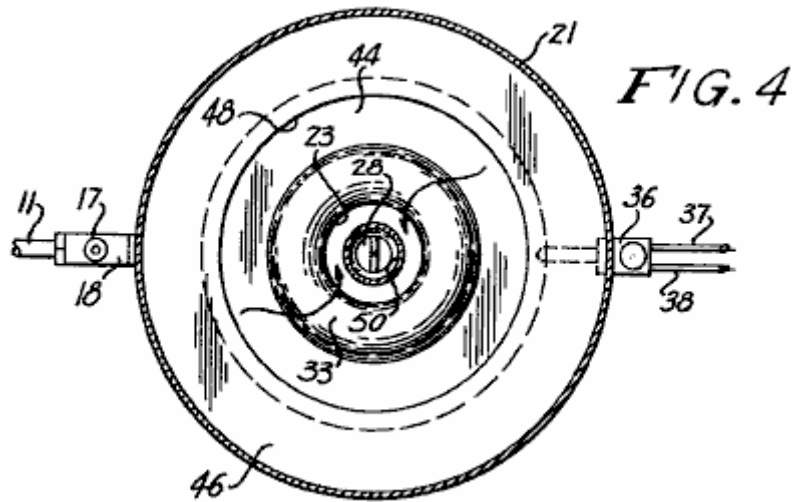
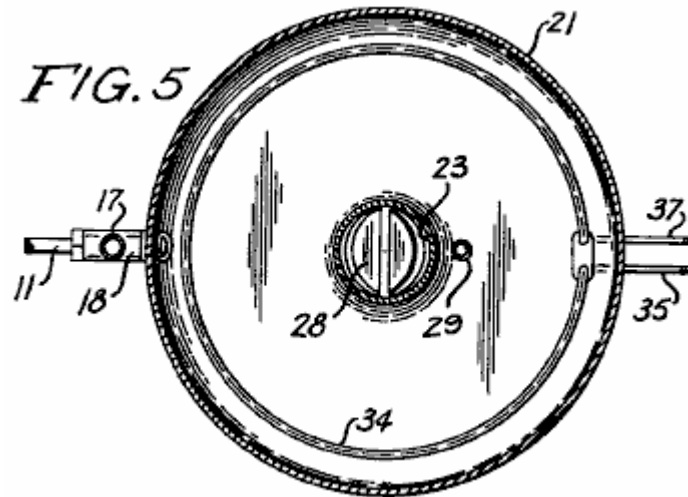

Fig.5 is a transverse sectional view on line 5--5 of Fig.2



The reference numbers used in the drawings always refer to the same item in each of the drawings. The vapour fuel system 10 includes a conduit 11 which is connected to the fuel tank at one end and to a carburettor 12 at the opposite end. In conduit 11 there is a fuel filter 13 and an electric fuel pump 14. Wire 15 grounds the pump and wire 16 connects the pump to a fuel gauge 18 on which is mounted a switch 17 which is connected to a battery 19 of the engine by wire 20.

The fuel gauge/switch is of conventional construction and is of the type disclosed in US Patents No. 2,894,093, No. 2,825,895 and No. 2,749,401. The switch is so constructed that a float in the liquid in the gauge, opens a pair of contacts when the liquid rises and this cuts off the electric pump 14. As the float lowers due to the consumption of the liquid fuel in the body, the float falls, closing the contacts and starting pump 14 which replenishes the liquid fuel in the body.

Carburettor 12 includes a dome-shaped circular bowl or reservoir 21 which is provided with a centrally located flanged opening 22 whereby the reservoir 21 is mounted on a tubular throat 23. An apratured collar 24 on the lower end of throat 23 is positioned on the intake manifold 25 of an internal combustion engine 26 and fastenings 27 secure the collar to the manifold in a fixed position.

A vapour control butterfly valve 28 is pivotally mounted in the lower end of throat 23 and valve 28 controls the entrance of the vapour into the engine and so controls its speed.

A fuel pump 29, having an inlet 30, is mounted in the bottom of the reservoir 21 so that the inlet 30 communicates with the interior of the reservoir. A spurt or feed pipe 31 connected to pump 29 extends into throat 23 so that by means of a linkage 32 which is connected to pump 29 and to a linkage for control valve 28 and the foot throttle of the engine, raw fuel may be forced into throat 23 to start the engine when it is cold.

The upper end of throat **23** is turned over upon itself to provide a bulbous hollow portion **33** within reservoir **21**. An immersion heater **34** is positioned in the bottom of the reservoir and wire **35** grounds the heater. A thermostat **36** is mounted in the wall of the reservoir and extends into it. Wire **37** connects the thermostat to heater **34** and wire **38** connects the thermostat to the thermostat control **39**. Wire **40** connects the control to the ignition switch **41** which in turn is connected to battery **19** via wires **20** and **42**.

A pair of relatively spaced parallel perforated baffle plates **43** and **44**, are connected to the bulbous portion **33** on the upper end of throat **23**, and a second pair of perforated baffle plates **45** and **46** extend inwards from the wall of reservoir **21** parallel to each other and parallel to baffle plates **43** and **44**.

The baffle plates are arranged in staggered relation to each other so that baffle plate **45** is between baffle plates **43** and **44** and baffle plate **46** extends over baffle plate **44**.

Baffle plate **45** has a central opening **47** and baffle plate **46** has a central opening **48** which has a greater diameter than opening **47**. The domed top **49** of reservoir **21**, extends into a tubular air intake **50** which extends downwards into throat **23** and a mounting ring **51** is positioned on the exterior of the domed top, vertically aligned with intake **50**. An air filter **52** is mounted on the mounting ring **51** by a coupling **53** as is the usual procedure, and a spider **54** is mounted in the upper end of mounting ring **51** to break up the air as it enters ring **51** from air filter **52**.

In operation, with carburettor **12** mounted on the internal combustion engine instead of a conventional carburettor, ignition switch **41** is turned on. Current from battery **19** will cause pump **14** to move liquid fuel into reservoir **21** until float switch **18** cuts the pump off when the liquid fuel **A** has reached level **B** in the reservoir. The control **39** is adjusted so that thermostat **36** will operate heater **34** until the liquid fuel has reached a temperature of 105⁰ F at which time heater **34** will be cut off. When the liquid fuel has reached the proper temperature, vapour will be available to follow the course indicated by the arrows in **Fig.2**.

The engine is then started and if the foot control is actuated, pump **29** will cause raw liquid fuel to enter the intake manifold **25** until the vapour from the carburettor is drawn into the manifold to cause the engine to operate. As the fuel is consumed, pump **14** will again be operated and heater **34** will be operated by thermostat **36**. Thus, the operation as described will continue as long as the engine is operating and the ignition switch **41** is turned on. Reservoir **21** will hold from 4 to 6 pints (2 to 4 litres) of liquid fuel and since only the vapour from the heated fuel will cause the carburettor **12** to run the engine, the engine will operate for a long time before more fuel is drawn into reservoir **21**.

Baffles **43**, **44**, **45** and **46** are arranged in staggered relation to prevent splashing of the liquid fuel within the carburettor. The level **B** of the fuel in reservoir **21** is maintained constant by switch **18** and with all elements properly sealed, the vapour fuel system **10** will operate the engine efficiently.

Valve **28** controlling the entrance of vapour into intake manifold **25**, controls the speed of the engine in the same manner as the control valve in a conventional carburettor.

There has thus been described a vapour fuel system embodying the invention and it is believed that the structure and operation of it will be apparent to those skilled in the art. It is also to be understood that changes in the minor details of construction, arrangement and combination of parts may be resorted to provided that they fall within the spirit of the invention.

The High MPG Carburettor of Harold Schwartz

US Patent 3,294,381

27th December 1966

Inventor: Harold Schwartz

CARBURETTOR

This patent describes a carburettor design which was able to produce very high mpg figures using the gasoline available in the USA at the time but which is no longer available as the oil industry does not want functional high mpg carburettors to be available to the public.

DESCRIPTION

This invention relates to a carburettor construction. An object of the present invention is to provide a carburettor in which the fuel is treated by the hot exhaust fumes of an engine before being combined with air and being fed into the engine.

Another object of the invention is to provide a carburettor as characterised above, which circulates the fume-laden fuel in a manner to free it of inordinately large globules of fuel, thereby insuring that only finely divided and pre-heated fuel of mist-like consistency is fed to the intake manifold of the engine.

The present carburettor, when used for feeding the six-cylinder engine of a popular car, improved the miles per gallon performance under normal driving conditions using a common grade of fuel, by over 200%. This increased efficiency was achieved from the pre-heating of the fuel and keeping it under low pressure imposed by suction applied to the carburettor for the purpose of maintaining the level of fuel during operation of the engine. This low pressure in the carburettor causes increased vaporisation of the fuel in the carburettor and raises the efficiency of operation.

This invention also has for its objects; to provide a carburettor which is positive in operation, convenient to use, easily installed in its working position, easily removed from the engine, economical to manufacture, of relatively simple design and of general superiority and serviceability.

The invention also comprises novel details of construction and novel combinations and arrangements of parts, which will appear more fully in the course of the following description and which is based on the accompanying drawings. However, the drawings and following description merely describes one embodiment of the present invention, and are only given as an illustration or example.

DESCRIPTION OF THE DRAWINGS

In the drawings, all reference numbers apply to the same parts in each drawing.

Fig.1 is a partly broken plan view of a carburettor constructed in accordance with the present invention, shown with a fuel supply, feeding and return system.

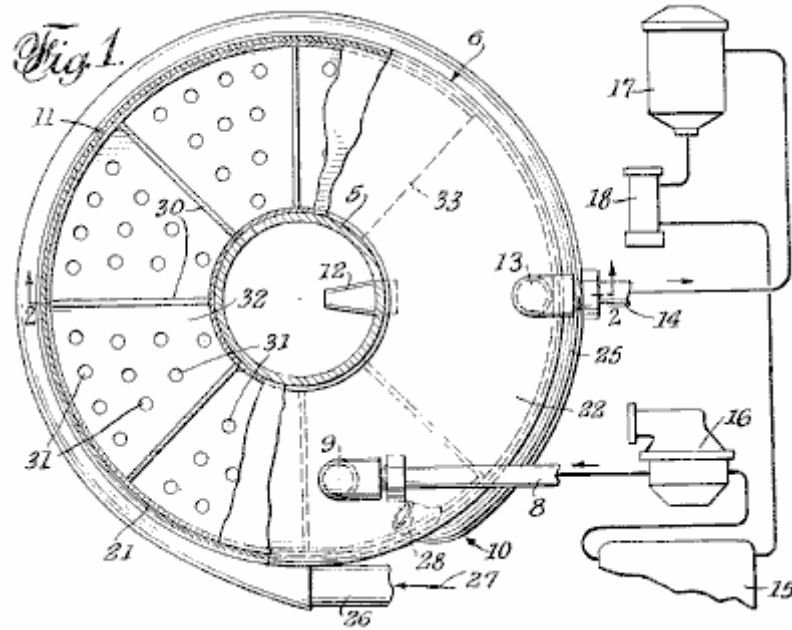

Fig.2 is a vertical sectional view of the carburettor taken on the plane of line 2--2 in Fig.1

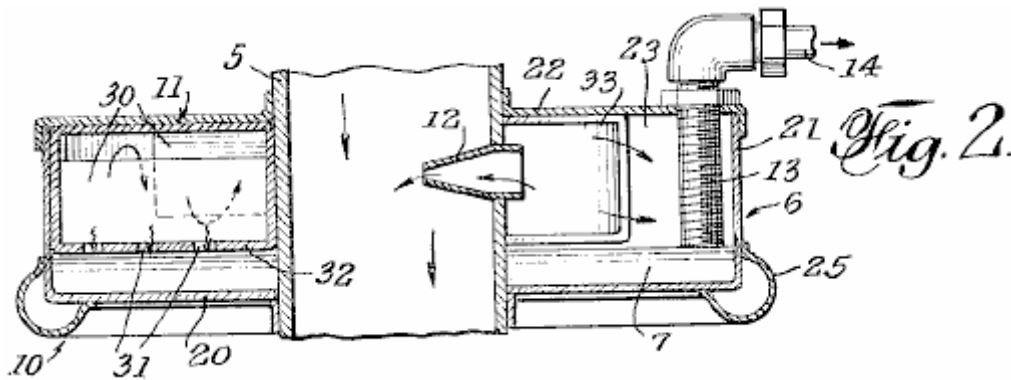
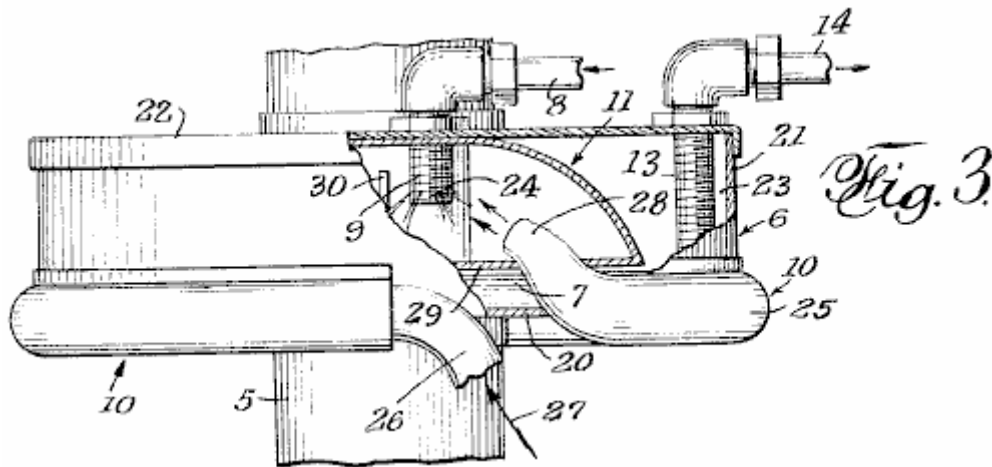

Fig.3 is a partial side elevation and partial sectional view of the carburettor, showing additional structural details



The carburettor is preferably mounted on the usual downdraft air tube **5** which receives a flow of air through the air filter. Tube **5** is provided with a throttle or butterfly valve which controls the flow and incorporates a flow-increasing venturi passage. These common features of the fuel feed to the engine intake manifold are not shown since these features are well known and they are also disclosed in my pending Patent application Serial No.

182,420 now abandoned. The present carburettor embodies improvements over the disclosure of the earlier application.

The present carburettor comprises a housing **6** mounted on air tube **5**, and designed to hold a shallow pool of fuel **7**, a fuel inlet **8** terminating in a spray nozzle **9**, an exhaust gas manifold **10** to conduct heated exhaust gasses for discharge into the spray of fuel coming out of nozzle **9** and for heating the pool of fuel **7** underneath it. Means **11** to scrub the fuel-fumes mixture to eliminate large droplets of fuel from the mixture (the droplets fall into pool **7** underneath), a nozzle tube **12** to receive the scrubbed mixture and to pass the mixture under venturi action into air tube **5** where it is combined with air and made ready for injection into the intake manifold of the engine. Pickup pipe **13** is connected to an outlet **14** for drawing excess fuel from pool **7** during operation of the carburettor.

The system connected to the carburettor is shown in **Fig.1**, and comprises a fuel tank **15**, a generally conventional fuel pump **16** for drawing fuel from the tank and directing it to inlet **8**, a fuel filter **17**, and a pump **18** connected in series between the fuel tank and outlet **14** to place pipe **13** under suction and to draw excess fuel from the carburettor back to tank **15** for re-circulation to inlet **8**.

Carburettor housing **6** may be circular, as shown and quite flat compared to its diameter, so as to have a large flat bottom **20** which, with the cylindrical wall **21**, holds the fuel pool **7**. Cover **22** encloses the top of the housing. The bottom **20** and cover **22** have aligned central openings through which the downdraft tube **5** extends, this pipe forming the interior of the housing, creating an annular inner space **23**.

The fuel inlet **8** is attached to cover **22** by a removable connection. Spray nozzle **9** extends through the cover. While the drawing shows spray-emitting holes **24** arranged to provide a spray around nozzle **9**, the nozzle may be formed so that the spray is directional as desired to achieve the most efficient interengagement of the sprayed fuel with the heating gasses supplied by the manifold **10**.

The manifold is shown as a pipe **25** which has an end **26** extending from the conventional heat riser chamber (not shown) of the engine, the arrow **27** indicating exhaust gas flow into pipe **25**. The pipe may encircle the lower portion of the housing **6**, to heat the pool of fuel **7** by transfer of heat through the wall of the housing. The manifold pipe is shown with a discharge end **28** which extends into the housing in an inward and upward direction towards nozzle **9** so that the exhaust gasses flowing in the pipe intermingle with the sprayed fuel and heat it as it leaves the nozzle.

The fuel-scrubbing means **11** is shown as a curved chamber **29** located inside housing **6**, provided with a series of baffle walls **30** which cause the fumes-heated fuel mist to follow a winding path and intercept the heavier droplets of fuel which then run down the faces of the baffle walls, through openings **31** in the bottom wall **32** of scrubbing chamber **29** into the interior space **23** of housing **6** above the level of the fuel pool **7**.

Pickup pipe **13** is also shown as carried by housing cover **22** and may be adjusted so that its lower open end is so spaced from the housing bottom **20** as to regulate the depth of pool **7**, which is preferably below the bottom wall **32** of the scrubbing chamber **29**. Since this pipe is subject to the suction of pump **18** through outlet **14** and filter **17**, the level of pool **7** is maintained by excess fuel being returned to tank **15** by pump **16**.

It will be seen that the surface of pool **7** is subject not only to the venturi action in tube **5**, but also to the suction of pump **18** as it draws excess fuel back to fuel tank **15**. Thus, the surface of the pool is under somewhat less than atmospheric pressure which increases the rate of vaporisation from the pool surface, the resulting vapour combining with the flow from the scrubbing chamber to the downdraft tube **5**.

While this description has illustrated what is now contemplated to be the best mode of carrying out the invention, the construction is, of course, subject to modification without departing from the spirit and scope of the invention. Therefore, it is not desired to restrict the invention to the particular form of construction illustrated and described, but to cover all modifications which may fall within its scope.

The High MPG Carburettor of Oliver Tucker

US Patent 3,653,643

4th April 1972

Inventor: Oliver M. Tucker

CARBURETTOR

This patent describes a carburettor design which was able to produce very high mpg figures using the gasoline available in the USA at the time but which is no longer available as the oil industry does not want functional high mpg carburettors to be available to the public.

ABSTRACT

A carburettor including a housing having a fluid reservoir in the bottom, an air inlet at the top of the housing, a delivery pipe coaxially mounted within the housing and terminating short of the top of the housing, and a porous vaporising filter substantially filling the reservoir. A baffle is concentrically mounted within the housing and extends partially into the vaporising filter in the reservoir to deflect the incoming air through the filter. The level of liquid fuel in the reservoir is kept above the bottom of the baffle, so that air entering the carburettor through the inlet must pass through the liquid fuel and vaporising filter in the reservoir before discharge through the outlet. A secondary air inlet is provided in the top of the housing for controlling the fuel air ratio of the vaporised fuel passing into the delivery pipe.

BACKGROUND OF THE INVENTION

It is generally well known that liquid fuel must be vaporised in order to obtain complete combustion. Incomplete combustion of fuel in internal combustion engines is a major cause of atmospheric pollution. In a typical automotive carburettor, the liquid fuel is atomised and injected into the air stream in a manifold of approximately 3.14 square inches in cross-sectional area. In an eight cylinder 283 cubic inch engine running at approximately 2,400 rpm requires 340,000 cubic inches of air per minute. The air velocity in the intake manifold at this engine speed will be approximately 150 feet per second and it will therefore take approximately 0.07 seconds for a particle of fuel to move from the carburettor to the combustion chamber and the fuel will remain in the combustion chamber for approximately 0.0025 seconds.

It is conceivable that in this short period of time, complete vaporisation of the fuel is not achieved and as a consequence, incomplete combustion occurs, resulting in further air pollution. The liquid fuel particles if not vaporised, can deposit on the cylinder walls and dilute the lubricating oil film there, promoting partial burning of the lubricating oil and adding further to the pollution problem. Destruction of the film of lubricating oil by combustion can also increase mechanical wear of both cylinders and piston rings.

SUMMARY OF THE INVENTION

The carburettor of this invention provides for the complete combustion of liquid fuel in an internal combustion engine, with a corresponding decrease of air pollutant in the exhaust gasses. This is achieved by supplying completely vaporised or dry gas to the combustion chamber. The primary air is initially filtered prior to passing through a vaporising filter which is immersed in liquid fuel drawn from a reservoir in the carburettor. The vaporising filter continuously breaks the primary air up into small bubbles thereby increasing the surface area available for evaporation of the liquid fuel. Secondary air is added to the enriched fuel-air mixture through a secondary air filter prior to admission of the fuel-air mixture into the combustion chambers of the engine. Initial filtration of both the primary and secondary air removes any foreign particles which may be present in the air, and which could cause increased wear within the engine. The carburettor also assures delivery of a clean dry gas to the engine due to the gravity separation of any liquid or dirt particles from the fuel-enriched primary air.

Other objects and advantages will become apparent from the following detailed description when read in conjunction with the accompanying drawing, in which the single figure shows a perspective cross-sectional view of the carburettor of this invention.

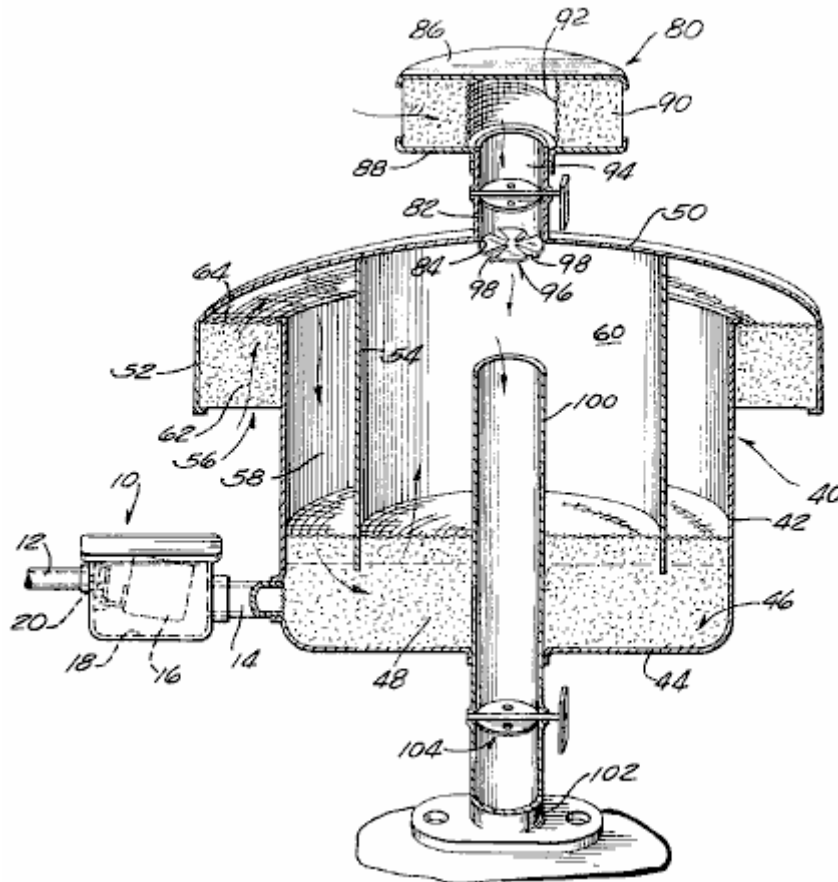

DESCRIPTION OF THE INVENTION

The carburettor **40** disclosed here is adapted for use with an internal combustion engine where air is drawn through the carburettor to vaporise the fuel in the carburettor prior to its admission to the engine.

In this regard, the flow of liquid fuel, gas or oil, to the carburettor is controlled by means of a float valve assembly **10** connected to a source of liquid fuel by fuel line **12** and to the carburettor **40** by a connecting tube **14**. The flow of liquid fuel through the float valve assembly **10** is controlled by a float **16**, pivotally mounted within a float chamber **18** and operatively connected to a float valve **20**.

In accordance with the invention, the liquid fuel admitted to the carburettor **40** through tube **14**, is completely evaporated by the primary air for the engine within the carburettor and mixed with secondary air prior to admission into a delivery tube **100** which is connected to the manifold **102** of the engine. More specifically, carburettor **40** includes a cylindrical housing or pan **42**, having a bottom wall **44** which forms a liquid fuel and filter reservoir **46**. A vaporising filter **48** is positioned within reservoir **46** and extends upwards for a distance from the bottom wall **44** of the housing **42**. The vaporising filter **48** is used to continuously break up the primary air into a large number of small bubbles as it passes through the liquid fuel in reservoir **46**. This increases the surface area per volume of air available for evaporation of the liquid fuel, as described in more detail below. This filter **48** is formed of a three-dimensional skeletal material that is washable and is not subject to breakdown under the operating conditions inside the carburettor. A foamed cellular plastic polyurethane filter having approximately 10 to 20 pores per inch has been used successfully in the carburettor.

Housing **42** is closed at the top by a hood or cover **50** which can be secured in place by any appropriate means. The hood has a larger diameter than the diameter of housing **42** and includes a descending flange **52** and a descending baffle **54**. Flange **52** is concentrically arranged and projects outwards beyond the sides of housing **42** to form a primary air inlet **56**. Baffle **54** is concentrically positioned inside housing **42** to create a primary air chamber **58** and a central mixing chamber **60**.

Primary air is drawn into housing **42** through air inlet **56** and is filtered through primary air filter **62** which is removably mounted in the space between flange **52** and the outside of the wall of housing **42** by means of a screen **64**. The primary air filter **62** can be made of the same filtering material as the vaporising filter **48**.

As the primary air enters the primary air chamber **58** it is deflected through the liquid fuel in reservoir **46** by means of the cylindrical baffle **54**. This baffle extends down from hood **50** far enough to penetrate the upper portion of the vaporising filter **48**. The primary air must pass around the bottom of baffle **54** and through both the liquid fuel and the vaporising filter **48** prior to entering the mixing chamber **60**.

The level of the liquid fuel in reservoir **46** is maintained above the bottom edge of baffle **54** by means of the float valve assembly **10**. The operation of the float valve assembly **10** is well known. Float chamber **18** is located at approximately the same level as reservoir **46** and float **16** pivots in response to a drop in the level of the liquid fuel in the float chamber and opens the float valve **20**.

One of the important features of the present invention is the efficiency of evaporation of the liquid fuel by the flow of the large number of bubbles through the reservoir. This is believed to be caused by the continual break up of the bubbles as they pass through the vaporising filter **48**. It is well known that the rate of evaporation caused by a bubble of air passing unmolested through a liquid, is relatively slow due to the surface tension of the bubble. However, if the bubble is continuously broken, the surface tension of the bubble is reduced and a continual evaporating process occurs. This phenomenon is believed to be the cause of the high evaporation rate of the liquid fuel in the carburettor of this invention.

Another feature of the carburettor of this invention is its ability to supply dry gas to the central mixing chamber **60** in housing **42**. Since the flow of primary air in the central mixing chamber **60** is vertically upwards, the force of gravity will prevent any droplets of liquid fuel from rising high enough in the carburettor to enter the delivery tube **100**. The delivery of dry gas to the delivery tube increases the efficiency of combustion and thereby reduces the amount of unburnt gasses or pollutants which are exhausted into the air by the engine.

Means are provided for admitting secondary air into the central mixing chamber **60** to achieve the proper fuel-air ratio required for complete combustion. Such means is in the form of a secondary air filter assembly **80** mounted on an inlet tube **82** provided in opening **84** in hood **50**. The secondary air filter assembly **80** includes an upper plate **86**, a lower plate **88**, and a secondary air filter **90** positioned between plates **86** and **88**. The secondary air filter **90** is prevented from being drawn into inlet tube **82** by means of a cylindrical screen **92** which forms a continuation of tube **82**. The secondary air passes through the outer periphery of the secondary air filter **90**, through screen **92** and into tube **82**. The flow of secondary air through tube **82** is controlled by means of a butterfly valve **94** as is generally understood in the art.

Complete mixing of the dry gas-enriched primary air with the incoming secondary air within housing **42**, is achieved by means of deflector **96** positioned at the end of tube **82**. Deflector **96** includes a number of vanes **98** which are twisted to provide an outwardly-deflected circular air flow into the central mixing chamber **60** and thereby creating an increase in the turbulence of the secondary air as it combines with the fuel-enriched primary air. The deflector prevents cavitation from occurring at the upper end of the outlet tube **100**.

The flow of fuel-air mixture to the engine is controlled by means of a throttle valve **104** provided in the outlet or delivery tube **100**. The operation of the throttle valve **104** and butterfly valve **94** are both controlled in a conventional manner.

THE OPERATION OF THE CARBURETTOR

Primary air is drawn into housing **42** through primary air inlet **56** and passes upwards through primary air filter **62** where substantially all foreign particles are removed from the primary air. The filtered primary air then flows downwards through primary air chamber **58**, under baffle **54**, through fuel filter reservoir **46**, and upwards into central mixing chamber **60**. All of the primary air passes through the vaporising filter **48** provided in reservoir **46**. The vaporising filter **48** continuously breaks the primary air stream into thousands of small bubbles, reducing surface tension and increasing the air surface available for evaporation of the liquid fuel. Since the outer surface of each bubble is being constantly broken up by the vaporising filter **48** and is in constant contact with the liquid fuel as the bubble passes through the vaporising filter **48**, there is a greater opportunity for evaporation of the fuel prior to entering the central mixing chamber **60**. The vertical upward flow of the fuel-enriched primary air in the central mixing chamber, ensures that no liquid fuel droplets will be carried into the delivery tube **100**.

The fuel-enriched primary air is thoroughly mixed with the secondary air entering through tube **82** by means of the deflector system **96** which increases the turbulence of the primary and secondary air within the central mixing chamber and prevents cavitation from occurring in delivery tube **100**. The completely mixed fuel-enriched primary air and the secondary air then pass through delivery tube **100** into the inlet manifold of the engine.

The High MPG Carburettor of Thomas Ogle

US Patent 4,177,779

11th December 1979

Inventor: Thomas H. Ogle

FUEL ECONOMY SYSTEM FOR AN INTERNAL COMBUSTION ENGINE

This patent describes a carburettor design which was able to produce very high mpg figures using the gasoline available in the USA at the time but which is no longer available as the oil industry does not want functional high mpg carburettors to be available to the public.

ABSTRACT

A fuel economy system for an internal combustion engine which, when installed in a motor vehicle, overcomes the need for a conventional carburettor, fuel pump and fuel tank. The system operates by using the engine vacuum to draw fuel vapours from a vapour tank through a vapour conduit to a vapour equaliser which is positioned directly over the intake manifold of the engine. The vapour tank is constructed of heavy duty steel, or the like, to withstand the large vacuum pressure and includes an air inlet valve coupled for control to the accelerator pedal. The vapour equaliser ensures distribution of the correct mixture of air and vapour to the cylinders of the engine for combustion, and also includes its own air inlet valve coupled for control to the accelerator pedal. The system utilises vapour-retarding filters in the vapour conduit, vapour tank and vapour equaliser to deliver the correct vapour/air mixture for proper operation. The vapour tank and fuel contained in it, are heated by running the engine coolant through a conduit within the tank. Due to the extremely lean fuel mixtures used by the present invention, gas mileage in excess of one hundred miles per gallon may be achieved.

BACKGROUND OF THE INVENTION

1. Field of the Invention

The present invention is related to internal combustion engines and, more particularly, is directed towards a fuel economy system for an internal combustion engine which, when applied to a motor vehicle, overcomes the need for conventional carburettors, fuel pumps and fuel tanks, and enables vastly improved fuel consumption to be achieved.

2. Description of the Prior Art

The prior art evidences many different approaches to the problem of increasing the efficiency of an internal combustion engine. Due to the rising price of fuel, and the popularity of motor vehicles as a mode of transportation, much of the effort in this area is generally directed towards improving fuel consumption for motor vehicles. Along with increased mileage, much work has been done with a view towards reducing pollutant emissions from motor vehicles.

I am aware of the following United States patents which are generally directed towards systems for improving the efficiency and/or reducing the pollutant emissions of internal combustion engines:

Chapin	1,530,882
Crabtree et al	2,312,151
Hietrich et al	3,001,519
Hall	3,191,587
Wentworth	3,221,724
Walker	3,395,681
Holzappfel	3,633,533
Dwyre	3,713,429
Herpin	3,716,040
Gorman, Jr.	3,728,092
Alm et al	3,749,376
Hollis, Jr.	3,752,134
Buckton et al	3,759,234
Kihn	3,817,233
Shih	3,851,633

Burden, Sr.	3,854,463
Woolridge	3,874,353
Mondt	3,888,223
Brown	3,907,946
Lee, Jr.	3,911,881
Rose et al	3,931,801
Reimuller	3,945,352
Harpman	3,968,775
Naylor	4,003,356
Fortino	4,011,847
Leshner et al	4,015,569
Sommerville	4,015,570

The Chapin U.S. Pat. No. 1,530,882 discloses a fuel tank surrounded by a water jacket, the latter of which is included in a circulation system with the radiator of the automobile. The heated water in the circulation system causes the fuel in the fuel tank to readily vaporise. Suction from the inlet manifold causes air to be drawn into the tank to bubble air through the fuel to help form the desired vapour which is then drawn to the manifold for combustion.

The Buckton et al U.S. Pat. No. 3,759,234 advances a fuel system which provides supplementary vapours for an internal combustion engine by means of a canister that contains a bed of charcoal granules. The Wentworth and Hietrich et al U.S. Pat. Nos. 3,221,724 and 3,001,519 also teach vapour recovery systems which utilise filters of charcoal granules or the like.

The Dwyre U.S. Pat. No. 3,713,429 uses, in addition to the normal fuel tank and carburettor, an auxiliary tank having a chamber at the bottom which is designed to receive coolant from the engine cooling system for producing fuel vapours, while the Walker U.S. Pat. No. 3,395,681 discloses a fuel evaporator system which includes a fuel tank intended to replace the normal fuel tank, and which includes a fresh air conduit for drawing air into the tank.

The Fortino U.S. Pat. No. 4,011,847 teaches a fuel supply system wherein the fuel is vaporised primarily by atmospheric air which is released below the level of the fuel, while the Crabtree et al U.S. Pat. No. 2,312,151 teaches a vaporisation system which includes a gas and air inlet port located in a vaporising chamber and which includes a set of baffles for effecting a mixture of the air and vapour within the tank. The Mondt U.S. Pat. No. 3,888,223 also discloses an evaporative control canister for improving cold start operation and emissions, while Sommerville U.S. Pat. No. 4,015,570 teaches a liquid-fuel vaporiser which is intended to replace the conventional fuel pump and carburettor that is designed to mechanically change liquid fuel to a vapour state.

While the foregoing patents evidence a proliferation of attempts to increase the efficiency and/or reduce pollutant emissions from internal combustion engines, no practical system has yet found its way to the marketplace.

OBJECTS AND SUMMARY OF THE INVENTION

It is therefore a primary object of the present invention to provide a new and improved fuel economy system for an internal combustion engine which greatly improves the efficiency of the engine.

Another object of the present invention is to provide a unique fuel economy system for an internal combustion engine which provides a practical, operative and readily realisable means for dramatically increasing the gas mileage of conventional motor vehicles.

A further object of the present invention is to provide an improved fuel economy system for internal combustion engines which also reduces the pollutant emissions.

The foregoing and other objects are attained in accordance with one aspect of the present invention through the provision of a fuel vapour system for an internal combustion engine having an intake manifold, which comprises a tank for containing fuel vapour, a vapour equaliser mounted on and in fluid communication with the intake manifold of the engine, and a vapour conduit which connect the tank to the vapour equaliser for delivering fuel vapour from the former to the latter. The vapour equaliser includes a first valve connected to it for controlling the admission of air to the vapour equaliser, while the tank has a second valve connected to it for controlling the admission of air to the tank. A throttle controls the first and second valves so that the opening of the first valve precedes and exceeds the opening of the second valve during operation.

In accordance with other aspects of the present invention, a filter is positioned in the vapour conduit to retard the flow of fuel vapour from the tank to the vapour equaliser. In a preferred form, the filter comprises carbon particles and may include a sponge-like collection of, for example, neoprene fibres. In a preferred embodiment, the filter comprises a substantially tubular housing positioned in series in the vapour conduit, the housing containing a central portion comprising a mixture of carbon and neoprene, and end portions comprising carbon, positioned on each side of the central portion.

In accordance with another aspect of the present invention, a second filter is positioned in the vapour equaliser for again retarding the flow of the fuel vapour to the engine intake manifold. The second filter is positioned downstream of the first valve and in a preferred form, includes carbon particles mounted in a pair of recesses formed in a porous support member. The porous support member, which may comprise neoprene, includes a first recessed portion positioned opposite a vapour inlet port in the vapour equaliser to which the vapour conduit is connected, while a second recessed portion is positioned opposite the intake manifold of the engine.

In accordance with still other aspects of the present invention, a third filter is positioned in the tank for controlling the flow of fuel vapour into the vapour conduit in proportion to the degree of vacuum in the tank. The filter more particularly comprises a mechanism for reducing the amount of fuel vapour delivered to the vapour conduit when the engine is idling and when the engine has attained a steady speed. The throttle acts to close the second valve when the engine is idling and when the engine has attained a steady speed, to thereby increase the vacuum pressure in the tank. In a preferred form, the third filter comprises a frame pivotally mounted within the tank and movable between first and second operating positions. The first operating position corresponds to an open condition of the second valve, while the second operating position corresponds to a closed condition of the second valve. The tank includes a vapour outlet port to which one end of the vapour conduit is connected, such that the second operating position of the frame places the third filter in communication with the vapour outlet port.

More particularly, the third filter in a preferred form includes carbon particles sandwiched between two layers of a sponge-like filter material, which may comprise neoprene, and screens for supporting the layered composition within the pivotable frame. A conduit is positioned on the third filter for placing it in direct fluid communication with the vapour outlet port when the frame is in its second operating position.

In accordance with yet other aspects of the present invention, a conduit is connected between the valve cover of the engine and the vapour equaliser for directing the oil blow-by to the vapour equaliser in order to minimise valve clatter. The tank also preferably includes a copper conduit positioned in the bottom of it, which is connected in series with the cooling system of the motor vehicle, for heating the tank and generating more vapour. A beneficial by-product of the circulating system reduces the engine operating temperature to further improve operating efficiency.

BRIEF DESCRIPTION OF THE DRAWINGS

Various objects, features and attendant advantages of the present invention will be more fully appreciated as the same become better understood from the following detailed description of the present invention when considered in connection with the accompanying drawings, in which:

Fig.1 is a perspective view illustrating the various components which together comprise a preferred embodiment of the present invention as installed in a motor vehicle;

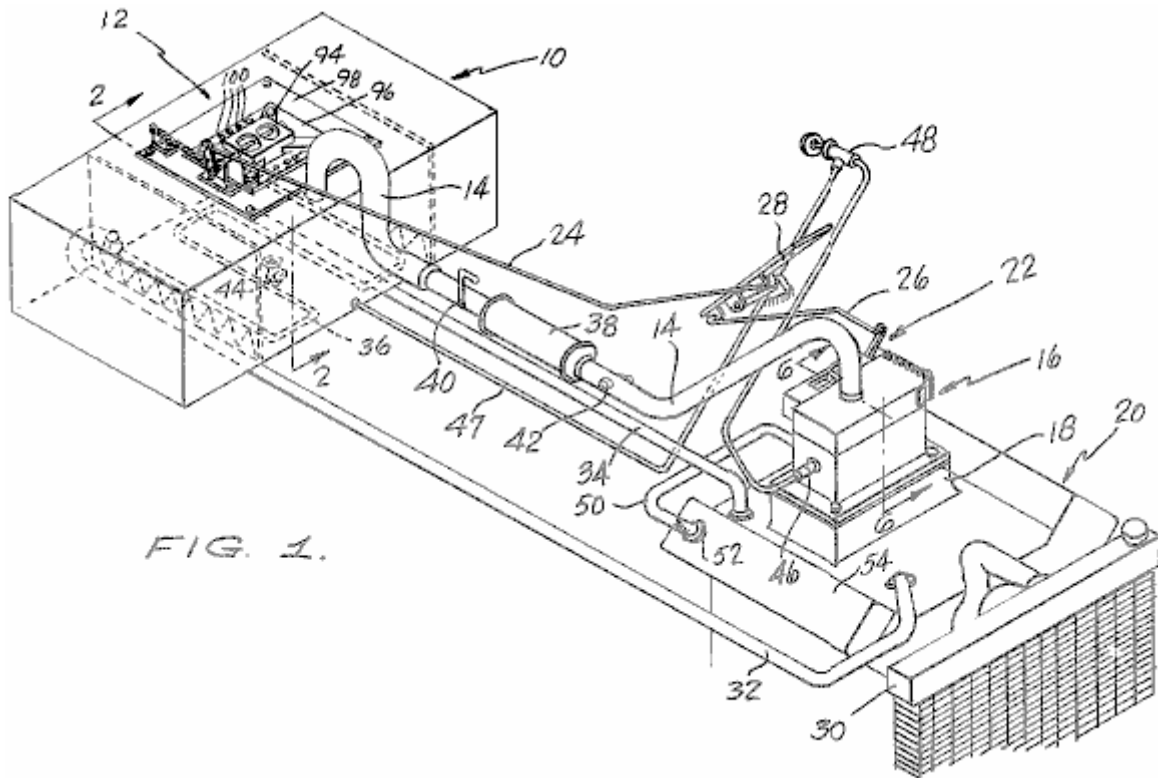

FIG. 1.

Fig.2 is a cross-sectional view of one of the components of the preferred embodiment illustrated in Fig.1 taken along line 2--2

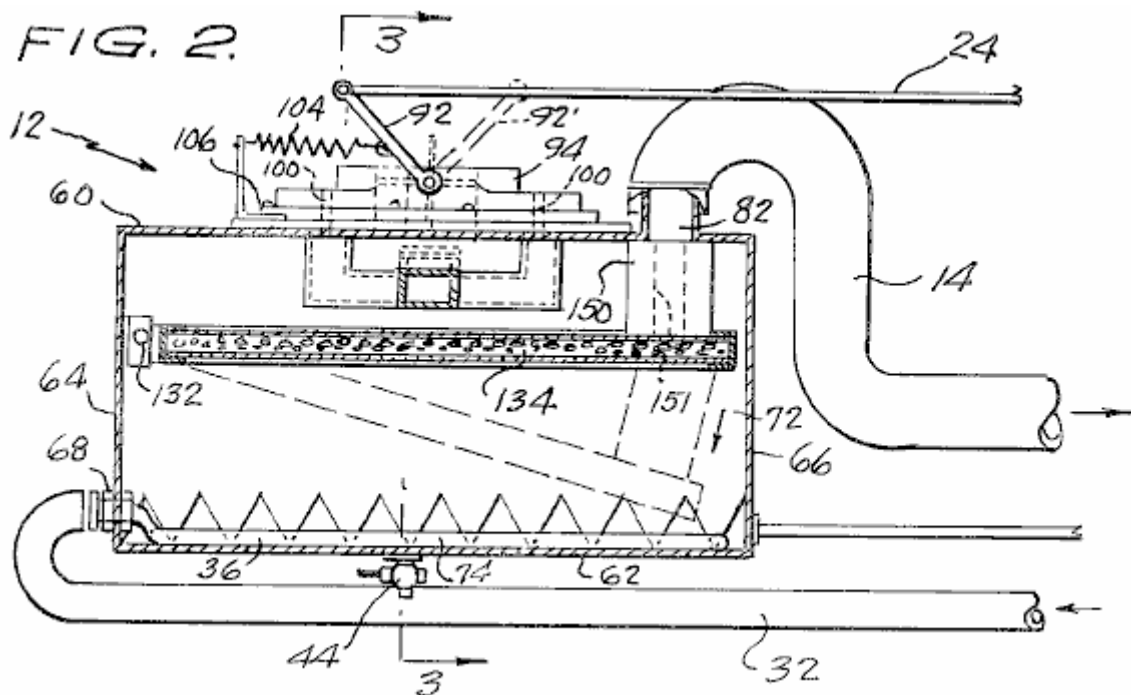

FIG. 2.

Fig.3 is a sectional view of the vapour tank illustrated in Fig.2 taken along line 3--3

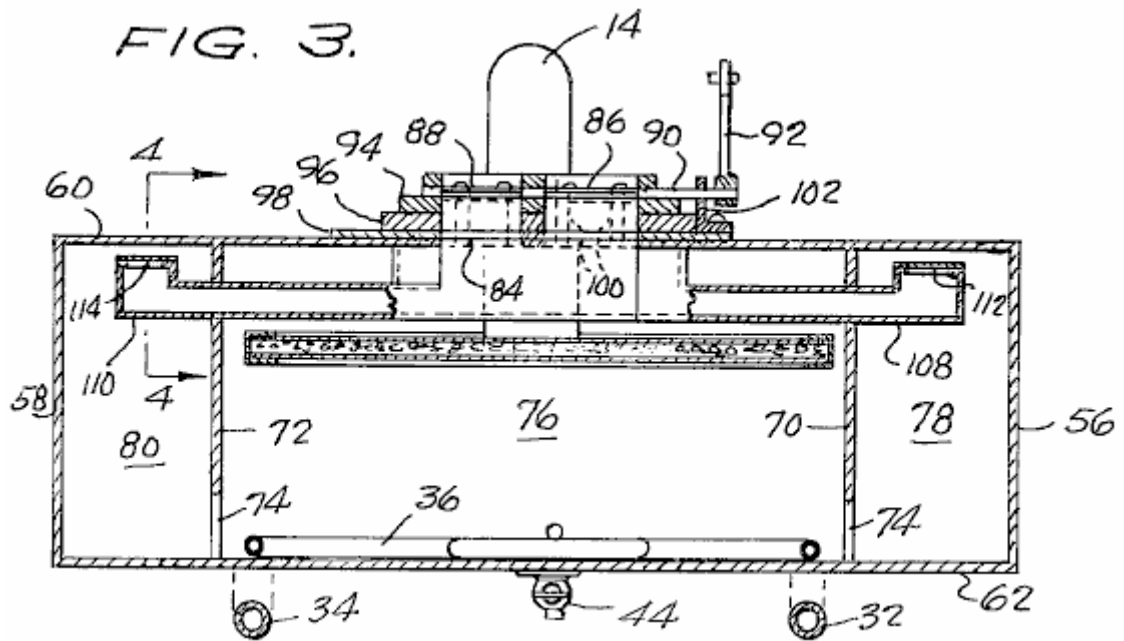

Fig.4 is an enlarged sectional view illustrating in greater detail one component of the vapour tank shown in Fig.3 taken along line 4--4

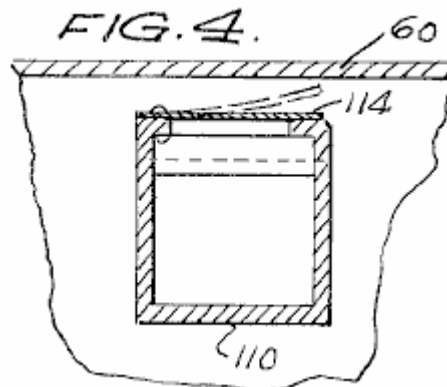

Fig.5 is a perspective, partially sectional view illustrating a filter component of the vapour tank illustrated in Fig.2

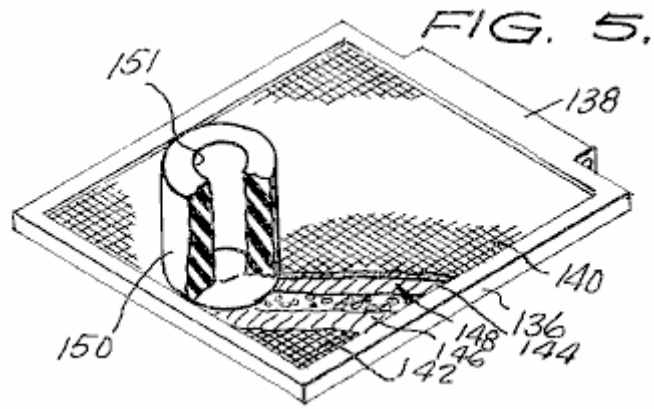

Fig.6 is a cross-sectional view of another component of the preferred embodiment of the present invention illustrated in Fig.1 taken along line 6--6

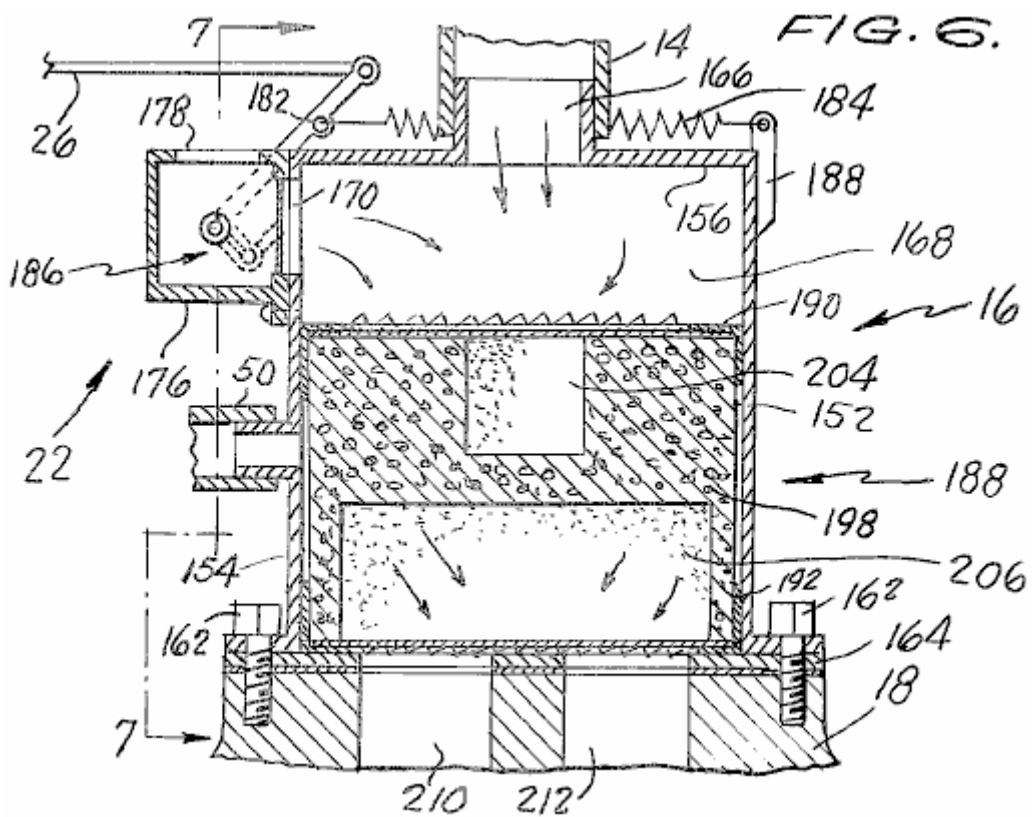

Fig.7 is a partial side, partial sectional view of the vapour equaliser illustrated in Fig.6 taken along line 7--7

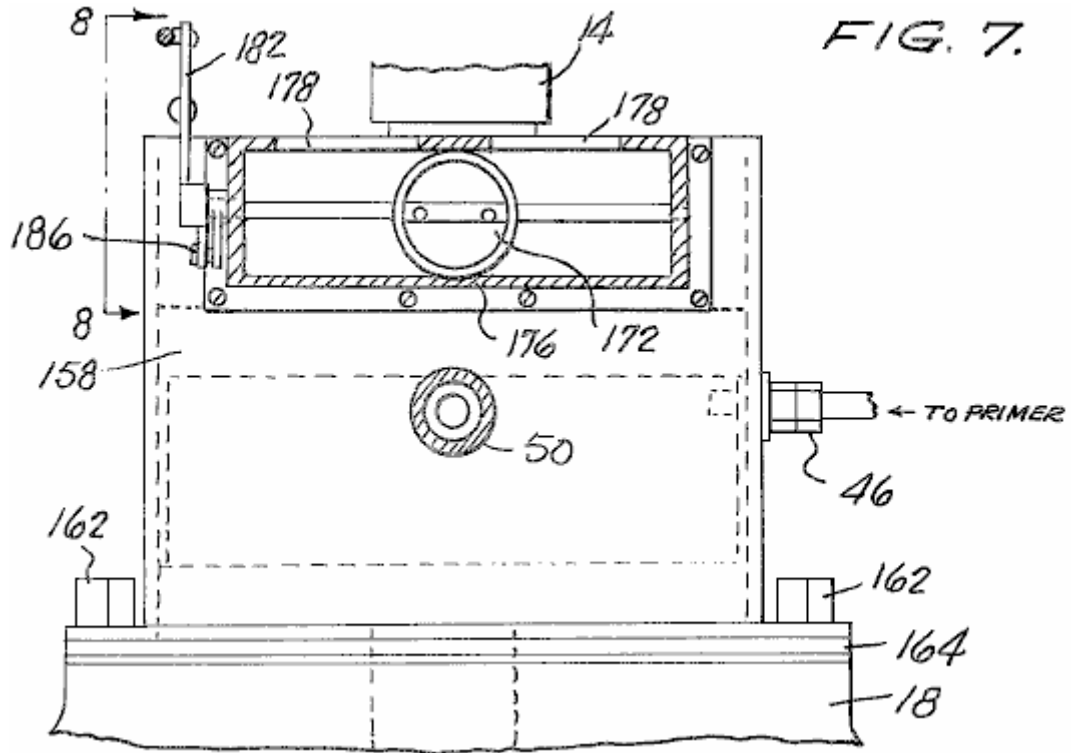

Fig.8 is a side view illustrating the throttle linkage of the vapour equaliser shown in Fig.7 taken along line 8--8

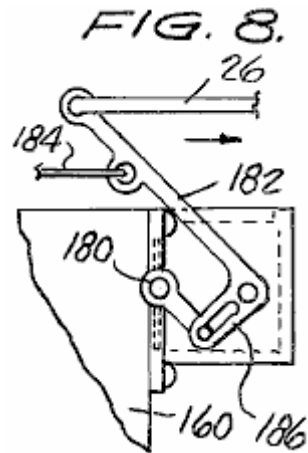

Fig.9 is a longitudinal sectional view of another filter component of the preferred embodiment illustrated in Fig.1

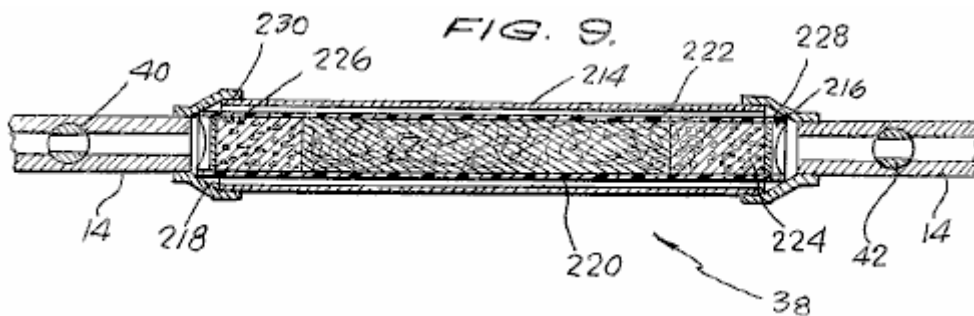

Fig.10 is a view of another component of the present invention

FIG. 10.

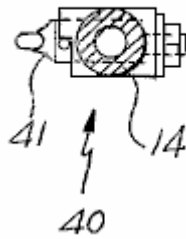
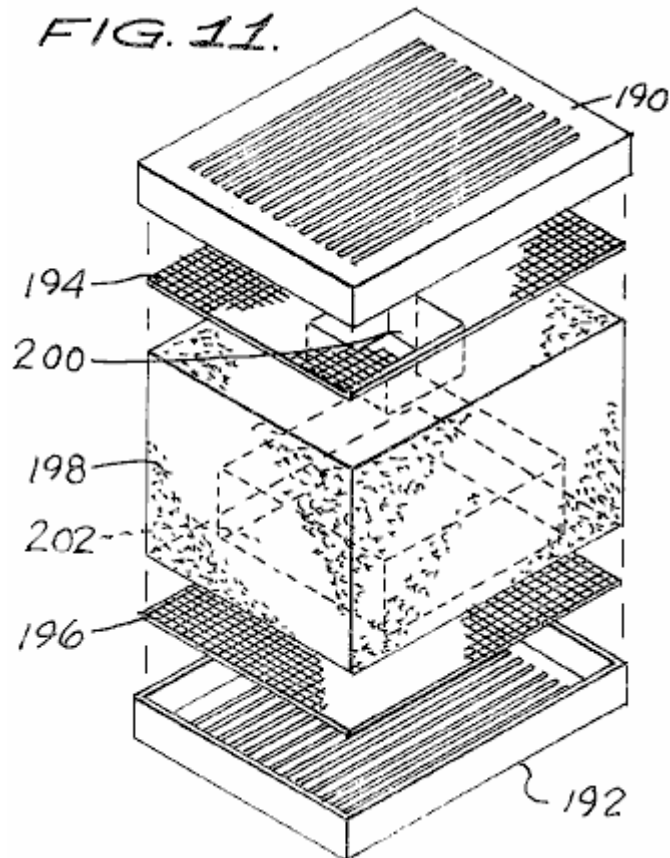

Fig.11 is an exploded, perspective view which illustrates the main components of the filter portion of the vapour equaliser of the present invention.



DETAILED DESCRIPTION OF THE PREFERRED EMBODIMENT

Referring now to the drawings, where parts are numbered the same in each drawing, and more particularly to **Fig.1** which illustrates a preferred embodiment of the present invention as installed in a motor vehicle.

The preferred embodiment includes as its main components a fuel vapour tank **10** in which the fuel vapour is stored and generated for subsequent delivery to the internal combustion engine **20**. On the top of fuel vapour tank **10** is mounted an air inlet control valve **12** whose structure and operation will be described in greater detail below.

The internal combustion engine **20** includes a standard intake manifold **18**. Mounted upon the intake manifold **18** is a vapour equaliser chamber **16**. Connected between the fuel vapour tank **10** and the vapour equaliser chamber **16** is a vapour conduit or hose **14** for conducting the vapours from within tank **10** to the chamber **16**.

Reference numeral **22** indicates generally an air inlet control valve which is mounted on the vapour equaliser chamber **16**. Thus, the system is provided with two separate air inlet control valves **12** and **22** which are respectively coupled via cables **24** and **26** to the throttle control for the motor vehicle which may take the form of a standard accelerator pedal **28**. The air inlet control valves **12** and **22** are synchronised in such a fashion that the opening of the air inlet control valve **22** of the vapour equaliser **16** always precedes and exceeds the opening of the air inlet control valve **12** of the fuel vapour tank **10**, for reasons which will become more clear later.

The cooling system of the vehicle conventionally includes a radiator **30** for storing liquid coolant which is circulated through the engine **20** in the well-known fashion. A pair of hoses **32** and **34** are preferably coupled into the normal heater lines from the engine **20** so as to direct heated liquid coolant from the engine **20** to a warming coil **36**, preferably constructed of copper, which is positioned within vapour tank **10**. I have found that the water circulation system consisting of hoses **32**, **34** and **36** serves three distinct functions. Firstly, it prevents the vapour tank from reaching the cold temperatures to which it would otherwise be subjected as a result of high vacuum pressure and air flow through it. Secondly, the heated coolant serves to enhance vaporisation of the fuel stored within tank **10** by raising its temperature. Thirdly, the liquid coolant, after leaving tank **10** via conduit **34**, has been cooled to the point where engine **20** may then be run at substantially lower operating temperatures to further increase efficiency and prolong the life of the engine.

Included in series with vapour conduit **14** is a filter unit **38** which is designed to retard the flow of fuel vapour from the tank **10** to the vapour equaliser **16**. The precise structure of the filter unit **38** will be described in greater detail below. A thrust adjustment valve **40** is positioned upstream of the filter unit **38** in conduit **14** and acts as a fine adjustment for the idling speed of the vehicle. Positioned on the other side of filter unit **38** in conduit **14** is a safety shut-off valve **42** which comprises a one-way valve. Starting the engine **20** will open the valve **42** to permit the engine vacuum pressure to be transmitted to tank **10**, but, for example, a backfire will close the valve to prevent a possible explosion. The tank **10** may also be provided with a drain **44** positioned at the bottom of the tank.

Positioned on the side of the vapour equaliser chamber **16** is a primer connection **46** which may be controlled by a dash mounted primer control knob **48** connected to tank **10** via conduit **47**. A conduit **50** extends from the oil breather cap opening **52** in a valve cover **54** of the engine **20** to the vapour equaliser **16** to feed the oil blow-by to the engine as a means for eliminating valve clatter. This is believed necessary due to the extreme lean mixture of fuel vapour and air fed to the combustion cylinders of the engine **20** in accordance with the present invention.

Referring now to **Fig.2** and **Fig.3**, the fuel vapour tank **10** of the present invention is illustrated in greater detail in orthogonal sectional views and is seen to include a pair of side walls **56** and **58** which are preferably comprised of heavy duty steel plate (e.g. 1/2" thick) in order to withstand the high vacuum pressures developed inside it. Tank **10** further comprises top wall **60** and bottom wall **62**, and front and rear walls **64** and **66**, respectively.

In the front wall **64** of tank **10** is positioned a coupling **68** for mating the heater hose **32** with the internal copper conduit **36**. Tank **10** is also provided with a pair of vertically oriented planar support plates **70** and **72** which are positioned somewhat inside the side walls **56** and **58** and are substantially parallel to them. Support plates **70** and **72** lend structural integrity to the tank **10** and are also provided with a plurality of openings **74** (**Fig.2**) at the bottom of them to permit fluid communication through it. The bottom of tank **10** is generally filled with from one to five gallons of fuel, and the walls of tank **10** along with plates **70** and **72** define three tank chambers **76**, **78** and **80** which are, by virtue of openings **74**, in fluid communication with one another.

In the top wall **60** of tank **10** is formed an opening **82** for placing one end of vapour conduit **14** in fluid communication with the interior chamber **76** of tank **10**. A second opening **84** is positioned in the top wall **60** of tank **10** over which the air inlet control valve **12** is positioned. The valve assembly **12** comprises a pair of conventional butterfly valves **86** and **88** which are coupled via a control rod **90** to a control arm **92**. Control arm **92** is, in turn, pivoted under the control of a cable **24** and is movable between a solid line position indicated in **Fig.2** by reference numeral **92** and a dotted line position indicated in **Fig.2** by reference numeral **92'**.

Rod **90** and valves **86** and **88** are journaled in a housing **94** having a base plate **96** which is mounted on a cover **98**. As seen in **Fig.1**, the base plate **96** includes several small air intake ports or apertures **100** formed on both sides of the butterfly valves **86** and **88**, which are utilised for a purpose to become more clear later on.

Rod **90** is also journaled in a flange **102** which is mounted to cover **98**, while a return spring **104** for control arm **92** is journaled to cover **98** via flange **106**.

Extending through the baffle and support plates **70** and **72** from the side chambers **78** and **80** of tank **10** to be in fluid communication with apertures **100** are a pair of air conduits **108** and **110** each having a reed valve **112** and **114** positioned at the ends, for controlling air and vapour flow through it. The reed valves **112** and **114** co-operate with the small apertures **100** formed in the base plate **96** to provide the proper amount of air into the tank **10** while the engine is idling and the butterfly valves **86** and **88** are closed.

Mounted to the front wall **64** of tank **10** is a pivot support member **132** for pivotally receiving a filter element which is indicated generally by reference numeral **134** and is illustrated in a perspective, partially cut away view in **Fig.5**. The unique, pivotable filter element **134** comprises a frame member **136** having a pin-receiving stub **138** extending along one side member of it. The actual filter material contained within the frame **136** comprises a layer of carbon particles **148** which is sandwiched between a pair of layers of sponge-like filter material which

may, for example, be made of neoprene. The neoprene layers **144** and **146** and carbon particles **148** are maintained in place by top and bottom screens **140** and **142** which extend within, and are secured by, frame member **136**. A thick-walled rubber hose **150** having a central annulus **151** is secured to the top of screen **140** so as to mate with opening **82** of top wall **60** (see **Fig.2**) when the filter assembly **134** is in its solid line operative position illustrated in **Fig.2**. In the latter position, it may be appreciated that the vapour conduit **14** draws vapour fumes directly from the filter element **134**, rather than from the interior portion **76** of tank **10**. In contradistinction, when the filter element **134** is in its alternate operative position, indicated by dotted lines in **Fig.2**, the vapour conduit **14** draws fumes mainly from the interior portions **76**, **78** and **80** of tank **10**.

Fig.4 is an enlarged view of one of the reed valve assemblies **114** which illustrates the manner in which the valve opens and closes in response to the particular vacuum pressure created within the tank **10**. Valves **112** and **114** are designed to admit just enough air to the tank **10** from the apertures **100** at engine idle to prevent the engine from stalling.

Referring now to **Fig.6**, **Fig.7** and **Fig.8**, the vapour equaliser chamber **16** of the present invention is seen to include front and rear walls **152** and **154**, respectively, a top wall **156**, a side wall **158**, and another side wall **160**. The vapour equaliser chamber **16** is secured to the manifold **18** as by a plurality of bolts **162** under which may be positioned a conventional gasket **164**.

In the top wall **156** of the vapour equaliser **16** is formed an opening **166** for communicating the outlet end of vapour conduit **14** with a mixing and equalising chamber **168**. Adjacent to the mixing and equalising chamber **168** in wall **154** is formed another opening **170** which communicates with the outside air via opening **178** formed in the upper portion of housing **176**. The amount of air admitted through openings **178** and **170** is controlled by a conventional butterfly valve **172**. Butterfly valve **172** is rotated by a control rod **180** which, in turn, is coupled to a control arm **182**. Cable **26** is connected to the end of control arm **182** furthest from the centreline and acts against the return bias of spring **184**, the latter of which is journaled to side plate **152** of vapour equaliser **16** via an upstanding flange **188**. Reference numeral **186** indicates generally a butterfly valve operating linkage, as illustrated more clearly in **Fig.8**, and which is of conventional design as may be appreciated by a person skilled in the art.

Positioned below mixing and equalising chamber **168** is a filter unit which is indicated generally by reference numeral **188**. The filter unit **188**, which is illustrated in an exploded view in **Fig.11**, comprises a top plastic fluted cover **190** and a bottom plastic fluted cover **192**. Positioned adjacent to the top and bottom covers **190** and **192** is a pair of screen mesh elements **194** and **196**, respectively. Positioned between the screen mesh elements **194** and **196** is a support member **198** which is preferably formed of a sponge-like filter material, such as, for example, neoprene. The support member **199** has formed on its upper and lower surfaces, a pair of receptacles **200** and **202**, whose diameters are sized similarly to the opening **166** in top plate **156** and the openings formed in the intake manifold **18** which are respectively indicated by reference numerals **210** and **212** in **Fig.6**.

Positioned in receptacles **200** and **202** are carbon particles **204** and **206**, respectively, for vapour retardation and control purposes.

Referring now to **Fig.9**, the filter unit **38** mounted in vapour conduit **14** is illustrated in a longitudinal sectional view and is seen to comprise an outer flexible cylindrical hose **214** which is adapted to connect with hose **14** at both ends by a pair of adapter elements **216** and **218**. Contained within the outer flexible hose **214** is a cylindrical container **220**, preferably of plastic, which houses, in its centre, a mixture of carbon and neoprene filter fibres **222**. At both ends of the mixture **222** are deposited carbon particles **224** and **226**, while the entire filtering unit is held within the container **220** by end screens **228** and **230** which permit passage of vapours through it while holding the carbon particles **224** and **226** in place.

Fig.10 illustrates one form of the thrust adjustment valve **40** which is placed within line **14**. This valve simply controls the amount of fluid which can pass through conduit **14** via a rotating valve member **41**.

In operation, the thrust adjustment valve **40** is initially adjusted to achieve as smooth an idle as possible for the particular motor vehicle in which the system is installed. The emergency shut-off valve **42**, which is closed when the engine is off, generally traps enough vapour between it and the vapour equaliser **16** to start the engine **20**. Initially, the rear intake valves **12** on the tank **10** are fully closed, while the air intake valves **22** on the equaliser **16** are open to admit a charge of air to the vapour equaliser prior to the vapour from the tank, thus forcing the pre-existing vapour in the vapour equaliser into the manifold. The small apertures **100** formed in base plate **96** on tank **10** admit just enough air to actuate the reed valves to permit sufficient vapour and air to be drawn through vapour conduit **14** and equaliser **16** to the engine **20** to provide smooth idling. The front air valves **22** are always set ahead of the rear air valves **12** and the linkages **24** and **26** are coupled to throttle pedal **28** such that the degree of opening of front valves **22** always exceeds the degree of opening of the rear valves **12**.

Upon initial starting of the engine **20**, due to the closed condition of rear valves **12**, a high vacuum pressure is created within tank **10** which causes the filter assembly **134** positioned in tank **10** to rise to its operative position indicated by solid outline in **Fig.2**. In this manner, a relatively small amount of vapour will be drawn directly from filter **134** through vapour conduit **14** to the engine to permit the latter to run on an extremely lean mixture.

Upon initial acceleration, the front air intake valve **22** will open further, while the rear butterfly assembly **12** will begin to open. The latter action will reduce the vacuum pressure within tank **10** whereby the filter assembly **134** will be lowered to its alternate operating position illustrated in dotted outline in **Fig.2**. In this position, the lower end of the filter assembly **134** may actually rest in the liquid fuel contained within the tank **10**. Accordingly, upon acceleration, the filter assembly **134** is moved out of direct fluid communication with the opening **82** such that the vapour conduit **14** then draws fuel vapour and air from the entire tank **10** to provide a richer combustion mixture to the engine, which is necessary during acceleration.

When the motor vehicle attains a steady speed, and the operator eases off the accelerator pedal **28**, the rear butterfly valve assembly **12** closes, but the front air intake **22** remains open to a certain degree. The closing of the rear air intake **12** increases the vacuum pressure within tank **10** to the point where the filter assembly **134** is drawn up to its initial operating position. As illustrated, in this position, the opening **82** is in substantial alignment with the aperture **151** of hose **150** to place the filter unit **134** in direct fluid communication with the vapour conduit **14**, thereby lessening the amount of vapour and air mixture fed to the engine. Any vapour fed through conduit **14** while the filter **134** is at this position is believed to be drawn directly off the filter unit itself.

I have been able to obtain extremely high mpg figures with the system of the present invention installed on a V-8 engine of a conventional 1971 American-made car. In fact, mileage rates in excess of one hundred miles per US gallon have been achieved with the present invention. The present invention eliminates the need for conventional fuel pumps, carburetors, and fuel tanks, thereby more than offsetting whatever the components of the present invention might otherwise add to the cost of a car. The system may be constructed with readily available components and technology, and may be supplied in kit form as well as original equipment.

Obviously, numerous modifications and variations of the present invention are possible in light of the above teachings. For example, although described in connection with the operation of a motor vehicle, the present invention may be universally applied to any four-stroke engine for which its operation depends upon the internal combustion of fossil fuels. Therefore, it is to be understood that within the scope of the appended claims the invention may be practiced otherwise than as specifically described here.

CLAIMS

1. A fuel vapour system for an internal combustion engine having an intake manifold, which comprises:
 - (a) A tank for containing fuel vapour;
 - (b) A vapour equaliser mounted on and in fluid communication with the intake manifold of the engine;
 - (c) A vapour conduit connecting the tank to the vapour equaliser for delivering fuel vapour from the former to the latter;
 - (d) A vapour equaliser having a valve connected to it for controlling the admission of air to the vapour equaliser;
 - (e) A tank having a second valve connected to it for controlling the admission of air to the tank;
 - (f) A throttle for controlling the first and second valves so that the opening of the first valve precedes and exceeds the opening of the second valve.
2. The fuel vapour system as set forth in claim 1, further comprising a filter positioned in the vapour conduit for retarding the flow of fuel vapour from the tank to the vapour equaliser.
3. The fuel vapour system as set forth in claim 2, where the filter comprises carbon particles.
4. The fuel vapour system as set forth in claim 2, where the filter comprises carbon particles and neoprene fibres.
5. The fuel vapour system as set forth in claim 2, where the filter comprises a substantially tubular housing positioned in series in the vapour conduit, the housing containing a central portion comprising a mixture of carbon and neoprene and end portions comprising carbon positioned on each side of the central portion.
6. The fuel vapour system as set forth in claim 1, further comprising a filter positioned in the vapour equaliser, for retarding the flow of the fuel vapour to the engine intake manifold.
7. The fuel vapour system as set forth in claim 6, where the filter is positioned downstream of the first valve.

8. The fuel vapour system as set forth in claim 7, where the filter comprises carbon particles.
9. The fuel vapour system as set forth in claim 8, where the filter further comprises a porous support member having first and second recessed portions for containing the carbon particles, the first recessed portion being positioned opposite a vapour inlet port in the vapour equaliser to which the vapour conduit is connected, the second recessed portion being positioned opposite the intake manifold of the engine.
10. The fuel vapour system as set forth in claim 9, where the porous support member is comprised of neoprene.
11. The fuel vapour system as set forth in claim 1, with a further filter positioned in the tank for controlling the flow of fuel vapour into the vapour conduit in proportion to the degree of vacuum in the tank.
12. The fuel vapour system as set forth in claim 11, where the filter incorporates a method for reducing the amount of fuel vapour delivered to the vapour conduit when the engine is idling and when the engine has attained a steady speed.
13. The fuel vapour system as set forth in claim 12, where the throttle acts to close the second valve when the engine is idling and when the engine has attained a steady speed to thereby increase the vacuum pressure in the tank.
14. The fuel vapour system as set forth in claim 13, where the filter comprises a frame pivotally mounted within the tank and movable between first and second operating positions, the first operating position corresponding to an open condition of the second valve, said second operating position corresponding to a closed condition of the second valve.
15. The fuel vapour system as set forth in claim 14, where the tank includes a vapour outlet port to which one end of the vapour conduit is connected, and where the second operating position of the frame places the filter in direct fluid communication with the vapour outlet port.
16. The fuel vapour system as set forth in claim 15, where the filter includes carbon particles.
17. The fuel vapour system as set forth in claim 16, where the filter includes neoprene filter material.
18. The fuel vapour system as set forth in claim 17, where the filter comprises a layer of carbon particles sandwiched between two layers of neoprene filter material, and a screen for supporting them within the pivotable frame.
19. The fuel vapour system as set forth in claim 18, further comprising a mechanism positioned on the filter for placing the filter in direct fluid communication with the vapour outlet port when the frame is in the second operating position.
20. A fuel vapour system for an internal combustion engine having an intake manifold, which comprises:
 - (a) A tank for containing fuel vapour;
 - (b) A vapour equaliser mounted on, and in fluid communication with, the intake manifold of the engine;
 - (c) A vapour conduit connecting the tank to the vapour equaliser for delivering fuel vapour from the former to the latter;
 - (d) A vapour equaliser having a first valve connected to it for controlling the admission of air to the vapour equaliser;
 - (e) A tank having a second valve connected to it for controlling the admission of air to the tank;
 - (f) A filter positioned in the vapour conduit for retarding the flow of the fuel vapour from the tank to the vapour equaliser means.
21. The fuel vapour system as set forth in claim 20, where the filter comprises a substantially tubular housing positioned in series in the vapour conduit, the housing containing a central portion comprising a mixture of carbon and neoprene and end portions comprising carbon positioned on each side of the central portion.
22. A fuel vapour system for an internal combustion engine having an intake manifold, which comprises:
 - (a) A tank for containing fuel vapour;
 - (b) A vapour equaliser mounted on and in fluid communication with the intake manifold of the engine;
 - (c) A vapour conduit connecting the tank to the vapour equaliser for delivering fuel vapour from the former to the latter;
 - (d) The vapour equaliser having a first valve connected to it for controlling the admission of air to the vapour equaliser;
 - (e) The tank having a second valve connected to it for controlling the admission of air to the tank;

(f) A filter positioned in the vapour equaliser for retarding the flow of the fuel vapour to the engine intake manifold.

23. The fuel vapour system as set forth in claim 22, where the filter is positioned downstream of the first valve, the filter comprises carbon particles and a porous support member having first and second recessed portions for containing the carbon particles, the first recessed portion being positioned opposite a vapour inlet port in the vapour equaliser to which the vapour conduit is connected, the second recessed portion being positioned opposite the intake manifold of the engine, and where the porous support member is comprised of neoprene.

The Permanent Magnet Motor of Stephen Kundel

US Patent 7,151,332

19th December 2006

Inventor: Stephen Kundel

MOTOR HAVING RECIPROCATING AND ROTATING PERMANENT MAGNETS

This patent describes a motor powered mainly by permanent magnets. This system uses a rocking frame to position the moving magnets so that they provide a continuous turning force on the output shaft.

ABSTRACT

A motor which has a rotor supported for rotation about an axis, and at least one pair of rotor magnets spaced angularly about the axis and supported on the rotor, at least one reciprocating magnet, and an actuator for moving the reciprocating magnet cyclically toward and away from the pair of rotor magnets, and consequently rotating the rotor magnets relative to the reciprocating magnet.

US Patent References:

0561144	June, 1896	Trudeau
1724446	August, 1929	Worthington
2790095	April, 1957	Peek et al.
3469130	September, 1969	Jines et al.
3703653	November, 1972	Tracy
3811058	May, 1974	Kiniski
3879622	April, 1975	Ecklin
3890548	June, 1975	Gray
3899703	August, 1975	Kinnison
3967146	June, 1976	Howard
3992132	November, 1976	Putt
4011477	March, 1977	Scholin
4151431	April, 1979	Johnson
4179633	December, 1979	Kelly
4196365	April, 1980	Presley
4267647	May, 1981	Anderson et al.
4629921	December, 1986	Gavaletz
4751486	June, 1988	Minato
5402021	March, 1995	Johnson
5594289	January, 1997	Minato
5634390	June, 1997	Takeuchi et al.
5751083	May, 1998	Tamura et al.
5925958	July, 1999	Pirc
6169343	January, 2001	Rich, Sr.
6343419	February, 2002	Litman et al.
6841909	January, 2005	Six
20020167236	November, 2002	Long
20040140722	July, 2004	Long

BACKGROUND OF THE INVENTION

This invention relates to the field of motors. More particularly, it pertains to a motor whose rotor is driven by the mutual attraction and repulsion of permanent magnets located on the rotor and an oscillator.

Various kinds of motors are used to drive a load. For example, hydraulic and pneumatic motors use the flow of pressurised liquid and gas, respectively, to drive a rotor connected to a load. Such motors must be continually supplied with pressurised fluid from a pump driven by energy converted to rotating power by a prime mover, such as an internal combustion engine. The several energy conversion processes, flow losses and pumping losses decrease the operating efficiency of motor systems of this type.

Conventional electric motors employ the force applied to a current carrying conductor placed in a magnetic field. In a d. c. motor the magnetic field is provided either by permanent magnets or by field coils wrapped around clearly defined field poles on a stator. The conductors on which the force is developed are located on a rotor and supplied with electric current. The force induced in the coil is used to apply rotor torque, whose magnitude varies

with the magnitude of the current and strength of the magnetic field. However, flux leakage, air gaps, temperature effects, and the counter-electromotive force reduce the efficiency of the motor.

Permanent dipole magnets have a magnetic north pole, a magnetic south pole, and magnetic fields surrounding each pole. Each magnetic pole attracts a pole of opposite magnetic polarity. Two magnetic poles of the same polarity repel each other. It is desired that a motor be developed such that its rotor is driven by the mutual attraction and repulsion of the poles of permanent magnets.

SUMMARY OF THE INVENTION

A motor according to the present invention includes a rotor supported for rotation about an axis, a first pair of rotor magnets including first and second rotor magnets spaced angularly about the axis and supported on the rotor, a reciprocating magnet, and an actuator for moving the reciprocating magnet cyclically toward and away from the first pair of rotor magnets, and cyclically rotating the first pair of rotor magnets relative to the reciprocating magnet. Preferably the motor includes a second pair of rotor magnets supported on the rotor, spaced axially from the first pair of rotor magnets, the second pair including a third rotor magnet and a fourth rotor magnet spaced angularly about the axis from the third rotor magnet. The reciprocating magnet is located axially between the first and second rotor magnet pairs, and the actuator cyclically moves the reciprocating magnet toward and away from the first and second pairs of rotor magnets.

The magnets are preferably permanent dipole magnets. The poles of the reciprocating magnet are arranged such that they face in opposite lateral directions.

The motor can be started by manually rotating the rotor about its axis. Rotation continues by using the actuator to move the reciprocating magnet toward the first rotor magnet pair and away from the second rotor magnet pair when rotor rotation brings the reference pole of the first rotor magnet closer to the opposite pole of the reciprocating magnet, and the opposite pole of the second rotor magnet closer to the reference pole of the reciprocating magnet. Then the actuator moves the reciprocating magnet toward the second rotor magnet pair and away from the first rotor magnet pair when rotor rotation brings the reference pole of the third rotor magnet closer to the opposite pole of the reciprocating magnet, and the opposite pole of the fourth rotor magnet closer to the reference pole of the reciprocating magnet.

A motor according to this invention requires no power source to energise a field coil because the magnetic fields of the rotor and oscillator are produced by permanent magnets. A nine-volt DC battery has been applied to an actuator switching mechanism to alternate the polarity of a solenoid at the rotor frequency. The solenoid is suspended over a permanent magnet of the actuator mechanism such that rotor rotation and the alternating polarity of a solenoid causes the actuator to oscillate the reciprocating magnet at a frequency and phase relation that is most efficient relative to the rotor rotation.

The motor is lightweight and portable, and requires only a commercially available portable d. c. battery to power an actuator for the oscillator. No motor drive electronics is required. Operation of the motor is practically silent.

Various objects and advantages of this invention will become apparent to those skilled in the art from the following detailed description of the preferred embodiment, when read in light of the accompanying drawings.

BRIEF DESCRIPTION OF THE DRAWINGS

These and other advantages of the present invention will become apparent to those skilled in the art from the following detailed description of a preferred embodiment when considered in the light of the accompanying drawings in which:

Figure 1A

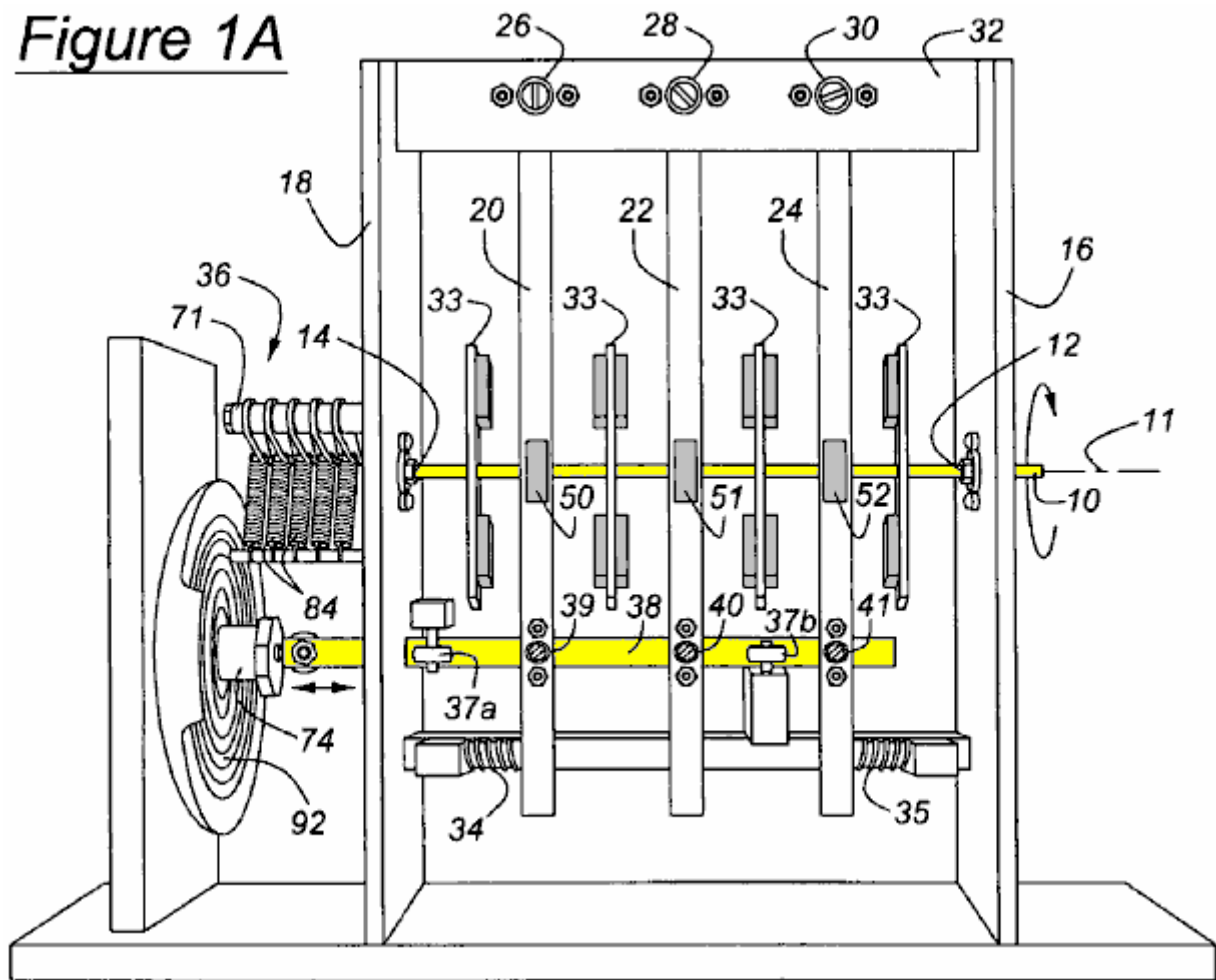

Fig.1A is a side view of a motor according to this invention;

Figure 1B

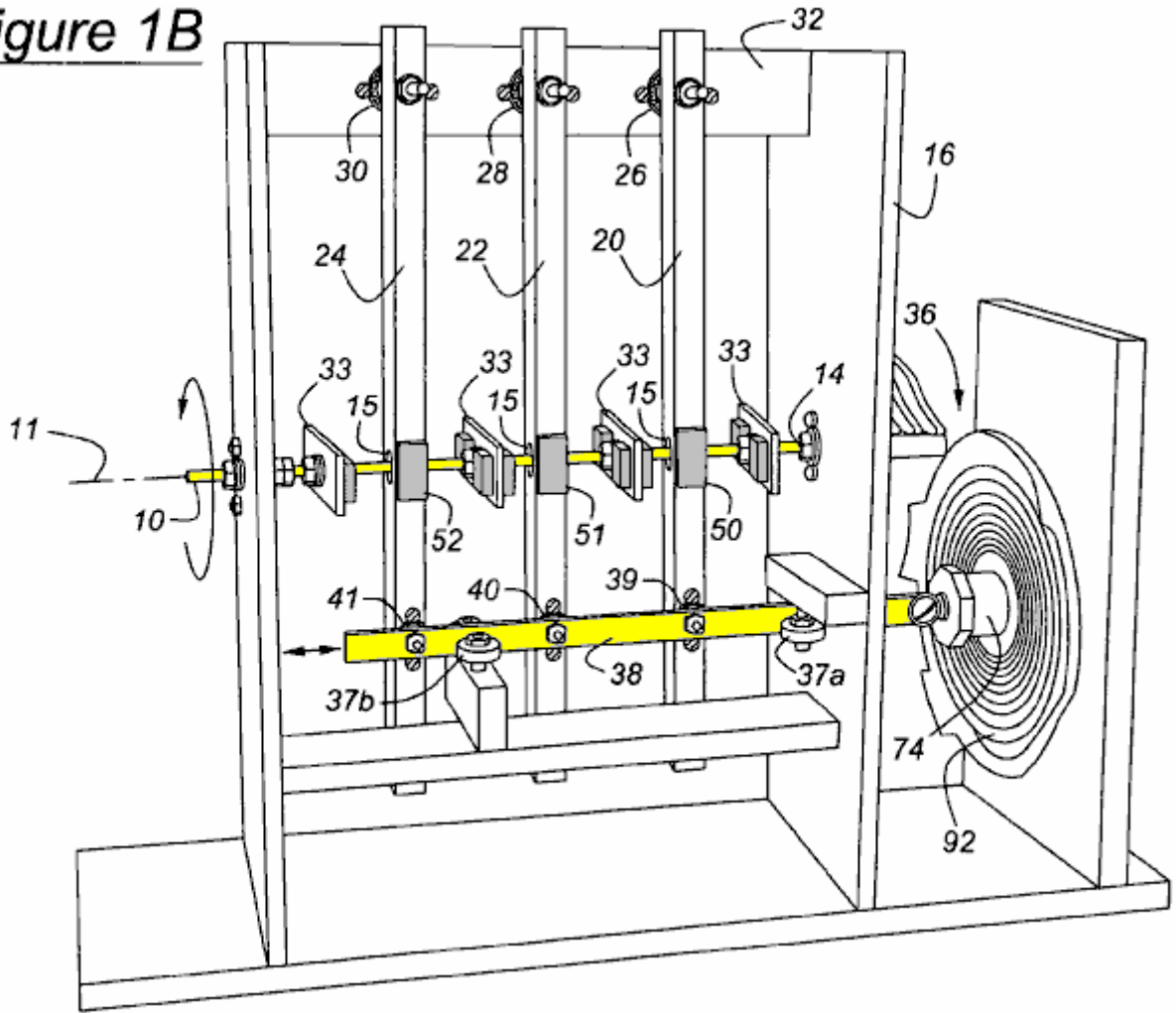

Fig.1B is a perspective view of the motor of **Fig.1A**

Figure 2

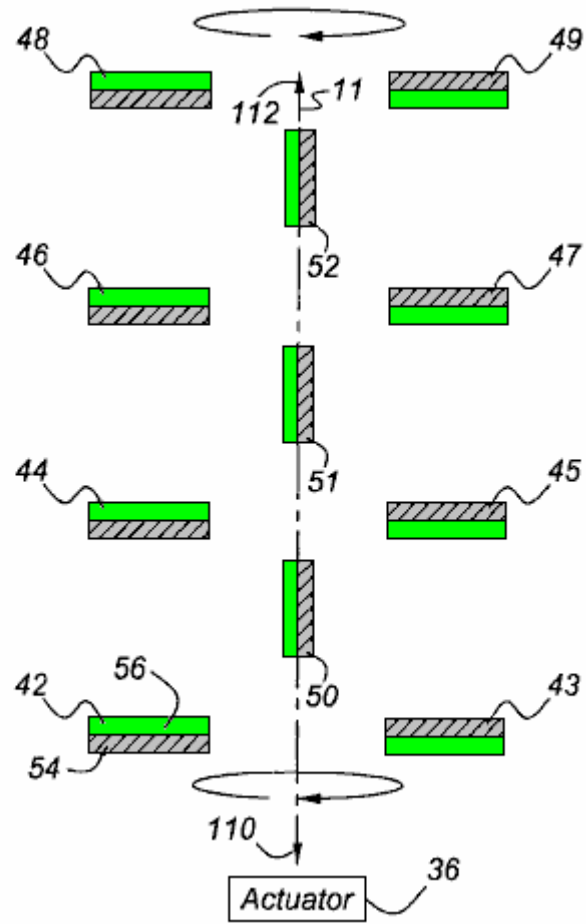

Fig.2 is a top view of the of motor of **Fig.1A** and **Fig.1B** showing the rotor magnets disposed horizontally and the reciprocating magnets located near one end of their range of travel

Figure 3

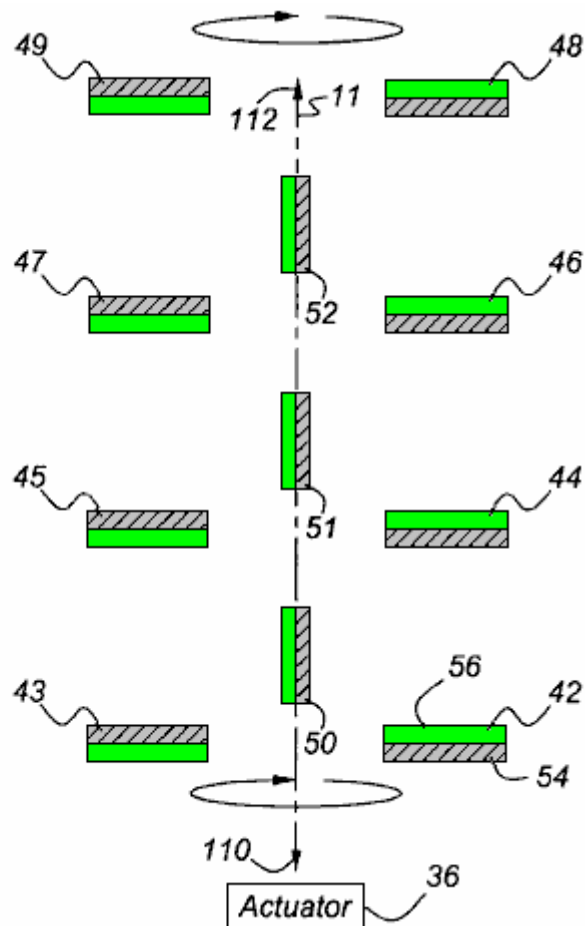

Fig.3 is a top view of the motor of **Fig.2** showing the rotor magnets rotated one-half revolution from the position shown in **Fig.2**, and the reciprocating magnets located near the opposite end of their range of travel

Figure 4

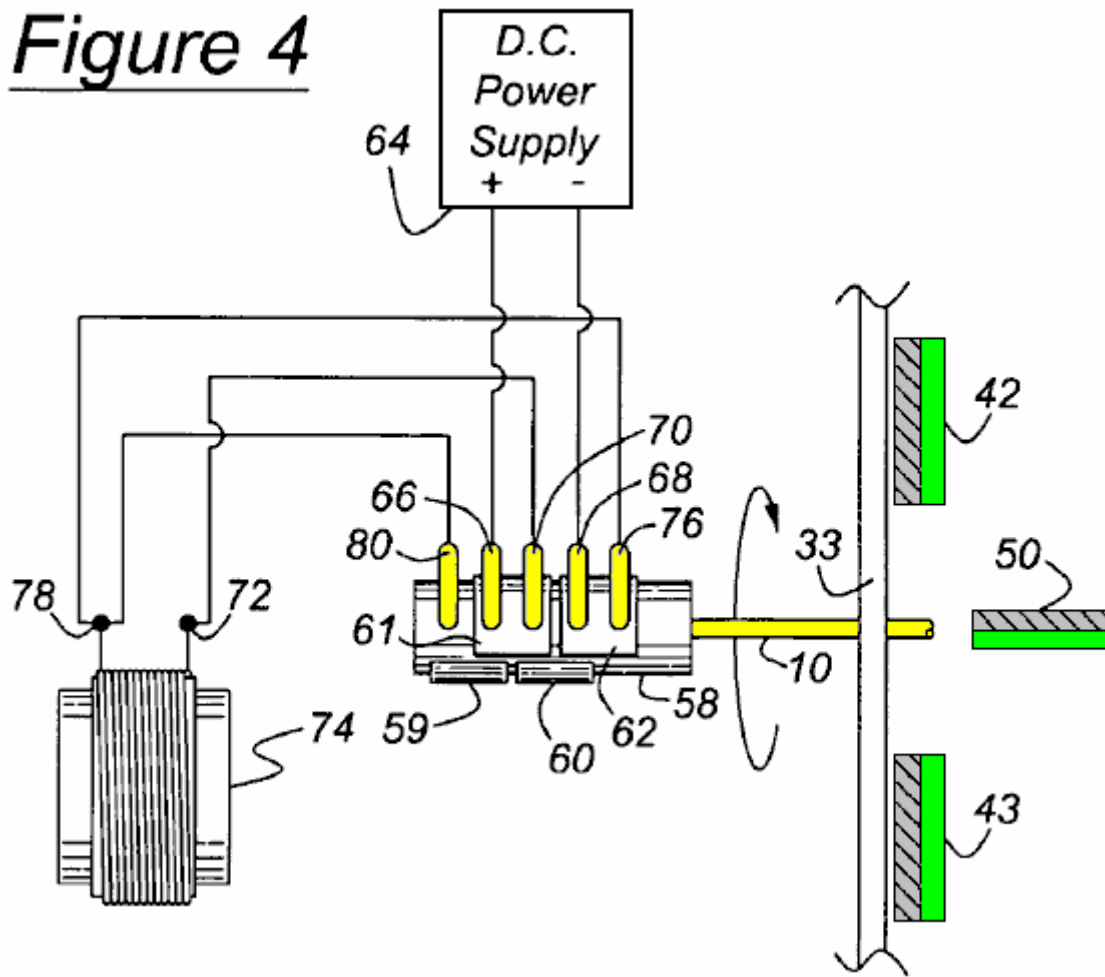

Fig.4 is a schematic diagram of a first state of the actuator switching assembly of the motor of **Fig.1**

Figure 5

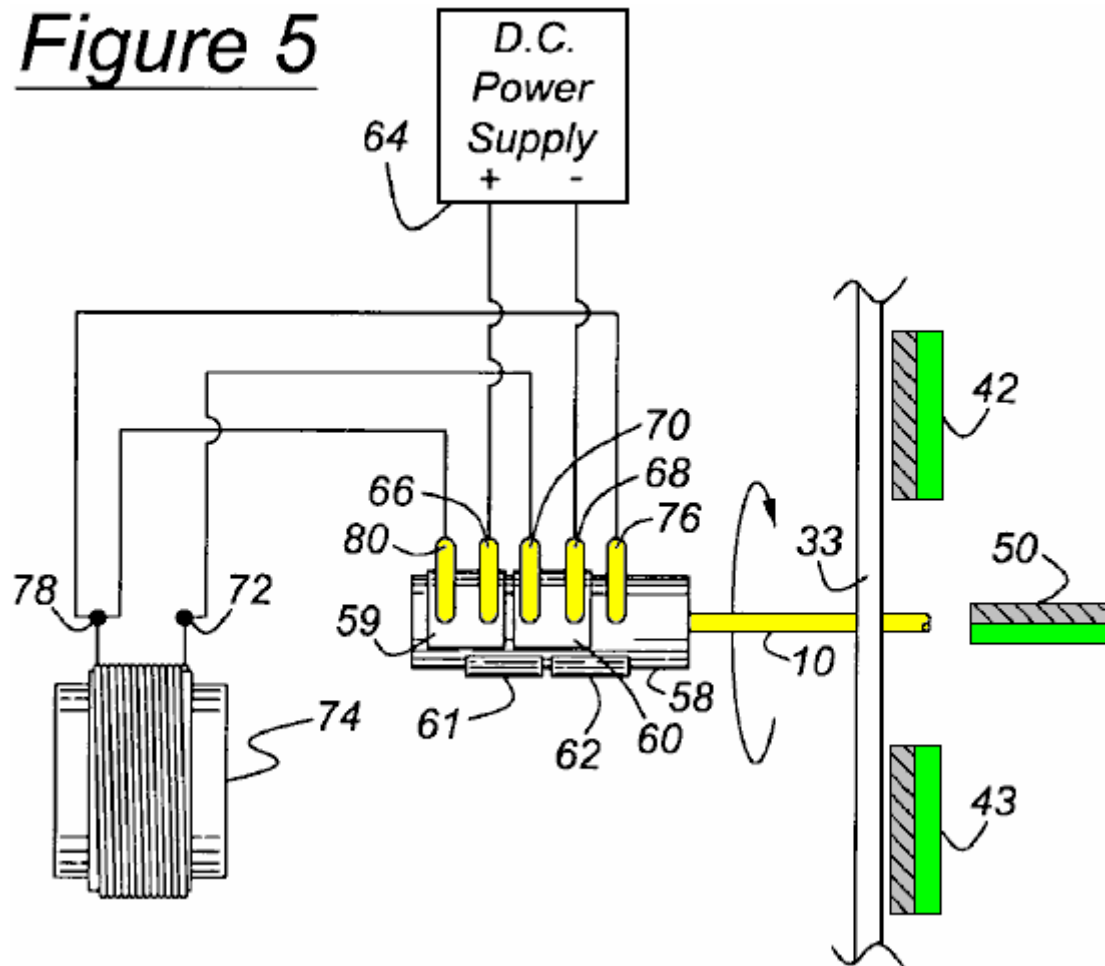

Fig.5 is a schematic diagram of a second state of the actuator switching assembly of the motor of **Fig.1**

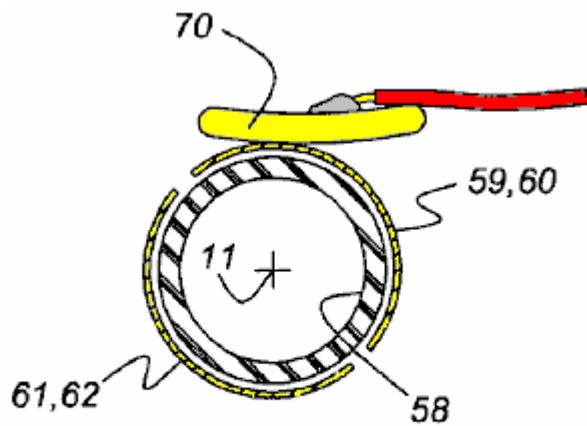

Figure 6

Fig.6 is cross sectional view of a sleeve shaft aligned with the rotor shaft showing a contact finger and bridge contact plates of the switching assembly

Figure 7

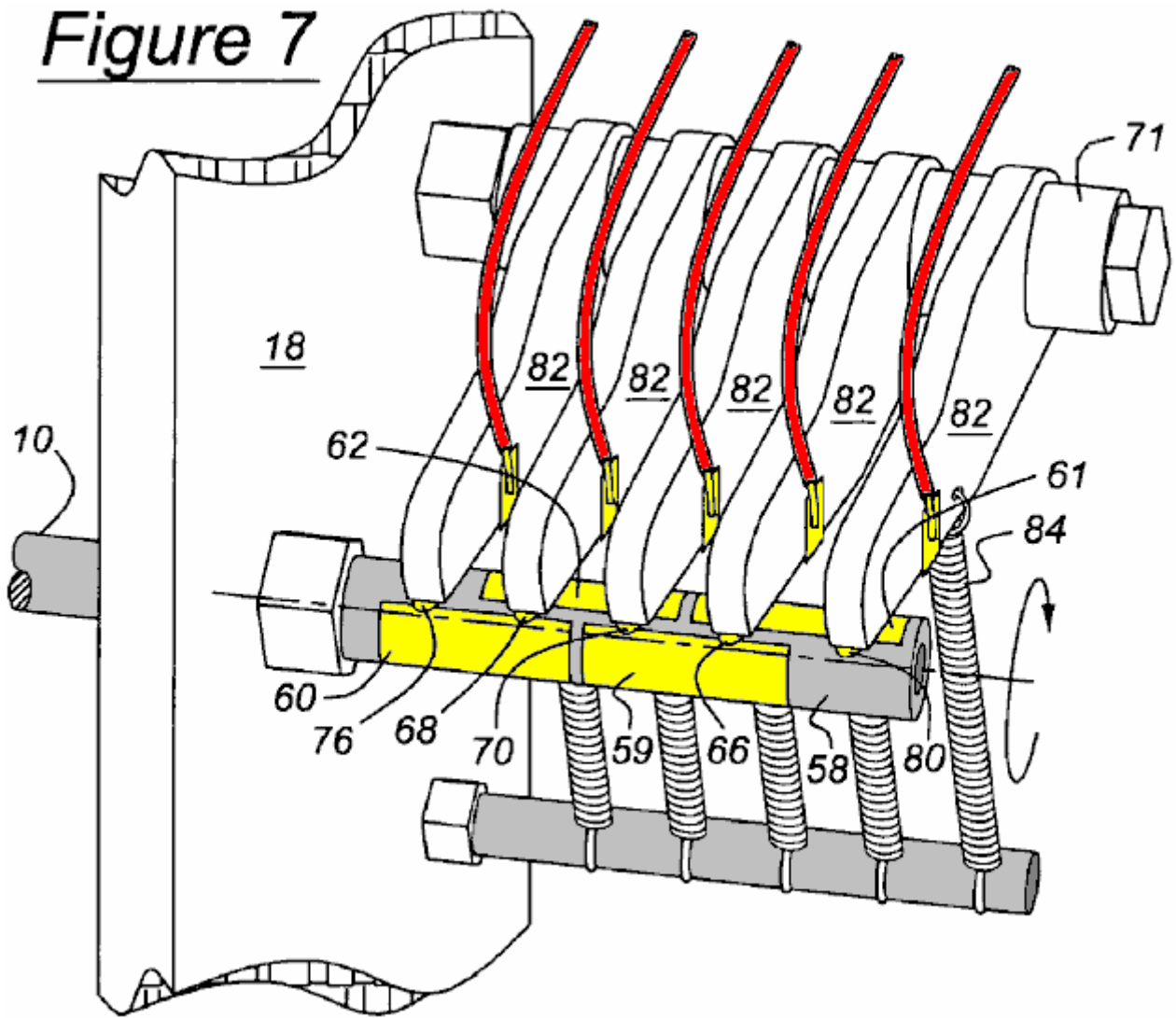

Fig.7 is an isometric view showing the switching contact fingers secured on pivoting arms and seated on the bridge connectors of the switching assembly

Figure 8

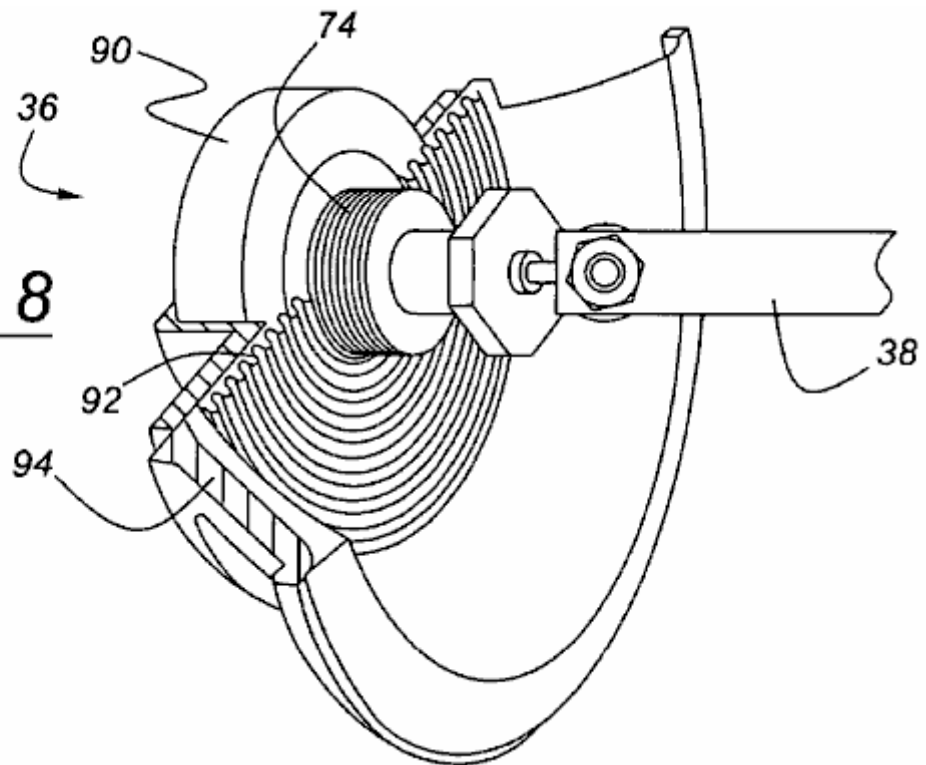

Fig.8 is isometric cross sectional view showing a driver that includes a solenoid and permanent magnet for oscillating the actuator arm in response to rotation of the rotor shaft

Figure 9

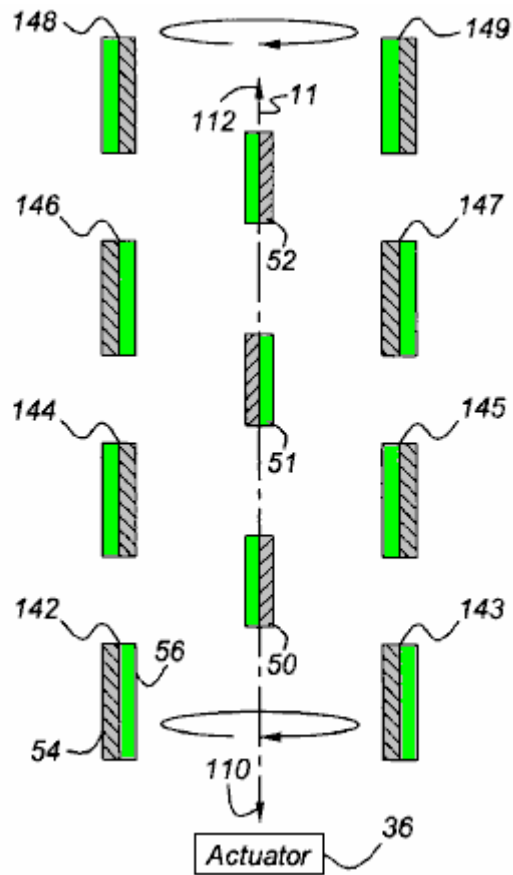

Fig.9 is a top view of an alternate arrangement of the rotor magnets, wherein they are disposed horizontally and rotated ninety degrees from the position shown in **Fig.2**, and the reciprocating magnets are located near an end of their range of displacement

Figure 10

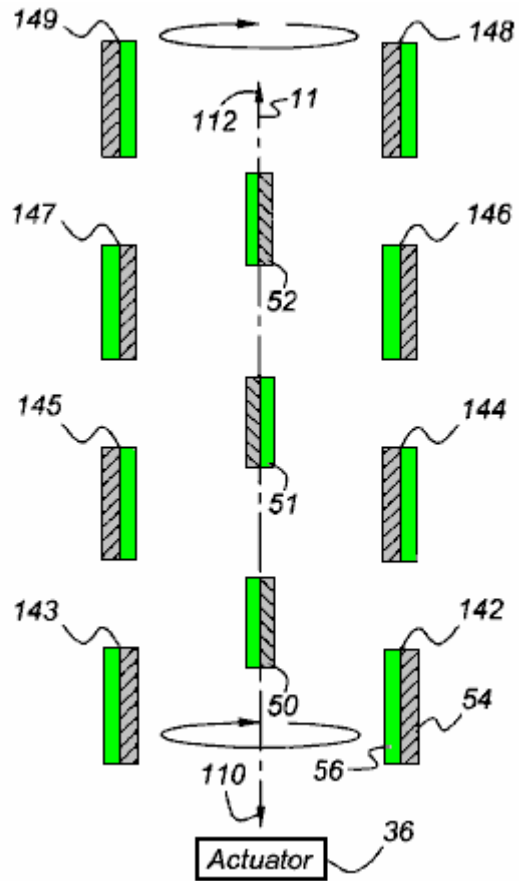

Fig.10 is a top view showing the rotor magnet arrangement of **Fig.9** rotated one-half revolution from the position shown in **Fig.9**, and the reciprocating magnets located near the opposite end of their range of displacement; and

Figure 11

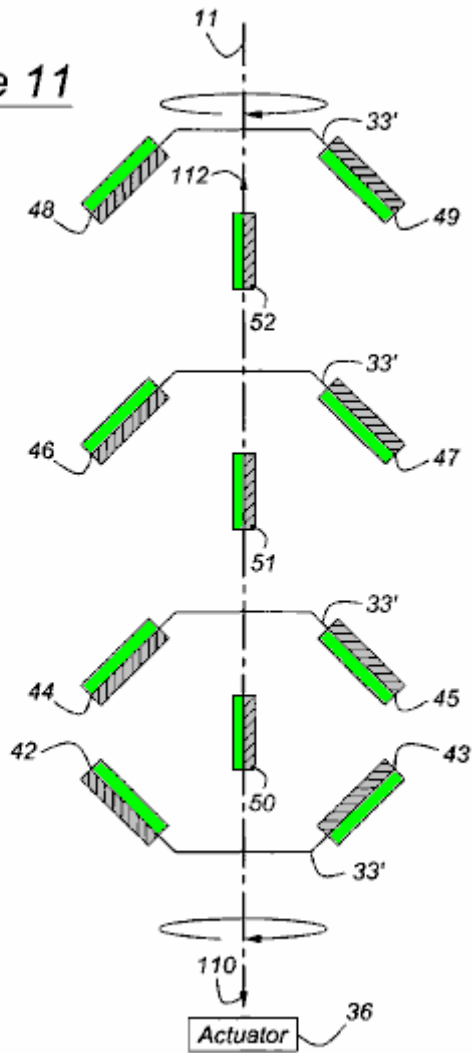

Fig.11 is a top view of the motor showing a third arrangement of the rotor magnets, which are canted with respect to the axis and the reciprocating magnets.

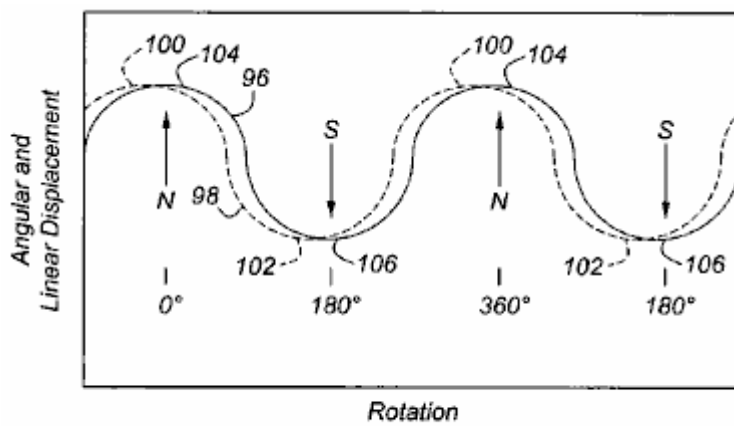

Figure 12

Fig.12 is a graph showing the angular displacement of the rotor shaft 10 and linear displacement of the reciprocating magnets

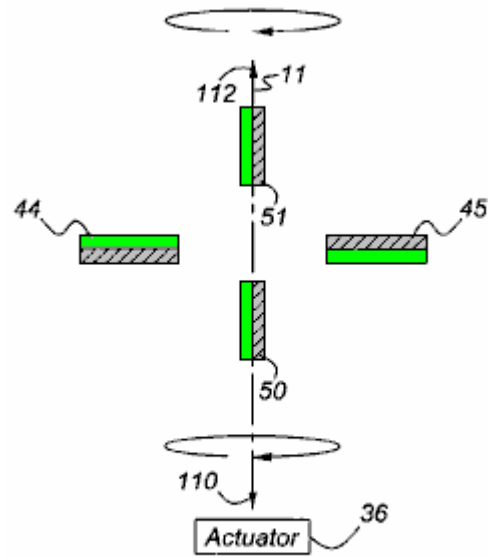

Figure 13

Fig.13 is a top view of a pair of rotor magnets disposed horizontally and reciprocating magnets located near one end of their range of travel

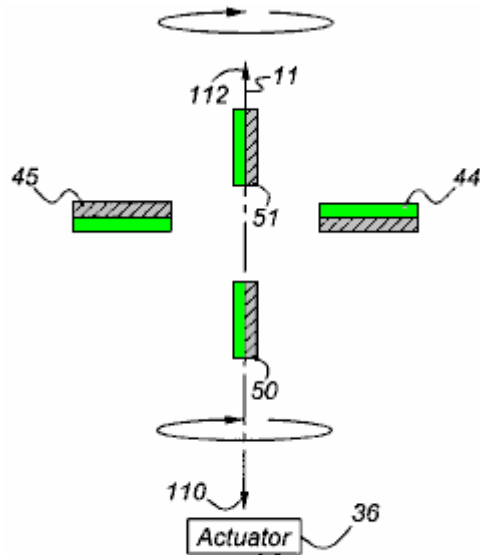

Figure 14

Fig.14 is a top view of the motor of **Fig.13** showing the rotor magnets rotated one-half revolution from the position shown in **Fig.13**, and the reciprocating magnets located near the opposite end of their range of travel; and

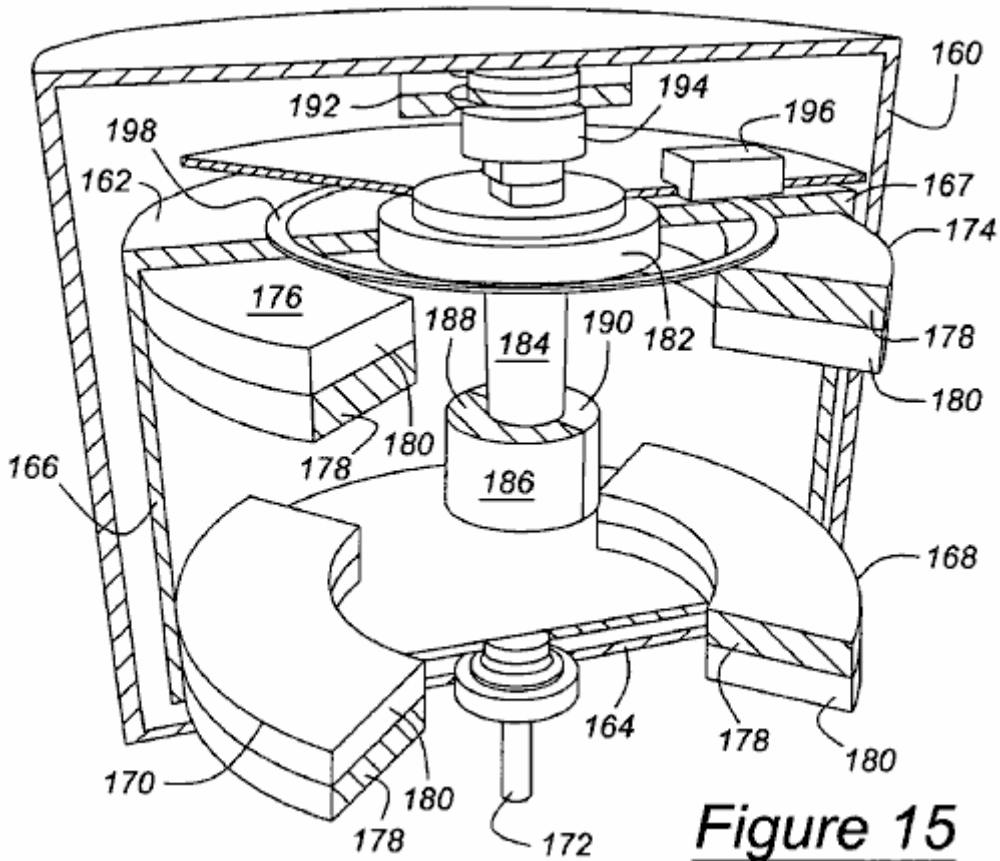
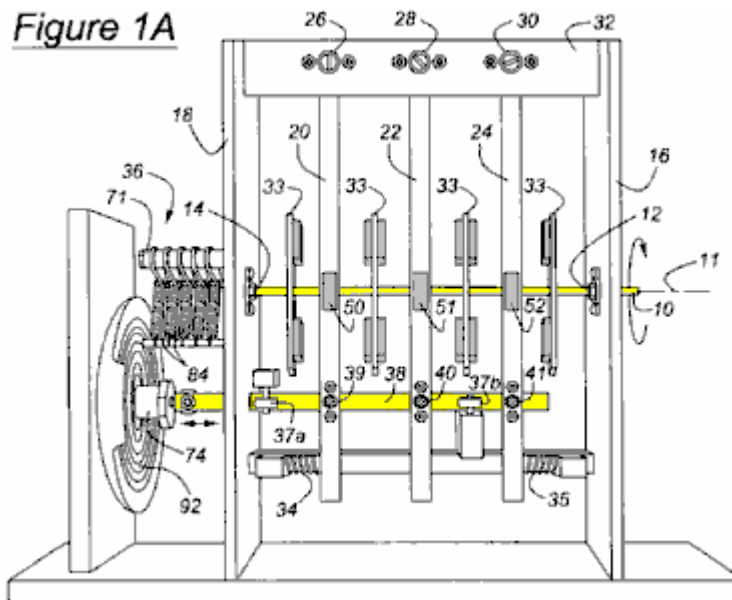

Figure 15

Fig.15 is a perspective cross sectional view of yet another embodiment of the motor according to this invention.

DETAILED DESCRIPTION OF THE PREFERRED EMBODIMENT



A motor according to this invention, illustrated in **Fig.1A** and **Fig.1B** includes a rotor shaft 10 supported for rotation about axis 11 on bearings 12 and 14 located on vertical supports 16 and 18 of a frame. An oscillator mechanism includes oscillator arms 20, 22 and 24 pivotally supported on bearings 26, 28 and 30 respectively, secured to a horizontal support 32, which is secured at each axial end to the vertical supports 16 and 18. The oscillator arms 20, 22 and 24 are formed with through holes 15 aligned with the axis 11 of rotor shaft 10, the holes permitting rotation of the rotor shaft and pivoting oscillation of arms without producing interference between the rotor and the arms.

Extending in opposite diametric directions from the rotor axis **11** and secured to the rotor shaft **10** are four plates **33** , axially spaced mutually along the rotor axis, each plate supporting permanent magnets secured to the plate and rotating with the rotor shaft.

Each pivoting oscillator arm **20**, **22** and **24** of the oscillator mechanism support permanent magnets located between the magnets of the rotor shaft. Helical coiled compression return springs **34** and **35** apply oppositely directed forces to oscillator arms **20** and **24** as they pivot about their respective pivotal supports **26** and **30**, respectively. From the point of view of **Fig.1A** and **Fig.1B**, when spring **34** is compressed by displacement of the oscillator arm, the spring applies a force to the right to oscillator arm **20** which tends to return it to its neutral, starting position. When spring **35** is compressed by displacement of arm **24**, the spring applies a force to the left to arm **24** tending to return it to its neutral, starting position.

The oscillator arms **20**, **22** and **24** oscillate about their supported bearings **26**, **28** and **30** , as they move in response to an actuator **36**, which includes an actuator arm **38**, secured through bearings at **39**, **40** and **41** to the oscillator arms **20**, **22** and **24**, respectively. Actuator **36** causes actuator arm **38** to reciprocate linearly leftwards and rightwards from the position shown in **Fig.1A** and **Fig.1B**. The bearings **39**, **40** and **41**, allow the oscillator arms **20**, **22** and **24** to pivot and the strut to translate without mutual interference. Pairs of guide wheels **37a** and **37b** spaced along actuator arm **38**, each include a wheel located on an opposite side of actuator arm **38** from another wheel of the wheel-pair, for guiding linear movement of the strut and maintaining the oscillator arms **20**, **22** and **24** substantially in a vertical plane as they oscillate. Alternatively, the oscillator arms **20**, **22** and **24** may be replaced by a mechanism that allows the magnets on the oscillator arms to reciprocate linearly with actuator arm **38** instead of pivoting above the rotor shaft **10** at **26**, **28** and **30**.

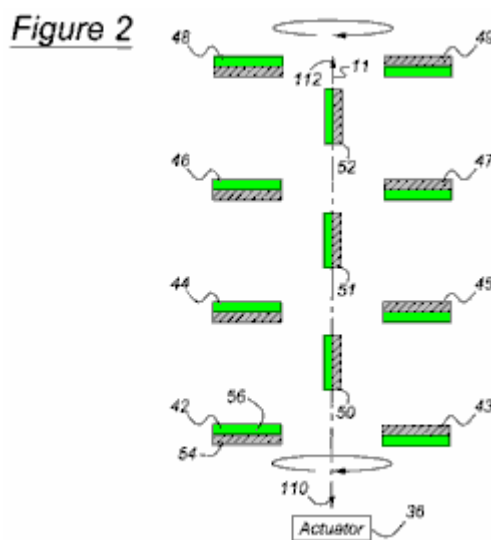

Fig.2 shows a first arrangement of the permanent rotor magnets **42 – 49** that rotate about axis **11** and are secured to the rotor shaft **10**, and the permanent reciprocating magnets **50 – 52** which move along axis **11** and are secured to the oscillating arms **20**, **22** and **24**. Each magnet has a pole of reference polarity and a pole of opposite polarity from that of the reference polarity. For example, rotor magnets **42**, **44**, **46** and **48**, located on one side of axis **11**, each have a north, positive or reference pole **54** facing actuator **36** and a south, negative or opposite pole **56** facing away from the actuator. Similarly, rotation magnets **43**, **45**, **47** and **49**, located diametrically opposite to rotor magnets **42**, **44**, **46** and **48**, each have a south pole facing toward actuator **36** and a north pole facing away from the actuator. The north poles **54** of the reciprocating magnets **50 – 52** face to the right from the point of view seen in **Fig.2** and **Fig.3** and their south poles **56** face towards the left.

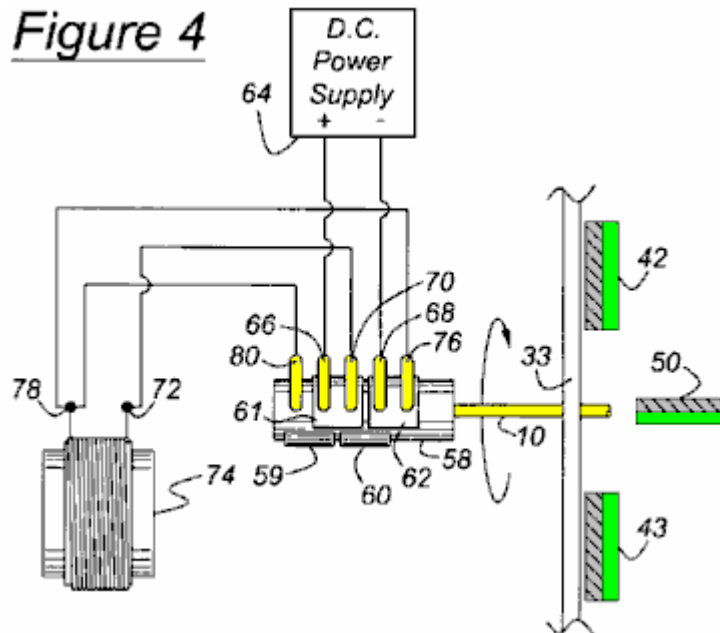

Fig.4 shows a switch assembly located in the region of the left-hand end of rotor shaft **10**. A cylinder, **58**, preferably formed of PVC, is secured to rotor shaft **10**. Cylinder **58** has contact plates **59** and **60**, preferably of brass, located on its outer surface, aligned angularly, and extending approximately 180 degrees about the axis **11**, as shown in **Fig.5**. Cylinder **58** has contact plates **61** and **62**, preferably made of brass, located on its outer surface, aligned angularly, extending approximately 180 degrees about the axis **11**, and offset axially with respect to contact plates **59** and **60**.

A D.C. power supply **64**, has its positive and negative terminals connected electrically through contact fingers **66** and **68**, to contact plates **61** and **62**, respectively. A third contact finger **70**, shown contacting plate **61**, connects terminal **72** of a solenoid **74** electrically to the positive terminal of the power supply **64** through contact finger **66** and contact plate **61**. A fourth contact finger **76**, shown contacting plate **62**, connects terminal **78** of solenoid **74** electrically to the negative terminal of the power supply **64** through contact finger **68** and contact plate **62**. A fifth contact finger **80**, axially aligned with contact plate **59** and offset axially from contact plate **61**, is also connected to terminal **78** of solenoid **74**.

Preferably the D.C. power supply **64** is a nine volt battery, or a D.C. power adaptor, whose input may be a conventional 120 volt, 60 Hz power source. The D.C. power supply and switching mechanism described with reference to **Figs. 4 to 7**, may be replaced by an A.C. power source connected directly across the terminals **72** and **78** of solenoid **74**. As the input current cycles, the polarity of solenoid **74** alternates, the actuator arm **38** moves relative to a toroidal permanent magnet **90** (shown in **Fig.8**), and the reciprocating magnets **50 - 52** reciprocate on the oscillating arms **20, 22** and **24** which are driven by the actuator arm **38**.

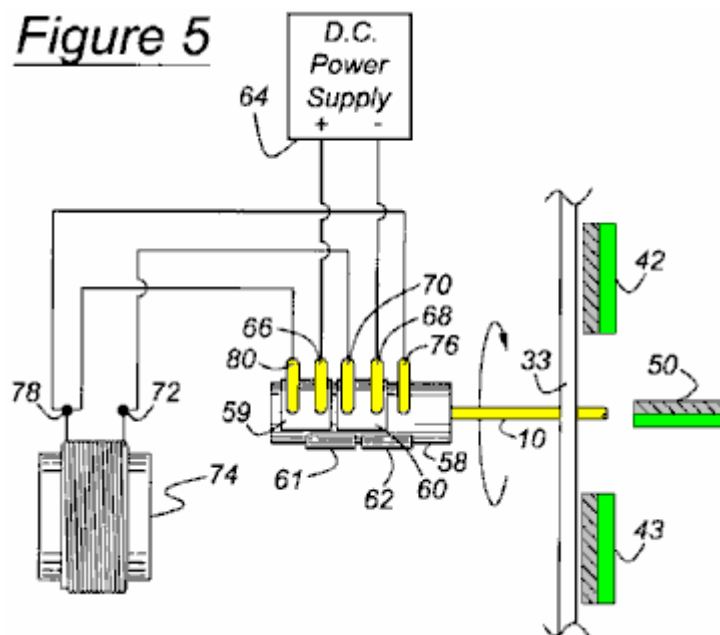

Fig.5 shows the state of the switch assembly when rotor shaft **10** has rotated approximately 180 degrees from the position shown in **Fig.4**. When the switch assembly is in the state shown in **Fig.5**, D.C. power supply **64** has its positive and negative terminals connected electrically by contact fingers **66** and **68** to contact plates **59** and **60**, respectively. Contact finger **70**, shown contacting plate **60**, connects terminal **72** of solenoid **74** electrically to the negative terminal of the power supply **64** through contact finger **68** and contact plate **60**. Contact finger **80**, shown contacting plate **59**, connects terminal **78** of solenoid **74** electrically to the positive terminal through contact finger **66** and contact plate **59**. Contact finger **76**, axially aligned with contact plate **62** and offset axially from contact plate **60**, remains connected to terminal **78** of solenoid **74**. In this way, the polarity of the solenoid **74** changes cyclically as the rotor **10** rotates through each one-half revolution.

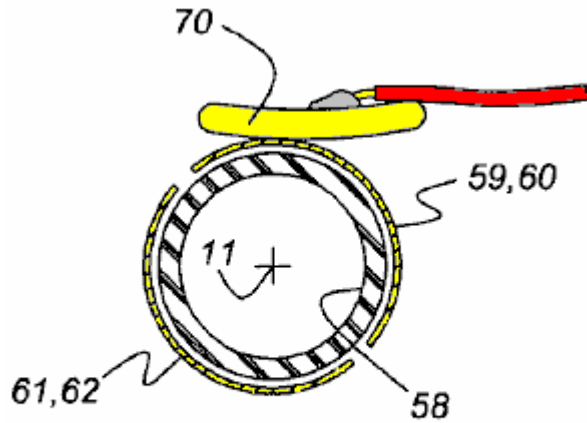
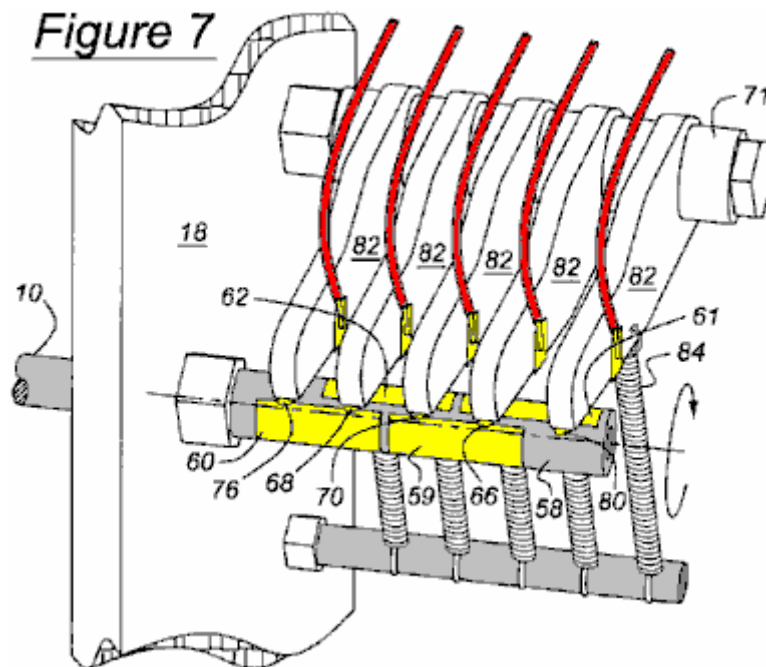

Figure 6

Fig.6 shows in cross-section, the cylinder **58** which is aligned with and driven by the rotor shaft **10**, a contact finger **70**, and the contact plates **59 – 62** of the switching assembly, which rotate with the rotor shaft and cylinder about the axis **11**.



As **Fig.7** illustrates, axially spaced arms **82** are supported on a stub shaft **71**, preferably made of Teflon or another self-lubricating material, to facilitate the pivoting of the arms about the axis of the shaft **71**. Each contact finger **66**, **68**, **70**, **76** and **80** is located at the end of a arm **82**, and tension springs **84**, secured to each arm **82**, urge the contact fingers **66**, **68**, **70**, **76** and **80** continually toward engagement with the contact plates **59 – 62**.

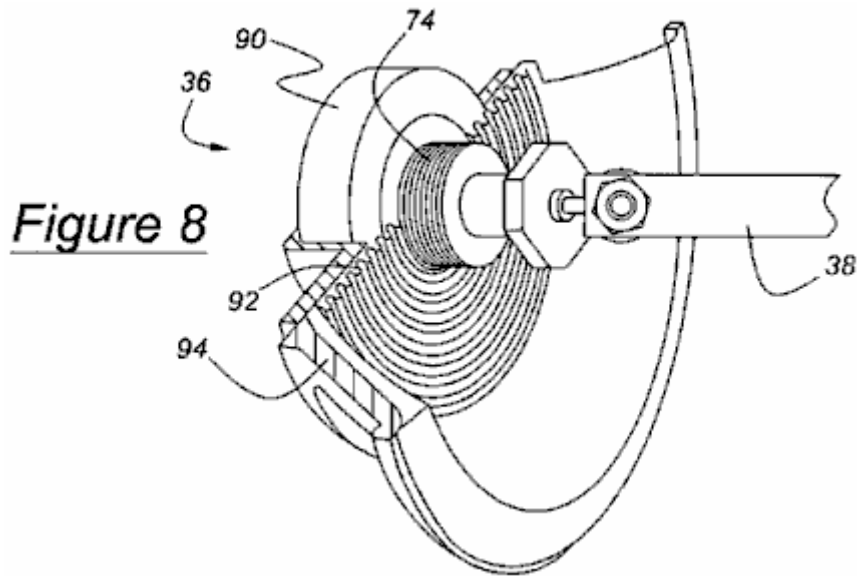

Figure 8

Fig.8 illustrates the actuator **36** for reciprocating the actuator arm **38** in response to rotation of the rotor shaft **10** and the alternating polarity of the solenoid **74**. The actuator **36**, includes the solenoid **74**, the toroidal permanent magnet **90**, an elastic flexible spider **92** for supporting the solenoid above the plane of the magnet, and a basket or frame **94**, to which the spider is secured. The actuator arm **38** is secured to solenoid **74**. The polarity of the solenoid **74** changes as rotor shaft **10** rotates, causing the solenoid and actuator arm **38** to reciprocate due to the alternating polarity of the solenoid relative to that of the toroidal permanent magnet **90**. As the solenoid polarity changes, the actuator arm **38** reciprocates linearly due to the alternating forces of attraction and repulsion of the solenoid **74** relative to the poles of the magnet **90**. The actuator arm **38** is secured to the oscillator arms **20**, **22** and **24** causing them to pivot, and the reciprocating magnets **50** – **52**, secured to the oscillator arms, to reciprocate. Alternatively, the reciprocating magnets **50** – **52** can be secured directly to the arm **38**, so that the magnets **50** – **52** reciprocate without need for an intermediary oscillating component.

It is important to note at this point in the description that, when two magnets approach each other with their poles of like polarity facing each other but slightly offset, there is a tendency for the magnets to rotate to the opposite pole of the other magnet. Therefore, in the preferred embodiment of the instant invention, the angular position at which the switch assembly of the actuator **36** changes between the states of **Fig.4** and **Fig.5** is slightly out of phase with the angular position of the rotor shaft **10** to help sling or propel the actuator arm **38** in the reverse direction at the preferred position of the rotor shaft. The optimum phase offset is approximately 5–8 degrees. This way, advantage is taken of each rotor magnet's tendency to rotate about its own magnetic field when slightly offset from the respective reciprocating magnet, and the repulsive force between like poles of the reciprocating magnets and the rotor magnets is optimised to propel the rotor magnet about the rotor axis **11**, thereby increasing the motor's overall efficiency.

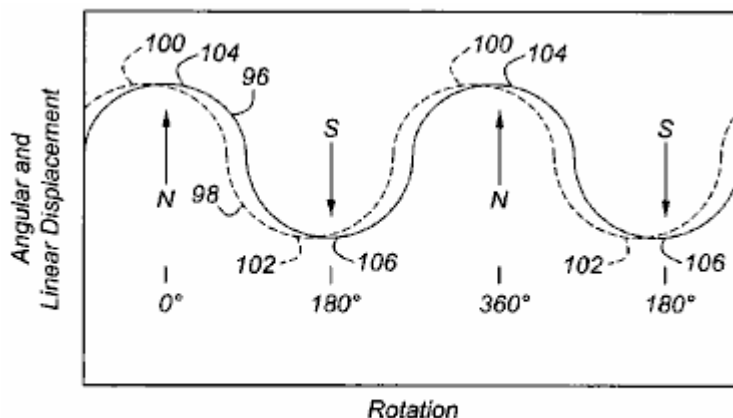

Figure 12

Fig.12 is a graph showing the angular displacement **96** of the rotor shaft **10** and linear displacement **98** of the reciprocating magnets **50** – **52**. Point **100** represents the end of the range of displacement of the reciprocating magnets **50** – **52** shown in **FIGS. 2** and **9**, and point **102** represents the opposite end of the range of displacement of the reciprocating magnets **50** – **52** shown in **FIGS. 3** and **10**. Point **104** represents the angular position of the

rotor magnets 42 – 49 when in the horizontal plane shown in FIGS. 2 and 9, and point 106 represents the angular position of the rotor magnets 42 – 49 when rotated one-half rotation to the horizontal plane shown in Fig.3 and Fig.10. Preferably, the reciprocating magnets 50 – 52 and rotor magnets 42 – 49 are out of phase: the reciprocating magnets lead and the rotor magnets lag by several degrees. The reciprocating magnets 50 – 52 reach the respective extremities of their range of travel before rotor rotation moves the rotor magnets 42 – 49 into the horizontal plane.

When the reference poles 54 and opposite poles 56 of the rotor magnets 42 – 49 and reciprocating magnets 50 – 52 are arranged as shown in Fig.2 and Fig.3, the rotor position is stable when the rotor magnets are in a horizontal plane. The rotor position is unstable in any other angular position, and it moves towards horizontal stability from any unstable position, and is least stable when the rotor magnets 42 – 49 are in a vertical plane. The degree of stability of the rotor shaft 10 is a consequence of the mutual attraction and repulsion of the poles of the rotor magnets 42 – 49 and reciprocating magnets 50 – 52 and the relative proximity among the poles. In Fig.2, the reciprocating magnets 50 – 52 are located at a first extremity of travel. In Fig.3, the reciprocating magnets 50 – 52 have reciprocated to the opposite extremity of travel, and the rotor magnets have rotated one-half revolution from the position shown in Fig.2.

When the rotor is stopped, its rotation can be easily started manually by applying torque in either direction. Actuator 36 sustains rotor rotation after it is connecting to its power source. Rotation of rotor shaft 10 about axis 11 is aided by cyclic movement of the reciprocating magnets 50 – 52, their axial location between the rotor magnet pairs 42 – 43 , 44 – 45 , 46 – 47 and 48 – 49, the disposition of their poles in relation to the poles of the rotor magnets, and the frequency and phase relationship of their reciprocation relative to rotation of the rotor magnets. Actuator 36 maintains the rotor 10 rotating and actuator arm 38 oscillating at the same frequency, the phase relationship being as described with reference to Fig.12.

With the rotor magnets 42 and 49 as shown in Fig.2, when viewed from above, the north poles 54 of the rotor magnets on the left-hand side of axis 11 face a first axial direction 110, i.e., toward the actuator 36, and the north poles 54 of the rotor magnets on the right-hand side of axis 11 face in the opposite axial direction 112, away from actuator 36. When the rotor magnets 42 – 49 are located as in Fig.2, the north poles 54 of reciprocating magnets 50 – 52 are adjacent the south poles 56 of rotor magnets 45, 47 and 49 , and the south poles 56 of reciprocating magnets 50 – 52 are adjacent the north poles 54 of rotor magnets 44, 46 and 48.

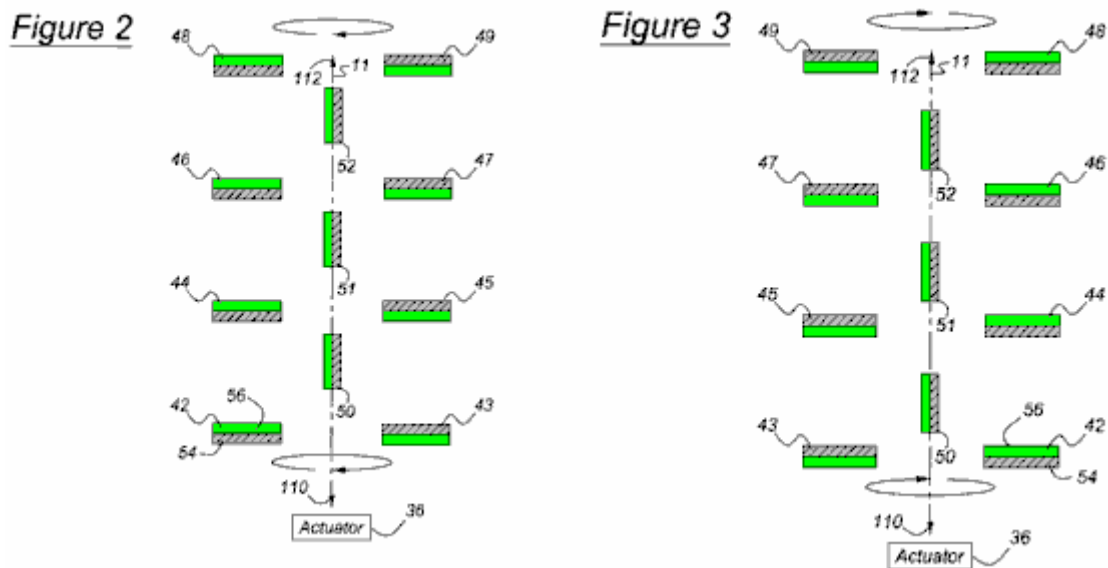

Furthermore, when the rotor shaft 10 rotates to the position shown in Fig.2, the reciprocating magnets 50 – 52 are located at, or near, one extremity of their axial travel, so that the north poles 54 of reciprocating magnets 50 – 52 are located close to the south poles 56 of rotor magnets 45, 47 and 49, respectively, and relatively more distant from the north poles 54 of rotor magnets 43, 45 and 47, respectively. Similarly, the south poles 56 of reciprocating magnets 50 – 52 are located close to the north poles of rotor magnet 44, 46 and 48, respectively, and relatively more distant from the south poles of rotor magnets 42, 44 and 46, respectively.

With the rotor magnets 42 and 49 rotated into a horizontal plane one-half revolution from the position of Fig.1B, when viewed from above as shown in Fig.3, the north poles 54 of reciprocating magnets 50 – 52 are located adjacent the south poles of rotor magnets 42, 44 and 46, and the south poles 56 of reciprocating magnets 50 – 52 are located adjacent the north poles 54 of rotor magnets 43, 45 and 47, respectively. When the rotor 10 shaft is located as shown in Fig.3, the reciprocating magnets 50 – 52 are located at or near the opposite extremity of their

axial travel from that of Fig.2, such that the north poles 54 of reciprocating magnets 50 – 52 are located close to the south poles 56 of rotor magnet 42, 44 and 46, respectively, and relatively more distant from the north poles of rotor magnets 44, 46 and 48, respectively. Similarly, when the rotor shaft 10 is located as shown in FIG. 3, the south poles 56 of reciprocating magnets 50 – 52 are located close to the north poles of rotor magnet 43, 45 and 47, respectively, and relatively more distant from the south poles of rotor magnets 45, 47 and 49, respectively.

In operation, rotation of rotor shaft 10 in either angular direction is started manually or with a starter-actuator (not shown). Actuator 36 causes reciprocating magnets 50 – 52 to oscillate or reciprocate at the same frequency as the rotational frequency of the rotor shaft 10, i.e. one cycle of reciprocation per cycle of rotation, preferably with the phase relationship illustrated in Fig.12. When the reciprocating magnets 50 – 52 are located as shown in Fig.2, the rotor shaft 10 will have completed about one-half revolution from the position of Fig.3 to the position of Fig.2.

Rotation of the rotor 10 is aided by mutual attraction between the north poles 54 of the reciprocating magnets 50 – 52 and the south poles 56 of the rotor magnets 43, 45, 47 and 49 that are then closest respectively to those north poles of reciprocating magnets 50 – 52, and mutual attraction between the south poles of reciprocating magnets 50 – 52 and the north poles of the rotor magnets 42, 44, 46 and 48 that are then closest respectively to the north poles of the reciprocating magnets.

Assume rotor shaft 10 is rotating counterclockwise when viewed from the actuator 36, and the rotor magnets 42, 44, 46 and 48 are located above rotor magnets 43, 45, 47 and 49. With the rotor shaft 10 positioned so that the reciprocating magnets 50 – 52 are approximately mid-way between the positions shown in Fig.2 and Fig.3 and moving toward the position shown in Fig.2, as rotation proceeds, the south pole of each reciprocating magnet 50 – 52 applies a downward attraction to the north pole 54 of the closest of the rotor magnets 44, 46 and 48, and the north pole 54 of each reciprocating magnet 50 – 52 attracts upwards the south pole 56 of the closest rotor magnet 45, 47 and 49. This mutual attraction of the poles causes the rotor to continue rotating counterclockwise to the position of Fig.2.

Then the reciprocating magnets 50 – 52 begin to move toward the position shown in Fig.3, and rotor inertia overcomes the steadily decreasing force of attraction between the poles as they move mutually apart, permitting the rotor shaft 10 to continue its counterclockwise rotation into the vertical plane where rotor magnets 43, 45, 47 and 49 are located above rotor magnets 42, 44, 46 and 48. As rotor shaft 10 rotates past the vertical plane, the reciprocating magnets 50 – 52 continue to move toward the position of Fig.3, the south pole 56 of each reciprocating magnet 50 – 52 attracts downward the north pole of the closest rotor magnet 43, 45 and 47, and the north pole 54 of each reciprocating magnet 50 – 52 attracts upward the south pole 56 of the closest rotor magnet 42, 44 and 46, causing the rotor 10 to rotate counterclockwise to the position of Fig.3. Rotor inertia maintains the counterclockwise rotation, the reciprocating magnets 50 – 52 begin to move toward the position shown in Fig.2, and the rotor shaft 10 returns to the vertical plane where rotor magnets 43, 45, 47 and 49 are located above rotor magnets 42, 44, 46 and 48, thereby completing one full revolution.

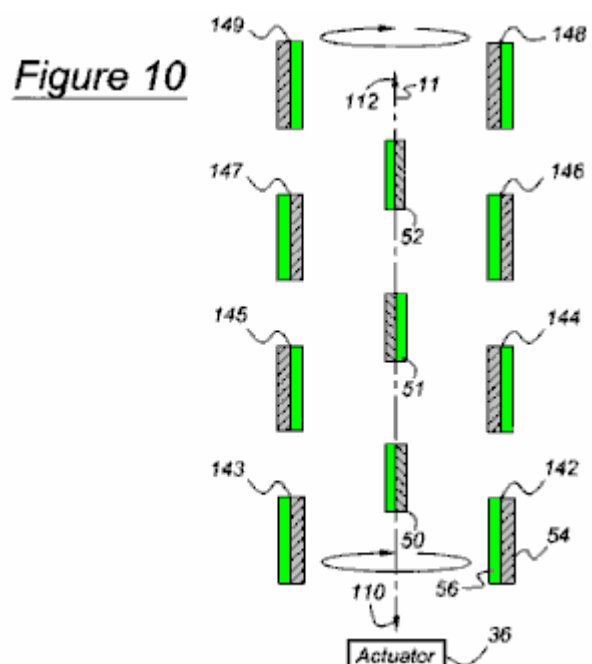
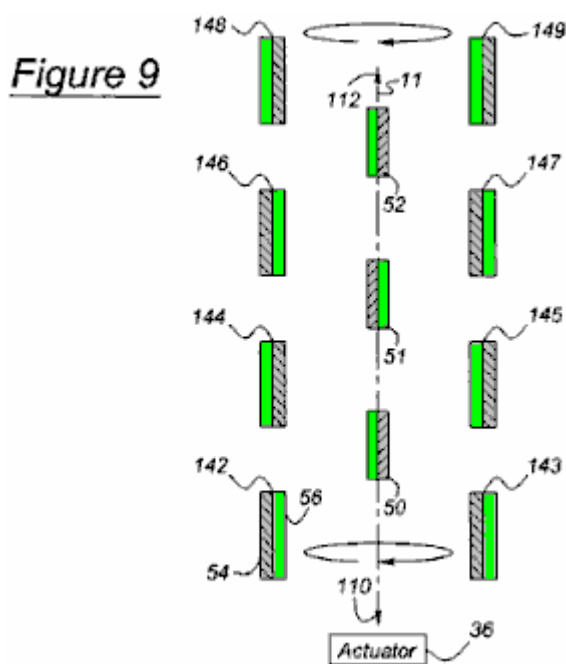

Fig.9 and **Fig.10** show a second arrangement of the motor in which the poles of the rotor magnets **142 – 149** are parallel to, and face the same direction as those of the reciprocating magnets **50 – 52**. Operation of the motor arranged as shown in **Fig.9** and **Fig.10** is identical to the operation described with reference to **Fig.2** and **Fig.3**. In the embodiment of **Fig.9** and **Fig.10**, the poles of the reciprocating magnets **50 – 52** face more directly the poles of the rotor magnets **142 – 149** in the arrangement of **Fig.2** and **Fig.3**. The forces of attraction and repulsion between the poles are greater in the embodiment of **Fig.9** and **Fig.10**, therefore, greater torque is developed. The magnitude of torque is a function of the magnitude of the magnetic forces, and the distance through which those force operate.

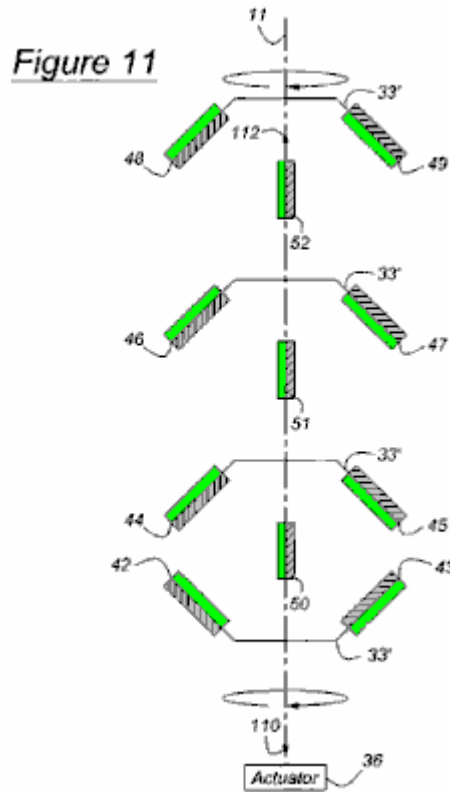

Fig.11 shows a third embodiment of the motor in which the radial outer portion of the rotor plates **33'** are skewed relative to the axis **11** such that the poles of the rotor magnets **42 – 49** are canted relative to the poles of the reciprocating magnets **50 – 52**. Operation of the motor arranged as shown in **Fig.11** is identical to the operation described with reference to **Fig.2** and **Fig.3**.

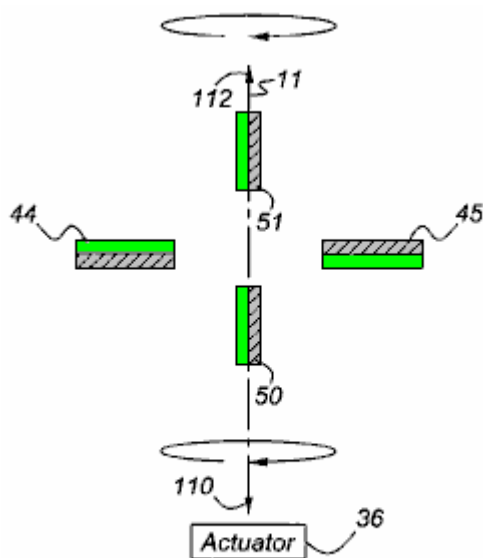

Figure 13

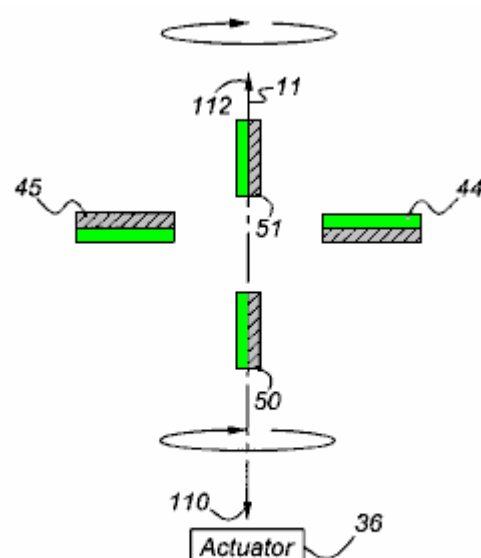

Figure 14

Fig.13 and **Fig.14** show a fourth embodiment of the motor in which each of two reciprocating magnets **50** and **51** is located on an axially opposite side of a rotor magnet pair **44** and **45**. Operation of the motor arranged as shown in **Fig.13** and **Fig.14** is identical to the operation described with reference to **Fig.2** and **Fig.3**.

The direction of the rotational output can be in either angular direction depending on the direction of the starting torque.

The motor can produce reciprocating output on actuator arm **38** instead of the rotational output described above upon disconnecting actuator arm **38** from actuator **36**, and connecting a crank, or a functionally similar device, in the drive path between the actuator and the rotor shaft **10**. The crank converts rotation of the rotor shaft **10** to reciprocation of the actuator **30**. In this case, the rotor shaft **10** is driven rotatably in either direction by the power source, and the output is taken on the reciprocating arm **38**, which remains driveably connected to the oscillating arms **20**, **22** and **24**. The reciprocating magnets **50**, **51** and **52** drive the oscillating arms **20**, **22** and **24**.

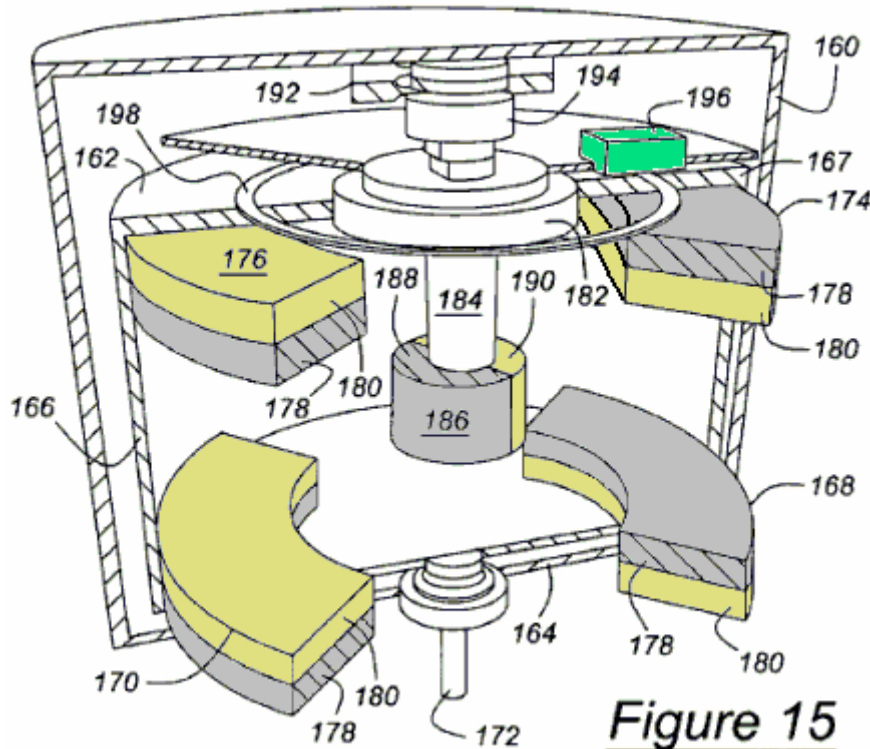

Figure 15

In the perspective cross sectional view shown in **Fig.15**, an outer casing **160** contains a motor according to this invention functioning essentially the same as the embodiment of the more efficient motor shown in **Fig.1A** and **Fig.1B**, but having a commercial appearance. The rotor includes discs **162** and **164**, which are connected by an outer drum **166** of nonmagnetic material. The upper surface **167** of drum **166** forms a magnetic shield surrounding the rotor. Mounted on the lower disc **164** are curved rotor magnets **168** and **170**, which extend angularly about a rotor shaft **172**, which is secured to the rotor. Mounted on the upper disc **162**, are curved rotor magnets **174** and **176**, which extend angularly about the rotor shaft **172**. The reference poles are **178**, and the opposite poles are **180**. A bushing **182** rotates with the rotor.

A reciprocating piston **184**, which moves vertically but does not rotate, supports reciprocating magnet **186**, whose reference pole **188** and opposite pole **190** extend angularly about the axis of piston **184**.

A solenoid magnet **192**, comparable to magnet **90** of the actuator **36** illustrated in **Fig.8**, is located adjacent a solenoid **194**, comparable to solenoid **74** of **Fig.4** and **Fig.5**. The polarity of solenoid **194** alternates as the rotor rotates. Simply stated, as a consequence of the alternating polarity of the solenoid **194**, the reciprocating piston **184** reciprocates which, in turn, continues to advance the rotor more efficiently, using the attraction and repulsion forces between the reciprocating magnets **186** and rotor magnets **168**, **170**, **174** and **176** as described above and shown in any of the different embodiments using **Fig.2**, **Fig.3**, **Fig.9**, **Fig.10**, **Fig.11**, **Fig.13** and **Fig.14**. Of course, just as the alternating polarity of the solenoid can put the motor in motion, so can the turning of the rotor, as described above. A photosensor **196** and sensor ring **198** can be used, as an alternative to the mechanical embodiment described in **Fig.4** to **Fig.7**, to determine the angular position of the rotor so as to alternate the polarity of the solenoid **194** with the rotor to correspond with the phase and cycle shown in **Fig.12**.

In accordance with the provisions of the patent statutes, the present invention has been described in what is considered to represent its preferred embodiment. However, it should be noted that the invention can be

constructed otherwise than as specifically illustrated and described without departing from its spirit or scope. It is intended that all such modifications and alterations be included insofar as they come within the scope of the appended claims or the equivalents thereof.

CLAIMS

1. A motor comprising: a rotor supported for rotation about an axis; a first pair of rotor magnets supported on the rotor, including a first rotor magnet and a second rotor magnet spaced angularly about the axis in an opposite radial direction from the first rotor magnet such that the first pair of rotor magnets rotate about the axis along a path having an outermost circumferential perimeter; a first reciprocating magnet supported for movement toward and away from the first and second rotor magnets, the first reciprocating magnet being axially disposed in a first space within a boundary defined by longitudinally extending the outermost circumferential perimeter of the first pair of rotor magnets, and the first reciprocating magnet is a permanent dipole magnet having a reference pole facing laterally from the axis and an opposite pole facing in an opposite lateral direction from the reference pole; and an actuator for moving the first reciprocating magnet cyclically toward and away from the first pair of rotor magnets without passing through a centre of rotation of the first pair of rotor magnets so as to simultaneously create repulsion and attraction forces with the first pair of rotor magnets to cyclically rotate the first pair of rotor magnets relative to the first reciprocating magnet in one rotational direction.
2. The motor of claim 1 further comprising: a second reciprocating magnet axially disposed in a second space within the boundary defined by longitudinally extending the outermost circumferential perimeter of the first pair of rotor magnets at an axial opposite side of the first pair of rotor magnets, and supported for movement toward and away from the first and second rotor magnets without passing through the centre of rotation of the first pair of rotor magnets.
3. The motor of claim 1 further comprising: a second pair of rotor magnets supported on the rotor, spaced axially from the first pair of rotor magnets, the second pair including a third rotor magnet and a fourth rotor magnet spaced angularly about the axis in an opposite radial direction from the third rotor magnet; and wherein the first reciprocating magnet is located in said first space disposed axially between the first and second rotor magnet pairs, and the actuator cyclically moves the first reciprocating magnet toward and away from the first and second pairs of rotor magnets without passing through a centre of rotation of the second pair of rotor magnets.
4. The motor of claim 1 further comprising: a second pair of rotor magnets supported on the rotor, spaced axially from the first pair of rotor magnets, the second pair including a third rotor magnet and a fourth rotor magnet spaced angularly about the axis in an opposite radial direction from the third rotor magnet; a third pair of rotor magnets supported on the rotor, spaced axially from the first and second pairs of rotor magnets, the third pair including a fifth rotor magnet and a sixth rotor magnet spaced angularly about the axis in an opposite radial direction from the fifth rotor magnet; and a second reciprocating magnet disposed in a second space located axially between the second and third rotor magnet pairs and within the boundary defined by longitudinally extending the outermost circumferential perimeter of the first pair of rotor magnets, and the second reciprocating magnet being supported for movement toward and away from the second and third pairs of rotor magnet; and wherein the first reciprocating magnet disposed in the first space is still further located axially between the first and second rotor magnet pairs, and the actuator cyclically moves the first reciprocating magnet toward and away from the first and second pairs of rotor magnets without passing through a centre of rotation of the second pair of rotor magnets, and the second reciprocating magnet toward and away from the second and third pairs of rotor magnets without passing through the centre of rotation of the second pair of rotor magnets and through a centre of rotation of a third pair of rotor magnets.
5. The motor of claim 1 further comprising: an arm supported for pivotal oscillation substantially parallel to the axis, the first reciprocating magnet being supported on the arm adjacent the first and second rotor magnets; and wherein the actuator is driveably connected to the arm.
6. The motor of claim 1 wherein: the first and second rotor magnets are permanent dipole magnets, the first rotor magnet having a reference pole facing axially away from the first reciprocating magnet and an opposite pole facing axially toward the first reciprocating magnet, the second rotor magnet having a reference pole facing axially toward the first reciprocating magnet and an opposite pole facing axially away from the first reciprocating magnet.
7. The motor of claim 1 wherein: the first and second rotor magnets are magnet is a permanent dipole magnets magnet, the first rotor magnet having a reference pole facing axially away from the first reciprocating magnet and an opposite pole facing axially toward the first reciprocating magnet, the second rotor magnet having a reference pole facing axially toward the first reciprocating magnet and an opposite pole facing axially away from the first reciprocating magnet; and the motor further comprising: a second pair of rotor magnets supported on the rotor, spaced axially from the first pair of rotor magnets, the second pair including a third

permanent dipole rotor magnet having a reference pole facing axially toward the first reciprocating magnet and an opposite pole facing away from the first reciprocating magnet, and a fourth permanent dipole rotor magnet spaced angularly about the axis in an opposite radial direction from the third rotor magnet, the fourth permanent dipole rotor magnet having a reference pole facing axially away from the first reciprocating magnet and an opposite pole facing toward the first reciprocating magnet; and wherein the first reciprocating magnet disposed in said first space is still further located axially between the first and second rotor magnet pairs, and the actuator cyclically moves the first reciprocating magnet toward and away from the first and second pairs of rotor magnets without passing through a centre of rotation of the second pair of rotor magnets.

8. The motor of claim 1 wherein: the first and second rotor magnets are permanent dipole magnets, each rotor magnet having a reference pole facing in a first lateral direction relative to the reference pole of the first reciprocating magnet and an opposite pole facing in a second lateral direction opposite the first lateral direction of the respective rotor magnet.
9. The motor of claim 1 wherein: the first and second rotor magnets are permanent dipole magnets, each rotor magnet having a reference pole facing in a first lateral direction relative to the reference pole of the first reciprocating magnet and an opposite pole facing in a second lateral direction opposite the first lateral direction of the respective rotor magnet; and the motor further comprising: a second pair of rotor magnets supported for rotation on the rotor about the axis, the second pair of rotor magnets being spaced axially from the first pair of rotor magnets, the second pair including a third permanent dipole rotor magnet and a fourth permanent dipole rotor magnet, the third and fourth rotor magnets each having a reference pole facing in the second lateral direction and an opposite pole facing in the first lateral direction, and wherein the first reciprocating magnet disposed in the first space is still further located axially between the first and second rotor magnet pairs, and the actuator cyclically moves the first reciprocating magnet toward and away from the first and second pairs of rotor magnets without passing through a centre of rotation of the second pair of rotor magnets.
10. The motor of claim 3 further comprising: a third pair of rotor magnets supported on the rotor, spaced axially from the first and second pairs of rotor magnets, the third pair including a fifth rotor magnet and a sixth rotor magnet spaced angularly about the axis in an opposite radial direction from the fifth rotor magnet; a second reciprocating magnet located in a second space within the boundary defined by longitudinally extending the outermost circumferential perimeter of the first pair of rotor magnets and axially between the second and third rotor magnet pairs, and the second reciprocating magnet being supported for movement toward and away from the second and third pairs of rotor magnet; a first arm supported for pivotal oscillation substantially parallel to the axis, the first reciprocating magnet being supported on the arm adjacent the first and second pairs of rotor magnets; and a second arm supported for pivotal oscillation substantially parallel to the axis, the second reciprocating magnet being supported on the arm adjacent the second and third pairs of rotor magnets; and wherein the actuator is driveably connected to the first and second arms.
11. A motor comprising: a rotor supported for rotation about an axis; a first pair of rotor magnets supported on the rotor, including a first rotor magnet and a second rotor magnet spaced angularly about the axis from the first rotor magnet such that the first pair of rotor magnets rotate about the axis along a circumferential path having an outermost perimeter; a first arm supported for pivotal oscillation along the axis, located adjacent the first and second rotor magnets; a first reciprocating magnet, supported on the first arm for movement toward and away from the first and second rotor magnets, the first reciprocating magnet being disposed axially within a first space within a boundary defined by longitudinally extending the outermost perimeter of the first circumferential path of the first pair of rotor magnets; a second pair of rotor magnets supported on the rotor, spaced axially from the first pair of rotor magnets, the second pair including a third rotor magnet, and a fourth rotor magnet spaced angularly about the axis from the third rotor magnet; a third pair of rotor magnets supported on the rotor, spaced axially from the first and second pairs of rotor magnets, the third pair including a fifth rotor magnet, and a sixth rotor magnet spaced angularly about the axis from the fifth rotor magnet; a second arm supported for pivotal oscillation along the axis between the second and third pairs of rotor magnets; a second reciprocating magnet located axially between the second and third rotor magnet pairs and supported on the second arm for movement toward and away from the second and third pairs of rotor magnet; and an actuator for moving the first reciprocating magnet cyclically toward and away from the first pair of rotor magnets without passing through a centre of rotation of the first pair of rotor magnets so as to simultaneously create repulsion and attraction forces with the first pair of rotor magnets to cyclically rotate the first pair of rotor magnets relative to the first reciprocating magnet in one rotational direction; and wherein the first reciprocating magnet disposed in the first space is still further located axially between the first and second rotor magnet pairs, and the actuator cyclically moves the first arm and first reciprocating magnet toward and away from the first and second pairs of rotor magnets without passing the first reciprocator magnet through a centre of rotation of the second pair of rotor magnets, and moves the second arm and second reciprocating magnet toward and away from the second and third pairs of rotor magnets without passing the second reciprocator magnet through the centre of rotation of the second pair of rotor magnets and through a centre of rotation of the third pair of rotor magnets.

12. The motor of claim 11 wherein the actuator further comprises: a rotor shaft driveably connected to the rotor for rotation therewith; first and second bridge plates, mutually angularly aligned about the axis, extending over a first angular range about the axis; third and fourth bridge plates, offset axially from the first and second bridge plates, mutually angularly aligned about the axis, extending over a second angular range about the axis; an electric power supply including first and second terminals; a first contact connecting the first power supply terminal alternately to the first bridge plate and the third bridge plate as the rotor rotates; a second contact connecting the second power supply terminal alternately to the second bridge plate and the fourth bridge plate as the rotor rotates; a toroidal permanent magnet; a solenoid supported above a pole of the toroidal permanent magnet, including first and second terminals; a third contact connecting the first solenoid terminal alternately to the first and second power supply terminals through the first and fourth bridge plates and first contact as the rotor rotates; a fourth contact alternately connecting and disconnecting the second power supply terminal and the second solenoid terminal as the rotor rotates; and a fifth contact alternately connecting and disconnecting the first power supply terminal and the second solenoid terminal as the rotor rotates.
13. The motor of claim 11 wherein the actuator further comprises: a toroidal permanent magnet; an A.C. power source; and a solenoid supported for displacement adjacent a pole of the toroidal permanent magnet, including first and second terminals electrically connected to the power source.
14. A motor comprising: a rotor supported for rotation about an axis; a first rotor magnet supported for rotation about the axis along a first circumferential path having an outermost perimeter and a centre at the axis, the first rotor magnet having a first permanent reference pole facing laterally toward the axis and a first permanent opposite pole facing in an opposite lateral direction toward the first reference pole; a pair of reciprocating magnets supported for movement toward and away from the rotor magnet, including a first reciprocating magnet and a second reciprocating magnet spaced axially from the first rotor magnet, each reciprocating magnet being at least partially disposed within a first axial space having a boundary defined by longitudinally extending the outermost perimeter of the first circumferential path of the first rotor magnet, wherein the rotor magnet is located axially between the first and second reciprocating magnets; and an actuator for moving the pair of reciprocating magnets cyclically toward and away from the rotor magnet without passing through the centre of the first circumferential path so as to simultaneously create repulsion and attraction forces with the first rotor magnet to cyclically rotate the rotor magnet relative to the pair of reciprocating magnets in one rotational direction.
15. The motor of claim 14 wherein the first and second reciprocating magnets are permanent dipole magnets with each having a reference pole facing laterally from the axis and an opposite pole facing in an opposite lateral direction from its corresponding reference pole.
16. The motor of claim 15 further comprising: a second rotor magnet spaced axially from the first rotor magnet, the second rotor magnet being supported for rotation about the axis along a second circumferential path having an outermost perimeter about the centre, the second rotor magnet including a second permanent reference pole facing laterally toward the axis and a second permanent opposite pole facing in an opposite lateral direction toward the second reference pole; and wherein the second reciprocating magnet is located axially between the first and second rotor magnets and at least partially within a second axial space having a boundary defined by longitudinally extending the outermost perimeter of the second circumferential path of the second rotor magnet, and the actuator cyclically moves the second reciprocating magnet away from and towards the second rotor magnet.

The Magnetic Motor of Charles Flynn

US Patent 5,455,474

3rd October 1995

Inventor: Charles Flynn

MAGNETIC MOTOR CONSTRUCTION

This patent gives details of a permanent magnet motor which uses electromagnet shielding to achieve continuous rotation. The input power is very small with even a 9-volt battery being able to operate the motor. The output power is substantial and operation up to 20,000 rpm is possible. Construction is also very simple and well within the capabilities of the average handyman. It should be realised that the power of this motor comes from the permanent magnets and not from the small battery input used to prevent lock-up of the magnetic fields.

ABSTRACT

The present invention is a motor with permanent magnets positioned so that there is magnetic interaction between them. A coil placed in the space between the permanent magnets is used to control the magnetic interaction. This coil is connected to a source of electric potential and controlled switching so that closing the switch places a voltage across the coil and affects the magnetic interaction between the permanent magnets as to produce rotational movement of the output shaft.

US Patent References:

3096467	Brushless d. c. motor with permanent magnet rotor	July, 1963	Angus et al.	318/138
3569806	Starting Arrangement for Solid-State Motor	March, 1971	Brailsford	318/254
3670189	Gated Permanent Magnet Motor	June, 1972	Monroe	310/181
3796039	Electric Micromotor	March, 1974	Lucien	310/268
3883633	Commutatorless Motor	May, 1975	Kohler	310/152
4151431	Permanent Magnet Motor	April, 1979	Johnson	310/12
4187441	High-power-density Brushless DC Motor	February, 1980	Oney	310/112
4758756	Vernier-type Electrodynamical Machine	July, 1988	Pouillange	310/152
4875110	Rotary-head Apparatus with Motor Magnet	October, 1989	Kazama	310/268
4972112	Brushless DC Motor	November, 1990	Kim	310/181
5179307	Direct Current Brushless Motor	January, 1993	Porter	310/268

Foreign References:

DE210005	July, 1960	310/181
JP0025153	February, 1982	310/181
JP01521078	September, 1982	310/152
JP0002840	January, 1987	310/152

BACKGROUND OF THE INVENTION

The present invention is an improvement over the inventions disclosed in patent applications 07/322,121 and 07/828,703. The devices disclosed in those applications relate to means to produce useful energy using permanent magnets as the driving source. This is also true of the present invention which represents an important improvement over the known constructions and one which is simpler to construct, can be made to be self starting, is easier to adjust, and is less likely to get out of adjustment. The present construction is also relatively easy to control, is relatively stable and produces an amazing amount of output energy considering the source of driving energy that is used. The present construction makes use of permanent magnets as the source of driving energy but shows a novel means of controlling the magnetic interaction between the magnet members in a manner which is relatively rugged, produces a substantial amount of output energy and torque, and in a device capable of being used to generate substantial amounts of energy that is useful for many different purposes.

The present invention resides has a fixed support structure with one or more fixed permanent magnets such as an annular permanent magnet mounted on it with the pole faces of the permanent magnet on opposite faces of the magnet. The device has one or more relatively flat coils positioned around the edge of one of the faces of the magnet, and a shaft extends through the permanent magnet with one or more other permanent magnets attached to it. The spaced permanent magnets and the fixed permanent magnet have their polarities arranged to produce a magnetic interaction between them. The device also includes a circuit for selectively and sequentially energising the coils to control the magnetic interaction between the magnets in such a manner as to produce

rotation between them. Various methods can be used to control the application of energy to the coils including a timer or a control mechanism mounted on the rotating shaft. This design can be made to be self-starting or to be started with some initial help to establish rotation.

OBJECTS OF THE INVENTION

It is a principal object of the present invention to teach the construction and operation of a relatively simple, motor-like device using permanent magnets in an unique manner to generate rotational or other forms of movement.

Another object is to teach the construction and operation of a relatively simple, motor-like device having novel means for coupling and/or decoupling relatively moveable permanent magnets to produce motion.

Another object is to provide novel means for controlling the coupling and decoupling of relatively moveable permanent magnets.

Another object is to make the generation of rotational energy less expensive and more reliable.

Another object is to teach a novel way of generating energy by varying magnetic interaction forces between permanent magnets.

Another object is to provide an inexpensive way of producing energy.

Another object is to provide a substitute source of energy for use in places where conventional motors, generators and engines are used.

These and other objects and advantages of the present invention will become apparent after considering the following detailed specification of preferred embodiments in conjunction with the accompanying drawings.

BRIEF DESCRIPTION OF THE DRAWINGS

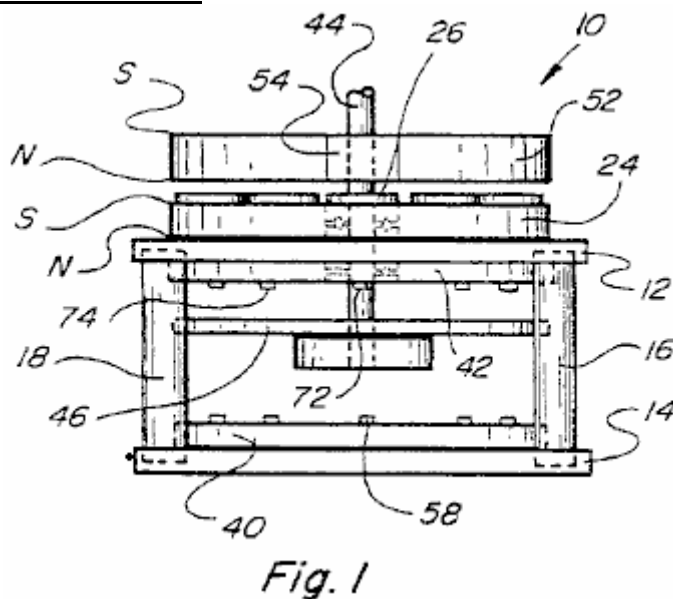

Fig.1 is a side view of a magnetically powered device constructed according to the present invention.

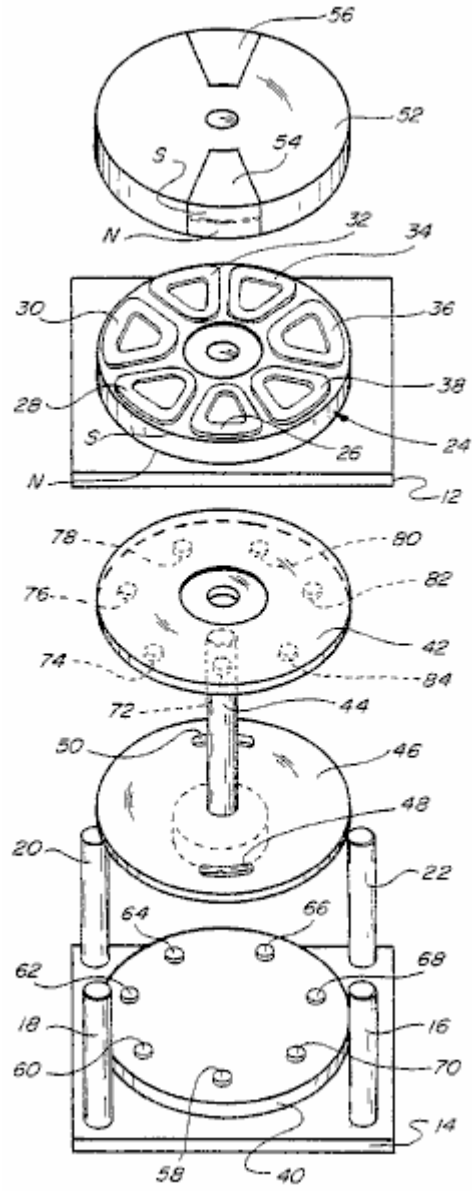

Fig. 2

Fig.2 is an exploded view of the device shown in Fig.1.

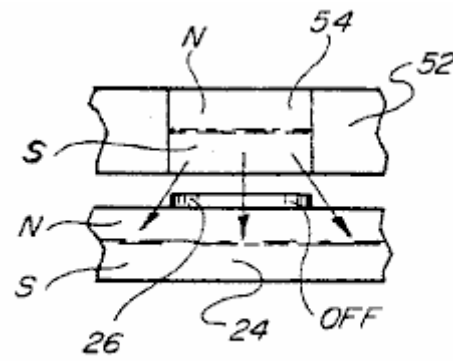

Fig. 3

Fig.3 is a fragmentary side view of one of the movable magnets and the fixed magnet, in one position of the device.

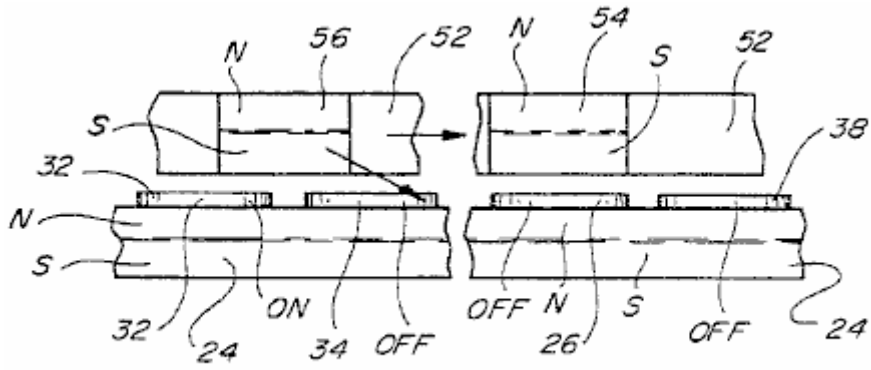

Fig. 4

Fig.4 is a view similar to Fig.3 but showing the relationship between the other movable magnets and the fixed magnet in the same rotational position of the device.

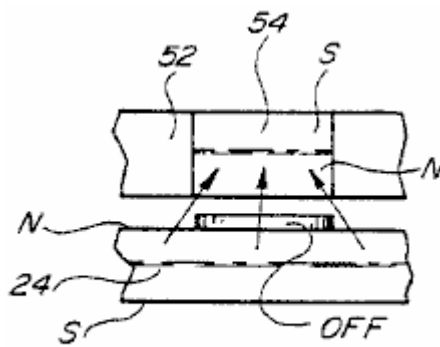

Fig. 5

Fig.5 is a fragmentary view similar to Fig.3 but showing a repulsion interaction between the relatively movable permanent magnets.

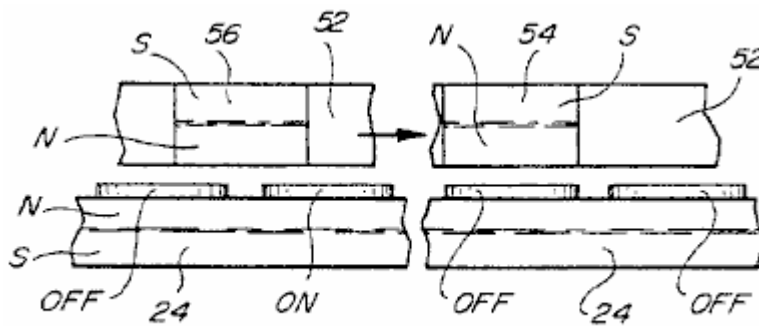

Fig. 6

Fig.6 is a view similar to Fig.4 for the condition shown in Fig.5.

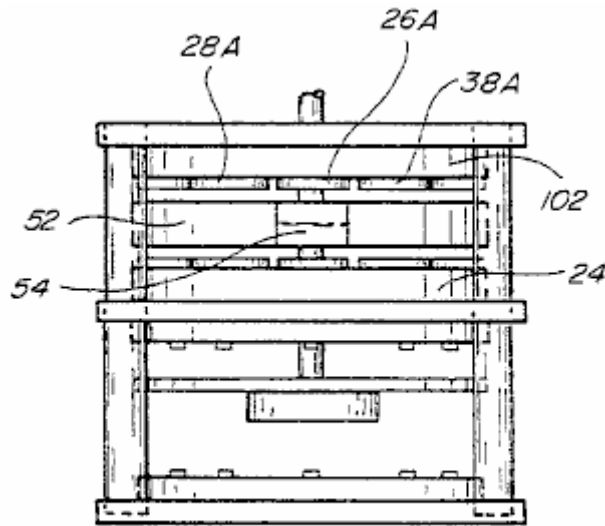

Fig. 7

Fig.7 is a side view showing another embodiment which is capable of producing even greater energy and torque.

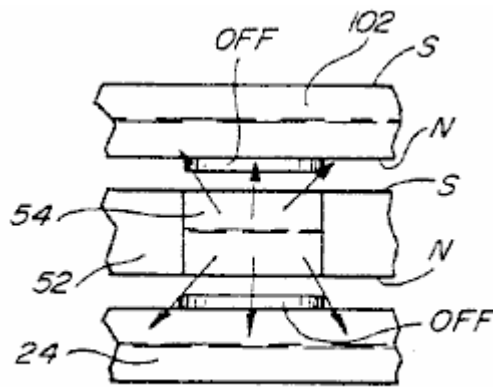

Fig. 8

Fig.8 is a fragmentary elevational view similar to Fig.3 for the device of Fig.7.

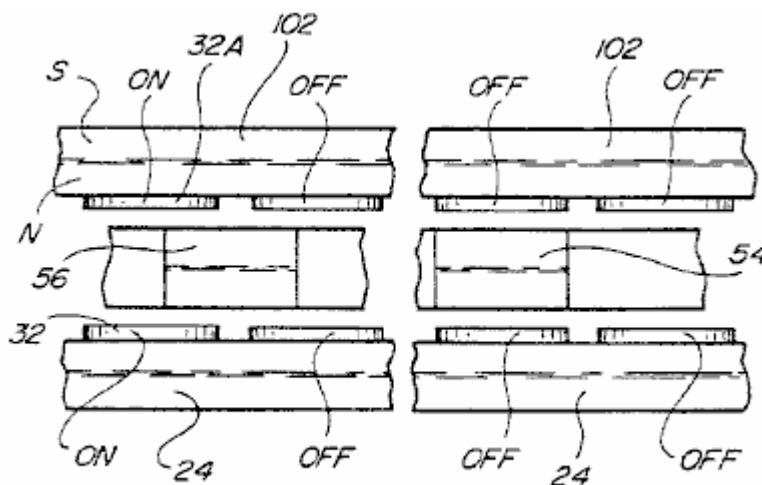

Fig. 9

Fig.9 is a view similar to Fig.4 for the construction shown in Fig.7.

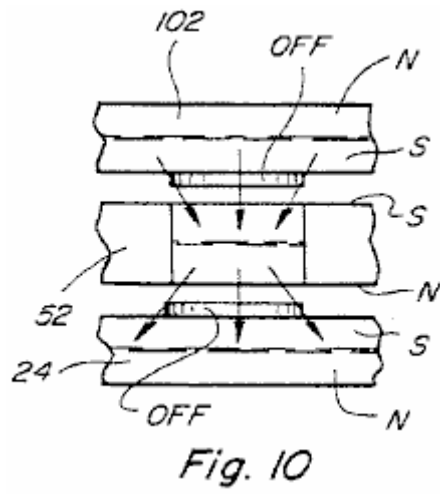

Fig.10 is a view similar to Fig.3 for the device shown in Fig.7 but with the polarity of one of the fixed permanent magnets reversed.

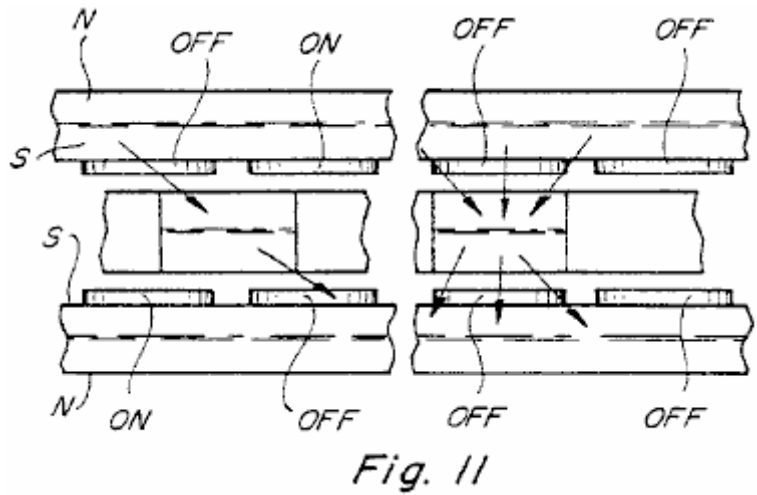

Fig.11 is a fragmentary view similar to Fig.4 for the device as shown in Fig.7 and Fig.10.

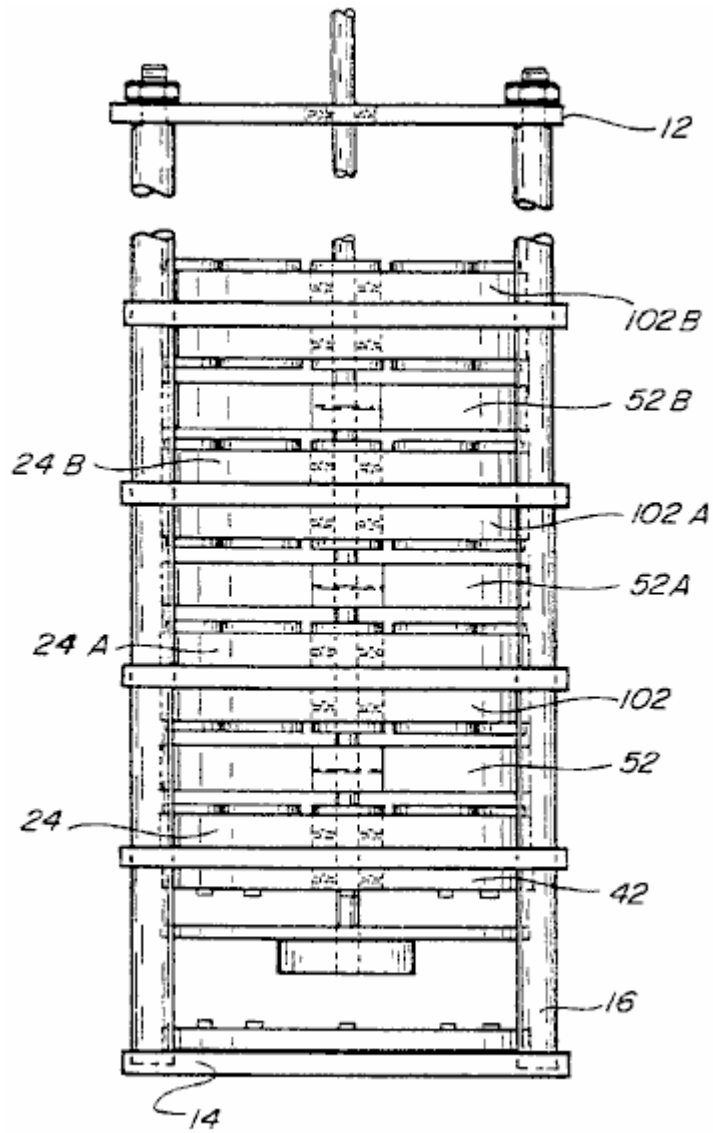

Fig. 12

Fig.12 is a side elevational view of another embodiment of the device.

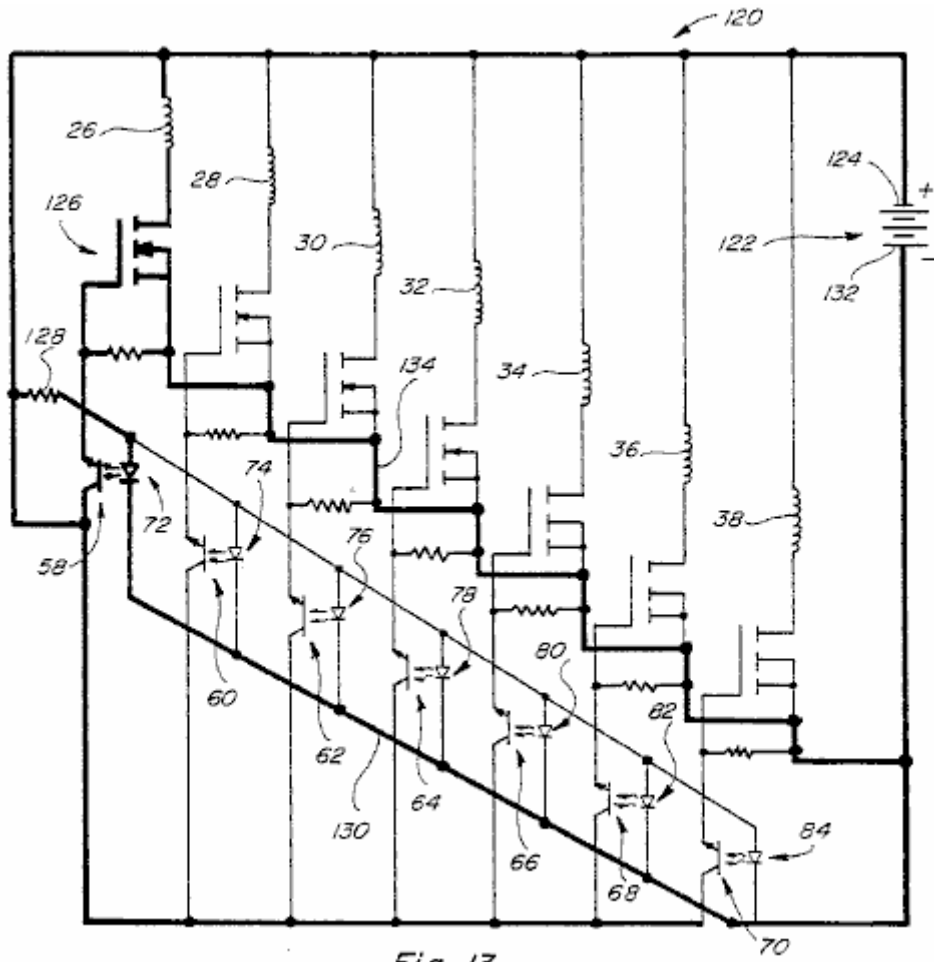

Fig. 13

Fig.13 is a schematic circuit diagram of the circuit for the devices of Figs. 1, 7 and 12.

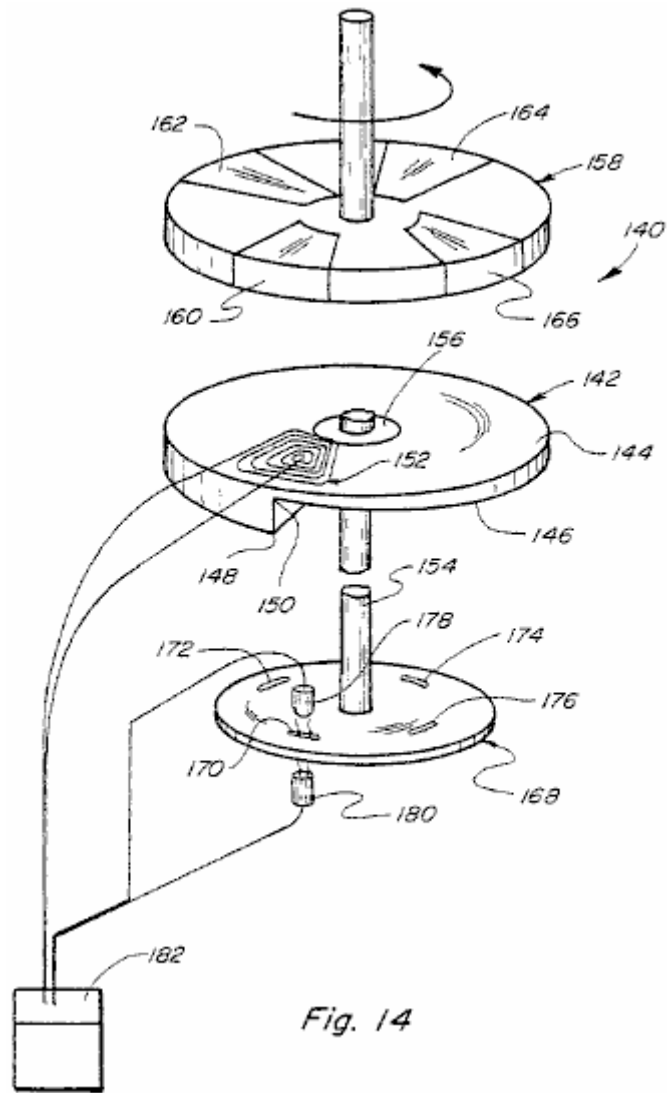

Fig. 14

Fig.14 is a perspective view of another embodiment.

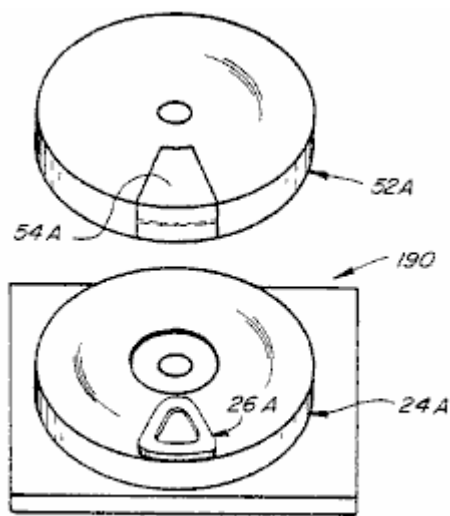

Fig. 15

Fig.15 is a simplified embodiment of the device showing the use of one rotating magnet and one coil positioned in the plane between the rotating and stationary magnets.

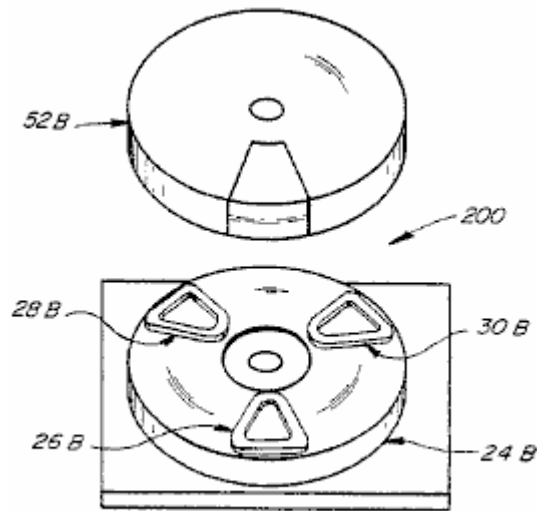

Fig. 16

Fig.16 is a simplified embodiment of the device showing use of one movable magnet and three coils arranged to be in a plane between the rotating and stationary magnets.

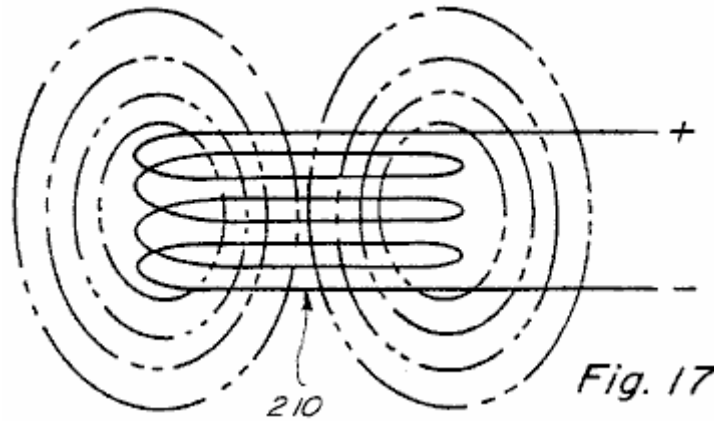

Fig. 17

Fig.17 is a side view of an air coil with a voltage applied across it and showing in dotted outline the field of the coil.

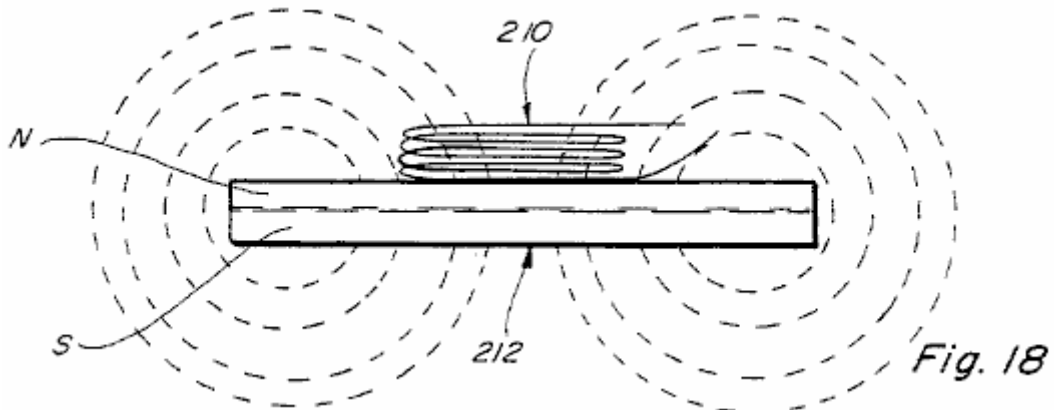

Fig. 18

Fig.18 is a view similar to Fig.17 but showing the air coil positioned adjacent to one side of a permanent magnet showing in dotted outline the magnetic field of the permanent magnet with no electric potential applied across the air coil.

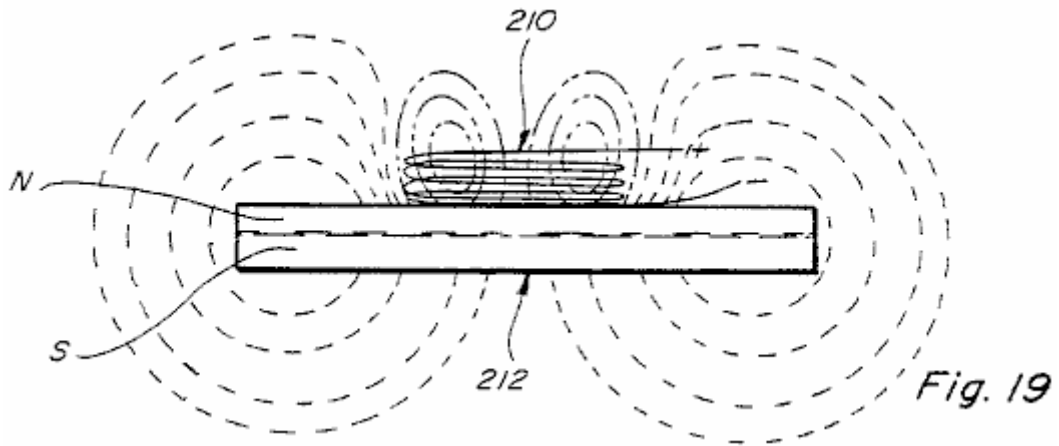

Fig.19 is a side view similar to Fig.18 with an electric potential applied across the air coil, showing in dotted outline the shapes of the electric field of the air coil and the magnetic field of the permanent magnet.

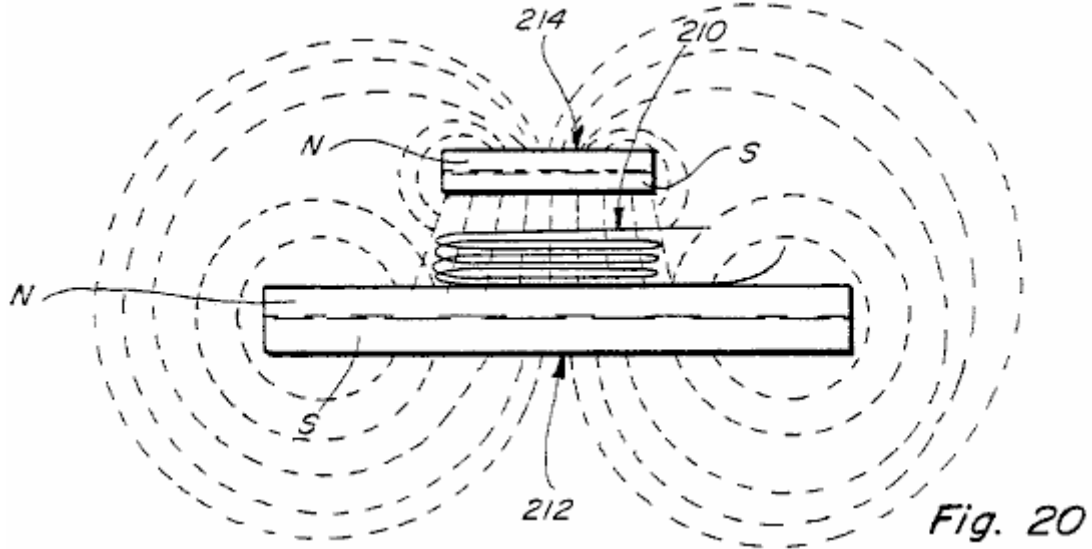

Fig.20 is a side view similar to Fig.19 but showing a second permanent magnet positioned above the first permanent magnet and showing in dotted outline the magnetic fields of the two permanent magnets when no electric potential is connected across the air coil.

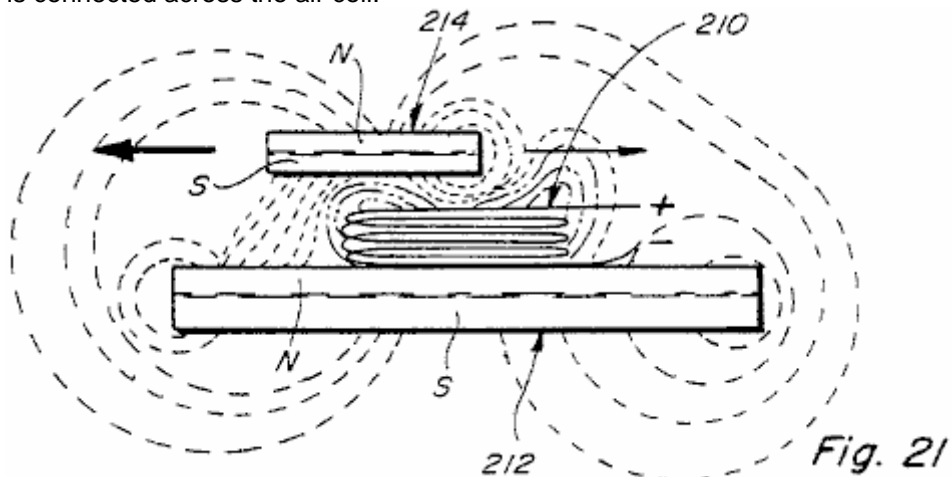

Fig.21 is a view similar to Fig.20 but with the permanent magnets in an different relative position and with a voltage applied across the air coil, said view showing the shapes of the electro-magnetic field of the air coil and the modified shapes of the magnetic fields of the two permanent magnets; and

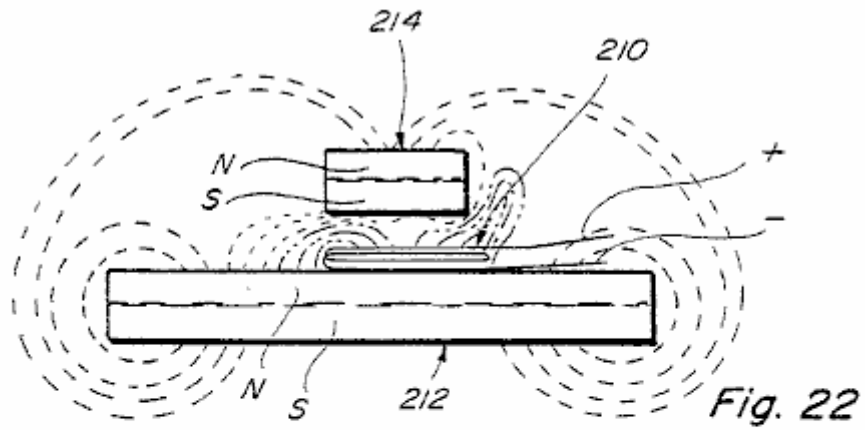

Fig. 22

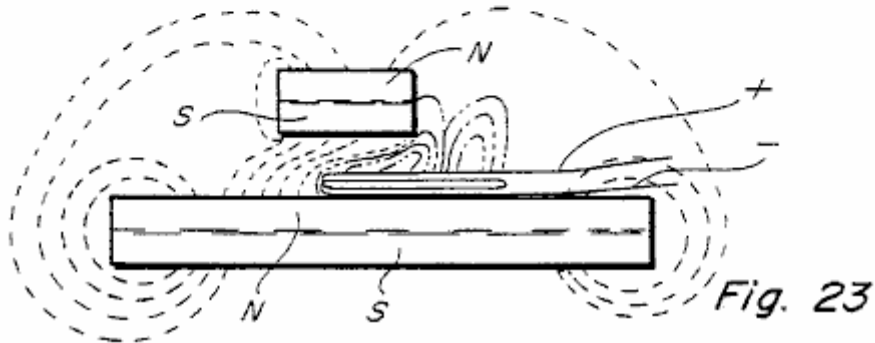

Fig. 23

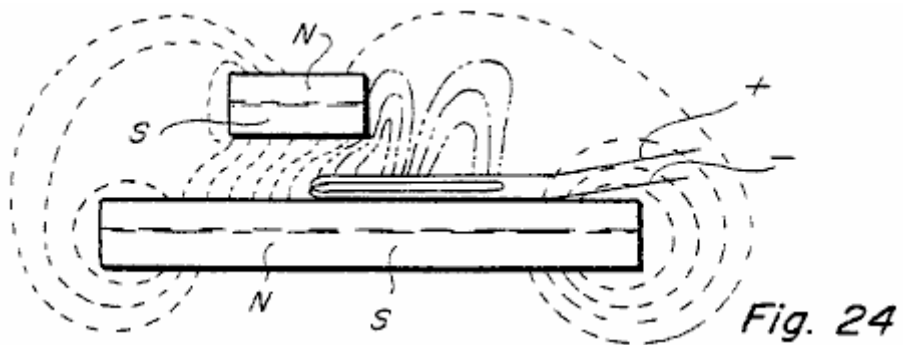

Fig. 24

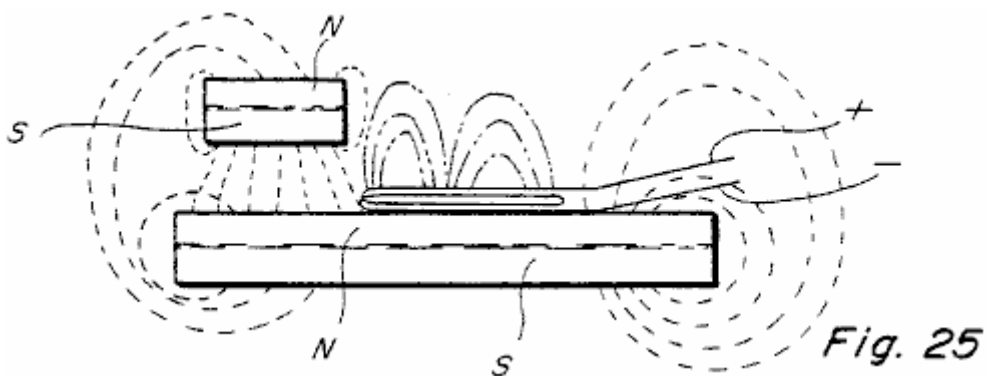

Fig. 25

Fig.22 to Fig.25 are similar to Fig.21 and show the electro-magnetic field of the air coil and the magnetic fields of the magnets in four different relative positions of the permanent magnets.

DETAILED DESCRIPTION

In the drawings, the number 10 refers to a device constructed according to the present invention. The device 10 includes a stationary base structure including an upper plate 12, a lower plate 14, and spaced posts 16-22 connected between them.

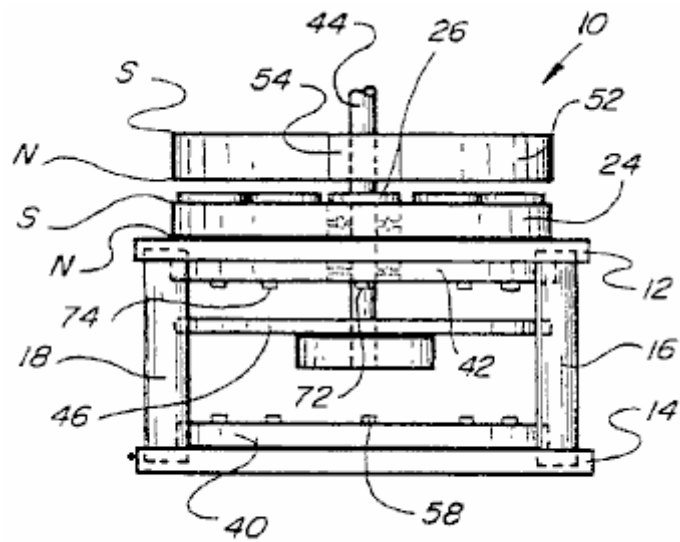

Fig. 1

Mounted on the upper plate 12 is a fixed permanent magnet 24 shown annular in shape which has its North pole adjacent to the upper surface of plate 12 and its South pole facing away from plate 12.

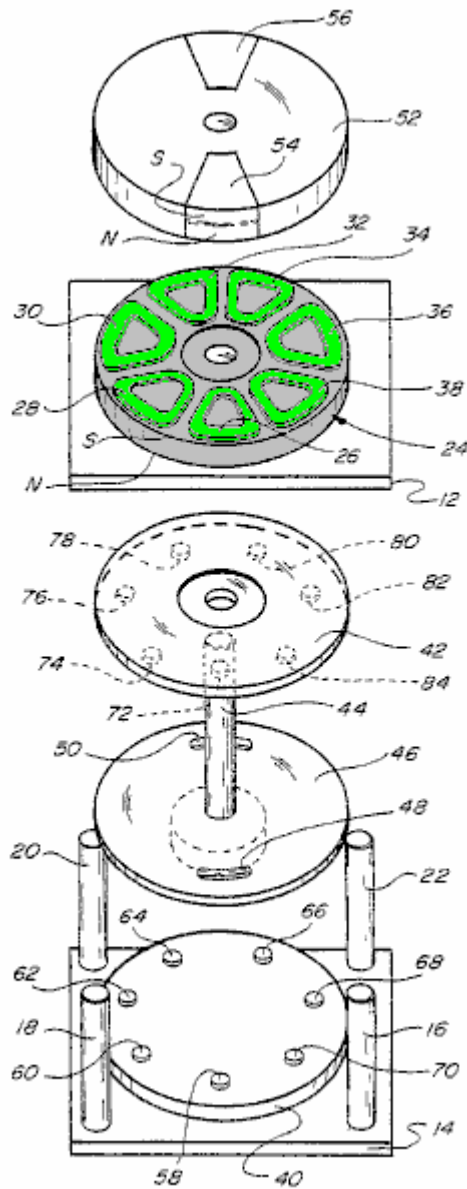

Fig. 2

Referring to **Fig.2**, the permanent magnet **24** is shown having seven coils **26-38** mounted flat on its upper surface. Seven coils are shown, and the coils **26-38** have electrical connections made through plate **12** to other circuit members which will be described later in connection with **Fig.13**. Another member **40** is mounted on the upper surface of the lower plate **14** and a similar member **42** is mounted on the underside of the plate **12**.

A shaft **44**, (shown oriented vertically for convenience) extends through aligned holes in the members **42**, **12** and **24**. The lower end of shaft **44** is connected to disk **46** which has a pair of curved openings **48** and **50** shown diametrically opposite to each other, a little in from the edge of disc **46**. The purpose of these openings **48** and **50** will be explained later on.

Shaft **44** is also connected to another disc **52** which is located on the shaft so as to be positioned adjacent to the coils **26-38**. Disc **52** has a pair of permanent magnets **54** and **56** mounted on or in it positioned diametrically opposite to each other. Magnets **54** and **56** have their north and south poles oriented as shown in **Fig.2**, that is with north poles shown on their lower sides and their south poles on the upper sides. This is done so that there will be mutual magnetic attraction and coupling between the magnets **54** and **56** and the fixed magnet **24**. The polarity of the magnets **54** and **56** and/or of the magnet **24** can also be reversed if desired for some purposes to produce relative magnetic repulsion between them.

Referring again to **Fig.2**, the lower plate **40** is shown having a series of phototransistors **58-70** mounted on its upper surface and spaced out as shown. These phototransistors are positioned under the centres of the coils **26-38** which are mounted on magnet **24**. An equal number of infra red emitters **72-84** are mounted on the under surface of the member **42** aligned with the phototransistors. There are seven infra red emitters **72-84** shown, each of which is in alignment with a respective one of the seven phototransistors **58-70** and with one of the seven coils **26-38**. This arrangement is such that when the shaft **44** and the components attached to it, including discs **46** and **52**, rotate relative to the other members including magnet **24**, the curved openings **48** and **50** pass under the infra red emitters and cause the phototransistors to switch on for a predetermined time interval. This establishes a sequence of energised circuits which powers coils **26-38**, one at a time, which in turn, causes a momentary interruption of the magnetic interaction between one of the permanent magnets **54** and **56** and magnet **24**.

When a coil is mounted on top of a permanent magnet such as permanent magnet **24** and energised it acts to concentrate the flux in a symmetrical magnetic field resulting in a non-symmetrical field when another permanent magnet is above the coil on magnet **24**. This results in uneven or non-uniform forces being produced when the coil is energised and this causes a torque between the two permanent magnets, which tries to move one of the permanent magnets relative to the other.

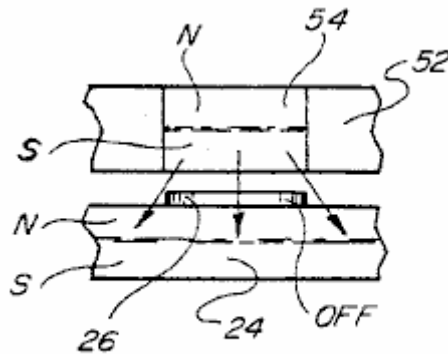

Fig. 3

Fig.3 shows the position when one of the magnets **54** is located immediately above one of the coils, say, coil **26**. In this position there would be magnetic coupling between the magnets **54** and **24** so long as there is no voltage across the coil **26**. However, if a voltage is placed across the coil **26** it will interrupt the magnetic coupling between the magnets **54** and **24** where the coil is located. This means that if there is any torque developed, it will be developed to either side of the coil **26**. Without energising the coil **26** there will be full attraction between the magnets **24** and **54** and no rotational force will be produced.

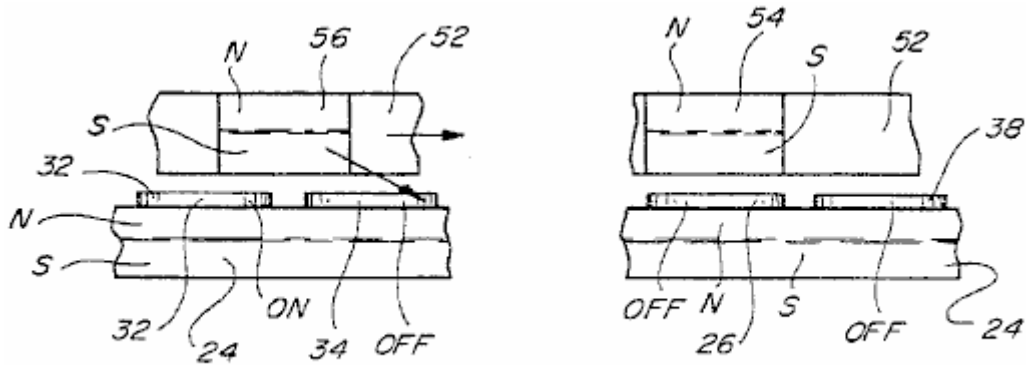

Fig. 4

Referring to **Fig.4** there is shown the relative positions of the movable magnets **54** and **56** for one position of disc **52**. For example, the magnet **54** is shown located immediately above the coil **26** while the magnet **56** is shown straddling portions of the coils **32** and **34**. If, in this position, coil **32** is energised but coils **34** and **26** are not energised, then the magnetic coupling between magnet **56** and magnet **24** will be oriented at an angle shown illustrated by the arrow in **Fig.4**, and this attractive coupling will tend to move disc **52** to the right. Since coil **26** is not powered up, there is full coupling between magnet **54** and magnet **24** but this has no effect since it does not have a directional force. At the same time, coil **38** which is the next coil over which the magnet **54** will move, is also not powered up and so it will have no rotational effect on disc **52**.

As disc **52** continues to rotate, different coils in the group **26-38** will be energised in sequence to continue to produce a rotational magnetic coupling force between disc **52** and magnet **24**. It should be noted, however, that all of the rotational force is produced by interaction between the permanent magnets and none of the rotational force is produced by the coils or by any other means. The coils are merely energised in sequence to control where the magnetic interaction occurs, and this is done in a manner to cause disc **52** to rotate. It should also be understood that one, two, or more than two, permanent magnets such as the permanent magnets **54** and **56** can be mounted on the rotating disc **52**, and the shape and size of the rotating disc **52** can be adjusted accordingly to accommodate the number of permanent magnets mounted in it. Also, disc **52** can be constructed of a non-magnetic material, the only requirement being that sufficient structure be provided to support the permanent magnets during rotation. This means that disc **52** need not necessarily be constructed to be round as shown in the drawing.

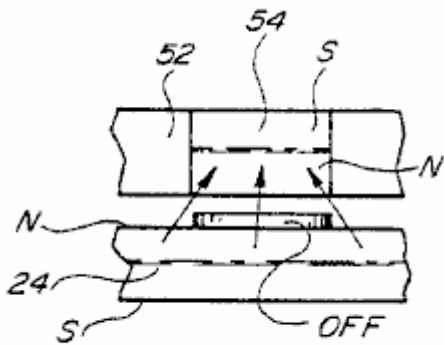

Fig. 5

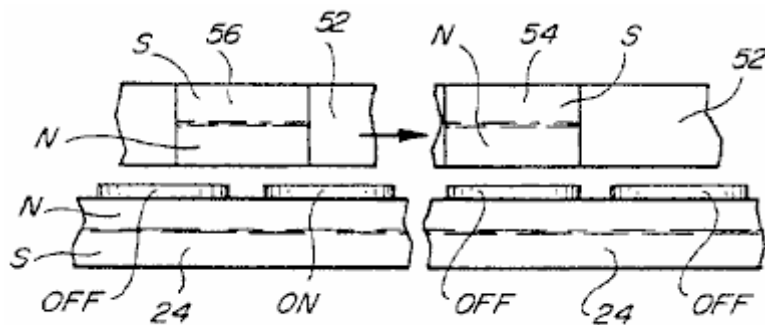

Fig. 6

Fig.5 and **Fig.6** are similar to **Fig.3** and **Fig.4** but show a construction where the permanent magnets **54** and **56** are turned over so that instead of having their north poles facing magnet **24** they have their south poles facing magnet **24** but on the opposite side of the coils such as coils **26-38**. The construction and operation of the modified device illustrated by **Fig.5** and **Fig.6** is similar to that described above except that instead of producing magnetic attraction forces between the magnets **54** and **56** and the magnet **24**, magnetic repulsion forces are produced, and these repulsion forces can likewise be used in a similar manner to produce rotation of the member **52**, whatever its construction.

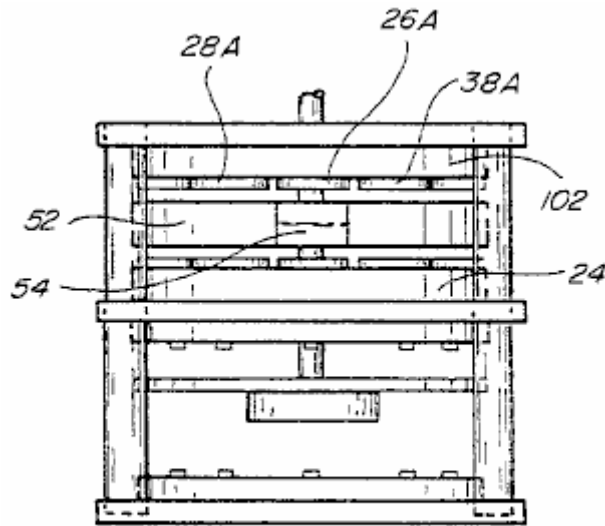

Fig. 7

Fig.7 shows a modified embodiment which includes all of the elements shown in **Fig.1** and **Fig.2** but in addition has a second stationary permanent magnet **102** which is mounted above rotating disc **52** and has its coil members such as coil members **26A-38A** mounted on its underside. Magnet **102** operates with the magnets **54** and **56** similarly to the magnet **24** and can operate in precisely the same manner, that is by producing attraction force between the magnet members or by producing repulsion forces between them, each being used to produce relative rotational movement between the rotor and the stator. It is also contemplated to make the construction shown in **Fig.7** so as to produce attraction forces between the magnets **54** and **56** on one side thereof and cooperating repulsion forces which add to the rotation generating forces produced on the opposite side.

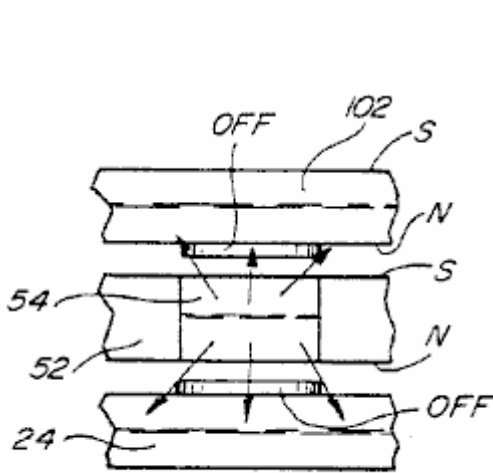

Fig. 8

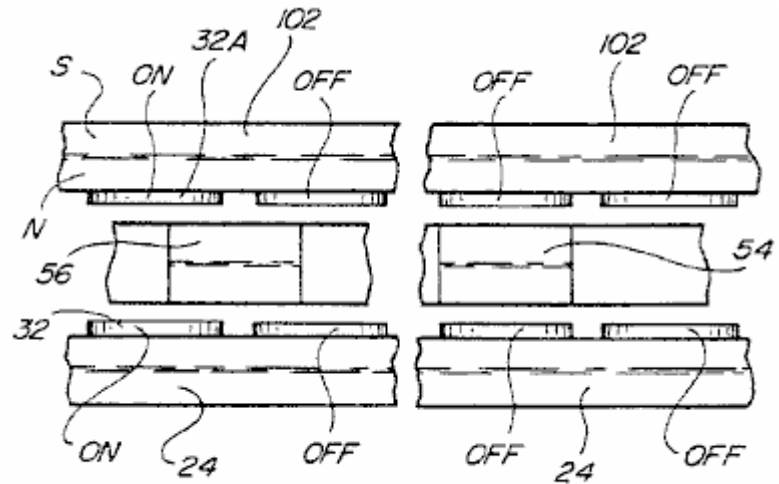

Fig. 9

Fig.8 and **Fig.9** are similar to **Fig.3** and **Fig.4** but show the relationship between the magnets **54** and **56** and the members **24** and **102** located on opposite sides. These figures show one form of interaction between the rotating magnets **54** and **56** and the stationary magnets **24** and **102** located as shown in **Fig.7**. In this construction, the device produces attractive rotating force only.

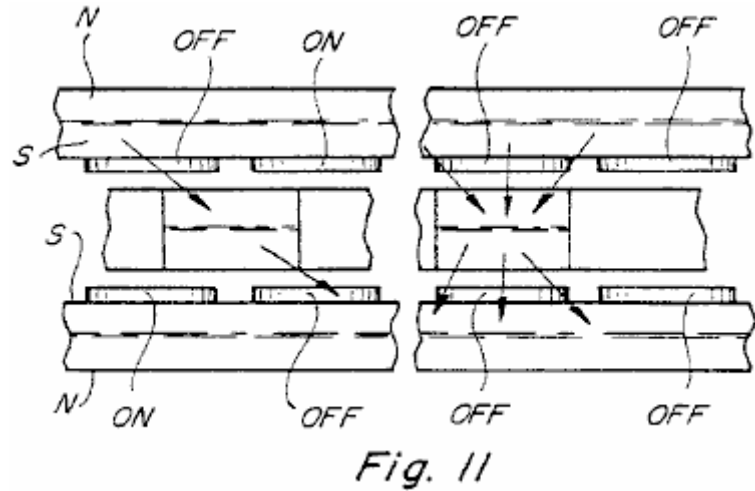
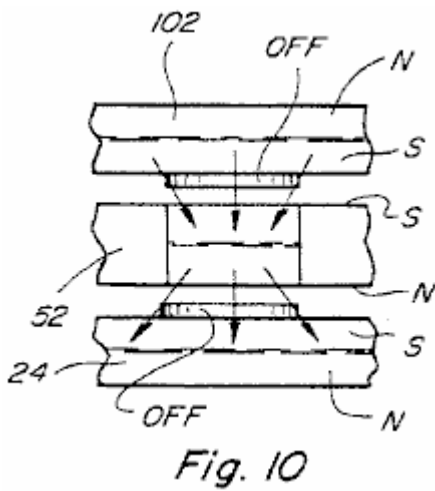

Fig.10 and **Fig.11** are similar to **Fig.8** and **Fig.9** except that in these figures both attraction and repulsion forces are shown being produced in association with the stationary magnets on opposite sides of the rotating magnets. Note also that the coils being energised on opposite sides of disc **52** are energised in a different arrangement.

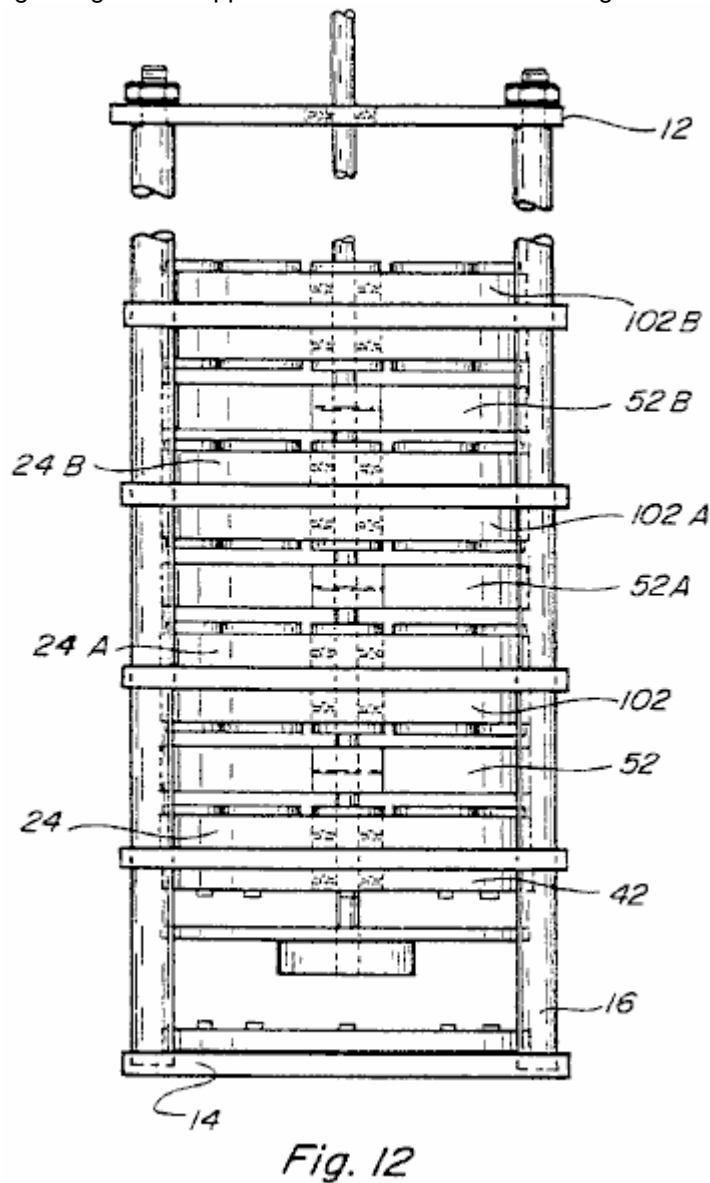

Fig.12 is a side view similar to **Fig.7** but showing the way in which several stationary and rotating magnetic members such as the discs **24** and **102** can be mounted on the same shaft, in almost any number of repeating groups to increase the amount of torque produced by the device. In **Fig.12**, the same power source and the same circuit arrangement can be used to energise the phototransistors and the infra red emitters. However, depending upon whether attraction or repulsion forces are used to produce the rotation or some combination of

them, will depend upon the order in which the coils associated with the stationary magnetic members are energised.

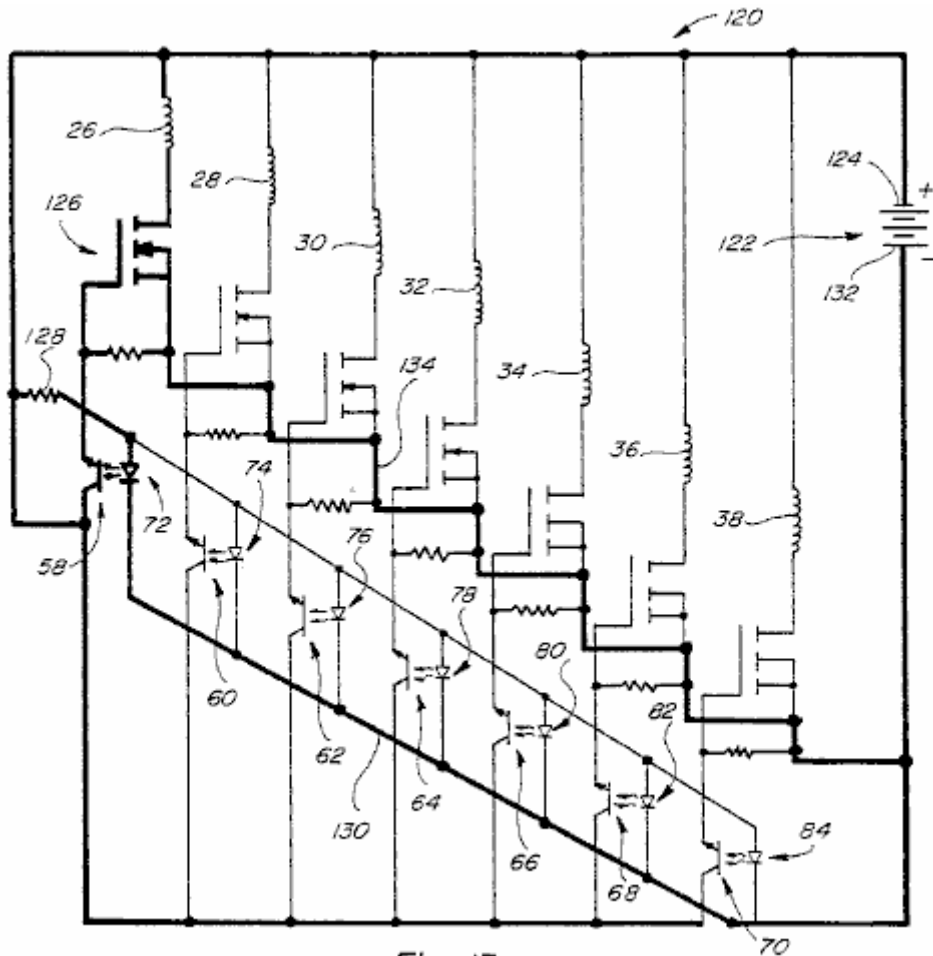

Fig. 13

Fig.13 is a circuit diagram for the device shown in **Fig.1** and **Fig.2**, showing the circuit connections for the coils **26-38** and for the circuit elements associated with them. A similar circuit can be used for the construction shown in **Fig.7** and **Fig.12**. The circuit also includes connections to the various phototransistors and infra red emitters.

In **Fig.13**, the circuit **120** is shown including a power supply **122** which may be a battery power supply, a rectified AC power supply or an AC or pulsed power supply. The positive side **124** of the power supply **122** is shown connected to one side of each of the coils **26-38**, coil **26** and the circuits associated with it being shown in bold outline and including connections to one side of a resistor **128** and to one side of the photo transistors **58-70**. The opposite side of the coil **26** is connected to one terminal of MOSFET **126**. The opposite side of the resistor **128** is connected to one side of the infra red emitter **72**, as well as to the corresponding sides of all of the other infra red emitters **74-84**. The opposite sides of the infra red emitters **72-84** are connected by lead **130** to the negative terminal side **132** of the power supply **122**. With the circuit as shown, the infra red emitters **72-84** are all continuously energised and produce light which can be detected by the respective phototransistors **58-70** when one of the openings **48** or **50** passes between them. When this happens, the respective phototransistor **58** will conduct and in so doing will apply positive voltage on the associated MOSFET **126**, turning the MOSFET on, and causing the voltage of the source **122** to also be applied across the coil **26**. The circuit for this is from the source **122** through the coil **26**, through the MOSFET **126** to and through the lead **134** to the opposite side of the source **122**. When the supply voltage is applied across the coil **26**, it operates to limit or prevent magnetic communication between whichever one of the magnets **54** or **56** happens to be positioned adjacent to the coil **26** which is in the space between that magnet **54** or **56** and the magnet **24**. This circuit is shown in bold in **Fig.13**. By properly timing and controlling the application of voltage to the various coils **26-38** in the manner described, the magnetic coupling between the magnets **54** and **56** and the magnet **24** can be accurately controlled and cause angular magnetic attraction between the magnet **54** (or **56**) and magnet **24**, which angular attraction (or repulsion) is in a direction to cause rotation of the rotating parts of the structure shown in **Figs. 1, 2, 7** and **12**. It should be understood that each of the coils **26-38** will be controlled in the same manner, that is, will have a voltage appearing across it at the proper time to control the direction of the magnetic coupling in a manner to produce rotation. The rotating portions will continue to rotate and the speed of rotation can be maintained at any desired speed. Various means can be used to control the speed of rotation such as by controlling the timing of

the DC or other voltage applied to the various coils, such as by using an alternating or pulsed current source instead of a direct current source or by loading the device to limit its rotational speed.

It is especially important to note that the energy required to operate the subject device is minimal since very little electrical energy is drawn when voltage is applied across the various coils when they are energised.

A well known equation used for conventional motor art, is:

$$\text{Power (in watts)} = \text{Speed} \times \text{Torque} / 9.55$$

Hence,

$$W = S \times T / 9.55$$

This equation has limited application to the present device because in the present device the torque is believed to be constant while the speed is the variable. The same equation can be rewritten:

$$T = 9.55 \times W / S \quad \text{or} \quad S = 9.55 \times W / T$$

These equations, if applicable, mean that as the speed increases, the watts divided by the torque must also increase but by a factor of 9.55. Thus if torque is constant or nearly constant, as speed increases, the power output must increase and at a very rapid rate.

It should be understood that the present device can be made to have any number of stationary and rotating magnets arranged in stacked relationship to increase the power output, (see **Fig.12**) and it is also possible to use any desired number of coils mounted on the various stationary magnets. In the constructions shown in **Figs. 1, 7, and 12** seven coils are shown mounted on each of the stationary magnets but more or fewer coils could be used on each of stationary magnet depending upon the power and other requirements of the device. If the number of coils is changed the number of light sources and photo-detectors or transistors will change accordingly. It is also important to note that the timing of the turning on of the various phototransistors is important. The timing should be such as that illustrated in **Fig.4**, for example, when one of the coils such as coil **32** is energised to prevent coupling in one direction between magnet **56** and magnet **24**, the adjacent coil **34** will not be energised. The reasons for this have already been explained.

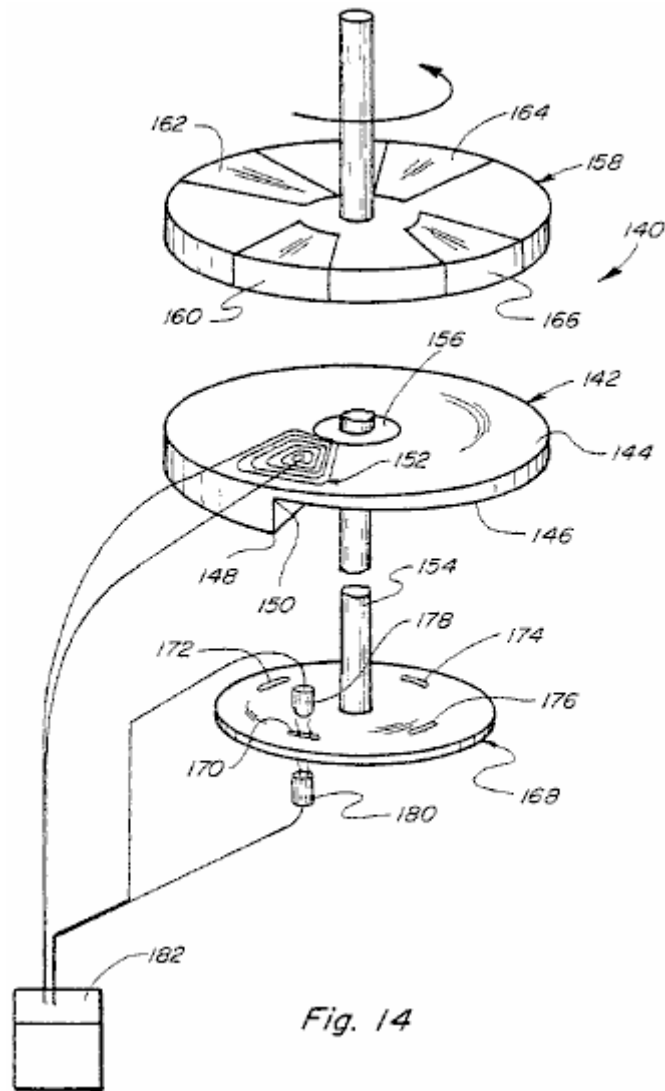

Fig. 14

Fig.14, shows another embodiment **140** of this motor. This includes a stationary permanent magnet **142** which has a flat upper surface **144** and a lower surface **146** that is circumferentially helical so that the member **142** varies in thickness from a location of maximum thickness at **148** to a location of minimum thickness at **150**. The thickness of the member **142** is shown varying uniformly. Near the location of the thickest portion **148** of the permanent magnet **142** and adjacent to the surface **144** is an air coil **152** shown formed by a plurality of windings. A shaft member **154** is journaled by the bearing **156** to allow rotation relative to the stationary permanent magnet **142** and is connected to a rotating disc **158**. The disc includes four spaced permanent magnets **160**, **162**, **164** and **166** mounted on or in it. The permanent magnets **160-166** are positioned to rotate close to the stationary permanent magnet **142** but with the coil **152** positioned between them. Coil **152** is connected into a circuit similar to that shown in **Fig.13** and so the circuit will not be described again.

The principals of operation of the device **140** shown in **Fig.14** are similar to those described above in connection with **Fig.1** and other figures. It is important to note, however, that the permanent magnets **160-166** rotate relative to the permanent magnet **142** because of the increasing coupling between them and the permanent magnet due to the increasing peripheral thickness of the permanent magnet. Thus the member **158** will rotate in a counter-clockwise direction as shown, and each time one of the magnets **160-166** moves into a position adjacent to the thickest portion **148** of the fixed permanent magnet **142** the coil **152** will have voltage applied across it, otherwise there would be a tendency for the member **158** to stop or reduce the rotational force. In order to overcome this the coil **152** is energised each time one of the permanent magnets **160-166** is in the position shown. The rotating disc **158** is connected through the shaft **154** to rotating disc **168** which has four openings **170**, **172**, **174** and **176** corresponding to the locations of the permanent magnets **160-166** so that each time one of the permanent magnets moves to a position adjacent to the thickest portion **148** of the stationary permanent magnet **142** the coil **152** will be energised and this will reduce or eliminate the coupling between the rotating and stationary magnets that would otherwise slow the rotating portions down.

The circuit connected to the coil **152** includes the same basic elements described above in connection with **Fig.13** including varying a photocell **178**, an infra red emitter **180** and a MOSFET **182** connected into a circuit such as

that shown in **Fig.13**. The timing of the energising of the coil **152** is important and should be such that the coil will be energised as the respective permanent magnets **160-166** move to a position in alignment or substantial alignment with the thickened portion **148** of the stationary permanent magnet **142**.

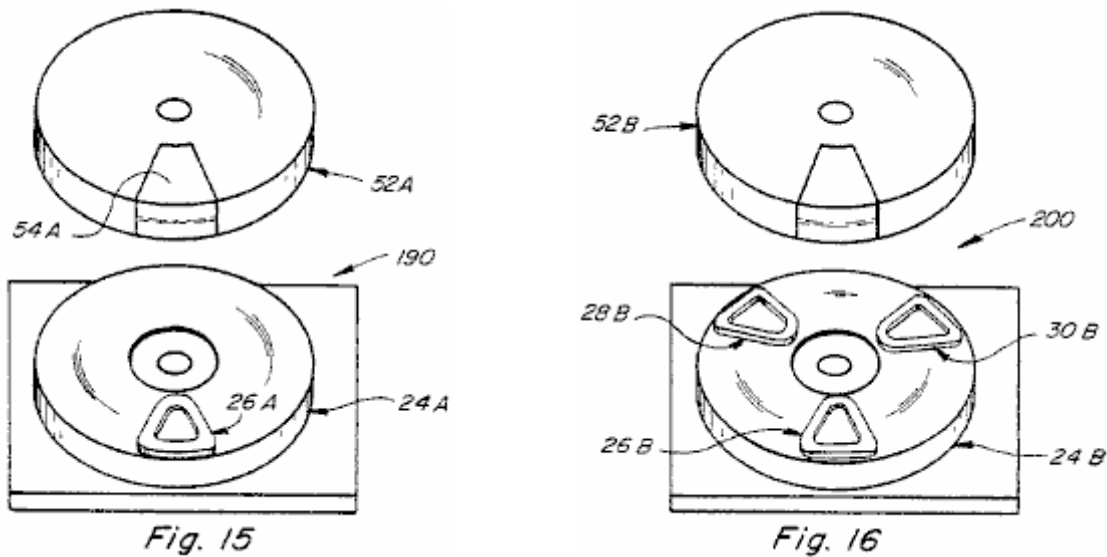

Fig.15 shows a basic simplified form **190** of the present device which includes a rotary member **52A** having a single permanent magnet portion **54A** mounted on it. The device also has a stationary permanent magnet **24A** with a single air coil **26A** positioned in the space between the members **52A** and **24A** in the manner already described. The construction **190** is not self-starting as are the preferred embodiments such as embodiment **10** but the rotary portions will rotate continuously once the device is started as by manually rotating the rotary portions. The construction **190** will have other portions as described above but the output from the construction will be less than the output produced by the other constructions.

Fig.16 shows another simplified version **200** of the device wherein the member **52B** is similar to the corresponding rotating member **52A** shown in **Fig.15**. However, the fixed structure including the permanent magnet **24B** has three windings **26B**, **28B** and **30B** located at spaced intervals adjacent to the upper surface of it. The construction shown in **Fig.16** will produce more output than the construction shown in **Fig.15** but less than that of the other constructions such as that shown in **Figs. 1, 2, 7** and **12**. Obviously, many other variations of the constructions shown in the application are also possible including constructions having more or fewer coils, more or fewer rotating magnetic portions, more or fewer rotating members such as disc **52** and more or fewer stationary members such as magnets **24** and **142**.

Figs.17-25 illustrate some of the underline principles of the present invention.

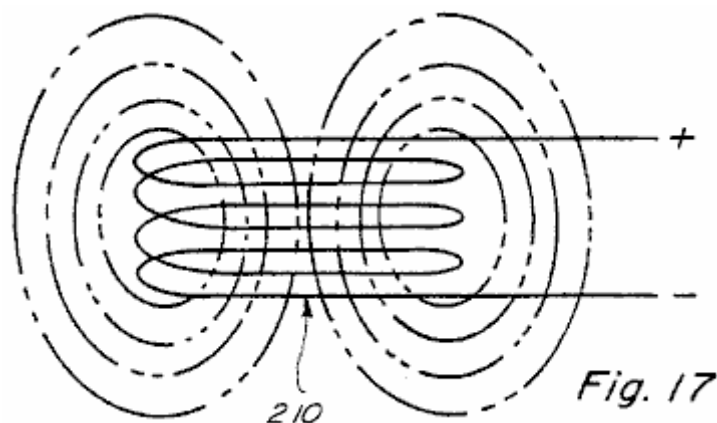

Fig.17 shows an air coil **210**, positioned in space, with an electric potential applied across it. With the energising voltage applied, the electro-magnetic field of air coil **210** extends substantially equally in the space above and below the coil as shown in dotted outlined.

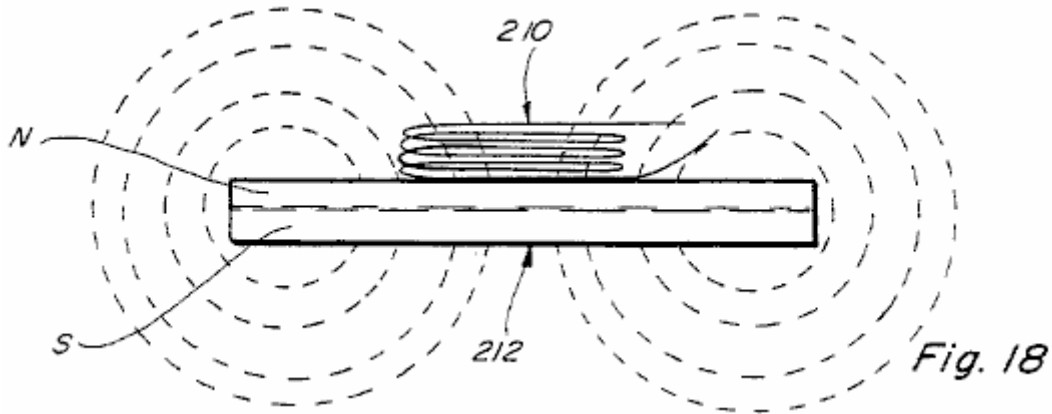

Fig.18 shows the air coil **210** positioned adjacent to one side (the north side) of permanent magnet **212**. In **Fig.18** no voltage is applied across the air coil **210** and therefore the coil does not produce an electro-magnetic field as in **Fig.17**. Under these circumstances, the air coil **210** has no effect on the magnetic field of the permanent magnet **212** and the field of the permanent magnet is substantially as shown by the dotted outlines in **Fig.18**.

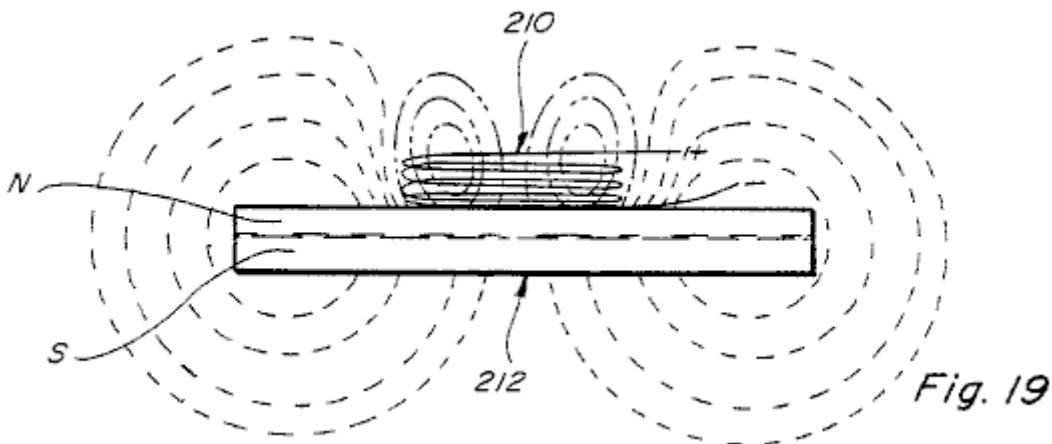

Fig.19 is similar to **Fig.18** except that in **Fig.19** the air coil **210** has an electric potential applied across it and therefore has an established electro-magnetic field shown again by dotted outline.

The electro-magnetic field of the air coil **210** modifies the magnetic field of the permanent magnet **212** in the manner shown. If coil **210** is placed in contact with, or close to the surface of, the permanent magnet and it is energised so that its polarity is opposite to that of the permanent magnet then the field produced is similar to that shown in **Fig.19**. Note that the field of coil **210** and the field of the permanent magnet **212** directly beneath the air coil **210** are in opposition and therefore act to cancel one another. Coil **210** would be defined to produce a counter-magnetomotive force which acts to cancel the field of the permanent magnet **212** in the region where the air coil **210** exists and the amount of the field in that region of the permanent magnet **212** that is cancelled is the remainder of the difference in magnetomotive force between the region of the permanent magnet **212** and the counter magnetomotive force of the air coil **210**. Note that, since the field of permanent magnet **212** is only altered in the region of the air coil **210**, the geometric magnetic field characteristics of the permanent magnet **212** can be altered selectively based upon the size of the coil **210**, the number of air coils **210** and the amount of counter magnetomotive force being produced by the air coil **210**.

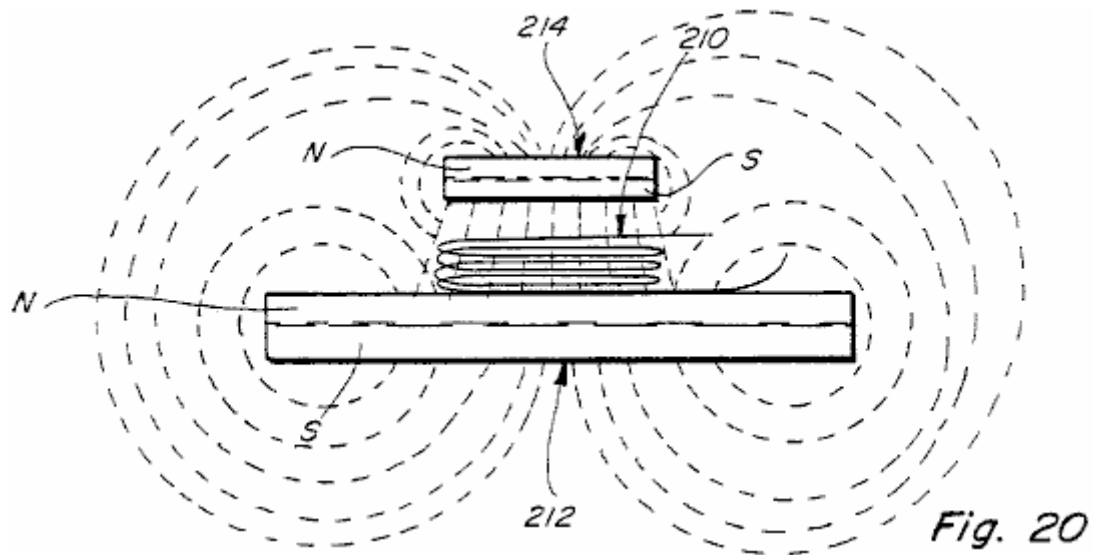

Fig.20 is similar to **Fig.19** except that a second permanent magnet **214** is positioned at a location spaced above the air coil **210**. In **Fig.20** no voltage is applied across the air coil **210** and therefore the air coil **210** does not have an electro-magnetic field. Thus **Fig.20** shows only the combined affect of the fields of the permanent magnets **212** and **214**. Since the permanent magnets **212** and **214** are positioned so that their respective north and south poles are close together, there will be a strong attractive force between them at the location of the air coil **210**.

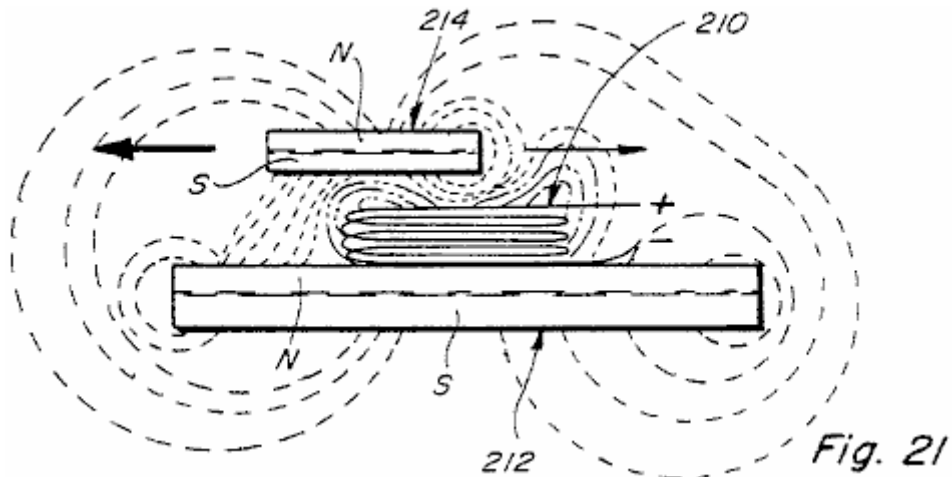

Fig.21 is a view similar **Fig.20** but with an electric potential applied across the air coil **210** and with the upper permanent magnet **214** displaced to the left relative to its position in **Fig.20**. Note that in **Fig.21** the shape of the electro-magnetic field of the air coil **210** is concentrated and shifted somewhat to the right and upward. This shift of the electro-magnetic field concentrates the magnetic coupling between the magnets **212** and **214** to the left thereby increasing the tendency of the upper permanent magnet **214** to move to the left. A much smaller magnetic coupling occurs between the right end of the permanent magnets **212** and **214** and thus the force tending to move the permanent magnet **214** to the right is much less than the force tending to move it to the left. This is illustrated by the size of the arrows shown in **Fig.21**.

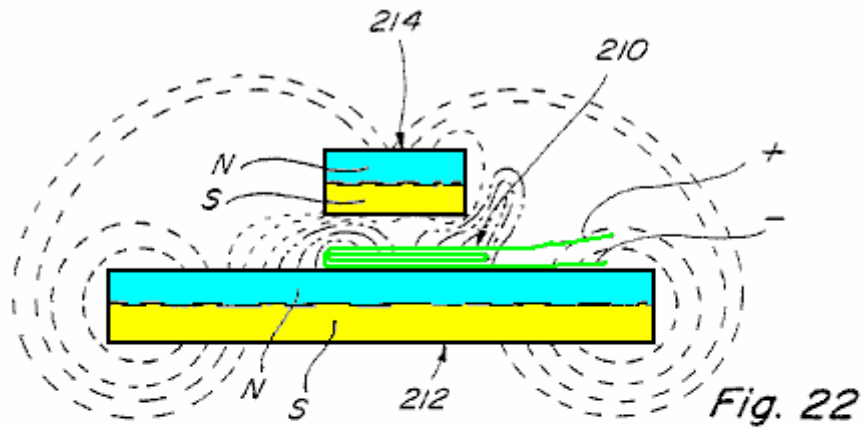

Fig. 22

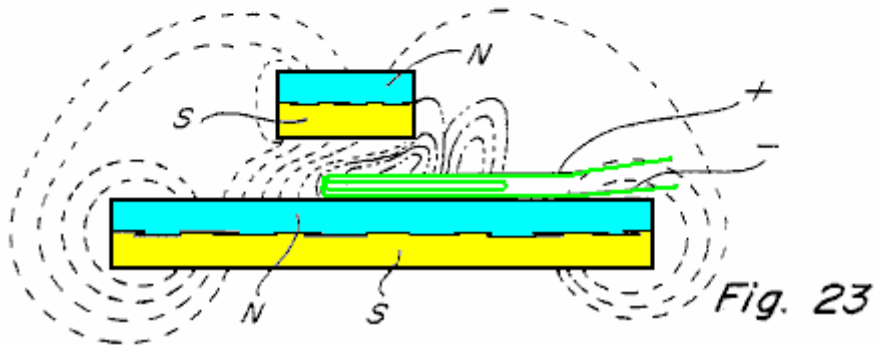

Fig. 23

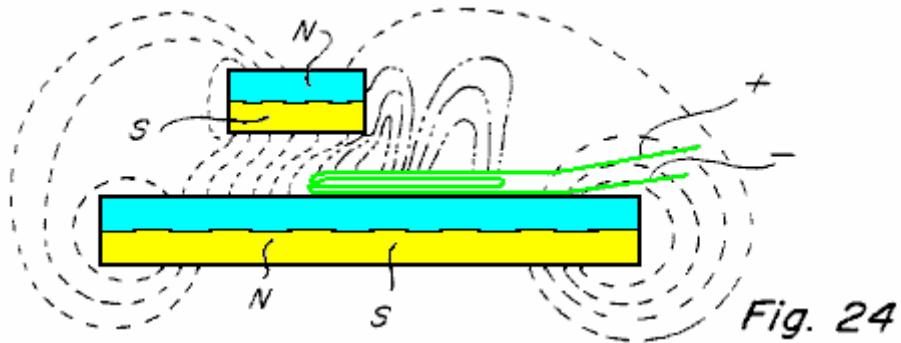

Fig. 24

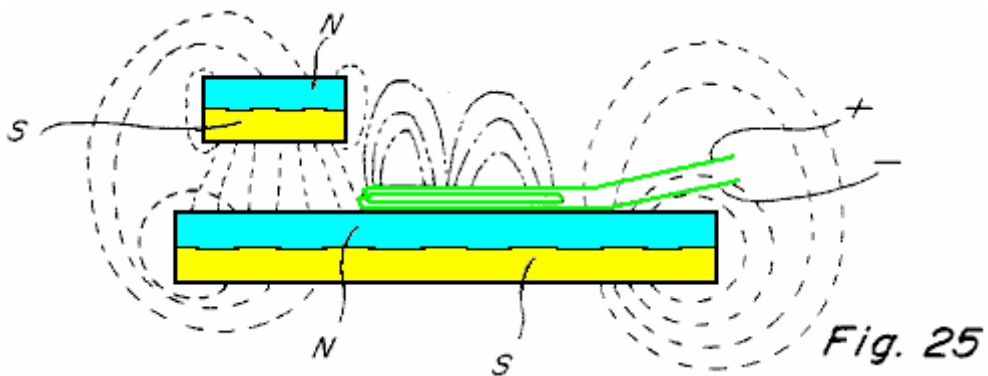

Fig. 25

Figs. 22-25 show four different positions of the upper permanent magnet **214** relative to the lower permanent magnet **212**. In **Fig.22** because of the position of the upper permanent magnet **214** relative to the air coil **210** there is a concentration of the magnetic coupling force tending to move the upper permanent magnet **214** to the left. This force increases in **Fig.23** and **Fig.24** until the upper permanent magnet **214** reaches the position shown in **Fig.25** where all of the magnetic coupling is directed substantially vertically between the permanent magnets **212** and **214** and in this position there is little or no torque as a result of coupling energy between the permanent magnets **212** and **214** tending to move them relative to one another.

The principles illustrated in **Figs. 17-25** are at the heart of the present invention and explain where the energy comes from to produce relative movement between the permanent magnets.

The present device has application for very many different purposes and applications including almost any purpose where a motor or engine drive is required and where the amount of energy available and/or required to produce the driving force may vary little to nil. Applicant has produced devices of the type described herein capable of rotating at very high speed in the order of magnitude of 20,000 RPMs and with substantial torque. Other lesser speeds can also be produced, and the subject device can be made to be self starting as is true of the constructions shown in **Figs. 1, 2, 7 and 12**. Because of the low power required to operate the device applicant has been able to operate same using a commercially available battery such as a nine volt battery.

CLAIMS

1. A device to control the magnetic interaction between spaced permanent magnets comprising:
 - a first permanent magnet having opposite surfaces with north and south poles respectively,
 - a second permanent magnet spaced from and movable relative to the first permanent magnet and having opposite surfaces with north and south poles respectively, one of which is positioned in close enough proximity to one of the surfaces of the first permanent magnet to produce magnetic interaction between them,
 - a coil of conductive metal positioned in the space between the first and second permanent magnets,
 - a source of electrical energy and switch means connected in series therewith across the coil whereby when the switch means are closed the electrical energy from said source is applied across the coil whereby the magnetic interaction between the first and second permanent magnets is changed, and
 - means to control the opening and closing of the switch means.

2. A device for producing rotational movement and torque comprising:
 - a member journaled for rotational movement about an axis of rotation, the rotating member having at least a portion adjacent the periphery thereof formed of a permanently magnetized material,
 - a stationary member formed of permanently magnetized material mounted adjacent to the peripheral portion of the rotating member axially spaced from it whereby a magnetic interaction is produced between the stationary and the rotating members in predetermined positions of the rotating member,
 - at least one coil positioned extending into the space between the stationary and rotating members,
 - means including a source of electric potential and switch means connected in series across the coil, and
 - means to predeterminately control the opening and closing of the switch means during rotation of the rotating member to vary the magnetic interaction in a way to produce rotation of the rotating member.

3. Means to predeterminately vary the magnetic interaction between first and second spaced permanent magnet members comprising a first permanent magnet member having north and south poles, a second permanent magnet member having north and south poles spaced from the first permanent magnet member by a gap between them, a coil positioned extending into the gap between the first and second permanent magnet members, means connecting the coil across a circuit that includes a source of voltage and switch means connected in series therewith so that when the voltage source is connected across the coil it effects the magnetic interaction between the first and second permanent magnet members, and means for mounting the first permanent magnet member for movement relative to the second permanent magnet member and relative to the coil in the gap between them.

4. The device of claim 3 wherein the first and second permanent magnet members are mounted to produce magnetic attraction between them.

5. The device of claim 3 wherein the first and second permanent magnet members are mounted to produce magnetic repulsion between them.

6. The device of claim 3 wherein the means mounting the first permanent magnet member includes means mounting the first permanent magnet member for rotational movement relative to the second permanent magnet member and the switch means includes cooperative optical means having a first portion mounted for

movement with the first permanent magnet member and a second portion associated with the second permanent magnet member.

7. The device of claim 6 wherein the switch means includes a light source and a light sensitive member associated respectively with the first and second permanent magnet members, and control means for them mounted for movement with the first permanent magnet.

8. The device of claim 3 wherein the second permanent magnet member is an annular permanent magnet member having one of its poles on one side of the gap and the other of its poles opposite thereto, means mounting the first permanent magnet member for rotational movement relative to the second permanent magnet member, said first permanent magnet member having one of its poles on one side of the gap, and a plurality of circumferentially spaced coils mounted in the gap between the first and second permanent magnet members.

9. The device of claim 8 wherein the first permanent magnet member includes two circumferentially spaced portions.

10. Means for producing rotational movement comprising:

a support structure having a first permanent magnet mounted thereon, said first permanent magnet having a north pole adjacent one surface and a south pole adjacent to the opposite surface,

means for mounting a second permanent magnet for rotational movement in a plane parallel to the first permanent magnet, the second permanent magnet occupying an curved portion of said mounting means less than the entire circumference of said mounting means and having a north pole adjacent to the opposite surface and positioned so that there is a magnetic interaction between the spaced first and second permanent magnets across a gap between them in at least one position thereof,

at least one air coil positioned in the gap between the first and second permanent magnets,

a source of electric potential and switch means for controlling the application of the electric potential from said source across the air coil, the application of voltage across the air coil effecting the magnetic interaction between the first and second permanent magnet members in certain positions of the second permanent magnet relative to the first permanent magnet and in such a manner as to produce rotational movement of the second permanent magnet.

11. The device for producing rotational movement of claim 10 wherein a third permanent magnet is mounted on the support structure on the opposite side of the second permanent magnet from the first permanent magnet so as to establish a second gap between them and so that there is magnetic interaction between the second and third permanent magnets, and at least one second coil mounted in the gap between the second and third permanent magnets to predeterminately effect the magnetic interaction between them in certain positions of the second permanent magnet relative to the third permanent magnet thereby to contribute to the production of rotational movement of the second permanent magnet member relative to the first and third permanent magnets.

12. The device for producing rotational movement defined in claim 11 wherein the switch means for applying voltage from the source across the coils includes a light source and light sensor one mounted on the support structure and the other on the rotating means to produce a switching action to apply and remove voltage from across the coils in predetermined positions of the second permanent magnet relative to the first and third permanent magnets.

13. Means for producing rotary motion using magnetic energy from permanent magnets comprising:

a fixed permanent magnet having opposite surfaces with north and south poles respectively adjacent thereto,

a shaft having an axis and means journaling the shaft for rotation in a position extending normal to the opposite surfaces of the fixed permanent magnet,

a movable permanent magnet and means mounting the movable permanent magnet on the shaft for rotation therewith, the movable permanent magnet occupying an curved portion of said mounting means less than the entire circumference of said mounting means and having opposite surfaces with associated north and south poles respectively, one pole of said movable permanent magnet being positioned to move in close

enough proximity to one of the opposite surfaces of the fixed permanent magnet to produce magnetic interaction between them,

at least one coil mounted in the space between the fixed permanent magnet and the movable permanent magnet, energising of the coil effecting the magnetic interaction between the fixed and the movable permanent magnets when positioned between them, and

means connecting the coil to a source of energising potential in selected positions of the movable permanent magnet relative to the fixed permanent magnet.

14. The device for producing rotary motion of claim 13 wherein a plurality of coils are mounted in a coplanar relationship in the space between the fixed permanent magnet and the movable permanent magnet, the means connecting the coils to a source of energising potential including means for energising the respective coils in a predetermined sequence.
15. The device for producing rotary motion of claim 13 including a second movable permanent magnet mounted on the means mounting the movable permanent magnet for movement therewith, said second movable permanent magnet being spaced circumferentially from the aforesaid movable permanent magnet.
16. The device for producing rotary motion of claim 13 wherein a second fixed permanent magnet has opposite surfaces with north and south poles respectively adjacent thereto and is mounted on the opposite side of the movable permanent magnet from the aforesaid fixed permanent magnet and at least one coil mounted in the space between the second fixed permanent magnet, and the movable permanent magnet.
17. A device for producing rotary motion defined in claim 13 wherein the means connecting the coil to a source of energising potential includes a fixed light source and a fixed light sensitive member mounted in spaced relationship and means on the mounting means for the movable permanent magnet for predeterminedly controlling communication between the light source and the light sensitive member during rotation of the movable permanent magnet.
18. A magnetic motor-like device comprising:
 - a fixed support structure having a permanent magnet member mounted thereon, said member having opposite side faces with a north magnetic pole adjacent one side face and a south magnetic pole adjacent the opposite side face,
 - a plurality of coils mounted adjacent to and arranged about one of the opposite side faces,
 - an orifice through the permanent magnet member at a location intermediate the coils,
 - a shaft extending through the orifice for rotation about the axis thereof,
 - a member attached to the shaft for rotation therewith and spaced from the one opposite magnet side faces,
 - at least one magnet member attached to a segment of said rotating member for rotation therewith, each of said rotating magnetic members having a magnetic pole face positioned in spaced relation to the one opposite pole side face of the fixed permanent magnet member, the plurality of coils being in the space formed by and between the fixed permanent magnet member and the at least one rotating magnet member, and
 - means to selectively and sequentially energise the coils as the shaft rotates to predeterminedly control the magnetic interaction between the at least one magnetic member and that fixed permanent magnet member.
19. The magnetic device of claim 18 wherein there is an odd number of coils mounted in the space between the permanent magnet member and the at least one rotating magnetic member.
20. The magnetic device of claim 18 wherein the at least one magnetic member attached to the rotating member for rotation therewith includes two circumferentially spaced rotating magnet portions.
21. A device for producing rotary motion comprising:
 - a support structure having a wall member,

a shaft and means journaling the shaft for rotation in the wall member about its axis,

a permanent magnet member mounted on the wall member extending about at least a portion of the shaft, said permanent magnet member having one pole adjacent to the wall member and an opposite pole spaced therefrom,

a member mounted on the shaft having at least two magnetic members oriented to produce magnetic interaction with the permanent magnet member,

a plurality of coils mounted in coplanar relation extending into the space formed by and between the permanent magnet member and the at least two magnetic members and

means to sequentially apply a voltage across the respective coils to vary the magnetic interaction between the permanent magnet member mounted on the wall member and selected ones of the at least two magnetic members.

22. A device for producing rotary motion using magnetic energy from permanent magnets comprising

a fixed permanent magnet having opposite surfaces with north and south poles respectively adjacent thereto,

a shaft and means for journaling the shaft for rotation extending normal to the opposite surfaces of the fixed permanent magnet,

at least two rotatable permanent magnets and means mounting them for rotation with the shaft, the rotatable permanent magnets having opposite surfaces with associated north and south poles respectively, one pole of each rotatable permanent magnet being positioned close enough to one of the opposite surfaces of the fixed permanent magnet to produce magnetic interaction therebetween,

a plurality of spaced coils arranged to be coplanar and positioned in the space formed by and between the fixed permanent magnet and the rotatable permanent magnets, and

means to apply a voltage across respective ones of the coils in a sequence so as to predeterminately affect the interaction between the fixed permanent magnet and the rotatable permanent magnets in a manner to produce rotation of the at least two permanent magnets.

23. A device for producing rotary motion using magnetic energy from permanent magnets comprising:

a fixed annular permanent magnet having a flat surface on one side and an opposite surface of helical shape extending therearound from a location of minimum thickness to a location of maximum thickness approximately adjacent thereto, the annular permanent magnet having one of its poles adjacent to the flat surface and its opposite pole adjacent to the helical opposite surface,

a shaft and means for journaling the shaft for rotation extending substantially normal to the flat surface of the fixed permanent magnet,

a permanent magnet and means mounting it on the shaft for rotation therewith, said permanent magnet having opposite pole faces and being positioned so that there is magnetic interaction between said permanent magnet and the fixed annular permanent magnet,

at least one air coil positioned in the space between the fixed and rotatable permanent magnets, and

means to apply a voltage across the air coil when the rotatable permanent magnet is adjacent to the thickest portion of the fixed permanent magnet to change the magnetic interaction therebetween, said last name means including a source of voltage and switch means in series with the source for controlling the application of voltage across the air coil.

24. The device for producing rotary motion of claim 23 wherein a plurality of rotatable permanent magnets are mounted at circumferentially spaced locations about the shaft for magnetic interaction with the fixed annular permanent magnet, the switch means controlling the application of voltage from the source to the air coil

when one of the rotatable permanent magnets is positioned adjacent to the thickest portion of the fixed annular permanent magnet.

- 25.** The means for producing rotary motion of claim 23 wherein the switch means includes cooperative optical means having a first portion associated with the fixed annular permanent magnet and a second portion associated with the rotatable annular permanent magnet.

The Power Plant of Claude Mead and William Holmes

US Patent 4,229,661

21st October 1980

Inventors: Claude Mead and William Holmes

POWER PLANT FOR CAMPING TRAILER

Note: This patent is not a free-energy patent, but it does provide a suggestion for an integrated and practical system for providing power for people living in a caravan which is frequently off-grid but which occasionally is positioned where electrical mains power is available. It describes a practical system for storing wind energy for high-power electrical power supply, and so is of interest.

ABSTRACT

A power plant for mobile homes, camping trailers, and the like, capable of capturing low-powered wind energy, storing the energy in the form of compressed air, and delivering it on demand in the form of household electrical current. The device comprises a wind turbine which drives an air compressor which feeds a storage tank. When required, the compressed air drives a turbine coupled to an electrical generator. Various pressure regulators are used to control the speed of the generator. The wind turbine is also coupled to an alternator which keeps a bank of batteries charged. A DC motor running on the batteries, is used when necessary, to boost the drive of the air compressor during periods of heavy or long power drain. Provision is made for rapidly recharging the power plant from either a supply of compressed air or from an AC power source.

US Patent References:

2230526	Wind power plant	February, 1941	Claytor	290/44
2539862	Air-driven turbine power plant	January, 1951	Rushing	290/44
3315085	Auxiliary power supply for aircraft	April, 1967	Mileti et al.	290/55
3546474	Electrohydraulic Transmission of Power	December, 1979	DeCourcy et al.	290/1
4150300	Electrical and thermal system for buildings	April, 1979	VanWinkle	290/55

BACKGROUND OF THE INVENTION

The current shortage of fossil fuel and public concern for the quality of the environment have triggered a hurried search for alternate forms of energy. The capture and use of solar energy, and its derivative, wind power, is the object of many new inventions. Due to the inefficiency of the collector device and storage media, use of these forms of energy has been limited to low-power stationery applications. Yet wind power should be adequate for any application requiring very low power or a short, occasional low to medium power supply of energy. These circumstances are encountered, for instance, in a refrigerated railroad car where occasional bursts of power are required to run the refrigerating system in order to maintain a low temperature inside the car. Similar circumstances are found in some mobile housing units such as a camping trailer. There, again, a supply of household current might be necessary for a short time between long periods of travel. In such instances, a system can be devised for accumulating energy generated by a wind turbine powered by the wind or by the air draft created by the motion of the vehicle. It is further desirable that the power system be capable of being replenished from non-polluting energy sources which can be encountered along the travel route.

SUMMARY OF THE INVENTION

It is accordingly an object of the instant invention to provide a novel power plant for mobile homes, and the like, which captures wind energy, stores it in the form of compressed air, and delivers it on demand in the form of household electrical current.

Another object of this invention is to provide a power plant which does not discharge polluting effluents into the atmosphere.

Still another object of the invention is to provide a power plant which can be recharged by capturing the effect of the wind, or the effect of the air stream created by the movement of the vehicle.

A further object of the invention is to provide a power plant which can be recharged from a household current electrical outlet.

It is also an object of this invention to provide a power plant which can be replenished from a source of compressed air such as those found in automotive service stations.

An additional object of the invention is to provide a power plant which is responsive to a very low level of wind energy for a short period of time.

These and other objects are achieved by a power plant which comprises a wind turbine driving an air compressor. The air supply of the compressor is stored in the tank and used on demand to activate a turbine. The turbine, in turn, is coupled to a generator which creates household current. The wind turbine is also coupled to generators which charge a series of electrical batteries. On occasions when the AC power drain requires it, a motor running on the batteries is used to boost the output of the air compressor. Provision is made for driving the compressor from an outside AC power source. The air tank has a separate inlet through which it can be replenished from a source of compressed air.

THE DRAWINGS

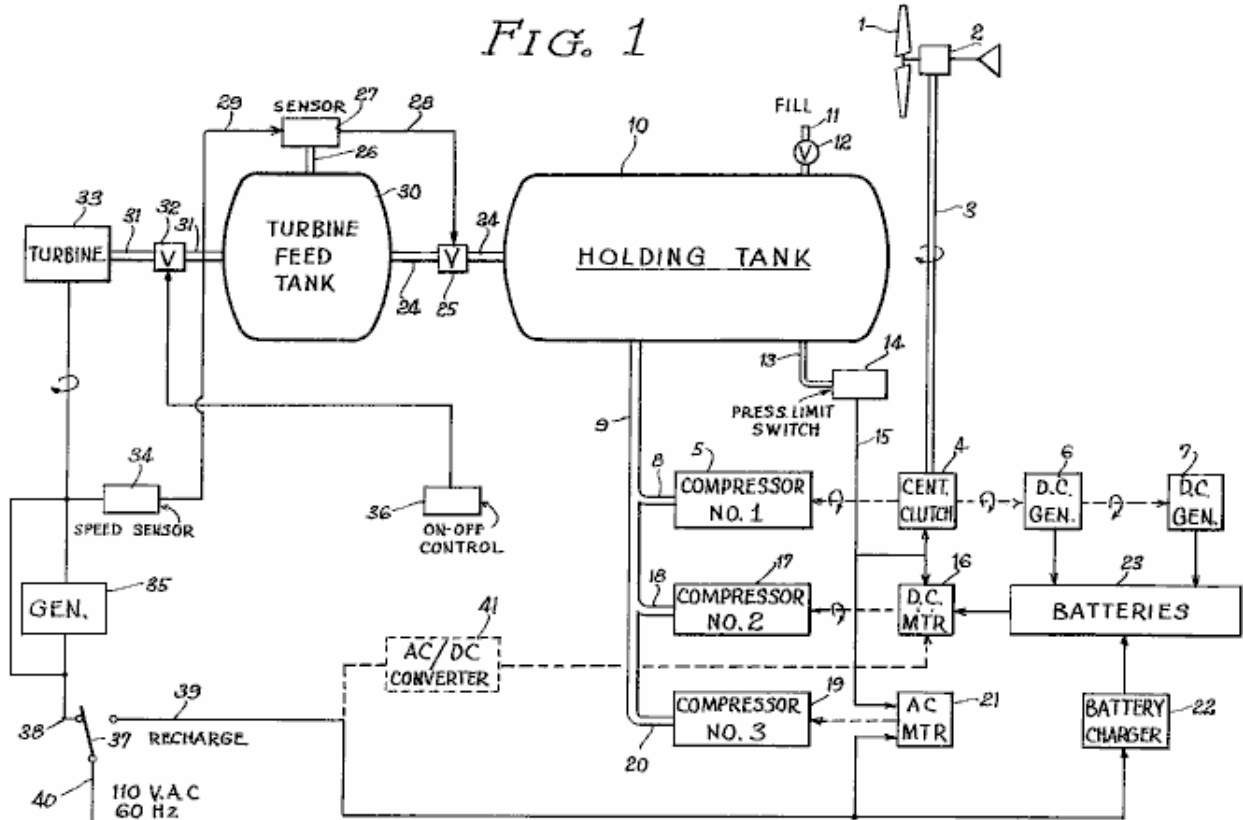

Fig.1 is the general block diagram of the entire power plant;

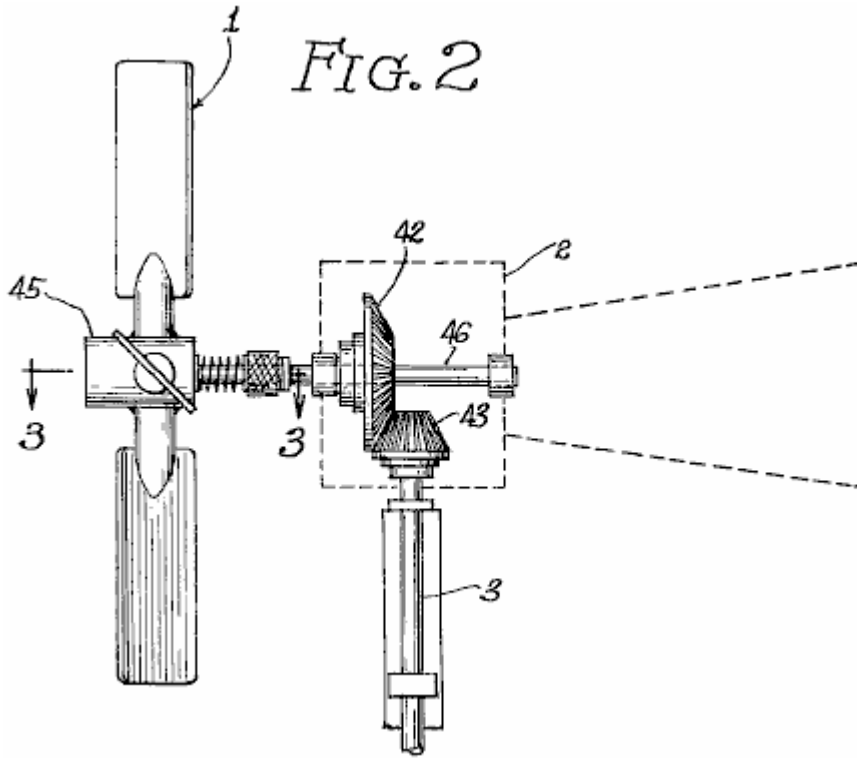

Fig.2 is a front elevation of the wind turbine and of its mechanical coupling to the drive shaft;

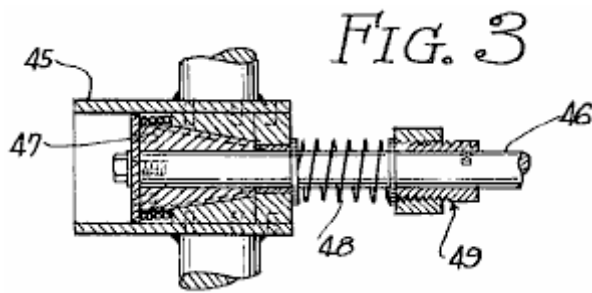

Fig.3 is a cross-sectional view taken along line 3-3 of Fig.2 showing the propeller linkage mechanism in the engaged position;

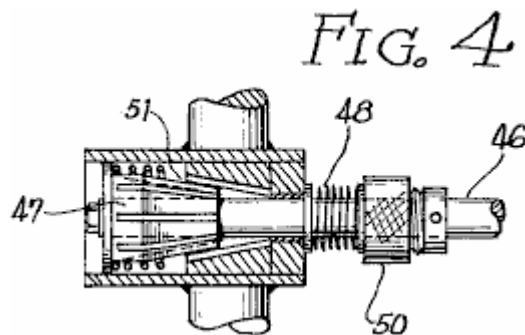
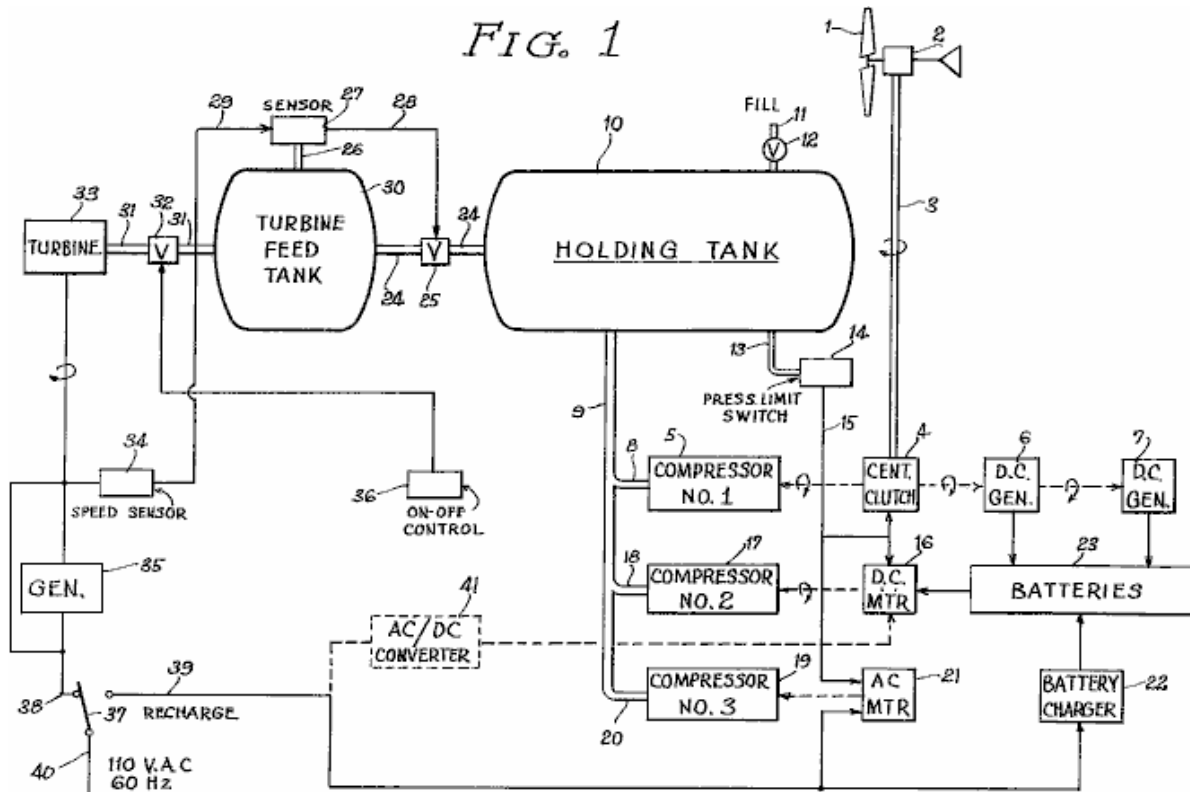

Fig.4 is a view similar to the one illustrated in Fig.3 but showing the propeller linkage mechanism in the disengaged position.

DESCRIPTION OF THE PREFERRED EMBODIMENT OF THE INVENTION



Referring now to **Fig.1**, there is shown a diagrammatic representation of the preferred embodiment of the invention. A wind turbine comprising a propeller **1** and an orthogonal coupling assembly **2** drives a shaft **3** connected to a centrifugal clutch **4**. This type of clutch is designed to engage itself when the speed of the drive shaft **3** reaches a certain minimum preset limit. The plate of the clutch is first connected to a compressor **5** and second to two DC generators **6** and **7**. Block **5** represents a adiabatic compressor requiring an input drive of approximately one-fourth horsepower.

The output of the compressors **5** is protected by a check valve and leads into a pipe **8** connected to a tank inlet pipe **9**. The inlet pipe **9** feeds into a holding tank **10** capable of holding sixty gallons of compressed air under a maximum pressure of 200 pounds per square inch. The DC generators **6** and **7** supply a series of electrical batteries **23**. The batteries feed a DC motor **16**. The DC motor is in turn connected to a second compressor **17**. The second compressor **17** is similar to the first compressor **5** and is connected through to pipe **18** to the tank inlet pipe **9**. A third compressor **19** similar to the first and second compressors is also connected to the tank inlet pipe **9** through pipe **20**. The third compressor **19** is powered by an AC motor **21**.

A pressure limit switch assembly **14** senses the pressure in the holding tank through a pipe **13**. A high pressure switch within the assembly **14** is activated when the holding tank reaches the maximum safely allowable pressure. This switch through line **15** causes the disengagement of the clutch **4** and turns off DC motor **16** and AC motor **21**. A second switch within the assembly **14** is activated when the holding pressure falls below a preset limit.

This second switch through line **15** turns on the DC motor **16**. It can now be seen that when the tank pressure is below the lowest limit, both the first and second compressors **15**, **17** will be activated. When the tank pressure goes above the lowest preset limit, only the first compressor **5** will be activated. If the holding tank pressure reaches the maximum tolerable limit all the compressors will be deactivated. The engagement speed of the centrifugal clutch **4** is set to a level corresponding to the minimum power necessary to drive the first compressor **5** and the DC generators **6** and **7**. If the speed of the wind falls below that level, the shaft **3** will be free-running.

The holding tank **10** has a separate inlet **11** protected by a check valve **12**. The holding tank is connected to a turbine feed tank **30** through pipe **24** controlled by valve **25**. The turbine feed tank **30** is connected to the inlet of a turbine **33** through pipe **31** controlled by valve **32**. The turbine **33** is powered by the expansion of the compressed air supplied by the turbine feed tank **30**. The turbine **33** is similar to the compressed air motors used in certain

impactors and drills. The turbine drives an AC generator **35** designed to supply approximately five kilowatts of household current at 60 Hz and 110 volts. The turbine is turned on by means of the valve **32** controlled by an/off switch **36**. The speed of the turbine **33** is determined by the pressure of the air accumulated in the turbine tank **30**. The pressure is monitored by sensor **27** connected to the turbine feed tank **30** by pipe **26**. Sensor **27** contains a set of high and low limits. When the turbine feed tank pressure falls below the low limit, valve **25** is opened through control line **28**. When the pressure in the turbine feed tank **30** reaches the high limit, the valve **25** is closed. The high and low limit of sensors **27** are not fixed but subject to minor variations in response to the speed of the turbine **33**.

The speed of the turbine **33** and of the generator **35** is monitored by speed sensor **34**. The output of the speed sensor **34** is inversely proportional to the speed of the turbine **33**. The speed sensor signal **29** is fed to sensor **27**. If the output frequency of the generator **35** deviates from the required 60 Hz, the high and low limits of the sensor **27** are either increased or decreased. If the speed of the generator is slowed down by an increase in the load current, the high and low limits of sensor **27** are raised in order to raise the pressure in turbine feed tank **30**. The turbine **33** will respond to the pressure change by increasing its rotational speed. The output of the generator **35** is made available for use through lines **38** and **40** controlled by a switch **37**.

The pressure in the holding tank **10** may be boosted from two external sources. First, compressed air may be introduced through inlet **11**. Second, the AC motor **21** may be connected to an external source of electrical energy through lines **39** and **40** controlled by switch **37**. The external electrical source may also be applied to a battery charger **22** which supplies the series of batteries **23**. In an alternate version of the preferred embodiment, it is suggested that an AC/DC converter **41** be used to drive the DC motor **16** from the external electrical supply. In such a case, the AC motor **23** and the third compressor **19** are not necessary.

The power plant just described is primarily designed to be installed on board a camping trailer. This power plant will accumulate wind ("aeolian") energy during the periods when the wind is blowing or the trailer is in motion. The energy is stored in two forms. First, it is stored in the form of compressed air in the holding tank **10**. Second, it is stored in the form of DC current in the series of batteries **23**. Both storage media are ecologically clean. Furthermore, the electrical system can boost the power of the compressed air system during periods of heavy power drain or long use. For added convenience, the system can be refueled from an external source of electrical energy such as a household outlet or from an external source of compressed air such as those found in service stations for use by vehicle drivers. It should be noted also that this power plant is versatile in that it can be driven not only from the movement of fluids such as air or water, but also from the movement of the vehicle. In the later case, the shaft **3** would be coupled directly to the wheel of the vehicle.

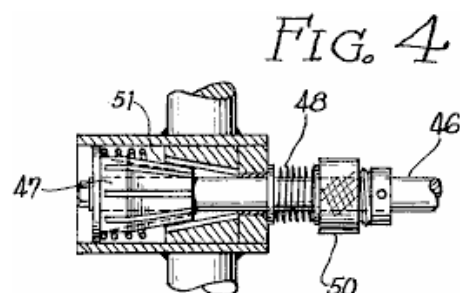
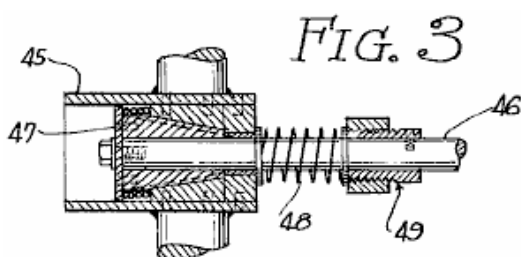
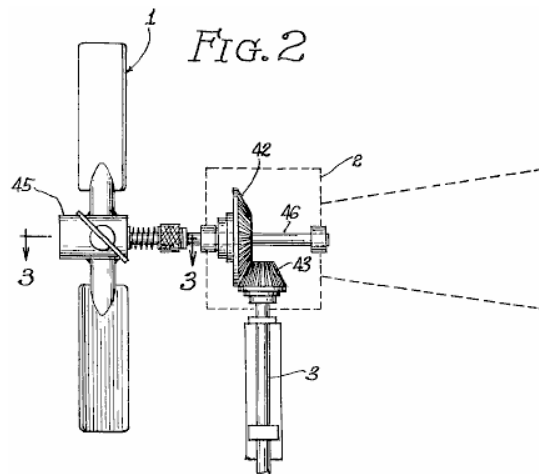

Referring now to **Figs. 2** through **4**, there is shown the details of the propeller **1** and coupling box **2**. The propeller is noticeable by the fact that it is protected against bursts of wind which could damage the equipment. The hub **45** of propeller **1** is mounted on a shaft **46** by means of a conical spindle **46**. The hub has a central cavity **51** matching the outline of the spindle **47**. The hub **45** is held against the spindle by means of a coil spring **48** resting against an adjustable stop **49**. An excess of pressure of the wind against the propeller **1** will cause the hub **45** to be pulled back against the spring **48**, disengaging it from the spindle **47**. At that point the propeller **1** will rotate freely without driving the shaft **46**. The pressure of the coil spring **48** may be adjusted by turning the ring **50** around the threaded base of the stop **49**.

The various mechanical and electro-mechanical components of the power plant such as the centrifugal clutch, compressors, generators, turbines, valves and pressure-activated switches are well known to those skilled in the art.

The speed sensor **34** may be implemented with an electronic integrator whose output signal **29** amplitude is proportional to the frequency of AC generator **35**. The signal **29** is then used to modulate the sensitivity of sensor switches **27**. This technique is also well known to those skilled in the electro-mechanical arts.

Modifications, other than those suggested, can be made to the embodiment of the invention just described without departing from the spirit of the invention and the scope of the appended claims.

CLAIMS

1. A power plant which comprises:

- (a) first rotating means responsive to movement of a fluid;
- (b) first fluid compressor driven by the first rotating means;
- (c) first means for coupling the first rotating means to the first fluid compressor;
- (d) first electrical energy generator driven by the first rotating means;
- (e) second means for coupling the first rotating means to the first generator;
- (f) means for accumulating electrical energy generated by the first generator;
- (g) second rotating means responsive to The accumulated energy;
- (h) second fluid compressor driven by the second rotating means;
- (i) means for storing compressed fluid;
- (j) fluid conduit means for connecting the outputs of the first and second fluid compressors to the means for storing;
- (k) means responsive to fluid pressure within the means for storing for controlling the operation of the first and second fluid compressors;
- (l) third rotating means responsive to the expansion of compressed fluid;
- (m) means for connecting the means for storing to the third rotating means;
- (n) second electrical energy generator driven by third rotating means; and
- (o) means for coupling the third rotating means to the second electrical energy generator.

2. The power plant claimed in claim 1 wherein the means for controlling the operation of the first and second fluid compressors comprise:

- (a) first switch means responsive to high pressure for turning off the second rotating means and for inhibiting the first fluid compressor; and
- (b) second switch means responsive to lower pressure for turning on the second rotating means.

3. The power plant claimed in claim 2 wherein the means for storing compressed fluid comprise:

- (a) a high pressure tank;
- (b) a low pressure tank;
- (c) first valve means responsive to fluid pressure in the low pressure tank for regulating the flow of fluid from the high pressure tank to the low pressure tank; and
- (d) the means for connecting the means for storing to the third rotating means comprise fluid conduit means and second valve means for controlling the flow of fluid.

4. The power plant claimed in claim 3 wherein The means for storing further comprise means responsive to the rotating speed of the third rotating means for controlling the first valve means.

5. The power plant claimed in claim 4 which further comprises:

- (a) fourth rotating means responsive to electrical energy;
 - (b) third fluid compressor driven by the fourth rotating means;
 - (c) means for coupling the fourth rotating means to the third fluid compressor;
 - (d) means for connecting the third fluid compressor to the means for storing; and
 - (e) means for connecting the fourth rotating means to an external electrical energy source.
6. The power plant claimed in claim 4 wherein The means for accumulating comprise at least one electrical storage battery;
- a battery charger connected to The battery; and
means for connecting The battery to an external electrical power source.
7. The power plant claimed in claim 1 wherein The first rotating means comprise: Lp1
- (a) a rotating shaft;
 - (b) a conical spindle at one end of the shaft;
 - (c) a propeller having in its hub a conical hole engaging The spindle;
 - (d) means for resiliently holding the propeller engaged around The spindle; and
 - (e) means for adjusting the pressure of the means for holding against the propeller.
8. The power plant claimed in claim 4 wherein the first means for coupling comprise a centrifugal clutch.
9. The power plant claimed in claim 7 installed into a vehicle.
10. The power plant claimed in claim 9 wherein The high pressure tank comprises a means for connecting The tank to an outside source of compressed air;
- A means for accumulating electrical energy comprises at least one electrical storage battery;
A second rotating means comprise a DC motor;
A third rotating means comprise a turbine powered by expansion of compressed air;
A second electrical energy generator comprise a generator of household alternating current; and
A means for distributing the household current to the vehicle electrical appliances.

The Motionless Generator of Richard Willis

This patent application covers a device which is claimed to have a substantially greater output power than the input power required to run it and it has no moving parts.

Patent application WO2009065210 (A1)

28th May 2009

Inventor: Richard Willis

ELECTRICAL GENERATOR

ABSTRACT

An electrical generator comprising an induction coil with a first magnet positioned adjacent to the first end of the induction coil so as to be in the electromagnetic influence of the induction coil when it is energised, and for creating a magnetic field around at least the first end of the induction coil. There is also a second magnet positioned near the second end of the induction coil so as to be in the electromagnetic field of the induction coil when the induction coil is energised, and for creating a magnetic field around at least the second end of the induction coil. A power input circuit powers the induction coil. A timer is placed in the power input circuit in order to create electrical pulses and controlling their timing. A power output circuit receives power from the induction coil.

FIELD OF THE INVENTION

The present invention relates to an electrical power generator, and more particularly to an "over-unity" electrical power generator.

BACKGROUND OF THE INVENTION

Electricity is conventionally generated in a number of ways, including fossil fuel powered electromechanical generators, coal powered electromechanical generators, water-flow powered electromechanical generators, nuclear reactor type generators, and so on. In each case, there are a number of disadvantages associated with these methods, especially inefficiency and also the scarcity of a power source.

Recently, magnetic generators have been developed which produce electrical power from the magnetic field of the Earth. Basically, an input magnetic field is quickly switched on and off, or alternatively more than one input magnetic field is selectively switched on and off, on an alternating basis, to influence a larger magnetic field in an electromagnetic apparatus that is selectively connected to an electrical power output circuit. A resulting electrical power is produced in the power output circuit.

There are even magnetic generator circuits which produce more electrical power than that which is applied to the circuit. While this seems to contradict the laws of physics, it does not, otherwise, such magnetic generator circuits would not work. These magnetic generator circuits work, on the basic principle that the space-time continuum is very energetic, including energy fields such as the Earth's magnetic field.

It should be understood that electric fields and magnetic fields do not have an independent existence. A purely electromagnetic field in one coordinate system can appear as a mixture of electric and magnetic fields in another coordinate system. In other words, a magnetic field can at least partially turn into an electric field, or vice versa.

It is also well known that a system which is far from equilibrium in its energy exchange with its environment can steadily and freely receive environmental energy and dissipate it in external loads. Such a system, can have a Coefficient of Performance ("COP") greater than 1. For a COP greater than 1, an electrical power system must take some, or all of its input energy, from its active external environment. In other words, the system must be open to receive and convert energy from its external environment, as opposed to merely converting energy from one form to another.

The US Patent 6,362,718 issued on 26th March 2002 to Patrick et al., discloses an electromagnetic generator without moving parts. This electromagnetic generator includes a permanent magnet mounted within a rectangular

ring-shaped magnetic core having a magnetic path to one side of the permanent magnet and a second magnetic path to the other side of the permanent magnet. A first input coil and a first output coil extend around portions of the first magnetic path, with the first input coil being at least partially positioned between the permanent magnet and the first output coil. A second input coil and a second output coil extend around portions of the second magnetic path, with the second input coil being at least partially positioned between the permanent magnet and the second output coil. The input coils are alternatively pulsed by a switching and control circuit and provide induced current pulses in the output coils. Driving electrical current through each of the input coils reduces a level of flux from the permanent magnet within the magnet path around which the input coil extends.

In an alternative embodiment of the Patrick et al electromagnetic generator, the magnetic core includes circular spaced-apart plates, with posts and permanent magnets extending in an alternating fashion between the plates. An output coil extends around each of these posts. Input coils extending around portions of the plates are pulsed to cause the induction of current within the output coils.

The apparent problems with the electric magnetic generator is disclosed in US Patent 6,362,718 seem to be twofold. First, it is more expensive to produce than necessary as it has four coils. Secondly, while it apparently achieves a Coefficient of Performance of more than 3.0, a much greater Coefficient of Performance is readily achievable. This is believed to be due to the specific physical configuration of the magnetic paths.

It is an object of the present invention to provide an electrical generator having a Coefficient of Performance significantly greater than 1.

SUMMARY OF THE INVENTION

In accordance with one aspect of the present invention there is disclosed a novel electrical generator comprising an induction coil. There is a first magnet positioned beside the first end of the induction coil so as to be in the electro-magnetic field of the induction coil when the induction coil is energised, and for creating a magnetic field around at least the first end of the induction coil. There is also a second magnet positioned near the second end of the induction coil so as to be in the electro-magnetic field of the induction coil when the induction coil is energised, and for creating a magnetic field around at least the second end of the induction coil. A power input circuit provides power to the induction coil. A timing device is placed in the input power circuit in order to create electrical pulses and for controlling the timing of those electrical pulses being passed to the induction coil. A power output circuit receives power from the induction coil.

Other advantages, features and characteristics of the present invention, as well as methods of operation and functions of the related elements of the structure, and the combination of parts and economies of manufacture, will become more apparent upon consideration of the following detailed description and the appended claims with reference to the accompanying drawings which are described here:

BRIEF DESCRIPTION OF THE DRAWINGS

The novel features which are believed to be characteristic of the electrical generator according to the present invention, as to its structure, organisation, use and method of operation, together with it's further objectives and advantages, will be better understood from the following drawings in which a preferred embodiment of the invention will now be illustrated by way of example. It is expressly understood, however, that the drawings are for the purpose of illustration and description only, and are not intended as a definition of the limits of the invention. In the accompanying drawings:

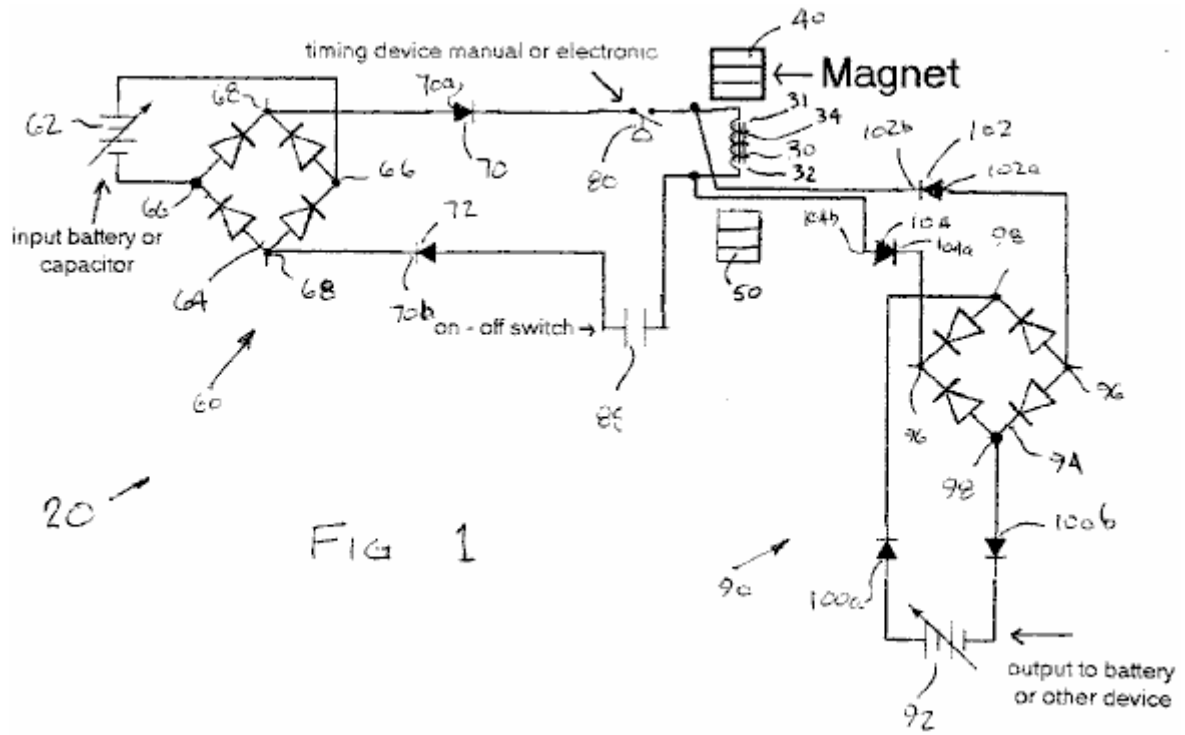

FIG 1

Fig.1 is an electrical schematic of the first preferred embodiment of the electrical generator.

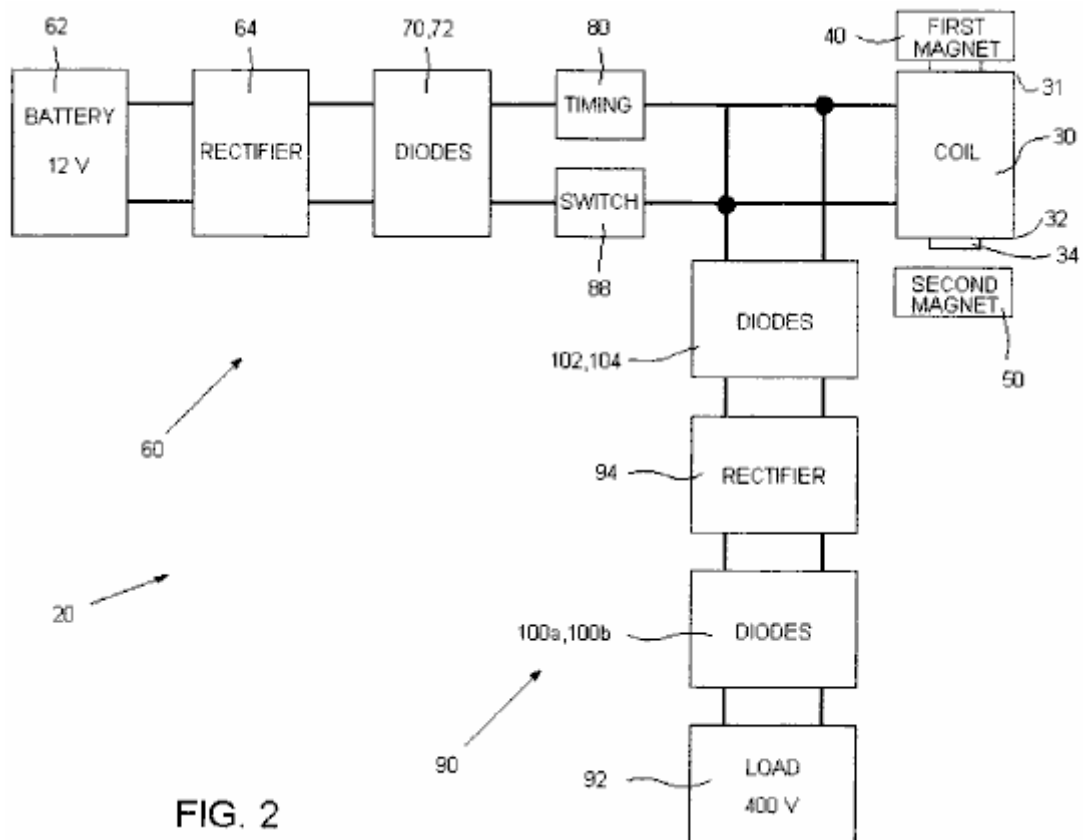

FIG. 2

Fig.2 is a block diagram schematic of the first preferred embodiment of the electrical generator of Fig.1.

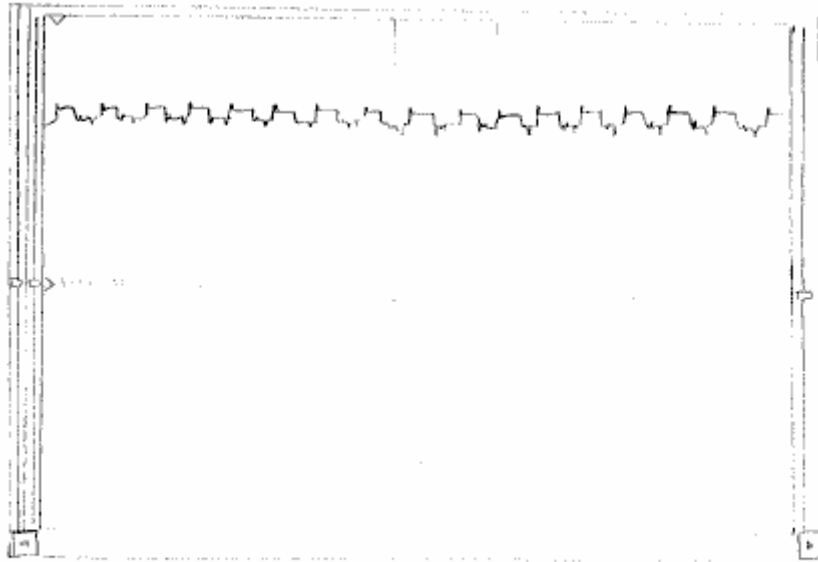

FIG. 3

Fig.3 is an oscilloscope waveform taken at the input power circuit after the timing mechanism.

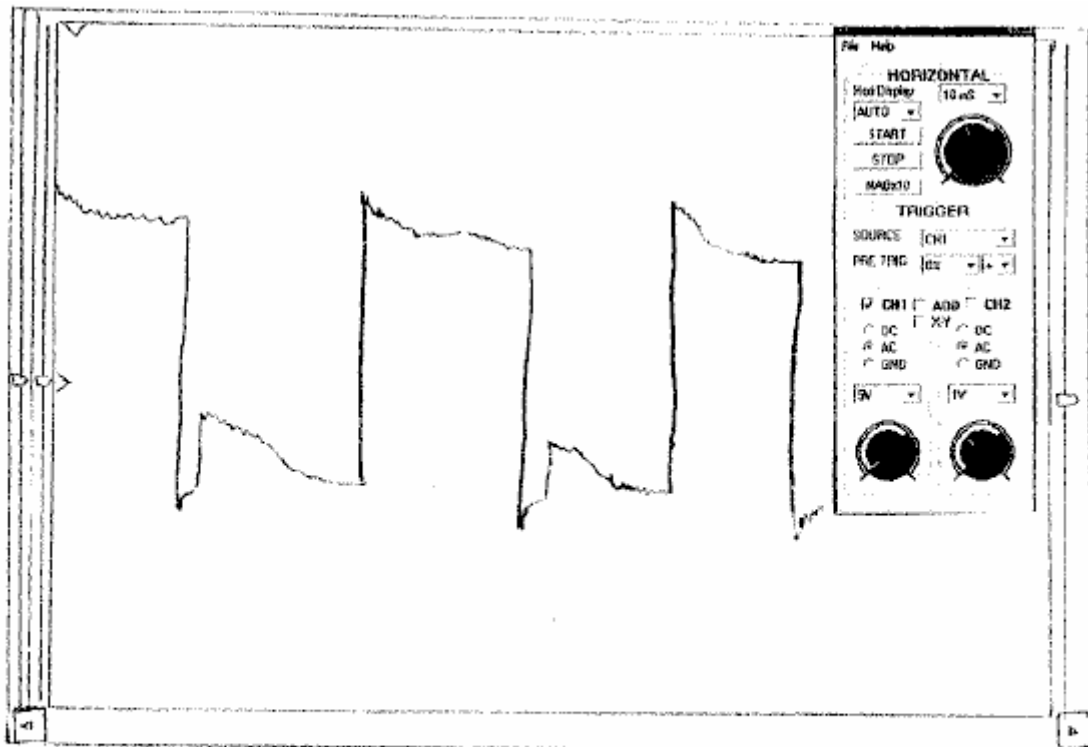

FIG. 4

Fig.4 is an oscilloscope waveform taken at the output power circuit before the first set of diodes immediately after the coil.

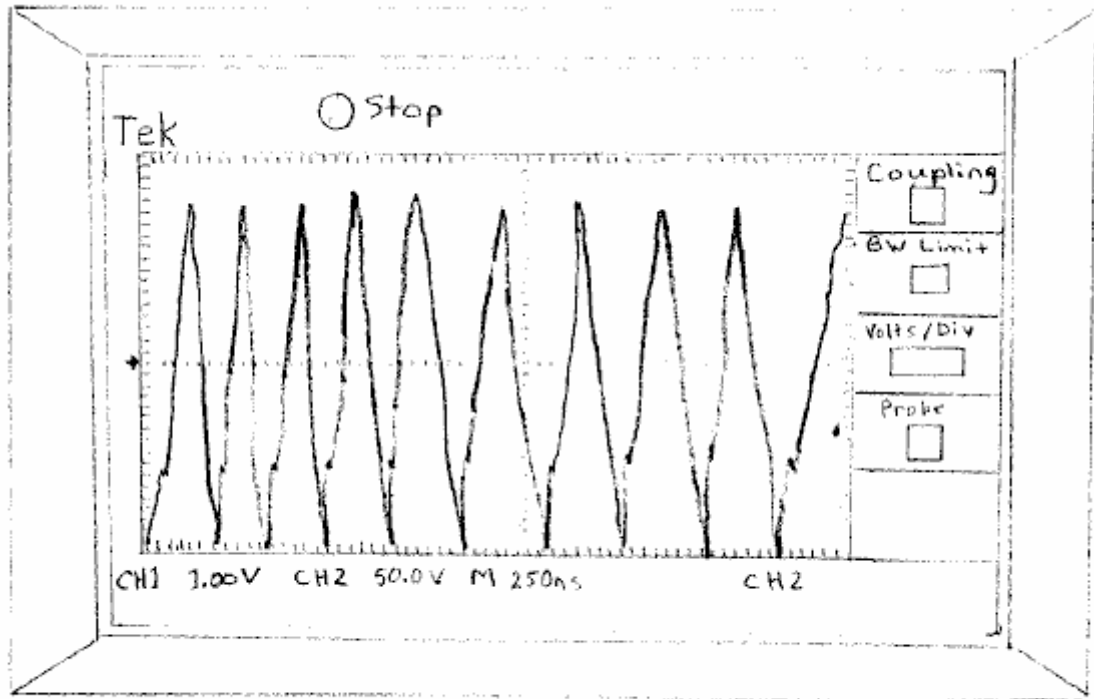

FIG. 5

Fig.5 is an oscilloscope waveform taken at the output power circuit at the load; and,

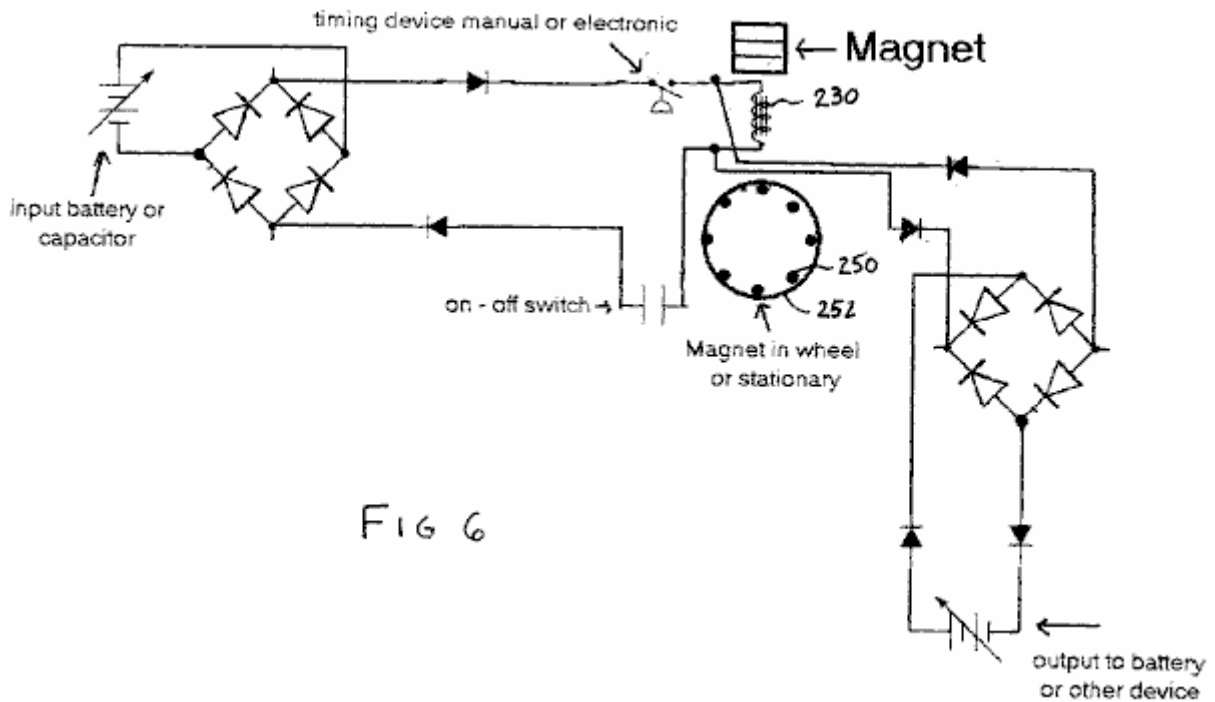

FIG 6

Fig.6 is an electrical schematic of the second preferred embodiment of the electrical generator

DETAILED DESCRIPTION OF THE PREFERRED EMBODIMENTS

Referring to **Fig.1** through **Fig.6** of the drawings, it will be noted that **Fig.1** through **Fig.5** illustrate a first preferred embodiment of the electrical generator of the present invention, and **Fig.6** illustrates a second preferred embodiment of the electrical generator of the present invention.

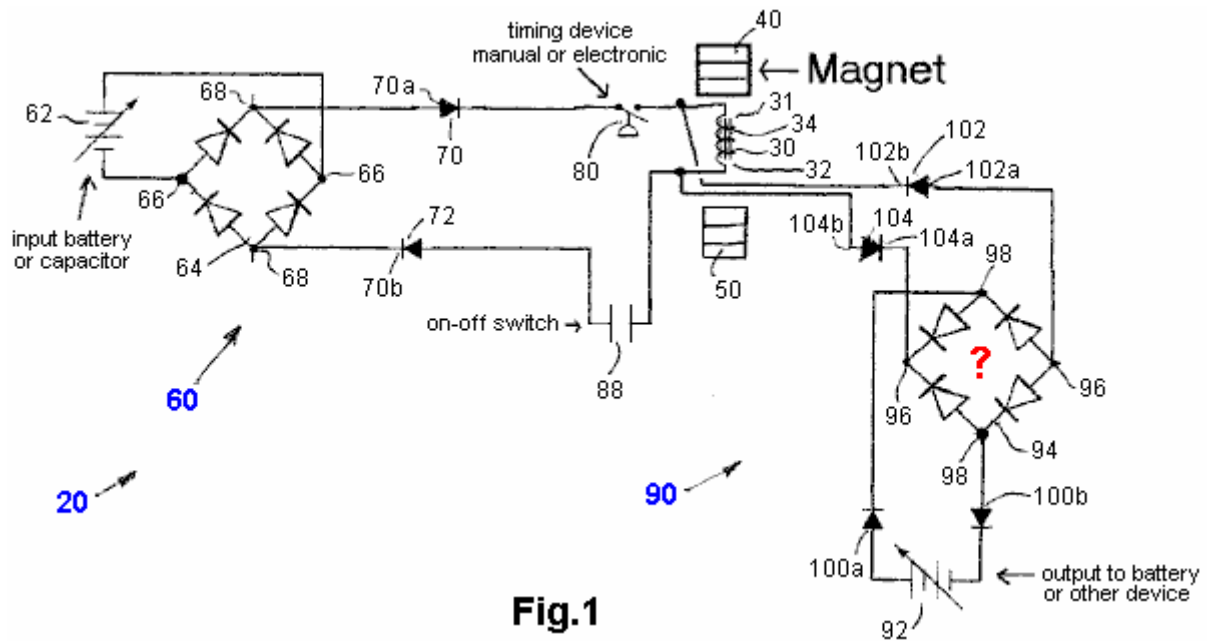

Fig.1

Reference will now be made to **Fig.1** through **Fig.5**, which show a first preferred embodiment of the electrical generator of the present invention, as indicated by general reference numeral **20**. The electrical generator **20** comprises an induction coil **30** having a first end **31** and a second end **32**. The induction coil **30** preferably includes a core **34** which is made from any suitable type of material, such as ferrite, mumetal, permalloy, cobalt, any non-permeable metal material, or any other suitable type of material. The coil **30** is wound with copper wire which can be a single size or multiple sizes depending on the size of the ferrite core **34**.

There is a first magnet **40** positioned adjacent to the induction coil **30**, preferably at the first end **31** so as to be within the electromagnetic field of the induction coil **30** when the induction coil **30** is energised. The first magnet **40** is a permanent magnet which has its North pole facing the first end **31** of the induction coil **30**. In the first preferred embodiment, the first magnet **40** is stationary with respect to the induction coil **30**, and even more preferably is in contact with, or is even secured to, the first end **31** of the induction coil **30**. The size of the coil and the copper wire used to wind the coil also depend on the size of the first magnet **40**. The first magnet **40** is there to create a magnetic field around at least the first end **31** of the first magnet **30**.

There is also a second magnet **50** positioned adjacent to the induction coil **30**, preferably at the second end **32** of the induction coil **30** but at a distance of about 1.0 cm or so from the coil core **34** but within the electromagnetic field of the induction coil **30** when the induction coil **30** is energised. The gap between the second end **32** of the induction coil **30** and the second magnet **50** can be an air gap or can be a vacuum.

The second magnet **50** is a permanent magnet which has its North pole facing the second end **32** of the induction coil **30**. In the first preferred embodiment, the second magnet **50** is stationary with respect to the induction coil **30**. The size of the coil and the copper wire used to wind it also depends on the size of the second magnet **50**. The second magnet **50** is there in order to create a magnetic field around at least the second end **32** of the induction coil **30**.

As can be seen in **Fig.1**, the first magnet **40** is positioned so its North pole is facing the first end **31** of the induction coil and its South pole is facing away from the first end **31** of the induction coil **30**. The first end **31** of the induction coil **30** creates a South magnetic field when it is energised. In this manner, the North pole of the first magnet **40** and the South pole of the first end **31** of the induction coil attract each other.

Similarly, but oppositely, the second magnet **50** is positioned so that its North pole is facing the second end **32** of the induction coil and its South pole is facing away from the second end **32** of the induction coil **30**. The second end **32** of the induction coil **30** creates a North magnetic field when the induction coil **30** is energised. In this manner, the North pole of the second magnet **50** and the North pole of the second end **32** of the induction coil repel each other.

A power input circuit section, as indicated by the general reference numeral **60**, is for providing power to the induction coil and is comprised of a source of electrical power **62**. In the first preferred embodiment, as illustrated, the input source of electrical power **62** comprises a DC power source, specifically a battery **62**, but additionally or alternatively may comprise a capacitor (not shown). The source of electrical power can range from less than 1.0 volt to more than 1,000,000 volts, and can range from less than 1.0 amp to more than 1 million amps. Alternatively, it is contemplated that the input source of electrical power could be an AC power source (not shown).

An input rectifier **64** which is preferably, but not necessarily, a full-wave rectifier **64**, has an input **66** electrically connected to the source of electrical power **62** and also has an output **68**. A first diode **70** is connected at its positive end **70a** to one terminal **68a** of the output **68** of the rectifier **62**. A second diode **72** is connected at its negative end **72a** to the other terminal **68b** of the output **68** of the rectifier **62**.

There is also a timing mechanism **80** in the input power circuit section **60**, which as shown, is electrically connected in series with the first diode **70**. This timing mechanism both creates electrical pulses and controls the timing of those electrical pulses which are fed to the induction coil **30**. The pulses are basically saw-tooth waveforms, as can be seen in **Fig.3**.

In the first preferred embodiment, the timing device **80** is a manual timer in the form of a set of "points" from the ignition system of a vehicle, as they can withstand high voltage and high current levels. Alternatively, it is contemplated that the timing mechanism could be an electronic timing circuit. It is also contemplated that a TGBT unit from a MIG welder could be used as the basis of the timing device **80**. It has been found that a timing device which provides a physical break in its "off" configuration works well as stray currents cannot backtrack through the circuit at that time. The timing mechanism can be of any suitable design so long as it can respond to the placement of the magnets **50** in the rotor **52** in the second preferred embodiment shown in **Fig.6**.

When the device is in use, the magnetic fields created by the first magnet **40** and the second magnet **50** in conjunction with the coil **30**, are each somewhat mushroom shaped, and oscillate back and forth, with respect to their size, in a manner corresponding to the timing of the electrical pulses from the power input circuit **60**, as controlled by the timing mechanism **80**.

The power input circuit **60** has an on/off switch **88** to allow disconnection of the power feed to the induction coil **30**. The on/off switch **88** may alternatively be located in any other suitable place in the power input circuit **60**.

A power output circuit section, indicated by the general reference numeral **90**, is for receiving power from the induction coil and comprises an electrical load **92**, which, in the first preferred embodiment is a battery **92**, but may additionally or alternatively comprise a capacitor (not shown), or any other suitable electrical load device.

The power output circuit portion **90** also has an output rectifier **94** having an input **96** an output **98** electrically connected to the electrical load **92** via a pair of forward biased diodes **100a**, **100b** which prevent the electrical load **92** from powering the induction coil **30**. A first diode **102** is electrically connected at its positive end **102a** to one terminal **94a** of the input of the rectifier **94** and is electrically connected at its negative end **102b** to one end of the induction coil **30**. A second diode **104** is connected at its negative end **104a** to the other terminal **94b** of the input of the rectifier **94** and is electrically connected at its positive end **104b** to the other end of the induction coil **30**. The output of the coil, taken before the diodes **102,104** is shown in **Fig.4**.

Note: It is highly likely that there is a clerical error in **Fig.1** because as it is drawn the bridge input is point **98** and not **96** as stated. If this is the case, then the two diode bridges are identical and the output section should be drawn like this:

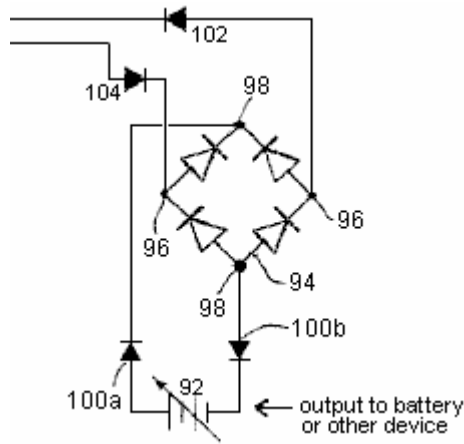

although it is by no means obvious why diodes 102 and 104 are needed as their function would appear to be provided by the output bridge diodes.

The output to the electrical load 92 of the power output circuit 90 can range from less than 1 volt to more than 1,000,000 volts, and can range from less than one amp to more than 1 million amps. As can be seen in Fig.5, the output to the electrical load 92 comprises generally spike-shaped pulses which have both negative and positive components.

As can be readily seen in Fig.1 and Fig.2, the input power circuit 60 is electrically connected in parallel with the induction coil 30 and the output power circuit portion 90 is electrically connected in parallel with the induction coil 30.

The various diodes and rectifiers in the electrical generator 20 can be of any suitable voltage from about 12 volts to over 1,000,000 volts, and can have slow recovery or fast recovery, as desired. Further, the various diodes and rectifiers may be configured in other suitable formats. There also may be additional capacitors added into the power output circuit adjacent to the electrical load 92 in order to increase the output power before discharge.

It has been found that setting the timing to six hundred pulses per minute (10 Hz) provides a waveform in the power output circuit portion 90 that comprises generally spike-shaped pulses with a period of about 20 nanoseconds. It is believed that the flux of the power pulses that are input into the induction coil 30 is quickly shifting the magnetic field back and forth in the induction coil 30, which is akin to the flux of the power pulses creating its own echo. The various electromagnetic oscillations in the coil provide a much higher frequency in the power output circuit 90 than in the power input circuit portion 60.

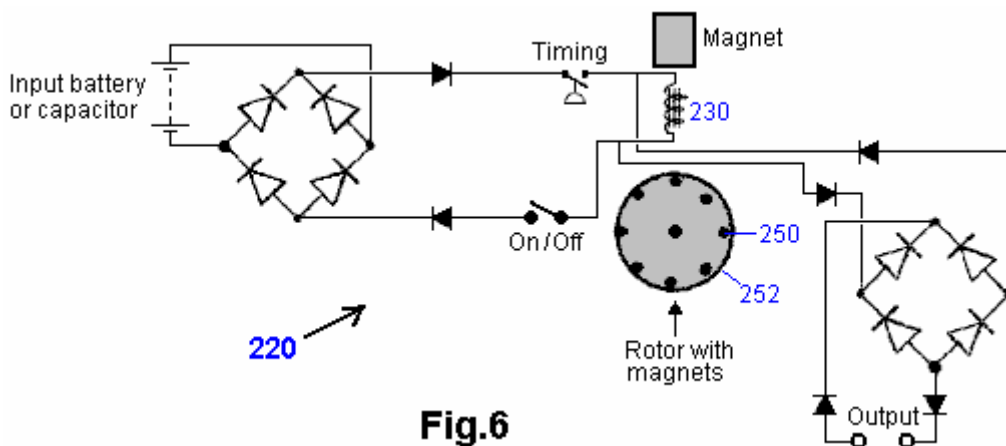

Fig.6

Reference will now be made to Fig.6, which shows a second preferred embodiment of the electrical generator of the present invention, as indicated by general reference numeral 220. The second preferred embodiment electrical generator is similar to the first preferred embodiment electrical generator 20 except that the second magnet comprises several moving magnets 250, typically eight permanent magnets 250. These magnets are mounted on a wheel 252, which is free to rotate. Ideally, these magnets are mounted in an identical way to each other on the rotor disc 252. If desired, there can be any suitable number of magnets mounted in the rotor. Accordingly, at least one rotor magnet 250 will be within the electromagnetic field of the induction coil 230 when the coil is energised. The rotor magnets can be of any suitable strength and any suitable type of magnet, and they may be mounted on the rotator by any suitable means, such as a suitable adhesive, or moulded into the disc

if the rotor is made of plastic. In practice, the rotor disc is driven round by the magnetic field of the induction coil when it is energised. It is also possible for the first magnet to a rotor magnet in the same manner as described for the second magnet **250**.

As can be understood from the above description and from the accompanying drawings, the present invention provides an electrical generator having a Coefficient of Performance greater than 1.0. and more specifically, an electrical generator which has a Coefficient of Performance significantly greater than 1.0. An electrical generator having a Coefficient of Performance significantly greater than 1.0 is at present, unknown in the prior art.

Other variations of the above principles will be apparent to those who are knowledgeable in the field of the invention, and such variations are considered to be within the scope of the present invention. Further, other modifications and alterations may be used in the design and manufacture of the electrical generator of the present invention without departing from the spirit and scope of the following claims:

CLAIMS

- 1.** An electrical generator comprising:
 - an induction coil having a first end and a second end;
 - a first magnet positioned adjacent said first end of said induction coil so as to be in the electromagnetic field of said induction coil when said induction coil is energised, and for creating a magnetic field around at least said first end of said induction coil,
 - a second magnet positioned adjacent said second end of said induction coil so as to be in the electro-magnetic field of said induction coil when said induction coil is energized, and for creating a magnetic field around at least said second end of said induction coil;
 - a power input circuit portion for providing power to said induction coil;
 - a limiting means in said power input circuit portion for creating electrical pulses and controlling the timing of said electrical pulses to said induction coil; and,
 - a power output circuit portion for receiving power from said induction coil.
- 2.** The electrical generator of claim 1 , wherein said first magnet is stationary with respect to said induction coil.
- 3.** The electrical generator of claim 2, wherein said first magnet comprises a permanent magnet.
- 4.** The electrical generator of claim 2, wherein said induction coil includes a core.
- 5.** The electrical generator of claim 4, wherein said first magnet is in contact with said core.
- 6.** The electrical generator of claim 4, wherein said core is made from a material chosen from the group of ferrite, mumetal, permalloy, and cobalt.
- 7.** The electrical generator of claim 4, wherein said core is made from a non-permeable metal material.
- 8.** The electrical generator of claim 3, wherein said second magnet is stationary with respect to said induction coil.
- 9.** The electrical generator of claim 8, wherein said second magnet comprises a permanent magnet.
- 10.** The electrical generator of claim 1, wherein said second magnet comprises at least one movable magnet.
- 11.** The electrical generator of claim 10. wherein said at least one movable magnet is mounted on a rotor.
- 12.** The electrical generator of claim 11 , wherein said at least one movable magnet comprises a plurality of magnets mounted on said rotor.
- 13.** The electrical generator of claim 1, wherein said power input circuit portion comprises a source of electrical power, a input rectifier having an input electrically connected to said source of electrical power and an output, a first diode connected at its positive end to one terminal of said input rectifier, a second diode connected at its negative end to the other terminal of said input rectifier.
- 14.** The electrical generator of claim 13, wherein said timing means is electrically connected in series with said first diode.
- 15.** The electrical generator of claim 14, wherein said power output circuit portion comprising an electrical load, an output rectifier having an output electrically connected to said electrical load via a pair of forward biased diodes and an input, a first diode connected at its negative end to one terminal of said output rectifier, a

second diode connected at its positive end to the other terminal of said output rectifier.

16. The electrical generator of claim 15, wherein said input power circuit portion is electrically connected in parallel with said induction coil and said output power circuit portion is electrically connected in parallel with said induction coil.
17. The electrical generator of claim 1, wherein said input source of electrical power comprises a DC power source.
18. The electrical generator of claim 17, wherein said DC power source comprises a battery.
19. The electrical generator of claim 17, wherein said DC power source comprises a capacitor.
20. The electrical generator of claim 1, wherein said input source of electrical power comprises an AC power source.
21. The electrical generator of claim 1 where the input rectifier is a Wheatstone bridge rectifier.
22. The electrical generator of claim 1, wherein said timing means comprises an electronic timing circuit.
23. The electrical generator of claim 1, wherein said timing means comprises a manual timer.
24. The electrical generator of claim 1, wherein said first magnet comprises a permanent magnet.
25. (Appears to have been omitted from the archived copy)
26. The electrical generator of claim 12, wherein said plurality of movable magnets are each mounted similarly one to another on said rotatable wheel.
27. The electrical generator of claim 1, wherein said electrical load comprises a battery.
28. The electrical generator of claim 1, further comprising an on/off switch electrically connected in said power input circuit portion.

The Motionless Generator of Graham Gunderson

Graham Gunderson's Solid-State Electric Generator is shown in US Patent Application 2006/0163971 A1 of 27th July 2006. The details are as follows:

Abstract

A solid-state electrical generator including at least one permanent magnet, magnetically coupled to a ferromagnetic core provided with at least one hole penetrating its volume; the hole(s) and magnet(s) being placed so that the hole(s) intercept flux from the permanent magnet(s) coupled into the ferromagnetic core. A first wire coil is wound around the ferromagnetic core for the purpose of moving the coupled permanent magnet flux within the ferromagnetic core. A second wire is routed through the hole(s) penetrating the volume of the ferromagnetic core, for the purpose of intercepting this moving magnetic flux, thereby inducing an output electromotive force. A changing voltage applied to the first wire coil causes coupled permanent magnet flux to move within the core relative to the hole(s) penetrating the core volume, thus inducing electromotive force along wire(s) passing through the hole(s) in the ferromagnetic core. The mechanical action of an electrical generator is therefore synthesised without the use of moving parts.

Background

This invention relates to a method and device for generating electrical power using solid state means.

It has long been known that moving a magnetic field across a wire will generate an electromotive force (EMF), or voltage, along the wire. When this wire is connected in a closed electrical circuit, an electric current, capable of performing work, is driven through this closed circuit by the induced electromotive force.

It has also long been known that this resulting electric current causes the closed circuit to become encircled with a secondary, induced magnetic field, whose polarity opposes the primary magnetic field which first induced the EMF. This magnetic opposition creates mutual repulsion as a moving magnet approaches such a closed circuit, and a mutual attraction as that moving magnet moves away from the closed circuit. Both these actions tend to slow or cause "drag" on the progress of the moving magnet, causing the electric generator to act as a magnetic brake, whose effect is in direct proportion to the amount of electric current produced.

Historically, gas engines, hydroelectric dams and steam-fed turbines have been used to overcome this magnetic braking action which occurs within mechanical generators. A large amount of mechanical power is required to produce a large amount of electrical power, since the magnetic braking is generally proportional to the amount of electrical power being generated.

There has long been felt the need for a generator which reduces or eliminates the well-known magnetic braking interaction, while nevertheless generating useful electric power. The need for convenient, economical and powerful sources of renewable energy remains urgent. When the magnetic fields within a generator are caused to move and interact by means other than applied mechanical force, electric power can be supplied without the necessity of consuming limited natural resources, thus with far greater economy.

Summary of the Invention

It has long been known that the source of the magnetism within a permanent magnet is a spinning electric current within ferromagnetic atoms of certain elements, persisting indefinitely in accord with well-defined quantum rules. This atomic current encircles every atom, thereby causing each atom to emit a magnetic field, as a miniature electromagnet.

This atomic current does not exist in magnets alone. It also exists in ordinary metallic iron, and in any element or metallic alloy which can be "magnetised", that is, any material which exhibits ferromagnetism. All ferromagnetic atoms and "magnetic metals" contain such quantum atomic electromagnets.

In specific ferromagnetic materials, the orientation axis of each atomic electromagnet is flexible. The orientation of magnetic flux both internal and external to the material, pivots easily. Such materials are referred to as magnetically "soft", due to this magnetic flexibility.

Permanent magnet materials are magnetically "hard". The orientation axis of each is fixed in place within a rigid crystal structure. The total magnetic field produced by these atoms cannot easily move. This constraint aligns the field of ordinary magnets permanently, hence the name "permanent".

The axis of circular current flow in one ferromagnetic atom can direct the axis of magnetism within another ferromagnetic atom, through a process known as "spin exchange". This gives a soft magnetic material, like raw

iron, the useful ability to aim, focus and redirect the magnetic field emitted from a magnetically hard permanent magnet.

In the present invention, a permanent magnet's rigid field is sent into a magnetically flexible "soft" magnetic material. the permanent magnet's apparent location, observed from points within the magnetically soft material, will effectively move, vibrate, and appear to shift position when the magnetisation of the soft magnetic material is modulated by ancillary means (much like the sun, viewed while underwater, appears to move when the water is agitated). By this mechanism, the motion required for generation of electricity can be synthesised within a soft magnetic material, without requiring physical movement or an applied mechanical force.

The present invention synthesises the virtual motion of magnets and their magnetic fields, without the need for mechanical action or moving parts, to produce the electrical generator described here. The present invention describes an electrical generator where magnetic braking known as expressions of Lenz's Law, do not oppose the means by which the magnetic field energy is caused to move. The synthesised magnetic motion is produced without either mechanical or electrical resistance. This synthesised magnetic motion is aided by forces generated in accordance with Lenz's Law, in order to produce acceleration of the synthesised magnetic motion, instead of physical "magnetic braking" common to mechanically-actuated electrical generators. Because of this novel magnetic interaction, the solid-state static generator of the present invention is a robust generator, requiring only a small electric force of operate.

Brief Description of the Drawings

The appended drawings illustrate only typical embodiments of this invention and are therefore not to be considered limiting of its scope, as the invention encompasses other equally effective embodiments.

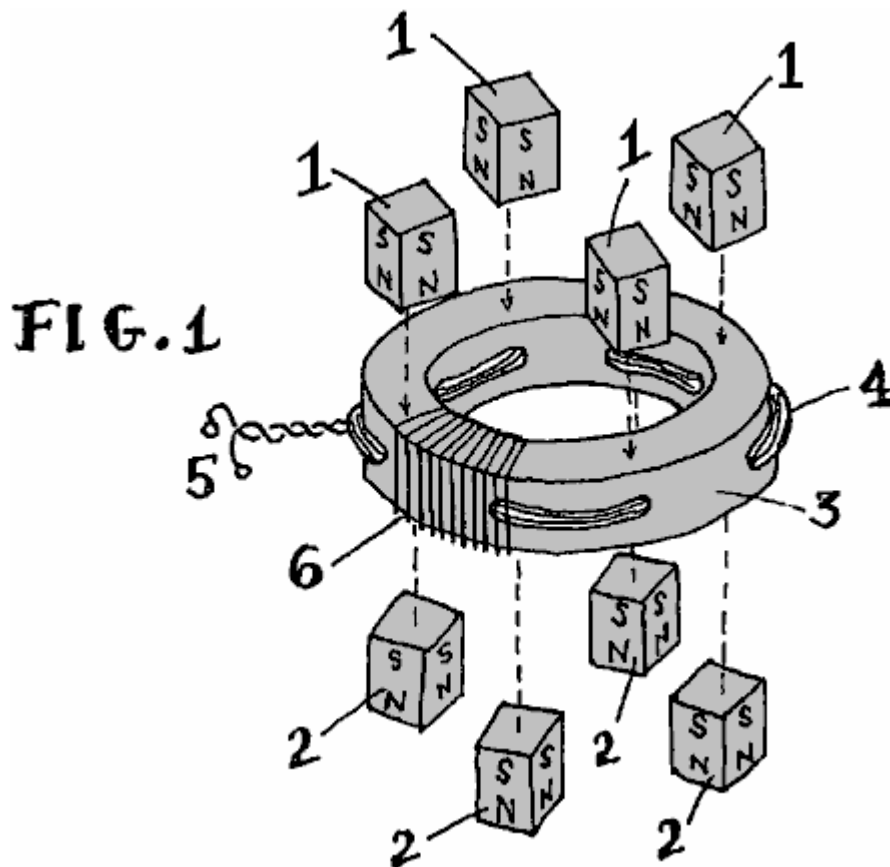

Fig.1 is an exploded view of the generator of this invention.

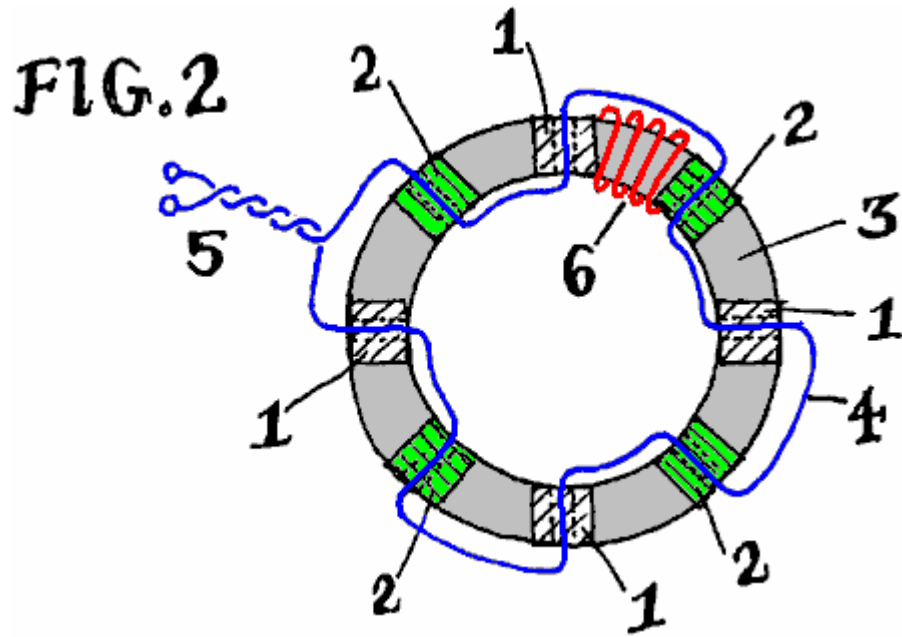

Fig.2 is a cross-sectional elevation of the generator of this invention.

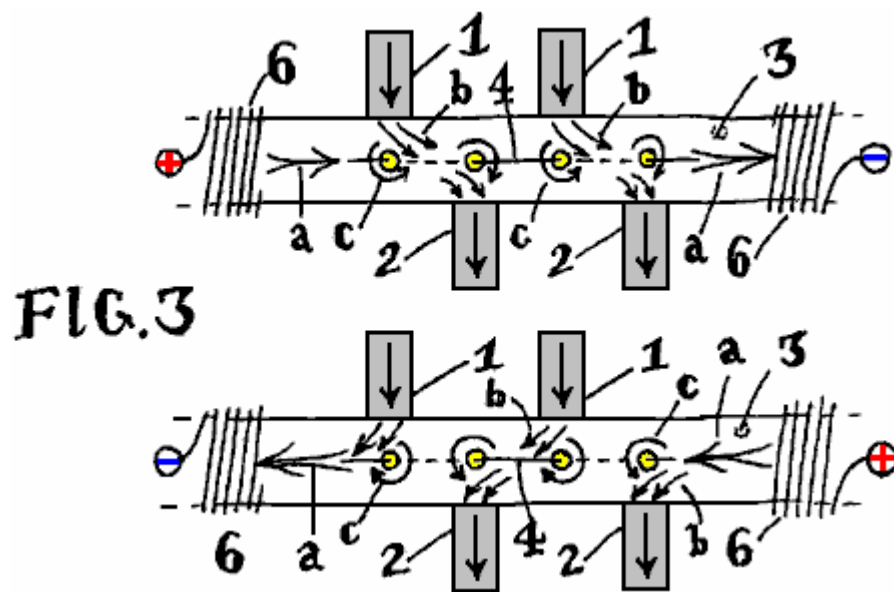

Fig.3 is a schematic diagram of the magnetic action occurring within the generator of Fig.1 and Fig.2.

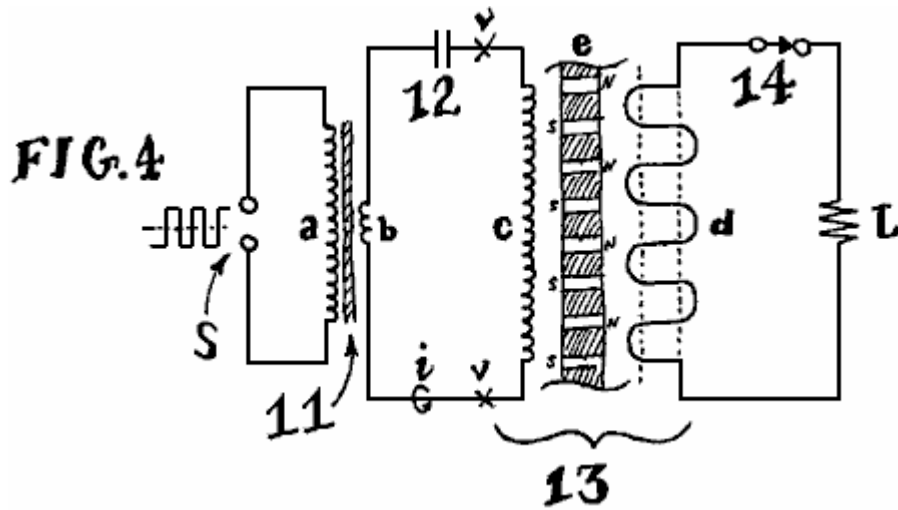
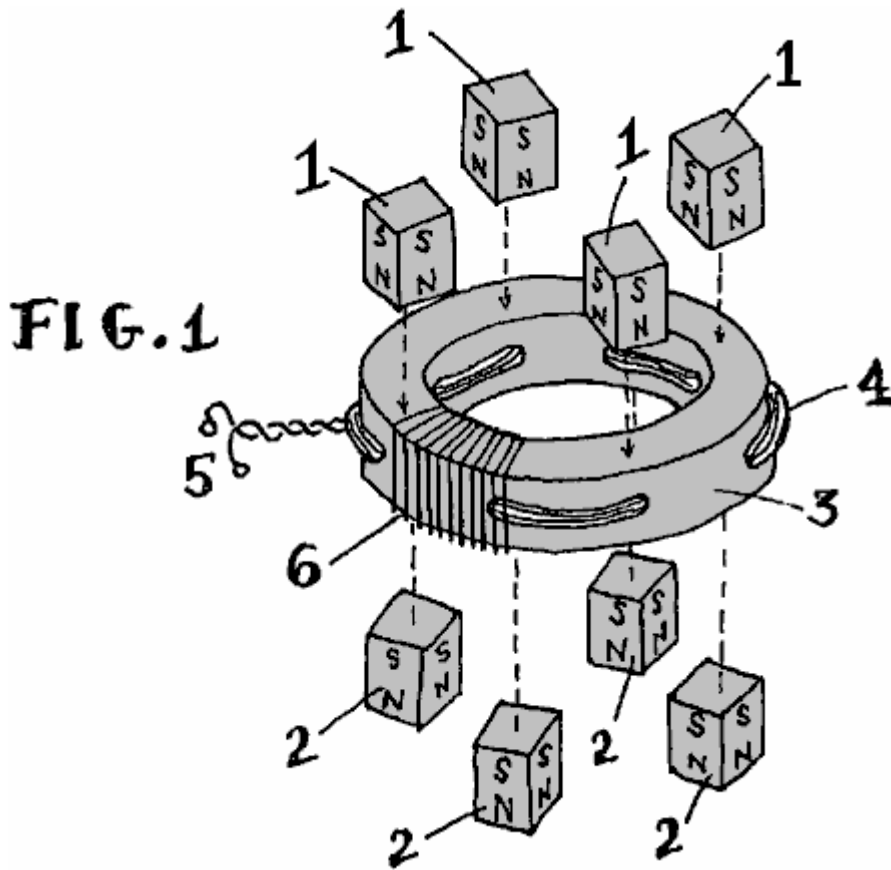

Fig.4 is a circuit diagram, illustrating one method of operating the electrical generator of this invention.

Detailed Description of the Invention

Fig.1 depicts a partially exploded view of an embodiment of an electrical generator of this invention. The part numbers also apply in Fig.2 and Fig.3.



Numeral 1 represents a permanent magnet with its North pole pointing inward towards the soft ferromagnetic core of the device. Similarly, numeral 2 indicates permanent magnets (preferably of the same size, shape and composition), with their South poles aimed inward towards the opposite side, or opposite surface of the device. The letters "S" and "N" denote these magnetic poles in the drawings. Other magnetic polarities and configurations may be used with success; the pattern shown merely illustrates one efficient method of adding magnets to the core.

The magnets may be formed of any polarised magnetic material. In order of descending effectiveness, the most desirable permanent magnet materials are Neodymium-Iron-Boron ("NIB"), Samarium Cobalt, AlNiCo alloy, or

“ceramic” Strontium-Barium or Lead-Ferrite. A primary factor determining permanent magnet material composition is the magnetic flux strength of the particular material type. In an embodiment of the invention, these magnets may also be substituted with one or more electromagnets producing the required magnetic flux. In another embodiment of the invention, a superimposed DC current bias can be applied to the output wire to generate the required magnetic flux, replacing or augmenting the permanent magnets.

Numeral **3** indicates the magnetic core. This core is a critical component of the generator. The core determines the output power capacity, the optimum magnet type, the electrical impedance and the operating frequency range. The core may be any shape, composed of any ferromagnetic material, formed by any process (sintering, casting, adhesive bonding, tape-winding, etc.). A wide range of shapes, materials and processes is known in the art of making magnetic cores. Effective common materials include amorphous metal alloys (such as sold under the “Metglas” trademark by Metglas Inc., Conway, S.C.), nanocrystalline alloys, manganese and zinc ferrites as well as ferrites of any suitable element including any combination of magnetically “hard” and “soft” ferrites, powdered metals and ferromagnetic alloys, laminations of cobalt and/or iron and silicon-iron “electrical steel”. This invention successfully utilises any ferromagnetic material, while functioning as claimed. In an embodiment of the invention, and for the purpose of illustration, a circular “toroid” core is illustrated. In an embodiment of the invention, the composition may be bonded iron powder, commonly available from many manufacturers.

Regardless of core type, the core is prepared with holes, through which, wires may pass. the holes are drilled or formed to penetrate the core’s ferromagnetic volume. The toroidal core **3** shown, includes radial holes pointing towards a common centre. If, for example, stiff wire rods were to be inserted through each of these holes, these rods would meet at the centre point of the core, producing an appearance similar to a wheel with spokes. If a square or rectangular core (not illustrated) is used, then these holes are preferably oriented parallel to the core’s flat sides, causing stiff rods passed through the holes to form a square grid pattern, as the rods cross each other in the interior “window” area framed by the core. While in other embodiments of the invention, these holes may take any possible orientation or patterns of orientation, a simple row of radial holes is illustrated as one example.

Numeral **4** depicts a wire, or bundle of wires which pick up and carry the output power of the generator. Typically, this wire is composed of insulated copper, though other materials such as aluminium, iron, dielectric material, polymers and semiconducting materials may be substituted. It may be seen in **Fig.1** and **Fig.2**, that wire **4** passes alternately through neighbouring holes formed in core **3**. The path taken by wire **4** undulates as it passes in opposite direction through each adjacent hole. If an even number of holes is used, the wire will emerge on the same side of the core on which it first entered. Once all the holes are filled, the resulting pair of trailing leads may be twisted together or similarly terminated, forming the output terminals of the generator shown at numeral **5**. Output wire **4**, may also make multiple passes through each hole in the core. Though the winding pattern is not necessarily undulatory, this basic form is shown as an example. Many effective connection styles exist. This illustration shows the most simple.

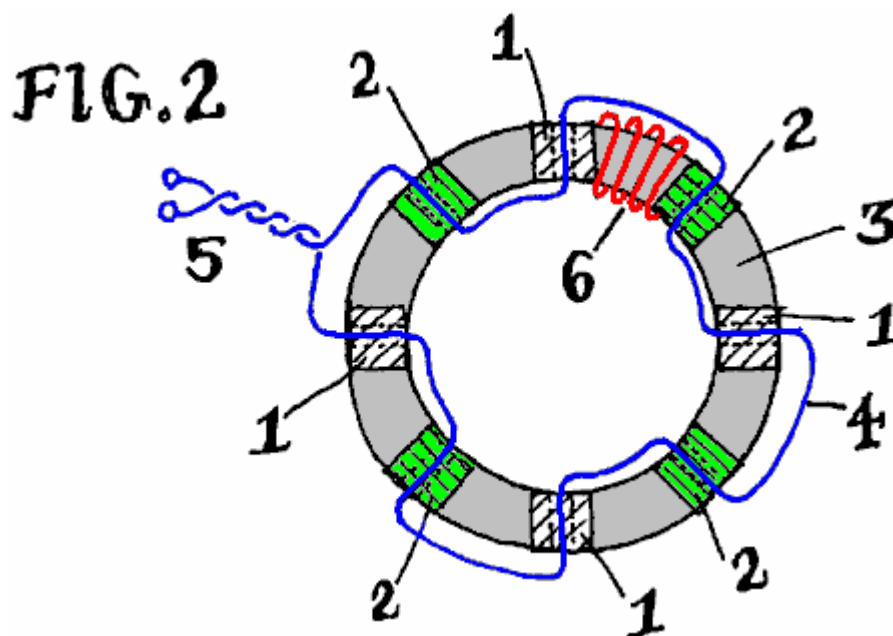

Numeral **6** in **Fig.1**, **Fig.2** and **Fig.3**, points to a partial illustration of the input winding, or inductive coil used to shift the fields of the permanent magnets, within the core. Typically, this wire coil encircles the core, wrapping around it. For the toroidal core shown, input coil **6** resembles the outer windings of a typical toroidal inductor - a common electrical component. For the sake of clarity, only a few turns of coil **6** are shown in each of **Fig.1**, **Fig.2**

and **Fig.3**. In practice, this coil may cover the entire core, or specific sections of the core, including, or not including the magnets.

Fig.2 shows the same electrical generator of **Fig.1**, looking transparently “down” through it from above, so that the relative positions of the core holes (shown as dotted lines), the path of the output wire **4**, and the position of the magnets (white hatched areas for magnets under the core and green hatched areas for magnets above the core) are made clear. The few representative turns of the input coil **6** are shown in red in **Fig.2**.

The generator illustrated, uses a core with 8 radially drilled holes. The spacing between these holes is equal. As shown, each hole is displaced by 45 degrees from each of its adjoining holes. The centres of all of the holes lie on a common plane lying half-way down the vertical thickness of the core. Cores of any shape or size may have as few as two or as many as hundreds of holes and a similar number of magnets. Other variations exist, such as generators with multiple rows of holes, zigzag and diagonal patterns, or output wire **4** moulded directly into the core material. In any case, the basic magnetic interaction shown in **Fig.3** occurs for each hole in the core as described below.

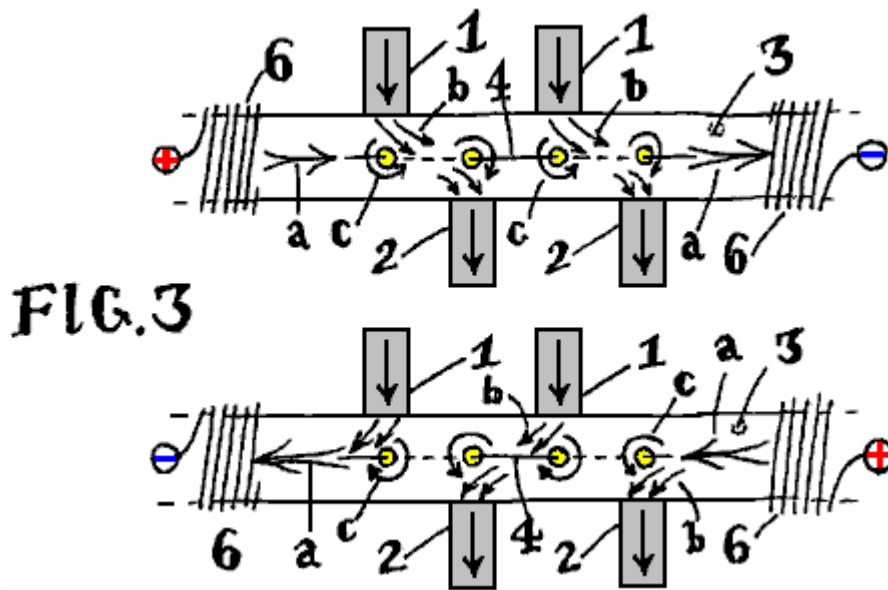

Fig.3 shows the same design, viewed from the side. The curvature of the core is shown flattened on the page for the purpose of illustration. The magnets are represented schematically, protruding from the top and bottom of the core, and including arrows indicating the direction of magnetic flux (the arrow heads point to the magnet’s North pole).

In practice, the free, unattached polar ends of the generator’s magnets may be left “as-is” in open air, or they may be provided with a common ferromagnetic path linking the unattached North and South poles together as a magnetic “ground”. The common return path is typically made of steel, iron or similar material, taking the form of a ferrous enclosure housing the device. It may serve the additional purpose of a protecting chassis. The magnetic return may also be another ferromagnetic core of a similar electric generator stacked on top of the illustrated generator. There can be a stack of generators, sharing common magnets between the generator cores. Any such additions are without direct bearing on the functional principle of the generator itself, and have therefore been omitted from these illustrations.

Two example flux diagrams are shown in **Fig.3**. Each example is shown in a space between schematically depicted partial input coils **6**. A positive or negative polarity marker indicates the direction of input current, applied through the input coil. This applied current produces “modulating” magnetic flux, which is used to synthesise apparent motion of the permanent magnets, and is shown as a double-tailed horizontal arrow (**a**) along the core **3**. Each example shows this double-tailed arrow (**a**) pointing to the right or to the left, depending on the polarity of the applied current.

In either case, vertical flux entering the core (**b,3**) from the external permanent magnets (**1,2**) is swept along within the core, in the direction of the double-tailed arrow (**a**), representing the magnetic flux of the input coil. These curved arrows (**b**) in the space between the magnets and the holes, can be seen to shift or bend (**a** --> **b**), as if they were streams or jets of air subject to a changing wind.

The resulting sweeping motion of the fields of the permanent magnets, causes their flux (**b**) to brush back and forth over the holes and wire **4** which passes through these holes. Just as in a mechanical generator, when the

magnetic flux brushes or “cuts” sideways across a conductor in this way, voltage is induced in the conductor. If an electrical load is connected across the ends of this wire conductor (numeral **5** in **Fig.1** and **Fig.2**), a current flows through the load via this closed circuit, delivering electrical power able to perform work. Input of an alternating current across the input coil **6**, generates an alternating magnetic field (**a**) causing the fields of permanent magnets **1** and **2** to shift (**b**) within the core **3**, inducing electrical power through a load (attached to terminals **5**), as if the fixed magnets (**1,2**) themselves were physically moving. However, no mechanical motion is present.

In a mechanical generator, induced current powering an electrical load, returns through output wire **4**, creating a secondary induced magnetic field, exerting forces which substantially oppose the original magnetic field inducing the original EMF. Since load currents induce their own, secondary magnetic fields opposing the original act of induction in this way, the source of the original induction requires additional energy to restore itself and continue generating electricity. In mechanical generators, the energy-inducing motion of the generator’s magnetic fields is being physically actuated, requiring a strong prime mover (such as a steam turbine) to restore the EMF-generating magnetic fields’ motion against the braking effect of the output-induced magnetic fields (the induced field **c** and the inducing field **b**), destructively in mutual opposition, which must ultimately be overcome by physical force, which is commonly produced by the consumption of other energy resources.

The electrical generator of the present invention is not actuated by mechanical force. It makes use of the induced secondary magnetic field in such a way as to not cause opposition, but instead, addition and resulting acceleration of magnetic field motion. Because the present invention is not mechanically actuated, and because the magnetic fields do not act to destroy one another in mutual opposition, the present invention does not require the consumption of natural resources in order to generate electricity.

The present generator’s induced magnetic field, resulting from electrical current flowing through the load and returning through output wire **4**, is that of a closed loop encircling each hole in the core. The induced magnetic fields create magnetic flux in the form of closed loops within the ferromagnetic core. The magnetic field “encircles” each hole in the core which carries output wire **4**. This is similar to the threads of a screw “encircling” the shaft of the screw.

Within this generator, the magnetic field from output wire **4** immediately encircles each hole formed in the core (**c**). Since wire **4** may take an opposing direction through each neighbouring hole, the direction of the resulting magnetic field will likewise be opposite. The direction of arrows (**b**) and (**c**) are, at each hole, opposing, headed in opposite directions, since (**b**) is the inducing flux and (**c**) is the induced flux, each opposing one another while generating electricity.

However, this magnetic opposition is effectively directed against the permanent magnets which are injecting their flux into the core, but not the source of the alternating magnetic input field **6**. In the present solid-state generator, induced output flux (**4,c**) is directed to oppose the permanent magnets (**1,2**) not the input flux source (**6, a**) which is synthesising the virtual motion of those magnets (**1,2**) by it’s magnetising action on core **3**.

The present generator employs magnets as the source of motive pressure driving the generator, since they are the entity being opposed or “pushed against” by the opposing reaction induced by output current which is powering a load. Experiments show that high-quality permanent magnets can be magnetically “pushed against” in this way for very long periods of time, before becoming demagnetised or “spent”.

Fig.3 illustrates inducing representative flux arrows (**b**) directed oppositely against induced representative flux (**c**). In materials typically used to form core **3**, fields flowing in mutually opposite directions tend to cancel each other, just as positive and negative numbers of equal magnitude sum to zero.

On the remaining side of each hole, opposite the permanent magnet, no mutual opposition takes place. Induced flux (**c**) caused by the generator load current remains present; however, inducing flux from the permanent magnets (**b**) is not present since no magnet is present, on this side, to provide the necessary flux. This leaves the induced flux (**c**) encircling the hole, as well as input flux (**a**) from the input coils **6**, continuing its path along the core, on either side of each hole.

On the side of each hole in the core where a magnet is present, action (**b**) and reaction (**c**) magnetic flux substantially cancel each other, being directed in opposite directions within the core. On the other side of each hole, where no magnet is present, input flux (**a**) and reaction flux (**c**) share a common direction. Magnetic flux adds together in these zones, where induced magnetic flux (**c**) aids the input flux (**a**). This is the reverse of typical generator action, where induced flux (**c**) is typically opposing the “input” flux originating the induction.

Since the magnetic interaction is a combination of magnetic flux opposition and magnetic flux acceleration, there is no longer an overall magnetic braking or total opposition effect. The braking and opposition is counterbalanced

by a simultaneous magnetic acceleration within the core. Since mechanical motion is absent, the equivalent electrical effect ranges from idling, or absence of opposition, to a strengthening and overall acceleration of the electrical input signal (within coils 6). proper selection of the permanent magnet (1,2) material and flux density, core 3 material magnetic characteristics, core hole pattern and spacing, and output medium connection technique, create embodiments where the present generator will display an absence of electrical loading at the input and/or an overall amplification of the input signal. This ultimately causes less input energy to be required in order to work the generator. Therefore, as increasing amounts of energy are withdrawn from the generator as output power performing useful work, decreasing amounts of energy are generally required to operate it. This process continues, working against the permanent magnets (1,2) until they are demagnetised.

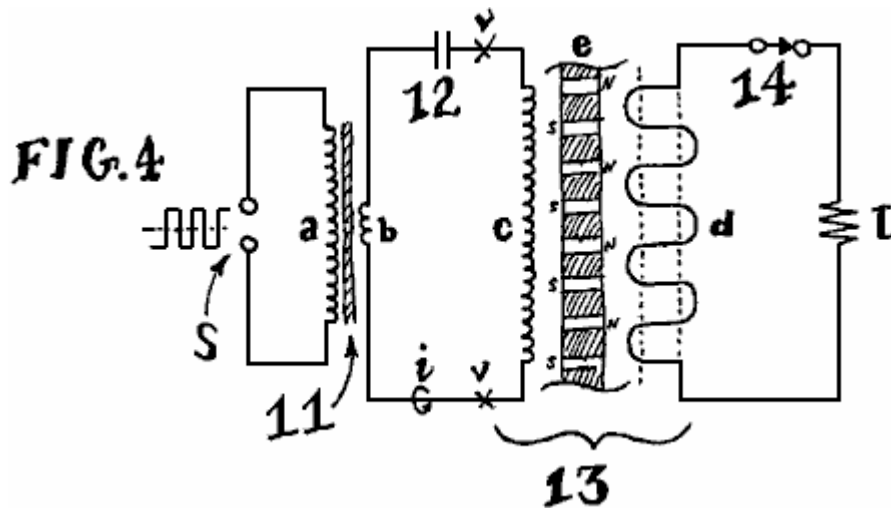

In an embodiment of this invention, **Fig.4** illustrates a typical operating circuit employing the generator of this invention. A square-wave input signal from a transistor switching circuit, is applied at the input terminals (**S**), to the primary (**a**) of a step-down transformer **11**. The secondary winding (**b**) of the input transformer may be a single turn, in series with a capacitor **12** and the generator **13** input coil (**c**), forming a series resonant circuit. The frequency of the applied square wave (**S**) must either match, or be an integral sub-harmonic of the resonant frequency of this 3-element transformer-capacitor-inductor input circuit.

Generator **13** output winding (**d**) is connected to resistive load **L** through switch **14**. When switch **14** is closed, generated power is dissipated at **L**, which is any resistive load, for example, and incandescent lamp or resistive heater.

Once input resonance is achieved, and the square-wave frequency applied at **S** is such that the combined reactive impedance of total inductance (**b + c**) is equal in magnitude to the opposing reactive impedance of capacitance **12**, the electrical phases of current through, and voltage across, generator **13** input coil (**c**) will flow 90 degrees apart in resonant quadrature. Power drawn from the square-wave input energy source applied to **S** will now be at a minimum.

In this condition, the resonant energy present at the generator input may be measured by connecting a voltage probe across the test points (**v**), situated across the generator input coil, together with a current probe around point (**i**), situated in series with the generator input coil (**c**). The instantaneous vector product of these two measurements indicates the energy circulating at the generator's input, ultimately shifting the permanent magnets' fields in order to create useful induction. This situation persists until the magnets are no longer magnetised.

It will be apparent to those skilled in the art that a square (or other) wave may be applied directly to the generator input terminals (**c**) without the use of other components. While this remains effective, advantageous re-generating effects may not be realised to their fullest extent with such direct excitation. Use of a resonant circuit, particularly with inclusion of a capacitor **12** as suggested, facilitates recirculation of energy within the input circuit, generally producing efficient excitation and a reduction of the required input power as loads are applied.

Mark McKay's Investigation of Edwin Gray's Technology: Part 1

Enter.... The Mallory Connection

Mark McKay, PE 3/2/06



E.V. Gray Version 2.0 type Motor EMA6 1977 – Courtesy Dr. Peter Lindemann

Consider the now classic 1977 photo (above) of Mr. E.V. Gray demonstrating his EMA6 motor to investors at the Sportsman Lodge in Burbank, CA. This photo was taken by Tom Valentine, who wrote a series of informative articles about the EV Gray saga. Dr. Peter Lindemann received this original film from Mr. Valentine to support Peter's research for his book "The Free Energy Secrets of Cold Electricity".

In a fruitful attempt to extract additional technical information from this historical photo Dr. Lindemann arranged to have it digitally enhanced. One of the goals of this effort was to decipher the writing on the large gray storage capacitor directly under the motor. It read:

**MALLORY
MADE IN U.S.A.
TYPE TVC-606
5.0 MFD 5000 VDC**

Mallory is a well known name in the field of electronics. When one thinks of Mallory today they generally think of the premium large blue electrolytic filter capacitors that dominated the high end linear power supply market in the 70's and 80's. At its peak, the P.R. Mallory Company was a power house of US made electrical components. Not only did they make several lines of capacitors but they also made Battery Chargers, Resistors, Rheostats, Rectifiers, Switches, UHF Converters, Noise Filters, Soldering Iron Tips, and Special Television Components. Their 1955 Catalog was 60 pages long.

Mr. P.G. Mallory started out in 1916 with the invention of the Mercury Battery. By 1965 the company developed the well known Duracell Alkaline battery.



The North America Capacitor Company (NACC) is headquartered in Indianapolis, Indiana. Today, NACC continues to manufacture and market Mallory capacitors at its modern manufacturing and warehouse facilities located in Greencastle, Indiana and Glasgow, Kentucky



Mallory Capacitors and Duracell Batteries from Author's Experimental Parts Reserve

Another important Mallory invention, very relative to the EV Gray technology, was the 1920's development of the "Elkonode", better known back then as simply the "vibrator". Today this device is hardly known at all. In its time it served as a vital sub-system in early DC converters. These were used to raise the low voltage levels of storage batteries to the operating levels required by vacuum tubes, which was 200 to 500 VDC. This now forgotten electro-mechanical component was the functional equivalent of two push-pull power transistors in a modern

switch-mode power supply. At the time, when it came to mobile electronics there were two choices. 1) A vibrator based power converter, or 2) A heavy dynamo-motor base converter. For applications under 30 watts the vibrator approach was smaller, lighter, cheaper, and more efficient than the alternative. Therefore, the military had a serious interest this technology, but it was in the mass market demand for small vacuum tube car radios where the real money was made.

The P.G. Mallory Co. almost completely dominated the top end power vibrator market for 40 years and was responsible for almost all of the performance improvements through the 40's and 50's. But, all good things must end. This lucrative product line came to a screeching halt in 1957 with the development of low voltage signal and power transistors. But Mallory still managed to keep a cutting edge in many of its other market areas for several years after that.



So, it is no big surprise when one reads in the 1973 Scagnetti EV Gray article:

The Engine that Runs Itself

By Jack Scagnetti from 'Probe The Unknown' in June 1973.

“Mallory Electric Corporation of Carson City, Nevada, has also made a major contribution toward the design of the electronic pulsing system.”

It's all pretty obvious that Mr. Gray had a huge investment in Mallory type components. If his invention did become main stream then the Mallory Co. would have had first shot at a huge new automotive market. Each new vehicle would need between \$300 - \$600 worth of rugged HV storage capacitors, not to mention an investment of twice that much for vibrator power converters or their equivalent solid state replacements, which Mallory made also.

It is real easy to see how Mr. Gray could have convinced a few executives at Mallory how it would be in their best interests to help him out financially, or at least provide him with a little hardware donation from their Vibrapack division in Irvine CA. Mr. Grays impressive “hands-on” demonstrations were known to be very effective at convincing technical professionals that he was on to something big, providing that he was ever allowed the opportunity to make such presentation to a real decision maker. Most likely some inspired and insightful 3rd level staff person managed to fix him up with a pickup load of surplus vibrator converters that were, or would be, completely obsolete.

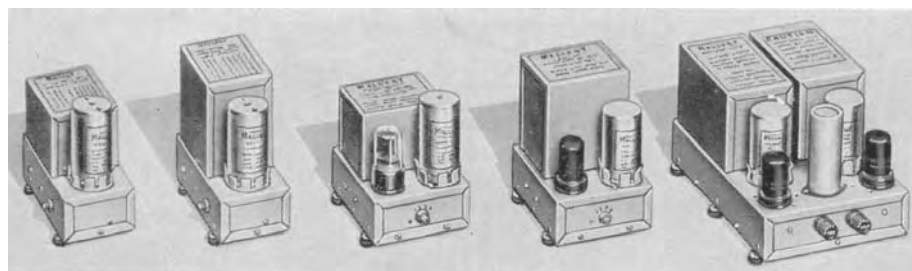

Examples of the P.R. Mallory line of “Vibrapacks” (DC Converters) from 1955 Catalog

All models have a 30 Watt power rating except the one on the far right which is rated at 60 Watts

But this story has an important twist in it.....

The Mallory Company that gave Mr. Gray enough money to make mention of it in the above magazine article was not the P. G. Mallory & Company Inc. but the Mallory Electric Company of Carson City, Nevada, designers and manufactures of a multitude of OEM and after-market automotive ignition systems.



HyFire® VI-A Microprocessor Controlled CD Ignition



ProMaster Classic
Mallory ProMaster Classic Series Ignition Coil



Chrome Electronic Ignition Coil

A Small Sample of modern Mallory brand name After Market Ignition Products 2006

Mr. Marion Mallory was the rare sort of independent individual who would start a company on Friday the 13th in February of 1925. He was a self-made inventor with a 4th grade education who was not only brilliant at his craft but also had what it takes to manage a business. If he ever met Mr. Gray face to face the two men would have had a lot in common, especially from a "hands-on" creative energy standpoint. Mr. Mallory made his money in a variety of automotive, motor cycle and marine ignition systems. For years he was the main supplier to the Ford Motor Company for ignition distributors and their upgrades. He received about 30 US and 10 international patents for a multitude of significant improvements in ignition technology, both in electrical and mechanical systems. He

was darn good at business, but his personal weakness was high performance auto racing. The market for race car parts is not very big, but the activity it supports is very addictive. Marion sponsored as many as three teams a year in the various classes of professional auto racing. It is also been said that Mr. Mallory looked for and hired like minded creative engineers and technicians. He also despised the union worker mentality that had become so adversarial in the Detroit area between the 50's and 60's.

Mr. Mallory finally got fed up with the stifling and counter-productive demands of the United Auto Workers Union. In a rare act of individualism he decided to make arrangements to move his entire company, lock, stock and, ignition coils to Carson City, NV. At this time Marion was getting along in years and unfortunately never made the move. He died in 1968 at the age of 70. His son 'Boot' Mallory was then handed the reins of this privately held company. 'Boot' terminated all the Union labor and kept 10 of the most productive engineers and technicians who were willing to relocate to the new factory. This facility was opened in 1969. From all accounts the "heir apparent" and only son was very motivated, technically competent, savvy at business, and like his father hopelessly addicted to high performance auto racing.

Given the timing of events it is most likely that Mr. Gray never met Marion Mallory. It is almost certain that the connection to the Mallory Company was entirely between Mr. Gray and 'Boot' Mallory. This was also helped by the fact these two men were about the same age with Mr. Gray being 5 years older.

For their entire business careers Marion and 'Boot' Mallory were always on the look out for improved ignition systems, both for good business practice and, of course, a desire to sport the fastest cars at the race track. Their knowledge base and field experience covered all approaches to ignition system design, both in the electrical and mechanical areas. It is interesting to note that they developed and manufactured magneto systems as well as traditional distributor systems. Understand that these two technologies are vastly different to each other.

No. 609,250.

Patented Aug. 16, 1898.

N. TESLA.
ELECTRICAL IGNITER FOR GAS ENGINES.

(No Model.)

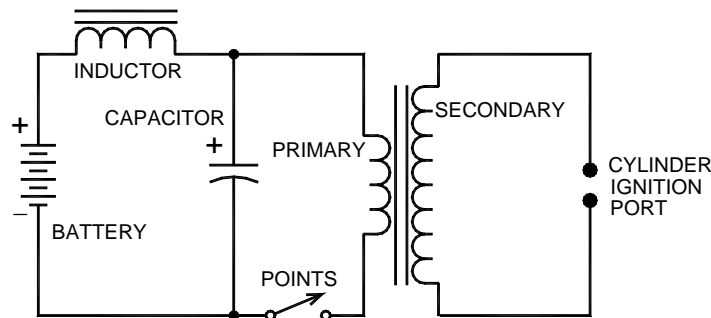
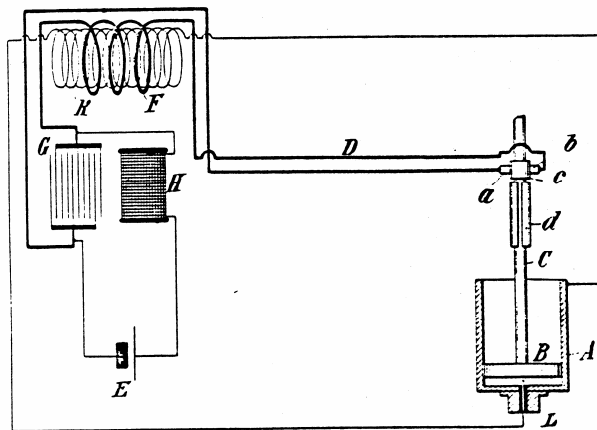

SCHEMATIC FOR TESLA'S "ELECTRICAL IGNITER FOR GAS-ENGINES"
US PATENT 609,250 AUGUST 1898

FIG. 7 (From The Complete Patents of Nikola Tesla)

In the auto racing circles it has always been known that capacitive discharge ignitions system are far superior to the limitations of the standard Kettering induction system, especially at high RPM. Dr. Tesla patented the first CD ignition system as early as 1898 but it was never produced because of serious design and component limitations. Marion Mallory and his engineers did get a working capacitive-discharge system finally connected to a race car engine in 1948. This first design was built employing a thyatron gas tube and vacuum-tube circuitry. As a result, it was costly, bulky, and unwieldy, not to mention fragile and economical unfeasible. But despite all of its failings the Capacitive Discharge Systems (CD) clearly showed its superior performance in the laboratory and on the track. Had it not been for the random and sudden failure of these alpha-test units (because of vibration) they might have still been used in professional auto racing, regardless of their unit cost.

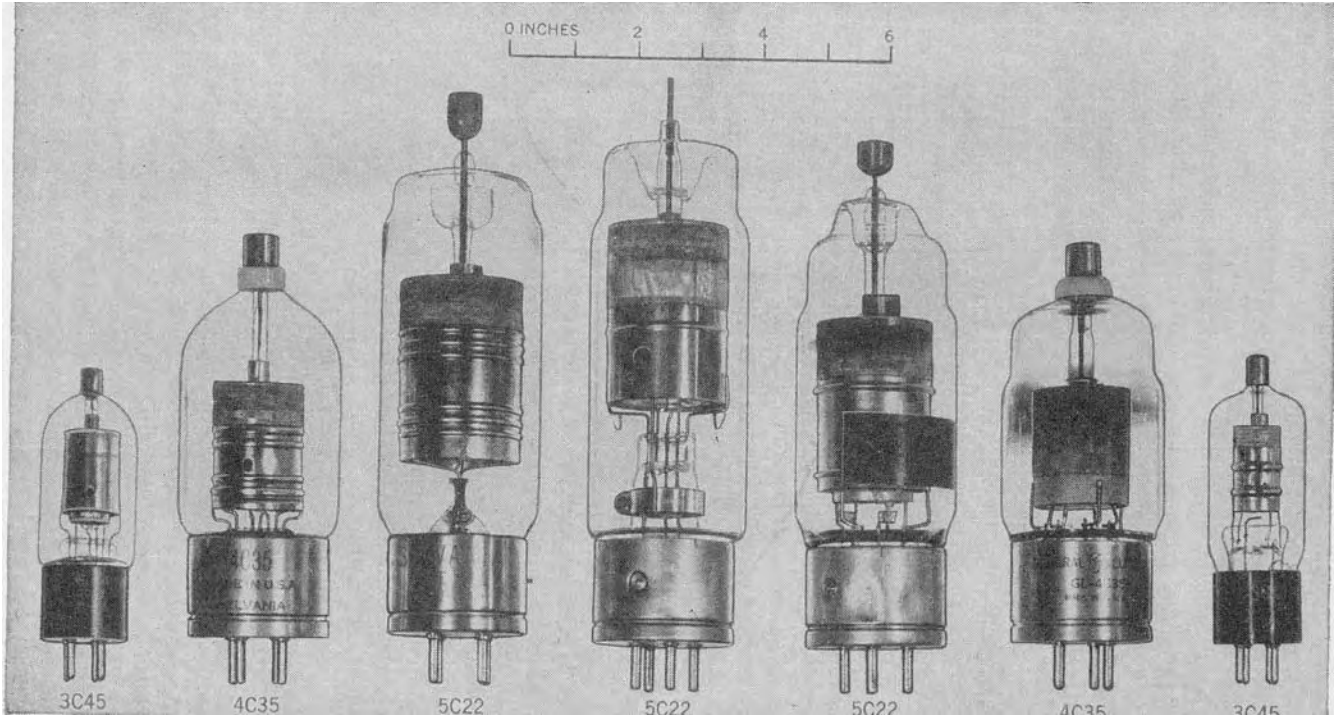

Glass Hydrogen Thyratrons of the 40's
From "Pulse Generators" Radiation Laboratory MIT 1948

Two new technologies were needed to get CD systems off the ground.

- 1) Some method to boost the 6 or 12 V DC storage battery voltage to the 400-500 Volt range with an available current of at least 100 mA. (40-50 Watts)
- 2) A component or technique that would replace the bulky, fragile, and power hungry thyatron that acted as the master timing control switch.



Modern Mallory "2006" Capacitor Discharge Ignition Components

Both solutions came along about the same time. Power transistors became available to the aerospace industry in 1954. These allowed the development of early push-pull switched mode power supplies whose output were way beyond what a mechanical power vibrator could deliver (up to 90 Watts initially). Complete transistor converters were available to the hobbyist in early 1958. So we can assume that prototype power transistors were available to industry in about 1955.

Early advertisement for a 90 Watt (pulsed) Hobbyist 12V to 450V DC Converter
From "QST" magazine January 1958
(Notice size reduction when compared to the 60 Watt Vibrapack)

The second critical breakthrough came with the invention of the Thyristor or Silicon Controlled Rectifier (SCR) by Bell Labs in 1957. General Electric quickly bought the rights for this promising technology and wasted no time in bringing it into production. The manufacture of solid state power rectifiers and transistors was already well underway, so, building an SCR using the existing production equipment was a slam-dunk. According to the GE SCR Handbook 1964 3rd edition, the model C35 had already been in the field since 1958.

SCR MANUAL

C35
(TYPE 2N681-2N692)
Medium Current
Silicon Controlled Rectifier
35 Amperes RMS Max.
Outline Drawing No. 5

- Broad Voltage Range—Up to 800V (440 Volt RMS Applications)
- Thermal Fatigue Free
- No Peak Forward Voltage Limitation
- Standard TO-48 Outline
- Designed to Meet MIL-S-19500/108A
- Backed by 6 Years of Design and Field Experience

Silicon Controlled Rectifier available to Industry and Military in 1958

With these new solid state components at hand Marion & 'Boot' Mallory were off and running. Their first beta-test race track CD ignition system was introduced in limited quantities in the fall of 1961. Their first after market production models did not reach distributors until 1964. It took 3 years of detailed development and waiting for the SCR market to settle down before deciding on a final production design. While the basic operating principles of a CD ignition circuit is straight forward getting a long-life circuit that will function well when exposed to the temperature, voltage, and vibration extremes is a different matter. At that time in our country's industrial heritage new products were not generally rushed, half-baked, to the re-sellers because of some imaginary dead-line imposed by the bean-counters in the marketing department.

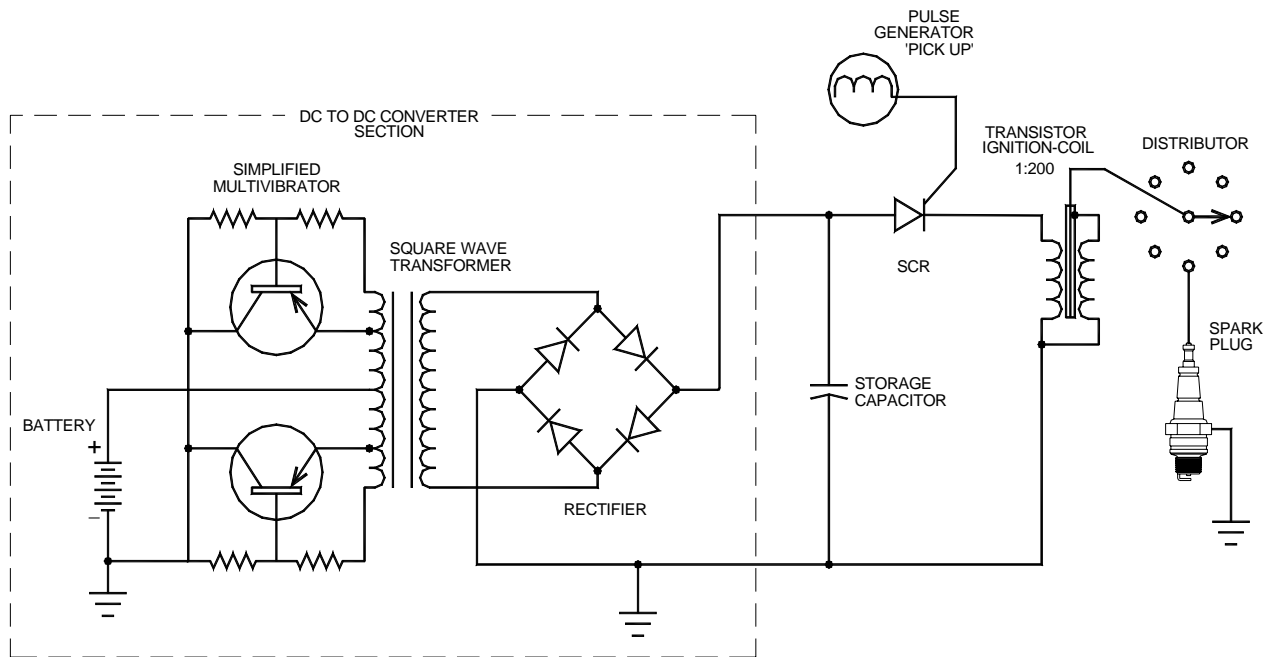

SIMPLIFIED SCHEMATIC OF CAPACITIVE DISCHARGE SYSTEM
 CICRA 1975 TO PRESENT
 (From Tektronix - Engine Analysis Measurements 1970)

So, in the timeframe of 1960 to 1970 where could Mr. Gray have gone when he needed some rare applied technical expertise on battery operated High Voltage pulse systems? The solution seems almost obvious.

We have no doubt that Mr. Gray and 'Boot' Mallory were on a first name basis. They may have already developed some kind of relationship while the company was still in Detroit, we don't know when they first got together. We do know that Mr. Gray was provided with some significant venture capital along with the fruits of 10 or so years of proprietary field tested solid state CD technology.

It has been pointed out, by knowledgeable sources, that all of the Mallory's after market ignition systems used power transistors for the 6-12V to 450V converter section. So, we wonder, why was Mr. Gray still using obsolete vibrator packs in 1973? 'Boot' would have certainly supplied Mr. Gray with the most modern equipment, along with the SCR and Ignition-Coil components in a small, self contained, custom engineered, and de-bugged package.

We suspect that 'Boot' did provide these complete transistorized CD systems and that Mr. Gray was eagerly looking forward to the reduced size, increased life time, and improved efficiencies that the new solid state devices promised. Especially after having to constantly fight with vibrators that kept burning out during his trial runs. But, Radiant Energy (RE) generation has its own special challenges to deal with. One major engineering issue is what to do with the Electro Magnetic Pulse (EMP) like effect that happens when a RE circuit reaches a certain power level. If all that excess energy is not properly shunted to the system common (hopefully after doing some serious work) it escapes from the circuit conductors to charge every metal object within 20' or so of the generator. A multitude of blue-white sparks will erupt from every metallic object in a room, due to the induced high voltage. This is certainly an interesting light-show, with the lights turned off, but devastating to any near by transistor or IC that has any amount of wire connected to it. Transistors and IC's that are stored in metalised protective bags or boxes seem to survive.

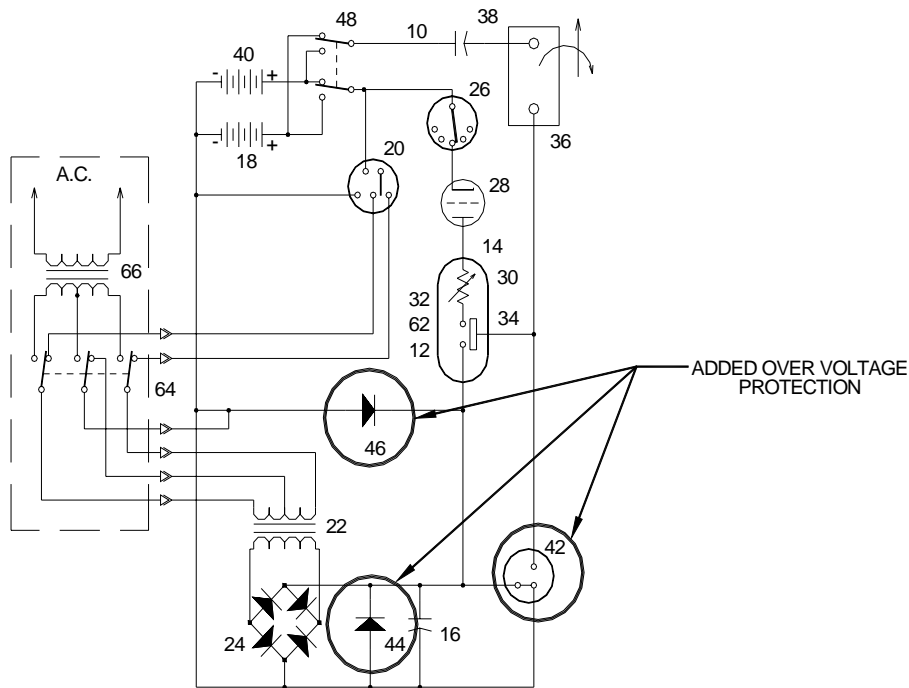

THE GRAY CIRCUIT PER PATENT 4,595,975
JUNE 17, 1986

If this was the case, then we can imagine how disappointed Mr. Gray might have felt when his new transistorized converters started to fail, perhaps even catastrophically. Fortunately, and **we really mean very fortunately**, the SCRs were able to survive the RE onslaught. Had this not been the case the EV Gray technology, because of the constant system failure, would have seriously fallen on its nose by 1965 and never have been able to produce the demonstrated power levels that we would so very much like to recreate. Transistors, fail because they are constructed with super thin base structures that are sensitive to moderate voltage differences. SCRs are constructed with thick silicon layers that are relatively more rugged. However, a poorly designed trigger circuit in an RE application will still destroy a heavy duty SCR, if proper gate transient protection methods are not employed. Because of this first hand experience Mr. Gray went on to install many over-voltage protection devices in his future circuits. This is very apparent in the design of the power supply shown in his Conversion Tube Patent #4,595,975.

It appears that Mr. Gray was forced to go back and use the failure prone obsolete vibrator packs that he started out with. According to the first patent these were used for the primary DC voltage conversion. We suspect that the engineers at Mallory were enlisted to help Mr. Gray marry the vibrator pack to the SCR system. The SCR addition did help solve the failure problem by reducing the arcing current across the vibrator contacts. This is not a straight forward interface and it requires some experienced electronic know-how. The challenge is balancing the limited current capacity of the vibrator to the low impedance of the SCR storage capacitor.

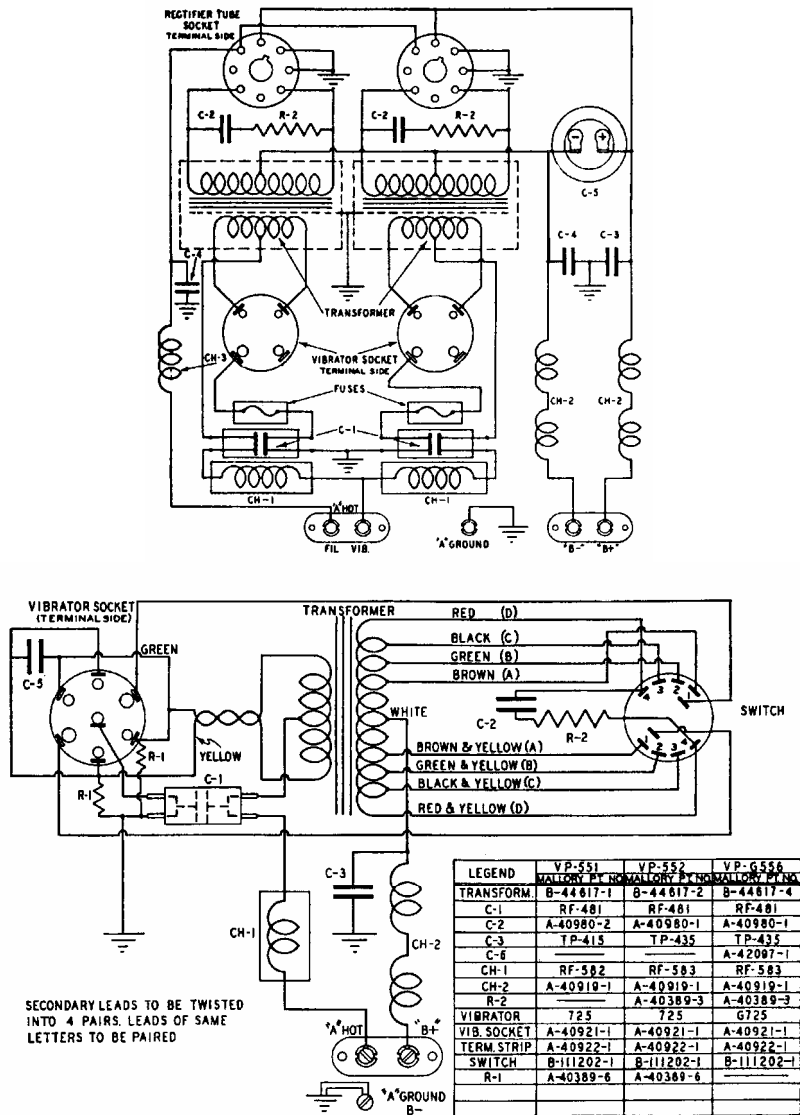
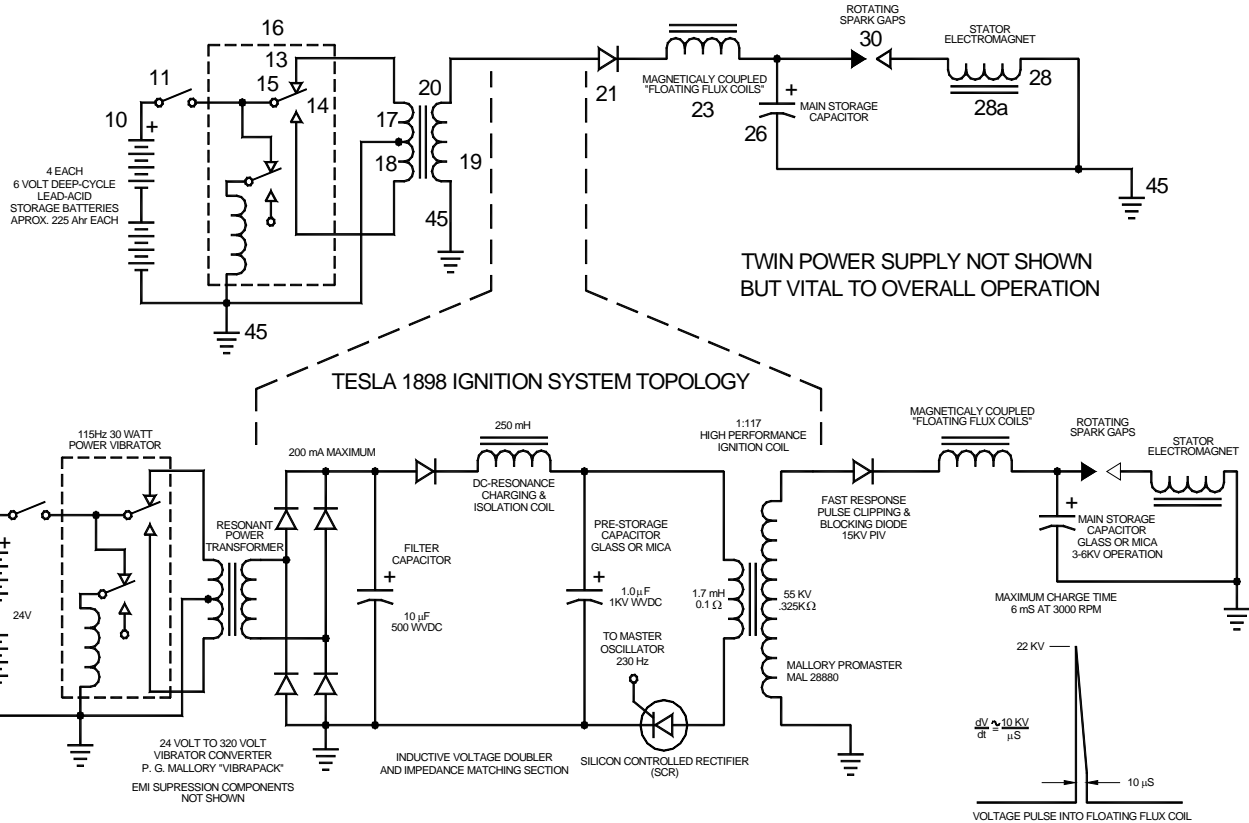

FIG. 28—SCHEMATIC WIRING DIAGRAM FOR VIBRAPACKS
Nos. VP-551, VP-552, VP-G556

Schematic Wiring Diagrams for two P.R. Mallory Vibrapacks
60 Watt model on the left – 30 Watt model on the right

Other researchers contend that Mr. Gray never intended to use transistors in the first place. This is because one RE theory states that the non-classical process begins in the minute arcs formed during the making and breaking of the vibrator contacts. This technical issue is still open for debate and experimental verification.



PROPOSED NON-DISCLOSED CAPACITIVE DISCHARGE SUB-SYSTEM IN EV GRAY CIRCUIT

However, we all agree that the SCR CD circuit is still a vital sub-system to the EV Gray technology, but it is not the whole story for a complete Over Unity (OU) process. We further believe that Mr. Gray didn't disclose the kernel of his "secret" to 'Boot' or any one else at the Mallory Electric Company. It would appear that 'Boot', because of his unique individualistic upbringing, respected Mr. Gray's right to his own creations. 'Boot' was obviously far sighted enough to see some greater business potential in this venture, not to mention a whole new class of future racing machines. One main reason for this enlightened attitude was that 'Boot' didn't have to contend with a short-sighted governing board of directors whose members were more worried about next quarters stock price than taking risky chances on age changing technologies.

The CD sub-system of the Gray motor was not disclosed in patent #3,890,548. Mr. Gray did mention the use of ignition coils in the patent text, but didn't show them in the schematic diagram. The simplest solution to help protect his "secret" was to just eliminate the CD sub-system from the schematic. Since Mr. Gray was only attempting to disclose a new type of pulse motor in this first patent. The omission of a "minor" power supply "feature" was not going to mean anything to the patent reviewers. But, the devil is in the details, especially when attempting to reconstruct this lost technology 30 years later.

There is a good possibility that Mr. Gray was returning a favor to 'Boot' by not disclosing the proprietary CD circuit designs. They very well could have had a gentlemen's agreement and a joint venture on this issue. 'Boot' didn't need to know Mr. Gray's Free Energy "Secret". His high margin piece of the action was locked in because each new EV Gray motor would need 18 or more complete CD power supplies, including the patented construction details of the Mallory ignition coils. Mr. Gray's success was going to be 'Boot' Mallory's success – BIG TIME. A classic win-win situation. It's no wonder that 'Boot' willingly made out checks to this unknown and un-educated inventor from California. While the P.R. Mallory Company was unknowingly going to reap some benefit from this breakthrough the Mallory Electric Company was going to hit the jackpot.

As a purely speculative observation, it may have been 'Boot' Mallory who clued Mr. Gray in on how to write patents and attempt to protect one's intellectual property from the big business lawyers. What to show and what not to show, what to draw and what not to draw and what to say the rest of the time. With this technology it was going to be a feeding frenzy as soon before the first beta-test hit the street and 'Boot' knew it. Mr. Gray probably received a life time of inside information on how to keep secrets, make money, and cover one's assets from a man who had been there and seen how big business really works.

We all know that Mr. Gray suffered a major setback when his research facility was raided in 1974 by the agents of the Los Angeles District Attorneys Office for suspected securities fraud. But, by 1977, as shown in the photo above, Mr. Gray had recovered enough to receive his first patent, build, debug, and demonstrate his second generation

motor. What is not generally known, in Free Energy circles, is that Mr. Gray suffered a far greater loss when 'Boot' Mallory was killed in a car wreck in 1978 at the age of 48. He was always known to be somewhat of a lead foot.

Gone was the financial, technical and more support. As far as we can observe it appears that the EV Gray motor didn't develop significantly much beyond the EMA6 model (above). The surviving Mallory women sold the company to Super Shops of Irvine, California in 1979. Mr. Gray continued to seek a proper level of investment capital so that he could control and manufacture his fuel-less motors in-house. He also improved on his popping-coil demonstration and updated it to a continuous process that hinted at anti-gravity possibilities, very impressive. It has also been rumored that Mr. Gray almost did collect enough money to begin production.

Unfortunately, we also know that ten years later Mr. Gray died under un-resolved circumstances in Sparks, NV in April, 1989. Sparks is just East of Reno, NV which is about 50 miles North of Carson City, NV. Some researchers contend that the main reason why Mr. Gray established one of his multiple laboratories in this town was because of the invaluable technical experience of some of the retired Mallory technicians still living in the area.



We have also been lead to believe that it was 'Boot' Mallory who made the first formal introductions between Mr. Gray and the alternate car inventor Mr. Paul M. Lewis, creator of the "Fascination". You can imagine the possible creative energy that might have flowed between these three unique individuals while they were sitting around the dinner table sharing a host of far-reaching dreams and schemes.

Today, the sold and re-sold fragments of the P.R. Mallory and the Mallory Electric Company have suffered, like so many U.S. businesses, from the now common and insidious blight of globalization. Both organizations are outsourcing their manufacturing operations to China, their engineering departments to India, and their R & D efforts to Canada.

In conclusion all we can say is that this saga is truly a vital lost opportunity for the world, they were so darn close. Had this story been different we most likely wouldn't be bankrupting our country in a vain attempt to secure oil reserves in Iraq. We could have easily had permanent colonies on Mars and not be worrying about the ongoing effects of Green House Gasses. This great country could have re-invested the trillions of our oil dollars into our own economy rather than providing excessively lush life styles for a few privileged Middle Eastern clan leaders.

Note: This document is one in a series produced by Mr. McKay as part of his investigation of the work of Edwin Gray senior and he invites readers to contact him if they have any constructive comments or queries concerning the work of Mr. Gray. Mr McKay's e-mail address is mmckay@tycoint.com

Mark McKay's investigation of Edwin Gray's Technology: Part 2

Taking a closer Look at the Demonstration Equipment October 24, 2006

This is the classic photo of E.V. Gray's "Popping Coil" Demonstration apparatus. This can be found on Peter Lindemann's web site. This photo was taken by Tom Valentine in 1973. Mr. Gray is the man in the center and Fritz Lens (his new father-in-law) is on the right. The man on the left is unidentified (most likely Richard Hackenburger VP of Engineering).



For years, about all one could say about this photo was that there was a fair amount of equipment involved in these demonstrations. The energy source appears to be a common large automotive 12 volt battery. Identifiable components are the custom made air transformer and the Triplet 630-A multimeter, all the rest of the technical detail is hidden by the black Plexiglas instrument boxes. By itself this photo does not yield much information.

In 2004 a former E.V. Gray investor came forth and presented Peter Lindemann and John Bedini with a period collection of historical snapshots. Five of these photos were of the same apparatus that was shown to Mr. Valentine in the above photo. The location was different, but the equipment and layout appears to be the same. It is assumed that these new investor photos were taken at Mr. Gray's shop in Van Nuys, CA. These photos were developed in January and June of 1974 so they could have been taken within a few months of the Valentine 1973 photo. By observing these photos some additional technical information about this novel technology can be extracted.

The Investor Photos:



Investor Photo #013C

Overall View

This is a nice shot of the whole demonstration apparatus from one end of the table showing the supply battery, two popping coils and an end view of the air transformer. Despite the limited focus, this photo shows that the popping coils are connected in parallel since the white leads on the left are both terminated on the negative terminal of the battery. Also connected to the battery is a component that appears to be an analog metering current shunt - a low value high current resistor device. However, there is no meter connected to this component as there would be in a normal application. This suggests that it is being used simply as a low value current limiting resistor. It is doubtful that this component was ever intended to be used in a metering capacity. Its output would have been a very short voltage pulse that could not be recorded or observed on any of the test instrumentation shown in any of these photos.

It is believed that the two black leads on the right of the air transformer are disconnected and hanging straight down to the floor. Compare this situation to the Tom Valentine photo where these heavy black leads are connected to two of the black boxes.

There appears to be four black wires connected to the right side of the electromagnets. The two larger black wires are thought to connect to the wiper of the DPST knife switch. It is not known for sure where the small remaining black wires connect, but most likely to an additional set of electromagnets parked under the air transformer as shown in photo #013B. If so, then there probably was an accompanying demonstration that showed what would happen if additional load was added to the circuit.



Investor Photo #012D

Popping a coil with the second demonstration setup on the "Right"

This photo is taken at the same location some time earlier where the circumstances were slightly different. The small white table and its attending equipment that is shown in the future June 74 photos are not present. This photo (Jan 74) was developed 6 months before Photo #013C. The equipment on the large table seems to be in the same relative positions. What this photo reveals is that there is a second "Popping Coil" demonstration taking place at the other end (right side) of the table.

It is proposed that this total assembly of "Black Boxes" (a dozen or more subsystems) actually supports two different and independent demonstrations, a "Popping Coil" demo on the left and another similar "Popping Coil" demo on the right. The photos available allow for a better technical analysis of the demonstration equipment on the left side of the table. It is unknown as to what the actual differences between these two demonstrations were, however it is apparent that the coils being popped have obvious size differences. In photo #012D the coil in mid air is about twice the size of the electromagnets shown at the other end of the table in photo #013C. The Tom Valentine photo shows a set of electromagnets (at rest in the lower right hand corner) that are at least four times the size of the coils used for the demonstration that was set up on the left side of the table. However, the launched coil shown above is not the same (being 50% smaller) as the coil shown in the Tom Valentine photograph, even though it is being powered by the same equipment.

It is thought that the demo on the right had something to do with a higher power level or a more advanced method of energy recovery. Most likely, the demo on the left was intended to make the initial technical introduction to the basic idea of a repulsion motor concept, while the demo on the right had some important engineering advancement to display.

Photo #012D is dark but it helps shows that the two white wires from the DPST knife switch for the left demo connect to the two equal size boxes in the middle of the table, one wire per box.



Investor Photo #013B
120VAC Power Source being explored

This June 1974 photo is a nice over view of the “left” demonstration equipment. The major issue here is the additional equipment on the small white table. Here we see some identifiable items, a neon transformer, a 2KW Variac autotransformer, a cassette tape recorder and a barrier type terminal strip. The question is: What is this extra stuff for?

It appears that this setup is a variation from the normal equipment demonstration as seen in the Tom Valentine photo. It seems that the Air Transformer is disconnected from the system and has been replaced by the power provided by the equipment on the white table. Most likely this was an attempt to demonstrate that AC line power could be converted to “Cold Electricity”. It is important to note the variations in this particular circuit layout as it provides some clues as to the function of the various Black Boxes.

First, notice that the two white wires that go to the DPST knife switch have now been connected to one terminal of the black box, while a red jumper connects to the white wires’ previous connection point. Compare this to how these white wires are connected in the Tom Valentine photo.

It is not all together clear how the Neon transformer and Autotransformer are connected but a standard approach would be to have the Variac control the input line voltage to the Neon transformer. This Variac has the ability to increase its output voltage by 25% above its input. If this Neon transformer were a common 15KV 30 mA unit then the RMS output voltage could have been adjusted to a maximum of 18 KV. This is comparable to the output of an auto ignition coil. The peak DC voltage potential would have been about 25KV. However it is unlikely they were operating at this high of voltage for very long because of the size, layout and construction of the temporary conductors.

Since a single pair of conductors (yellow and black jumpers) drop below the top of the white table it is proposed that there is a high voltage diode stack underneath the table on a shelf that is operating in half-wave mode. Had full-wave mode been used then four wires would be seen leaving the top of the table (which is still a possibility).

The utilization of DC pulses is very clear in the Gray motor patent. It has often been wondered why Mr. Gray didn’t use full-wave rectification in his power supply to take advantage of the increased efficiency. Apparently this equipment does not have a taste for straight DC voltage. This concept is reinforced by the use of the half-wave rectification power supply shown in photo #013B. This situation supports the idea that Mr. Gray may have had

capacitors connected in series, without equalization resistors, thus pulsating DC would have been needed to charge them.

Photo #013B shows the best view of the demonstration equipment for the "Right" demonstration. It seems to be composed of five Black boxes, two small ones, two large ones, and one small flat one. If a knife switch was used to launch the popping coil it is not visible in these photos. An air transformer seems to be missing from this equipment collection. However, consider the cylindrical object seen under the large table in photos #012D and #013D. This is about the size of a gallon paint can and has yellow tape on top. Three black wires (and possibly a fourth) can be seen leading to this device. It is proposed that this is the air transformer used for this equipment. It has a larger diameter (8") than the air transformer that is used for the "Left" demonstration (4"). It is believed that the automotive battery seen at the left end of the large table is the prime source of power for both demonstrations. A Triplet 630-A multimeter can be seen laying down on the far right of the table.

Examine the air transformer in its disconnected configuration. Notice how the two black conductors roll off the coil to the floor. This can only be achieved with two separate layers. The nearest conductor is part of the first layer. From this observation the relative polarity of the air transformer can be determined.

The core of the air transformer appears to be about 4" in diameter, when compared to the 2"x4" support blocks. It appears to be of a dual layer construction like one kind of pipe was slipped over another. The inner pipe resembles gray electrical PVC, but thinner (could be schedule 20 pipe). The outer pipe is a dark brown material that is not a common modern construction material. It is closer to an older fiber-composite material that was used for sewer pipe in the 50's. Why the need for two nested cores? Is the dielectric breakdown of the core that big of an issue for such a small air transformer? The insulation strength of the (assumed) spark plug wire is near 50KV and should be plenty for the operating voltages expected. In addition there appears to be a hefty layer of electrical black tape between the core and the heavy windings.

It has been proposed that the black tape covers a single layer of #16 AWG magnet wire that forms a winding 3-4 times longer than the observed spark plug wire "primaries". This feature (if it exists) is considered to be an additional energy recovery subsystem.



Investor Photo #013C
Group Photo Session

This photo is too fuzzy to extract much additional detail, (as compared to photo #013C) however the 35mm camera that is being held by the gentleman on the right is clear enough. Also, note the Flash Cube snapshot camera sitting beside the autotransformer. Cameras are in abundance in this portrait. This suggests that this particular collection of photos (June 74) were the result of a planned event where selected investors were allowed take all the snapshots they wanted. It is believed that this was a rare event. Therefore we can be assured that the equipment displayed at this time had been personally sanitized by Mr. Gray to insure that none of the essentials of his "Secret" would be disclosed.

The well dressed gentleman, on the left, appears to be holding another cassette tape recorder with a black plastic microphone being held in his fingers.



Investor Photo #013D

Count the Turns on the Air Transformer

This is about the best photo available showing the overall layout of both coil popping demonstrations. A lot of the essential details are hidden in this presentation but some of the subsystem interconnections can be determined.

The lower shelf of the white table displays what appears to be a HV "door knob" capacitor that is connected to Yellow and Black jumpers. It is more likely that this is a HV diode.

Note: This document is one in a series produced by Mr. McKay as part of his investigation of the work of Edwin Gray senior and he invites readers to contact him if they have any constructive comments or queries concerning the work of Mr. Gray. Mr McKay's e-mail address is mmckay@tycoint.com

Mark McKay's investigation of Edwin Gray's Technology: Part 3

Secrets of the EMA4 and EMA5 Control Commutators (Still Unresolved)

Mark McKay, PE

While the technical revelations provided by the disassembly of Mr. Gray's custom electromagnets is important, the observations collected from the EMA4 and EMA5 control commutators are even more interesting (and perplexing).

Prior to the recovery of the EMA4 & EMA5 it was thought that the attached white cylindrical device on the back end of the EMA6 was a simple rotary positional timing commutator device. According to patent 4,595,975 a commutator like device was included in the schematic diagram. It appeared to be some kind of mechanical rotary switch that controls timed pulses of power to flow through the anodes of the CSET. So when the patent and the photos are examined together the arrangement seems plausible.

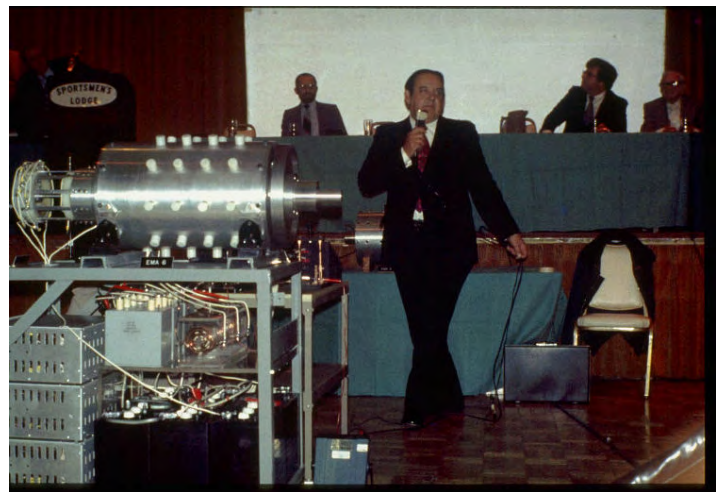
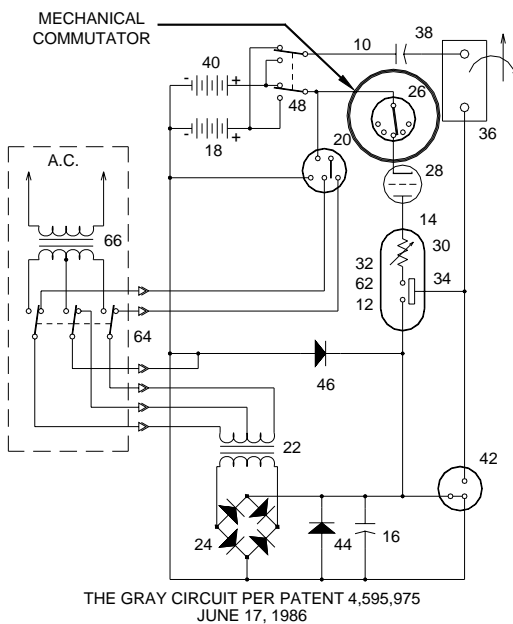

The EMA6 – with Control Commutator on extreme Left Stripped down EMA4 motor on back table

As it turns out the EMA4 and EMA5 motors revealed a much more complex component for researchers to consider. These commutators were constructed in such a way that they contained way more contacts than what would be needed for simple positional feedback. The units that came with each motor were designed to be pretty much the same, however they were wired differently. More control wires were utilized with the EMA5 than with the EMA4. This would be consistent with the fact the EMA4 only had one electromagnet pair to pulse while the EMA5 had three. The EMA5 commutator used 9 of its 15 contacts and was connected with 7 control wires. The EMA4 commutator also used 9 of its contacts but was only connected with 3 control wires.



EMA4 and EMA5 Motors at the time of recovery in 2000
With external Control Commutators mounted on the right

An examination for wear on the commutator contact surfaces, from possible arcing and heating, showed almost no signs of degradation. The conclusion reached from this observation was that whatever energy passed through these devices must have been at a very low level. This being at least two or three orders of magnitude less than what would be needed to pulse all the stator and rotor coils at once. Estimated classical current levels of less than 1 mA at 200 Volts have been proposed as being an upper limit. Mr. Wooten examined these motors from a mechanical point of view, using his professional expertise, and reported that each motor appeared to have logged at least several hundred hours of operation. Yet, you would never conclude that much use by looking at the contact surfaces alone. It is possible that the commutators may have been replaced, prior to being taken out of service, but that is a long shot.



Norman Wooten displaying the Non-Disclosed Complexities of the Timing Commutator from the EMA5 Gray motor at the 2001 KeelyNet Conference⁵ – Courtesy Dr. Peter Lindemann

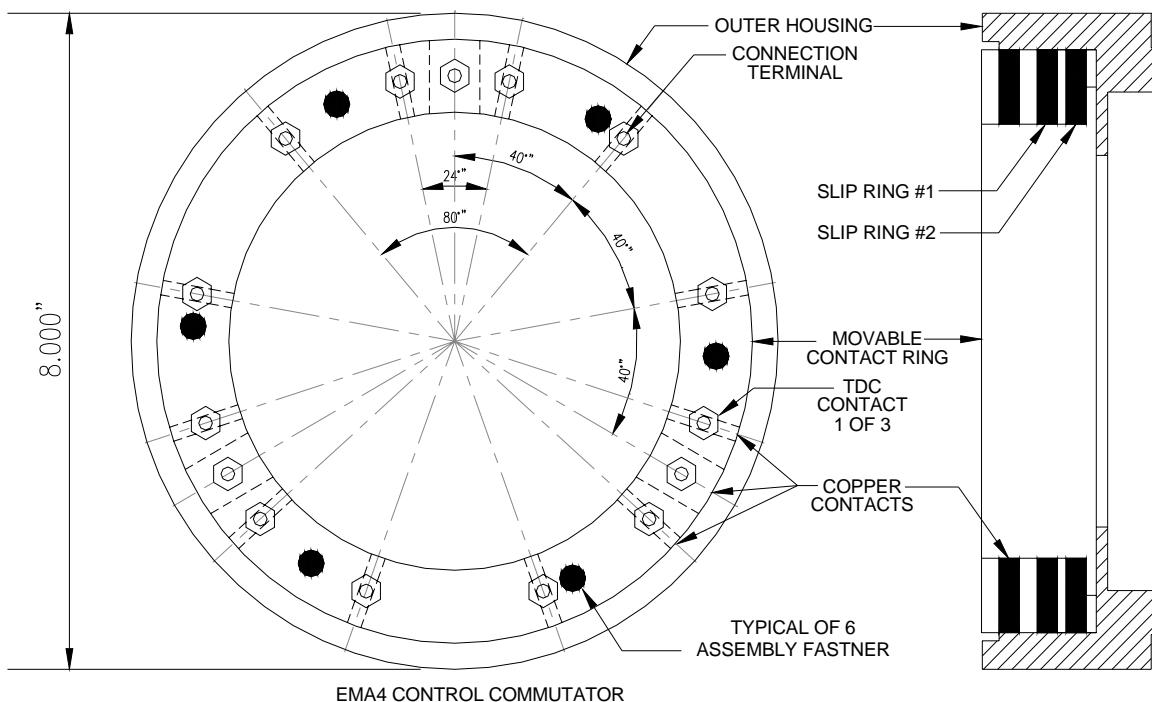

Observing the lack of wear, the new belief is that the commutators were providing both control timing and positional signals to Mr. Gray's energy converter. They were defiantly not directly switching the prime power that went to the stator and rotor coils. Further more, these timing signals were more complex than ever thought. In the recovered motors the commutator section and the motor electromagnets were wired independently.

Observing the lack of wear, the new belief is that the commutators were providing both control timing and positional signals to Mr. Gray's energy converter. They were defiantly not directly switching the prime power that went to the stator and rotor coils. Further more, these timing signals were more complex than ever thought. In the recovered motors the commutator section and the motor electromagnets were wired independently.

There are 15 contacts and two independent aluminum slip rings in each commutator subassembly. Three of these contacts are rectangular (1/4" x 3/4") copper bars that are three times wider than the remaining 1/4" diameter copper rod contacts. For both motors there appears to be two general timing patterns that emerge when looking at the angular spacing relationships of these contacts.

1.) The three large rectangular contacts and 6 of the smaller contacts are equally spaced 40° apart from each other around the circumference of the mounting ring. These would provide a continuous evenly spaced train set of short timing pulses, proportional to the speed of the motor, with every third pulse having three times the pulse width of the others. But, this is not what has been wired to go to the energy converter.

2.) There is also a repeated pattern with three clustered contacts. This group is composed of two small and the one large contact. These seem to be related to the "firing" of the electromagnets when the wiper is about 6° past TDC.

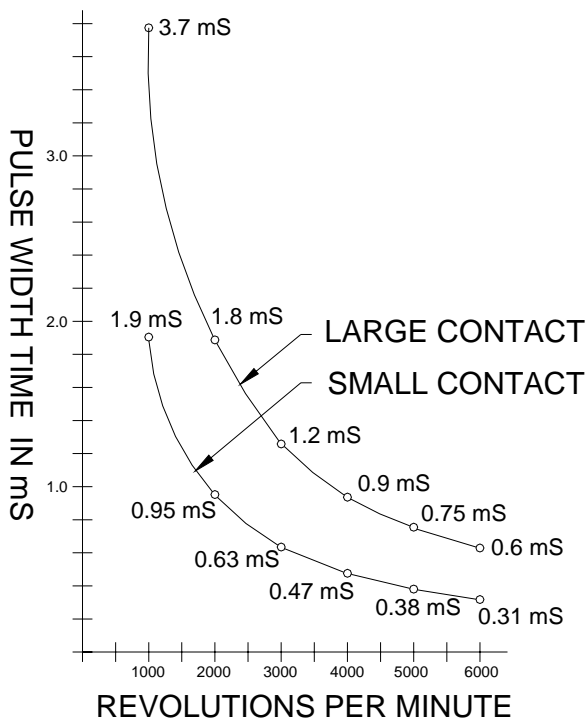
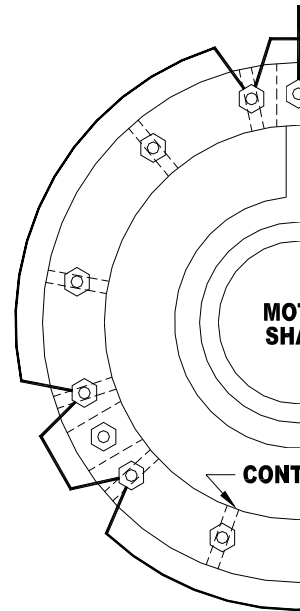

EMA4 COMMENTATOR EQUILIVANT CIRCUIT

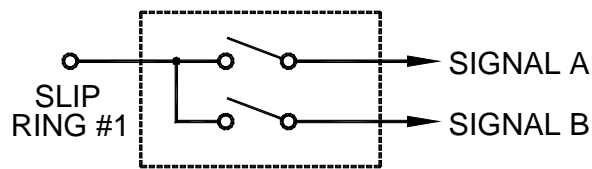

EMA5 COMMENTATOR EQUILIVANT CIRCUIT

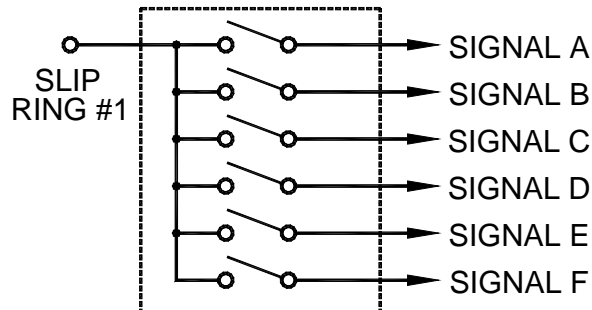

EMA4 COMMNETA

The rotary aluminum shaft wiper houses a spring loaded metallic "brush" that connects each contact to the slip ring in a sequential order. A second aluminum slip ring was installed, but was not utilized.

in the EMA4. If the slip ring were considered a circuit common then the timing pattern shown in Diagram 01 would be the result. Again not all of the contacts were used in either motor. This is indeed puzzling. Apparently different circuit configurations were being planned that might have used all these contacts.

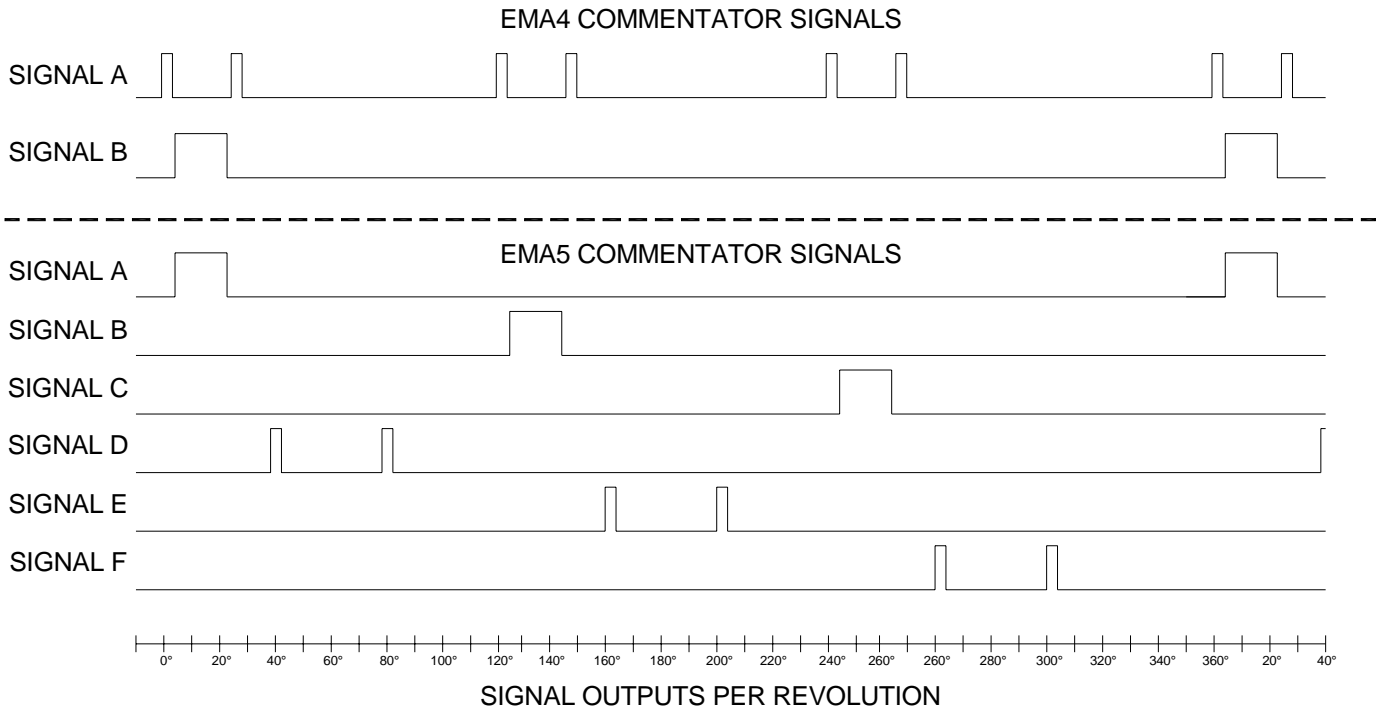

Timing Diagram 01 for Control Commutators for the EMA4 and EMA5 EV Gray Motors

Mr. Gray used a construction technique that is not generally seen in rotary equipment. There are three slip ring assemblies used in each of these two motors. One assembly is used in the commutator subassembly and has two slip rings sharing a common wiper. The other two slip ring assemblies are used to conduct pulse power through the rotor electromagnets. One is in front and the other is in the back of the motor. All three of these slip ring assemblies have an uncommon internal design. This is because the wiper and “brush” are rotating around the inside of a stationary slip ring. This is just the opposite to 98% of all other industrial machines in the world that use slip rings. Almost always, the slip rings are attached to the rotating shaft and the contacts or “brushes” are stationary. The obvious advantage of this common approach is that it allows the brushes to be easily replaced when they wear down. Another important advantage is that the “brushes” can easily accommodate some imperfections in the roundness of the slip rings that rub against them. This is because the brushes are mounted in spring loaded holders that allow them to move back and fourth. However, in Mr. Gray’s design, a brush or wiper replacement would require way more disassembly. Also, it doesn’t appear that this design could allow for nearly as much deviation from tolerance as the standard brush and slip ring arrangement can. We just don’t know what the application specific reason was that promoted this kind of solution; it certainly is not obvious from looking at the motors alone. Mr. Wooten contends that he could have designed a much better system to get the power into the rotor as well as several other major mechanical system improvements. So far no one has disputed his claim.

It is interesting to note that the Top Dead Center (TDC), the position where the electromagnets are squarely aligned with each other, takes place when the wiper is on the first small round contact in the cluster of three contacts, rather than the larger rectangular contact. Mr. Gray designated this location as 0°. It has been proposed that a certain amount of angular displacement is needed between opposing electromagnets when operating in the repulsion mode to insure that the generated forces are focused in one direction. Perhaps Mr. Gray determined that the optimum angle, for this size motor, is around 6°. The actual working angular displacement could be adjusted. Perhaps this was just a convenient reference point and had nothing to do with the function of the motor.

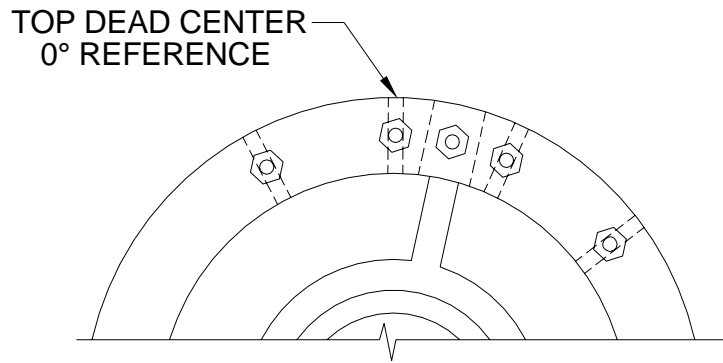

According to the jacket information the control conductors leading off from the commutators are rated at 25KV. Yet, their overall diameter is equivalent to common #14 AWG THHN household wire (.12" diameter). This is much smaller than typical electronic high voltage wire that has this kind of voltage rating. This wire was probably an expensive specialty cable in its time.

The small spacing between the wiper and the contacts in the clusters of three suggests that Mr. Gray didn't utilize any classical control voltages that had a differential greater than 200V. If classical electron flow were involved then voltages higher than this would have caused arcing at both the leading and trailing edges of the contacts as the wiper approached and receded from them. Again arcing was not observed. Then what was the purpose of the expensive high voltage cable? One proposal is that all of the control voltages connected to the commutators were elevated to some high value and their differences were less than 200 volts. This means that the whole commutator was "floating" at some high potential above ground. The overall nylon construction of the commutator assembly suggests that it could have easily supported this kind of high voltage operation (5KV to 20KV). The commutators on the EMA4, EMA5, and EMA6 are all mounted almost independently and external from the motor proper. This construction feature might imply a need for a high degree of isolation between the motor and the commutator. If so, then it is a distinct possibility that the commutator did operate at some high floating voltage.

The purpose of the various timing signals has been discussed within the Free Energy community but so far no general conclusions have been tendered that would explain how they affected the energy converter's circuit operation.

It appears that the energy converter needed at least two data streams, only a portion of which was the simple positional information. The rest of these short contact closures are assumed to be signals that could prepare the energy converter for its next pulse or to, perhaps, facilitate some kind of energy recovery cycle. There are four contacts between each TDC position; therefore there are provisions for as many as four changes of state per each power pulse. Not all of them were used at the time these motors were taken out of service, but they could have been.

Mr. Wooten, in his 2001 video, claims that the commutator compartments were filled with "Luberplate". This is the trade name for premium quality white lithium machine grease. Given that Mr. Gray didn't seem to spare any expense in the construction of this sub assembly, then what Norm could have observed might have been a special High Voltage Teflon/Silicon insulation compound that is used in the X-Ray business. This would have helped to extend the voltage differential of Mr. Gray's control signals to maybe 500 volts or so. However smearing insulation grease (or any kind of grease) on moving electrical contacts is a risky business. This is because it is difficult to build a system that will reliably wipe all the grease off the contacts just prior to contact and still provide a consistent low resistance connection.

Both commutators were built so that the contacts are housed in a movable nylon ring. This ring was installed in a larger hollowed out cylinder that acted as a housing so that the whole collection of 15 contacts could be adjusted together in relation to the shaft position. A machine set screw allowed for a wide range of timing angle adjustments (-40° to +40°). At a setting of -16°, according to notes written on the commutator, the pulse motor would run backwards. Probably not at full torque, but this shows that these motors were reversible.

After the recovery of the EMA4 and EMA5 motors the idea that Mr. Gray's energy converters were dirt simple has come to be questioned. The revised thought is that the Mr. Gray's low energy technology may have been simple, but the higher power technology now appears to be more complex.



EMA4 Rear View



EMA4 Front View

Photos of EMA4 and EMA5 motors are the courtesy of Mr. Norman Wooten via KeelyNet

Note: This document is one in a series produced by Mr. McKay as part of his investigation of the work of Edwin Gray senior and he invites readers to contact him if they have any constructive comments or queries concerning the work of Mr. Gray. Mr McKay's e-mail address is mmckay@tycoint.com

Mark McKay's investigation of Edwin Gray's Technology: Part 4

E. V. Gray Historical Series

Starting with the Start Motor

Mark McKay, PE

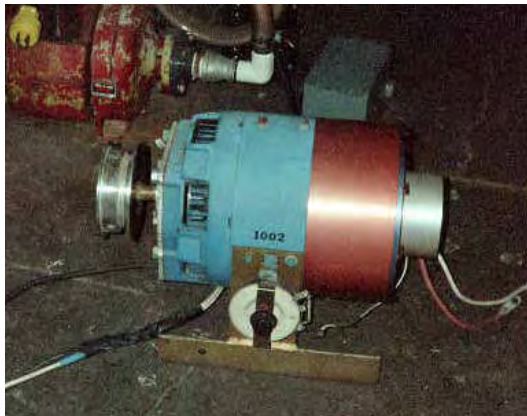

The Start Motor as Found in 2000

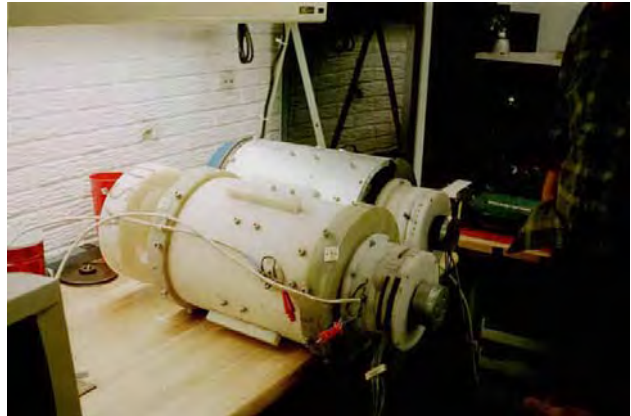

EMA4 and EMA5 Motors as Found in 2000

E. V. Gray once commented to John Bedini that his early free energy experiments were conducted with modified off the shelf industrial motors. It is assumed that when Mr. Gray's finally got adequate funding he went on to build a series of custom made motors that could take better advantage of the unique properties of his non-classical "Cold Electricity". These experimental designs were stamped with the model numbers EMA1 through EMA6. The EMA4-E2 and the EMA6 are his most well know constructions and are always associated with Mr. Gray's work. However, there were other transitional models built.

There may be one recovered example of a pre-EMA series motor that might have served as a functional test bed and very possibly an early investor demonstration model (circa 1963 to 1969).

In 2000 friends of Norm Wooten discovered two original EV Gray motors in a shop somewhere in Texas (most likely Grande Prairie, Texas where Mr. Gray had established a shop in 1986). These were the EMA4 and the EMA5 prototypes. Mr. Wooten acquired these pieces of history from the building land lord. He then took them to his shop where they were carefully disassembled. Later he produced a highly recommended video of his observations for the 2001 Keely conference in Florida. This informative tape is available from Clear-Tech at <http://www.free-energy.cc/index.html> in DVD and VHS formats. At the time the "Start Motor" was considered insignificant and therefore not looked at very closely.

After considerable mechanical analysis of the EMA4 and EMA5, Mr. Wooten came to the conclusion that this equipment contained no obvious free energy secrets. The vital energy converters that had powered these unique motors were not found. A few years later he decided to sell this collection.



Mr. Allan Francoeur of Penticton, BC, a long time free energy researcher and inventor, bought the entire lot for \$5,000 US in 2003. This package included the two prototype evaluation motors (EMA4 and EMA5), one of Mr. Gray's advanced coil popping setups (partial), and an 1940's modified non descript industrial motor. It was assumed, at the time, that this humble looking machine was a high voltage (5KV) generator used by Mr. Gray to charge up his storage capacitors for motor experiments. Later it was proposed that it was a DC motor used to start up Mr. Gray's large experimental motors, thus it finally became known as simply the "Start Motor". The Start Motor could also have been thought to be a dyno-motor. In this capacity it could have acted as a dynamic load to evaluate the performance of Mr. Gray's energy converters.

Custom Adapter Flange Added to Front of Motor

For a number of reasons this author contends that this piece of equipment was an actual working EV Gray pulse motor prior to the construction of the custom EMA models

Showmanship Tells All

Mr. Gray spent some serious money to have this simple motor dressed up way beyond any practical bench top need. If he wanted to conceal the details of its internal wiring from the occasional investor visit, then some heavy gauge sheet metal would have been a cost effective solution. Yet, this "Start Motor" was outfitted with a custom built three piece three color (Red, White, and Blue) anodized aluminum cowling set. The large red section was outfitted with a dozen small machined ventilation slots. These three pieces of non-functional eye candy probably cost him 50 times what the motor was worth, but may have been thought important enough, at the time, to help advance his early business development efforts.

As it turns out, the Start Motor is not a motor but a 5 KW DC exciter generator, circa 1940, used to provide field coil power for a larger generator (75KW to 150 KW). The 4-pole salient stator is outfitted with dual field coils that function in a compound wound configuration. It also has an independent set of slip rings that are connected to the armature coils and thus allow for external regulation. It looks odd, when compared to modern generators, because it has a commutator, like a DC motor, plus two additional slip rings like an AC motor. With the advent of solid state power rectifiers the slip rings and commutator bars in small generators have been completely eliminated, so you seldom (if ever) see this kind of construction. Externally mounted exciters have also been eliminated from the larger generator sets as well for much the same reasons. This same design was also called a "Three Wire Generator". These were used in the 20's to provide unbalanced three wire DC power for combination motor and lighting loads.

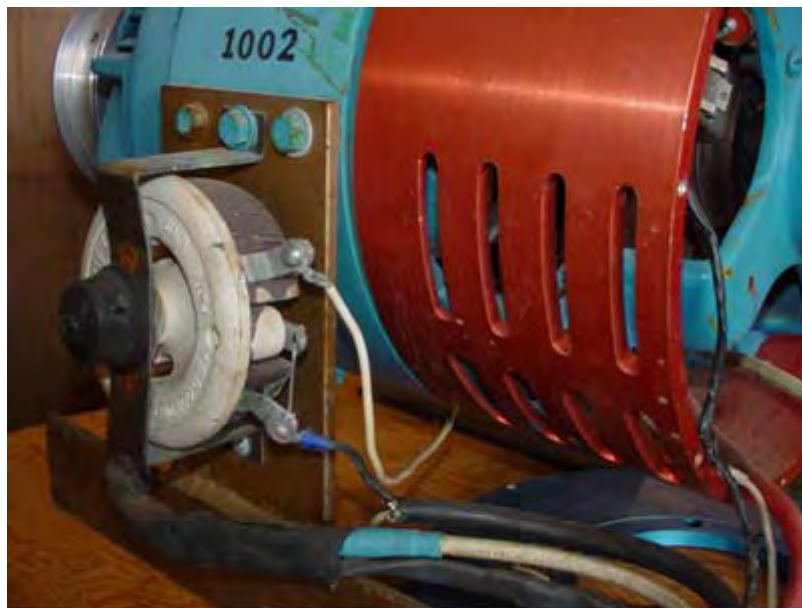

Side Mounted 200 Watt 2 Ohm Rheostat and Attached Cabling

Modification Details

Mr. Gray did a custom retro-fit to the front end of this motor. This modification was intended to be an adapter plate that would allow different flange mounted gear boxes to be attached. He also installed a simple magnetic probe in between two of the stator coils. The Start Motor was also reconfigured to receive its power through a #4 AWG cable (see the discussion about the cable used for the EMA4). There is a 2 Ohm 100 watt rheostat attached to the Start Motor's side that has one #14 AWG cable going to one slip ring and the other going elsewhere (not connected). The return large red cable (ground?) was connected directly to the generator frame once it got inside the case. Having prime power travel through the frame of a generator or motor is defiantly not a traditional electrical practice. Except for the rewiring of the stator coils, the probe, and the cowling the rest of the motor appears to be "stock". There were two suppressor capacitors associated with the slip rings that are similar to 50's automotive distributor condensers. These seemed to be original equipment and had not been replaced. One of the slip ring brushes appears to have been replaced once.



Back End View of the "Start Motor"

The recovery and simple analysis of the Start Motor only reinforces what has already been suspected about Mr. Gray's technology:

- 1.) There is no obvious over-unity process to be found in this rotary converter. (But that doesn't mean there are none)
- 2.) This device was designed to have all the stator and rotor coils pulsed at once. This is an operational feature that appears common in Mr. Gray's motor systems.
- 3.) Applied Voltage considerations: The effective classical voltage potential of the energy that passed through this device certainly did not exceed 600 volts and most likely did not get beyond 300 volts. Had Mr. Gray exceeded these parameters, given the age of these exciter generator windings, he would have risked an insulation failure. The typical classical operation of an exciter generator like this was typically 120 VDC at 50 Amps.

Interesting Thoughts:

Why was Mr. Gray still hanging on to this early prototype demonstration motor (for some 15 years) in the first place? Technically, it would appear that it was a relic from his development past, when compared to the advanced EMA4 and EMA5 evaluation motors. He certainly paid good money to have this equipment shipped from his Van Nuys, CA shop to Texas, so it must have been of some value. The "Start Motor" weighs about 75 lbs. The best speculation to date is that Mr. Gray was probably saving his more important milestone pieces of equipment for a future exhibit in some national technical museum. If this is partially true then the importance of the "Start Motor" should not be over looked.

The schematic for the "Start Motor" below is the author's best attempt, with out disassembling the motor completely, to show the modified internal wiring.



Added Magnetic Probe Next to Stator Winding
Assumed Used for Positional Feedback

Al Francoeur has taken very good care of this earliest surviving example of Mr. Gray's technology. It has been repaired, lubricated, cleaned up and now sports a new paint job. All that is needed is a reproduction EV Gray pulse energy converter to bring the "Start Motor" back to life.

If a breakthrough is ever re-discovered that unlocks the secrets of the methods used to create "Cold Electricity" then this modified exciter motor could well end up as a featured exhibit in the Smithsonian. This could have been what Mr. Gray intended all along.



Backend of the "Start Motor"



View of Compound Stator Coil and Slip Rings

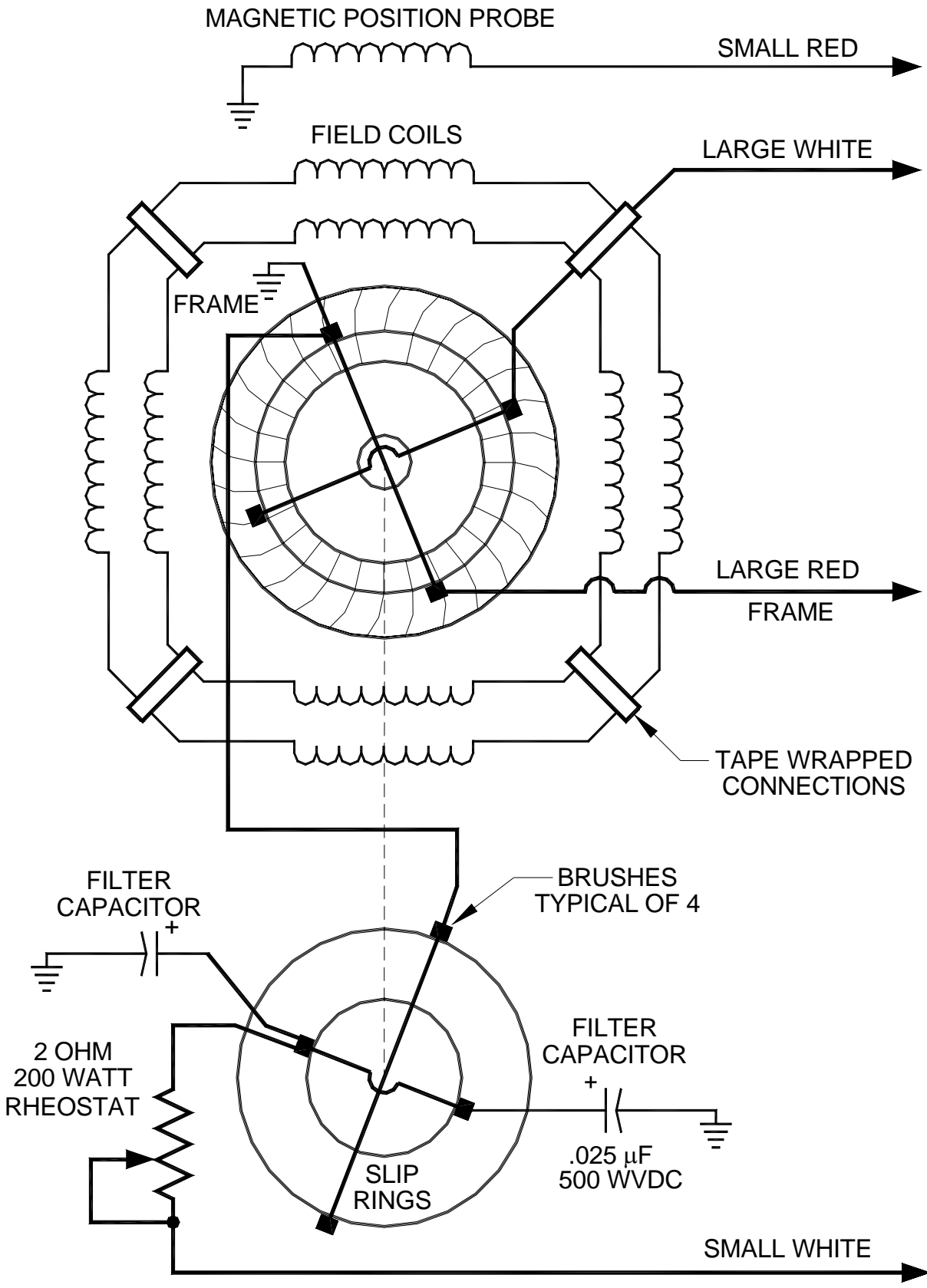

EV GRAY "START MOTOR" SCHEMATIC (PARTIAL)

Mark McKay's investigation of Edwin Gray's Technology: Part 5

A Compilation of e-mail correspondence from Mr. Tad Johnson and other fellow researches concerning experiments with the "ED Gray" energy conversion device

From: ☺ Tad Johnson <h2opowered@c...>

Subject: ERE Produced by Accident **Date:** Thu Feb 13, 2003 2:18 pm

(Tad Johnson) Have a look at the bottom of the page explaining the "problems" Jochen has found when firing this 300KV Marx generator. Looks to be what we are after since he cannot seem to eliminate it through grounding and other means. Also look at the total conduction times (64uS) with rise and fall times substantially lower possibly in the 5-10uS range.

<http://www.kronjaeger.com/hv/hv/pro/marx/index.html>

“The discharge seems to induce huge voltage transients in ground and/or mains leads. This has resulted in a burnt mains switch and a destroyed ground fault interrupter. Grounding the Marx generator separately and decoupling the charging voltage ground with a resistor helps somewhat. This may turn out to be a major problem, as the Marx generator naturally produces a huge voltage step with a rise-time probably in the microsecond range, and the subsequent discharge produces a similarly steep current pulse which might be kA or more.”

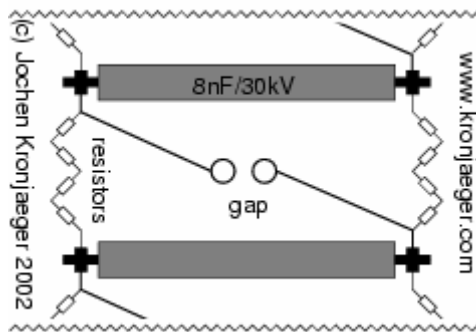

© 2000-2002 [Jochen Kronjaeger](http://www.kronjaeger.com)
hv@kronjaeger.com

Last modified: 2002-09-08 15:41:04

(Tim Martin) Do you have a plan to allow for easily adjusting the frequency of the impulses? I think it will be important to precisely tune the device so as to discern specific effects.

(Tad Johnson) The frequency is adjustable to a degree through adjustment of the spark gap distance and cap size. The caps I am using are 500pF so frequency should be in the KHz range depending on how much amperage the power supply is charging the stack with. Just got the HV resistors today. All I have left to do is build the CSET and figure out the charging circuit. Hydrogen or magnetically quenched gap on the output might be added later for even higher frequency and more protection against current reversals.

Subject: folder added Hi folks, **Date:** Sat Feb 15, 2003 11:52 am

(Jani V.) I thought you might like to see my version on Ed Gray's circuit In folder "romisrom" I just created, are some pictures of it, I will add complete schematic with component data as soon as I'm able to draw it...

Tad, I hope from picture "convtube" you will find some hints for your CSET. -Jani-

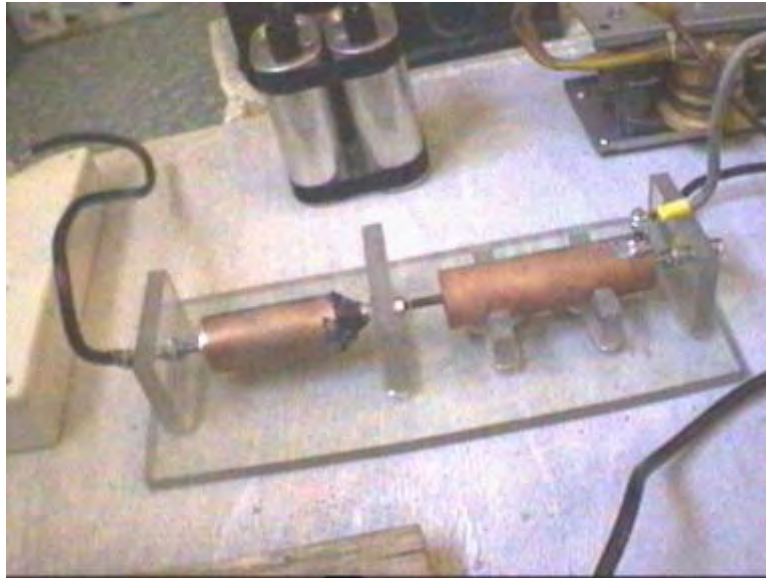

Subject: CSET design **Date:** Sun Feb 16, 2003 8:28 pm

(Tad Johnson) Thanks for the info. I was going to built it similarly although I was going to use 1.250" acrylic I have already to center the copper pipe. I have some new info on my power supply I will post soon. Looks like the rise time will be ~10nS with a pulse width of 50uS and a fall time of 40uS without a tailbiter circuit or resistive load of about .10hm to sharpen the fall time. I may add this later. Frequency should be about 25Khz as is.

Subject: Tesla/Gray device update **Date:** Thu Feb 27, 2003 7:08 pm

(Tad Johnson) My Gray device is now operational although I have foolishly fried a couple of neon sign transformers in the process of trying to loop the collection grid energy back to the power supply without some form of isolation circuitry. It appears I am now at the point that Gary Magratten was when trying to deal with a large pulse of energy and then measure it. Current circuit parameters are:

2000VAC @ 19.2Khz @ 20mA into a 12KV/40mA/100nS full wave bridge into a 2 stage marx generator using 400pF/ 30KV ceramic "doorknob" caps into a magnetically quenched spark gap using needle points of brass into the CSET of stainless steel balls on threaded brass rods. Collection grid is 316 stainless 2" diameter tube.

Total output pulse is 54uS wide with ~10nS rise and ~42nS fall.

I am thinking of running the output energy in the secondary of a 3KV microwave transformer to power a lower voltage load although I am not sure how the transformer secondary will handle this input, especially considering the frequency. Another option would be to increase cap size on the marx generator portion of the circuit to lower the frequency to something around 60-120Hz and then use it in a more conventional form.

Pictures and schematics to come soon. Any ideas are much appreciated.

Tad

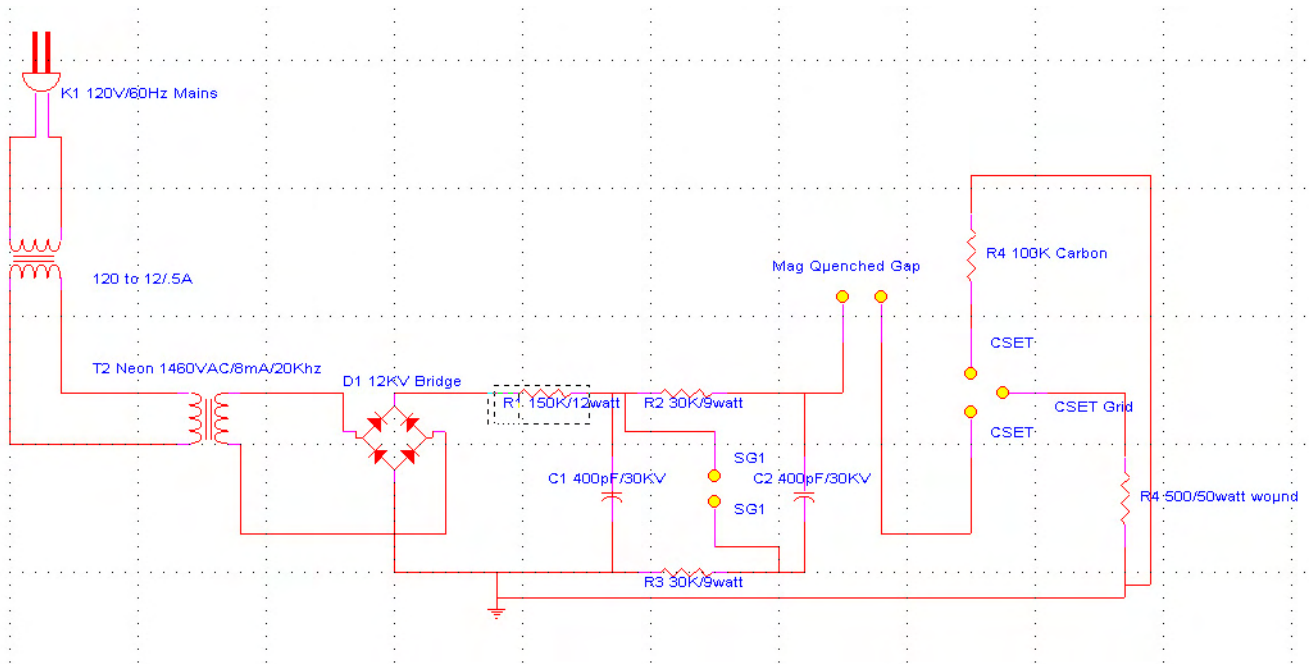
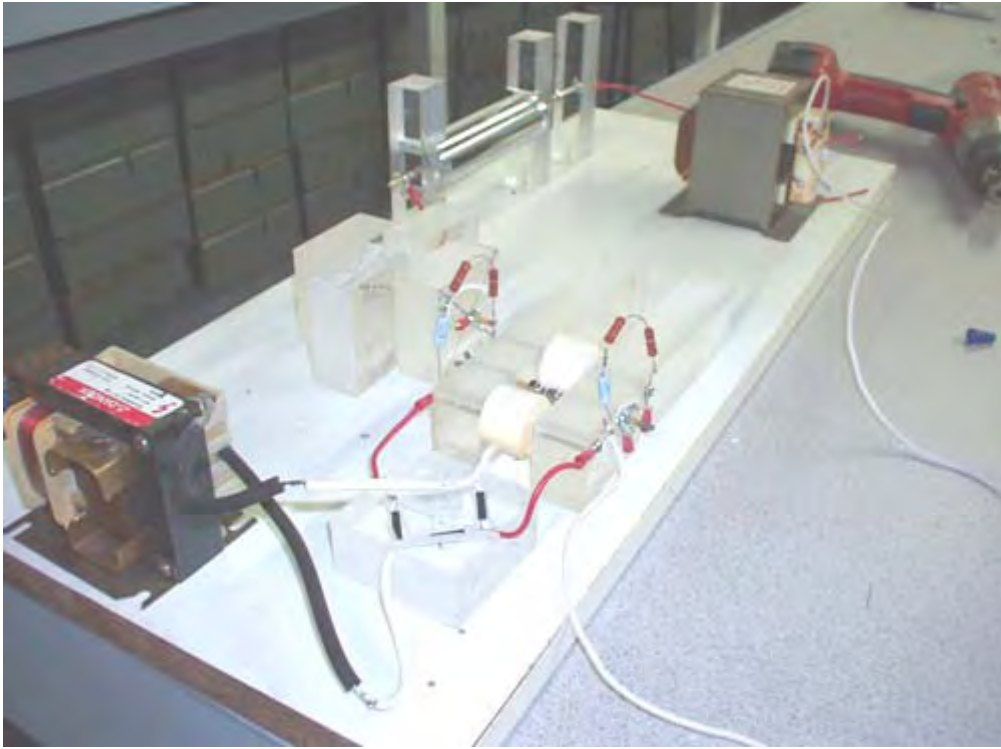

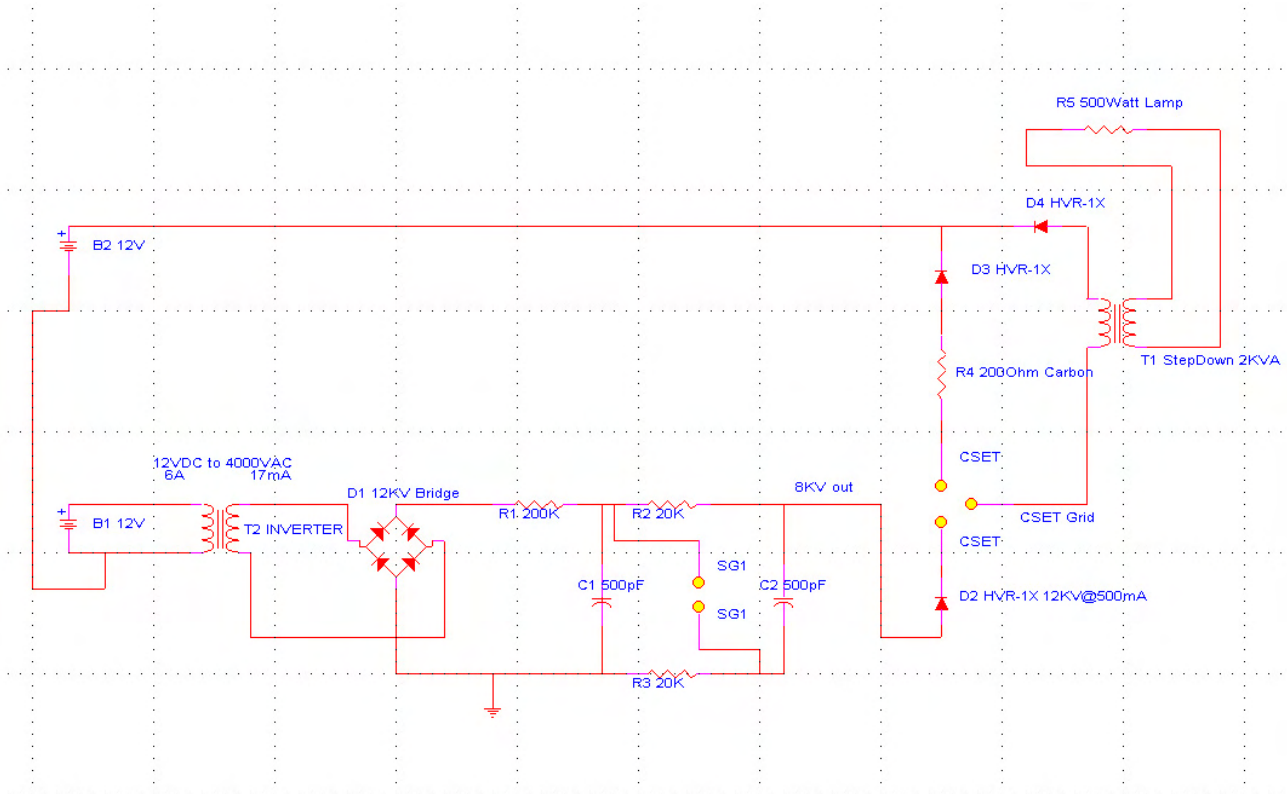

Date: Fri Feb 28, 2003 8:25 pm

(Tim Martin) I have a few questions.

Is it possible to safely measure the voltage and frequency of the CSET output?

(Tad Johnson) Yes, I got the data below by making a 50Megaohm resistor to measure it, although I am reluctant to hook up the 3500 dollar scope to it as of yet. I get more guts to do so after I check the warranty info on it. All data thus far was taken on a true RMS LCR meter.

What is the AC current draw of the neon sign transformer? (Tim Martin)

Should be 1.5 Amp per the specs. But I will check it with my true RMS power-meter(5amp max on the meter).

(Tim Martin) Would it be possible to dump the CSET output into a large lead acid storage battery?

(Tad Johnson) Yes, although I am told it will "cold boil" at that voltage. Seems to be hard on the battery but I don't have much knowledge on it. I would like to step the voltage down before connecting it to the battery to avoid premature failure.

(Tim Martin) Would the neon sign transformer work properly if connected to a small >DC/AC inverter on the 12 volt battery?

(Tad Johnson) Should.

Subject: Gray Circuit Images **Date:** Sat Mar 1, 2003 10:19 pm

(Tad Johnson) New images uploaded showing the Gray circuit running after being tuned. Having issues with long runs because the resistors are not rated for more than 10watt on the Marx generator, they start to get a bit hot. Images show a 120VAC/60HZ/1.5A neon transformer powering it since my two other 12VDC inverters were smoked due to bad judgment. No connection to the CSET grid was present during this test run since I was mostly tuning the Marx stack to the 120V neon supply. Frequency was .5-1Khz on this test.

New power supply got here today so I will try the 12VDC version charging the Marx stack at higher frequencies (20Khz).

Flash on the camera makes it hard to see arc across gaps, but it is there.

Total cost of the entire device is now about \$145 American dollars.

Subject: Re: [ElectroRadiantResearch] Re: Gray Circuit Images **Date:** Sun Mar 2, 2003 4:36 pm

(Tim Martin) I noticed in your pictures that you do not have a large high voltage air core as Gray and Magratten used in their circuits. Is this un-necessary?

(Tad Johnson) I am told the air core was a step down to run 120VAC/60HZ lamps and other resistive loads since resistive loads don't care about frequency. I haven't built an air core step down yet, but I might if I can't get a motor built soon.

(Tim Martin) Also, what did you say the clear "Plexiglas" material is? Real Plexiglas(tm) in those dimensions is fairly costly.

(Tad Johnson) Acrylic. Resists about 50KV in that dimension 1-1/8" thick. Very inexpensive. 1.5'X 1.5X square is 20 dollars. I used about half of one.

Subject: Grid Energy **Date:** Sun Mar 2, 2003 11:02 pm

(Tad Johnson) Interesting findings after running the Gray circuit for a couple hours:

ERE does NOT manifest if there is no resistor on the spark gap end of the CSET. Repeat ZERO POWER if no resistor in place. The more resistance, the more the effect appears to manifest.

With 300 Ohm or more of resistance the grid starts to put off a FRIGHTENING amount of power. Enough to smoke a 50watt, 500 ohm resistor in less than 30 seconds. My input was 12 watts total from the wall. Output from the CSET grid is UNMEASURABLE. Grounding is also becoming an issue since I cannot run the end of the CSET back to ground with a resistor in between. Also, the energy coming off the grid appears to be harmful even with fast rise and fall times contrary to other information out there.

Anyone have any bright ideas on measuring this high amperage, high voltage energy I would be very happy. We need accurate wattage out at this point. I feel confident already with my input measurements.

Subject: Re: [ElectroRadiantResearch] Re: Grid Energy **Date:** Mon Mar 3, 2003 11:05 am

(Tim Martin) It sounds as though Lindemann was correct in saying that one of the problems Gray had was dealing with the abundance of power.

(Tad Johnson) Yes, but we will see how much power. This is what I am after. If it is possible for a small 12 watt power supply to see a gain of at least twice that, then making the circuit for the application I am interested in will be easy (small motive power, scooter, etc.).

(Tim Martin) Do you think the CSET output is behaving different than "normal" electricity? What I am curious about is your statement regarding additional resistance increasing the effect.

(Tad Johnson) It appears as though there MUST be resistance at the end of the CSET in order for the CSET grid to make power. this appears to be the "bunching up" effect Lindemann was talking about, and that Tesla had experienced. It may be that when this HV pulse hits the resistance is like it hits a brick wall and explodes outward into the grid (path of least resistance).

(Tim Martin) Also, I believe that the frequency will govern whether or not the effect is harmful. Be careful!

(Tad Johnson) I'm being as careful as I can, but I have already had one small incident.

(Tim Martin) Another thing you might try is placing a normal 100 watt incandescent bulb on the output of the CSET without closing the circuit. Single wire power transmission is a related phenomenon.

(Tad Johnson) Yes, this works with a neon bulb, I've already run neon bulbs off the grid energy. they glow beautifully to full brightness.

Subject: Fwd: Re: [alfenergy] Grid Energy **Date:** Sun Mar 2, 2003 11:35 pm

(Willard)I can suggest putting a string of light bulbs together in series as a load. 5 bulbs of 100 watts each for instance.

(Tad Johnson) I will try that although I really need to somehow get an amp meter on it and the scope. I had to drop the voltage down from 2920 to 1460 just so I could lessen the effect enough to work with the components I am using without it destroying them. Meter overloads when trying to measure grid voltage on the doubled setting from the Marx generator. I am using a 100Megaohm, 100watt HV probe which should be more than sufficient for these voltages. Very strange.

Subject: Re: [alfenergy] magnetic quenched gap **Date:** Tue Mar 4, 2003 11:35 am

(Peer) The magnetic quenched gap is necessary to prevent continuously arcing. Is this right?

(Tad Johnson) No, it helps quench the arc, and bring the fall times back to something more normal. The waveform as per calculations is ~10nS rise, 50uS wide, with a long fall time, this is how Marx generators work. To bring the fall time back into ~20nS range we need to clip the end of the pulse. You can do this by killing the arc prematurely or you can put a low resistance load on the output of the spark gap (tail-biter circuit), or you can do both. My goal was ~10nS rise, 20uS pulse, ~20nS fall, with a pause of 500uS between pulses.

Subject: Re: [alfenergy] for Tad **Date:** Wed Mar 5, 2003 11:44 am

(Unknown Member) I'm trying to rebuild your circuit in order to better understand the working of the CSET. The original circuit built by Gray himself had a powerful input. Heavy batteries were used to power the circuit. You only use a small current und a much higher resistor at the CSET.

(Tad Johnson) Yes, my idea is to keep the power usage as low as possible but still see the effect. And I have truly seen it with a 9-12 watt power supply, so it IS there. I am now lighting neon bulbs from the grid energy alone, this should not be possible since it would mean an energy gain of at least 100%, or an additional 9 watts to make a total of 18watts for the entire circuit.

<http://www.amazing1.com/voltage.htm>

At the bottom of the page you will see the power supply I am currently using (MINIMAX2)

ATTENTION! High Voltage Experimenters
High Voltage Transformers

Low cost thumb sized modules may be battery powered and used for experimental research in: Plasma Guns, Shock Wands, Anti-Gravity, Hovercraft, Tesla Coils, Ion Guns, Force Fields, Electrical Pyrotechnics, Stun Guns, Etc..



- MINIMAX5** - 7000 Volt With IOG9 Plans.....\$29.95
- MINIMAX4** - 4000 Volt With IOG9 Plans.....\$19.95
- MINIMAX3** - 3000 Volt With IOG9 Plans.....\$17.95
- MINIMAX2** - 2000 Volt With IOG9 Plans.....\$14.95
- MINIMAX1** - 1000 Volt.....\$9.95

Bag of five 2 to 3000 volt units-some requiring minor repair, others more.

MINIBAG1 - Includes Basic Schematic.....\$19.95

(Unknown Member) I try to copy your circuit, using a medium size 6,5kV HeNe-LASER supply.

The output (grid-power) I get, is however tiny small.

(Tad Johnson) That's fine, my supply I use now is only 1460V @ 8mA!! But this voltage is doubled in the Marx generator. The Marx generator is used instead of the large capacitor and vacuum tube switch in the Gray patents. This eliminates the need for expensive and complicated switching techniques since the Marx generator switches on in less than 50ns and off in that

same amount of time unless you are running larger capacitors. 400pF caps @ 1460V @ 8mA gives me 500HZ. But 1900pF in that same supply only gives me about 1-2HZ, but much higher amperage pulse when the gap fires. If more amperage in the power supply (like 20mA) then this rate would obviously be much higher and much more controllable.

<http://home.earthlink.net/~jimlux/hv/marx.htm> [Appendix 1]

<http://members.tm.net/lapointe/MarxMain.html> [Appendix 2]

<http://www.kronjaeger.com/hv/hv/src/marx/index.html> [Appendix 3]

(Tad Johnson) The capacitors come from:

<http://www.alltronics.com/capacito.htm>

The 400pF 30KV ones are US \$12.50 each. The 6.5KV 1500pF are 99 cents each. The cheaper ones work just as well if not better! If you really want a big power pulse buy the 14uF, 20KV, 2800 joule cap!



CERAMIC HI-VOLTAGE TRANSMITTING CAP

400pF @ 30KV, TC N4700. Made by TDK.

20P007 \$12.50



SANGAMO ENERGY DISCHARGE CAPACITOR

14 uF 20KV 2800 Joule 14" x 8" x 24" --- Mineral oil filled

20P002 \$250.00

(Unknown Member) Maybe there is a secret I have not seen yet. My CSET is not a pipe, but a round cage made by copper wire soldered together. If a measurable radiant energy is made, this one I guess should be noticed by the small CSET grid I have.

(Tad Johnson) You WILL see energy on that grid regardless of it's design. I am using a stainless tube, but any copper, aluminum or anything else should work also. Multiple layers of different metals (copper inside, aluminum outside should increase power as well). Also, move the CSET spark gap into the tube like Skip said. I should have done this as well, but I was lazy. This should maximize the energy on the grid. Use a couple neon lamps to run off the grid. 220VAC @ 10mA is what my bulbs are, I use two in series and they light up to full brightness off the grid energy alone. One lead to grid, one to ground. They light to half brightness just touching the grid and not grounded. I am trying to figure out what I was doing when I ran the 50watt resistor across the grid output in order to get it as hot as it was getting. This circuit grid output varies greatly depending on how it is tuned so there are many things to test still.

I really want to try a flyback supply soon though.

<http://www.electronicasic.com/fly.htm>



(Unknown Member) Maybe my quenched spark gap is not working. How is yours built up?

(Tad Johnson) I used a block of plastic on both sides and used a Forstner bit (1/2") to core a hole in the plastic, then I used glue to glue the ceramic magnet into the hole on both pieces of plastic. Then I used a router to make a slot so I could adjust the magnet distance from the gap electrodes. The magnets TWIST the arc and cut it off early, This gives us a faster fall time.

(Unknown Member) Have you enclosed the R4 inside the CSET tube or outside? Is it a high voltage type or a normal one?

(Tad Johnson) Outside and it is a normal 10K, 3 watt resistor, made by Panasonic, ordered from Digikey. The same resistors are used in the Marx stack. I have also tried a HVR-1X, 12KV/550mA diode (THV512T is new part number). This works well also.

<http://www.electronicasic.com/diode.htm>

POWER DIODES (Use in MICROWAVE OVEN)



A - 1083

BUY **THV512T** 12KV - 550mA **\$3.20 each**

Replacement For : HVR-1X-3 12KV - 550mA
HVR-1X-4 9KV - 550mA

Other diodes I bought were VG3, VG6 and VG12 from

<http://www.amazing1.com/parts.htm>

VG22	22KV HV Diode For KILOVOLT MAGNIFIERS	\$3.95
VG4	3KV HV Diode - Used LGU4, IOG3, etc.	\$1.95

[Apparently out of Stock on the VG3, VG6, and VG12 on 5/4/03]

Subject: Gray Circuit Modifications **Date:** Wed Mar 5, 2003 11:18 pm

(Tad Johnson) I finished my circuit modifications as per suggestions. I tripled the capacitance in the Marx bank, installed the CSET gap in the center of the collection grid and added a 25nF cap on the output of the CSET grid in line with the load. The lamps glow at least as twice as bright as they did before. But what is really exciting to me was that I was going to work on the Marx gap so I went to short the cap bank. At the instant I shorted this bank of caps I felt the "wave of energy" which actually pushed my shirt in the direction of the blast.

Has anyone else seen this when discharging a cap bank and being of close proximity? Very strange anomaly. Makes me believe that Tesla must have been working with much higher voltage and much higher capacity than this circuit in order to feel this wave constantly at each gap firing. This is obviously what we are looking to reproduce.

Subject: Re: [alfenergy] Magnetic Quenched Gap **Date:** Thu Mar 6, 2003 9:16 am

(Alan Francoeur) I have tested the function of a magnetic quenched gap. I used a Marx generator to create short HV pulses. The spark gap was simple two ends of a copper wire facing each other with a distance of about 2 mm. I used a vice and put a strong Neodymium magnet at each side of the vise jaw. The gap between the two magnets was about 17 mm. (The magnets were attracting each other) the arrangement was so that you could easily remove the vice with magnets without changing the spark gap.

Without magnets an arc occurred many times after a spark and the frequency of the spark was changing all times and there was a small interval without a spark, partially. From that view I can conclude the spark gap without magnet is not so well functioning because of the lower spark frequency and the occurring arcs.

(Tad Johnson) Yes, I have found this myself as well. This is why I like the magnetic gap so much.

(Alan Francoeur) With the magnets, the spark's frequency was higher, and there was no standing arc at all. Each time an arc liked to occur the arc got blown out like a candle in the wind.

When I was connecting a small (8 Watt) neon-bulb between the vice ,which was made of steel and somehow served as grid, and ground the neon-light lit weekly and the ark frequency changed a bit also the ark noise changed! And this although there is no galvanic contact between the Marx generator and the neon-bulb.

(Tad Johnson) I don't understand why frequency changes when you connect a load to the grid, but I have seen this as well.

(Alan Francoeur) But I also measured the current flowing back to ground after the mentioned spark gap. This was done by a 50 Ohm resistor a HV-probe and an oscilloscope.

(Tad Johnson) I am making a new HV probe, 1GOhm will be the size. A bit high, but I have many problems with the 100MOhm one I now use.

(Alan Francoeur) Without magnets: the time duration of the spark could be hardly measured but seemed to be >500 ns.

With magnets: the time duration of the spark was definitely shorter and the picture on the scope was more clear. The time duration was 100 us to 200 ns.

(Tad Johnson) Great! This is what we are after.

(Alan Francoeur) In both cases, you see a positive high voltage pulse that exceeds the capacity of the screen of the scope. Then a small negative pulse, like the half of a sine wave, follows. After that there are fast oscillations. Maybe this picture does not show the true current flow, because of parasitic capacities of the used resistor.

(Tad Johnson) The ringing is what has been messing my frequency counter up I think. I might not be getting the correct frequency of pulses measured. Inductors can be used in place of the resistors to reduce loss, although the output will obviously be different and need to be rectified or sharpened up.

(Alan Francoeur) Another investigation was, that using no magnet, a multi-discharge could occur (many tiny discharges). With magnet there was always one discharge. Maybe you have the same experience.

(Tad Johnson) Yes, exactly. This is why Tesla also used these magnets around the gap. He was trying for a smaller and tighter discharge of energy.

(Alan Francoeur) Tad, have you tried to put magnets inside the gray tube? Therefore you would not need to have a separate spark gap and maybe more power inside the Gray tube.

(Tad Johnson) I have not tried this yet, but I can try it soon.

Subject: Progress **Date:** Thu Mar 13, 2003 10:42 pm

(Tad Johnson) No progress on the Gray circuit this week as I have been working on getting a lathe to make parts and do better quality work so I have not been financially able to buy the HV resistor for measurement nor the Thyatron, or spark tubes.

I pulled my Hydrogen combustion enhancement device out of the shop since fuel prices are getting ridiculous. Car already gets 33mpg, but 38-40 would be better.

I will put pictures of it when I get it running again.

I will be working on the Gray circuit again within a week or two though. Stay tuned,

Subject: Re: [ElectroRadiantResearch] Success ??? **Date:** Fri Mar 21, 2003 9:17 pm

(Jani V.) Last weekend I finally got a chance to test my Ed Gray machine and I think the Electro-Radiant-Event manifested once. When I ran the test, 40 W light bulb flashed before the whole bunch of charge, which was collected to the grids,

discharge through the safety spark gap (schematic Testla, look my folder romisrom). I tried to duplicate the Radiant-Event but it didn't manifest again. I think the interrupter-rotating rod burned somehow because it's resistance raised near two meg-ohms!!! I also have to make the carbon resistor different because it is not very stable, resistance range between 50 - 500 ohms depending temperature. I've also added in the spark-gap a strong NIB magnet to cut arc more faster. I think this magnetically quenched spark is very important to produce ERE. Anyway, test must be done again to make sure that it was ERE that manifest neither some other discharge.....unfortunately my testing is very slow because I live in another place due to my work and my test equipment are another place. So, it may take awhile.

(Tad Johnson) Congratulations!, sounds like a successful test run. You should get constant power off the grid once the circuit is tuned and stabilized. 300 Ohms on the end of the CSET seem to be perfect in my last test run.

Keep up the good work, no matter how slow it goes, it's worth it to humanity.

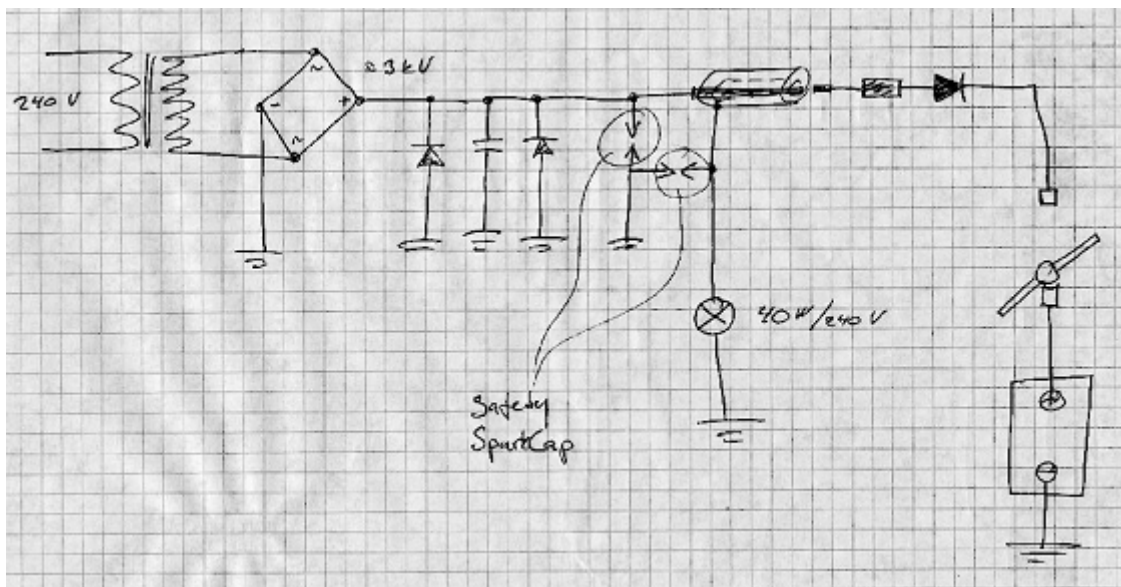

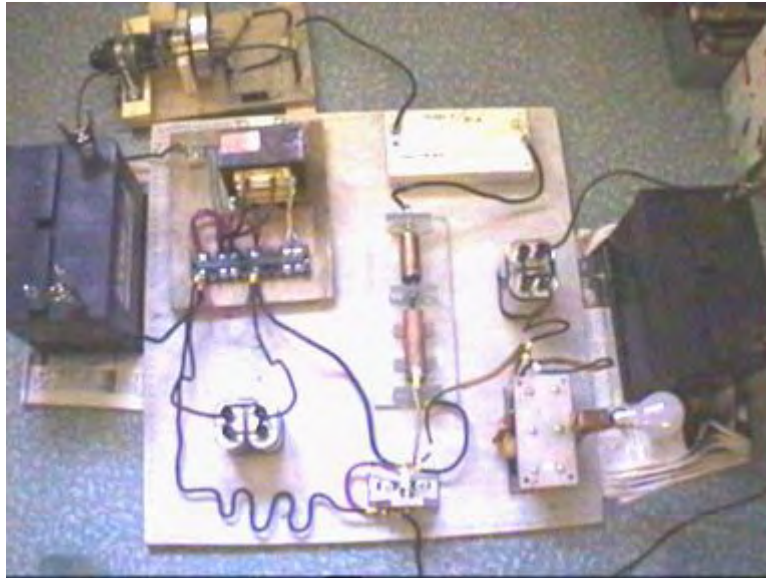

Subject: Progress **Date:** Sun Mar 30, 2003 5:21 pm

Hi folks,

I have not felt like doing much on the Gray device for a couple weeks since I have seen a relationship of mine fall apart after 8 years of being with this woman.

I am excited to see progress being made by Jani and Peer on their circuits and will hopefully find some "drive" to work on my system again soon.

Best wishes,

Tad

Note: This document is one in a series produced by Mr. McKay as part of his investigation of the work of Edwin Gray senior and he invites readers to contact him if they have any constructive comments or queries concerning the work of Mr. Gray. Mr McKay's e-mail address is mmckay@tycoint.com

Mark McKay's investigation of Edwin Gray's Technology: Part 6

Conversation between Mark Gray and Mark McKay on 5/19/07

Mark Gray is E.V. Gray's 6th child born in 1958 in southern California. For the past several years he has been a parts-room manager for a school district repair shop which maintains over 200 buses. He is a single parent who currently lives with his three young adult children. (Two daughters and one son).

Mark Gray was employed by his father, E.V. Gray, for the majority of the time between 1979 and early 1988. In this time period, he served in the capacity of a general assistant. He traveled and worked at seven different locations, including a two week long trip to Israel.

Under his father's direction he assisted in the building of the majority of the "Trigger Carts" (The converter systems under the pulse motors) that are displayed in the 1896 ZTEX promotion video. He also assisted in securing parts from custom vendors, video taped the technology, assisted with various demonstrations, drove the company truck, and wrote licensing agreements. These are just a few of the multitude of tasks he did during his tenure of service.

Mark parted on good terms from his father in early 1988 when funding ran out due to differences between E.V. Gray and certain investors, over the control and future of the technology. These differences were heightened when an alleged government contact, interested in a possible R&D program on the switching/triggering aspect of the technology, came into the picture late 1987 – early 1988.

While Mark had a tremendous exposure to his father's later technology (1979-1988), his detailed understanding of the underlying functioning principles is almost gone. He did what he was told to do and was compensated appropriately for his services, but never got deeply involved with the workings of the technology. For the past twenty years Mark has been completely divorced from his father's technology and has forgotten almost everything he knew about it. He regrets not having paid more attention and not having taken a real interest in the "nuts and bolts" of the processes.

Mark was most willing to share these anecdotal technical Tid-Bits that might have a bearing on rediscovering this lost technology.

The Mark I (Converter Switching Element Tube)

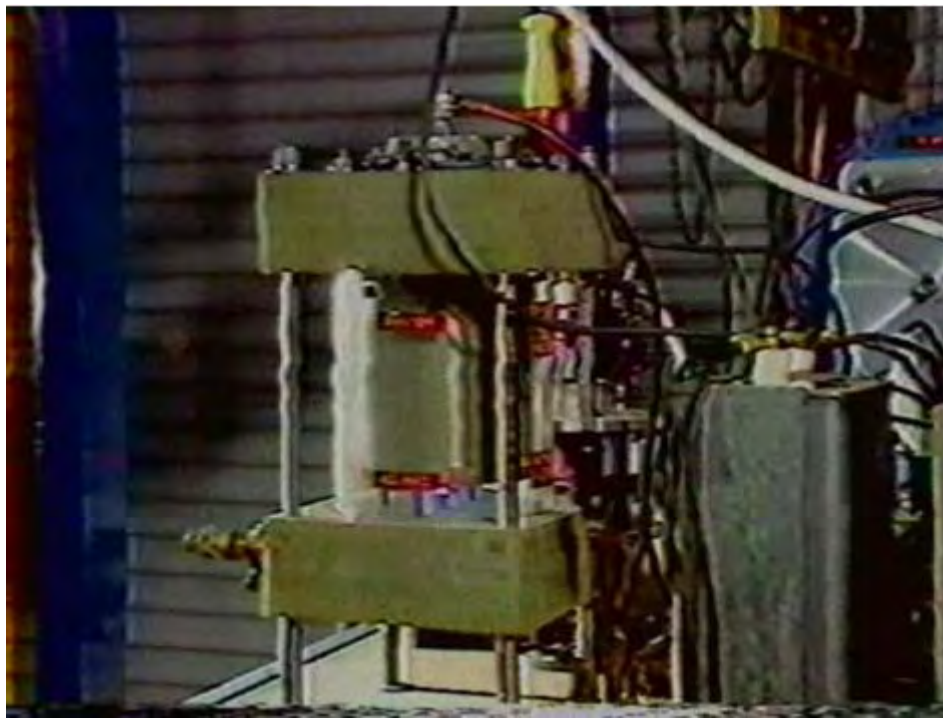

The cylindrical glass enclosure is a Colman gas lantern cover

- COMMENTARY: This really limits the magnitude of the internal pressure of what ever gas may have been present. The size of the end caps could support pressures up to 6000 psi. With such a thin glass envelop anything over 3 psi would be difficult. "He didn't want to pay the high price for a machined enclosure"
- all electrical connections were made from the top

COMMENTARY: I only see two electrical connections at the top of this device (the black center conductor and the white conductor with the large yellow single pin connector. Therefore the "Grid" is not connected to anything, unless it is connected to one of the electrodes.

- the gap was adjustable
- the internal gas was presumed to be Nitrogen from a welding supply house

COMMENTARY: Mr. E.V. Gray was very familiar with welding gasses. "He didn't get involved with anything that exotic" (Referring to S6F)

- Purpose of the Grids: "Possibly to cover up something he didn't want people to see?"

COMMENTARY: Like an additional series component, perhaps an HV RF coil?

- Was there an electrical connection to the "Grids"? "I don't recall"
- "the electrodes were made of Tungsten or Titanium. Which ever material Russia is famous for." [Titanium]



Ignitrons installed on the "Red Motor Cart"

The Mark II "Silver Cylinder" (Ignitron)

- This was an off the shelf commercial device that was a metal cylinder about 2" in diameter and 6" long.
- The terminal insulators were glass
- It was a two terminal device only, with wires connected to the top and the bottom.
- The round flanges were custom made end pieces to secure additional finned aluminum heat sinks that were attached around the periphery.
- The band in the center was a radiator clamp to hold it all together. Sometimes two clamps were used.
- These units did occasionally wear out or fail. New units were stocked on the shelf

- These devices contained Mercury and therefore retired units were treated with respect in storage.
- When these units arced inside you could see a blue flash through the terminal glass.

COMMENTARY: It appears these devices are Class A Ignitrons. They are the right size, right form factor and contain Mercury. However an Ignitron is a three, or more, terminal device. It operates much like a very high current thyratron. If there were no control connections for the igniter, then one use might have been a fixed-distance spark gap and just overvoltaged until it fired. One advantage of this approach would be a clean Mercury surface after each pulse. The pulse rate observed in the 1986 video is on the order of 2 Hz.

It is unclear whether these ignitrons were a replacement for the CSET or components in addition to the CSET. So far, the best explanation supports the idea that the ignitrons replaced the function of the rotating spark gaps that were in the commutator section of E.V. Gray's early motor designs. The 1986 Promotion video will show that E.V. Gray used several of these devices for his motors (up to six per cart). E.V. Gray probably developed a new system where the complexity of the old front end rotary spark gap array was no longer needed, thus greatly reducing the fabrication costs per motor.

Magnet wire for the Popping coils:

- All the wire for the construction of the projectile coils was standard copper magnet wire
- One company was contracted to machine the aluminum or plastic coils forms (Normally Nylon). Another company was hired to wind the coils. "We attempted to wind a few of our own coils. But not many"

Wire used in special places:

"That wire there was the expensive silicone filled wire that had to be used at that connection" pointing to the photo of the battery charger converter and the wires coming off the storage capacitor.

COMMENTARY: In the Cannady Interview it was noted how "Cold Electricity" would destroy the insulation on conductors. Apparently E.V. Gray did find a tentative solution to this problem by using special wire in the locations where it was required.

A Trip to the Capacitor Vendor

Mark Gray recounted an experience he had when he was instructed to return some defective capacitors to a custom supplier in Southern California.

The internal connection between the external capacitor terminal and the internal plates had opened up because the wire gauge was too small, thus causing it to fail. To explore this complaint first hand, the vendor opened up one defective unit with a can opener. Since the connection had been separated at this point there was still a substantial charge still left in the unit. There was an unexpected accidental discharge that caused a loud bang. Apparently the vendor quickly made repair modifications to all of the returned capacitors at no charge. Mark reports that the plates were gray with layers of a white material in between them. The entire unit was filled with a thick clear gel. Mark Gray claims he recalls values of 500 mF at 5 KV.

COMMENTARY: This type of construction implies a low inductance plate capacitor rather than the higher inductance rolled designs. The residual stored charge implies a low loss construction. I don't know about the dielectric, it could have been a standard poly material. Another authority claims E.V. Gray used Mica. I don't know what color mica is when installed in a large capacitor. "Cold electricity" is also known for its loud discharges.

The "Trigger Cart"



Mark Gray claims that the heart and soul of the E.V. Gray technology is the "Trigger Cart". This is the power supply that was the source of the anomalous energy for all of the projectile demonstrations. What is interesting about this system, is that it operates from 220 V AC, counter to all of E.V. Gray's previous motors and circuits.

COMMENTARY: Some researchers have proposed that the E.V. Gray technology required the use of wet cell lead-acid batteries for the generation of "Cold Electricity". Apparently this is not the case with the existence of this cart. However, the overall OU qualities of this technology may be impaired with the use of utility power. But at the time, E.V. Gray was seeking military customers who could benefit from the propulsion features of this equipment.

Trigger Cart Operation: "Slowly crank up the Auto-transformer until the tubes started to fire, then watch the volt meter. When it got to 5,000 volts I would quickly turn down the Auto-transformer and fire the projectile."

COMMENTARY: In the background sound of the demonstration video we hear about 20 pops before the projectile is ready for launch. It seems E.V. Gray was discharging one capacitor into another capacitor. Once this charging operation was complete he would discharge the collected anomalous energy through his opposing coils to launch a projectile. I don't know what he used for a discharge switch.

If Mark Gray was reading an analog voltage meter then we can be pretty sure that the anomalous "Cold electricity", when stored in a capacitor, can be observed as a positive classical voltage. This is very consistent with Tom Bearden's description of "Negative Mass Energy" - if the two phenomena are at all related. Earlier photos show E.V. Gray using an analog Triplett 630-A multimeter to measure the voltage of "Black Boxes" that are assumed to be storage capacitors in his early "Popping Coil" demonstrations (1973).

If the Pops we hear (20 or so per launch) are from the four Ignitrons on top of the cart, then it is reasonable to assume that the source DC supply voltage was in excess of 5 KV. If the Ignitrons were connected so that they would self-trigger by connecting the igniter to the anode, then there would be a sudden break-over pulse every time the voltage difference between the anode and cathode reached about 1500 V DC. This would imply that the source supply voltage was at least no lower than 8 KV.

Since there was a concerted effort to turn down the auto-transformer after reaching 5 KV, I would guess that E.V. Gray was charging his custom capacitors right to their design limits.

Auxiliary Capacitors:

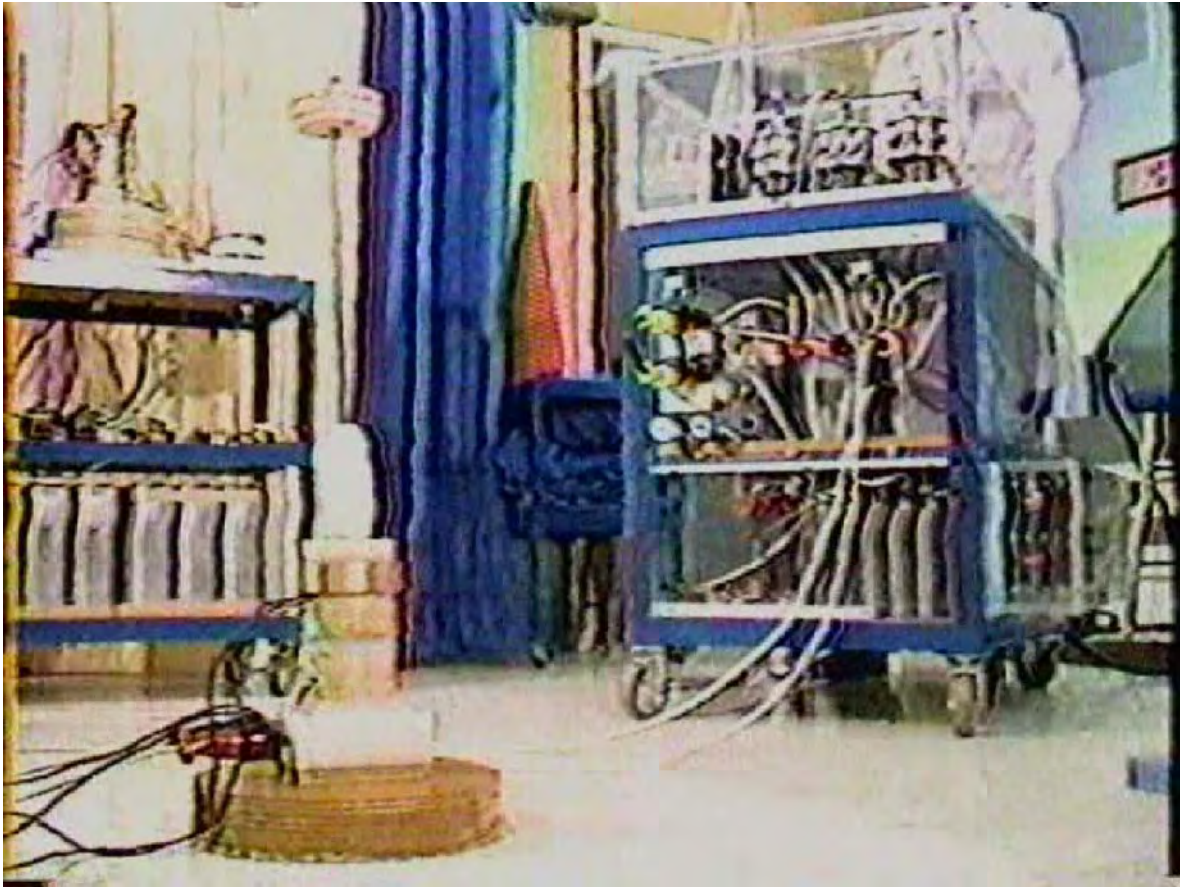

COMMENTARY: In this photo, note the “Projectile Cart” on the left. Six different types of projectile are launched from this demonstration platform. The bottom of this cart contains a pretty substantial capacitor bank array. You can see only 70% of the cart. This would imply that there are about 9 large capacitors in the first rank. If two rows are employed, then a total of 18 capacitors are needed. I suppose this sort of stored energy was needed to support the “Hover” demonstrations or the large 71 lb launch.

Mark Gray claims that this cart was in E.V. Gray’s possession at the time of his death. He plans to enquire among family members as to where this piece of equipment went.

COMMENTARY: It is my contention that if this cart was saved from the one way trip to the surplus re-seller, then who ever got it couldn’t make it operational. According to Mark Gray, his father spent his last days disassembling this equipment. This system would be high on the list of things to do first.

“Split the Positive?”

When asked if his father ever told him about the fundamental energy conversion process Mark Gray recalled one experience where his father told him “The energy starts from the positive terminal [of the storage capacitor/dipole] then part of it goes back to the supply battery and part of it goes to the load

COMMENTARY: This type of topology is shown in patent 4,595,975, but the actual technical meaning is anybody’s guess.

The “Wireless Projectile”

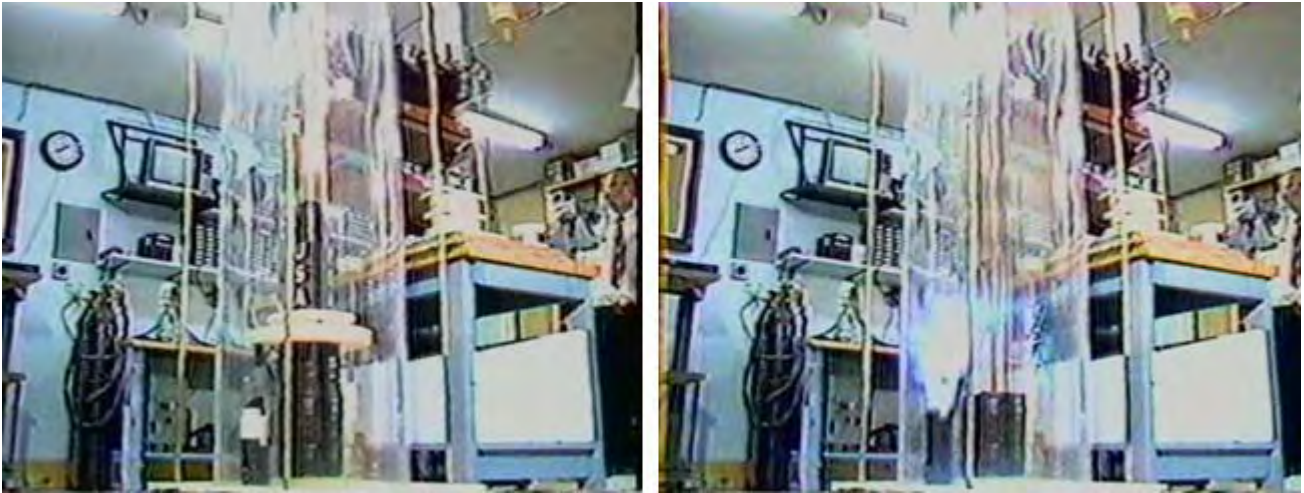

Mark Gray claims that some potential investors would ask “What good is this system if you have to have wires connected to projectile? That is not going to work”. So he developed this demonstration apparatus to show that the projectiles really didn’t need wires. Actually, they are needed for only a short distance, beyond which the magnitude of the repulsive forces drops off quickly. The above setup provided a sliding contact that is in the little black & white tower on the left of the larger black cylinder. This arrangement allows for about 6-8” of travel before electrical contact is broken. By that time, the travelling mass has received most of the shock impulse it is going to get. The black repulsing coils are composed of copper magnet wire that is about 2” deep. The outside is covered with black vinyl electricians tape. Mark also said that it was hard to reconnect the sliding contact because of rotation after a shot. Apparently it took a broom stick and a ladder to rest the demo.

COMMENTARY: The measurable voltage of the energy that propelled the small black cylinder on top with the (white plastic saucer on the bottom) was said to be 5KV. Now look at the length of the arc trail [about 12”] of the little contact tower (at the left) after lift-off. Consider what kind of voltage was being generated at this point.

The State of the Storage Batteries prior to a test or demonstration for a Motor Cart

“When a motor cart was prepared for a test (or demonstration) both sets of batteries were fully charged”

COMMENTARY: So much for the idea of having to start with a dead battery. This theory comes from the idea that the lead-sulfite was the medium that might have converted a pulse of classical electricity into “Cold Electricity”

Another Cold Electricity Demo using the “Start Motor”

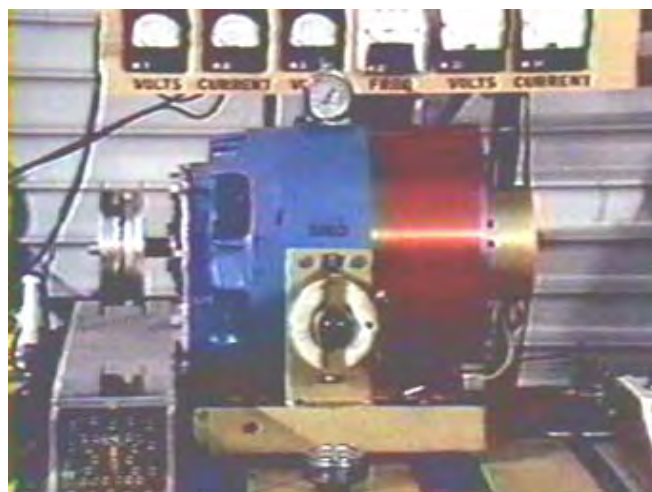

The white round dial instrument sitting on top of the “Start Motor” on the Multi-demonstration Cart is a thermometer. The other round dial instrument lying down on the table just below the round rheostat is a mechanical RPM indicator. [Biddle Meter]

The Importance of the Spark Gap

E.V. Gray told Mark Gary that the spark gap was very important.

COMMENTARY: A lot of other researchers think so too.



The Purple Motor



A Family Group Photo

Motor Names:

While the older E.V. Gray motors were numbered, the newer versions in the 80's were named according to a color. There was the Red Motor, The Blue Motor, The Purple Motor, The White Motor and the Black Motor. Each one was intended to demonstrate some particular aspect of this technology or head off any common questions that had continually arisen over the years.

Stump the Expert Time:

Once, a professional researcher, from MIT, was allowed to examine the equipment while development was taking place in Canyon Country, CA, (Possibly for some investor review). He had flight arrangements to leave the following Monday and had the whole weekend plus a day for his investigation. Apparently there were no restrictions placed on what he could look at. This man was alleged to be one of the co-inventors who developed the first anti-shark repellants. He examined and observed for at least one whole day and then made a comment to the effect, "If I can't figure this out, then all of my academic training is worthless". He worked all through the weekend and left the following Monday with no tentative classical explanation.

COMMENTARY: It would sure be nice to see if this individual would grant a phone interview. I'm sure he didn't talk a whole lot about his experience when he returned to Boston. I wonder if he would now?

Other Questions Asked through e-mail:

To your knowledge did your father (or his assistants) own or use any of these common electronics shop instruments?

*Oscilloscope
Radio Frequency (RF) Generator*

General Signal Generator
Pulse Generator
Transistor Tester
Q-Meter
Grid Dip Meter
Frequency Meter
Digital counter
Capacitor Tester
Battery Tester
Spectrum Analyzer
DC Power Supply

Of course any information about a general description, perhaps a Make and Model number (ha,ha), and an idea as to what the instrument was used for. When it was used and by whom.

Response 1) There were some meters involved, but I do not remember what meters might have been used or for they would have been used for.

2) The "kernel" of the technology appears to reside on the circuit trigger boards and the specific wiring to the off board components. From the photos we know that large power transistors were used. It is pretty obvious that other board components were used as well.

Do you happen to know what kinds of major components were on these boards? *We can assume that there were a number of supporting resistors and small capacitors*

Silicon controlled Rectifier (SCR)
Control Relays
Large Power Resistors
Transformers
Inductors or Chokes
Radio Frequency Coils
Vacuum Tubes
Diodes
Rectifiers
Power MOSFETS
Varistors
Potentiometers - Variable Resistors
Others
Model number of Power Transistors?

Of course a general description, approximate count, and any idea as to their function would be helpful.

Response 2) The most knowledgeable on the circuit boards may be Nelson 'Rocky' Schlaff (or Schloff) from the Los Angeles area. I do remember that the circuit boards were developed in Canyon Country and for awhile the services of an electronics consultant was acquired to help development some of this circuitry. I do not remember the name of the consultant.

3) *We know that you did a majority of the work on this equipment.*

Was there any specific part of these "Carts" that your father reserved for himself to work on exclusively?

Response 3) Actually, my father did not protect any specific area of any of the technology that I can remember. Many people had cast their eyes on and all over the technology that was built. Nelson Schlaff and myself did most the assembly of the technology. There were others from time to time that were involved with the technology built.

4) *Concerning the "Trigger Cart". You said that during its operation you would charge a certain capacitor to 5,000 volts before launching a projectile. You also said the voltage input was 220V AC. Here are some general questions about the over all construction of the cart.*

What Size Breaker was needed to power the "Trigger Cart" 30 Amp, 40 Amp, 50 Amp, higher?

Was a transformer use to raise the voltage from 220V AC to a higher voltage?

If 5,000 volts was the final measurable output voltage, then was there a higher voltage used somewhere else in the circuit that you know of?

Were Inductors or "Chokes" included on this Cart?

Did you ever have to make repairs on the "Trigger Cart", if so what was replaced and how often?

There are 4 "Ignitrons" on the Trigger Cart. Were all of these used at all times, or did different demonstrations use a different number of these devices?

Response 4) The only thing I remember about the voltage was charging the capacitors to 5,000v ?? for a one-time discharge (propulsion of a magnet), however, the hovering of magnets was achieved by a constant firing of the tubes.

5) Concerning the origins and nature of the transistor circuit boards used for the "converters".

Were these circuits made in house or contracted out? Did you make them? Did the design change over the years? If these boards failed who repaired them? Were replacements kept on hand?

Response 5) I do not recall much, if any was needed, maintenance on the circuit boards, nor do I recall having any made up as spares. I believe that all R & D and constructions of the technology happened in-house.

Mark McKay's investigation of Edwin Gray's Technology: Part 7

Edwin Vincent Gray (1925-1989)

Edwin Gray was born in Washington, DC in 1925. He was one of 14 children. At age eleven, he became interested in the emerging field of electronics, when he watched some of the first demonstrations of primitive radar being tested across the Potomac River. He left home at 15 and joined the Army, but was quickly discharged for being under age. At 18 he joined the Navy and served three years of combat duty in the Pacific. He narrowly escaped death when a bomb exploded on his ship's deck during an attack. He received an honorable medical discharge after spending some time in a navel hospital with head injuries.

After World War 2, he married his first wife, Geraldine, and started a family in Maryland. He worked as an auto-body and fender repair man. In 1956 he moved his family to Venice, California. A few months later he moved to Santa Monica where he began his first business named "Broadway Collision". A couple of years later, he opened a second shop in West Los Angeles. Both locations failed early in 1960 due to an economic downturn. He relocated to Prescott Arizona, and then to Littleton, Colorado in 1961. From 1962 until 1964, he worked in Las Vegas, Nevada, always in the auto-body repair business.

By 1965, Gray relocated to southern California again, and established a partnership with George Watson. Watson was a master car painter with an established clientele of Hollywood celebrities. A new location was established in Van Nuys, California on Calvert Street called "The Body Shop". It was a one-stop, high-end custom auto-body & painting shop. This business prospered well for the next three years until a conflict of romantic interests ended his first marriage (with seven children) in early 1968. A divorce followed in 1969.

(In 1971, Gray married Renate Lenz, the daughter of Fritz Lenz. They had three children. This relationship lasted 7 years. Gray married three more times after that.)

Towards the end of 1969, Gray terminated his auto-body business, never to practice it again. He sold 2/3^{rds} of the Van Nuys building to his nephew and re-outfitted the remaining portion to build and promote his next business enterprise. Somehow, Ed Gray had made a sudden and dramatic shift from the auto-body business to an independent inventor with an extraordinary technology, with hardly any previous background in electronics.

Members of his family are still baffled by the quick transition. Some say their father was occasionally struck with flashes of profound inspiration. Other researchers say that Gray must have been working secretly on the motors for years, but family members dispute this. Gray himself told one of his partners that he received this information from a Russian immigrant named Dr. Popov, who had gotten it from Nikola Tesla. But again, family members claim no knowledge of these supposed events. While there are similarities between Gray's technology from 1970 and Tesla's "Method of Conversion" technology from 1893, there is no known lineage to trace the connection between these two processes. No one ever saw Gray studying the work of Tesla, or running any preliminary experiments. No one who is still alive, who was associated with these events, knows where the technology came from or how it developed.

In 1971, Gray formed a limited partnership named EVGRAY Enterprises, Ltd. By 1972, Gray had gathered enough investment and development expertise to build a 10 HP prototype motor. This unit was submitted to Crosby Research Laboratories for evaluation at Cal-Tech. Crosby Research Institute was owned by Bing Crosby and run by his brother, Larry Crosby. This motor demonstrated an output of 10 HP (7460 watts of mechanical energy) for the extremely low electrical input of 26.8 watts. This is an apparent energy gain of 278 times the input! This left the Cal-Tech scientists very uncomfortable. The report states the motor operated at "over 99% efficiency", but the rest of the data is a little confusing.

On the strength of this report, Bing Crosby came on board as a major investor. So did 'Boot' Mallory, of the Mallory Electric Company, who made the high voltage ignition coils used in Gray's circuits. By early 1973, EVGRAY Enterprises, Inc. had completed a 100 HP prototype motor called the EMA4-E2. Fifteen private investors were now involved. Ed Gray also received a "Certificate of Merit" from Ronald Reagan, then Governor of California, during this period.

By the summer of 1973, Gray was doing demonstrations of his technology and receiving some very positive press. Later that year, Gray teamed up with automobile designer Paul M. Lewis, to build the first fuel-less, electric car in America. But trouble was brewing when a disgruntled ex-employee made a series of unfounded complaints to the local authorities.

On July 22, 1974, the Los Angeles District Attorney's Office raided the office and shop of EVGRAY Enterprises, and confiscated all of their business records and working prototypes. For 8 months, the DA tried to get Gray's

stockholders to file charges against him, but none would. Since he only had 15 investors, many of the SEC regulations did not apply. By March 1976, Gray pleaded guilty to two minor SEC violations, was fined, and the case closed. After this investigation ended, the DA's office never returned any of his working prototypes.

In spite of these troubles, a number of good things were happening. His first U.S. Patent, on the motor design, issued in June of 1975, and by February 1976, Gray was nominated for "Inventor of the Year" by the Los Angeles Patent Attorney's Association, for "discovering and proving a new form of electric power". Despite this support, Gray kept a much lower profile after this time.

But there were also other set-backs. Paul Lewis pulled out of his deal with Gray in 1975 when Gray couldn't deliver a production motor for Lewis's Fascination car. Gray made a last ditch effort to secure the needed capital to get his motor into production by calling a press conference in 1976 and demonstrating his nearly complete, second generation 100 HP motor, the EMA-6. Unfortunately, this event didn't secure any additional funds for the company. Shortly thereafter, Bing Crosby died in 1977, followed by 'Boot' Mallory in 1978. This left Gray without his two strongest supporters.

In 1979 Gray reorganized himself into ZETEX, Inc. and EVGRAY Enterprises, Inc. ceased to exist. In the process of this corporate restructuring, all of his earlier stockholders lost all of their money. Gray then moved his development operations to Kalona, Iowa where new investors were supporting his research. This working relationship also failed when these new partners attempted a hostile take over. In a sudden midnight flight, in the middle of winter, Gray loaded up the technology with all his belongings and headed to San Diego, CA where stayed for 18 months.

In 1982, he relocated his operations to Canyon Country, California where he hired three assistants to help build several large demonstration carts. After a year of work, Gray got suspicious of the loyalty of his employees. He abruptly fired all of them when they reported for work one morning. He then moved to a second location in Canyon Country and continued with the construction until early 1984. Later that year, he moved his operation back to Las Vegas where he stayed till the spring of 1985. In the summer of that year, he moved to the almost abandoned town of Council, ID (population of 816), where his oldest son 'Eddie' had settled down.

In Council, Gray finished up the construction of five different motor prototypes and several other kinds of demonstration equipment. He then began to produce promotional videos and invited local TV stations to report on his work. Gray then sought out the services of a Wild Cat oil exploration lawyer and found Mr. Joe Gordon of Texas doing work in Montana. The two men formed a partnership under Mr. Gordon's established business Western States Oil. They also established a branch holding company in the Cayman Islands from which to sell stock in the new venture. Gray decided to move again, this time to Grand Prairie, Texas to improve his exposure to international investors.

On the strength of his videos alone, the Cayman Island operation was selling stock and raising capital quickly. Interested investors from Israel convinced Gray to spend two weeks in the Holy Land where a series of emotional group negotiations took place. An agreement was never reached. They conceded that the technology held a lot of promise, but it was not mature enough to be immediately employed on the battlefield. In addition Gray insisted on maintaining a controlling interest in what ever deal was cut. For whatever reasons, Gray came back with a much different attitude.

Meanwhile the agents who had been selling his stock in the Cayman Islands decided to give themselves large commissions, plus whatever other funds they had control of, and quickly move to Israel themselves. Apparently, they had also oversold the original stock issue by about three times.

Feeling swindled himself, Gray made a final, desperate attempt to get proper recognition for his achievements. He actually wrote letters to every member of Congress, Senators and Representatives, as well as to the President, Vice President, and every member of the Cabinet, offering the US Government his technology for Reagan's "Star Wars" program. Remarkably, in response to this letter writing campaign, Gray did not receive a single reply or even an acknowledgment!

In 1987, a person named Reznor Orr presented himself, claiming to be a "Government Contact". Mr. Orr first made straightforward offers to buy all of Gray's technology outright for a modest price. These initial proposals did not meet with Gray's approval, and he turned them all down. At about this time, Gray's income stream from the Cayman Islands stopped. Mr. Orr's next offers were much less friendly, and mixed with certain veiled threats. When Mr. Orr left town, "to let Mr. Gray think about it", Gray realized he had a serious problem. Out of money and under threat, he quickly held a massive liquidation sale, including personal belongings and family furniture he had had for years. Only the equipment and materials he could stuff into his Ford F-700 box van were spared. Gray drove to Portland, Oregon and hid out for six months.

Some time during 1987 - 1988, Gray became ill with a serious case of pneumonia and was hospitalized. He had been a heavy smoker all his life. He never fully recovered from this illness and required Oxygen from this point on. His reduced lung capacity made it much more difficult to continue his work.

From Portland he moved to Sparks, Nevada. Gray rented a combination living quarters and shop space in a light industrial area. He unloaded his truck and began to disassemble all of his demonstration carts. He was living with Dorothy McKellips at the time who claims that Gray still did experiments during the day but in the evening all the components were once again taken apart and mixed with other parts. Early, one morning in April of 1989, about 2:00 am, somebody suddenly started banging hard on one of the shop windows. Gray, in his compromised health condition, got out his gun and went down stairs to frighten off the intruder with a warning shot. The gun failed to fire. A few minutes later, Dorothy found Ed on the floor. It is presumed that the resulting stress caused Gray to suffer a fatal heart attack, although the exact cause of death was never determined. He was 64. The identity of the late night visitor is not known.

Gray's oldest son "Eddie" flew to Sparks, Nevada to identify his father's body. Later, he spent several months attempting to help a Kansas group recover the technology. But, Dorothy would not release any of Gray's equipment until she had received a large payment for herself. The Kansas group then got a court order to take possession of the technology. But the document was poorly worded and did not define exactly what "technology" really meant. The order did state that they had rights to all of the motors. Dorothy caught this fact and gave them just the bare motors, keeping all the power converters and other things in her possession. Dorothy then decided to have the last laugh before this looming legal battle could escalate much further. She had all the remaining equipment, videos, parts, drawings, and laboratory notes hauled away and dumped in the local land fill. Apparently none of the remaining systems that the Kansas group had on hand were complete enough to reconstruct. Meanwhile, the remaining millions of dollars of investor capital in the Cayman Islands bank account were tainted by the fraud of the over-sale of the stock. Ultimately, these funds were either confiscated by the local government in fines or simply swallowed by the bank, since no one could withdraw the funds without being arrested.

[This account of the life and times of Edwin V. Gray was compiled by Mark McKay, of Spokane, Washington, after numerous interviews with a number of Ed Gray's surviving children. This account is an attempt to piece together the most accurate retelling of Ed Gray's story ever made available to the public. Many of the details in this account are in direct contradiction of earlier accounts as reported in the newspaper clippings from the 1970's. These earlier accounts should now be considered to be in error.]

Mark McKay's investigation of Edwin Gray's Technology: Part 8

Evaluating Common FE Coupled Inductor Systems in Terms of Delay Line Parameters

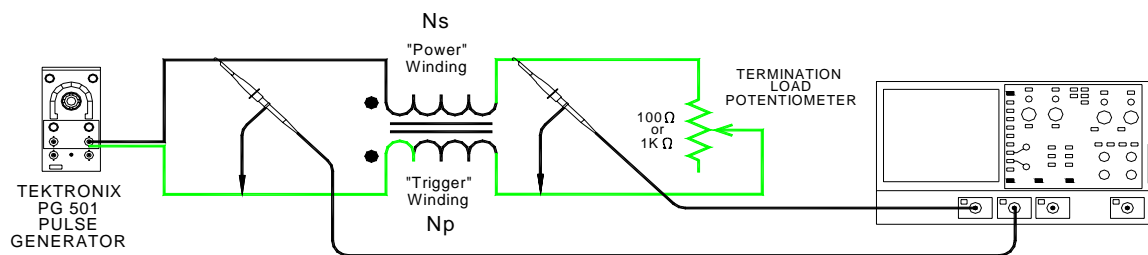

DETERMINING DELAY TIME T_d & CHARACTERISTIC IMPEDANCE Z_0

Coupled Inductors are a central component in a number of established Free Energy technologies. They have been used by Robert Prentice, Marvin Cole (E.V. Gray), Eric Dollard, John Bedini, Stan Meyer, and possibly Lester Hendershot. This is in addition to the vast array of coupled inductors that Dr. Tesla employed in his decades of research. Generally, modern independent researchers approach these devices from the standpoint of classical transformer theory and tend to view their operation in this way. I propose that, in many cases, these devices were intended to be used as Transmission Lines or Delay lines to take advantage of the unique features available with this topology. This is especially important when the characteristics of a high energy sparks are being engineered to achieve fast rise and fall times ($<10\text{ nS}$).

Volumes of detailed technical books are devoted to this complex subject. Specific applications are numerous because so many power and information signals are carried by transmission lines of one sort or another. However, in the realm of Free Energy the function of a Delay line appears to be relatively straight forward. Its common purpose is to act as a special kind of DC charged capacitor that will quickly deliver a fixed amount of disruptive energy to a spark gap. In applications that don't involve a spark, like the John Bedini motor, it is used (among other purposes) for sharp transition pulse formation using the same principles of operation.

There are two measurable parameters of a Delay line which are the foundation of most engineering analysis that will involve these devices.

- 1) The effective voltage time delay from one end to the other, abbreviated as T_d measured in seconds
- 2) The characteristic impedance Z_0 measured in Ohms

Both of these values can be easily measured with standard electronics equipment. This paper will utilize a LeCroy 9361 dual channel 300 MHz Oscilloscope with two standard 10:1 10 Meg probes and a Tektronix PG 501 pulse generator. A Fluke 87 VOM will be used to determine the resistance of potentiometer settings.

A good place to start this subject is to observe how a commercial Delay line functions. In this example an old 465 Tektronix oscilloscope twin-lead vertical input Delay line is evaluated. To best see its operation, the PG 501 was set to the narrowest pulse it could produce (25 nS) and applied directly to the Delay line input. A 100 Ohm potentiometer was set to 50 Ohms and connected to the Delay line output. The second oscilloscope probe was connected in shunt with the termination potentiometer.

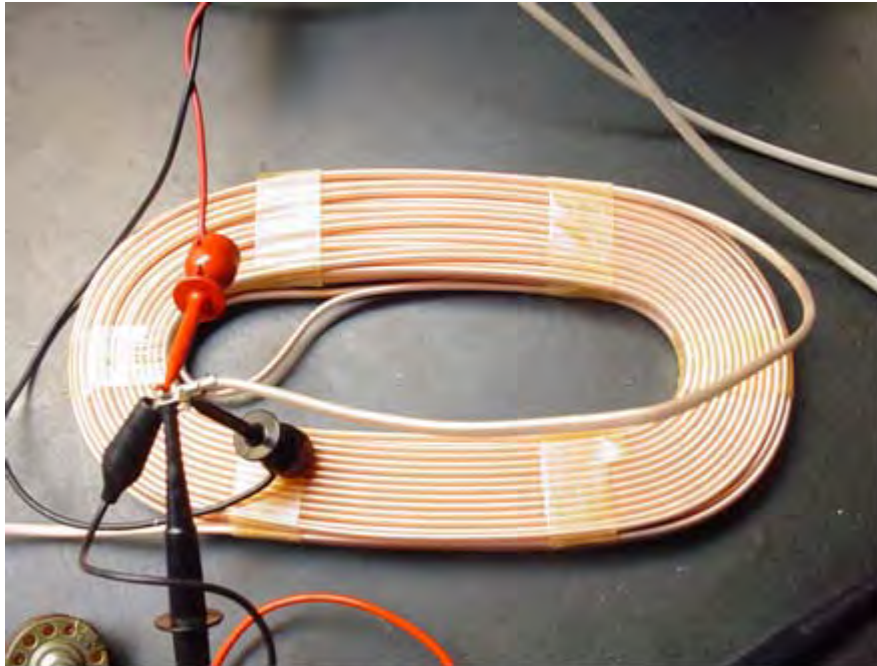

Vertical Delay line for Tektronix 465 Oscilloscope

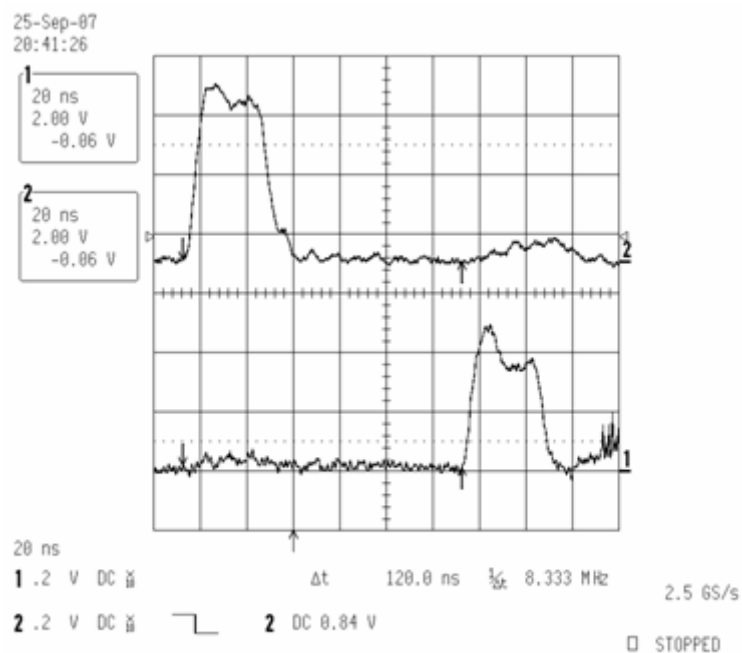

Resulting Trace using Two Probes

The two-channel trace from the oscilloscope (above) clearly shows the input pulse (Upper trace on Channel 2) and the output pulse (Lower trace Channel 1) delayed by 120 nS. While this straightforward approach will easily determine the delay time in a very low loss instrument Delay line, establishing delay times in homemade coupled inductors requires a different approach. If this present method were applied to most real-world coupled inductors, the output pulse will become so attenuated that it will be barely visible. The degradation of the input pulse increases as the coil under test becomes larger.

As it turns out, the energy in a 25 nS pulse is just too feeble to be observed in any homemade coupled inductor. This is because the parasitic capacitance filters out all of the high frequency components. Short pulses are just swallowed up in the unavoidable losses inherent in hand-wound inductors. However, another simple method, using the same equipment, can be employed to overcome these limitations. If the test input pulse is widened to some convenient length (to increase the applied energy) then the reflected pulse wave forms can be viewed. The actual delay time will be $\frac{1}{2}$ of the observed time between the leading edge of the applied pulse and the change in response that is caused by the termination resistance.

A good example would be to make measurements on a typical Bedini SG motor coil. The coil being measured is a bifilar design using #19 AWG magnet wire for the “Power Winding” and #24 AWG magnet wire for the “Trigger Winding” with 420 turns wound on a Radio Shack wire spool. The soft iron welding rods used for the core were removed.



Typical John Bedini SG Bifilar Motor Coil

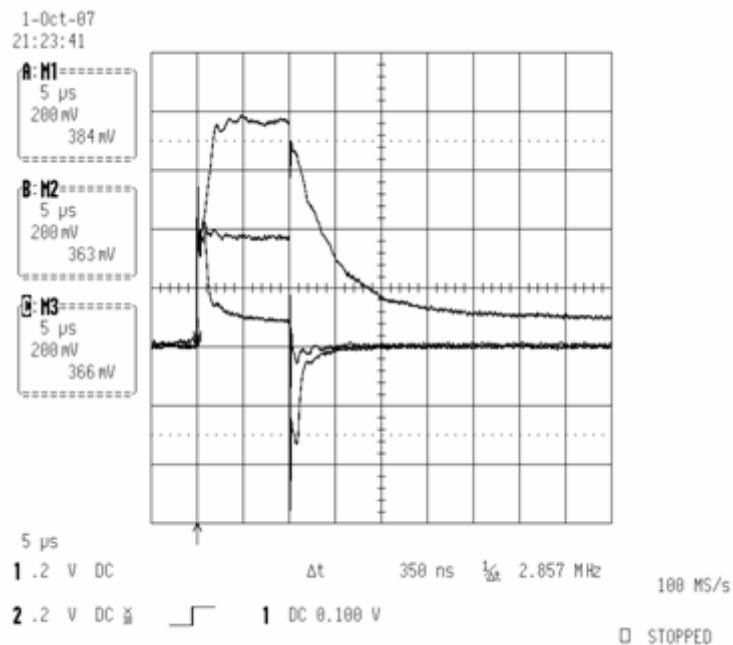

Dynamic Pulse Response

The first step is to establish the value of a load resistance R_L that will closely match the effective Z_o of the coupled inductor under test. This is done by applying a suitable pulse to the input of the Delay line (in this example we are using a 10 uS pulse) and then storing three traces:

- Upper Trace: Delay Line is open at the output end
- Middle Trace: Delay Line is terminated to a potentiometer adjusted to match Z_o . Adjusted for “maximum squareness”
- Lower Trace: Delay Line is shorted at its output end

What “maximum squareness” means is a matter of personal taste since there is always ringing and overshoots to have to deal with. However, when the potentiometer is close to the optimum value, small variations will make a big difference in the observed shape.

When the potentiometer is “dialed in”, it is then removed from the test bed and its resistance value measured with a VOM. In this example the result was 40.6 ohms.

If the iron welding rods are inserted into the core, no observable change is noticed in this series of measurements.

The next step is to expand our time base on the above pulse and store another three traces, following the same procedures as above.

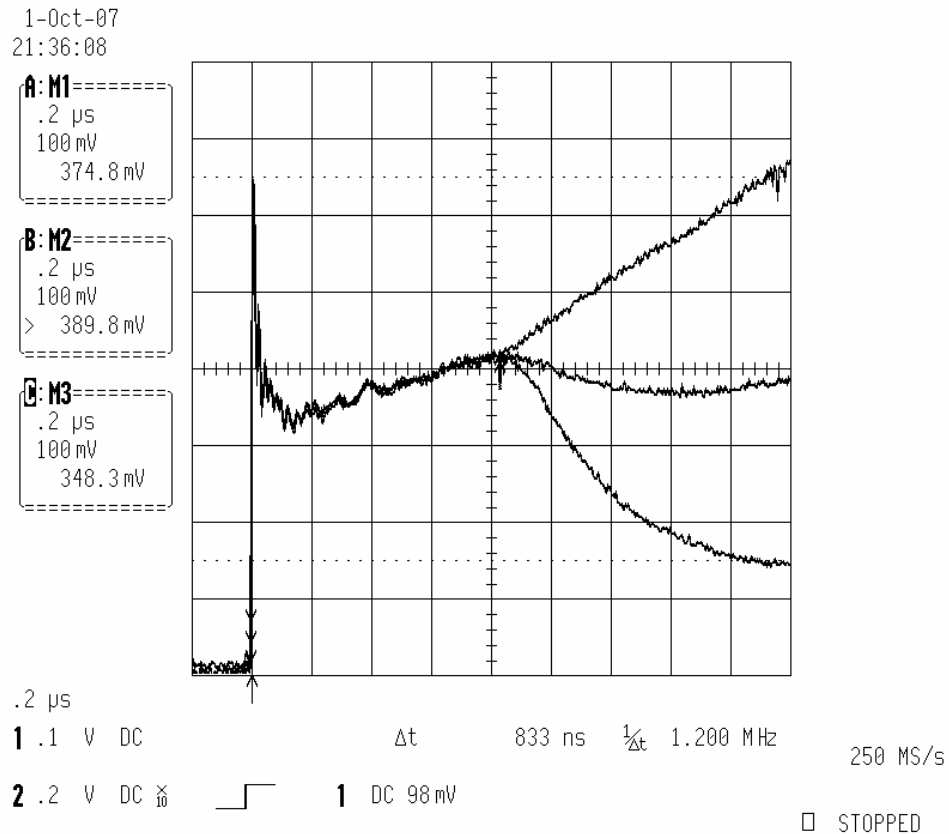

Leading edge of a pulse applied to a Bedini SG coupled inductor under three load conditions

Here, the time base has been expanded by a factor of 10X to view the leading edge of the applied pulse at 200 nS/div. The upper trace is the open condition. The middle trace is done with matched Z_o loading and the lower trace is the shorted condition. All three of these waveforms converge at one point. This point establishes how long it takes the applied pulse leading edge to travel to the end of the coupled inductor and return. The kind of load it finds attached at the end, then determines how it will respond from there on.

Measuring the time between the leading edge and this intersection, then dividing by 2 we arrive at the one way Delay Time for the coupled inductor under test. For this Bedini Coil we measure a T_d of 415.5 nS.

With this procedure we can go on to evaluate other kinds of FE coupled inductor systems:

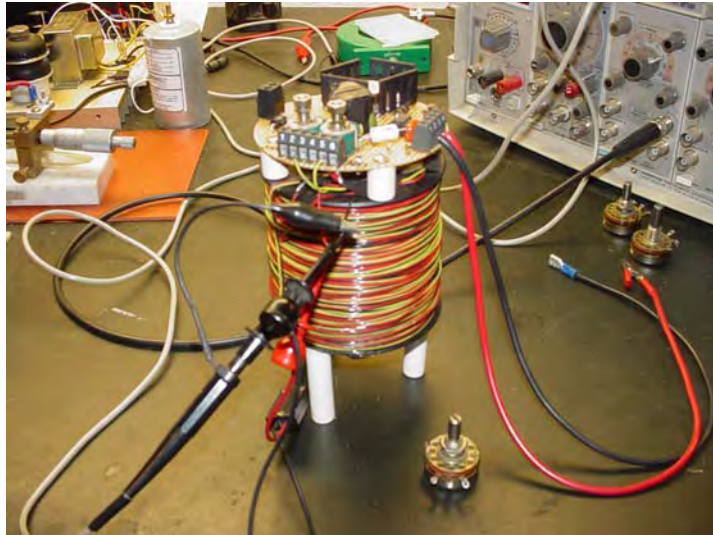

The Trifilar Lindemann Coil – 1000 Turns

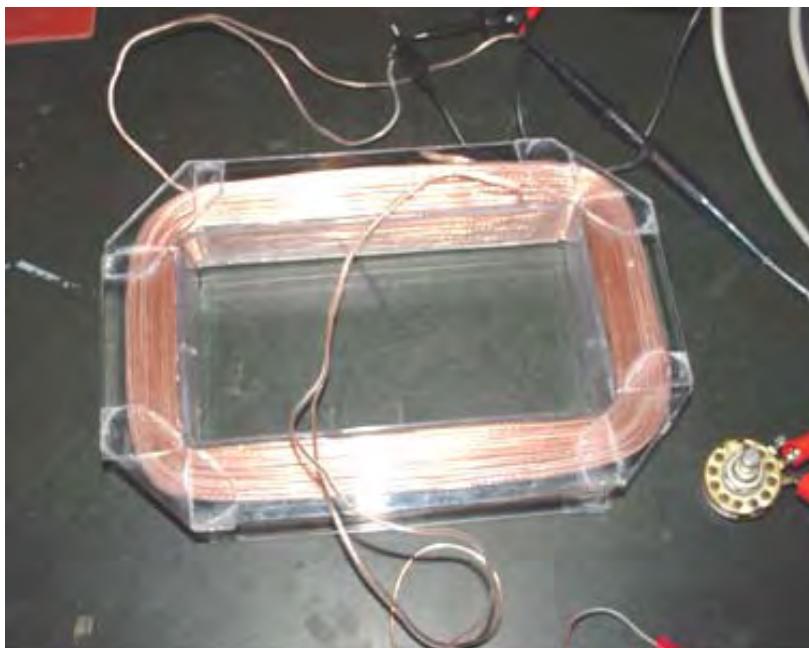
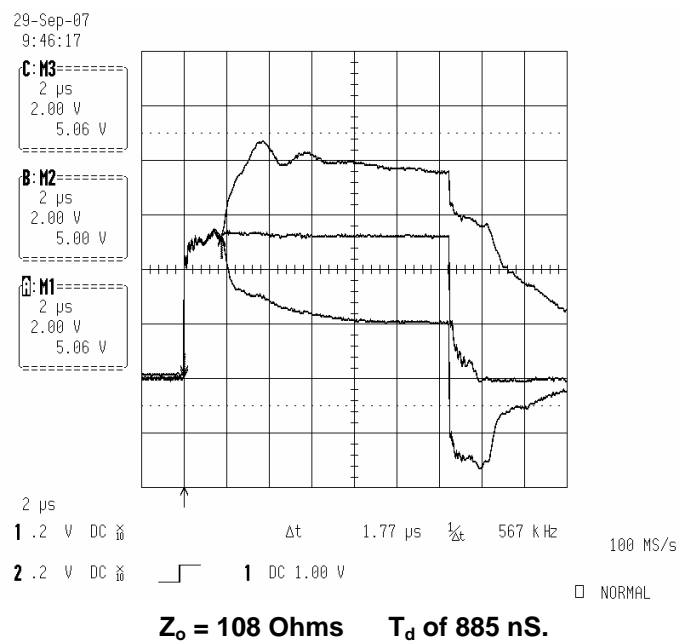

The Mike Motor Coil – 100' #22 Speaker Wire

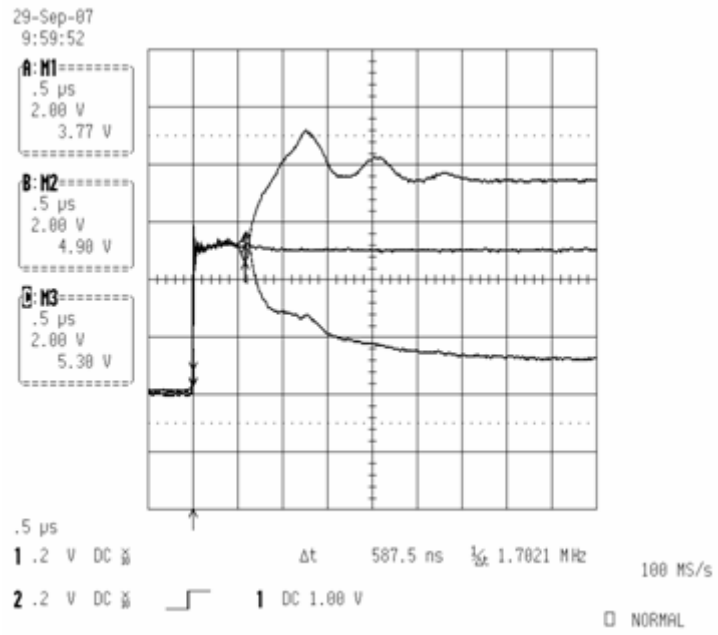

$Z_0 = 112 \text{ Ohms}$ T_d of 293 nS.

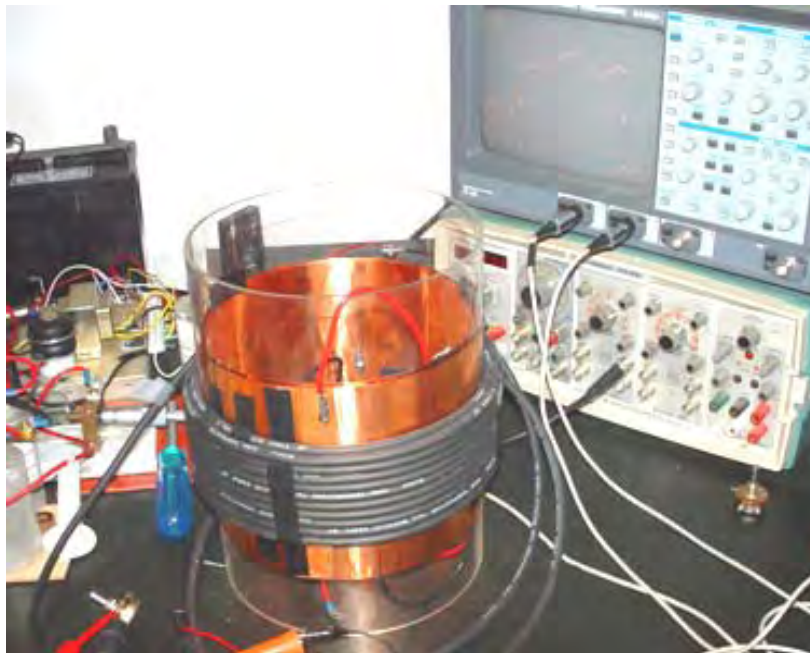

50 KV 8" Prototype Cole FFF

29-Sep-07
10:20:00

A: M1
50 ns
2.00 V
4.38 V

B: M2
50 ns
2.00 V
6.00 V

C: M3
50 ns
2.00 V
7.27 V

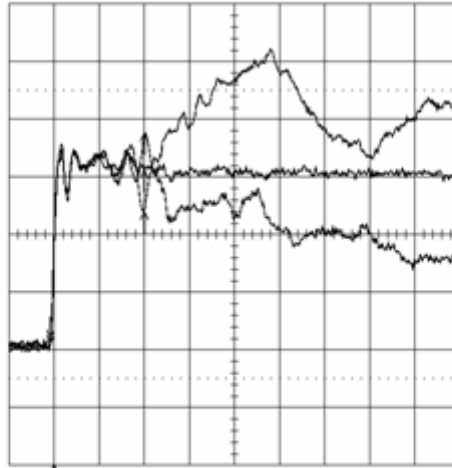

50 ns
1 .2 V DC \downarrow Δt 104.00 ns $\frac{1}{\Delta t}$ 9.6154 MHz 1 GS/s

2 .2 V DC \downarrow \square 1 DC 1.00 V STOPPED

$Z_o = 180 \text{ Ohms}$ T_d of 52 ns.

Mike Brady's "Perendev" Magnet Motor

Patent Application WO 2006/045333 A1

4th May 2006

Inventor Mike Brady

PERMANENT MAGNET MACHINE

ABSTRACT

The invention provides a magnetic repellent motor which comprises: a shaft (26) which can rotate around its longitudinal axis, a first set (16) of magnets (14) arranged around the shaft (26) in a rotor (10) for rotation with the shaft, and a second set (42) of magnets (40) arranged in a stator (32) surrounding the rotor. The second set of magnets interacts with the first set of magnets, and the magnets of both sets are at least partially screened so as to concentrate their magnetic field strength in the direction of the gap between the rotor (10) and the stator (32).

BACKGROUND

This invention relates to a magnetic repellent motor, or drive mechanism. Such a mechanism may be useful for driving an electrical generator, a vehicle, a ship, an aircraft, or the like.

Conventional power sources rely on fossil fuels or secondary power sources such as nuclear power, or electricity derived by whatever means, for its source of driving power. All of these sources of power suffer from disadvantages such as being the cause of pollution, requiring transportation or transmission over long distances to the point of use, and being costly to purchase. Thus, there is a need for a power source which is substantially pollution-free in operation, requiring substantially no external power, and which is simple to maintain.

SUMMARY

This invention provides a magnetic repellent motor which comprises: a shaft which can rotate about its longitudinal axis, a first set of magnets which are arranged around the shaft and which rotate with the shaft, and a second set of magnets arranged in a stator surrounding the rotor, where the second set of magnets reacts with the first set of magnets, both sets being partially screened magnetically in order to direct their magnetic field into a gap between the two sets of magnets. Thus, the interaction of at least some of the magnets of the first and second sets urge the shaft to rotate.

The interaction may be the net force of like magnetic poles repelling each other thereby urging the magnets away from each other, however, since only the rotor magnets can be moved by this urging force, the shaft is urged to rotate into a position where the repelling force is less.

The rotor may be substantially disc-shaped and the first set of magnets may be located in a peripheral region of the rotor which rotates with the shaft. The stator may be in the form of a pair of arms aligned with the rotor. These stator arms can be moved relative to each other and away from the rotor, in order to allow the gap between the rotor and the stator to be set selectively. The gap may be set manually, for example, by a hand wheel, or automatically, for example by a system of weights which move centrifugally and so form a rotational speed control which acts automatically, i.e. the smaller the gap, the greater the repulsion forces between the magnets of the rotor and stator.

Both the rotor and the stator may have more than one set of magnets. The magnets may be placed in sockets which extend towards the circumference of the rotor. These sockets may be substantially cylindrical and arranged in a plane which is perpendicular to the longitudinal axis of the rotor shaft. These sockets may also be arranged at an acute angle relative to the tangent to the circumference of the rotor disc where the mouth of the cylindrical socket is located. Similarly, the stator magnet sockets may be angled relative to the inner circumference of the stator. These angles may be between 18 degrees and 40 degrees, but preferably between 30 degrees and 35 degrees.

These sockets may have a socket lining consisting at least partially of a magnetic screening material. The socket lining may line the entire extent of the sockets so that only the opening to the exterior remains unlined. In another embodiment of the invention, the magnetic screen lining may cover a substantial percentage of the whole of the socket lining, e.g. 50% of the socket lining.

The magnets may be Nd-Fe-B of dimensions which fit snugly inside the linings of the sockets. These magnets may be cylindrical in shape and have a 37 mm diameter, a 75 mm length and a magnetic strength of 360,000 gauss. The socket lining, magnetic shield and magnet may all have a hole through them to receive a securing pin, preferably positioned so that it is parallel to the longitudinal axis of the shaft.

The number of sockets in the rotor and the corresponding stator may differ so that there is not a one-to-one relationship between the sockets in the rotor and the sockets in the corresponding stator. Similarly, the number of magnets in any additional rotor/stator sets may differ from the first rotor/stator sets in order that the two sets are out of register at any given time. Some sockets may be left empty in either the rotor or the corresponding stator, or both. The motor may have one or more rotor/stator pairs of this type arranged in a stack. It is preferable for the magnets of adjacent rotors to be out of register, i.e. staggered or offset relative to each other.

DESCRIPTION OF THE DRAWINGS

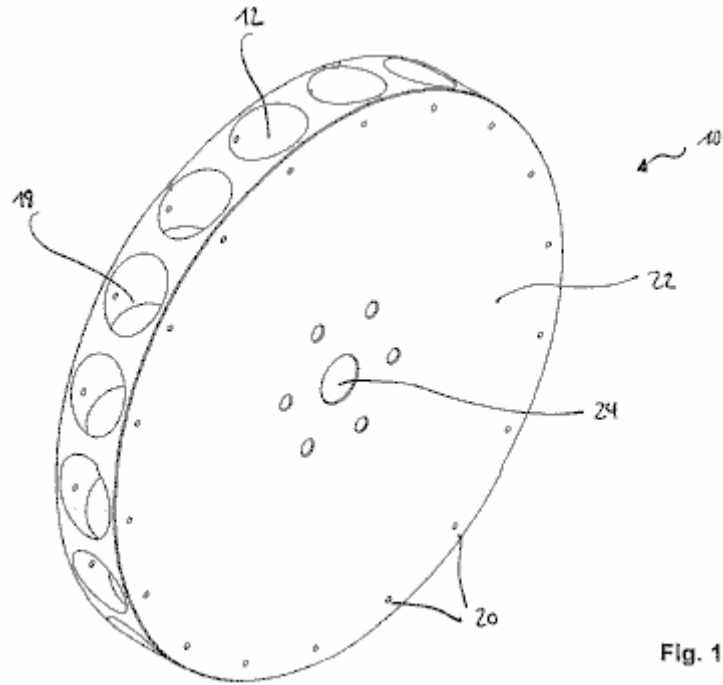

Fig. 1

Fig.1 is a perspective view which shows one rotor disc.

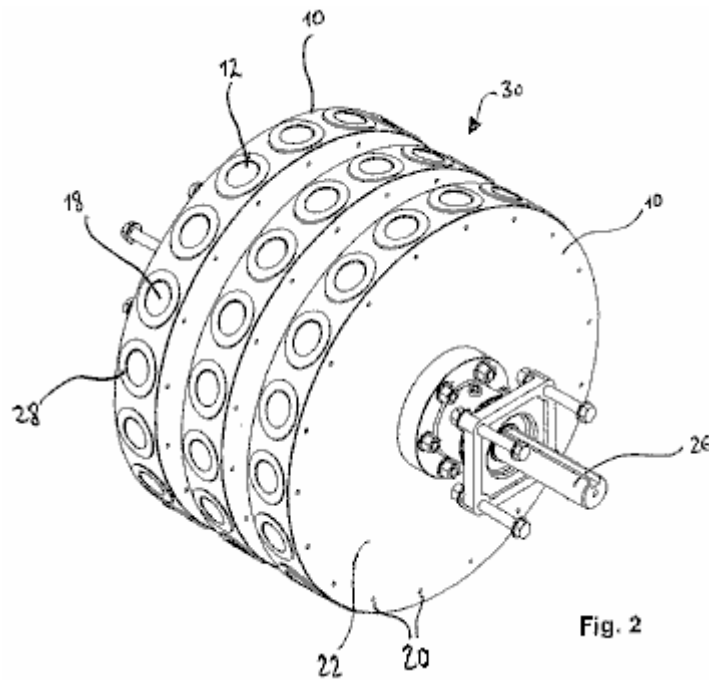

Fig. 2

Fig.2 is a perspective view showing a stack of the Fig.1 rotors in an assembled arrangement.

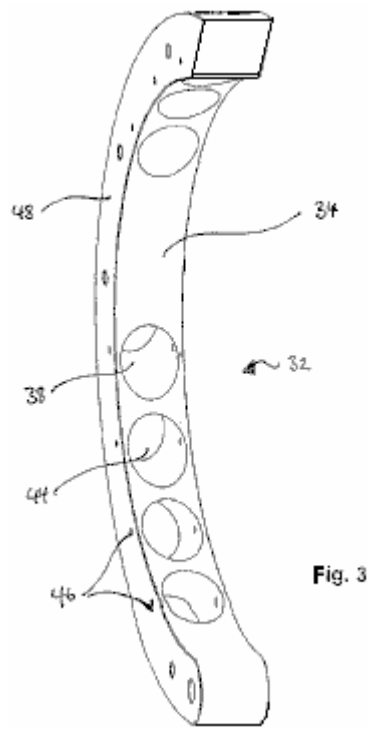

Fig. 3

Fig.3 is a perspective view showing a left arm of a stator.

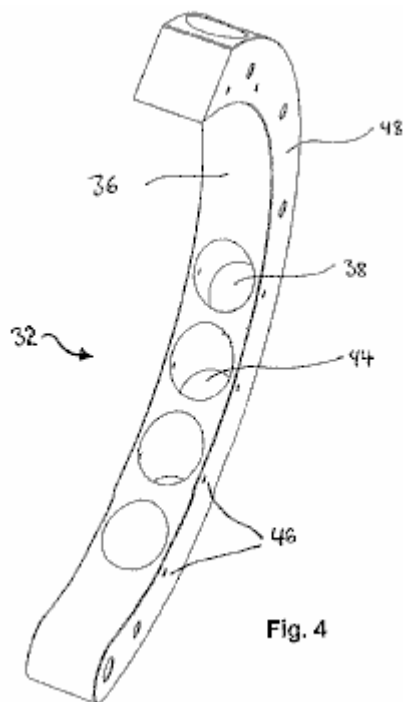

Fig. 4

Fig.4 is a perspective view showing a right arm of a stator

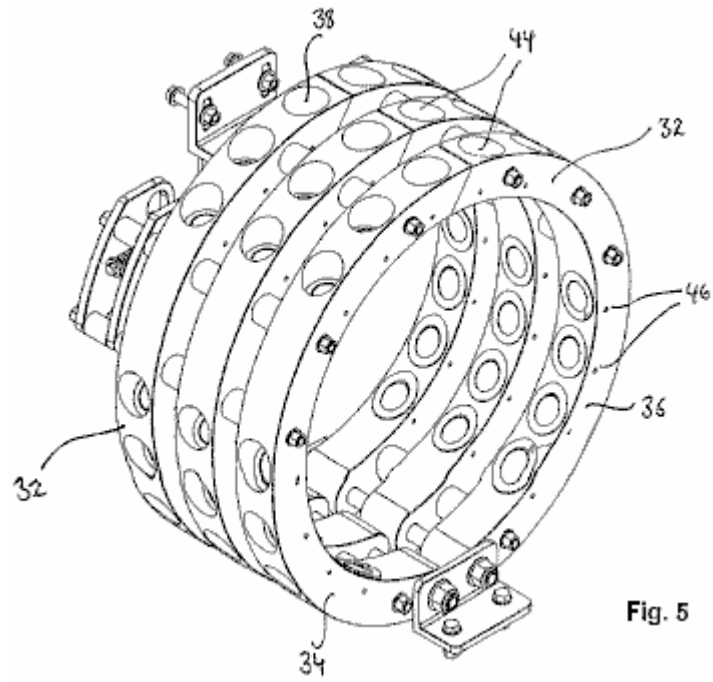

Fig. 5

Fig.5 is a perspective view showing a stack of the stators of Fig.3 and Fig.4 in an assembled arrangement.

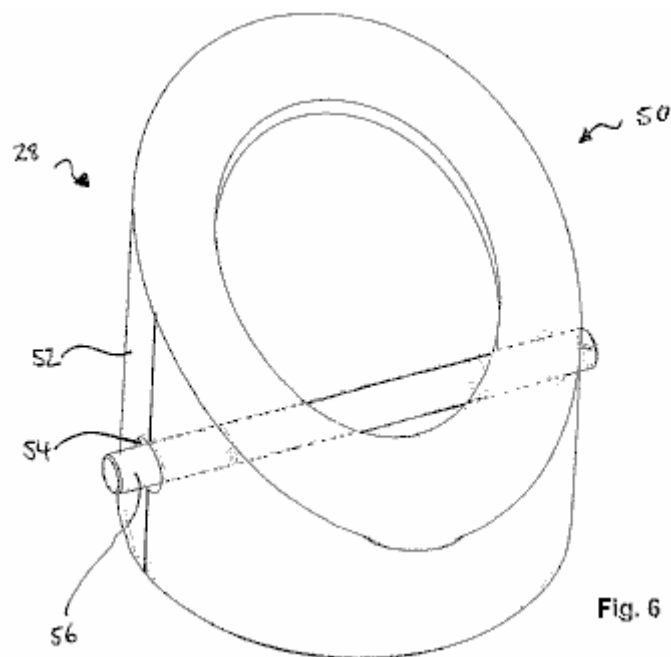

Fig. 6

Fig.6 is a perspective view showing a socket lining of a stator or a rotor.

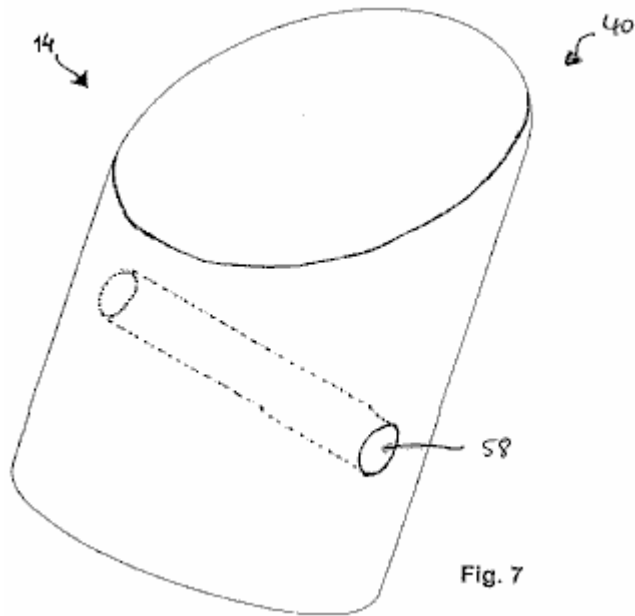

Fig. 7

Fig.7 is a perspective view showing one of the magnets.

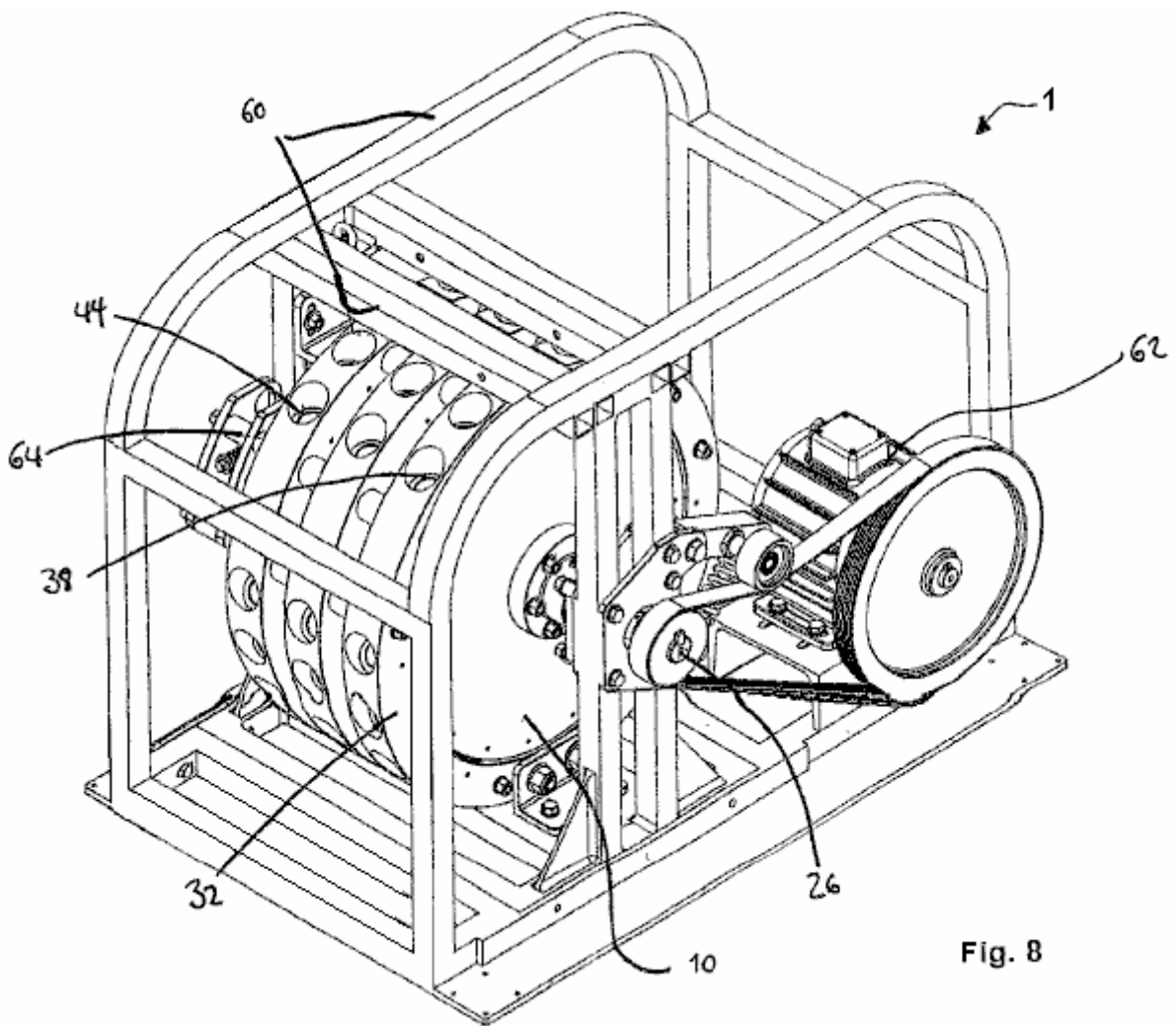

Fig. 8

Fig.8 is a perspective view showing one embodiment of the magnetic repellant motor coupled to an electrical generator.

DESCRIPTION OF PREFERRED EMBODIMENTS

Referring to **Fig.1**, a substantially disc-shaped rotor **10**, is made from a non-magnetic material. The rotor **10** has a plurality of magnet receiving zones **12**, provided in it for receiving magnets **28** (shown in later figures)

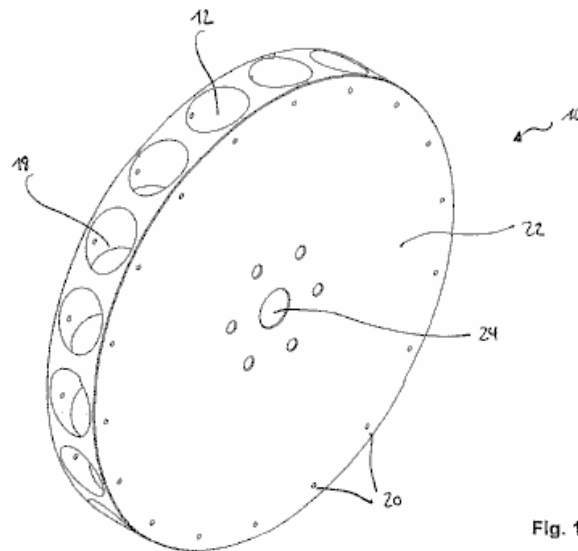

Fig. 1

of a first set **16** of magnets. The receiving zones **12** are in the form of circumferentially extending, spaced apart, and substantially cylindrical sockets **18** which are located in a plane which is perpendicular to the rotational axis **10** of the rotor and in a peripheral region of the disc.

In the region of the sockets **18**, the rotor **10** also has through holes **20** in its side surfaces **22**, extending parallel to the rotational axis of the rotor. The rotor **10**, also has a centre hole **24**, to receive shaft **28** which is shown in later figures. The sockets **18**, are preferably angled at an acute angle relative to the tangent to the circumference of the rotor disc **10**, at the mouth opening of the sockets **18**. Ideally, this angle is between 18 and 40 degrees, and preferably between 30 and 35 degrees. In one particularly preferred embodiment, the angle is 34 degrees.

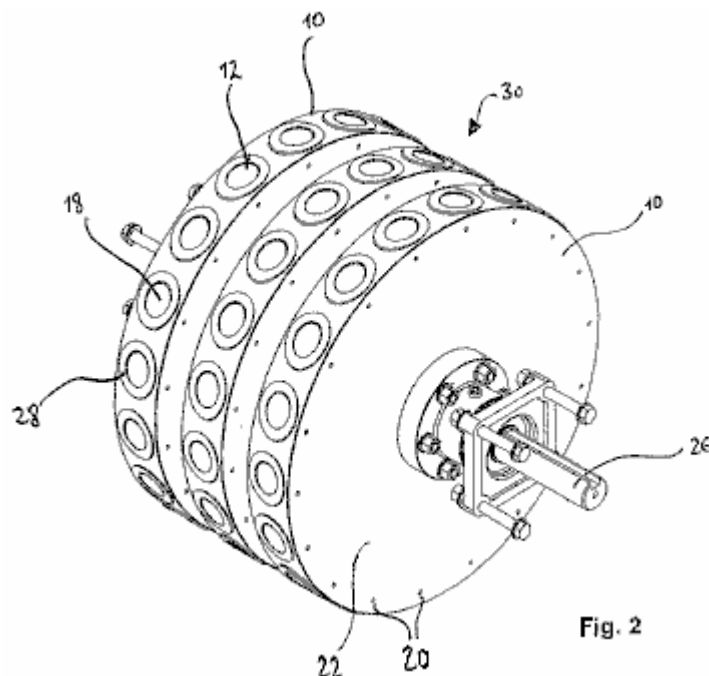
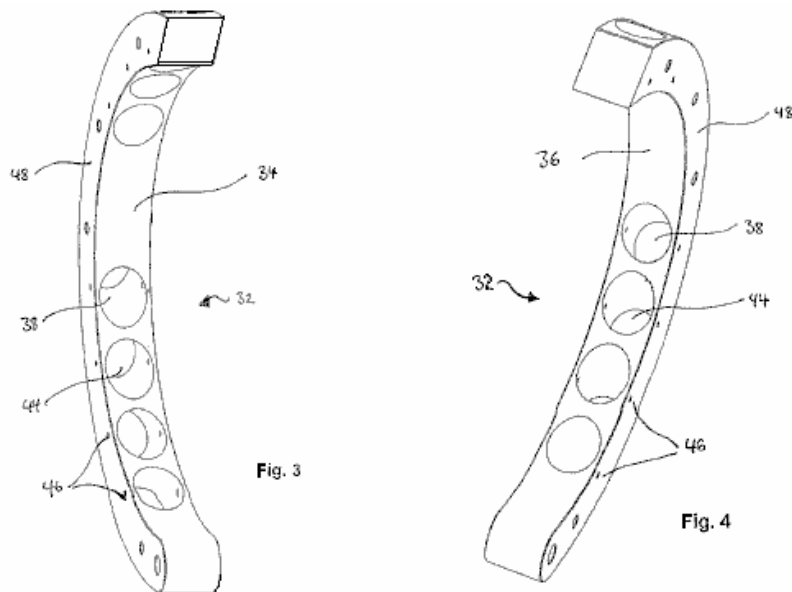

Fig. 2

As shown in **Fig.2**, the sockets **18**, receive (or incorporate) a socket lining **28** (shown in more detail in later figures) which is at least partially made of a magnetic screening material, whether metallic or non-metallic, for example, graphite. The socket lining **28**, covers the entire extent of the sockets **18**, so that only the opening to the exterior remains uncovered.

In the rotor assembly **30** of **Fig.2**, three rotor discs **10**, have been stacked in a row on the shaft **26**. The connection between the rotor discs **10** and shaft **26**, as well as between the rotor discs themselves, can be established via linking means which are widely known. In general, the motor may have any number of rotor discs **10**, and corresponding stators **32**, since the effect of using several rotor discs **10** in parallel, is cumulative. However, it may be useful for smooth operation of the motor **1**, to arrange the rotor discs **10** so that the magnets of adjacent rotor discs are staggered, or offset relative to each other.



Referring to **Fig.3** and **Fig.4**, a stator **32** is shown. This stator is made of a non-magnetic material. The left arm **34**, and the right arm **36**, combine to form the stator **32**. Each of the arms, **34** and **36**, has a substantially semi-circular shape and is sized so as to enclose the corresponding rotor disc **10** in the radial direction, while still leaving a gap between the stator **32** and the rotor disc **10**. The arms **34** and **36** of one stator **32**, can be moved relative to each other and their corresponding rotor disc **10**, so that the gap between the arms and the rotor disc can be set at different values.

The stator **32** has several magnet receiving zones **38**, ready to accept the magnets **40**, (which are shown in a later figure) of the magnet set **42**. These receiving zones are again in the form of circumferentially extending, substantially cylindrical sockets **44** which are positioned in a plane which is perpendicular to the longitudinal axis of shaft **26**. In the region of the sockets **44**, the stator **32** has through holes **46** arranged in it's side surfaces **48**, these holes extending parallel to the longitudinal axis of the shaft **26**.

These sockets **44** are again angled at an acute angle relative to a tangent to the inner circumference of the stator **32** at the mouth opening of the sockets **44**. This angle is preferably between 18 and 40 degrees and more preferably, between 30 and 35 degrees. The angle of the sockets **18** and **44**, and the relative positioning between them, has to be adjusted to allow for a good performance of the motor.

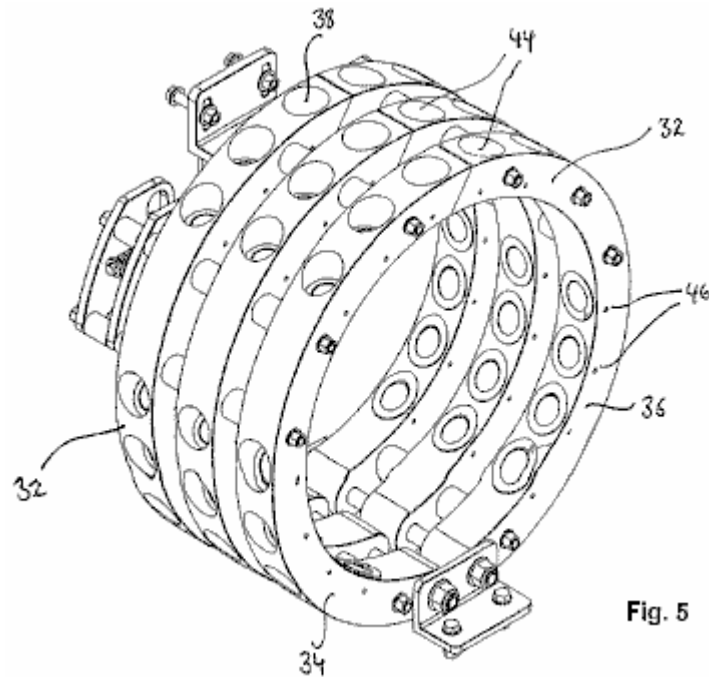

Fig. 5

Fig.5 shows a stator assembly consisting of three stators designed to fit the rotor assembly of **Fig.2**. As described with reference to the sockets **18** of **Fig.2**, the sockets **44** receive (or incorporate) a socket lining **50** (shown in more detail in later figures), which is at least partially made of a magnetic screening material. The socket lining **50**, covers the entire extent of the sockets **44** so that only the opening to the exterior remains uncovered.

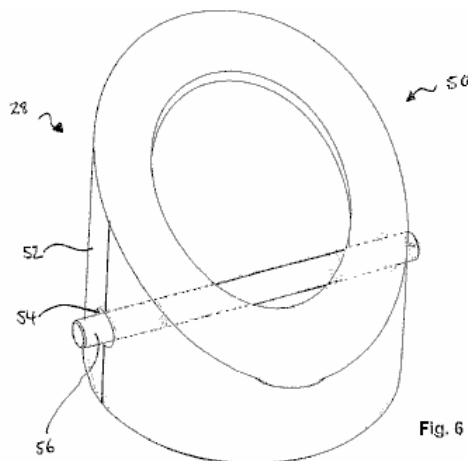

Fig. 6

Referring to **Fig.6**, a socket lining **28, 50** of the rotor disc **10**, or the stator **32**, is shown in more detail. The socket lining **28, 50** is formed to fit into the sockets **18, 44** and may be made completely of a material which has magnetic screening properties. In one preferred embodiment, the socket lining **28, 50** is made of diamagnetic graphite and is partially surrounded by an additional shield **52** of a material having strong magnetic screening properties, e.g. stainless steel. In the embodiment shown in **Fig.6**, the shield **52** surrounds about 50% of the socket lining surface.

Thus, by at least partially covering the sockets **18, 44** with a magnetic screening material, the magnetic field of the inserted magnets **14, 40** is, so to say, focussed axially with the socket **18, 44**, rather than dissipated about the magnets.

Further, holes **54** through the socket linings **28, 50** are provided and these correspond to the through-holes **20** and **46** in the rotor disc **10** and the stator **32**, respectively. Thus, a retaining pin **56** may be inserted after magnet **14, 40** has been put in socket **18, 44** to make a detachable fixing for magnet **14, 40** to the socket lining **28, 50** and the socket **18, 44** so as to prevent expulsion of the magnetic sources during operation.

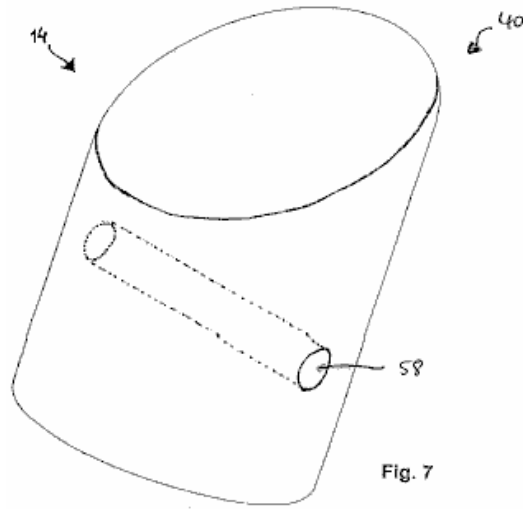

Fig. 7

Fig.7 shows a typical magnetic source **14,40** used in this motor design. The magnetic sources **18, 40** may be natural magnets, induced magnets or electromagnets. The magnetic source for example, is a Nd-fe-B magnet which has the necessary dimensions needed to fit neatly into socket **18, 44** and socket lining **28, 50**, respectively. In one preferred embodiment, the magnetic source **18, 44** is a substantially cylindrically shaped magnet with a diameter of 37 mm, a length of 75 mm and provides 360,000 gauss. However, the magnetic source **18, 44** may be shaped differently to cylindrical and may have different characteristics. In any case, the magnetic source **18, 44** must have a through-hole **58** to receive the retaining pin 56.

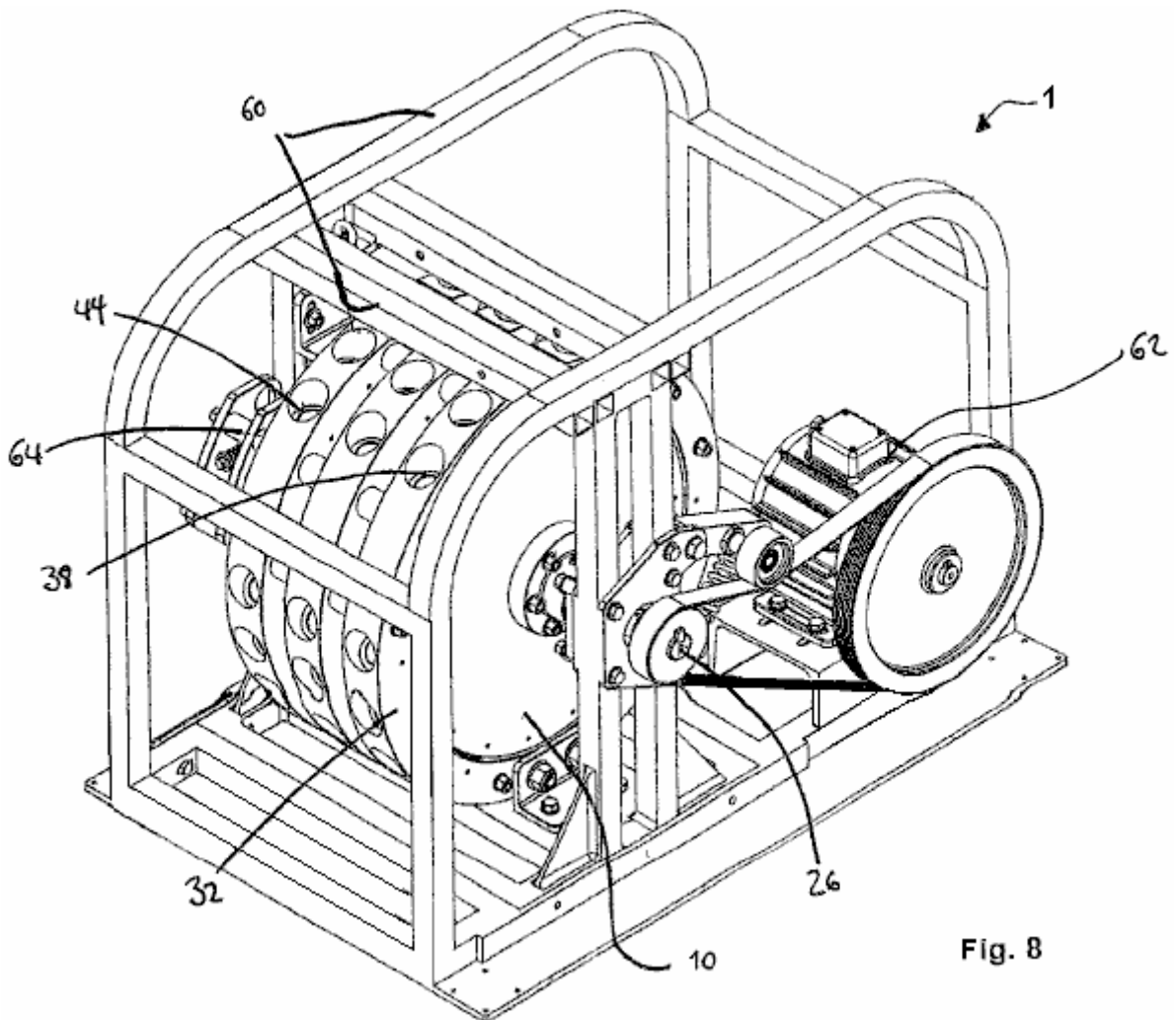

Fig. 8

The magnet motor shown in **Fig.8** is mounted on frame **60** and is coupled to an electrical generator **62**. In this specific embodiment, the motor has three rotor discs **10** of the type already described. These are mounted on a single rotating shaft **26** and are driven by three stators **32**, as already described, causing shaft **26** to rotate about its longitudinal axis. Shaft **26** may be connected to a gearbox in order to gain a mechanical advantage. The stator arms can be moved by a stepper motor **64**.

The number of sockets in the rotor discs **10** and their corresponding stators **32** may differ so that there is not a one-to-one relationship between the sockets **18** in the rotor disc **10** and sockets **44** in the corresponding stator **32**. Similarly, the number of magnetic sources in the stator **32** and the rotor disc **10** may differ so that a proportion of the magnetic sources **14, 40** are out of register at any given time. Some sockets may be empty, i.e. without a magnetic source, in either the rotor disc **10** or the stator **32**, or both.

The sockets **18** of the rotor discs **10** can be staggered, i.e. offset relative to the sockets of adjacent rotors, or they can line up in register. Thus, the magnet motor may be time-tuned by the relative positioning of the magnetic sources **14** of adjacent rotor discs **10**.

Thus, the interaction of at least some of the magnetic sources **14, 40** of the first and second set **16, 42** urges the shaft **26** to rotate. Once the shaft begins to rotate, the plurality of simultaneous interactions causes shaft **26** to continue rotating.

As mentioned before, the motor can have any number rotor discs **10** and corresponding stator sets **32**. Although the precise adjustment of the motor elements is important, one may imagine other embodiments covered by this invention.

The Magnet Motor of Donald A. Kelly

Patent US 4,179,633

18th December 1979

Inventor: Donald A. Kelly

MAGNETIC DISC DRIVE

ABSTRACT

This permanent magnet disc drive consists of two basic magnetic components, one large driven flat disc containing a uniform series of identical magnet segments, and a second magnetic driving means comprising multiple oscillating magnetic pairs of opposite identical magnet segments. The magnetic mechanism simulates the action of a clock escapement mechanism in that the oscillating magnet pairs uniformly oscillate between the disc magnet segments to induce continuous disc rotation. All of the multiple oscillating magnet pairs are oscillated by a motor, or motors, which provide an eccentric movement through a suitable gear reduction unit. The small DC motors are powered by multiple arrays of silicon solar photovoltaic cells at some convenient rooftop location.

US Patent References:

4,082,969	Magnetic torque converter	April, 1978	Kelly	310/103
4,100,441	Magnetic transmission	July, 1978	Landery	310/103

BACKGROUND OF THE INVENTION

At the present time the magnetic disc drive has reached the stage of development where the oscillating magnet pairs will rotate the magnetic segmented disc when the oscillations is done manually. The disc rotation is smooth and continuous when the manual oscillation is uniform and continuous, and the disc speed may be increased as the oscillation rate is increased.

Since the adequate functioning of the magnetic/mechanical-conversion concept has now been proven with a working prototype, a practical and economical self and/or external oscillation means for the oscillating magnetic pairs must now be developed. The magnetic disc drive was originally designed to be self-actuated by means of a multi-lobe cam and push rod arrangement, but this approach has not been proven successful to date.

A disadvantage for the self-actuated type of magnetic disc drive is that the disc is locked-in with a low, fixed speed output which is dependant on the natural magnetic field interaction between the involved interacting magnet segments.

A mid-diameter direct displacement multi-lobe cam was used for the first prototype, but this did not work because of the high rotational resistance imposed by the high cam lobe angles. A peripheral, direct displacement multi-lobe cam was also tried but this was not successful because of the moderate and sufficient cam lobe resistance to push rod displacement.

Other cam lobe configurations are being planned and developed to make sure that no possible trade-off to self-actuated mechanical oscillation is overlooked. Another possible approach to self-actuation for the magnetic disc drive is by the application of a twin level magnetic commutator which is directly connected to the disc drive shaft. The magnetic commutator segments alternately attract corresponding radial magnets on pull-rods which are pivoted on each of the oscillation plates of the magnetic pairs.

While auto-actuation of the magnetic disc units may be desirable for some self-contained power applications, the low, fixed speed output is not considered attractive and promising for a wide range of household power applications. Because of the inflexibility of speed output of the auto-actuated type of unit the, the development of a variable speed, externally oscillated type of disc unit is required to meet the growing demand for alternate and auxiliary power means for many applications.

The matching of a large magnetic disc drive and small solar powered DC electric motors is a nearly ideal arrangement since a single or series of small precision DC motors can be readily powered by modest arrays of silicon photovoltaic cells located at some convenient rooftop location. Small high-efficiency, ball bearing DC motors are available which, when connected to suitable gear reduction drives, can revolve a simple eccentric mechanism with sufficient power and variable speed, to cause oscillation of a series of four to six magnetic oscillating pairs of stator magnets.

This series of magnetic oscillating pairs will all be connected together with straight linkage to transmit the reciprocating motion from the driving oscillating shaft to the other oscillating shafts of the series. This is a more desirable multiple driving arrangement rather than separate small DC motors since synchronism is automatically assured, rather than more complex and less reliable electrical synchronization requirements. Because there is no locked-in synchronism for this type of external oscillation means, the multiple magnetic oscillation pairs must be of the minimum interference type, in that they must not become jammed into the disc magnet segments. Although the proper functioning of the magnetic disc unit requires that the oscillating magnet pairs must enter the disc's magnet segment interference circle, deflection means must be added to all of the oscillation plates to insure that the continuously revolving disc will readily by-pass all of the oscillating magnet pairs.

The large magnetic disc unit will consist of a basic non-magnetic circular disc, on which multiple high energy permanent magnet segments are equally spaced around the rim of the disc. The drive shaft of the disc rotates on precision ball-bearings and may be chosen to revolve in either a horizontal or a vertical plane. The disc is the driven component of the magnetic drive assembly, and it can be connected to the load or an electrical generator.

The multiple oscillating magnet pairs are the driving component of the disc drive unit and consist of flat, non-magnetic oscillation plates, on which identical high-energy permanent magnets are secured at each end of these oscillating plates. The magnet segments are placed with opposite poles exposed at the sides, relative to each other so that a north-south pole couple reacts on the disc's magnet segments. The driven disc's direction of rotation depends on the polarity of the disc's magnets in relation to the oscillating magnetic pairs.

The oscillating magnetic pairs will make a full back and forth oscillation between two adjacent local disc magnet segments so that an alternate "pull and push" effect is induced on the magnetic segmented disc. The basic synchronism between the disc's magnet segments and the multiple oscillating magnet pairs closely simulates the action of a watch or clock escapement mechanism in respect to the natural "cogging" action between the functioning components.

This general magnetic disc drive arrangement insures smooth and continuous rotation for the driven disc with an optimum of magnetic energy interchange between the oscillation stations and the magnetic disc because of near pole face to pole face exposure. It is now believed that this present type of magnetic disc drive is approaching a theoretical maximum of conversion performance possible, especially when compared with other types of magnetic/mechanical arrangements such as magnetic worm and worm discs, spur couples, mitre couples, and all types of inferior, linear magnetic devices.

The attractiveness of the basic magnetic disc and oscillating pairs is that a nearly ideal leverage factor is introduced in magnetic/mechanical conversion arrangements. Simply stated, considerably less energy is needed to oscillate the oscillating pairs than is produced from the near pole face to pole face magnetic interaction between the functioning magnetic components.

The alternating and uniform "pull and push" force imposed by the oscillating magnet pairs on the disc magnet segments produces no direct back or counter force reaction on the driving oscillating magnet segments which is the master key for a useful and practical magnetic/mechanical conversion drive. The back or counter-reacting force on the oscillating magnet pairs is taken directly by the fixed pivots of the oscillation plates, with a minimum of load penalty imposed on the drive of the oscillating magnet pairs.

All other types of rotary magnetic/mechanical conversion devices, with the possible exception of the worm and worm disc type, produce an undesirable back reaction force on the driving component and resulting ineffective performance. The magnetic worm and worm disc units have not proven to be sufficiently worthwhile for commercial applications because of the very high permanent magnetic energy necessary and due to the low speed output of these mechanisms.

When configuration comparisons are made of all types of possible magnetic/mechanical conversion devices it will be noted that the combination of a magnetic disc driven by multiple oscillating magnet pairs will stand out as a practical and useful permanent magnetic conversion arrangement. The incentive for the development of this magnetic disc drive was the direct outgrowth of overall disappointing performance of solar energy conversion efforts and the frustrations encountered with component costs, conversion efficiency and a lack of suitable energy storage means. While solar energy is being widely hailed for its future potential as a viable alternate energy source, relatively few engineers speak out about relatively poor overall cost/effectiveness due to days-on-end of overcast skies during the winter months when the energy is most needed, especially in northern latitudes.

Because of the less-than-adequate solar energy conversion outlook for the vast majority of American homeowners, other alternate, small scale, decentralised, energy sources must be explored and developed on a crash program basis. If this is not done within the next several decades we must accept the alternative of a greatly reduced standard of living because of the alarming rise in the rate of energy costs.

This magnetic disc drive represents a practical solution in applying permanent magnetism in the development and commercialism of a decentralised, silent, fuel-free, household-sized alternate power system. While the power output from an individual magnetic disc unit may be small, the power output is constant and does not generally depend on the intensity of an external energy source, as do present solar energy systems.

SUMMARY OF THE INVENTION

The magnetic disc drive unit is comprised of a large driving disc made of non-magnetic metal on which several permanent magnets are equally spaced around the rim. The disc drive shaft rotates on trunnion supported ball bearings and may revolve in nearly any conventional position, and may be constructed with any practical large diameter.

The identical oscillating magnet pairs are the driving component of the disc drive and consist of flat, non-magnetic plates on which, pairs of identical permanent magnets are secured at both sides of the oscillation plates. These magnet pairs have opposite pole faces facing each other. The disc's direction of rotation is determined by the polarity of all the disc's magnets relative to the polarity of the oscillating magnet pairs.

The oscillating pair of magnets make a full back and forth oscillation while each rotor disc magnet passes by. This produces a pull on the disc magnet as it approaches the oscillator magnet and then when the oscillator moves that magnet away, a push force is applied to the magnet on the rotating disc by the second magnet of the oscillating pair of magnets. The synchronisation of the disc and the oscillating magnet pairs must be maintained for continuous and smooth rotation of the disc. This movement is similar to the action of a clock escapement-mechanism.

The method of moving the oscillating pairs of magnets is one or more solar-powered DC motors. These motors drive push rods which are in contact with ball bearings mounted on the oscillation plates. Since the eccentrics must move at relatively slow speeds, suitable gear reduction units must be used between the motors and the rocker arms.

In order to maintain proper synchronisation of all of the oscillating components, straight links are used to connect all of the driven oscillation shafts to the driving oscillation shaft. Four or five oscillation stations can be driven from one driver oscillation shaft so that a disc drive with a large number of oscillation stations will require several D.C. motors to drive all of the other oscillation shafts.

It is important that the multiple, identical oscillation plates and their magnet pairs be slightly shorter in width than the space between two adjacent disc magnet segments, so that an optimum pull and push force is induced on the local disc magnet segments. One side of the oscillating magnet couple "pulls" on the disc's permanent magnet and then the other oscillator magnet "pushes" the disc's permanent magnet onwards as it has been moved into place by the oscillation.

All of the oscillating magnet pairs oscillate on stationary rods, or shafts, and all of the eccentrics and DC motor drives remain fixed on a base plate. The other ends of the oscillating rods or shafts must be supported by some form of bracket to keep the oscillation plates parallel to the disc magnet segments. Each eccentric which moves a ball bearing attached to arms on the oscillation plates must make one full 360 degree revolution within the angular displacement arc between two adjacent rotor disc magnet segments. Two small pivot brackets are attached to the extreme, non-magnetic ends of the oscillation plates to allow these plates to oscillate freely with a minimum of friction.

The basic rotational relationship between the magnetic oscillating pairs, and the magnetic segmented disc, will have a bearing on the gear reduction ratio required for the gear drive unit coupled to the small DC motors. Fairly rapid oscillation is necessary to maintain a reasonably acceptable disc speed which will be required for most power applications. The size of the eccentrics which oscillate the oscillating magnet pairs will be determined by the full oscillating arc needed and the mechanical advantage required by the oscillation plate in order to cause the optimum rotation of the magnetic disc drive unit.

Proper magnetic disc drive functioning requires the pulling magnets of the oscillating magnet pairs to enter the disc's interference circle within the mutual magnetic field zone between the two local interacting magnets on the disc's rim. Since the disc will revolve continuously, the withdrawing phase of the "pulling" magnets brings the "pushing" magnets of the couple into the disc's interference circle within the mutual magnetic field zone, for effective interaction with the adjacent disc magnet segment.

All of the magnet segments on the oscillation plates which form the magnetic couples must be in line with the corresponding disc magnet segments in order to maintain an optimum interaction between them.

Because there is no natural, lock-in synchronism for this type of magnetic disc drive, the multiple magnetic oscillating magnet pairs must be of the minimum interference type, which consists of adding plastic deflectors to the oscillation plates to prevent the pulling magnets of the couple from jamming into the disc magnet segments. Since the oscillating magnet pairs must never jam into the disc and stop its rotation, the plastic deflectors will allow the oscillation plates and magnet pairs to be deflected away from all of the disc magnet segments.

The permanent magnets selected for both components of the disc drive must be uniformly identical and have the highest possible energy product or magnetic induction plus coercivity. Both of these magnetic properties will play a significant role in determining the true value of the magnetic disc drive unit. At the present time the rare-earth/cobalt permanent magnets offer the highest possible magnetic properties for this application, but their cost is very high and currently not considered cost effective for the magnetic disc drive. Since costs will also play a major role in the competitive value of the disc drive, the magnets selected must show the highest possible cost/effectiveness ratio, along with long operating life.

Rectangular ceramic permanent magnets with large flat pole faces are preferred for the disc drive prototypes, and there is no theoretical limit to the size of both interacting components. A practical limit to the actual size of the components is imposed by weight and material cost restrictions plus available space, but nearly any practical number and size of uniformly identical magnets may be used to make up the magnetic disc drive.

It will be advantageous to build up each disc magnet station into clusters of up to about twelve to twenty four individual magnets which are arranged in lengths of four or five units and double or triple widths depending on the disc diameter. A large diameter disc unit is always desirable since the torque output for the disc unit depends on the tangential magnetic force produced by all of the oscillating magnet couple stations multiplied by the disc radius.

The large diameter disc speed will be relatively slow, in the 20 to 30 r.p.m. range, so that the disc output speed must be stepped up to a useful 750 to 1200 r.p.m. speed range, by a belt drive arrangement. The magnetic disc drive output is best adapted to run an electrical generator or alternator to produce electrical power for various household purposes.

An advantage to using silicon photovoltaic solar cells on an exposed rooftop location as a power source, is that they are capable of providing a partial E.M.F. under non-sunlight/overcast sky conditions. With full sunlight exposure the electrical energy produced will run the magnetic disc drive at its maximum possible speed, with reduced sunlight levels producing a corresponding proportionate reduction in the disc output speed.

A workable option exists for using a greater number of silicon photocells than would be normally necessary for full sunlight operation. The number of cells selected would be capable of running the magnetic disc drive at full speed under overcast sky conditions, with any excess full sunlight current bypassed to storage batteries. This option is a desirable arrangement since the disc will be assured of full electrical input power each day, with battery power available to make up the loss from any dark daytime sky conditions.

The principal object of the invention is to provide the highest torque output for the large driven disc from the lowest possible torque input for the multiple oscillating magnet pairs, as a useful power step-up means for electrical generating applications.

Another object of the invention is to provide a step-up power source which can be produced at competitive costs, requires no combustible fuel and is non-polluting while running silently and continuously.

It is a further object of the invention to provide a natural energy source which has an extremely long operating life, with a maximum of operating effectiveness, component resistance to degradation, with a minimum of parts replacement and maintenance.

The various features of the invention with its basic design geometry will be more apparent from the following description and drawings which illustrate the preferred embodiment. It should be understood that variations may be made in the specific components, without departing from the spirit and scope of the invention as described and illustrated.

Referring to the Drawings:

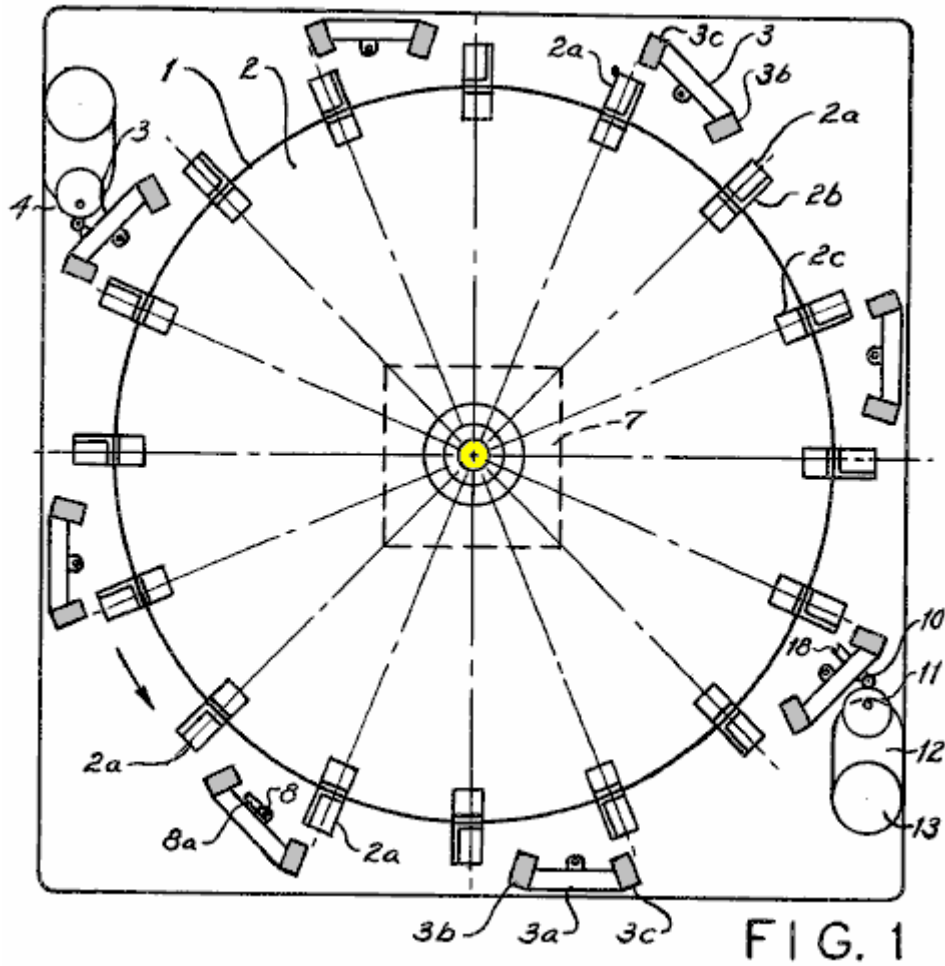

Fig.1 is a top, external view of the magnetic disc drive.

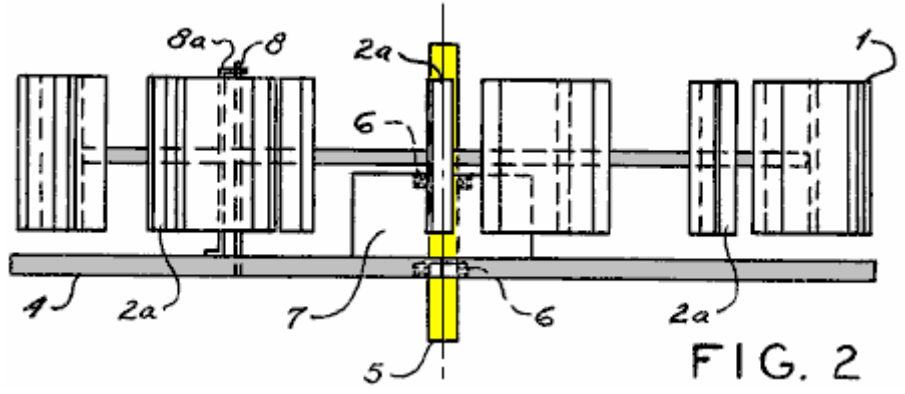

Fig.2 is an external side view of the magnetic disc drive.

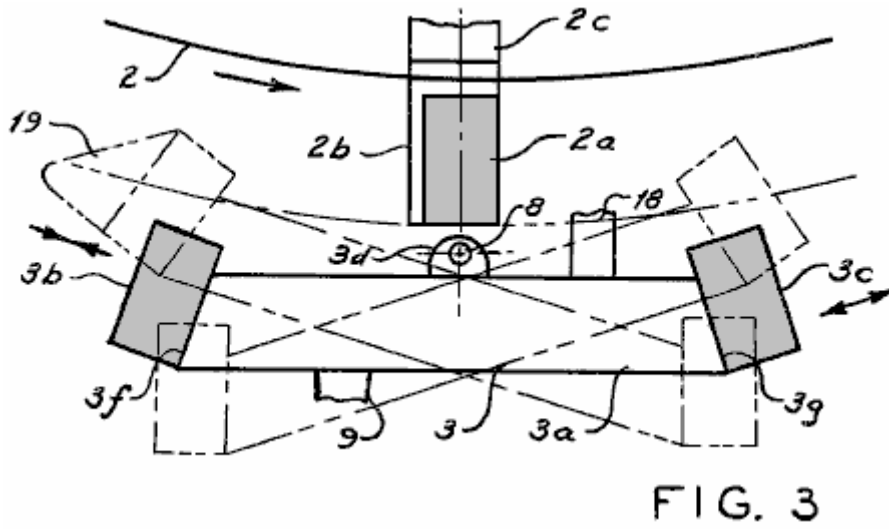

Fig.3 is an enlarged top view of one oscillating magnet couple.

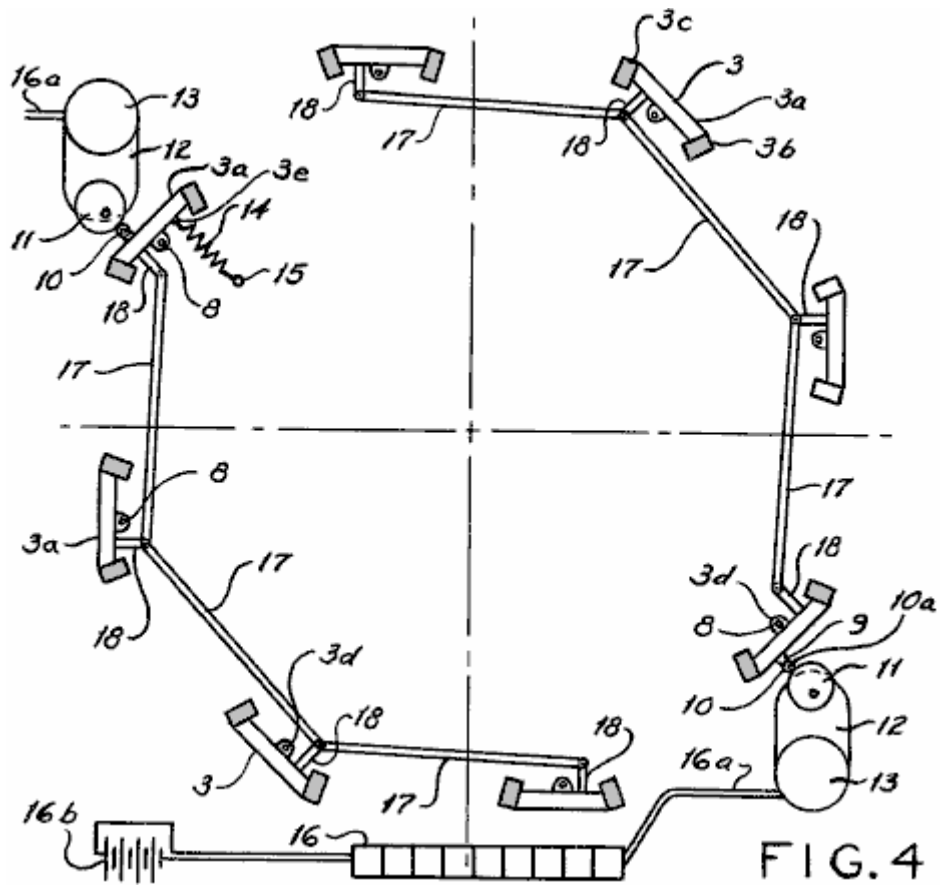

Fig.4 is a top, break-away view of several oscillating magnet pairs connected together with linkage.

DESCRIPTION OF THE PREFERRED EMBODIMENT

The invention 1, is comprised of two basic components: a large driven disc 2, and multiple oscillating magnet pairs 3, which are closely interrelated and mounted on a common base plate 4.

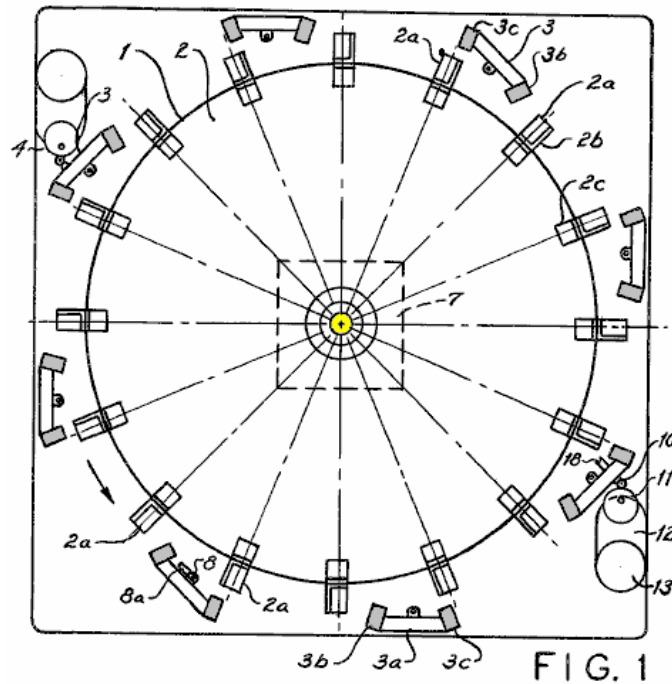

FIG. 1

Multiple, identical permanent magnets **2a**, are equally spaced around the periphery of the large driven disc **2**, by means of support angles **2b**, and angle brackets **2c**, which are secured to the disc **2**, with standard hardware.

A drive shaft **5**, is fastened to the disc **2**, by means of a hub **2d**, and supported by two ball bearings **6**. One of the ball bearings **6**, is fitted into a bore within the base plate **4**, while the other ball bearing **6**, is fitted into a box-base **7**, which is fastened to the base plate **4**, with standard hardware.

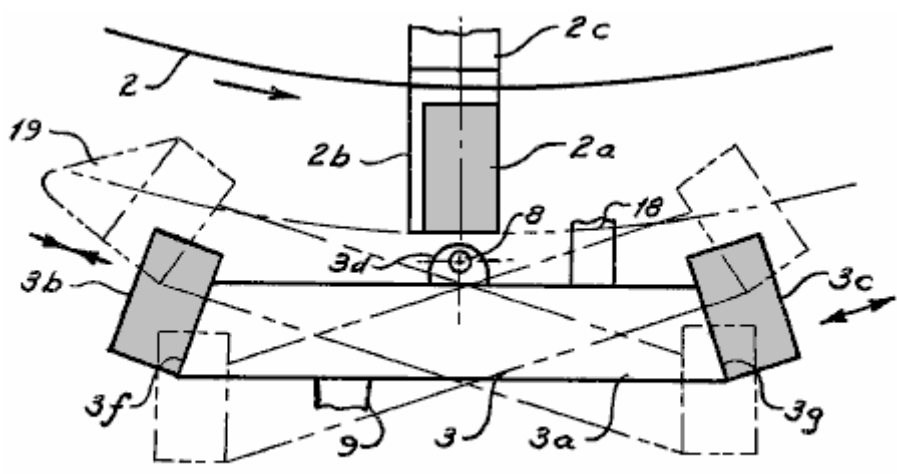
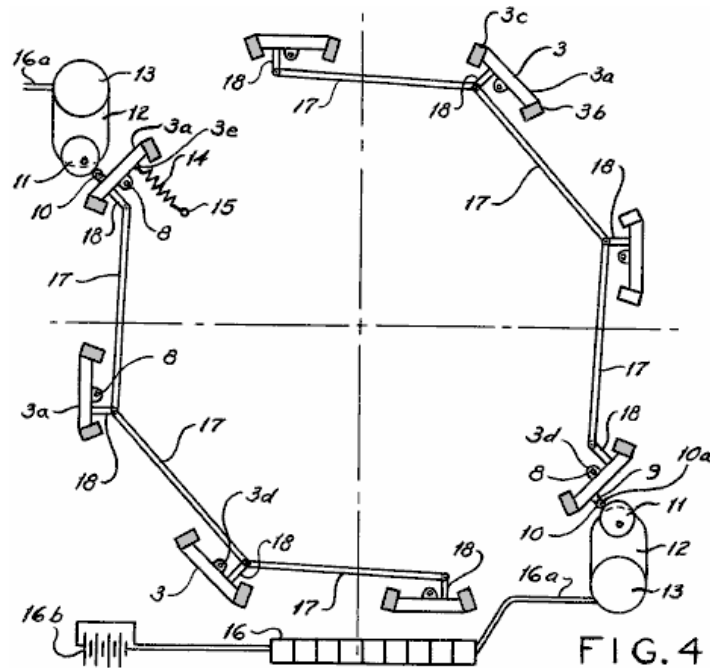

FIG. 3

The multiple oscillating magnet pairs **3**, are a flat, non-magnetic plate **3a**, with opposite pole magnet segments **3b** and **3c**, respectively, attached to the side of the flat oscillation plate **3a**. Two pivot brackets **3d**, are attached to the top and bottom of the flat plate **3a**, which pivot the oscillation plate **3a**, on the pivot rod **8**. One end of the pivot rod **8**, is fitted into the base plate **4**, and the opposite end is supported by an elongated Z-shaped bracket **8a**.



An arm **9**, is fastened to a flat face of the flat plate **3a**, which supports the pin **10a**, which carries the ball bearing **10**, as it rolls on the eccentric disc **11**. The off-centre disc **11**, is fastened to the slow speed shaft of the gear reduction unit **12**, which is driven by the small DC motor **13**. A return tension spring **14**, is connected to the oscillation plate **3a**, by eyelet **3e**. The opposite end of the return tension spring **14**, is retained by the post **15**, which is pressed into the base plate **4**. Motors **13**, are powered by multiple arrays of silicon photovoltaic solar cells **16**. Electrical leads **16a**, conduct solar converted electricity to the motors **13**, with any excess current stored in the batteries **16b**.

The motor driven oscillation stations become the master stations for this invention **1**, from which three to five slave oscillation stations are driven. The reciprocating motion is transmitted by straight links **17**, which are pinned to the link arms **18**, which in turn are secured to the flat plates **3a**.

All of the slave oscillation stations must be precisely adjusted to exactly the same angular position as the master driving oscillation station so that all stations are synchronised to allow proper functioning of the rotating disc **2**.

For very large discs **2**, with many disc magnets, several master oscillation stations, with a fixed number of slave oscillation stations will be required. All of the master oscillation driving-stations will have to be electrically synchronised to maintain overall synchronisation, with all of the eccentrics **11**, set at the same angle at start-up of the disc.

Either end of the drive shaft **5**, may be connected with a speed step-up belt drive arrangement, which is not shown here.

Plastic deflectors **19**, are added to either side of the oscillation plates **3a**, adjacent to the opposite magnets segments **3b**, and **3c**, their exact position depending on the direction of rotation of disc **2**. These act as an anti-jamming device for the magnets.

Magnetic field bias angles **3f** and **3g** (Fig.3), are required for the sides of plates **3a**, in order to assure an optimum "pull-push" sequence on the large drive disc **2**, as the magnetic oscillation pairs **3**, are actuated. The bias angle **3f**, is matched to the magnet segment **3b**, while bias angle **3g** is matched to magnet segment **3c**.

None of the load components which are external to the device, such as an electric generator or alternator, are shown as a part of this invention, since a variety of load devices and arrangements are possible for the magnetic disc drive.

Bob Neal's Compressed Air Engine

US Patent 2,030,759

11th Feb. 1936

Inventor: Bob Neal

COMPRESSOR UNIT

This invention relates to the construction of a compressor, and more particularly to a combined fluid-operated engine and compressor.

The primary object of the invention, is the provision of a compressor of this character, wherein there is arranged an automatically counterbalanced crankshaft and fluid equalisers within a storage tank, which makes it possible for the engine to operate on constant reserve tank pressure, so as to actuate additional equipment, the pistons for the engine also being automatically balanced and suspended when the engine is operating.

Another object of the invention is the provision of an engine which is operated by air under pressure, the air being supplied by compressors which are in a bank with the engine construction.

A further object of this invention is the provision of an engine of this type of novel construction as the engine and the compressors are operated from the same crankshaft, which is of the automatically balanced type, so that high efficiency is attained.

A still further object of the invention is the provision of an engine of this character which is comparatively simple in construction, thoroughly reliable and efficient in its operation, strong, durable, and inexpensive to manufacture.

With these and other objects in view, the invention consists in the features of construction, combination and arrangement of parts as will be described more fully here, illustrated in the accompanying drawings which disclose the preferred embodiment of the invention, and pointed out in the appended Claim.

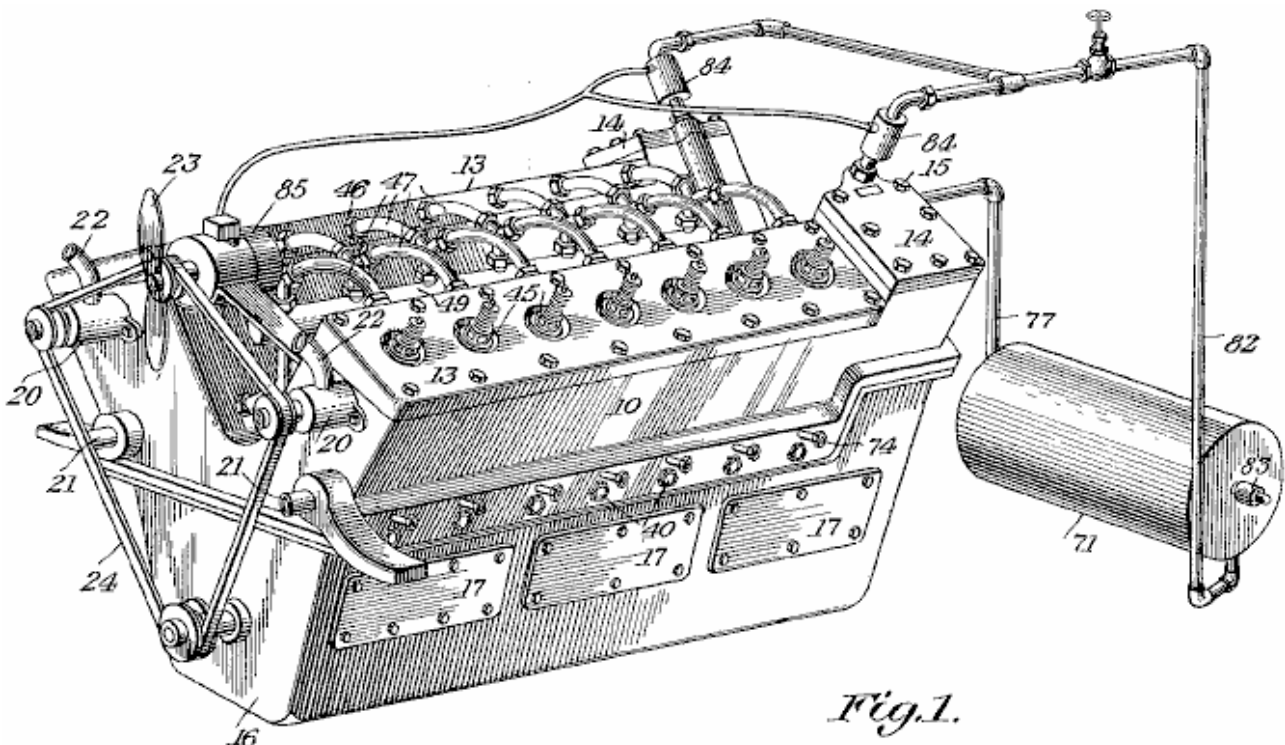

In the drawings, **Fig.1** is a perspective view of the engine constructed in accordance with the invention.

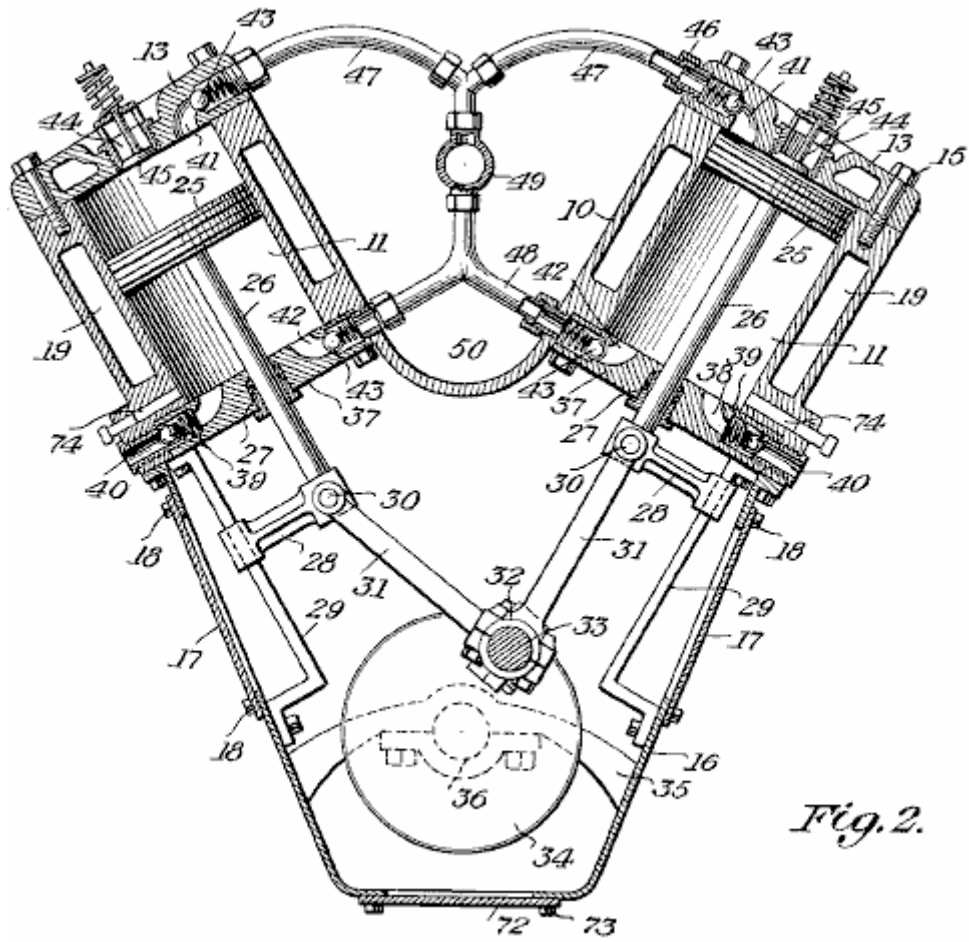

Fig. 2.

Fig. 2 is a vertical transverse cross-section view through the compressor part of the engine.

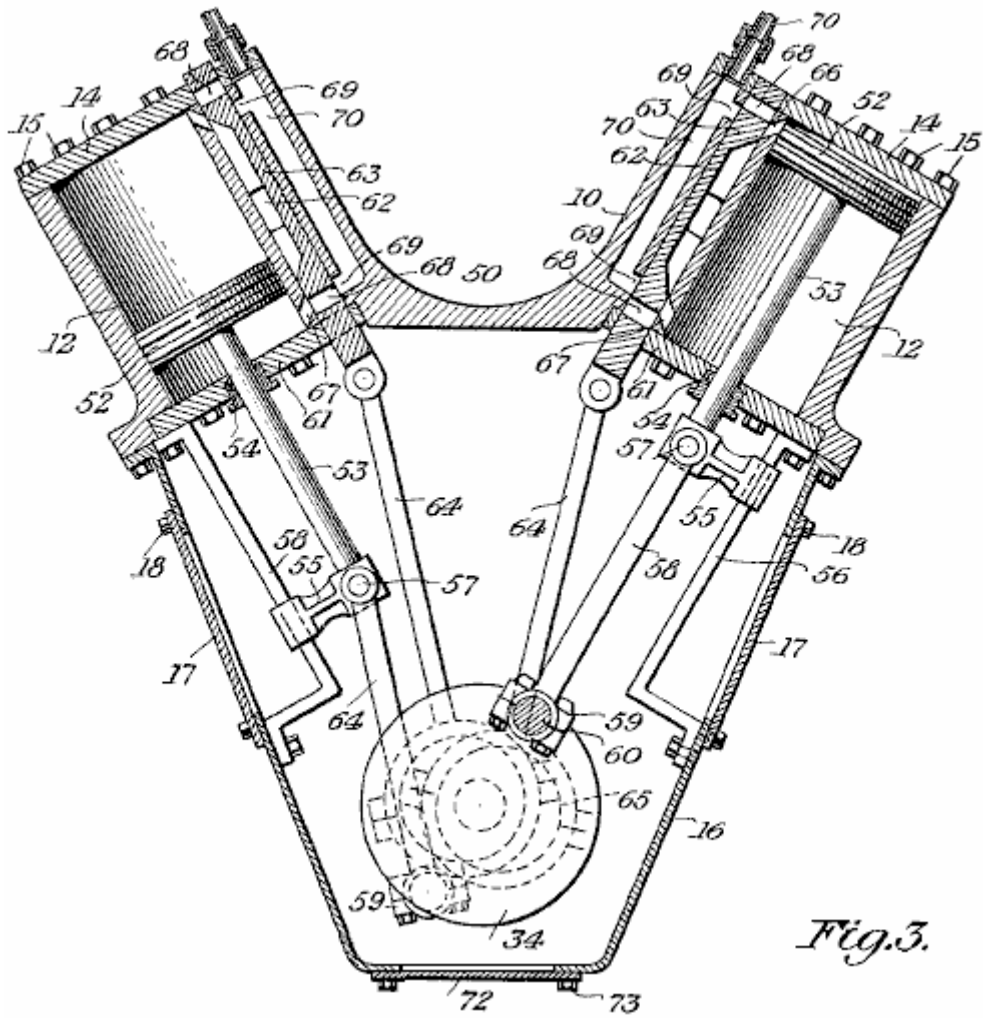

Fig. 3.

Fig. 3 is a vertical cross-sectional view through the power part of the engine.

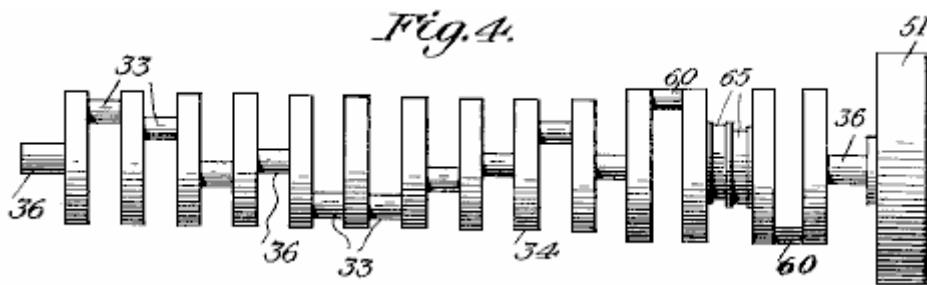

Fig. 4.

Fig. 4 is a detail elevation of the crankshaft of the engine.

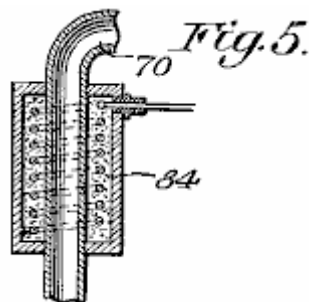

Fig. 5.

Fig. 5 is an enlarged cross-sectional view through one of the electric heaters for the engine.

Fig.6.

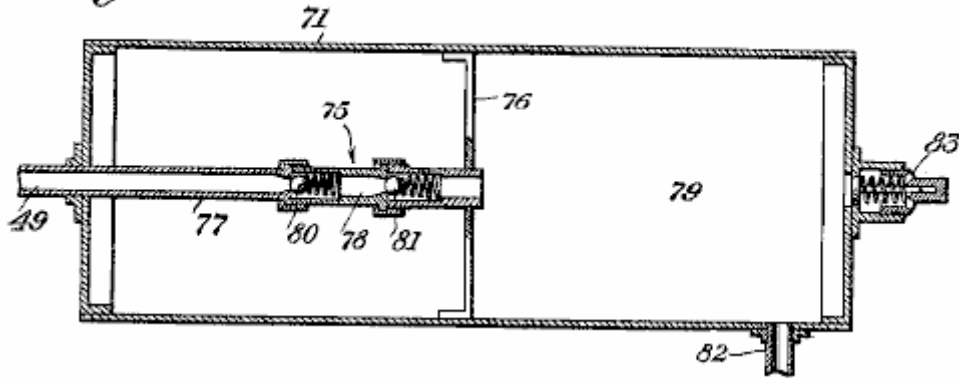

Fig.6 is a vertical, longitudinal, cross-sectional view through the air storage tank, including the equaliser.

The same reference numbers are used for each individual part in every view in every drawing.

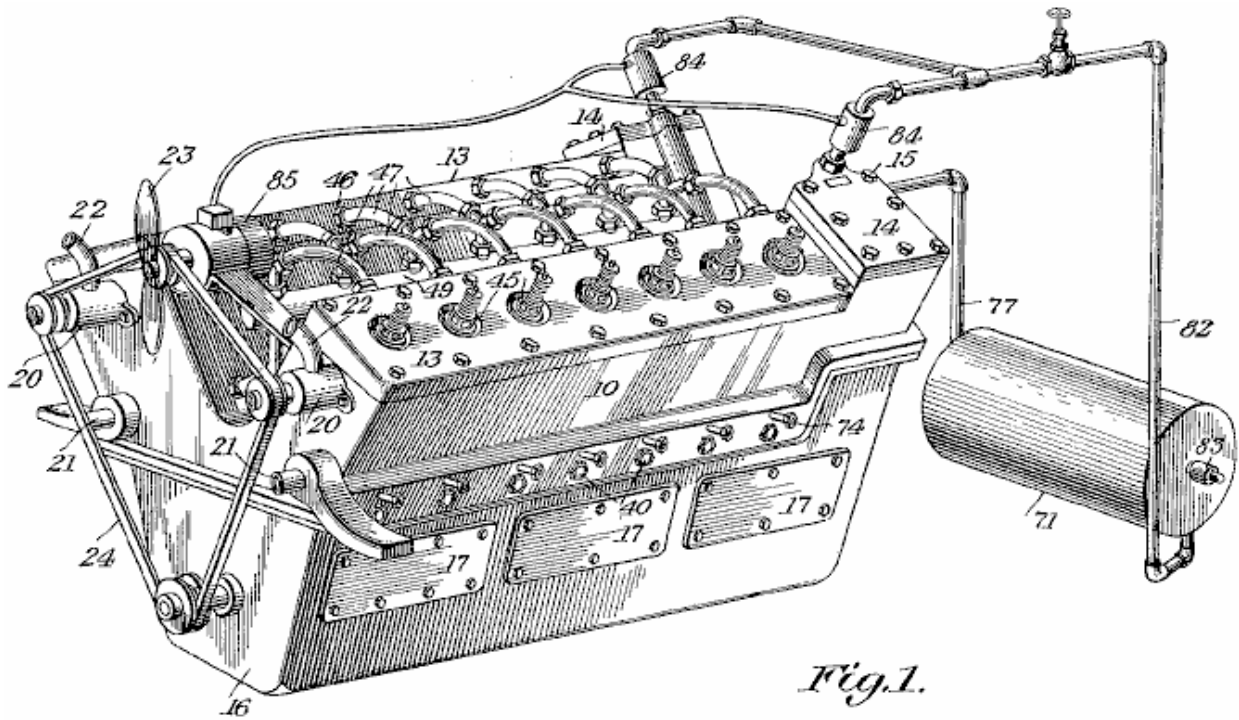

Fig.1.

Referring to the drawings in detail, the engine in its entirety, composes a cylinder block **10** having inside it, the series of compressor cylinders **11** and the power cylinders **12**. The block **10** is of the V-type and the upper ends of the cylinders are closed off by the removable heads **13** and **14** which are held in place by conventional head bolts **15**. Beneath block **10** is the crank case **16**, which has detachable plates **17** at opposite sides, held in place by fasteners **18**, and seated so as to be leak proof. The block **10** is chambered to provide a water jacket **19** surrounding the cylinders, while at the forward end of the block are water pumps **20**, circulating water through the inlet pipe **21** which leads into the jacket and the water exits from the jacket through the outlet pipe **22**. Beside the pumps **20**, is a fan **23** which is operated from the same belt **24** which drives the pumps.

Working inside the cylinders **11**, are the reciprocating pistons **25**, their rods **26** sliding through packing glands **27** and fixed to crossheads **28** which slide on their mounting guides **29** which are secured to the walls of the crank case **16**. These crossheads **28** are fitted with wrist pins **30**, forming a pivoting connection with the connecting rods **31**, which are connected to their cranks **33** by their bearings **32**. The cranks **33** form part of a counter balanced crankshaft **34**, which is mounted in supports **35** attached to the crank case **16**, the shaft being provided with the required bearings **36**.

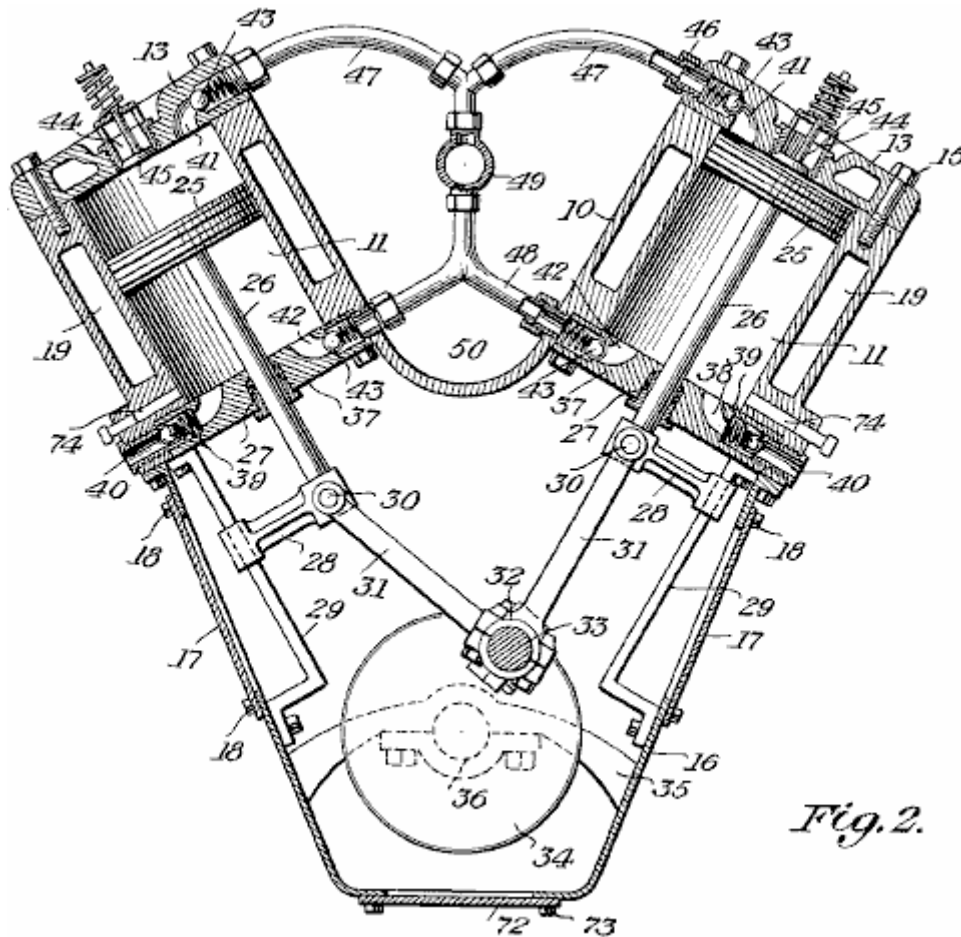

Fig. 2.

The inner ends of the cylinders 11 are fitted with inner end heads 37, which are provided with air intake ports 38 fitted with spring ball inlet checks 39, the air entering through passages 40 which open outside the block 10. Glands 27 are mounted in the heads 37.

The heads 13 and 37 are provided with the compressed air outlets 41 and 42, which are fitted with spring ball checks 43. The heads 13 are also provided with the central air inlets 44, which are fitted with spring checks 45. Couplings 46 attach the air outlets 41 and 42 to their outlet feed pipes 47 and 48. These pipes lead to a main conduit 49 which is located in the centre channel 50 of the block 10.

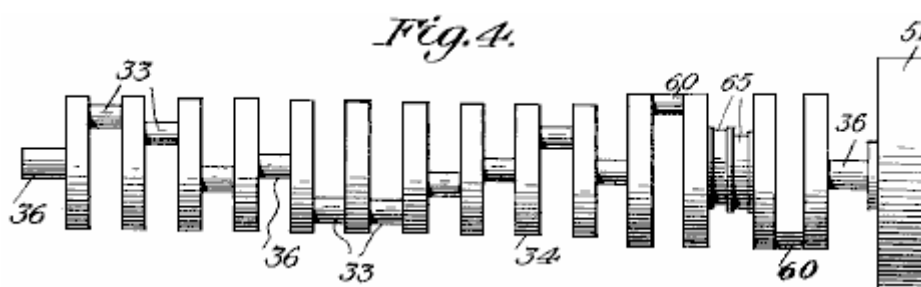

Fig. 4.

At the rear end of the block 10, mounted on shaft 36, there is a conventional flywheel 51.

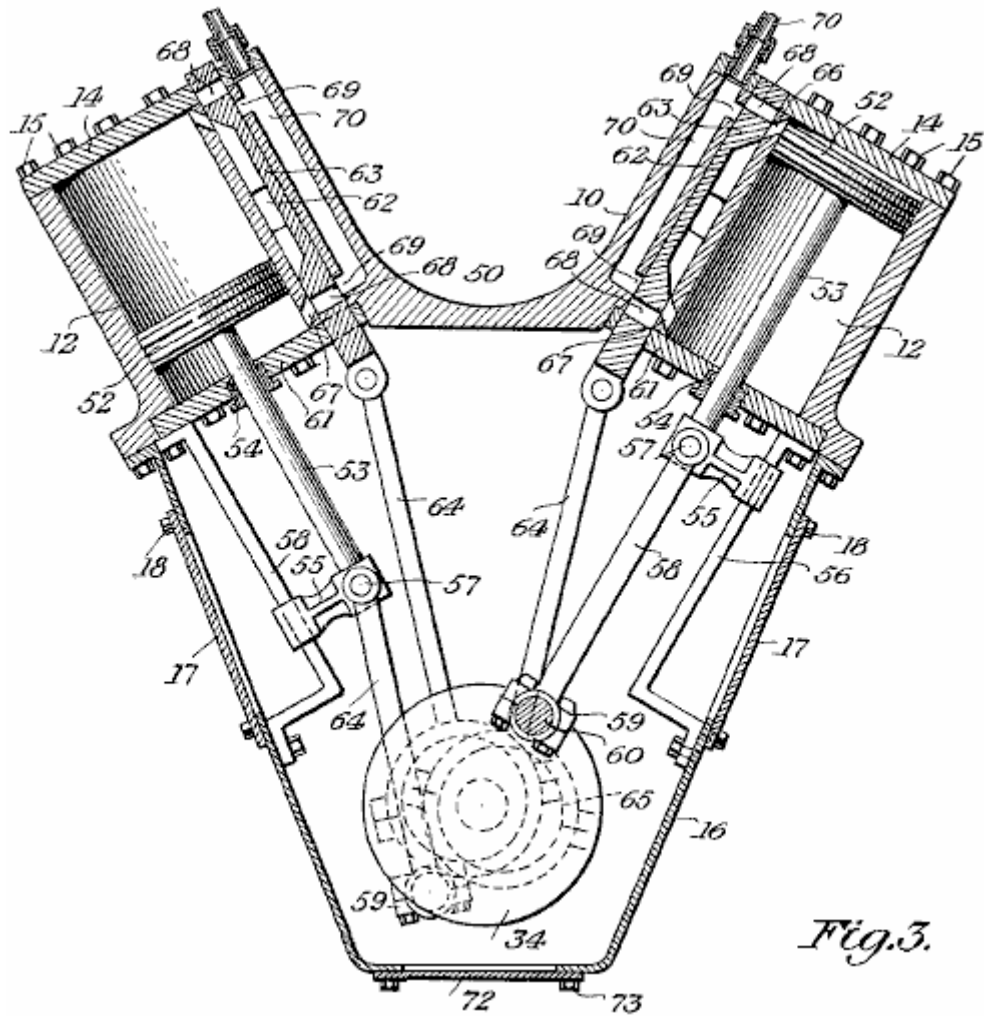
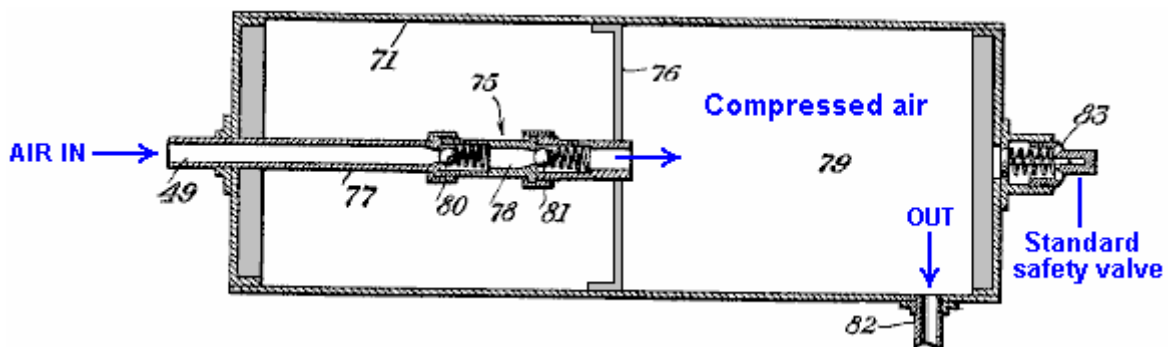

Fig. 3.

Working inside the cylinders **12** are the pistons **52**, with their piston rods **53** sliding through packing glands **54** and fixed in crossheads **55** which slide along their mounting guides **56**, mounted on the inner walls of the crank case **16**. The crossheads **55** have wrist pins **57** which provide a pivoting joint for the connecting rods **58** which are connected by their bearings **59** to their cranks **60** of the crank shaft **34**, the inner ends of the cylinders **12** being closed by the inner heads **61** and their associated glands **54**.

On the cylinders **12** are slide valve chests **62** in which are the slide valves **63**, these being operated by throw rods **64** actuated by cams **65** and the valves controlling the admission and exhaust of air into and out of the cylinders **12**, through the ports **66** and **67**, and these valves **63** are provided with ports **68** for the delivery of air under pressure from the inlet passages **69** common to a pipe **70** coming from a compressed air storage tank **71**.

The bottom of the crank case **16** is fitted with a removable plate **72** which is secured in place by fasteners **73**, and when this plate is removed, it provides access to the crank shaft **34** and the bearings for the engine, as well as other parts inside the crank case.



Leading into the cylinders **11** are the passages **74** of a lubricating system (not shown). The compressed air storage tank **71** has inside it a double-check discharge nozzle **75**, supported by member **76**. Leading to this equaliser is an air inlet pipe **77** which connects through its valved section **78** to the compressed air reservoir **79**.

In the equaliser **75**, are the spaced spring ball checks **80** and **81**, one being for the inlet side and the other for the outlet side of the equaliser. This pipe **77** is connected with the main conduit **49**, while a pipe **82** connects to pipe **70**. The tank is also fitted with an automatic relief valve **83** and this valve can be of any approved type.

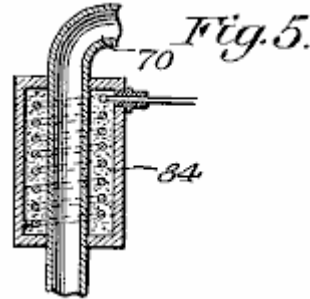

Placed around the pipes **70** which connect to the air passages **69** (Fig.3) are electric heating units **84** to heat the pressurised air to above freezing temperature when delivered from tank **71** to the cylinders **12**. Supported on the block **10** is an electric generator **85** which is driven from the shaft **34** (Fig.2) through a belt **24** (Fig.1) and this generator is included in an electric circuit which also has the heaters **84** so that these will operate from current supplied by the generator.

The compressed air storage tank **71** with the equaliser is constructed so that it is possible to pump air into it while it contains an air pressure of 200 pounds per square inch while the compressors are only pumping against 15 pounds per square inch of (atmospheric) pressure. An outside air pressure source can be coupled with the tank to augment that pressure derived from the cylinders **11** of the engine.

CLAIMS

What is claimed is:

In a structure of the kind described, a V-shaped cylinder block provided with upwardly divergent cylinders, end heads fitted to said cylinders at opposite ends thereof, each head having valved inlets and outlets, a main outlet lead between the cylinders of the block for a storage tank and having lateral branches to the outlets at the inner sides of said heads, one inlet being located at the centre of each head at the outer ends of said cylinders while the remaining inlets are at the outer sides of the heads at the inner ends of said cylinders, a substantially V-shaped crank case fitted to the block beneath the cylinders, a counterbalanced crank shaft journaled in the crank case, pistons operating in the cylinders and having rods extended into the crank case, crosshead guides fitted to the interior sides of said case, crossheads connecting the rods with the guides and sliding on them and connecting rods operated by the crank shaft and pivoted at the crossheads in order to allow reciprocation of the pistons.

Leroy K. Rogers' Compressed Air Engine

Patent US 4,292,804

6th October 1980

Inventor: Leroy K. Rogers

METHOD AND APPARATUS FOR OPERATING AN ENGINE ON COMPRESSED GAS

ABSTRACT

The present invention relates to a method and apparatus for operating an engine having a cylinder containing a reciprocating piston driven by a compressed gas. The apparatus comprises a source of compressed gas connected to a distributor which conveys the compressed gas to the cylinder. A valve is provided to admit compressed gas to the cylinder when the piston is in an approximately Top Dead Centre position.

In one embodiment of the present invention, the timing of the opening of the valve is advanced so that the compressed gas is admitted to the cylinder progressively further before the Top Dead Centre position of the piston as the speed of the engine increases.

In a further embodiment of the present invention, a valve actuator is provided which increases the length of time over which the valve remains open to admit compressed gas to the cylinder as the speed of the engine increases.

A still further embodiment of the present invention relates to an apparatus for adapting a conventional internal combustion engine for operation on compressed gas.

US Patent References:

3,881,399	May., 1975	Sagi et al.	91/187.
3,885,387	May., 1975	Simington	60/407.
4,018,050	Apr., 1977	Murphy	60/412.

DESCRIPTION

BACKGROUND AND SUMMARY OF THE PRESENT INVENTION

The present invention is a method and apparatus for operating an engine using a compressed gas as the motive fluid. More particularly, the present invention relates to a apparatus for adapting a pre-existing internal combustion engine for operation on a compressed gas.

Air pollution is one of the most serious problems facing the world today. One of the major contributors to air pollution is the ordinary internal combustion engine which is used in most motor vehicles today. Various devices, including many items required by legislation, have been proposed in an attempt to limit the pollutants which an internal combustion engine exhausts to the air. However, most of these devices have met with limited success and are often both prohibitively expensive and complex. A clean alternative to the internal combustion engine is needed to power vehicles and other machinery.

A compressed gas, preferably air, would provide an ideal motive fluid for an engine, since it would eliminate the usual pollutants exhausted from an internal combustion engine. An apparatus for converting an internal combustion engine for operation on compressed air is disclosed in U.S. Pat. No. 3,885,387 issued May 27, 1975 to Simington. The Simington patent discloses an apparatus including a source of compressed air and a rotating valve actuator which opens and closes a plurality of mechanical poppet valves. The valves deliver compressed air in timed sequence to the cylinders of an engine through adapters located in the spark plug holes. However, the output speed of an engine of this type is limited by the speed of the mechanical valves and the fact that the length of time over which each of the valves remains open cannot be varied as the speed of the engine increases.

Another apparatus for converting an internal combustion engine for operation on steam or compressed air is disclosed in U.S. Pat. No. 4,102,130 issued July 25, 1978 to Stricklin. The Stricklin patent discloses a device

which changes the valve timing of a conventional four stroke engine such that the intake and exhaust valves open once for every revolution of the engine instead of once every other revolution of the engine. A reversing valve is provided which delivers live steam or compressed air to the intake valves and is subsequently reversed to allow the exhaust valves to deliver the expanded steam or air to the atmosphere. A reversing valve of this type however does not provide a reliable apparatus for varying the amount of motive fluid injected into the cylinders when it is desired to increase the speed of the engine. Further, a device of the type disclosed in the Stricklin patent requires the use of multiple reversing valves if the cylinders in a multi-cylinder engine were to be fired sequentially.

Therefore, it is an object of the present invention to provide a reliable method and apparatus for operating an engine or converting an engine for operation with a compressed gas.

A further object of the present invention is to provide a method and apparatus which is effective to deliver a constantly increasing amount of compressed gas to an engine as the speed of the engine increases.

A still further object of the present invention is to provide a method and apparatus which will operate an engine using compressed gas at a speed sufficient to drive a conventional automobile at highway speeds.

It is still a further object of the present invention to provide a method and apparatus which is readily adaptable to a standard internal combustion engine, to convert the internal combustion engine for operation with a compressed gas.

Another object of the invention is to provide a method and apparatus which utilises cool expanded gas, exhausted from a compressed gas engine, to operate an air-conditioning unit and/or an oil-cooler.

These and other objects are realised by the method and apparatus of the present invention for operating an engine having at least one cylinder containing a reciprocating piston and using compressed gas as the motive fluid. The apparatus includes a source of compressed gas, a distributor connected it for conveying the compressed gas to the cylinder or cylinders. A valve is provided for admitting the compressed gas to the cylinder when the piston is in an approximately Top Dead Centre position within the cylinder. An exhaust is provided for exhausting the expanded gas from the cylinder as the piston returns to approximately the Top Dead Centre position.

In a preferred embodiment of the present invention, a device is provided for varying the duration of each engine cycle over which the valve remains open to admit compressed gas to the cylinder, dependent upon the speed of the engine. In a further preferred embodiment of the present invention, an apparatus for advancing the timing of the opening of the valve is arranged to admit the compressed gas to the cylinder progressively further and further before the Top Dead Centre position of the piston, as the speed of the engine increases.

Further features of the present invention include a valve for controlling the amount of compressed gas admitted to the distributor. Also, a portion of the gas which has been expanded in the cylinder and exhausted through the exhaust valve, is delivered to a compressor to be compressed again and returned to the source of compressed gas. A gear train can be engaged to drive the compressor selectively at different operating speeds, depending upon the pressure maintained at the source of compressed air and/or the speed of the engine. Still further, a second portion of the exhaust gas is used to cool a lubricating fluid for the engine or to operate an air-conditioning unit.

In a preferred embodiment of the present invention, the valve for admitting compressed gas to the cylinder is operated electrically. The device for varying the duration of each engine cycle, over which the intake valve remains open, as the speed of the engine increases, comprises a rotating element whose effective length increases as the speed of the engine increases, causing a first contact on the rotating element to be electrically connected to a second contact on the rotating element, for a longer period of each engine cycle. The second contact operates the valve causing it to remain in an open position for a longer period of each engine cycle, as the speed of the engine increases.

Still further features of the present invention include an adaptor plate for supporting the distributor above the intake manifold of a conventional internal combustion engine after a carburettor has been removed to allow air to enter the cylinders of the engine through the intake manifold and conventional intake valves. Another adaptor plate is arranged over an exhaust passageway of the internal combustion engine to reduce the cross-sectional area of the exhaust passageway.

BRIEF DESCRIPTION OF THE DRAWINGS

Preferred embodiments of a method and apparatus for operating an engine according to the present invention will be described with reference to the accompanying drawings in which components have the same reference numbers in each drawing.

Fig.1 is a schematic representation of an apparatus according to the present invention arranged on an engine:

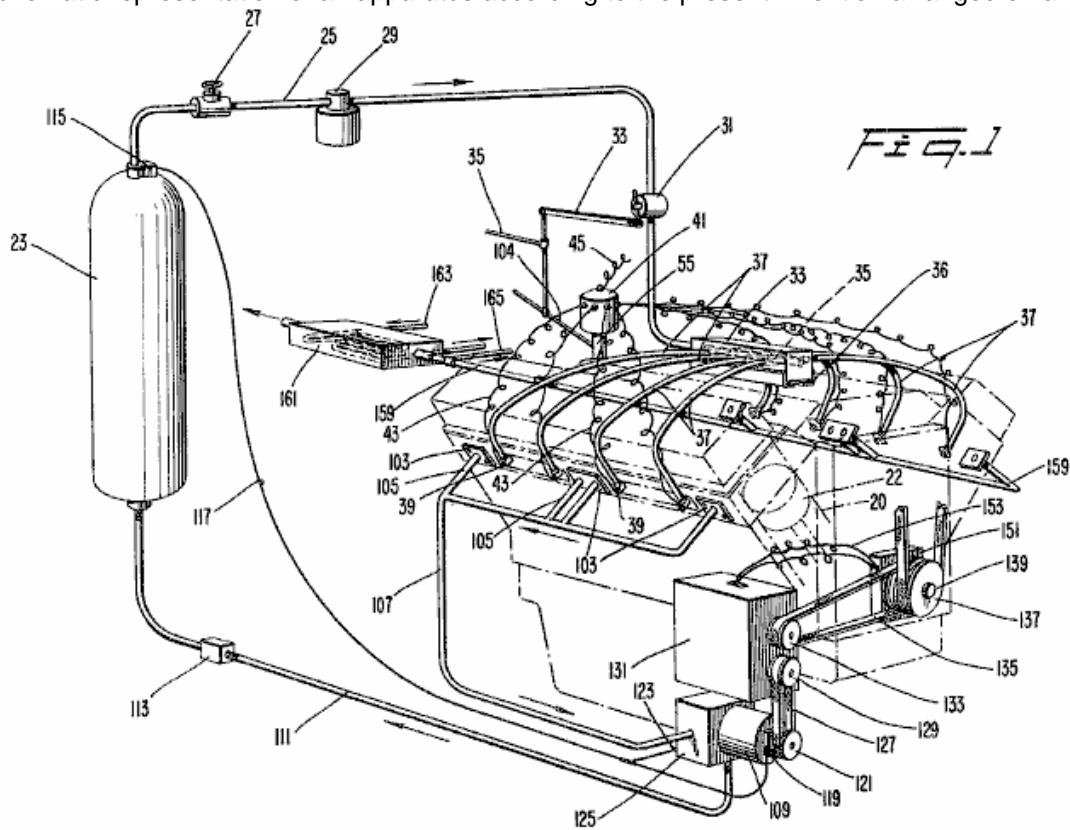

Fig.2 is a side view of one embodiment of a valve actuator according to the present invention.

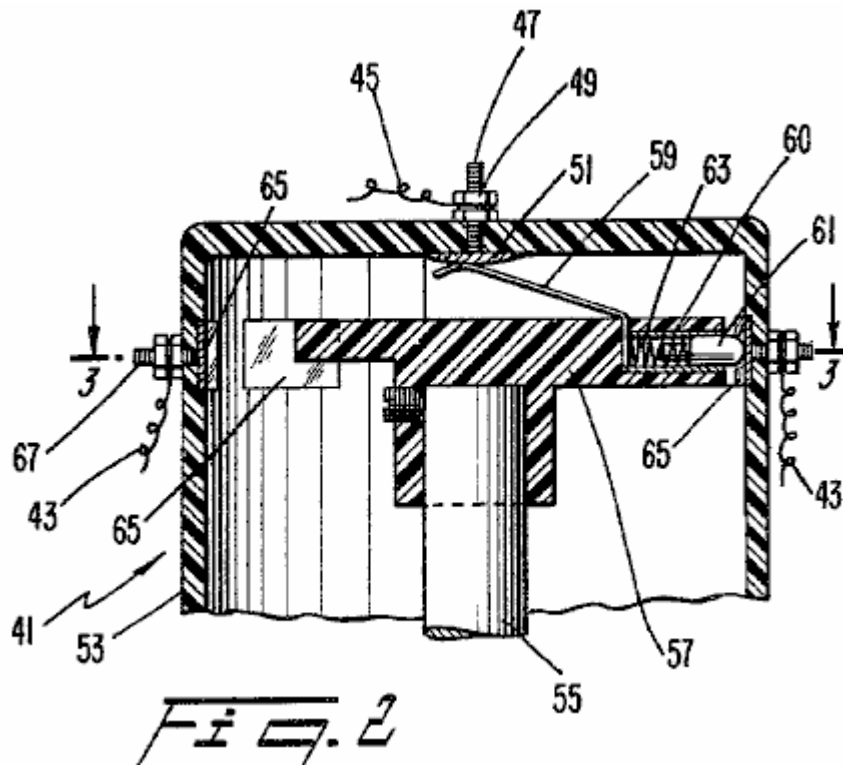

Fig.3 is a cross-sectional view taken along the line 3--3 in Fig.2.

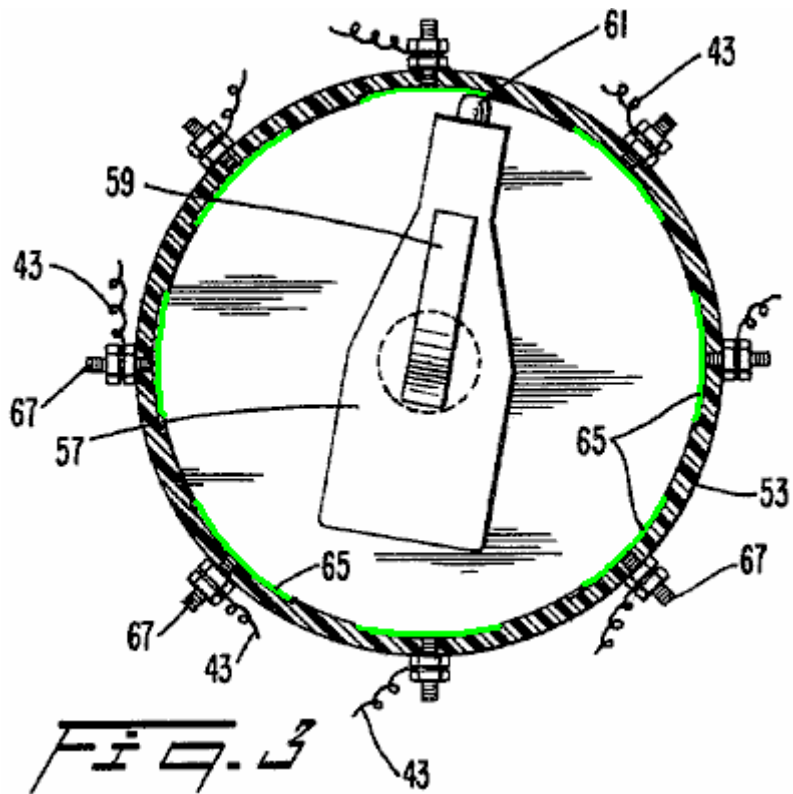

Fig.4 is a cross-sectional view of a second embodiment of a valve actuator according to the present invention.

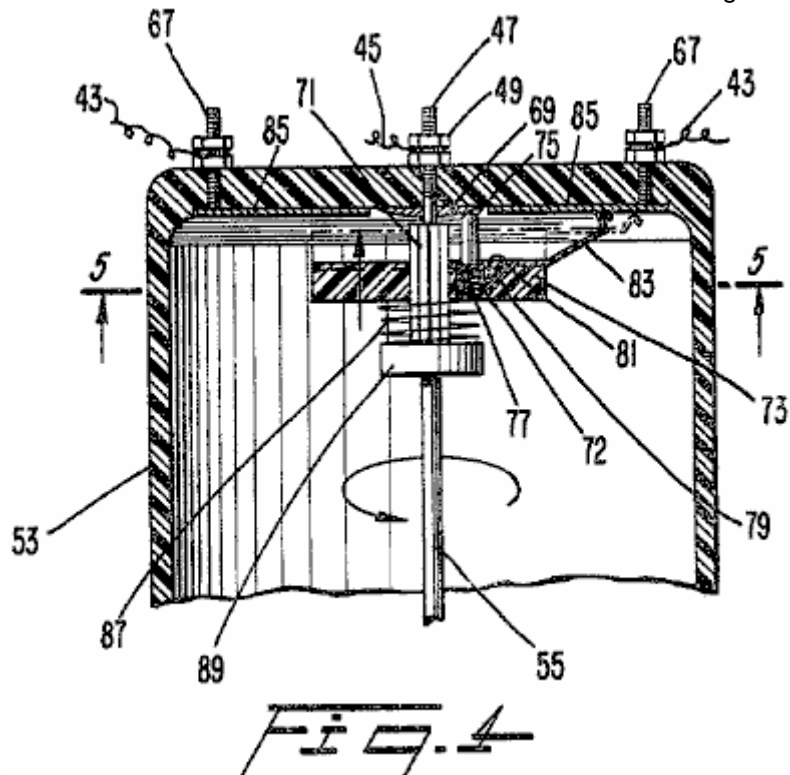

Fig.5 is a view taken along the line 5--5 in Fig.4.

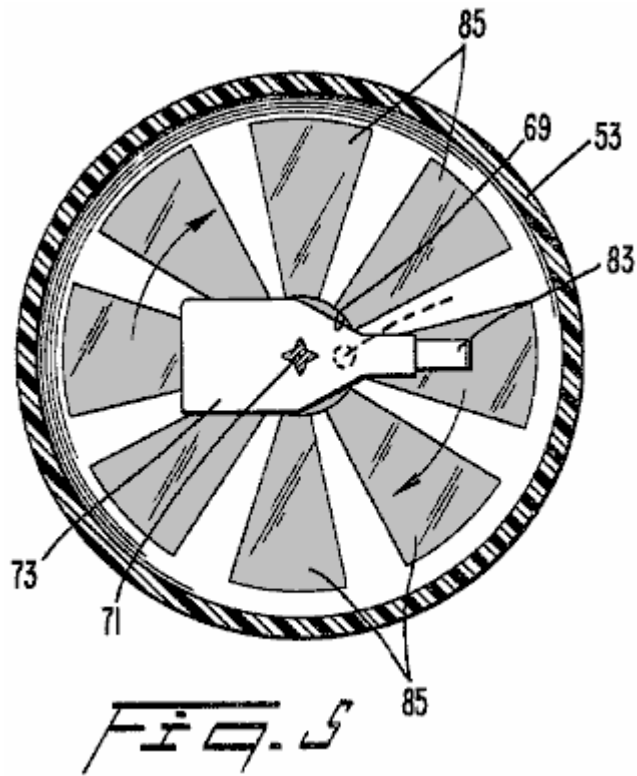

Fig.6 is a cross-sectional view of a third embodiment of a valve actuator according to the present invention;

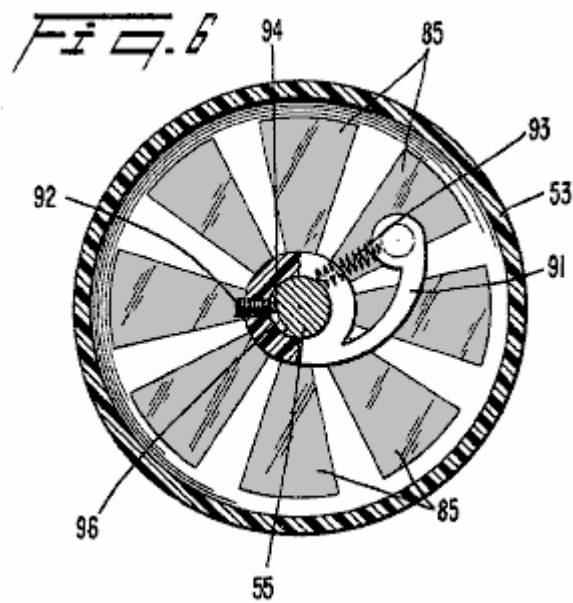

Fig.7 is a view taken along the line 7--7 in Fig.6.

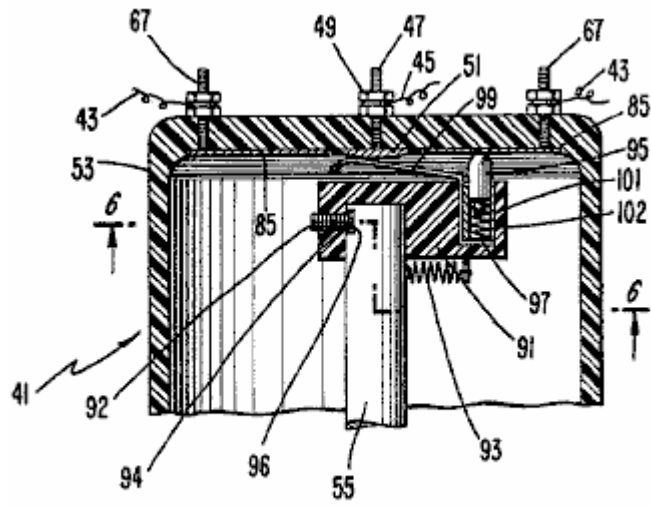
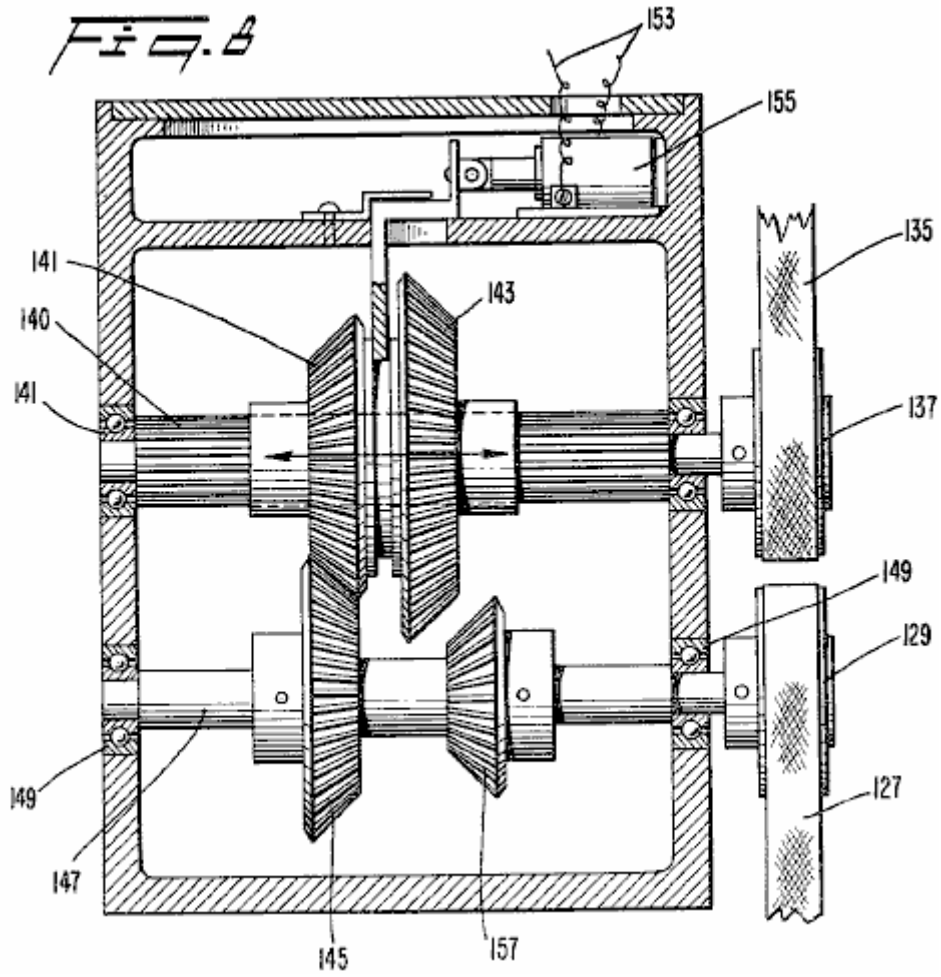

Fig. 7

Fig.8 is a cross-sectional view of a gearing unit to drive a compressor according to the present invention.



DETAILED DESCRIPTION OF THE PREFERRED EMBODIMENTS

With reference to **Fig.1**, an engine block **21** (shown in phantom) having two banks of cylinders with each bank including cylinders **20** having pistons **22** which reciprocate in them in a conventional manner (only one of which is shown in phantom). While the illustrated engine is a V-8 engine, it will be apparent that the present invention is applicable to an engine having any number of pistons and cylinders with the V-8 engine being utilised for illustration purposes only. A compressed gas tank **23** is provided to store a compressed gas at high pressure. It may also be desirable to include a small electric or gas compressor to provide compressed gas to supplement the compressed gas held in the tank **23**. In a preferred embodiment, the compressed gas is air which can be obtained from any suitable source.

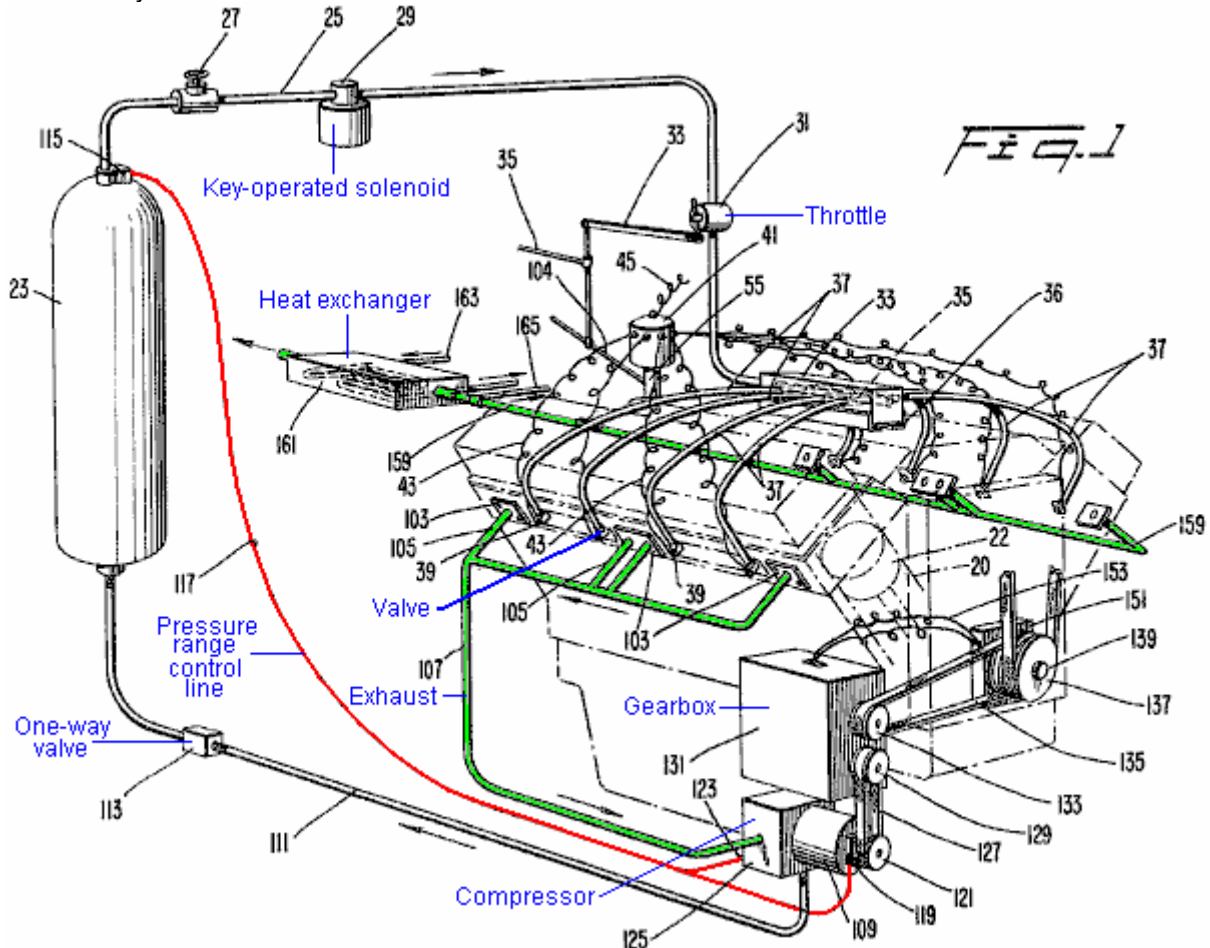

A line **25** transports the gas withdrawn from the tank **23** when a conventional shut-off valve **27** is open. In addition, a solenoid valve **29** preferably operated by a suitable key-operated engine switch (not shown) is also placed in the line **25**. In normal operation, the valve **27** is maintained open at all times with the solenoid valve **29** operating as a selective shut off valve to start and stop the engine **21**.

A suitable regulating valve **31** is arranged downstream of the solenoid valve **29** and is connected by a linkage **33** to a throttle linkage **35** which is operator-actuated by any suitable apparatus such as a foot pedal (not shown). The line **25** enters an end of a distributor **33** and is connected to an end of a pipe **35** which is closed at the other end. A plurality of holes, which are equal to the number of cylinders in the engine **21**, are provided on either side of the pipe **35** along the length of the pipe **35**.

When the present invention is used to adapt a conventional internal combustion engine for operation on compressed gas, an adaptor plate **36** is provided to support the distributor **33** in spaced relation from the usual intake opening in the intake manifold of the engine after a conventional carburettor has been removed. In this way, air is permitted to enter the internal combustion engine through the usual passageways and to be admitted to the cylinders through suitable intake valves (not shown). The adaptor plate **36** is attached to the engine block **21** and the distributor **33** by any suitable apparatus, e.g., bolts.

Each of the holes in the pipe **35** is connected in fluid-tight manner to a single line **37**. Each line **37** carries the compressed gas to a single cylinder **20**. In a preferred embodiment, each of the lines **37** is 1/2 inch high pressure plastic tubing attached through suitable connectors to the distributor **33** and the pipe **35**. Each of the lines **37** is connected to a valve **39** which is secured in an opening provided near the top of each of the cylinders **20**. In the case of a conversion of a standard internal combustion engine, the valves **39** can be conveniently screwed into a

tapped hole in the cylinder **20** typically provided for a spark plug of the internal combustion engine. In a preferred embodiment, the valves **39** are solenoid actuated valves in order to provide a fast and reliable opening and closing of the valves **39**.

Each of the valves **39** is energised by a valve actuator **41** through one of a plurality of wires **43**. The valve actuator **41** is driven by a shaft of the engine similar to the drive for a conventional distributor of an internal combustion engine. That is, a shaft **55** of the valve actuator **41** is driven in synchronism with the engine **21** at one half the speed of the engine **21**.

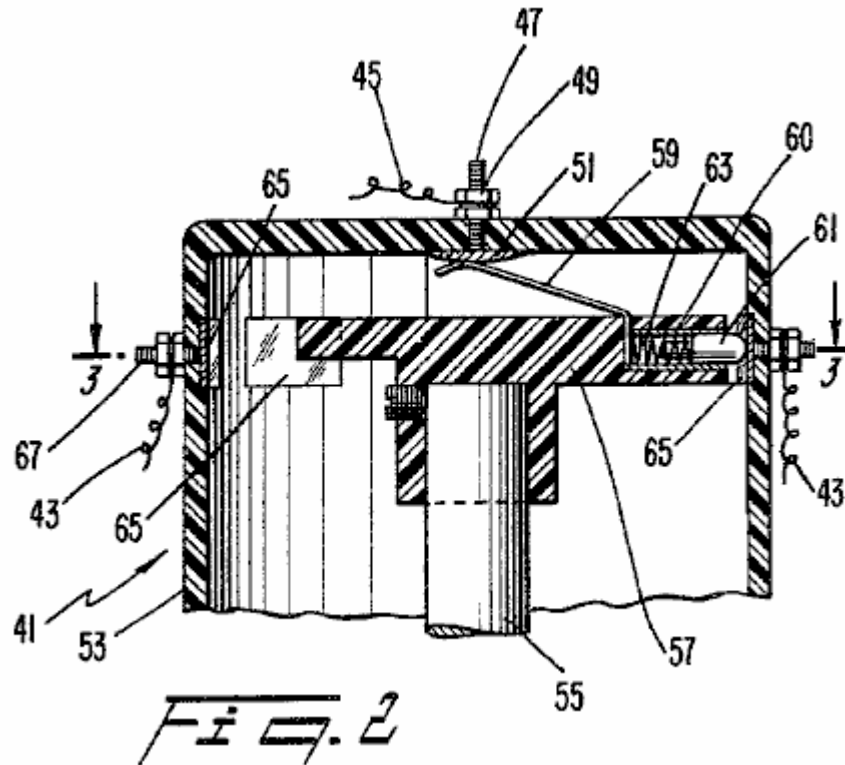

A first embodiment of the valve actuator **41** (**Fig.2** and **Fig.3**), receives electrical power through a wire **45** which is energised in a suitable manner by a battery, and a coil if necessary (not shown) as is conventional in an internal combustion engine. The wire **45** is attached to a central post **47** by a nut **49**. The post **47** is connected to a conducting plate **51** arranged in a housing **53** for the valve actuator **41**. Within the housing **53**, the shaft **55** has an insulating element **57** secured to an end of the shaft **55** and rotates with it when the shaft **55** is driven by the engine **21**. A first end of a flexible contact **59** is continuously biased against the conducting plate **51** to receive electricity from the battery or other suitable source. The other end of the contact **59** is connected to a conducting sleeve **60** which is in constant contact with a spring biased contact **61** which is arranged within the sleeve **60**. The contact **61** is pressed by a spring **63** which pushes contact **61** towards a side wall of the housing **53**.

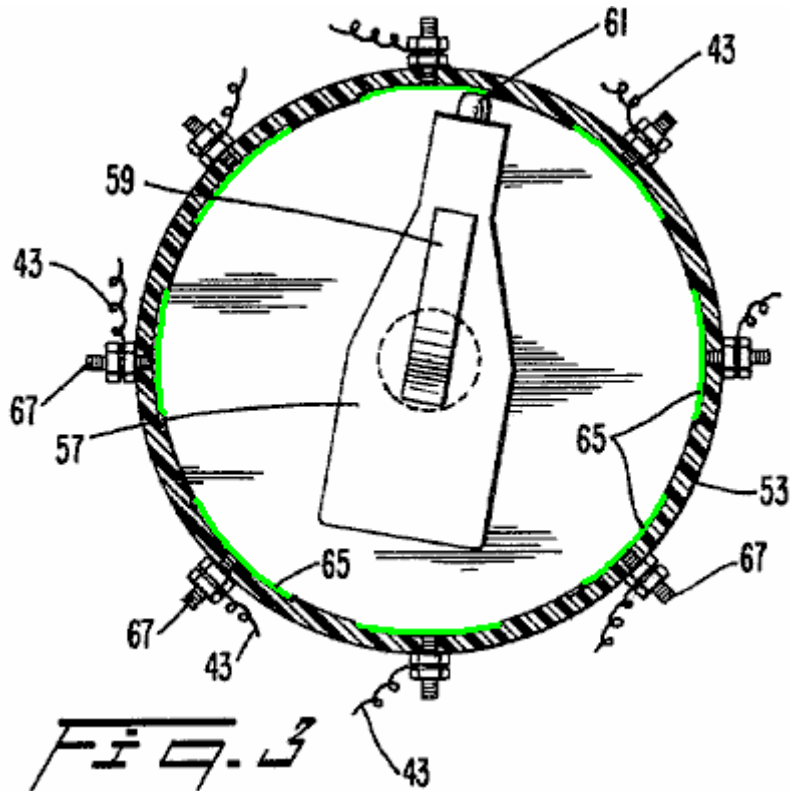

With reference to **Fig.3**, a plurality of contacts **65** are spaced from one another and are arranged around the periphery of the housing **53** at the same level as the spring biased contact **61**. Each contact **65** is electrically connected to a post **67** which extends outside of the housing **53**. The number of contacts **65** is equal to the number of cylinders in the engine **21**. One of the wires **43**, which actuate the valves **39**, is secured to each of the posts **67**.

In operation, as the shaft **55** rotates in synchronism with the engine **21**, the insulating element **57** rotates and electricity is ultimately delivered to successive pairs of the contacts **65** and wires **43** through the spring loaded contact **61** and the flexible contact **59**. In this way, each of the electrical valves **39** is activated and opened in the proper timed sequence to admit compressed gas to each of the cylinders **20** to drive the pistons **22** on a downward stroke.

The embodiment illustrated in **Fig.2** and **Fig.3** is effective in causing each of the valves **39** to remain open for a long enough period of time to admit sufficient compressed gas to each of the cylinders **20** of the engine **21** to drive the engine **21**. The length of each of the contacts **65** around the periphery of the housing **53** is sufficient to permit the speed of the engine to be increased when desired by the operator by moving the throttle linkage **35** which actuates the linkage **33** to further open the regulating valve **31** to admit more compressed gas from the tank **23** to the distributor **33**. However, it has been found that the amount of air admitted by the valves **39** when using the first embodiment of the valve actuator **41** (**Fig.2** and **Fig.3**) is substantially more than required to operate the engine **21** at an idling speed. Therefore, it may be desirable to provide a valve actuator **41** which is capable of varying the duration of each engine cycle over which the solenoid valves **39** are actuated, i.e., remain open to admit compressed gas, as the speed of the engine **21** is varied.

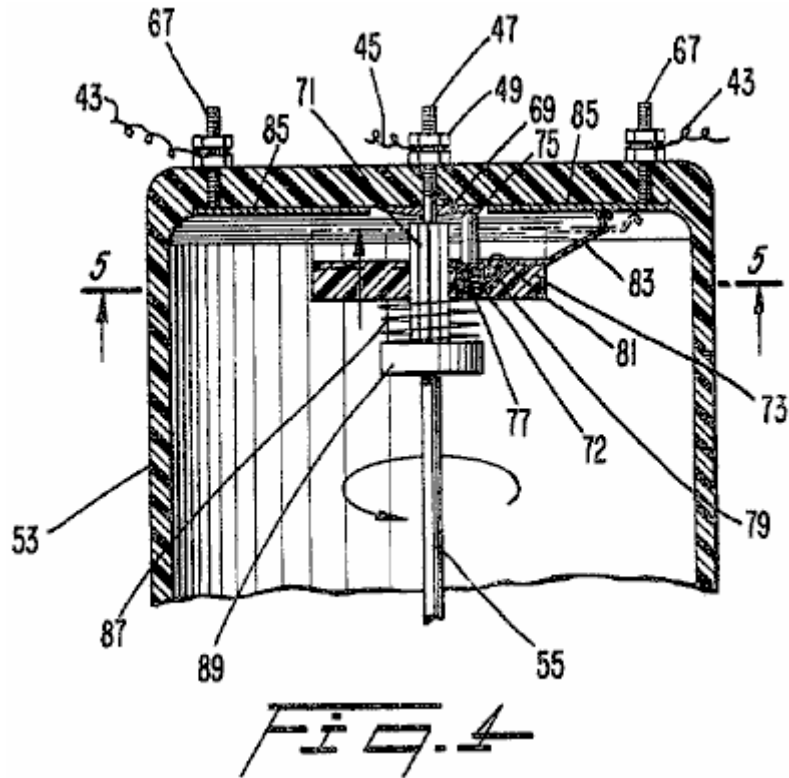

A second embodiment of a valve actuator 41 which is capable of varying the duration of each engine cycle over which each of the valves 39 remains open to admit compressed gas to the cylinders 20 dependent upon the speed of the engine 21 will be described with reference to Fig. 4 and Fig. 5 wherein members corresponding to those of Fig. 2 and Fig. 3 bear like reference numbers. The wire 45 from the electricity source is attached to the post 47 by the nut 49. The post 47 has an annular contact ring 69 electrically connected to an end of the post 47 and arranged within the housing 53. The shaft 55 rotates at one half the speed of the engine as in the embodiment of Fig. 2 and Fig. 3.

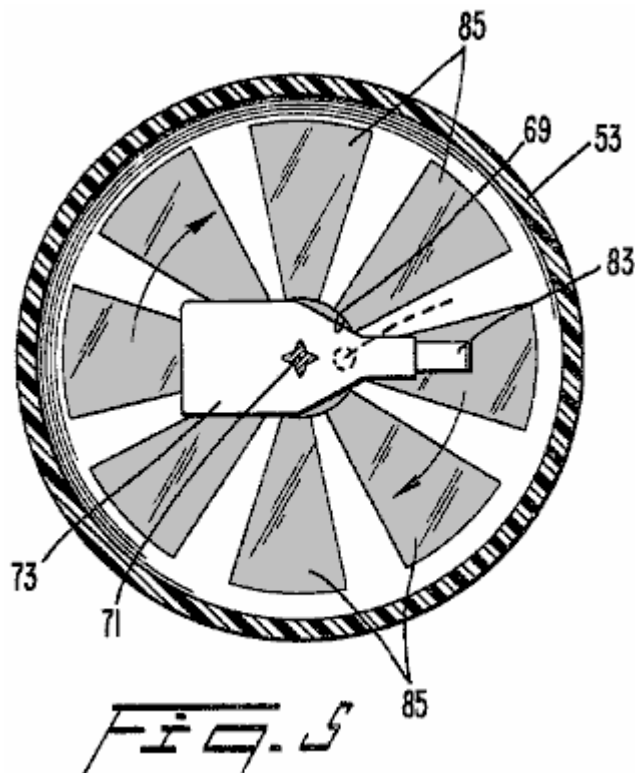

At an upper end of the shaft 55, a splined section 71 receives a sliding insulating member 73. The splined section 71 of the shaft 55 holds the insulating member 73 securely as it rotates with shaft 55 but permits the insulating member 73 to slide axially along the length of the splined section 71. Near the shaft 55, a conductive sleeve 77 is arranged in a bore 81 in an upper surface of the insulating element 73 generally parallel to the splined section 71.

A contact **75**, biased towards the annular contact ring **69** by a spring **77**, is arranged within the conductive sleeve **72** and in contact with it. The conductive sleeve **72** also contacts a conductor **79** at a base of the bore **81**.

The conductor **79** extends to the upper surface of the insulating element **73** near an outer periphery of the insulating element **73** where the conductor **79** is electrically connected to a flexible contact **83**. The flexible contact **83** connects, one after the other, with a series of radial contacts **85** which are positioned on an upper inside surface of the housing **53**. A weak spring **87** arranged around the splined section **71** engages a stop member **89** secured on the shaft **55** and the insulating element **73** to slightly bias the insulating element **73** towards the upper inside surface of the housing **53** to ensure contact between the flexible contact **83** and the upper inside surface of the housing **53**. As best seen in **Fig.5**, the radial contacts **85** on the upper inside surface of the housing **53** are arranged generally in the form of radial spokes extending from the centre of the housing **53** with the number of contacts being equal to the number of cylinders **20** in the engine **21**. The number of degrees covered by each of the radial contacts **85** gradually increases as the distance from the centre of the upper inside surface of the housing **53** increases.

In operation of the device of **Fig.4** and **Fig.5**, as the shaft **55** rotates, electricity flows along a path through the wire **45** down through post **47** to the annular contact member **69** which is in constant contact with the spring biased contact **75**. The electrical current passes through the conductive sleeve **72** to the conductor **79** and then to the flexible contact **83**. As the flexible contact **83** rotates along with the insulating member **73** and the shaft **55**, the tip of the flexible contact **83** successively engages each of the radial contacts **85** on the upper inside of the housing **53**. As the speed of the shaft **55** increases, the insulating member **73** and the flexible contact **83** attached to it, move upwards along the splined section **71** of the shaft **55** due to the radial component of the splines in the direction of rotation under the influence of centrifugal force. As the insulating member **73** moves upwards, the flexible contact **83** is bent so that the tip of the contact **83** extends further outwards radially from the centre of the housing **53** (as seen in phantom lines in **Fig.4**). In other words, the effective length of the flexible contact **83** increases as the speed of the engine **21** increases.

As the flexible contact **83** is bent and the tip of the contact **83** moves outwards, the tip remains in contact with each of the radial contacts **85** for a longer period of each engine cycle due to the increased angular width of the radial contacts with increasing distance from the centre of the housing **53**. In this way, the length of time over which each of the valves **39** remains open is increased as the speed of the engine is increased. Thus, a larger quantity of compressed gas or air is injected into the cylinders as the speed increases. Conversely, as the speed decreases and the insulating member **73** moves downwards along the splined section **71**, a minimum quantity of air is injected into the cylinder due to the shorter length of the individual radial contact **85** which is in contact with the flexible contact **83**. In this way, the amount of compressed gas that is used during idling of the engine **21** is at a minimum whereas the amount of compressed gas which is required to increase the speed of the engine **21** to a level suitable to drive a vehicle on a highway is readily available.

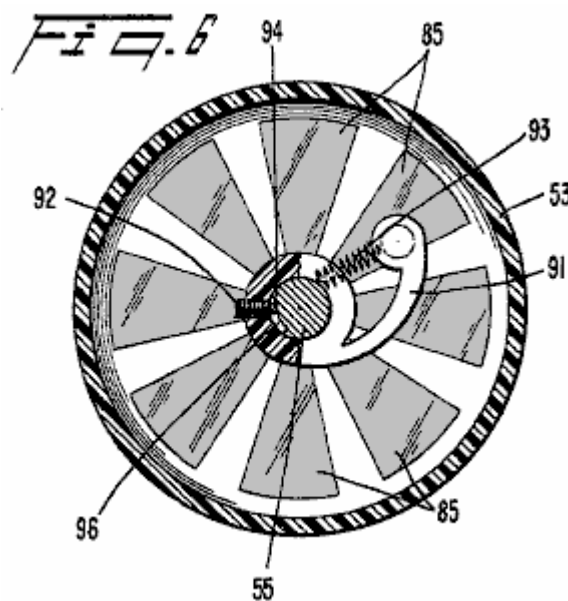

Shown in **Fig.6** and **Fig.7**, is a third embodiment of a valve actuator **41** according to the present invention. This embodiment includes a curved insulating element **91** having its first end able to pivot, being secured by any suitable device such as screw **92** to the shaft **55** for co-rotation with the shaft **55**. The screw **92** is screwed into a tapped hole in the insulating element **91** so that a tab **94** at an end of the screw **92** engages a groove **96** provided in the shaft **55**. In this way, the insulating element **91** rotates positively with the shaft **55**. However, as the shaft **55**

rotates faster, the other end **98** of the insulating element **91** is permitted to pivot outwards under the influence of centrifugal force because of the groove **96** provided in the shaft **55**. A spring **93**, connected between the second end **98** of the element **91** and the shaft **55** urges the second end of the element **91** towards the centre of the housing **53**.

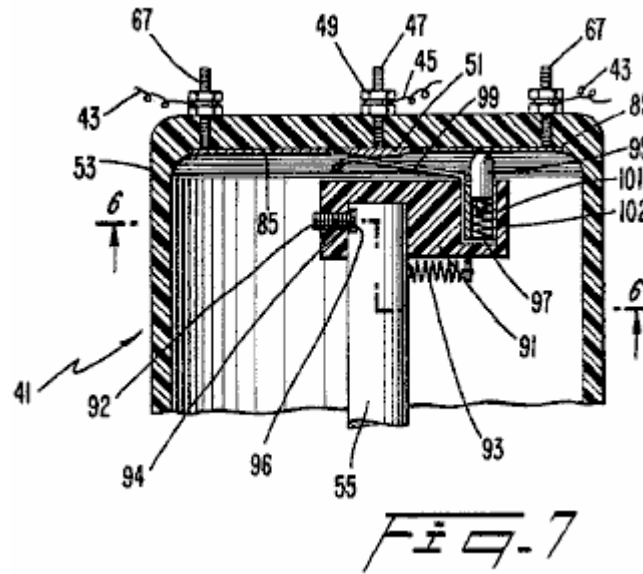

A contact **99** similar to the contact **59** (Fig.2) is arranged so that one end of the contact piece **99** is in constant contact with the conducting plate **51** located centrally within the housing **53**. The other end of the contact **99** engages a conductive sleeve **101** arranged in bore **102**. A contact element **95** is arranged in the conductive sleeve **101** in constant contact with the sleeve **101**. The bore **102** is arranged generally parallel to the shaft **55** near the second end of the curved insulating element **91**. The contact **95** is biased by a spring **97** towards the upper inside surface of the housing **53** for selective contact with each of the plurality of radial contacts **85** which increase in arc length towards the outer peripheral surface of the housing **53** (Fig.6).

When the device shown in **Fig.6** and **Fig.7** is operating, as the shaft **55** rotates the curved insulating element **91** rotates with the shaft **55** and the second end **98** of the insulating element **91** tends to pivot about the shaft **55** due to centrifugal force. Thus, as the effective length of the contact **95** increases, i.e., as the curved insulating element **91** pivots further outwards, the number of degrees of rotation over which the contact **95** is in contact with each of the radial contacts **85** on the upper inside surface of the housing **53** increases thereby allowing each of the valves **39** to remain open for a longer period of each engine cycle, which in turn, allows more compressed gas enter the respective cylinder **20** to further increase the speed of the engine **21**.

With reference to **Fig.1**, a mechanical advance linkage **104** which is connected to the throttle linkage **35**, advances the initiation of the opening of each valve **39** such that compressed gas is injected into the respective cylinder further before the piston **22** in the respective cylinder **20** reaches a Top Dead Centre position as the speed of the engine is increased by moving the throttle linkage **35**. The advance linkage **104** is similar to a conventional standard mechanical advance employed on an internal combustion engine. In other words, the linkage **104** varies the relationship between the angular positions of a point on the shaft **55** and a point on the housing **53** containing the contacts. Alternatively, a conventional vacuum advance could also be employed. By advancing the timing of the opening of the valves **39**, the speed of the engine can more easily be increased.

The operation of the engine cycle according to the present invention will now be described. The compressed gas injected into each cylinder of the engine **21** drives the respective piston **22** downwards to rotate a conventional crankshaft (not shown). The movement of the piston downwards causes the compressed gas to expand rapidly and cool. As the piston **22** begins to move upwards in the cylinder **20** a suitable exhaust valve (not shown), arranged to close an exhaust passageway, is opened by any suitable apparatus. The expanded gas is then expelled through the exhaust passageway. As the piston **22** begins to move downwards again, a suitable intake valve opens to admit ambient air to the cylinder. The intake valve closes and the ambient air is compressed on the subsequent upward movement of the piston until the piston reaches approximately the Top Dead Centre position at which time the compressed gas is again injected into the cylinder **20** to drive the piston **22** downwards and the cycle begins again.

In the case of adapting a conventional internal combustion engine for operation on compressed gas, a plurality of plates **103** are arranged, preferably over an end of the exhaust passageways, in order to reduce the outlet size of the exhaust passageways of the conventional internal combustion engine. In the illustrated embodiment, a single

plate having an opening in the centre is bolted to the outside exhaust passageway on each bank of the V-8 engine, while another single plate having two openings in it, is arranged with one opening over each of the interior exhaust passageways on each bank of the V-8 engine. A line **105** is suitably attached to each of the adaptor plates to carry the exhaust to an appropriate location. In a preferred embodiment, the exhaust lines **105** are made from 1.5" plastic tubing.

In a preferred embodiment, the exhaust lines **105** of one bank of the V-8 engine are collected in a line **107** and fed to an inlet of a compressor **109**. The pressure of the exhaust gas emanating from the engine **21** according to the present invention is approximately 25 p.s.i. In this way, the compressor **109** does not have to pull the exhaust into the compressor since the gas exhausted from the engine **21** is at a positive pressure. The positive pressure of the incoming fluid increases the efficiency and reduces wear on the compressor **109**. The exhaust gas is compressed in the compressor **109** and returned through a line **111** and a check valve **113** to the compressed gas storage tank **23**. The check valve **113** prevents the flow of compressed gas stored in the tank **23** back towards the compressor **109**.

A suitable pressure sensor **115** is arranged at an upper end of the tank **23** and sends a signal along a line **117** when the pressure exceeds a predetermined level and when the pressure drops below a predetermined level. The line **117** controls an electrically activated clutch **119** positioned at the front end of the compressor **109**. The clutch **119** is operated to engage and disengage the compressor **109** from a drive pulley **121**. Also, the signal carried by the line **117** activates a suitable valve **123** arranged on compressor housing **125** to exhaust the air entering the compressor housing **125** from the line **107** when the clutch **119** has disengaged the compressor **109** from the drive pulley **121**.

In a preferred embodiment, when the pressure in the tank **23** reaches approximately 600 p.s.i., the clutch **119** is disengaged and the compressor **109** is deactivated and the valve **123** is opened to exhaust the expanded gas delivered to the compressor **109** from the line **107** to the atmosphere. When the pressure within the tank **23** drops below approximately 500 p.s.i., the sensor **115** sends a signal to engage the clutch **119** and close the valve **123**, thereby operating the compressor **109** for supplying the tank **23** with compressed gas.

The pulley **121** which drives the compressor **109** through the clutch **119** is driven by a belt **127** which is driven by a pulley **129** which operates through a gear box **131**. With reference to **Fig.1** and **Fig.8**, a second pulley **133** on the gear box is driven by a belt **135** from a pulley **137** arranged on a drive shaft **139** of the engine **21**. The pulley **137** drives a splined shaft **140** which has a first gear **141** and a second larger gear **143** placed on it, which rotates with the splined shaft **140**. The splined shaft **140** permits axial movement of the gears **141** and **143** along the shaft **140**.

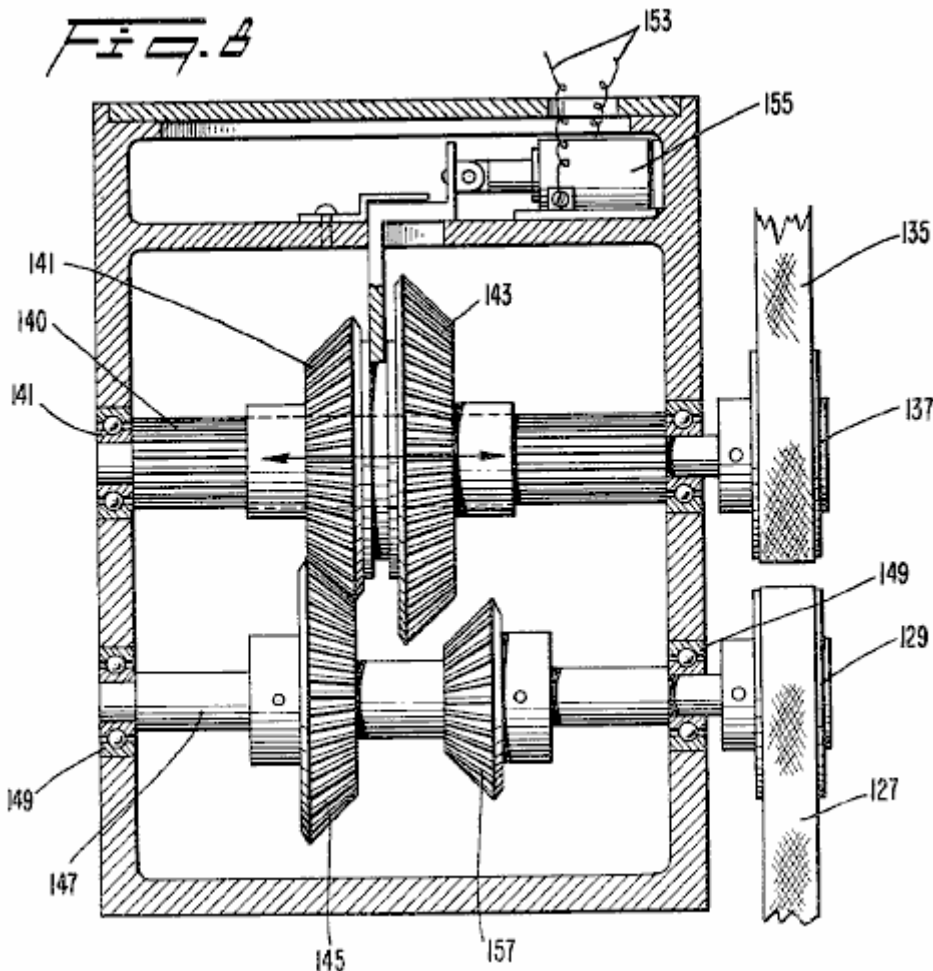

In normal operation (as seen in **Fig.8**), the first gear **141** engages a third gear **145** arranged on a shaft **147** which drives the pulley **129**. The shafts **140** and **147** are arranged in suitable bearings **149** positioned at each end of it. When the speed of the engine **21** drops below a predetermined level, a suitable sensor **151** responsive to the speed of the drive shaft **139** of the engine **21** generates a signal which is transmitted through a line **153** to a solenoid actuator **155** arranged within the gear box **131**. The solenoid actuator **155** moves the first and second gears **141**, **143** axially along the splined shaft **140** to the right as seen in **Fig.8** so that the second, larger gear **143** engages a fourth smaller gear **157** which is arranged on the shaft **147**. The ratio of the second gear **143** to the fourth gear **157** is preferably approximately 3 to 1.

In this way, when the speed of the engine **21** drops below the predetermined level as sensed by the sensor **151** (which predetermined level is insufficient to drive the compressor **109** at a speed sufficient to generate the 500-600 pounds of pressure which is preferably in the tank **23**), the solenoid actuator **155** is energized to slide the gears **143**, **141** axially along the splined shaft **140** so that the second, larger gear **143** engages the fourth, smaller gear **157** to drive the pulley **129** and hence the compressor **109** at a higher rate, to generate the desired pressure. When the speed of the engine increases above the predetermined level, which, in a preferred embodiment is approximately 1500 rpm, the solenoid actuator **155** is deactivated by the sensor **151** thereby moving the gears **143** and **141** to the left as seen in **Fig.8** so that the first gear **141**, engages again with the third gear **145** to effectuate a 1 to 1 ratio between the output shaft **139** of the engine **21** and the pulley **129**.

The other bank of the V-8 engine has its exhaust ports arranged with adapter plates **103** similar to those on the first bank. However, the exhaust from this bank of the engine **21** is not collected and circulated through the compressor **109**. In a preferred embodiment, a portion of the exhaust is collected in a line **159** and fed to an enlarged chamber **161**. A second fluid is fed through a line **163** into the chamber **161** to be cooled by the cool exhaust emanating from the engine **21** in the line **159**. The second fluid in the line **163** may be either transmission fluid contained in a transmission associated with the engine **21** or a portion of the oil used to lubricate the engine **21**. A second portion of the exhaust from the second bank of the V-8 engine is removed from the line **159** in a line **165** and used as a working fluid in an air conditioning system or for any other suitable use.

It should be noted that the particular arrangement utilised for collecting and distributing the gas exhausted from the engine **21** would be determined by the use for which the engine is employed. In other words, it may be

advantageous to rearrange the exhaust tubing such that a larger or smaller percentage of the exhaust is routed through the compressor **109**. It should also be noted that since the exhaust lines **105** are plastic tubing, a rearrangement of the lines for a different purpose is both simple and inexpensive.

In operation of the engine of the present invention, the engine **21** is started by energising the solenoid valve **29** and any suitable starting device (not shown), e.g., a conventional electric starter as used on an internal combustion engine. Compressed gas from the full tank **23** flows through the line **25** and a variable amount of the compressed gas is admitted to the distributor **33** by controlling the regulator valve **31** through the linkage **33** and the operator actuated throttle linkage **35**. The compressed gas is distributed to each of the lines **37** which lead to the individual cylinders **20**. The compressed gas is admitted to each of the cylinders **20** in timed relationship to the position of the pistons within the cylinders by opening the valves **39** with the valve actuator **41**.

When it is desired to increase the speed of the engine, the operator moves the throttle linkage **35** which simultaneously admits a larger quantity of compressed gas to the distributor **33** from the tank **23** by further opening the regulator valve **31**. The timing of the valve actuator **41** is also advanced through the linkage **104**. Still further, as the speed of the engine **21** increases, the effective length of the rotating contact **83** (**Fig.4**) or **95** (**Fig.6**) increases thereby electrically contacting a wider portion of one of the stationary radial contacts **85** to cause each of the valves **39** to remain open for a longer period of each engine cycle to admit a larger quantity of compressed gas to each of the cylinders **20**.

As can be seen, the combination of the regulating valve **31**, the mechanical advance **104**, and the valve actuator **41**, combine to produce a compressed gas engine which is quickly and efficiently adaptable to various operating speeds. However, all three of the controls need not be employed simultaneously. For example, the mechanical advance **104** could be utilised without the benefit of one of the varying valve actuators **41** but the high speed operation of the engine may not be as efficient. By increasing the duration of each engine cycle over which each of the valves **39** remains open to admit compressed gas to each of the cylinders **20** as the speed increases, conservation of compressed gas during low speed operation and efficient high speed operation are both possible.

After the compressed gas admitted to the cylinder **20** has forced the piston **22** downwards within the cylinder to drive the shaft **139** of the engine, the piston **22** moves upwards within the cylinder **20** and forces the expanded gas out through a suitable exhaust valve (not shown) through the adapter plate **103** (if employed) and into the exhaust line **105**. The cool exhaust can then be collected in any suitable arrangement to be compressed and returned to the tank **23** or used for any desired purpose including use as a working fluid in an air conditioning system or as a coolant for oil.

When using the apparatus and method of the present invention to adapt a ordinary internal combustion engine for operation with compressed gas it can be seen that considerable savings in weight are achieved. For example, the ordinary cooling system including a radiator, fan, hoses, etc. can be eliminated since the compressed gas is cooled as it expands in the cylinder. In addition, there are no explosions within the cylinder to generate heat. Further reductions in weight are obtained by employing plastic tubing for the lines which carry the compressed gas between the distributor and the cylinders and for the exhaust lines. Once again, heavy tubing is not required since there is little or no heat generated by the engine of the present invention. In addition, the noise generated by an engine according to the present invention is considerably less than that generated by an ordinary internal combustion engine since there are no explosions taking place within the cylinders.

The principles of preferred embodiments of the present invention have been described in the foregoing specification. However, the invention which is intended to be protected is not to be construed as limited to the particular embodiments disclosed. The embodiments are to be regarded as illustrative rather than restrictive. Variations and changes may be made by others without departing from the spirit of the invention. Accordingly, it is expressly intended that all such variations and changes which fall within the spirit and the scope of the present invention as defined in the appended claims be embraced thereby.

Eber Van Valkinburg's Compressed Fluid Engine

Patent US 3,744,252

10th July 1973

Inventor: Eber Van Valkinburg

CLOSED MOTIVE POWER SYSTEM UTILISING COMPRESSED FLUIDS

ABSTRACT

Stored energy in a compressed elastic fluid is utilised in a controlled manner to pressurise an inelastic fluid and to maintain such pressurisation. The pressurised inelastic fluid is throttled to the impeller of a prime mover. Only a portion of the output energy from the prime mover is utilised to circulate the inelastic fluid so as to maintain a nearly constant volumetric balance in the system.

DESCRIPTION

The objective of the invention is to provide a closed-loop power system which utilises the expansive energy of a compressed elastic fluid, such as air, to pressurise and maintain pressurised throughout the operational cycle of the system a second non-elastic and non-compressible fluid, such as oil. The pressurised non-elastic fluid is released in a controlled manner by a throttle to the rotary impeller of a turbine or the like, having an output shaft. This shaft is coupled to a pump for the non-elastic fluid which automatically maintains the necessary circulation needed for the operation of the prime mover, and maintains a near volumetric balance in the system between the two fluids which are separated by self-adjusting free piston devices. The pump for the non-elastic fluid includes an automatic by-pass for the non-elastic fluid which eliminates the possibility of starving the pump which depends on the discharge of the non-elastic fluid at low pressure from the exhaust of the turbine. Other features and advantages of the invention will become apparent during the course of the following detailed description.

BRIEF DESCRIPTION OF DRAWING FIGURES

Fig.1 is a partly schematic cross-sectional view of a closed motive power system embodying the invention.

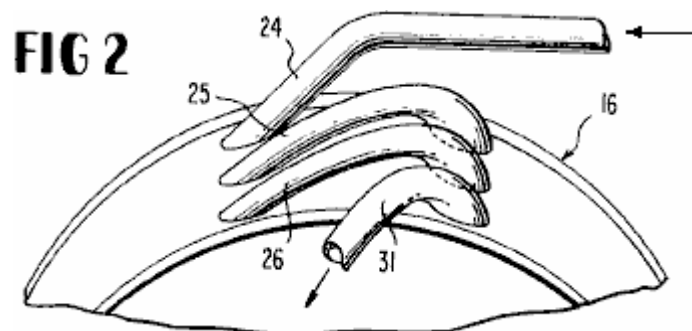

Fig.2 is a fragmentary perspective view of a rotary prime mover utilised in the system.

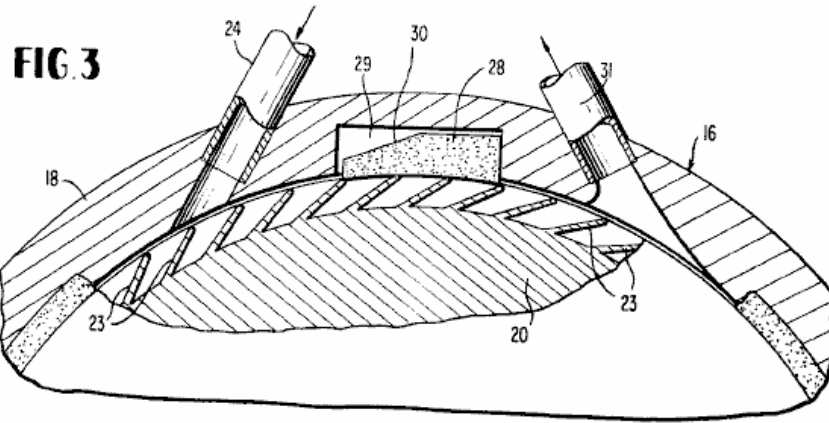

Fig.3 is an enlarged fragmentary vertical section through the prime mover taken at right angles to its rotational axis.

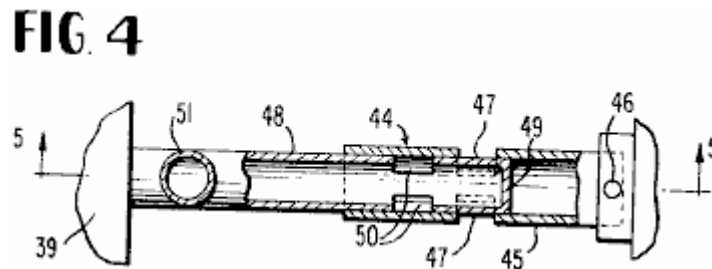

Fig.4 is an enlarged fragmentary vertical section taken on line 4--4 of Fig.1.

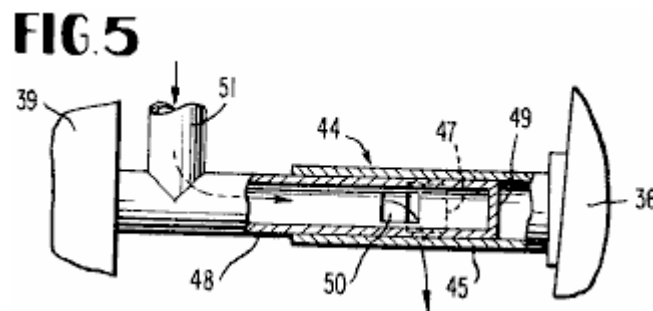
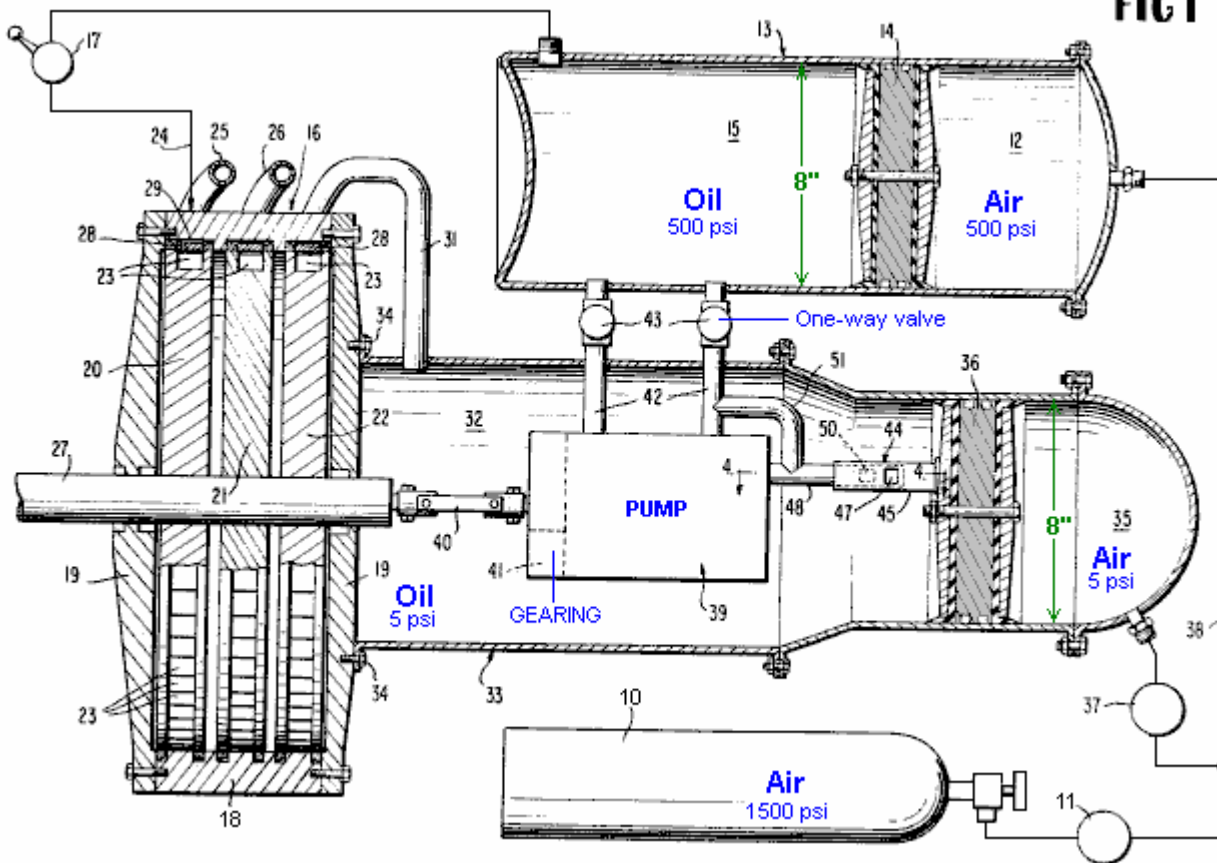

Fig.5 is a similar section taken on line 5--5 of Fig.4.

DETAILED DESCRIPTION

FIG 1



Referring to the drawings in detail, in which the same numbers refer to the same parts in each drawing, the numeral **10** designates a supply bottle or tank for a compressed elastic fluid, such as air. Preferably, the air in the bottle **10** is compressed to approximately 1,500 p.s.i. The compressed air from the bottle **10** is delivered through a suitable pressure regulating valve **11** to the chamber **12** of a high pressure tank **13** on one side of a free piston **14** in the bore of such tank. The free piston **14** separates the chamber **12** for compressed air from a second chamber **15** for an inelastic fluid, such as oil, on the opposite side of the free piston. The free piston **14** can move axially within the bore of the cylindrical tank **13** and is constantly self-adjusting there to maintain a proper volumetric balance between the two separated fluids of the system. The free piston has the ability to maintain the two fluids, air and oil, completely separated during the operation of the system.

The regulator valve **11** delivers compressed air to the chamber **12** under a pressure of approximately 500 p.s.i. The working inelastic fluid, oil, which fills the chamber **15** of high pressure tank **13** is maintained under 500 p.s.i. pressure by the expansive force of the elastic compressed air in the chamber **12** on the free piston **14**. The oil in the chamber **15** is delivered to a prime mover **16**, such as an oil turbine, through a suitable supply regulating or throttle valve **17** which controls the volume of pressurised oil delivered to the prime mover.

The turbine **16** embodies a stator consisting of a casing ring **18** and end cover plates **19** joined to it in a fluid-tight manner. It further embodies a single or plural stage impeller or rotor having bladed wheels **20**, **21** and **22** in the illustrated embodiment. The peripheral blades **23** of these turbine wheels receive the motive fluid from the pressurised chamber **15** through serially connected nozzles **24**, **25** and **26**, connected generally tangentially through the stator ring **18**, as shown in **Fig.3**. The first nozzle **24** shown schematically in **Fig.1** is connected directly with the outlet of the throttle valve **17**. The successive nozzles **25** and **26** deliver the pressurised working fluid serially to the blades **23** of the turbine wheels **21** and **22**, all of the turbine wheels being suitably coupled to a central axial output or working shaft **27** of the turbine **16**.

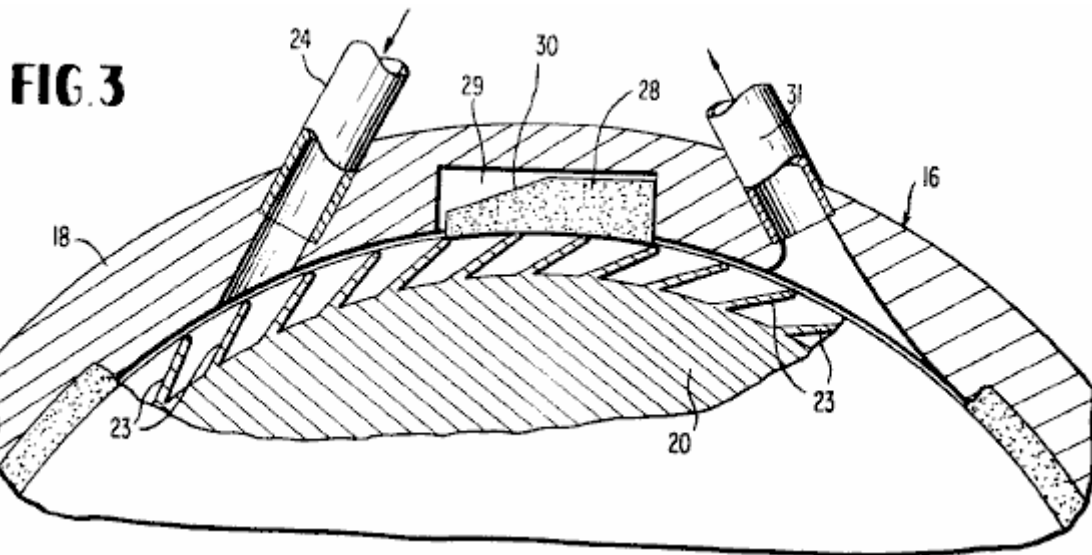

Back-pressure sealing blocks **28**, made of fibre, are contained within recesses **29** of casing ring **18** to prevent comingling of the working fluid and exhaust at each stage of the turbine. A back-pressure sealing block **28** is actually only required in the third stage between inlet **26** and exhaust **31**, because of the pressure distribution, but such a block can be included in each stage as shown in **Fig.1**. The top surface, including a sloping face portion **30** on each block **28**, reacts with the pressurised fluid to keep the fibre block sealed against the adjacent, bladed turbine wheel; and the longer the slope on the block to increase it's top surface area, the greater will be the sealing pressure pushing it against the periphery of the wheel.

Leading from the final stage of the turbine **16** is a low-pressure working fluid exhaust nozzle **31** which delivers the working fluid, oil, into an oil supply chamber or reservoir **32** of a low pressure tank **33** which may be bolted to the adjacent end cover plate **19** of the turbine, as indicated at **34**. The oil entering the reservoir chamber **32** from the exhaust stage of the turbine is at a pressure of about 3-5 p.s.i. In a second chamber **35** of the low pressure tank **33** separated from the chamber **32** by an automatically moving or self-adjusting free piston **36**, compressed air at a balancing pressure of from 3-5 p.s.i. is maintained by a second pressure regulating valve **37**. The pressure regulating valve **37** is connected with the compressed air supply line **38** which extends from the regulating valve **11** to the high pressure chamber **12** for compressed air.

Within the chamber **32** is a gear pump **39** or the like having its input shaft connected by a coupling **40** with the turbine shaft **27**. Suitable reduction gearing **41** for the pump may be provided internally, as shown, or in any other conventional manner, to gear down the rotational speed derived from the turbine shaft. The pump **39** is supplied with the oil in the filled chamber **32** delivered by the exhaust nozzle or conduit **31** from the turbine. The pump, as illustrated, has twin outlet or delivery conduits **42** each having a back-pressure check valve **43** connected therein and each delivering a like volume of pressurised oil back to the high pressure chamber **15** at a pressure of about 500 p.s.i. The pump **39** also has twin fluid inlets. The pump employed is preferably of the type known on the market as "Hydreco Tandem Gear Pump," Model No. 151515, L12BL, or equivalent. In some models, other types of pumps could be employed including pumps having a single inlet and outlet. The illustrated pump will operate clockwise or counter-clockwise and will deliver 14.1 g.p.m. at 1,800 r.p.m. and 1,500 p.s.i. Therefore, in the present application of the pump **39**, it will be operating at considerably less than capacity and will be under no undue stress.

FIG. 4

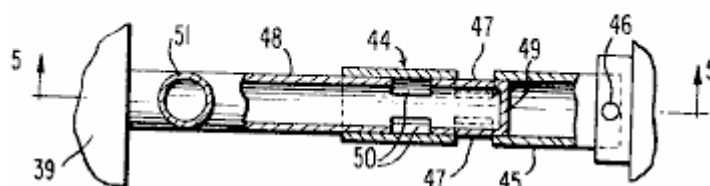
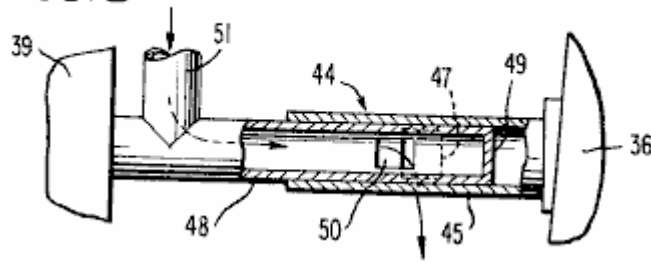

FIG.5

Since the pump depends for its supply of fluid on the delivery of oil at low pressure from the turbine **16** into the chamber **32**, an automatically operating by-pass sleeve valve device **44** for oil is provided as indicated in **Fig.1**, **Fig.4** and **Fig.5**. This device comprises an exterior sleeve or tube **45** having one end directly rigidly secured as at **46** to the movable free piston **36**. This sleeve **45** is provided with slots **47** intermediate its ends. A co-acting interior sleeve **48** engages telescopically and slidably within the sleeve **45** and has a closed end wall **49** and ports or slots **50** intermediate its ends, as shown. The sleeve **48** communicates with one of the delivery conduits **42** by way of an elbow **51**, and the sleeve **48** is also connected with the adjacent end of the pump **39**, as shown.

As long as the chamber **32** is filled with low pressure oil sufficient to balance the low air pressure in the chamber **35** on the opposite side of free piston **36**, such piston will be positioned as shown in **Fig.1** and **Fig.4** so that the slots **47** and **50** of the two sleeves **45** and **48** are out of registration and therefore no flow path exists through them. Under such circumstances, the oil from the chamber **32** will enter the pump and will be delivered by the two conduits **42** at the required pressure to the chamber **15**. Should the supply of oil from the turbine **16** to the chamber **32** diminish so that pump **39** might not be adequately supplied, then the resulting drop in pressure in the chamber **32** will cause the free piston **36** to move to the left in **Fig.1** and bring the slots **47** into registration or partial registration with the slots **50**, as depicted in **Fig.5**. This will instantly establish a by-pass for oil from one conduit **42** back through the elbow **51** and tubes **48** and **45** and their registering slots to the oil chamber **32** to maintain this chamber filled and properly pressurised at all times. The by-pass arrangement is completely automatic and responds to a diminished supply of oil from the turbine into the chamber **32**, so long as the required compressed air pressure of 3-5 p.s.i. is maintained in the chamber **35**.

Briefly, in summary, the system operates as follows. The pressurised inelastic and non-compressible fluid, oil, from the chamber **15** is throttled into the turbine **16** by utilising the throttle valve **17** in a control station. The resulting rotation of the shaft **27** produces the required mechanical energy or work to power a given instrumentality, such as a propeller. A relatively small component of this work energy is utilised through the coupling **40** to drive the pump **39** which maintains the necessary volumetric flow of oil from the turbine back into the high pressure chamber **15**, with the automatic by-pass **44** coming into operation whenever needed.

The ultimate source of energy for the closed power system is the compressed elastic fluid, air, in the tank or bottle **10** which through the regulating valves **11** and **37** maintains a constant air pressure in the required degree in each of the chambers **12** and **35**. As described, the air pressure in the high pressure chamber **12** will be approximately 500 p.s.i. and in the low pressure chamber **35** will be approximately 3-5 p.s.i.

It may be observed in **Fig.1** that the tank **33** is enlarged relative to the tank **13** to compensate for the space occupied by the pump and associated components. The usable volumes of the two tanks are approximately equal.

In an operative embodiment of the invention, the two free pistons **14** and **36** and the tank bores receiving them are 8 inches in diameter. The approximate diameters of the bladed turbine wheels are 18 inches. The pump **39** is approximately 10 inches long and 5 inches in diameter. The tank **13** is about 21 inches long between its crowned end walls. The tank **33** is 10 inches in diameter adjacent to the pump **39**.

The terms and expressions which have been employed herein are used as terms of description and not of limitation, and there is no intention, in the use of such terms and expressions, of excluding any equivalents of the features shown and described or portions thereof but it is recognised that various modifications are possible within the scope of the invention claimed.

Josef Papp's Inert Gas Engine

US Patent 4,428,193

31st January 1984

Inventor: Josef Papp

INERT GAS FUEL, FUEL PREPARATION APPARATUS AND SYSTEM FOR EXTRACTING USEFUL WORK FROM THE FUEL

ABSTRACT

An inert gas fuel consisting essentially of a precise, homogeneous mixture of helium, neon, argon, krypton and xenon. Apparatus for preparing the fuel includes a mixing chamber, tubing to allow movement of each inert gas into and through the various stages of the apparatus, a plurality of electric coils for producing magnetic fields, an ion gauge, ionises, cathode ray tubes, filters, a polarise and a high frequency generator. An engine for extracting useful work from the fuel has at least two closed cylinders for fuel, each cylinder being defined by a head and a piston. A plurality of electrodes extend into each chamber, some containing low level radioactive material. The head has a generally concave depression facing a generally semi-toroidal depression in the surface of the piston. The piston is axially movable with respect to the head from a first position to a second position and back, which linear motion is converted to rotary motion by a crankshaft. The engine's electrical system includes coils and condensers which circle each cylinder, an electric generator, and circuitry for controlling the flow of current within the system.

BACKGROUND OF THE INVENTION

This invention relates to closed reciprocating engines, i.e., ones which do not require an air supply and do not emit exhaust gases, and more particularly to such engines which use inert gases as fuel. It also concerns such inert gas fuels and apparatus for preparing same.

Currently available internal combustion engines suffer from several disadvantages. They are inefficient in their utilisation of the energy present in their fuels. The fuel itself is generally a petroleum derivative with an ever-increasing price and sometimes limited availability. The burning of such fuel normally results in pollutants which are emitted into the atmosphere. These engines require oxygen and, therefore, are particularly unsuitable in environments, such as underwater or outer space, in which gaseous oxygen is relatively unavailable. Present internal combustion engines are, furthermore, relatively complex with a great number of moving parts. Larger units, such as fossil-fuel electric power plants, escape some of the disadvantages of the present internal combustion engine, but not, inter alia, those of pollution, price of fuel and availability of fuel.

Several alternative energy sources have been proposed, such as the sun (through direct solar power devices), nuclear fission and nuclear fusion. Due to the lack of public acceptance, cost, other pollutants, technical problems, and/or lack of development, these sources have not wholly solved the problem. Moreover, the preparation of fuel for nuclear fission and nuclear fusion reactors has heretofore been a complicated process requiring expensive apparatus.

SUMMARY OF THE INVENTION

Among the several objects of the present invention may be noted the provision of an engine which is efficient; the provision of an engine which does not require frequent refuelling; the provision of an engine which develops no pollutants in operation; the provision of an engine which is particularly suited for use in environments devoid of free oxygen; the provision of an engine which requires no oxygen in operation; the provision of an engine having a relatively small number of moving parts; the provision of an engine of a relatively simple construction; the provision of an engine which can be used in light and heavy-duty applications; the provision of an engine which is relatively inexpensive to make and operate; the provision of a fuel which uses widely available components; the provision of a fuel which is relatively inexpensive; the provision of a fuel which is not a petroleum derivative; the provision of relatively simple and inexpensive apparatus for preparing inert gases for use as a fuel; the provision of such apparatus which mixes inert gases in precise, predetermined ratios; and the provision of such apparatus which eliminates contaminants from the inert gas mixture. Other objects and features will be in part apparent and in part pointed out hereinafter.

Briefly, in one aspect the engine of the present invention includes a head having a generally concave depression in it, the head defining one end of a chamber, a piston having a generally semi-toroidal depression in its upper surface, the piston defining the other end of the chamber, and a plurality of electrodes extending into the chamber for exciting and igniting the working fluid. The piston can move along its axis towards and away from the head, causing the volume of the chamber to alter, depending on the position of the piston relative to the head.

In another aspect, the engine of the present invention includes a head which defines one end of the chamber, a piston which defines the other end of the chamber, a plurality of magnetic coils wound around the chamber for generating magnetic fields inside the chamber, and at least four electrodes extending into the chamber for exciting and igniting the working fluid. The magnetic coils are generally coaxial with the chamber. The electrodes are generally equidistantly spaced from the axis of the chamber and are each normally positioned 90 degrees from the adjacent electrodes. Lines between opposed pairs of electrodes intersect generally on the axis of the chamber to define a focal point.

In a further aspect, the engine of the present invention includes a head which defines one end of a chamber, a piston which defines the other end of the chamber, at least two electric coils wound around the chamber for generating magnetic fields inside the chamber, and a plurality of electrodes extending into the chamber for exciting and igniting the working fluid. The electric coils are generally coaxial with the chamber. And the working fluid includes a mixture of inert gases.

The apparatus of the present invention for preparing a mixture of inert gases for use as a fuel includes a chamber, electric coils for generating predetermined magnetic fields inside the chamber, tubing adapted to be connected to sources of preselected inert gases for flow of the gases from the sources to the chamber, and ionisers for ionising the gases.

The fuel of the present invention includes a mixture of inert gases including approximately 36% helium, approximately 26% neon, approximately 17% argon, approximately 13% krypton, and approximately 8% xenon by volume.

BRIEF DESCRIPTION OF THE DRAWINGS

Fig.1 is a side elevation of an engine of this invention:

Fig.2 is a rear elevation of an engine of this invention:

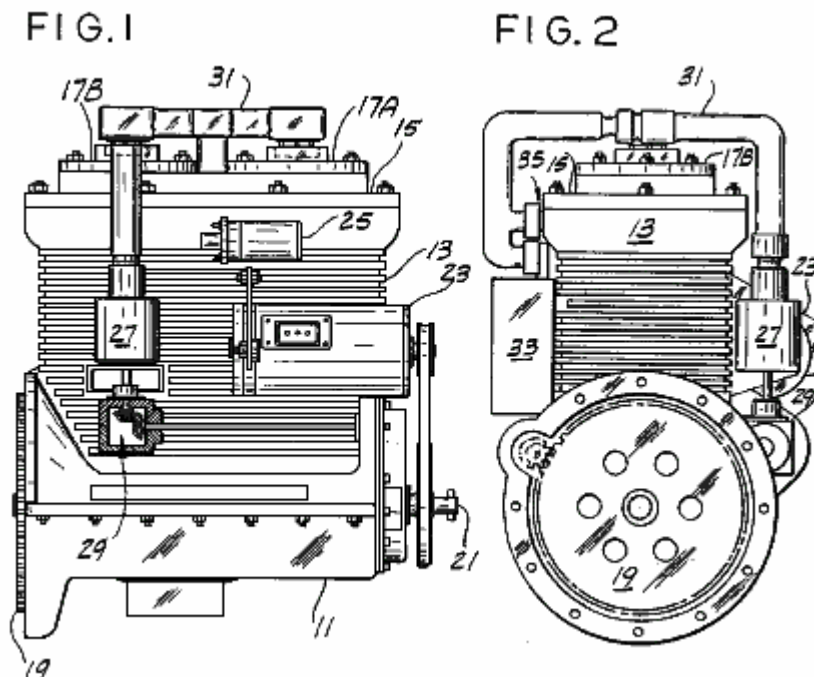

Fig.3 is a top view of an engine of this invention:

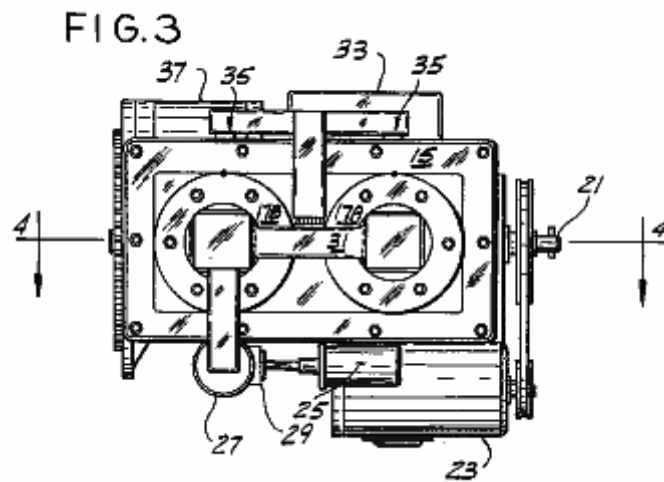

Fig.4 is a cross-sectional view generally along line 4--4 of Fig.3 of an engine of this invention:

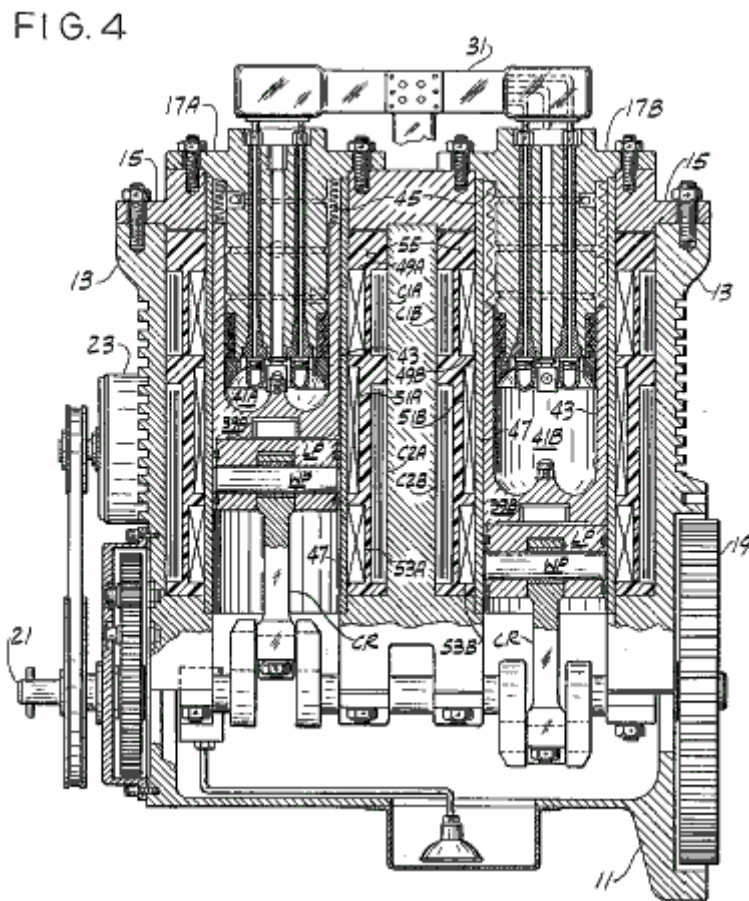

Fig.5 is a cross-sectional view of a cylinder of an engine of this invention:

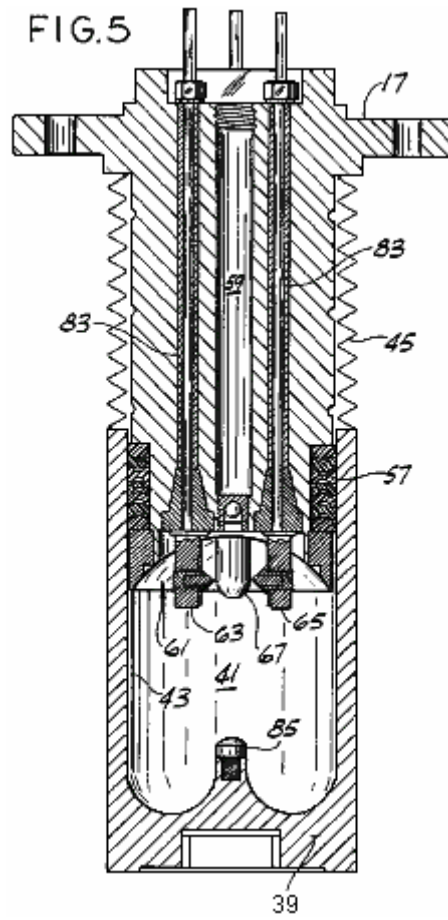

Fig.6 is a plan of the base of a cylinder head of an engine of this invention:

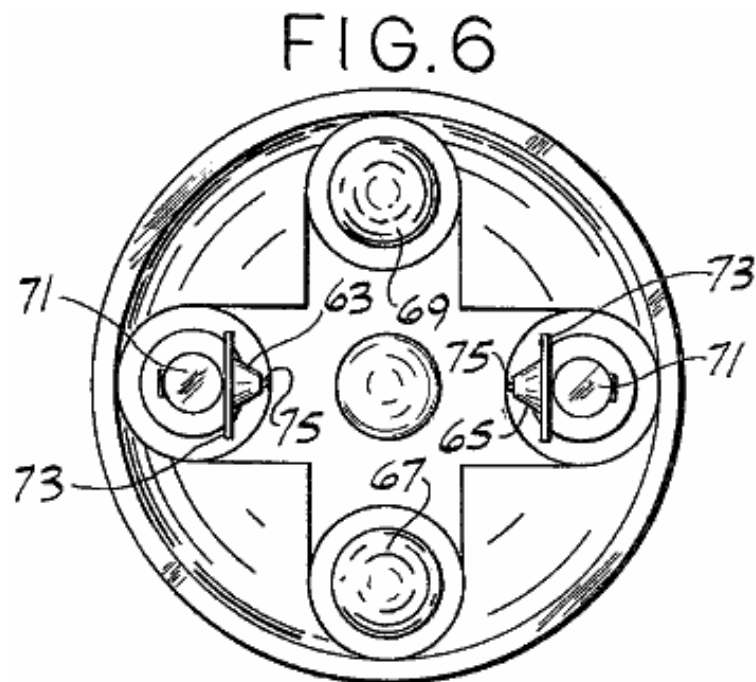

Fig.7 is an elevation of an electrode rod of an engine of this invention:

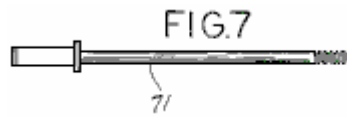

Fig.8 is an elevation, with parts broken away, of one type of electrode used in an engine of this invention:

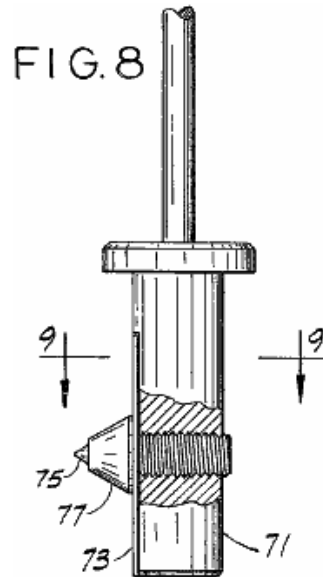

Fig.9 is a view taken generally along line 9--9 of **Fig.8**:

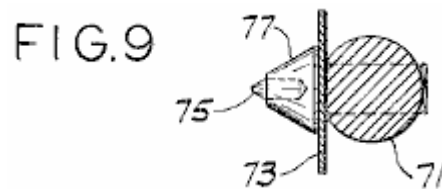

Fig.10 is a cross-sectional view of a second type of electrode used in an engine of this invention:

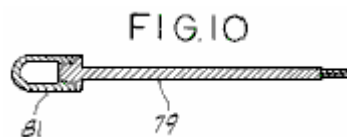

Fig.11 is a cross-sectional view similar to **Fig.5** showing the piston in its uppermost position:

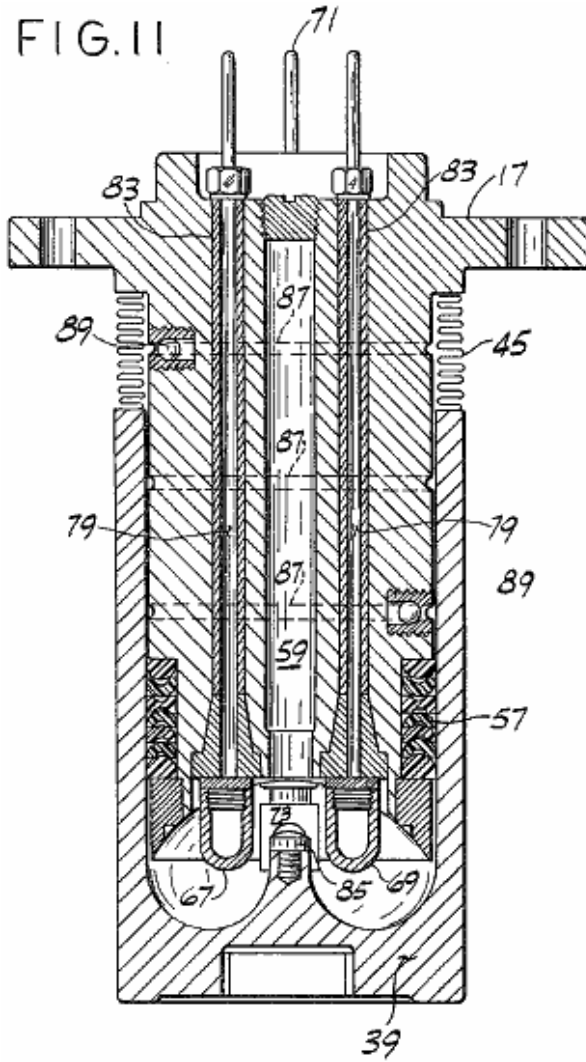

Fig.12 is a cross-sectional view similar to Fig.5 showing an alternative cylinder used in an engine of this invention:

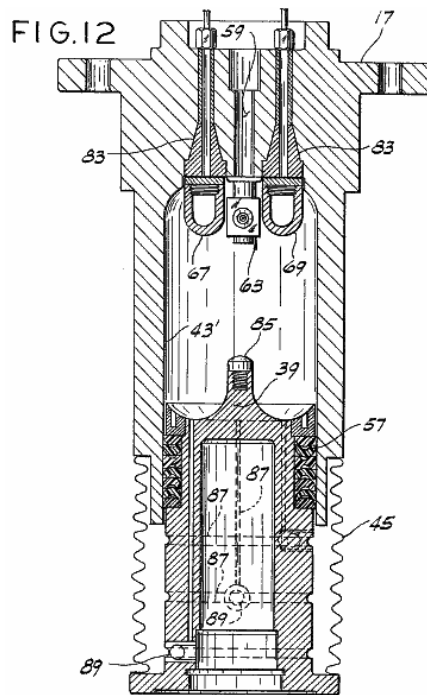

Fig.12A is a cross-sectional view similar to Fig.5 and Fig.12, but on a reduced scale and with parts broken away, showing an additional embodiment of a cylinder head used in an engine of this invention:

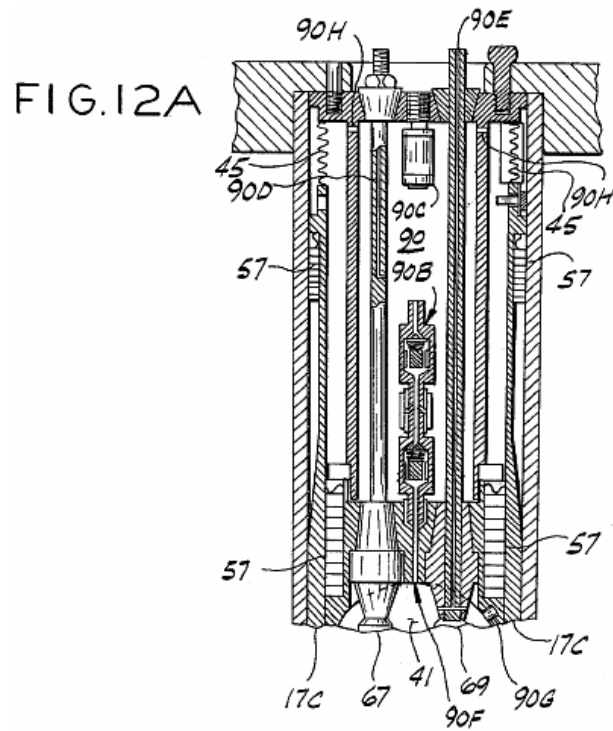

Fig.13A and Fig.13B are schematic diagrams of the electrical circuitry for an engine of this invention:

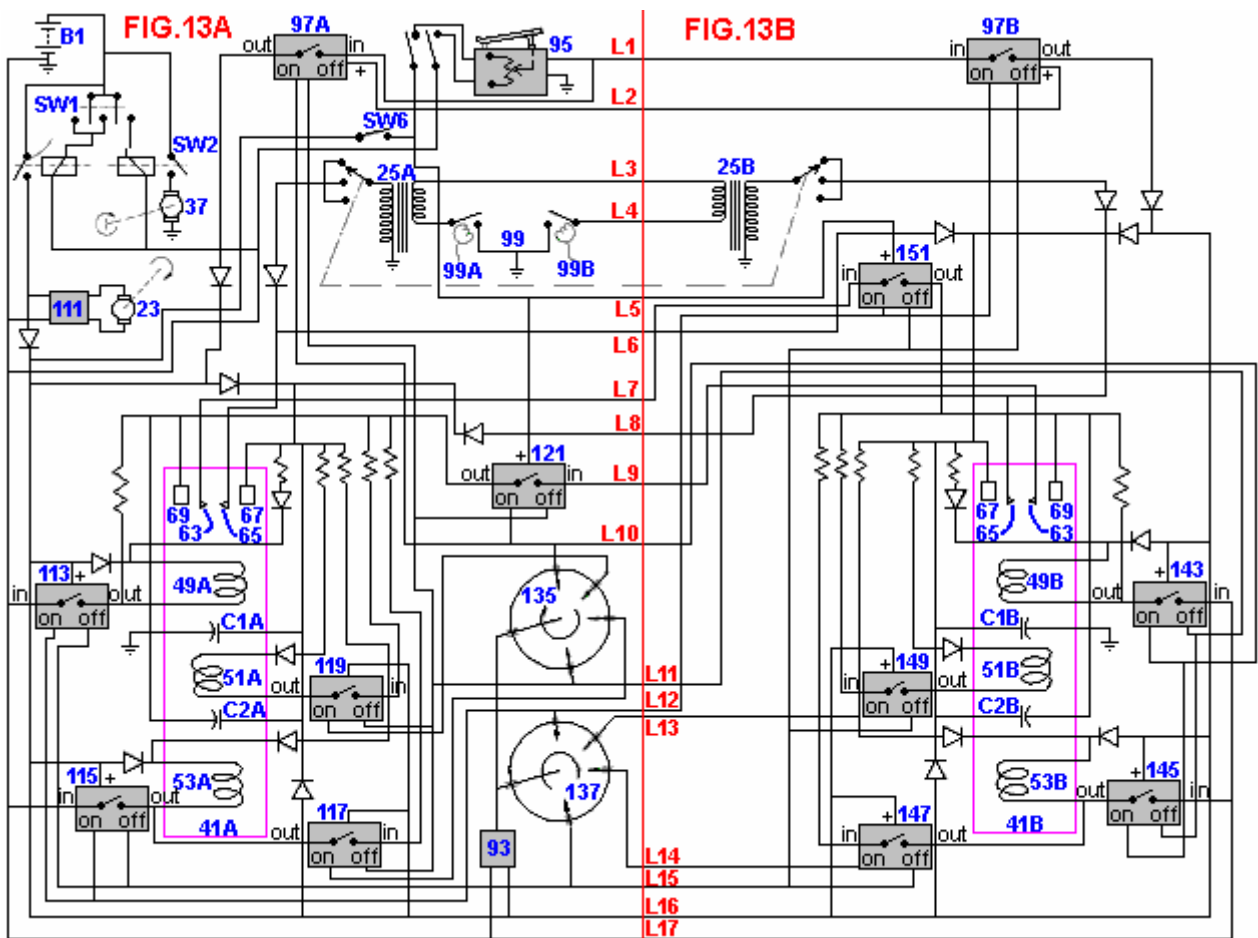

Fig.14 is a schematic diagram of an alternative high-voltage ignition system for an engine of this invention:

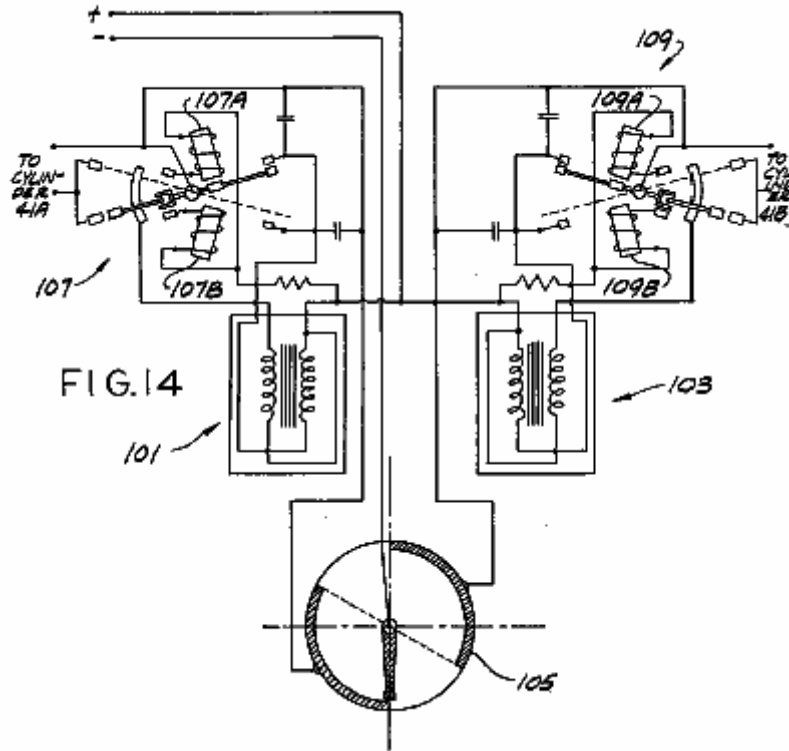

Fig.15 is a schematic diagram of an electronic switching unit for an engine of this invention:

Fig.16 is a schematic diagram of a regulator/electronic switching unit for an engine of this invention:

FIG.15

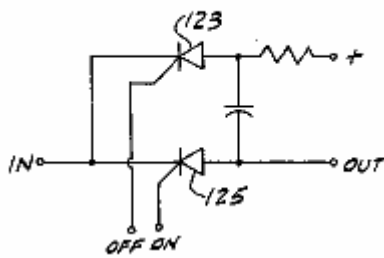
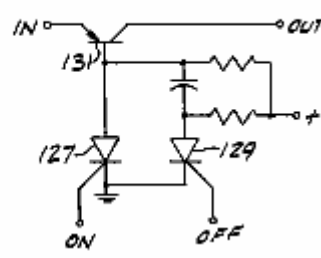
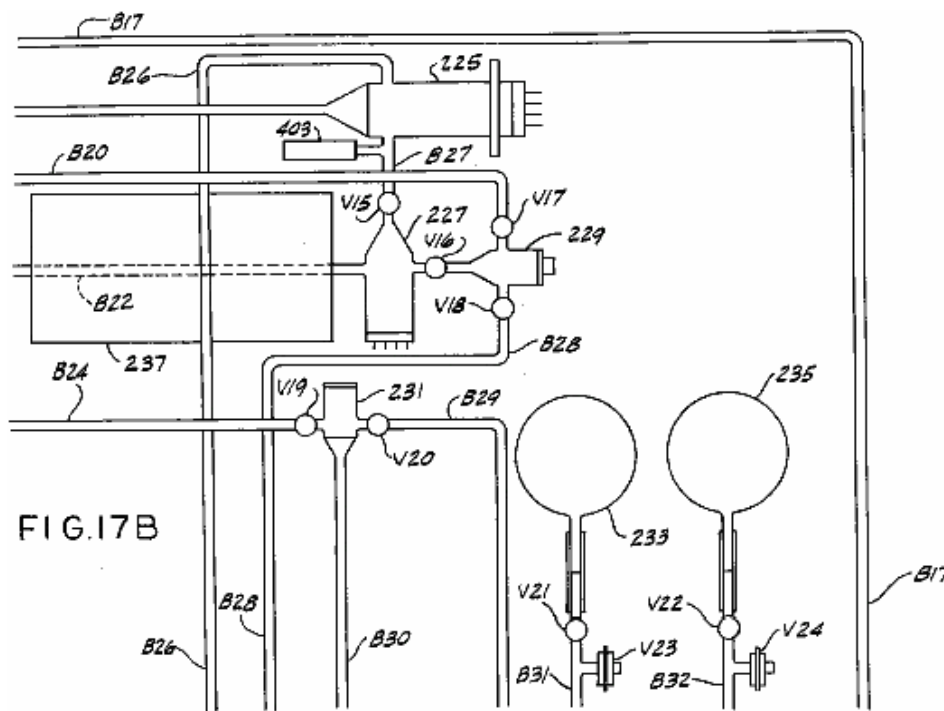
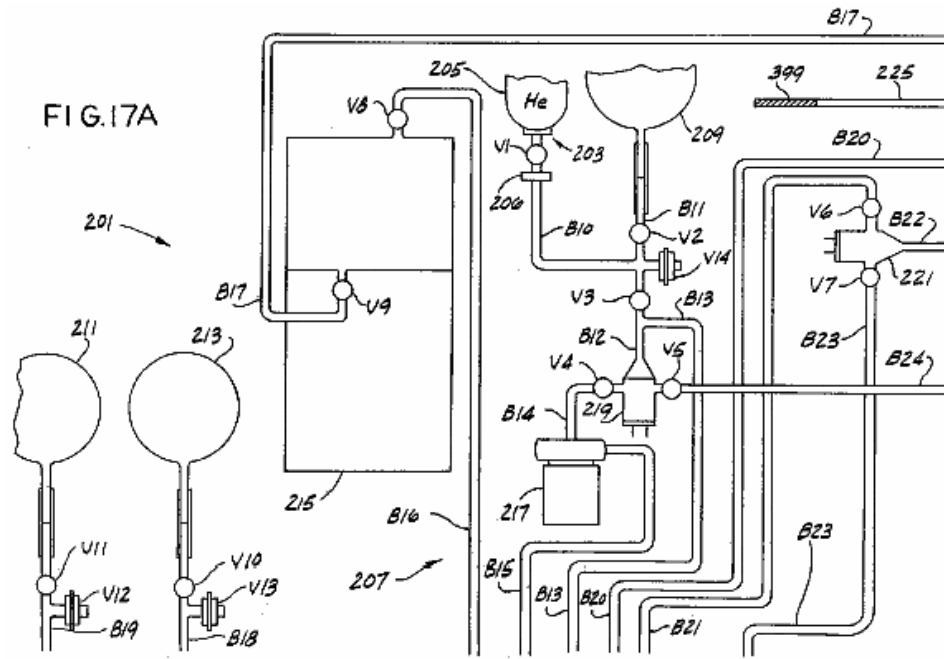

FIG.16



Figs.17A-17D are schematic diagrams of a fuel mixer of the present invention:



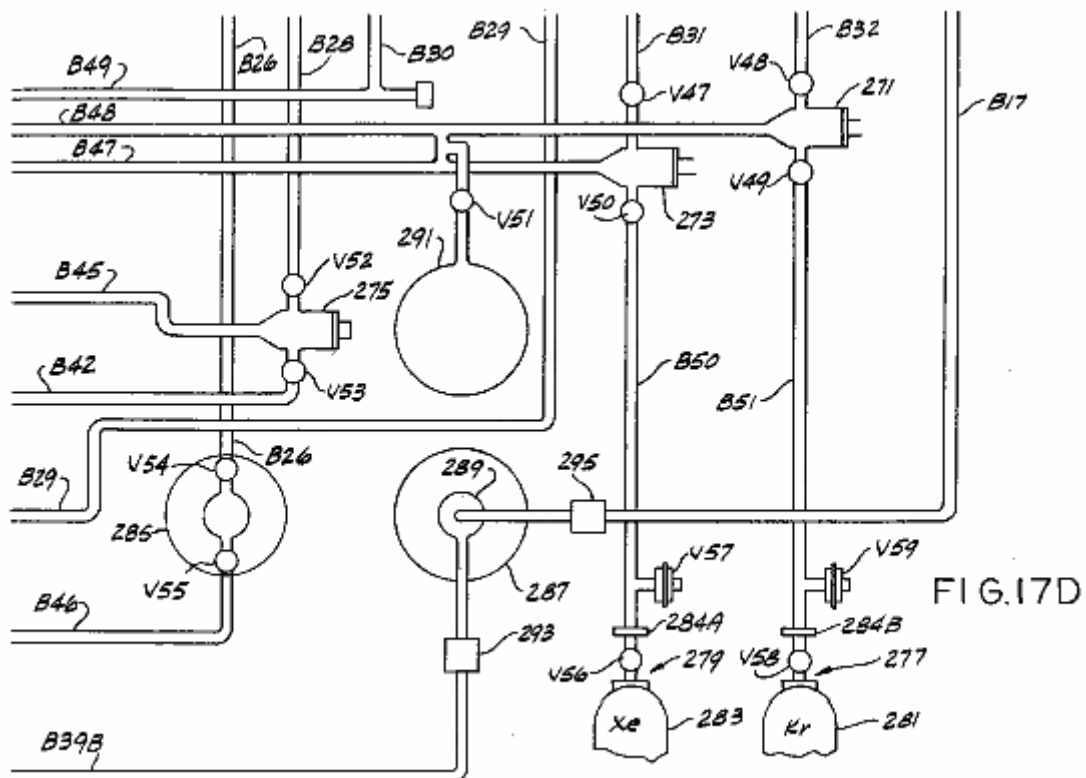
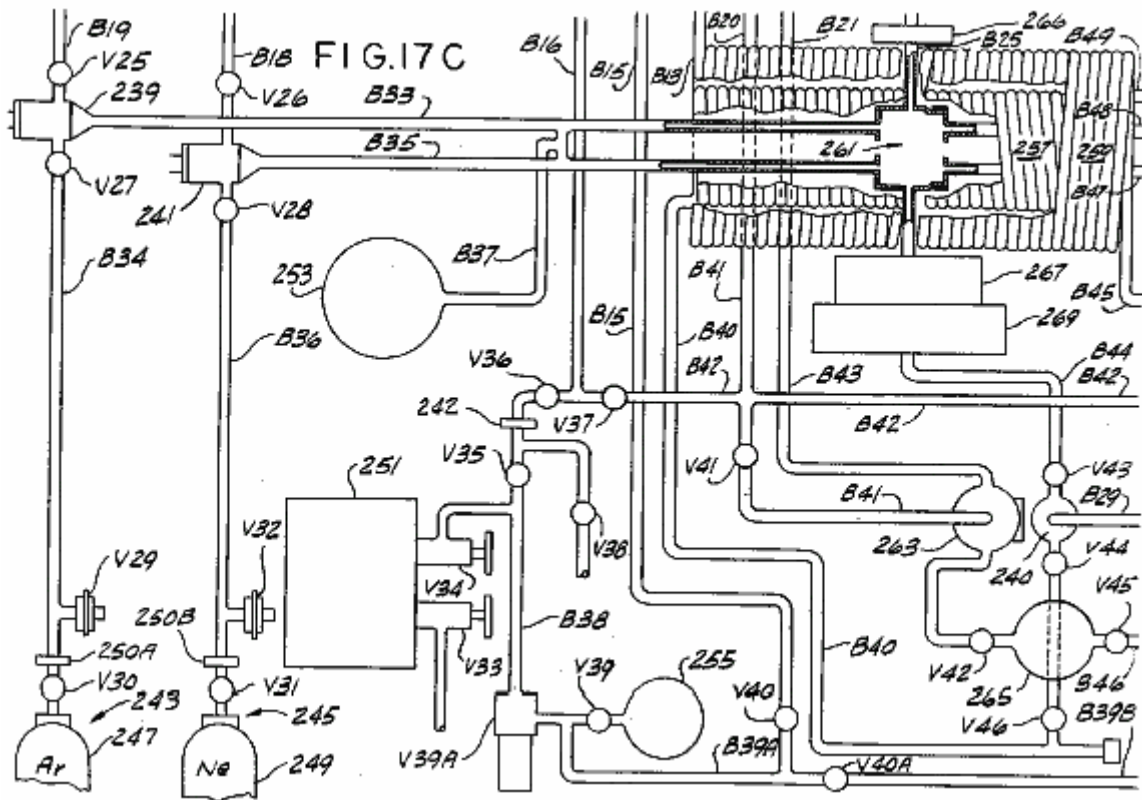
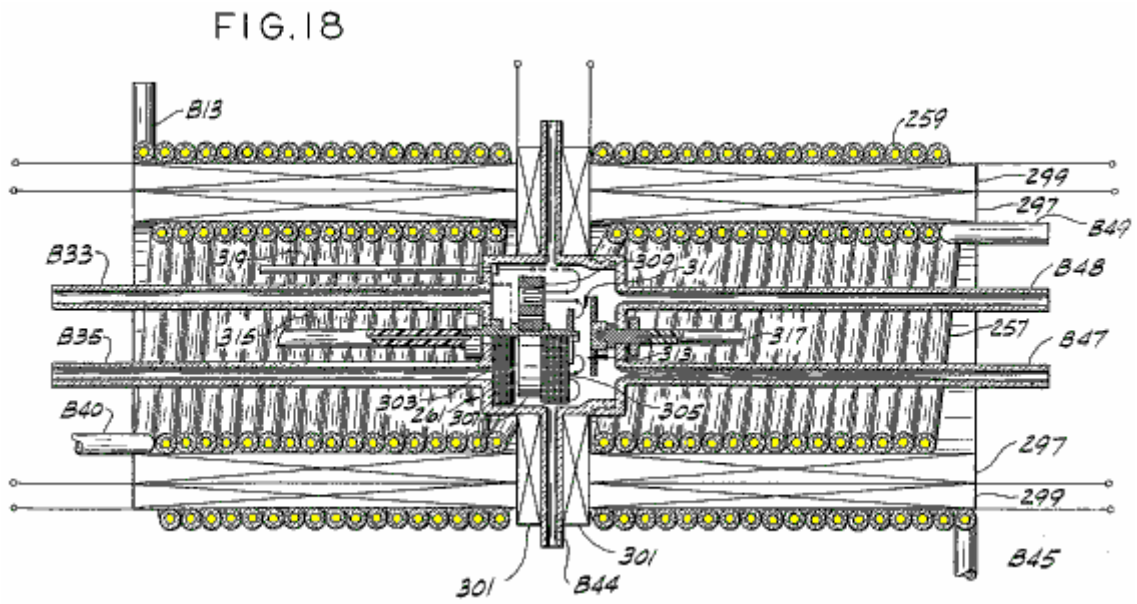
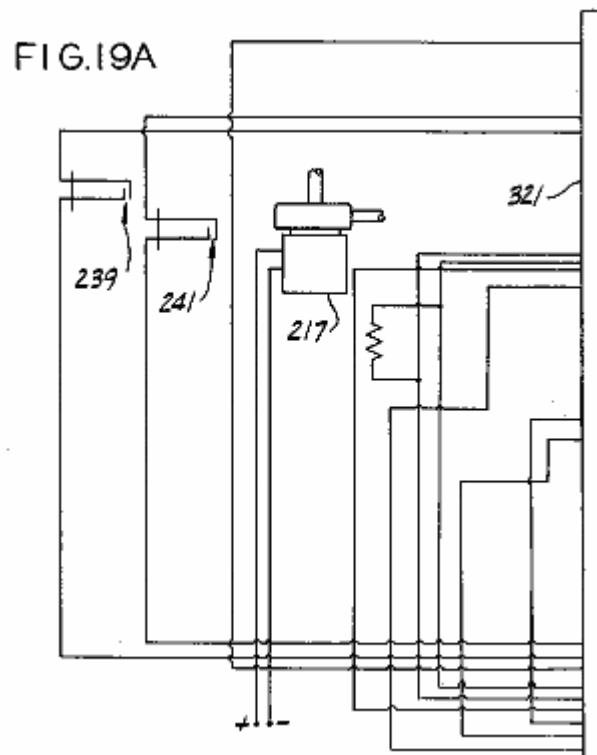

Fig.18 is a schematic diagram of the mixing chamber portion of the fuel mixer shown in Figs.17A-17D:



Figs.19A-19E are schematic diagrams of a portion of the electrical circuitry of the fuel mixer shown in Figs.17A-17D:



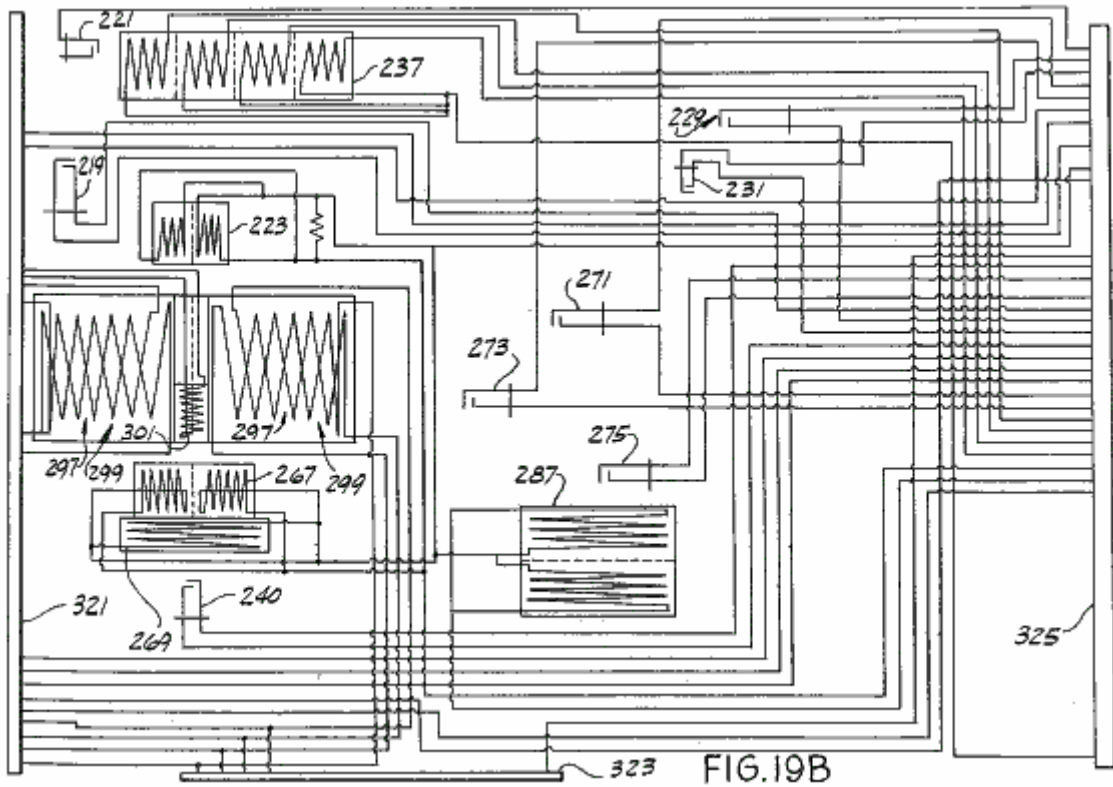

FIG. 19B

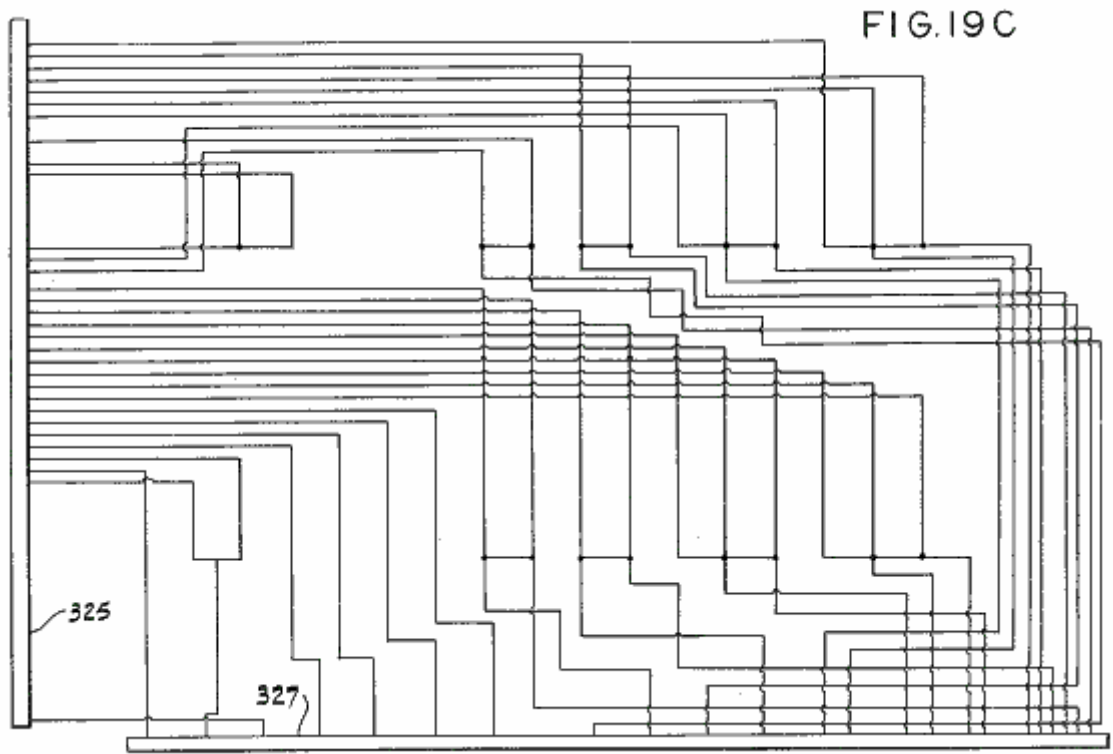

FIG. 19C

Figs.20A-20F are schematic diagrams of the rest of the electrical circuitry of the fuel mixer shown in Figs.17A-17D:

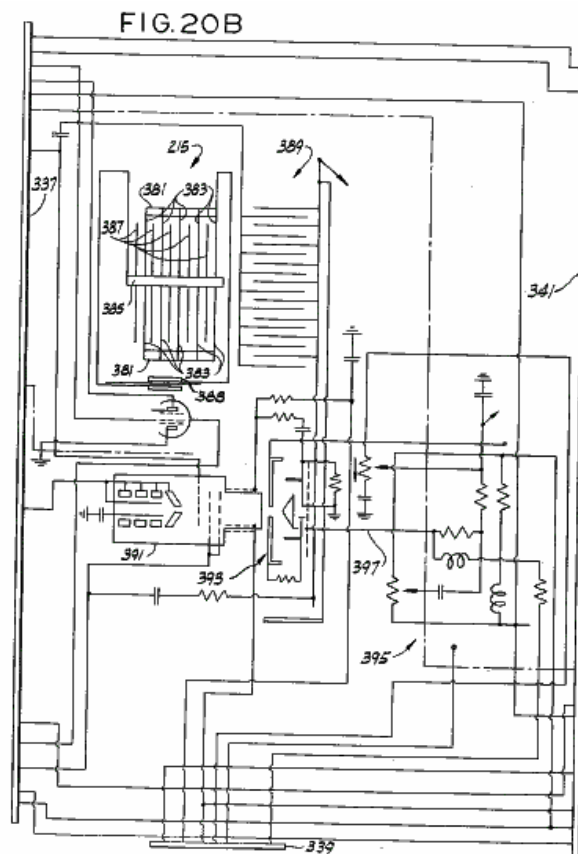
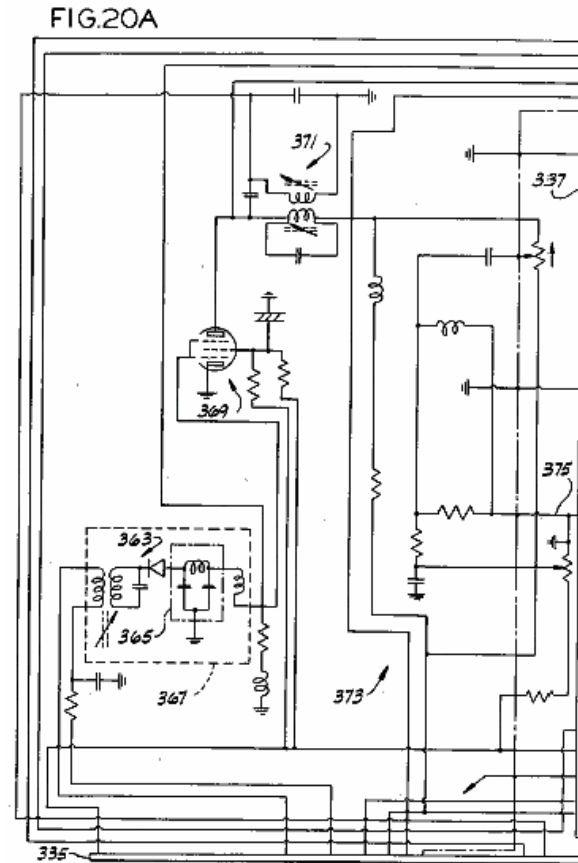
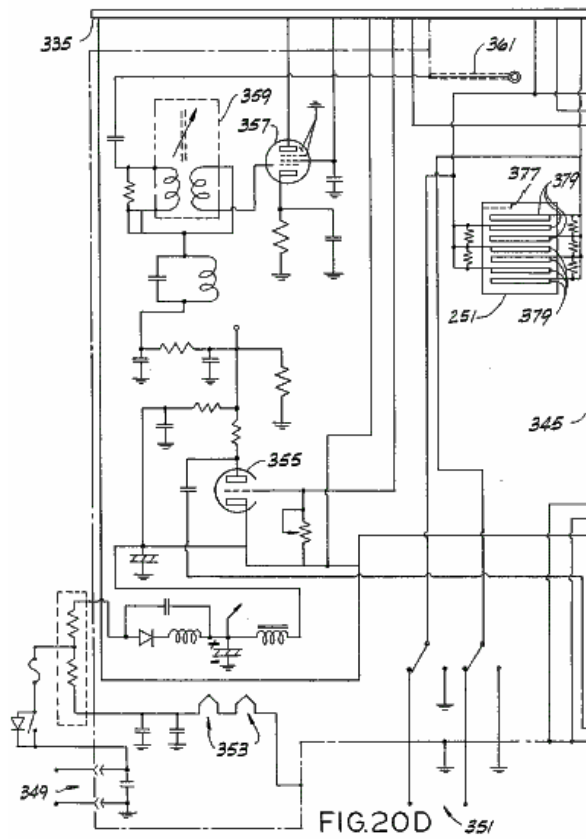
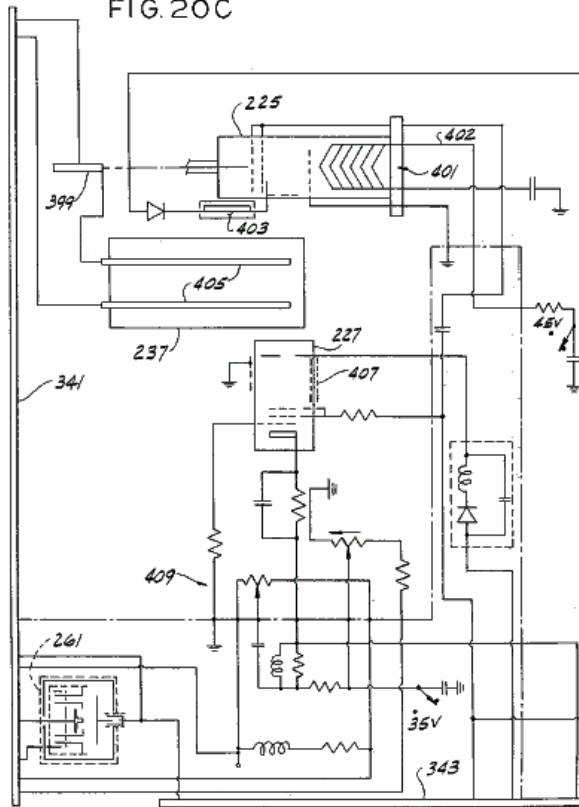

FIG. 20C



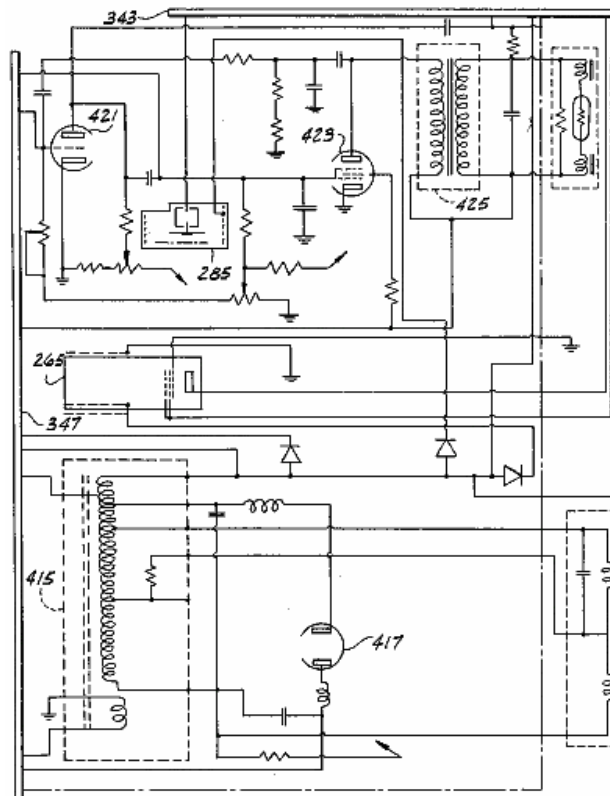
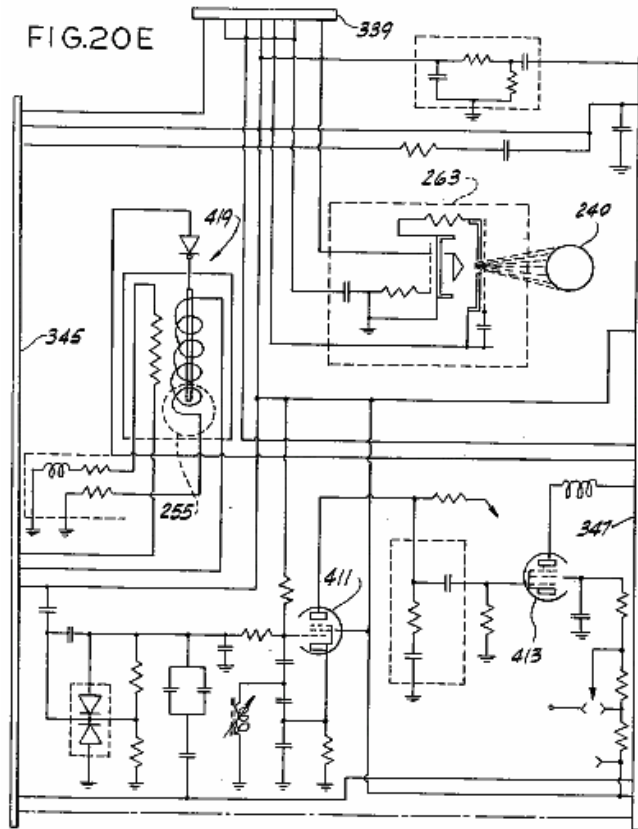
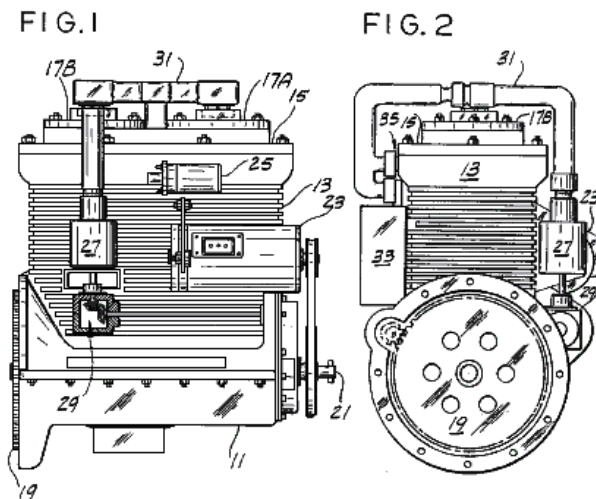

FIG. 20F

Note: Corresponding reference characters indicate corresponding parts throughout all of the views of the drawings.

DESCRIPTION OF A PREFERRED EMBODIMENT



Referring to the drawings, there is shown in **Fig.1** a two-cylinder engine **11** comprising a block **13** preferably of a nonmagnetic material such as aluminium, a nonmagnetic head **15**, and a pair of cylinder heads **17A** and **17B** of a magnetisable material such as 0.1-0.3% carbon steel. Also shown in **Fig.1** is a flywheel **19** attached to a crankshaft **21**, a generator **23**, a high-voltage coil **25**, a distributor **27** attached by a gear arrangement shown in part at **29** to the crankshaft, and an electrical cable **31** which is connected to the distributor and to both cylinders. Cable **31** (see **Fig.2**) is also electrically connected to a switching unit **33** which preferably comprises a plurality of silicon controlled rectifiers (SCRs) or transistors. Also shown in **Fig.2** is a second electrical connection of the cable to the cylinders, which connection is indicated generally at **35**. Turning to **Fig.3**, there is shown a starter motor **37** as well as a clearer view of the connections **35** to each cylinder.

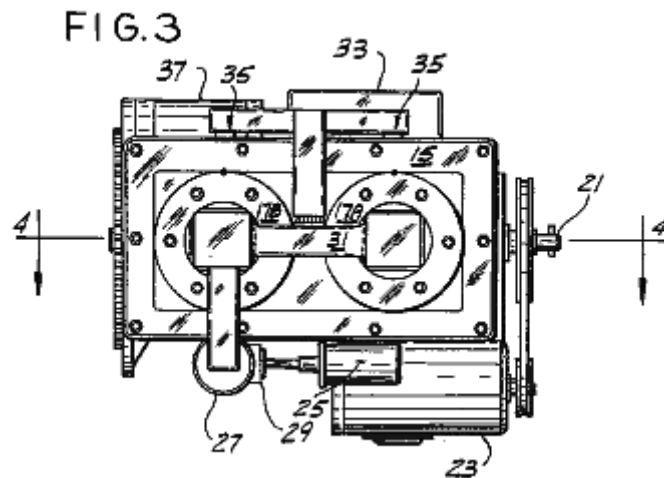

A cross section of the engine is shown in **Fig.4**. The cylinder heads have associated with them, pistons marked **39A** and **39B**, respectively, the heads and pistons define opposite ends of a pair of chambers or cylinders **41A** and **41B** respectively. The pistons are made of a magnetisable material. Although only two chambers are shown, the engine can include any number. It is preferred, however, for reasons set forth below, that there be an even number of cylinders. Pistons **39A** and **39B** move axially with respect to their corresponding heads from a first position (the position of piston **39A** in **Fig.4**) to a second position (the position of piston **39B**) and back, each piston being suitably connected to crankshaft **21**. As shown in **Fig.4**, this suitable connection can include a connecting rod **CR**, a wrist pin **WP**, and a lower piston portion or power piston **LP**. The connecting rods and/or power pistons must be of non-magnetisable material. When a split piston is used, pistons **39A** and **39B** are suitably connected to lower piston portions **LP** by bolting, spring-loaded press fitting, or the like. Pistons **39A** and **39B** are attached 180 degrees apart from each other with respect to the crankshaft so that when one piston is at top dead centre (TDC) the other will be at bottom dead centre (BDC) and vice versa. Additional pairs of cylinders may be added as desired but the pistons of each pair should be attached to the crankshaft 180 degrees from each other. Of course, the relative position of each piston with respect to its respective head determines the volume of its chamber.

FIG. 4

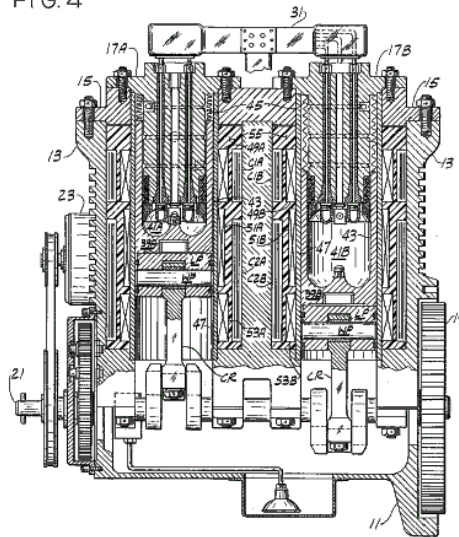

Integral with the piston bodies are walls **43** which form the walls of the chambers. Preferably, a set of air-tight bellows **45**, of similar construction to that sold under the designation ME 197-0009-001 by the Belfab Company of Daytona Beach, Fla., are suitably secured between walls **43** and cylinder heads **17A** and **17B** respectively to form an airtight seal between each piston and its cylinder head. While walls **43** and piston **39** can be made of one magnetisable piece, a preferable and more efficient construction has walls **43** separate from piston **39** and made of a non-magnetisable material. The length of time that a given engine will run is a function of the efficacy of its sealing system. Means, such as bellows **45**, for hermetically sealing the cylinders will optimise said length of time. Such a hermetic seal should be secured between walls **43** and cylinder heads **17** to form an airtight seal between them. This seal could be the airtight bellows system shown or some other sealing system such as an oil sealing system.

Cylinder bodies **47** (see **Fig.4**), made of nonmagnetic material such as stainless steel, extend from the point of attachment of each bellows to its cylinder head to the base of the corresponding pistons, forming sleeves for each piston in which each piston moves. Three sets of electric coils **49A**, **49B**, **51A**, **51B**, and **53A**, **53B**, are wound around sleeves **47**, and hence around chambers **41A** and **41B**, respectively, for generating magnetic fields in the chambers, those coils being generally coaxial with their respective chambers. Each of these coils has an inductance of approximately 100 mH. It is preferred that 14-19 gauge wire be used to wind these coils and that the coils be coated with a suitable coating, such as #9615 hardener from Furane Plastics, Inc., of Los Angeles, California, or the coating sold by the Epoxylite Corp. of South El Monte, California under the trade designation Epoxylite 8683. Each chamber is also surrounded by a pair of capacitors, **C1A**, **C1B** and **C2A**, **C2B** wound around it, capacitors **C1A**, **C1B** having a capacitance of approximately 1.3 microfarads and capacitors **C2A**, **C2B** having a capacitance of approximately 2.2 microfarads. The coils and capacitors are potted in hardened epoxy of fibreglass material **55**. The epoxy resin and hardener sold under the designations EPI Bond 121 and #9615 hardener by Furane Plastics, supra, are satisfactory, but other epoxy material which will remain stable at temperatures up to 200 degrees F would probably also be acceptable. It is preferred that a small amount of graphite such as that sold under the trade designation Asbury 225 by Asbury Graphite, Inc. of Rodeo, Calif., be included in the epoxy potting to prevent nuclear particles formed in the chamber from escaping from the apparatus. Ten to 15% graphite to epoxy by weight is more than enough.

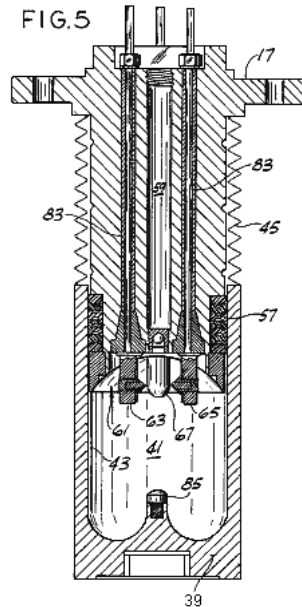

A typical cylinder is shown in section in **Fig.5**, showing the piston in its fully extended position with respect to the head and showing many details on a somewhat larger scale than that of **Fig.4**. A set of seals **57**, made of a material such as that sold under the trade designation Teflon by the DuPont Company of Delaware, is positioned between the cylinder head and wall **43** to prevent escape of the working fluid from chamber **41**. A filler tube **59** with a ball valve at its lower end is used in filling the chamber with the working fluid but is closed during operation of the engine.

The cylinder head has a generally concave depression therein, indicated at **61**, which defines the top end of the chamber. A plurality of electrodes for exciting and igniting the working fluid extend through the cylinder head into the chamber. Two of those electrodes, shown in section in **Fig.5** and labelled **63** and **65**, have tungsten points **75**, while the other two, labelled **67** and **69** (see **Fig.6** for electrode **69**) are containers called, respectively, the anode and the cathode. The electrodes are generally equidistantly spaced from the axes of their chambers and are generally coplanar to each other, their mutual plane being perpendicular to the axes of their chambers. Each electrode is positioned 90 degrees from adjacent electrodes in this embodiment and are generally positioned so that a line from the anode to the cathode and a line between the other two electrodes intersect at a focal point generally on the axis of the chamber. The radial distance of each electrode from the focal point is fixed for a reason discussed below. The general construction of electrodes **63** and **65** is shown in **Fig.6** to **Fig.9**. These electrodes include a conductive rod **71** (see **Fig.7**) preferably of brass or copper; a conductive, generally rectangular plate **73** (see **Fig.6**, **Fig.8** and **Fig.9**); and tungsten point **75** mounted in a conductive base **77** generally at right angles to the plate (see **Fig.8** and **Fig.9**).

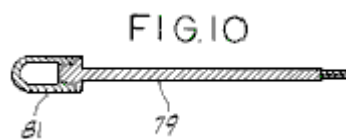

The construction of the anode and cathode is shown in **Fig.10**. Each includes a conductive rod **79** and a container **81**. The cathode container is substantially pure aluminium. If desired, aluminium alloys with, e.g., less than 5% copper, 1% manganese and 2% magnesium may be used. In one embodiment, the cathode container contains approximately four grams of thorium-232 and is filled with argon. In this same embodiment the anode container is copper or brass and contains approximately two grams of rubidium-37 and approximately three grams of phosphorus-15 hermetically sealed in mineral oil. In a second embodiment, the cathode is still aluminium, but it contains at least two grams of rubidium-37 in addition to the approximately four grams of thorium-232 in either argon or mineral oil. In this second embodiment, the anode is also aluminium and contains at least 4 grams of phosphorus-15 and at least 2 grams of thorium-232 in argon or mineral oil. Alternatively, mesothorium may be used for the thorium, strontium-38 may be used for the rubidium, and sulphur-16 may be used for the phosphorus. Rods **71** and **79** extend through cylinder head **17** to the exterior where electrical connections are made to the electrodes. Each rod is surrounded by one of four insulating sleeves **83**, the lower portion of each of which being flared outwards to seat firmly in the cylinder head.

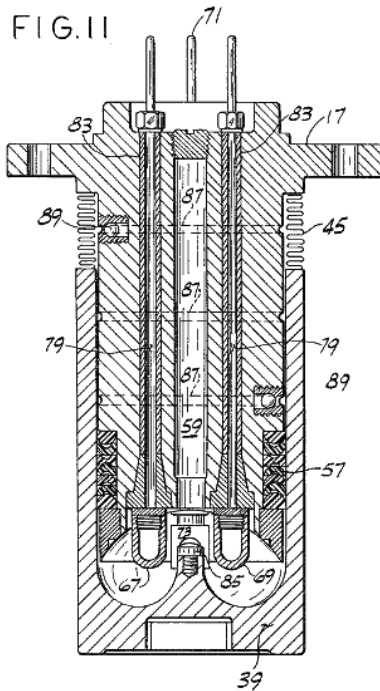

The piston has a generally semi-toroidal depression in its upper surface (see **Fig.4**, **Fig.5** and **Fig.11**) and carries a conductive discharge point **85** of copper, brass or bronze generally along the axis of the chamber. When the piston is generally extended, the discharge point is a substantial distance from the electrodes. But when the piston is in its upper position (see **Fig.11**), the discharge point is positioned generally between all four electrodes and close to them, there being gaps between the electrodes and the discharge point. When the piston is in this upper position, the electrodes extend somewhat into the semi-toroidal depression in the piston's upper surface and the chamber is generally toroidal in shape. The volume of the chamber shown in **Fig.11** can be from approximately 6.0 cubic inches (100 cc) or larger. Given the present state of the art, 1500 cubic inches (25,000 cc) appears to be the upper limit. A plurality of ports **87** and one-way valves **89** return working fluid which escapes from the chamber back into it, so long as a sealing system such as bellows **45** is used.

An alternative cylinder head/piston arrangement is shown in **Fig.12**. The main difference between this arrangement and that of **Fig.5** is that the chamber walls, here labelled **43'** are integrally formed with the head. As a result seals **57** are carried by the piston rather than by the head, the attachment of bellows **45** is somewhat different, and the fluid-returning valves and ports are part of the piston rather than of the head. Otherwise these arrangements are substantially the same. Preferably, the cylinders of both arrangements are hermetically sealed.

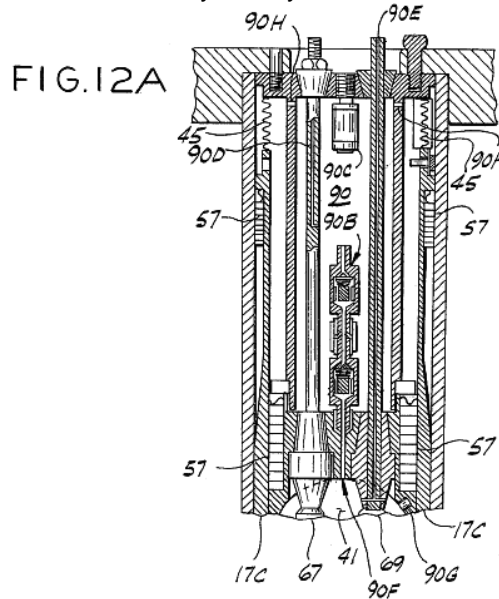

An additional embodiment of a cylinder head/piston arrangement used in the present invention is shown in **Fig.12A**. In this arrangement, a tapered sleeve **17C** mates between cylinder head **17** and piston **39**, a plurality of seals **57** are provided, and electrodes **67** and **69** have a somewhat different shape. Also, in this embodiment, a chamber **90** is provided in cylinder head **17** for storing additional working fluid, i.e., the purpose of chamber **90** is to extend the operating time between refuelling by circulating the working fluid, viz. the mixture of inert gases

described, between cylinder **41** and chamber **90** as needed so that the reactions in cylinder **41** are not adversely affected. To accomplish this, this embodiment further includes a two-way circulation valve **90B**, a relief valve **90C**, and duct or passageway **90D** for evacuating and filling chamber **90**, a duct or passageway **90E** for evacuating and filling cylinder **41**, a passageway **90F** between chamber **90** and cylinder **41** in which two-way valve **90B** is disposed, a sensor **90G** and a plurality of small pressure relief holes **90H**. Relief holes **90H** serve to relieve the pressure on bellows **45** as the piston moves from BDC to TDC.

In larger engines holes **90H** should be replaced with one way valves. Two-way valve **90B** is either controlled by sensor **90G** or is manually operated, as desired, to allow the circulation of gases between chamber **90** and cylinder **41**. The sensor itself detects a condition requiring the opening or closing of valve **90B** and signals that condition to the valve. For example, sensor **90G** can measure pressure in cylinder **41** while the piston is at top dead centre. A predetermined cylinder pressure can cause a spring to compress, causing the valve to open or close as appropriate. A subsequent change in the cylinder pressure would then cause another change in the valve. Another sensor (not shown) could measure the physical location of the piston by a physical trip switch or an electric eye, or it could measure angular distance from top dead centre on the distributor or the crankshaft. The sensor must keep the gas pressure in chamber **90** at one atmosphere, plus or minus 5%, and at top dead centre, cylinder **41** should also be at that pressure. If gas is lost from the system, it is more important to maintain the proper pressure in cylinder **41**. Alternatively, a small passage between cylinder **41** and chamber **90** could function in a passive manner to satisfactorily accomplish the same result. From the above, it can be seen that this embodiment utilises the hollowed out centre of the cylinder head for storing additional working fluid, which fluid is circulated between chamber **90** and cylinder **41** through a valve system comprising valve **90B** and sensor **90G** with the moving piston causing the gases to circulate.

The electrical circuitry for engine **11** includes (see **Fig.13A**) a 24 V battery **B1**, an ignition switch **SW1**, a starter switch **SW2**, starter motor **37**, a main circuit switch **SW4**, a step-down transformer **93** (e.g., a 24 V to 3.5 V transformer), a switch **SW6** for supplying power to ignition coil **25** (shown in **Fig.13A** and **Fig.13B** as two separate ignition coils **25A** and **25B**), and various decoupling diodes.

The circuitry of **Fig.13A** also includes a high frequency voltage source or oscillator **95** for supplying rapidly varying voltage through two electronic current regulators **97A**, **97B** (see **Fig.13B** for regulator **97B**) to the anode and cathode electrodes of each cylinder, and a high-voltage distributor **99** for distributing 40,000 volt pulses to the cylinders. Distributor **99** has two wipers **99A** and **99B** and supplies three pulses to each cylinder per cycle. Wipers **99A** and **99B** are 180 degrees out of phase with each other and each operates to supply pulses to its respective cylinder from TDC to 120 degrees thereafter. More pulses are desirable and therefore a better distributor arrangement (shown in **Fig.14**) may be used. The arrangement shown in **Fig.14** includes two ignition coils **101**, **103**, a simple distributor **105** and a pair of magnetic ignition circuits **107** and **109**, described below. Of course many other ignition systems could also be developed. For example, a single circuit might be used in place of circuits **107**, **109**, additional induction coils might be added to the ignition coils to assist in starting or a resistor could be added to the ignition coils to ensure a constant 40,000 volt output regardless of engine rpm. Also, a solid-state distributor could be used instead of the mechanical distributor labelled **99**.

A pair of low-voltage distributors **135** and **137** are also shown in **Fig.13A**. Distributors **135** and **137** provide gating pulses for the electronic switching units of **Fig.13A** and **Fig.13B**. Of course, solid-state distributors could also replace mechanical distributors **135** and **137**.

In addition, the engine circuitry includes (see **Fig.13B**) five electronic switching units **143**, **145**, **147**, **149** and **151** corresponding to units **113**, **115**, **117**, **119** and **121** of **Fig.13A**, electrodes **63** and **65** of the "B" cylinder, anode **67**, cathode **69**, electric coils **49B**, **51B** and **53B**, capacitors **C1B** and **C2B**, and various decoupling diodes. The circuitry of **Fig.13B** is generally the same as the corresponding portions of **Fig.13A**, so the description of one for the most part applies to both. Of course, if more than two cylinders are used, each pair of cylinders would have associated with them, circuitry such as that shown in **Fig.13A** and **Fig.13B**. The circuitry of **Fig.13A** is connected to that of **Fig.13B** by the lines **L1-L17**.

The working fluid and the fuel for the engine are one and the same and consist of a mixture of inert gases, which mixture consists essentially of helium, neon, argon, krypton and xenon. It is preferred that the mixture contain 35.6% helium, 26.3% neon, 16.9% argon, 12.7% krypton, and 8.5% xenon by volume, it having been calculated that this particular mixture gives the maximum operation time without refuelling. Generally, the initial mixture may contain, by volume, approximately 36% helium, approximately 26% neon, approximately 17% argon, approximately 13% krypton, and approximately 8% xenon. This mixture results from a calculation that equalises the total charge for each of the gases used after compensating for the fact that one inert gas, viz. radon, is not used. The foregoing is confirmed by a spectroscopic flashing, described below, that occurs during the mixing process. If one of the gases in the mixture has less than the prescribed percentage, it will become over-excited. Similarly, if one of the gases has more than the prescribed percentage, that gas will be under-excited. These percentages do not vary with the size of the cylinder.

Operation of the engine is as follows: At room temperature, each cylinder is filled with a one atmosphere charge of the fuel mixture of approximately 6 cubic inches (100 cc) /cylinder (in the case of the smallest engine) by means of filler tube **59**. The filler tubes are then plugged and the cylinders are installed in the engine as shown in **Fig.4**, one piston being in the fully extended position and the other being in the fully retracted position. To start the engine, the ignition and starter switches are closed, as is switch **SW6**. This causes the starter motor to crank the engine, which in turn causes the wiper arms of the distributors to rotate. The starting process begins, for example, when the pistons are in the positions shown in **Fig.4**. Ignition coil **25** and distributor **99** (see **Fig.13A**) generate a 40,000 volt pulse which is supplied to electrode **65** of chamber **41A**. Therefore, a momentary high potential exists between electrodes **63** and **65** and the plates on each. The discharge point on piston **39A** is adjacent these electrodes at this time and sparks occur between one or more of the electrodes and the discharge point to partially excite, e.g. ionise, the gaseous fuel mixture.

The gaseous fuel mixture in cylinder **41A** is further excited by magnetic fields set up in the chamber by coil **49A**. This coil is connected to the output side of electronic switching unit **121** and, through switching unit **113**, to the battery and the generator. At this time, i.e., between approximately 5 degrees before TDC and TDC, distributor **135** is supplying a gating signal to unit **121**. Any current present on the input side of unit **121**, therefore, passes through unit **121** to energise coil **49A**. Moreover, high frequency current from oscillator **95** is supplied via regulator **97A** to coil **49A**. This current passes through regulator and relay **97A** because the gating signal supplied from distributor **135** to unit **121** is also supplied to relay **97A**. The current from switching unit **121** and from oscillator **95** also is supplied to the anode and the cathode. It is calculated that this causes radioactive rays (x-rays) to flow between the anode and the cathode, thereby further exciting the gaseous mixture.

As the starter motor continues cranking, piston **39A** begins moving downward, piston **39B** begins moving upward, and the wiper arms of the distributors rotate. (Needless to say, a solid-state distributor would not rotate. The distributor could utilise photo cells, either light or reflected light, rather than contact points). After 45 degrees of rotation, distributor **135** supplies a gating pulse to electronic switching unit **119**, thereby completing a circuit through unit **119**. The input to unit **119** is connected to the same lines that supply current to coil **49A**. The completion of the circuit through unit **119**, therefore, causes coil **51A** to be energised in the same manner as coil **49A**. After an additional 45 degrees of rotation, distributor **135** gates on electronic switching unit **117** which completes a circuit to the same lines. The output terminal of unit **117** is connected to coil **53A**, and so this coil is energised when unit **117** is gated on. All three coils of the "A" cylinder remain energised and, therefore, generating magnetic fields in chamber **41A** until piston **39A** reaches BDC.

As piston **39A** moves from TDC to BDC, two additional 40,000 volt pulses (for a total of three) are supplied from distributor **99** to the "A" cylinder. These pulses are spaced approximately 60 degrees apart. If more pulses are desired, the apparatus shown in **Fig.14** may be used. In that case, the solenoids indicated generally at **107A**, **107B** and **109A**, **109B** are energised to create a number of rapid, high-voltage pulses which are supplied as indicated in **Fig.14** to the cylinders, distributor **105** operating to supply pulses to only one of the pair of cylinders at a time.

As piston **39A** reaches BDC, distributor **135** sends a pulse to the OFF terminals of electronic switching units **121**, **117** and **119**, respectively, causing all three coils **49A**, **51A** and **53A** to be de-energised. At about the same time, i.e., between approximately 5 degrees before TDC and TDC for piston **39B**, distributor **137** supplies a gating pulse to the ON terminals of electronic switching units **113** and **115**. The power inputs to units **113** and **115** come from the generator through regulator **111** and from the battery, and the outputs are directly connected to coils **49A** and **53A**. Therefore, when units **113** and **115** are gated on, coils **49A** and **53A** are reenergised. But in this part of the cycle, the coils are energised with the opposite polarity, causing a reversal in the magnetic field in chamber **41A**. Note that coil **51A** is not energised at all during this portion of the cycle. Capacitors **C1A** and **C2A** are also charged during the BDC to TDC portion of the cycle. (During the TDC to BDC portion of the cycle, these capacitors are charged and/or discharged by the same currents as are supplied to the anode and cathode since they are directly connected to them).

As piston **39A** moves upwards, electrodes **63** and **65** serve as pick-up points in order to conduct some of the current out of chamber **41A**, this current being generated by the excited gases in the chamber. This current is transferred via line **L7** to electronic switching unit **151**. The same gating pulse which gated on units **113** and **115** was also supplied from distributor **137** via line **L12** to gate on switching unit **151**, so the current from the electrodes of chamber **41A** passes through unit **151** to the anode, cathode and capacitors of chamber **41B**, as well as through switching units **147** and **149** to coils **49B**, **51B** and **53B**. Thus it can be seen that electricity generated in one cylinder during a portion of the cycle is transferred to the other cylinder to assist in the excitation of the gaseous mixture in the latter. Note that this electricity is regulated to maintain a constant in-engine current. It should be noted, that twenty four volts from the generator is always present on electrodes **63** and **65** during operation to provide for pre-excitement of the gases.

From the above it can be seen that distributors **135** and **137** in conjunction with electronic switching units **113**, **115**, **117**, **119**, **121**, **143**, **145**, **147**, **149** and **151** constitute the means for individually energising coils **49A**, **49B**, **51A**, **51B**, **53A** and **53B**. More particularly, they constitute the means to energise all the coils of a given cylinder from the other cylinder when the first cylinder's piston is moving from TDC to BDC and operate to energise only two (i.e., less than all) of the coils from the alternator when that piston is moving from BDC to TDC. Additionally, these components constitute the means for energising the coils with a given polarity when the piston of that cylinder is moving from TDC to BDC and for energising the first and third coils with the opposite polarity when that piston is moving from BDC to TDC.

As can also be seen, switching units **121** and **151** together with distributors **135** and **137** constitute the means for closing a circuit for flow of current from chamber **41A** to chamber **41B** during the BDC to TDC portion of the cycle of chamber **41A** and for closing a circuit for flow of current from chamber **41B** to chamber **41A** during the TDC to BDC portion of the cycle of chamber **41A**. Oscillator **95** constitutes the means for supplying a time varying electrical voltage to the electrodes of each cylinder, and oscillator **95**, distributors **135** and **137**, and regulators **97A** and **97B** together constitute the means for supplying the time varying voltage during a predetermined portion of the cycle of each piston. Moreover, distributor **99** together with ignition coils **25A** and **25B** constitute the means for supplying high-voltage pulses to the cylinders at predetermined times during the cycle of each piston.

The cycle of piston **39B** is exactly the same as that of piston **39A** except for the 180 degree phase difference. For each cylinder, it is calculated that the excitation as described above causes the gases to separate into layers, the lowest atomic weight gas in the mixture, namely helium, being disposed generally in the centre of each chamber, neon forming the next layer, and so on until we reach xenon which is in physical contact with the chamber walls. The input current (power) to do this is the calculated potential of the gas mixture. Since helium is located in the centre of the chamber, the focal point of the electrode discharges and the discharges between the anode and cathode is in the helium layer when the piston is near TDC. As the piston moves slightly below TDC, the electrons from electrodes **63** and **65** will no longer strike the tip of the piston, but rather will intersect in the centre of the cylinder (this is called "focal point electron and particle collision") as will the alpha, beta and gamma rays from the anode and cathode. Of course, the helium is in this exact spot and is heavily ionised at that time. Thus the electrodes together with the source of electrical power connected thereto constitute the means for ionising the inert gas.

It is calculated that as a result of all the aforementioned interactions, an ignition discharge occurs in which the helium splits into hydrogen in a volume not larger than 2 or 3 x 10⁻⁶ cubic millimetres at a temperature of approximately 100,000,000 degrees F. Of course this temperature is confined to a very small space and the layering of the gases insulates the cylinder walls from it. Such heat excites the adjacent helium so that a plasma occurs. Consequently, there is a minute fusion reaction in the helium consisting of the energy conversion of a single helium atom, which releases sufficient energy to drive the piston in that chamber toward BDC with a force similar in magnitude to that generated in a cylinder of a conventional internal combustion engine. Electrodes **63** and **65** extend into the argon layer while each piston is in its BDC to TDC stroke so as to pick up some of the

current flowing in that layer. It may take a cycle or two for the gases in the cylinders to become sufficiently excited for ignition to occur.

Once ignition does occur, the electrical operation of the engine continues as before, without the operation of the starter motor. Distributor **99** supplies three pulses per cycle (or more if the magnetic ignition system of **Fig.14** is used) to each cylinder; and distributors **135** and **137** continue to supply "on" and "off" gating pulses to the electronic switching units. The rpm of the engine is, as explained above, governed by the frequency of the current from oscillator **95** (or in the case of smaller horsepower units, by the DC voltage supplied to the cylinders from the Variac).

Because of the minute amount of fuel consumed in each cycle, it is calculated that a cylinder can run at 1200 rpm approximately 1000 hours, if not more, on a single charge of gas. Note that even at 1200 rpm, there will be intense heat occurring only 0.002% of the time. This means that input power need be applied only sporadically. This power can be supplied to a cylinder from the other cylinder of its pair by means of electronic switching units which, in the case of SCRs, are themselves triggered by low voltage (e.g. 3.5 V) current. Thus, since electrical power generated in one cylinder is used to excite the gases in the other cylinder of a pair, it is practical that the cylinders be paired as discussed above. Capacitors are, of course, used to store such energy for use during the proper portion of the cycle of each cylinder.

From the above, it should be appreciated that the engine of this invention has several advantages over presently proposed fusion reactors, such as smaller size, lower energy requirements, etc. But what are the bases of these advantages? For one, presently proposed fusion reactors use hydrogen and its isotopes as a fuel instead of inert gases. Presumably this is because hydrogen requires less excitement power. While this is true, the input power that is required in order to make hydrogen reactors operate makes the excitation power almost insignificant. For example, to keep a hydrogen reactor from short circuiting, the hydrogen gas has to be separated from the reactor walls while it is in the plasma state. This separation is accomplished by the maintenance of a near vacuum in the reactor and by the concentration of the gas in the centre of the reactor (typically a toroid) by a continuous, intense magnetic field. Accordingly, separation requires a large amount of input energy.

In the present invention, on the other hand, the greater excitation energy of the fuel is more than compensated for by the fact that the input energy for operation can be minimised by manipulation of the unique characteristics of the inert gases. First, helium is the inert gas used for fusion in the present invention. The helium is primarily isolated from the walls of the container by the layering of the other inert gases, which layering is caused by the different excitation potential (because of the different atomic weights) of the different inert gases, said excitation being caused by the action of the electrodes, anode and cathode in a magnetic field. This excitation causes the gases each to be excited in inverse proportion to their atomic numbers, the lighter gases being excited correspondingly more. Helium, therefore, forms the central core with the other four gases forming layers, in order, around the helium. The helium is secondarily isolated from the walls of the container by a modest vacuum (in comparison to the vacuum in hydrogen reactors) which is caused partially by the "choking" effect of the coils and partially by the enlargement of the combustion chamber as the piston moves from TDC to BDC. (Unexcited, the gases are at one atmosphere at TDC). Second, argon, the middle gas of the five, is a good electrical conductor and becomes an excellent conductor when (as explained below) it is polarised during the mixing process. By placing the electrodes such that they are in the argon layer, electrical energy can be tapped from one cylinder for use in the other. During a piston's movement from BDC to TDC, the gases are caused to circulate in the cylinder by the change in the polarity of the coils, which occurs at BDC.

During such circulation, the gases remain layered, causing the argon atoms to be relatively close to each other, thereby optimising the conductivity of the argon. This conductivity optimisation is further enhanced by a mild choking effect that is due to the magnetic fields. The circulation of the highly conductive argon results in a continuous cutting of the magnetic lines of force so that the current flows through the electrodes. This production of electricity is similar to the rotating copper wire cutting the magnetic lines of force in a conventional generator except that the rotating copper wire is replaced by the rotating, highly conductive argon. The amount of electricity that can be produced in this manner is a function of how many magnetic field lines are available to be cut. If one of the coils, or all three of the coils or two adjacent coils were energised, there would be only one field with electricity produced at each end. By energising the top and the bottom coil, two separate fields are produced, with electricity produced at four points.

A five coil system, if there were sufficient space, would produce three fields with the top, bottom and middle coils energised. Six points for electricity production would result. The number of coils that can be installed on a given cylinder is a function of space limitations. The recombination of gas atoms during the BDC to TDC phase causes the radiation of electrical energy which also provides a minor portion of the electricity that the electrode picks up. Additional non-grounded electrodes in each cylinder would result in more electricity being tapped off. It should be noted that during the BDC to TDC phase, the anode and the cathode are also in the argon layer and, like the electrodes, they pick up electricity, which charges the capacitors around the cylinder. Third, inert gases remain a

mixture and do not combine because of the completeness of the electron shells. They are therefore well suited to a cycle whereby they are continually organised and reorganised. Fourth, as the helium atoms are consumed, the other gases have the capacity to absorb the charge of the consumed gas so that the total charge of the mixture remains the same.

The second basis of these advantages of the present engine over proposed fusion reactors concerns the fact that hydrogen reactors develop heat which generates steam to turn turbines in order to generate electrical power. This requires tremendous input energy on a continuous basis. The present invention operates on a closed cycle, utilising pistons and a crankshaft which does not require a continuous plasma but rather an infrequent, short duration (10^{-6} second) plasma that therefore requires much less input energy. In the present invention, a plasma lasting longer than 10^{-6} second is not necessary because sufficient pressure is generated in that time to turn the engine. A plasma of longer duration could damage the engine if the heat were sufficiently intense to be transmitted through the inert gas layers to the cylinder walls. A similar heat build-up in the engine can occur if the repetition rate is increased. Such an increase can be used to increase the horsepower per engine size but at the cost of adding a cooling system, using more expensive engine components, and increasing fuel consumption. Note that even though layers of inert gases insulate the cylinder walls, there might be some slight increase in the temperature of the gas layers after a number of cycles, i.e., after a number of ignitions.

Whereas hydrogen fusion reactors cannot directly produce power by driving a piston (because of the required vacuum), the present invention uses the layered inert gases to transmit the power from the plasma to each gas in turn until the power is applied to a piston, which can easily be translated into rotary motion. The layered gases also cushion the piston from the full force of the ignition. Moreover, the fields inside the cylinder undergoing expansion cause the gases to shrink, thereby taking up some of the pressure generated by the explosion and preventing rupturing of the cylinder walls.

Turning now to **Fig.17A** to **Fig.17D**, there is shown apparatus **201** for preparing the fuel mixture for engine **11**. For convenience apparatus **201** is called a mixer although it should be understood that the apparatus not only mixes the gases which form the fuel but also performs many other vital functions as well. The five constituent inert gases are introduced in precise, predetermined proportions. The mixer extracts, filters and neutralises the non-inert gases and other contaminants which may be found in the gas mixture. It also increases the potential capacity of gas atoms, discharges the krypton and xenon gases, polarises the argon gases, ionises the gases in a manner such that the ionisation is maintained until the gas has been utilised and otherwise prepares them for use as a fuel in engine **11**. In particular, the mixer makes the gases easier to excite during operation of the engine. Mixing does not mean an atomic or molecular combination or unification of gases because inert gases cannot chemically combine, in general, due to the completeness of the outer shell of electrons. During mixing, the various gases form a homogeneous mixture. The mixing of the five inert gases in apparatus **201** is somewhat analogous to preparing a five part liquid chemical mixture by titration. In such a mixture, the proportions of the different chemicals are accurately determined by visually observing the end point of each reaction during titration. In apparatus **201**, a visible, spectroscopic flash of light accompanies the desired end point of the introduction of each new gas as it reaches its proper, precalculated proportion. (Each gas has its own distinctive, characteristic, spectroscopic display). The ends points are theoretically calculated and are determined by pre-set voltages on each of a group of ionising heads in the apparatus, as described below.

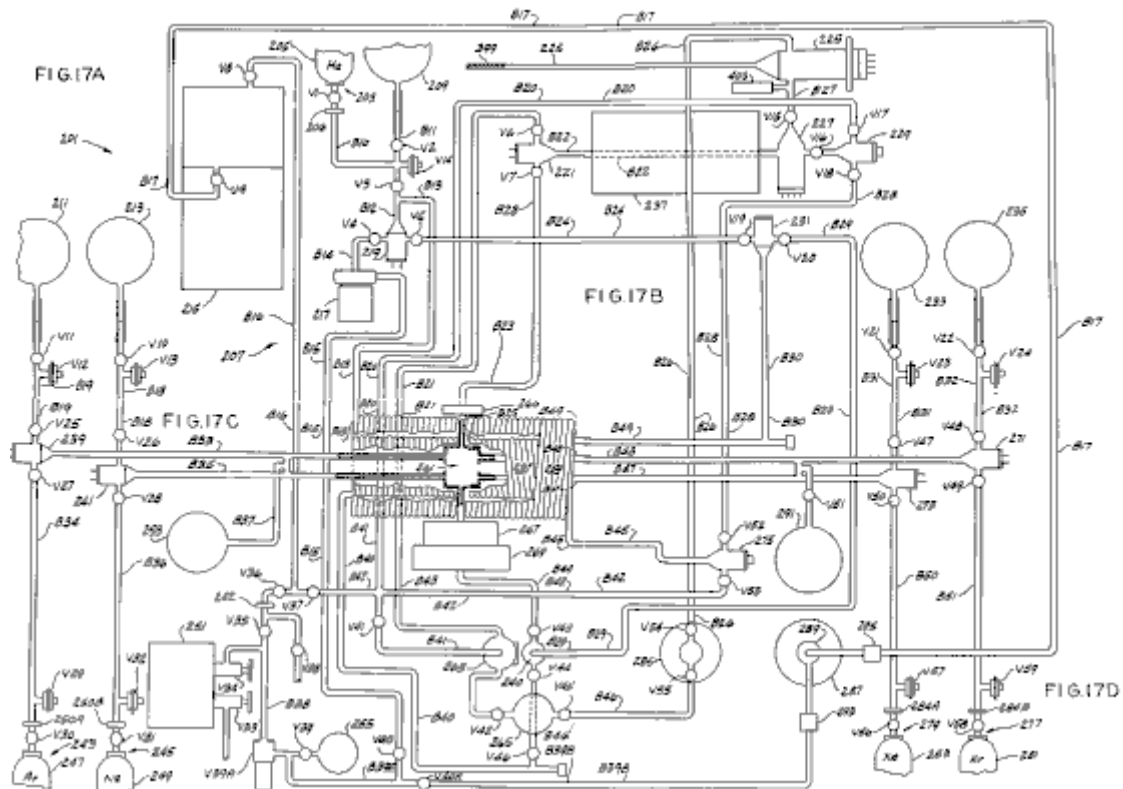

Mixer **201** includes (see **Fig.17A**) an intake port, indicated generally at **203**, which during operation is connected to a source **205** of helium gas, a gauge **206**, glass tubing **207** comprising a plurality of branches **B10-B25** for flow of the gases through the mixer, a plurality of valves **V1-V11** in the branches, which valves may be opened or closed as necessary, three gas reservoirs **209**, **211** and **213** for storing small quantities of helium, argon and neon gas respectively, an ionising and filtering unit **215** for filtering undesired non-inert gases and contaminants out of the fuel mixture, for regulating the gas atom electron charge and to absorb the free flowing electrons, a gas flow circulation pump **217**, two ionising heads **219** and **221**, and three quality control and exhaust valves **V12-V14**. The mixer also comprises (see **Fig.17B**) a high frequency discharge tube **225**, a non-directed cathode ray tube **227**, two more ionising heads **229** and **231**, two additional gas reservoirs **233** and **235** for storing small quantities of xenon and krypton, a quadruple magnetic coil **237**, a group of valves **V15-V24**, valves **V23** and **V24** being quality control and exhaust valves, and a plurality of additional glass tubing branches **B26-B32**.

Turning to **Fig.17C**, mixer **201** also includes additional ionising heads **239**, **240** and **241**, additional valves **V25-V46**, **V39A** and **V40A**, valves **V29** and **V32** being quality control and exhaust valves and valve **V39A** being a check valve, a vacuum and pressure gauge **242** between valves **V35** and **V36**, tubing branches **B34-B49** (branch **B39** consisting of two parts **B39A** and **B39B**), a pair of intake ports **243** and **245** which during operation are connected to sources **247** and **249** of argon and neon gas respectively, gauges **250A** and **250B**, a spark chamber **251**, a hydrogen and oxygen retention chamber **253** containing No. 650 steel dust in a silk filter, an ion gauge **255** (which can be an RG 75K type Ion Gauge from Glass Instruments, Inc. of Pasadena, Calif.) for removing excess inert gases from the mixture, inner and outer coils of glass tubing **257** and **259** surrounding a mixing chamber **261**, a focused x-ray tube **263** for subjecting the mixture flowing through it to 15-20 millirem alpha radiation and 120-125 millirem beta radiation, a directed cathode ray tube **265**, two twin parallel magnetic coils **266** and **267**, and a focusing magnetic coil **269**. It is important that coils **266** and **267** be immediately adjacent mixing chamber **261**. And (see **Fig.17D**) the mixer also comprises three more ionising heads **271**, **273** and **275**, two entry ports **277** and **279** which during operation are connected to sources **281** and **283** of krypton and xenon respectively, gauges **284A** and **284B**, a high frequency discharge tube **285**, a twin parallel magnetic coil **287** surrounding a polariser **289** for polarising the argon, said polariser containing fine steel particles which are polarised by coils **287** and which in turn polarise argon, a second hydrogen retention chamber **291**, a pair of tubing branches **B50** and **B51**, two filters **293** and **295** and a plurality of valves **V47-V59**, valves **V57** and **V59** being quality control and exhaust valves.

Inner and outer glass tubing coils **257** and **259** and mixing chamber **261** are shown in cross section in **Fig.18**. Intermediate glass coils **257** and **259** are two magnetic coils **297** and **299** having an inductance of approximately 130 mH. A yoke coil **301** is positioned in a semi-circle around mixing chamber **261**. Inside mixing chamber **261** are located a pair of screens **303** and **305**, insulators **307** and **309**, and a pair of spark gaps indicated generally at **311** and **313**. A high frequency amplitude modulated source provides 120 V AC, 60 Hz, 8.4 amp, 560 watt, 27,120 to 40,000 MHz plus or minus 160 KHz current via heavily insulated wires **315** and **317** to the chamber.

These wires are about twelve gauge, like those used as spark plug wires on internal combustion engines. Additionally 95 volt Direct Current is supplied via a smaller (e.g. sixteen to eighteen gauge) insulated wire **319**. As described below, the gases to be mixed and prepared flow through chamber **261** and are suitably treated therein by the action of the various fields present in the chamber.

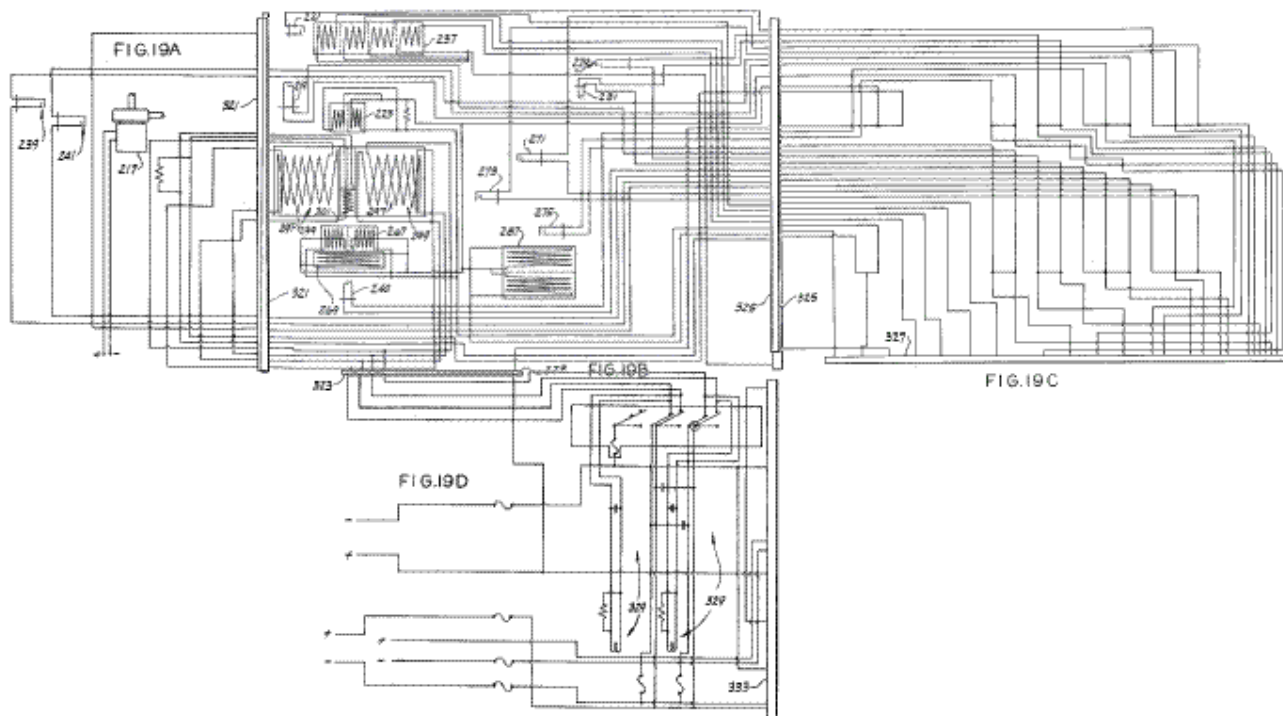

The magnetic coils, ionisation heads, and pump **217**, along with the required electrical interconnections, are schematically shown in **Fig.19A** to **Fig.19E**. More particularly, heads **239** and **241** are shown in **Fig.19A**, as is pump **217**. Each ionising head has two electrodes with a gap between them to cause ionisation of gases flowing through the head, the electrodes being connected to a source of electrical power. Pump **217** is directly connected to a source of power (either AC or DC as required by the particular pump being used). The connections between the circuitry on **Fig.19A** and that on **Fig.19B** are shown as a plug **321**, it being understood that this plug represents a suitable one-to-one connection between the lines of **Fig.19A** and those of **Fig.19B**.

The remaining ionising heads and all the magnetic coils are shown in **Fig.19B**. For clarity, the coils are shown in an unconventional form. Quadruple coil **237** (shown at the top of **Fig.19B**) has one side of each winding connected in common but the other sides are connected to different lines. Coil **223** consists of two windings in parallel. Coils **297** and **299**, the ones around the mixing chamber, are shown overlapping, it being understood that coil **297** is actually interior of coil **299**. Yoke coil **301**, as shown, extends half-way from the bottom to the top of coils **297** and **299**. Twin parallel magnetic coils **267** are connected in parallel with each other, both sides of focusing coil **269** being connected to one node of coils **267**. Likewise coils **287** are connected in parallel. The connections between the lines of **Fig.19B** and those of **Fig.19C** and **Fig.19D** are shown as plugs **323** and **325**, although other suitable one-to-one connections could certainly be made. **Fig.19C** shows the interconnecting lines between **Fig.19B** and **Fig.19E**. A plug **327** or other suitable one-to-one connections connects the lines of **Fig.19C** and **Fig.19E**.

A plurality of power sources, like the above-mentioned Variacs, of suitable voltages and currents as well as a plurality of relays **329**, and plugs **331** are shown on **Fig.19D** and **Fig.19E**. The connections between these two Figures is shown as a plug **333**. It should be appreciated that the Variacs can be adjusted by the operator as necessary to supply the desired voltages to the aforementioned coils and ionising heads. It should also be realised that the desired relays can be closed or opened as needed by connecting or disconnecting the two parts of the corresponding plug **331**. That is, by use of plugs **331**, the operator can control the energising of the ionising heads and magnetic coils as desired. Plugs **331** are also an aid in checking to ensure that each component is in operating condition just prior to its use. Of course, the manipulation of the power sources and the relays need not be performed manually; it could be automated.

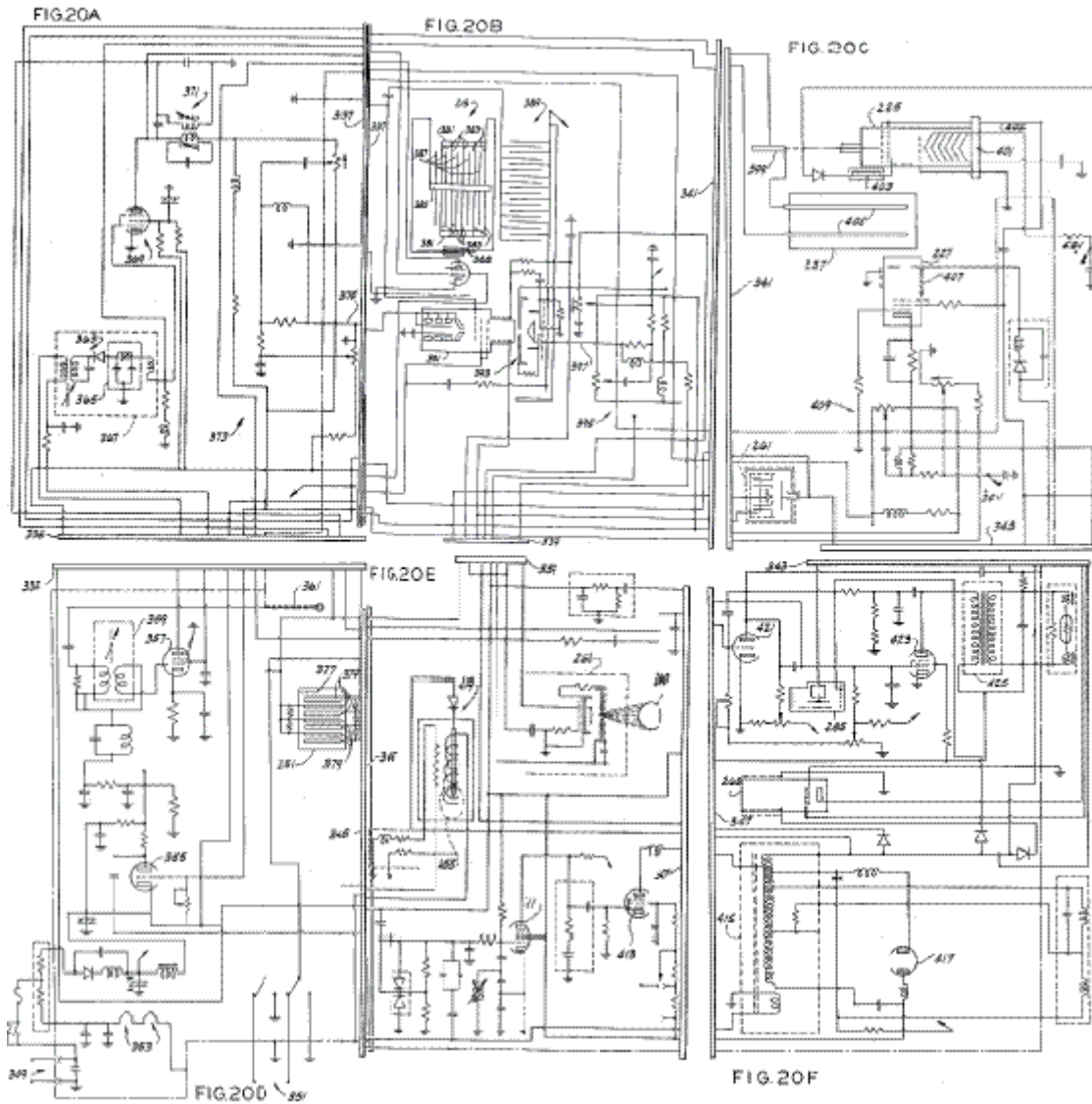

The remaining circuitry for the mixer is shown on **Fig.20A** to **Fig.20F**. For convenience, plugs **335**, **337**, **339**, **341**, **343**, **345** and **347** are shown as connecting the circuitry shown in the various Figures, although other suitable one-to-one connections may be used. The chassis of the apparatus is shown on these Figures in phantom and is grounded. The power supply for the apparatus is shown in part on **Fig.20A** and **Fig.20D** and includes an input **349** (see **Fig.20D**) which is connected to 120 volt, 60 Hz power during operation and an input **351** which is connected to the aforementioned high frequency generator or some other suitable source of approximately 27,120 MHz current. The power supply includes a pair of tuners **353**, numerous RLC circuits, a triode **355**, a pentode **357** with a ZnS screen, a variable transformer **359**, an input control **361**, a second variable transformer **363** (see **Fig.20A**) which together with a filter **365** forms a 2.0 volts (peak-to-peak) power supply **367**, a pentode **369**, a variable transformer **371**, and a resistor network indicated generally at **373**. Exemplary voltages in the power supply during operation are as follows: The anode of triode **355** is at 145 V, the control grid at 135 V and the cathode at -25 V. The voltage at the top of the right-hand winding of transformer **359** is -5 V. The anode of pentode **357** is at 143 V, the top grid is grounded (as is the ZnS screen), the bottom grid is connected to transformer **359**, and the control electrode is at 143 V. The input to supply **367** is 143 volts AC while its output, as stated above, is 2 V (peak-to-peak). The anode of pentode **369** is at 60 V, the grids at -1.5 V, the control electrode at 130 V, and the cathode is substantially at ground. The output of resistor network **373**, labelled **375**, is at 45 V.

Also shown on **Fig.20D** is spark chamber **251**. Spark chamber **251** includes a small amount of thorium, indicated at **377**, and a plurality of parallel brass plates **379**. When the gases in the mixer reach the proper ionisation, the alpha particles emitted by the thorium show up as flashes of light in the spark chamber.

Turning now to **Fig.20B**, ionising and filtering unit **215** includes a pair of conductive supports **381** for a plurality of conductors **383**, said supports and conductors being connected to a voltage source, an insulating support **385** for additional conductors **387**, and a ZnS screen **388** which emits light when impurities are removed from the gaseous fuel mixture. Unit **215** also includes a second set of interleaved conductors indicated generally at **389**, a

cold-cathode tube **391**, and an x-ray tube indicated generally at **393**. Also shown on **Fig.20B** is an RLC network **395** which has an output on a line **397** which is at 35 V, this voltage being supplied to the x-ray tube.

High frequency discharge tube **255** (see **Fig.20C**) has a conductive electrode **399** at one end to which high frequency current is applied to excite the gases in the mixer, and an electrode/heater arrangement **401** at the other, a voltage of 45 V being applied to an input **402** of the tube. It is desirable that a small quantity of mercury, indicated at **403**, be included in tube **225** to promote discharge of the helium gas. Magnetic coils **237** have disposed therein a pair of generally parallel conductors **405** to which a high frequency signal is applied. When gas flows through coils **237** and between parallel conductors **405**, therefore, it is subjected to the combination of a DC magnetic field from the coil and high frequency waves from the conductors, which conductors act as transmitting antennas. The resulting high frequency magnetic field causes the atoms to become unstable, which allows the engine to change a given atom's quantum level with much less input power than would normally be required. The volume of each gas atom will also be smaller. Also shown on **Fig.20C** is non-directed cathode ray tube **227**. The grids of tube **227** are at 145 V, the control electrode is at ground, while the anode is at 35 V to 80 V (peak-to-peak). The purpose of non-directed cathode ray tube **227** is to add photons to the gas mixture. To generate these photons, tube **227** has a two layer ZnS coating indicated generally at **407**. Chamber **261**, described above, is also shown schematically on **Fig.20C**, along with an RLC network **409**.

The power supply for the mixer (see the lower halves of **Fig.20E** and **Fig.20F**) also includes two pentodes **411** and **413**, a transformer **415**, and a diode tube **417**. The control electrode of pentode **411** is at 5 V to 40 V (peak-to-peak), the grids are at 145 V, the anode is at 100 V, and the cathode is at 8 V to 30 V (peak-to-peak). The control electrode of pentode **413** is at 115 V, while its grids and cathode are at -33 V. The anode of tube **413** is connected to transformer **415**. Also shown on **Fig.20E** are a relay **419** associated with ion gauge **255**, and focused x-ray tube **263** associated with ionisation head **240**. The upper input to tube **263** is at 45 V to 80 V (peak-to-peak).

Turning to **Fig.20F**, there is shown tubes **265** and **285**. Directed cathode ray tube **265** is a pentode connected like tube **227**. High frequency discharge tube **285** includes a phosphor screen and is connected to a high frequency source. Also shown on **Fig.20F** is a triode **421** with its anode at 30 V, its cathode at ground, and its control grid at -60 V; a pentode **423** with its anode at 135 V to 1000 V peak to peak, its cathode at ground, its control electrode at 143 V, its grids at 20 V; and a transformer **425**. It should be understood that various arrangements of electrical components other than those described above could be designed to perform the same functions.

The operation of the mixer is best understood with reference to **Fig.17A** to **Fig.17D** and is as follows: Before and during operation, the mixer, and particularly chamber **261** is kept hermetically sealed and evacuated. To begin the mixing process, helium is admitted into the mixer via intake port **203**. Then a vacuum is again drawn, by a vacuum pump (not shown) connected to valve **V38**, to flush the chamber. This flushing is repeated several times to completely cleanse the tubing branches of the mixer. The mixer is now ready. The ionisation heads next to mixing chamber **261** are connected to a voltage corresponding to approximately 36% of the calculated total ionising voltage, DC current is allowed to flow through magnetic coils **297** and **299** around chamber **261**, and high frequency current is allowed to pass through the mixing chamber. Helium is then slowly admitted, via port **203**, into the mixer. From port **203**, the helium passes through ionisation head **219** into glass tubing coil **259**. This glass coil, being outside magnetic coils **297** and **299**, is in the diverging portion of a magnetic field. The helium slowly flowing through glass coil **259** is gently excited. From coil **259**, the helium flows through branch **B45** to ionisation head **275** and from there, via branch **B28**, to ionisation head **229** (see **Fig.17B**). From head **229**, the gas flows through non-directed cathode ray tube **227** to high-frequency discharger **225**. The high frequency discharger **225**, with heating element, discharges, separates or completely neutralises the charge of any radioactive and/or cosmic particles that are in the helium atom in addition to the protons, neutrons and electrons.

The gas exits discharger **225** via branch **B26** and passes to high-frequency discharger **285**. The high frequency discharger **285**, without heating element, disturbs the frequency of oscillation which binds the gas atoms together. This prepares the helium atoms so that the electrons can more easily be split from the nucleus during the excitation and ignition process in the engine. Discharger **285** includes a phosphorus screen or deposit (similar to the coating on a cathode ray tube) which makes discharges in the tube visible. From discharger **285**, the helium passes through directed cathode ray tube **265** and focused x-ray tube **263**. Directed cathode ray tube **265** produces cathode rays which oscillate back and forth longitudinally underneath and along the gas carrying tube. After that, the helium passes successively through branch **B21**, ionisation head **221**, branch **B23**, twin parallel magnetic coil **266**, and branch **B25** into mixing chamber **261**. Helium flows slowly into and through apparatus **201**. The helium atoms become ionised as a result of excitation by magnetic force, high frequency vibrations and charge acquired from the ionisation heads. When sufficient helium has entered the apparatus, the ionisation energy (which is approximately 36% of the total) is totally absorbed. A spectroscopic flash of light in the mixing

chamber signals that the precise, proper quantity of helium has been allowed to enter. The entry of helium is then immediately halted by the closing of valve **V3**.

The next step in preparing the fuel is to add neon to the mixture. The potential on the relevant ionisation heads, particularly head **241** (see **Fig.17C**), is raised by the addition of approximately 26% which results in a total of approximately 62% of the total calculated potential and valve **V31** is opened, thereby allowing neon to slowly enter the mixer via port **245**. This gas passes through branch **B36**, ionisation head **241**, and branch **B35** directly into the mixing chamber. Since the previously admitted helium is fully charged, the neon absorbs all of the increased ionisation potential. As soon as the neon acquires the additional charge, a spectroscopic flash of light occurs and the operator closes valve **V31**.

In the same manner, the potential on the ionisation heads is increased by the addition of approximately 17% for a total of approximately 79% of the total calculated potential and then valve **V30** is opened to admit argon into the mixer via port **243**. This gas passes through branch **B34**, ionisation head **239**, and branch **B33** into mixing chamber **261**. Again, when the proper amount of argon has been admitted, it emits a spectroscopic flash of light and the operator closes valve **V30**. Next, the potential on the ionisation heads is increased by the addition of approximately 13% to result in a total of approximately 92% of the total calculated potential and valve **V58** (see **Fig.17D**) is opened to admit krypton into the system. The krypton gas passes through branch **B51**, ionisation head **271** and branch **B48** into chamber **261**. Upon the emission of a spectroscopic flash of light by the gas, the operator closes valve **V58**. Finally, the potential on the ionisation heads is increased by the addition of approximately 8% which brings the ionisation potential to the full 100% of the calculated ionisation voltage and valve **V56** is opened to admit xenon into the mixer via port **279**. This gas passes through branch **B50**, ionisation head **273** and branch **B47** to the mixing chamber. When the proper amount of gas has been admitted, a spectroscopic flash of light occurs signalling the operator to close valve **V56**. Note that there are two filter/absorber units, labelled **253** and **291**. Unit **253** is connected to the neon and argon inlet branches **B33** and **B35** while unit **291** is connected to the krypton and xenon inlet branches **B47** and **B48**. These two units absorb hydrogen residue and immobilise the water vapour created when the pump circulates the gases and generates vacuum states.

After all the gases are admitted in the desired proportions, all the valves are closed. (The mixture in the mixing chamber and in the adjacent tubing is at one atmosphere pressure at this time). Once this is done, the interval valves of the system are all opened (but the inlet and outlet valves remain closed) to allow the mixture to circulate throughout the tubing as follows: branch **B44**, magnetic coils **267** and **269**, ionisation head **240**, branch **B29**, ionisation head **231**, branch **B24**, ionisation head **219**, pump **217**, branches **B15** and **B39A**, ionisation gauge **255**, branches **B38** and **B42**, ionisation head **275**, branch **B28**, ionisation head **229**, non-directed cathode ray tube **227**, quadruple magnetic coil **272**, ionisation head **221**, branch **B23**, twin parallel magnetic coil **266**, branch **B25** and mixing chamber **261**. When this circuit is initially opened, the pressure of the mixture drops 40-50% because some of the tubing had previously been under vacuum. Pump **217** is then started to cause the gases to be slowly and evenly mixed.

Because of dead space in the tubing and the reaction time of the operator, it may occur that the proportions of the gases are not exactly those set forth above. This is remedied during the circulation step. As the gas flows through ionisation gauge **255**, excess gas is removed from the mixture so that the correct proportions are obtained. To do this the grid of gauge **255** is subjected to 100% ionisation energy and is heated to approximately 165 degrees F. This temperature of 165 degrees F is related to xenon's boiling point of -165 degrees F in magnitude but is opposite in sign. Xenon is the heaviest of the five inert gases in the mixture. As the gas mixture flows through ionisation gauge **255**, the gas atoms that are in excess of their prescribed percentages are burned out of the mixture and their charge is acquired by the remaining gas atoms from the grid of the ionisation gauge. Because the gases are under a partial vacuum, the ionisation gauge is able to adjust the gas percentages very precisely. (Note: The steps described in the last two paragraphs are repeated if the finished gases are rejected in the final quality control step described below).

The next step involves purifying the mixture so that only the five inert gases remain, absorbing any free electrons and regulating the electrical charge in the mixture. To do this, the circuit consisting of the following components is opened: Branch **B44**, magnetic coil **267**, magnetic coil **269**, ionisation head **240**, branch **B29**, ionisation head **231**, branch **B24**, ionisation head **219**, pump **217**, branches **B15** and **B39**, magnetic coil **287** (see **Fig.17D**) polariser **289**, branch **B17**, ionising and filtering unit **215**, branches **B16**, **B42**, and **B41**, x-ray tube **263**, branch **B21**, ionisation head **221**, branch **B23**, magnetic coil **266**, branch **B25**, and mixing chamber **261**. The gases should complete this circuit at least three times.

The last step required to prepare the mixture for bottling is polarisation of the argon. The circuit required to do this consists of the following components: mixing chamber **261**, branch **B44**, magnetic coil **267**, magnetic coil **269**, ionisation head **240**, cathode ray tube **265**, branch **B40**, tubing coil **257**, branches **B49** and **B30**, ionisation head **231**, branch **B24**, ionisation head **219**, pump **217**, branches **B15** and **B39**, twin parallel magnetic coil **287** (see

Fig.17D), polariser **289**, branch **B17**, ionising and filtering unit **215**, branches **B16**, **B42** and **B20**, ionisation head **229**, cathode ray tube **227**, magnetic coil **237**, ionisation head **221**, branch **B23** and magnetic coil **266**. This too is repeated at least three times. The key to the polarisation of argon is polariser **289** and twin parallel magnetic coil **287** that encircles it. Polariser **289** is a glass bottle which is filled with finely powdered soft iron which can be easily magnetised. The filled bottle is, in effect, the iron core of the coils. The iron particles align themselves with the magnetic lines of force, which lines radiate from the centre toward the north and south poles. The ionised gas mixture is forced through the magnetised iron powder by means of pump pressure and vacuum, thereby polarising the argon gas. Filters **293** and **295** are disposed as shown in order to filter metallic particles out of the gas.

The mixture is now double-checked by means of spark chamber **251** at atmospheric pressure since the fusion reaction in the engine is started at one atmosphere. Because the gases in mixing apparatus **201** are at a partial vacuum, sufficient gases must be pumped into spark chamber **251** to attain atmospheric pressure. To do this valves **V33**, **V36** and **V40A** are closed and circulating pump **217** pumps the gases in the mixing apparatus via branches **B15** and **B39A**, through check valve **V39A** into spark chamber **251** until the vacuum and pressure gauge **242** indicates that the gases within spark chamber **251** are at atmospheric pressure. Valve **V34** is then closed. The spark chamber is similar to a cloud chamber. Six or more high capacity brass capacitor plates are spaced 1/8" to 1/4" apart in the chamber. A small plastic container holds the thorium 232. One side of the chamber is equipped with a thick glass window through which sparks in the chamber may be observed. A potential is placed on the brass plates in the chamber and the current flowing between the plates is measured. If this current exactly corresponds to the ionisation current, the mixture is acceptable. A difference of greater than 5% is not acceptable. A lesser difference can be corrected by recirculating the gas in the mixer and particularly through ionisation gauge **255** as previously described in the circulation step. A second test is then given the gases that pass the first test. A calculated high frequency current is gradually imposed on the spark chamber capacitor plates. This excitation causes neutrons to be emitted from the thorium 232 which, if the mixture is satisfactory, can be easily seen as a thin thread of light in the chamber. If the mixture is not satisfactory, light discharges cannot be seen and the high frequency circuit will short out and turn off before the desired frequency is reached.

To bottle the mixture, valve **V33** is opened and valves **V36** and **V40** are closed. During bottling polariser **289**, twin parallel magnetic coil **287**, ionisation unit **215** and ion gauge **255** are electrically energised (all electrical circuits are previously de-energised) to improve the stability of the mixture. The prepared gases are withdrawn from the mixing apparatus via branches **B24** and **B16**, ionisation unit **215**, branch **B17**, filters **293** and **295**, polariser **289**, twin parallel magnetic coil **287**, branch **B39**, ion gauge **255**, check valve **V39A**, branch **B38** and spark chamber **251**. If desired, after bottling the mixer may be exhausted by opening valves **V12**, **V13**, **V14**, **V23**, **V24**, **V29**, **V32**, **V57** and **V59**. Of course, one can also automate the fuel preparation process to be continuous so that it would never be necessary to exhaust the gas.

In operation of mixing apparatus **201**, certain operational factors must be considered. For one, no electrical devices can be on without the pump being in operation because an electrical device that is on can damage adjacent gas that is not circulating. For another, it should be noted that directed cathode ray tube **265**, non-directed cathode ray tube **227** and focused x-ray tube **263** serve different functions at different points in the mixing process. In one mode, they provide hot cathode radiation, which can occur only in a vacuum. When gases are flowing through these devices, they provide a cold cathode discharge. For example, during argon polarisation and the circulation step, focused x-ray tube **263** is under vacuum and affects the gases flowing through ionisation head **240** by way of hot cathode radiation. During the introduction of the different gases into mixing apparatus **201** and during the recirculation step, the gases are flowing through focused x-ray tube **263**, which affects the gases by way of a cold cathode discharge.

It is preferred that each switchable electrical component in mixing apparatus **201** be wired into a separate circuit despite the fact that one of the poles of each could be commonly wired. In a common ground circuit if one device is turned on, all of the other units may also turn on because the gases in the device are conductive. In addition, if one unit on a common circuit were energised with high frequency current, the others would also be affected. In the same vein, the high frequency current cannot be used when the cathode ray tubes, the x-ray tubes or the dischargers are heated and under vacuum because the heater filaments will burn out.

Finally, the current source, the variable rectifiers and the electrical measuring instruments must be located more than ten feet from mixing apparatus **201** because the high frequency current is harmful to the rectifiers, causing them to burn out or short out.

It is hoped that a brief summary of the concepts used by the inventor in developing the above invention will be helpful to the reader, it being understood that this summary is in no way intended to limit the claims which follow or to affect their validity. The first concept is that of using an inert gas mixture at approximately one atmosphere at TDC (at ignition) as a fuel in a thermonuclear energy production process. The second concept is the layering of

the various inert gases, which layering is designed to confine the input energy in the innermost layers during pre-excitement and ignition, to provide thermal insulation for the container walls during and after ignition, to transmit power resulting from the ignition through the layers in turn to the piston, to absorb the pressure generated during ignition to protect the cylinder walls, and to provide an orderly, predictable positioning of the argon layer during the BDC to TDC portion of the engine cycle. The third concept of this invention involves utilising electric current produced in one cylinder of a pair to perform functions in the other cylinder of that pair. This concept includes the sub-concepts of generating electric current by atomic recombination and of electric generation in place resulting from the rotation of layered inert gases within each cylinder because of the changed polarity of the encircling coils at BDC, from judicious placement of coils which produce magnetic field lines which are cut by a near perfect conductor (polarised argon), and from movement of said near perfect conductor through the magnetic field.

The fourth and fifth concepts of this invention are the transformation of rapid, intense, but short duration thermonuclear reactions into pressure that is transmitted from inert gas to inert gas until it creates linear kinetic energy at the piston, which energy is converted into rotary kinetic energy by a crankshaft, and the use of a shaft-driven generator to provide power to spaced field coils during the BDC to TDC portion of the cycle of each cylinder.

The sixth concept concerns adequate pre-excitement of the inert gas fuel and more particularly involves the sub-concepts of pre-exciting the fuel in the mixing process, of manipulation of the currents in the coils surrounding each cylinder, of discharging the capacitors surrounding each cylinder at predetermined times in the cycles, of causing a stream of electrical particles to flow between electrodes and a conductive discharge point on the piston, of emitting alpha, beta and gamma rays from an anode and a cathode containing low level radioactive material to the piston's discharge point, of accelerating the alpha, beta and gamma rays by the application of a high-voltage field, and of situating capacitor plates 90 degrees from the anode and cathode to slow and reflect neutrons generated during ignition. The seventh concept involves the provision of a minute, pellet-type fission ignition, the heat from which causes a minute fusion as the result of the ignition chamber shape and arrangement, as a result of the collision of the alpha, beta and gamma rays and the electrical particles at a focal point in conjunction with the discharge of the capacitors that surround the cylinder through the electrodes, and as a result of increasing the magnetic field in the direction of the movement of each piston.

Robert Britt's Inert Gas Engine

US Patent 3,977,191

31st August 1976

Inventor: Robert G. Britt

ATOMIC EXPANSION REFLEX OPTICS POWER SOURCE (AEROPS) ENGINE

ABSTRACT

An engine is provided which will greatly reduce atmospheric pollution and noise by providing a sealed system engine power source which has no exhaust nor intake ports. The engine includes a spherical hollow pressure chamber which is provided with a reflecting mirror surface. A noble gas mixture within the chamber is energised by electrodes and work is derived from the expansion of the gas mixture against a piston.

SUMMARY OF THE INVENTION

An atomic expansion reflex optics power source (AEROPS) engine, having a central crankshaft surrounded by a crankcase. The crankcase has a number of cylinders and a number of pistons located within the cylinders. The pistons are connected to the crankshaft by a number of connecting rods. As the crankshaft turns, the pistons move in a reciprocating motion within the cylinders. An assembly consisting of a number of hollow spherical pressure chambers, having a number of electrodes and hollow tubes, with air-cooling fins, is mounted on the top of each cylinder. The necessary gaskets are provided as needed to seal the complete engine assemblies from atmospheric pressure. A means is provided to charge the hollow spherical pressure chamber assembly and the engine crankcase with noble gas mixtures through a series of valves and tubes. A source of medium-voltage pulses is applied to two of the electrodes extending into each of the hollow spherical pressure chambers.

When a source of high-voltage pulses is applied from an electrical rotary distributor switch to other electrodes extending into each of the hollow spherical pressure chambers in a continuous firing order, electrical discharges take place periodically in the various hollow spherical pressure chambers. When the electrical discharges take place, high energy photons are released on many different electromagnetic frequencies. The photons strike the atoms of the various mixed gases, e.g., xenon, krypton, helium and mercury, at different electromagnetic frequencies to which each is selectively sensitive, and the atoms become excited. The first photons emitted are reflected back into the mass of excited atoms by a reflecting mirror surface on the inside wall of any particular hollow spherical pressure chamber, and this triggers more photons to be released by these atoms. They are reflected likewise and strike other atoms into excitation and photon energy release. The electrons orbiting around the protons of each excited atom in any hollow spherical pressure chamber increase in speed and expand outward from centre via centrifugal force causing the atoms to enlarge in size. Consequently, a pressure wave is developed, the gases expand and the pressure of the gas increases.

As the gases expand, the increased pressure is applied to the top of the pistons in the various cylinders fired selectively by the electrical distributor. The force periodically applied to the pistons is transmitted to the connecting rods which turn the crankshaft to produce rotary power. Throttle control valves and connecting tubes form a bypass between opposing hollow spherical pressure chambers of each engine section thereby providing a means of controlling engine speed and power. The means whereby the excited atoms are returned to normal minimum energy ground-state and minimum pressure level, is provided by disrupting the electrical discharge between the medium-voltage electrodes, by cooling the atoms as they pass through a heat transfer assembly, and by the increase in the volume area above the pistons at the bottom of their power stroke. The AEROPS engine as described above provides a sealed unit power source which has no atmospheric air intake nor exhaust emission. The AEROPS engine is therefore pollution free.

BRIEF OBJECTIVE OF THE INVENTION

This invention relates to the development of an atomic expansion reflex optics power source (AEROPS) engine, having the advantages of greater safety, economy and efficiency over those disclosed in the prior art. The principal object of this invention is to provide a new engine power technology which will greatly reduce atmospheric pollution and noise, by providing a sealed system engine power source which has no exhaust nor intake ports.

Engine power is provided by expanding the atoms of various noble gas mixtures. The pressure of the gases increases periodically to drive the pistons and crankshaft in the engine to produce safe rotary power. The objects and other advantages of this invention will become better understood to those skilled in the art when viewed in light of the accompanying drawings.

BRIEF DESCRIPTION OF THE DRAWINGS

Fig.1 is an elevational view of the hollow spherical pressure chamber assembly, including sources of gas mixtures and electrical supply:

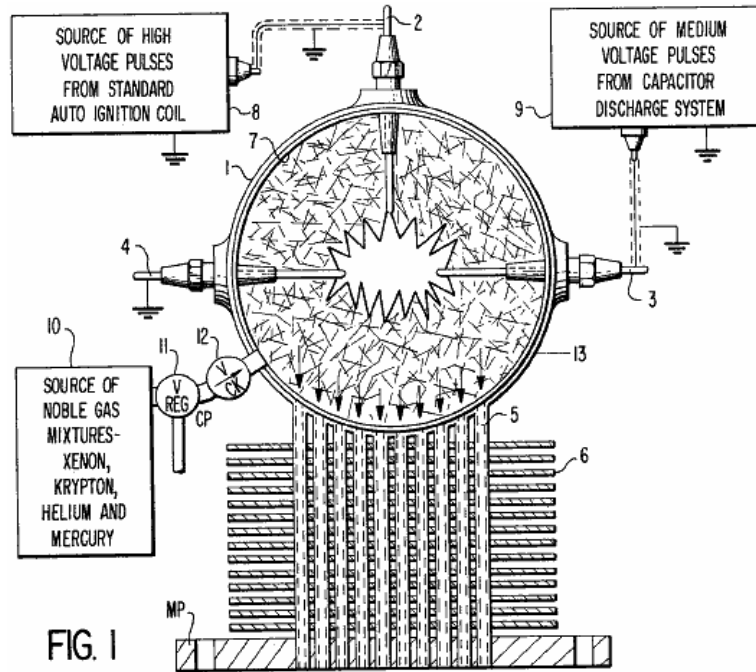

FIG. 1

Fig.2 is an elevational view of the primary engine power stroke:

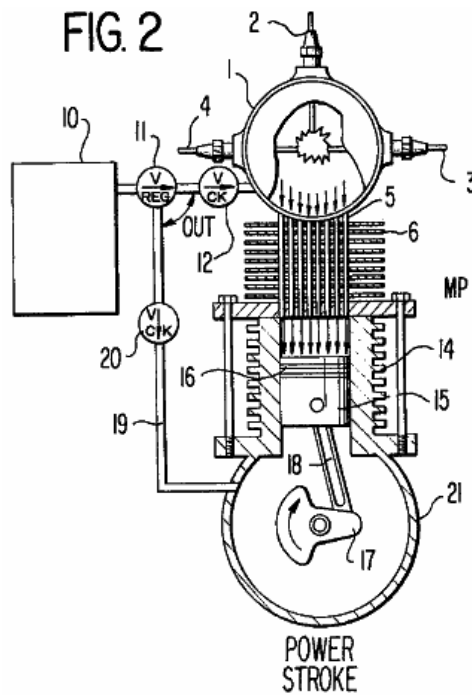

FIG. 2

Fig.3 is an elevational view of the primary engine compression stroke:

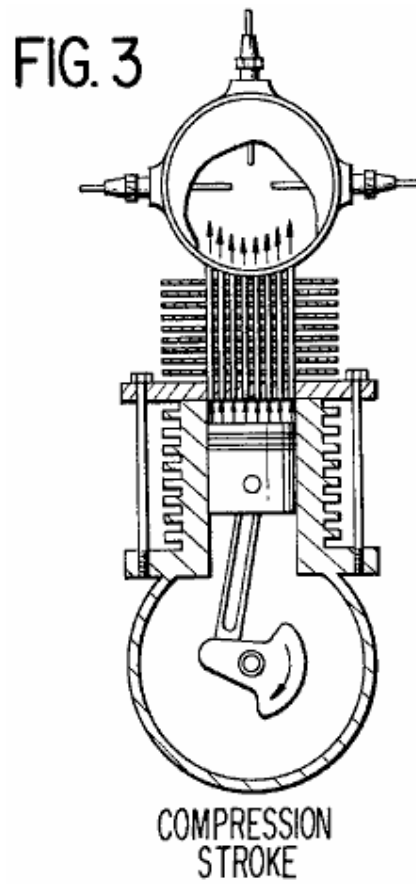

Fig.4 is a rear elevational view of a six cylinder AEROPS engine:

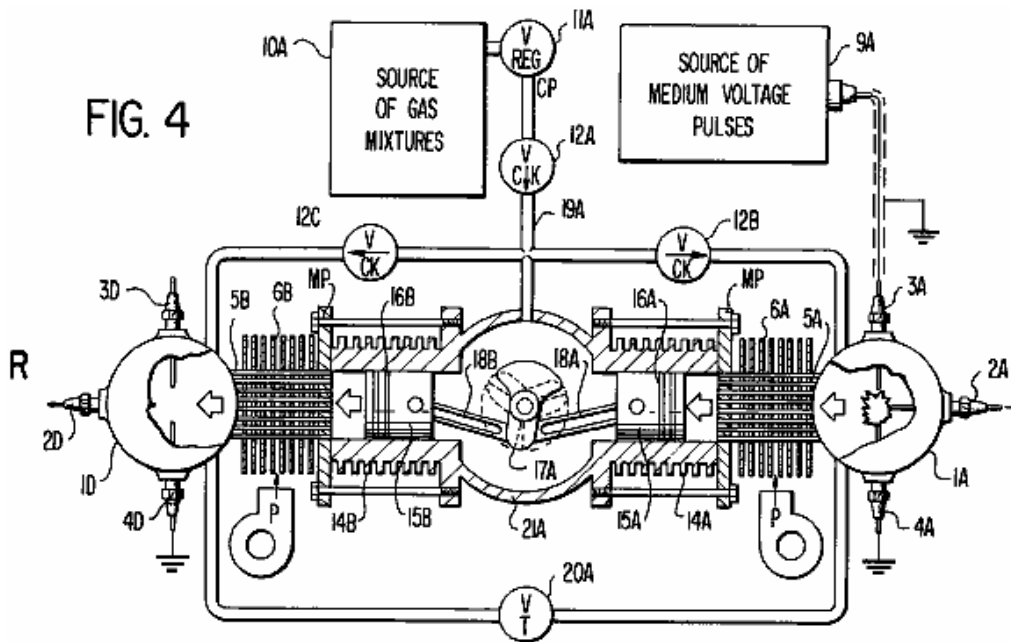

Fig.5 is a top view of the six cylinder AEROPS engine:

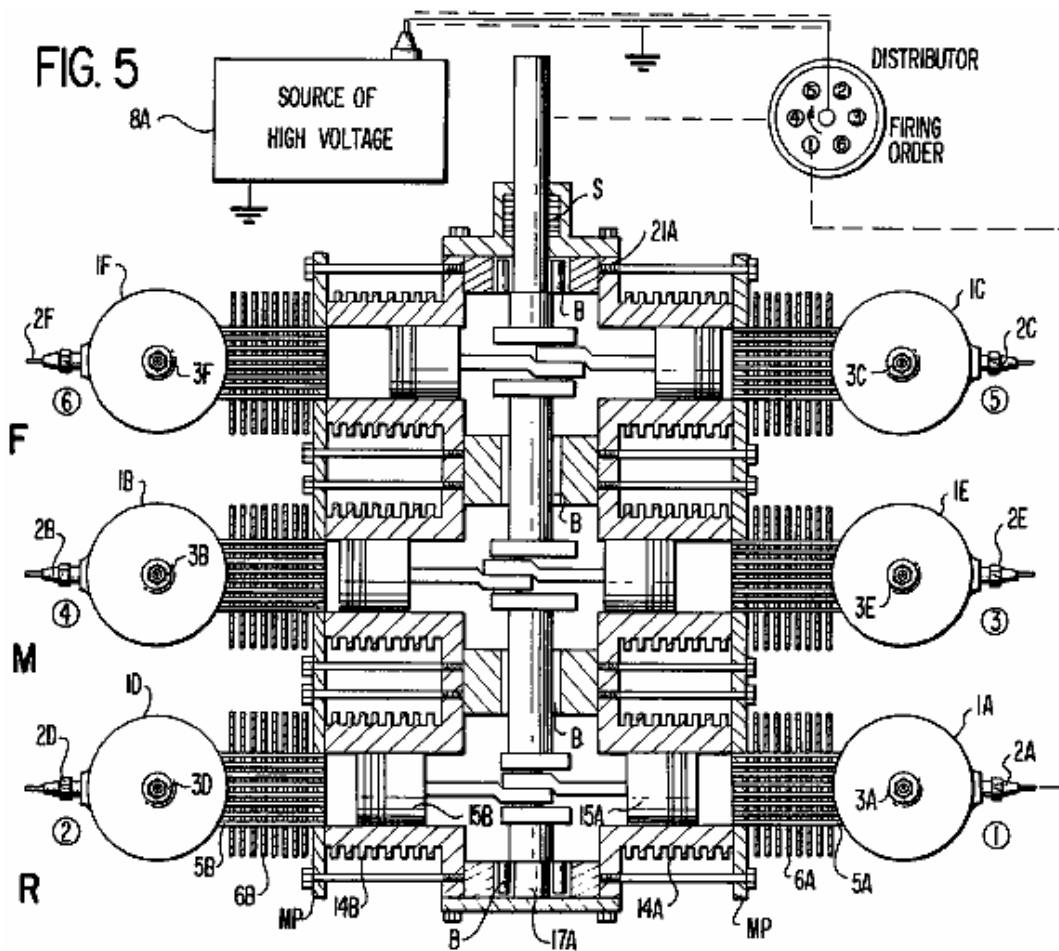

Fig.6 is an electrical schematic of the source of medium-voltage:

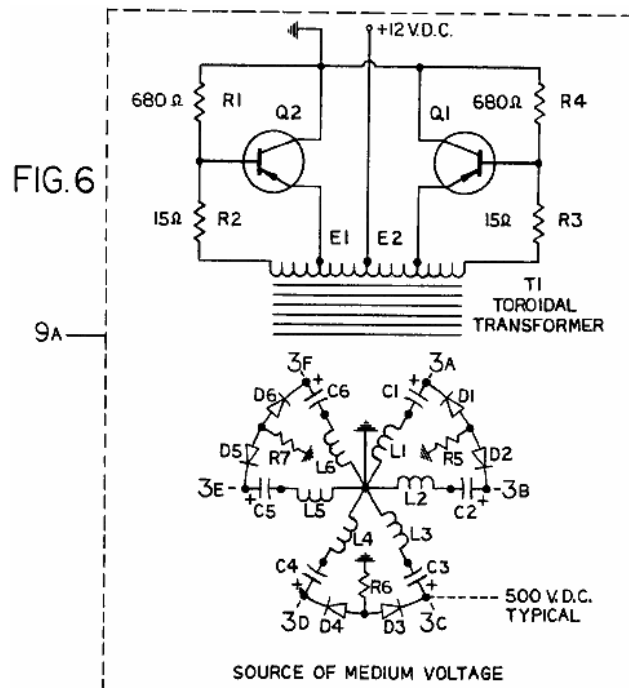
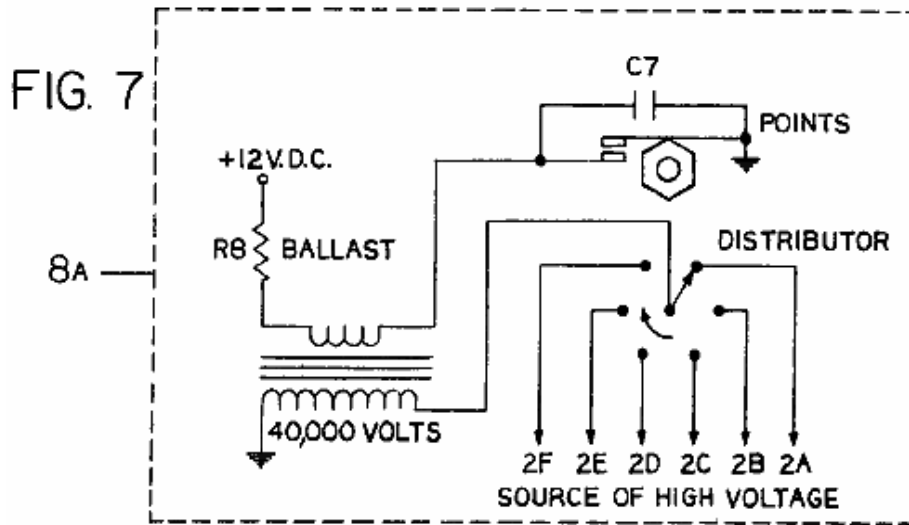
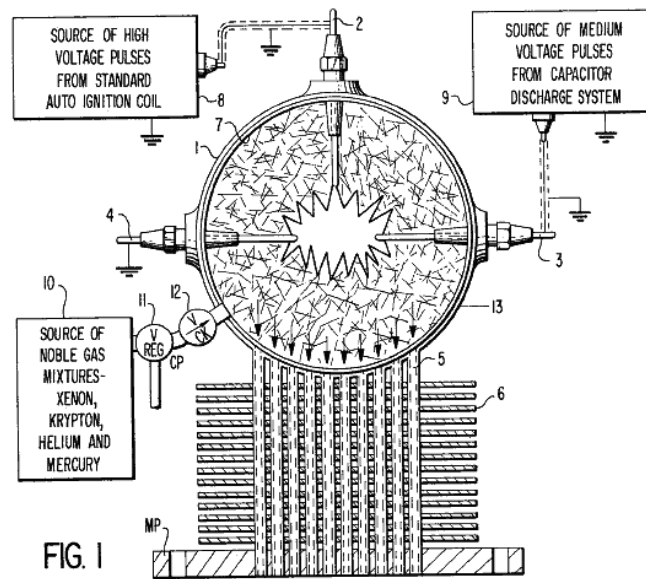

Fig.7 is an electrical schematic of the source of high-voltage:



DETAILED DESCRIPTION



Referring to **Fig.1** of the drawings, the AEROPS engine comprises a hollow spherical pressure chamber **1** having an insulated high-voltage electrode **2** mounted on the top, an insulated medium-voltage electrode **3** mounted on the right, and an insulated common ground electrode **4** mounted on the left, as shown in this particular view. Electrodes **2**, **3** and **4** extend through the wall of the hollow spherical pressure chamber **1** and each electrode forms a pressure seal. A plurality of hollow tubes **5** arranged in a cylindrical pattern extend through the wall of the hollow spherical pressure chamber **1**, and each hollow tube is welded to the pressure chamber to form a pressure seal. The opposite ends of hollow tubes **5** extend through the mounting plate **MP** and are welded likewise to form a pressure seal. A plurality of heat transfer fins **6** are welded at intervals along the length of said hollow tubes **5**. A bright reflecting mirror surface **7** is provided on the inner wall of the hollow spherical pressure chamber **1**. A source of high-voltage **8** is periodically connected to the insulated high-voltage electrodes **2** and **4**. A source of medium-voltage **9** from a discharge capacitor is connected to the insulated medium-voltage electrodes **3** and **4**. A source of noble gas mixtures **10**, e.g., xenon, krypton, helium and mercury is applied under pressure into the hollow spherical pressure chamber **1** through pressure regulator valve **11** and check valve **12**.

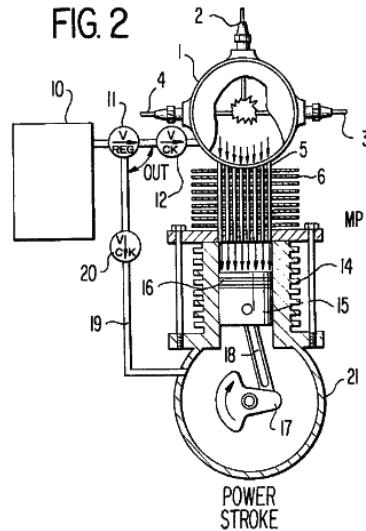

Referring now to **Fig.2** of the drawings, the complete assembly **13** shown in **Fig.1** is mounted on the top of the cylinder **14** via mounting plate **MP**. The necessary gaskets or other means are provided to seal the engine and prevent loss of gases into the atmosphere. The piston **15** located within cylinder **14** has several rings **16** which seal against the inner wall of the cylinder. The piston **15** is connected to the crankshaft **17** by connecting rod **18**. The source of noble gas mixtures **10** is applied under pressure into the crankcase **21** through pressure regulator valve **11**, check valve **12** and capillary tube **19**. The piston **15** is now balanced between equal gas pressures. Assuming that the engine is running and the piston **15** is just passing Top-Dead-Centre (TDC), a source of medium-voltage from a capacitor discharge system **9** (**Fig.6**, a single typical capacitor section) is applied to electrodes **3** and **4**. A source of high-voltage pulses from a standard ignition coil **8** (such as shown in **Fig.7**) is applied to electrodes **2** and **4** and the gases within the hollow spherical pressure chamber **1** are ionised and made electrically conductive. An electrical discharge takes place between electrodes **3** and **4** through the gases in the hollow spherical pressure chamber **1**.

The electrical discharge releases high energy photons on many different electromagnetic frequencies. The photons strike the atoms of the various gases, e.g., xenon, krypton, helium and mercury at different electromagnetic frequencies to which each atom is selectively sensitive and the atoms of each gas become excited. The first photons emitted are reflected back into the mass of excited atoms by the reflecting mirror surface **7**. This triggers more photons to be released by these atoms, and they are reflected likewise from the mirror surface **7** and strike other atoms into excitation and more photons are released as the chain reaction progresses. The electrons orbiting around the protons of each excited atom increase in speed and expand outward in a new orbital pattern due to an increase in centrifugal force. Consequently, a pressure wave is developed in the gases as the atoms expand and the overall pressure of the gases within the hollow spherical pressure chamber **1** increases. As the gases expand they pass through the hollow tubes **5** and apply pressure on the top of piston **15**. The pressure pushes the piston **15** and the force and motion of the piston is transmitted through the connecting rod **18** to the crankshaft **17** rotating it in a clockwise direction. At this point of operation, the power stroke is completed and the capacitor in the medium-voltage capacitor discharge system **9** is discharged. The excited atoms return to normal ground state and the gases return to normal pressure level. The capacitor in the medium-voltage capacitor discharge system **9** is recharged during the time period between (TDC) power strokes.

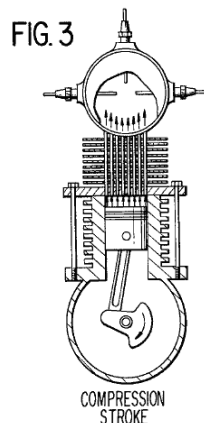

Referring now to **Fig.3** of the drawings, the compression stroke of the engine is shown. In this engine cycle the gases above the piston are forced back into the hollow spherical pressure chamber through the tubes of the heat transfer assembly. The gases are cooled as the heat is conducted into the fins of the heat transfer assembly and carried away by an air blast passing through the fins. An example is shown in **Fig.4**, the centrifugal air pump **P** providing an air blast upon like fins.

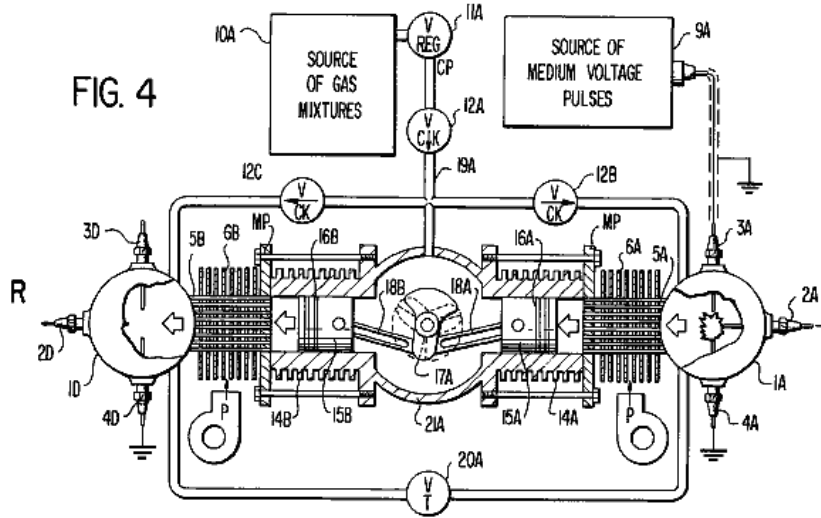

Some of the basic elements of the invention as set forth in **Fig.1**, **Fig.2**, and **Fig.3** are now shown in **Fig.4** and **Fig.5** which show complete details of a six-cylinder horizontally-opposed AEROPS engine.

Referring now to **Fig.4** and **Fig.5** of the drawings. **Fig.4** is a view of the rear section of the engine showing the crankshaft, centre axis and two of the horizontally-opposed cylinders. In as much as the rear **R**, middle **M** and front **F** sections of the engine possess identical features, only the rear **R** engine section will be elaborated upon in detail in order to prevent repetition and in the interest of simplification. The crankshaft **17A** consists of three cranks spaced 120 degrees apart in a 360 degree circle as shown. Both connecting rods **18A** and **18B** are connected to the same crank. Their opposite ends connect to pistons **15A** and **15B**, located in cylinders **14A** and **14B** respectively. Each piston has pressure sealing rings **16A** and **16B**. The hollow spherical pressure chamber assemblies consisting of **1A** and **1D** are mounted on cylinders **14A** and **14B** via mounting plates **MP**. The necessary gaskets are provided as needed to seal the complete engine assemblies from atmospheric pressure.

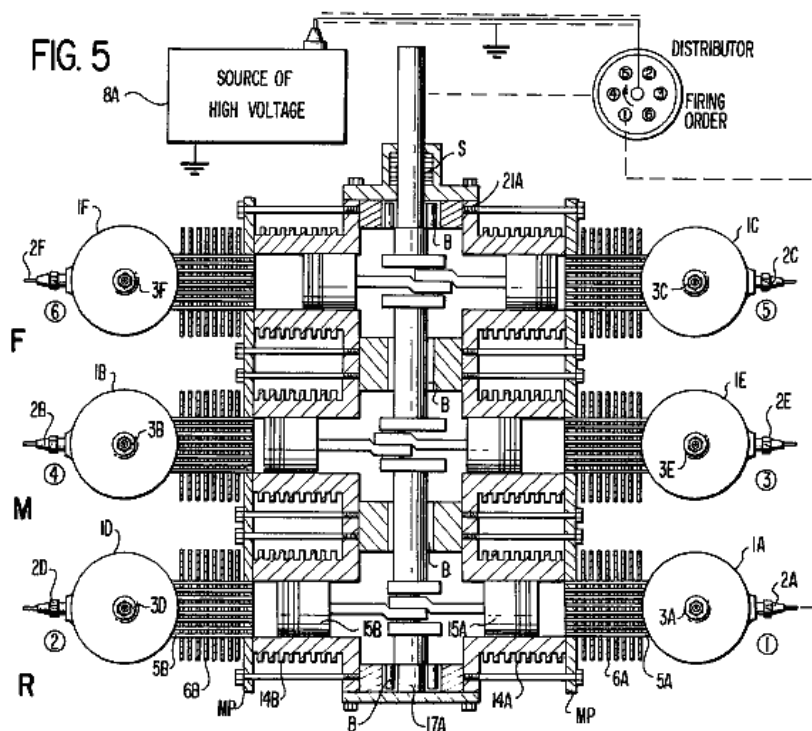

The source of gas mixtures **10A** is applied under pressure to pressure regulator valve **11A** and flows through check valve **12A**, through check valve **12B** to the hollow spherical pressure chamber **1A**, and through check valve

12C to the hollow spherical pressure chamber 1D. The gas flow network consisting of capillary tubes below point 19A represents the flow of gases to the rear section R of the engine. The middle section M and the front section F both have gas flow networks identical to that consisting of capillary tubes below point 19A, while the gas flow network above is common to all engine sections. Throttle valve 20A and the connecting tubing form a variable bypass between hollow spherical pressure chambers 1A and 1D to control engine speed and power. Engine sections R, M and F each have this bypass throttle network. The three throttle valves have their control shafts ganged together. A source of medium-voltage pulses 9A is connected to medium-voltage electrodes 3A and 3D. In one particular embodiment the medium-voltage is 500 volts. A source of high-voltage pulses 8A is connected to electrode 2A through the distributor as shown. Electrode 4A is connected to common ground. Centrifugal air pumps P force air through heat transfer fins 6A and 6B to cool the gases flowing in the tubes 5A and 5B.

Fig.5 is a top view of the AEROPS engine showing the six cylinders and crankshaft arrangement consisting of the rear R, middle M and front F sections. The crankshaft 17A is mounted on bearings B, and a multiple shaft seal S is provided as well as the necessary seals at other points to prevent loss of gases into the atmosphere. The hollow spherical pressure chambers 1A, 1B, 1C, 1D, 1E and 1F are shown in detail with high-voltage electrodes 2A, 2B, 2C, 2D, 2E, 2F and medium-voltage electrodes 3A, 3B, 3C, 3E and 3F. The common ground electrodes 4A, 4B, 4C, 4D, 4E, 4F are not shown in Fig.5 but are typical of the common ground electrodes 4A and 4D shown in Fig.4. It should be noted that the cranks on crankshaft 17A are so arranged to provide directly opposing cylinders rather than a conventional staggered cylinder design.

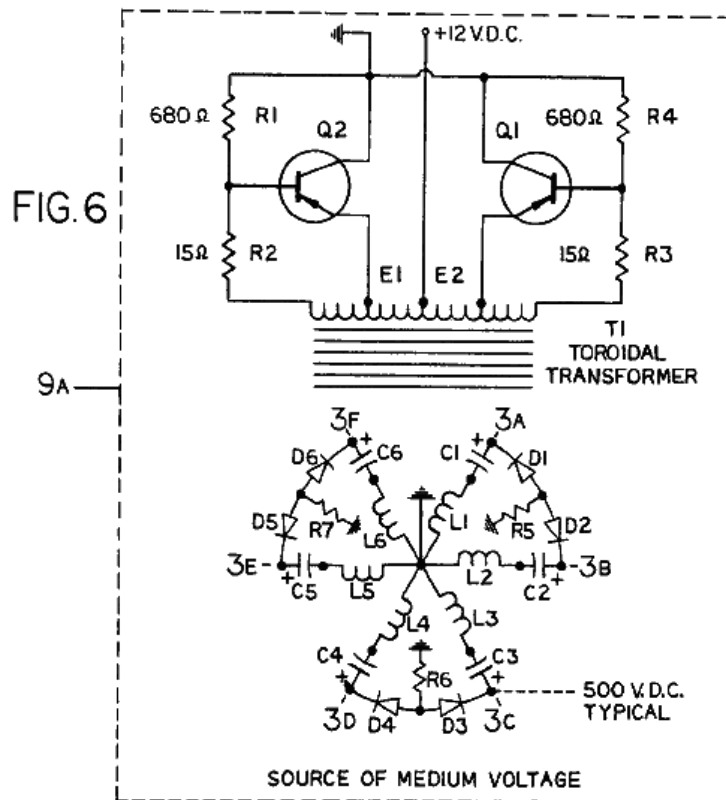
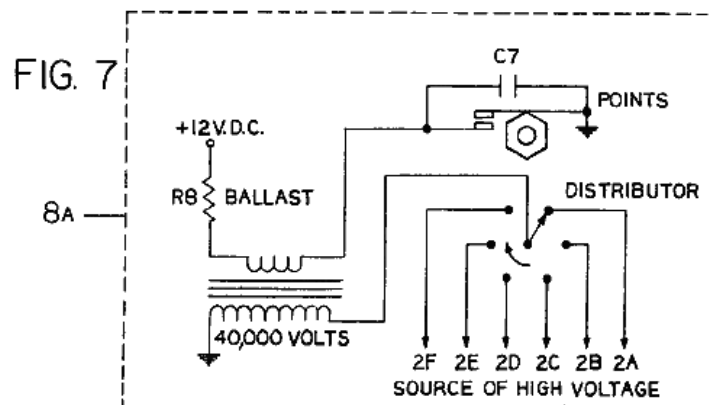

Fig.6 is an electrical schematic of the source of medium-voltage 9A. The complete operation of the converter is explained as follows: The battery voltage 12 VDC is applied to transformer T1, which causes currents to pass through resistors R1, R2, R3 and R4. Since it is not possible for these two paths to be exactly equal in resistance, one-half of the primary winding of T1 will have a somewhat higher current flow. Assuming that the current through the upper half of the primary winding is slightly higher than the current through the lower half, the voltages developed in the two feedback windings (the ends connected to R3 and R2) tend to turn transistor Q2 on and transistor Q1 off. The increased conduction of Q2 causes additional current to flow through the lower half of the transformer primary winding. The increase in current induces voltages in the feedback windings which further drives Q2 into conduction and Q1 into cut-off, simultaneously transferring energy to the secondary of T1. When the current through the lower half of the primary winding of T1 reaches a point where it can no longer increase due to the resistance of the primary circuit and saturation of the transformer core, the signal applied to the transistor from the feedback winding drops to zero, thereby turning Q2 off. The current in this portion of the primary winding drops immediately, causing a collapse of the field about the windings of T1. This collapse in field flux, cutting across all of the windings in the transformer, develops voltages in the transformer windings that are opposite in polarity to the voltages developed by the original field. This new voltage now drives Q2 into cut-off

and drives **Q1** into conduction. The collapsing field simultaneously delivers power to the secondary windings **L1**, **L2**, **L3**, **L4**, **L5** and **L6**. The output voltage of each winding is connected through resistors **R5**, **R6** and **R7** and diode rectifiers **D1**, **D2**, **D3**, **D4**, **D5** and **D6**, respectively, whereby capacitors **C1**, **C2**, **C3**, **C4**, **C5** and **C6** are charged with a medium-voltage potential of the polarity shown. The output voltage is made available at points **3A**, **3B**, **3C**, **3D**, **3E** and **3F** which are connected to the respective medium-voltage electrodes on the engine shown in **Fig.4** and **Fig.5**.



Referring now to **Fig.7** of the drawings, a conventional "Kettering" ignition system provides a source of high-voltage pulses **8A** of approximately 40,000 volts to a distributor, which provides selective voltage output at **2A**, **2B**, **2C**, **2D**, **2E** and **2F**, which are connected to the respective high-voltage electrodes on the engine shown in **Fig.4** and **Fig.5**. The distributor is driven by the engine crankshaft **17A** (**Fig.5**) at a one to one mechanical gear ratio.

Referring again to **Fig.4** and **Fig.5** of the drawings, the operation of the engine is as follows: Assuming that a source of noble gas mixtures, e.g., xenon, krypton, helium and mercury is applied under pressure to the hollow spherical pressure chambers **1A**, **1B**, **1C**, **1D**, **1E** and **1F** and internally to the crankcase **21A** through pressure regulator valve **11A** and check valves **12A**, **12B** and **12C**; and the source of medium-voltage **9A** is applied to electrodes **3A**, **3B**, **3C**, **3D**, **3E** and **3F**; and a source of high-voltage pulse **8A** is applied to electrode **2A** through the timing distributor, the gas mixtures in the hollow spherical pressure chamber **1A** is ionised and an electrical discharge occurs immediately between electrodes **3A** and **4A**.

High-energy photons are released on many different electromagnetic frequencies. The photons strike the atoms of the various gases, e.g., xenon, krypton, helium and mercury at different electromagnetic frequencies to which each is particularly sensitive and the atoms of each gas become excited. The first photons emitted are reflected back into the mass of excited atoms by the internal reflecting mirror surface on the inside wall of the hollow spherical pressure chamber **1A**. This triggers more photons to be released by these atoms and they are reflected likewise from the mirror surface and strike other atoms into excitation and more photons are released as the chain reaction progresses. The electrons orbiting around the protons of each excited atom in the hollow spherical pressure chamber **1A** increase in speed and expand outward in a new orbital pattern due to an increase in centrifugal force. Consequently, a pressure wave is developed in the gases as the atoms expand and the overall pressure of the gases within the hollow spherical pressure chamber **1A** increases.

As the gases expand they pass through the hollow tubes **5A** applying pressure on the top of piston **15A**. The pressure applied to piston **15A** is transmitted through connecting rod **18A** to the crankshaft **17A** rotating it in a clockwise direction. As the crankshaft **17A** rotates it pushes piston **15B** via connecting rod **18B** in the direction of a compression stroke, forcing the gases on the top of the piston through hollow tubes **5B** into the hollow spherical pressure chamber **1D**. As the gases pass through the hollow tubes **5A** and **5B** the heat contained in the gases is conducted into the heat transfer fins **6A** and **6B**, where it is dissipated by a blast of air passing through said fins from the centrifugal air pumps **P**. At this point of operation the power stroke of piston **15A** is completed and the capacitor in the medium-voltage capacitor discharge system **9A** is discharged. The excited atoms return to normal ground state and the gases return to normal pressure level. The capacitor in the medium-voltage capacitor discharge system **9A** is recharged during the time period between the power strokes of piston **15A**.

The above power stroke cycle occurs exactly the same in the remaining cylinders as the high-voltage firing order progresses in respect to the position of the distributor switch. In as much as the AEROPS engine delivers six power strokes per single crankshaft revolution, the crankshaft drives the distributor rotor at a one to one shaft ratio. The complete high-voltage firing order is 1, 4, 5, 2, 3, 6, whereas, the high-voltage is applied to electrodes **2A**, **2B**, **2C**, **2D**, **2E** and **2F** respectively. A means of controlling engine speed and power is provided by a plurality of throttle control valves and connecting tubes which form a bypass between opposing hollow spherical pressure chambers of each engine section.

The AEROPS engine as described above provides a sealed unit power source which has no atmospheric air intake nor exhaust emission and is therefore pollution free.

Floyd Sweet

Recently, some additional information on Floyd Sweet's device, has been released publicly by an associate of Floyd's who goes just by his first name of "Maurice" and who, having reached the age of seventy has decided that it is time to release this additional information.

Maurice says: After observing the comments made over the past year regarding the Sweet-VTA Energy Device, I decided to "come out of the woodwork" and explain what basically is NOT known regarding Floyd Sweet ("Sparky") and his energy device.

Keep in mind that I am 70 years old, quite computer illiterate, my background Being mainly Political Science (Graduate Degree); consulting with State Legislatures; Mental Health (former Executive Director of five clinics); and, acquiring Venture Capital for High Tech. Equipment (such as medical equipment) and various Projects. My story is very unusual and strange, but, nevertheless TRUE! At my age I have no one to impress with what I am about to tell you. My only interest is to correct error where possible and to make certain information known!

Remember, that I have never had any education in electronics. This was a real advantage for me because I did not have any electrical principles which I had to UN-LEARN in anything that Floyd told us. Unfortunately, one of my brothers who trained for 35 years in electronics was "blown away" when Floyd told him that "he needed to reverse the concepts which he was taught about the action of an electron and treat it like it was positive". Therefore, for Sparky's modelling, electrons were flowing and acting in the opposite direction to what was normally modelled by a trained physicist. See what I mean? The Dean of the School of Science of MIT that verified that Sparky had an MSEE degree and came third in his class of more than two hundred.

Hopefully sincere researchers will be able to obtain some useful information in what I attempt to explain in the future that will help them to duplicate what Floyd had. In this respect, one day after Floyd had repeatedly asked me: "What is this device Maurice?" and I repeatedly gave him the wrong answer, saying that it was an energy device, I finally realised that what was important to him was that he considered the device to be a TIME MACHINE - his emphasis was NOT on the energy. He told me never to forget that the most important thing was that the device was a "Time Machine".

Maurice draws attention to the fact that Floyd Sweet graduated as an M.S.E.E. from the Massachusetts Institute of Technology in 1969 and his thesis "Dynamics of Magnetic Domains" is considered by the M.I.T. scientific community to be unparalleled in magnetic concepts. He received the coveted Dean's Award for his scientific research and his academic level in Electrical Engineering achievement ranks third in the history of the M.I.T. School of Science. He has an extraordinary talent in the area of Engineering Mathematics not to mention his concept of electromagnetic and related electrical phenomena and understanding of abstract intangibles needed to predict the unforeseen.

Maurice says: In about 1988 John, who my two brothers and I were involved with in the High Tech field realised that my brother, who was a Doctor (Doctor brother), was interested in negative energy devices for the treatment of the physical body (similar to Rife/Tesla Frequency Machines). John had formerly been employed at NASA with Floyd Sweet. John lived in California close to Floyd (Sherman Oaks).

My doctor brother and I were introduced to Floyd by John and we waited patiently for the time when we could see the VTA device. We saw it on the table at his house during various visits but it was not operating. Floyd was like many inventors who played games with you. Each time we would drive 13 hours to see him thinking we could see the device operating, but he would have some excuse for not turning it on, or he would just ignore the purpose of our visit.

On one visit, I looked over at Floyd and he was "showing off" his Barium Ferrite bar magnet. The magnet was approximately 1/2" thick, 7" long and 3" wide. He had a small piece of metal that was standing on the top of the magnet at a 45 degree angle. As I recall, he claimed that the 45 degree angle was needed in the treatment of the magnet so that it could capture Scalar waves. The magnets were mainly functioning as a "gate" for the Scalar waves. Additionally, if you placed a piece of thin "flexible" (ribbon type) metal flat on the top of the magnet, the middle of the "ribbon metal" would be "sucked down" flat at the middle of the magnet and both ends of the "ribbon metal" would be bowed-up at each end of the magnet. Also, I came to understand from another inventor that we introduced later on to Floyd that the "figure eight" design (flux flow?) on the top of the magnet played an important part in the functioning of the magnet - I don't really know about the concept and can't relay any additional information.

On another visit, Floyd demonstrated the flowing flux of the magnet. He had a TV monitor and he would place the magnet by the screen and you could see all the beautiful colours of the flux as it moved across the monitor screen. My electronics brother told me that Floyd had told him that he had a way of treating the magnet by calibrating the Scalar wave angle coming in using the TV monitor. A side note is that Floyd delighted in telling people, when they asked how he treated his magnets, they should get the magnets real hot first. This apparently "screwed up" the magnetism and he enjoyed doing this for some weird reason!

Finally, after 12 trips across the California Desert, Floyd agreed to show us the Device in operation. In his defence, Floyd did claim that on some earlier planned demonstrations that his magnets had been "pulverized" by artificial earthquakes coming up through Mexico. He designed some type of buffer in the Device that eliminated the problem, but, it was an on-going problem for quite a period of time. This reminds me now that I must digress because I need to tell you about the Government (or who?) involvement with us.

When we first started to visit Floyd, our phones were all "tapped" - I do not know by whom. My electronics brother worked full-time with the Air National Guard and his specialty was electronic Security, Crypto, etc. tied in with SAC bases in our area and the surrounding States. Additionally, he had set-up the "clean room" for the President of the United States when he visited our State. I mention this because even my electronics brother was doubtful in the beginning that we were all being monitored. On one occasion, my doctor brother had his complete prior telephone conversation played back to him when he answered the phone (twenty minutes later) - I think it was probably some type of "screw-up" by whoever was monitoring our phones. My biggest complaint was the consistent early morning 3am call and then a "hang-up" when you answered - for what reason I don't know other than for harassment purposes.

I give you the above information so that you can understand the seriousness of what we were involved with.

Floyd's Energy Device was mainly three things:

(1) It was a healing device - negative electricity - negative time. In theory, you could re-set the template in your DNA with this energy source and therefore cleanse the body of all impurities that your ancestors had acquired over time. Additionally, you could kill current disease (virus/bacteria) in the body by using the right frequencies, and this did not disturb any other body cells. This is why Floyd needed my doctor brother to help him arrive at the proper medical protocol for using his technology. Additionally, if you note in the Payroll Expenses attachment of this e-mail, a one-line item of expenditure is for AIDS-related materials in which Floyd and my doctor brother had a real interest. My doctor brother had an agreement with Floyd to build three medical interferometers which would all have a noble gas plasma inside them. I actually witnessed one of these devices in operation. At the end of the (approximately 20 inch long) tube-like structure you could feel a pulsing being emitted at the end of the tube on to whichever part of the body you wanted treated. My doctor brother had ordered two Interferometers from Floyd which were about 4 feet long.

(2) The VTA energy device is probably the world's worst weapon. Floyd claimed that like Nicola Tesla, you could cause "artificial earthquakes" - besides destroying buildings. As I understood from people in the intelligence world, which we de-briefed after we saw the device operate, three countries have what is called the "Tesla Cannon"; Russia, America and I never found out who the third country was. As mentioned earlier, this energy source is what disabled Floyd's VTA equipment over many months until he got his "buffer" built into his device. Further, this is why the Federal Government had such an interest in what we were doing with Floyd during the time we spent with him.

(3) The device was an Energy source for the home (could change negative energy to positive energy). It was also an energy source for the car and many other purposes. The cost of building one of these energy devices was only about US \$200.00 - incredible!

Description of the VTA device:

On the day that we finally got to see the device operating, my doctor brother and I had finally convinced my electronics brother to accompany us to Sherman Oaks, California to see the demonstration. My doctor brother and I had made ALL the preliminary trips to see Floyd minus our electronics brother because he was literally a "doubting Thomas", being heavily involved in the electronics field and full of Maxwell's Theories of electronics, etc. Yes, you could say that he was a traditional electronics person. But, for this reason, we needed my electronics brother to be our DEBUNKER in case the device was not what it was portrayed to be. We had one other witness "Gary", an associate of mine who was to bring in

the venture capital funding if the device proved to be as good as claimed.

The day when we witnessed the VTA device operating is a day which I shall never forget. To actually see a device working, which cost only \$200 dollars to make and which could create all the clean energy you would ever need, was "awesome". I know I have been "altered" ever since knowing that such a device existed. Now for a brief description of the Device:

These are not exact measurements but only approximations. The device was on what I believe to be "Plexi glass" (acrylic). Nothing was hidden. You could see everything, top and bottom through the plastic. The Plexi glass structure was approximately 18" square. We were allowed to pick-up the device and carry it around Floyd's living room so you could see that there were no other electrical connections to it.

On top of the Plexi glass case there were three toroidal coils wound with thin windings of varnished copper wire. There were two barium ferrite bar magnets (approx. 7"x 3"x 1/2"). Present was a volt meter which displayed 120v when the device was turned on. Also, there was an ampere meter which measured the electrical currents flowing when Floyd switched different things on-and-off during the demonstration. The items used for load demonstration included the burner part of the stove, a hair dryer, a fan, and five one-hundred watt globe lights. The fascinating thing to me about the light demo was that the lights had a glow like the overhead lights in your kitchen - a very soft, COOL appearance. Not the look of a traditional bright light bulb such as you have in your lamp on a traditional night stand.

I forgot to mention that the device was started by attaching a 9-volt battery which, I understand, started the magnetic flux in motion. Floyd would then connect the "pigtail" on the device and it would become just one circular energy unit.

As Floyd put more load on the device, the ambient temperature around the device (coils) would start to get lower. Additionally, depending on how much load you added, the device would start to lose some of its weight and you then had levitation beginning to take place. I should note at this point that on one meeting with Floyd, his wife Rose, used some expletives when telling how one day, Floyd kept adding more-and-more load to the device and he almost "brought down" the Apartment Complex he lived in at Sherman Oaks. He turned off the equipment, went out on his patio and pretended that it was a California Earthquake! His neighbours never did know what he had in his apartment. In this respect, I never did find out what the big piece of equipment was in his bedroom. It literally stretched from the ceiling to the floor. It was so heavy that the floor was bowed-in and sunken and that "big sucker" had a growling noise when it was on - I never did find out what it was. It was big like some kind of transformer.

The Rest of The Story:

You are probably wondering what the article on Ron Brandt is about. It's a long story, but after I moved Ron and his laboratory all the way from the mouth of Zion's National Park to "someplace" Oregon to hide him out - he was using "Tachyon Beams" with his medical equipment and after only a couple of minutes the "Black Helicopters" would show up - soooo at my doctor brother's request I moved Ron to Oregon. At the time I thought Ron was a "real flake" because when I helped him forward his mail from a small town in Southern Utah, he asked me how to spell the word "electric" so he could put in the full address of "Brandt Electric". Further, Ron said he was only here on this Earth until 2012 - It was now 1987-88 - and then he had to leave to go to another planet! I now wanted to shoot my doctor brother who got me into this whole moving-Ron thing! My doctor brother told me that Ron had to move fast because Ron had told him that an earthquake was coming in the next few days - Right!

Well, guess what happened a few days later? The largest earthquake in many years in that particular location took place and it even wiped out the hot springs at the Resorts along the Virgin River which runs through Zion's National Park and through the small town of Virgin where Ron lived. I since found out that Ron had invented earthquake equipment along with Philo T. Farnsworth's (Inventor of Television) grandson and six months ahead, they had actually predicted the previous great earthquake in California and their prediction was off by only six minutes! The Government is insisting that they want the equipment, so that is one of the reasons for everyone "hiding out".

Now, why am I giving you all this preliminary information regarding Ron Brandt? Well it seems that Ron has a Magnet Motor which weighs only 75 pounds and which can generate power equivalent to that of a 300 horsepower internal combustion engine. Also, the motor can be a retro-fit in any existing car without the need to design a whole new car. This is the connection I will explain later regarding Ron who could not even spell "electric" and Floyd who was placed 3rd in all the inventions to ever come out of MIT - All I can say is "WOW"!

EVENTS SURROUNDING FLOYD'S DEATH:

I will now leave it up to you to decide whether or not Floyd died of natural causes or was "taken out" by some person, group, or some Government.

In the summer of 1994, my doctor brother suddenly "passed out" at one of our Venture Capital meetings and was rushed to the hospital. After an MRI of his head, it was discovered that he had a brain tumour and it was of the worst kind (very fast growing). This seemed impossible as my doctor brother had always monitored his body daily as he did an occasional experiment on himself with certain medicines. By 11th November 1994, my doctor brother had died. He told us prior to death that "they" (whoever "they" were) had succeeded in placing the fastest growing cancer tumour into his brain - How? - I have no idea! I never did find out. What is important to the free-energy field was that my doctor brother was in daily contact with Floyd and his Associates regarding the energy devices. I was not that important and basically only accompanied my doctor brother to meetings and kind of "got lost in the woodwork". Intellectually, I really was not a threat to anyone. I was only there at meetings to help acquire venture capital.

On the very day that my doctor brother died, my electronics brother and I were at the home of John, (Floyd's Associate from NASA) who for some strange reason had followed my brothers and I to our home city where we lived, bought a home and took up residence there. We did not complain as he was our go-between with Floyd. But the move still seemed strange to me. The reason my electronics brother and I were with John is that John had arranged a conference call with Floyd and us, to see if there was a possibility for Floyd to make some type of energy device which could power the magnet motor that Ron Brandt had. My brothers and I had all the contractual rights to Ron's Magnet Motor which could be used in any car. I thought to myself that now I can really find out how "real" Ron (who could not even spell "electric") was when I matched him up with Floyd from MIT. I could not believe what I heard as Floyd and Ron conversed at the highest electronic levels - "who the 'hell' is Ron?" I thought. Floyd agreed that he would have no problem doing the prototype for Ron's Magnet Motor to power the car.

Floyd mainly worked with my electronics brother on this project as Floyd needed old vacuum tubes which my electronics brother had to acquire for the device and my electronics brother was a real "bench" person which Floyd seemed to favour over academic Electrical Engineers.

During the Spring of 1995, while Floyd was working on our energy device for the car, John (from NASA) and Floyd were elated that there was supposed to be an announcement from the White House regarding Floyd's VTA Energy Device. It seems that Floyd was a past friend of Senator John Glen (the former NASA astronaut) and he had given Glen one of the energy devices. Unfortunately, Glen gave the device to the Department of Energy, who, according to Floyd, passed the device on to General Motors. Floyd was furious and as I understood Floyd was then going to sue GM for two hundred million dollars. As far as I know Floyd never got the device back. I will always remember the extreme disappointment on the faces of Floyd and John when they realised that the trip to Washington DC for the announcement, was not going to take place.

In July 1995, Floyd let us know that the Energy Device was finished and we were to take possession of it. Floyd now lived in Desert Palms, California and that is where we would pick it up. After much thought, we decided we better not board a plane with the device as we were not sure of any magnetic effects on the instruments of the plane in having it transported - it was new technology which still had many questions to be answered. Instead, we decided to drive our car to Desert Palms and bring the device back ourselves.

Floyd called us the day before we were to leave and asked us if he could keep the device for a couple of extra days. He said he had "someone" coming (I thought he said China) and wanted to show them the device. We said ok, we would plan to pick it up when he was done.

A day later, at about 7:00 am Pacific time, there was a frantic call from Floyd's wife Violet (Floyd's wife Rose had died and he had re-married) to my electronics brother's house. My electronics brother was not at home and my sister-in-law, his wife, took the call from Violet. Violet was very traumatised when she told my sister-in-law that Floyd was dead. There was a lot of shouting going on in the background. The people who were there claimed they were from the FBI and that Floyd's equipment belonged to them. Rose was extremely confused with the death of Floyd and people she had never seen before taking all the equipment out of her house to waiting vans. She asked my sister-in-law what to do and my sister-in-law had NO idea as she was not aware of what my brothers and I had going on!

Violet also said that about 5:00 pm the previous night, two men whom she had never seen before, showed up to see Floyd. Floyd was with them for a period of time and then they left. At about 8:00 pm, Floyd was having a cup of coffee when he fell out of the chair on to the floor. She called for an ambulance and when they arrived they would not let her ride with them. Violet was 75 years old and didn't drive. About twenty minutes later the ambulance called back to Violet and told her they didn't think Floyd was going to "make it"!! As I understand it, Floyd's body was cremated. How soon afterwards, I don't know. The end result for my brothers and I is that ALL of our energy equipment that Floyd made for us was taken - By Whom??

Who were the two men who met with Floyd a few hours before his death? Was anything put in Floyd's coffee by these men? Violet said she had never seen them before and they seemed strange!

Why could Violet not go with her husband in the ambulance? I have seen it happen many times when family is allowed, especially where age is concerned!

How did the FBI (if that is who they were) know that Floyd was dead and show up in the very early morning (about 6:00 am) just hours after he died late at night?

YOU BE THE JUDGE - ALL I KNOW IS THAT ALL OF OUR ENERGY DEVICES (MEDICAL AND CAR-MAGNET MOTOR) ARE GONE!!! WHERE ARE THEY AND WHO ARE THE ONES RESPONSIBLE FOR TAKING THEM ??

Here are some of the known facts about Floyd's energy device:

The invention is a unified-field device and so combines both electromagnetic and gravitational effects in the same unit. For a tiny power input of just 0.31 milliwatt, the unit produces over 500 watts of output power, which is an energy gain of more than 1,500,000. The prototype, has no moving parts, is about 6" x 6" x 4" in size and taps an inexhaustible source of energy. To date, up to one kilowatt of power has been produced in actual tests which required only tiny input power to make the device operate.

Our normal day-to-day energy is "positive energy". The energy produced by Floyd's device is "negative energy" but in spite of this, it powers ordinary equipment, producing light and heat as normal. A device like this has to have a major impact on the world as we know it, because:

1. It can be easily built. The components are quite ordinary and the cost of the materials in the demonstration prototype was only a few hundred US dollars and it was constructed in just a few hours, using simple tools and equipment.
2. The test results are so impressive that there can be no question of errors of measurement when the energy gain is of the order of 1,500,000 times.
3. It demonstrates with laboratory precision that the 'law' of Conservation of Energy does not appear to apply during the operation of this device, which is something which most scientists have difficulty in accepting.

The device has very high performance. When a 1-milliwatt 60Hz sine wave is fed into it, the out put powers 500 watts of standard mains-voltage light bulbs, producing both heat and light. The device has a positive-feedback loop so it's gain is depends directly on the output load and the input power remains unchanged. So to increase the output power, all that is necessary is to connect extra light bulbs or equipment across the output.

When a motor was connected in addition to the light bulbs, the motor ran perfectly well under load and the light bulbs remained as bright as ever. Because it is a "cold electricity" device, the wires feeding the load can be very much smaller in diameter than would be normal for the load and these wires run cold at all times. When the power hits the resistance of the filaments of the light bulbs, it converts into conventional "hot electricity" and the filaments perform in exactly the same way as they do when powered by "hot electricity".

In 1988, Floyd produced a paper which he considered to be very important. The following text is an attempt to reproduce the content his highly mathematical style of presentation. If you are not into complicated mathematical presentations, then just move on past and don't worry about the following technical material, or alternatively, take a quick skim through it and don't bother with the maths. Floyd says:

What is thought of as "empty space" actually contains almost everything in the universe. It is home to all kinds of invisible energy fields and is seething with all kinds of very real forces.

Every kind of matter produces an energy field and these energy fields interact with each other in many complicated ways, producing all sorts of additional effects. These energy fields are the "stuff" of space, or as it is sometimes described, "the virtual vacuum". Space is packed full of all sorts of things but because it does not contain air, we tend to think that there is nothing at all in it. Most people think that "vacuum" means "without air" but when scientists speak of space as "the vacuum" they do not mean that at all, and they use the word "vacuum" to describe (loosely speaking) the place which is between the stars and planets of the universe, and Floyd refers to that vast place as "the vacuum", so please don't think that it has anything to do with air, as it definitely doesn't.

Floyd says: We all think that we know what light is, but the reality is that a particle of light is nothing more than a large interference in the electromagnetic field. Unless it interacts with matter or with another field, any electromagnetic field will not be changed in any way by the vacuum. Electromagnetic fields are a fundamental part of the structure of the vacuum itself. The whole universe is permeated by a constant magnetic field. That field is made up of countless numbers of North and South pole magnets in a completely random scatter.

Einstein has pointed out that $E = mc^2$ which is one way of saying that energy and matter are interchangeable (or are two different faces of the same thing). The energy everywhere in the universe is so great that new particles of matter pop into existence and drop back into their energy form many trillions of times per second. Actually, they exist for such a very short time that calling them "particles" is not really appropriate, so perhaps "virtual particles" might be a better description.

However, if we generate a moving magnetic field, it alters the random nature of this energy in the tiny part of the vacuum where we happen to be, and the vacuum energy becomes much less random and allows a very large amount of vacuum energy to be drawn into our equipment and do what we think of as "useful work" - producing heat and light, powering motors and vehicles, etc. This was proved in laboratory experiments during the week of 19th June 1988 and it is the underlying operating principle of my "Phase-Conjugated Vacuum Triode" device.

The energy produced by this device is "negative energy" which is the reverse of the energy with which we are familiar. The spark caused by a short-circuit in a negative energy system is excessively bright and cold and it produces a barely audible hiss with no explosive force. Melting of wires does not occur and this type of negative current passes through the human body with only the feeling of a chill.

Wires which carry a lot of negative energy remain cool at all times and so tiny wires can feed equipment with hundreds of watts of power. This has been demonstrated in the laboratory and the source of energy is unlimited as it is the virtual vacuum of space itself.

The Nature of Space:

Space itself is the ability to accommodate energy. Consider for a moment, the following illustration:

A signal (energy) is transmitted from point "A" to point "B" which are separated by a finite distance. Consider three periods of time:

1. The signal is launched from point A.
2. The signal resides in the space between point A and point B.
3. The signal arrives at point B.

If 3. occurs simultaneously with 1. we say that the signal has travelled at infinite velocity. If that were the case, then the signal never resided in the intervening space and therefore there must be no space between point A and point B and so both points A and B must be at the same location. For real space to exist between the two points, it is necessary that a signal moving between them has to get "lost" to both points, that is, out of touch with both points for a finite period of time.

Now, we know that for real space to exist between two points, a signal passing between them has to move at a finite speed between them and if it can't do that, then there can't be any space between them. If space can't accommodate a signal passing between two points, then it has no function and no reality. We are left then with the only real space, the home of the real and virtual vacuum - space which supports a finite, non-zero signal velocity.

A similar argument applies to the impedance of space. A medium can only accommodate positive energy if the medium resists it to a reasonable degree. Neither an infinitely strong spring nor an infinitely weak spring can absorb energy by being compressed. Neither an infinitely large mass nor an infinitely small mass can absorb or accommodate energy imparted by a collision and the same holds true for space.

Energy cannot enter a space of zero impedance any more than a force can bear on a mass of zero magnitude. Similarly, energy could not enter space which has an infinite impedance. It follows therefore, that real space must have:

1. Finite propagation velocity and
2. Finite impedance.

Another way of looking at this is instead of considering the actual speed of propagation of a signal through space, to consider the length of time "t" which it takes the signal to pass through that part of space. We can think of a section of space as being, say, 1 nanosecond wide if it takes a signal 1 nanosecond to traverse it. That is, the energy or signal entering that part of space, leaves it again 1 nanosecond later. Signal propagation speed in the space in which we live is at the speed of light.

General Description of Energy Transfer:

Consider energy flowing straight and level down a transmission line. The energy does not "know" the width of the channel through which it is passing. If the energy flow reaches a point where the conductivity of the channel lowers but the size and shape of the channel remain the same, then not as much energy can flow and some gets reflected back along the channel. The energy current will not "know" if (a) the conductivity has changed or (b) the geometry has changed. The energy current can change direction very easily and so as far as it is concerned, the change caused by (a) is equivalent to the change caused by (b).

The channel through which the energy flows has width and height and the width divided by the height is called the "aspect ratio" of the channel. Energy current has an aspect ratio and if that aspect ratio is forced to change, then some of the flowing energy will reflect so as to keep the *overall* aspect ratio unchanged.

The aspect ratio of energy current is much like the aspect ratio of space itself. While the aspect ratio of space itself can change, its fundamental velocity of "C" the speed of light in space can't really change. That speed is just our way of visualising time delay when energy resides in a region of space. Uniform space has only two parameters:

- (1) Aspect ratio and
- (2) Time delay

Aspect ratio defines the shape (but not the magnitude) of any energy flow which enters a given region of space. Velocity or length define the time during which that energy can be accommodated in a region of space.

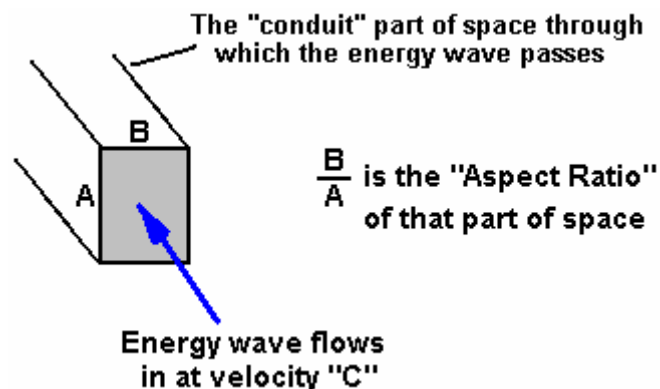

Does an energy flow travel unimpeded through an interface, or does a large part of it get reflected? Space has quiet zones through which energy glides virtually unreflected. It also has noisy zones where the energy current becomes incoherent, bounces around and splits apart. These noisy zones in space either have either rapidly changing geometry or rapidly changing impedance.

Electromagnetic Energy:

The rate of flow of energy through a surface can be calculated using "E" the Electric field, and "H" the Magnetic field intensity. The energy flow through space is $E \times H$ per unit area (of its "conduit's" cross-sectional area) and the energy density is $E \times H / C$ where C is the speed of light in space.

If there happen to be two signals of exactly the same strength, passing through each other in opposite directions in such a way that their "H" fields cancel out, then if each has a strength of $E/2$ and $H/2$, the

energy density will be $E \times H / 2C$ and it will have the appearance of a steady E-field. In the same way, if the E fields cancel out, the result will appear to be a steady "H" field.

Modern physics is based on the faulty assumption that electromagnetics contains two kinds of energy: electric and magnetic. This leads to the Baroque view of physical reality. Under that view, energy seems to be associated with the square of the field intensity, rather than a more reasonable view that it is directly to the field intensity. It is worth remembering that neither Einstein nor most modern physicists were, or are, familiar with the concept of "energy current" described here. However, their work still survives by ignoring the energy current concept, scalar electromagnetics, the works of Tom Bearden, kaluza-Klein and others who dispute Heaviside's interpretations of Maxwell's equations.

The Fallacy of Displacement Current:

Conventional electromagnetic theory proposes that when an electric current flows down a wire into a capacitor, it spreads out across the plate, producing an electric charge on the plate which in turn, leads to an electric field between the plates of the capacitor. The valuable concept of continuity is then retained by postulating a displacement current "after Maxwell". This current is a manipulation of the electric field "E" between the plates of the capacitor, the field having the characteristics of electric current, thus completing the flow of electricity in the circuit. This approach allows Kirchoff's laws and other valuable concepts to be retained even though superficially, it appears that at the capacitor there is a break in the continuous flow of electric current.

The flaw in this model appears when we notice that we notice that the current entered the capacitor at only one point on the capacitor plate. We are then left with the major difficulty of explaining how the electric charge flowing down the wire suddenly distributes itself uniformly across the entire capacitor plate at a velocity in excess of the speed of light. This paradoxical situation is created by a flaw in the basic model. Work in high-speed logic carried out by Ivor Catt has shown that the model of lumped capacitance is faulty and displacement current is an artefact of the faulty model. Since any capacitor behaves in a similar way to a transmission line, it is no more necessary to postulate a displacement current for the capacitor than it is necessary to do so for a transmission line. The removal of "displacement current" from electromagnetic theory has been based on arguments which are independent of the classic dispute over whether the electric current causes the electromagnetic field or vice versa.

The Motional E-Field:

Of all of the known fields; electric, magnetic, gravitational and motional E-field, the only ones incapable of being shielded against are the induced motional E-field and the gravitational field. The nature of the motionally-induced electric field is quite unique. In order to understand it more fully, we must start by discarding a few misleading ideas. When magnetic flux is moved perpendicularly across a conductor, an electromotive force ("e.m.f.") is electromagnetically induced "within" the conductor. "Within" is a phrase which comes from the common idea of comparing the flow of electric current within a wire to the flow of water in a pipe. This is a most misleading comparison. The true phenomenon taking place has little been thought of as involving the production of a spatially- distributed electric field. We can see that the model's origins are likely to have arising from the operation called "flux cutting" which is a most misleading term. A better term "time-varying flux modulation" does not imply any separation of lines of flux. Truly, lines of flux always form closed loops and are expressed mathematically as line integrals.

It is a fallacy to use the term "cutting" which implies time-varying separation which does not in fact ever occur. A motionally-induced E-field is actually created within the space occupied by the moving magnetic flux described above. The field is there whether or not a conductor is present in the space. In terms of a definition, we can say that when magnetic flux of vector intensity \vec{B} is moved across a region of space with vector velocity \vec{V} , an electromagnetically induced electric field vector $\vec{E} = \vec{B} \times \vec{V}$ appears in the space at right angles to both \vec{B} and \vec{V} . Therefore:

$$\vec{E} = \vec{B} \times \vec{V} \dots\dots\dots (1)$$

It is this field which is related to gravity and which is virtually unshieldable. This field may be called the Motional E-field. According to Tom Bearden, "It seems that the charged particles in the atom act like tiny magnets and their motion in the space surrounding the atom would create this motional E-field". The fields created by both the positive and negative charges would cancel to some degree, but due to the high orbital velocity of the negative electron relative to that of the positive proton, the induced field of the electron would dominate the resulting field. The field produced as a result of these charges would vary in proportion to the inverse square of the distance as gravity does. The field produced by the translational motion of the charges would vary inversely as the cube of distance. This concept totally unites the

electromagnetic and gravitational field theories and accounts for the strong and weak force within the atom.

Field Super-Position and the Vacuum Triode:

Electromagnetic induction with no measurable magnetic field is not new. It is well known that in the space surrounding a properly wound toroidal coil, there is no magnetic field. This is due to the superposition of the fields. However, when alternating current is surging through a transformer, an electric field surrounds it. When we apply the principle of super-position to the vacuum triode, it becomes more obvious how the device is operating.

The principle of super-position states that "in order to calculate the resultant intensity of superimposed fields, each field must be dealt with individually as though the others were not present" The resultant is produced by the vector addition of each of the fields considered on its own. Consider for a moment, the construction of the triode which includes two bi-filar coils located within the fields of two conditioned magnets. When the current in one half of the conductors in the coils (that is, just one strand of the twin windings in each coil) is increasing, both the current and the magnetic field follow the right-hand rule. The resulting motional E-field would be vertical to both and directed inwards. At the same time, the current in the other strand of each winding is decreasing and both the current and the magnetic field also follow the right-hand rule. The resulting motional E-field is again vertical to both, and directed inwards. So, the resultant combined field intensity is double the intensity produced by either one of the conductors considered on its own. Expressed mathematically, this is:

$$E = (B \times V) + (-B \times -V) \text{ or}$$

$$E = 2 (B \times V) \dots\dots\dots (2)$$

Where: E is the electric field intensity
 B is the magnetic field intensity and
 V is the electron drift velocity

(B x V), the first term in the equation, represents the flow of the magnetic field when the electrons are moving in one direction, while (-B x -V), the second term in the equation, defines the flow of the magnetic field when the electrons are moving in the other direction. This indicates that field intensity is directly proportional to the square of the current required by the load placed on the device. This is due to it's proportional relationship with the virtual value of the magnetic field which theory states is proportional to the current. Electrometer readings were always close to parabolic, indicating that the source was of infinite capacity. It was further determined through experiment, that the magnetic field does not change with temperature. Also, there is no reason yet identified, which would lead one to believe that electron drift velocity changes. It has been found remarkable that the vacuum triode runs approximately 20^oF below ambient.

Induced Electromotive Force - Positive Energy:

When an e.m.f. ("electromotive force") is applied to a closed metallic circuit, current flows. The e.m.f. along a closed path "C" in space is defined as the work per unit charge (that is, W / Q) done by the electromagnetic fields on a small test charge moved along path C. Since work is the line integral of Force ("F"), the work per unit charge is the line integral of force per unit charge (in Newtons per Coulomb) we have:

$$\text{e.m.f.} = \int_C F / Q \times dt dl \text{ volts} \dots\dots\dots (3)$$

The scalar product "(F/Q) x dt dl" is the product of (F/Q) x Cosθ x dl where θ denotes the angle between the vectors F/Q and dl.

The electric force per unit charge is the electric field intensity ("E") in volts per metre. The magnetic force per unit charge is V x B where "V" denotes the velocity of the test charge in metres per second and "B" denotes the magnetic flux density in webers per metre squared. In terms of the smaller angle θ between V and B, the cross product of V and B is a vector having the magnitude VBSinθ. The direction of vector V x B is at right angles to the plane which contains vectors V and B in accordance with the right-hand rule (that is, V x B is in the direction of the thumb while the fingers curl through the angle θ from V towards B). Since the total force per unit charge is E + VB, the total e.m.f. in terms of the fields is:

$$\text{e.m.f.} = \int_C (\mathbf{E} + \mathbf{V} \times \mathbf{B}) \cdot d\mathbf{l} \dots \dots \dots (4)$$

It appears from equation (4) that the e.m.f. depends on the forward velocity with which the test charge moves along the path C. This, however, is not the case. If V and dl in equation (4) have the same direction, then their associated scalar product is zero. So, only the component of V which is not aligned with dl (that is, with $\theta = 90^\circ$), can contribute to the e.m.f. This component has value only if the differential path length dl has a sideways motion. So, V in equation (4), represents the sideways motion of dl, if there is any. The fields E and B in equation (4) could well be represented as functions of time as well as functions of the space co-ordinates. In addition, the velocity V of each differential path length dl, may vary with time. However, equation (4) correctly expresses the e.m.f. or voltage drop along path C as a function of time. That component of the e.m.f. consisting of the line integral $\mathbf{V} \times \mathbf{B}$ is the motional E-field since it has value only when path C is moving through a magnetic field, traversing lines of magnetic flux. For stationary paths, there is no motional E-field and the voltage drop is simply the integral of the electric field "E". Devices which separate charges, generate e.m.f.s and a familiar example of this is a battery which utilises chemical forces to separate charge. Other examples include the heating of a thermocouple, exposure of a photovoltaic cell to incident light or the rubbing together of different material to produce electrostatic charge separation. Electric fields are also produced by time-varying magnetic fields. This principle is already exploited extensively in the production of electrical power by the utility companies.

The line integral of electric field intensity "E" around any closed path "C" equals $-\frac{d\phi}{dt}$ where ϕ represents the magnetic flux over any surface "S" having the closed path "C" as its contour. The positive side of the surface S and the direction of the line integral around contour C, are related by the right-hand rule (the curled fingers are oriented so as to point around the loop in the direction of integration and the extended thumb points out the positive side of the surface S). The magnetic flux ϕ is the surface integral of magnetic flux density "B" as shown here:

$$\phi = \iint_S \mathbf{B} \cdot d\mathbf{s} \quad \text{webers} \dots \dots \dots (5)$$

In Equation (5), the vector differential surface "ds" has an area of ds and in direction, it is perpendicular to the plane of ds, projecting out of the positive side of that surface. The partial time derivative of ϕ is defined as:

$$\frac{\partial \phi}{\partial t} = \iint_S \frac{\partial \mathbf{b}}{\partial t} \cdot d\mathbf{s} \quad \text{volts} \dots \dots \dots (6)$$

This is referred to as the magnetic current through surface S. For a moving surface S, the limits of the surface integral in equation (6) are functions of time, but the equation still applies. It is important to clarify at this point, that when we evaluate the value of $\frac{d\phi}{dt}$ over a surface which is moving in proximity to magnetic field activity, we treat the surface as though it were stationary for the instant under consideration. The partial time derivative of ϕ , is the time rate of change of flux through surface S, due only to the changing magnetic field density B. Any increase of ϕ due to the motion of the surface in the B-field, is not included in that calculation.

Continuing this discussion leads us to note that an electric field must be present in any region containing a time-varying magnetic field. This is shown by the following equation:

$$\oint_C \mathbf{E} \cdot d\mathbf{l} = -\frac{\partial \phi}{\partial t} \dots \dots \dots (7)$$

In this equation, ϕ is the magnetic flux in webers out of the positive side of any surface having path C as its contour. Combining equations (7) and (4), we are able to calculate the e.m.f. about a closed path C as shown here:

$$\text{e.m.f.} = \oint_C \mathbf{E} \times d\mathbf{l} + \oint_C (\mathbf{V} \times \mathbf{B}) d\mathbf{l} \dots\dots\dots (8)$$

or in another form:

$$\text{e.m.f.} = \frac{-\partial\phi}{\partial t} + \oint_C (\mathbf{V} \times \mathbf{B}) d\mathbf{l} \dots\dots\dots (9)$$

So, the e.m.f. around a closed path consists in general of two components. The component $d\phi/dt$ is the variational e.m.f. and the second component is the motional E-field. In equation (9), $(\mathbf{V} \times \mathbf{B})d\mathbf{l}$ can, by means of a vector identity, be replaced with $\mathbf{B} \times (\mathbf{V} \times d\mathbf{l})$. \mathbf{V} is the sideways velocity of d : the vector $\mathbf{V} \times d\mathbf{l}$ has magnitude Vdl and a direction normal to the surface ds swept out by the moving length $d\mathbf{l}$ in time dt . Letting B_n denote the component of \mathbf{B} normal to this area, we can see that the quantity $-\mathbf{B} \times (\mathbf{V} \times d\mathbf{l})$ becomes $-B_n V d\mathbf{l}$ and equation 9 can be re-written as:

$$\text{e.m.f.} = \frac{-\partial\phi}{\partial t} + \oint_C B_n V d\mathbf{l} \dots\dots\dots (10)$$

Clearly, the integral of $B_n V$ around the closed contour C with sideways velocity of magnitude V for each length $d\mathbf{l}$ traversed, is simply the time rate of change of the magnetic flux through the surface bounded by C . This change is directly due to the passage of path C through lines of magnetic flux. Hence, the complete expression for e.m.f. in equation (10) is the time rate of change of the magnetic flux over any surface S , bounded by the closed path C , due to the changing magnetic field and the movement of the path through the magnetic field. Equation (10) may be written:

$$\text{e.m.f.} = -d\phi / dt \dots\dots\dots (11)$$

Note: The distinction between equations (7) and (11) is that equation (7) contains only the variational e.m.f. while equation (11) is the sum of the variational and motional e.m.f. values. In equation (7), the partial time derivative of magnetic flux ϕ is the rate of flux change due only to the time-varying magnetic field, while equation (11) includes the total time derivative of the rate of flux change due to the time-varying magnetic field and path C 's passage through the magnetic field. If the closed path C is not passing through lines of magnetic flux, then equation (7) and equation (11) are equivalent.

It is also important to point out that $d\phi/dt$ in equation (11) does not necessarily mean the total time rate of change of the flux ϕ over the surface S . For example, the flux over surface S is bounded by the closed contour C of the left portion of the electric circuit shown in Fig.1.

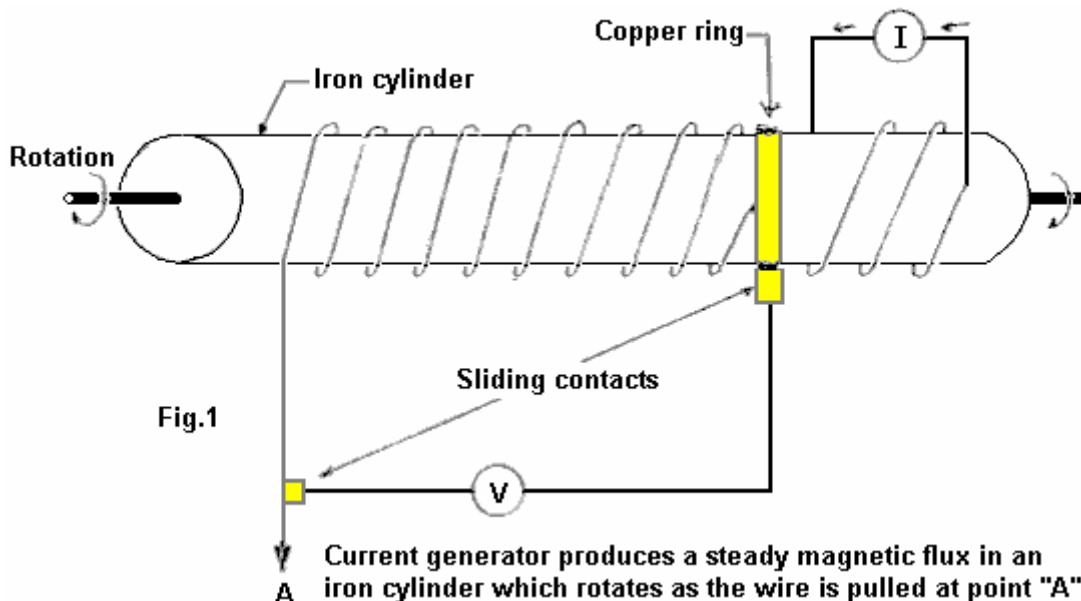

Fig.1

Current generator produces a steady magnetic flux in an iron cylinder which rotates as the wire is pulled at point "A"

The flux is changing as the coil is unwound by the rotation of the cylinder, as illustrated. However, since \mathbf{B} is static, there is no variational e.m.f. and since the conductors are not modulating lines of flux, there is

no motional e.m.f. Thus, $d\phi/dt$ in equation (11) is zero, even though the flux is changing with time. Note that $d\phi/dt$ was defined as representing the right hand part of the expression in equation (10) and $d\phi/dt$ must not be interpreted more broadly than that.

In the application of the present equations, it is required that all flux densities and movements are referred to a single, specified co-ordinate system. In particular, the velocities will all be with respect to this system alone and not interpreted as relative velocities between conductors or moving lines of flux. The co-ordinate system is selected arbitrarily and the magnitudes of variational and motional fields depend upon the selection.

Example 1:

A fundamental electric generator is shown in Figure 2:

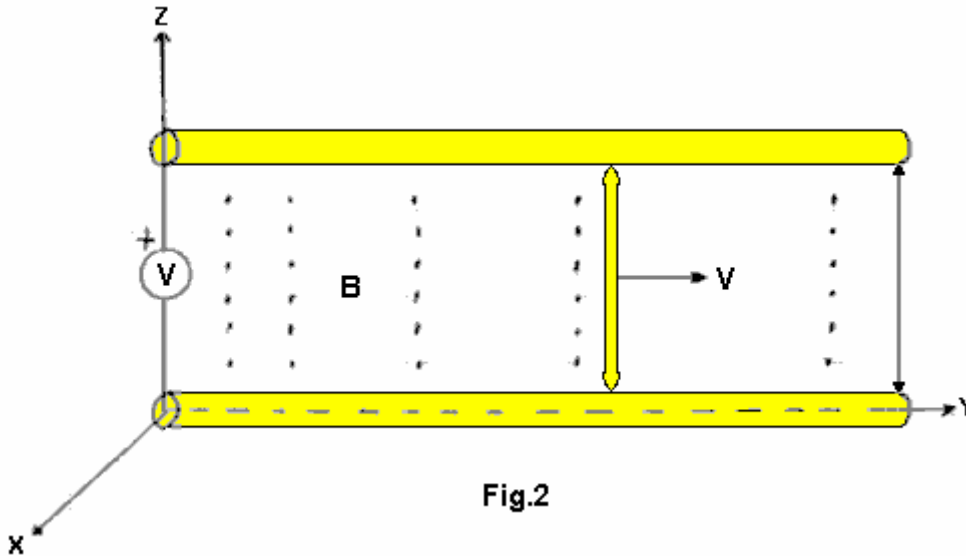

Fig.2

The parallel, stationary conductors, separated by distance "l", have a stationary voltmeter connected across them. The circuit is completed by a moving conductor connected to the parallel conductors by means of two sliding contacts. This conductor is connected at $y = 0$ at time $t = 0$, and it moves to the right at a constant velocity $V = V_{ay}$. The applied flux B is represented by dots on Fig.2 and has a magnitude of $B = B_0 \cos B_y \cos \omega t \text{ ax}$. The unit vectors in the direction of the co-ordinate axes are a_x , a_y and a_z respectively.

Solution: Let S denote the plane rectangular surface bounded by the closed electric circuit, with a positive side selected as the side facing you. The counter-clockwise e.m.f. around the circuit is $d\phi/dt$ with ϕ signifying the magnetic flux out of the positive side of S (As $ds = 1 \text{ dy ax}$). The scalar product $B \times ds$ is $B_0 l \cos B_y \cos \omega t \text{ dy}$; integrating from $y = 0$ to $y = y$ gives:

$$\phi = B_0 l \sin B_y \cos \omega t \dots\dots\dots (12)$$

With y_1 denoting the instantaneous y position of the moving wire. The counter-clockwise e.m.f. is found by replacing y with vt and evaluating $d\phi/dt$. The result is:

$$\text{e.m.f.} = \omega B_0 l \sin B_y \sin \omega t - B_0 l v \cos B_y \cos \omega t \dots\dots\dots (13)$$

The variational (transformer) component is determined with the aid of equation (12) and is $\omega B_0 l \sin B_y \sin \omega t$ where $y = vt$. This is the first component on the right hand side of equation (13).

Note: y_1 was treated as a constant when evaluating the partial time derivative of ϕ .

The motional E-field is the line integral of $V \times B$ along the path of the moving conductor. As $V \times B$ is $-B_0 v \cos B_y \cos \omega t \text{ ax}$ and $As \text{ dl}$ is $dz \text{ ax}$, evaluation of the integral $-B_0 v \cos B_y \cos \omega t \text{ dz}$ from $Z = 0$ to $Z = l$ results in a motional E-field of $-B_0 l v \cos B_y \cos \omega t$. This component results from modulation of the lines of flux by the moving conductor. If the voltmeter draws no current, there can be no electromagnetic force on the free electrons of the wire. Therefore, the e.m.f. along the path of the metal conductors including the moving conductor, is zero.

Example 2:

Suppose the conductor with the sliding taps is stationary ($V = 0$) and it is located at $y = y_1$. Also, suppose that the magnetic field B is produced by a system of moving conductors which are not shown in Fig.2 and those conductors are travelling with a constant velocity $V = Vay$. At time $t = 0$, the magnetic field B is $B_0 \sin B y ax$. Determine the voltage across the voltmeter.

Solution: There is no motional E-field because the conductors in Fig.2 are at rest (stationary) with respect to our selected co-ordinate system. However, the magnetic field at points fixed with respect to the co-ordinate system is changing with time and as a result, there is a variational e.m.f. Since the B-field at time $t = 0$ is $B_0 \sin B y ax$ and has a velocity of $V = Vay$, it can be calculated that the B-field as a function of time is $B_0 \sin[B(y-vt)] ax$. This is verified by noting that an observer located at time $t = 0$ who is travelling at the constant velocity ($V = Vay$) of the moving current, would have a y co-ordinate of $y = y + Vt$ and an accordingly different expression for B . He would observe a constant field where the magnetic current density is:

$$\frac{\partial B}{\partial t} = -BvB_0 \cos B(y - Vt) ax$$

The counter-clockwise e.m.f. can be arrived at by taking the negative of an integral of the above expression for the rectangular surface bounded by the electric circuit with the positive side facing you, with the limits of zero and y . The resulting e.m.f. equals:

$$B_0lv[\sin B(y_1 - vt) + \sin Bvt]$$

which is the voltage across the meter.

Induced Motional Field - Negative Energy:

Conventional theory says that electric fields and magnetic fields are different things. Consider for a moment, a charge with an electric field around it. If the charge is moved, then a magnetic field develops and the moving charge constitutes a current. If an observer were to move along with the charge, then he would see no relative motion, no current and no magnetic field. A stationary observer would see motion, current and a magnetic field. It would appear that a magnetic field is an electric field observed from a motional reference frame. Similarly, if we take a mass with a gravity field around it, and we move the mass and create a mass current, a new field is also created. It is a different kind of gravity field with no source and no sink. It is called the "Protational field" and is also known as the "Lense-Thirring Effect". This field and it's governing principles will form the basis for future anti-gravitational devices (see figures 1 to 4).

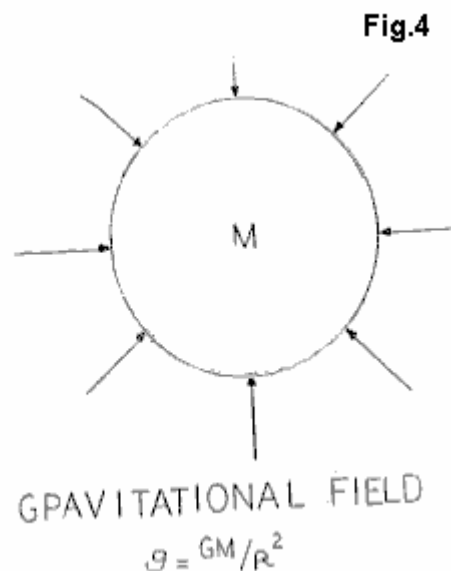
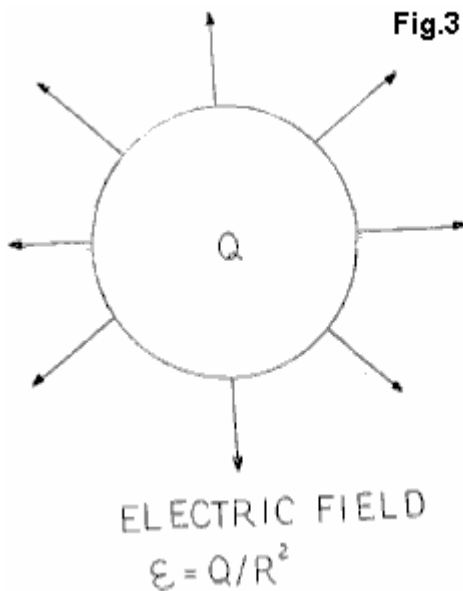

Within the confined are of the Vacuum Triode box, the space-time continuum is reversed by the fields which are produced in the presence of excited coherent space flux quanta. These quanta have been attracted form, and ultimately extracted from the virtual vacuum, the infinitely non-exhaustible Diac Sea. For a more detailed mathematical format see Tom Bearden's paper "The Phase Conjugate Vacuum Triode" (23rd April 1987). Much of the theory which likely applies to the vacuum triode has been developed in the field of phase-conjugate optics.

With regards to over-unity phenomena, it is important to note that so long as positive energy is present in a positively-flowing time regime, then unity and over-unity power gains are not possible. The summation of the losses due to resistance, impedance, friction, magnetic hysteresis, eddy currents and windage losses of rotating machinery will always reduce overall efficiency below unity for a closed system. The laws of conservation of energy always apply to all systems. However, the induced motional E-field changes the system upon which those laws need to be applied. Since the vacuum triode operates in more than four dimensions and provides a link between the multi-dimensional reality of the quantum state and the Dirac Sea, we are now dealing with an open-ended system and not the "closed system" within which all conservation and thermodynamic laws were developed.

To achieve unity, the summation of all magnetic and ohmic losses must equal zero. To achieve this state, negative energy and negative time need to be created. When this is achieved, all ohmic resistance becomes zero and all energy then flows along the outside of conductors in the form of a special space field. Negative energy is fully capable of lighting incandescent lights, running motors and performing all of the functions of positive energy tested to date. When run in parallel with positive energy however, cancellation (annihilation) of opposing power types occurs. This has been fully tested in the laboratory.

Once unity has been achieved and the gate to the Dirac sea opened, over-unity is affected by loading the open gate more and more, which opens it further to the point where direct communication / interaction with the nucleus of the atom itself is achieved. Output of the vacuum triode is not proportional to the excitation input as the output produced by the device is directly proportional to the load which is placed on it. That load is the only dependent variable for device output. The triode's output voltage and frequency always remains constant due to the conditioning of the motional E-field in the permanent magnets and the small regulated excitation signal which is provided through a small oscillator. Regulation remains constant and the triode output looks into an in-phase condition ($\cos\theta=1$ Kvar=1) under all load characteristics.

the vacuum triode is a solid-state device consisting of conditioned permanent magnets capable of producing a motional field. This field opens the gate to the Dirac Sea from where negative energy flows into the triode's receiving coils. The coils are wound with very small-diameter wire but in spite of that, they are capable of producing more than 5 kilowatts of useful power. This in itself, is a clear indicator that the type of electrical energy collected by the device is not conventional electrical energy. The wire sizes used in the construction of the device would not be capable of carrying such large currents without excessive heat gain, however, the triode's coils actually run cooler when loaded at 5 kilowatts.

The fundamental magnets have been broken free of the binding forces which constrained them to be steady-state single-pole uniform magnetic flux devices. They are now able to simply support mass, as demonstrated with the transformer steel illustration. They can now easily be made to adopt a dynamic motional field by applying a tiny amount of excitation. Specifically, 1 milliamp at 10 volts (10 milliwatts) of excitation at 60 Hz enables the coils of the triode to receive from the Dirac Sea, more than 5,000 watts of usable negative energy. It has not yet been determined how much more energy can be safely removed.

Meguer Kalfaian's Energy Generator

There is a patent application which has some very interesting ideas and claims. It has been around for a long time but it has not been noticed until recently. Personally, I get the impression that it is more a concept rather than a solidly based prototype-proven device, but that is only my impression and you need to make up your own mind on the matter.

Patent Application GB 2130431A

31st May 1984

Inventor: Meguer Kalfaian

Method and means for producing perpetual motion with high power

ABSTRACT

The perpetual static energies, as provided by the electron (self spin) and the permanent magnet (push and pull) are combined to form a dynamic function. Electrons emitted from a heated coil **F** are trapped permanently within the central magnetic field of a cylindrical magnet **M5**. A second magnet **M6**, in opposite polarity to the poles of the electrons causes polar tilt, and precession. This precession radiates a powerful electromagnetic field to a coil **L** placed between the cylindrical magnet and a vacuum chamber **C** - wound in a direction perpendicular to the polar axes of the electrons. Alternatively, the electromagnetic radiation is emitted as coherent light. The original source of electrons is shut off after entrapment.

SPECIFICATION

Method and means for producing perpetual motion with high power. This invention relates to methods and means for producing perpetual motion. An object of the invention is, therefore, to produce useful perpetual motion for utility purposes.

BRIEF EMBODIMENT OF THE INVENTION

The electron has acquired self spin from the very beginning of its birth during the time of creation of matter, and represents a perpetual energy. But self spin alone, without polar motion is not functional, and therefore, useful energy cannot be derived from it. Similarly, the permanent magnet represents a source of perpetual energy, but since its poles are stationary, useful energy cannot be derived from it.

However, the characteristics of these two types of static energies differ one from the other, and therefore the two types of energies can be combined in such a manner that, the combined output can be converted into perpetual polar motion.

In one exemplary mode, a cylindrical vacuum chamber having a filament and a cathode inside, is enclosed within the central magnetic field of a cylindrical permanent magnet, the magnetisation of which can be in a direction either along the longitudinal axis, or from the centre to the circumferential outer surface of the cylinder. When current is passed through the filament, the electrons emitted from the cathode are compressed into a beam at the centre of the cylindrical chamber by the magnetic field of the cylindrical magnet. Thus, when the current through the filament is shut off, the electrons in the beam remain permanently trapped inside the magnetic field.

In such an arrangement, the poles of the electrons are aligned uniformly. When a second permanent magnet is held against the beam in repelling polarity, the poles of the electrons are pushed and tilted from their normal longitudinal polar axes. In such tilted orientations, the electrons now start wobbling (precessing) in gyroscopic motions, just like a spinning top when it is tilted to one side. The frequency of this wobbling (precessional resonance) depends upon the field strengths of the two magnets, similar to the resonance of the violin string relative to its tensional stretch. The polar movements of the electrons radiate an electromagnetic field, which can be collected by a coil and then converted into any desired type of energy. Because of the uniformly aligned electrons, the output field is coherent, and the output power is high.

Observed examples upon which the invention is based:

The apparatus can best be described by examples of a spinning top in wobbling motion. Thus, referring to the illustration of **Fig.1**, assume that the spinning top **T** is made of magnetic material, as indicated by their pole signs (**S** and **N**). Even though the top is magnetic, the spin motion does not radiate any type of field, which can be received and converted into a useful type of energy. This is due to the known fact that, radiation is created only when the poles of the magnet are in motion, and in this case, the poles are stationary.

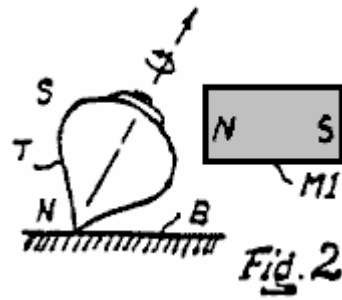
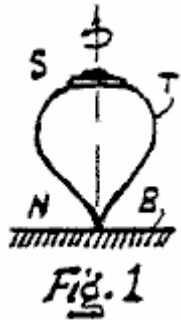

When a magnet **M1** is held from a direction perpendicular to the longitudinal polar axis of the top, as shown in **Fig.2**, the polar axis of the top will be tilted as shown, and keep on spinning in that tilted direction. When the magnet **M1** is removed, however, the top will try to regain its original vertical posture, but in doing so, it will wobble in gyroscopic motion, such as shown in **Fig.3**. The faster the top spins, then the faster the wobbling motion will be.

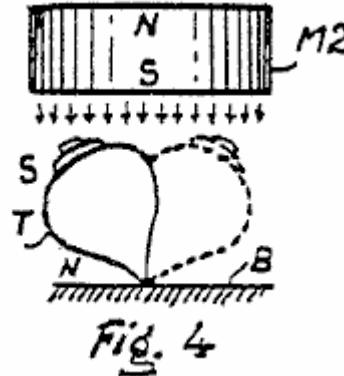
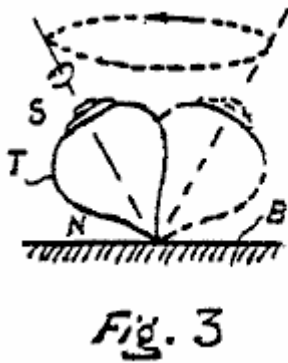

The reason that the top tilts angularly, but does not wobble when the magnet **M1** is held from horizontal direction, is that, the one-sided pull prevents the top from moving away from the magnetic field for free circular wobble. Instead of holding the magnet **M1** from the side of the top, we may also hold the magnet from a direction above the top, as shown in **Fig.4**. In this case, however, the polar signs between the magnet and the top are oriented in like signs, so that instead of pulling action, there is pushing action between the magnet and the top - causing angular tilt of the top, such as shown in **Fig.4**. The pushing action of the magnetic field from above the top is now equalised within a circular area, so that the top finds freedom to wobble in gyroscopic rotation.

The important point in the above given explanation is that, the top tries to gain its original vertical position, but it is prevented from doing so by the steady downward push from the static magnetic field of magnet **M2**. So, as long as the top is spinning, it will wobble in a steady state. Since there is now, polar motion in the wobbling motion of the top, this wobbling motion can easily be converted into useful energy. To make this conversion into perpetual energy, however, the top must be spinning perpetually. Nature has already provided a perpetually spinning magnetic top, which is called, "the electron" - guaranteed to spin forever, at a rate of 1.5×10^{23} (one hundred fifty thousand billion billion revolutions per second).

BRIEF DESCRIPTION OF THE DRAWINGS

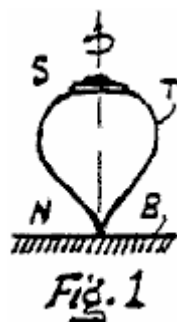

Fig.1 illustrates a magnetic spinning top, used to describe the basic principles of the invention.

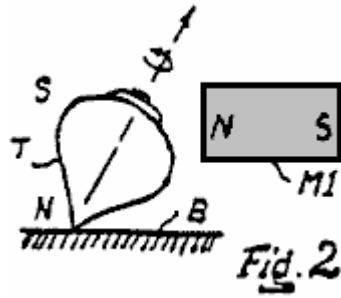

Fig.2 illustrates a controlled top for describing the basic principles of the invention.

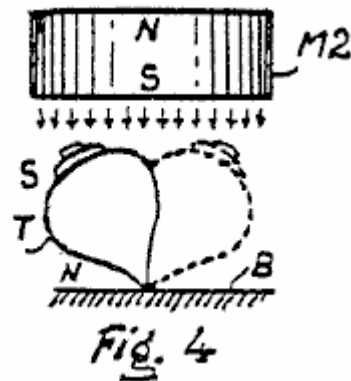
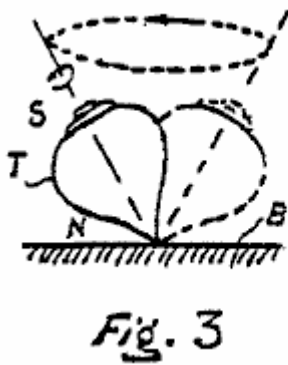

Fig.3 and Fig.4 illustrate spinning tops in wobbling states for describing the basic principles of the invention.

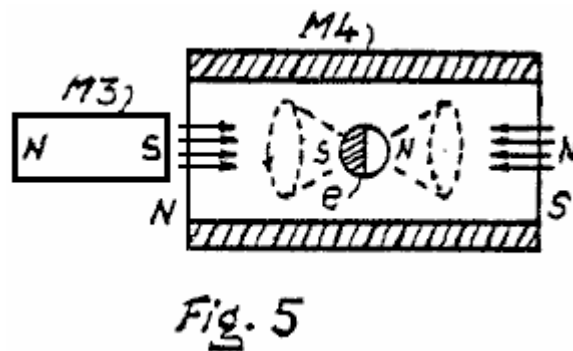

Fig.5 shows how an electron can be driven into a wobbling state under the control of permanent magnets.

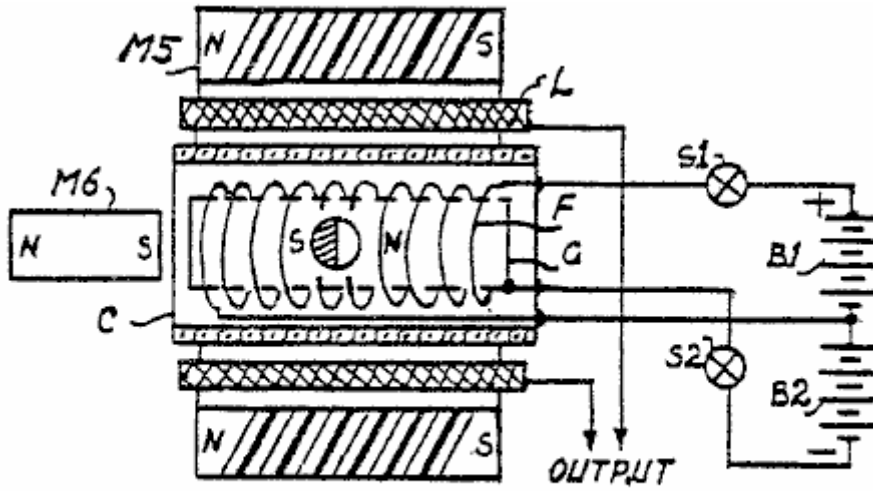

Fig. 6

Fig.6 is a practical arrangement for obtaining perpetual motion.

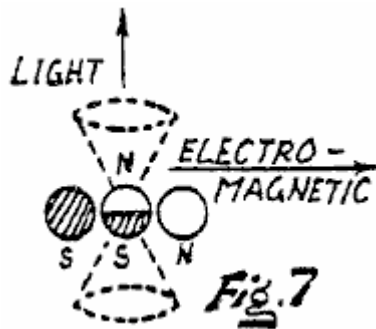

Fig.7

Fig.7 shows a natural atomic arrangement for obtaining precessional resonance.

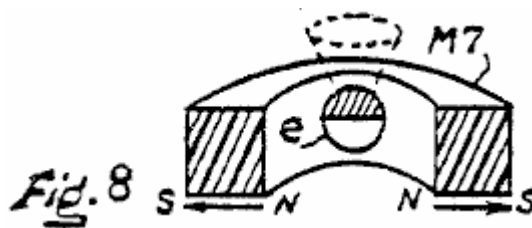

Fig.8

Fig.8 shows a different type of electron trapping permanent magnet, to that used in Fig.6.

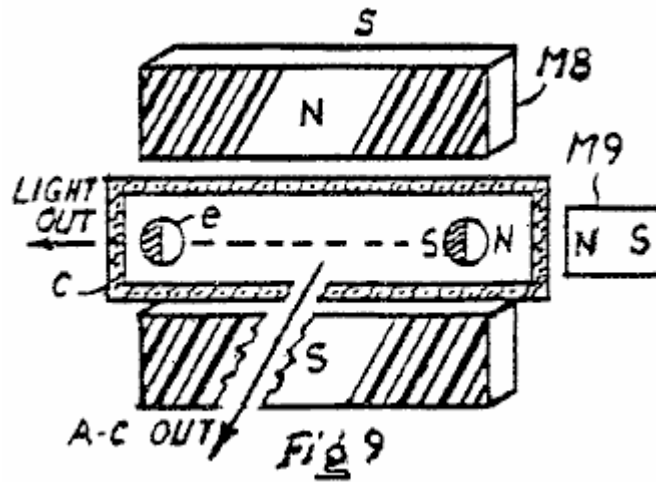

Fig.9 is a modification of Fig.6; and

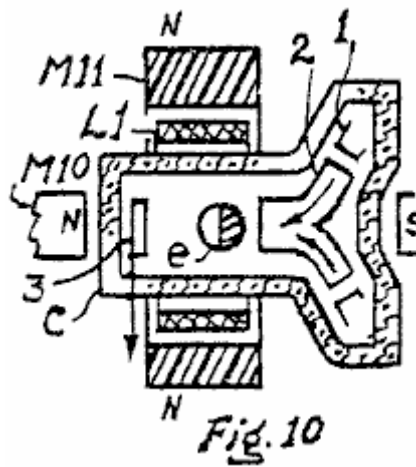
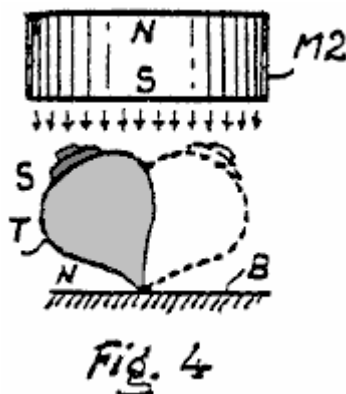

Fig.10 is a modification of the electron trapping magnets, used in Fig.6.

BEST MODE OF CARRYING OUT THE INVENTION

Referring to the exemplary illustration of Fig.4, the spinning top T is pivoted to the base B by gravity.



In the case of the electron, however, it must be held tightly between some magnetic forces. So, referring to the illustration of Fig.5, assume that an electron e is placed in the centre of a cylindrical magnet M4. The direction of

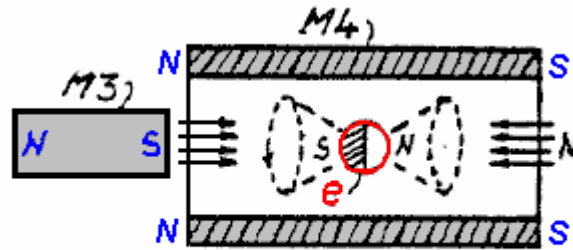

Fig. 5

magnetisation of the magnet **M4**, and the polar orientation of the electron **e** are marked in the drawing. In this case, when a permanent magnet **M3** is placed at the open end of the cylindrical magnet **M4**, the electron **e** will precess, in a manner, as described by way of the spinning top. The difficulty in this arrangement is that, electrons cannot be separated in open air, and a vacuum chamber is required, as in the following:

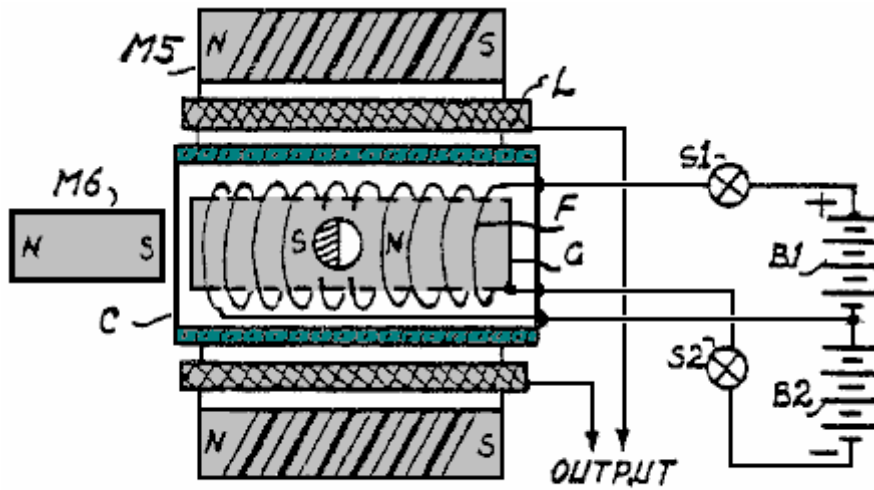

Fig. 6

Fig.6 shows a vacuum chamber **C**, which contains a cylindrically wound filament **F**, connected to the battery **B1** by way of the switch **S1**. Thus, when the switch **S1** is turned ON, the filament **F** is lighted, and it releases electrons. External to the vacuum chamber **C** is mounted a cylindrical permanent magnet **M5**, which compresses the emitted electrons into a beam at the centre of the chamber.

When the beam is formed, the switch is turned OFF, so that the beam of electrons is permanently trapped at the centre of the chamber.

The permanent trapping of the electrons in the chamber **C** represents a permanent storage of static energy. Thus, when a permanent magnet **M6** is placed to tilt the polar orientations of the uniformly poled electrons in the beam, they start precessing perpetually at a resonant frequency, as determined by the field strengths of the magnets **M5** and **M6**.

The precessing electrons in the beam will radiate quadrature phased electromagnetic field in a direction perpendicular to the polar axes of the electrons.

Thus, a coil **L** may be placed between the magnet **M5** and the vacuum chamber **C**, to receive the radiated field from the beam. The output may then be utilised in different modes for practical purposes, for example, rectified for DC power use.

The electron beam-forming cylindrical magnet **M5**, which may also be called a focusing magnet, is shown to be bipolar along the longitudinal axis. The direction of magnetisation, however, may be from the central opening to

the outer periphery of the magnet, as shown by the magnet **M7**, in **Fig.8** but the precessing magnet **M6** will be needed in either case.

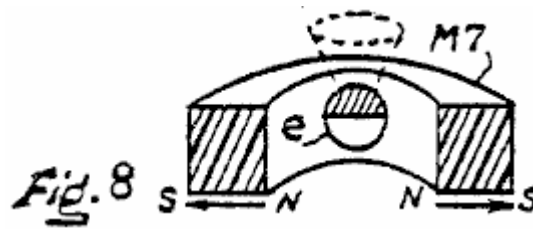

In the arrangement of **Fig.6**, I have included a current control grid **G**. While it is not essential for operation of the arrangement shown, it may be connected to a high negative potential **B2** by the switch **S2** just before switching the **S1** in OFF position, so that during the cooling period of the filament, there will occur no escape of any electrons from the beam to the cathode. Also, the grid **G** may be switched ON during the heating period of the cathode, so that electrons are not forcibly released from the cathode during the heating period, and thereby causing no damage to the cathode, or filament.

Biological precessional resonance

Electron precessional resonance occurs in living tissue matter, as observed in laboratory tests. This is called ESR (Electron Spin Resonance) or PMR (Paramagnetic Resonance). In tissue matter, however, the precessing electron is entrapped between two electrons, as shown in **Fig.7**, and the polar orientations are indicated by the polar signs and shadings, for clarity of drawing.

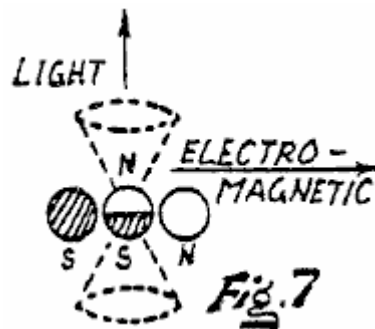

Simulation

The arrangement of **Fig.7** may be simulated artificially in a manner as shown in **Fig.9**, wherein, the electron trapping magnet is a pair of parallel spaced magnets **M8**. In actual practice, however, the structure of this pair of magnets **M8** can be modified. For example, a second pair of magnets **M8** may be disposed between the two pairs, so that the directions of the transverse fields between the two pairs cross mutually perpendicular at the central longitudinal axis of the vacuum chamber. The inner field radiating surfaces of these two pairs of magnets may be shaped circular, and the two pairs may be assembled, either by physical contact to each other, or separated from each other.

Modifications

Referring to the arrangements of **Fig.6**, **Fig.9** and **Fig.10**, when the electron is in precessional gyroscopic motion, the radiated field in a direction parallel to the polar axis of the electron, is a single phased corkscrew waveform, which when precessed at light frequency, the radiation produces the effect of light.

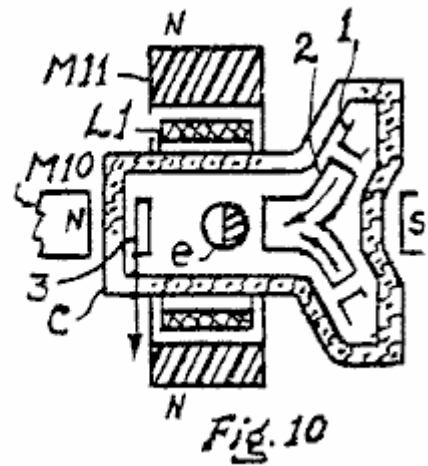
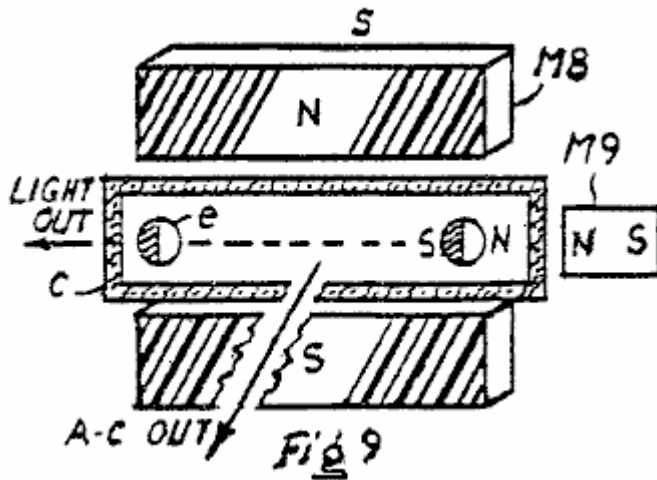

Whereas, the field in a direction perpendicular to the axis of the electron produces a quadrature phased electromagnetic radiation. Thus, instead of utilising the output of electron precession for energy purposes, it may be utilised for field radiation of either light or electromagnetic waves, such as indicated by the arrows in **Fig.9**. In this case, the output will be coherent field radiation.

In reference to the arrangement of **Fig.6**, the electron emission is shown to occur within the central magnetic field of the focusing magnet **M5**. It may be practically desired, however, that these electrons are injected into the central field of the cylindrical magnet from a gun assembly, as shown in an exemplary arrangement of **Fig.10**. In this case, the vacuum chamber **C** is flanged at the right hand side, for mounting an electron emitting cathode **1** (the filament not being shown), and a curved electron-accelerating gun **2**. The central part of this flange is recessed for convenience of mounting an electron-tilting magnet (as shown), as close as possible to the electron beam. In operation, when current is passed through the filament, and a positive voltage is applied (not shown) to the gun **2**, the emitted electrons from the cathode are accelerated and injected into the central field of the magnet **M1**. Assuming that the open end of the gun **2** overlaps slightly the open end of the cylindrical central field of the magnet **M1**, and the positive accelerating voltage applied to the gun **2** is very low, the accelerated electrons will enter the central field of the magnet **M1**, and travel to the other end of the field. Due to the low speed acceleration of the electrons, however, they cannot spill out of the field, and become permanently entrapped therein.

In regard to the direction in which the coil **L1** is positioned, its winding should be in a direction perpendicular to the longitudinal axis of the beam to which the polar axes of the electrons are aligned uniformly in parallel. In one practical mode, the coil **L1** may be wound in the shape of a surface winding around a tubular form fitted over the cylindrical vacuum chamber.

In regard to the operability of the apparatus as disclosed herein, the illustration in **Fig.7** shows that the field output in a direction parallel to the polar axis of the electron is singular phased, and it produces the effect of light when the precessional frequency is at a light frequency. Whereas, the output in a direction perpendicular to the polar axis of the electron is quadrature phased, which is manifested in practiced electromagnetic field transmission.

In regard to experimental references, an article entitled "Magnetic Resonance at high Pressure" in the "Scientific American" by George B. Benedek, page 105 illustrates a precessing nucleus, and indicates the direction of the electromagnetic field radiation by the precessing nucleus. The same technique is also used in the medical apparatus "Nuclear magnetic resonance" now used in numerous hospitals for imaging ailing tissues (see "High Technology" Nov. Dec. 1982. Refer also to the technique of detecting Electron Spin Resonance, in which electrons (called "free radicals") are precessed by the application of external magnetic field to the tissue matter. In all of these practices, the electromagnetic field detecting coils are directed perpendicular to the polar axes of the precessing electrons or the nuclei.

In regard to the production of light by a precessing electron, in a direction parallel to the polar axis of the precessing electron, see an experimental reference entitled "Free electrons make powerful new laser" published in "high Technology" February 1983 page 69.

In regard to the aspect of producing and storing the electrons in a vacuum chamber, it is a known fact by practice that the electrons are entrapped within the central field of a cylindrical permanent magnet, and they will remain entrapped as long as the magnet remains in position.

With regard to the performance of obtaining precessional resonance of the electron, the simple example of a

wobbling top is sufficient, as proof of operability.

Having described the preferred embodiments of the invention, and in view of the suggestions of numerous possibilities of modifications, adaptations, adjustments and substitutions of parts, it should be obvious to the skilled in related arts that other possibilities are within the spirit and scope of the present invention.

CLAIMS

1. The method of effecting perpetual retaining and precession of electrons, for obtaining perpetual field radiation from the polar motions of said precessing electrons, comprising the steps of:

producing electrons;
compressing said produced electrons into a perpetually retainable state; and
precessing said compressed electrons for effecting perpetual field radiation by the polar motions of said precessing electrons.

2. The method of producing perpetual field radiation for conversion into perpetual energy, the method comprising the steps of:

producing electrons;
imposing a first perpetually occurring electron controlling force from a first direction upon said produced electrons into a perpetually retainable state; and
imposing a second perpetually occurring electron controlling force from a second direction upon said retained electrons, for inducing precessional motions to the electrons, and thereby obtaining said perpetual field radiation for conversion into perpetual energy.

3. The method of generating perpetual simultaneous single phased and quadrature phased coherent field radiations, comprising the steps of:

producing electrons;
imposing a first perpetually occurring electron controlling force from a first direction upon said produced electrons into a uniformly polarised perpetually retainable compressed state; and
imposing a second perpetually occurring electron controlling force from a second direction upon said compressed electrons, for effecting precessional motions of the electrons, thereby causing a quadrature phased coherent field radiation in a direction perpendicular to the uniformly polarised polar axes of said electrons, and a simultaneous single phased coherent field in a direction parallel to the polar axes of said electrons.

4. The method of producing perpetual dynamic motions for conversion into energy, comprising the steps of:

trapping and compressing a concentrated quantity of electrons within a first electron controlling field in a vacuum space, whereby forming a tightly confined permanent concentration of statistically spinning electrons, both of their polar axes and polar orientations being uniformly aligned; and
tilting the polar axes of said trapped electrons by a second permanent electron controlling field, for inducing precessional gyrations to the electrons in the form of perpetual dynamic motions, which are adaptively convertible into energy.

5. Apparatus for producing perpetual dynamic motions, which comprises:

a vacuum chamber having an electron-emitting means; an auxiliary means for causing emission of electrons from said electron-emitting means;
a first permanent magnet disposed externally of said chamber for trapping and compressing a quantity of said emitted electrons within its magnetic field, with uniform alignments of the polar axes and polar orientations of said electrons;
means for stopping said auxiliary means from further causing emission of electrons from said electron emitting means, whereby forming a tightly confined concentration of statistically spinning electrons permanently entrapped within said first permanent magnet; and
a second permanent magnet, the field projection of which is oriented to tilt the polar axes of said trapped electrons, for causing precessional gyrations of the electrons, as representation of said dynamic motions.

6. Apparatus comprising:

a vacuum chamber having an electron emitting means;

an auxiliary means for causing emission of electrons from said electron emitting means;

a first permanent magnet disposed externally of said chamber for permanently trapping and compressing a quantity of said emitted electrons within its magnetic field, with uniform alignments of the polar axes and polar orientations of said electrons; and

a second permanent magnet so oriented with respect to said entrapped electrons that, the field projection from the second magnet causes precessional gyrations of the uniformly aligned entrapped electrons.

7. The apparatus as set forth in claim 6, wherein said first permanent magnet is cylindrical magnet surrounding said chamber, and the magnetisation of said first magnet is in a direction along the longitudinal axis of the cylinder.

8. The apparatus as set forth in claim 6, wherein said first permanent magnet is cylindrical magnet surrounding said chamber, and the magnetisation of said first magnet is in a direction from the central hollow space to the outer surface of said cylinder.

9. The apparatus as set forth in claim 6, wherein the polar sign of field projection from said second magnet to said entrapped electrons is in repelling polar sign.

10. The apparatus as set forth in claim 6, wherein is included a field responsive coil mounted between said first magnet and said vacuum chamber, for receiving the field radiation that is effected by the motions of said gyrating electrons.

11. The apparatus as set forth in claim 6, wherein is included a field responsive coil mounted between said first magnet and said vacuum chamber, the turns of winding of said coil being in a direction perpendicular to the polar axes of said compressed electrons.

12. Apparatus for producing perpetual motion, the apparatus being substantially as hereinbefore described with reference to, and as illustrated by, the accompanying drawings.

**ENERGY GENERATION APPARATUS AND METHODS
BASED UPON MAGNETIC FLUX SWITCHING**

ABSTRACT

Methods and apparatus generate electricity through the operation of a circuit based on a single magnetic flux path. A magnetisable member provides the flux path. One or more electrically conductive coils are wound around the member, and a reluctance or flux-switching apparatus is used to control the flux. When operated, the switching apparatus causes a reversal of the polarity (direction) of the magnetic flux of the permanent magnet through the member, thereby inducing alternating electrical current in each coil. The flux-switching apparatus may be motionless or rotational. In the motionless embodiments, two or four reluctance switches are operated so that the magnetic flux from one or more stationary permanent magnet(s) is reversed through the magnetisable member. In alternative embodiments, the flux-switching apparatus comprises a body composed of high-permeability and low-permeability materials, such that when the body is rotated, the flux from the magnet is sequentially reversed through the magnetisable member.

FIELD OF THE INVENTION

The present invention relates to methods and apparatus wherein the magnetic flux from one or more permanent magnets is reversed repeatedly in polarity (direction) through a single flux path around which there is wound a conducting coil or coils for the purpose of inducing electricity in the coils.

BACKGROUND OF THE INVENTION

The electromechanical and electromagnetic methods involved in motional electric generators and alternators are well known. Alternators and generators often employ permanent magnets and usually have a rotor and a stator and a coil or coils in which an EMF (electromotive force) is induced. The physics involved for producing electricity is described by the generator equation $V = \int (v \times B) \cdot dl$.

Permanent magnets made of materials that have a high coercivity, a high magnetic flux density a high magnetic motive force (mmf), and no significant deterioration of magnetic strength over time are now common. Examples include ceramic ferrite magnets (Fe₂O₃); samarium cobalt (SmCO₅); combinations of iron, neodymium, and boron; and others.

Magnetic paths for transformers are often constructed of laminated ferrous materials; inductors often employ ferrite materials, which are used for higher frequency operation for both devices. High performance magnetic materials for use as the magnetic paths within a magnetic circuit are now available and are well suited for the (rapid) switching of magnetic flux with a minimum of eddy currents. An example is the FINEMET® nanocrystalline core material made by Hitachi of Japan.

According to Moskowitz, "Permanent Magnet Design and Application Handbook" 1995, page 52, magnetic flux may be thought of as flux lines which always leave and enter the surfaces of ferromagnetic materials at right angles, which never can make true right-angle turns, which travel only in straight or curved paths, which follow the shortest distance, and which follow the path of lowest reluctance.

A "reluctance switch" is a device that can significantly increase or decrease (typically increase) the reluctance (resistance to magnetic motive force) of a magnetic path in a direct and rapid manner and subsequently restore it to its original (typically lower) value in a direct and rapid manner. A reluctance switch typically has analog characteristics. By way of contrast, an off/on electric switch typically has a digital characteristic, as there is no electricity "bleed-through." With the current state of the art, reluctance switches have magnetic flux bleed-through. Reluctance switches may be implemented mechanically, such as to cause keeper movement to create an air gap, or electrically by several means, or by other means. One electrical means is that of using control coils wound around the flux paths.

Another electrical means is the placement within the flux path of certain classes of materials that change (typically increase) their reluctance upon the application of electricity. Another electrical means is to saturate a region of the switch material so that the reluctance increases to that of air by inserting conducting electrical wires into the material as described by Konrad and Brudny in "An Improved Method for Virtual Air Gap Length Computation," in IEEE Transactions on Magnetics, Vol. 41, No. 10, October 2005.

The patent literature describes a number of constructs that have been devised to vary the amounts of magnetic flux in alternate flux paths by disproportionately dividing the flux from a stationary permanent magnet or magnets between or among alternate flux paths repeatedly for the purpose of generating electricity. The increase of flux in one magnetic path and the corresponding decrease in the other path(s) provide the basis for inducing electricity when coils are wound around the paths. The physics involved for producing electricity by these constructs is described by the transformer equation $V = -\frac{dB}{dt} \cdot N \cdot A$. A variety of reluctance switching means have been employed to cause the flux to be increased/decreased through a particular alternate path with a corresponding decrease/increase in the other path and to do so repeatedly.

A means of switching flux along alternate paths between the opposite poles of a permanent magnet have included the flux transfer principle described by R. J. Radus, Engineers' Digest, July, 1963.

A result of providing alternate flux paths of generally similar geometry and permeability is that, under particular conditions, the alternate path first selected or the path selected for the majority of the flux will remain a "preferred path" in that it will retain more flux and the other path, despite the paths having equal reluctance. (There is not an automatic equalization of the flux among similar paths.)

Moskowitz, "Permanent Magnet Design and Application Handbook" 1995, page 87 discusses this effect with regard to the industrial use of permanent magnets to lift and release iron and steel by turning the permanent magnet on and (almost) off via reluctance switching that consists of the electric pulsing of coils wound around the magnetic flux paths (the reluctance switches).

Experimental results with four iron rectangular bars (relative permeability=1000) placed together in a square with a bar permanent magnet (flux density measured at one pole=5000 Gauss) between two of the opposing bars roughly in a centre position showed that removal and replacement of the one of the end bars that is parallel to the bar magnet will result in about 80% of the flux remaining in the bar that remained in contact. The results further showed that the preferred path must experience an increase of reluctance about 10x of that of the available alternate path before its disproportionate flux condition will yield and transfer to the alternate path.

Flynn U.S. Pat. No. 6,246,561; Patrick, et al. U.S. Pat. No. 6,362,718; and Pedersen U.S. Pat. No. 6,946,938 all disclose a method and apparatus for switching (dividing) the quantity of magnetic flux from a stationary permanent magnet or magnets between and among alternate paths for the purpose of generating electricity (and/or motive force). They provide for the increase of magnetic flux in one path with a corresponding decrease in the other path(s). There are always at least two paths.

SUMMARY OF THE INVENTION

The present invention relates to methods and apparatus for the production of electricity through the operation of a circuit based upon a single magnetic flux path. A magnetisable member provides the flux path. One or more electrically conductive coils are wound around the member, and a reluctance or flux switching apparatus is used to control the flux. When operated, the switching apparatus causes a reversal of the polarity (direction) of the magnetic flux of the permanent magnet through the member, thereby inducing alternating electrical current in each coil.

According to the invention, the flux switching apparatus may be motionless or rotational. In the motionless embodiments, four reluctance switches are operated by a control unit that causes a first pair of switches to open (increasing reluctance), while another pair of switches close (decreasing reluctance). The initial pair is then closed as the other pair is opened, and so on. This 2x2 opening and closing cycle repeats and, as it does, the magnetic flux from the stationary permanent magnet(s) is reversed in polarity through the magnetisable member, causing electricity to be generated in the conducting coils. An alternative motionless embodiment uses two reluctance switches and two gaps of air or other materials.

In alternative embodiments, the flux switching apparatus comprises a body composed of high-permeability and low-permeability materials, such that when the body is rotated, the flux from the magnet is sequentially reversed through the magnetisable member. In the preferred embodiment the body is cylindrical having a central axis, and the body rotates about the axis. The cylinder is composed of a high-permeability material except for section of low-permeability material that divided the cylinder into two half cylinders. At least one electrically conductive coil is wound around the magnetisable member, such that when the body rotates an electrical current is induced in the coil. The body may be rotated by mechanical, electromechanical or other forces.

A method of generating electrical current, comprises the steps of providing a magnetisable member with an electrically conductive coil wound therearound, and sequentially reversing the flux from a permanent magnet through the member, thereby inducing electrical current in the coil.

BRIEF DESCRIPTION OF THE DRAWINGS

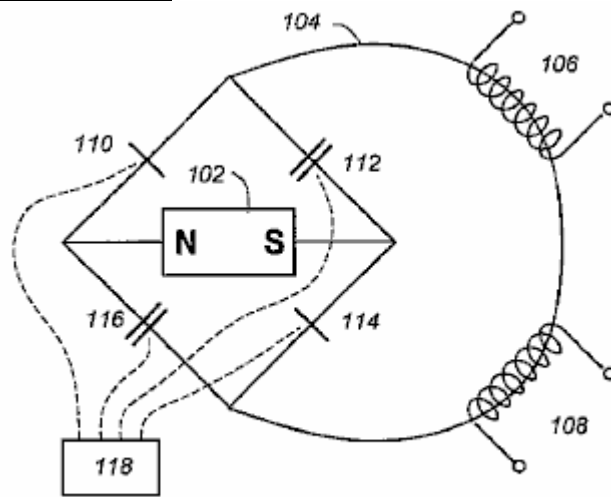

Fig - 1

Fig.1 is a schematic diagram of a magnetic circuit according to the invention.

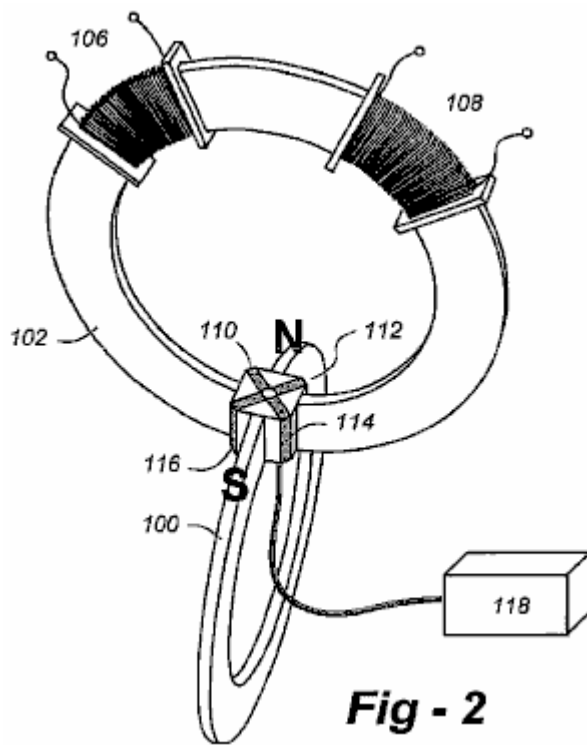

Fig - 2

Fig.2 is a perspective view of an embodiment of the invention based upon motionless magnetic flux switches.

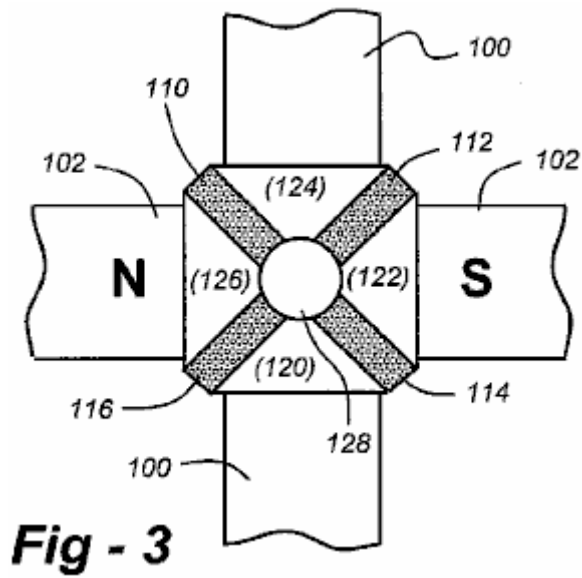

Fig.3 is a detail drawing of a motionless flux switch according to the invention.

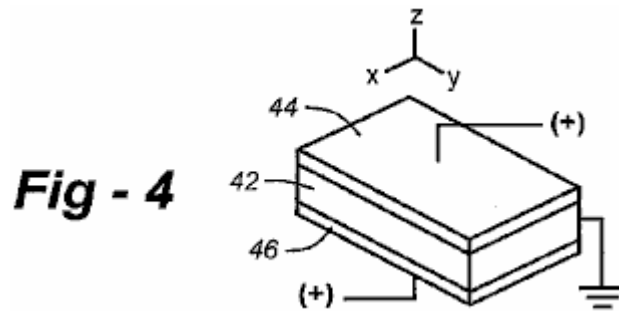

Fig.4 is a detail drawing of a reluctance switch according to the invention.

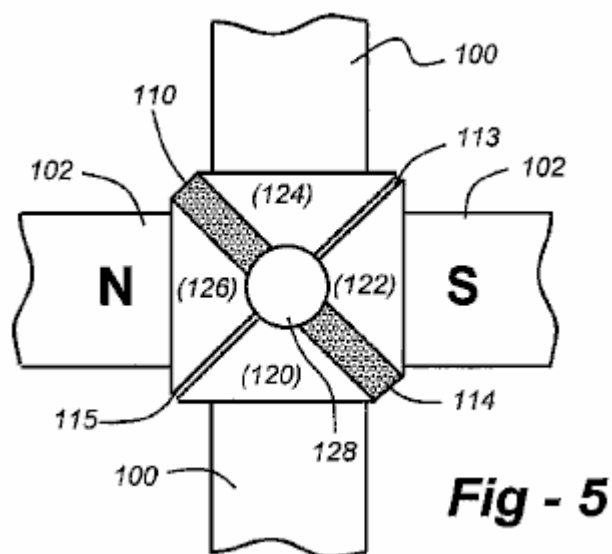

Fig.5 is a detail drawing of an alternative motionless flux switch according to the invention which utilizes gaps of air or other materials.

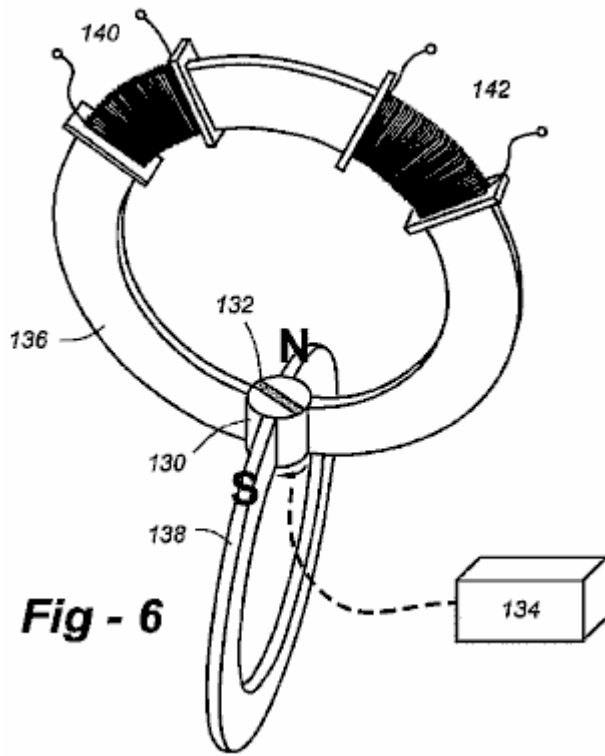

Fig.6 is a schematic diagram of a system using a rotary flux switch according to the invention.

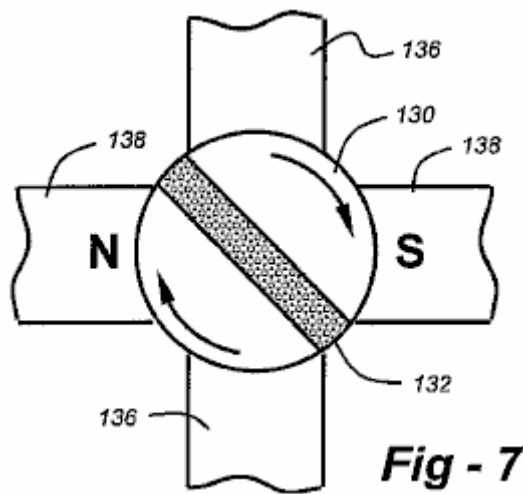

Fig.7 is a detail drawing of a rotary flux switch according to the invention.

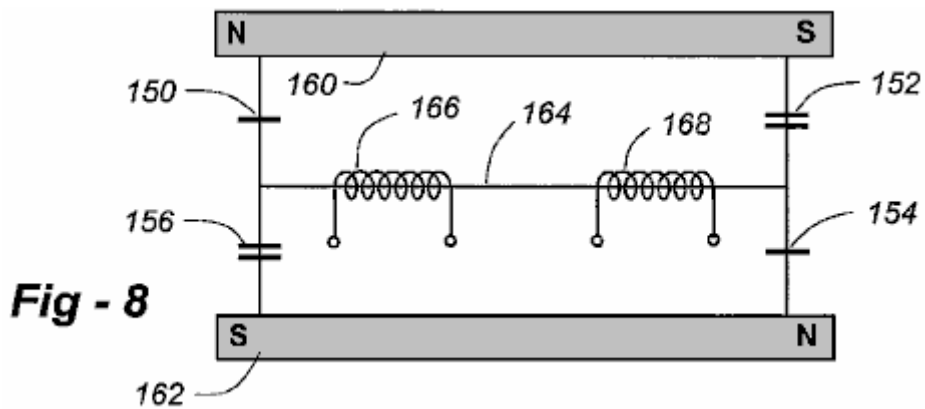

Fig.8 is a schematic diagram of a circuit according to the invention utilizing two permanent magnets and a single flux path.

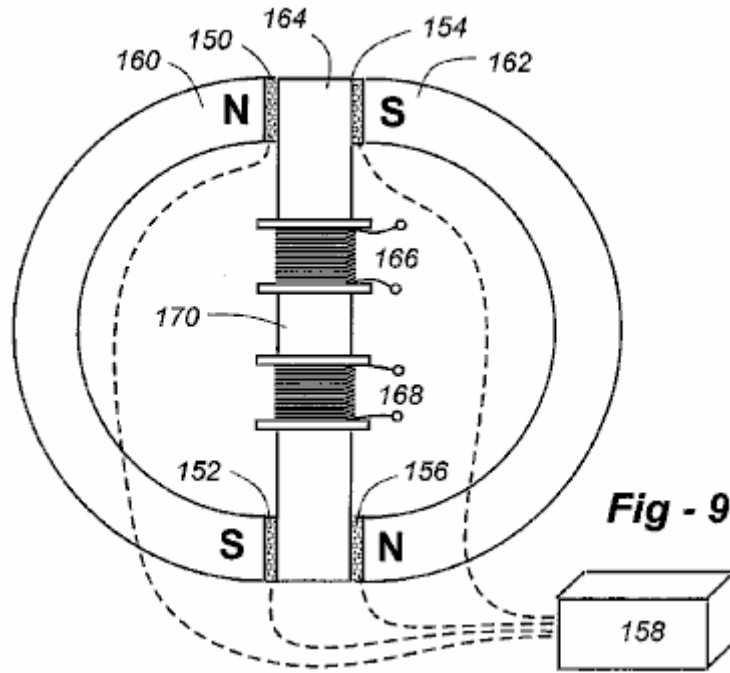

Fig.9 shows one possible physical embodiment of the apparatus with the components of FIG. 8, including a reluctance switch control unit.

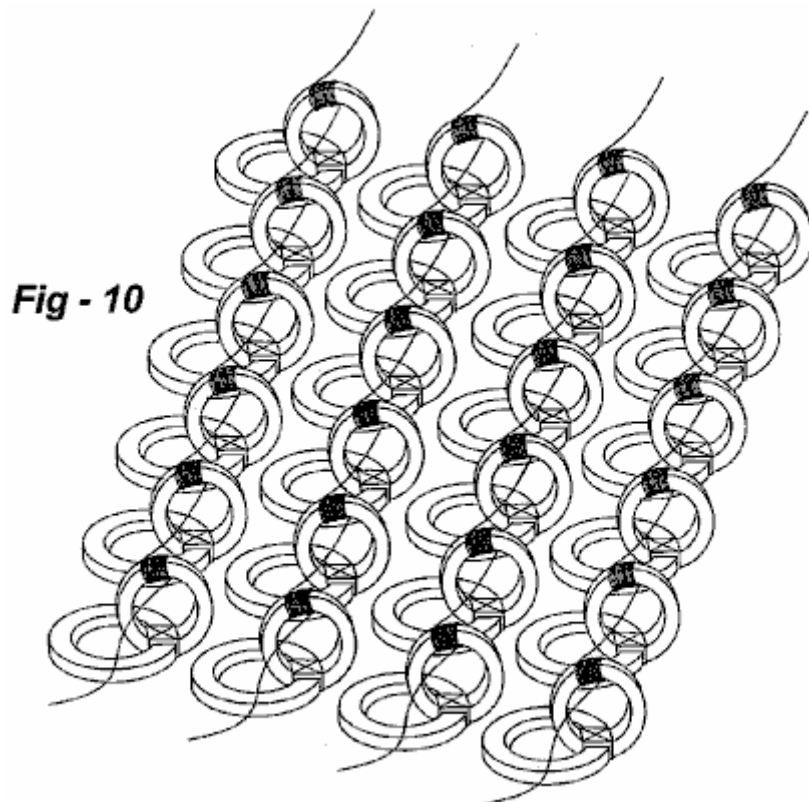

Fig.10 shows an array of interconnected electrical generators according to the invention.

DETAILED DESCRIPTION OF THE PREFERRED EMBODIMENTS

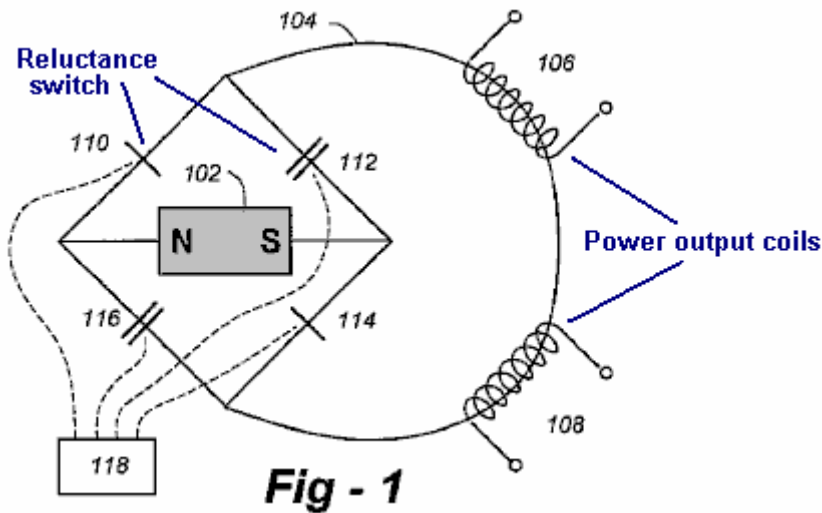

Fig.1 is a schematic diagram of a magnetic circuit according to the invention utilizing a motionless flux switch. The circuit includes the following components: a permanent magnet 102, single flux path 104, conducting coils 106, 108, and four reluctance switches 110, 112, 114, 116. Under the control of unit 118, reluctance switches 110, 114 open (increasing reluctance), while switches 112, 116 close (decreasing reluctance). Reluctance switches 110, 114 then close, while switches 112, 116 open, and so on. This 2x2 opening and closing cycle repeats and, as it does, the magnetic flux from stationary permanent magnet 102 is reversed in polarity through single flux path 104, causing electricity to be generated in conducting coils 106, 108.

An efficient shape of permanent magnet 102 is a "C" in which the poles are in close proximity to one another and engage with the flux switch. The single flux is carried by a magnetisable member 100, also in a "C" shape with ends that are in close proximity to one another and also engage with the flux switch. In this, and in other embodiments, the 2x2 switching cycle is carried out simultaneously. As such, control circuit 118 is preferably implemented with a crystal-controlled clock feeding digital counters, flip-flops, gate packages, or the like, to adjust rise time, fall time, ringing and other parasitic effects. The output stage of the control circuit may use FET (Field-Effect Transistor switches) to route analog or digital waveforms to the reluctance switches as required.

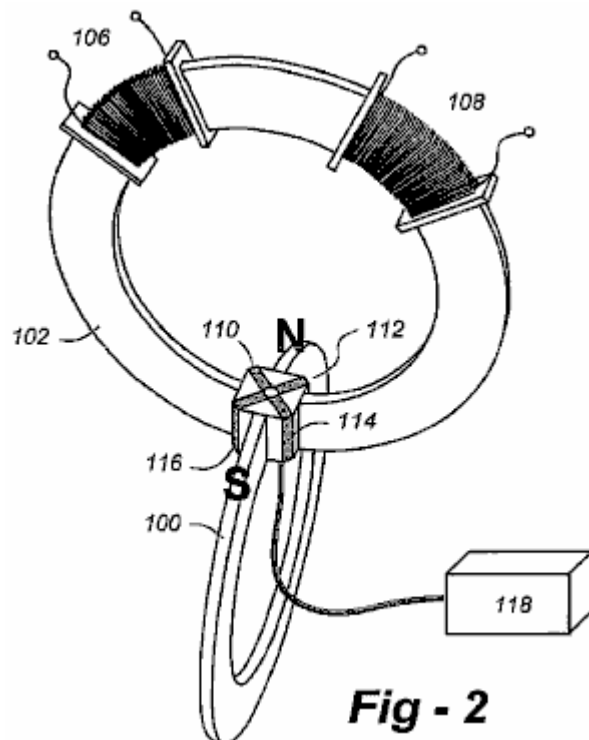

Fig.2 is a perspective of one possible physical embodiment of the apparatus using the components of Fig.1, showing their relative positions to one another. Reluctance switches 110, 112, 114, 116 may be implemented differently, as described below, but will usually occupy the same relative position within the apparatus.

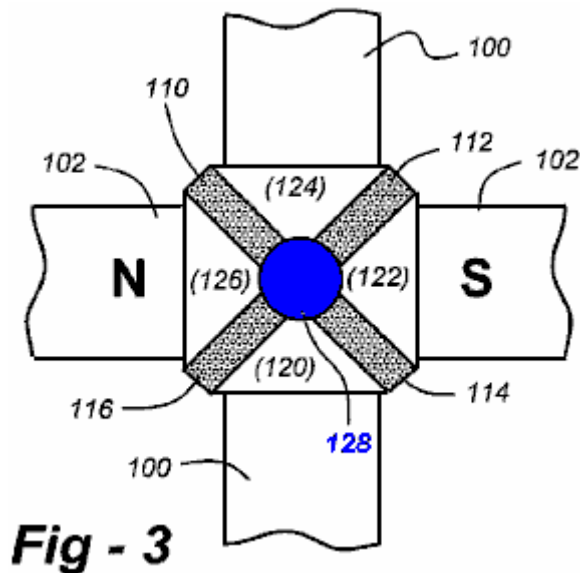
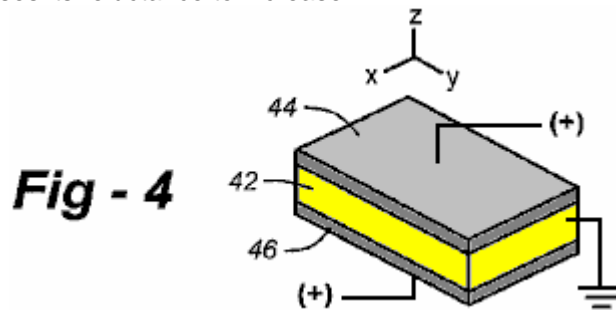

Fig.3 is a detail drawing of the motionless flux switch. Connecting segments 120, 122, 124, 126 must be made of a high-permeability ferromagnetic material. The central volume 128 may be a through-hole, providing an air gap, or it may be filled with glass, ceramic or other low-permeability material. A super-conductor or other structure exhibiting the Meissner effect may alternatively be used.

In the embodiment depicted in Fig.2 and Fig.3, reluctance switches 110, 112, 114, 116 are implemented with a solid-state structure facilitating motionless operation. The currently preferred motionless reluctance switch is described by Toshiyuki Ueno & Toshiro Higuchi, in the paper "Investigation on Dynamic Properties of Magnetic Flux Control Device composed of Lamination of Magnetostrictive Material Piezoelectric Material," The University of Tokyo 2004, the entirety of which is incorporated herein by reference. As shown in Fig.4, this switch is made of a laminate of a GMM (Giant Magnetostrictive Material 42), a TbDyFe alloy, bonded on both sides by a PZT (Piezoelectric) material 44, 46 to which electricity is applied. The application of electricity to the PZT creates strain on the GMM, which causes its reluctance to increase.



Other arrangements are applicable, including those disclosed in pending U.S. Patent Application Serial no. 2006/0012453, the entire content of which is incorporated herein by reference. These switches disclosed in this reference are based upon the magnetolectric (ME) effects of liquid crystal materials in the form of magnetostrictive and piezoelectric effects. The properties of ME materials are described, for example, in Ryu et al, "Magnetolectric Effect in Composites of Magnetostrictive and Piezoelectric Materials," Journal of Electroceramics, Vol. 8, 107-119

Filipov et al, "Magnetolectric Effects at Piezoresonance in Ferromagnetic-Ferroelectric Layered Composites," Abstract, American Physical Society Meeting (March 2003) and Chang et al., "Magneto-band of Stacked Nanographite Ribbons," Abstract, American Physical Society Meeting (March 2003). The entire content of each of these papers are also incorporated herein.

Further alternatives include materials that may sequentially heated and allowed to cool (or cooled and allowed to warm up or actively heated and cooled) above and below the Currie temperature, thereby modulating reluctance. Gadolinium is a candidate since its Currie point is near room temperature. High-temperature superconductors are other candidates, with the material being cooled in an insulated chamber at a temperature substantially at or near the Currie point. Microwave or other energy sources may be used in conjunction with the control unit to effectuate this switching. Depending upon how rigidly the switches are contained, further expansion-limiting 'yokes' may or may not be necessary around the block best seen in Fig.4.

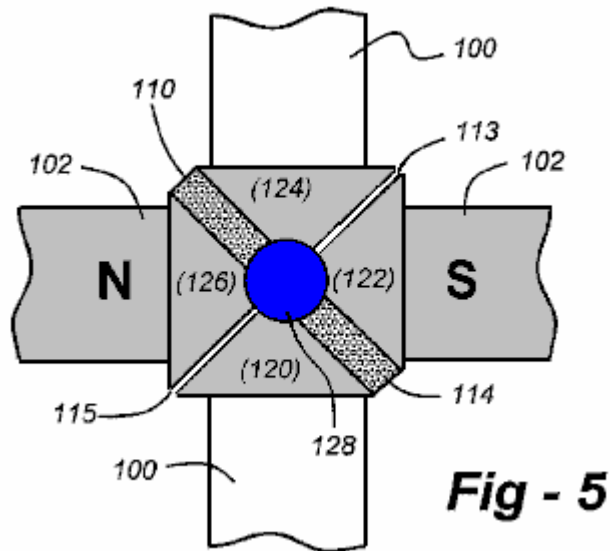

Fig - 5

Fig.5 is a detail drawing of an alternative motionless flux switch according to the invention which utilizes gaps of air or other materials. This embodiment uses two electrically operated reluctance switches 110, 114, and two gaps 113, 115, such that when the switches are activated in a prescribed manner, the flux from the magnet 102 is blocked along the switch segments containing the switches and forced through the gap-containing segments, thereby reversing the flux through the magnetisable member 100. Upon activation of the two reluctance switches 110, 114, the flux, seeking a path of significantly lower reluctance, flips back to the original path containing the (non deactivated) reluctance switches, thereby reversing the flux through the member 100. Note that the flux switches may also be electromagnetic to saturate local regions of the switch such that reluctance increases to that of air (or gap material), creating a virtual gap as described by Konrad and Brudny in the Background of the Invention.

More particularly, flux switching apparatus according to this embodiment uses a permanent magnet having a north pole 'N' and a south pole 'S' in opposing relation across a gap defining a volume. A magnetisable member with ends 'A' and 'B' is supported in opposing relation across a gap sharing the volume, and a flux switch comprises a stationary block in the volume having four sides, 1-4, with two opposing sides interfaced to N and S, respectively and with the other two opposing sides being interfaced to A and B, respectively. The block is composed of a magnetisable material segmented by two electrically operated magnetic flux switches and two gaps filled with air or other material(s). A control unit in electrical communication with the flux switches is operative to:

- a) passively allow a default flux path through sides 1-2 and 3-4, then
- b) actively establish a flux path through sides 2-3 and 1-4, and
- c) repeat a) and b) on a sequential basis.

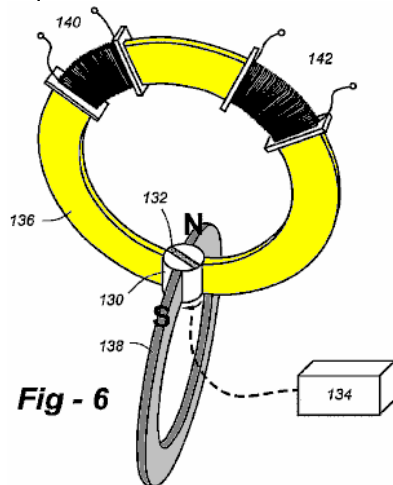

Fig - 6

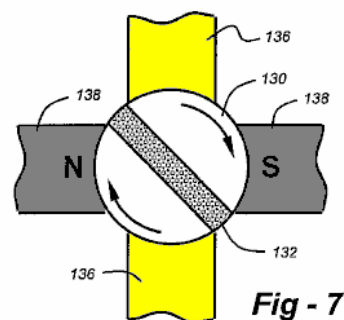

Fig - 7

As an alternative to a motionless flux switch, a rotary flux switch may be used to implement the 2x2 alternating sequence. Referring to Fig.6 and Fig.7, cylinder 130 with flux gap 132 is rotated by a motive means 134. This causes the halves of cylinder 130 to provide two concurrent and separate magnetic flux bridges (i.e., a "closed" reluctance switch condition), in which a given end of magnetisable member 136 is paired up with one of the poles

of stationary permanent magnet 138. Simultaneously, the other end of single flux path carrier 136 is paired up with the opposite pole of stationary permanent magnet 138.

Fig.7 is a detail view of the cylinder. Each 90° rotation of the cylinder causes the first flux bridges to be broken (an "open" reluctance switches condition) and a second set of flux bridges to be created in which the given end of member 136 is then bridged with the opposite pole of stationary permanent magnet 138. A full rotation of cylinder 130 causes four such reversals. Each flux reversal within single flux path 2 causes an electric current to be induced in conducting coil(s) 140, 142. In this embodiment, it is important to keep a precise, consistent spacing between each of the "halves" of (rotating) cylinder 130 in relation to the poles of permanent magnet 138 and the ends of flux path carrier 136 as the magnetic flux bridges are provided by the cylinder 130 as it rotates.

Rotating cylinder 130 is made of high magnetic permeability material which is divided completely by the flux gap 132. A preferred material is a nanocrystalline material such as FINEMET® made by Hitachi. The flux gap 132 may be air, glass, ceramic, or any material exhibiting low magnetic permeability. A superconductor or other structure exhibiting the Meissner effect may alternatively be used.

An efficient shape of magnetisable member 136 is a "C" in which its opposing ends are curved with a same radius as cylinder 130 and are in the closest possible proximity with rotating cylinder 130. Permanent magnet 138 is also preferably C-shaped in which the opposing poles are curved with a same radius as cylinder 130 and are in the closest possible proximity with rotating cylinder 130. Manufacturing and assembly considerations may dictate other shapes.

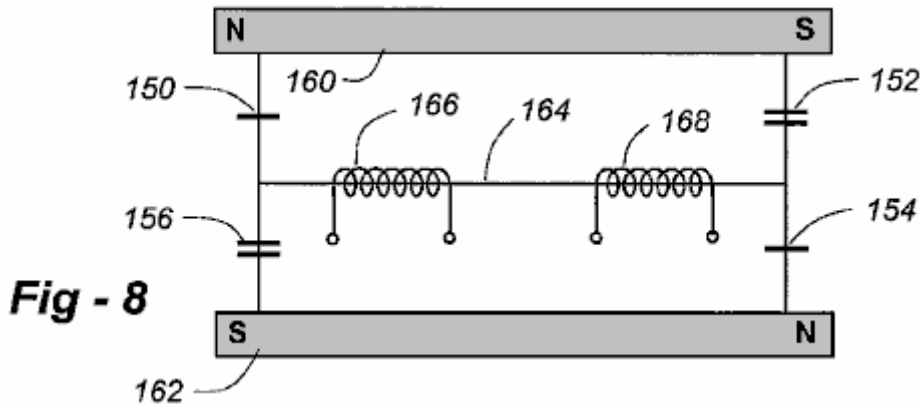

While the embodiments described thus far utilize a single permanent magnet, other embodiments are possible according to the invention utilizing a plurality of permanent magnets while nonetheless generating a single flux path. Fig.8 depicts a circuit utilizing two permanent magnets and a single flux path. Fig.9 shows one possible physical embodiment of the apparatus based upon the components of Fig.8, including a reluctance switch control unit 158.

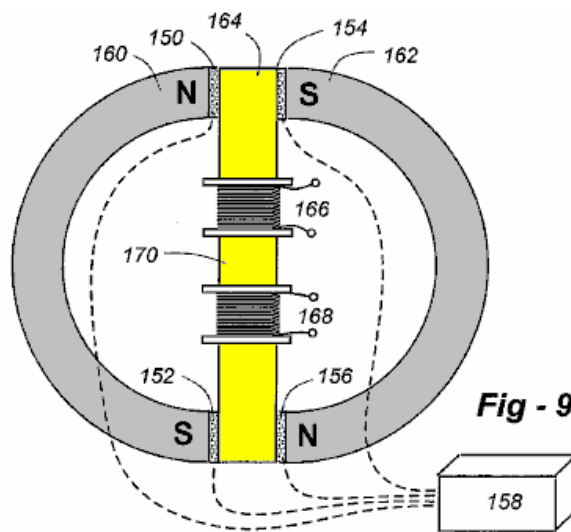

Under the control of unit 158, reluctance switches 150, 152 open (increasing reluctance), while switches 154, 156 close (decreasing reluctance). Reluctance switches 150, 152 then close, while switches 154, 156 open, and so on. This 2x2 opening and closing cycle repeats and, as it does, the magnetic flux from stationary permanent magnets 160, 162 is reversed in polarity through the magnetisable member, causing electricity to be generated in conducting coils 166, 168.

In the preferred implementation of this embodiment, the magnets are arranged with their N and S poles reversed. The magnetisable member is disposed between the two magnets, and there are four flux switches, SW1-SW4, two between each end of the member and the poles of each magnet. The reluctance switches are implemented with the structures described above with reference to Figs. 1 to 3.

For added particularity, assume the first magnet has north and south poles, N1 and S1, the second magnet has north and south poles, N2 and S2 and the member has two ends A and B. Assuming SW1 is situated between N1 and A, SW2 is between A and S2, SW3 is between N2 and B, and SW4 is between B and S1, the control circuitry operative to activate SW1 and SW4, then activate SW2 and SW3, and repeat this process on a sequential basis. As with the other embodiments described herein, for reasons of efficiency, the switching is carried out simultaneously.

In all of the embodiments described herein the material used for the permanent magnet(s) may be either a magnetic assembly or a single magnetized unit. Preferred materials are ceramic ferrite magnets (Fe_2O_3), samarium cobalt (SmCO_5), or combinations of iron, neodymium, and boron. The single flux path is carried by a material having a high magnetic permeability and constructed to minimize eddy currents. Such material may be a laminated iron or steel assembly or ferrite core such as used in transformers. A preferred material is a nanocrystalline material such as FINEMET®. The conducting coil or coils are wound around the material carrying the single flux path as many turns as required to meet the voltage, current or power objectives. Ordinary, standard, insulated, copper magnet wire (motor wire) is sufficient and acceptable. Superconducting materials may also be used. At least some of the electricity induced in the conducting coils may be fed back into the switch control unit. In this mode of operation, starting pulses of electricity may be provided from a chemical or solar battery, as required.

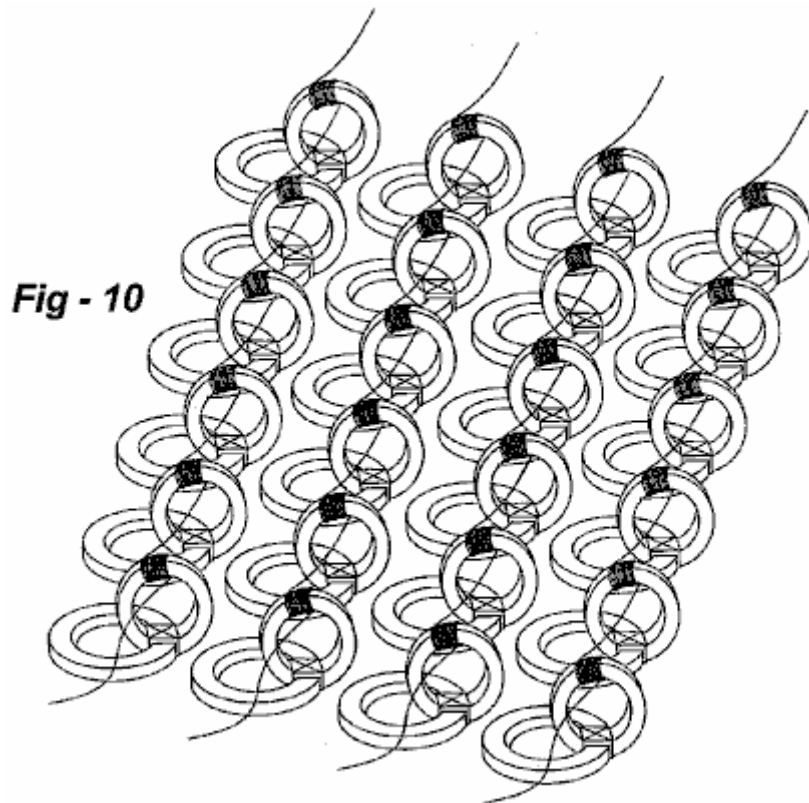

Although in the embodiments of Fig.2 and Fig.6 the magnet and flux-carrying materials are flat elements lying in orthogonal planes with flux-carrying material lying outside the volume described by the magnet, the flux path may be disposed 'within' the magnet volume or configured at an angle. The physical scale of the elements may also be varied to take advantage of manufacturing techniques or other advantages. Fig.10, for example, shows an array of magnetic circuits, each having one or more coils that may be in series, parallel, or series-parallel combinations, depending upon voltage or current requirements. In each case the magnets may be placed or fabricated using techniques common to the microelectronics industry. If mechanical flux switches are used they may be fabricated using MEMs-type techniques. If motionless switches are used, the materials may be placed and/or deposited. The paths are preferably wound in advance then picked and placed into position as shown. The embodiment shown in Fig.9 is also amenable to miniaturization and replication.

CLAIMS

1. An energy generator, comprising: at least one permanent magnet generating flux; a magnetisable member; an electrical conductor wound around the member; and a plurality of magnetic flux switches operative to sequentially reverse the flux from the magnet through the member, thereby inducing electricity in the electrical conductor.
2. The energy generator of claim 1, comprising: first and second loops of magnetisable material; the first loop having four segments in order A, 1, B, 2; the second loop having four segments in order C, 3, D, 4; the magnetisable member coupling segments 2 and 4; the permanent magnet coupling segments 1 and 3, such that the flux from the magnet flows through segments A, B, C, D and the magnetisable member; four magnetic flux switches, each controlling the flux through a respective one of the segments A, B, C, D; and a controller operative to activate switches A-D and B-C in an alternating sequence, thereby reversing the flux through the segment and inducing electricity in the electrical conductor.
3. The energy generator of claim 2, wherein the loops and magnetisable member are composed of a nanocrystalline material exhibiting a substantially square BH intrinsic curve.
4. The energy generator of claim 2, wherein each magnetic flux switch is operative to add flux to the segment it controls, thereby magnetically saturating that segment when activated.
5. The energy generator of claim 2, wherein: each segment has an aperture formed therethrough; and each magnetic flux switch is implemented as a coil of wire wound through one of the apertures.
6. The energy generator of claim 2, wherein the controller is at least initially operative to activate the switches with electrical current spikes.
7. The energy generator of claim 2, wherein the first and second loops are toroids.
8. The energy generator of claim 2, wherein the first and second loops are spaced apart from one another, with A opposing C, 1 opposing 3, B opposing D and 2 opposing 4.
9. The energy generator of claim 2, wherein the first and second loops intersect to form the magnetisable member.
10. The energy generator of claim 2, wherein the flux flowing through each segment A, B, C, D is substantially half of that flowing through the magnetisable member prior to switch activation.

The Energy Conversion Device of William McDavid junior

US Patent 6,800,955

5th Oct. 2004

Inventor: William McDavid jnr.

Fluid-powered energy conversion device

Note: The wording of this patent has been altered to make it easier to understand. An unaltered copy can be downloaded from www.freepatentsonline.com. In this patent, William relates sections of his design according to the direction of flow through the housing and so he calls the first section the "downstream" chamber and the following chamber as the "upstream" chamber. Although water could be used, this patent essentially describes a high-efficiency wind-powered generator. For dimensions: one inch = 25.4 mm.

Abstract:

A fluid-powered energy conversion device which converts energy in a moving fluid into mechanical energy. A rigid cylindrical frame of toroidal baffles forms an "upstream" annular or ring-shaped chamber and a "downstream" annular chamber, each of the chambers having open sides to allow the entry of the fluid. The toroidal baffles create an upstream **drive** vortex in an upstream central vortex chamber, and a downstream **extraction** vortex rotating in the opposite direction in a downstream central vortex chamber. A set of hinged louvers surround the vortex chambers and these allow the fluid to enter each chamber only in the direction of vortex rotation, and prevent the fluid from exiting through the sides of the device. The driving vortex passes through, and rotates, a turbine positioned in a central aperture between the two chambers. The turbine blades are rotated by the rotational momentum of the driving fluid vortex, plus the lift generated by each turbine blade, plus the additional momentum imparted by the vortex reversal.

US Patent References:

McDavid, Jr. – US 6,710,469

McDavid, Jr. – US 6,518,680

Walters – US 5,664,418

Description:

BACKGROUND OF THE INVENTION

1. Technical Field of the Invention

The present invention relates generally to electrical generation and energy conversion devices, and more particularly to a fluid-powered energy conversion device which converts the energy of wind or flowing water into mechanical or electrical energy.

2. Description of Related Art

The use of wind or flowing water to provide power for various uses dates back many centuries. In modern times, wind and water have been used to generate electricity. Hydroelectric generating plants have been used to generate large quantities of electrical energy for widespread distribution. However, this requires major permanent environmental changes to the areas where dams are built and reservoirs rise. Wind-powered devices, in general, have been used to perform mechanical work, or to generate electricity, only on a limited scale. With the ever increasing demand for additional, or alternative energy sources, all possible sources are being given more scrutiny. This is particularly true for sources which are non-polluting and inexhaustible. Free-flowing hydroelectric and wind-powered systems provide such sources, and the capturing of increased energy from wind and water has received much consideration.

However, commercial hydro-electric and wind-powered electrical generation devices which are currently in use have several disadvantages. Wind-powered devices, in particular, are expensive, inefficient, dangerous, noisy, and unpleasant to be around. To capture a large volume of wind, existing wind-powered devices are very large. As a result, they cannot be distributed throughout population centres, but must be installed some distance away. Then, like dams with hydro-electric generators, the electrical energy they generate must be transmitted, at considerable cost and with considerable energy loss, to the population centres where the energy is needed.

It would be desirable to distribute smaller water-powered and wind-powered units throughout the population centres. For example, it would be desirable to have a wind-powered unit for each building structure, thus distributing the generating capacity over the entire area, and making the energy supply less vulnerable to local

events such as storms or earthquakes. Such distributed generation would also solve the most common and valid objection to wind power, namely, that the wind does not blow all the time. In a large geographical area, however, wind is almost always blowing somewhere. Therefore, with wind-powered generators which are distributed throughout the area, power could be generated in the areas where the wind is blowing, and then transmitted to the rest of the power grid. However, with existing technology, smaller units suitable for distributing throughout a population area are not efficient enough to provide a sufficient amount of energy to power a structure such as a house or office building. In addition, such units are visually obtrusive and noisy, making them unsuitable for use in residential or other highly populated settings.

Existing wind-powered electrical generation devices commonly utilise a propeller mounted on the horizontal shaft of a generator which, in turn, is mounted at the top of a tower. This is an inefficient design because energy is extracted from the wind by reducing the wind velocity as it passes through the propeller. This creates a pocket of slow-moving air cantered behind the propeller, which the ambient wind blows around. Therefore, only the outer portion of the propeller blades use the wind efficiently.

To counter this effect, modern windmill designs utilise extremely long propeller blades. The use of such massive blades, however, has its own disadvantages. Firstly, the propellers are known to kill or injure thousands of large birds each year. Secondly, the massive blades can be dangerous if the device fails structurally and the propeller breaks loose. In this case, the propeller can fly a considerable distance and cause serious damage or injury to anything or anyone in its path. Thirdly, the propeller design contains an inherent gravitational imbalance. The rising blades on one side of the propeller's hub are opposing gravity, while the descending blades on the other side of the hub are falling with gravity. This imbalance creates a great deal of vibration and stress on the device. Consequently, the device must be structurally enhanced, at great expense, to withstand the vibration and stress, and thus avoid frequent maintenance and/or replacement.

It would therefore be advantageous to have a fluid-powered energy conversion device which overcomes the shortcomings of existing devices. Such a device could utilise wind energy or the energy of flowing water to provide mechanical energy or electrical energy. The present invention provides such a device.

SUMMARY OF THE INVENTION

One aspect, the present invention is a fluid-powered energy-conversion device for converting energy in a moving fluid into mechanical energy. The device includes a rigid cylindrical frame which has an "upstream" annular (ring-shaped) chamber and a "downstream" annular chamber. Each of the chambers has sides which are open to allow entry of the moving fluid. A first set of baffles are mounted longitudinally in the upstream chamber, and these create a driving vortex which rotates in a first direction when the moving fluid enters the upstream chamber through the upstream chamber's open sides. A set of hinged louvers are positioned in the openings between these baffles, creating a central vortex chamber centered on the longitudinal axis of the device.

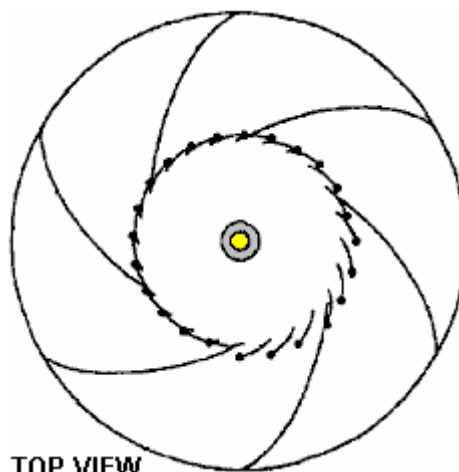

This first set of louvers permits entry of the moving fluid into the upstream central vortex chamber only when the fluid is rotating in the first direction. They also prevent the fluid from exiting from the upstream central vortex chamber through the sides of the device. The device also includes a floor of the upstream annular chamber which slopes upwards towards the downstream chamber as the floor approaches the central longitudinal axis of the device.

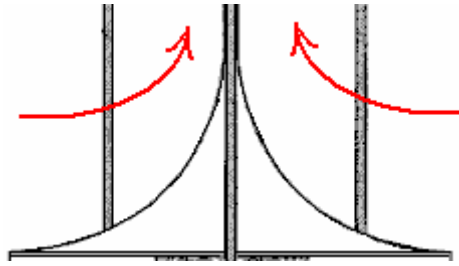

This sloping floor causes the drive vortex to flow “downstream” (upwards for air) through the upstream central vortex chamber and pass through a central aperture located between the upstream annular chamber and the downstream annular chamber. A longitudinal drive shaft is mounted centrally in the central aperture, and a turbine is mounted on the drive shaft in the central aperture. The turbine is rotated by the drive vortex as the drive vortex passes through the central aperture.

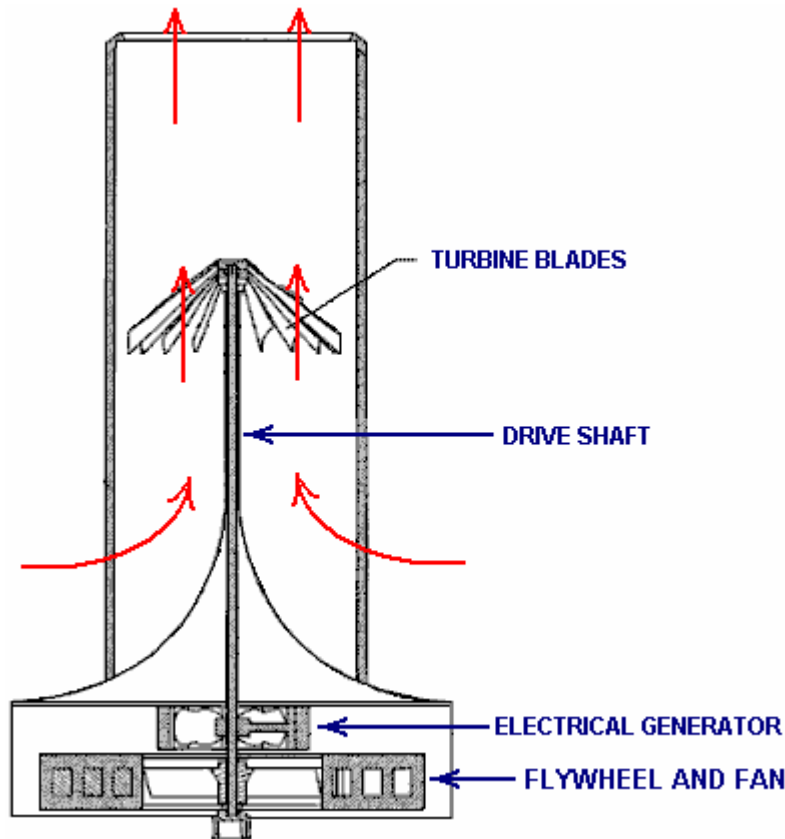

The device may also include a second set of baffles longitudinally mounted in the “downstream” (upper for air) chamber which operate to create an extraction vortex which rotates in the opposite direction when the moving fluid enters the downstream chamber through the downstream chamber's open sides. Additionally, a second set of hinged louvers may be positioned in the openings between the second set of baffles, encircling a downstream central vortex chamber. The second set of louvers permit entry of the moving fluid into the downstream central vortex chamber only when the fluid is rotating in the direction opposite to the direction of flow in the “upstream” chamber. These louvers also prevent the fluid from exiting the downstream central vortex chamber through the sides of the device. In this manner, the turbine is rotated by the drive vortex as the drive vortex passes through the turbine and reverses direction to match the direction of the extraction vortex.

For high-wind conditions or when powered by water flow, the driving vortex and extraction vortex may rotate in the same direction. The first set of hinged louvers form the upstream central vortex chamber, and the second set of hinged louvers form the downstream central vortex chamber. The first set of louvers permit entry of the wind or water into the upstream central vortex chamber only when the fluid is rotating in the first direction.

BRIEF DESCRIPTION OF THE DRAWINGS

The invention will be better understood and its numerous objects and advantages will become more apparent to those skilled in the art by reference to the following drawings, in conjunction with the accompanying specification, in which:

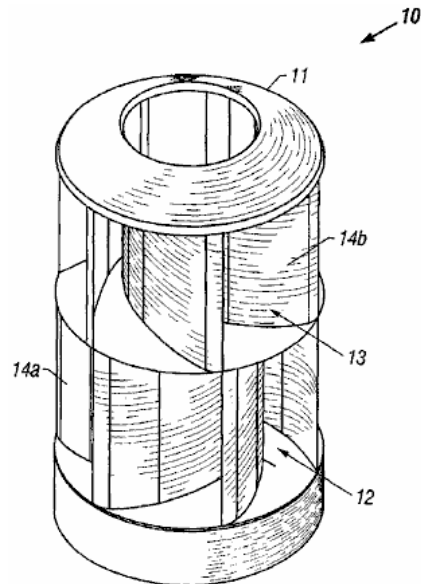

FIG. 1

FIG.1 is a perspective view of a first embodiment of the present invention that converts wind energy to mechanical or electrical energy;

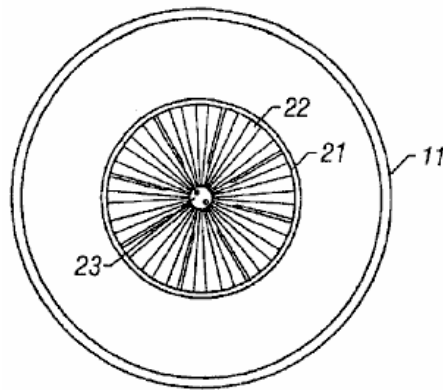

FIG. 2

FIG.2 is a top plan view of the embodiment of Fig.1

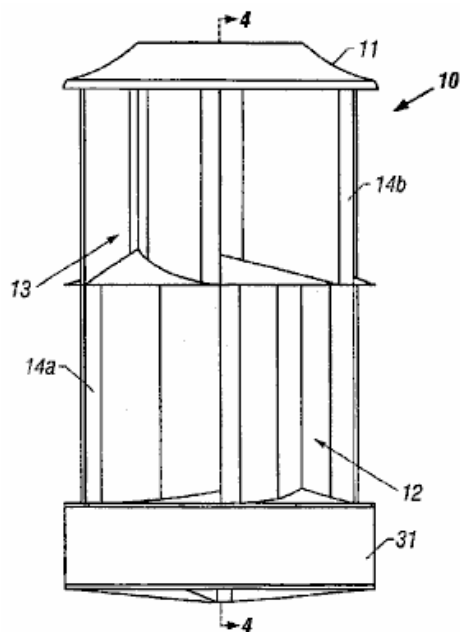

FIG. 3

FIG.3 is a side elevational view of the embodiment of Fig.1

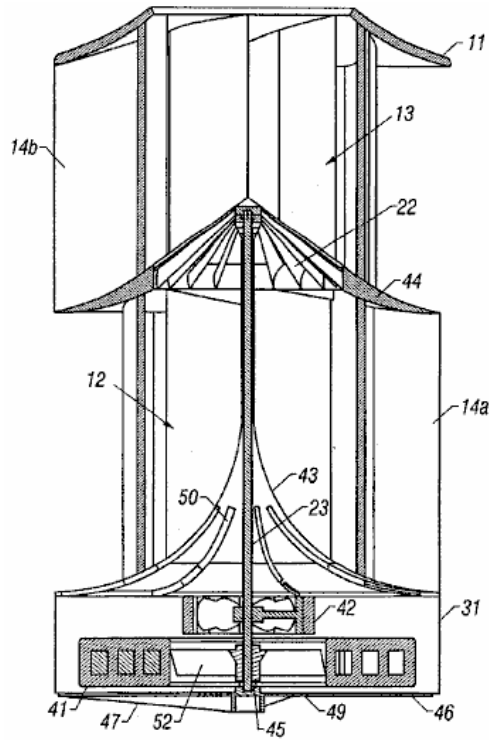

FIG. 4

FIG.4 is a cross-sectional view of the embodiment of Fig.1 taken along line 4 — 4 of Fig.3 with an electrical generator installed to produce electrical energy;

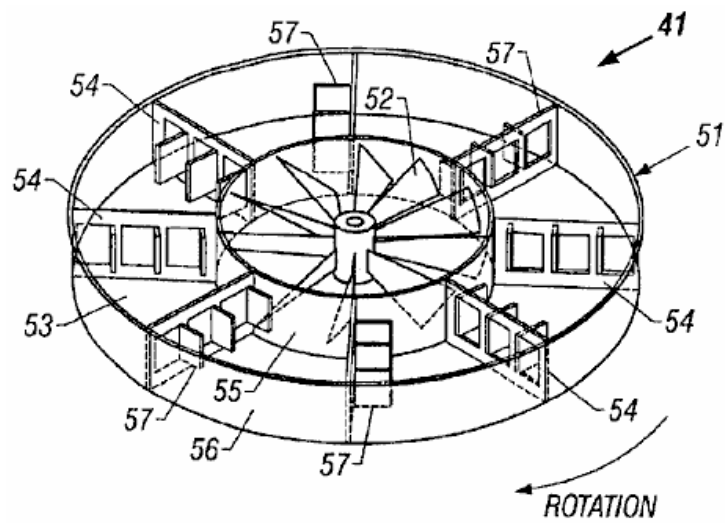

FIG. 5

FIG.5 is a perspective view of a fluid-filled flywheel suitable for use with the present invention;

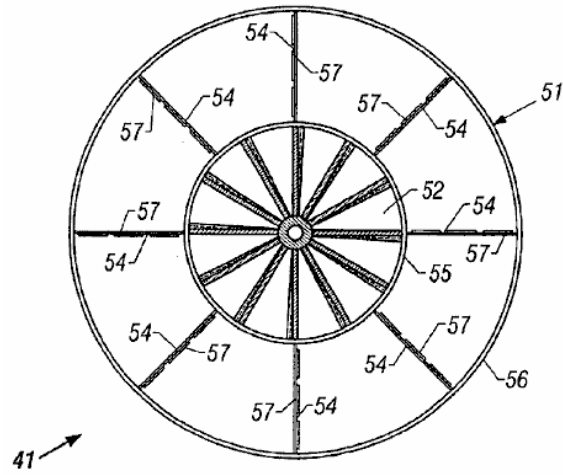

FIG. 6

FIG.6 is a top plan view of the fluid-filled flywheel of Fig.5

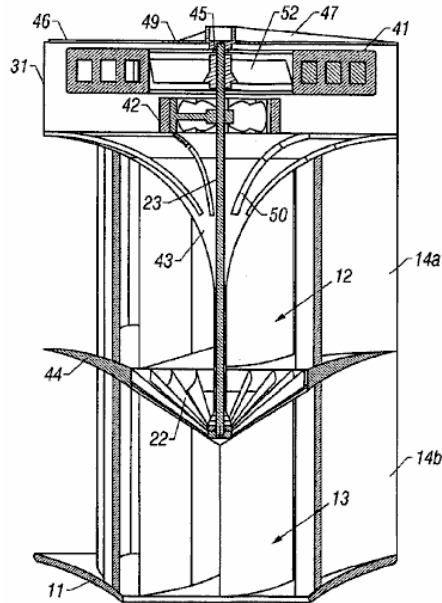

FIG. 7

FIG.7 is a cross-sectional view of an embodiment of the present invention that converts the energy of flowing water to electrical energy;

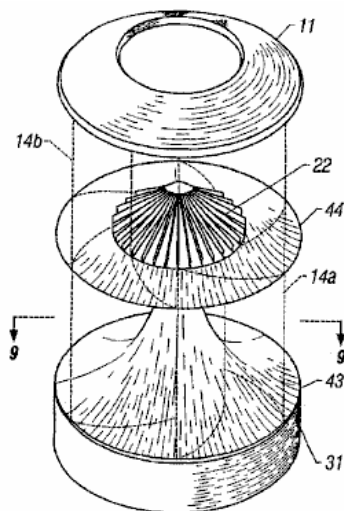

FIG. 8

FIG.8 is a perspective view of the embodiment of Fig.1 with the longitudinal baffles drawn in phantom so that the annular central divider (mid-deck) and turbine can be seen

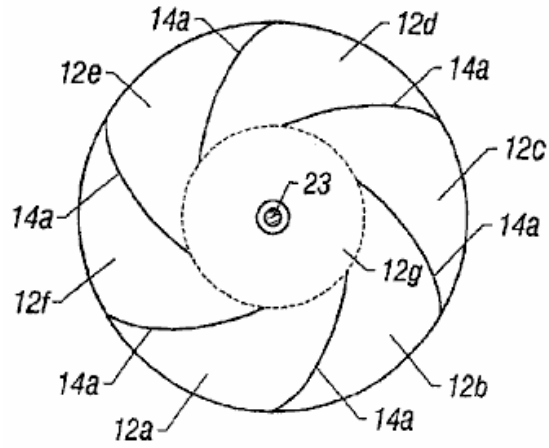

FIG. 9

FIG.9 is a horizontal cross-sectional view of the embodiment of Fig.1 taken along line 9 — 9 of Fig.8

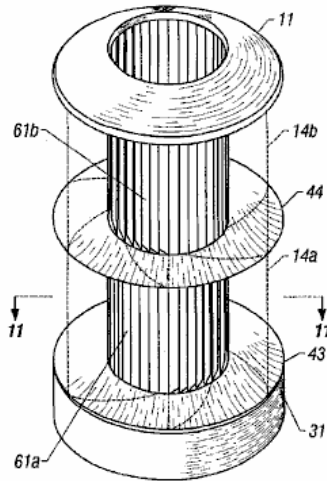

FIG. 10

FIG.10 is a perspective view of a second embodiment of the present invention that converts wind energy to mechanical or electrical energy, with the longitudinal baffles drawn in phantom so that a set of hinged longitudinal louvers can be seen; and

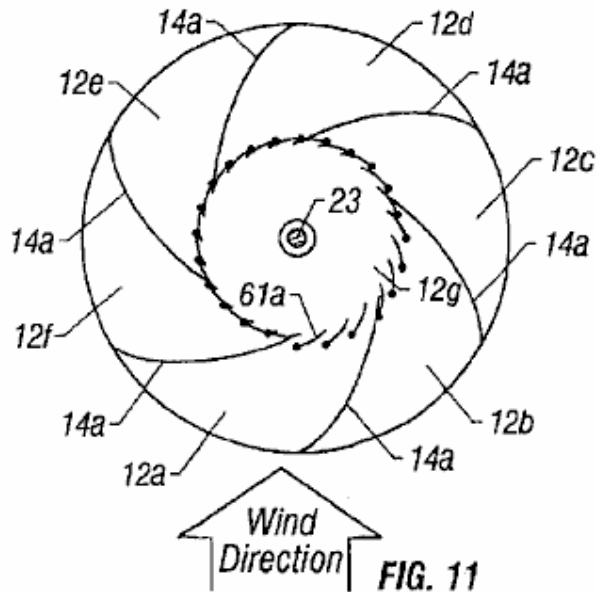

FIG. 11

FIG.11 is a horizontal cross-sectional view of the embodiment of Fig.10 taken along line 11 — 11 .

In the drawings, like or similar elements are designated with identical reference numerals throughout the various views, and the various elements shown are not necessarily drawn to scale.

DETAILED DESCRIPTION OF EMBODIMENTS

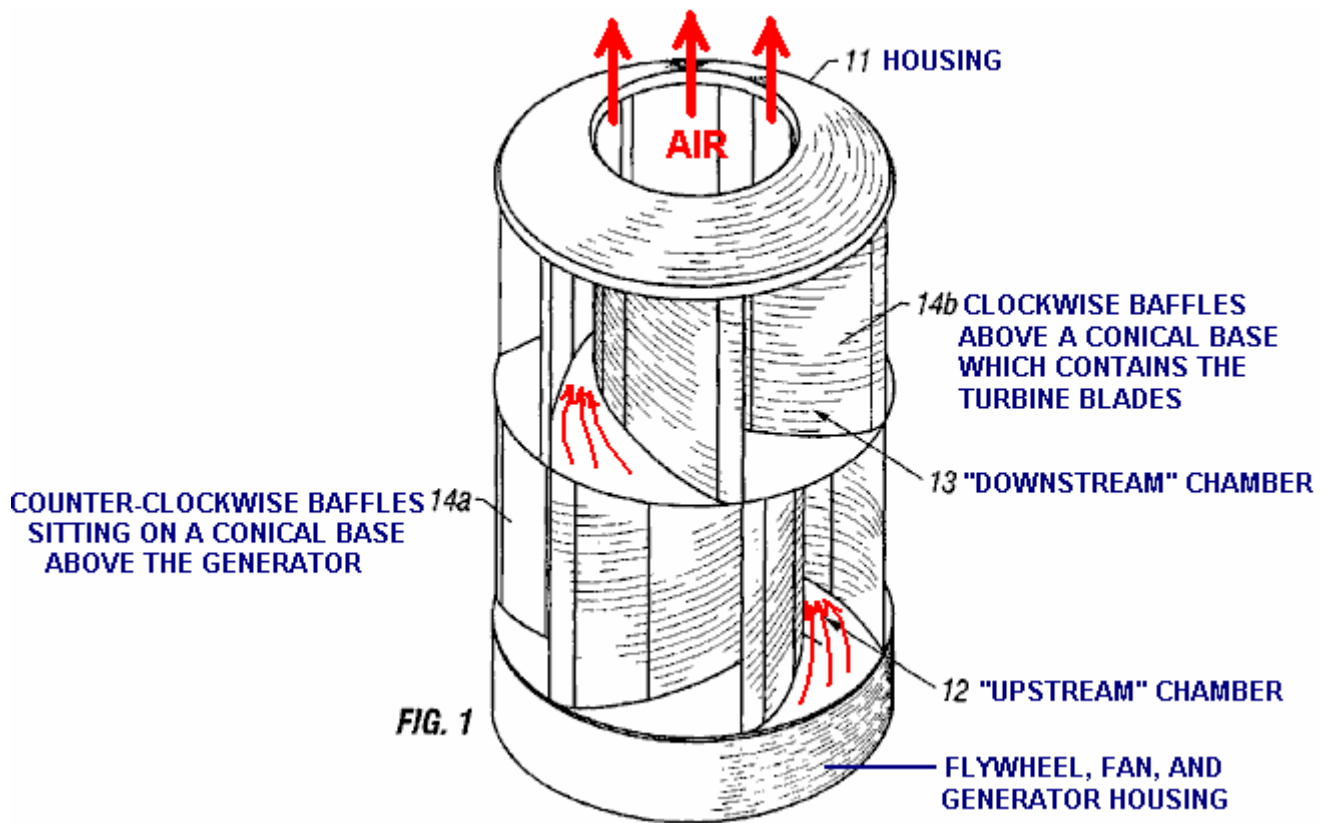

Fig.1 is a perspective view of an embodiment of the present invention which converts wind energy to mechanical or electrical energy. The energy conversion device **10** includes a stationary cowling **11** surrounding an upstream (lower) ring-shaped or doughnut-shaped chamber **12** and a downstream (upper) ring-shaped chamber **13**. The cowling may be constructed of any suitable rigid material such as wood, plastic, metal, or similar. The cowling may be constructed from a transparent material, making the device visually unobtrusive. In the preferred embodiment of the present invention, the cowling is cylindrical and is constructed of a high-grade, ultraviolet-protected plastic.

The cowling **11** includes a set of longitudinal baffles which are curved and arranged in a toroidal pattern. Upstream baffles **14a** are mounted in the upstream annular chamber **12**, and downstream baffles **14b** are mounted in the downstream annular chamber **13**. In the preferred embodiment of the present invention, approximately six toroidal longitudinal baffles are mounted in each chamber. The baffles function to guide the wind into each chamber. The narrowing cross-sectional area between the baffles causes the air to accelerate as it moves toward the centre of the device, creating two high-velocity vortices (an upstream drive vortex and a downstream extraction vortex). Although the invention is described here primarily as a vertically-oriented cylinder, it should be understood that the device may be installed in other positions, such as a horizontal orientation, which results in the device having an upstream annular chamber and a downstream annular chamber which are at the same height. Alternatively, as noted below in connection with **Fig.7**, the device may be inverted when used in water since water vortices move more readily downwards rather than upwards.

In the embodiment illustrated in **Fig.1**, in which low-speed wind is the input energy source, the upstream baffles **14a** and the downstream baffles **14b** are curved in opposite directions. The baffles therefore create two high-velocity vortices which rotate in opposite directions. As described below in connection with **Fig.4**, the direction of the vortex flow is reversed in a turbine located between the upstream annular chamber **12** and the downstream annular chamber **13**, thereby adding additional rotational power to the turbine. In the hydro-electrical embodiment in which flowing water is the input energy source, and in high-speed wind conditions such as when the device is mounted on a vehicle, the upstream baffles and the downstream baffles may be curved in the same direction. In those particular embodiments, therefore, the baffles create two high-velocity vortices which rotate in the same direction. The device may be converted from a low-wind device to a high-wind device by removing the counter-

rotational downstream annular chamber 13 and replacing it with a downstream annular chamber which creates a vortex rotating in the same direction as the drive vortex.

In the preferred embodiment of the present invention, plastic mesh (not shown) may surround the entry and exit openings of the cowling 11 to prevent birds, animals, or debris from entering the device 10. In addition, should the device fail structurally, any broken parts are contained by the mesh instead of flying out into the vicinity and causing damage or injury.

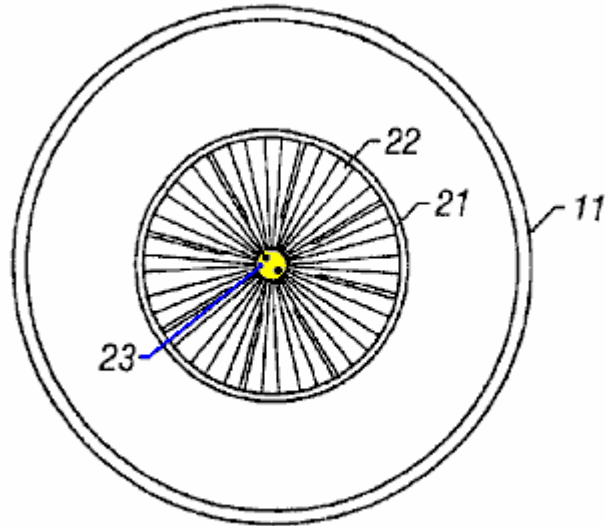

FIG. 2

Fig.2 is a top plan view of the embodiment of Fig.1. The top of the cowling 11 includes a central aperture 21 through which the air in the extraction vortex exits the device. In the preferred embodiment, the extraction vortex exits the device rotating in a counter-cyclonic direction (clockwise in the Northern Hemisphere) so that it dissipates rather than creating potentially damaging whirlwinds. The turbine 22 is visible through the aperture. The turbine rotates around a central drive shaft 23 .

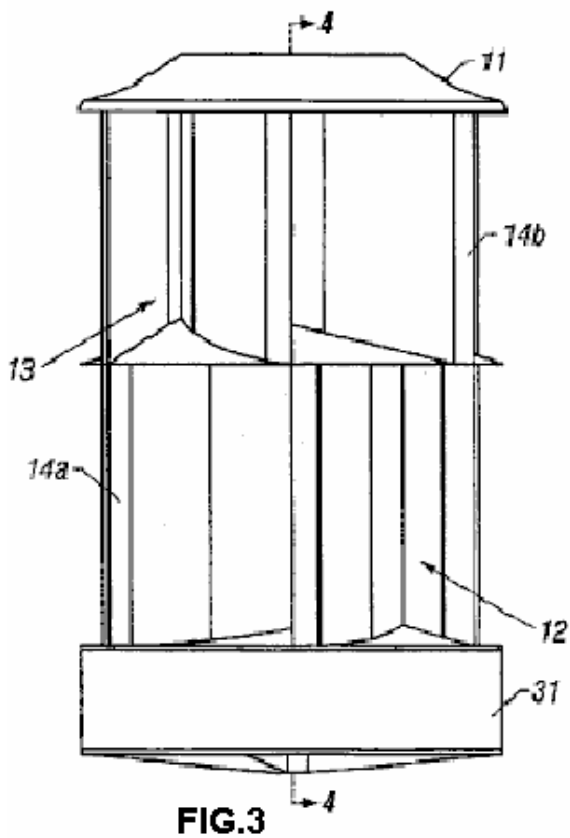

FIG.3

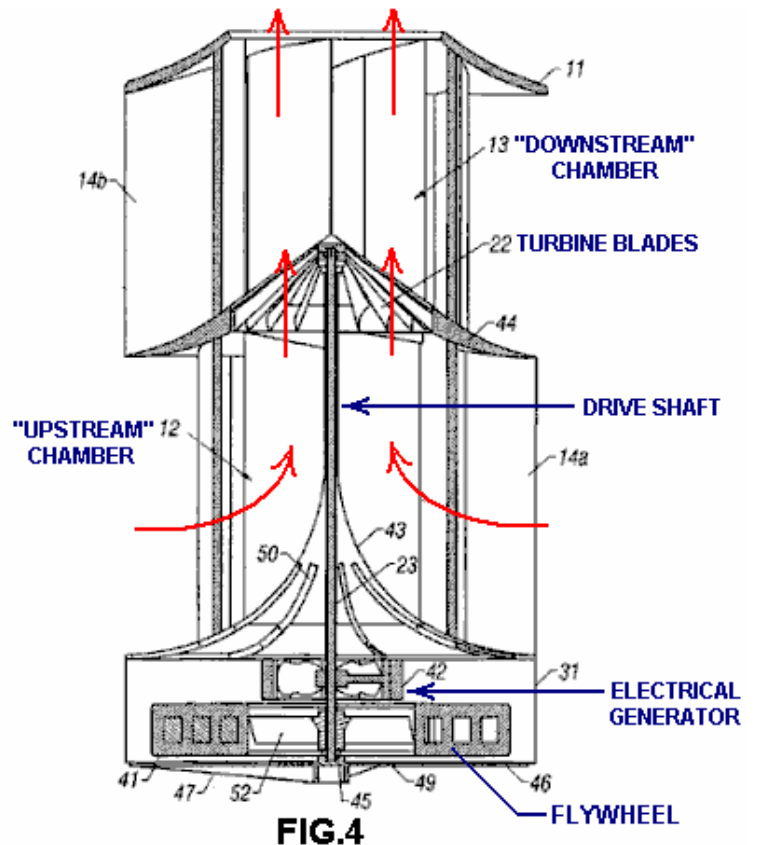

FIG.4

Fig.3 is a side-elevational view of the embodiment of Fig.1 illustrating the profile of the cowling 11, the upstream annular chamber 12, the downstream annular chamber 13, and the baffles 14a and 14b. The cowling may be

mounted on a base **31** and the base **31** may also be used to enclose additional mechanical assemblies such as a flywheel and/or an electrical generator.

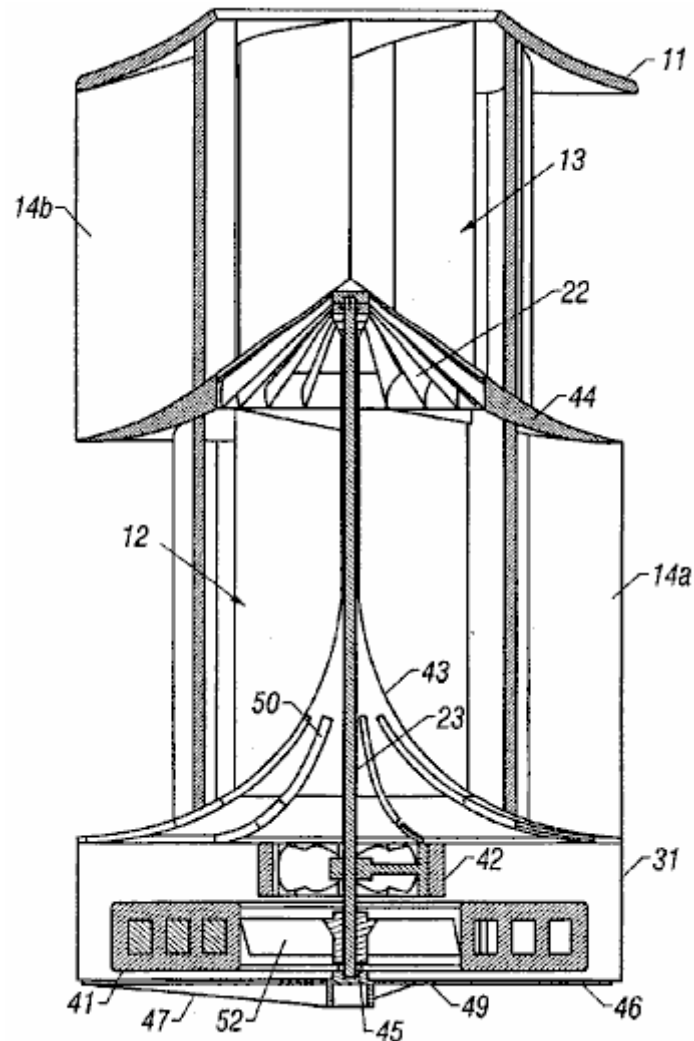

FIG. 4

Fig.4 is a cross-sectional view of the embodiment of **Fig.1** taken along line **4 — 4** of **Fig.3** with a flywheel **41** installed in the base **31** along with an electrical generator **42** to produce electricity. Ambient wind flows simultaneously into the upstream annular chamber **12** through upstream baffles **14a**, and into the downstream annular chamber **13** through the downstream baffles **14b** through the sides of the cowling **11**. The baffles guide the ambient wind towards the centre of the device **10**. A sloping parabolic floor (deck) **43** of the upstream annular chamber **12** causes the wind to flow downstream into the centrally mounted turbine **22** that rotates on the central drive shaft **23**. The device **10** produces power by guiding ambient wind flows into two high-velocity vortices arranged upstream and downstream of the turbine which converts the wind flows to mechanical energy by turning the drive shaft **23**. High-RPM and high-torque are produced by the turbine due to three primary factors:

- (1) each blade of the turbine is shaped like a scoop which captures the rotational momentum of the drive vortex;
- (2) each blade of the turbine has a cross-sectional shape of an airfoil that generates lift in the direction of rotation of the turbine; and
- (3) in low wind conditions, the reversal of the direction of the vortex rotation adds additional force to the turbine in the direction of rotation.

The large flywheel **41** may be attached to the rotating turbine drive shaft **23**. In one embodiment, the flywheel may be a permanent magnet, surrounded by copper windings. The flywheel may serve both as an internal energy storage device due to its angular momentum, and as a dynamo for the generator **42** mounted under the deck **43** of the upstream annular chamber **12**. A solid-state electronic regulator (not shown) may be utilised to control the electrical current load. The regulator maintains a zero load until a preset rotational velocity (RPM) is reached. The load is then increased in order to generate electricity while maintaining the RPM of the turbine at a preselected level.

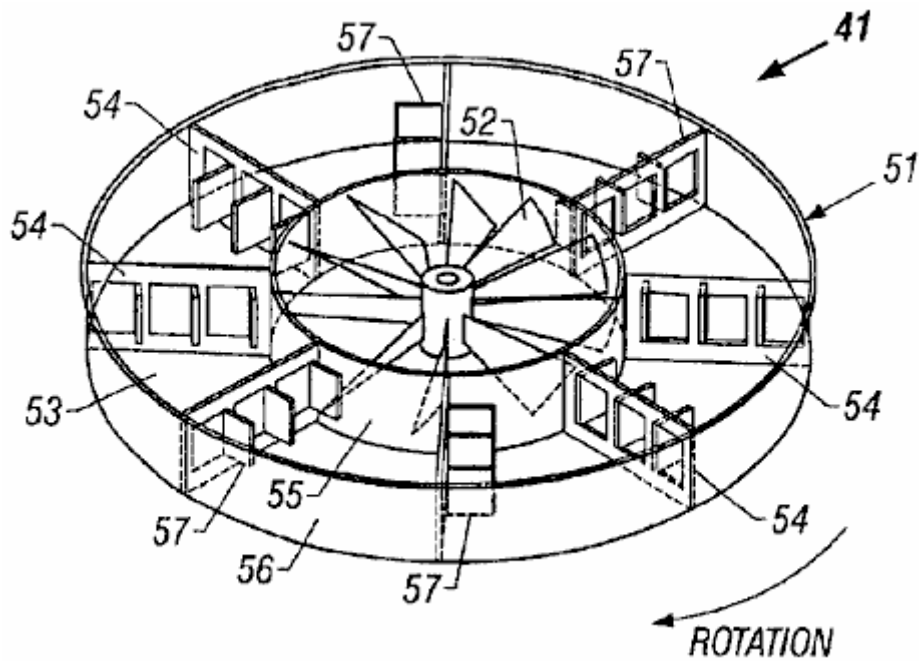

FIG. 5

In **Fig.5** is shown a perspective view of another embodiment of the flywheel **41**. In this embodiment, the flywheel (shown in phantom) includes a hollow disk-shaped shell **51** which is filled with a fluid such as water. The design shown also includes a cooling fan **52** in the hub of the flywheel which rotates with the drive shaft **23** and the flywheel to produce a flow of cooling air that is used to cool the adjacent generator **42** (**Fig.4** and **Fig.7**). The placement of the fan in the hub of the flywheel creates an annular chamber **53** which holds the fluid. Within the chamber, there is a set of radial bulkheads **54** extending from the interior wall **55** to the exterior wall **56** of the chamber. Each of the radial bulkheads includes hinged gates or hatches **57**. In the example version shown here, each radial bulkhead has three hinged gates.

During acceleration of the flywheel **41**, these gates **57** open in the opposite direction of rotation. This allows the fluid to flow through the radial bulkheads **54**, reducing start-up inertia. The fluid then slowly comes up to speed due to friction with the interior and exterior walls **55** and **56** of the annular chamber, and due to the motion of the radial bulkheads through the fluid. During deceleration of the flywheel, the gates close because of the forward momentum of the fluid. This creates solid radial bulkheads and causes the flywheel to perform as a solid flywheel. The angular momentum of the flywheel then helps to maintain the angular velocity of the drive shaft **23** when the input power of the wind drops off.

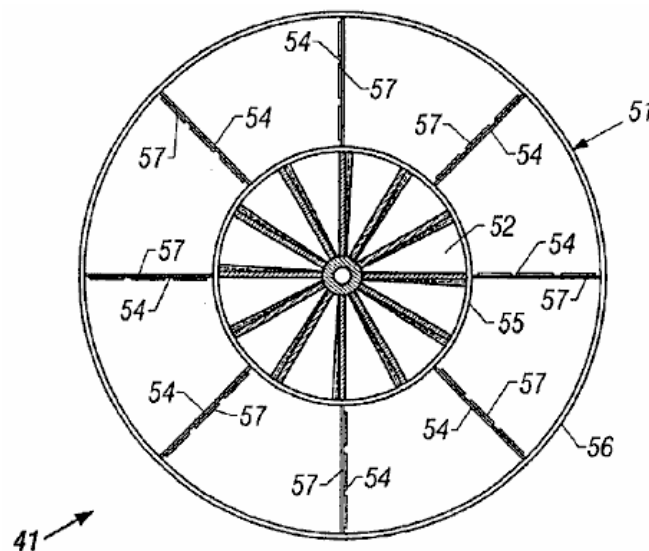

FIG. 6

Fig.6 is a top plan view of the fluid-filled flywheel **41** of **Fig.5** , showing the blades of the cooling fan **52** in the hub of the flywheel, the annular chamber **53**, the radial bulkheads **54**, and the gates **57** in the closed (decelerating) position.

Thus, the fluid-filled flywheel **41** is particularly well suited for use with this energy conversion device **10** of the present invention. The fluid-filled flywheel allows rapid spin-up of the drive shaft **23** by reducing the start-up inertia, but resists deceleration like a solid flywheel. These features can significantly boost the efficiency of a wind-powered or water-powered device that operates with varying input power levels. By simply inverting the flywheel, the fluid-filled flywheel can be used with systems that spin either clockwise or counter-clockwise. As an additional feature, shipping weight is greatly reduced because the fluid can be added at the point of use.

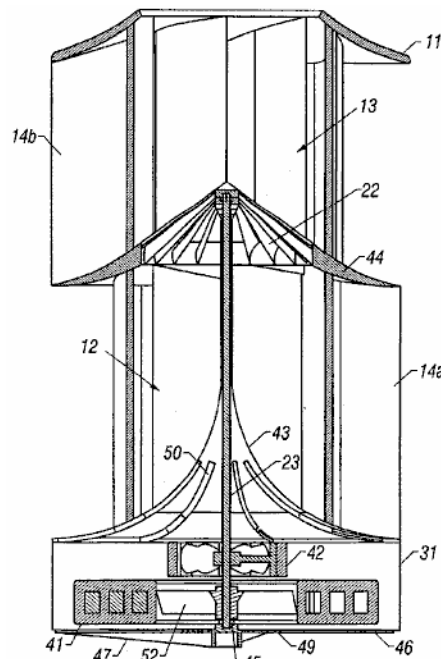

FIG. 4

Referring again to **Fig.4** , an annular central divider (mid-deck) **44** divides the upstream annular chamber **12** from the downstream annular chamber **13**. The top of the mid-deck slopes away from the turbine, causing the ambient wind entering the downstream annular chamber to flow away from the turbine. This creates an area of reduced air pressure on the downstream side of the turbine **22** that increases the flow of air from the upstream annular chamber **12** through the turbine. Each blade of the turbine **22** is a curved airfoil which receives rotational impetus from the rotation of the drive vortex, the reversal of the vortex direction, and aerodynamic lift that is generated by the airfoil in the direction of rotation of the turbine.

In the preferred embodiment of the present invention, the turbine **22** and flywheel **41** may be made of metal. Further, all metal parts may be coated with, for example, plastic, chrome, or paint to prevent corrosion. As discussed above, the flywheel may be a permanent magnet or may be a fluid-filled flywheel. All bearings such as bearing **45** may be magnetic-repulsion-levitation bearings so that there is no physical contact between the moving and stationary elements of the device. The base **31** may be mounted on a support plate **46** and/or a support brace **47**, depending on the structure on which the device is mounted and the orientation of the device.

The central drive shaft **23** may also drive the cooling fan **52** that draws cooling air through vents **49** in the support plate and directs the air through the generator **42**. The heated air may exit through louvers **50** in the parabolic deck **43** of the upstream annular chamber **12** where it then mixes with the driving airflow in the upstream annular chamber to defrost the interior of the device and the turbine **22**.

The device **10** may vary in its dimensions, depending upon the specific application for which it is utilised. For example, the dimensions of a wind-powered device that is mounted on the roof of a house may be between 40 inches and 48 inches in diameter, and between 60 inches and 78 inches in height. In this configuration, the turbine **22** has a diameter approximately one-half the diameter of the exterior of the cowling **11** (i.e. approximately 20 to 24 inches in diameter). Larger versions may be utilised for larger buildings such as factories or office buildings with increased economies of scale. For example, an office building may use a device that is 20 feet in diameter and 20 feet tall with a turbine that is 10 feet in diameter. A vehicle-mounted device (for example, for a passenger car), designed for high-wind conditions, may be about 24 inches in diameter and 6 inches in height. The generator and flywheel, if any, may be mounted inside the contour of the vehicle, or on a luggage rack. A

small hydro-electric version of the device that is placed in a running stream or river may have similar dimensions to the vehicle-mounted device. In addition, since the outflow of the hydro-electric version is directed downward, a deflector may be utilised in shallow bodies of water to prevent erosion of the stream bed.

It should be noted that when the present invention is oriented vertically, the turbine **22**, the generator **42**, and the flywheel **41** rotate around a vertical axis. Therefore, the supporting structures are not subject to the vibration and stress produced by gravity effects in prior art devices in which propellers rotate around a horizontal axis. Moreover, exceptional wind-conversion efficiency is realized from the present invention as it diverts and accelerates the ambient wind flow into vortices that have several times the velocity of the ambient wind flow when they reach the turbine. Additionally, the acceleration of the air flow into the upstream and downstream annular chambers creates a low pressure area that pulls air into the device from an effective cross-sectional area that is greater than the physical cross-sectional area of the device. As a result, the present invention provides a new and improved wind-power conversion device which is quieter, safer, more efficient, and more cost effective than existing devices.

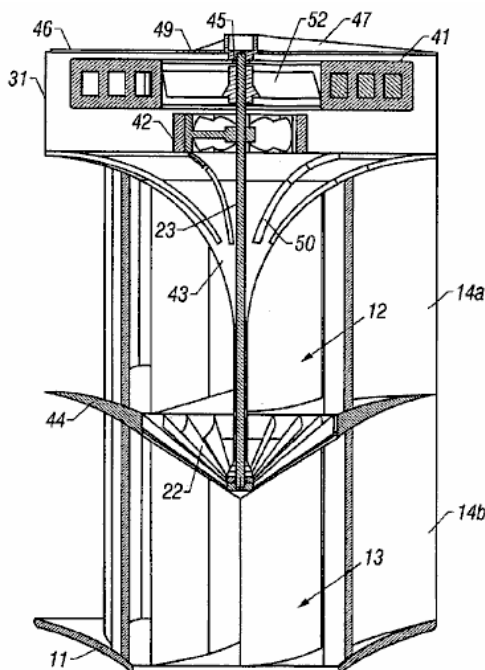

FIG. 7

Referring now to **Fig.7**, there is shown a cross-sectional view of a version of the present invention which converts the energy of flowing water to electrical energy (i.e. a hydro-electrical device). There are three key differences between the hydro-electrical embodiment from the low-wind-powered embodiment of **Figs. 1 to 4**. Firstly, the upstream baffles **14a** and the downstream baffles **14b** curve in the same direction. The baffles therefore create two high-velocity vortices which rotate in the same direction. This is a more efficient design when the fluid flowing through the device is an incompressible fluid such as water. Secondly, the device operates more efficiently when it is inverted and mounted vertically since water vortices move downward due to the force of gravity. The third difference is the ratio of the height of the device to the diameter of the device. As noted above, the hydro-electric embodiment of the device may have a height that is shorter when compared to its diameter, and may have a height that is equal to or less than its diameter.

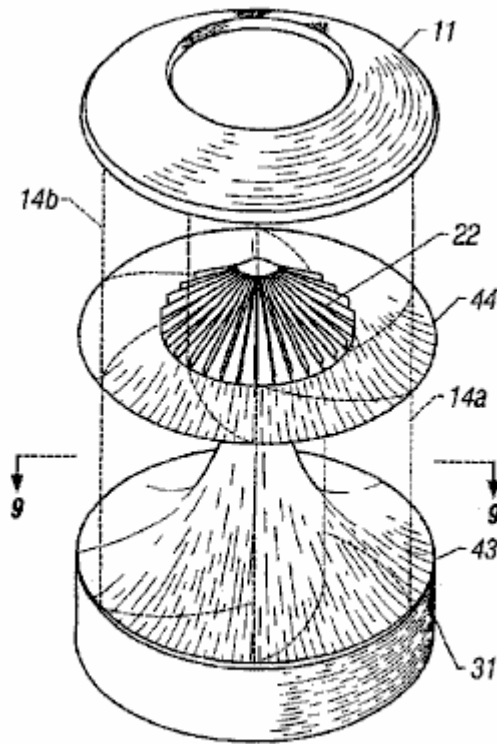

FIG. 8

Fig.8 is a perspective view of the embodiment of **Fig.1** with the toroidal longitudinal baffles **14a** and **14b** drawn in phantom so that the annular central divider (mid-deck) **44** and turbine **22** can be seen.

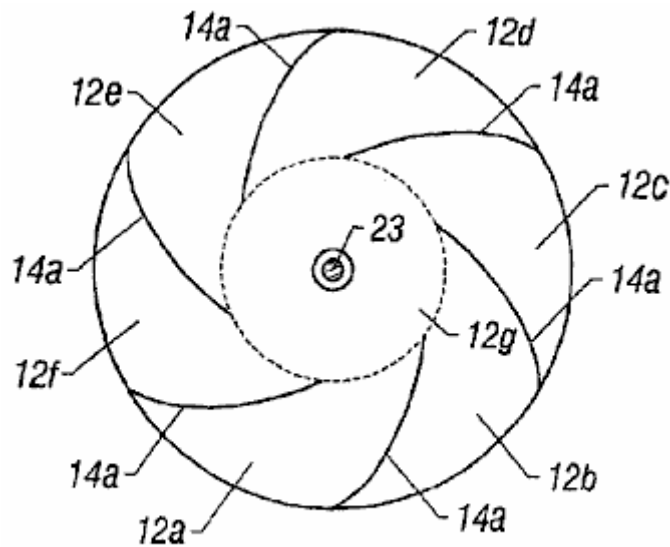

FIG. 9

Fig.9 is a horizontal cross-sectional view of the embodiment of **Fig.1** taken along line **9 — 9** of **Fig.8**. In this view, it can be seen that the upstream annular chamber **12** is divided into a set of smaller chambers **12a** through **12f** by the toroidal longitudinal baffles **14a**. The interior ends of the longitudinal baffles define a central vortex chamber **12g** (illustrated by a dashed circle) in which the upstream vortex is formed, and from which the upstream vortex enters the turbine **22**. The central vortex chamber **12g** has a diameter approximately equal to the diameter of the turbine.

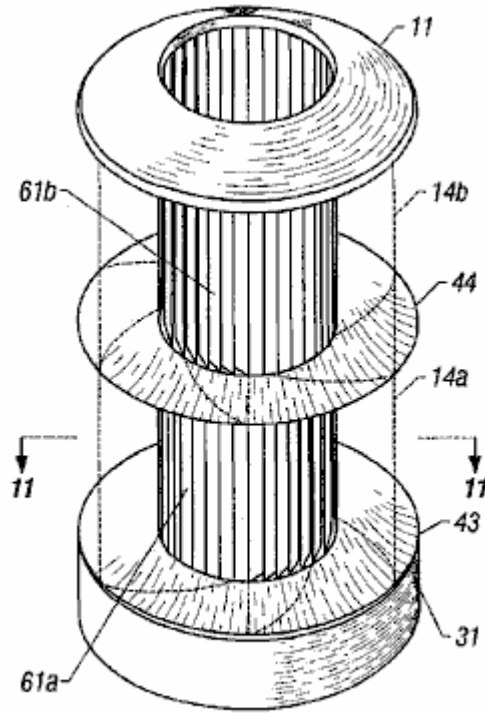

FIG. 10

Fig.10 is a perspective view of a second embodiment of the present invention that converts wind energy to mechanical or electrical energy, with the longitudinal baffles **14a** and **14b** drawn in phantom so that a set of hinged longitudinal louvers **61a** and **61b** can be seen. The hinged louvers are mounted in the openings between the longitudinal baffles. The louvers may be mounted in a circular configuration anywhere from the outside edge of the longitudinal baffles to the inside edge of the baffles. In the version shown, the louvers are longitudinally mounted at the inside edge of the baffles, around the perimeter of the central vortex chamber **12g**. Each of the louvers is hinged on one side (i.e., the windward side as wind enters through the baffles) so that the louver may be opened toward the central vortex chamber by the force of the incoming wind. The width of each louver is slightly greater than the distance between louvers so that each louver slightly overlaps the hinged edge of the next louver. This prevents the louvers from opening outward.

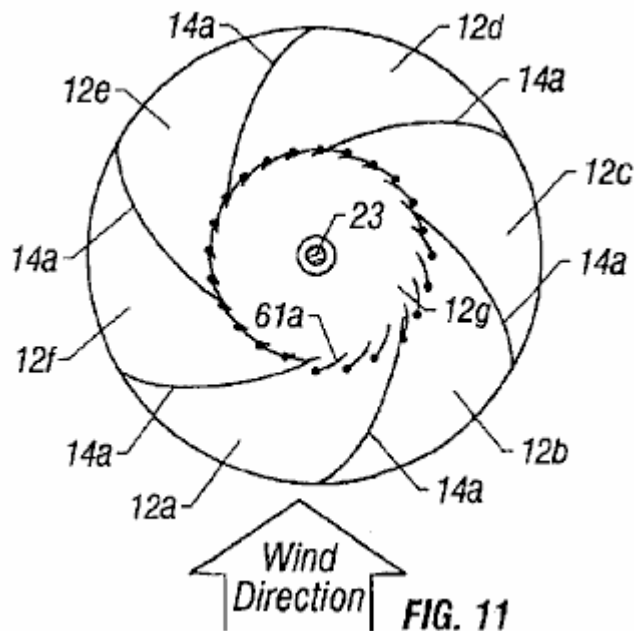

FIG. 11

In **Fig.11** there is shown a horizontal cross-sectional view of the embodiment of **Fig.10** taken along line **11 — 11**. During operation, wind blowing in the direction shown from the outside of the energy conversion device is funneled by the toroidal longitudinal baffles **14a** into upstream chambers **12a** and **12b**. The baffles block the wind from entering the other chambers **12c** through **12f**. The wind flows through chambers **12a** and **12b**, and enters

the central vortex chamber **12g** by opening the hinged longitudinal louvers **61a** which are mounted between the baffles in the openings defining chambers **12a** and **12b**. The remaining louvers remain closed, preventing the wind from exiting through the sides of the device. Thus, the wind-activated louvers are, in effect, one-way valves allowing the wind to flow into the central vortex chamber through the sides of the device, but only allowing the wind to exit through the top of the chamber, and through the turbine **22**.

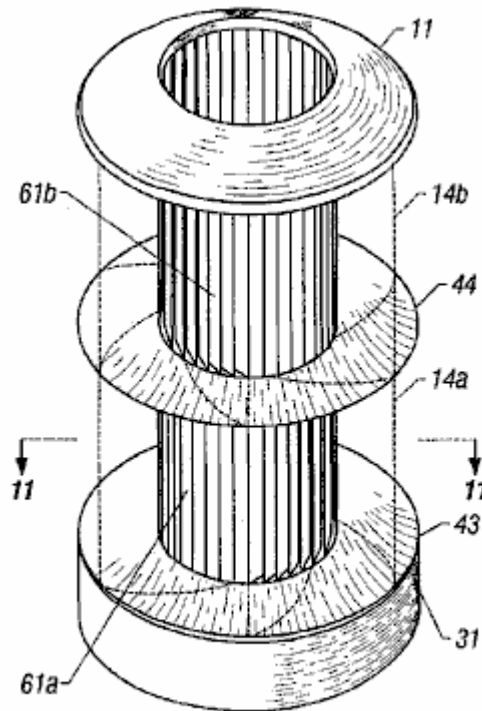

FIG. 10

Referring again to **Fig.10**, it can be seen that the longitudinal louvers **61a** mounted in the upstream chamber **12** are hinged on the opposite side from the louvers **61b** mounted in the downstream chamber **13**. This is because the vortex in the downstream chamber rotates in the opposite direction from the vortex in the upstream chamber, and the downstream toroidal baffles **14b** funnel the wind into the louvers **61b** in the opposite direction. Like the louvers **61a** in the upstream chamber **12**, the louvers **61b** in the downstream chamber **13** act as one-way valves allowing the wind to flow into the central vortex chamber through the sides of the device, but only allowing the wind to exit through the top of the chamber, and out of the device. This configuration helps to maintain the strength of both the upstream and the downstream vortices during operation of the device.

It should be recognized that some degree of improved energy-conversion performance may be obtained in a configuration in which there are toroidal baffles **14a** and hinged louvers **61a** only in the upstream annular chamber **12** because this ensures that all of the wind or other fluid entering the sides of the upstream chamber flows through the turbine. The addition of toroidal baffles **14b** in the downstream annular chamber **13** provides additional improved performance, particularly when the direction of rotation of the downstream vortex is opposite the direction of the upstream vortex. Optimum energy-conversion performance is provided by a device having oppositely configured toroidal baffles **14a** and **14b**, and oppositely hinged louvers **61a** and **61b**, for both the upstream annular chamber **12** and the downstream annular chamber **13**.

It is to be understood that even though numerous characteristics and advantages of the present invention have been set forth in the foregoing description, the disclosure is illustrative only, and changes may be made in detail, especially in matters of size, shape, and arrangement of parts within the principles of the invention to the full extent indicated by the broad general meaning of the terms in which the appended claims are expressed.

Claims:

What is claimed is:

1. A fluid-powered energy conversion device for converting energy in a moving fluid into mechanical energy, said device comprising: a rigid cylindrical frame having an upstream annular chamber and a downstream annular chamber, each of said chambers having sides that are open to allow entry of the moving fluid; a first set of baffles

longitudinally mounted in the upstream chamber that operate to create in the upstream chamber, an upstream drive vortex rotating in a first direction when the moving fluid enters the upstream chamber through the upstream chamber's open sides and through openings between the baffles; a first set of hinged louvers positioned in the openings between the first set of baffles and encircling an upstream central vortex chamber centered around a central longitudinal axis of the device, said first set of louvers being operable to permit entry of the moving fluid into the upstream central vortex chamber only when the fluid is rotating in the first direction, and to prevent the fluid from exiting the upstream central vortex chamber through the sides of the device; a floor of the upstream annular chamber that slopes toward the downstream chamber as the floor approaches the central longitudinal axis of the device, said floor causing the drive vortex to flow downstream through the upstream central vortex chamber and pass through a central aperture located between the upstream annular chamber and the downstream annular chamber; a longitudinal drive shaft centrally mounted in the central aperture; and a turbine mounted on the drive shaft in the central aperture, said turbine being rotated by the drive vortex as the drive vortex passes through the central aperture.

2. The fluid-powered energy conversion device of claim 1 further comprising a second set of baffles longitudinally mounted in the downstream chamber that operate to create in the downstream chamber, a downstream extraction vortex rotating in a direction opposite to the first direction when the moving fluid enters the downstream chamber through the downstream chamber's open sides and through openings between the baffles, whereby the turbine is rotated by the drive vortex as the drive vortex passes through the turbine and reverses direction to match the direction of the extraction vortex.

3. The fluid-powered energy conversion device of claim 2 further comprising an annular central divider between the upstream chamber and the downstream chamber, said divider having a downstream surface that slopes downstream as it approaches the central longitudinal axis of the device, said downstream surface causing the extraction vortex to flow downstream, thereby creating an area of reduced fluid pressure downstream of the turbine.

4. The fluid-powered energy conversion device of claim 2 further comprising a second set of hinged louvers positioned in the openings between the second set of baffles and encircling a downstream central vortex chamber centered around the central longitudinal axis of the device, said second set of louvers being operable to permit entry of the moving fluid into the downstream central vortex chamber only when the fluid is rotating in the direction opposite to the first direction, and to prevent the fluid from exiting the downstream central vortex chamber through the sides of the device.

5. The fluid-powered energy conversion device of claim 4 wherein said first set of baffles are curved to form a toroidal pattern in the first direction, and said second set of baffles are curved to form a toroidal pattern in the direction opposite to the first direction.

6. The fluid-powered energy conversion device of claim 5 wherein said turbine comprises a set of rotating blades, each of said blades having a cross-sectional shape of a curved airfoil that generates a lift force, said lift force being directed in the direction of rotation of the turbine.

7. The fluid-powered energy conversion device of claim 1 further comprising a flywheel mounted on the drive shaft, said flywheel having sufficient mass to operate as an internal energy storage device due to its angular momentum.

8. The fluid-powered energy conversion device of claim 7 wherein said flywheel is a permanent magnet.

9. The fluid-powered energy conversion device of claim 7 wherein said flywheel is a fluid-filled flywheel that rotates with the drive shaft in a direction of rotation, said fluid-filled flywheel comprising: a hollow disk-shaped shell filled with fluid; and a set of radial bulkheads that separate the interior of the shell into separate sections, each of said bulkheads having at least one gate pivotally mounted thereon to open in a direction opposite to the direction of rotation, said gate covering an aperture in the bulkhead when the gate is pivoted to a closed position, and said gate opening the aperture when the gate is pivoted to an open position; whereby the gates are opened by the fluid when the flywheel accelerates in the direction of rotation, thus allowing the fluid to flow through the apertures in the bulkheads and reduce start-up inertia of the flywheel, and whereby the gates are closed by the fluid when the flywheel decelerates, thus preventing the fluid from flowing through the apertures, and causing the flywheel to maintain angular momentum like a solid flywheel.

10. The fluid-powered energy conversion device of claim 9 wherein the hollow disk-shaped shell includes: an annular compartment filled with the fluid; and a cooling fan mounted in a central hub section of the shell.

11. The fluid-powered energy conversion device of claim 1 further comprising an electrical generator mounted on the drive shaft, said generator converting mechanical energy from the rotation of the shaft into electrical energy.

12. The fluid-powered energy conversion device of claim 11 further comprising a cooling fan mounted on the drive shaft, said cooling fan directing cooling air through the generator.

13. A wind-powered energy conversion device for converting wind energy into mechanical energy, said device comprising: a rigid cylindrical frame having an upstream annular chamber, a downstream annular chamber, and an annular central divider between the upstream chamber and the downstream chamber, each of said chambers having sides that are open to allow entry of ambient wind, and said annular central divider having a central aperture therein and having a downstream surface that slopes downstream as it approaches a central longitudinal axis of the device; a first set of baffles longitudinally mounted in the upstream chamber and curved to form a toroidal pattern that operates to create in an upstream central vortex chamber cantered around a central longitudinal axis of the device, an upstream drive vortex rotating in a first direction when the ambient wind enters the upstream chamber through the upstream chamber's open sides and through openings between the baffles; a first set of hinged louvers positioned in the openings between the first set of baffles and encircling the upstream central vortex chamber, said first set of louvers being operable to permit entry of the wind into the upstream central vortex chamber only when the wind is rotating in the first direction, and to prevent the wind from exiting the upstream central vortex chamber through the sides of the device; a second set of baffles longitudinally mounted in the downstream chamber and curved to form a toroidal pattern operable to create in a downstream central vortex chamber cantered around the central longitudinal axis of the device, a downstream extraction vortex rotating in a direction opposite to the first direction when the ambient wind enters the downstream chamber through the downstream chamber's open sides and through openings between the baffles; a second set of hinged louvers positioned in the openings between the second set of baffles and encircling the downstream central vortex chamber, said second set of louvers being operable to permit entry of the wind into the downstream central vortex chamber only when the wind is rotating in the direction opposite to the first direction, and to prevent the wind from exiting the downstream central vortex chamber through the sides of the device; a floor of the upstream annular chamber that slopes downstream as the floor approaches a central longitudinal axis of the device, said floor causing the drive vortex to flow downstream and pass through the central aperture in the annular central divider; a longitudinal drive shaft centrally mounted in the central aperture; and a turbine mounted on the drive shaft in the central aperture, said turbine comprising a set of rotating blades, each of said blades having a cross-sectional shape of a curved airfoil that generates a lift force, said lift force being directed in the direction of rotation of the turbine, said turbine being rotated by the drive vortex as the drive vortex passes through the turbine and reverses direction to match the direction of the extraction vortex.

14. The wind-powered energy conversion device of claim 13 further comprising a flywheel mounted on the drive shaft, said flywheel having sufficient mass to operate as an internal energy storage device due to its angular momentum.

15. The wind-powered energy conversion device of claim 13 further comprising an electrical generator mounted on the drive shaft, said generator converting mechanical energy from the rotation of the shaft into electrical energy.

16. The wind-powered energy conversion device of claim 13 wherein the extraction vortex rotates in a counter-cyclonic direction so that the extraction vortex dissipates after it exits the downstream chamber.

17. A wind-powered energy conversion device for converting high-speed wind energy into mechanical energy, said device comprising: a rigid cylindrical frame having an upstream annular chamber and a downstream annular chamber, each of said chambers having sides that are open to allow entry of the high-speed wind; a first set of baffles longitudinally mounted in the upstream chamber that create in an upstream central vortex chamber, an upstream drive vortex rotating in a first direction when the high-speed wind enters the upstream chamber through the upstream chamber's open sides and through openings between the baffles; a first set of hinged louvers positioned in the openings between the first set of baffles and encircling the upstream central vortex chamber, said first set of louvers being operable to permit entry of the wind into the upstream central vortex chamber only when the wind is rotating in the first direction, and to prevent the wind from exiting the upstream central vortex chamber through the sides of the device; a second set of baffles longitudinally mounted in the downstream chamber that create in a downstream central vortex chamber, a downstream extraction vortex rotating in the first direction when the high-speed wind enters the downstream chamber through the downstream chamber's open sides and through openings between the baffles; a second set of hinged louvers positioned in the openings between the second set of baffles and encircling the downstream central vortex chamber, said second set of louvers being operable to permit entry of the wind into the downstream central vortex chamber only when the wind is rotating in the first direction, and to prevent the wind from exiting the downstream central vortex chamber through the sides of the device; a floor of the upstream annular chamber that slopes downstream as the floor approaches a central longitudinal axis of the device, said floor causing the drive vortex to flow downstream and pass through a central aperture located between the upstream annular chamber and the downstream annular chamber; a longitudinal drive shaft centrally mounted in the central aperture; and a turbine mounted on the drive

shaft in the central aperture, said turbine being rotated by the drive vortex as the drive vortex passes through the turbine.

18. The wind-powered energy conversion device of claim 17 further comprising a fluid-filled flywheel mounted on the drive shaft that rotates with the drive shaft in a direction of rotation, said fluid-filled flywheel comprising: a hollow disk-shaped shell filled with fluid; and a set of radial bulkheads that separate the interior of the shell into separate sections, each of said bulkheads having at least one gate pivotally mounted thereon to open in a direction opposite to the direction of rotation, said gate covering an aperture in the bulkhead when the gate is pivoted to a closed position, and said gate opening the aperture when the gate is pivoted to an open position; whereby the gates are opened by the fluid when the flywheel accelerates in the direction of rotation, thus allowing the fluid to flow through the apertures in the bulkheads and reduce start-up inertia of the flywheel, and whereby the gates are closed by the fluid when the flywheel decelerates, thus preventing the fluid from flowing through the apertures, and causing the flywheel to maintain angular momentum like a solid flywheel.

19. A water-powered energy conversion device for converting energy in a moving stream of water into mechanical energy, said device comprising: a rigid cylindrical frame having an upstream annular chamber and a downstream annular chamber, each of said chambers having sides that are open to allow entry of the stream of water; a first set of baffles longitudinally mounted in the upstream chamber that create in an upstream central vortex chamber, an upstream drive vortex rotating in a first direction when the stream of water enters the upstream chamber through the upstream chamber's open sides and through openings between the baffles; a first set of hinged louvers positioned in the openings between the first set of baffles and encircling the upstream central vortex chamber, said first set of louvers being operable to permit entry of the water into the upstream central vortex chamber only when the water is rotating in the first direction, and to prevent the water from exiting the upstream central vortex chamber through the sides of the device; a second set of baffles longitudinally mounted in the downstream chamber that create in a downstream central vortex chamber, a downstream extraction vortex rotating in the first direction when the stream of water enters the downstream chamber through the downstream chamber's open sides and through openings between the baffles; a second set of hinged louvers positioned in the openings between the second set of baffles and encircling the downstream central vortex chamber, said second set of louvers being operable to permit entry of the water into the downstream central vortex chamber only when the water is rotating in the first direction, and to prevent the water from exiting the downstream central vortex chamber through the sides of the device; a floor of the upstream annular chamber that slopes downstream as the floor approaches a central longitudinal axis of the device, said floor causing the drive vortex to flow downstream and pass through a central aperture located between the upstream annular chamber and the downstream annular chamber; a longitudinal drive shaft centrally mounted in the central aperture; and a turbine mounted on the drive shaft in the central aperture, said turbine being rotated by the drive vortex as the drive vortex passes through the turbine.

20. The water-powered energy conversion device of claim 19 further comprising a fluid-filled flywheel mounted on the drive shaft that rotates with the drive shaft in a direction of rotation, said fluid-filled flywheel comprising: a hollow disk-shaped shell filled with fluid; and a set of radial bulkheads that separate the interior of the shell into separate sections, each of said bulkheads having at least one gate pivotally mounted thereon to open in a direction opposite to the direction of rotation, said gate covering an aperture in the bulkhead when the gate is pivoted to a closed position, and said gate opening the aperture when the gate is pivoted to an open position; whereby the gates are opened by the fluid when the flywheel accelerates in the direction of rotation, thus allowing the fluid to flow through the apertures in the bulkheads and reduce start-up inertia of the flywheel, and whereby the gates are closed by the fluid when the flywheel decelerates, thus preventing the fluid from flowing through the apertures, and causing the flywheel to maintain angular momentum like a solid flywheel.

21. A fluid-powered energy conversion device for converting energy in a moving fluid into mechanical energy, said device comprising: a rigid cylindrical frame having an upstream annular chamber and a downstream annular chamber cantered around a longitudinal axis, each of said chambers having sides that are open to allow entry of the moving fluid in a direction approximately perpendicular to the longitudinal axis, said upstream and downstream chambers being separated by an annular divider having a central aperture therein; a longitudinal drive shaft centrally mounted along the longitudinal axis and passing through the central aperture; a turbine mounted on the drive shaft in the central aperture; means for creating in the upstream chamber an upstream drive vortex rotating in a first direction when the moving fluid enters the upstream chamber through the upstream chamber's open sides; means for creating in the downstream chamber, a downstream extraction vortex rotating in a second direction opposite to the first direction when the moving fluid enters the downstream chamber through the downstream chamber's open sides; end means for causing the drive vortex to flow downstream and pass through the turbine, said turbine being rotated by the drive vortex as the drive vortex passes through the turbine and reverses direction to match the direction of the extraction vortex.

22. The fluid-powered energy conversion device of claim 21 wherein the means for creating an upstream drive vortex in the upstream chamber includes a first set of longitudinally mounted baffles having openings between

them through which the moving fluid enters the upstream chamber, said first set of baffles being curved to form a toroidal pattern in the first direction.

23. The fluid-powered energy conversion device of claim 22 wherein the means for creating an upstream drive vortex in the upstream chamber includes a first set of hinged louvers positioned in the openings between the first set of baffles and encircling the upstream chamber, said first set of louvers being operable to permit entry of the moving fluid into the upstream chamber only when the fluid is rotating in the first direction, and to prevent the fluid from exiting the upstream chamber through the sides of the device.

24. The fluid-powered energy conversion device of claim 23 wherein the means for creating a downstream extraction vortex in the downstream chamber includes a second set of longitudinally mounted baffles having openings between them through which the moving fluid enters the upstream chamber, said second set of baffles being curved to form a toroidal pattern in the second direction.

25. The fluid-powered energy conversion device of claim 24 wherein the means for creating a downstream extraction vortex in the downstream chamber includes a second set of hinged louvers positioned in the openings between the second set of baffles and encircling the downstream chamber, said second set of louvers being operable to permit entry of the moving fluid into the downstream chamber only when the fluid is rotating in the second direction, and to prevent the fluid from exiting the downstream chamber through the sides of the device.

26. The fluid-powered energy conversion device of claim 25 wherein the means for causing the drive vortex to flow downstream includes means for creating a pressure differential in which the fluid pressure in the downstream chamber is less than the fluid pressure in the upstream chamber.

27. The fluid-powered energy conversion device of claim 26 wherein the means for creating a pressure differential includes a downstream surface of the annular divider that slopes downstream as it approaches the central longitudinal axis of the device, said downstream surface causing the extraction vortex to flow downstream, thereby creating an area of reduced fluid pressure downstream of the turbine.

28. The fluid-powered energy conversion device of claim 27 wherein the means for causing the drive vortex to flow downstream includes a floor of the upstream annular chamber that slopes toward the downstream chamber as the floor approaches the central longitudinal axis of the device, said floor causing the drive vortex to flow downstream and pass through the turbine.

29. The fluid-powered energy conversion device of claim 21 further comprising a fluid-filled flywheel that rotates with the drive shaft in a direction of rotation, said fluid-filled flywheel comprising: a hollow disk-shaped shell filled with fluid; and a set of radial bulkheads that separate the interior of the shell into separate sections, each of said bulkheads having at least one gate pivotally mounted thereon to open in a direction opposite to the direction of rotation, said gate covering an aperture in the bulkhead when the gate is pivoted to a closed position, and said gate opening the aperture when the gate is pivoted to an open position; whereby the gates are opened by the fluid when the flywheel accelerates in the direction of rotation, thus allowing the fluid to flow through the apertures in the bulkheads and reduce start-up inertia of the flywheel, and whereby the gates are closed by the fluid when the flywheel decelerates, thus preventing the fluid from flowing through the apertures, and causing the flywheel to maintain angular momentum like a solid flywheel.

ELECTRIC ENERGY GENERATION SYSTEM WITH FEEDBACK

Note: These three patents are in Portuguese and what is shown here is a low-quality attempt at translation into English using a translation program. The originals can be downloaded free from: http://worldwide.espacenet.com/singleLineSearch?locale=en_EP.

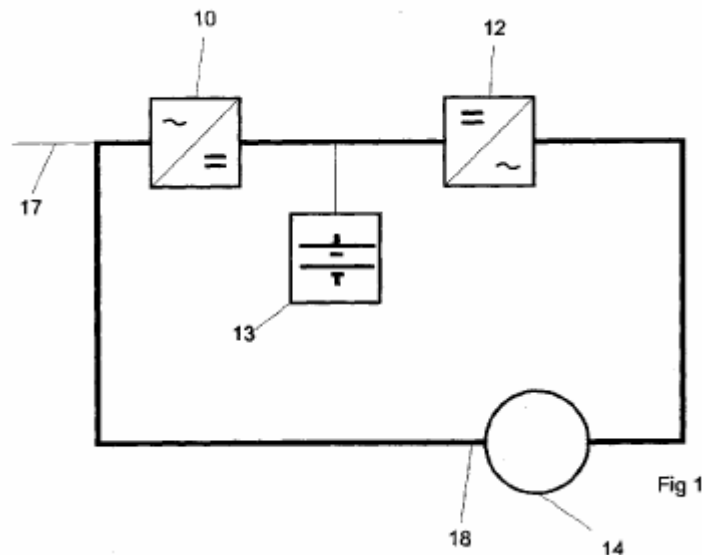

Abstract:

The present invention relates to electric energy generation equipment comprising a basic circuit formed by a rectifier (10), for example, an AC/DC converter connected in series to an inverter (12), for example, a DC/AC converter, and a bank of batteries (13) connected in series between the rectifier (10) and the inverter (12). An electron-capturing element (14), which can be either a free space electron-capturing element or, alternatively, an earth electron-capturing element, is connected in series to the basic circuit formed by the rectifier (10), the inverter (12) and the battery assembly (13). The bank of batteries (13) powers the basic circuit because it is connected to the system. Consequently, the inverter (12) converts direct current into alternating current and supplies this current to the electron-capturing element (14). After receiving the electric current from the inverter (12), the electron-capturing element (14) starts capturing electrons from the alternating current and powering the rectifier (10), which converts the alternating current into a direct current in order to recharge the bank of batteries (13) and power the inverter (12) which powers the electron-capturing element, closing the feedback loop, and also providing electric energy for consumption by external loads.

WIPO Patent Application WO/2013/104043 Filing Date: 01/11/2013

Application Number: BR2013/000016 Publication Date: 07/18/2013

Assignee: EVOLUÇÕES ENERGIA LTDA (Rua Santa Tereza 1427-B Centro - Imperatriz -MA, CEP -470 - Maranhão, 65900, BR)

SELF-POWERED ELECTRICITY GENERATOR.

Technical field

The present invention relates to a device for generating electricity, in particular self-powered equipment for generating electricity.

Description of the Related Art

There are many methods for generating electricity using electromagnetism, but all of these are electromechanical devices using magnets and have limited generating capacity and an ecological impact which makes them unsuited to large scale projects.

Objectives of the Invention

The aim of this invention is the sustainable generation of electricity, using a generator which is able to produce large amounts of electricity from an extremely low input current, which initially is supplied by a bank of batteries, but subsequently is supplied by the output from the generator which is also able to power external loads.

The above objective, and other objectives, are achieved by the present invention through the use of a typical Uninterruptible Power Supply circuit comprising of an AC/DC rectifier feeding a battery bank which powers a DC/AC inverter, which is connected to a device to trap electrons from space (as described in Brazilian patent application No. BR1020120008378 of 13th January 2012) or alternatively, a device which extracts electrons from the Earth (as described in Brazilian patent application No. BR1020120008386 of 13th January 2012), which then passes the extracted electrons to the AC/DC rectifier, charging the battery bank, thus closing the loop as well as providing electricity to power external loads.

The self-powered system for generating electricity from the present invention can be fixed or mobile. It is fixed when using electron capture from the earth due to the ground connection, or mobile when using electron capture from space.

The self-powered electricity generating system of this invention may be configured in several different ways, each using the same inventive concept but using different arrangements of components. Different versions include single-phase, two-phase or three-phase versions, producing outputs of any power and voltage.

Brief Description of the Drawings

The present invention will now be described with the aid of drawings, but this patent is not limited to the versions and details shown in these drawings, although they show additional details and advantages of the present invention.

The drawings:

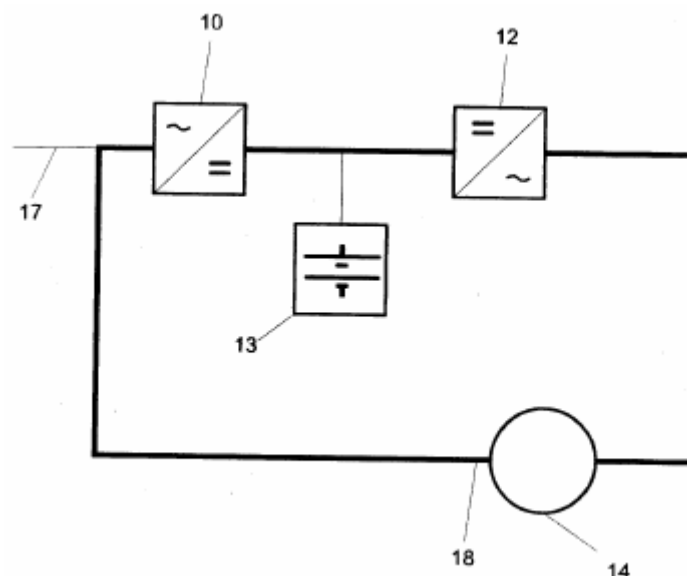

Figure 1 - shows a basic circuit system for self-powered electricity generation of the present invention

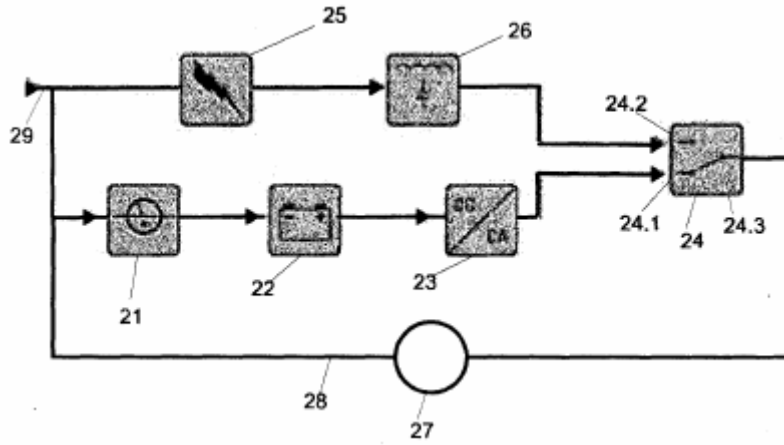

Figure 2 - shows a first embodiment of the constructive system for self-powered electricity generation of the present invention;

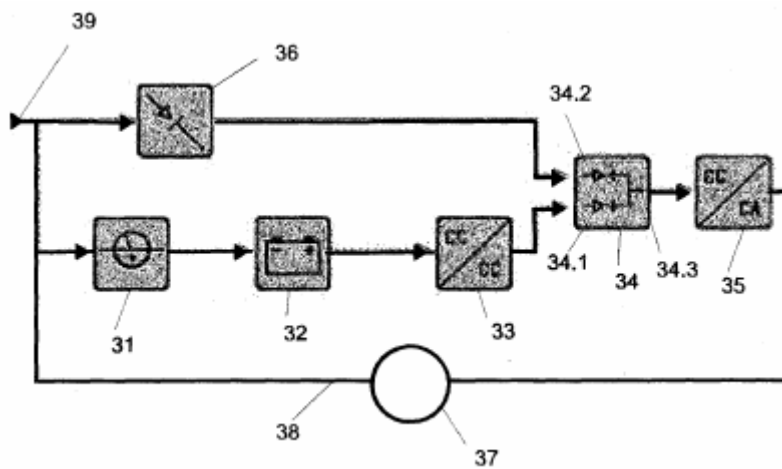

Figure 3 - shows a second embodiment of the self-powered system for generating electricity of the present invention;

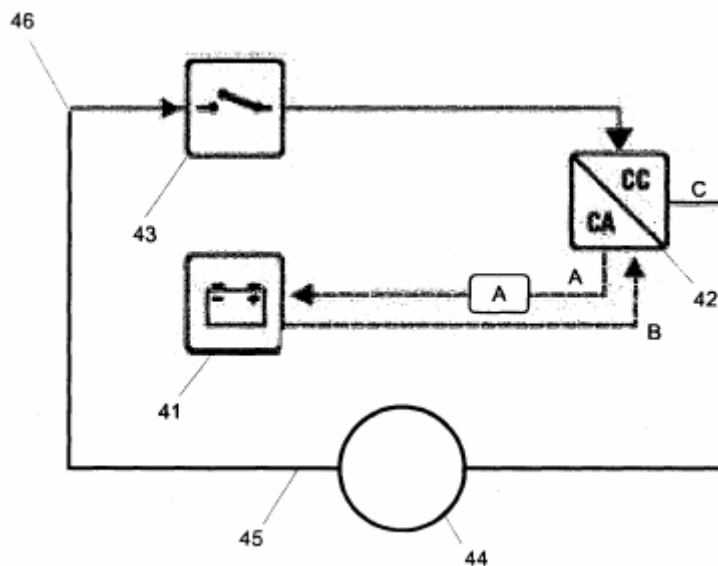

Figure 4 - shows a third embodiment of the self-powered system for generating electricity of the present invention;

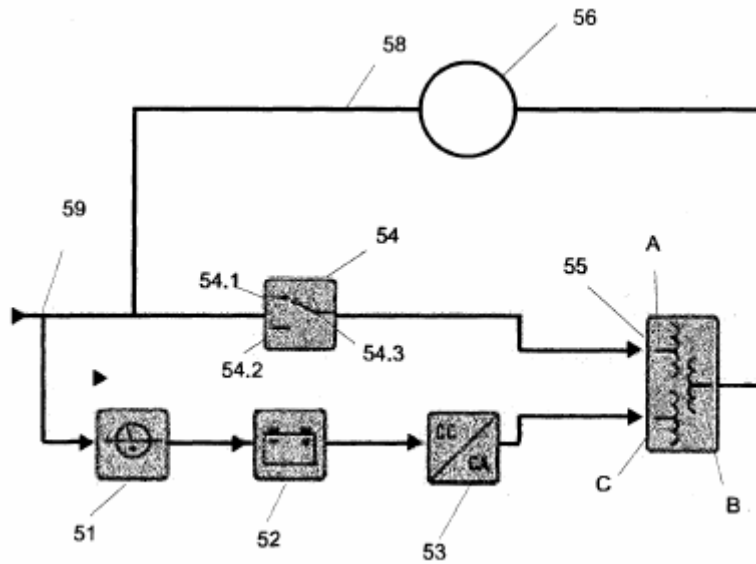

Figure 5 - shows a fourth embodiment of the self-powered system for generating electricity of the present invention;

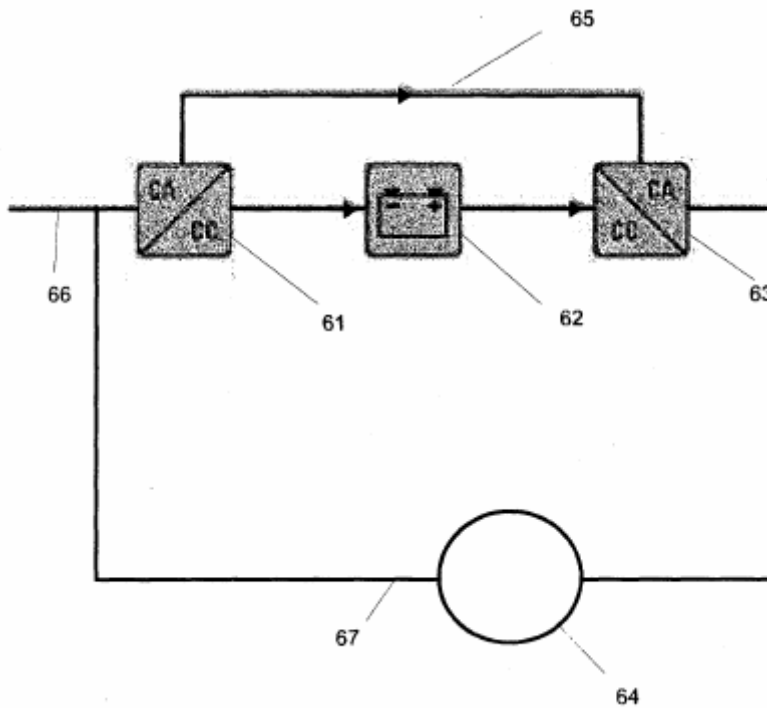

Figure 6 - shows a fifth embodiment of the self-powered system for generating electricity of the present invention;

Detailed description of the Invention:

There are different ways of closing the self-feeding cycle depending on the circuit configuration chosen. Some of these arrangements are shown in **Figures 2 to 6**, wherein the main circuitry continues to oscillate, continuously generating instant electricity.

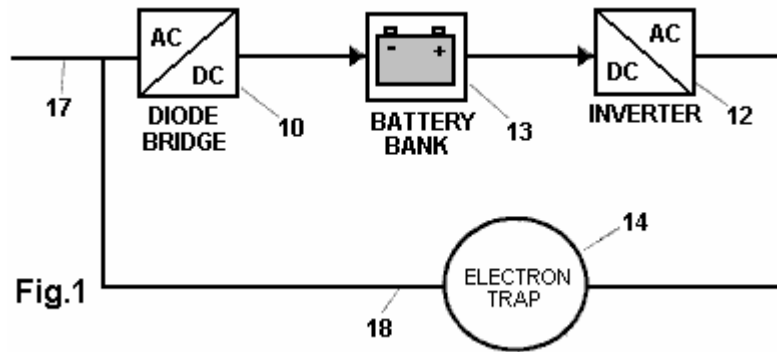

Fig.1

As shown in **Fig.1**, the self-powered system for generating electricity comprises a basic circuit consisting of a rectifier (AC/DC converter) **10** which is connected in series to an inverter (DC/AC) **12**. A bank of batteries **13** is connected between the rectifier **10** and the inverter **12**. The output from the DC/AC inverter **12**, connects to an electron-trap **14** which can extract electrons from space (as described in Brazilian patent application No. BR1020120008378 of 13th January 2012) or alternatively, extracts electrons from the Earth (as described in Brazilian patent application No. BR1020120008386 of 13th January 2012).

When connected, the battery bank **13** provides power to the DC/AC inverter **12** which converts the direct current into alternating current and provides current to the electron-trap **14**. The output of the electron trap **14** is passed through wire **18**, to the AC/DC bridge rectifier **10**, which keeps the battery bank charged as well as powering the DC/AC inverter **12**. Additional power is passed to external equipment through wire **17**.

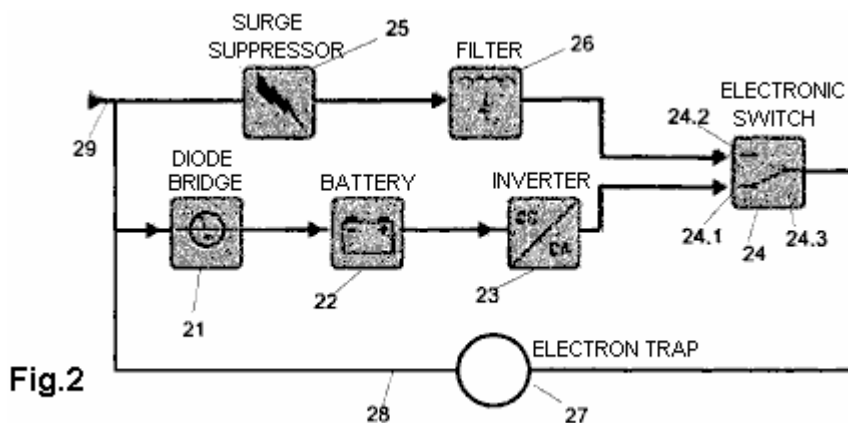

Fig.2

Fig.2, shows another embodiment of the system of this self-powered electric power generation equipment. It comprises a typical Uninterruptible Power Supply circuit of a battery charger (AC/DC converter) **21** connected to a drive device (a DC/AC inverter) **23** and between them, a battery bank **22** forming the basic circuit. Additional devices are an electron-trap **27** which may collect free electrons from space (as defined in Brazilian patent application No. BR1020120008378 of 13th January 2012) or, alternatively, collects electrons from the Earth (as described in Brazilian patent application No. BR1020120008386 of 13th January 2012). The 3-phase electronic switch **24** normally connects **24.1** to **24.3** connecting the electron trap **27** to inverter **23**. Connected in parallel is the surge suppressor **25**, which, when activated, via filter **26**, causes switch **24** to disconnect the **24.3** to **24.1** link and instead, connect **24.3** to **24.2**.

An alternative arrangement for use in emergency situations, is to use the system no longer self-powered. For this, the system is comprised of a power input from an external power source, directly to the interconnection point **29** to provide power to surge suppressor **25**, which provides power to feed the power output point **28** in order to power external loads. When the electron-trap **27** is turned off, the electronic transfer switch **24** reverts to its default position which connects point **24.1** to point **24.3** causing the circuit to function, once again, in its self-feeding mode. As soon as the electron sensor **27** provides sufficient power to the over-voltage sensor **25**, it operates the transfer switch **24** through filter **26**, ending the self-feeding phase and supplying energy directly to the power output point **28**, in order to feed external loads.

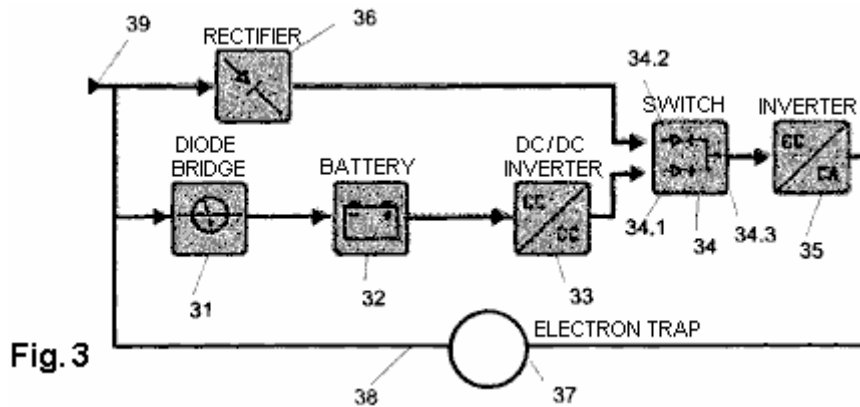

Fig. 3

Fig.3 shows another embodiment of the self-powered system for generating electricity, comprising a device which includes the basic circuit of a typical Uninterruptible Power Supply, consisting of a battery charger (AC/DC converter) 31 connected to a drive device (inverter DC/AC) 35 and attached to them, a battery bank 32. This basic circuit together with other devices is connected to an electron-trap 37 for collecting free electrons from surrounding space or, alternatively, an Earth-connected electron trap 37. We have then, a bank of batteries 32 connected to the DC/DC converter 33, which is connected to the phase transfer switch 34 / 34.1 which is connected to point 34.3, which connects to the inverter 35, and so, the electron-trap 37.

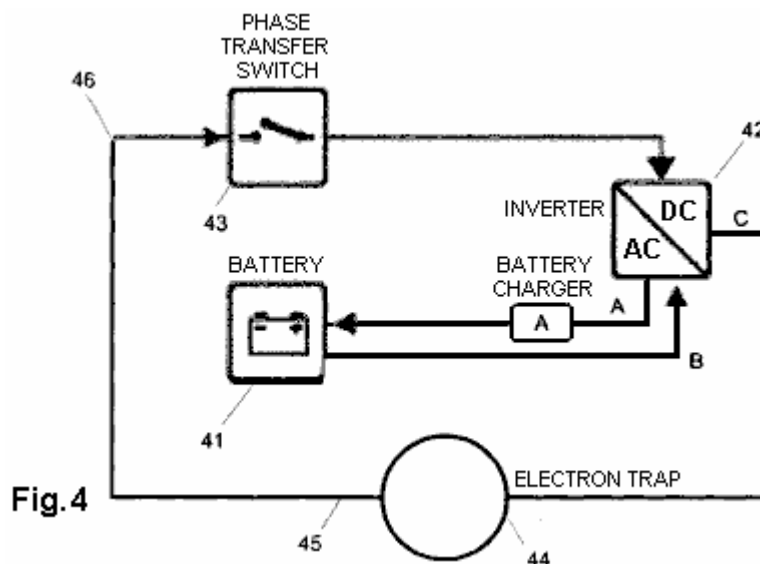

Fig. 4

Fig.4 shows another embodiment of the system for self-powered electricity generation which is comprised of a basic circuit of a typical uninterruptible power supply, consisting of a battery charger (AC/DC converter) A connected to an inverter (DC/AC) 42 and attached to them, battery bank 41, and this basic circuit together with other devices are connected to a free space electron-capture device 44 or an earth-connection electron-trap 44. Comprising thus, a battery charger A connected to a battery bank 41, which is connected in series with inverter 42 at point B which is in series with point C of inverter 42 which is in series with the electron sensor 44, which is in series with the phase transfer switch 43 via the three-phase load output connection point 45. The phase transfer switch 43 is in series with the inverter 42, which is connected in series the (AC/DC converter) battery charger A feeding the battery bank 41.

An alternative construction for use in emergency situations, in which the system ceases to be self-powered, the system may include power input from an external power source, via the interconnection point 46, thus providing electricity output 45, to power external loads. The battery bank 41 provides power to the inverter 42 which converts the direct current into alternating current and feeds the electron trap 44. The phase transfer switch closes when the batteries need recharging.

Sensor 44 captures electrons, producing alternating current, which feeds the phase transfer switch 43 with alternating current input power. The phase transfer switch 43 feeds the inverter 42 which charges the batteries, closing the self-powering loop which provides power at the output 45, feeding both the power input and any external loads.

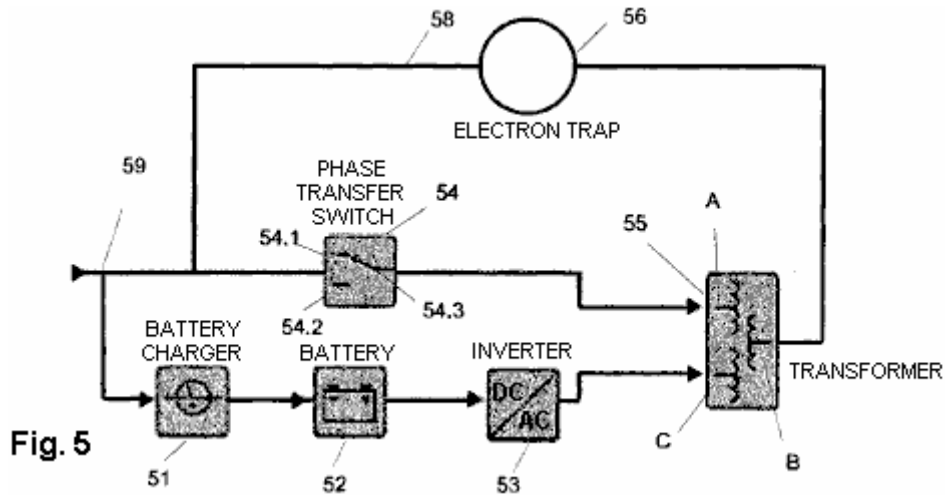

Fig.5 shows another embodiment of the system for self-powered electric power generation equipment comprising a circuit which includes a typical uninterruptible power supply comprising a battery charger (AC/DC converter) **51** connected to a DC/AC inverter **53** and attached to them, a battery bank **52**. This basic circuit together with other devices are connected to a space free-electron capture device **56** (as defined in Brazilian patent application No. BR1020120008378 of 13/1/12) or, alternatively, an earthed free-electron collector **56** (as defined in Brazilian patent application No. BR1020120008386 of 13/1/12). This then comprises a battery charger **51** which is connected in series with a battery bank **52**, which is connected in series with the inverter **53**, which is connected in series with the transformer **55** at its point **C**, which is in series with its point **B** which is in series with the electron collector **56**, which is in series with the battery charger **51** which is connected to the load exit point **58**, which is also the circuit entry point **59**, which is in series with the phase transfer switch **54** section **54.1**, which is connected to terminal **54.3**, which is in series with point **A** of the transformer **55** which exits at point **B**. Points **A** and **54.3** as well as the parallel points **54.1** and **54.2**, are all parallel to the battery charger **51**, the battery bank **52**, the inverter **53** and to point **C** of the transformer **55**.

An alternative construction for use in emergency situations, in which the system ceases to be self-powered, the system may include an external power input point **59**, allowing phase transfer switch **54** to provide power output **58**, to feed external loads. Battery bank **52** provides power to the inverter **53**, which converts the direct current into alternating current, feeding point **C** of the transformer, which comes out at points **B** and **A** of the transformer **55**. Point **B** of the transformer feeds the electron-trap **56** producing alternating current which feeds the battery charger **51**, recharging the battery bank **52**.

The battery charger **51** is connected in parallel with the transfer switch **54** via connection points **54.1** and **54.3**, feeding point **A** of the transformer, which comes out at point **B**. Point **A** of the transformer and the switch transfer points **54.3** and **54.1** are in parallel to the battery charger **51**, the battery **52**, the inverter **53** and point **C** of the transformer **55**.

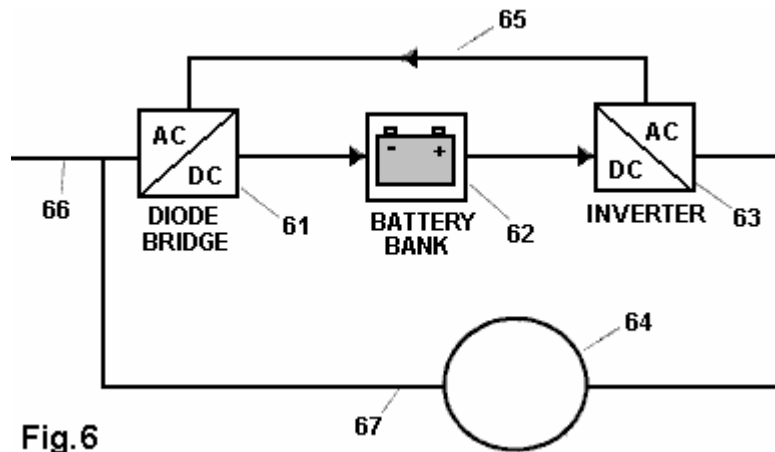

Fig.6 shows another embodiment where a rectifier **61** is connected to an inverter **63** and a battery bank **62**, and to a space free-electron trap **64** or alternatively, an earth electron trap **64** comprising thus, a delta (AC/DC) converter **61**, which is connected in series to a battery bank **62**, which is connected in series with the (DC/AC)

inverter **63**, which is in series with the electron collector **64** which is connected in series with the delta converter (AC/DC) **61** whose AC part is in series with the alternating AC current inverter **63** via a connecting wire **65** which is in parallel with the DC part of the delta converter **61** with the battery bank **62** and the DC part of inverter **63**. An alternative construction for use in emergency situations, in which the system ceases to be self-powered, the system may comprise a power input from an external power source, via the interconnection point **66** connected to the delta converter **61**, the output **67** supplying power, to the external loads.

Battery bank **62** provides power to the inverter **63**, which converts the direct current into alternating current, powering the free-electron collector **64**. The captured electrons from collector **64** form an alternating current which feeds the delta converter **61** via an output power load wire **67**.

The alternating part of the three-phase delta converter **61** is fed with alternating current from inverter **63** via connecting wire **65**, which is connected in parallel to the continuous DC delta converter **61**, which feeds the battery bank **62** and with the continuous portion the inverter **63**, closing the cycle of self-feeding and supplying power at the output **67**, which is the output power point.

Having described examples of preferred embodiments, it should be understood that the scope of the present invention encompasses other possible forms of construction, using the electron collectors connected to a basic circuit of a typical uninterruptible power supply of energy, known as a UPS, comprising a rectifier device (an AC/DC converter) **10**, connected to one inverter (DC/AC converter) **12**, and attached between them, an energy storage device (typically, a battery bank).

A very important part of the above patent is the device described as a “collector of free-electrons”, either from the earth or from space. We have to go to the patent applications mentioned above to find the details of these designs:

Assignee: EVOLUÇÕES ENERGIA LTDA (Rua Santa Tereza 1427-B Centro - Imperatriz, MA- CEP -470 - Maranhão, 65900, BR)

ELECTROMAGNETIC ELECTRON TRAP FOR ELECTRIC POWER GENERATION

Technical Field

The present invention refers to electromagnetic equipment for electric power generation or alternatively for thermal power generation. More specifically equipment capable of producing abundant electricity and thermal energy from a tiny amount of input electrical energy

Description of the Related Art

According to Lenz's law, any induced current has a direction such that the magnetic field it generates opposes the change in magnetic flux which produced it. Mathematically, Lenz's Law is expressed by the negative sign (-) that appears in the formula of Faraday's Law, as follows.

The magnitude of the induced emf (ε) in a conducting loop is equal to the rate of change of magnetic flux (Φ_B) with time:

$$\varepsilon = - \frac{d\Phi_B}{dt} \quad \text{Equation 1}$$

As an example of application of Faraday's Law, we can calculate the electromotive force induced in a rectangular loop that moves in or out, with constant speed, a region of uniform magnetic field. The magnetic field flux through the surface limited by the loop is given by:

$$\phi = xLB \quad \text{Equation 2}$$

and its variation in time:

$$\frac{\Delta\phi}{\Delta t} = \left(\frac{\Delta x}{\Delta t}\right)LB = vLB \quad \text{Equation 3}$$

So:

$$\varepsilon = vLB \quad \text{Equation 4}$$

and if the coil has a resistance (R) and the induced current:

$$i = \frac{\varepsilon}{R} = \frac{vLB}{R} \quad \text{Equation 5}$$

A conductor traversed by an electric current immersed in a magnetic field undergoes the action of a force given by:

$$F = IL \times B \quad \text{Equation 6}$$

Thus, the effect of the current induced in the loop appears as forces F_f , and $F - FM$. The first two cancel each other out and the third is cancelled by an external force P_{EXT} needed to maintain the constant speed loop.

As the force FM must oppose the force F_{EXT} , current (i) induced in the loop by varying the magnetic flux must have the meaning indicated in **Fig.3**. This fact is a particular example of Lenz's Law.

Considering the experimental activities discussed with Faraday's law, when a magnet approaches a coil, the induced current in the coil has a direction as shown in **Fig.1**. This generates a magnetic field whose north pole is facing the north pole of the magnet, that is, the field generated by the induced current opposes the motion of the magnet.

When the magnet is moved away from the coil, the current induced in the coil has a direction opposite to that shown in **Fig.1**, thereby generating a magnetic field whose south pole is facing the north pole of the magnet. The two poles attract each other, that is, the field generated by the induced current opposes the movement of the

magnet away from the coil. This behaviour is present in all current power generators, and known as 'engine brake' is highly undesirable as it increases the resistance and so, the energy loss.

When two electromagnetic coils are placed facing each other, as shown in **Fig.2**, there is no current in either of them. At the instant of power-up of one of the coils, the current in the coil, generates an induced current in the second coil. When powered up, the current in the coil goes from zero to its maximum value, and then remains constant.

Thus, when the current is changing, the magnetic field generated by it, (whose north pole faces the second coil) is also changing and so the magnetic flux of this field through the second coil is also changing. Then there is a current induced in the second coil whose sense is such that the magnetic field it generates tends to decrease the flow mentioned above, that is, its north pole confronts the north pole of the first field coil.

When the power switch is opened, the current in the first coil drops from its maximum value to zero, and correspondingly its magnetic field decreases. The flux of the magnetic field in the second coil also decreases, and the induced current now flows in the opposite direction. This current flow direction produces an enhancing magnetic field, that is, it has a south pole facing the north pole of the field of the first coil.

Thus, there is a realisation of the principle of conservation of energy, expressed by Lenz's law, wherein any induced current has an effect which opposes the cause that produced it. Assuming that the induced current acts to favour the variation of the magnetic flux that produced the magnetic field of the coil, it would have a south pole facing the north pole of the approaching magnet, causing the magnet to be attracted towards the coil.

If the magnet were then released, it would experience an acceleration toward the coil, increasing the intensity of the induced current and thus create an enhanced magnetic field. This field, in turn, would attract the magnet with increasing force, and so on, with a continuing increase in the kinetic energy of the magnet.

If energy were to be withdrawn from the magnet-coil system at the same rate at which the kinetic energy of the magnet increases, then there would be an endless supply of energy. So it would be a perpetually operating motor, which would violate the principle of conservation of energy. Therefore, it can be concluded that current generators feature a large energy loss during the generation of electricity.

Objectives of the Invention

An objective of the present invention is to contribute to the generation of sustainable energy, proposing an electromagnetic machine capable of producing abundant electricity from an extremely low input of electrical energy.

The above objective and other objectives are achieved by the present invention by a device comprised of at least one electromagnetic field-generating device (without a core or with at least one core) powered by an electrical power source (without a core or with at least one core) having their coils, or sets of coils, wound on at least one common conductive member in a closed circuit which itself has a polarised voltage which is connected to at least one conductive interconnection element which is connected to a grounding grid, these interconnections creating a new technical effect, namely, the appearance of an electric current which keeps circulating in a closed conductive loop, and which can therefore be used to power external loads.

The device which is the object of the present invention operates as follows: the electromagnetic field generating device, powered by a power source, produces an electromagnetic field which induces an electric current in a closed conductive circuit, creating an interaction between the magnetic poles of the equipment and the magnetic poles of the earth - through both electromagnetic attraction and repulsion. An endless supply of electrons is drawn from the earth into the conductive closed loop, which is connected to the ground through a conductive interconnected grid. Attracted electrons add to the current already flowing in the conductive closed loop, making power available for driving high-power loads, although the device itself is only supplied with a small amount of power. Thus, advantageously, the device which is the object of the present invention, acts as a trap for electrons from the earth and this allows the generation of electricity.

Advantageously, the present electromagnetic equipment generates either electricity or thermal energy, providing access to this new source of energy is through an electromagnetic field. The interconnections of the components of the electron-trap of the present invention, cause an advantageous new technical effect, namely, the appearance of an electric current which keeps circling in the conductive closed circuit, with or without voltage being applied and even without a load being connected to the loop - provided that the electron-trap is connected.

The proposed sensor can also be used to generate thermal power, depending on the form in which you want to use the effect of the flow of electrical current produced in this electromagnetic equipment.

For the generation of thermal energy in amounts proportional to the power of the electron-trap, through the movement of electrons in the conductive closed loop itself, the resistance should be increased by increasing the number of turns around the cores in the conductive element of the closed circuit, and in that instance, the coils of the electromagnetic field generating device, will then be made of heat-insulated electrical circuit components, bearing in mind the required temperature which is to be produced. The thermal energy generated by the electron-trap can be used in any application from domestic to industrial applications.

This technology can also be used for various technical purposes in electric machines. By "electrical machines", it should be understood to include: static electrical machines, transformers, ballasts, rotating electrical machines, synchronous machines, dual power supply machines, current rectifiers in synchronous cascade, external pole machines, synchronous current machines alternating current machines and/or direct current machines, electronic equipment and electrical resistances. The capture of electrons can provide single-phase, two-phase or three-phase supplies, operating at low, medium or high voltage.

The capture of electrons by induction, does not impact on the environment. The fact is that we use as the capturing force, only a negligible amount of electricity relative to the current captured by the sensor. The relationship between power input and the quantity of electricity generated by the electron-trap is at least 1 to 100, that is, for each 1 watt provided to the sensor, there is at least 100 watts of power available for external loads. This relationship, however, is not limited, as it depends on the mounting of the electron-trap and the objectives of the circuit, and so, the generated power can be greater than 100 times the input power.

Another advantage of the earthed electron- trap proposed in the present invention is that the electron-trap can transport electrons from point "A" to point "B" without a voltage drop across the closed-loop conductive element - if it is biased with a voltage - regardless of the distance between the points depending on the strength and quantity of the electromagnetic field generating devices. It is also possible to transport electrons when the conductive element in a closed circuit is itself not polarised. Thus, the electric current is transported without voltage, just by the magnetic field formed between the device and the generator of the electromagnetic field.

Brief description of the Drawings

The present invention will now be described with the aid of drawings, but the design is not limited to the implementations shown in these drawings, although they show other details and advantages of the present invention.

The figures show:

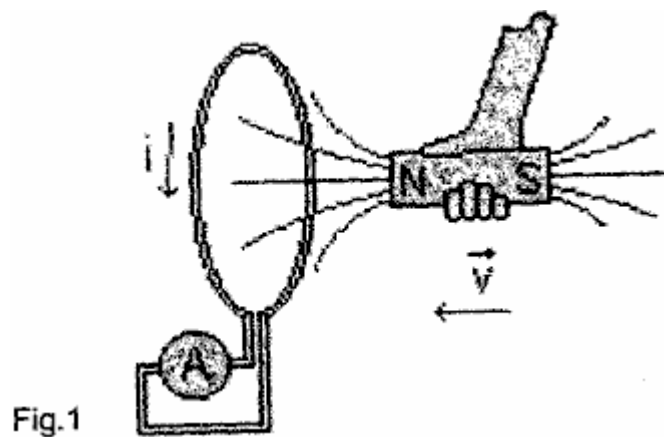

Fig.1 - illustrates Faraday's law.

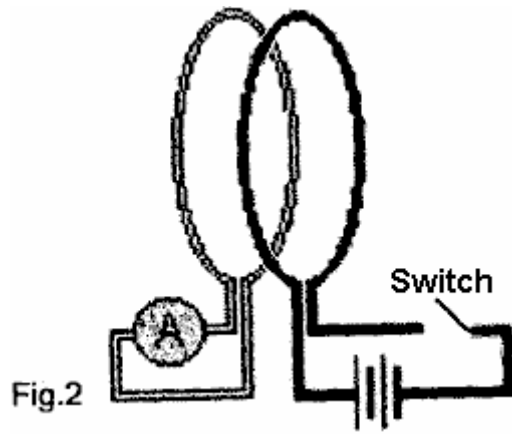

Fig.2 – is a representation of Faraday's law.

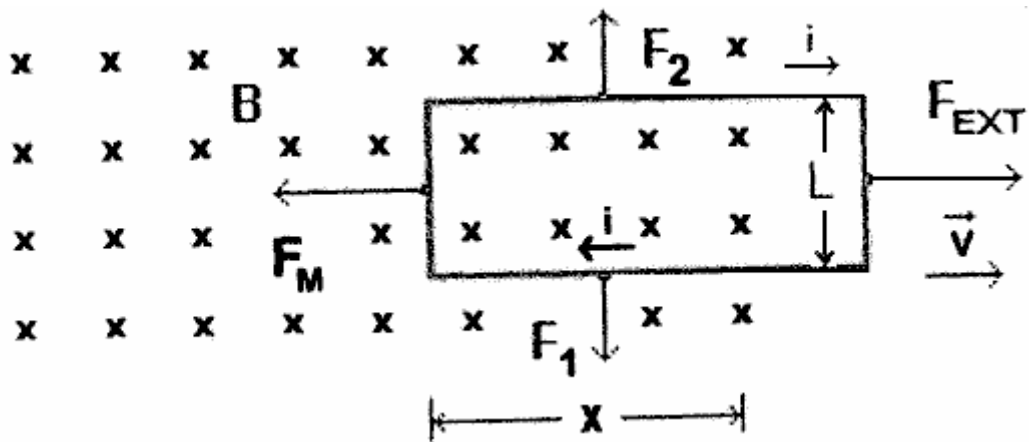

Fig. 3 – is a representation of Faraday's law.

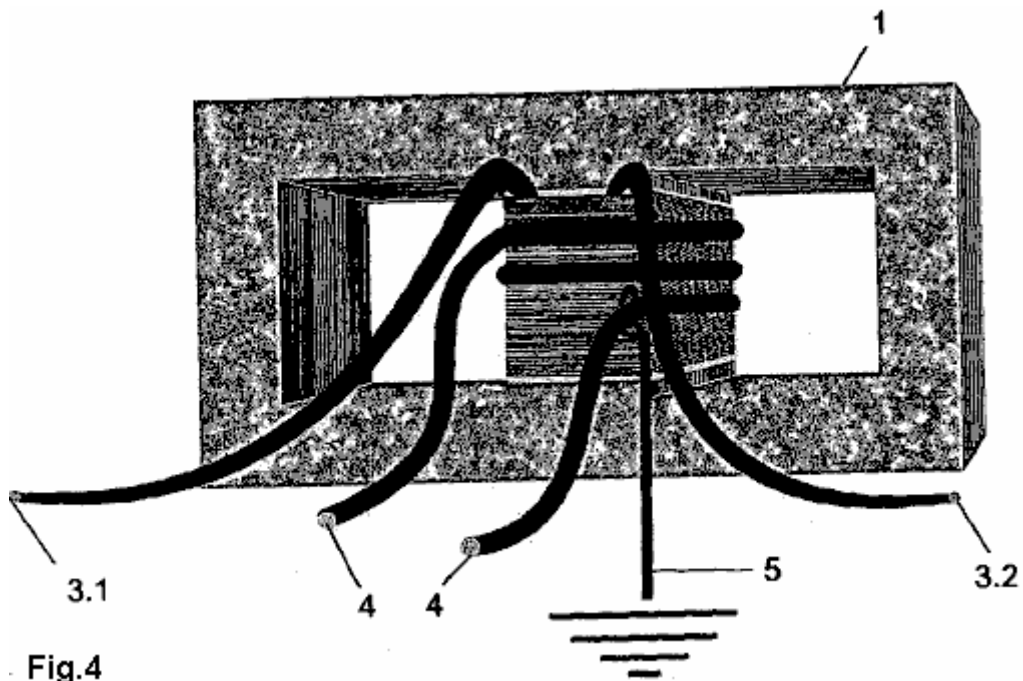

Fig. 4 - is a perspective view of an electron-trap with a single phase coil.

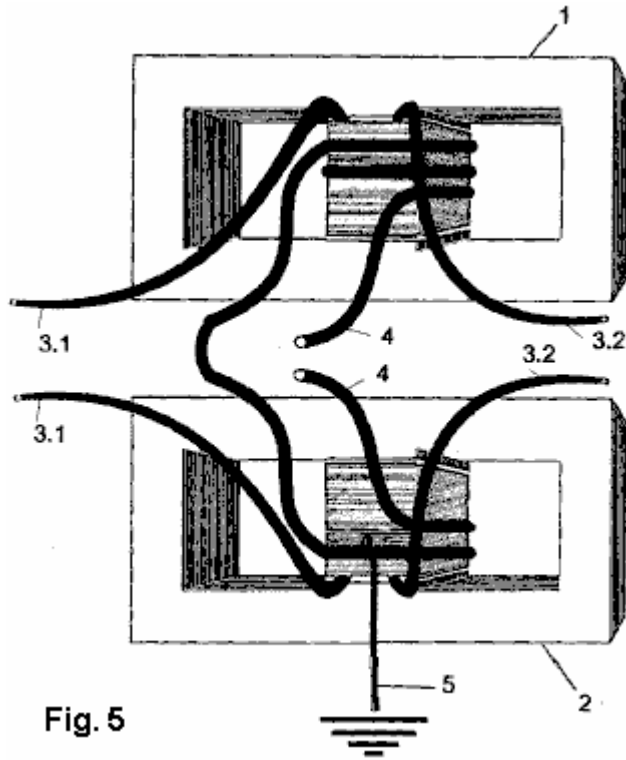

Fig. 5

Fig.5 – is a perspective view of a single-phase electron trap with two coils.

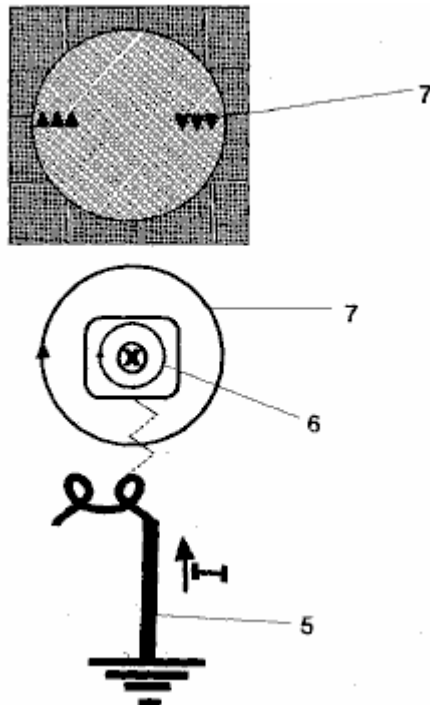

Fig. 6

Fig.6 - is a representation of the effect of electromagnetic flux in the coils around the cores of the electron trap.

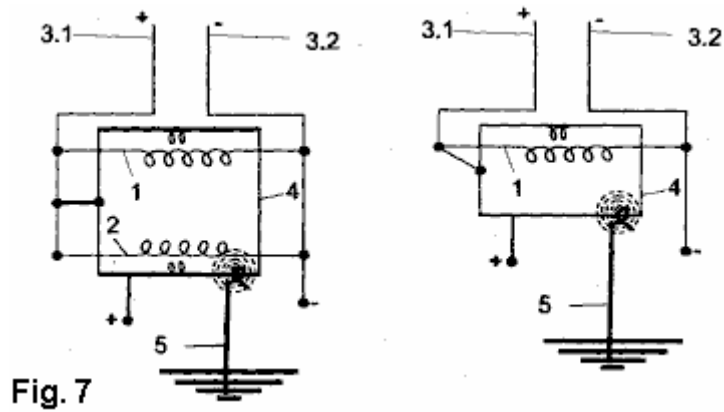

Fig.7 - is a representation of an electrical circuit with two coils of the link/coil conductor polarised.

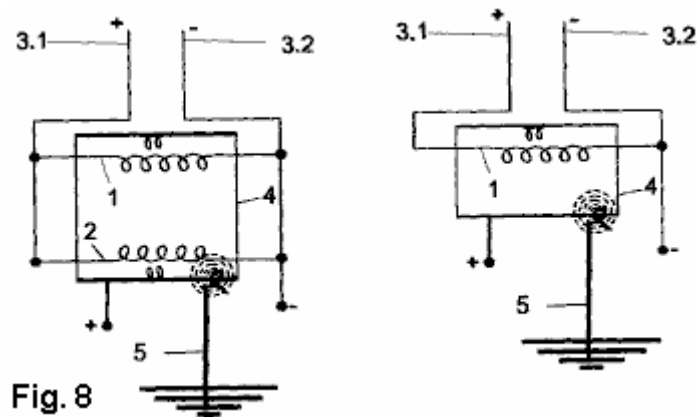

Fig.8 - is a representation of an electrical circuit with two coils of the link/coil conductor not polarised.

Detailed Description of the Drawings

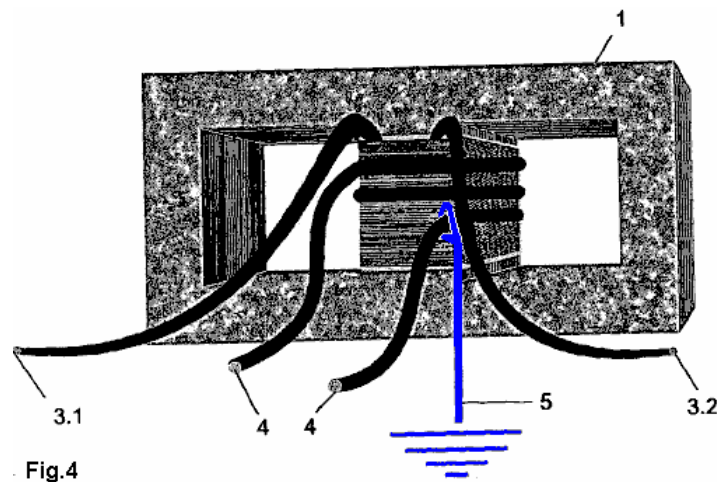

Fig.4 shows one of several types of electron-trap proposed by the present invention, where the electron-trap is single-phase and consists of at least one electromagnetic field-generating device with at least one set of coils, in this case it happens to be an electromagnetic type coil with one common magnetic core, but it could alternatively have any number of windings of any kind and shape. However, the electron-trap proposed by the present invention can be constructed with a different type of electromagnetic field generating device, such as an electromagnetic inductor or magnet of any type or shape, or any combination of them, and in unlimited numbers for each phase of the electron trap.

When winding these coils, for example, coil 4-4, each coil must have at least one complete turn, preferably two turns if the objective is to generate electricity, and preferably four turns if the objective is provide thermal energy. The number of turns in the coils wound around the common core, is directly related to the amount of current to be generated.

At least one conductive interconnection element, in this case the driving member 5 - which can be copper or any other suitable conductive, material whether insulated or not insulated, connects or loop-links wire 4 to the ground grid. The connection between the conductor 5 and wire 4 is by electromagnetic induction. Winding 4 is also the power supply for the loads which are to be powered by the captured electrons.

Also in Fig.4, the power wires 3.1 and 3.2 (live phase and neutral) have an input from an external power coil 1 which can be energised from any external source of electricity such as a power grid. The trapped electrons can be configured to supply DC or AC current. Thus, if the coil 1 power source is alternating electrical current - AC, then the electron-trap provides alternating electrical current. If the power source is continuous electrical current - DC, then the electron-trap provides continuous electrical current - DC. The electrical supply provided by the trapped electrons can be single-phase, two-phase or three-phase, and at low, medium or high voltage.

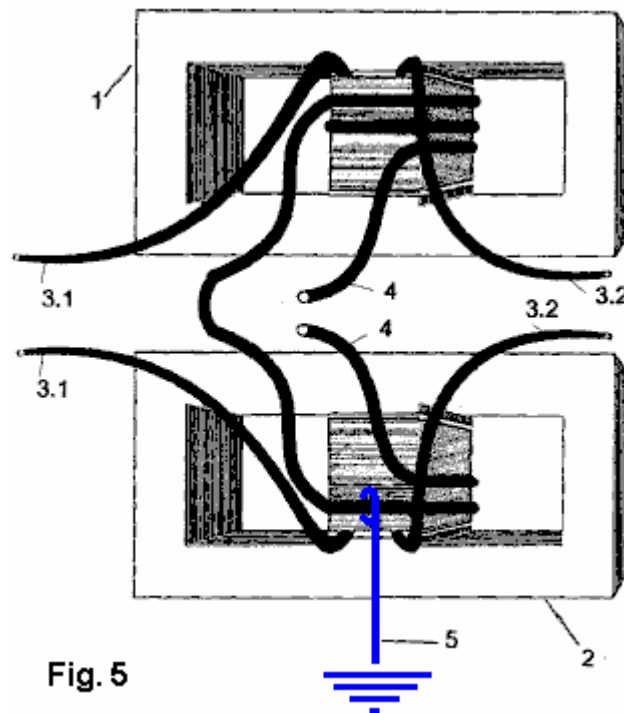

Fig.5 shows an electron-trap with two single-core phase coils: 1 and 2, although these coils may be of any type and shape. However, the electron-trap proposed by the present invention can be constructed with other types of electromagnetic field generating device, with at least one electromagnetic inductor or electromagnet which can be of any type and shape, with any combination of them, and in unlimited quantities in each phase of the electron-trap.

The coils on frames 1 and 2 may have other shapes, but they must each have at least one complete turn, particularly in coil 4. The number of turns in this winding are directly related to the amount of current to be generated. This coil also makes the interconnection between the coils 1 and 2 forming the link between their two cores.

At least one conductive interconnection element, in this case the driving member 5 - which can be copper or any other suitable conductive, material whether insulated or not insulated, connects or loop-links wire 4 to the ground grid. The connection between the conductor 5 and wire 4 is by electromagnetic induction.

In electron-traps which have numerous sets of coils 1 and 2, the ends of all of the power-supply conductors 3.1 can all be connected to each other, and all of the 3.2 conductor ends may be connected together. Thus, all of the coils 1 and 2 can be fed exactly the same voltage. The power to energise coils 1 and 2 can be provided from any external source of supply of electricity such as a power grid.

In electron-traps which have numerous coils 1 and 2, a single coil winding 4 connects the cores of all of the coils 1 and 2.

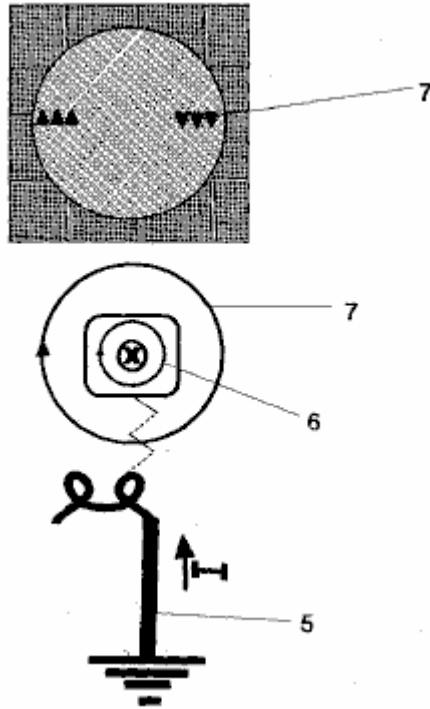

Fig. 6

The diagram shown in Fig.6, illustrates the magnetic induction 6 around the core "X" of the coil 1. This induction causes electrical current flow in the conductor coil link 7/4, attracting electrons from the earth, through the conductive member 5, to the magnetic field of the electron-trap, where those electrons are added to the current generated by induction in the link coil 4 conductor loop circulating between north and south magnetic poles.

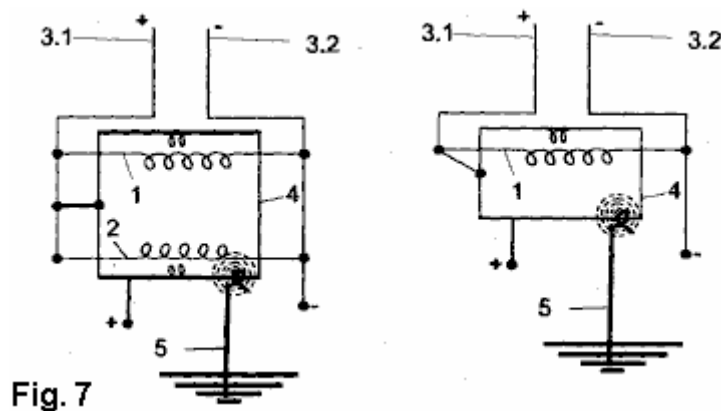

Fig. 7

Fig.7 shows how the connections should be made in one version of the electrical circuit of the electron-trap proposed in this invention. The diagram shows the electrical circuit of an electron-trap where the link/coil driver 4 is polarised with a voltage. This is one form of construction for an electron-trap which has two coils 1 and 2, where a link/coil loop conductor 4 is biased with a voltage, that is, there is a link connecting the coil conductors 4 of a power supply 3.1 or 3.2, whatever the stage.

In this way, earth electron-traps, by adopting this circuit, that is, with the link/conductor loop 4 and polarised voltage on coils 1 and 2, besides being used as a power source for external loads, can also be used for thermal power generation.

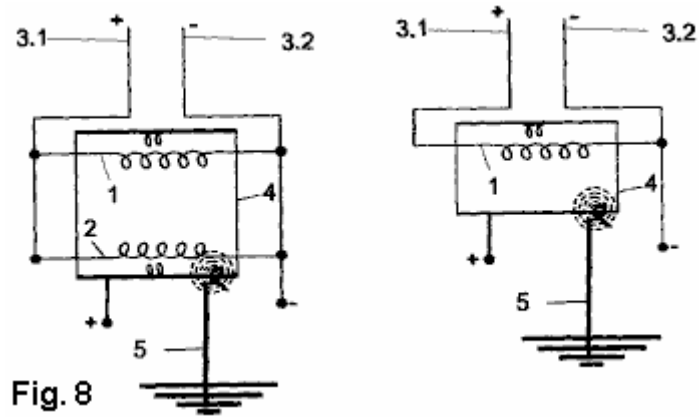

Fig. 8

Fig.8 shows how connections should be made in another electric circuit electron-trap proposed in this invention. the circuit illustrates a circuit of an electron-trap with a non-polarised link / coil driver **4**. This is one form of construction of the electron-trap where a link / coil conductor **4** of the spiral conductor coils **1** and **2** is not polarised, that is, there is no such link connecting conductor / conductor coil conductors **4** of a coil **3.1** or **3.2**.

Thus, earth electron-traps adopting this circuit, that is, with the link coil not polarised, the current flows without there being voltage in the link/coil conductor **4** joining the first and second coils by electromagnetic induction. They can also be used for generating thermal energy.

The structure of the circuit - in the open or closed coils **1** and **2**, and always in the closed link / loop lead **4** - makes it possible to generate current by induction and electron capture by electromagnetism on the link conductor **4** - where current is generated and stays in motion with or without voltage, as the coils **1** and **2** are being fed. Thus, the present invention provides a new concept for electrical energy generation, since it is obtained from an electric current circling without consumption and even without an output load being attached to it.

Additionally, because the induced electrical current flows regardless of the voltage present, it can be used as a current stabiliser for electrical networks whether they be single-phase, two-phase or three-phase, with low, medium or high voltage.

ELECTROMAGNETIC DEVICE FOR CAPTURING FREE SPACE ELECTRONS TO GENERATE ELECTRICITY

Application Number: BR2013/000014

Publication Date: 07/18/2013

Filing Date: 01/11/2013

Assignee: EVOLUÇÕES ENERGIA LTDA (Rua Santa Tereza 1427-B Centro - Imperatriz -, MA - CEP -470 - Maranhão, 65900, BR)

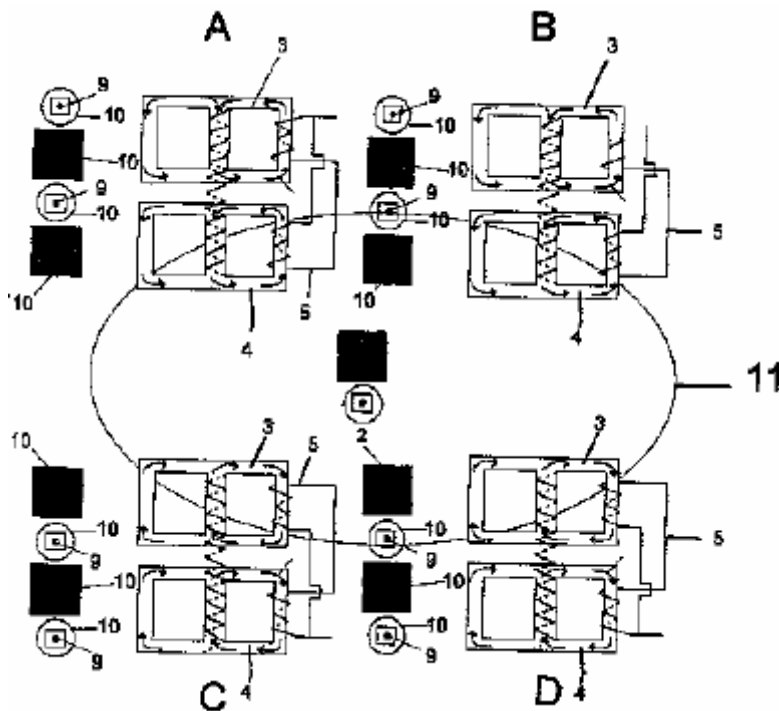

Abstract:

The invention relates to a device that comprises at least three sets (A, B, C, D) of at least one device for generating an electromagnetic field (3) and (4), powered by an electricity source (without a core or with at least one core) the cores thereof or any extension thereof, preferably the windings or sets of windings thereof, being surrounded by at least a single conductive element forming a polarised and energised closed-circuit (5), the sets of electromagnetic-field generating devices (3) and (4) being linked together by their opposing poles to encourage the interaction of their electromagnetic fields, which ideally, are located between two hollow metal hemispheres (1) so as to concentrate and enhance the electromagnetic fields, these interconnections causing, as a novel technical effect, the emergence of an electrical current that circulates, with or without voltage, in the conductive element forming a closed-circuit (5) - even if no load is connected.

Description:

"ELECTROMAGNETIC EQUIPMENT FOR FREE ELECTRON-CAPTURE FROM SPACE, FOR ELECTRICITY GENERATION".

Technical Field

The present invention relates to electromagnetic equipment for electrical power generation and/or thermal power generation. More specifically, equipment capable of producing abundant electricity and thermal energy from a tiny input of electrical energy.

Description of the Related Art

According to Lenz's law, any induced current has a direction such that the magnetic field it generates opposes the change in magnetic flux that produced it. Mathematically, Lenz's Law is expressed by the negative sign (-) that appears in the formula of Faraday's Law, as follows.

The magnitude of the induced emf (ϵ) in a conducting loop is equal to the rate of change of magnetic flux (Φ_B) with time:

$$\epsilon = - \frac{d\Phi_B}{dt} \quad \text{Equation 1}$$

As an example of application of Faraday's Law, we can calculate the electromotive force induced in a rectangular loop that moves in or out, with constant speed, a region of uniform magnetic field. The magnetic field flux through the surface limited by the loop is given by:

$$\phi = xLB \quad \text{Equation 2}$$

and its variation in time:

$$\frac{\Delta\phi}{\Delta t} = \left(\frac{\Delta x}{\Delta t}\right)LB = vLB \quad \text{Equation 3}$$

So:

$$\epsilon = vLB \quad \text{Equation 4}$$

and if the coil has a resistance (R) and the induced current:

$$i = \frac{\epsilon}{R} = \frac{vLB}{R} \quad \text{Equation 5}$$

A conductor traversed by an electric current immersed in a magnetic field undergoes the action of a force given by:

$$F = IL \times B \quad \text{Equation 6}$$

Thus, the effect of the current induced in the loop appears as forces F_f , and $F - FM$. The first two cancel each other out and the third is cancelled by an external force P_{EXT} needed to maintain the constant speed loop.

As the force FM must oppose the force F_{EXT} , current (i) induced in the loop by varying the magnetic flux flux must have the meaning indicated in **Fig.1**. This fact is a particular example of Lenz's Law.

Considering the experimental activities discussed with Faraday's law, when a magnet approaches a coil, the induced current in the coil has a direction as shown in **Fig.2**. This generates a magnetic field whose north pole is facing the north pole of the magnet, that is, the field generated by the induced current opposes the motion of the magnet.

When the magnet is moved away from the coil, the current induced in the coil has a direction opposite to that shown in **Fig.2**, thereby generating a magnetic field whose south pole is facing the north pole of the magnet. The two poles attract each other, that is, the field generated by the induced current opposes the movement of the magnet away from the coil. This behaviour is present in all current power generators, and known as 'engine brake' is highly undesirable as it increases the resistance and so, the energy loss.

When two electromagnetic coils are placed facing each other, there is no current in either of them. At the instant of power up one of the coils, the current in the coil, generates an induced current in the second coil. When powered up, the current in the coil goes from zero to its maximum value, and then remains constant.

Thus, when the current is changing, the magnetic field generated by it, (whose north pole faces the second coil) is also changing and so the magnetic flux of this field through the second coil is also changing. Then there is a current induced in the second coil whose sense is such that the magnetic field it generates tends to decrease the flow mentioned above, that is, its north pole confronts the north pole of the first field coil.

When the power switch is opened, the current in the first coil drops from its maximum value to zero, and correspondingly its magnetic field decreases. The flux of the magnetic field in the second coil also decreases,

and the induced current now flows in the opposite direction. This current flow direction produces an enhancing magnetic field, that is, it has a south pole facing the north pole of the field of the first coil.

Thus, there is a realisation of the principle of conservation of energy, expressed by Lenz's law, wherein any induced current has an effect which opposes the cause that produced it. Assuming that the induced current acts to favour the variation of the magnetic flux that produced the magnetic field of the coil, it would have a south pole facing the north pole of the approaching magnet, causing the magnet to be attracted towards the coil.

If the magnet were then released, it would experience an acceleration toward the coil, increasing the intensity of the induced current and thus create an enhanced magnetic field. This field, in turn, would attract the magnet with increasing force, and so on, with a continuing increase in the kinetic energy of the magnet.

If energy were to be withdrawn from the magnet-coil system at the same rate at which the kinetic energy of the magnet increases, then there would be an endless supply of energy. So it would be a perpetually operating motor, which would violate the principle of conservation of energy. Therefore, it can be concluded that current generators feature a large energy loss during the generation of electricity.

Objectives of the Invention

The present invention aims to contribute to the generation of sustainable energy, proposing electromagnetic equipment capable of producing abundant electricity from an extremely low input of electrical energy.

The above objective and other objectives are achieved in the present invention by a device comprising at least three sets of at least one electromagnetic field generating device (without a core or with at least one core) powered by an electrical power source, having their cores or any extension of them, with their coils or sets of coils, wound on at least one common conductive member in a closed circuit which is polarised by a voltage source, and these sets of electromagnetic field generating devices are arranged with their poles in confrontation, to promote the interaction of electromagnetic fields, and, preferably, positioned between two hollow metallic hemispheres, in order to focus and enhance their electromagnetic fields - these interactions cause a new technical effect - the emergence of an electric current which keeps flowing in a closed loop, with or without voltage being applied to that closed loop, current which is capable of powering external loads - even if no load is attached to it.

The device which is the object of the present invention operates as follows: Sets of electromagnetic field generating devices to be powered by an electrical power source, produce an electromagnetic field which induces an electric current in a closed conductive circuit, creating an interaction between the magnetic poles, and through repeated electromagnetic attraction and repulsion, provides an endless supply of electrons to the conductive closed loop itself.

The electrons attracted by this technique, augment the current flowing in the closed conductive loop, which provides the current to power external loads of high power, in spite of the fact that the device itself is supplied with only a small level of power. Thus, advantageously, the device which is disclosed in the present invention forms a trap for electrons from space, resulting in the generation of electricity. The interconnections of the components of the electron-trap cause, a new technical effect, namely, the appearance of an electric current which keeps circling in a closed circuit, even without any voltage being applied to the closed circuit, and even without a load being connected to it. The present electromagnetic equipment generates electricity or thermal energy, providing access to this new source of energy through the use of an electromagnetic field.

The proposed sensor can also be used for the generation of thermal energy depending on the form of circuit which is to be used, resulting from the flow of electric current produced by this electromagnetic equipment.

This field generates a flow of electric current induced by electromagnetic coils, which appears in the linking interconnecting devices generating electromagnetic fields with electromagnets, inductors or magnets. This chain operates in a manner favourable to the variation of the magnetic flux produced by the magnetic field in the electron-trap. Thus, it creates a north pole and a south pole, providing an endless supply of electric current without resistance between the links which interconnect the devices which are generating the electromagnetic fields. So, induced electric current is generated with or without voltage in the interconnection links of electromagnetic field-generating devices, depending on the connection method of the electrical circuit of the electron-trap.

The free-electrons collected by the space electron-trap can form alternating current (AC) or direct current (DC). The ratio of input power to output power is 1 to 100, that is, the generated power can be 100 times greater than the input power when there is at least one link / coil driver between the coils and the inductors or electromagnets. This relationship, however, is not limited to a factor of 100, as it depends on the shape of the electron-trap and its objective.

Another advantage of the free space electron-trap of the present invention is that, with thermal insulation of the components in the electric circuit, it is possible to produce thermal energy at low, medium or high temperature, through the movement of the electrons in the conductors, coils and/or electromagnets. The temperature generated is linked directly to the number of turns in the coils.

Thermal power generation performed by the sensor can be used for boiling and/or evaporation of liquids to be used in other types of energy generation, for example, replacing the use of coal and natural gas.

Another advantage of the proposed electron-trap of the present invention is that the electron-trap can transport electrons from one point "A" to a point "B", without a voltage drop in the link - if it is polarised - regardless of the distance between the points, depending on the strength and quantity of the electromagnetic field-generating devices. It is also possible to transport the electrons when the link devices generating the electromagnetic field are not polarised. In this way, the electric current is conveyed without voltage but only by the magnetic field formed between the coils. This methodology can be used in various fields.

Because of its simple construction, the electron-trap is a simple device which is compact, and performs low-cost power generation which can be used in all types of machinery, equipment and devices of all kinds, and many areas of application which require electricity in order to operate. The electron-trap can have single-phase, two-phase or three-phase output, and can generate electric current at low, medium or high voltage.

Brief description of the Drawings

The present invention will now be described with the aid of drawings, but the design is not limited to the implementations shown in these drawings, although they show other details and advantages of the present invention.

The figures show:

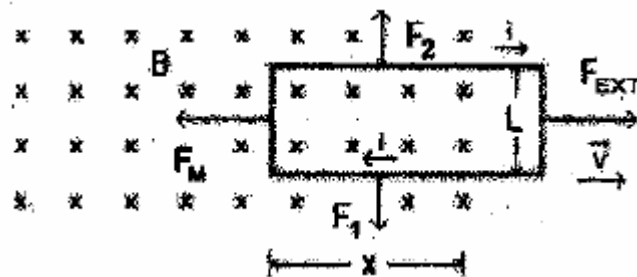

Fig.1 - illustrates Faraday's law.

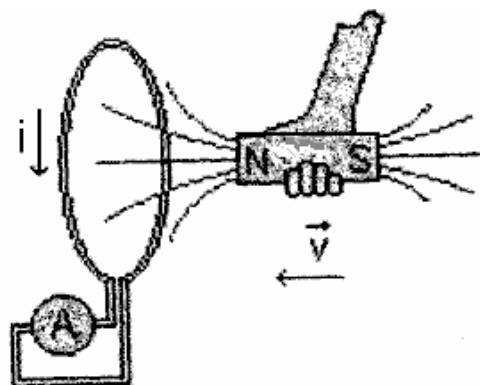

Fig.2 illustrates Faraday's law where a magnet approaches a coil of just one turn..

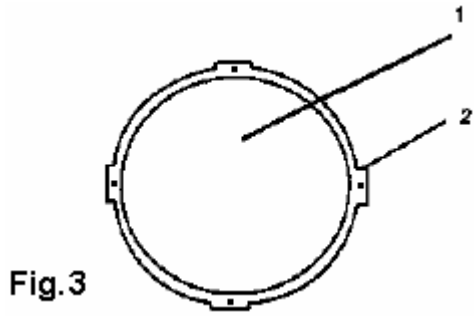

Fig. 3

Fig. 3 is a view of one metallic hemisphere seen from above.

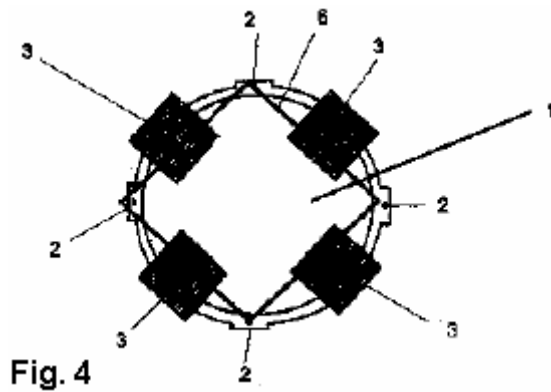

Fig. 4

Fig. 4 is a bottom view of the hemisphere with the coils in place.

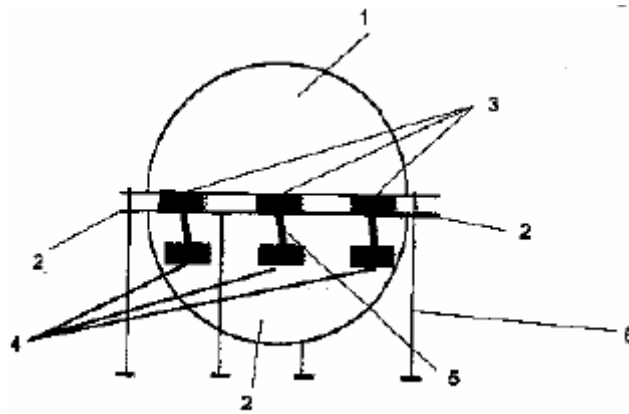

Fig. 5 is a side view of the free-space electron-trap.

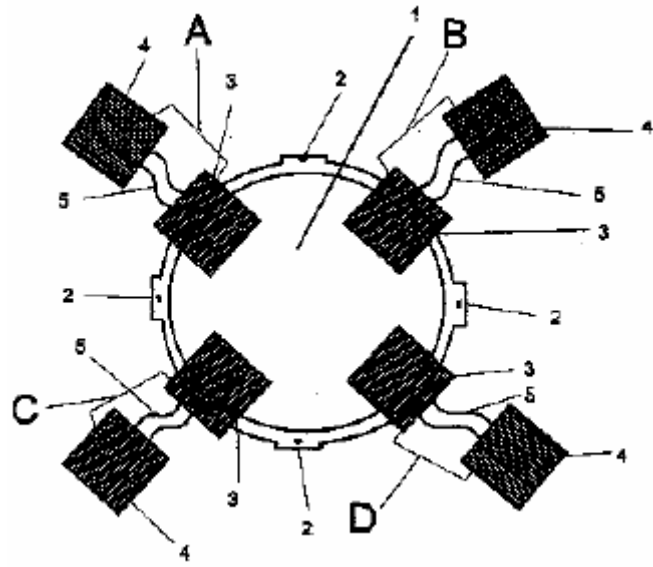

Fig.6 is an underside view of the space electron-trap, with its coils and electromagnets

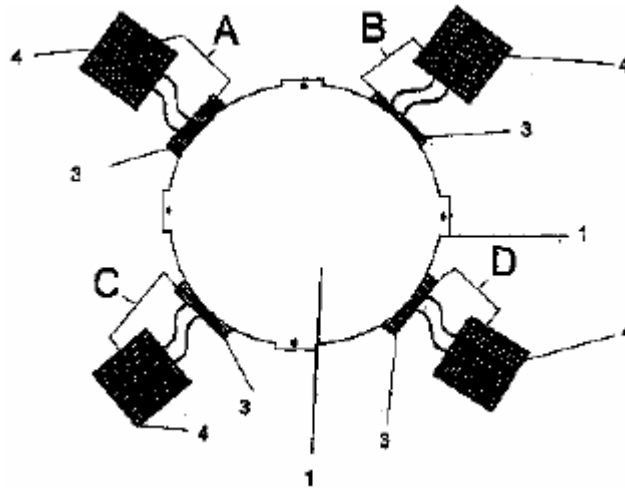

Fig.7 a view from above of the space electron-trap with its coils and electromagnets.

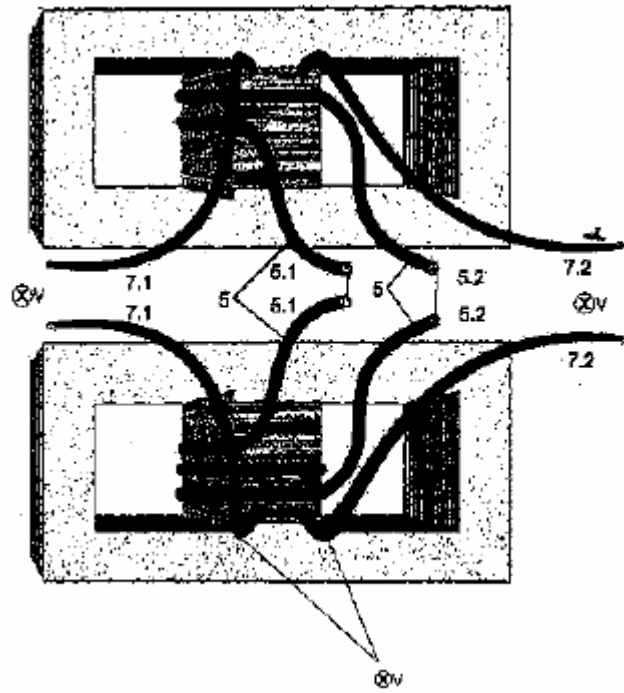

Fig.8 is a perspective view of an electron-trap with its coils.

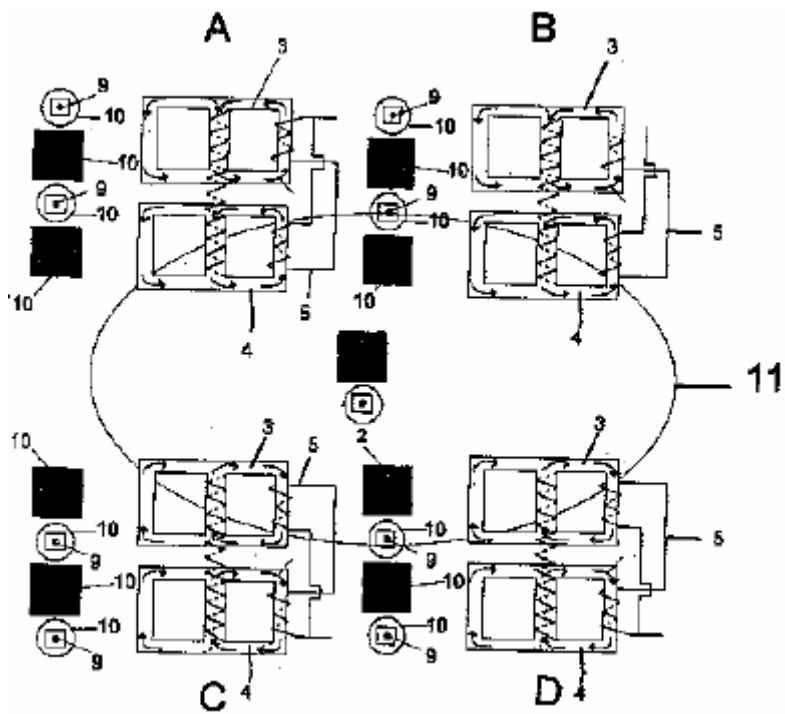

Fig.9 shows the circuit diagram of the device, indicating the effect of electromagnetic field.

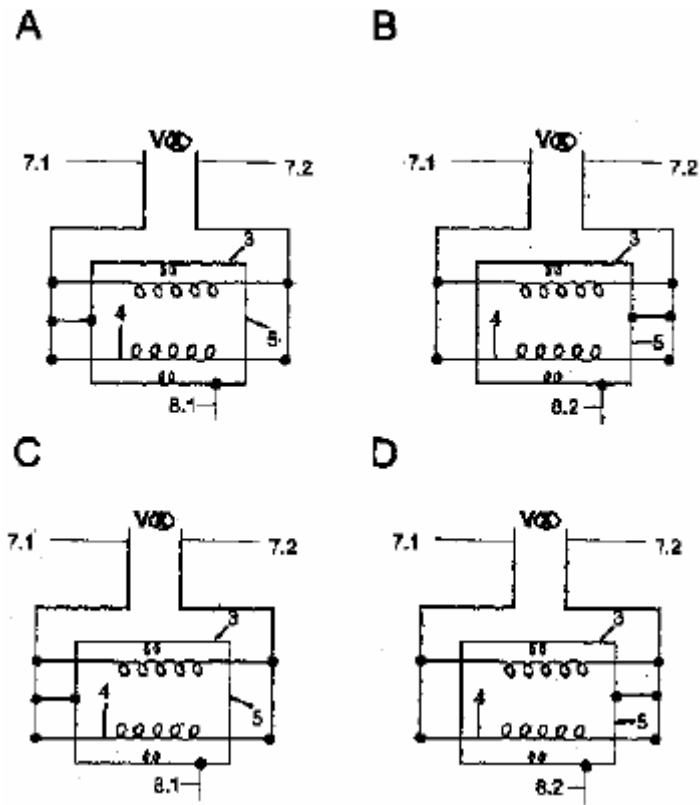

Fig.10 - shows the circuit diagram of the connection of the inductor coils in sets (A, B, C and D).

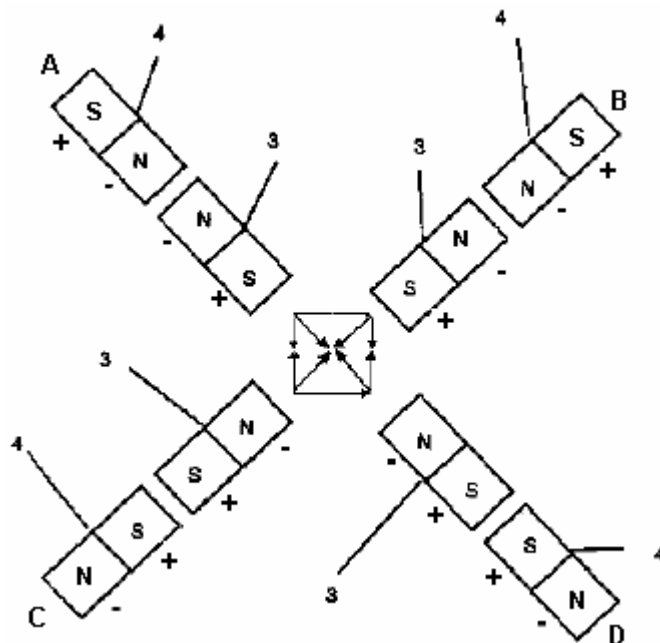

Fig.11 - is an electromagnetic diagram representation of north and south poles of the sets of coils (A, B, C and D).

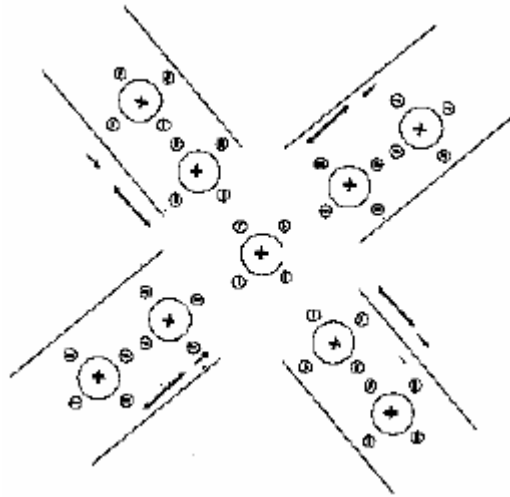

Fig.12 is a representation of the electrons being attracted and repelled by the device.

Detailed Description of the Drawings

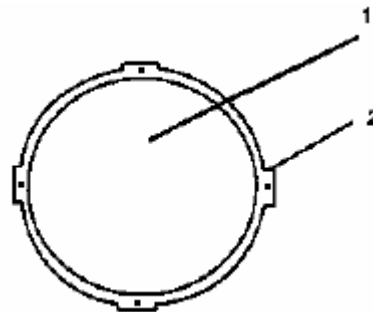

Fig.3

Fig.3 is a top view of one of the two hollow metallic hemispheres 1 which is part of the electron trap of free space proposed in this invention. Hemisphere 1 is preferably made from, but not limited to, aluminium, and it has mounting tabs 2.

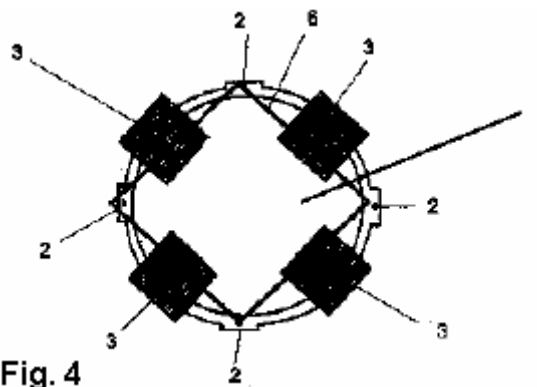

Fig. 4

Fig.4 is a bottom view of metallic hemisphere 1. It has four electromagnetic field generating devices 3, positioned around the hemisphere and fixed to support 6 which is attached to hemisphere 1 by mounting tabs 2.

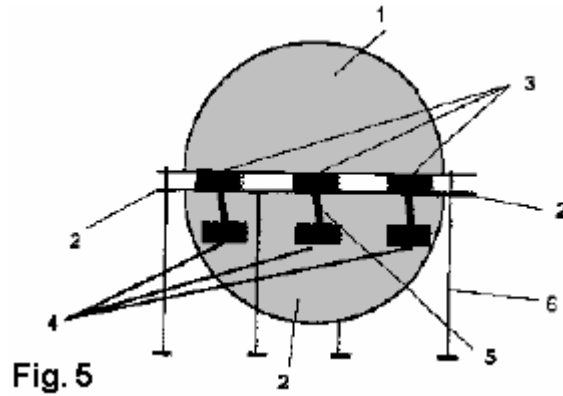

Fig.5 is a side view of the free space electron-trap. It shows the two metallic hemispheres **1** and **2** (which form an imperfect sphere), and three of the coils **3** which are attached to the mounting tabs **2** and three inductors **4** which form the closed circuit itself, and which are attached by conductors **5**, and support member **6** on which are mounted coils **3** and their components.

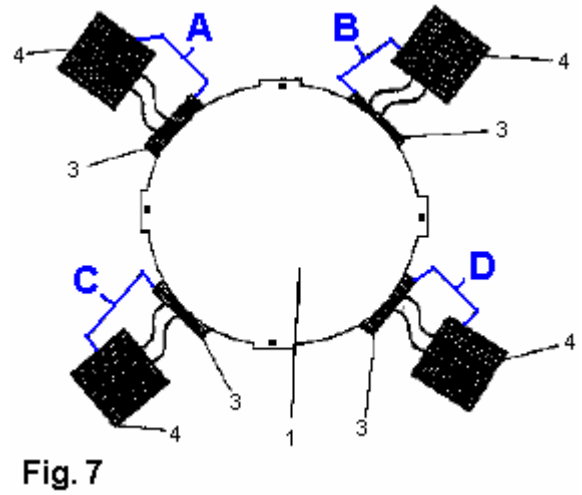
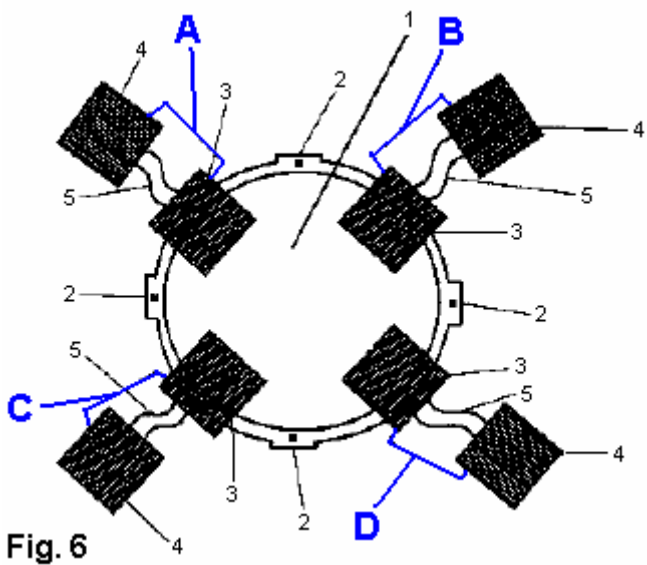

Fig.6 and **Fig.7** show the top and bottom views of the metallic hemisphere **1** which accommodates four coils **3** attached to the holder **6** (not shown) which is secured to the hemisphere **1** by its mounting tabs **2**. **Fig.6** also shows the inductors or electromagnets **4** their corresponding coils **3** and their interconnecting conductors **5**. Each coil **3** and its linked inductor **4** forms a set. In **Figures 6** and **7** there are four such sets, marked **A**, **B**, **C** and **D**. The coils **3**, connected by their links **5**, each have at least one turn, and if the objective is to generate electricity, then preferably two turns, and if the objective is thermal energy, then four turns. The coils **3** may have various different shapes. The number of turns in the coil **3** are directly related to the amount of current to be generated, and the connecting links **5** may be either a single conductor or more than one conductor, the cross-sectional area of conductor **5** being selected to carry the current which is to be generated.

In sets **A**, **B**, **C** and **D**, the link conductors **5** have at least one turn around coils **3**. This winding is connected to the respective electromagnets **4** of each set (**A**, **B**, **C** and **D**) as shown in **Figures 6** and **7**. Please note that the inductors and electromagnets **4** can be any type of inductor, and other types of coil may be used.

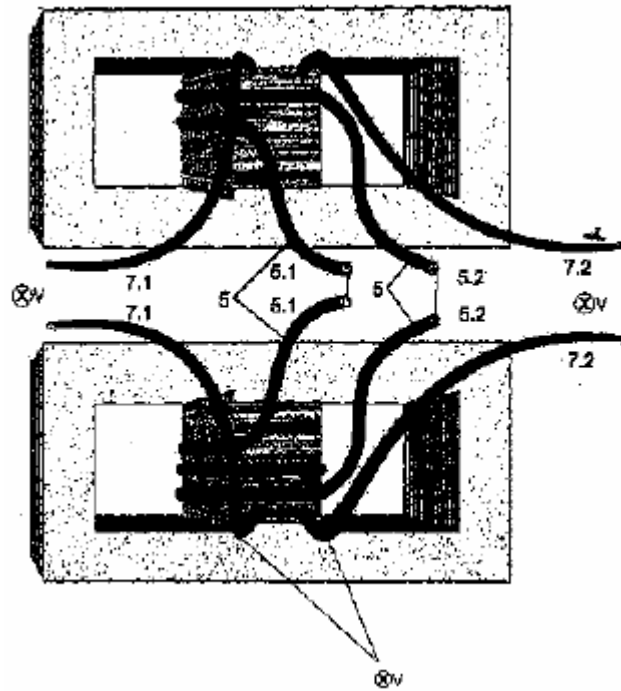

Fig.8 shows the inter-connecting coils **5** for each of the five sets **A, B, C** or **D** linking between coils **3** and **4** in each set. As shown in **Fig.6** and **Fig.7**, the link **5** makes the connection between coils **3** and **4**. This means that the wires marked **5.1** are all connected together, and the wires marked **5.2** are all connected together. Doing this, establishes the interconnection links **5** shown in the drawings. The power supply wires marked **7.1** are connected together as are the wires marked **7.2**. The wires marked **7.1** are connected to the live phase of the external power supply, while the other ends marked **7.2** are connected to the neutral of the external power supply.

In the space free-electron trap of the present invention, the coils **3** can be either single-phase, two-phase or three-phase. Also, the coils **3** may be powered by any voltage (V). The power coil **3** can be energised by any source of electrical energy such as a power grid. The electron-trap can be configured to produce alternating current or direct current. So, if the external power supply is alternating electrical current - AC, then the electron-trap provides an alternating electrical current output. If the power supply is DC, then the electron-trap provides an output of continuous electrical current - DC. The electron-trap can be configured for single-phase, two-phase or three-phase operation, with low, medium or high voltage outputs.

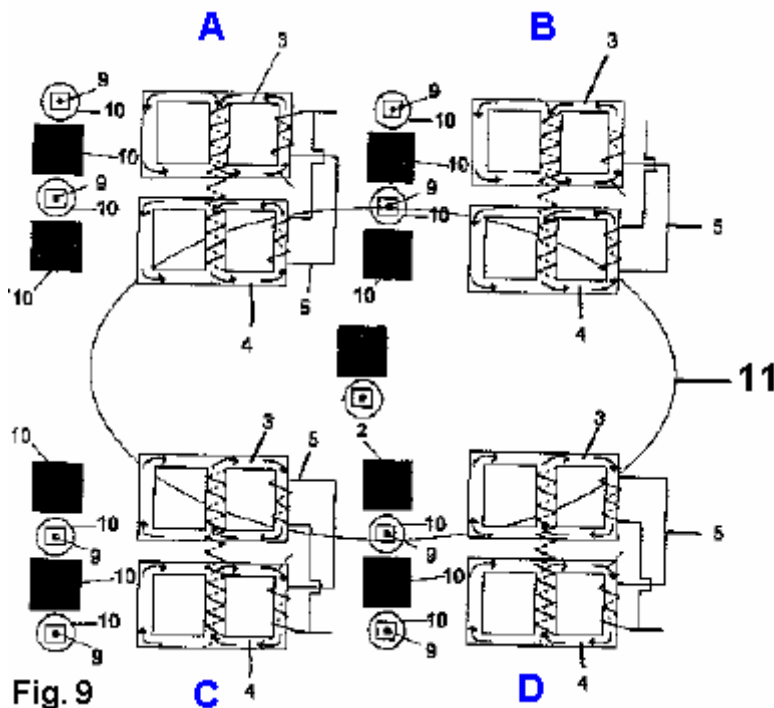

Fig.9 shows an electron-trap circuit diagram with four sets **A, B, C** and **D** of inductor coils **3** and **4**. Induction is produced around core **9** of the three sets of coils **A, B, C** and **D**. The effect of the interaction of the

electromagnetic fields **11** is shown. The induction via core **9**, causes the circulation of electric current in the links **5**, attracting the free electrons through the electromagnetic field of the trap. Then, the electrons join with the current generated by induction on link **5**, circulating between the magnetic poles north-south and south-north.

By way of example, the coils **3** are shown wound on a single phase column type core, but these can also be of any kind or shape. The electron-trap proposed by the present invention can be constructed with another type of electromagnetic field generating device which has at least one electromagnetic coil or magnet or electromagnetic inductor which can be of any kind or shape, or any combination of those, and with any number in each phase of the electron-trap.

The electron capture occurs through an electromagnetic field which is formed with the connection of coils **3** with the electromagnets or inductors **4** through the links **5** between the eight components.

This closure produces the displacement of the electrons in the coil **3** set (**A**) (for simplicity, referred to as coil **3A**), these electrons are attracted by the protons of coil **3D**, and are repelled by the electrons of the electromagnetic field of the coil **3D** itself. These coil **3D** electrons are attracted by the protons of the coil **3B**, and are repelled by the electrons of the electromagnetic field of coil **3B**. These electrons of coil **3B** are attracted by the protons of coil **3C**, and are repelled by the electrons of the electromagnetic field of the coil **3C** itself. Similarly, the **3C** coil electrons are attracted by protons of the **3A** coil, and are repelled by the electrons of the electromagnetic field of the coil **3A** itself. These coil **3A** electrons are attracted by the protons of the **3D** coil, and are repelled by the electrons of the electromagnetic field of the **3D** coil itself. Analogously, the coil **3D** electrons are attracted by the protons of the coil **3B**, and are repelled by the electrons of the electromagnetic field of the coil **3B** itself. These **3B** coil electrons are attracted by the protons of coil **3C**, and are repelled by the electrons of the coil itself induced **3C**, and then the coil **3C** electrons are attracted by protons of coil **3A**, and are repelled by the electrons of the electromagnetic field of the coil **3A** itself. That cycle continues as the sets of coils **A**, **B**, **C** and **D** are being fed by a voltage. These endless attractions and repulsions generate an electric current in the link coil **5**.

In the electron-trap, the voltage is stable. Regardless of the amount of current generated-which can be very high, the voltage will be the same in the electric circuit of the sensor, because the current moves through the attraction and repulsion of the electrons, regardless of voltage.

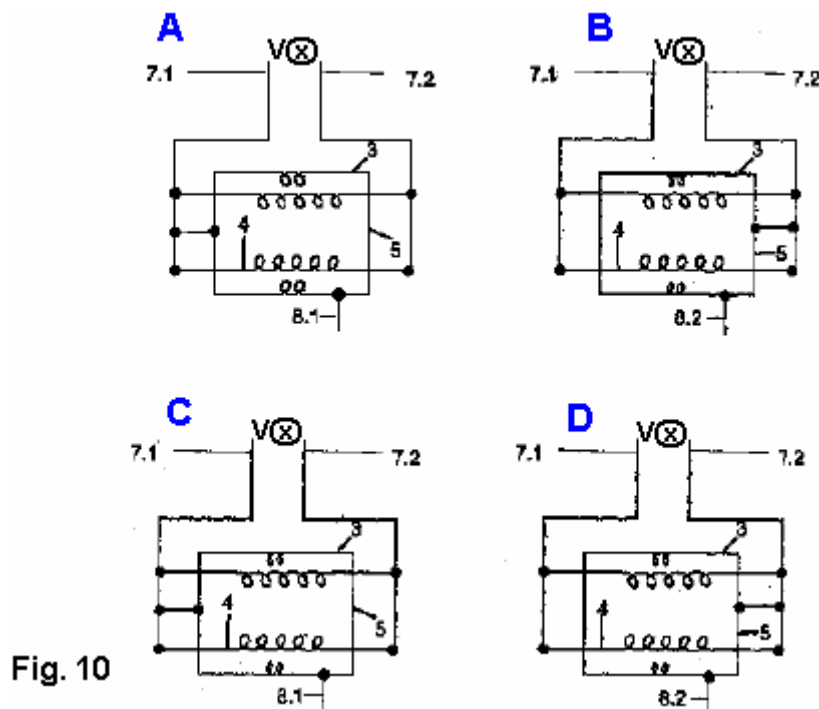

Fig. 10

Fig.10 illustrates a circuit diagram of the electrical connection between the coils **3** and **4** in sets **A**, **B**, **C** and **D**. It can be seen that the sets **A**, **B**, **C** and **D** are enclosed between the coils **3** and their associated inductors or electromagnets **4**. The supply conductors **7.1** and **7.2**, of sets **A**, **B**, **C** and **D** must be interconnected. When feeding power to the coils **3** and **4** the phase should be connected to **7.1** and the neutral to **7.2**.

The sets **A**, **B**, **C** and **D** after being fed with electric current, generate voltage through the attraction and repulsion of the electrons in the linking coil **5**, where there is at least one output load **8.1**, which should be connected joining sets **A** and **C**, and at least one load output **8.2**, which should be connected joining sets **B** and **D**. The output points **8.1** and **8.2** are the respective phases and neutral of power points **7.1** and **7.2**.

In this way, a single-phase electron-trap is created by two pairs of sets of coils/inductors **3** and **4**.

The **3/4** electromagnet coil set can be replaced by a **3/3** coil set, without any disadvantage to the electron-trap.

Sets **A**, **B**, **C** and **D**, are inserted into a hollow metal hemisphere **1** preferably constructed from - but not limited to - aluminium. The hemisphere **1**, whose function is to concentrate and maximise their electromagnetic fields, simulating an electron cloud, has a fixed support **6** connected to attachment tabs **2**, and to which the coils **3** are fixed.

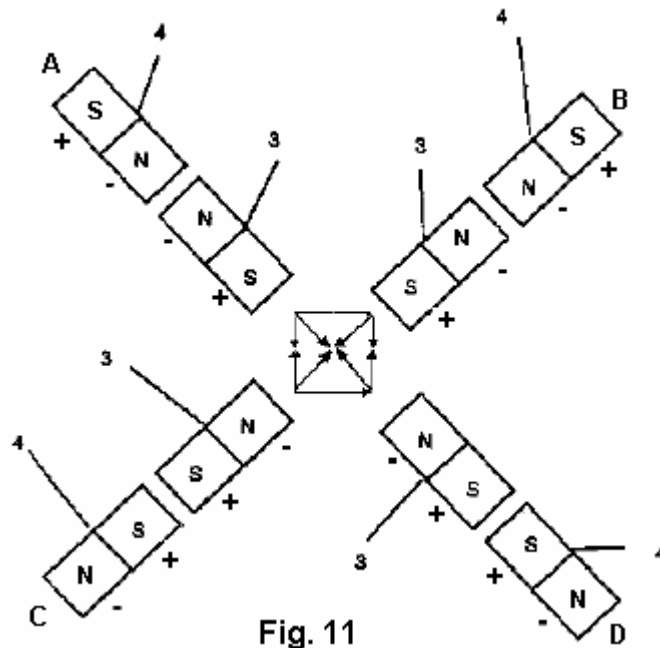

Fig. 11

Fig.11 is a diagram of the electromagnetic north and south poles of the inductor coils **3** and **4** of sets **A**, **B**, **C** and **D** of the electron-trap. The electromagnetic behaviour described for **Fig.9** is again demonstrated by the formation of the magnet assembly to the North Pole and South Pole being attracted and repelled by the lines of force of the magnet from the point "A" to point "D", point "A" to point "B", the point "B" to point "C", point "C" to point "A", and so on, as long as there is an electromagnetic field. The electromagnetic field of the space electron-trap provides that induced current in a direction similar to the variations of the magnetic flux that produced it. So, the magnetic field creates a north pole and a south pole in each of the sets **A**, **B**, **C** and **D**, as shown in **Fig.11**.

By feeding the coils **3** of the electron-trap with a desired voltage a magnetic field is generated in coils **3**, between the four sets **A**, **B**, **C** and **D**, which form a flow of electrons. This flow of electrons augments the electron flow which is circulating in the closed-loop link-coil **5**, thus implementing free electron capture from space. The electromagnetic field of the coil **3A** runs north to south, the electromagnetic field of the coil **3B** runs north to south, the electromagnetic field of the coil **3C** flows from south to north, and the electromagnetic field of the coil **3D** flows from south to north, as shown in **Fig.11**. It should be noted that the sets **A**, **B**, **C** and **D** can be formed by any combination of coil, magnet and electromagnet.

The south to north electromagnetic field induces current flow in the coil **3A**. The north to south electromagnetic field induces current flow in the coil **3B**. The north to south electromagnetic field induces current flow in the coil **3C** and The north to south electromagnetic field induces current flow in the coil **3D**. The induced current flow can have any power and it can be single-phase, two-phase or three-phase current.

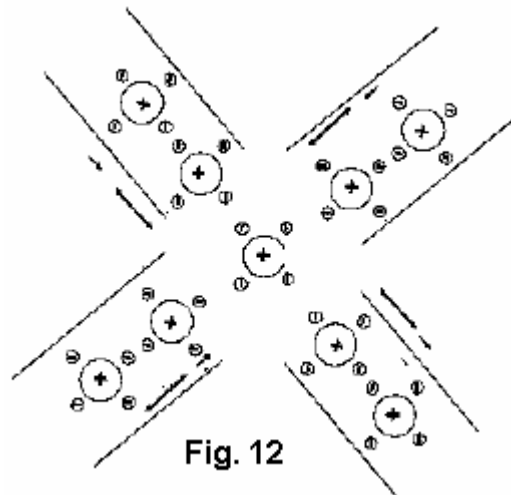

Fig. 12

Fig.12 shows the electrons being attracted and repelled by the induction coils **3** and **4**. Being repelled and attracted by electromagnetic induction, the electric current flows without resistance.

The electron-trap produces electromagnetic waves which can be used for various purposes, including signal transmission at any frequency and for any purpose. The capture is caused by these electromagnetic waves. The same physical effect can be achieved by the combination of the capture devices of other technologies, including electromechanical, electric, electronic, electromagnetic, or through the combination of a magnet or any other magnetised materials.

The space free electron-trap of the present invention is a renewable source of electrical power production and a new way of generating energy through the capture effect, generating flows of electrons, generating ordered movement of electrons - electric current - as shown in **Figures 9, 11, and 12**. Electrons can move without any voltage difference in the continuous loop **5**. Alternatively, the loop may be biased with any chosen voltage.

The relevant Barbosa and Leal patents in Portuguese can be downloaded here:

<http://www.free-energy-info.tuks.nl/Barbosa1.pdf>

<http://www.free-energy-info.tuks.nl/Barbosa2.pdf>

<http://www.free-energy-info.tuks.nl/Barbosa3.pdf>

Scientific Papers

The following links connect to various scientific papers and documents of interest. As web-based resources are very prone to change and disappear, if you download any of these to read, I suggest that you store them on your local drive in case they become unavailable at a later date. If, for any reason, the www.free-energy-info.co.uk web site is not available, then you can try www.free-energy-info.com or www.free-energy-devices.com which are mirror sites.

- <http://www.free-energy-info.tuks.nl/P1.pdf> 4 Mb Pulsed DC electrolysis
- <http://www.free-energy-info.tuks.nl/P2.pdf> 360 Kb Water arc explosions
- <http://www.free-energy-info.tuks.nl/P3.pdf> 388 Kb Plasma electrolysis
- <http://www.free-energy-info.tuks.nl/P4.pdf> 321 Kb Cold water fog explosions
- <http://www.free-energy-info.tuks.nl/P5.pdf> 151 Kb Engine operation with hydrogen added to the fuel
- <http://www.free-energy-info.tuks.nl/P6.pdf> 63 Kb Bubbles and steam electricity
- <http://www.free-energy-info.tuks.nl/P7.pdf> 600 Kb Stan Meyer's Water Fuel Cell
- <http://www.free-energy-info.tuks.nl/P8.pdf> 3.5 Mb Stan Meyer's Water Fuel Cell
- <http://www.free-energy-info.tuks.nl/P9.pdf> 303 Kb Water as Fuel by Stan Meyer
- <http://www.free-energy-info.tuks.nl/P10.pdf> 68 Kb Solar Hydrogen Production
- <http://www.free-energy-info.tuks.nl/P11.pdf> 328 Kb Passive Cooling
- <http://www.free-energy-info.tuks.nl/P13.pdf> 347 Kb A Solar Ice-maker
- <http://www.free-energy-info.tuks.nl/P14.pdf> 711 Kb Smart-Skin Shielding Technology
- <http://www.free-energy-info.tuks.nl/P15.pdf> 215 Kb Physics for Engineers
- <http://www.free-energy-info.tuks.nl/P16.pdf> 2.5 Mb Fuel Cell Handbook
- <http://www.free-energy-info.tuks.nl/P17.pdf> 62 Kb Prof. Kanarev's Low-current Electrolysis
- <http://www.free-energy-info.tuks.nl/P18.pdf> 8 Mb Principles of Ultra Relativity by Shinichi Seike
or <http://www.megaupload.com/?d=ZPKEL2DX>
- <http://www.free-energy-info.tuks.nl/P21.pdf> 754 Kb The Theory of Anti-gravity
- <http://www.free-energy-info.tuks.nl/P22.pdf> 13.3 Mb Physics Without Einstein by Dr Harold Aspden
or <http://www.megaupload.com/?d=K92I58T0>
- <http://www.free-energy-info.tuks.nl/P23.pdf> 6.9 Mb Modern Aether Science by Dr Harold Aspden

or <http://www.megaupload.com/?d=SPMZO1LT>

<http://www.free-energy-info.tuks.nl/P24.pdf> 10 Mb Unified Physics by Dr Harold Aspden

or <http://www.megaupload.com/?d=IQ45U6NG>

<http://www.free-energy-info.tuks.nl/P25.pdf> 1.5 Mb Permanent Magnet Motor Design

<http://www.free-energy-info.tuks.nl/P26.pdf> 402 Kb The Sea of Energy by Thomas Henry Moray

<http://www.free-energy-info.tuks.nl/P31.pdf> 14.5 Mb Tesla's Science of Energy by Dr Thomas Valone

or <http://www.megaupload.com/?d=SS0S3GH9>

<http://www.free-energy-info.tuks.nl/P32.pdf> 605 Kb High Voltage, High Frequency Alternating Currents
by Nikola Tesla

<http://www.free-energy-info.tuks.nl/P33.pdf> 632 Kb "Prodigal Genius" biography of Nikola Tesla

<http://www.free-energy-info.tuks.nl/P34.pdf> 488 Kb Damped Waves by Nikola Tesla

<http://www.free-energy-info.tuks.nl/P41.pdf> 3.2 Mb Electrogravitics Systems by Dr Thomas Valone

<http://www.free-energy-info.tuks.nl/P42.pdf> 2.5 Mb Zero-Point Energy Extraction by Dr Thomas Valone

<http://www.free-energy-info.tuks.nl/P63.pdf> 181 Kb Scalar Waves by Konstantin Meyl

<http://www.free-energy-info.tuks.nl/P65.pdf> 592 Kb EsotericScience.com Presentation

<http://www.free-energy-info.tuks.nl/P66.pdf> 450 Kb The Genesis Project

<http://www.free-energy-info.tuks.nl/Lodge.pdf> 27 Mb. Modern Views of Electricity by Sir Oliver Lodge

<http://www.free-energy-info.tuks.nl/Lodge2.pdf> 9 Mb. The Ether of Space by Sir Oliver Lodge

<http://www.free-energy-info.tuks.nl/Lodge3.pdf> 22 Mb. The Nature and Properties of Negative Electricity
by Sir Oliver Lodge

<http://www.free-energy-info.tuks.nl/TeslaBook.pdf> 36 Mb. The Inventions, Researches and Writings of Nikola
Tesla by Thomas Commerford Martin

<http://www.free-energy-info.tuks.nl/DonKelly.pdf> 13 Mb. The 'Manual of Free Energy Devices and Systems'
by Donald A. Kelly

<http://www.free-energy-info.tuks.nl/Blitz.pdf> 30 Mb. Ultrasonics by Jack Blitz

<http://www.free-energy-info.tuks.nl/Magnetos.pdf> 9.5 Mb. Magnetos Simply Explained by F. H. Hutton

<http://www.free-energy-info.tuks.nl/TeslaPatents/TeslaPatents.pdf> 100 Mb. All of Tesla's published patents

http://www.free-energy-info.tuks.nl/Magnetic_Motor.pdf 511 Kb Magnetic Motors by Lawrence Tseung

<http://www.free-energy-info.tuks.nl/Maxwell.pdf> 2.2 Mb The Electromagnetic Field by James Clerk Maxwell

<http://www.free-energy-info.tuks.nl/Davson.pdf> 46.7 Mb Davson's book on Karl Schappeller's work
or <http://www.megaupload.com/?d=IRBTBAO0>

<http://www.free-energy-info.tuks.nl/Newman.pdf> 97 Mb The Energy Machine of Joseph Newman
or <http://www.megaupload.com/?d=5MF8ZFAJ>

<http://www.free-energy-info.tuks.nl/Combine.pdf> 2.1 Mb Radiant Energy and Over-Unity by Dan Combine

<http://www.free-energy-info.tuks.nl/Rodin.pdf> 3 Mb The Rodin Solution Project by Marko Rodin

<http://www.free-energy-info.tuks.nl/SEG.pdf> 594 Kb Magnetic Gravity Research by Roschin and Godin

http://www.free-energy-info.tuks.nl/Stan_Meyer_Full_Data.pdf 3.8 Mb Technical Brief by Stan Meyer

<http://www.free-energy-info.tuks.nl/LTseung.pdf> 3.2 Mb Over-unity Devices by Lawrence Tseung

<http://www.free-energy-info.tuks.nl/Smith.pdf> 2.0 Mb. Resonant Energy Methods by Donald Lee Smith

<http://www.free-energy-info.tuks.nl/Cottrell.pdf> 2.8 Mb. How Gravity Works by Maurice Cottrell

<http://www.free-energy-info.tuks.nl/Davidson.pdf> 4.5 Mb. Shape Power by Dan Davidson

Videos

<http://www.free-energy-info.tuks.nl/Meyer.wmv> 4.6 Mb or <http://www.megaupload.com/?d=977Z6MJA>

<http://www.free-energy-info.tuks.nl/Newman.avi> 53 Mb

<http://www.free-energy-info.tuks.nl/pyramid.avi> 25 Mb

<http://www.free-energy-info.tuks.nl/stage1.wmv> 1.9 Mb

<http://www.free-energy-info.tuks.nl/stage2.wmv> 1.9 Mb

<http://www.free-energy-info.tuks.nl/stage3.wmv> 3.7 Mb

<http://www.free-energy-info.tuks.nl/WFCrep2.wmv> 1 Mb

<http://www.free-energy-info.tuks.nl/stan.wmv> 4.5 Mb or <http://www.megaupload.com/?d=977Z6MJA>

<http://www.free-energy-info.tuks.nl/WFCrep.wmv> 5.3 Mb or <http://www.megaupload.com/?d=38G9MH11>

<http://www.free-energy-info.tuks.nl/Bills.avi> 17 Mb or <http://www.megaupload.com/?d=KIQ793LU>

<http://video.google.com.au/videoplay?docid=-7365305906535911834>

<http://video.google.com.au/videoplay?docid=2650242262168838984&q=free+energy&total=5428&start=0&num=100&so=1&type=search&plindex=1>

<http://video.google.co.uk/videoplay?docid=3091681211753181299&q=Newman+car&total=119&start=0&num=10&so=0&type=search&plindex=1>

<http://video.google.com/videoplay?docid=-635987818295327978>

<http://video.google.com/videoplay?docid=-4298347669641896403>

<http://video.google.com/videoplay?docid=-8435800732540412467&hl=en>

<http://video.google.com/videoplay?docid=333661567309752927&hl=en>

<http://video.google.com/videoplay?docid=-5483558279656482347&hl=en>

<http://www.youtube.com/watch?v=-6MDHF39XmU&NR>

<http://video.google.com/videoplay?docid=-6461713170757457294>

<http://video.google.com/videoplay?docid=-721789270445596549>

<http://video.google.com/videoplay?docid=-2850891179207690407>

<http://video.google.com/videoplay?docid=-8635897559220353909>

<http://video.google.com/videoplay?docid=2229511748333360205>