

Popular Electronics®

PLUS!
Exploring
Robotics
Online

A DTMF Computer Interface

Use this project to capture and decode phone numbers from the airwaves and display them on your PC

High-Voltage Power

It has few parts, but this circuit creates plenty of kilovolts

Wireless Control

Build this transmitter/receiver pair and control almost any electronic device

Gizmo®

Robo-LEGO, MiniDisc Recording Deck, Wireless Net Access in your Pocket? Software, Radio with Bass, and more

Also Inside:

- Digital Camcorder and Camera Reviews
- Affordable Flat-Panel Monitors
- Hall Effect Sensor Circuits
- Scanner Antenna Tips



\$4.99 U.S.
\$5.99 CAN.



A GERNSBACK PUBLICATION

SUPER-SIMPLE HIGH-VOLTAGE CIRCUIT

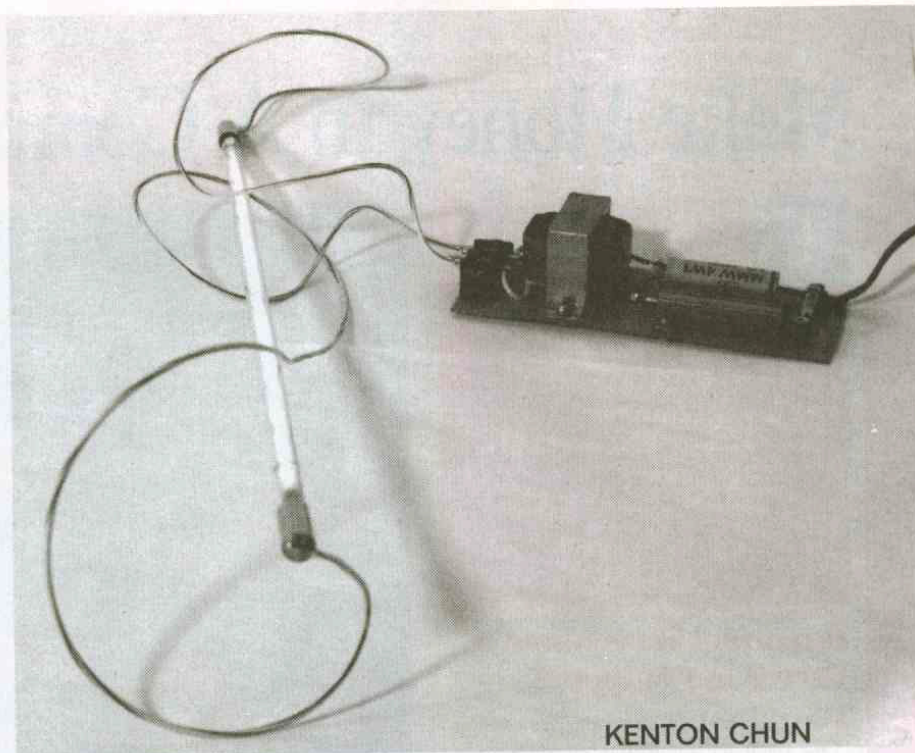

KENTON CHUN

If you're a dedicated electronics hobbyist, you have probably needed a high-voltage power source at some time or another. Maybe you wanted to energize a neon tube or an old plasma-discharge laser. Or perhaps you were building an electric fence or trying to trigger a xenon strobe tube. No matter what you were trying to accomplish, you probably ran into the same problem every time—how to efficiently and economically generate a high voltage.

High-voltage technology has not changed much in the last century. Usually, we don't electrostatically generate high voltages, except for experimental or educational purposes, or by accident when we pet the cat. In most cases, we want to produce high voltages from relatively low DC voltages or ordinary 117-volt house current. In the case of a DC power supply, the typical solution is to create a DC-to-AC power inverter, and then step up the resulting AC through a transformer. That's often a very inefficient process.

Generating a high voltage from an AC power source is often even worse. In that case, alternating current must be stepped down to some low voltage, rectified (to provide DC), and then put through a

Thanks to the development of the SIDAC, it is now easy to generate a high-voltage output capable of driving neon or laser tubes without resorting to the inefficient and complicated circuit configurations of the past.

DC to AC circuit. Talk about inefficient. Each conversion (or inversion) decreases efficiency.

The simplest way to generate a high voltage is to use AC voltage as the initial power source, which can be stepped up via transformer. The latter method is reliable and efficient, but requires enormous transformers (which strictly follow the power factor rules) for even modest voltage gains. Generally speaking, doubling the secondary output voltage requires twice the primary current. A typical neon transformer can supply 10–12 kV at 30 mA and draw almost 400 watts! The killer is that the transformer is likely to weigh about twenty pounds.

Basic DC-to-AC Inverters. Figure 1

illustrates the most basic form of DC-to-AC inverter. When momentary switch S1 is in its normally open position, no current flows in the circuit. Closing S1 causes current to flow from the battery into the primary winding of T1, generating a magnetic field. After a short time, the current reaches its maximum level and S1 is released. The magnetic field in T1 collapses, producing an extremely high-voltage pulse across T1's secondary winding.

While the circuit in Fig. 1 is fairly reliable, it requires a very large current source and a heavy-duty transformer when operated at lower frequencies. Large current demands result in high power factors and high losses. Its greatest drawback is that it requires a warm body to stand around and continually press the button. That type of circuit is also not very energy efficient.

By raising the operating frequency of the circuit, it is possible to use transformers with less iron for the same voltage increase. The reason that WWII avionics ran at 400 Hz was for exactly that reason—you could get away with much lighter transformers. Less weight in an airplane is always better.

Semiconductor-Based Inverter Design. The introduction of mod-

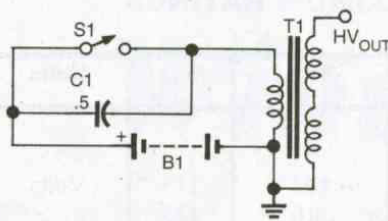

Fig. 1. Shown here is the most basic form of DC-to-AC inverter. While the circuit is fairly reliable, it requires a very large current source and a heavy-duty transformer when operated at lower frequencies.

ern semiconductors has made it possible to assemble a DC-to-AC inverter that operates very efficiently. The circuit in Fig. 2 is an example of a basic high-frequency DC-to-AC inverter. Many of the high-efficiency 12-volt DC to 117-volt AC power inverters and uninterruptible power supply (UPS) designs use a similar configuration as the heart of the circuit.

In the Fig. 2 circuit, an NE555 oscillator/timer (IC1) is set up as a pulse generator, the frequency of which can be set to almost any value. The output of IC1 is directed through a transformer and stepped up to the required level. The major limitation of the Fig. 2 circuit is its output power. The NE555 can directly source up to 200 mW through the transformer, but at the power-supply rail of 9 volts, that's barely enough power to light a tiny neon lamp. Only by adding output switches and a higher supply current can the circuit provide enough power to start a laser or a neon tube.

An SCR-Based Inverter. Another solution to the power problem is to use a high-current switch, such as an SCR to drive the primary winding of a large step-up transformer, as shown in Fig. 3. In the Fig. 3 circuit, the power comes from the utility, while the circuit's DC operating voltage is derived from a diode rectifier (comprised of D1 and D2) and a series capacitor (C1). Another capacitor (C2) charges to about 125 volts and supplies current through the Zener-diode regulator and potentiometer to the gate of a unijunction transistor (UJT), Q1. When Q1 discharges, a trigger voltage is applied to the gate of SCR1, causing it to turn on.

With SCR1 turned on, capacitor C3 dumps its charge across the primary of T1, generating a high-voltage pulse in T1's secondary winding. The main drawback to the Fig. 3 circuit is the high parts count and complexity. So what's the alternative?

Another Way. In the world of high-voltage power applications, the tradeoff appears to be efficiency at the cost of size and/or complexity. Wouldn't it be nice to find a single semiconductor component capable of replacing the handful of resistors, capacitors, unijunction transistors, and SCRs, while having the capacity to efficiently switch several amps of power? Well, such a component—dubbed the SIDAC—already exists.

The SIDAC—which can be defined as a silicon, bilateral, voltage-triggered switch—has a high

SIDAC immediately goes into conduction in the same regenerative manner as a Triac or SCR: as the voltage across the device drops to a typical "on" value of a couple of volts or so. Because the SIDAC is bilateral, it behaves in the same manner regardless of voltage polarity. That makes it ideally suited to power switching in AC circuits.

SIDACs come in several styles. Motorola's MKP series is rated at 4 amps, while the MK series is rated at a whopping 20 amps. Typical SIDAC specifications are given in Table 1. The device's breakover voltage is indicated by the three-digit number at the end of the device code. Devices are available with breakover voltages of 120, 130, and 240-270 volts. Best of all, in quantities of less than 100, they are cheap—typically selling for about half a buck.

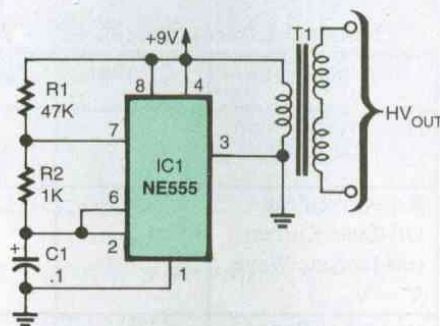

Fig. 2. At the heart of this DC-to-AC inverter is an NE555 oscillator/timer (IC1) set up as a pulse generator. Many high-efficiency 12-volt DC to 117-volt AC power inverters and uninterruptible power supply (UPS) designs use similar configurations.

SIDAC-Based HV Circuit. Figure 4 shows a very efficient, but simple high-voltage circuit comprised of only five components, including the transformer and a fuse. For continuous duty, a thermal protector—a thermal link that opens up the circuit if it reaches 300-400°F—should be connected in series with resistor R1, giving the circuit a total parts count of six components.

The combination of R1 and C1 yields a time constant of about 2 milliseconds, which charges C1 to 117 volts at about the 90-degree point in the sinusoidal input-voltage waveform. It is at about that point that the SIDAC conducts and continues to do so for the duration of the first half cycle. The SIDAC then dissipates power as the input volt-

"off" impedance at any voltage below its breakover voltage. When the voltage across the device reaches the breakover point, the

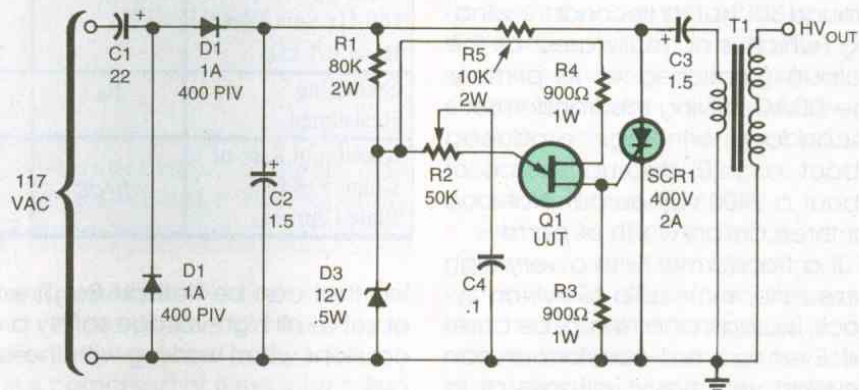

Fig. 3. This high-voltage circuit uses an SCR to drive the primary winding of a large step-up transformer. The main drawback of this circuit is its high parts count and complexity.

age declines toward the zero-crossing point. When the line voltage goes through zero crossing, the SIDAC turns off, waiting as C1 begins to charge to the opposite breakover-voltage point. When the opposite breakover point is reached, the SIDAC once again turns on.

During each half cycle, the circuit produces a high-voltage pulse at the output of transformer T1. That's a very efficient design from a transformer standpoint, since you are putting AC across its primary as opposed to the DC voltage used in the earlier circuits. The bottom line is that you can get away with less hardware, and transformer selection is not as critical as it is with other designs. Just about any transformer will work.

The author used a common 6-volt step-down AC power trans-

PARTS LIST FOR THE SUPER-SIMPLE HIGH-VOLTAGE CIRCUIT

- D1—MK1V115—MK1V135 SIDAC bilateral trigger (see text)
 - R1—2000-ohm, 10-watt, power resistor
 - C1—1- μ F, 200-WVDC, Mylar capacitor
 - F1—0.5-amp fuse
 - PL1—117-volt AC line cord with molded plug
 - T1—Step-up transformer (see text)
 - TH1—Thermal protector—optional (see text)
 - Perfboard material, 2-position barrier block, wire, solder, hardware, etc.
- Note:** Additional information about the SIDAC is available from Motorola's Web site at <http://sps.motorola.com>.

former; the transformer was turned around so that its secondary winding (which is normally used as the output) functioned as its primary. The SIDAC, driving the transformer's secondary winding, produced about a 1:20 step-up factor, or about a 2400-volt output. Not bad for three dollars worth of parts!

If a transformer with a very high turns ratio, such as a television flyback, is used in that setup, be careful! Even a small transformer can develop very nasty voltages at its output; at the power levels that the Fig. 4 circuit is capable of develop-

TABLE 1—SIDAC MAXIMUM RATINGS

Rating	Symbol	Min	Max	Units
Repetitive Breakover Voltage				
MK1V-115	$V_{(BO)}$	104	115	Volts
MK1V-125		110	125	
MK1V-135		120	135	
Off-State Repetitive Voltage	V_{DRM}	—	± 90	Volts
On-State Current RMS (All Conduction Angles)	$I_{T(RMS)}$	—	1.0	Amps
On-State Surge Current (Non-Repetitive) (60-Hz One Cycle Sine Wave Peak Value)	I_{TSM}	—	20	Amps
Operating Junction Temperature	T_J	-40	+125	$^{\circ}$ C
Storage Temperature Range	T_{stg}	-40	+150	$^{\circ}$ C
Lead Solder Temperature	T_L	—	+230	$^{\circ}$ C

Electrical Characteristics ($T_J = 25^{\circ}$ C unless otherwise noted)

Characteristic	Symbol	Min	Typ	Max	Unit
Breakover Current (60-Hz Sine Wave)	$I_{(BO)}$	—	—	200	μ A
Repetitive Peak Off-State Current (60-Hz Sine Wave, $V = V_{DRM}$)	I_{DRM}	—	—	10	μ A
Repetitive Peak On-State Current ($T_C = 25^{\circ}$ C, Pulse Width = 10 μ S, Repetition Frequency, $f = 1.0$ kHz)	I_{TRM}	—	20	—	Amps
Forward "On" Voltage ($I_{TM} = 1.0$ A peak)	V_{TM}	—	1.1	1.5	Volts
Dynamic Holding Current (60-Hz Sine Wave, $R_S = 0.1$ k Ω)	I_H	—	—	100	mA
Switching Resistance	R_S	0.1	—	—	k Ω
Maximum Rate of Change of On-State Current	di/dt	—	50	—	A/ μ S

ing that can be "lethal." Be sure to observe all high-voltage safety precautions when working with the circuit.

Important Note: Using an isolation transformer between the AC

power source and the circuit would make the circuit a bit safer to operate.

In the event that the SIDAC fails, which would be the worst case (Continued on page 66)

DTMF INTERFACE

(continued from page 34)

0-9, *, # several times, and then hang up the phone.

Once the answering machine resets, simply remove the tape and play it back using a cassette recorder with an earphone jack. After cueing up the tape to the portion containing the DTMF tones, connect the interface to the recorder's earphone jack, and play back your test tape. DTMF digits should now begin appearing on your monitor. If no digits appear, try raising or lowering the tape recorder's (or scanner's) volume-control setting and try again. However, normal volume should suffice.

If incorrect digits appear on the monitor (for example, the digit received was known to be a DTMF "1," but a "4" was displayed), then re-check the wiring of the DB-25 connector and try again. After everything is working properly, install the cover onto the enclosure, and show your friends that useful monitoring accessories don't have to be expensive. ■

HIGH-VOLTAGE CIRCUIT

(continued from page 40)

condition, R1 would take the full 117-volt line, dissipating approximately 7.2 watts. At the maximum line-voltage tolerance of 117 volts AC + 10%, or about 129 volts AC, the resistor would have to dissipate about 8.3 watts. If a 10- or 20-watt resistor were used, you'll probably never have a problem. But if you are concerned, the optional thermal cut-out protector mentioned earlier can be attached to R1 to provide added protection for the circuit in the event of a catastrophic failure.

Construction. The author's prototype unit was assembled on a small section of perforated construction board measuring approximately 6 by 2⁷/₁₆ inches (which is about the width the transformer's base). Assemble the circuit, using Fig. 4 (the circuit's schematic diagram) as a guide. Start by temporarily

mounting the components to the perfboard section. When mounting power resistor R1, be sure that it is mounted away from anything flammable and that sufficient space is provided between the power resistor and any other components to allow good air flow around the resistor. **Note:** Although the author specifies a 10-watt power resistor in the Parts List, the unit used in the prototype is a 50-watt, metal-enclosed unit. Using a resistor of sufficient power-handling capacity helps to guard against possible mishap.

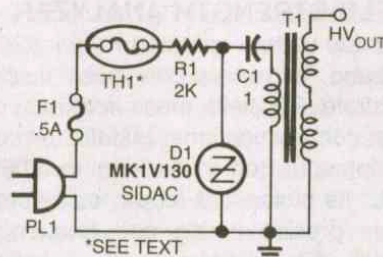

Fig. 4. This circuit featuring a SIDAC (which can be defined as a silicon, bilateral, voltage-triggered switch) reduces the cost and complexity of assembling high-voltage circuits, while retaining the capacity to efficiently switch several amps of power.

Depending on the line voltage in your area and the SIDAC you use, it may be necessary to adjust the value of R1 in order to get the circuit to switch at or before 90 degrees. Doing so reduces the amount of power R1 is required to dissipate, while allowing sufficient margin to enable the SIDAC to fire slightly after 90 degrees in the event that the line voltage goes low.

A two-position barrier block was tied to the transformer output and used to connect the circuit's high-voltage source to an 18-inch long, small-diameter neon tube.

Use. With its 2400-volt output, the circuit can be used to fire neon tubes. The author used the circuit to repair an ancient "weed-burner" fence charger by replacing the burned-out mechanical vibrator with this SIDAC-based circuit. With high-voltage rectification, the circuit can be used as a plasma neon laser supply or an air ionizer. Use your imagination—the possibilities are limitless! ■

SCANNER SCENE

(continued from page 12)

between them. Split your 16 oz. can of Pepsi with a pal and what's left for you? Just enough to fill an 8 oz. glass! Split the antenna's received energy, and it's divided in half to each scanner. Not to worry. Although each set will notice a minimal 3-dB signal loss, in most instances this should be imperceptible to you. Weak signals can be rejuvenated with a SuperAmplifier.

MONITORING THE FEDS

Barry, of Charleston, SC, reports monitoring unidentified communications on 140.075 MHz, and he asks for more information. We looked it up, and it's the Channel 1 repeater of the U.S. Naval Investigative Service! This agency uses the same eight channels, nationwide.

Interest in monitoring federal agencies continues to tantalize scanner owners. An excellent guide for Barry and everyone else who's interested is the huge 308-page *Federal Government Frequency Assignments, 6th Edition*. Here's the all-in-one resource for the latest known VHF/UHF frequencies used by the U.S. military services; the Secret Service, ATF, CIA, DEA, FBI, Border Patrol, and Immigration; IRS, Customs Service, and Postal Inspectors; EPA, FAA, FCC, NASA, and NSA; and by the National Park Service, Dept. of Agriculture, and so on. CTCSS tone information is provided.

Plenty of additional information reveals military satellite communications channels, White House code names, USAF aircraft IDs, etc. Frequencies are listed by agencies, and they are also cross-indexed. Special lists show all (1500+) assignable federal frequencies from 29-420 MHz.

This great reference is \$24.95, plus \$5 shipping/handling (\$7 to Canada) from CRB Research Books, Inc., P.O. Box 56, Commack, NY 11725; Tel. 516-543-9169; Web (fully secure site): www.crbbooks.com. Residents of NY state, please include \$2.47 tax. MC/VISA are OK.

We invite your questions, comments, and frequencies. Our direct e-mail address is Sigintt@juno.com. Send snail mail to *Scanner Scene*, Popular Electronics, 500 Bi-County Blvd., Farmingdale, NY 11735. ■